

General Disclaimer

One or more of the Following Statements may affect this Document

- This document has been reproduced from the best copy furnished by the organizational source. It is being released in the interest of making available as much information as possible.
- This document may contain data, which exceeds the sheet parameters. It was furnished in this condition by the organizational source and is the best copy available.
- This document may contain tone-on-tone or color graphs, charts and/or pictures, which have been reproduced in black and white.
- This document is paginated as submitted by the original source.
- Portions of this document are not fully legible due to the historical nature of some of the material. However, it is the best reproduction available from the original submission.

JSC-10683
REV. A

ATMOSPHERIC SCIENCE FACILITY

PALLET-ONLY MODE

SPACE TRANSPORTATION SYSTEM PAYLOAD

(FEASIBILITY STUDY)

INTERIM TECHNICAL REPORT

VOLUME 2

BY

EXPERIMENT SYSTEMS DIVISION

(NASA-TM-X-72957) ATMOSPHERIC SCIENCE
FACILITY PALLET-ONLY MODE SPACE
TRANSPORTATION SYSTEM PAYLOAD (FEASIBILITY
STUDY), VOLUME 2 Interim Technical Report
(NASA) 150 p HC \$6.00

N76-18202

Unclas
CSCI 22E G3/16 18415

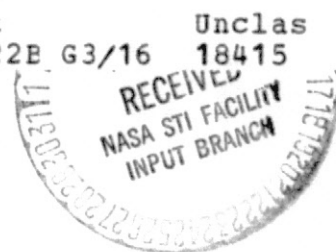

National Aeronautics and Space Administration
LYNDON B. JOHNSON SPACE CENTER

Houston, Texas
November 1975

APPENDIX A
ASF EXPERIMENT DESCRIPTIONS

CONTENTS

| Section | Page |
|--|------|
| 1.0 WIND, TEMPERATURE AND DIFFUSION EXPERIMENTS. | A-1 |
| 1.1 <u>IDENTIFY PROPERTIES OF NATURAL TRACERS</u> <u>(EXPERIMENT AS-1)</u> | A-1 |
| 1.1.1 SCIENTIFIC OBJECTIVES. | A-1 |
| 1.1.2 METHODS. | A-1 |
| 1.1.3 INSTRUMENTS REQUIRED | A-2 |
| 1.1.4 ORBIT AND TIMELINE CONSTRAINTS | A-3 |
| 1.2 <u>MEASURE WINDS AND TEMPERATURE FIELDS</u> <u>(EXPERIMENT AS-2)</u> | A-3 |
| 1.2.1 SCIENTIFIC OBJECTIVES. | A-3 |
| 1.2.2 METHODS. | A-3 |
| 1.2.3 INSTRUMENTS REQUIRED | A-4 |
| 1.2.4 ORBIT AND TIMELINE CONSTRAINTS | A-4 |
| 1.3 <u>PROFILE THE ATMOSPHERE TEMPERATURE IN THE</u> <u>REGION OF 15 km to 120 km ALTITUDE</u> <u>(EXPERIMENT AS-3)</u> | A-4 |
| 1.3.1 SCIENTIFIC OBJECTIVES. | A-4 |
| 1.3.2 METHODS. | A-4 |
| 1.3.3 INSTRUMENTS REQUIRED | A-5 |
| 1.3.4 ORBIT AND TIMELINE CONSTRAINTS | A-5 |
| 1.4 <u>DETERMINE THE THERMAL STRUCTURE AND DYNAMICS</u> <u>OF THE MESOSPHERIC AND LOWER ATMOSPHERIC</u> <u>REGIONS (EXPERIMENT AS-4)</u> | A-5 |
| 1.4.1 SCIENTIFIC OBJECTIVES. | A-5 |
| 1.4.2 METHODS. | A-5 |
| 1.4.3 INSTRUMENTS REQUIRED | A-6 |
| 1.4.4 ORBIT AND TIMELINE CONSTRAINTS | A-6 |

| Section | Page |
|---|------|
| 1.5 <u>DETERMINE THE EDDY DIFFUSION BETWEEN THE ALTITUDES OF 85 km and 120 km (EXPERIMENT AS-5)</u> | A-7 |
| 1.5.1 SCIENTIFIC OBJECTIVES. | A-7 |
| 1.5.2 METHODS. | A-7 |
| 1.5.3 INSTRUMENTS REQUIRED | A-8 |
| 1.5.4 ORBIT AND TIMELINE CONSTRAINTS | A-8 |
| 2.0 EXPERIMENTS INVOLVING PHOTOCHEMICAL REACTIONS IN THE UPPER ATMOSPHERE | A-9 |
| 2.1 <u>DETERMINE ATMOSPHERIC INTERACTIONS OF EXCITED RADICALS (EXPERIMENT AS-6)</u> | A-9 |
| 2.1.1 SCIENTIFIC OBJECTIVES. | A-9 |
| 2.1.2 METHODS. | A-9 |
| 2.1.3 INSTRUMENTS REQUIRED | A-9 |
| 2.1.4 ORBIT AND TIMELINE CONSTRAINTS | A-10 |
| 2.2 <u>DETERMINE ATOMIC AND MOLECULAR OXYGEN DENSITIES BETWEEN 90 km and 120 km ALTITUDES (EXPERIMENT AS-7)</u> | A-10 |
| 2.2.1 SCIENTIFIC OBJECTIVES. | A-10 |
| 2.2.2 METHODS. | A-10 |
| 2.2.3 INSTRUMENTS REQUIRED | A-10 |
| 2.2.4 ORBIT AND TIMELINE CONSTRAINTS | A-11 |
| 2.3 <u>DETERMINE SOLAR RADIATION INTERACTION WITH THE AMBIENT ATMOSPHERE (EXPERIMENT AS-8)</u> | A-11 |
| 2.3.1 SCIENTIFIC OBJECTIVES. | A-11 |
| 2.3.2 METHODS. | A-11 |
| 2.3.3 INSTRUMENTS REQUIRED | A-12 |
| 2.3.4 ORBIT AND TIMELINE CONSTRAINTS | A-12 |

| Section | Page |
|--|------|
| 2.4 <u>DETERMINE THE ATMOSPHERIC CONSTITUENT ABUNDANCE BELOW 120 km ALTITUDE (EXPERIMENT AS-9)</u> | A-12 |
| 2.4.1 OBJECTIVE. | A-13 |
| 2.4.2 METHODS. | A-13 |
| 2.4.3 INSTRUMENTS REQUIRED | A-13 |
| 2.4.4 ORBITAL AND TIMELINE CONSTRAINTS | A-14 |
| 2.5 <u>DETERMINE THE ATMOSPHERIC CONSTITUENT ABUNDANCE ABOVE 120 km ALTITUDE (EXPERIMENT AS-10)</u> | A-14 |
| 2.5.1 SCIENTIFIC OBJECTIVES. | A-14 |
| 2.5.2 METHODS. | A-14 |
| 2.5.3 INSTRUMENTS REQUIRED | A-15 |
| 2.5.4 ORBITAL AND TIMELINE CONSTRAINTS. | A-15 |
| 3.0 EXPERIMENTS INVOLVING PARTICLE INTERACTIONS IN THE UPPER ATMOSPHERE | A-16 |
| 3.1 <u>DETERMINE CHANGE IN THE IONOSPHERIC D REGION DUE TO SEASONAL ANOMALIES AND MAGNETIC STORMS (EXPERIMENT AS-11)</u> | A-16 |
| 3.1.1 SCIENTIFIC OBJECTIVES. | A-16 |
| 3.1.2 METHODS. | A-16 |
| 3.1.3 INSTRUMENTS REQUIRED | A-17 |
| 3.1.4 ORBIT AND TIMELINE CONSTRAINTS | A-17 |
| 3.2 <u>DETERMINE THE METALLIC CONSTITUENTS IN THE UPPER ATMOSPHERE (EXPERIMENT AS-12)</u> | A-17 |
| 3.2.1 SCIENTIFIC OBJECTIVES. | A-17 |
| 3.2.2 METHODS. | A-17 |
| 3.2.3 INSTRUMENTS REQUIRED | A-18 |
| 3.2.4 ORBIT AND TIMELINE CONSTRAINTS | A-18 |

| Section | Page | |
|---------|--|------|
| 3.3 | <u>EVALUATE DEPOSITION OF METEORIC DUST AND METALLIC CONSTITUENTS (EXPERIMENT AS-13)</u> | A-18 |
| 3.3.1 | SCIENTIFIC OBJECTIVE | A-18 |
| 3.3.2 | METHODS. | A-18 |
| 3.3.3 | INSTRUMENTS REQUIRED | A-19 |
| 3.3.4 | ORBIT AND TIMELINE CONSTRAINTS | A-19 |
| 3.4 | <u>DETERMINE THE METEORIC PRODUCTION OF NITRIC OXIDE (EXPERIMENT AS-14)</u> | A-19 |
| 3.4.1 | SCIENTIFIC OBJECTIVES. | A-19 |
| 3.4.2 | METHODS. | A-19 |
| 3.4.3 | INSTRUMENTS REQUIRED | A-20 |
| 3.4.4 | ORBIT AND TIMELINE CONSTRAINTS | A-20 |
| 3.5 | <u>INVESTIGATE THE EXCITATION EXCHANGE BETWEEN METASTABLE SPECIES AND THE AMBIENT ENVIRONMENT (EXPERIMENT AS-15)</u> | A-21 |
| 3.5.1 | SCIENTIFIC OBJECTIVES. | A-21 |
| 3.5.2 | METHODS. | A-21 |
| 3.5.3 | INSTRUMENTS REQUIRED | A-22 |
| 3.5.4 | ORBITAL AND TIMELINE CONSTRAINTS | A-22 |
| 4.0 | ATMOSPHERE EXCITATION INPUT. | A-23 |
| 4.1 | <u>SOLAR FLUX MONITOR</u> | A-23 |
| 4.1.1 | SCIENTIFIC OBJECTIVES. | A-23 |
| 4.1.2 | METHODS. | A-23 |
| 4.1.3 | INSTRUMENTS REQUIRED | A-23 |
| 4.1.4 | ORBIT AND TIMELINE CONSTRAINTS | A-23 |
| 4.2 | <u>PARTICLE FLUX MONITORING SUBSATELLITE</u> | A-23 |
| 4.2.1 | SCIENTIFIC OBJECTIVES. | A-23 |

Section

Page

| | | |
|-------|--|------|
| 4.2.2 | METHODS | A-24 |
| 4.2.3 | INSTRUMENTS REQUIRED | A-24 |
| 4.2.4 | ORBIT AND TIMELINE CONSTRAINTS | A-24 |

1.0 WIND, TEMPERATURE AND DIFFUSION EXPERIMENTS

1.1 IDENTIFY PROPERTIES OF NATURAL TRACERS (Experiment AS-1)

1.1.1 SCIENTIFIC OBJECTIVES

This experiment will identify those naturally occurring atmospheric constituents which may be used as temperature and wind indicators.

1.1.2 METHODS

The principal sources of data will be from downward and horizon looking spectroscopy. Instrument 118 will be required to operate continuously during a mission to obtain global coverage, scanning the atmosphere from the horizon to about 100 to 200 kilometers altitude. The response of the instrument should permit the determination of the relative quantities of those infrared emitting molecular species such as H_2O , NO , N_2O , CH_4 , CO_2 and others.

Instrument 213 will be required to operate continuously during the mission to obtain the desired global coverage. At the normal orbital altitudes for the Orbiter, the instrument will be pointed toward nadir. The orbit altitudes are above the atmospheric levels (90 to 200 kilometers) at which the majority of the particles exist in which laser induced emissions occur. The system will operate at a rate of one pulse per second. It is anticipated that laser emission will stimulate emission from various species in the ionosphere which can be detected by the spectrally selective interferometer receiver and permit some evaluation of the presence of strongly emitting ions. Instrument 124 will have the spectral range to detect the short (2000 to 3600 Å) wavelength emissions of the atomic and molecular species. In support of the data from Instrument 118 and the induced emission of Instrument 213, Instrument 124 will look at the limb and the nadir on alternate revolutions. Instrument 126 will also alternate

between the limb and the nadir to supplement the above spectral data with those to be observed in the infrared region. The data from instruments 118, 124, and 126, spectral line sensing systems, is expected to permit determination of the predominant natural molecular and atomic species in the lower ionosphere up to the regions near the orbiting vehicle altitudes. The three instruments employ internal calibration sources that are automatically used in the operational sequence. Periodically during the mission, Instrument 118 will use the space background in a direction approximately normal to the ecliptic to obtain a check reference on a 4 Kelvin background. This reference check should occur, for example, midway on the dark side for approximately three minutes on a few revolutions.

Instrument 532 will be used to determine the spectral characteristic of various interesting gaseous species, that are yet to be selected, when acted upon by solar radiation under the environmental conditions existing in the ionosphere at the orbital altitude. This device will provide reference spectra for the selected gases for comparison with those measured in the ambient atmosphere. It is desirable to operate the instruments near the midpoint on the sunlit part of a revolution for several revolutions.

1.1.3 INSTRUMENTS REQUIRED

| <u>Number</u> | <u>Name</u> |
|---------------|-----------------------------------|
| 118 | Limb Scanning Infrared Radiometer |
| 124 | Fabry-Perot Interferometer |
| 126 | Infrared Interferometer |
| 213 | Laser Sounder |
| 532 | Gas Release Module |

1.1.4 ORBIT AND TIMELINE CONSTRAINTS

This experiment can be performed at any available orbital altitudes and inclination and requires complete global mapping of the earth within the orbital track, ultimately to cover the entire earth.

1.2 MEASURE WINDS AND TEMPERATURE FIELDS (Experiment AS-2)

1.2.1 SCIENTIFIC OBJECTIVES

This experiment will measure wind and temperature fields in the upper atmosphere on a global scale using the tracers found suitable in experiment 1.1.

1.2.2 METHODS

Gas temperatures are derived from the doppler-broadening of emission lines while scalar flow is found from doppler shifting of these lines. Instrument 118 is operated continuously during the mission, scanning from the horizon to between 100 to 200 kilometers altitude. This instrument will measure abundances of infrared emitting molecular species in excited states.

Winds in the mesosphere and thermosphere will be determined from the excitation by nadir pointing Instrument 213 of ambient species and determination of the doppler shifted return radiation, by the detection of the doppler shift in the emission of the natural excited species, by resonant scatter of incident sunlight, and by the drifts of the emission irregularities due to either natural or laser excitation in the natural occurring species. The sensitivity to the scalar flow of these instruments will probably not be less than ± 25 meters/second.

Instrument 124 will be used looking toward the limb, using the 5577 Å spectral line for altitudes from 90 to 200 kilometers, and

the 6300 Å line for 200 to 370 kilometers to give the gas kinetic temperature through line profile broadening.

Instrument 126 will provide similar thermal data through line spreading of prominent trace species determined in the previous experiment.

1.2.3 INSTRUMENTS REQUIRED

| <u>Number</u> | <u>Name</u> |
|---------------|-----------------------------------|
| 118 | Limb Scanning Infrared Radiometer |
| 124 | Fabry-Perot Interferometer |
| 126 | Infrared Interferometer |
| 213 | Laser Sounder |

1.2.4 ORBIT AND TIMELINE CONSTRAINTS

This experiment is applicable to all available orbit altitudes and inclinations. It should be performed at all available inclinations to broaden coverage and achieve global mapping of the field's distribution.

1.3 PROFILE THE ATMOSPHERE TEMPERATURE IN THE REGION OF 15 km to 120 km ALTITUDE (Experiment AS-3)

1.3.1 SCIENTIFIC OBJECTIVES

This experiment will measure the vertical temperature profile on a world-wide basis for altitudes from 15 to 120 kilometers.

1.3.2 METHODS

Temperatures are inferred from spectral line broadening. Measurements of a similar nature have been made from unmanned satellites with downward looking infrared spectrometers observing a carbon dioxide absorption edge. Instrument 118 will look at the limb in order to detect the infrared emitting molecular species. Instrument 124 pointing at the limb will be used to give gas

kinetic temperatures through vibration-rotation line spreading of the CO₂ line at 2.7 micrometers. In addition, the 5577 Å line of the oxygen transition night glow for the 90 to 130 kilometers altitudes will give the gas temperature on the night side.

With Instrument 126 pointed at the nadir and covering the 6 to 25 micrometer spectral region, the interferogram can be unfolded to give a reasonably detailed temperature profile. Instrument 213 will be used to conduct active vertical sounding to excite atmospheric sodium emissions from which the line broadening will be observed.

1.3.3 INSTRUMENTS REQUIRED

| <u>Number</u> | <u>Name</u> |
|---------------|-----------------------------------|
| 118 | Limb Scanning Infrared Radiometer |
| 124 | Fabry-Perot Interferometer |
| 126 | Infrared Interferometer |
| 213 | Laser Sounder |

1.3.4. ORBIT AND TIMELINE CONSTRAINTS

This experiment is applicable to all orbit altitudes and inclinations. Instrument restrictions are the same as for experiment 1.1.

1.4 DETERMINE THE THERMAL STRUCTURE AND DYNAMICS OF THE MESOSPHERIC AND LOWER ATMOSPHERIC REGIONS (Experiment AS-4)

1.4.1 SCIENTIFIC OBJECTIVES

This experiment will attempt to establish the relationship between the previously described temperature and wind measurements and the solar excitation inputs.

1.4.2 METHODS

The temperature and wind profiles found in experiments 1.2 and 1.3 will be combined with solar flux, Birkeland current, and particle

precipitation measurements. Long wavelength infrared measurements will be required for energy balance calculation. Albedo estimates will be made with Instrument 122 and the photometer aboard the PDS.

Instrument 118 looking at earth limb will be used to investigate the infrared emitting species as reference bases. Instrument 122 looking at nadir will measure the upwelling radiation as an input to the total energy budget. The measurements of Instrument 126 in the nadir pointing mode will be used to evaluate the long wavelength infrared region of the returning radiation spectrum. The particle subsatellite supplies the budgetary input due to both incoming particles of solar origin as well as those reflected back up from the atmosphere and from the magnetic field convergence. Instrument 1002 will provide the calibration reference of the local solar input levels for the SPS.

1.4.3 INSTRUMENTS REQUIRED

| <u>Number</u> | <u>Name</u> |
|---------------|-----------------------------------|
| 118 | Limb Scanning Infrared Radiometer |
| 122 | UV-VIS-NIR Spectrometer |
| 126 | Infrared Interferometer |
| 1002 | Pyrheliometer/Spectrometer |

Data from the PDS and SPS.

1.4.4 ORBIT AND TIMELINE CONSTRAINTS

This experiment is applicable to all available orbit altitudes and should be performed at inclinations of such latitude as to permit global coverage.

1.5 DETERMINE THE EDDY DIFFUSION BETWEEN THE ALTITUDES OF
85 km and 120 km (Experiment AS-5)

1.5.1 SCIENTIFIC OBJECTIVES

This experiment will attempt to define the rates of eddy diffusion, wind and turbulence in atmospheric mixing phenomena.

1.5.2 METHODS

Temperature and wind measurements will be based on the doppler techniques of experiments 1.2 and 1.3. Diffusions will be measured by vertical profiling of selected constituents. Gas release measurements and particle subsatellite data baselines will be required for data reductions.

Eddy diffusion coefficients in the high mesosphere and lower thermosphere will be determined from the temporal spread of injected gaseous species from Instrument 532. The spread will be monitored by the observed induced emissions. It also may be estimated from measurements of the local structure function exhibited in the fluctuations of natural airglow emission from ambient species. Instrument 118 will monitor those emissions of interest in the infrared region. In both limb and nadir pointing directions, instruments 122, 124, and 126 will be continuously observing the airglow. In addition, Instrument 213, pointed at nadir will be needed to induce emissions in the ambient constituents or the released gases in the event the naturally induced emission is not strong enough for detection.

1.5.3 INSTRUMENTS REQUIRED

| <u>Number</u> | <u>Name</u> |
|---------------|------------------------------------|
| 118 | Limb Scanning Infrared Radiometer |
| 122 | UV-VIS-NIR Spectrometer/Photometer |
| 124 | Fabry-Perot Interferometer |
| 126 | Infrared Interferometer |
| 213 | Laser Sounder |
| 532 | Gas Release Module |

Data from the PDS.

1.5.4 ORBIT AND TIMELINE CONSTRAINTS

This experiment is applicable to all orbits and inclinations until global mapping of the eddy diffusion is obtained.

2.0 EXPERIMENTS INVOLVING PHOTOCHEMICAL REACTIONS
IN THE UPPER ATMOSPHERE

2.1 DETERMINE ATMOSPHERIC INTERACTIONS OF EXCITED RADICALS
(Experiment AS-6)

2.1.1 SCIENTIFIC OBJECTIVES

Significant portions of the total thermal energy in the upper atmosphere is believed to be held in molecular levels which do not possess radiative transitions. Excitation transfer by intermediates such as CO₂ and hydroxyl radicals leads to radiative transfer. This experiment will ascertain the magnitude by which the transfer mechanism influences the overall thermal budget.

2.1.2 METHODS

OH vibrational levels may be measured by induced fluorescence in the near ultraviolet. Collision excitation transfer will be estimated by comparing the measured level populations to theoretical populations in the absence of energy transfer. In a limb pointing attitude, Instrument 116 will register the transitions in the 300 Å to 2000 Å region. Instrument 1011 will evaluate the population as a function of the absorption lines of sources occulted by the earth's horizon. Instrument 122 will observe radiations stimulated by the emissions of Instrument 213 in a nadir pointing direction. All instruments will operate throughout the mission.

2.1.3 INSTRUMENTS REQUIRED

| <u>Number</u> | <u>Name</u> |
|---------------|--------------------------------------|
| 116 | Airglow Spectrograph |
| 122 | UV-VIS-NIR Spectrometer/Photometer |
| 213 | Laser Sounder |
| 1011 | Ultraviolet Occultation Spectrograph |

2.1.4 ORBIT AND TIMELINE CONSTRAINTS

This experiment is suitable for any orbit altitude and inclination. Global coverage is desired.

2.2 DETERMINE ATOMIC AND MOLECULAR OXYGEN DENSITIES BETWEEN 90 km and 120 km ALTITUDES (Experiment AS-7)

2.2.1 SCIENTIFIC OBJECTIVES

The purpose of this experiment is to make precise determinations of the dissociation of oxygen in the 90 to 120 km region as a function of geographical position, time-of-day, season, solar, and particle inputs.

2.2.2 METHODS

Concentrations will be measured spectrographically with supporting data from the SPS and PDS systems. High spectral resolution measurements by instruments 124 and 1011 during solar occultation will provide a direct determination of atomic oxygen. The 5577 Å emission will provide a measure of density as detected by Instrument 122 pointing near nadir. Using Instrument 213 in a nadir pointing attitude, the nitric oxide fluorescence radiating at the 2150 Å line which is induced by the laser emission and detected by instruments 122 and 124 can be used to further infer the densities of atomic and molecular oxygen.

2.2.3 INSTRUMENTS REQUIRED

| <u>Number</u> | <u>Name</u> |
|---------------|--------------------------------------|
| 122 | UV-VIS-NIR Spectrometer/Photometer |
| 124 | Fabry-Perot Interferometer |
| 213 | Laser Sounder |
| 1011 | Ultraviolet Occultation Spectrograph |

Supporting data from the SPS and PDS.

2.2.4 ORBIT AND TIMELINE CONSTRAINTS

This experiment is applicable to all available orbits and timelines and will require data from multiple flights for seasonal and geographic coverage.

2.3 DETERMINE SOLAR RADIATION INTERACTION WITH THE AMBIENT ATMOSPHERE (Experiment AS-8)

2.3.1 SCIENTIFIC OBJECTIVES

This experiment will identify spectral transitions of long lived metastable states which are pressure or wall quenched in ground based experiments. As such it will provide necessary baseline data for other ASF experiments.

2.3.2 METHODS

Clouds of neutral molecules will be released for spectrographic measurements. Preionized species will be ejected by the accelerator instruments. Various gases that are to be investigated for metastable states under orbital conditions will be released and analyzed within the instrument analysis chamber by Instrument 532. The analyses will be made to determine the degree of ionization or photon capture and emission that occurs for each gaseous material due to the solar radiation at orbital attitudes. The gases will also be released into free space and an attempt to detect the spectral transitions of the species will be made by instruments 122, 124 and 532 pointing at the release area. Further excitation attempts will be made using the electron and plasma accelerators, instruments 303 and 304, to provide the stimulus. These will be conducted on the dark side of the revolutions in order to enhance the spectral selectivity in the detection of the artificial excitation. These emissions will be observed by instruments 122, 124, 532 and 1011. Instrument 549 will provide a gaseous test subject and also provide a level one diagnostic tool for monitoring the shape of the accelerator beam emissions. The monitoring will be done

using Instrument 1011. Instrument 550 will provide second level diagnosis of beam structure through a real measurement of intensity. Instrument 536 will provide a measure of the magnetic field line direction for control of the accelerator beams. Accelerator operation should not be required for more than about 15 revolutions to achieve the objective of this experiment.

2.3.3 INSTRUMENTS REQUIRED

| <u>Number</u> | <u>Name</u> |
|---------------|---|
| 122 | UV-VIS-NIR Spectrometer/Photometer |
| 124 | Fabry-Perot Interferometer |
| 213 | Laser Sounder |
| 303 | Electron Accelerator |
| 304 | Magnetoplasmdynamic (MPD) Arc |
| 532 | Gas Release Module |
| 534 | Optical Band Imager and Photometer System |
| 536 | Triaxial Fluxgate |
| 549 | Gas Plume Release |
| 550 | Level II Beam Diagnostics Group |

Supporting data from the SPS.

2.3.4 ORBIT AND TIMELINE CONSTRAINTS

Gas release experiments must be performed in direct sunlight for solar excitation. This experiment should have no orbital altitude or inclination restrictions. Vehicle attitude with respect to the local magnetic field must be such that the accelerated particles do not impinge on the vehicle during accelerator operation.

2.4 DETERMINE THE ATMOSPHERIC CONSTITUENT ABUNDANCE BELOW 120 km ALTITUDE (Experiment AS-?)

2.4.1 OBJECTIVE

This experiment will attempt to synoptically map the geographic distributions and vertical profile of atomic, molecular and ionic abundance between 15 and 120 km.

2.4.2 METHODS

Oxygen, nitrogen and their compounds can be determined from airglow measurements. Ultraviolet and infrared measurements will be required for ions and polyatomic species. Laser excitation will be used in creating promptly radiating states or short lived forms. Instrument 118 provides data that will be used in analysis of atmospheric constituent contribution of such species as ozone, NO_2 , NO , and N_2O as well as a basis for inferring the thermal state. Instruments 122, 124 and 126 in the limb scanning mode provide data on the various chlorine compounds and complexes that are present as well as those of nitrogen. Instrument 213 excitation in the nadir direction will produce resonant fluorescence for further substantiating evidence of oxygen, chlorine, and the hydroxyl radicals. Instrument 1011 operating during the periods when the terminator is approached on several revolutions will provide absorption profiles from which composition may be inferred. Operation of the instruments except as noted should be for the entire mission.

2.4.3 INSTRUMENTS REQUIRED

| <u>Number</u> | <u>Name</u> |
|---------------|--------------------------------------|
| 118 | Limb Scanning Infrared Radiometer |
| 122 | UV-VIS-NIR Spectrometer/Photometer |
| 124 | Fabry-Perot Interferometer |
| 126 | Infrared Interferometer |
| 213 | Laser Sounder |
| 1011 | Ultraviolet Occultation Spectrograph |

Supporting data from the SPS and PDS.

2.4.4 ORBITAL AND TIMELINE CONSTRAINTS

This experiment should be applicable to all orbital altitudes and inclinations. Since the composition is a function of latitude, both polar and equatorial measurements to provide global coverage will be required.

2.5 DETERMINE THE ATMOSPHERIC CONSTITUENT ABUNDANCE ABOVE 120 km ALTITUDE (Experiment AS-10)

2.5.1 SCIENTIFIC OBJECTIVES

This experiment is the counterpart of experiment 2.4 for altitudes comparable to and above the spacecraft orbit. These data will help toward a better understanding of the dynamic and chemical processes at these altitudes.

2.5.2 METHODS

Data will be gathered primarily by occultation and upward looking spectroscopy. The inversion technique of estimating spherical shell contributions based on changing angular absorption will be used to determine constituent distribution. Instrument 122 pointing toward the horizon will measure the resonance scattered solar radiation, particularly in the 1216 Å lines, from which the compositional variations of helium and hydrogen, respectively, in the upper atmospheric regions may be inferred. Instrument 124, pointing in the same direction as Instrument 122, will observe the gamma bands of NO at 2150 Å. Instrument 1011 pointing at the terminator for several revolutions will use the occultation absorption of ionizing ultraviolet radiation by atomic and molecular oxygen and nitrogen to infer their concentration. These data are desired throughout the mission except as noted.

2.5.3 INSTRUMENTS REQUIRED

| <u>Number</u> | <u>Name</u> |
|---------------|--------------------------------------|
| 122 | UV-VIS-NIR Spectrometer/Photometer |
| 124 | Fabry-Perot Interferometer |
| 1011 | Ultraviolet Occultation Spectrograph |

Supporting data from the SPS and PDS.

2.5.4 ORBITAL AND TIMELINE CONSTRAINTS

This experiment should be applicable to all available orbits and inclinations. Global coverage is desirable.

3.0 EXPERIMENTS INVOLVING PARTICLE INTERACTIONS IN THE UPPER ATMOSPHERE

3.1 DETERMINE CHANGE IN THE IONOSPHERIC D REGION DUE TO SEASONAL ANOMALIES AND MAGNETIC STORMS (Experiment AS-11)

3.1.1 SCIENTIFIC OBJECTIVES

This experiment will correlate the changes in neutral composition, neutral species temperature, radicals and particle flux to D region propagation.

3.1.2 METHODS

Nitric oxide, water vapor, hydrated radicals, ozone and atomic oxygen abundance and temperature will be measured by the spectrographic and laser probe techniques described in earlier experiments. Particle fluxes will be simultaneously measured for correlation purposes and to assess their import on regions of high precipitations such as the south Atlantic anomaly and the high latitudes. Infrared limb radiance profiles with Instrument 126 in the 1 to 16 micrometers range as well as 64 micrometers for lines due to water, carbon dioxide, ozone, and atomic oxygen will be used to infer composition distribution. Resonance scattering of the visible solar radiation by hydrogen, nitrogen and hydroxyl radicals will be detected by instruments 122 and 124 pointing near nadir to provide data from which these concentrations will be inferred. Airglow emissions of atomic and molecular nitrogen should be seen under both sunlit and dark conditions. The airglow emissions result from excitation transfer, resonance scattering, fluorescence, chemical association, or photoelectron impact, either due to natural causes or artificial excitation by Instrument 213 pointing near nadir. Particle data are obtained continuously from the subsatellite.

3.1.3 INSTRUMENTS REQUIRED

| <u>Number</u> | <u>Name</u> |
|---------------|------------------------------------|
| 122 | UV-VIS-NIR Spectrometer/Photometer |
| 124 | Fabry-Perot Interferometer |
| 126 | Infrared Interferometer |
| 213 | Laser Sounder |

Supporting data from the PDS.

3.1.4 ORBIT AND TIMELINE CONSTRAINTS

Particle precipitation and seasonal anomalies are high latitude effects making a near polar orbit highly desirable. Global coverage is a requirement.

3.2 DETERMINE THE METALLIC CONSTITUENTS IN THE UPPER ATMOSPHERE (Experiment AS-12)

3.2.1 SCIENTIFIC OBJECTIVES

The purpose of this experiment is to provide baseline data on the quantity and distribution of metals in the upper atmosphere.

3.2.2 METHODS

Primary information will be in the form of spectrographic data. Resonant backscatter from laser probing is a promising data source. Techniques that are presently available will probably only measure a limited portion of total inventory. It is proposed that the distribution of metallic ions and neutral species be determined from measurements by instruments 124 and 1011 observing the limb profile of resonantly scattered solar radiation as well as from the backscatter of the output from Instrument 213 in a nadir pointing direction. Aerosols and noctilucent clouds have been suggested as contributors to the metallic content and will be investigated with measurements by

Instrument 116. Instruments 122, 124, and 126 pointing near nadir provide continuous sources of data on the resonance radiations from metallic species. Instrument 1011 registers the various absorption spectra relating to these constituents during the occultation observations for a limited number of revolutions. Data on the particle flux are continuously obtained to provide basic information for the analysis of the experiment results.

3.2.3 INSTRUMENTS REQUIRED

| <u>Number</u> | <u>Name</u> |
|---------------|--------------------------------------|
| 116 | Airglow Spectrograph |
| 122 | UV-VIS-NIR Spectrometer/Photometer |
| 124 | Fabry-Perot Interferometer |
| 126 | Infrared Interferometer |
| 213 | Laser Sounder |
| 1011 | Ultraviolet Occultation Spectrograph |

Supporting data from the SPS and PDS.

3.2.4 ORBIT AND TIMELINE CONSTRAINTS

This experiment is applicable to all orbit altitudes and inclinations. Instrument timelines will be similar to experiments 2.3 and 2.4 which use generally similar instrument complements.

3.3 EVALUATE DEPOSITION OF METEORIC DUST AND METALLIC CONSTITUENTS (Experiment AS-13)

3.3.1 SCIENTIFIC OBJECTIVE

This experiment will determine changes in the metallic content of the upper atmosphere due to meteor showers.

3.3.2 METHODS

This experiment is an extension of experiment 3.2 and will use basically the same data acquisition methods. To be successfully

accomplished, an appropriately located meteor shower must occur. Due to this restriction, this experiment must be placed in a "target-of-opportunity" category despite the fundamental nature of the objectives. The instruments will be used in the same manner and will measure the same parameters as in experiment 3.2.

3.3.3 INSTRUMENTS REQUIRED

| <u>Number</u> | <u>Name</u> |
|---------------|------------------------------------|
| 122 | UV-VIS-NIR Spectrometer/Photometer |
| 124 | Fabry-Perot Interferometer |
| 126 | Infrared Interferometer |
| 213 | Laser Sounder |

Supporting data from SPS and PDS.

3.3.4 ORBIT AND TIMELINE CONSTRAINTS

Mission planning will require planning for an appropriate meteor shower. A low inclination orbit is most probable of success.

3.4 DETERMINE THE METEORIC PRODUCTION OF NITRIC OXIDE (Experiment AS-14)

3.4.1 SCIENTIFIC OBJECTIVES

This experiment is expected to determine the amount of nitric oxide formed in the 90 to 120 km altitude region by ionizing tracks of meteors after detecting the tracks with low light level television (Instrument 534).

3.4.2 METHODS

Quantitative determination of nitric oxide will be attempted using laser induced fluorescence. It may be possible to quantitatively monitor the reactants spectroscopically during the

shower. This experiment must be relegated to the same "target-of-opportunity" category as the previous experiment 3.3. In addition, recent analytical results have indicated that in less than three seconds following the advent of a meteor shower, the basic nitric oxide content will exhibit less than one percent deviation at the site of the passage from the concentration existing prior to the shower. The possibility of measurements under such circumstances provides reason for an effort since this analytical result is considered controversial.

Should the circumstances arise in which the Orbiter is in such a position that the trail of an appropriately sized meteor, something on the order of one gram, is close enough to be viewed for three seconds after the initial entry into a level of about 150 kilometers, this experiment could be attempted. The trail will be tracked using Instrument 534 and photometric measurements made with passive evaluation of the nitric oxide content attempted by instruments 124 and 126 pointed at the track location. If conditions should exist where the Orbiter passes nearly above the meteor track, active probing with Instrument 213 will be attempted to observe induced emissions.

3.4.3 INSTRUMENTS REQUIRED

| <u>Number</u> | <u>Name</u> |
|---------------|---|
| 122 | UV-VIS-NIR Spectrometer/Photometer |
| 124 | Fabry-Perot Interferometer |
| 126 | Infrared Interferometer |
| 213 | Laser Sounder |
| 534 | Optical Band Imager and Photometer System |

3.4.4 ORBIT AND TIMELINE CONSTRAINTS

The orbit and launch data restrictions of this experiment are identical to experiment 3.3.

3.5 INVESTIGATE THE EXCITATION EXCHANGE BETWEEN METASTABLE SPECIES AND THE AMBIENT ENVIRONMENT (Experiment AS-15)

3.5.1 SCIENTIFIC OBJECTIVES

This experiment will study excitation and quenching cross sections at orbital altitudes with pressure levels and instrument volumes not available in ground laboratories.

3.5.2 METHODS

Gas clouds will be released as plumes or plasmoids and excited by the ambient photons and particle fluxes or by active probing with electron beams. Fluorescent decay will be observed with imaging devices and the spectrographic complement onboard the Orbiter.

The accelerators, instruments 303 and 304, will be used to excite gas clouds that are released by instruments 532 and 549. The gas releases also will serve as first level diagnostic tools in determining the accelerator output beam shapes. Second level beam evaluations will be accomplished by use of Instrument 550 scanning the output beam areas to map the output intensity distributions. Visual evaluation of the beam-gas interaction will be monitored by Instrument 534 which also will be used for photometric measurements of the induced emissions. Instruments 116, 122, 124 and 126 will observe the fluorescent decay of the excited species to evaluate the exchange of energy between the various species. Instrument 536 will provide the magnetic field line direction to ensure proper control of the beam trajectories. Accelerator usage should not be required to exceed about 15 orbits of the mission in order to accomplish the objectives of this experiment.

3.5.3 INSTRUMENTS REQUIRED

| <u>Number</u> | <u>Name</u> |
|---------------|---|
| 116 | Airglow Spectrograph |
| 122 | UV-VIS-NIR Spectrometer/Photometer |
| 124 | Fabry-Perot Interferometer |
| 126 | Infrared Interferometer |
| 303 | Electron Accelerator |
| 304 | Magnetoplasdynamic (MPD) Arc |
| 532 | Gas Release Module |
| 534 | Optical Band Imager and Photometer System |
| 536 | Triaxial Fluxgate |
| 549 | Gas Plume Release (Level I Diagnosis) |
| 550 | Level II Beam Diagnostics Group |

3.5.4 ORBITAL AND TIMELINE CONSTRAINTS

This experiment should be performed at more than one orbital altitude. Low orbit inclinations will minimize natural particle inputs. Vehicle attitude with respect to the local magnetic field lines must be such that the accelerated electrons or ions do not impinge on the Orbiter vehicle during accelerator operation.

4.0 ATMOSPHERE EXCITATION INPUT

4.1 SOLAR FLUX MONITOR

4.1.1 SCIENTIFIC OBJECTIVES

Long term (on the order of the eleven year solar cycle) monitoring of the vacuum ultraviolet to visible wavelength energy inputs as needed for understanding cyclic variations in the atmosphere. Short term measurements of the solar flux are required to perform I/O balance calculations.

4.1.2 METHODS

A small, moderate spectral resolution instrument will be launched as a piggy-back load on a sun synchronous satellite. Periodic calibration of this device will be accomplished by carrying an identical unit aboard the Orbiter.

4.1.3 INSTRUMENTS REQUIRED

| <u>Number</u> | <u>Name</u> |
|---------------|----------------------------|
| 1002 | Pyrheliometer/Spectrometer |

4.1.4 ORBIT AND TIMELINE CONSTRAINTS

This instrument support is applicable to all missions. A daylight revolution at the beginning and at the end of the mission will suffice to provide the necessary calibration data.

4.2 PARTICLE FLUX MONITORING SUBSATELLITE

4.2.1 SCIENTIFIC OBJECTIVES

Energy input due to particle flux and Birkeland currents is required to perform atmospheric energy balance calculations.

4.2.2 METHODS

The particle and current measurements are exceedingly delicate and subject to vehicle EMI. Therefore, the instruments will be deployed at a distance between 1 km and 10 km from the Orbiter by a free flying, recoverable subsatellite. The vehicle and instruments proposed are essentially the same as an existing AE satellite. The system will be operated in a spin-stabilized attitude.

4.2.3 INSTRUMENTS REQUIRED

AE satellite modified to accomplish storage and recovery aboard the Orbiter vehicle equipped with the following existing sensors:

- a. CEP - Langmuir Probe (Cylindrical Electrostatic Probe)
- b. RPA - Planar Ion Trap
- c. PES - Photoelectron Spectrometer
- d. LEID - Low Energy Ion Detector He^+ and O^+
- e. LEE - Low Energy Electron Probe
- f. NACE - Neutral Mass Spectrometer
- g. NATE - Neutral Atmospheric Temperature
- h. HEPD - High Energy Particle Detector
- i. VAE - Airglow Photometer
- j. CCIG - Cold Cathode Ion Gauge
- k. MAG - Triaxial Fluxgate

4.2.4 ORBIT AND TIMELINE CONSTRAINTS

The particle flux monitoring subsatellite will be useful in all orbit inclinations. Data will be especially critical from high latitude and polar orbits. The satellite will be deployed

early in the mission, kept on station, then recovered before reentry of the Orbiter.

APPENDIX B
INSTRUMENT DESCRIPTIONS

CONTENTS

| Instrument Number | | Page |
|----------------------|---|--------|
| 116 | AIRGLOW SPECTROGRAPH. | 116-1 |
| 118 | LIMB SCANNING INFRARED RADIOMETER | 118-1 |
| 122 | ULTRAVIOLET-VISIBLE-NEAR-INFRARED SPECTROMETER. | 122-1 |
| 124 | FABRY-PEROT INTERFEROMETER. | 124-1 |
| 126 | INFRARED INTERFEROMETER | 126-1 |
| 213 | LASER SOUNDER | 213-1 |
| 303 | ELECTRON ACCELERATOR. | 303-1 |
| 304 | MAGNETOPLASMDYNAMIC (MPD) ARC. | 304-1 |
| 532 | GAS RELEASE MODULE. | 532-1 |
| 534 | OPTICAL BAND IMAGER AND PHOTOMETER SYSTEM (OBIPS) | 534-1 |
| 536 | TRIAxIAL FLUXGATE | 536-1 |
| 549 | GAS PLUME RELEASE (AMPS PARTICLE ACCELERATOR SYSTEM LEVEL I DIAGNOSTIC). | 549-1 |
| 550 | FARADAY CUP PROBE RETARDING POTENTIAL ANALYZER COLD PLASMA PROBE (AMPS PARTICLE ACCELERATOR SYSTEM LEVEL II DIAGNOSTICS). | 550-1 |
| 1002 | PYRHELIOMETER AND SPECTROPHOTOMETER | 1002-1 |
| 1011 | ULTRAVIOLET OCCULTATION SPECTROGRAPH. | 1011-1 |

AIRGLOW SPECTROGRAPH

INSTRUMENT 116

OBJECTIVE

The Airglow Spectrograph will be used to study upper atmospheric emissions and absorptions in the vacuum ultraviolet region (300 to 2000 Å). The specific observations to be performed are as follows:

- a. High spectral resolution (less than or equal to 2 Å) and high spatial resolution spectrography of the day airglow, night airglow, tropical airglow, polar aurorae, artificial aurorae, polar cap glows, as well as ultraviolet emissions of the neutral exosphere (e.g., H and He) and of the plasmasphere and ionosphere (He^+ , O^+).

Primary emphasis will be on the nearly unexplored wavelength range below 1100 Å, containing the resonance lines of He, He^+ , N^+ , N_2 , and Ar; but there is also great need to obtain better spectral resolution and more complete spatial and temporal coverage in the 1100 to 2000 Å range (P, N, N_2 , Lyman-Birge-Hopfield, CO Fourth Positive, CO_2^+ , OH, and NO).

- b. Studies of time-variant phenomena in the upper atmosphere (as produced by gravity waves, thermospheric winds, tides, etc.) through their effects on the emission and/or absorption spectra.
- c. Detailed comparison and investigation of the interrelationships between phenomena in the plasmasphere and in the polar aurorae and between airglow emissions and solar ultraviolet and X-ray flux.

The ultimate results of the spectra to be obtained in a, b, and c above are concentrations and, in many cases, temperature and excitation mechanisms of various atmospheric species as a function of altitude, geographic location, time, and solar activity (as expressed both in electromagnetic radiation and in the solar wind and energetic particles).

- d. Studies of the spectra of releases at high altitudes of materials such as water, ammonia, and liquid hydrogen and of rocket exhaust plumes. Such studies will yield information on the interactions of

these hot and cold gases with solar ultraviolet radiation and with chemically active species in the upper atmosphere. They will also contribute to the understanding of comets, other planetary atmospheres, and gaseous nebulae.

GENERAL DESCRIPTION

LOCATION

This instrument will be located on a pallet.

CONFIGURATION

The Airglow Spectrograph will use a microchannel intensifier stage to provide ultimate sensitivity for weak airglow emissions. Single photoelectron events will be readily measurable, and emissions as weak as one Rayleigh can be detected in exposure times of 5 min or less. The instrument will cover the 300- to 2000-Å wavelength range with 2-Å resolution, but (by the use of a higher dispersion grating) higher resolution can be obtained (as may be necessary for determination of temperatures from the rotational structure of molecular bands) over correspondingly narrower spectral ranges.

The Airglow Spectrograph will have two modes of operation. The first (configuration A) will involve use of the instrument without any external optics, in which case the only reflecting surface will be the concave grating. This will provide maximum sensitivity, especially in the wavelength range below 950 Å, where the reflectance of all known reflective coatings is less than 30 to 35 percent. However, the field of view will be about 5° square, which will limit the spatial resolution to this amount. The second mode (configuration B) will involve the use of a collimating mirror, which will give much better spatial resolution but reduced sensitivity because of an additional reflecting surface. A 1-m focal length collimator will give a field of view determined by the size of the slit (0.85° x 0.006° for a 15- x 0.1-mm slit giving 2-Å resolution). See figure 116-1 for the overall concept.

ORIGINAL PAGE IS
OF POOR QUALITY

116-3

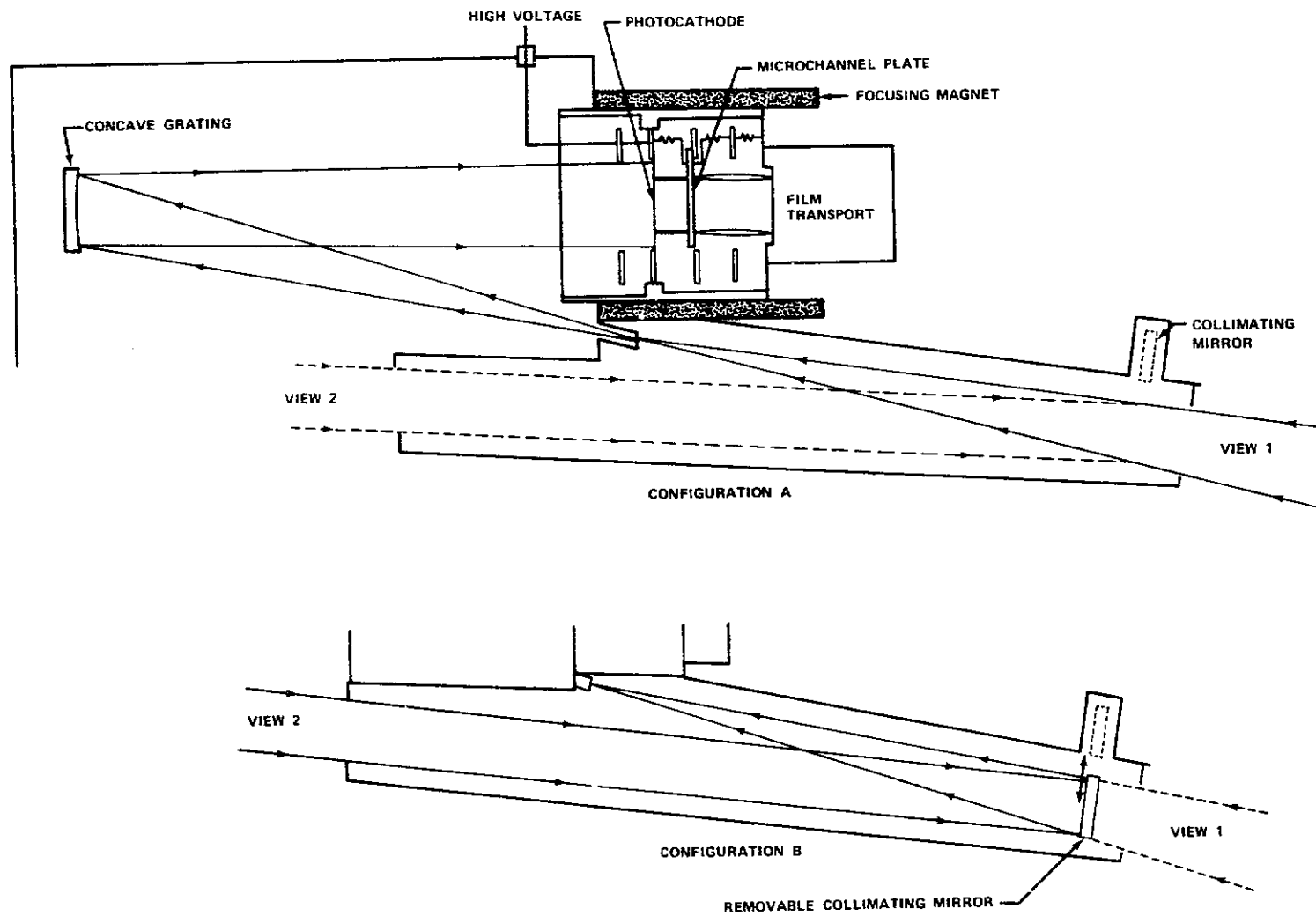

Figure 116-1. - Airglow Spectrograph (concept).

SPECIFICATIONS

Physical Measurements: The spectral range of the Airglow Spectrograph will be 300 to 2000 Å with the instrument in configuration A; in configuration B, the spectral range will be approximately 950 to 2000 Å, due to the inability of the collimating mirror coating to reflect the lower wavelengths.

Resolution:

Spectral: less than or equal to 2 Å

Spatial: 5° (configuration A), 1° (configuration B)

Sensitivity: optimized with respect to background signal level from scattered light

Field of View: The field of view of configuration A will be 5° square, while that of configuration B will be 1° square.

Data Collection Rate: The exposure times for spectrograms range from 1 sec to as much as 1000 sec. This permits greater integration of the energy on the spectrographic image.

Power: 28 Vdc: 10 W (standby), 10 W (operating)

Physical Dimensions:

Size: 0.6 m diam x 2 m length, 0.56 cu m

Weight: 30 kg

Other:

Optics: The collimating mirror can be moved into and out of the optical path during flight; the concave grating cannot be changed in flight.

Cooling: There will be no unique cooling requirements.

Shading: A hood will be required to shield the optics from earthshine.

OPERATION

POINTING REQUIREMENTS

The Airglow Spectrograph may be pointed anywhere from zenith through the horizontal to the nadir for operation; the pointing accuracy error must be less than or equal to 0.5°.

STABILIZATION AND TRACKING REQUIREMENTS

The stabilization error should be less than or equal to 15 arc sec.

TIMELINE

The frequency of operation will be governed by the occurrence of discrete events, e.g., aurorae, and by the existence of observable conditions, e.g., noctilucent clouds. In addition, studies of normal dayglow and nightglow will dictate operation at frequent intervals during a mission. The duration of a given data take will be dependent upon the nature of the phenomena under observation; weak emissions will require photographic exposures as long as 5 min at a time. The emissive strength of an observed area will be the major determinant in establishing the duration of a data take.

CONSTRAINTS

The instrument's magnetic field may interfere with other instruments in the payload bay; further, the spectrograph will be susceptible to external magnetic fields and to the proximity of ferromagnetic materials. The high voltage power supply must not be energized when the ambient pressure is greater than 10^{-6} torr. The interior of the instrument must be protected against humidity levels greater than 10 percent relative humidity during prelaunch and launch operations.

CHECKOUT AND TEST

BORESIGHTING REQUIREMENTS

The instrument will be boresighted to the remotely controlled platform with an accuracy of 20 arc min. Co-alignment with the Ultraviolet Occultation

Spectrograph (Instrument 1011) will be a function of the pointing accuracy error differences between the platforms on which the instruments will be mounted; the basic requirement will be for a co-alignment error less than or equal to 30 arc min.

PRELAUNCH CHECKOUT

Prelaunch checkout will be confined to the use of discrete test signal inputs provided by Ground Support Equipment (GSE) and the measurement and analysis of the output data trains after the input signals have been processed through the instrument.

PREFLIGHT CALIBRATION

Preflight calibration of the Airglow Spectrograph will not be possible, since the instrument can function properly only in a vacuum environment. Calibrations obtained during the fabrication and test of the spectrograph will, of necessity, become the prelaunch calibration baseline.

INFLIGHT CALIBRATION

Inflight calibration of the spectrograph will not be contemplated.

CONTROLS

Control of the Airglow Spectrograph will include the following facets:

- a. Power to place the instrument in standby and operate modes.
- b. Mirror shift to shift the collimating mirror into and out of the energy path (i.e., to change configuration).
- c. Exposure control to control the start and duration of the exposure of the spectrogram.

DISPLAYS

The display for crew evaluation will include the following:

- a. Indication of the optical configuration of the instrument
- b. Relative pointing angle

- c. Indication of the completion of the spectrogram exposure
- d. Indication of exhaustion of the film supply

DATA

SCIENTIFIC DATA

Scientific data will consist of a spectrogram recorded on photographic film in the Airglow Spectrograph. The film, Kodak type NTB-3, Nuclear Track Recording Film, will be 35 mm in width, and 100 ft in length; although the exact image area of the spectrogram is to be determined, that length of film will allow for 700 or more spectrograms.

HOUSEKEEPING DATA

In addition to Orbiter ephemeris data, housekeeping data will be generated as analog signals in six 8-bit words, sampled at the rate of 480 bps.

Included will be the following items:

- a. Relative pointing angle
- b. Indication of the optical configuration
- c. High-voltage power level
- d. Indications of start and completion of spectrogram exposure

DEVELOPMENT STATUS

FORERUNNER INSTRUMENTS

Spectrographs similar to the proposed Airglow Spectrograph have been launched and successfully flown on missions using sounding rockets as vehicles. In these instances, the instrument was installed in an evacuated chamber within the rocket body, with an outside cover which could not be opened until the operating altitude of 150 to 400 km was reached.

PROBLEMS

Design and Manufacturing: The high-voltage power supply must be protected against the incidence of corona for atmospheric pressures greater than 10^{-6} torr. A second problem will be that of protecting the instrument from stray magnetic fields of greater than 1 gauss; fluctuating magnetic fields will be especially degrading to the instrument. Protection against electromagnetic interference (EMI), both as a radiative source and a susceptible victim, will be essential.

Operational: In addition to protection against stray magnetic fields, which will be a continuing requirement throughout the mission, there will be a period of delay before the first data take to assure that all outgassing has ended before the high-voltage power supply is energized. Contamination of the optics of the spectrograph will be a continuing threat.

Detailed studies are needed to determine the required spectral resolutions and optimum wavelength ranges for the absorption and emission spectrography of the various atmospheric gases.

LIMB SCANNING INFRARED RADIOMETER

INSTRUMENT 118

OBJECTIVE

The Limb Scanning Infrared Radiometer will acquire data to permit measurement of trace species at altitudes up to 120 km. Through its ability to scan vertically from the horizon upward, the multichannel configuration of the radiometer will enable the evaluation of the vertical distribution of the trace gases. Calculations indicate that the instrument should allow measurement of H₂O to an altitude of 93 km, of O₃, NO, N₂O, and CH₄ to about 110 km, and HNO₃, NO₂, and CO to altitudes determined by their concentrations. In addition to the named gases, the radiometer can be used to analyze the concentrations of allotropes of oxygen; oxides of nitrogen, hydrogen, and chlorine; and compounds of carbon, chlorine, and sulfur.

GENERAL DESCRIPTION

LOCATION

This instrument will be mounted on a pallet.

CONFIGURATION

The radiometer will have a large, cold telescope designed to collect data in the spectral range of 3 to 40 μ m. Through exchange of the detector/bandpass filter combination, the range could be extended to 62 μ m, under some circumstances. The outer housing of the radiometer will be of dewar configuration to contain the cryogen which will maintain the internal components at the requisite low temperature. The maximum number of detectors will be 12. The detectors will consist mainly of gold-doped germanium or copper-doped germanium; the doping level for the detectors will differ in order to tailor the response to specific spectral ranges when coupled with discrete interference filters. A system of chopping the incoming energy will complete the receptor configuration.

The optical component of the radiometer will be a large-aperture Cassegrainian telescope which will form the collecting optics; the aperture will be 60 to 100 cm in size and will be cooled to cryogenic temperature as will the remainder of the instrument. A nutating mirror will perform the scanning function and will direct the incoming radiation through the collecting optics and the collimating system to a diffraction grating. From the diffraction grating, the dispersed energy will impinge on the multiple detectors, which will be the signal generating components of the instrument. The scanning mirror will have the capability to affect a vertical scan, i.e., from horizon to the upper altitude limit; in addition, the mirror will have the capability to simultaneously sweep up to 10° either side of the nominal pointing position of the instrument. The azimuthal sweep will be incremental, allowing for vertical sawtooth scan patterns at discrete angles to the side. See figure 118-1 for the overall concept.

SPECIFICATIONS

Spectral Characteristics:

Wavelength range: 3 to 40 μm

Sensitivity: 1-to-5 $\times 10^{-12}$ $\text{W cm}^{-2} \text{sr}^{-1} \mu\text{m}^{-1}$

Signal-to-noise ratio: (TBD)

Dynamic range: 10^9

Spectral resolution: (TBD)

Off-axis rejection: (TBD, $\geq 10^{-6}$)

Field of View: Instantaneous field of view (IFOV) of 0.02° is desirable; 0.08° will be acceptable. An internal nutating mirror will scan the IFOV over the vertical field of the instrument's viewing area; additionally, the nutating mirror will scan up to 10° each side of the nominal pointing position. The vertical scan rate will be 1 deg/sec; the azimuthal scan rate will be (TBD) deg/sec.

Data Collection Rate: Data can be taken over a continuous time period.

118-3

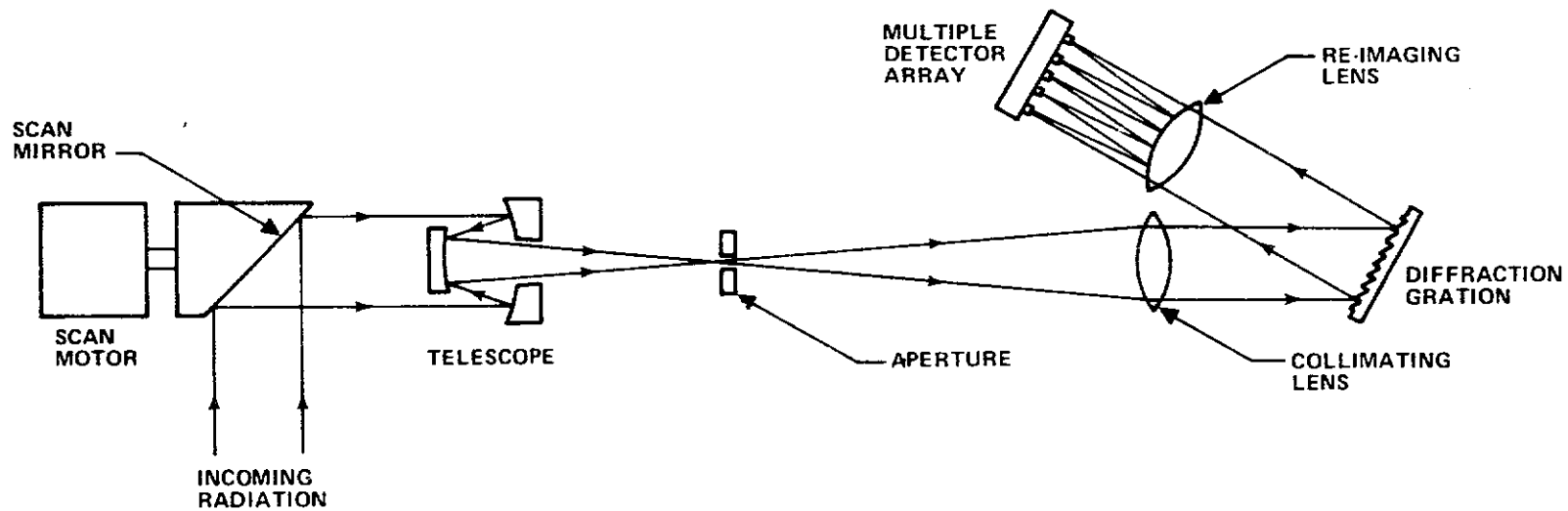

Figure 118-1. - Limb-Scanning Infrared Radiometer (concept).

Power: 115 Vac, 400 Hz: 15 W (standby), 100 W (operating)

Physical Dimensions:

Size: 0.8 m diam x 1.8 m; 0.9 cu m

Weight: 115 kg plus 185 kg for cryogen, dewar, and plumbing

Other:

Window: A window of suitable transmission characteristics will be required at the entrance to the instrument; the window material must be resistant to the effects of the cryogenic temperature of the compartment which it will enclose.

Cooling aspects: The instrument housing will be of dewar construction to maintain the internal components at the proper low temperature (77 K or 28 K, depending upon the cryogen used). The detector must be cooled to 4 K for operation.

OPERATION

POINTING REQUIREMENTS

Pointing accuracy of 0.5° will be required.

STABILIZATION AND TRACKING REQUIREMENTS

Stabilization to within 15 arc sec will be acceptable; there will be no tracking requirement.

TIMELINE

The radiometer will operate from the dark side of the terminator, and the data taking period during a scan cycle will range from 40 sec at the fastest scan rate to 66 sec at the slowest scan rate.

CONSTRAINTS

A major constraint will be the requirement that the instrument be operated through all planned cycles before the supply of cryogen has been exhausted.

CHECKOUT AND TEST

BORESIGHTING REQUIREMENTS

The radiometer must be boresighted to the remotely controlled platform with a maximum error of 0.1° ; additionally, it will require co-alignment with the Infrared Interferometer (Instrument 126) and with the Laser Sounder (Instrument 213) with a maximum error of 0.1° .

PRELAUNCH CHECKOUT

The instrument will be checked through use of a ground support equipment (GSE) signal generator which will originate input test signals to be conditioned and processed through the radiometer electronics; the output data train will be examined and analyzed for indication of anomalous conditions.

PREFLIGHT CALIBRATION

None.

INFLIGHT CALIBRATION

The instrument will use an internal source of blackbody emission and the cold of outer space for the periodic inflight calibrations; the calibration procedures will be required at somewhat frequent intervals, probably at the start and/or completion of each scan cycle.

CONTROLS

Control of the radiometer will include the following facets:

- a. Power to place the instrument in standby and operate modes.
- b. Scan rate to select the rate at which the scan mechanism will operate; also, to select the angle of scan.

- c. Scan mode to select the mode in which the scan mechanism will function (i.e., sawtooth, zig-zag, sinusoidal).
- d. Calibration for inflight calibration update.
- e. Cryogen to top-off the dewar instrument as required.

Pointing control will be exercised through maneuvering of the remotely controlled stabilized platform and/or through slaving to other instruments; separate control will not be required.

DISPLAYS

The display for crew evaluation will include:

- a. Indication of selected scan rate and scan angle
- b. Indication of scan mode
- c. Display of data from 4 to 12 spectral channels
- d. Relative pointing angle of radiometer

DATA

SCIENTIFIC

The scientific data will be comprised of 12-bit digital words, recorded at the rate of 12 kbps. The principal items of data will be the radiance data, scan rate and angle, and scan mode; calibration data obtained inflight will be included.

HOUSEKEEPING

In addition to Orbiter ephemeris data, housekeeping data will be generated as analog signals with six 8-bit words, sampled at the rate of 480 bps.

Included will be the following items:

- a. Relative pointing angle
- b. Detector temperature and bias voltage

- c. Telescope temperature
- d. Status of cryogen supply (two signals)

DEVELOPMENT STATUS

FORERUNNER INSTRUMENTS

A smaller noncryogenic radiometer with lesser capability will operate on the Nimbus "F" spacecraft. Unmanned satellites in recent years have carried, as payloads, radiometers which are somewhat similar to the instrument described herein, although they were of a lesser degree of sophistication. As a result, the Limb-Scanning Infrared Radiometer can be considered to be developed beyond the "experimental" category.

PROBLEMS

Design and Manufacturing: Among the problems of design will be the protection against off-axis interference and the assurance of suitable spectral rejection. A mechanical design problem will be that of minimizing heat leaks and cryogen leaks and of maintaining a proper cryogenic temperature within the instrument. Determination of the need for a window and the selection of appropriate window material will require attention.

Operational: The foremost operational problem will be that of protecting against contamination of the optics of the instrument; this will still be the case if an infrared-transparent window is interposed in the energy path. Additionally, the susceptibility of the detector circuits to electromagnetic interference (EMI) will dictate the timeline of usage of the instrument, so as to avoid interference from EMI-generating instruments. The matter of exhaustion of the cryogen supply has been mentioned previously.

ULTRAVIOLET-VISIBLE-NEAR-INFRARED SPECTROMETER

INSTRUMENT 122

OBJECTIVE

The Ultraviolet-Visible-Near-Infrared (UV-VIS-NIR) Spectrometer-Photometer will obtain measurements of natural and induced atmospheric and ionospheric emissions in wavelengths ranging from 1100 to 10,000 Å. The instrument will monitor the concentration of nitric oxide produced by meteors and meteor showers and will aid in the study of the photochemistry of oxygen at altitudes of 100 km and greater. Another objective will be to assist in the spectroscopy of the reactions between released helium and oxygen gases by measuring the emissions and/or absorptions of the interreactions.

GENERAL DESCRIPTION

LOCATION

This instrument will be located on a pallet.

CONFIGURATION

The instrument will consist of four to eight small spectrometers to cover the entire spectral range, each optimized by choice of grating ruling and photocathode to provide maximum sensitivity in slightly less than one octave of the spectrum. The small spectrometers will be similar to the 12.5 cm Ebert spectrometer proposed for spacecraft use. The use of multiple miniaturized spectrometers rather than a single spectrometer with interchangeable gratings will permit the simultaneous observation of several spectral features.

The basic configuration will consist of four spectrometers; a second bank of four spectrometers can be used with integral Cassegrainian telescopes to provide a rectangular field of view useful for limb-scanning experiments.

The detectors will be EMR 510 ceramic photomultiplier tubes (PMT's) sealed and potted in integrated assemblies and will operate in a pulse-counting mode.

The temperature range of the PMT's will be -20° to $+50^{\circ}$ C, and the operating pressure can be anywhere between one atmosphere and hard vacuum.

SPECIFICATIONS

Physical Measurements: The four spectrometers will operate in these spectral bands: 1100 to 1800 Å, 1800 to 3400 Å, 3400 to 6000 Å, and 6000 to 10,000 Å.

Resolution: Spectral resolution will be 10 Å when observing UV spectral features and 25 Å when observing in the visible and near infrared. The spatial resolution will be $12^{\circ} \times 12^{\circ}$.

Sensitivity: Two photoelectrons sec^{-1} Rayleigh $^{-1}$ in the UV and slightly higher in the visible and NIR ranges. The dark count rate will be approximately 0.5 photoelectrons sec^{-1} at the spectral range of 1100 to 1800 Å and considerably higher for the visible and NIR ranges.

Field of View: The field of view of the basic configuration will be $12^{\circ} \times 12^{\circ}$. The field of view will be $1.0^{\circ} \times 0.1^{\circ}$ for limb scanning with the second bank of spectrometers.

Data Collection Rate: Two modes of operation are available:

- a. Spectral scanning, in which a full scan will be completed every 10 sec. Data will be recorded every 20 ms so that there will be 3 to 4 data samples per spectral element.
- b. Fixed wavelength operation, in which a fixed grating angle will permit the spectrometer to be used as a narrow bandwidth photometer. The data sampling rate can be as high as the detector count rate.

Power: 28 Vdc: 16 W (standby), 16 W (operating)

Physical Dimensions:

Size: 0.5 x 0.2 x 0.2 m, 0.02 cu m

Weight: 16 kg

Other:

Cooling: There will be no unique cooling requirements, although the PMT's must be connected to the cooling loop in the payload bay.

Off-Axis rejection: (TBD)

Polarization: (TBD)

Protective cover: A protective cover will be required to guard against contamination of the instrument optics.

Telescope: Each separate spectrophotometer will have a Cassegrainian telescope of 250-mm effective focal length.

Detectors: Both long and short wave spectrometers will use similar detectors, EMR 510G and EMR 510F, which are identical with the exception of spectral response characteristics and dark count. The associated power supplies will provide a maximum of 2000 V for the PMT's.

OPERATION

POINTING REQUIREMENTS

Pointing accuracy of approximately 0.1° will be adequate.

STABILIZATION AND TRACKING REQUIREMENTS

The allowable error in stabilization will be less than or equal to 0.1° .

TIMELINE

(TBD)

CONSTRAINTS

Direct viewing of the sun must be avoided, and protective covers must not be opened when contaminating agents are in the vicinity of the optics. Ground operations must take place under conditions of suitably low light levels to avoid permanent degradation of the detectors.

CHECKOUT AND TEST

BORESIGHTING REQUIREMENTS

The spectrometer will be boresighted to the remotely controlled pallet platform with a maximum error of 0.1°.

PRELAUNCH CHECKOUT

The spectrometer will be checked through use of a GSE signal generator which will generate input test signals which will be conditioned and processed through the instrument electronics; the output data train will be examined and analyzed for indication of anomalous conditions.

PREFLIGHT CALIBRATION

A GSE test set will simulate inflight energy emissions which will be directed into the spectrometers. The output data to be derived will form the baseline calibration data for the instrument.

INFLIGHT CALIBRATION

(TBD)

CONTROLS

Control of the spectrometer will include the following facets:

- a. Power to place the instrument in standby and operate modes.
- b. Mode select to select spectrometer mode.
- c. Scan rate select to select rate of grating scan.
- d. Wavelength select to establish a grating position for the selection of a specific wavelength.
- e. Microprocessor control for program modification.

DISPLAYS

The display for crew evaluation will include the following:

- a. Indication of the selection of mode, scan rate, and wavelength for a given data take
- b. Cathode-ray tube (CRT) display of detector counts as a function of integration time
- c. Indication of relative pointing angle of instrument

DATA

SCIENTIFIC

One 16-bit digital word will be sampled at the rate of 1 kbps for each spectrometer. The principal data product output rate will be 8 kbps.

HOUSEKEEPING

In addition to Orbiter ephemeris data, the housekeeping data will consist of three 8-bit analog words per spectrometer sampled at the rate of 40 bps per spectrometer. The full complement of eight spectrometers will result in a total of twenty-four 8-bit words and a sampling rate of 320 bps.

DEVELOPMENT STATUS

FORERUNNER INSTRUMENTS

Individual spectrometers scanning the 1100 to 1800 Å and the 1800 to 3200 Å spectral regions have successfully flown on several sounding rocket flights. A satellite version of the proposed instrument is scheduled to be flown on the Naval Research Laboratory SOLRAD 11 satellite in November 1975.

PROBLEMS

Design and Manufacturing: No significant problems are foreseen in the development of the spectrometer; the small spectrometers to be incorporated into the overall instrument will be adaptations of existing instruments.

Operational: There will be no unusual problems connected with operation of the spectrometer.

FABRY-PEROT INTERFEROMETER

----- INSTRUMENT 124

OBJECTIVE

The objectives of the instrument are three-fold:

- a. Mode 1 — Interferometric observations will provide Doppler velocity and temperature measurements in the mesosphere and thermosphere using selected atomic line emissions in the ultraviolet (UV), visible, and near infrared spectral regions. Laser resonance back-scatter will be observed in this mode.
- b. Mode 2 — High resolution, high etendu photometric studies will be made of line and band emissions from less than 0.2 to 10 μm . These measurements will be made primarily in a limb-scanning mode and used for qualitative measurements of minor species (both natural and manmade) of the stratosphere, mesosphere, and thermosphere. The instrument will offer extremely high rejection of interfering continuum, band, and line emissions.
- c. Mode 3 — By adding two-dimensional array sensors, the instrument will be used as an imaging interferometer, photometer to provide three-dimensional mapping of mesospheric and thermospheric velocity, temperature, and intensity distributions.

GENERAL DESCRIPTION

LOCATION

This instrument will be mounted on a pallet.

CONFIGURATION

Since three modes of operation are foreseen and the objectives are widely different, a separate description is given of each.

Mode 1 – Interferometer: A 25-cm clear aperture Fabry-Perot Interferometer will be used for investigating the thermal and dynamic structure of the mesosphere and thermosphere.

Mode 2 – Photometer: The tandem combination of two fully tunable etalons with a small number of 100 Å bandpass filters will provide a completely adjustable variable frequency filter, bandwidth 1 Å, which can scan any wavelength between the range of less than 0.2 and 1 μm. The instrument can operate in a spectrometer mode or as a photometer or differential photometer. With the exception of the bandpass filter and the horizon scanning system, there will be no moving parts within the system. Filter apertures between 5 and 25 cm will be used, giving an extremely large throughput and the possibility of accurately measuring radiations as feeble as 10^{-3} Rayleigh with a 1 Å bandwidth and a time constant of 1 sec.

Mode 3 – Infrared Photometer: A configuration of two tandem tunable etalons of infrared transmitting materials (wavelengths up to 12 or 15 μm) will operate as a very flexible infrared radiometer.

The scanning system will be comprised of a plane mirror for limb/horizon scanning through a 90° azimuth range. The optical quality of the mirror will be less than or equal to $\lambda/10$ from a true plane.

A telescope with a reduction factor from 3 to 5 will be used to reduce the demands of size and volume on the scanning mirror system and the associated earthshine baffle.

Standard bandpass filters (0.1 μm bandwidth in the visible and 1 μm bandwidth in the infrared) will be used for coarse spectral selection in all modes. A relatively small number of filters (3 to 4) will be used, although the optimum location in the optical path has not been established.

Each etalon will be comprised of a pair of Fabry-Perot plates which will be optically contacted and piezoelectrically scanned. Parallelism and wavelength scanning will be controlled electronically, and a wavelength accuracy of 0.5 percent of the free spectral range can be achieved for a particular etalon. For flexibility in a photometer mode, two etalons in tandem are to be used. The optimum overall finesse of each etalon in this mode will be approximately 30. The combination can form a resolution of 1 \AA , resettable wavelength accuracy of 0.15 \AA , and a usable free spectral range without overlap of approximately 1000 \AA .

For the 0.5- to $1\text{-}\mu\text{m}$ region, the lens design will be relatively simple. For use in the infrared, requirements will be more complex but will be attainable with present materials and methods.

State-of-the-art detectors include photomultipliers with trialkali and gallium arsenide photocathodes. For infrared operations, pyroelectric sensors will offer the optimum combination of sensitivity, flatness of spectral response, and ease of use. For detection of weak signals, however, liquid helium-cooled detectors will offer the ultimate performance.

For both interferometry and photometry, new developments in solid state array detectors (e.g., charged coupled detectors (CCD), electrographic cameras) will offer exciting possibilities of three-dimensional analysis of temperature, velocities, and densities.

SPECIFICATIONS

Physical Measurements:

Spectral range: $0.2 \mu\text{m}$ to greater than $10 \mu\text{m}$

Bandwidth: Mode 1 (interferometer) $\Delta\lambda/\lambda$ approximating 10^{-6}

Mode 2 and 3 (photometer) for various operations $10^{-5} < \Delta\lambda/\lambda < 10^{-3}$

Resolution: Spatial resolution in the limb scanning mode will consist of:

- a. Vertical resolution – 3 to 10 km
- b. Horizontal resolution – 200 to 100 km depending on altitude, field of view, and other matters

Sensitivity:

- a. Mode 1 (interferometer) – range of 0.2 to 1 μm , signal will approximate 25 detected photons $\text{sec}^{-1} \text{Rayleigh}^{-1}$
- b. Mode 2 (photometer) – range of 0.2 to 1 μm , 1- \AA bandwidth signal will approximate 5×10^4 detected photons $\text{sec}^{-1} \text{Rayleigh}^{-1}$
- c. Mode 2 (photometer) – range of 0.2 to 1 μm , 10- \AA bandwidth signal will approximate 5×10^6 detected photons $\text{sec}^{-1} \text{Rayleigh}^{-1}$
- d. Mode 3 (IR photometer/radiometer) – range of 1 to 10 μm , detector dependent

Field of View:

- a. Mode 1 (interferometer) – 0.11° to 0.17°
- b. Modes 2 and 3 (photometer) – 0.57° to 2.86°
- c. Modes 1 and 2 (array) – 10 x 100 elements, 0.11° to 0.28°

Data Collection Rate: (TBD)

Power: 28 Vdc: 14 W (standby), 14 W (operating)

Physical Dimensions:

Size: Interferometer – 0.3 x 0.5 x 0.7 m, 0.1 cu m

Weight: total system – 45 kg (estimated)

Other:

Detectors:

- a. UV-visible – low noise/high efficiency photomultiplier tubes (PMT)
- b. Infrared – photodiode, cryogenic thermistor, bolometer, pyroelectric detector, as specified
- c. Imaging – CCD or other matrix array detector

Cooling: Connection to the payload bay cooling loop will be adequate for the photomultiplier detectors. Thermoelectric cooling or cryogenic cooling will be required for the infrared detectors.

Polarization: Instrument will not be sensitive to polarization.

Off-axis rejection: Greater than or equal to 10^{-6} ; rejection of scattered earthlight and sunlight should be approximately 10^{-11}

Dynamic range: Photon counting rates to 10^8 per sec. Infrared flux $10^6:1$.

OPERATION

POINTING REQUIREMENTS

In the limb-scanning operation, the instrument will scan from parallel to a tangent plane to a depression angle of about 20° to scan the region in orthogonal directions for orbits below 400 km. Pointing errors must be less than or equal to 1.14° , with a reading resolution of 0.05° . When the instrument operates in conjunction with the Laser Sounder (Instrument 213) the co-alignment error must not exceed 0.05° .

STABILIZATION AND TRACKING REQUIREMENTS

(TBD)

TIMELINE

The Interferometer will be used throughout the mission, on a continuous basis, or as required to complement the operation of other instruments.

CONSTRAINTS

None, other than protection of the instrument against degradation of the optical components when contaminants are in the vicinity.

CHECKOUT AND TEST

BORESIGHTING REQUIREMENTS

The instrument must be boresighted to the remotely controlled platform with a maximum error of less than or equal to 0.05° .

PRELAUNCH CHECKOUT

(TBD)

PREFLIGHT CALIBRATION

Prelaunch calibration will be accomplished during acceptance testing of the instrument. Calibration subsequent to installation on the remotely controlled platform will be limited to verification of selected throughput parameters.

INFLIGHT CALIBRATION

Integral spectral/radiance calibration lamps will be used routinely throughout the mission to calibrate the instrument.

CONTROLS

Control of the Interferometer will include the following facets:

- a. Power to place the instrument into standby and operate modes.
- b. Mode select to select one of the three operating modes of the instrument.
- c. Scan rate to select the rate at which the instrument will scan the area under observation.

Pointing control will be exercised through operation of the remotely controlled platform on the payload bay pallet; separate control will not be required.

DISPLAYS

The display for crew evaluation will include cathode-ray tube (CRT) presentation of the instrument output data for periodic monitoring of quality, especially during operations in conjunction with the Laser Sounder (Instrument 213).

DATA

SCIENTIFIC

The scientific data, which will consist of 200 8-bit digital words recorded at the rate of 1.6 kbps, will be comprised of interferometer diagnostics and the parameters for plotting intensity as a function of wavelength.

HOUSEKEEPING

In addition to Orbiter ephemeris data, housekeeping data will be generated as analog signals in seven 8-bit words sampled at the rate of 560 bps.

Included will be the following items:

- a. Indication of operating mode selected
- b. Calibration of photomultiplier tube (PMT) dark current
- c. Voltage of PMT power supply
- d. Detector temperature
- e. Relative pointing angle
- f. Calibration data
- g. Integration time

DEVELOPMENT STATUS

FORERUNNER INSTRUMENTS

Fabry-Perot interferometers having etalons as large as 5 cm in diameter have been successfully flown in rockets; these instruments have utilized ruggedized piezoelectric scanning etalons, such as considered for the subject instrument. The optical and electronic development of instruments for

satellite flight has advanced so that many examples of the necessary technology currently exist.

PROBLEMS

Design and Manufacturing: The foremost problem will be that of fabricating the etalons. Attaining the required flatness of approximately $\lambda/200$ in the diameter specified will be an advancement in the state-of-the-art in optical work. A second problem, also attributable to the large size of the etalon, will be that of "scanning" the etalon without distorting the flats and with the ability to return the flats to the fundamental parallel separation. Instrument versatility can be improved by the use of crystalline materials with transmission over greater wavelength ranges and by use of better dielectric coatings for the etalons.

Operational: No significant operational problems are anticipated.

INFRARED INTERFEROMETER

INSTRUMENT 126

OBJECTIVE

The Infrared Interferometer will acquire data in the spectral region ranging from 1 to 150 μm , in four discrete intervals. The instrument will incorporate interchangeable filter/beamsplitter/detector combinations to cover each of the four spectral ranges; each combination will be assembled into the instrument prior to flight and will remain fixed for a given mission.

GENERAL DESCRIPTION

LOCATION

This instrument will be mounted on a pallet.

CONFIGURATION

The Interferometer will be a Michelson configuration, with the optical path folded to permit reduction of the overall size of the instrument. The entire instrument will be encased in a dewar which will contain the cryogen (liquid nitrogen, or possibly, liquid hydrogen) to maintain the components at operating temperature and to minimize or eliminate the effects of emission from internal components.

The collecting optic will be a 60-cm aperture, afocal Cassegrainian telescope which will direct the incoming energy to the internal beamsplitter. From the beamsplitter, the energy will be divided so that part is focused on the detector through a series of fixed mirrors and the balance is reflected to a moving mirror and then back through the fixed mirrors to the same detector. The moving mirror will oscillate slowly and precisely to alter the path length which will provide interferometric patterns relative to the beam which will be reflected directly to the detector. Considerations for the detectors include mercury-doped cadmium-telluride for wavelengths up to 50 μm and an indium-antimonide bolometer for wavelengths beyond 50 μm . Both types of

detectors must be cooled to operate at liquid helium temperatures (i.e., 4 K). See figure 126-1 for the overall concept.

SPECIFICATIONS

See table 126-1 for the specifications of the four configurations.

Field of View: 0.1° (for all configurations)

Data Collection Rate: The data collection period will approximate 3 min per data take.

Power: 115 Vac, 400 Hz: 10 W (standby), 25 W (operating)

Physical Dimensions:

Size: 0.9 m diam x 0.7 m long; 0.45 cu m

Weight: 114 kg plus 186 kg for cryogen, dewar, and plumbing

Other:

Window: A window of suitable infrared transmission characteristics will be required at the entrance to the collecting optics; the window material must be resistant to the effects of the cryogenic temperature of the interior of the collecting optics compartment.

Cooling aspects: The instrument housing will be of dewar construction to maintain the internal components at the proper low temperature (77 K or 28 K, depending upon the cryogen used). The detector must be cooled to 4 K for operation.

OPERATION

POINTING REQUIREMENTS

When pointed at the earth limb, the pointing error must be less than or equal to 0.1°. When pointing at areas between the limb and nadir, the accuracy requirement is less stringent; accuracy of approximately 0.4° will be acceptable.

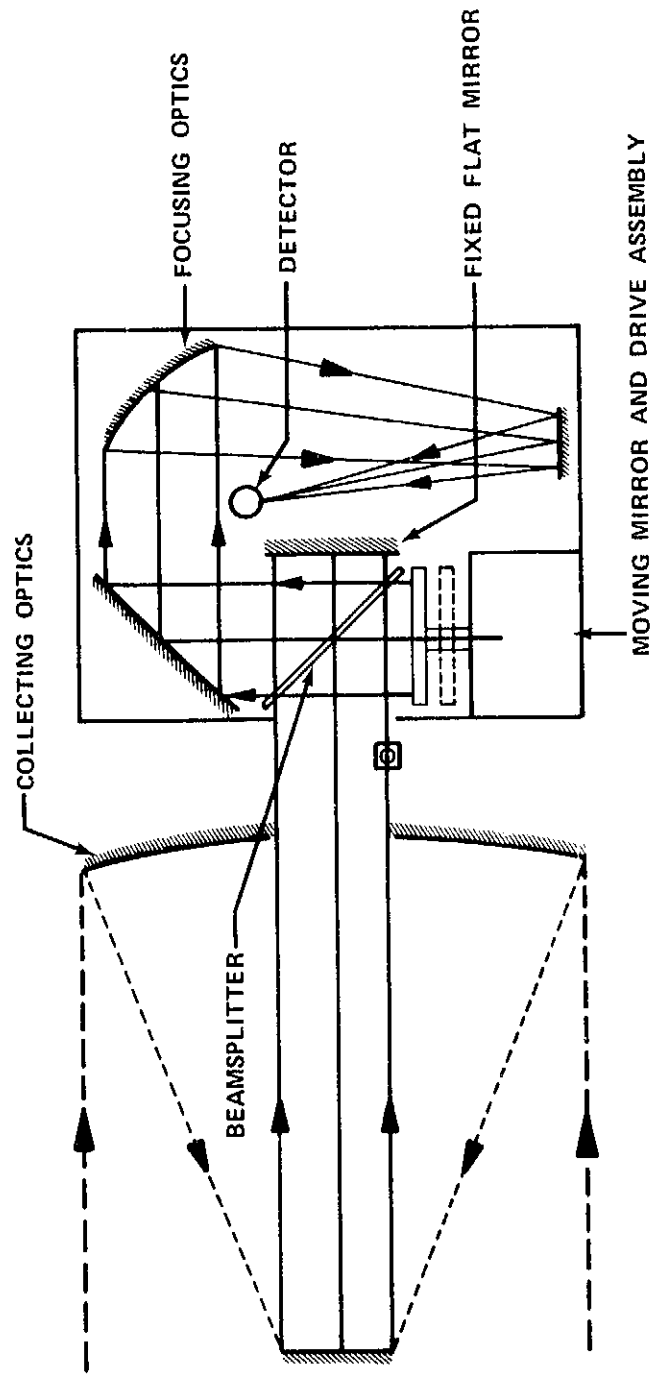

Figure 126-1. -- Infrared Interferometer (concept).

TABLE 126-1. - SPECTRAL CHARACTERISTICS

| <u>Configuration</u> | <u>Wavelength Range (μm)</u> | <u>Sensitivity ($\text{W cm}^{-2}\text{sr}^{-1}\mu\text{m}^{-1}$)</u> | <u>Signal-to- Noise Ratio</u> | <u>Dynamic Range</u> | <u>Spectral Resolution (cm^{-1})</u> | <u>Off-Axis Rejection</u> |
|----------------------|--|--|-----------------------------------|--------------------------|--|-------------------------------|
| A | 1 to 6 | 10^{-11} | 100:1 | 10^5 | 0.05 | 10^{-6} to 10^{-7} |
| B | 5 to 15 | 10^{-11} | (TBD) | 10^5 | 0.05 | 10^{-6} to 10^{-7} |
| C | 15 to 50 | 10^{-11} | (TBD) | 10^5 | 0.05 | 10^{-6} to 10^{-7} |
| D | 50 to 150 | 10^{-11} | (TBD) | 10^5 | 1.0 | 10^{-6} to 10^{-7} |

STABILIZATION AND TRACKING REQUIREMENTS

While taking data, the instrument must be stable to within 3 arc min; accuracy of tracking an area under observation must be such as to hold the pointing angle within tolerance.

TIMELINE

The interferometer can acquire data under conditions of daylight or darkness and, for operation, will be pointed in directions ranging from the nadir to the horizontal, i.e., to the limb. A maximum of three separate data takes can be scheduled during a given orbit.

CONSTRAINTS

A major constraint in the operation of the interferometer will be the presence of contaminants in the vicinity of the collecting optics, for such contamination could negate the usefulness of the instrument. A second constraint will be the requirement that the instrument be operated through all planned cycles before the supply of cryogen has been exhausted.

CHECKOUT AND TEST

BORESIGHTING REQUIREMENTS

The instrument must be boresighted to the remotely controlled platform with a maximum error of 0.1° . Additionally, the instrument must be co-aligned with the Laser Sounder (Instrument 213) and the Limb-Scanning Infrared Radiometer (Instrument 118) with a maximum error of 0.1° .

PRELAUNCH CHECKOUT

The instrument will be checked through use of test signals processed through the signal and data conversion subsystems; the output data train will be examined and analyzed for indication of anomalous conditions. The electro-mechanical operation of the scanning mirror will be verified with a GSE test set which will evaluate the rate and distance of movement of the mirror.

PREFLIGHT CALIBRATION

None.

INFLIGHT CALIBRATION

Inflight calibration will use an integral blackbody which will periodically be scanned by the instrument.

CONTROLS

Control of the interferometer will include the following facets:

- a. Power to place the instrument in standby and operate modes.
- b. Scan to control the rate and length of the scan.
- c. Integration time to be used during data take.
- d. Calibration for inflight calibration update.
- e. Cryogen to top-off the dewar instrument as required.

Pointing control will be exercised through slaving to the laser sounder and/or other instruments; separate control will not be required.

DISPLAY

The display for crew evaluation will include the following:

- a. Indication of spectral range under observation
- b. Low resolution spectrogram of observed data
- c. Status of cryogen cooling of the instrument
- d. Relative pointing angle of instrument

DATA

SCIENTIFIC

The scientific data will be comprised of 10-bit digital words recorded at the rate of 1.0 kbps. The principal product will be the output of the detectors; other items to be recorded will be the center burst, the integration time, and low-resolution spectra.

HOUSEKEEPING

In addition to spacecraft ephemeris data, housekeeping data will be generated as analog signals in eight 6-bit words, sampled at the rate of 200 bps.

Included are the following items:

- a. Relative pointing angle
- b. Scan rate and length
- c. Detector temperature and bias voltage
- d. White light interferograms (for calibration)
- e. Cryogen condition
- f. Tracking accuracy

DEVELOPMENT STATUS

FORERUNNER INSTRUMENTS

Michelson interferometers (uncooled and of very much lower resolution) have been used with considerable success in the Nimbus program. Cooled instruments are widely used in laboratories and have been used for balloon observations.

PROBLEMS

Design and Manufacturing: Among the problems will be that of achieving and maintaining the cryogenic temperature level of the internal components of the instrument; the major facet will be in the selection of materials and the fabrication of parts and components to function at the low temperatures.

A concomitant problem will be the development of a technique for storing a quantity of cryogen aboard the spacecraft for replenishment of that which is consumed during the course of the mission. The window at the entrance to the collecting optics must be selected for its transmission characteristics and for its ability to withstand the cryogenic temperature of the instrument.

Operational: Aside from protection against contamination of the entrance aperture of the collecting optics, there will be no unusual problems connected with operation of the interferometer.

LASER SOUNDER

INSTRUMENT 213

OBJECTIVE

The Laser Sounder will enable studies to be made of the composition, structure, and dynamics of the atmosphere through the backscattering and absorption of the laser beam. The instrument will operate in a radar-like mode in which the laser beam will be directed toward the atmospheric mass under observation and the receiver section will receive or otherwise measure the reflected energy. The primary area of concern will be the upper atmosphere in the nadir direction from the Orbiter.

GENERAL DESCRIPTION

LOCATION

The Laser Sounder will be mounted on a pallet.

CONFIGURATION

The Laser Sounder will be comprised of four subsystems:

- a. Laser emitter, including collimating optics
- b. Capacitor bank and power supply
- c. Receiver, including telescope, detectors, and filters
- d. Electronics

The laser emitter and the receiver will be comounted on a remotely controlled platform in the payload bay. The beam projected by the emitter will be approximately 1 mm in cross section and will diverge approximately 0.1 mrad. The laser, which will be tunable through the spectral range of 1000 to 4000 Å, will be pulsed at the rate of 1 pulse per second (pps), will have an output energy of 1 joule (J), and a pulse duration of 10 nanoseconds (ns).

The receiver telescope will be a 2-m aperture Cassegrain which will direct the incoming energy through a large dielectric filter to an array of Fabry-Perot

etalons, each approximately 2.5 cm in diameter and tunable through use of piezoelectric cells. The detectors will be photomultiplier tubes (PMT's). Developments in laser technology should extend the operating range of the instrument to 30 μm in the infrared. The photomultipliers will then be replaced by suitable infrared detectors.

In operation the laser beam will be directed toward the nadir, with the axis of the collecting optics co-aligned with the beam. During each pulse of energy from the laser, the interferometer detection system will be gated to the receiving condition at discrete periods to allow observation of the backscatter at specific altitude intervals between the Orbiter and the earth.

SPECIFICATIONS

Physical Measurements: The Laser Sounder will operate over a total spectral range of 1000 to 4000 \AA . Eventually, the operating range will be extended to cover the spectral region up to 30 μm .

Resolution:

Spatial: 1 km in range and approximately 0.005° in angular discrimination

Spectral: 0.001 \AA

Sensitivity: (TBD)

Field of View: The collecting optics field of view will be approximately 10 mrad.

Data Collection Rate: The data collection rate will be one operation per second.

Power: 115 Vac, 400 Hz at the following power levels

Laser emitter: 100 W (standby), 1 kW (operating)

Interferometer: 5 W (standby), 25 W (operating)

Electronics: 5 W (standby), 50 W (operating)

Physical Dimensions:

Size:

- a. Laser emitter/collimator - 1 x 1 x 2 m, 2 cu m
- b. Capacitor bank and power supply - 1 x 1 x 1 m, 1 cu m
- c. Receiver - 2 m diam x 1 m, 3.1 cu m
- d. Electronics - 0.2 x 0.2 x 0.2 m, 0.01 cu m

Weight:

- a. Laser emitter/collimator - 100 kg
- b. Capacitor bank and power supply - 250 kg
- c. Receiver - 50 kg
- d. Electronics - 15 kg

Other:

Laser:

- a. Peak power - 100 MW
- b. Pulse rate - 1 pps
- c. Pulse duration - approximately 10 ns
- d. Efficiency - 0.1 percent

Receiver:

- a. Telescope - 2 m diam, optical quality not critical
- b. Dielectric filter - approximately 30 cm diam, 100 Å bandpass
- c. Etalons - 2.5 cm diam, piezoelectric scanning, less than or equal to 1.0 Å bandpass, finesse (TBD), high etendu.
- d. Blocking filters - (TBD) diam, 5 Å bandpass
- e. Detectors - Photomultiplier tubes, type (TBD)

Cooling aspects: Provisions must be incorporated to dissipate the heat generated in the laser head during operation.

OPERATION

POINTING REQUIREMENTS

The pointing error must be less than 1° .

STABILIZATION AND TRACKING REQUIREMENTS

The stabilization error must not exceed (TBD) arc minutes.

TIMELINE

The Laser Sounder will be operated until complete global coverage has been obtained.

CONSTRAINTS

A major constraint will be that imposed by the heat generated by the laser head; rapid dissipation will be necessary.

CHECKOUT AND TEST

BORESIGHTING

The Laser Sounder must be co-aligned with the associated interferometer within 0.1° .

PRELAUNCH CHECKOUT

The foremost item requiring prelaunch checkout will be the operation of the laser. Through use of suitable GSE, the output emission characteristics of the laser will be measured and verified for conformance to specifications.

PREFLIGHT CALIBRATION

The output emission characteristics of the laser and the detection characteristics of the receiver will be measured, using suitable GSE. The

measurements will be taken across the entire spectral operating range of the instrument and will include all tuning ranges and features of the instrument. The measurements thus derived will form baseline calibration data for the instrument.

INFLIGHT CALIBRATION

The need for inflight calibration and the means through which such calibration will be accomplished require continuing study.

CONTROLS

Control of the Laser Sounder will include the following facets:

- a. Power to place the instrument in standby and operate modes.
- b. Laser tune to tune the wavelength of the emitted laser beam.

Pointing control will be exercised through maneuvering of the remotely controlled stabilized platform; separate control will not be required.

DISPLAYS

The display for crew evaluation will include:

- a. Indication of the relative pointing angle of the instrument.
- b. Indication of the wavelength of the laser output, with an alarm and advisory indication of variances from the selected setting.
- c. Indication of the pulse duration, with a caution and warning indication of variance from the required value.
- d. Indication of the temperature of the laser head, with a caution and warning indication of an overheat condition.

DATA

SCIENTIFIC

Each of the 10 detector channels will generate two 16-bit words per data point during a data take period; an average of 50 data points will be taken. The digital data will be generated at the rate of 16 kbps.

HOUSEKEEPING

In addition to Orbiter ephemeris data, the following items of housekeeping data will be required; the data will be generated digitally, with 10-bit word lengths, at the rate of 1 kbps:

- a. Emitted pulse width
- b. Emitted pulse power
- c. Wavelength setting
- d. Laser head temperature
- e. Co-alignment errors

DEVELOPMENT STATUS

FORERUNNER INSTRUMENTS

There are no forerunner instruments with the capabilities described herein.

PROBLEMS

Design and Manufacturing: Techniques for tuning lasers over the full bandwidth required have not been developed. Attaining energy levels approaching 1 joule per pulse in the UV region will require major advances in laser technology.

Operational: The laser is a significant EMI generator each time it is pulsed. Therefore, its use in conjunction with EMI susceptible instruments must be carefully timed.

Similar concern for timelining must be exercised due to the very large amount of electrical power required to produce each pulse.

The combination of desired power levels, pulse widths and repetition rates may provide a significant eye safety hazard to ground personnel at some wavelengths.

ELECTRON ACCELERATOR

INSTRUMENT 303

OBJECTIVE

The Electron Accelerator will be used to study the excitation of neutral components of the upper atmosphere and of plasma components in the ionosphere. It will also be used (1) to map magnetic field lines of the earth, (2) to study the injection of trapped electrons in the earth's radiation belts, (3) to determine the magnitude and direction of the electric field in the ionosphere, and (4) to study the excitation of plasma waves in the ionosphere.

GENERAL DESCRIPTION

LOCATION

This instrument will be mounted on a pallet.

CONFIGURATION

The Electron Accelerator will be a modular subsystem of the AMPS Particle Accelerator System (see E of figure 303-1). In this system, Orbiter 28 Vdc power will be converted to 500 V by subsystem A, and the 500 V will be utilized to charge a capacitor bank (subsystem B). Power from the bank will be further converted to 30 kV (maximum) by subsystem C. The output of this supply will establish the accelerating voltage for the Electron Accelerator. The accelerator will be in the form of a filament heated cathode electron source followed by a control grid, an acceleration region, diverging and converging lens electrodes, and final accelerating electrode. The beam will emerge into a magnetic field region supplied by two orthogonal sets of coils to provide steering and/or scanning. The accelerator and its power supplies will be pallet mounted. The Electron Accelerator will be used in conjunction with an assortment of particle detectors, electromagnetic wave receivers, ion probes, television, and spectroradiometric instruments both for diagnostics of the beam characteristics in the vicinity of the accelerator and for the sensing of remote phenomena generated by the electron beam.

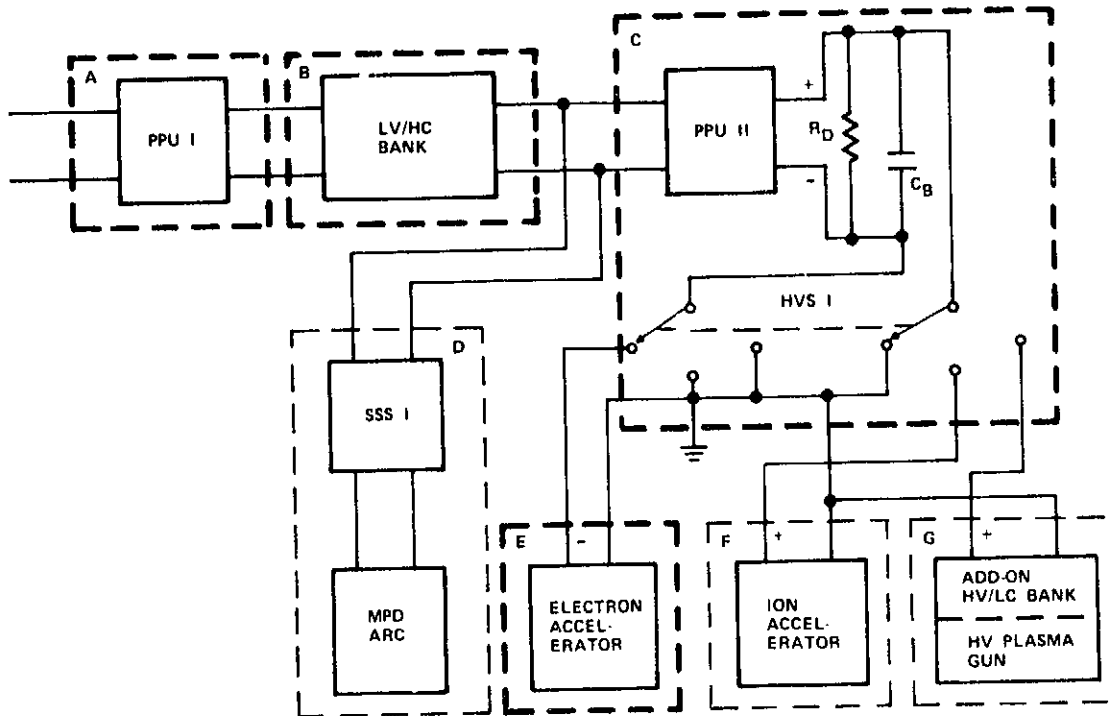

SUBSYSTEM

ELEMENTS

- | | |
|---|---|
| A | POWER PROCESSING UNIT (PPU) I (28V/400A/ /500V/23A) |
| B | LOW VOLTAGE/HIGH CAPACITANCE (LV/HC) BANK (500V/0.8F) |
| C | PPU II (500V/400A/ /30,000V/10A), DRAINAGE RESISTOR (R_D), BUFFER CAPACITOR (C_B), HIGH VOLTAGE SWITCH (HVS) I |
| D | SOLID STATE SWITCH (SSS) I, MAGNETOPLASMA DYNAMIC (MPD) ARC (500V/200,000A) |
| E | ELECTRON ACCELERATOR (30,000V/7A) |
| F | ION ACCELERATOR (20,000V/10A) |
| G | ADD-ON HIGH VOLTAGE/LOW CAPACITANCE (HV/LC) BANK, HIGH VOLTAGE (HV) PLASMA GUN |

Figure 303-1. — AMPS Particle Accelerator System.

**ORIGINAL PAGE IS
OF POOR QUALITY**

SPECIFICATIONS

Beam Energy: 1 to 30 keV

Beam Energy Spread ($\Delta E/E$): less than or equal to 0.1

Beam Current: 0 to 7 A

Operating Modes:

- a. Direct current (dc)
- b. Pulsed — repetition rate and pulse duration variable within 0.05 duty cycle at maximum power
- c. Modulated — amplitude 0 to 100 percent, frequency 0 to 10 MHz with 0.05 duty cycle at maximum power

Beam Angular Divergence: $\pm 5^\circ$ maximum

Pitch Angle Variability: 0° to 180° (magnetic deflection plus vehicle orientation)

Power Input:

Voltage: 28 Vdc

Standby power: 400 W

Average power: 5 kW

Maximum power: 10 kW

Planned energy consumption: 40 kWh/day (maximum)

Energy storage for high intensity pulses will be accomplished by means of a 10^5 J, 0.8 F, 500 V capacitor bank.

Physical Dimensions: The Electron Accelerator and its associated driving system are shown in figures 303-2, 303-3, and 303-4.

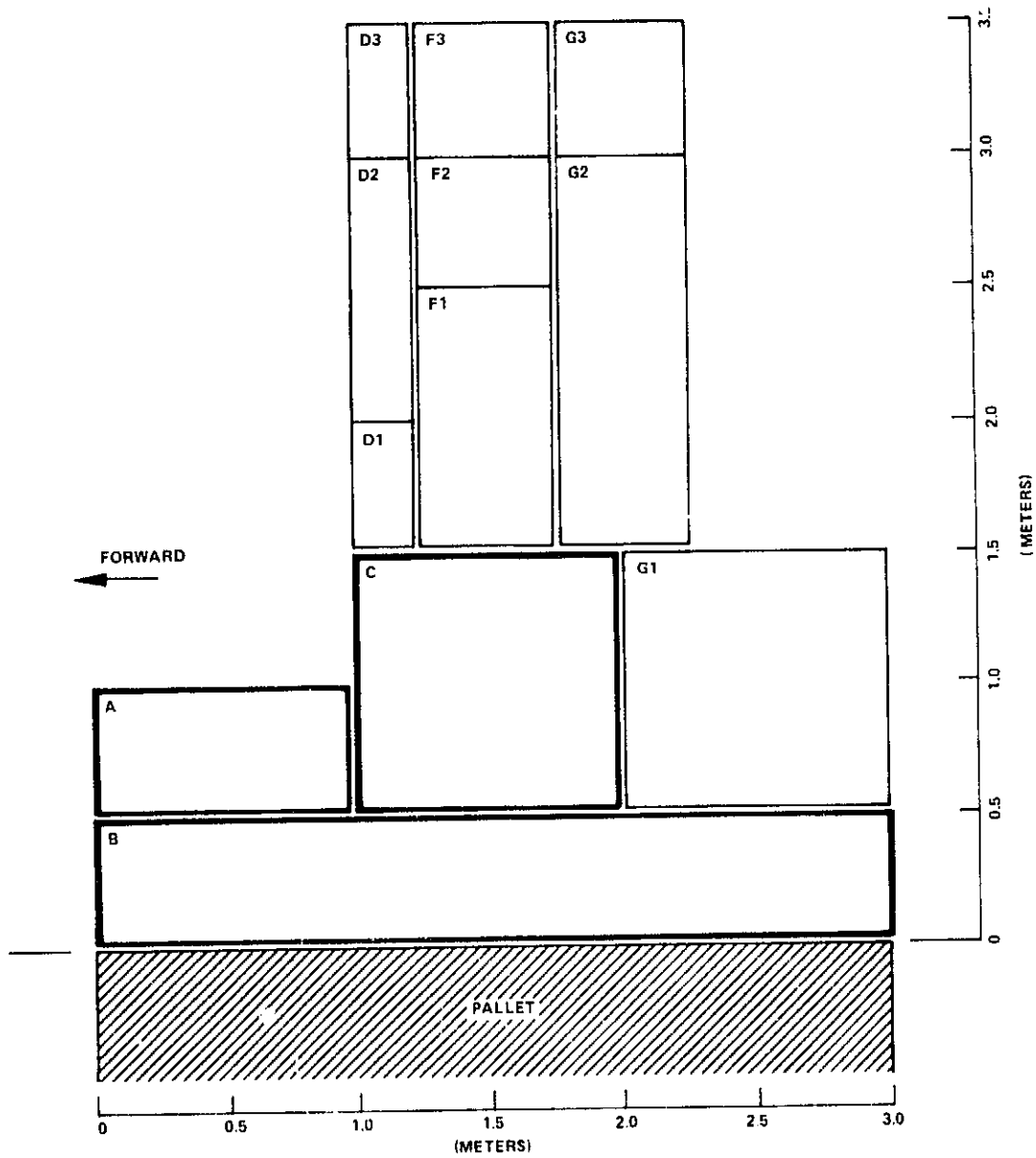

Figure 303-2. — AMPS Particle Accelerator System Y-axis view looking starboard.

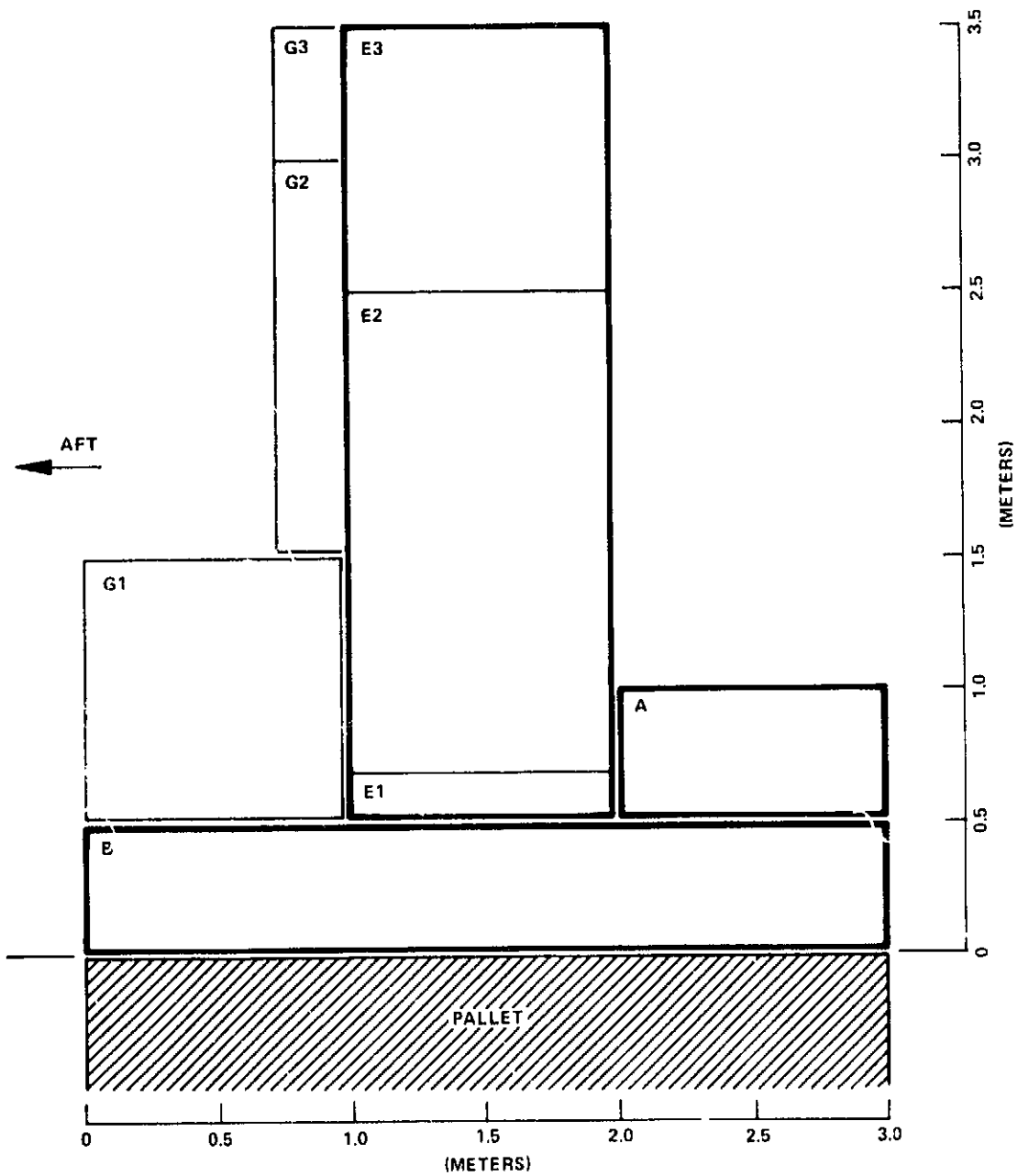

Figure 303-3. — AMPS Particle Accelerator System Y-axis view looking port.

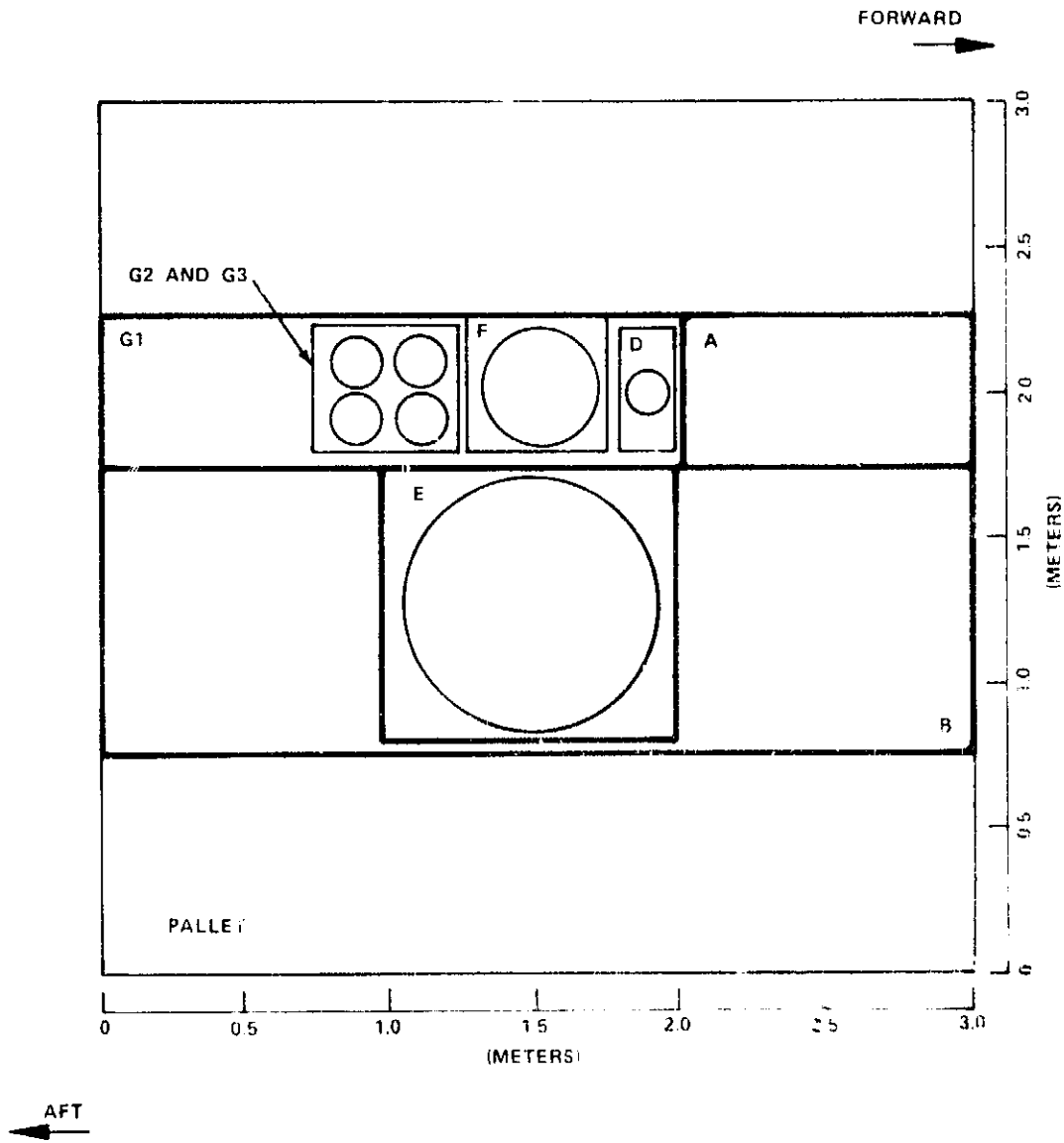

Figure 303-4. -- AMPS Particle Accelerator System Z-axis view locking down

| <u>System</u> | <u>Dimensions (meters)</u> | <u>Volume (cu m)</u> | <u>Weight (kg)</u> |
|---------------------------------------|--------------------------------|--------------------------|------------------------|
| *Power unit (A) | 0.5 x 1.0 x 0.5 | 0.25 | 45 |
| *Capacitors (B) | 0.5 x 3.0 x 1.5 | 2.25 | 540 |
| *Power unit (C) | 1.0 x 1.0 x 0.5 | 0.5 | 110 |
| Electron Accelerator (E1, E2, E3) | 3.0 x 1.0 x 1.0 | 3.0 | 40.5 |
| **Pulse program box (E ^d) | -- | 0.1 | 4.5 |

*If the Ion Accelerator (Instrument 301), Magnetoplasmadynamic (MPD) Arc (Instrument 304), and the High Voltage Plasma Gun (Instrument 306) are also flown, they will share some of the same subsystems. See figure 303-1 and instrument descriptions 301, 304 and 306 for additional details.

**The pulse program box will be located on the operator's console.

OPERATION

POINTING REQUIREMENTS

The accuracy of pointing the axis of the Electron Accelerator should be within $\pm 6^\circ$.

STABILIZATION

The Orbiter stability should be within 1 deg/sec or less.

ORBITER ATTITUDE

The attitude of the Orbiter should be known to within 1 .

TIMELINE OF OPERATION

The Electron Accelerator will operate for a maximum of 4 hr/day. Standby operation would occur only during this 4-hr period.

CONSTRAINTS

Operation of the accelerator should take place in the ionosphere at a minimum of 200-km altitude. Pointing of the electron beam with respect to the direction of the ambient magnetic field may not be arbitrary because of the

possibility of beam return and collision with the Orbiter caused by the gyromotion of the beam particles in the field. Thermal, X-radiation, and vehicle charging problems might be created depending upon return beam energy and intensity. Details of possible pointing constraints are TBD. However, the firing of the electron accelerator should be restricted by a GO/NO GO command generated by a magnetometer, namely, the Triaxial Fluxgate (Instrument 536) which will also be on the Orbiter.

CHECKOUT AND TEST

BORESIGHTING REQUIREMENTS

Because the pointing accuracy is $\pm 6^\circ$, only a mechanical alignment should be necessary.

PRELAUNCH CHECKOUT

Low voltage subsystems will be activated and housekeeping parameters observed. Production of accelerated electrons will not be possible as a vacuum environment will be required for this operation.

PREFLIGHT CALIBRATION

None.

INFLIGHT CALIBRATION

Inflight calibration will be performed only if some or all of the AMPS Particle Accelerator Beam Diagnostics Group (Instruments 549, 550, and 551) are also flown. The frequency and duration of calibration are TBD. The calibrations will probably encompass a measurement of beam energy, intensity, and a two-dimensional profile.

CONTROLS

The Electron Accelerator will be controlled from a console in the Orbiter aft crew station. The accelerator design will require approximately

12 control functions transmitted to the pallet mounted subsystems for operational control. Included in these will be the following:

| <u>Subsystem</u> | <u>Controlled Parameters</u> |
|------------------|--|
| A | Capacitor bank charge current |
| C | High voltage switch (HVS 1) (four positions) |
| C | Power processing unit I (PPU I) output voltage |
| C | Power processing unit I (PPU I) output current I |
| E | Control grid voltage |
| E | Control grid frequency |
| E | Cathode heater |
| E | Diverging lens voltage |
| E | Converging lens voltage |
| E | X-Z sweep coil voltage |
| E | Y-Z sweep coil voltage |
| - | Control console power on/off |

Details of implementing these controls are TBD. However, the design will probably require analog control lines from the console to the accelerator subsystems capable of supporting signal bandwidths up to 10 MHz. Several of the control functions will need rapid time sequencing. This will be accomplished by a programmable pulse program box located on the operator's console. Design details of the box are TBD.

DISPLAYS

Approximately 10 to 20 parameters relating to accelerator operation will require displays. Some will be slowly varying, while others can occur with repetition rates up to 10 MHz or can be transient (one-shot) pulses with widths as short as 100 ns. It will be necessary to view the pulse shapes of a number of the rapidly varying parameters correlated in time. In addition, some of these pulse shapes need to be permanently stored as scientific data. Probably the best way to accomplish display will be with several fast digitizers with selectable sampling frequency up to 100 MHz and storage of

the digitized pulse shapes in memories for immediate recall to a CRT display. The parameters which will require pulse shape display are:

| <u>System</u> | <u>Parameter</u> |
|---------------|-----------------------|
| C | PPU II output voltage |
| C | PPU II output current |
| E | Accelerated current |
| E | Acceleration voltage |
| E | Grid current |

In addition to these parameters, all operational and housekeeping parameters should be sampled at a lower rate and displayed, probably on a CRT with commandable digital format. It is estimated that there will be 10 to 20 such parameters.

DATA

SCIENTIFIC

The Electron Accelerator will generate slowly varying, modulated (up to 10 MHz) and pulsed (as fast as 100 ns width) parameters. Scientific data storage will require retaining the pulse shapes of several of the pulse parameters or sampling several cycles of the modulated parameters and storage of the shapes of the parameters. For the rapidly varying parameters, probably the best way to handle the data will be with fast digitizers with selectable sampling rates to 100 MHz and storage of the digitized parameters' associated memories (already mentioned in Display paragraph), before merging into the Orbiter systems. There will be two such accelerator scientific parameters. They are as follows:

| <u>Subsystem</u> | <u>Parameter</u> | <u>Bandwidth (MHz)</u> | <u>Bit Rate (kbps)</u> |
|------------------|----------------------|----------------------------|----------------------------|
| E | Accelerated current | 10 | 2.5 |
| E | Acceleration voltage | 1 | 2.5 |

HOUSEKEEPING

Time varying and dc parameters will be stored and merged with the scientific data. The peak or average values of the time varying parameters will be stored. At the present time, it is estimated that there will be 15 to 20 of these parameters which should be sampled at 0.1 sps, digitized to 8-bits for a total rate of approximately 16 bps.

DEVELOPMENT STATUS

FORERUNNER INSTRUMENTS

Electron accelerators up to 40 keV energy but with fractional ampere current outputs have flown on several rockets with successful results.

PROBLEMS

Design and Manufacturing: Most of the subsystems should be within the state-of-the-art. However, design and development effort may be required for the capacitor bank.

Operational: Corona and high voltage discharge problems will be possible, particularly in the presence of gas releases. In addition, beam instabilities caused by the ambient plasma in the vicinity of the Orbiter may occur. Although the Gas Plume Release (see Instrument 549) is envisioned as a method for vehicle neutralization, some study and testing will be required to determine its adequacy.

MAGNETOPLASMA DYNAMIC (MPD) ARC

----- INSTRUMENT 304

OBJECTIVE

The capabilities of the MPD Arc will include the following: (1) the excitation of neutral and plasma components in the upper atmosphere and the ionosphere, (2) the tracing and mapping of the magnetic field lines of the earth, (3) the modification of the conductivity in certain regions of the earth's ionosphere, and (4) the generation of plasma waves and disturbances in the very low frequency/extreme low frequency (VLF/ELF) regions.

GENERAL DESCRIPTION

LOCATION

This instrument will be mounted on the pallet.

CONFIGURATION

The MPD Arc will be a subsystem of the AMPS Particle Accelerator System. (See D of figure 304-1.) In this system, Orbiter power will be converted to 500 Vdc by subsystem A and will charge a capacitor bank (subsystem B). Gas will be admitted to the MPD, and when a predetermined pressure is reached, the solid state switch (SSS I) of subsystem D will apply the output of the capacitor bank to the cathode of the MPD. A high intensity discharge will result during which a plasma of ions and electrons will be ejected from the discharge region.

The MPD Arc will operate with a variety of instrumentation including its own beam diagnostic package (TBD) and also mass spectrometers, medium energy ion mass analyzers, spectroradiometric instruments, television, and wave receivers.

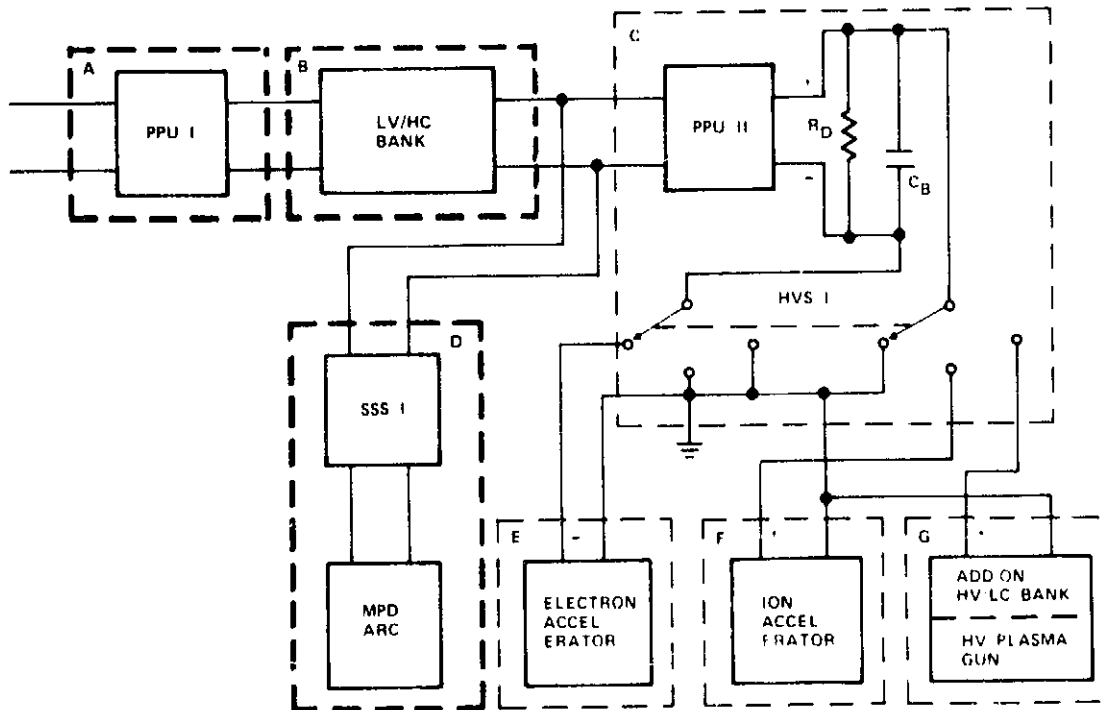

| SUBSYSTEM | ELEMENTS |
|-----------|---|
| A | POWER PROCESSING UNIT (PPU) I (28V 400A 500V 23A) |
| B | LOW VOLTAGE HIGH CAPACITANCE (LV/HC) BANK (500V-0.8F) |
| C | PPU II (500V 400A 30,000V 10A); DRAINAGE RESISTOR (R _D); BUFFER CAPACITOR (C _B); HIGH VOLTAGE SWITCH (HVS) I |
| D | SOLID STATE SWITCH (SSS) I; MAGNETOPLASMA DYNAMIC (MPD) ARC (500V 200,000A) |
| E | ELECTRON ACCELERATOR (30,000V 7A) |
| F | ION ACCELERATOR (20,000V 10A) |
| G | ADD ON HIGH VOLTAGE LOW CAPACITANCE (HV LC) BANK HIGH VOLTAGE (HV) PLASMA GUN |

Figure 304-1. — AMPS Particle Accelerator System.

ORIGINAL PAGE IS
OF POOR QUALITY

SPECIFICATIONS

Voltage (Plasma): 100 to 500 V

Energy Spread ($\Delta E/E$): 0.5 maximum

Current Output: 1000 to 200,000 A

Operating Mode (Pulsed): Pulse length will be determined by the capacitance and voltage of subsystem B and by the arc voltage and current.

Repetition Rate: determined by maximum allowable Orbiter power drain

Beam Angular Spread: $\pm 20^\circ$ maximum

Pitch Angle Variation: 0° to 180° (by vehicle orientation)

Gas (Plasma) Species: A wide range of laboratory gas can be utilized.

Power Input:

Voltage: 28 Vdc

Standby power: 50 W

Average power: 5 kW

Maximum power: 10 kW

Energy storage for high intensity bursts will be achieved by a 10^5 J, 0.8 F, 500 V capacitor bank.

Physical Dimensions: The MPD Arc and its associated subsystems are shown in figures 304-2, 304-3, and 304-4.

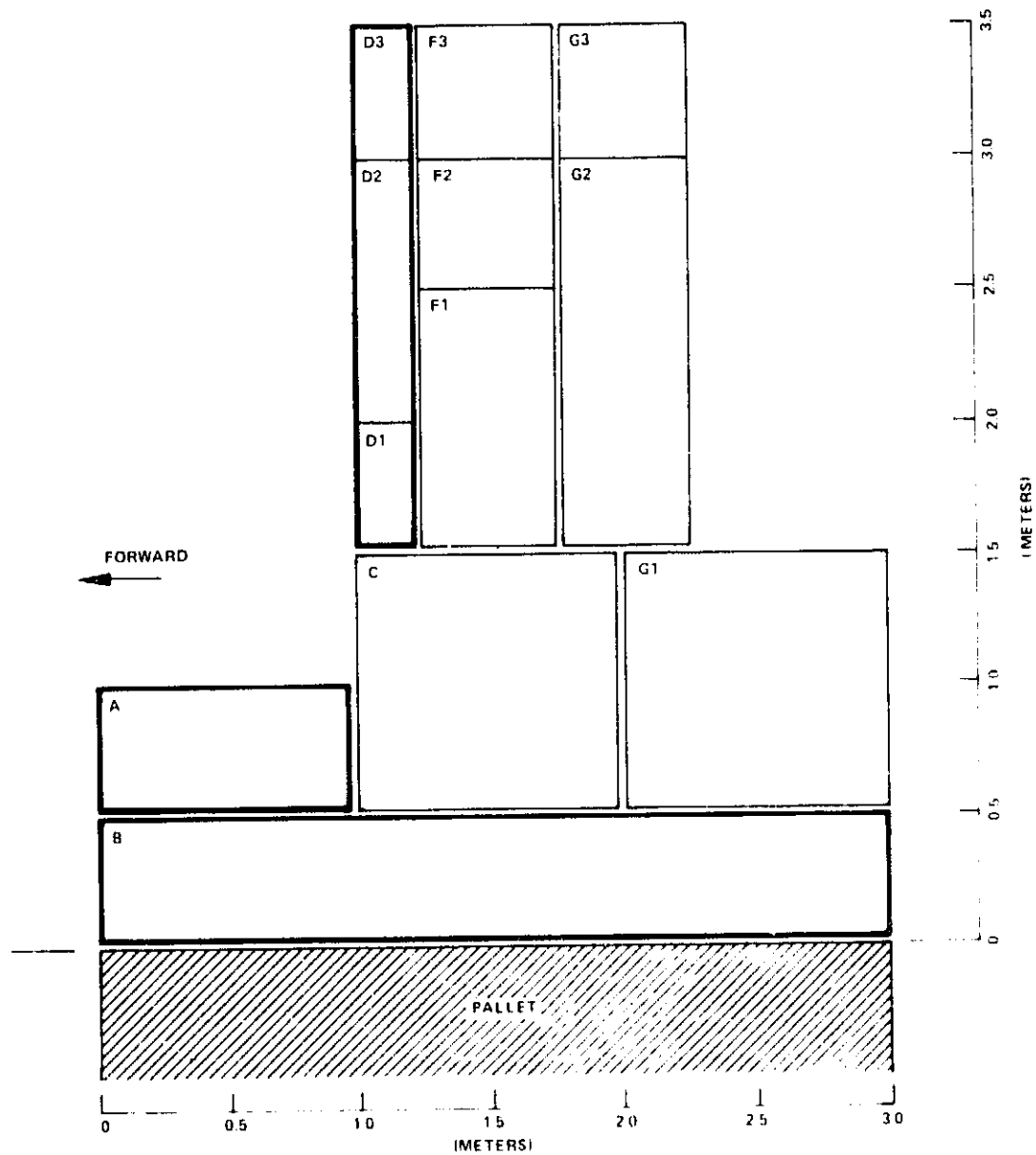

Figure 304-2. - AMPS Particle Accelerator System Y-axis view looking starboard.

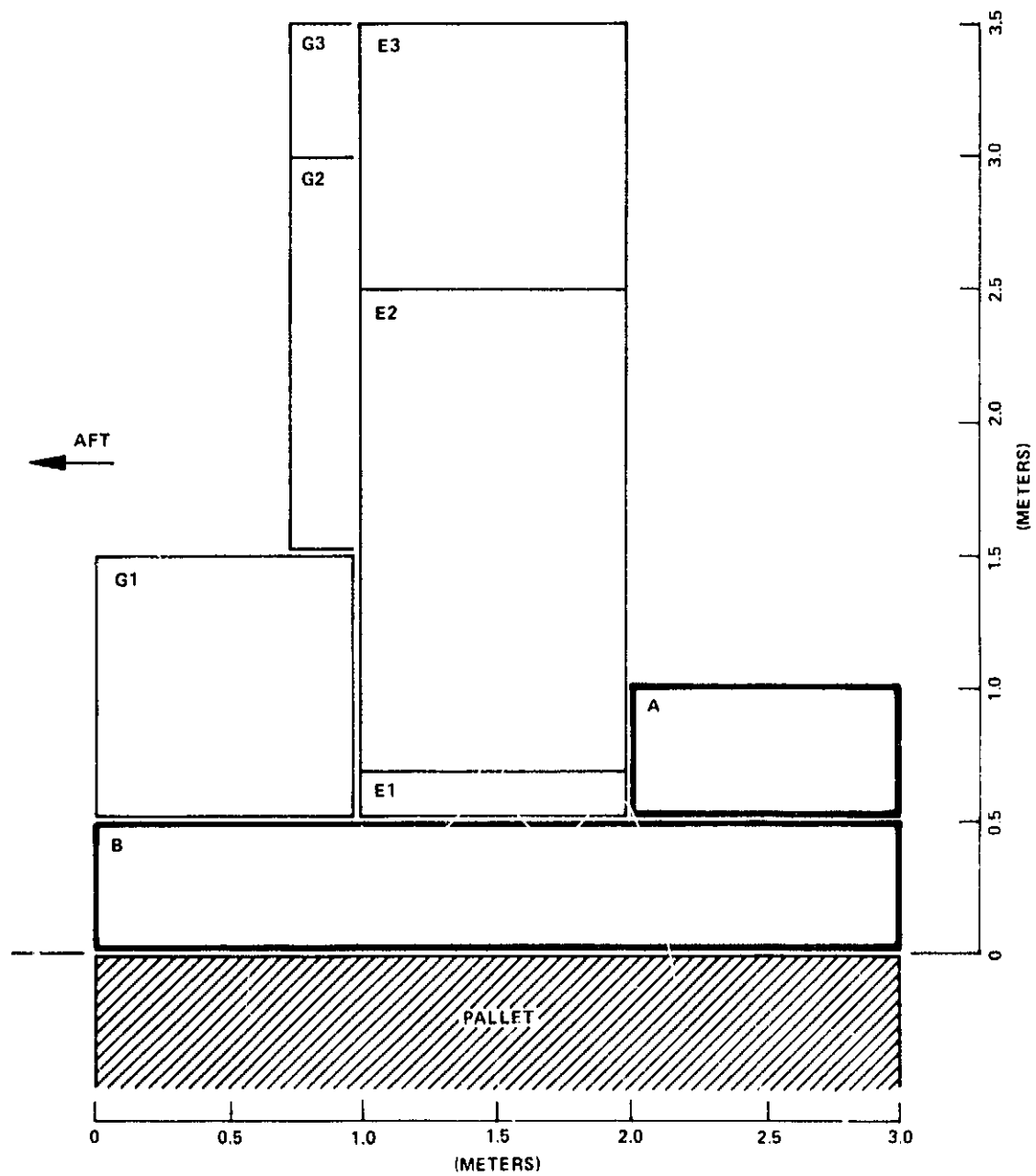

Figure 304-3. — AMPS Particle Accelerator System Y-axis view looking port.

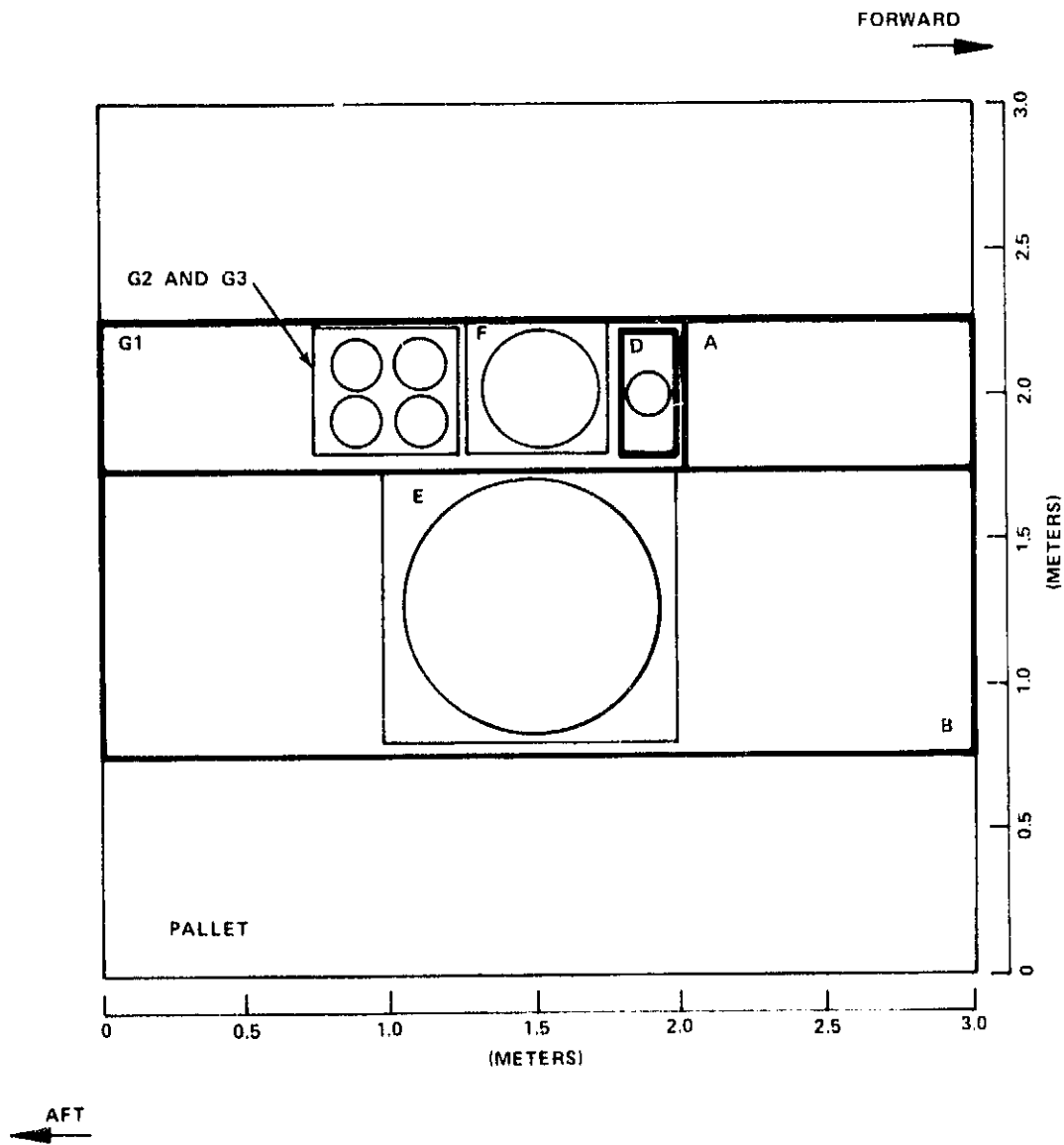

Figure 304-4. — AMPS Particle Accelerator System Z-axis view looking down.

| <u>Subsystem</u> | <u>Dimensions (meters)</u> | <u>Volume (cu m)</u> | <u>Weight (kg)</u> |
|--------------------------|--------------------------------|--------------------------|------------------------|
| *Power unit (A) | 0.5 x 1.0 x 0.5 | 0.25 | 45 |
| *Capacitors (B) | 0.5 x 3.0 x 1.5 | 2.25 | 540 |
| MPD Arc (D1, D2, D3) | 2.0 x 0.25 x 0.5 | 0.25 | 40.5 |
| **Pulse program box (D4) | — | 0.02 | 4.5 |

*If the Ion Accelerator (Instrument 301), Electron Accelerator (Instrument 303), and the High Voltage Plasma Gun (Instrument 306) are also flown, they will share some of the same subsystems. See figure 304-1 and instrument descriptions 301, 303, and 306.

**The pulse program box will be located on the operator's console.

OPERATION

POINTING REQUIREMENTS

The accuracy of pointing the MPD Arc beam axis should be within $\pm 2^\circ$.

STABILIZATION

The allowable rate of angular change of pointing should be 1 deg/sec or less.

ORBITER ATTITUDE

The Orbiter attitude should be known to within $\pm 2^\circ$.

TIMELINE OF OPERATION

The MPD Arc will be operated for approximately 4 hr/day, depending upon available Orbiter power and thermal dissipation constraints.

CONSTRAINTS

The MPD Arc will operate at a minimum altitude of 200 km. Pointing of the plasma beam with respect to the direction of the ambient magnetic field may not be arbitrary because of the possibility of beam return and collision with the Orbiter caused by the gyromotion of the beam particles in the field. Thermal and charging problems may be created depending upon return beam

energy and intensity. Details of possible pointing constraints are TBD. However, the firing of the MPD Arc should be restricted by a GO/NO GO command generated by a magnetometer, namely, the Triaxial Fluxgate (Instrument 536) which will also be on the Orbiter.

CHECKOUT AND TEST

BORESIGHTING REQUIREMENTS

These will be only as required to meet the specified $\pm 2^\circ$ pointing accuracy.

PRELAUNCH CHECKOUT

The low voltage systems will be activated and housekeeping parameters checked. A typical pulse sequence should be initiated except that high voltage will probably not be applied to the cathode at atmospheric pressure. A GSE gas system will probably be required to service the gas storage bottles of the MPD Arc system.

PREFLIGHT CALIBRATION

None.

INFLIGHT CALIBRATION

Inflight calibration will probably occur; however, the instrumentation for performing it is TBD.

CONTROLS

The MPD Arc will be controlled from a console in the Orbiter aft crew station. The arc design will require three control functions transmitted to the pallet mounted subsystems. These are:

| <u>Subsystem</u> | <u>Controlled Parameters</u> |
|------------------|-------------------------------|
| A | Capacitor bank charge current |
| D | MPD Arc plenum pressure |
| D | Solid state switch (SSS I) |
| - | Control power on/off |

Details of implementing the time sequencing and the voltage level of these controls are TBD, but the design will probably require control lines from the accelerator console directly to the pallet MPD Arc subsystems, i.e., not transmitted through the remote acquisition units (RAU).

DISPLAYS

Proper control of the accelerator will require the display of the pulse waveforms of two analog transient pulses as well as the peak or average (digital) values of several dc or slowly varying housekeeping parameters. The waveforms will have bandwidths to 1 MHz and should be digitized with fast analog to digital converters with selectable sampling frequencies to 10 MHz and with associated memories for recall to a CRT display. The slowly varying parameters should be displayed digitally on a CRT. It is estimated that there will be 10 to 15 of these parameters.

DATA

SCIENTIFIC

The scientific data will consist of the pulse waveforms of two parameters rapidly digitized (non-RAU) to 8-bit words. The parameters will be:

| <u>Subsystem</u> | <u>Parameter</u> | <u>Bandwidth (MHz)</u> | <u>Bit Rate (kbps)</u> |
|------------------|-------------------|----------------------------|----------------------------|
| D | Discharge current | 1 | 0.5 |
| D | Discharge voltage | 1 | 0.5 |

HOUSEKEEPING

There will be 10 to 15 housekeeping parameters whose peak or average values must be sampled. These will be sampled at 0.1 sps digitized to 8-bits for a total rate of approximately 16 bps.

DEVELOPMENT STATUS

FORERUNNER INSTRUMENTS

Plasma accelerators with the capabilities of the present accelerator exist as ground based laboratory instruments. A plasma accelerator of somewhat higher voltage but of significantly lower output intensity has flown on at least one unmanned rocket.

PROBLEMS

Design and Manufacturing: Some design effort will be required for the capacitor storage bank for the system.

Operational: The possibility of beam instabilities exists because of beam interaction with ambient plasma in the vicinity of the Orbiter.

GAS RELEASE MODULE

----- INSTRUMENT 532

OBJECTIVE

This instrument will be used:

- a. to study the photoexcitation and photoionization of gas molecules of various species by solar irradiation,
- b. to study the decay of excited species and reactions of radicals and ions, and
- c. to measure solar excitation rates for continuous processes (e.g., photoionization) and discrete processes (e.g., resonance fluorescence).

GENERAL DESCRIPTION

LOCATION

This instrument will be mounted on a pointing system on a pallet.

CONFIGURATION

This instrument will consist of five principal subsystems as follows:

- a. Gas handling system
- b. Excitation chamber
- c. Monochromator
- d. Ion mass spectrometer
- e. Electronics box

Gases will be admitted through the gas handling system to the excitation chamber to a known pressure and exposed to the total unattenuated solar flux. The excited species formed by solar excitation will be observed with a concave grating monochromator. Ions produced in the excitation chamber will be analyzed by the mass spectrometer, which will be in the form of a quadrupole mass filter, and collected by an electron multiplier. Metastable excited

states will be studied by the release of gas to space to eliminate wall effects. For this operation, only the monochromator will be utilized for analysis. The instrument will also allow use of the gas release mode only (i.e., subsystems 1 and 5) for observations by other Orbiter instrumentation. During times when gas releases are precluded, the monochromator will be pointed and utilized for atmospheric phenomena observations. The electronics box will electrically interface the preceding four subsystems with the Orbiter systems. Measurements of the wide wavelength range to be covered (0.03 to 1.2 μm) will be accomplished by utilizing three distinct monochromators, which will have the same electrical and mechanical interfaces such that a particular one can be easily attached to the system before launch. Additional details are presented in figure 532-1.

SPECIFICATIONS

Gas Species: a wide range of laboratory gases (four species per flight)

Wavelength Range (Monochromator): initially 1100 to 4500 \AA , growth modes include monochromators with ranges of 300 to 1500 \AA and 4000 \AA to 1.2 μm

Mass Range (Mass Filter): 1 amu to approximately 100 amu

Wavelength Resolution (Monochromator): 0.2 \AA @ 1200 \AA (initially)

Mass Resolution (Mass Filter): at worst 1 amu

Sensitivity: (TBD)

Field of View: approximately 2 to 3°

Data Collection Rate: (TBD)

Power: All subsystems will be powered through the electronics box. Voltage input will be 28 Vdc. Power distribution for the subsystems will be 10 W, gas system; 100 W, mass filter; and 30 W, monochromator, for a total of 140 W.

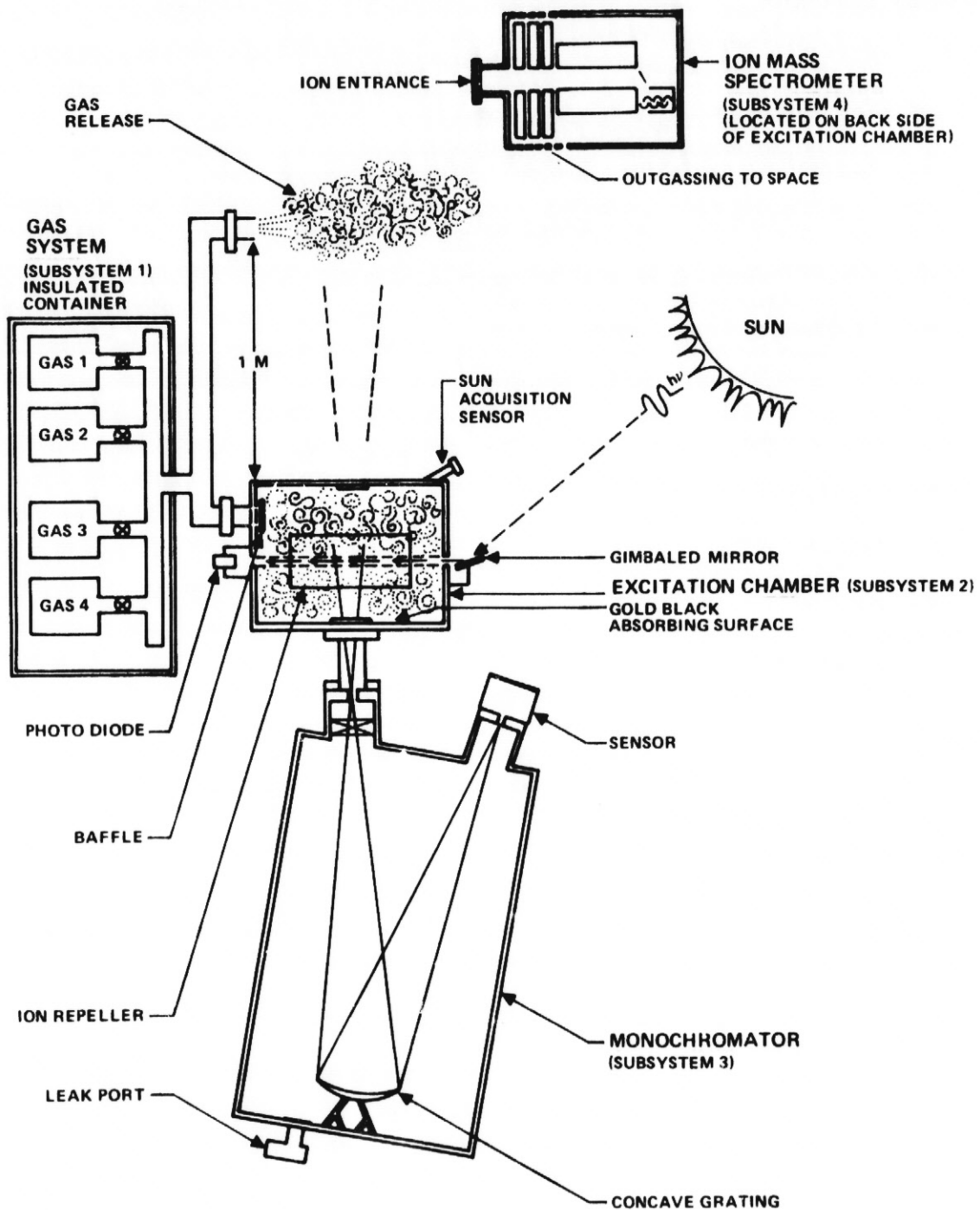

Figure 532-1. -- Instrumentation for measurement of solar photoexcitation and photoionization rates.

ORIGINAL PAGE IS
OF POOR QUALITY

Physical Dimensions:

Size:

- a. Gas system — 1 x 0.5 x 0.25 m
- b. Excitation chamber — 0.5 x 0.25 x 0.125 m
- c. Monochromator — 1.75 x 1.0 x 0.5 m
- d. Mass filter — 0.75 m x 0.5 m diam
- e. Electronics box — 0.30 x 0.30 x 0.30 m

Weight:

- a. Gas system — 23 kg
- b. Excitation chamber — 2.3 kg
- c. Monochromator — 11.4 kg
- d. Mass filter — 9.1 kg
- e. Electronics box — 3 kg

OPERATION

POINTING REQUIREMENTS

For experiments which utilize the excitation chamber, the instrument should be pointed with an accuracy of 2° . This will allow a sun sensor on the excitation chamber to acquire the sun and to control a gimbaled plane mirror which will reflect the sunlight into the entrance aperture of the chamber. Use of the monochromator for atmospheric observations will require a pointing accuracy of 1° .

STABILIZATION

The allowable Orbiter rate should be 0.15 deg/sec or less in either mode of operation.

ORBITER ATTITUDE KNOWLEDGE

The attitude of the Orbiter should be known to within $\pm 1^\circ$.

TIMELINE OF DATA TAKES

Gas release data can be taken whenever the instrument is in sunlight.

CONSTRAINTS

The gas system temperature should be confined to the temperature range +5° to +35° C.

CHECKOUT AND TEST

BORESIGHTING REQUIREMENTS

These are only as required in order to achieve the 1° pointing accuracy.

PRELAUNCH CHECKOUT

The low voltage systems should be activated and housekeeping parameters measured. Individual gas bottle valves should be cycled. Pulses should be fed into the inputs of the electron multipliers' or photomultipliers' analog electronics to check proper operation. Microprocessing will probably be incorporated into the instrument to ease interfacing with ground support equipment and the Orbiter systems. Gas filling equipment will be required to service the gas release system.

PREFLIGHT CALIBRATION

Prelaunch calibration is TBD. There exists the possibility of calibrating the monochromator (at least in the wavelength range serviced by a photomultiplier) by means of a calibrated light source. The mass filter cannot be activated and hence cannot be calibrated at atmospheric pressure.

INFLIGHT CALIBRATION

The mass filter will essentially be self-calibrating insofar as mass determination is concerned by virtue of knowing the gas species supplied (i.e., the predominant mass peak should be a singly charged molecule of the gas species released into the excitation chamber). Intensity calibration (i.e., sensitivity) of the electron multiplier will not be performed inflight.

The monochromator may be calibrated by using a Penray light source attached to the system. Calibrations will be performed at least twice per flight, at the beginning of instrument operations and at the conclusion of all instrument operations.

CONTROLS

The following commands will be required for instrument control:

- a. Gas bottle select - 4-bit command
- b. Gas pressure regulate - 16-bits (two sequential 8-bit words)
- c. Gas mode - 2-bit command
- d. Grating control - two sequential 8-bit words
- e. Mas filter control - two sequential 8-bit words
- f. Low voltage on/off - discrete command

DISPLAYS

A CRT display with two or three callable formats will be required for the following parameters:

- a. Bottle number
- b. Gas mode
- c. Gas system pressure
- d. Chamber pressure
- e. Chamber photodiode signal
- f. Chamber temperature
- g. Monochromator intensity versus wavelength (analog display)
- h. Mass filter rf voltage
- i. Mass filter ion intensity versus mass count (analog display)
- j. Electronics box (housekeeping parameters, maximum of 10 to 12)

DATA

Both analog and digital signals will be applied to the Orbiter data systems. They will be as follows:

| <u>Parameter</u> | <u>Type</u> | <u>Amplitude (volts)</u> | <u>Word Length (bits)</u> | <u>Bit Rate (bps)</u> |
|--|-------------|------------------------------|-----------------------------------|------------------------------|
| Bottle number | D | — | 6 | 0.1 |
| Gas mode | D | — | 2 | 2 |
| Wavelength | D | — | 2 x 8 | 3200 |
| Intensity | D | — | 8 | 3200 |
| Voltage (rf) | D | — | 2 x 8 | 1 x 10 ⁴ |
| Mass count | D | — | 2 x 8 | 1 x 10 ⁴ |
| Ion intensity | D | — | 2 x 8 | 5 x 10 ⁴ |
| Manifold pressure | A | 0-5 | 8 | 80 |
| Nozzle temperature | A | 0-5 | 8 | 80 |
| Chamber pressure | A | 0-5 | 8 | 80 |
| Photodiode signal | A | 0-5 | 8 | 800 |
| Chamber temperature | A | 0-5 | 8 | 8 |
| Electronics house- keeping (12 lines) | A | 0-5 | 8 | 96 (12 x 8) |
| Total | | | | <hr/> 7.75 x 10 ⁴ |

A = analog, D = digital. Orbiter analog to digital conversion will be assumed for the analog parameters. When operated in a gas release mode only, the data rate will be 100 bps.

DEVELOPMENT STATUS

FORERUNNER INSTRUMENTS

Each of the subsystems of this instrument exists in one form or another, and some have flown in space successfully (e.g., monochromator on Apollo 17, quadrupole mass filter on Atmosphere Explorer (AE) satellites). All of the subsystems should be within the state-of-the-art.

PROBLEMS

Design and Manufacturing: Some theoretical work remains to be done on the rates of interaction in the various gas species.

Operational: The main operational problem will be to avoid contamination of the monochromator optics and the electron multipliers.

OPTICAL BAND IMAGER AND PHOTOMETER SYSTEM (OBIPS)

INSTRUMENT 534

OBJECTIVE

The Optical Band Imager and Photometer System (OBIPS) will obtain radiometrically quantitative monochromatic images of faint, transient phenomena, such as natural auroras, artificial auroras, glows produced by chemical tracers, and other perturbation phenomena. The optical passband of each photometer unit will have a preselected wavelength interval whose center will correspond to the wavelength of the band or line emitted by a particular molecular, ionic, or atomic species. Thus, distribution images of particular excited species will be obtained.

The pointing will be done either manually or by computer. Where the atmosphere is perturbed so as to emit, the direction of the phenomenon will be calculated and the units turned automatically in that direction.

Two units will have narrow fields of view, and their objective will be as photometers to measure the radiance in a small region rather than as imaging sensors. Their direction will be controlled manually by observing the television (TV) images of the wider field sensors.

The units will be versatile and modular and can be adapted to a wide range of experiments. Interchangeable filters and lenses will be part of this versatility.

GENERAL DESCRIPTION

LOCATION

This instrument will be mounted on the pallet.

CONFIGURATION

The exact configuration of this instrument is still under study; however, it is expected to consist of two narrow field filter photometers, a narrow

angle low light level TV camera with an extended S-25 response intensifier, and an ultraviolet TV camera with response extending below the Lyman-Alpha hydrogen line.

A cover will be necessary to eliminate contamination of the optical surfaces. A door, located between the lens and sunshade, will slide open just before data taking.

Each unit will have a sunshade which will be collapsible to save space when the instrument is not in use. It will be large in order to provide baffling against off-field radiation. An important case will be viewing the air glows above the horizon during daylight. This will require high capability for off-axis rejection.

The lenses will have different angular fields of view and will be interchangeable between missions. The apertures will be large in order that faint glows may be sensed. They may be either mirrors, transmitting lenses, or a combination.

Interference filters, absorption filters, or a combination may be used to make the image monochromatic. In some cases, the imagery may be broadband. The filters will be interchangeable during a mission, so that different species may be observed for different experiments. A simple method of accomplishing this will be with a turret mount, if space permits.

Two units will be TV cameras and will be interchangeable for different missions. Candidate cameras are: (1) the 40-mm Silicon Intensifier Target and (2) the microchannel plate with charge coupled detector which is under development. The requirements will be high sensitivity, quantitative accuracy, and good background suppression. One of the cameras may be ultraviolet (UV), depending upon the mission. The detectors for the photometers will be photomultipliers, one of which may be UV.

All units will be located on the pallet.

SPECIFICATIONS

Spectral Characteristics: The spectral characteristics of the instrument will be determined by the characteristics of the filter and photocathode. These will be selected for the particular experiments or mission.

Resolution and Sensitivity: The angular resolution of the system will be determined by the focal length (and, thus, the total field angle covered), and the size and resolution of the TV subsystem. This subsystem should be capable of 200 TV lines at a faceplate illumination of 10^{-6} meter-candles at 5400 Å and at the spectral response defined by the S-25 photocathode surface, or alternatively a surface of lower resolution and higher sensitivity, or one sensitive in the UV.

Field of View: The field of view of the photometers will vary from 0.5° to 2° with a variable field stop. The TV systems will have fields of view from 5° to 160° , depending upon the choice of lenses.

The off-axis rejection must be as high as possible in order to exclude spurious radiation from lower levels for observations at higher levels where the radiation is faint. This will be especially important during daylight. A nominal desired objective for a 10° field lens is 10^{-6} rejection at the axis for radiation 2° outside the field of view. If a 160° lens is used, the off-axis rejection will not meet these specifications.

The geometry of the platform and gimbals will permit an unobscured field over a full hemisphere or 2π sr. Booms in the field will cause a severe flare problem during daylight.

One configuration will be photometers at two different wavelengths: a TV with a 5° field and a TV with a 20° field. Another is both TV's with the same field but at different wavelengths.

Data Collection Rate: The scan modes will be: (1) a conventional TV raster at 30 frames/sec and (2) integration modes at 0.1, 1, 2, 4, and 8 sec. All units will be synchronized to obtain temporal registration later.

Each TV will have a bandwidth up to 4 MHz. The photometers will have a bandwidth of 20 kHz.

Power: Each TV unit will require 20 W average at 28 V and a maximum of 40 W. Two units will require an average of 40 W and 80 W, maximum. The standby power will be 10 W. Each photometer unit will require 5 W.

Physical Dimensions:

Size: The camera unit, filter, and lens will be 0.2 x 0.2 x 1.3 m or 0.052 cu m. The shield may be as large as 0.9 x 0.9 x 1.8 m, giving a total length of 3.1 m. It may be possible to fold up the shield when not in use in order to save space.

Weight: Estimated 100 kg for four units without the steerable platform; however, the baffling shields to minimize stray radiation may cause the weight to be significantly greater.

OPERATION

POINTING REQUIREMENTS

The pointing accuracy to 2° will be required. However, the attitude must be known to 0.02°. This accuracy will be necessary for the analysis of injection experiments.

STABILIZATION AND TRACKING REQUIREMENTS

Angular rates less than 1 deg/min will be required.

TIMELINE

Typically, the time and direction of a particular phenomenon has been calculated previously and the instrument pointed toward it. Just before data collection, the protective cover or door will be opened. The calibration source will be put in place and activated, then it will be turned off and removed. A design which permits calibration without moving a light source may be feasible.

The selection of the particular mode of operation will be made and data taking started. The location of the glow on the display will show the place where the narrow field photometer should be pointed, and the direction of the system will be trimmed manually to put the photometer on target. The scientific data will be ended manually, for example, when the glow on the display disappears.

The calibration cycle will be repeated and the door closed.

CONSTRAINTS

The sun cannot be viewed without damage to the instrument. Daylight will reduce or eliminate the visibility of the phenomena; however, some daylight observations will be planned.

CHECKOUT AND TEST

BORESIGHTING REQUIREMENTS

Boresight between the photometers must be accurate to 0.01° or the resolution of the photometer if it has a greater angle. This must be checked via the displays. The input to the subsystems to perform this is TBD. In addition, the orientation of the photometers with respect to the Orbiter attitude indication must be known to 0.02° .

PRELAUNCH CHECKOUT

Checkout can be accomplished with collimators focused on film images and observers looking at the TV displays for clarity.

PREFLIGHT CALIBRATION

A calibration cycle will be performed and the measured values compared with a GSE standard source which will be placed in front of each subsystem.

INFLIGHT CALIBRATION

The calibration cycle will be performed. The source to be used is TBD.

CONTROLS

| <u>Mode or Operation</u> | <u>Number of Positions</u> |
|--------------------------|----------------------------|
| Door open/close | 2 |
| Sunshield in position | 2 |
| Aperture control | 10 |
| Filter selection | 3 to 10 |
| Gain | 10 |
| Mode of TV operation | 6 |
| Calibrator position | 2 |
| Calibrator light on/off | 2 |
| Pointing | (TBD) |

DISPLAYS

The displays will include one video TV monitor for each system and one light for each of the following: the door open, a sunshield position, and a calibrator position.

DATA

SCIENTIFIC

The maximum video output requires a bandwidth of 4 MHz for each of two units. For some modes, the actual data rate will be considerably less. In addition, the photometers will have a maximum digital bit rate of 1 kbps for a total of 2 kbps.

HOUSEKEEPING

The following housekeeping parameters will be recorded:

- a. Temperature of each TV sensor, accuracy of 1°C, and range -20° to +40° C.
- b. Pointing direction, accuracy of 0.02°.

- c. The middle time of every TV picture (halfway between beginning and end of exposure) accurate to 0.003 sec, at a maximum rate of 30 times/sec.
- d. Control settings of each item listed in the preceding paragraph.

DEVELOPMENT STATUS

FORERUNNER INSTRUMENTS

No instrument corresponds exactly to this description, but all components exist except for the baffle design.

PROBLEMS

Design and Manufacturing: The primary problem areas will be the TV selection and development, the pointing problem, the Orbiter location accuracy, the off-axis rejection specification, and calibration. None of these should prevent implementation but may require compromises. Considerable work on optimization and tradeoffs will be required.

The development of TV sensors which go farther into the ultraviolet will give added versatility and utility.

The most critical factor in determining the performance will be the TV which must be extremely sensitive and quantitative.

Operational: No critical operational problems are anticipated. A boom or any part of the Orbiter in the field of view will cause flare during daylight and obliterate the images.

A possible solution to the problem of preventing the lower atmosphere from causing flare during daylight will be to use the Orbiter to block the radiation reflected from the earth and lower atmosphere.

TRIAxIAL FLUXGATE

INSTRUMENT 536

OBJECTIVE

The objectives of this instrument are: (1) to study the natural hydromagnetic wave propagation in the ionosphere waveguide and (2) to probe the ultralow frequency (ULF) noise generated by the Orbiter vehicle and also the controlled discharges from a long tether on the ULF antenna of Instrument 407. It may also be used to determine the magnetic field vector.

GENERAL DESCRIPTION

LOCATION

This instrument will be mounted on a subsatellite or Orbiter boom.

CONFIGURATION

If subsatellite mounted, the triaxial fluxgate magnetometer will be mounted on a 2-m boom, probably extendable, to remove the instrument from localized EMI around the subsatellite. Because of stringent B-field interference requirements, the contemplated instrument may not operate near the Orbiter, but an off-the-shelf, less sensitive unit could be boom mounted.

The probes for this type of magnetometer will consist of two ac excited coils wrapped antiphase on a high permeability core form. A pickup coil, consisting of many turns to take advantage of the step-up transformer effect, will be wrapped on the same form and will measure phase change, bridge unbalance, or voltage output caused by imposing an external magnetic field on the core. Three sets of coils oriented in the X, Y, and Z coordinates will be mounted together. Pickup coil information will be received by the electronics and processed to give local field intensity and vector direction.

The instrument will measure hydromagnetic waves below 0.1 Hz frequency with amplitudes above 5×10^{-7} gauss and will only operate efficiently in EMI

below 3×10^{-7} gauss rms. The ambient dc field, by comparison, can be a factor of 10^6 larger than the desired data.

As data from this instrument are not only a basic measurement of natural phenomena but also required for other instruments, the Triaxial Fluxgate can have combined usage with instruments, such as D. C. Electric Field (Instrument 535) or VLF Wave Field Measurements (Instrument 416). By specifying magnetometers no more sensitive than is required for a specific application, costs can be reduced.

This instrument will measure basic natural parameters and will not require other instrument data in its data reduction. However, low EMI requirements will dictate that it be mounted in a subsatellite. As the D.C. Electric Field (Instrument 535) requires local magnetic field data, putting the two instruments together, if there are no gross EMI problems, will be an optimum arrangement. The objective of this instrument will not be to measure the local field strength but it will have the capability if properly calibrated.

SPECIFICATIONS

Sensitivity: 5×10^{-7} gauss. For some applications, less sensitivity will be acceptable.

Data Collection Rate: essentially continuous after deployment

Power: 4 W at 28 Vdc

Physical Dimensions:

Size:

- a. Boom mounted magnetometer — 0.1 x 0.1 x 0.1 m
- b. Supporting electronics — 0.1 x 0.1 x 0.2 m

Weight:

- a. Boom mounted magnetometer — 2 kg
- b. Supporting electronics — 3 kg

Other: Subsatellite with inertial stabilization. Some temperature control will be required to protect electronics and the power supply. Telemetry electronics can be shared with Instrument 535 or other instruments with which it may be combined.

OPERATION

POINTING REQUIREMENTS

Instrument attitude in relation to earth inertial coordinates must be known to 0.5° in pitch, roll, and yaw.

STABILIZATION AND TRACKING REQUIREMENTS

The location of the subsatellite must be known to a few kilometers. The optimum roll rate will be about one revolution in 1000 sec but one revolution in 10 sec will be acceptable. As roll rate increases, data reduction will become more complicated. A subsatellite stabilized in relation to its direction of travel will be the best configuration.

TIMELINE

Operation will be essentially continuous except near the Orbiter where EMI can be a problem.

CONSTRAINTS

EMI below 3×10^{-7} gauss or 0.03 γ

CHECKOUT AND TEST

(TBD)

CONTROLS

The following controls will be required:

- a. Power up command
- b. Various sampling rates

- c. Changes in data format by commands to microprocessor contained in subsatellite
- d. Display controls

DISPLAYS

The following displays will be required:

- a. Overlay display of power spectra of each subsatellite component of the magnetic field vector
- b. Wave propagation vector and polarization display over a broad range of narrow frequency bands
- c. Feedback of command controls

DATA

SCIENTIFIC

Digital data at a rate of 600 bps on one channel showing B_x , B_y , B_z , or a combination of the three.

HOUSEKEEPING

Commutated with above data will be housekeeping data showing sensor and electronic temperatures. Satellite location and pitch, roll, and yaw data may be transmitted but could be ignored by onboard processing.

DEVELOPMENT STATUS

FORERUNNER INSTRUMENTS

None specified although fluxgates have been flown.

PROBLEMS

Design and Manufacturing: Further instrument development will be required to achieve the desired sensitivity to natural wave amplitudes.

Operational: (TBD)

GAS PLUME RELEASE
(AMPS PARTICLE ACCELERATOR SYSTEM LEVEL I DIAGNOSTIC)

INSTRUMENT 549

OBJECTIVE

The Gas Plume will be utilized primarily for the determination of accelerator produced electron and ion beam flux densities and emergence angles by means of optical observations of the excitation of the released gas. In addition, the plume will provide ion-electron pair generation for ion release/electron return satisfaction of Orbiter current neutralization during electron beam release. The gas plume will provide high number, high density, low energy plasma bursts to use as magnetic field line markers and, also, as a means of performing neutral and ion gas chemistry experiments in a nonbounded configuration.

GENERAL DESCRIPTION

LOCATION

This instrument will be mounted inside the Electron Accelerator (Instrument 303), which will be located on the pallet.

CONFIGURATION

The gas plume release will consist of a gas storage tank, regulator valves, a plenum chamber, and gas pop valves for release of gas to four nozzles. The entire system (excluding controls) will occupy unused volume inside the electron accelerator of the AMPS particle accelerator system. See figures 549-1 and 549-2. In operation, gas will be fed from the storage tank to a regulated pressure in a plenum chamber and released to space through four nozzles. The nozzles will be situated such that the plume will expand over the exit ports of the electron and ion accelerators and, thereby, provide, through ionization by the electron or ion beams, a qualitative visual indication of beam profile, beam direction, and beam intensity. The plume will be viewed by an onboard television camera (not part of this system) and retained on video tape for examination by the accelerator operator.

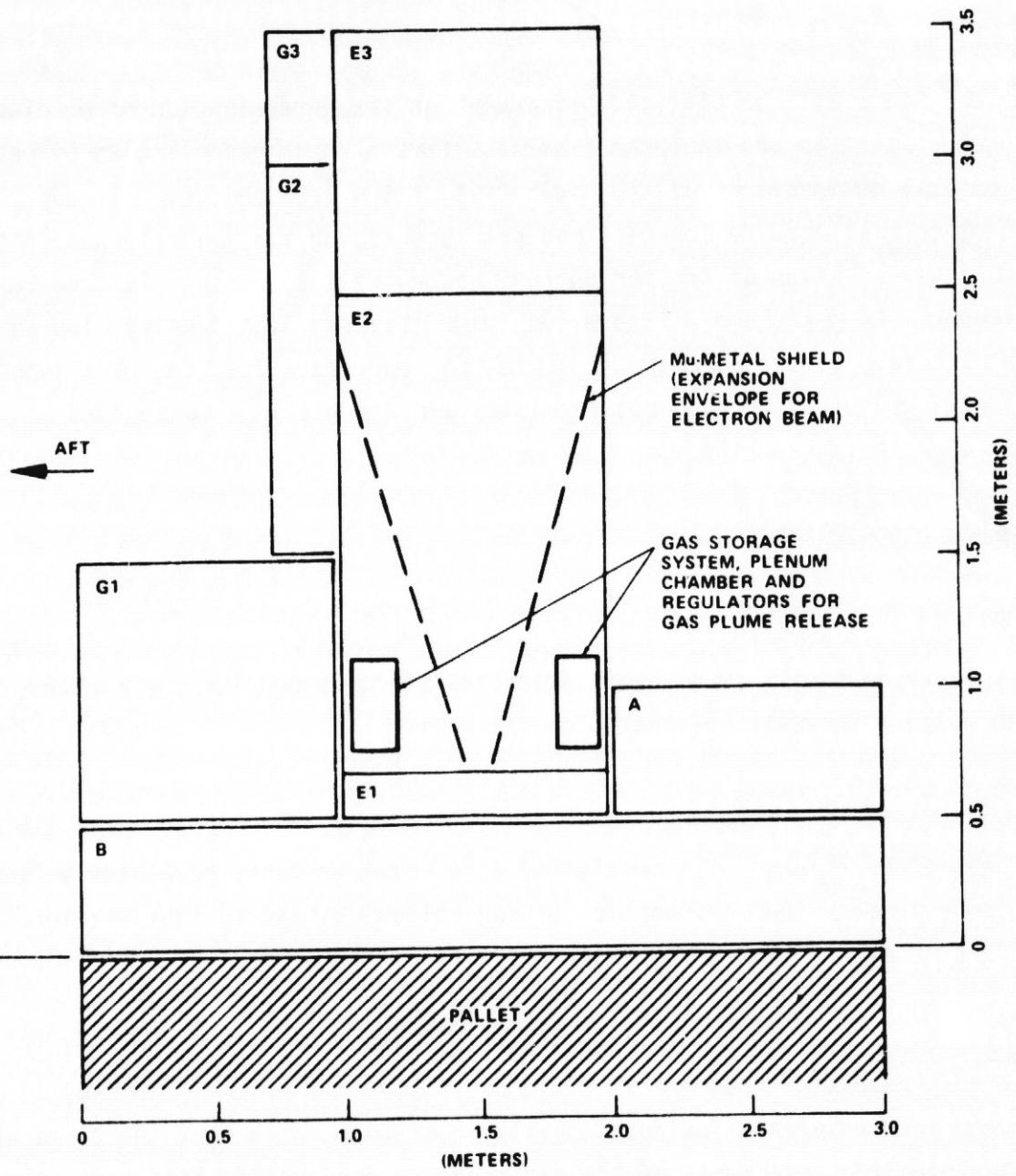

Figure 549-1. - AMPS Particle Accelerator System Y-axis view locking port.

**ORIGINAL PAGE IS
OF POOR QUALITY**

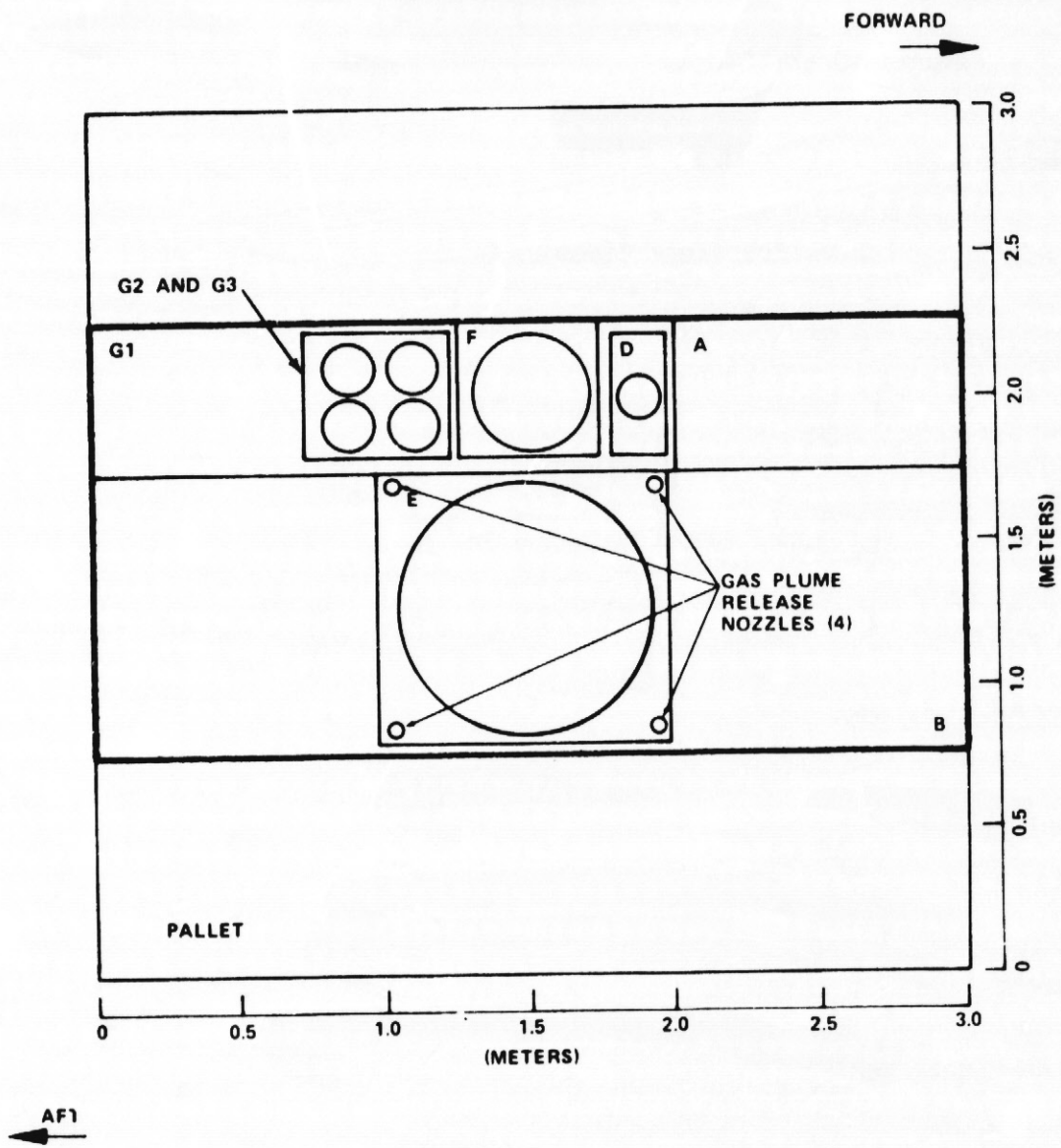

Figure 549-2. - AMPS Particle Accelerator System Z-axis view looking down.

The sequencing of the valves of the gas system and also the initiation of video taping of the gas release must be time coordinated with the sequencing controls of the accelerators.

SPECIFICATIONS

Plenum Pressure: 0 to 15 psia

Gas Release Burst: 0 to 0.5 moles/burst

Gas Species: simple laboratory gases

Burst Duration: 0.01 to 1 sec

Plume Half-Angle: 30°

Nozzles: 4

Power: 28 Vdc: 5 W (standby), 5 W average and 10 W maximum (operating)

Physical Dimensions:

Size: 0.12 cu m (fits into unused space in the Electron Accelerator, Instrument 303)

Weight: 9 kg

OPERATION

POINTING REQUIREMENTS

Not applicable.

STABILIZATION

Not applicable.

TIMELINE

The instrument will operate for 4 hr/day, concurrent with accelerator operation. Standby condition will occur only during this period.

CONSTRAINTS

None.

CHECKOUT AND TEST

BORESIGHTING REQUIREMENTS

Not applicable.

PRELAUNCH CHECKOUT

The only checkout required will be to activate the system, cycle the valves, and read pressures from the housekeeping system. GSE gas servicing will be required for the gas storage tank.

PREFLIGHT CALIBRATION

Not applicable.

INFLIGHT CALIBRATION

Not applicable.

CONTROLS

The gas plume release will be controlled from the accelerator control console by means of a sequencing program that will also control the accelerators.

The specific controls for the gas release will be:

- a. Gas supply — open/close
- b. Nozzle valves — open/close (four)

DISPLAYS

Display will be in the form of a replay of several seconds of television from video tape.

DATA

SCIENTIFIC

This data will be approximately 3 sec of video (taped) per burst.

HOUSEKEEPING

The housekeeping data requirements will be:

- a. Gas storage pressure — 8-bit word, 8 bps
- b. Plenum pressure — 8-bit word, 8 bps

DEVELOPMENT STATUS

FORERUNNER INSTRUMENTS

The gas plume release will be a relatively simple gas flow system. The storage containers, regulators, and valves have very likely flown previously in some spacecraft configuration.

PROBLEMS

Design and Manufacturing: No design or manufacturing problems are anticipated.

Operational: The possibility of contamination of other instruments (e.g., cryo-cooled spectrometer) by the gas plume exists. Also problems of corona and breakdown within the accelerator system must be studied as well as beam instabilities which may exist in the presence of the gas.

FARADAY CUP PROBE
RETARDING POTENTIAL ANALYZER
COLD PLASMA PROBE
(AMPS PARTICLE ACCELERATOR SYSTEM LEVEL II DIAGNOSTICS)

INSTRUMENT 550

OBJECTIVE

The level II diagnostic instruments will determine: (1) the current densities (spatial profiles) in the electron and ion accelerator beams utilizing the Faraday cup probe, (2) the charged particle acceleration energies in the electron and ion beams using the retarding potential analyzer (RPA), and (3) the exhaust beam plasma potential using the cold plasma probe. The information supplied by these three instruments will complement that obtained by the Gas Plume Release (Instrument 549).

GENERAL DESCRIPTION

LOCATION

This instrument will be mounted on the boom.

CONFIGURATION

The level II diagnostic instruments will be used for defining the ion and electron accelerator beams, current density profiles and beam energy determination, and for a measure of vehicle charging due to non-neutralized currents from accelerators. The three instruments will be mounted together on a dedicated boom. When required, the instrument package will be positioned and/or scanned over the accelerator exit aperture. Scanning of the electron beam can be accomplished in two different ways. The electron beam may be held stationary and the diagnostics scanned across it, or the diagnostics may be held stationary and the electron beam scanned electromagnetically by means of the steering coils built into the electron accelerator. The latter case is the more desirable, because scanning could be accomplished

with a single beam burst. The ion beam will have to be scanned by mechanical movement of the diagnostic package, because this accelerator will lack electrical steering.

The envelope of the movement of these diagnostic instruments over the accelerators will be as follows. Defining the center of the beam exit aperture of the Electron Accelerator (Instrument 303, see figure 303-4) as the point $X' = Y' = Z' = 0$, the probe group movement should be within the volume defined by:

$$0 \leq X' \leq 5 \text{ m}$$

$$0 \leq Y' \leq 5 \text{ m}$$

$$0 \leq Z' \leq 10 \text{ m}$$

The probe group should also be capable of movement for insertion into the ambient space plasma. However, details of the positions are TBD.

Faraday Cup Probe: The Faraday cup probe will be a simple current collecting device which will be a cylindrical cavity with a 10-cm diameter entrance aperture. Two separately biasable grids will allow suppression of secondary electrons created by incident particle bombardment of the collector plate and exclusion of low energy ions or electrons impinging on the entrance aperture. The design of the cup should allow for a rapid response, as the electron beam can be modulated up to 10 MHz.

Retarding Potential Analyzer (RPA): The RPA will consist of a cylindrical collecting volume, at the rear of which will be a collecting plate. A biasable entrance grid will allow the suppression of low energy nonbeam associated ions or electrons. Next in line will be a retarding grid whose bias (both polarity and magnitude) will determine the minimum energy of the particles which can penetrate it and reach the collector. Situated between

the retarding grid and collector will be a suppressor grid which will be held at a negative potential high enough to suppress secondary electrons from leaving the collector.

Cold Plasma Probe: The cold plasma probe will be a passive device which can be used to give an indication of the Orbiter charge buildup during operation of the electron and ion accelerator. In this system, a boom mounted electrode, essentially electrically isolated from the Orbiter, will be immersed into the ambient space plasma in the vicinity of the Orbiter. The electrode will come to some static potential which will be near the potential of the plasma. By appropriate measurement of the potential difference (if any) between the electrode and the Orbiter, the potential of the Orbiter with respect to the ambient plasma will be obtained.

SPECIFICATIONS

Faraday Cup Probe:

Current density: 10^{-6} to 1 A/sq cm

Cup diameter (aperture): 10 cm

Suppression grids: two separately biasable

Maximum permissible energy inputs per burst: 10^4 J

Retarding Potential Analyzer:

Energy range: 0 to 30 kV

Energy resolution ($\Delta E/E$): 0.01

Minimum current density: 10^{-6} A/sq cm

Number of grids: three separately biasable

Aperture diameter: (TBD)

Cold Plasma Probe:

Readout accuracy: ± 2 V

Minimum current density: 10^{-6} A/sq cm

Power: 28 Vdc: 5 W (standby), 10 W average and 20 W maximum (operating)

Physical Dimensions:

Size:

- a. Faraday cup probe — 0.1 x 0.1 x 0.1 m, 0.001 cu m
- b. RPA — 0.15 x 0.15 x 0.15 m, 0.003 cu m
- c. Cold plasma probe — 0.1 x 0.1 x 0.1 m, 0.001 cu m

Weight:

- a. Faraday cup probe — 9 kg
- b. RPA — 9 kg
- c. Cold plasma probe — 5 kg

OPERATION

POINTING REQUIREMENTS

Not applicable.

STABILIZATION

Not applicable.

TIMELINE

These instruments will be for accelerator beam diagnosis and will operate only within the timeline of operation of the accelerators which will be 4 hr/day.

CONSTRAINTS

(TBD)

CHECKOUT AND TEST

BORESIGHTING REQUIREMENTS

Probably only a mechanical check will be required.

PRELAUNCH CHECKOUT

The control and data systems of the instruments will be activated and house-keeping parameters checked. Current amplifiers will be checked with an accurate current source. High voltage systems will not be activated at atmospheric pressure.

PREFLIGHT CALIBRATION

None.

INFLIGHT CALIBRATION

None.

CONTROLS

These instruments will require the following controls:

- a. Faraday cup probe
 1. Outer grid potential
 2. Inner grid potential
- b. Retarding potential analyzer (RPA)
 1. Outer grid potential
 2. Retarding potential*
 3. Suppressor grid potential

*The retarding potential will be a swept voltage ramp which must be synchronized with the accelerator beam burst.

- c. Cold plasma probe - none
- d. All instruments - power on/off

DISPLAYS

The outputs of these three instruments can be in the form of transient signals. For proper accelerator operation, the pulse shapes of the signals need to be displayed in near real time. Bandwidths can range up to 10 MHz. Consequently, the signal outputs should be digitized by fast analog-to-digital converters and stored in associated memories for subsequent reversion to analog and displayed on the CRT. These rapidly varying parameters will be:

| <u>System</u> | <u>Parameter</u> |
|------------------------------|---------------------|
| Faraday cup probe | Collector current |
| Retarding potential analyzer | Retarding potential |
| Retarding potential analyzer | Collector current |
| Cold plasma probe | Current |
| Cold plasma probe | Floating potential |

In addition, the peak or average values of all of the above parameters, plus several housekeeping parameters, should be sampled and displayed on the CRT. It is estimated that there will be a total of approximately 15 to 20 parameters.

DATA

SCIENTIFIC

The scientific data will consist of the waveforms of several transient pulse parameters rapidly digitized (non-RAU) to 8-bit words. The parameters are listed on the following page.

| <u>System</u> | <u>Parameter</u> | <u>Bandwidth (MHz)</u> | <u>Bit Rate (kbps)</u> |
|------------------------------|---------------------|----------------------------|----------------------------|
| Faraday cup probe | Collector current | 10 | 2.5 |
| Retarding potential analyzer | Retarding potential | 0.1 | 0.5 |
| Retarding potential analyzer | Collector current | 1 | 1.5 |
| Cold plasma probe | Current | 1 | 1.5 |
| Cold plasma probe | Floating potential | 0.1 | 0.5 |

HOUSEKEEPING

There will be approximately 10 to 15 housekeeping parameters whose average or peak values must be sampled and digitized to 8-bit words at 0.1 sps for a bit rate of approximately 12 bps.

DEVELOPMENT STATUS

FORERUNNER INSTRUMENTS

RPA's exist and have flown on several satellites. The Faraday cup probe and the cold plasma probe are passive sensors used extensively in ground based ion and plasma studies respectively. All three devices should be within the state-of-the-art.

PROBLEMS

Design and Manufacturing: Although RPA's have flown, the present concept involves retarding voltages to 30 kV. A significant design effort will be required to cope with problems of corona and voltage breakdown. A careful calibration must be performed to take into account secondary emission. It may be simpler to utilize a curved plate electrostatic analyzer instead of a RPA.

Operational: No operational problems are foreseen.

PYRHELIOMETER AND SPECTROPHOTOMETER

INSTRUMENT 1002

OBJECTIVE

The Pyrheliometer and Spectrophotometer will measure the solar constant and the solar spectral irradiance with state-of-the-art absolute accuracy and will determine with higher precision the possible variations of the total and spectral flux associated with cyclic and sporadic changes in the sun.

This instrument will determine the effect of solar variations on the weather and on climatic changes. In addition, the value of the solar radiation appears not only in meteorological and climatological equations but also equations involving pollution, the earth's heat budget, and physical and chemical processes in the upper atmosphere. Only a small change in irradiance will be sufficient to significantly change the climate. Changes of these magnitudes cannot be measured accurately from within the earth's atmosphere. There is considerable controversy at the present time about the value of the solar constant. Variations have been detected, but disagreement exists about the extent of variation.

The means of measuring the solar flux will be with the Pyrheliometer (Instrument 1002), which will measure the total irradiance, and a Spectrophotometer (Instrument 1003, spectroradiometer), which will measure the spectral distribution of the radiation. Both will be calibrated as accurately as the present state-of-the-art permits. Some controversy exists over the absolute value of present standards, but calibration with reference to present standards and the measurement of changes of solar radiation will be adequate for most purposes. Both measuring devices will be needed, because not only the total energy is important, but the impact of radiation on the earth depends upon the spectral distribution as well. The Pyrheliometer will be more accurate and will serve as a check on the Spectrophotometer data, i.e., the integral over the latter must agree with the former.

It will be important not only to make measurements from the Orbiter but also to calibrate instruments on other satellites and determine the effects of space, radiation, and contamination on these instruments.

In addition to observing the sun, the instrument may be used in the earthward direction to measure the albedo; although, it will be better for a second instrument to measure the radiation from the earth at the same time that the first instrument is measuring the solar radiation.

GENERAL DESCRIPTION

LOCATION

This instrument will be mounted on the pallet.

CONFIGURATION

The design will be called the Solar Energy Monitor in Space (SEMIS). Both the Pyrhelimeter and Spectrophotometer will be in the same package. The entrances to the two instruments will form a parallel pair as shown in figure 1002-1.

The Pyrhelimeter will be a thermopile, commonly used as a standard, modified similar to that of the Nimbus Earth Radiation Budget experiment. It will be located in chamber C. A circular baffle will limit the field of view.

In addition, a wirewound conical Pyrhelimeter is under development which is expected to be more accurate. Solar radiation will be absorbed in a hollow cone. The cone will be heated electrically to maintain a constant temperature. The cone will radiate heat backwards to a constant temperature cooled sink. Changes in solar radiation will be measured as power changes in the cone. This may be used in addition to the one described above or replace it.

The Spectrophotometer will operate as follows. Solar radiation will reflect off a diffusing plate. This will negate any need for scanning the sun, because the diffusing plate will effectively perform the integration over

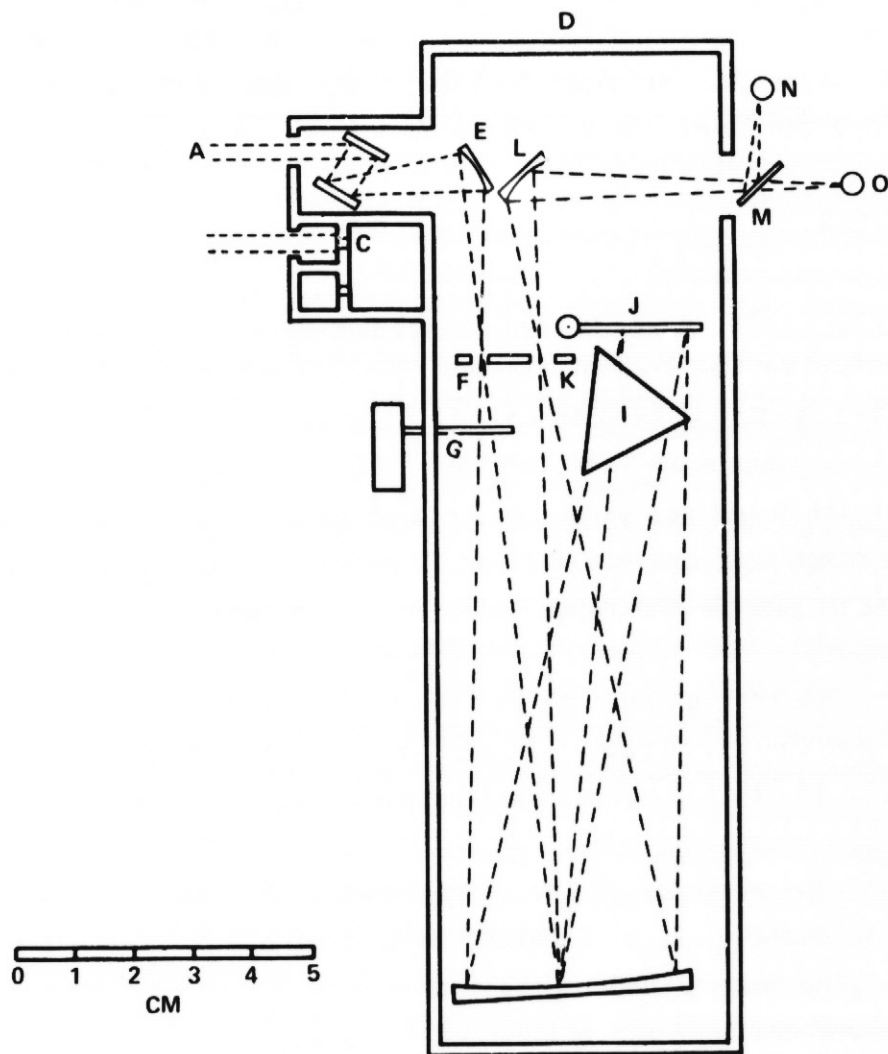

Figure 1002-1. - Spectrophotometer and Pyrheiliometer optical schematic.

over the solar disc. A mirror (E) will focus the diffusing plate on the entrance slit. The radiation will go through a slit (F) and a chopper (G) and be collimated by a larger mirror. The radiation will be dispersed by a quartz prism (I); a Littrow mirror (J) will pass it through the prism a second time, and it will be focused by the same collimating mirror on the exit slit (K). A focusing mirror (L) and beam splitter (M) will pass the radiation to a photomultiplier (N) for the wavelengths of 0.25 to 1.1 μm and lead sulfide detector (O) for the wavelength range above 0.7 μm .

A door will cover the entrances to both instruments when data is not being acquired in order to eliminate contamination at those times.

SPECIFICATIONS

Spectral Range: The range for the Pyrheliometer will be 0.2 to 5 μm . It will be limited by the transmittance of the protective quartz envelope. The range for the Spectrophotometer will be 0.25 to 2.6 μm at the present time; however, it is planned to increase the wavelength range to 4.0 μm . The fraction of the solar radiation in the 0.25 to 2.6 range will be 96 percent and in the range 0.25 and 4.0 will be 99 percent. The small corrections for radiations outside the ranges will be easily made.

Resolution: The resolution $\lambda/\Delta\lambda$ will be 60 to 200 for the Spectrophotometer, depending upon the wavelength. It will be desirable to have a resolution of 100 or better for this purpose, but the exact resolution will not be critical.

Sensitivity: The accuracy of the Pyrheliometer will be 1 percent with respect to present standards. It will detect changes of 0.5 percent. (The wire-wound cone Pyrheliometer under development will be expected to have an accuracy of 0.5 percent, and a precision of 0.1 percent is believed possible.) The present uncertainty in the solar constant is ± 1.5 percent.

The signal-to-noise ratio for the Spectrophotometer will be 1000. Its absolute accuracy with respect to present standards will be 5 percent at 0.25 μm and 2 percent from 0.4 to 1.0 μm .

Field-of-View: The field of view of the Spectrophotometer and Pyrheliometer will be 5°. The off-axis rejection of both will be high outside the field due to baffles which will precede any of the optics.

Data Collection Rate: One sample/min will be obtained from the Pyrheliometer and 270 pairs of samples/min from the Spectrophotometer.

Power: The combined power for data acquisition of both units will be 10 W average and maximum. During warmup, which will require a few minutes, the consumption will be 2 to 3 W.

Physical Dimensions:

Size: 30 x 30 x 10 cm with the 30 x 10 cm side toward the sun.

Weight: less than 10 kg

Contamination: When not in use, the optical surfaces will be protected by the door against contamination. Some degradation of the optical surfaces will occur during operation; however, the resulting decrease in responsivity will be measured by inflight calibration and later compensated in the data processing. Protection of the calibrating radiation source against contamination will be even more critical than for the sensor.

Polarization: The response to polarized radiation will be known.

OPERATION

POINTING, TRACKING, AND STABILITY REQUIREMENTS

The instrument must be pointed at the sun with an error not to exceed 2.5°, which would result in an error of 0.1 percent in measuring the solar radiation.

TIMELINE

The operation or scan frequency will be 2 or 3 times per daylight half-orbit. The scan time for the spectrum will be 10 min. The door will be opened before the data take and closed afterward. The power will be activated for warmup a few minutes before data acquisition.

CONSTRAINTS

No other object must be within 20° of the optic axis. Because of the long period of operation, consideration must be given to minimize the accumulation of contamination deposition, such as minimizing refuse dumping during operation.

CHECKOUT AND TEST

BORESIGHTING REQUIREMENTS

The boresight with the sun tracker will be checked to determine if the required pointing accuracy can be achieved.

PRELAUNCH CHECKOUT

Electrical checks will be performed.

PREFLIGHT CALIBRATION

Prelaunch calibration will be made with respect to standard sources and detectors. The procedure will be repeated at postflight.

INFLIGHT CALIBRATION

A calibration light source will swing into the field of view, and the sunlight will be blocked out. A calibration scan will be otherwise identical to a data scan. (Because contamination is an important possible loss of calibration, a duplicate sensor could remain covered except during inter-comparison of instruments, which will be done infrequently, and could act effectively as a calibration source.)

CONTROLS

The following controls will be present:

- a. Door open/close
- b. Power on/off
- c. Initiate data sequence
- d. Initiate calibration

DISPLAYS

A CRT will indicate when the preceding four controls are activated.

DATA

Each record will consist of the following readings: one set of identification data, scan number, time, temperature, and total irradiance followed by 270 sets of readings of the wavelength encoder count, a lead sulfide detector reading, and a photomultiplier reading. A 10-min scan will require 10 records or 1 record/min. The data rate will be less than 20 words/sec. Each word will have 16 bits. The bit rate will be less than 320 bps.

DEVELOPMENT STATUS

FORERUNNER INSTRUMENTS

The SEMIS package is being developed for use on the Orbiter. An experimental package is currently being built and will be used on all routine U-2 flights starting in the summer of 1975. Two models of the small prism Spectrophotometer have been built and are being used in the GSFC Space Environment Simulator. The present design has a long wavelength limit of 2.6 μm because of the quartz prism, but the plan is to extend the range to 4.0 μm by changing to sapphire.

PROBLEMS

Design and Manufacturing: No developmental problems are anticipated. The greatest uncertainty will be the inflight calibration source. However, the expected greater accuracy and precision of pyrhelimeters under development would greatly improve present knowledge of solar variations, and additional instruments should be considered. Candidate pyrhelimeters will be the wirewound conical pyrhelimeter and a dual head pyrhelimeter using electrical compensation and having calibrating blackbodies. Both are under development at Goddard. By the time Orbiter flies, the improved accuracy of the newer pyrhelimeters will probably justify a replacement and/or the addition of one or more new pyrhelimeters.

Operational: The only operational problem will be the contamination of the optical surfaces, although inflight and postflight calibration and time limitation of the operation should reduce the effects.

ULTRAVIOLET OCCULTATION SPECTROGRAPH

INSTRUMENT 1011

OBJECTIVE

The Ultraviolet Occultation Spectrograph will: (1) measure the concentration of molecular species above 100 km in altitude by observing the absorption spectra of stars and the sun as they are occulted by the earth's atmosphere and (2) measure the solar spectrum between 300 and 2000 Å.

The primary relevant species will be H, He, He⁺, O₂, O, O⁺, N₂, N, N⁺, OH, NO, CO, CO⁺, and CO₂⁺, which will have resonance transitions in the 300 to 2000 Å wavelength region. Some of these can be detected by occultation. Between 950 and 2000 Å stars will be preferable to the sun because of the nearly featureless continuous spectrum and because of the greater number of occultations available per mission. Below 950 Å, the interstellar gas will absorb stellar radiation, so the sun must be used. The quantity measured during occultation will be the ratio of spectral radiance during occultation to the spectral radiance before occultation. During occultation, the spectrum will be obtained along a line of sight through the earth's atmosphere. An imaginary parallel line touching the earth's surface will be the corresponding tangent. The distance from the point of tangency to the line of sight will be the altitude. Spectra will be obtained as the altitude decreases. Later, the concentrations of the various species as a function of altitude will be calculated by performing a mathematical inversion of the spectra obtained along the line of sight at the different altitudes.

By monitoring the UV spectrum of the sun, any variations in the solar spectrum, and, therefore, the ultraviolet radiation reaching the earth, may be detected.

This instrument will complement the Airglow Spectrograph (Instrument 116) which will be similar in many design characteristics but will have higher spectral and spatial resolution and less sensitivity.

GENERAL DESCRIPTION

LOCATION

This instrument will be mounted on the pallet.

CONFIGURATION

Because of the different requirements in sensitivity, method of pointing, wavelength range, and optimization, it may not be practical to observe stellar and solar occultations with the same configuration.

Both configurations will consist of collecting optics and a vacuum ultra-violet spectrograph with film recording.

For stellar occultation, a large Cassegrain telescope will be necessary to collect sufficient radiation. For solar work, small collecting optics, the same as for the airglow spectrograph, will be sufficient.

In order to reduce contamination, a covering with a door, which will be open only during data taking, will be necessary. This will cover the external optics as well as the spectrograph.

The design of the spectrograph will be the vacuum type with a slit, concave grating, and recording on the Rowland circle. The simple system will eliminate the reflection losses inherent with more optical elements. Vacuum will be no problem, as on the earth, because it can be vented into space. Also, no window will be necessary or feasible.

The recording subsystem will be a vacuum image intensifier with film. A cesium iodide cathode will have the capability of covering the full desired range of 300 to 2000 Å. There will be no problem with outgassing damaging the photocathode which will be used below 2000 Å, as is the case with photocathodes designed for longer wavelengths. The photoelectrons will be emitted from the same side as the entering photons. They will be accelerated to 20 keV and focused on film by a solenoid. The film will have a thick

emulsion and will be the type used for nuclear work. This arrangement will give good linearity and high sensitivity. One 100-ft roll of 70 mm may be used for 350 exposures. A 1000 ft roll may be desirable for some missions. See figure 1011-1 for an optical schematic of the spectrograph.

A star tracker will be necessary for pointing at a star, and a sun sensor may be necessary for solar occultation.

SPECIFICATIONS

Spectral Range: The wavelength range will be 300 to 2000 Å.

Dynamic Range: (TBD). The dynamic range problem between using the sun and stars for a continuum will not be as severe as might appear at first, because the stars observed are much hotter than the sun and radiate a much larger fraction of their energy in the vacuum UV region.

Resolution: The spectral resolution will be 0.2 to 1.0 Å, depending upon the grating.

Field of View: The estimated field of view, 1 arc min by 0.5° will be determined by the slit width. Obviously, the slit will be parallel to the horizon. For stellar occultation and daylight operation, a narrow slit will be required to eliminate radiation not originating from the star. For use at night, the slit may be much wider. For solar occultation, the slit width will be determined by the altitude, resolution, exposure, and spectral resolution required.

The angular width of view will be critical, because it will determine the pointing accuracy required. The off-axis rejection will be critical when stellar occultation is observed in daylight.

Data Collection Rate: The exposure time will be determined by the exposure required, and the design should not require an exposure so long that altitude

ORIGINAL PAGE IS
OF POOR QUALITY

TOP VIEW

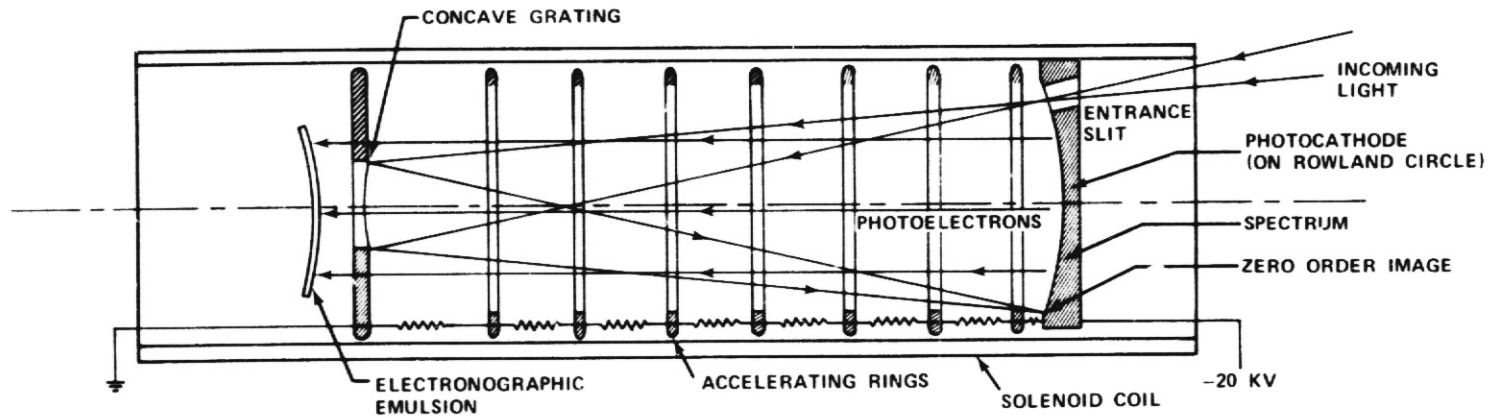

SIDE VIEW

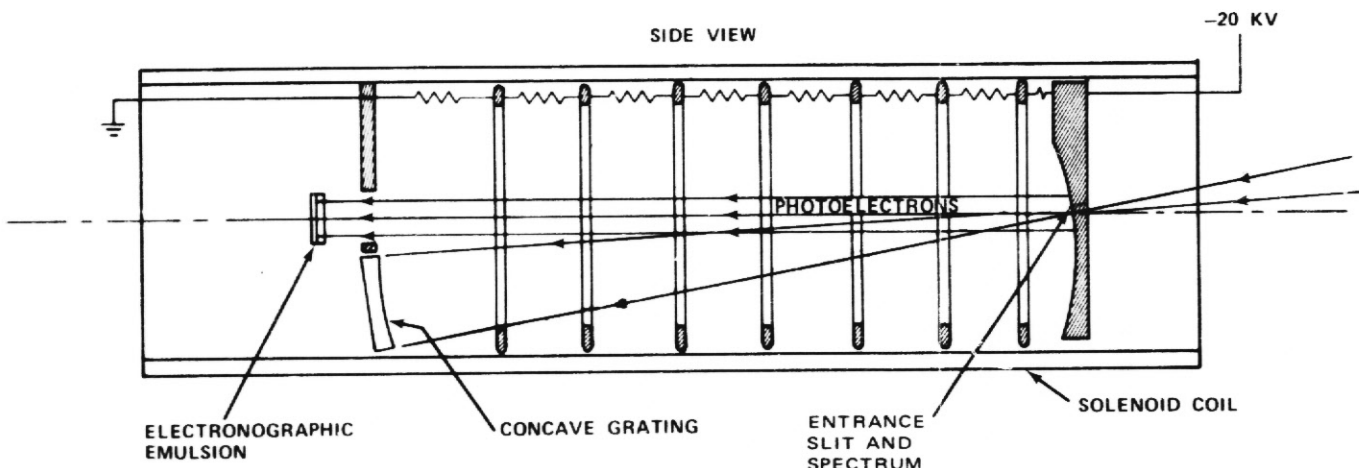

Figure 1011-1. - Ultraviolet Occultation Spectrograph.

1011-4

resolution for the species being measured is reduced. For solar occultation, twenty 1-sec exposures will be typical. For stellar occultation, a single, long exposure, will be taken with the spectrograph moving slowly at right angles to the slit.

For the mode of measuring the radiance of the sun, the sun will be scanned slowly at a rate TBD.

Power: The power required will be a constant 20 W for the focusing solenoid of the electronographic camera. The power required for other spectrograph subsystems such as film advance and the high voltage will be small, about 1 W. Standby, average and maximum power will be the same, but because the warmup time will be short, the standby power will have minimum use. The power for the tracker and pointing will be confirmed during the design and development phase.

Physical Dimensions:

Size:

- a. Spectrograph - 1 x 0.25 x 0.25 m
- b. Cassegrain telescope for stellar occultation - 0.3 to 0.5 m diam, 1 m long, 2 m total (with spectrograph)
- c. Telescope for solar occultation - 0.1 m diam, 0.2 m long, 1.2 m total (with spectrograph)

Weight: 125 kg

Contamination Protection: Contamination will reduce the reflectance of optical mirrors in the ultraviolet much more than in the visible, and optics in the vacuum ultraviolet (below 2000 Å) will be very sensitive. It will be necessary to enclose the telescope in a box to prevent contamination. A door should open to permit transmission of radiation only during data taking. The grating will be less susceptible than the foreoptics because the narrow slit will restrict the entry of contamination.

OPERATION

POINTING REQUIREMENTS

A stellar tracker will be necessary for stellar occultation, and a solar tracker may be necessary for solar occultation. The required pointing accuracy for stellar occultation will be 15 arc-sec in pitch and yaw and 1° in roll; for solar occultation, the required pointing accuracy will be 1 min in pitch, 6 min in yaw, and 1° in roll.

STABILIZATION AND TRACKING REQUIREMENTS

In pitch and yaw, the required stability will be 1.0 arc-sec and the rate 0.1 arc-sec. In roll, the stabilization limit will be 0.1°, and a roll rate limit will not be applicable. The attitude will be internally monitored.

TIMELINE OF DATA COLLECTION

Exposures will start just before detectable absorption. The start should be determined automatically by the time of occultation which has been calculated previously and has been put into the computer. Typically, ten, twenty or more 1-sec exposures will be made. Exposures will end when excessive absorption occurs or the altitude is too low to be relevant. A convenient method of stopping will be a previously determined time interval after start.

CONSTRAINTS

Data can only be taken during the occultation of the sun or a bright star. Because of the spurious radiation during daylight occultations, stellar occultations may be restricted to those occurring during low or no sun. The maximum operation pressure will be 10^{-6} torr.

CHECKOUT AND TEST

BORESIGHTING REQUIREMENTS

The spectrograph must be boresighted with the star tracker to achieve the pointing requirements and with a sun sensor with an accuracy TBD. This can be achieved with the real objects or with a collimator.

PRELAUNCH CHECKOUT

Because evacuating the system is probably impractical, the high voltage cannot be turned on during prelaunch checkout, so only checks of the subsystems can be made.

PREFLIGHT CALIBRATION

Not feasible as described above.

INFLIGHT CALIBRATION

For occultation, only values relative to the star or sun will be necessary, so the instrument will be self-calibrating. Relative accuracy will be 3 percent.

Absolute calibration, for measuring the radiance of the sun, will be accomplished by moving a calibrating source in front of the small telescope. The absolute accuracy is TBD.

CONTROLS

The following controls will be necessary:

- a. Instrument pointing
- b. Tracker on/off
- c. High voltage on/off
- d. Exposure control
- e. Start of data
- f. Calibration source in place
- g. Calibration source on/off
- h. Door open/close
- i. Film advance and exposure sequence

Some of these controls may be preprogrammed so they will be automatic.

DISPLAYS

CRT displays for the following will be required.

- a. Tracker acquisition
- b. High voltage on
- c. Door open
- d. Calibration source in place
- e. Calibration source on
- f. High voltage meter reading
- g. Frame counter

DATA

SCIENTIFIC

The scientific data will be on the film.

HOUSEKEEPING

The housekeeping parameters will include the time of beginning and end of exposure accurate to 0.01 sec. The status of all events under the heading of control and frame number once a second including the high voltage, solenoid current, and solenoid voltage accurate to 1 percent, in an analog format 0 to 5 V.

DEVELOPMENT STATUS

FORERUNNER INSTRUMENTS

The basic design for the spectrograph exists, and an operable breadboard has been built. All subsystems are similar to those used before.

PROBLEMS

Design and Manufacturing: No difficult problems are known to exist, but no work has been done on the pointing or calibration. These are the most complicated areas. It is not known whether the telescopes may be interchanged in flight for stellar and solar occultations or whether two different configurations to be used on different missions is necessary.

Operational: The magnetic field of the solenoid may affect other instruments, and the magnetic fields of other instruments may interfere.

Because of the necessity to obtain data during occultation, it is critical that the starting sequence be initiated at the precise time.

APPENDIX C

| | |
|---|-----|
| ORBITER ENVIRONMENTS | C.1 |
| ENVIRONMENTAL ANALYSES | C.2 |
| INTERFERENCE PROBLEMS FOR AMPS INSTRUMENTS | C.3 |
| SPACE SHUTTLE PROGRAM OFFICE CORRESPONDENCE | C.4 |

APPENDIX C.1
ORBITER ENVIRONMENTS

CONTENTS

| Section | Page |
|---|--------|
| 1.0 ORBITER ENVIRONMENTS. | C.1-1 |
| 1.1 <u>CONTAMINATION</u> | C.1-1 |
| 1.1.1 LAUNCH AND LANDING SEQUENCES. | C.1-2 |
| 1.2 <u>VIBRATION, ACOUSTIC SHOCK AND ACCELERATION ENVIRONMENT</u> | C.1-3 |
| 1.2.1 VIBRATION | C.1-3 |
| 1.2.2 ACOUSTIC. | C.1-5 |
| 1.2.3 ACOUSTIC VIBRATION. | C.1-5 |
| 1.2.4 SHOCK | C.1-7 |
| 1.2.5 ACCELERATION. | C.1-8 |
| 1.3 <u>ELECTRICAL ENVIRONMENT</u> | C.1-13 |
| 1.3.1 RADIATED EMISSIONS. | C.1-13 |
| 1.3.2 RADIATED RF SUSCEPTIBILITY. | C.1-13 |
| 1.3.3 CONDUCTED EMISSIONS | C.1-13 |
| 1.3.4 CONDUCTED SUSCEPTIBILITY. | C.1-17 |
| 1.3.5 BONDING AND LIGHTNING PROTECTION. | C.1-17 |
| 1.3.6 MAGNETIC ENVIRONMENT. | C.1-18 |
| 1.4 <u>RADIATION AND METEOROIDS ENVIRONMENT</u> | C.1-19 |
| 1.4.1 SOLAR RADIATION - (NUCLEAR) | C.1-19 |
| 1.4.2 GALACTIC COSMIC RADIATION - (MAINLY PROTONS). | C.1-19 |
| 1.4.3 TRAPPED RADIATION - (PROTONS, ELECTRONS). | C.1-20 |
| 1.4.4 SOLAR PARTICLE EVENTS | C.1-20 |
| 1.5 <u>THERMAL ENVIRONMENT</u> | C.1-22 |
| 1.5.1 SPACE ENVIRONMENT | C.1-23 |
| 1.5.2 ATMOSPHERE. | C.1-24 |

FIGURES

| Figure | Page |
|--|--------|
| C.1-1 Analytical prediction of the Orbiter payload bay internal acoustic spectrum. | C.1-6 |
| C.1-2 Orbiter payload bay internal acoustic time history | C.1-6 |
| C.1-3 Effects of atmospheric drag on the Orbiter. | C.1-12 |
| C.1-4 Orbiter payload bay internal pressure histories during ascent | C.1-25 |
| C.1-5 Orbiter payload bay internal pressure histories during entry. | C.1-26 |

TABLES

| Table | | Page |
|--------|--|--------|
| C.1-1 | RANDOM VIBRATION LEVEL FOR PALLET PANEL — MOUNTED EQUIPMENT. | C.1-4 |
| C.1-2 | RANDOM VIBRATION LEVEL FOR PALLET HARDPOINT — MOUNTED EQUIPMENT. | C.1-5 |
| C.1-3 | LANDING SHOCK. | C.1-7 |
| C.1-4 | DESIGN ACCELERATIONS FOR 32 K1b DOWN | C.1-9 |
| C.1-5 | ORBITER RCS MAXIMUM ACCELERATION LEVELS. | C.1-11 |
| C.1-6 | ORBITER PAYLOAD INTERROGATOR TRANSMIT AND RECEIVE FREQUENCIES. | C.1-14 |
| C.1-7 | ORBITER FREQUENCY UTILIZATION. | C.1-15 |
| C.1-8 | ORBITER PAYLOAD BAY WALL TEMPERATURE | C.1-23 |
| C.1-9 | SPACE THERMAL ENVIRONMENT. | C.1-23 |
| C.1-10 | ATMOSPHERIC PRESSURE | C.1-24 |

1.0 ORBITER ENVIRONMENTS

1.1 CONTAMINATION

This section describes the natural and induced environments to which the ASF payload may be exposed in the Orbiter cargo bay. These environments are applicable design requirements. However, it must be emphasized that the induced environment data is very preliminary and will be updated as Orbiter and spacecraft test results become available.

Before ASF system installation in the Orbiter cargo bay, all equipment will be closely inspected visually and must be visibly clean. The internal surfaces of the Orbiter payload bay will be cleaned to a visibly clean level as defined in JSC Specification SN-C-0005.

Certain types of materials which do not satisfy the cleanliness requirements because of shedding or outgassing characteristics, etc., are not allowed and these will be determined at a later date. During the same mission sequence certain events will occur which may expose pallet-mounted equipment to various potential contaminants.

Control of the equipment as a source of contamination is exercised by the restriction of the use of materials (details are TBD). Contamination due to required payload venting can be reduced by restrictions on the timing and direction. Orbiter activities requiring gas releases, for example, RCS thruster firing operations, may be properly time-lined to minimize contamination when the cargo bay doors are open. In the Orbiter documentation (Vol XIV, Rev. C) the following design and operational goal is defined.

"Venting of gases and liquids from the Orbiter will be limited for sensitive payloads to control in an instrument FOV particles of

5 microns in size to one event per orbit, to control induced water vapor column density to 10^{12} molecules/cm², or less, to control return flux to 10^{12} molecules/cm²/sec, to control continuous emissions or scattering to not exceed 20th magnitude/sec² in the UV range, and to control the 1 percent absorption of UV, visible and irradiation by condensibles on optical surfaces."

1.1.1 LAUNCH AND LANDING SEQUENCES

1.1.1.1 Prelaunch

The Orbiter will be designed for closed payload bay purging subsequent to payload bay closure using "dry" GN₂ or air which has been HEPA filtered to a class 100 guaranteed class 5000 and which contains 15 ppm or less hydro-carbons based on methane equivalent. The purge gas temperature will be selectable between 7° and 49°C and controlled to ±1°C.

1.1.1.2 Launch Through Orbit Insertion

The level of cleanliness maintained at preflight on the payload and payload bay will be retained through launch to orbital insertion, including liftoff, SRB separation, etc.

1.1.1.3 Reentry Phase (De-orbit to GSE Attachment)

The payload bay will be repressurized using filtered atmospheric air (50 microns absolute). No control of humidity or concentration of other gases will be provided by the Orbiter.

1.1.1.4 Post Landing

The Orbiter design and related GSE will include the capability for closed payload bay purging 30 minutes after touchdown.

1.2 VIBRATION, ACOUSTIC SHOCK AND ACCELERATION ENVIRONMENT

1.2.1 VIBRATION

1.2.1.1 Sinusoidal Vibration

Events such as gust loading, engine ignition and cutoff, separation and docking will induce low frequency transient responses in the Shuttle vehicle. The response for each event for various locations on the pallet is (TBD). However, for the interim, the overall effect of these transient events is accounted for by a swept sinusoidal vibration environment imposed in the frequency range from 5 to 35 Hz at an acceleration amplitude of plus or minus 0.25 g peak.

1.2.1.2 Random Vibration

Maximum vibration levels occur during the launch phase. Equipment mounted on the pallet will be subjected to vibration arising from the overall acoustic level inside the payload bay, and a very minor degree to vibration transmitted through the Orbiter/pallet mounting fixtures into the pallet structure.

1.2.1.3 Panel Mounted Equipment

The vibration levels for equipment mounted directly to a pallet panel are given in table C.1-1.

The weight figures are understood as the sum of all mounted components randomly distributed on the sandwich panels of a pallet. The vibration levels exist for approximately 6 seconds per flight.

Note: The vibration environments are based on presently available data from the Orbiter and will be updated as test results of the Orbiter and Spacelab pallet structure become available.

TABLE C.1-1. — RANDOM VIBRATION LEVEL FOR
PALLET PANEL — MOUNTED EQUIPMENT

| Location | Frequency | Level |
|--|---------------|--------------------------|
| Pallet panel mounted equipment mass <15kg | 20 — 200 Hz | +8 dB/oct |
| | 200 — 700 Hz | 0.72 g ² /Hz |
| | 700 — 900 Hz | -18 dB/oct |
| | 900 — 2000 Hz | 0.166 g ² /Hz |
| | Composite | 26.4 g RMS |
| Pallet panel mounted equipment mass >15kg | 20 — 200 Hz | +8 dB/oct |
| | 200 — 700 Hz | 0.15 g ² /Hz |
| | 700 — 900 Hz | -18 dB/oct |
| | 900 — 2000 Hz | 0.035 g ² /Hz |
| | Composite | 12 g RMS |

1.2.1.4 Hardpoint-Mounted Equipment

Equipment attached to pallet hardpoints is subjected to vibration generated by the adjacent panels, which are excited by the overall acoustic noise level within the payload bay. The actual vibration level to which hardpoint-mounted equipment is exposed depends on equipment mass, number of hardpoints used, additional masses attached to adjacent panels, surface of considered equipment, etc.; therefore, it is necessary to perform a payload accommodation study for large equipment mounted on pallet hardpoints to define the vibration levels. An example is given in table C.1-2 for a piece of equipment attached to all 24 hardpoints of one pallet, with a total mass of 1000 kg. No excitation of the experiment itself through acoustic noise is assumed.

TABLE C.1-2. — RANDOM VIBRATION LEVEL FOR
PALLET HARDPOINT — MOUNTED EQUIPMENT

| Location | Frequency | Level |
|--|---------------|--------------------------|
| Pallet hardpoint mounted equipment mass = 1000 kg | 20 — 200 Hz | +8 dB/oct |
| | 200 — 700 Hz | 0.048 g ² /Hz |
| | 700 — 900 Hz | -18 dB/oct |
| | 900 — 2000 Hz | 0.011 g ² /Hz |
| | Composite | 6.8 g RMS |

The vibration environment exists for approximately 6 seconds per flight.

Note: The vibration environment is based on presently available data from the Orbiter and will be updated as test results of the Orbiter and Spacelab pallet structure become available.

1.2.2 ACOUSTIC

The acoustic sound pressure field inside the payload bay can be considered a reverberant one. The spectrum varies during launch with respect to level and shape. The maximum outer acoustic level occurs for a few seconds during main engine run up and launch. The time history of payload bay internal overall sound pressure level is given in paragraph 1.2.3, and in figure C.1-1. The spectrum shape for maximum outer acoustic level is given in figure C.1-2. All pallet-mounted equipment will be subjected to this acoustic noise environment.

1.2.3 ACOUSTIC VIBRATION

The estimated acoustic spectrum inside the cargo bay during launch is assumed to be the same for all pallet locations and is shown in figure C.1-1.

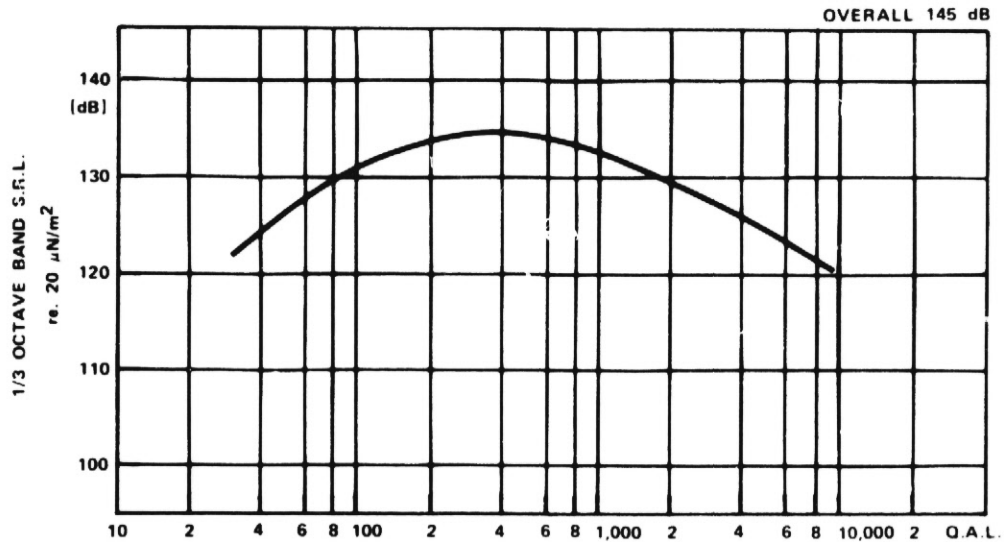

Figure C.1-1.— Analytical prediction of the Orbiter payload bay internal acoustic spectrum.

This spectrum produces an effective (integrated) overall sound pressure level of 145 dB as shown. The maximum acoustic level occurs at time of lift-off and decreases with time very rapidly as shown in figure C.1-2.

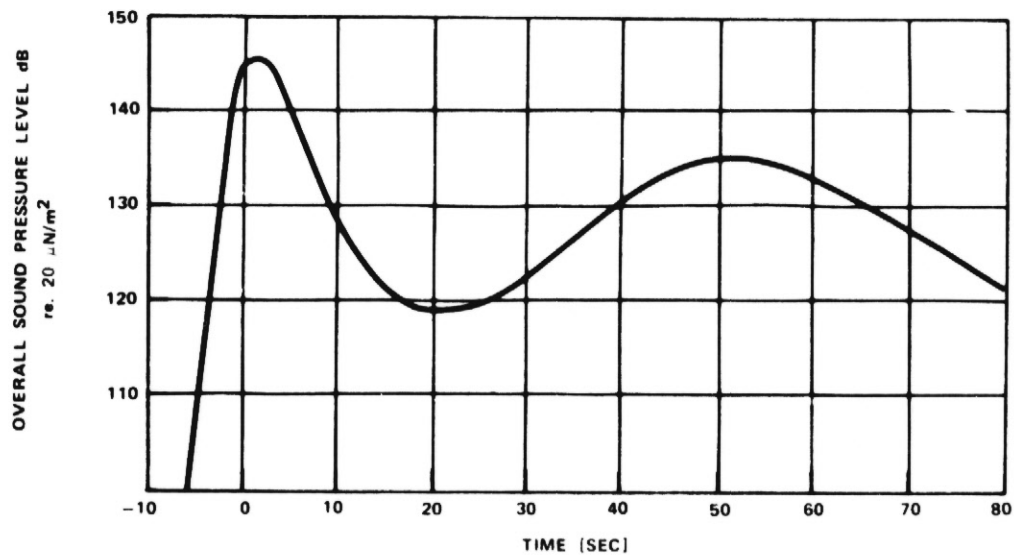

Figure C.1-2.— Orbiter payload bay internal acoustic time history.

1.2.4 SHOCK

1.2.4.1 Pyro Shock

TBD

1.2.4.2 Landing Shock

Rectangular pulses of the following peak accelerations will be defined in table C.1-3, which are generated by the Orbiter during landing operations.

TABLE C.1-3. - LANDING SHOCK

| Acceleration (g Peak) | Duration (Milliseconds) |
|--------------------------|----------------------------|
| 0.23 | 170 |
| 0.28 | 280 |
| 0.35 | 330 |
| 0.43 | 360 |
| 0.56 | 350 |
| 0.72 | 320 |
| 1.50 | 260 |

Considerations should be given to analyzing the landing shock environment in lieu of test since the "g" levels are relatively low in comparison to the bench handling shock.

1.2.4.3 Crash Safety Shock

In addition to static acceleration loads for crash landing, equipment has to be verified for crash safety shocks. The equipment design goal for crash safety shock should be based on a 40 g \pm 6 g sawtooth for an 11 millisecond duration. This requirement is currently under discussion.

1.2.4.4 Nonoperating Requirements

Equipment and structure attachments must be certified to withstand the crash safety shock without breaking loose and creating a hazard to personnel, or preventing egress from a crashed vehicle. This environment may be satisfied by the static structural stress analysis. Testing should only be performed on those items not covered in the stress analysis.

1.2.4.5 On-Orbit Operations

During missions in which EVA to the payload bay could occur as an emergency activity, the pallet-mounted equipment may be inadvertently kicked or pushed by the crew. The worst case for a kick-load by an EVA-suited crew member is (TBD) g (frequency range TBD) and for a push-off load of (TBD) g (steady state). Should EVA be required, the pallet-mounted equipment need only be capable of surviving these loads intact.

1.2.5 ACCELERATION

1.2.5.1 Nominal Mission/Emergency Sequence

Maximum steady state and low frequency (60 Hz) accelerations, to which the AMPS experiment equipment will be subjected during a nominal mission sequence, are given in table C.1-4. Equipment must be capable of normal operation after being subjected to acceleration for each of the mission events except for crash landing.

Payload equipment must be capable of surviving the crash landing acceleration loads with sufficient physical integrity to preclude hazards to the flight personnel after the application of crash loads.

ORIGINAL PAGE IS
OF POOR QUALITY

C.1-9

TABLE C.1-4. — DESIGN ACCELERATIONS FOR 32 K1b DOWN

| Mission Phase | Y-Direction | | Y-Direction | | Z-Direction | | Total Accelerations (Limit Load Factors) | | | | | |
|---|--------------|-----------------|--------------|-----------------|--------------|-----------------|--|------|------|------|-----|------|
| | Steady-state | Dynamic 0-60 Hz | Steady-state | Dynamic 0-60 Hz | Steady-state | Dynamic 0-60 Hz | +x | -x | +y | -y | +z | -z |
| Thrust Buildup Emergency Rebound | -1.0 | 0.5 | 0 | 0.3 | 0 | 0.3 | 0 | 1.5 | 1.5 | 0.3 | 0.3 | 0.3 |
| Launch Release | -1.5 | 1.0 | +0.1 | 0.7 | +0.1 | 2.9 | 0.4 | 3.4 | 0.8 | 0.8 | 3.0 | 3.0 |
| Max. Aerodynamic Resistance Phase | -2.0 | 0.3 | +0.6 | 0.3 | +0.8 | 0.3 | 0 | 2.3 | 0.9 | 9.0 | 1.1 | 1.1 |
| Max. Acceleration During Solid Rocket Motor Burn | -3.0 | 0.3 | +0.3 | 0.2 | +0.4 | 0.2 | 0 | 3.3 | 0.5 | 0.5 | 0.9 | 0.6 |
| Solid Rocket Motor Cut-Off-Separation | -1.0 | 3.0 | +0.1 | 0.3 | +0.3 | 0.5 | 2.0 | 4.0 | 0.4 | 0.4 | 0.3 | 0.8 |
| Max. Acceleration During Orbiter Only Boost Phase | 3.0 | 0.3 | +0.1 | 0.2 | -0.6 | 0.2 | 0 | 3.3 | 0.3 | 0.3 | 0 | 0.8 |
| Orbiter Boost Cut-Off/Separation | -0.1 | 2.0 | +0.1 | 0.3 | 0.2 | 0.4 | 1.9 | 2.1 | 0.4 | 0.4 | 0.6 | 0.2 |
| Re-Entry | +1.0 | 0.4 | +0.4 | 0.3 | 3.0 | 1.0 | 1.4 | 0 | 0.7 | 0.7 | 4.0 | 0 |
| Flyback | +0.3 | 0.3 | +0.2 | 0.1 | 1.0 | 0.4 | 0.6 | 0.6 | 0.3 | 0.3 | 1.4 | 0 |
| Landing, Taxying Braking | 1.0 | 0.3 | +0.1 | 0.2 | 2.0 | 1.0 | 1.3 | 0 | 0.3 | 0.3 | 3.0 | 0 |
| Crash Landing Loads | | | | | | | 9.0 | 1.5* | 1.5* | 1.5* | 4.5 | 2.0* |

*Superceded by misalignment of axial (9g) acceleration

Table C.1-4 presents estimated maximum steady state and dynamic accelerations acting on the payload center-of-gravity during the indicated mission phase. The dynamic accelerations are zero to peak values associated with frequencies from 0 to 60 Hz. The total accelerations represent limit load factors for the payload design which must be capable of withstanding all eight combinations for each mission phase (except for crash cases).

1.2.5.2 On-Orbit Maneuvers

During normal Orbiter attitude-control activities, thrusting of the Orbiter RCS will cause slight acceleration to be exerted on payload equipment depending on its location with respect to the center of rotation.

Values are given in table C.1-5 for the RCS thrusters. All three angular accelerations may occur simultaneously and the linear acceleration at any point of payload may be calculated based on the distance from the Orbiter's center-of-gravity. This location will vary to some extent with the particular payload weight distribution.

1.2.5.3 Orbit Atmospheric Accelerations

On-orbit acceleration levels resulting from atmospheric drag on the Orbiter while in a drift mode of operation are shown in figure C.1-3. Perturbations such as crew movement, venting, etc., would affect acceleration levels in this mode of operation.

TABLE C.1-5. — ORBITER RCS MAXIMUM ACCELERATION LEVELS

| Direction | (1) Translational, $\frac{m}{sec^2}$ (ft/sec ²) | | | | | (2) Rotational, degrees/sec ² | | | |
|----------------------------|--|------------------|------------------|-----------------|------------------|--|-------------------|-------------------|-----------------|
| | +x | -x | ±y | +z | -z | ± $\ddot{\phi}$ | + $\ddot{\theta}$ | - $\ddot{\theta}$ | ± $\ddot{\psi}$ |
| RCS System | | | | | | | | | |
| Large Thruster 900 LB | 0.235 (0.770) | 0.177 (0.580) | 0.287 (0.940) | 0.467 (1.53) | 0.433 (1.42) | 1.460 | 1.54 | 2.050 | 0.970 |
| Vernier Thrusters 25 LB | 0 | 0 | 0.003 (0.009) | 0 | 0.003 (0.001) | 0.032 | 0.026 | 0.022 | 0.023 |

The time history of the specified levels is (TBD).

(1) i.e., translational acceleration of the Orbiter's center of gravity.

(2) ϕ, θ and ψ are the Euler angles associated with the Orbiter Body Axis Coordinate System.

C.1-11

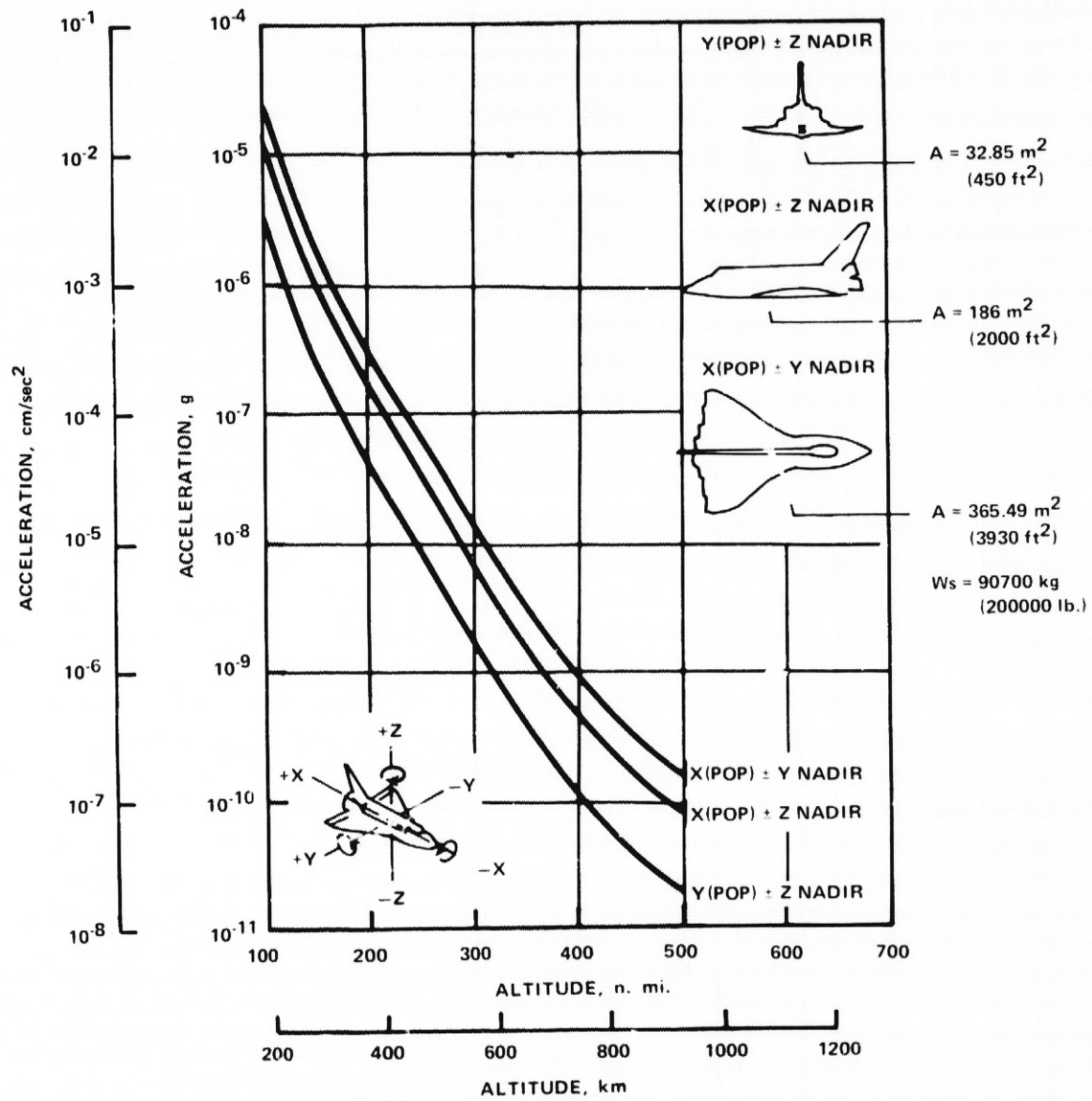

Figure C.1-3. - Effects of atmospheric drag on the Orbiter.

1.3 ELECTRICAL ENVIRONMENT

1.3.1 RADIATED EMISSIONS

Preliminary NASA-supplied estimates indicate that the Orbiter contribution to the payload electromagnetic environment will not exceed 0.5 V/m "across the spectrum" due to unintentional emissions.

Intentional emissions in excess of the above cited values are to be expected at the Orbiter S band transmission frequencies. Preliminary calculations show an expected level of approximately 3.4 V/m within the forward portion of the cargo bay, decreasing to 0.7 V/m in the aft section of the cargo bay. Pallet equipment may also be in the back-lobes or reflected signal paths of the various Orbiter rf transmitters. These are listed in table C.1-6 with their frequency characteristics, indicating the detailed payload interrogator frequencies used by the Orbiter.

Table C.1-7 shows the NASA-estimated worst case conditions for rf field coupling to harness wiring.

1.3.2 RADIATED RF SUSCEPTIBILITY

JSC Specification SR-ER-0004 requires that spacecraft equipment be tested in an rf field of at least 1 V/m over the frequency range of 14 KHz to 10 GHz. Similar test levels are recommended for payload equipment.

1.3.3 CONDUCTED EMISSIONS

1.3.3.1 Orbiter Emissions

NASA-supplied estimates indicate the following conducted interference levels on the primary power line interface (+ 28 Vdc nominal).

TABLE C.1-6. — ORBITER PAYLOAD INTERROGATOR TRANSMIT AND RECEIVE FREQUENCIES

| Channel | Transmit | Receive |
|---------|------------|------------|
| 1 | 2028.1 MHZ | 2202.5 MHZ |
| 2 | 2032.7 MHZ | 2207.5 MHZ |
| 3 | 2037.3 MHZ | 2212.5 MHZ |
| 4 | 2041.9 MHZ | 2217.5 MHZ |
| 5 | 2046.5 MHZ | 2222.5 MHZ |
| 6 | 2051.0 MHZ | 2227.5 MHZ |
| 7 | 2055.7 MHZ | 2232.5 MHZ |
| 8 | 2060.8 MHZ | 2237.5 MHZ |
| 9 | 2065.0 MHZ | 2242.5 MHZ |
| 10 | 2069.6 MHZ | 2247.5 MHZ |
| 11 | 2074.2 MHZ | 2252.5 MHZ |
| 12 | 2078.8 MHZ | 2257.5 MHZ |
| 13 | 2083.4 MHZ | 2262.5 MHZ |
| 14 | 2088.0 MHZ | 2267.5 MHZ |
| 15 | 2092.6 MHZ | 2272.5 MHZ |
| 16 | 2097.2 MHZ | 2277.5 MHZ |
| 17 | 2101.8 MHZ | 2282.5 MHZ |
| 18 | 2106.4 MHZ | 2287.5 MHZ |
| 19 | 2111.0 MHZ | 2292.5 MHZ |
| 20 | 2115.6 MHZ | 2297.5 MHZ |

TABLE C.1-7. -- ORBITER FREQUENCY UTILIZATION

| Equipment | Frequency |
|--------------------------------------|---|
| ATC Transceiver -- UHF | 259.7 MHz, 296.8 MHz & 243 MHz |
| EVA Transceiver -- UHF | 259.7 MHz, 279 MHz, 296.8 MHz |
| P/L Interrogator -- S Band S Band | 2202.5 -- 2297.5 MHz Receive 2028.1 -- 2115.6 MHz Transmit |
| STDN/TDRSS Transponder -- S Band | 2041.9 or 2106.4 MHz Receive |
| S Band | 2275 or 2287.5 MHz Transmit |
| Ku Band | 13.75 -- 13.8 GHz Receive (CF = 13.775 GHz) |
| Ku Band | 14.896 -- 15.121 GHz Transmit (CF = 15.0085 GHz) |
| FM Transmitter -- S Band | 2245 -- 2255 MHz (CF = 2250 MHz) |
| DFI FM Transmitter -- S Band | 2200 -- 2210 MHz (CF = 2205 MHz) |

- a. 1.8 volts peak-to-peak 30 Hz to 7 kHz, decreasing to 0.6 volts peak-to-peak at 50 kHz, then flat at 0.6 volts peak-to-peak at 50 kHz to 400 MHz
- b. ± 50 volts 10 μ sec spikes on dc powerline.

1.3.3.2 Pallet Emissions

Present limits on spacecraft-generated, conducted interference levels, as specified in greater detail in JSC Specification SR-ER-0004, include the following.

- a. 1.5 volts (rms) at any discrete frequency between 30 Hz and 3 kHz, and 1.5 volts (peak-to-peak) when measured in the frequency band extending from 3 kHz to 100 kHz.
- b. Primary bus transients measured on the positive lead of the 28 Vdc powerline will not exceed ± 28 volts and 50 μ sec in duration.
- c. Current rise and fall under load switching conditions will be as slow as practicable and will not exceed a rate of five amperes per microsecond.

1.3.3.3 Composite Environment

The composite conducted interference environment seen by the ASF payloads reflects the operation of the EPDS, i.e., dedicated operation with a fuel cell during normal on-orbit conditions, and non-dedicated fuel cell operation with Orbiter loads in parallel with ASF.

- a. Non-dedicated operation (ascent, power switchover, backup power operation, descent): power bus characteristics will be determined principally by the Orbiter emission levels.
- b. Dedicated operation: power bus characteristics will be determined principally by ASF emission levels.

1.3.3.4 Payload Emissions

It is recommended that ASF payloads comply with the design criteria and interference control requirements of JSC Specification SR-ER-0004 (which are based on the Space Shuttle Amendment to MIL-STD-461A).

1.3.4 CONDUCTED SUSCEPTIBILITY.

In order to assure compatible operation with the Orbiter (for equipment using primary power), it is recommended that payload equipment be qualified to the conducted susceptibility requirements of the Space Shuttle Amendment to MIL-STD-461A.

1.3.5 BONDING AND LIGHTNING PROTECTION

Structure or components that are in the main lightning current path (ref. JSC-07636, Space Shuttle Lightning Protection Criteria Document) will have a resistance of 2.5 milliohms or less and will be bonded to adjoining conducting members via a bond having a resistance of 2.5 milliohms or less.

Bonding of other metallic structures, such as equipment housing, etc., will follow the general guidelines of specification MIL-B-5087B, Bonding, Electrical and Lightning Protection, for Aerospace Systems, except that bonding requirements may be relaxed to a value of 10 milliohms, if equipment is not in the expected path of lightning discharge currents.

The experimenter is also cautioned to protect his externally interfacing input and output circuits against transients induced on signal and powerlines by the magnetic fields which accompany the lightning currents (ref. JSC-07636).

1.3.6 MAGNETIC ENVIRONMENT

Preliminary NASA-supplied estimates indicate that the Orbiter contribution to the payload magnetic environment will not exceed the following magnetic field levels:

dc Magnetic Field: (TBD)(not controlled by present specifications)

ac Magnetic Field: 120 dB above a picotesla at 30 Hz decreasing to 20 dB above a picotesla at 10 kHz

Note: The 400 Hz magnetic field level may exceed the above stated envelope.

1.3.6.1 Pallet Emissions

Spacecraft equipment magnetic field emission levels are controlled via paragraph 3.2.3.1.4 of JSC Specification SR-ER-0004, which limits the emissions over the frequency range of 20 Hz to 50 Hz to not more than 60 dB above a picotesla. In accordance with specifications, no requirements have been imposed to control magnetic fields below 30 Hz. However, the project is studying the impact on the program of minimizing the amount of magnetic materials and number of current loops in the design of spacecraft including equipment furnished on the pallets. The conclusions of this study and the resulting actions will be available in the near future.

1.3.6.2 Composite Environment

In estimating the magnetic field environment for spacecraft payload equipment, it must first of all be recognized that the magnetic field emission limits for onboard equipment are set for a measurement distance of one meter.

On the basis of the previous considerations, it is recommended that payload equipment be designed to operate in the following ac magnetic field environment; 120 dB above a picotesla at

30 Hz decreasing at a rate of 6 dB/octave to 80 dB above a picotesla at 3 kHz, and maintaining that value to 50 kHz.

1.3.6.3 Payload Emissions

It is recommended that payload equipment forseen for ASF use as pallet-mounted equipment does not exceed a radiated magnetic field level of 60 dB above one picotesla over the frequency range of 30 Hz to at least 50 kHz.

No specific susceptibility requirements have been imposed on Orbiter equipment. Spacecraft equipment on the pallets must not malfunction in a 80 dB pT field, 30 Hz to 30 kHz.

1.4 RADIATION AND METEORIDS ENVIRONMENT

The actual radiation levels that a given piece of equipment will encounter will depend on the mission profile and on the stopping power of the material surrounding the equipment.

Equipment requiring stowage in very low radiation environments must be equipped with the necessary shielding to provide the required environments.

1.4.1 SOLAR RADIATION - (NUCLEAR)

The natural nuclear radiation environment in terrestrial space consists of; (1) galactic cosmic radiation, (2) geomagnetically trapped radiation, and (3) solar flare particle events.

1.4.2 GALACTIC COSMIC RADIATION - (MAINLY PROTONS)

Composition: 85 percent protons, 13 percent alpha particles, 2 percent heavier nuclei.

Energy Range: 10^7 to 10^{19} electron volts; predominant 10^9 to 10^{13} .

Flux outside Earth's magnetic field; 0.2 to 0.4 particles/cm²/steradian/sec.

Integrated yearly rate; Approximately 1×10^8 protons per sq cm.

Integrated yearly dose: Approximately 4 to 10 rads.

1.4.3 TRAPPED RADIATION - (PROTONS, ELECTRONS)

Energy: Electrons >0.5 MeV, Protons >34 MeV (omnidirectional).

Peak Electron Flux: 10^8 electrons per sq cm per sec (omnidirectional).

Peak Electron Flux Altitude: Approximately 1850 km at equator.

Peak Proton Flux: 10^4 to 10^5 protons per sq cm per sec (omnidirectional).

Peak Proton Flux Altitude: Approximately 3520 km at equator.

1.4.4 SOLAR PARTICLE EVENTS

Composition: Energetic protons and alpha particles.

Occurrence: Sporadically and lasting for several days

$$\text{Protons: } N_p(>T) = \begin{cases} 7.25 \times 10^{11} T^{-1.2} & 1 \text{ MeV} \leq T \leq 10 \text{ MeV} \\ 3.54 \times 10^{11} \epsilon \frac{P(T)}{67} & 10 \text{ MeV} \leq T \leq 30 \text{ MeV} \\ 2.6 \times 10^{11} \epsilon \frac{P(T)}{73} & T \geq 30 \text{ MeV} \end{cases}$$

$$\text{Alphas: } N_\alpha(>T) = N_p(>T) \quad \begin{matrix} T \leq 30 \text{ MeV} \\ T \geq 30 \text{ MeV} \end{matrix}$$

$$= 7.07 \times 10^{12} T^{-2.14} \quad T \geq 30 \text{ MeV}$$

Where $N_p(>T)$, $N_\alpha(>T)$ = protons/cm², alphas/cm² with energy $\geq T$

$P(T)$ = particle magnetic rigidity in mV

$$P(T) = \frac{1}{Ze} \{T(T + 2m c^2)\}^{\frac{1}{2}}$$

Ze = 1 for protons, 2 for alphas

$m c^2$ = 938 MeV for protons, 3728 MeV for alphas

e = Base of natural logarithms = 2.7183

For near-earth orbital altitudes the above free-space event model must be modified since the earth's magnetic field deflects some of the low-energy particles that would enter the atmosphere at low latitudes to the poles.

The meteoroid model encompasses particles of cometary origin in the mass range between 1 and 10^{-12} grams for sporadic meteoroids and 1 to 10^{-6} grams for stream meteoroids.

Average Total Environment:

Particle Density 0.5 g/cm³

Particle Velocity (average) 20 km/sec

Flux Mass Models:

a. For $10^{-6} \leq m \leq 1$ $\log N_t = -14.37 - 1.213 \log m$

b. For $10^{-12} \leq m \leq 10^{-6}$ $\log N_t = -14.339 - 1.584 \log m - 0.063 (\log m)^2$

N_t - no. particles/m²/sec of mass m or greater

m = mass in grams

Defocussing factor for earth and, if applicable, shielding factor are to be applied.

This model is only applicable if and when the payload doors are open and the equipment is exposed to space.

1.5 THERMAL ENVIRONMENT

The determination of the temperature environments which the payload will actually experience in the payload bay requires knowledge of the specific mission environment from boost through entry, the type of thermal control provided by the Orbiter and the payload, and the payload bay and payload thermal characteristics. To obtain this information requires detailed knowledge of the actual Orbiter and payload design, as well as the specific inflight orientations which probably will vary for each different mission objective. To initiate the thermal design and integration, the following data should be used as a guide and should be followed by detailed analysis as required.

While the Orbiter payload bay doors are closed, the radiative coupling with pallet equipment is dependent on the inside door surface characteristics and temperature which in turn are determined by the attitude mode of the Orbiter. The inside door surfaces have an emissivity (TBD) and the estimated surface temperatures for various modes are given in table C.1-8.

The maximum allowable heat rejection rate from a payload to the Orbiter structure, with the payload bay doors closed, during various attitude modes is still to be defined.

TABLE C.1-8. - ORBITER PAYLOAD BAY WALL TEMPERATURE

| Condition | Design Minimum | Design Maximum |
|---------------------------------|-----------------|------------------|
| Prelaunch | +4,5°C (+40° F) | +49°C (+120°F) |
| Launch | +4,5°C (+40° F) | +65,5°C (+150°F) |
| On-Orbit (Doors Closed) | See C & D | See A & B |
| Entry and Postlanding | -73°C (-100°F) | +93,5°C (+200°F) |
| <u>Heat Leak Criteria:</u> | | |
| A. Total Bay Heat Gain, Average | (TBD) | |
| B. Heat Gain, Local Area | (TBD) | |
| C. Total Bay Heat Loss, Average | (TBD) | |
| D. Heat Loss, Local Area | (TBD) | |

1.5.1 SPACE ENVIRONMENT

With the payload bay doors open, the thermal radiative environment for pallet-mounted equipment is determined by the incoming fluxes given in table C.1-9, the Orbiter attitude, and the equipment shadow/illumination configuration.

TABLE C.1-9. - SPACE THERMAL ENVIRONMENT

| Environmental Parameter | Unit | Maximum | Nominal | Minimum |
|-------------------------|---|-----------------|-----------------|-----------------|
| Solar Radiation | W/m ² (Btu/hr-ft ²) | 1440.5 (457) | 1352.2 (429) | 1264.0 (401) |
| Earth Global Albedo | Percent (%) of Solar Radiation | 42 | 30 | 18 |
| Earth Thermal Radiation | W/m ² (Btu/hr-ft ²) | 278.6 (88.4) | 236.4 (75.0) | 194.2 (61.6) |
| Space Sink Temperature | Kelvin | - | 2.7 K | - |

1.5.2 ATMOSPHERE

1.5.2.1 Launch Sequence

The Orbiter payload bay is vented during the launch and entry phases and operates unpressurized during the orbital phase of the mission. Figure C.1-4 defines the payload bay pressure history during ascent.

Note: This is preliminary data. Details considering the effect of ASF volume are (TBD).

1.5.2.2 On-Orbit

A pressure of 1.33×10^{-14} bar (1.93×10^{-13} psia) will be the design consideration. Other values are given in table C.1-10.

TABLE C.1-10. — ATMOSPHERIC PRESSURE

| Altitude | Max P (bar) | Min P (bar) |
|----------|---|-----------------------|
| 81 km | 1.8×10^{-8} | 1.06×10^{-8} |
| 115 km | 2.9×10^{-9} | 6.3×10^{-10} |
| 575 km | 2.9×10^{-12} | 6.3×10^{-14} |
| 1,380 km | Approx. 1.33×10^{-14} in either case | |

1.5.2.3 Re-entry Sequence

During re-entry and landing the payload bay pressure will be increased to the landing site pressure by using filtered atmospheric air (50 microns absolute). Figure C.1-5 defines the payload bay pressure history during re-entry.

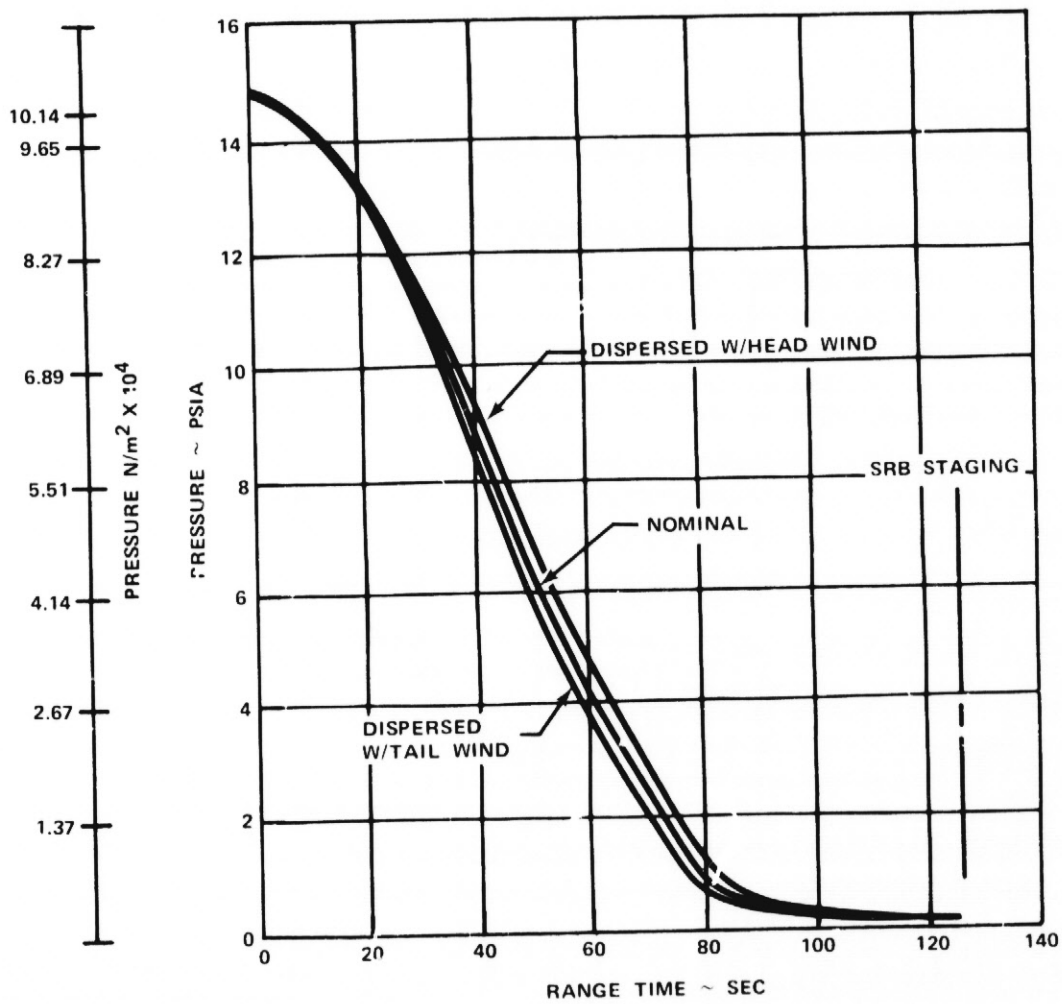
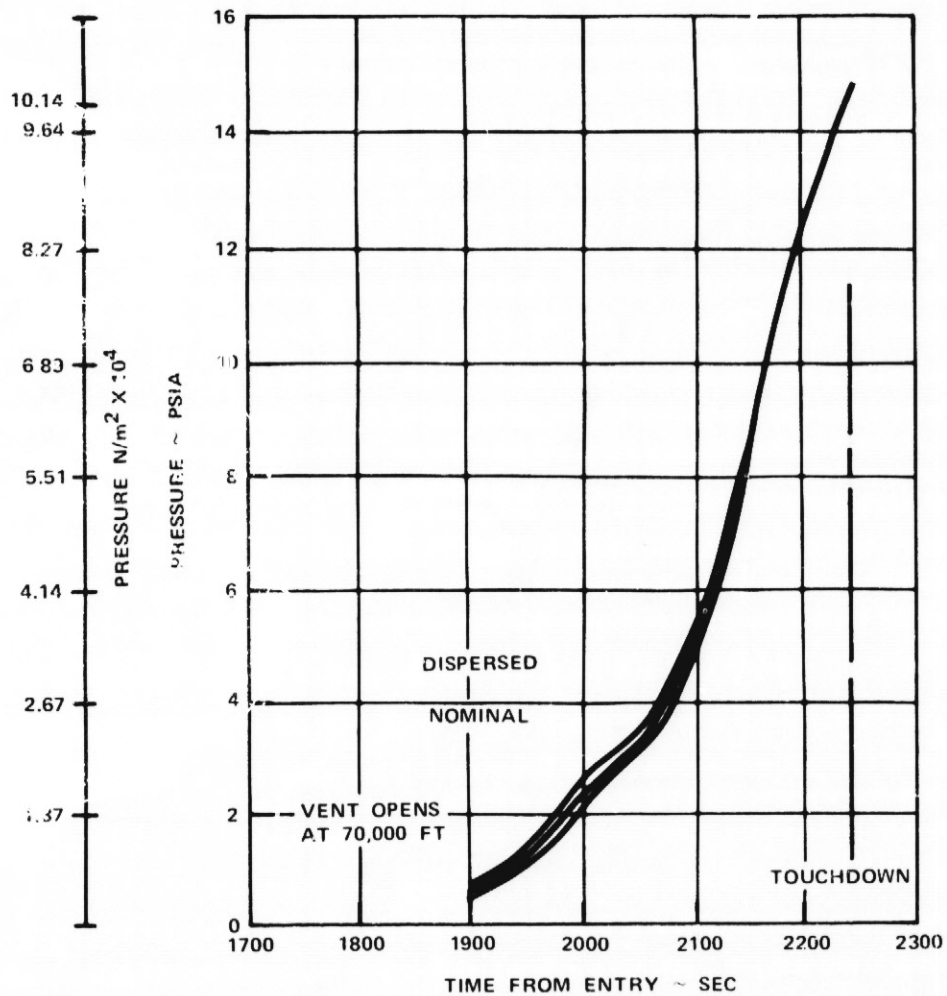

Figure C.1-4.— Orbiter payload bay internal pressure histories during ascent.



Note: Figure C.1-5 is preliminary data. Details considering the actual effect of ASF volume are (TBD).

Figure C.1-5.— Orbiter payload bay internal pressure histories during entry.

APPENDIX C.2
ENVIRONMENTAL ANALYSES

CONTENTS

| Section | Page |
|--|--------|
| 1.0 ELECTROMAGNETIC INTERFERENCE (EMI). | C.2-1 |
| 1.1 <u>ELECTROMAGNETIC COMPATIBILITY (EMC)</u> | C.2-1 |
| 1.2 <u>EMI CHARACTERISTICS OF ASF INSTRUMENTS</u> | C.2-3 |
| 1.2.1 AIRGLOW SPECTROGRAPH, INSTRUMENT 116. | C.2-3 |
| 1.2.2 LIMB SCANNING IR RADIOMETER, INSTRUMENT 118 | C.2-3 |
| 1.2.3 FABRY-PEROT INTERFEROMETER, INSTRUMENT 124 | C.2-5 |
| 1.2.4 LASER SOUNDER, INSTRUMENT 213 | C.2-5 |
| 1.2.5 ELECTRON ACCELERATOR, INSTRUMENT 303. | C.2-5 |
| 1.2.6 MAGNETOPLASMA DYNAMIC ARC, INSTRUMENT 304 | C.2-6 |
| 1.2.7 GAS RELEASE MODULE, INSTRUMENT 532. | C.2-6 |
| 1.2.8 TRIAXIAL FLUXGATE, INSTRUMENT 536 | C.2-6 |
| 1.2.9 FARADAY CUP, RPA, COLD PLASMA PROBE INSTRUMENT 550. | C.2-6 |
| 1.2.10 ULTRAVIOLET OCCULTATION SPECTROGRAPH. | C.2-7 |
| 1.3 <u>ELECTROMAGNETIC INTERFERENCE CONTROLS</u> | C.2-7 |
| 2.0 DUST, GAS, PARTICULATE CONTAMINATION. | C.2-9 |
| 2.1 <u>INTRODUCTION</u> | C.2-9 |
| 2.2 <u>ORBITER BORNE SENSOR CONTAMINATION</u> | C.2-9 |
| 2.2.1 TYPICAL CONTAMINATION PROBLEMS. | C.2-13 |
| 2.2.2 EFFECTS | C.2-15 |

FIGURES

| Figure | Page |
|---|--------|
| C.2-1 Condensible deposition versus time. | C.2-17 |

TABLES

| Table | Page |
|--|--------|
| C.2-1 ASF INSTRUMENTS SUSCEPTIBLE TO AND GENERATORS OF EMI | C.2-4 |
| C.2-2 POTENTIAL CONTAMINATION SOURCES | C.2-10 |
| C.2-3 ORBITER EFFLUENT DISCHARGE. | C.2-12 |
| C.2-4 POTENTIAL SENSOR PERFORMANCE DEGRADATION VERSUS SPECTRAL REGION | C.2-18 |

1.0 ELECTROMAGNETIC INTERFERENCE (EMI)

1.1 ELECTROMAGNETIC COMPATIBILITY (EMC)

EMC will be of major concern to the ASF (and AMPS) program. The experiments on these programs require a large number of extremely sensitive instruments, many of which are substantial generators themselves of EMI. For the pallet-only mode, these instruments are installed compactly on pallets within the confines of the Orbiter payload bay. In addition, the background EMI generated by the Orbiter will add significantly to that generated by the instruments and the ASF support subsystems. The Orbiter, having a metal frame with dc power return through the structure (variable current of 400 to 500 amperes) produces variable magnetic fields which will interact with the earth's magnetic field in an unpredictable fashion.

Charged particles spiraling along magnetic flux lines will have a wide range of path instantaneous radii varying from μm to meters and being dependent upon the particle initial velocity and incident angle. Therefore, particle detection will be influenced by Orbiter orientation and magnetic mass out to several orbit diameters away. The amount of the error is dependent upon so many interrelated parameters that only a rather complete investigation will determine this answer.

In addition to the radiated, conducted, and magnetic field generation and susceptibility characteristics of ASF instruments, the electrostatic charge buildup of the Orbiter and payload structure relative to the plasma in the vicinity of the Orbiter can be a major problem area. Instruments such as the Electron Accelerator and the Magnetoplasma dynamic Arc require the ejection of charged particles away from the Orbiter and payload. Large electrical potentials between the Orbiter or payload and the adjacent plasma could reduce the velocity of the ejected particles to an unacceptable level.

Safety of the Orbiter crew and vehicle will be of major concern in establishing generated interference requirements and in controlling ASF payload EMI levels. Areas of concern include real time effects of ASF generated EMI on ordinances, vehicle control and stabilization, communication, guidance, navigation, life support systems and permanent or undetected effects on equipment and software programs.

In addition to EMI, the buildup of electrostatic charge on the Orbiter and payload structure relative to the electron or ion plasma in the Orbiter vicinity can be a major problem. Large potentials between the vehicle structure and the plasma could prevent accelerated particles from traveling the distance from the Orbiter required of the experiment or could reduce particle velocity to an unacceptable level.

This section discusses the EMI characteristics of some of the scientific instruments which may require special attention during the design and test phase, the techniques available to minimize generation of and susceptibility to EMI, and identifies areas requiring further study.

In order to minimize the possibility of encountering EMC problems during the design phase, certain guidelines have been established by the Government and the aerospace industry.

Some of these basic guidelines to be followed in developing the EMC approach for this program are.

- a. Control of design and operations will be in accordance with Space Shuttle Program Specification SL-E0001A (modified MIL-I-6051D).
- b. Single point grounding for each primary power system will be utilized within the ASF/AMPS payload.

- c. The single point ASF/AMPS returns and powerlines will be routed to the Orbiter primary power sources using twisted shielded wire pairs, triads, etc. Payload and Orbiter structure will not be used as a primary return path for payload power.
- d. Separate primary power circuits and returns from central payload power buses will be provided for each instrument to minimize common impedances.

1.2 EMI CHARACTERISTICS OF ASF INSTRUMENTS

Assessment of the characteristics of existing and proposed instruments indicates that certain categories of instruments have greater sensitivity to generated interference than others because of the nature of the instruments. It is also apparent that certain instruments are major generators of EMI because of the use of high energy levels and methods of operation. Table C.2-1 lists the ASF instruments expected to have the greatest sensitivity to EMI and those which generate significant levels of interference.

1.2.1 AIRGLOW SPECTROGRAPH, INSTRUMENT 116

The Airglow Spectrograph is susceptible to extraneous fluctuating and static levels of magnetic fields. The sensitivity of the image intensifier can be degraded when exposed to magnetic field levels greater than 1 gauss at the image intensifier. The image intensifier is also a generator of magnetic fields which can affect operation of other instruments. The fields are generated by the focusing coils at intensity levels of up to 65 gauss at the coils.

1.2.2 LIMB SCANNING IR RADIOMETER, INSTRUMENT 118

The Limb Scanning IR Radiometer utilizes 12 gold or copper-doped germanium detectors. These detectors are susceptible

TABLE C.2-1

ASF INSTRUMENTS SUSCEPTIBLE TO AND GENERATORS OF EMI

| Instruments | Electromagnetic Interference (EMI) | | | |
|--|------------------------------------|--|-----------------|----------------------|
| | Radiated/Conducted | | Magnetic Field | |
| | Susceptible To | Generator Of | Susceptible To: | Generator Of: |
| 116 Airglow Spectrograph - Image Intensifier | -- | Radiated Broadband (≤ 25 kV) | 1 gauss | <65 gauss |
| 118 Limb Scanning IR Radiometer - Detector Circuit | Radiated 0 to 20 kHz | -- | -- | -- |
| 124 Fabry-Perot Interferometer - Photomultiplier | -- | -- | 1 gauss | -- |
| 213 Laser Sounder - Optical Pump (pulsed) | -- | Radiated Broadband (~ 50 kV) | -- | (~ 10 K amps) |
| Input Power Leads | -- | Conducted | -- | -- |
| 303 Electron Accelerator - Accelerator System (pulsed) | -- | Radiated Broadband (~ 30 kV) | -- | (~ 7 amps) |
| Input Power Leads | -- | Conducted | -- | -- |
| 304 Magnetoplasmadynamic Arc- Arc Generator | -- | Radiated Broadband (~ 5 kV) | -- | (~ 200 K amps) |
| Input Power Leads | -- | Conducted | -- | -- |
| 532 Gas Release Module - Photomultiplier | -- | -- | 1 gauss | 20 - 40 gauss |
| Quadrupole Mass Filter | -- | Radiated 2 to 10 MHz | -- | -- |
| 536 Triaxial Fluxgate - Pickup Coils | -- | -- | 10 gammas | -- |
| Modulator Coils | Radiated 10 Hz | -- | -- | -- |
| 550 Faraday Cup, Retarding Potential Analyzer, Cold Plasma Probe - Electrometer | Radiated Low Frequency | -- | -- | -- |
| 1011 Ultraviolet Occultation Spectrograph - Image Intensifier | -- | -- | 1 gauss | 20 - 40 gauss |

**ORIGINAL PAGE IS
OF POOR QUALITY**

to extraneous radio frequency (rf) noise in the low frequency to 20 kHz range. Noise degrades the quality of the detector output signal.

1.2.3 FABRY-PEROT INTERFEROMETER, INSTRUMENT 124

The Fabry-Perot Interferometer utilizes photomultiplier tubes. The focusing of the electrons coming off the cathode can be affected by extraneous magnetic fields of the level of 1 gauss or greater at the tube.

1.2.4 LASER SOUNDER, INSTRUMENT 213

The Laser Sounder operates in a pulsed radar-like mode. The optical pump (or pump lamp) is pulsed with a voltage of up to 50 K volts to excite the beam. Broadband rf can be generated by the switching of the high voltage, and magnetic fields are generated because of the high currents (up to 10 K amps) required. The high voltage is accumulated in a bank of capacitors which are charged through heavy input power filters to reduce the conductive interference generated on the input powerlines. The level and frequency of this interference depends on the discharge rate of and current amplitude from the capacitor bank.

1.2.5 ELECTRON ACCELERATOR, INSTRUMENT 303

The Electron Accelerator can be operated in a dc pulsed or modulated mode. The switching of the high voltage (up to 30 kV) used to accelerate the electrons will create a broadband rf interference level. The electron current will generate a magnetic field which can affect other instruments in the near vicinity. The high voltage used to accelerate the electrons is generated using power converters and a large bank of capacitors. The level of the conducted interference generated on the input power leads depends on the switching rate and the amplitude of the discharged current.

1.2.6 MAGNETOPLASMADYNAMIC ARC, INSTRUMENT 304

The Magnetoplasmadynamic Arc operates in a pulsed mode. A gas is admitted into the instrument discharge region and when a predetermined pressure is reached, a high voltage is applied to the instrument cathode which causes a high intensity breakdown of the gas. During the breakdown of the gas, the voltage reduces to a lower level (<100 volts) but the discharge current increases to many thousands of amperes. The voltage breakdown will generate a broadband rf interference and the large current sustaining the arc will generate a magnetic field. The high voltage is generated in the same way described for the operation of Instrument 303 and conducted interference will be generated on the input power leads.

1.2.7 GAS RELEASE MODULE, INSTRUMENT 532

The Gas Release Module uses photomultipliers and will be susceptible to the same level of extraneous magnetic field as in the Fabry-Perot Interferometer (>1 gauss). It also uses a quadrupole mass filter to screen the electrons being expelled. The filter will generate rf in the 2 to 10 MHz range.

1.2.8 TRIAXIAL FLUXGATE, INSTRUMENT 536

The Triaxial Fluxgate will be susceptible to extraneous interference which disturbs the ac signal used to modulate the fluxgate. The distortion of the modulating signal can result in an extraneous output reducing the accuracy of the actual measurement. Due to the nature of the instrument, the fluxgate is susceptible to extraneous magnetic fields. For the instrument mounted on the pallet, extraneous fields up to 10 gammas at the instrument can probably be tolerated.

1.2.9 FARADAY CUP, RPA, COLD PLASMA PROBE, INSTRUMENT 550

Instrument 550 is made up of the Faraday Cup, the Retarding Potential Analyzer, and the Cold Plasma Probe. The electrometer used in the

Faraday Cup is sensitive to very low currents and low frequency rf interference can affect the accuracy of current measurements.

1.2.10 ULTRAVIOLET OCCULTATION SPECTROGRAPH

The Ultraviolet Occultation Spectrograph uses an image intensifier similar in function to that used on Instrument 116 (Airglow Spectrograph). However, the voltage used for focusing is of the order of 100 volts and the generated rf levels will not be significant. The image intensifier is, however, a generator of magnetic field interference of the level of 20 to 40 gauss at the focusing coil. The image intensifier for this instrument is susceptible to extraneous magnetic fields of the same levels as those affecting the Airglow Spectrograph (1 gauss at the coils).

A treatment of contamination characteristics of all AMPS (including ASF) instruments is contained in appendix C-3, Interference Problems For AMPS Instruments.

1.3 ELECTROMAGNETIC INTERFERENCE CONTROLS

The EMI aspects identified in table C.2-1 can probably be controlled in each case using conventional techniques. The radiated rf generated interference effects can be minimized through the use of shielding, filtering and, when possible, reducing the rise and fall times of pulses. Susceptibility to radiated rf can be minimized by shielding, minimizing power circuit non-linearities such as rectification, and by increasing sensitivity thresholds.

Conducted interference generation can be minimized by heavy filtering of input powerlines, by reducing the frequency and amplitude of current demand, and by reducing common impedances. Susceptibility to generated conducted interference can be

minimized through input power filtering, common mode rejection (e.g., use of differential amplifiers) and increasing threshold levels.

Effects of generated magnetic fields can be minimized through the use of mu-metal and other high permeability metal shields. Magnetic field generation can be reduced by decreasing the total area covered by current loops. Twisting together lines carrying the same current inbound to, and outbound from, a high level load is universally used to reduce current loop area. Susceptibility to magnetic field interference can be accomplished using the same techniques used to reduce the effect of generated magnetic field interference.

The need for controlling the electrostatic potential between the Orbiter and payload structure and the plasma and the methods for control are still to be evaluated. Some means of providing a discharge path between the Orbiter and the plasma such as extended structures or plasma sheaths might be required.

2.0 DUST, GAS, PARTICULATE CONTAMINATION

2.1 INTRODUCTION

Of the almost 60 ASF/AMFS experiments, most of the sensors will be affected in one way or another by unavoidable Orbiter characteristics. These include: floating particles, water vapor and gas contamination, potential differences between the sensor and Orbiter and earth magnetic flux distortions. Table C.2-2 indicates the basic contamination sources.

Considerable evidence reviewed indicates that outgassing from the spacecraft materials is one of the primary causes of degraded performance of satellite-borne optical instrumentation. Other interesting examples of this phenomenon are contained in other references. It has been shown in these references that the most common of these contaminants, the high molecular weight organic materials, are quite transparent prior to solar photolysis and cannot be detected by routine transmittance measurements. Exposure to energetic photons and electrons creates products which strongly absorb the short wavelength (ultraviolet) radiation.

To develop an indication regarding the number of sensors affected by each of the sensors of contamination producing signal degradation, each contamination aspect described will be identified in this section and a summary chart used to indicate the sensors affected. Determination of the degree of error can be estimated but only extensive analysis will produce a rigorous answer.

2.2 ORBITER BORNE SENSOR CONTAMINATION

There are a number of potential Orbiter sources which could and will produce sensor signal degradation. These include not only optic contamination due to deposits, but also signal degradation

TABLE C.2-2. - POTENTIAL CONTAMINATION SOURCES

| Mission Phase | Payload Effluent | Stage Effluent | Shuttle Effluents | | | | | |
|----------------|-----------------------------|--|---|------------------------------------|--|---|-------------------|--|
| | | | RCS Flume | CMS Flume | Leakage | EC/LS Effluent | Fuel Cell Purge | Ablator Outgassing |
| Prelaunch | Leakage | Possible Vent Leakage | N/A | N/A | N/A | Leakage | N/A | N/A |
| Launch Pad | Leakage | Vent Leakage | N/A | N/A-Even if CMS used P/L protected | Possible CMS or Ablator Contaminants | Leakage | N/A | Outgassing will not affect P/L |
| Orbit Open | Leakage/Outgassing | Vent Leakage | N/A as long as P/L is not erected | Same as RCS | See Above | Leakage/Waste no problem unless hold tanks full | See Table C.2-3 | Outgassing expected to last only 14 hours at significant level |
| P/L Deployment | Leakage/Outgassing | Vent Leakage | N/A-Inhibited during deployment | N/A-not used at this time | See Table 5.2.2-1 and above | See Table 5.2.2.1 | See Table 5.2.2.1 | See Above |
| Separation | Leakage/Outgassing | Vent Leakage | N ₂ , H ₂ , NH ₃ | N/A-see above | See above | See above | See above | See above |
| Loiter | Leakage/Outgassing | Vent Leakage | N/A-Distance | N/A-see above | N/A-Distance | N/A-Distance | N/A-Distance | N/A-Distance |
| Service | Leakage | Vent Leakage | N ₂ , H ₂ , NH ₃ | N/A | See table C.2-3 and Ablator contaminants | See Table 5.2.2-1 | See Table 5.2.2-1 | Unknown |
| Service | Dust, Dirt particles in Bay | Outgassing transplant or electrostatic transport | | | | | | |

ORIGINAL PAGE IS
OF POOR QUALITY

C.2-10

because of the Orbiter magnetic or electromagnetic characteristics. Line-of-sight observation in various spectral regions due to gas and particle radiation scattering, reflection, absorption and reradiation, may also be a real problem with many low radiation level sensors to be used in the ASF/AMPS program.

Table C.2-3 lists the more obvious contaminants originating from the Orbiter. Since many of these potential signal degrading characteristics are inherent in the Orbiter design, about the only solution is to deploy the sensors sensitive to these various signal degradations to some position remote from the Orbiter vehicle. This was attempted during this conceptual study. Two booms plus a PDS are incorporated into the ASF concept.

A basic problem with the remote sensor deployment is that the remote platform (subsatellite or boom) must be designed to eliminate the adverse Orbiter characteristics or no real advantage will be produced. To date, in satellites such as the AE, this has not been one of the basic design features because there was plenty of time available for equilibrium conditions to be established (two or more weeks). Basic Orbiter goals make time one of the most critical factors in its cost effectiveness.

In addition, the larger payload capacity of the Orbiter permits the design and use of much more sensitive sensors. In many cases these sensor systems will be capable of measuring the supporting platform influences as well as the desired phenomena. It will be exceedingly difficult and costly to separate the two effects in the data analysis.

TABLE C.2-3. - ORBITER EFFLUENT DISCHARGE

| Source | Effluent | Date | Occurrence |
|--|---|---|--|
| Leakage Hatch Avionics Bay | O ₂ , N ₂ O ₂ , N ₂ and Potential Equipment Outgassings | ~0 to 3.5 lb/day ~0 to 400 STD. CC/HR | Continuous Continuous |
| EC/LS Effluent Waste (Fecal) Management Ullage | H ₂ O N ₂ , O ₂ Atmosphere and Methane | 0.02 lb/man-day 0.01 lb/cycle | Ejected in Sealed Bags at Selected Intervals 2 cycles/man-day |
| Fuel Cell Purge O ₂ Purge | O ₂ A N ₂ H ₂ O CO ₂ , Hydrocarbons | 0.03 - 0.07 lb 0.013 - 0.016 lb 0.01 lb 0.002 - 0.0075 lb Trace | Once per hour |
| Ablator | Large Carbon-Silica Molecules and Hydro- carbon Gases | Approximately 0.5 to 2 lb After In- sertion | Each mission; Exponentially Decays; Approx. 90% Com- plete 24 hrs. After Insertion |
| Equipment Cooling Water From Flash Evaporator | H ₂ O | Supersonic Nozzle Intermittant (Maxi- mum) Rate 30 lb/hr) | On Demand - Every Few Minutes When High Heat Load Present |
| Orientation Jets | Range of Propellant Gasses | Random Rates Up to Several lbs/hr. | Intermittant Every Few Minutes Payload Distri- bution Dependent |

2.2.1 TYPICAL CONTAMINATION PROBLEMS

The Orbiter contamination problems are complete different from any of those which have been present in past satellite work. The Skylab had considerable time in space to outgas. Most of the sensors were inside, or partly inside, looking out of the pressurized capsule. Dedicated satellites also are given time in space before they are used so that all of the systems can come to an equilibrium.

However, the constant loading and unloading of Orbiter every few weeks with no more than 1 to 3 weeks in space makes it almost impossible to even estimate the extent of the pollution problem which from previous experience must be present. There will be a wide variety of users, each responsible for only his sensor operation. The pressurized pallets, entrance ducts, and pressurized sensor packages will all contribute a steady flow of gas, water vapor and space-polluting material.

Sensor contamination generally occurs through deposits on optics and transmitting materials in the sensor housing. The large quantities of water vapor ejected in equipment cooling and frequent pulsing of thrust jets at both ends of the Orbiter to maintain orientation will produce part of the surface contamination. This contamination is able to enter the open sensor compartment by reflection from surfaces or by multiple impacts in the gas cloud surrounding the Orbiter.

An equally large source of contamination will be from outgassing and leakage from the crew quarters and from pressurized sensor systems in the Orbiter bay area.

All of the above considerations will produce line-of-sight radiation attenuation, scattering, and remission. The effect will be radiation wavelength, material concentration, and

composition dependent. It will also be time dependent, and measurements made in actual operation are required to determine the severity of the situation.

Another consideration concerning ultraviolet optics is that a very thin deposit of complex molecules such as oils, grease, or polymers, when struck by solar ultraviolet radiation, quickly become opaque at short wavelengths. This has been very well documented for LANDSAT I and other satellites. The radiation attenuation usually is adequate to render the data useless.

In the infrared, the presence of even a very diffuse cloud containing water vapor, and carbon dioxide, and carbon monoxide will cause extensive narrow and wide spectral band radiation absorption.

Other sensor signal degrading contaminants include O_3 which is present in the upper atmosphere and frequently becomes trapped in existing space vehicles. This highly active oxygen reacts with ultraviolet transmitting optics forming a radiation filtering material.

2.2.2 EFFECTS

Many of the sensors to be flown in the AMPS program will have 10,000 class cleanliness requirements. This environment will not be guaranteed by the Orbiter system; thus, we must consider the possible effects. Two effects are of major concern. One is the condensation of contaminants on optical surfaces. Condensation of contaminants on optical surfaces may be caused by direct (line-of-sight) impingement or indirect (reflected) impingement, either while in the Orbiter bay or during the process of deployment and checkout with the Orbiter.

Another effect is excessive uncontrollable sensor signal degradation due to contamination from one of many of the following.

- a. Magnetic field deformation due to the Orbiter's physical characteristics.
- b. Particle generation by Orbiter due to loose material in hold. Particles will have a wide range of:
 - (1) Sizes and material characteristics
 - (2) Charges and velocities in random directions
 - (3) Effects on each of the various types of sensors.
- c. Gas emission by Orbiter due to cooling water ejection, orientation jets, gas release experiments, and gas leakage from pressurized compartments. This will produce a perpetual gas cloud around the Orbiter and will:
 - (1) Attenuate the incoming radiation in a spectrally selective manner.
 - (2) Attenuate radiation by different amounts as a function of time because of variable emission rates.
 - (3) Produce deposits on the optics which, when solar radiated, produce spectrally selective filtering action.

d. EMI from various powerlines, equipment, and interaction of electrostatic charges on the Orbiter surfaces.

The condensible contributions of various effects are shown in figure C.2-1.

These depositions will affect the quality of sensor performance in two ways. First, by light absorption and second, by a loss of resolution due to light scattering by the deposited contaminants. At a maximum, the potential degradation could reach the levels shown in table C.2-4.

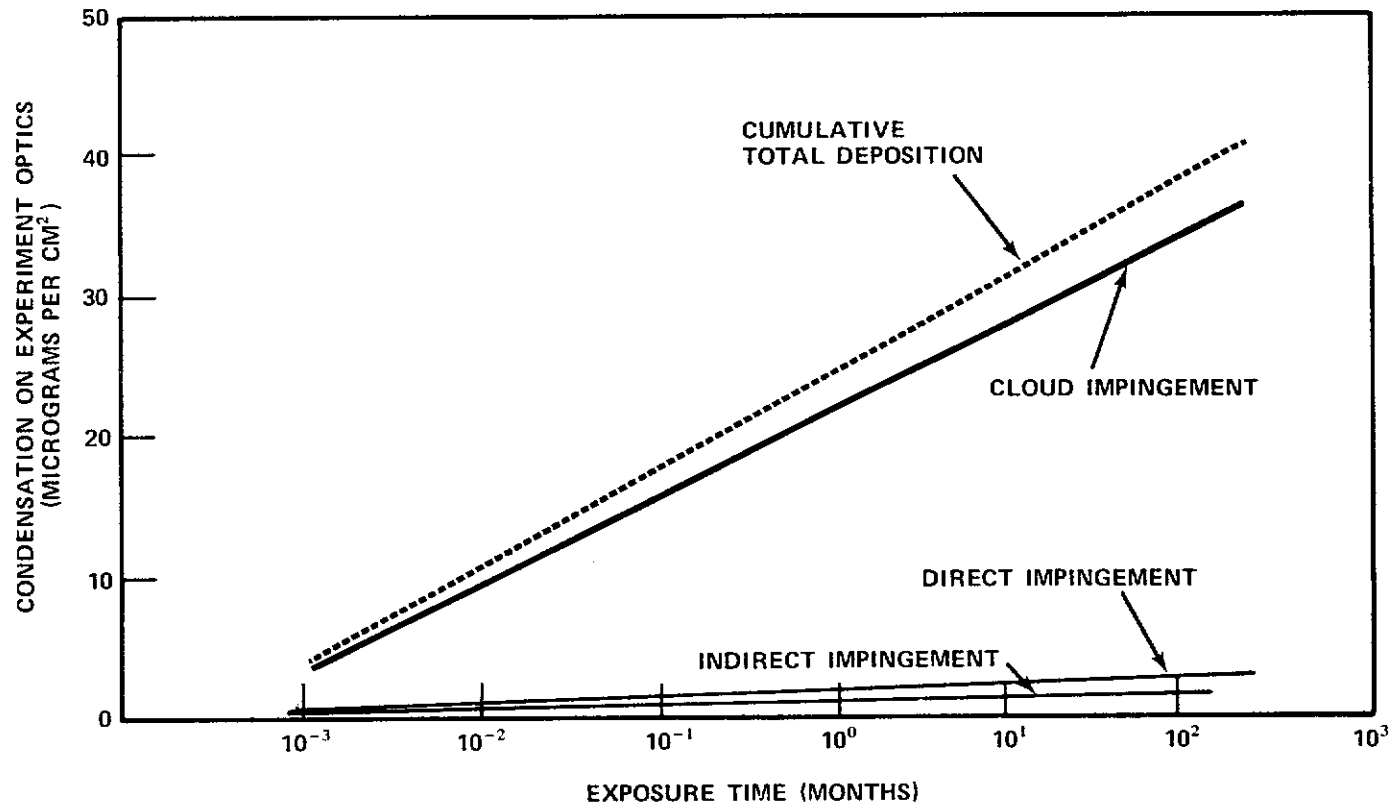

Figure C.2-1. - Condensible deposition versus time.

TABLE C.2-4

POTENTIAL SENSOR PERFORMANCE DEGRADATION VERSUS SPECTRAL REGION

| Spectral Region | Wavelength (Å) | Absorption Due To Deposition (%) | Loss of Resolution Due To Deposition Scattering (%) |
|-----------------|----------------------------|----------------------------------|---|
| Far UV | 800 - 1600 | 3 | 15 |
| UV | 1600 - 4000 | 3 | 30 |
| Visible | 4000 - 7000 | 2 | 30 |
| Near IR | 7000 - 15000 | 5 | 20 |
| Far IR | 1.5 - 30 x 10 ³ | 5 | 15 |

The effect of condensibles on instrument radiative coolers is to significantly reduce their efficiency, thus increasing the operating temperature of the detectors and degrading their performance. The likelihood of this occurring is relatively low since instrument radiators are typically covered or shielded and are not at a significantly lower temperature than their surroundings until their exposure to cold space.

APPENDIX C.3

INTERFERENCE PROBLEMS FOR AMPS INSTRUMENTS

CONTENTS

| Section | Page |
|---|-------|
| 1.0 INTRODUCTION. | C.3-1 |
| 1.1 <u>GENERAL</u> | C.3-1 |
| 1.2 <u>EMI</u> | C.3-1 |
| 1.3 <u>DUST AND GAS</u> | C.3-2 |
| 2.0 TYPES OF INTERFERENCE, EMI AND OPTICAL. | C.3-3 |
| 3.0 INSTRUMENTS THAT ARE EMI SOURCES. | C.3-4 |
| 4.0 INSTRUMENTS SUSCEPTIBLE TO EMI. | C.3-5 |
| 5.0 INSTRUMENTS THAT ARE SOURCES OF DUST AND GAS. | C.3-7 |
| 6.0 INSTRUMENTS SUSCEPTIBLE TO DUST AND GAS | C.3-9 |

1.0 INTRODUCTION

1.1 GENERAL

The environment on the Orbiter will affect the performance of a number of instruments, some severely. The environmental problems are divided into two categories: (1) EMI, and (2) dust and gas.

1.2 EMI

The Orbiter will not be EMI clean. The EMI will be more severe than for any satellite flown to date or planned. Different parts of the vehicle will be charged to different voltages. Currents will flow between many different sections. Operation of most of the accelerator and rf transmission instruments will preclude simultaneous operation of many other instruments.

Work on analyzing the EMI will lead to more specific identification of what can and cannot be accomplished. However, it seems clear that plasma and low energy particle measurements cannot be made from the Orbiter. It is doubtful if believable charged particle measurements below 100 eV can be made.

In this section we have identified those instruments that will be sources, or susceptible to, EMI. The worst sources are the accelerators and rf transmitters. The most sensitive are the field and wave detectors.

A subsatellite could be made relatively clean electrostatically and with little EMI.

1.3 DUST AND GAS

Optical instruments are severely affected by a small amount of dust in the FOV. These may cause thermal emission in the IR

Mechanical movements on the Orbiter will raise dust. A particular dust particle may require a complete orbit to drift out of the FOV or to become of no more interest. Solenoids to change filters, scanning mechanisms, boom deployment, pallet movement, etc., will contribute to the dust. Some data processing techniques may eliminate the effects of dust in the near field.

Gases may freeze out on cryogenically cooled surfaces and dust may contaminate optical windows by sticking to their surface. Some consideration must be given to frosting. It may coat mirrors, etc.

Outgassing, gas releases, contaminants from alkali metal releases, and rocket motors can lead to a number of degradations. The scattering of radiation from various gases can lower sensitivities. These contaminants will affect mass spectrometer observations.

2.0 TYPES OF INTERFERENCE, EMI AND OPTICAL

The major types of interference are listed below.

- a. Orbiter generated:
 - (1) Dc and ULF ac fields caused by power systems.
 - (2) Rf fields generated by telemetry and command and control functions.
 - (3) E fields caused by vehicles asymmetric charging.
 - (4) Gas and dust caused by thrusters, outgassing, and mechanical motions.
- b. Rf fields (continuous and pulsed) generated by experiments.
- c. Dc/ULF H and E fields generated by experiments.
- d. Gasses and dust generated by experiments.
- e. Extraneous optical signals generated by experiments, i.e., release of gaseous species or plasmas.
- f. Contamination of neutral species experiments.

3.0 INSTRUMENTS THAT ARE EMI SOURCES

The following are candidates for EMI sources.

- a. Orbiter vehicle, dc switching, telemetry and communications.
- b. 301 Ion Accelerator.
 - (1) ~ DC current systems \rightarrow ΔH , dc and ac.
 - (2) Vehicle charging \rightarrow ΔE , dc and ac.
- c. *303 Electron Accelerator (similar sources as above).
- d. *304 MHD Arc.
- e. 306 High Voltage Plasma Gun.
- f. 405 Radio Frequency Sounder - high power rf signals and pulsed HV and vehicle charge variations.
- g. 406 Incoherent Scatter Radar Measurements.
- h. 407 ULF Antenna and ULT Transmitter.
- i. 408 Tethered Satellite, for ULF Magnetospheric Measurements.
- j. 409 Doppler-Tracking Bistatic Sounder of STS/AMPS Wake.
- k. 410 Coherent Scatter Radar Measurements.
- l. 415 VLF Quadrupole Probe.
- m. 417 Resonance Cone Techniques.
- n. 418 VLF Antennas and Transmitter.
- o. 546 Plasma Accelerator, (SEPAC).

*ASF instruments.

4.0 INSTRUMENTS SUSCEPTIBLE TO EMI

The following are susceptible to EMI problems.

- a. 405 Radio Frequency Sounder - vehicle rf emissions, i.e., telemetry and communications (also 301, 303, 304 and 306).
- b. 406 Incoherent Scatter Radar Measurements.
- c. 407 ULF Antenna and ULT Transmitter - vehicle rf + 406, and 301.
- d. 408 Tethered Satellite for ULF Magnetospheric Measurements - (depends upon distance from Orbiter).
- e. 409 Doppler Tracking Bistatic Sounder of STS/AMPS Wake.
- f. 410 Coherent Scatter Radar Measureme. ts.
- g. 411 ELF/VLF Receiver.
- h. 415 VLF Quadrupole Probe.
- i. 416 VLF Wave Fields.
- j. 417 Resonance Cone Techniques.
- k. 526 Photoelectron Secondary Electron Spectrometer.
- l. 527 Langmuir Probe.
- m. 530 HF Quadrupole Probe.
- n. 535 Direct Current Electric Field.
- o. *536 Triaxial Fluxgate.
- p. 537 Ion Mass and Distribution Analyzer.
- q. 538 Subsatellite Ion Mass And Distribution Analyzer (see 537).
- r. 540 Medium Energy Ion Mass Analyzer (see 537).
- s. 542P Medium Energy Ion Mass Detector.

*ASF instruments.

- t. 544 Medium Energy Electron Detector.
- u. 547 Ion Drift Detector.
- v. 548 Vector Magnetometers.
- w. *550 Faraday Cup, etc.
- x. 551 Level III Diagnostic Group.
- y. 552 Low Energy Electron Beam Experiments.

*ASF instruments.

5.0 INSTRUMENTS THAT ARE SOURCES OF DUST AND GAS

The following are sources of dust and gas.

- a. Orbiter - outgassing, dust, window contamination, attitude control jets.
- b. *116 Airglow Spectrograph - translation of collimator mirror - dust.
- c. 120 Meteor Gun - dust generator.
- d. *122 UV-VIS-NIR Spectrometer - translation of telescope - dust.
- e. 123 Far UV TV system - changing corrector plates, filters - dust.
- f. 213 Laser Sounder - extraneous optical signals.
- g. 301 Ion Accelerator - extraneous species and optical radiations.
- h. *303 Electron Accelerator.
- i. *304 MPD Arc.
- j. 306 HV Plasma Gun.
- k. 406 Incoherent Scatter Radar - dust generator from antenna motions.
- l. 407 ULV Antenna.
- m. 408 Tethered Satellite - dust and gas generation at launch.
- n. 410 Coherent Scatter Radar (see 406).
- o. Boom motions - dust generation (411, 415, 416, 417, 530, 535).
- p. 533 Throwaway Plasma Accelerator (TAPAC) - extraneous optical signals.

*ASF instruments.

- q. *534 Optical Band Imager And Photometer System (OBIPS) - many external moving parts as sun shutter - dust.
- r. 546 Plasma Accelerator (SEPAC) - extraneous species and optical radiations.
- s. *549 Gas Plume Release - extraneous species.
- t. 552 Low Energy Electron Beam Experiments (LEEBEX) - (check various subsystems).
- u. *1002 Pyrheliometer and Spectrophotometer - door open and close - dust.

*ASF instruments.

6.0 INSTRUMENTS SUSCEPTIBLE TO DUST AND GAS

The following instruments are susceptible to dust and gas.

- a. *116 Airglow Spectrograph.
- b. *118 Limb scan IR Radiometer.
- c. 121 Neutral Mass Spectrograph - vehicle outgassing and propellants 120 meteor gun contamination.
- d. *122 UV-VIS-NIR Spectrometer.
- e. 123 Far UV TV system.
- f. *124 Fabry-Perot Interferometer.
- g. 125 Neutral Temperature and Wind Spectrometer.
- h. *126 IR Interferometer.
- i. *213 Laser Sounder.
- j. *534 Optical Band Imaging And Photometer (OBIPS).
- k. *1002 Pyrheliometer and Spectrophotometer.

*ASF instruments.

APPENDIX C.4

SPACE SHUTTLE PROGRAM OFFICE CORRESPONDENCE



NATIONAL AERONAUTICS AND SPACE ADMINISTRATION
LYNDON B. JOHNSON SPACE CENTER
HOUSTON, TEXAS 77058



REPLY TO
ATTN OF:

WA2-117

June 12, 1975

TO: George C. Marshall Space Flight Center
Attn: PD01/Director, Preliminary Design Office

FROM: LA3/Deputy Manager, Management Integration Office

SUBJECT: AMPS EMI Requirements

Reference is made to your letter PD01(75-38), same subject, dated April 16, 1975.

The present Orbiter design and EMC Control Program will not control the electromagnetic environment to the levels required for operation of AMPS experiments sensitive to electromagnetic fields. However, the present Orbiter design and EMC Control Program are adequate to permit non-interfering operation between Orbiter and payload electronic equipment that are not specifically designed to sense or measure electromagnetic fields.

Figure I through Figure VI (Enclosure 1) represent predictions of the magnetic flux density at 10 and 25 meters off the Orbiter X axis. The predictions are based on specification values for allowable conducted emissions contained in MIL-STD-461A. The prediction data is qualified as follows:

a. No predictions are made for frequencies below 30 Hz, since specification values are not available below this frequency. It is suspected that semiconductor noise ($1/f$) may start to dominate at the lower frequencies with a resulting increase in magnetic flux density.

b. Both broad band and narrow band predictions are made; however, it should be noted that narrow band emissions dominate in the frequency region of interest. Therefore, selection of a center frequency and bandwidth for a sensitive experiment should avoid high narrowband emission areas of the spectrum. These areas can be determined by test.

c. Predictions are based on geometric factors associated with the power distribution systems and on orbit load profiles. For further information on the analysis, contact Jack Zill, area code 713, 483-3361.

Comparing the predictions with AMPS requirements indicates an approximate 3 order-of-magnitude difference between the predictions and the AMPS requirements. A design improvement in the Orbiter, consisting of changing the power distribution system from a structure return concept to a single point ground-twisted pair concept, should reduce the field levels by approximately 3 order-of-magnitude. This improvement would require the addition of 750 to 800 pounds of wiring to the Orbiter with unknown cost and schedule impacts. A proposed change to incorporate a single point ground-twisted pair power distribution system was rejected by the Shuttle Program Manager last year.

Other improvements suggested in the enclosure to your letter have been considered but have been rejected for either cost, weight, or technical reasons. In general, the suggested improvements yield insignificant reductions in field levels and have significant schedule, cost, and weight impacts.

Two options are suggested to further investigate solutions for sensitive experiment requirements:

a. If MSFC desires and is willing to fund the additional effort, JSC will attempt to obtain an ECP from Rockwell/SC for a kit to provide a single point ground-twisted pair power distribution system.

b. Experiments requiring an extremely quiet electromagnetic environment could be deployed on long booms, tethered or as free flyers.

Shuttle resources are limited; however, we are willing to pursue additional solutions if the payload community desires to fund such effort.

R. M. Machell

cc:
NASA Hqs., MHE/R. V. Murad
MSFC, EL55/R. Evans
PS01/R. Ise
SA01/R. E. Lindstrom

Enclosure

bcc:
EJ5/C. F. Herman
LP/J. C. Heberlig
WA2/J. A. Zill
WA2/J. D. Lobb

WA2/RLBlount:vk:6/10/75:3361

C.4-2

COPY OF ORIGINAL

MAGNETIC FIELD SPECTRAL DISTRIBUTION
NARROW BAND - LOW FREQUENCY

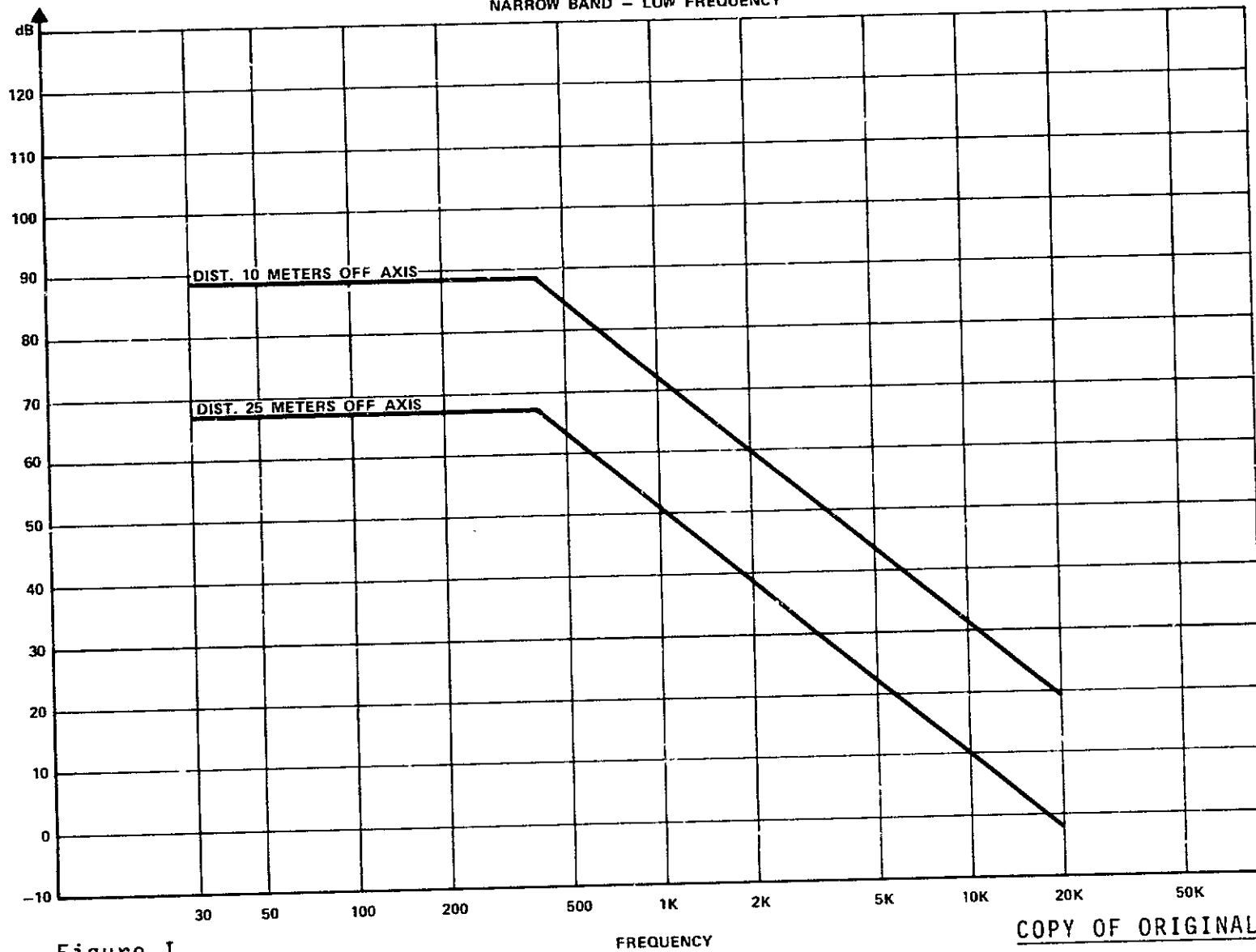

C.4-3

Figure I

COPY OF ORIGINAL

MAGNETIC FIELD SPECTRAL DISTRIBUTION
NARROW BAND - HIGH FREQUENCY

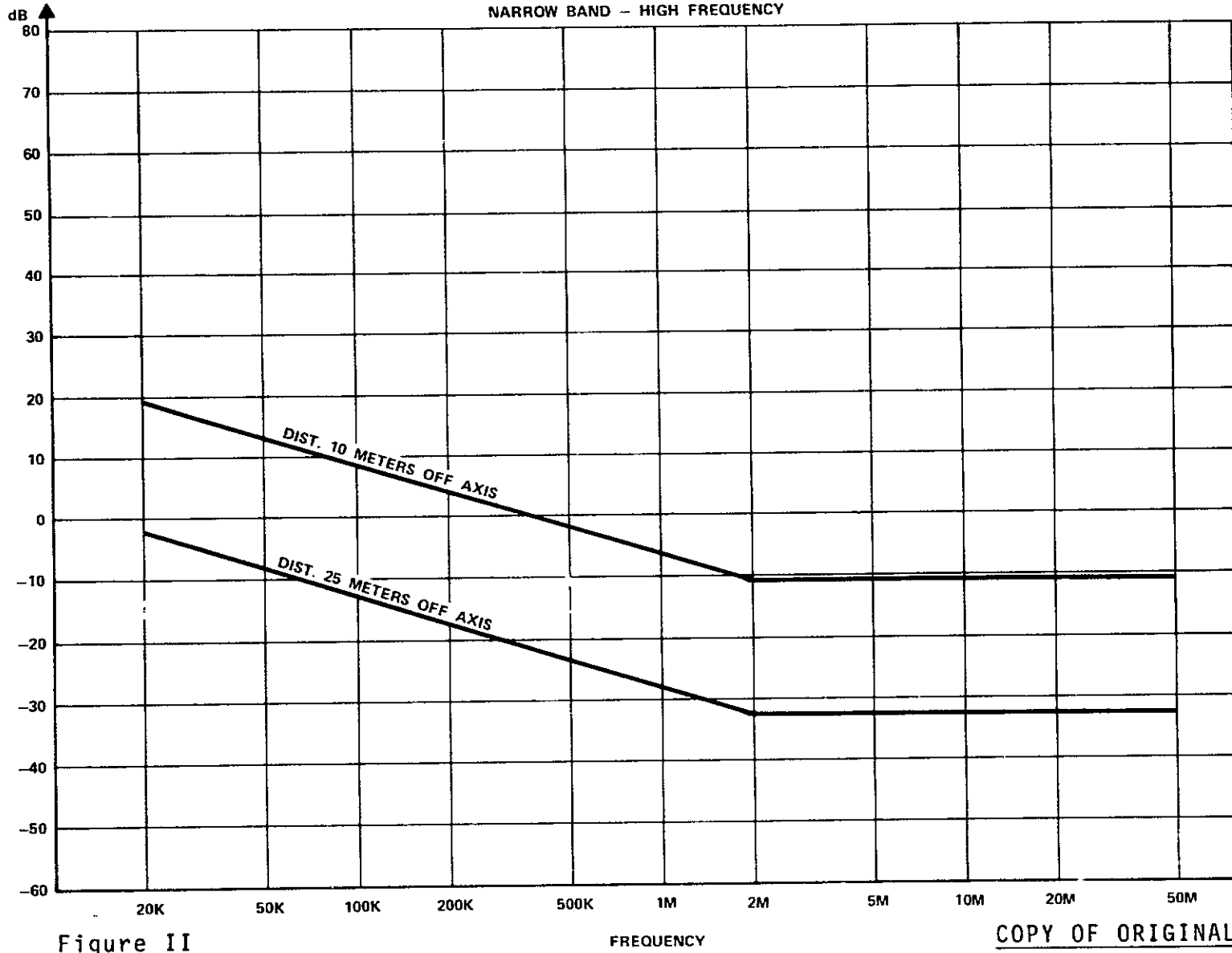

C.4-4

Figure II

COPY OF ORIGINAL

MAGNETIC FIELD SPECTRAL DISTRIBUTION
BROAD BAND - LOW FREQUENCY

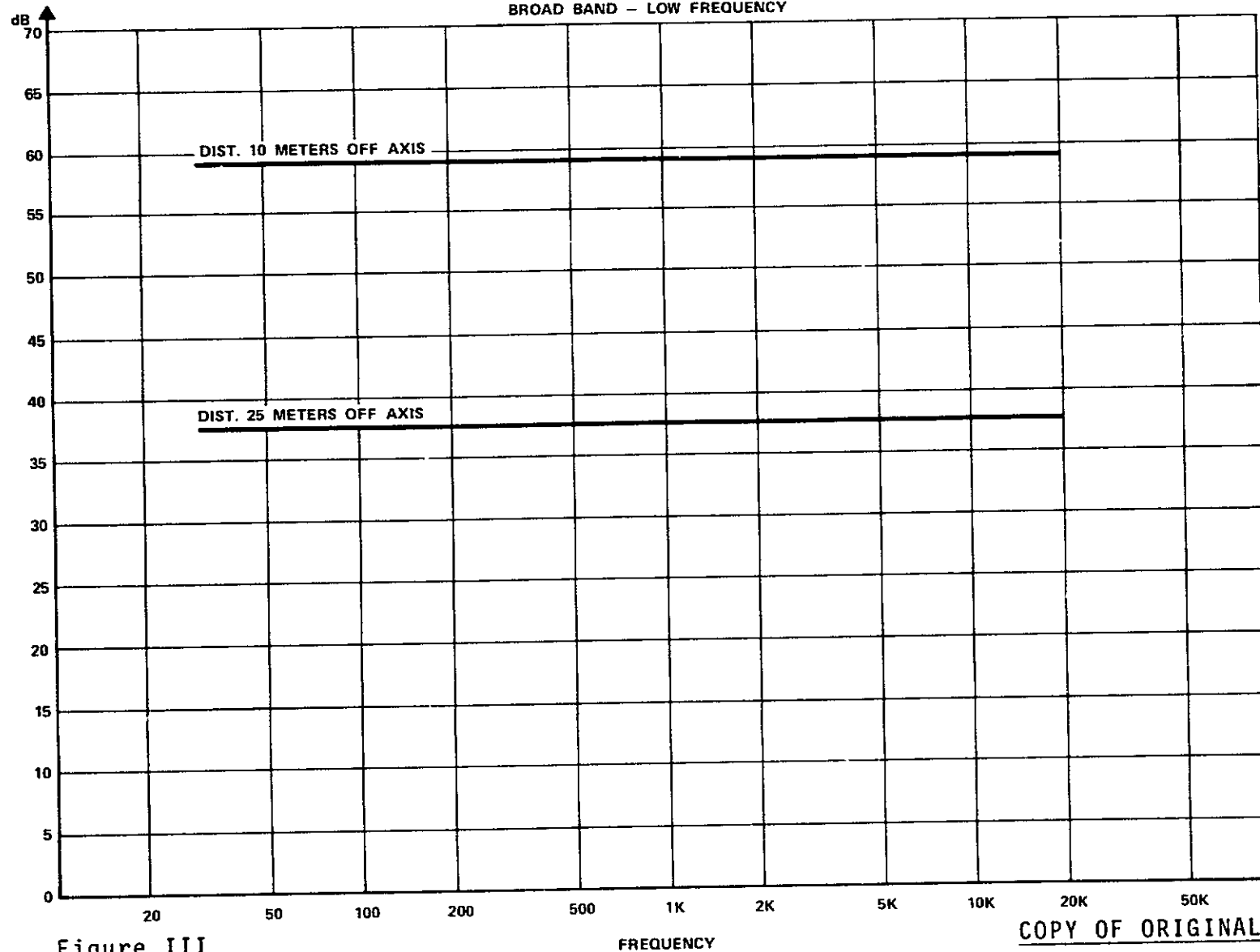

C.4-5

Figure III

COPY OF ORIGINAL

MAGNETIC FIELD SPECTRAL DISTRIBUTION
BROAD BAND - LOW FREQUENCY

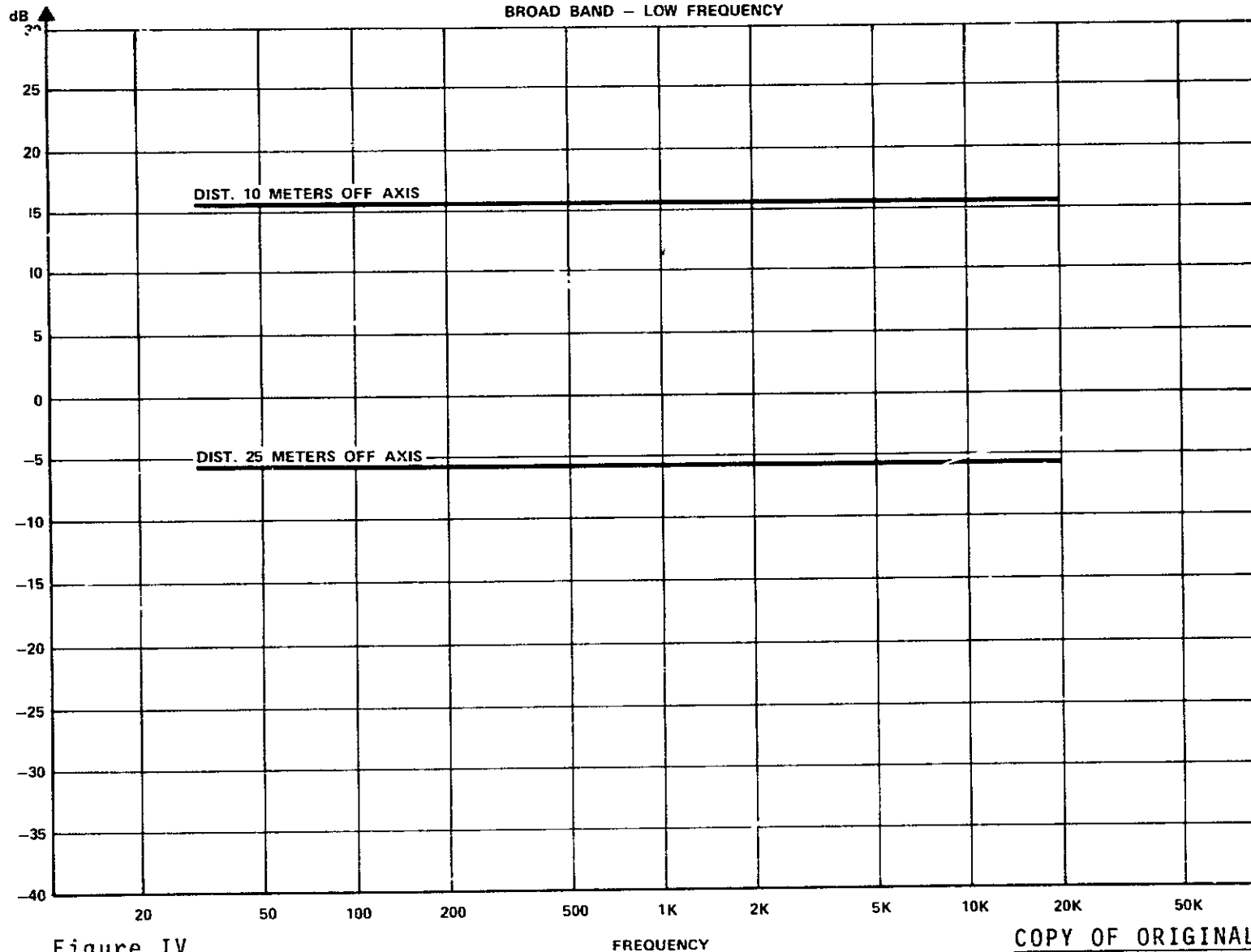
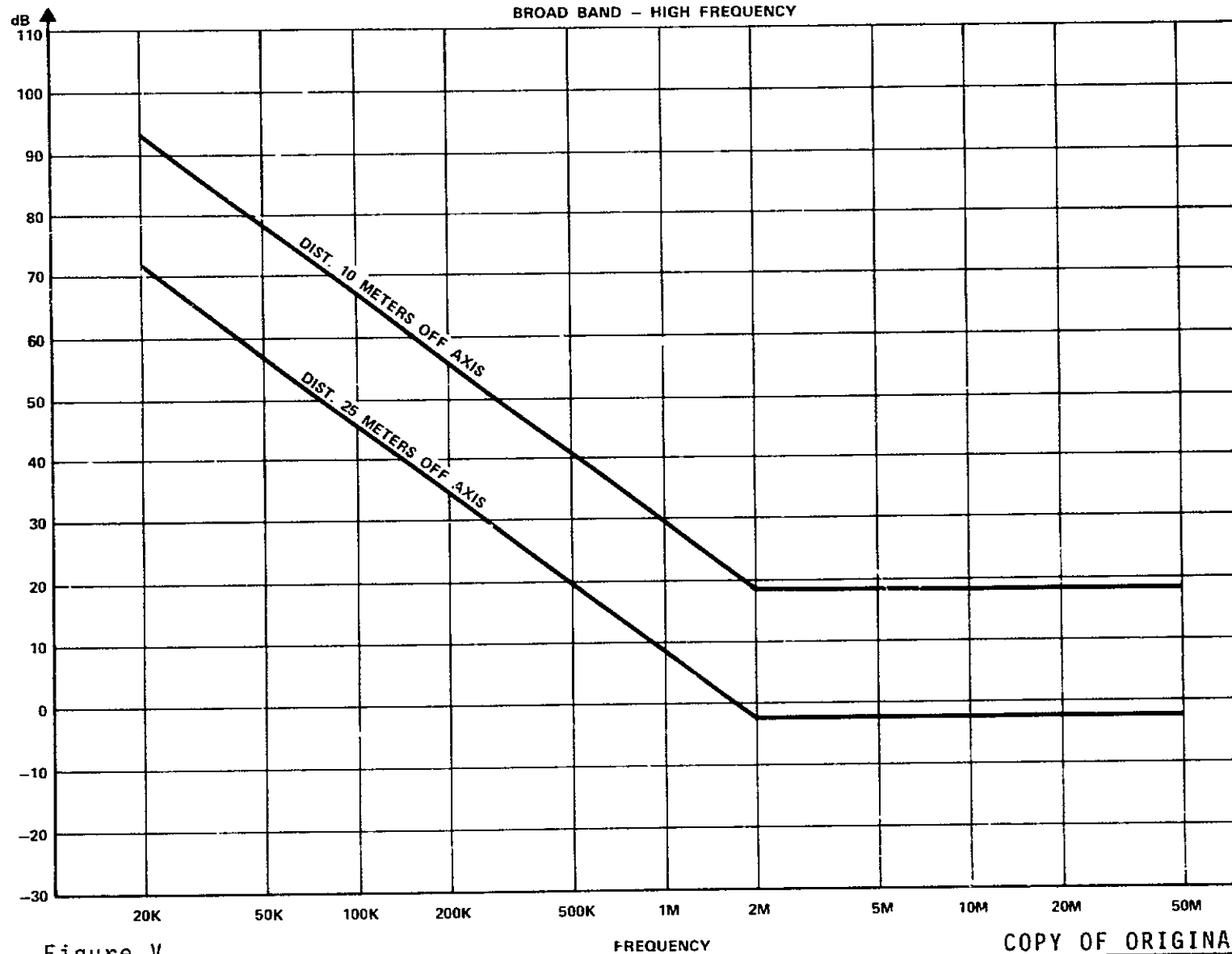

Figure IV

COPY OF ORIGINAL

C.4-6

MAGNETIC FIELD SPECTRAL DISTRIBUTION
BROAD BAND - HIGH FREQUENCY



C.4-7

Figure V

COPY OF ORIGINAL

C.4-8

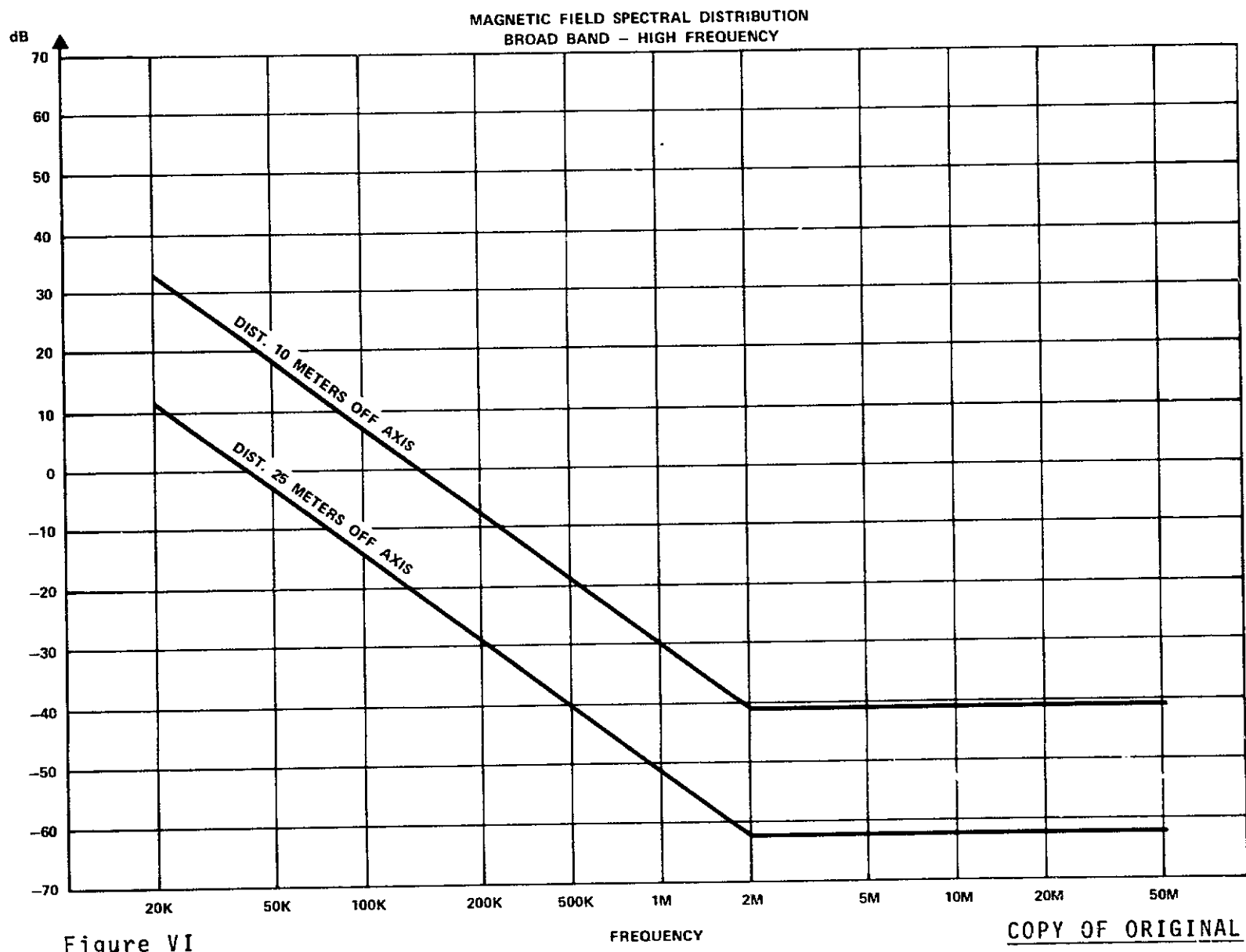

Figure VI

APPENDIX D
CENTRALIZING AND STANDARDIZING
INSTRUMENT SUBSYSTEMS
FOR THE
ATMOSPHERIC, MAGNETOSPHERIC AND PLASMA-IN-SPACE
(AMPS)

CONTENTS

| Section | Page |
|--|------|
| 1.0 INTRODUCTION | D-1 |
| 1.1 <u>BACKGROUND</u> | D-1 |
| 1.2 <u>SCOPE</u> | D-2 |
| 2.0 INSTRUMENT SYSTEM DESIGN | D-4 |
| 2.1 <u>TYPICAL INSTRUMENT SYSTEM</u> | D-4 |
| 2.2 <u>SENSOR SUBSYSTEM</u> | D-4 |
| 2.3 <u>SCIENTIFIC DATA PROCESSING SUBSYSTEM</u> | D-8 |
| 2.4 <u>ENGINEERING DATA PROCESSING SUBSYSTEM</u> | D-10 |
| 2.5 <u>COMMAND AND CONTROL SUBSYSTEM</u> | D-10 |
| 2.6 <u>POWER CONDITIONING SUBSYSTEM</u> | D-11 |
| 3.0 MODULARIZATION, STANDARDIZATION AND CENTRALIZATION | D-13 |
| 3.1 <u>MODULARIZATION</u> | D-13 |
| 3.2 <u>STANDARDIZATION</u> | D-13 |
| 3.3 <u>CENTRALIZATION OF INSTRUMENT ELECTRONICS</u> | D-15 |
| 3.3.1 ADVANTAGES | D-15 |
| 3.3.2 DISADVANTAGES. | D-16 |
| 3.4 <u>SUMMARY OF STANDARD MODULE PACKAGING REQUIREMENTS</u> | D-16 |
| 3.5 <u>EXISTING PACKAGING METHODS USING STANDARD MODULES</u> | D-17 |
| 3.5.1 NIM-CAMAC MODULES. | D-17 |
| 3.5.2 NAVY QUICK AND EASH DESIGN (QED) MODULES | D-18 |
| 3.5.3 NAVY STANDARD HARDWARE PROGRAM (SHP) MODULES | D-18 |
| 3.5.4 ATR CASES. | D-18 |
| 3.5.5 DEFICIENCIES | D-19 |

| Section | Page |
|--|------|
| 3.6 <u>APPLICABILITY TO AMPS/ASF PAYLOADS.</u> | D-20 |
| 3.6.1 POWER CONDITIONING | D-21 |
| 3.6.2 SCIENCE AND HOUSEKEEPING DATA. | D-21 |
| 3.6.3 COMMAND AND CONTROL. | D-21 |
| 3.6.4 MECHANICAL AND OPTICAL SUBSYSTEMS. | D-21 |
| 4.0 STUDY SUMMARY. | D-23 |
| 5.0 CONCLUSIONS AND RECOMMENDATIONS. | D-24 |
| 6.0 APPLICABLE REFERENCES. | D-25 |

FIGURES

| Figure | Page |
|--|------|
| D.2-1 Functional block diagram of a typical instrument system. | D-5 |
| D.2-2 Functional block diagram of proposed instrument support system | D-6 |
| D.2-3 Sensor subsystem output forms. | D-9 |

TABLES

| Table | Page |
|--|------|
| D.2-1 AMPS SENSOR SUBSYSTEM TYPES. | D-7 |

1.0 INTRODUCTION

This appendix treats potential advantages that might be realized through a concept of standardizing, modularizing, and centralizing instrument electronics. This conceptual consideration encompasses not only potential cost savings realizable in the design, manufacturing, and test areas, but also potential advantages in the areas of replaceability, maintainability, system expansion, and preflight checkout. This concept will be applied to the ASF and AMPS payloads during later phases of this study, and will be a pertinent subject during the follow-on study task described in section 9.0 of this report.

1.1 BACKGROUND

Historically, the constraints of minimized weight, available power and volume have been imposed upon scientific experiment instrumentation flown on spacecraft. These constraints, applied to highly developed equipment, have resulted in the custom design and packaging of experiment hardware. Treating each experiment package as an individual and unique instrument has led to recurring design and development efforts. This duplication of engineering, coupled with the requirement for high reliability, have contributed significantly to the current high cost of experiment instrumentation. The costs associated with a typical instrument development program are estimated below:

| | |
|-----------------------------------|-----|
| Engineering | 35% |
| Manufacturing and Testing | 40% |
| Reliability and Quality Assurance | 15% |
| Program Management | 10% |

Engineering, manufacturing and testing representing the largest portion of program expense are obvious candidates for cost reduction. An effective method for achieving cost savings in these areas will be the utilization of standardized equipment.

The effects of standardization on experiment hardware costs will include:

- a. Reduction of recurring design and development costs.
- b. Reduction of manufacturing costs due to the efficiencies of larger scale production.
- c. Reduction of development and qualification testing costs.
- d. Reduction of reliability and quality assurance costs due to reliability growth associated with large scale production.

Due mostly to the constraints mentioned earlier, spacecraft experiment hardware, to date, has not been significantly standardized. The availability of the Orbiter will make considerable standardization feasible, if an appropriate experiment system design approach is adopted.

Whether the use of standardized equipment will be a viable option depends critically upon the extent to which the instrument systems can be divided into functional elements that have common applications. Identification of common functional elements leads to design standardization and modularization. The use of standard modules invariably results in non-optimization of instrument size, weight, and power requirements. The larger payload capability (weight and volume) and the relatively greater amounts of spacecraft power provided by the Orbiter makes the use of standard modules feasible.

1.2 SCOPE

Conducting a spaceflight experiment may be divided into the following phases:

- a. Experiment definition.
- b. Instrument development.
- c. Instrument integration with the spacecraft.
- d. Experiment operations.
- e. Data reduction and analysis.

Each phase contributes to the total program cost, and no doubt, contains areas where cost savings might be realized. However, this study is limited to the area of instrument development. Further, it concentrates on the instrument electronics because this seems the most likely route to instrument cost reduction. The instrument system design will be examined to determine the extent that it can be partitioned into common functional elements. Definition of these elements will allow the general specification of standard modules. Finally, the technique of centralizing the standard modules will be applied to the ASF portion of the Orbiter AMP's payload.

2.0 INSTRUMENT SYSTEM DESIGN

2.1 TYPICAL INSTRUMENT SYSTEM

This study has shown that almost all scientific instruments consist of a sensor subsystem and various support subsystems. The sensor subsystem contains the sensors, and in some cases specialized signal conditioning, and data compression electronics to satisfy the scientific objectives of the particular type of instrument. Figure D.2-1 illustrates a functional block diagram of a typical instrument system. The electronics or sensor support subsystem, generally required, performs basically four discrete functions. These functions are that of power conditioning, processing the command and control functions, science data processing, and engineering data processing. Of the four functions, the science data processing subsystem has the widest variety of sensor-to-subsystem requirements imposed on it. Therefore, this subsystem accounts for a large portion of the instrument system, but has received relatively little previous attention toward standardization. It is the intent of this study to show that by standardizing, modularizing, and centralizing the instrument electronics, considerable savings in design, part procurement, manufacturing, qualification testing, acceptance testing, and preflight checkout will be realized. This concept also offers a number of other advantages such as replaceability, maintainability, system expansion, system environmental control, electromagnetic interference (EMI) noise suppression, simplified preflight checkout of electronics, and an overall savings of payload weight and volume. Figure D.2-2 depicts how this concept fits the proposed AMPS/Orbiter system.

2.2 SENSOR SUBSYSTEM

A review of the potential instrument requirements for future Orbiter considerations has revealed that these instruments would cover six discrete disciplines: astronomy, high energy astrophysics, solar physics, atmospheric and space physics, earth observations, and earth and ocean physics. In order to satisfy these six disciplines, less than a dozen different type sensor subsystems will be required. Table D.2-1 presents a listing of

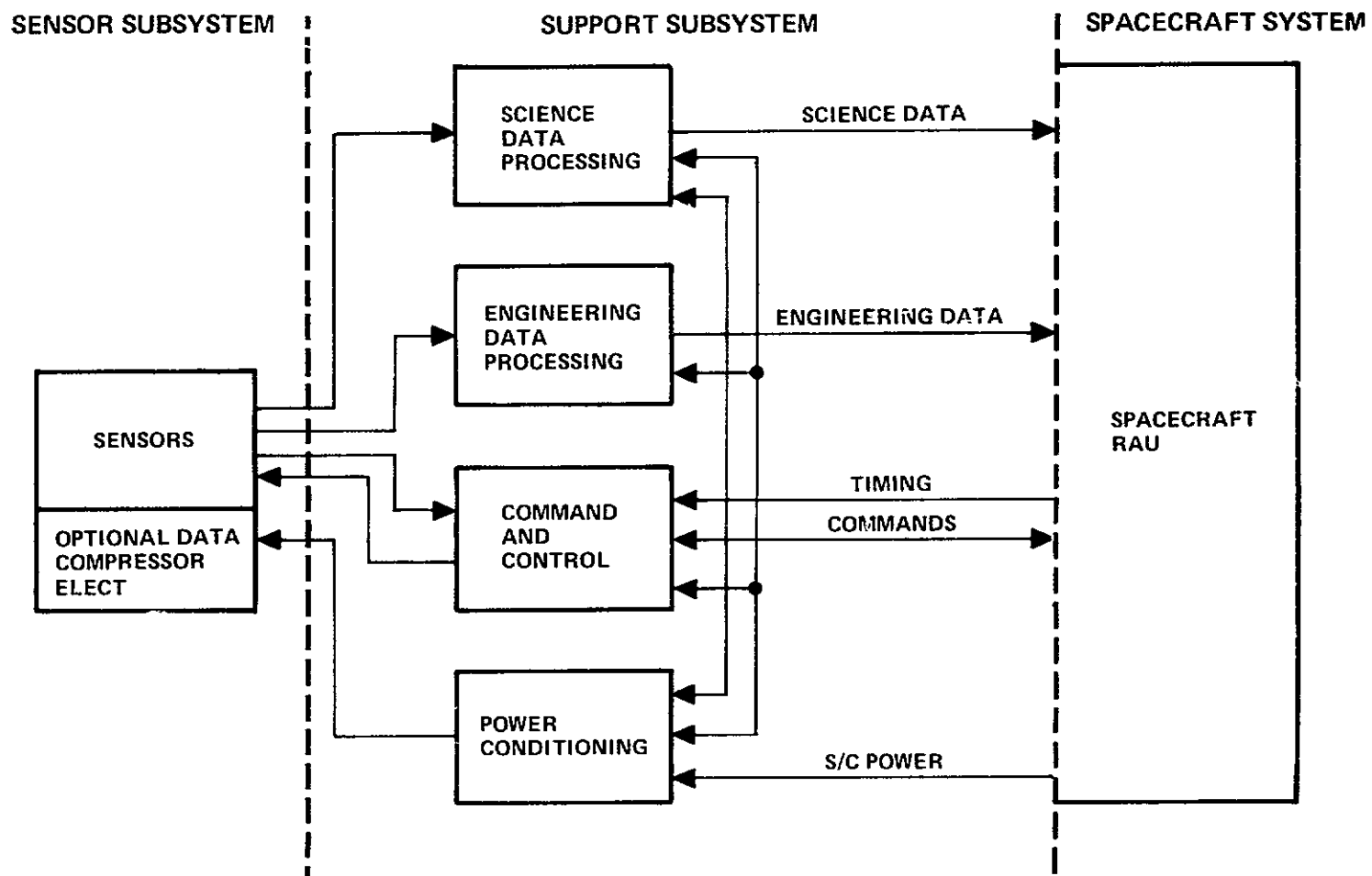

Figure D.2-1. - Functional block diagram of a typical instrument system.

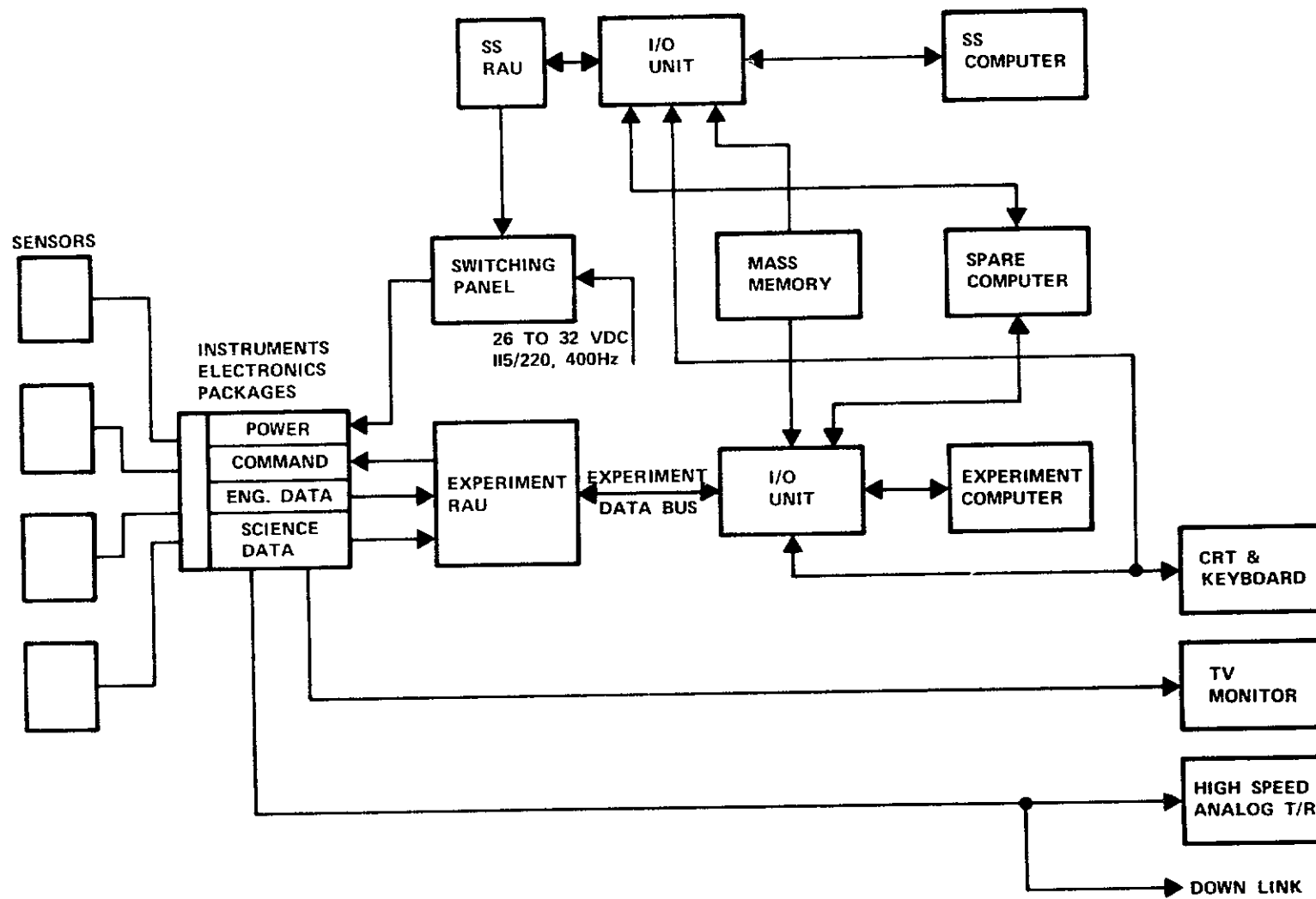

Figure D.2-2. — Functional block diagram of proposed instrument support system.

TABLE D.2-1. — AMPS SENSOR SUBSYSTEM TYPES

- Electron Multiplier
 - Photomultiplier Tube
 - Channel Multiplier
 - Single Anode Microchannel Plate
- Solid-State
 - Silicon Radiation Detector
 - Germanium Radiation Detector
- Micro Channel Plate Spatial
 - Multiple Discrete Anode
 - Self-Scan IC Anode Array
 - Resistive Anode
- Large Area Spatial
 - Spark Chamber
 - Multi-Wire Proportional Chamber
 - Drift Chamber
- Target-Electron Beam Spatial
 - Vidicon
 - SEC Vidicon
 - EBS Vidicon
 - Return Beam Vidicon
- IR
 - Photoconductive
 - Bolometric
- Magnetometer
 - Fluxgate
 - Rubidium Vapor
- Accelerometer
 - Electrostatic Proof Mass
- RF Receiver
 - VLF Spectrum Analyzer
 - HF Spectrum Analyzer
- Current Collector
 - Mass Spectrometer Readout
 - Langmuir Probe
 - Retarding Potential Analyzer
 - Ion Pressure Gauge

applicable sensor subsystems required to support proposed AMPS instruments. Of this grouping of sensor subsystems, the sensor output forms fall into four discrete categories:

- a. Digital pulse. This approach is a standardized logic pulse with a known temporal relationship to the occurrence of a specific sensor event.
- b. Analog pulse. This approach has a peak voltage proportional to the magnitude of the parameter being measured by the sensor during the event.
- c. Voltage level. This approach is the voltage level proportional to the magnitude of the parameter measured by the sensor.
- d. Voltage ramp. This approach gives the rate of voltage change proportional to the magnitude of the parameter being measured by the sensor (dv/dt).

Figure D.2-3 illustrates the sensor subsystem output forms. There may be some unique sensors that require special signal compression requirements to be built into the sensor housing itself. However, this study has shown that the majority of AMPS and ASF systems are conducive to separating the sensors from the electronics.

2.3 SCIENTIFIC DATA PROCESSING SUBSYSTEM

The function of the science data processing subsystem will be to receive the raw scientific data signals from the sensor subsystem and process them into an appropriate form for transmission to the spacecraft remote acquisition units (RAU). Although the sensor output characteristics may vary slightly from one type sensor to another, the basic design of this circuitry will be the same. This study has shown that a large cost savings can be realized on AMPS and ASF payloads by avoiding redundant redesign of separate instrument electronics, especially in this particular area. This approach will require a means whereby the raw data signal can be adjusted on the front end, so as not to prohibit the use of standardized modules for a wide variety of support subsystems. To enhance the flexibility of this type system, the sensor signal conditioning electronics will be designed onto quick replaceable boards allowing adjustment for special instrument grouping on a particular pallet, and also maximizing the number of instruments supported by a single

- DIGITAL PULSE

SCALER
EVENT LOGIC
TIME ENCODER

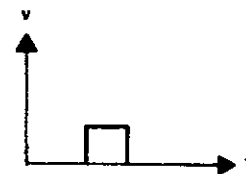

- ANALOG PULSE

PULSE AMPLITUDE

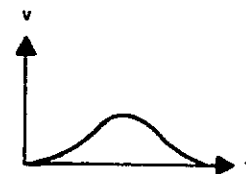

- VOLTAGE LEVEL

VOLTAGE LEVEL ADC

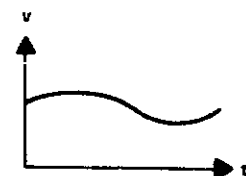

- VOLTAGE RAMP

DV/DT TO DIGITAL CONVERTER



Figure D.2-3. — Sensor subsystem output forms.

electronics subsystem. The standardizing and modularizing subsections of this report go further into the design concepts for the areas being proposed in this study.

2.4 ENGINEERING DATA PROCESSING SUBSYSTEM

The function of the engineering data processing subsystem will be to monitor the status of the various housekeeping parameters of the instrument. Basically, three types of engineering data will be considered: instrument status flags, sensor counting rates, and various analog information required to monitor instrument operation.

Instrument status flags are typically used to indicate the mode of operation of the instrument and is normally controlled through the command and control subsystem. Sensor counting rates are generally used to assess the instrument operating health status, provide inputs to voltage regulation circuitry, and provide information on sensor dead time so that appropriate corrections can be made to science data.

Analog information includes such parameters as power converter voltages, currents, and data from various transducers and thermistors. The proposed approach for handling analog information involves the use of voltage dividers within the instrument and interfaced to a RAU analog housekeeping channel, which is multiplexed by the RAU so that a single channel can be shared by several instruments. As with the other instrument support subsystems, the engineering data processing subsystem fits nicely into the standard module design concept.

2.5 COMMAND AND CONTROL SUBSYSTEM

The command and control subsystem functions are to accept commands and timing signals from the Orbiter RAU's, and to store, decode, and distribute these signals to the other three instrument subsystems. This subsystem controls the operating mode of the instrument, and it provides a means of power supply regulation for the other subsystems, as well as the sensor. Instrument clocks can be derived from the Orbiter clock through this subsystem. Also,

both simple and complex telemetry formats can be controlled through this subsystem, depending upon the instrument requirements.

This study has shown that very little commonality exists between the different subsystem functions, while the range of requirements for specific functions is reasonably narrow. Therefore, a good potential exists for standardizing this subsystem by specific function. However, for some unique instruments, a standardized command and control subsystem may not be feasible. In such cases, the unique functions would have to be performed within the sensor subsystem.

2.6 POWER CONDITIONING SUBSYSTEM

The power conditioning subsystem's function will be to generate the various supply voltages required to operate the instrument from the Orbiter experiment power distribution box. Basically, there will be three types of power conditioning required to support a typical AMPS or ASF instrument, which are for driving the analog electronics, the digital electronics, and the sensor subsystem.

This study has shown that for analog electronics, standardizing on ± 15 volts at one ampere or less allows maximum signal voltage excursion limits and the greatest flexibility. Also, both standard integrated circuit (IC) analog devices and analog electronics built with discrete parts can easily be made compatible with this voltage level.

Digital electronics can best be standardized into three discrete voltage levels. These are $\ll 1$ ampere at 10 volts, ≤ 1 ampere at +5 volts, and ≤ 1 ampere at -5.2 volts. Final selection of a power source for a particular instrument must of course consider trade-off of power consumption and heat dissipation versus the operation requirements. Also, if standard IC digital logic is used, each family has a different voltage requirement.

Sensor voltage requirements of course depend upon the type detector and its particular application. This study has shown that solid state detector

bias requirements generally are from 50 volts to 1 kV. Electron multiplexers usually require from 1 to 5 kV supplies. Large area spatial proportional chambers require from 3 to 6 kV. Target electron beam of the vidicon type sensors normally can be satisfied with a range of from 6 to 10 kV.

The power conditioning subsystem lends itself well to the concept of standardizing, modularizing, and centralizing the instrument electronics. There may be some restrictions of how far from the sensor the high voltage supplies can be located. Each application will require some special consideration, for example, special spacing and shielding will be a firm requirement in prevention of corona, especially in the pressure regions that the Orbiter will be flying. Also, for sensor protection during ground checkout and initial turn-on of the instrument electronics, sensor power supplies will be programmable by command.

3.0 MODULARIZATION, STANDARDIZATION AND CENTRALIZATION

3.1 MODULARIZATION

In order to adapt an instrument to modularization, the equipment must be broken into units which correspond to major functional elements. These units within the instrument system will be packaged in such a way that they can be easily removed, replaced, and reconfigured. To package the modules efficiently, a standard mounting rack or chassis will be provided.

The modules will be plug-in units with blind mating connectors, guides, and hold down hardware that allow rapid installation and removal. To insure that the modules will be readily maintainable and to facilitate troubleshooting, individual elements will have well-defined functional characteristics. Module design will provide easy access for servicing and will allow the use of automatic test sets.

The electrical and mechanical interfaces of the modular functional elements will be well defined to permit system modification and expansion by reconfiguring the system functions. Adequate interface definition will be required for procurement specifications and will insure module interchangeability between different vendors.

By the basic principles of the modular design approach, the internal instrument functions will be divided or partitioned into separate elements with closely specified interfaces and operating characteristics. This approach to system design imposes a certain degree of inflexibility which may not readily accommodate a new approach to component usage or allow incorporation of technological advances.

3.2 STANDARDIZATION

Standardization is the next logical step following modularization of the instrument system. Standardization refers to a design, manufacturing, and test system that will reduce the cost of instrument modules without becoming overly restrictive. In order to realize the full benefits of the standardized

module approach, commonality must be established between functional elements of as many instrument systems as possible. Standardization is mandatory if the Orbiter payloads are to be repaired and refurbished economically.

Numerous advantages result from the application of standardization to Orbiter instruments. Some of the obvious ones are listed below.

- a. The overall cost of the instrument design and development effort will be greatly reduced. Equally important, resources can be concentrated in the critical non-standard areas such as the sensor subsystem.
- b. The test program cost will be significantly lowered. Any particular standard module design will be qualification tested only one time. Acceptance testing will benefit from multiple usage of standardized test equipment, software, and procedures.
- c. Once the standard modules are designed and the first units fabricated, it will be possible to accurately predict the costs of subsequent units. This will allow the cost of proposed future experiment systems utilizing the standard modules to be more accurately estimated.
- d. Part procurement problems will be alleviated due to the ability to order in fairly large lots. The present custom-packaged instruments have invariably experienced long lead time purchase parts problems. To some extent, these delays have been due to the small, unprofitable quantities ordered from individual vendors.
- e. The reliability and quality assurance efforts will be appreciably streamlined. By having a relatively small family of standardized designs, such efforts as failure modes and effect analysis, non-metallic materials lists, electrical, electronic, and electromagnetic parts lists, and similar reports will be significantly reduced. By purchasing parts in large quantities, screening and burn-in of components would be facilitated. Multiple usage of fabrication and inspection quality control procedures will be possible.
- f. Logistic requirements will be eased due to the reduced number of spare components which will be required. This reduction will apply to both flight and backup modules and the engineering prototypes. Present

standardized modules have been the basis on which large pools of equipment have been assembled. Experimenters will draw from this pool to use in developing instrument engineering prototypes.

As with modularization, if the standardization specifications control the modules too rigidly, the incorporation of technological advances may be restricted. Also, if a module design is standardized, most certainly it will not be the optimum for each instrument in which it is used. This will lead to some sacrifice in weight, volume, and power efficiency. Hopefully, by the generation of a new family of standard modules specifically tailored to the requirements of space flight, these sacrifices may be minimized.

3.3 CENTRALIZATION OF INSTRUMENT ELECTRONICS

Centralizing the instrument electronics simply means that the sensor support subsystem will be removed from the sensor package and put into a centrally located package. This instrument electronics package (IEP) will house the electronics for from one to ten sensors, depending on the complexity of the sensors and the number of science and housekeeping data channels required.

3.3.1 ADVANTAGES

Definition of the requirements for this concept will not be an easy task; however, the advantages of this approach are certainly worth the effort. Some of the following advantages may have been covered previously in this report. If so, they are worth repeating.

- a. Cost savings realized from deleting redundant design by each instrument manufacturer.
- b. Cost savings by buying parts in large lots, screening parts and manufacturing modules in an assembly line fashion.
- c. Cost saving that can be realized from qualification testing of a reduced number of electronic packages.
- d. Cost savings from items a, b, and c for the instrument ground support equipment.

- e. This concept lends itself well to quick turn-around between Orbiter flights; in short, maintainability, replaceability, and system expansion.
- f. Centralizing the electronics simplifies the task of providing environmental control and EMI shielding.
- g. This concept can certainly simplify preflight checkout and inflight calibration.

3.3.2 DISADVANTAGES

In fairness, there are some disadvantages to centrally locating the instrument electronics.

- a. Both sensor and sensor electronics specifications become more difficult and require early finalizing.
- b. Principal Investigator (PI) enhancement of instruments becomes more complicated.
- c. Separating the sensor from the power source on the instruments that require high voltage can become a serious problem if not handled properly.
- d. Early verification of sensor-to-electronics interface checkout is required.

3.4 SUMMARY OF STANDARD MODULE PACKAGING REQUIREMENTS

In order to be suitable for use in the Orbiter experiment instrument systems, a standard module or family of modules should meet the following minimum requirements:

- a. Withstand launch environment.
- b. Conduction cooled.
- c. Blind mating, plug-in connectors.
- d. Simple captive mounting hardware.
- e. Readily maintainable.
- f. Facilitate system expansion and modification.

- g. Comply with non-metallic materials restrictions for flammability and outgassing.

3.5 EXISTING PACKAGING METHODS USING STANDARD MODULES

Four types of standard modules (NIM-CAMAC, Navy QED, Navy SHP, and ATR Cases) have been reviewed by previous studies (refs. 1 and 2) for applicability to spacecraft instruments. Summarized below are the salient features of each type of module.

3.5.1 NIM-CAMAC MODULES

- a. Convection cooled.
- b. Widely used by experimenters for ground based instrumentation.
- c. As presently designed, the module may not be suited for spacecraft environment.

Of the four existing module types reviewed, NIM-CAMAC seems to be the best candidate because of its functional partitioning. However, the modules would have to be modified and ruggedized to meet present Orbiter requirements.

In order to estimate the expected weight and power penalties that result from using NIM-CAMAC modules, a study was made of two Skylab earth resources instruments. A comparison of the weight and power for the required NIM-CAMAC electronics versus the as-built flight hardware for the S192 (13-band Orbital Multispectral Scanner) and S193 (Microwave Radar) showed the following:

| | <u>S-192 (Skylab)</u> | <u>S-192 (NIM-CAMAC)</u> | <u>Δ%</u> |
|--------|-----------------------|--------------------------|-----------|
| Weight | 441 lb | 821 lb | 186% |
| Power | 336 W | 670 W | 237% |
| | <u>S-193 (Skylab)</u> | <u>S-193 (NIM-CAMAC)</u> | <u>Δ%</u> |
| Weight | 370 lb | 660 lb | 178% |
| Power | 400 W | 660 W | 165% |

While it is inappropriate to generalize from this rather limited comparison, the average weight increase of 182 percent and power increase of 201 percent resulting from the incorporation of NIM-CAMAC modules gives an order of magnitude estimate of what might be expected.

3.5.2 NAVY QUICK AND EASY DESIGN (QED) MODULES

- a. Convection or conduction cooled.
- b. Presently in development by Naval Electronics Laboratory, San Diego.
- c. Catalog of high level functions not complete enough for experimenter's use.
- d. Due to its rugged design, the module is suitable for spacecraft use.

3.5.3 NAVY STANDARD HARDWARE PROGRAM (NSHP) MODULES

- a. Convection cooled.
- b. Presently used by the Navy in submarine and surface ship electronic equipment.
- c. Large catalog of low-level functions exists.
- d. Usage generates as much as a 6:1 and 4:1 increase in volume and weight respectively.

3.5.4 ATR CASES

- a. Widely used since 1940 for military and commercial avionics.
- b. Convection cooled (modification to conduction cooling is possible).
- c. Electronic functions must be designed and packaged by the experimenter.
- d. A new line of ruggedized modules required before suitable for use on spacecraft.

3.5.5 DEFICIENCIES

In addition to the weight and power problems associated with the NIM-CAMAC modules, the following deficiencies have been identified.

- a. The NIM-CAMAC power supplies will have to be redesigned to operate directly off the Orbiter electric bus voltage. This should result in reducing the required power by eliminating the power converters presently required.
- b. The non-metallic materials used in the NIM-CAMAC modules have not been controlled. The potential sources of outgassing represent a crew safety hazard when used in the crew compartment and an instrument contamination problem when used in the experiment bay.
- c. The NIM-CAMAC modules presently require forced air cooling. Both NIM and CAMAC compartments will require heat exchanger capability of approximately 150 W cooling for each NIM-bin and 450 W cooling per CAMAC compartment.
- d. Present CAMAC modules are manufactured with only one fixing screw at the bottom of the module front panel. A second fixing screw will be required.
- e. The mechanical interface between the CAMAC module and the rack has excessive clearance. The module runner and the mating guide will require redesign to prevent damage during vibration.
- f. The NIM-CAMAC standards imposed upon industry suppliers of the modules do not specify the use of threaded inserts for fastening aluminum. For flight applications, present NASA requirements for threaded or self-locking inserts should be imposed.
- g. The electrical connectors used in NIM and CAMAC equipment are prohibited by current NASA specifications for use in flight hardware.
- h. In order to prevent improper connections in the laboratory, NIM and CAMAC standards specify that identical connectors shall not be used on adjacent cables. This practice is contrary to the modular concept.
- i. The CAMAC modules use an edge-board connector which is prohibited for flight hardware. The edge-board connector design causes the connector

to be shorted out during insertion and withdrawal resulting in a burnout of board components if the board is powered.

- j. The CAMAC electrical grounding scheme combines power and signal ground. This practice is avoided in flight hardware to prevent ground loops.
- k. The Orbiter flight environments have not yet been fully established. If further study shows present predictions are too mild, the commercial NIM-CAMAC components may not be acceptable, and ruggedizing of the present designs could be an extensive effort.

Based upon available information, it appears that there is no suitable standardized modular electronics system presently available. The weight/power penalties and required modifications inherent with the best available systems, NIM-CAMAC, are not encouraging. The generation of a new family of standard modules specifically tailored to the requirements of space flight instruments seems to be the answer. A cost and performance trade-off study is recommended to determine the relative merits of modifying existing hardware and of producing a new standard module system.

3.6 APPLICABILITY TO AMPS/ASF PAYLOADS

The existing proposals for AMPS/ASF payload systems have incorporated a certain amount of standardization and centralization. As shown in figure D.2-2, the experiment and subsystem RAU's serve as the interface between the instrument system and the Orbiter. The RAU functions and interfaces have been well defined and serve as excellent examples of a standardized, modular unit. There are, however, additional functions within the instrument system which can be further standardized.

The functional subdivision of a typical instrument into support subsystems has been previously shown in figures D.2-1 and D.2-2. These instrument subsystems interface with the experiment and subsystem RAU's on one side, and the sensors on the other, and must provide means of communication between the two. Following are some of the potential areas of standardization for the AMPS/ASF instrument subsystems.

3.6.1 POWER CONDITIONING

The Orbiter power distribution system, as presently defined, provides 26 to 32 Vdc and 115, 220 V, 400 Hz. These must be converted into the voltages required by the individual instruments. There is a good deal of commonality of requirements within the ASF package as shown below:

| <u>No. of ASF Instruments</u> | <u>Power Requirements</u> |
|-------------------------------|--|
| 6 | High voltage — photomultiplier, electron multiplier type detectors |
| 4 | High voltage — capacitor bank |
| All | Low voltage regulated — analog housekeeping |

3.6.2 SCIENCE AND HOUSEKEEPING DATA

Six of the ASF instruments use photomultiplier, or electron multiplier type sensors. These sensors produce data in a similar format which must be conditioned to be acceptable to the RAU or high speed tape recorder. This data conditioning should provide an opportunity to incorporate standard, modular components. Additionally, the instrument housekeeping data will be of similar format and may require conditioning before going to the RAU.

3.6.3 COMMAND AND CONTROL

While each of the ASF instruments require some unique controls, there is a great deal of commonality which would lend itself to standardization and modularization. For example, each of the instruments must be turned off and on; in several cases different operational modes may be selected, or self calibrations performed.

3.6.4 MECHANICAL AND OPTICAL SUBSYSTEMS

In addition to the electrical subsystems previously defined, there are several mechanical and optical systems shared by the ASF instruments. While an identical design may not accommodate all the instruments in a particular category, there should be sufficient commonality to allow sharing of design,

fabrication, and testing techniques. These systems are outlined below to indicate other areas of standardization that should be explored.

| <u>No. of ASF Instruments</u> | <u>Subsystem Description</u> |
|-----------------------------------|--------------------------------|
| 5 | Optical telescopes |
| 3 | Cryogen systems |
| 6 | Moveable protective covers |
| 3 | Gas handling system |
| 11 | Pointing or scanning platforms |

4.0 STUDY SUMMARY

Using the current AMPS and ASF instrument proposals, a typical instrument system was defined. Using this typical system definition, a study was made to determine if it was feasible to remove from the individual instruments the sensor supporting electronics and combine them for several instruments into a single IEP. The study further considered the cost saving that might be realized by standardizing and modularizing the sensor support electronics within the IEP. It further considered the possibility of utilizing existing packaging methods such as NIM-CAMAC, Navy QED, Navy SHP, and ATR. This study made a special application of this centralizing, standardizing, and modularizing concept to ASF.

5.0 CONCLUSIONS AND RECOMMENDATIONS

5.1 CONCLUSIONS

Conclusions reached during this study are as follows:

- a. It is feasible to apply the centralized instrument electronics concept to payloads.
- b. Considerable cost savings can be realized in the areas of design, fabrication, and test.
- c. Standardizing and modularizing the IEP offer a number of advantages in the areas of replaceability, maintainability, system expansion and preflight checkout.
- d. Although the concepts are good, the use of existing standardized electronics such as NIM-CAMAC, Navy QED, ATR, and others are not acceptable for spaceflight type experiment hardware. This is largely because of the excessive weight and volume, and also the packaging technique is not suitable for spaceflight use.
- e. Establishing the technical requirements for designing the IEP will not be easy; however, the savings offered make it worth doing.

5.2 RECOMMENDATIONS

- a. Implementation of the centralized instrument electronics concept should be initiated on AMPS and ASF.
- b. Definition of the IEP specifications should be initiated as soon as sufficient instrument details are firmed up.

6.0 APPLICABLE REFERENCES

The following references were used in preparation of appendix D.

1. A Study of Low Cost Approaches to Scientific Experiment Implementation for Shuttle Launched and Services Automated Spacecraft, dated March 19, 1975, under NASA Contract NAS W-2717.
2. "Feasibility Study of Common Electronic Equipment for Shuttle Sortie Experiment Payloads," June 1975, Contract NAS 9-13784.
3. Spacelab Payload Accommodation Handbook, dated October 1974.

APPENDIX E

ASF PAYLOAD LOGISTICS AND TRANSPORTATION

CONTENTS
APPENDIX E

| Section | Page |
|---|------|
| 1.0 LOGISTICS | E-1 |
| 1.1 <u>INTRODUCTION</u> | E-1 |
| 1.2 <u>INSTRUMENT MANUFACTURING AND TEST AND CHECKOUT</u> | E-1 |
| 1.3 <u>INSTRUMENT CLUSTER INTEGRATION</u> | E-2 |
| 1.4 <u>PALLET MANUFACTURE AND TEST AND CHECKOUT</u> | E-2 |
| 1.5 <u>PALLET/INSTRUMENT CLUSTER INTEGRATION.</u> | E-2 |
| 1.6 <u>PALLET INTEGRATION (REMOTE SITE)</u> | E-3 |
| 1.7 <u>PAYLOAD PALLET INTEGRATION (LAUNCH SITE)</u> | E-4 |
| 1.8 <u>AMPS PAYLOAD FLIGHT INTEGRITY VERIFICATION</u> | E-7 |
| 2.0 TRANSPORTATION. | E-8 |
| 2.1 <u>ASSUMPTIONS.</u> | E-8 |
| 2.2 <u>INTRODUCTION</u> | E-8 |
| 2.3 <u>DESIGN CONSIDERATIONS AND RECOMMENDATIONS.</u> | E-8 |
| 2.4 <u>SHIPPING CONSIDERATIONS.</u> | E-9 |

LIST OF ILLUSTRATIONS

| Figure | Page |
|---|------|
| E-1 Payload installation and checkout facility. | E-5 |

1.0 LOGISTICS

1.1 INTRODUCTION

The fabrication and checkout flow requirements are the baseline to ASF hardware logistics and a determining factor influencing transportation modes and other requirements.

A review of the assembly and test and checkout flow requirements is necessary for an adequate understanding of the coordinated logistics and transportation plan. The major assembly and test and checkout flow requirements are presented below.

1.2 INSTRUMENT MANUFACTURING, TEST AND CHECKOUT

- a. For the manufacturer to make or buy instrument component parts the following functions are required.
 - (1) Test and prepare for assembly.
 - (2) Assemble.
 - (3) Test subassemblies as required.
 - (4) Test instrument with EGSE to ASF requirements. (This equipment should be provided by the manufacturer; however, ASF's unique equipment or interfaces will be entirely compatible with the next level of instrument integration to the extent that ASF's program will provide equipment for use at the manufacturer's plant(s), if necessary, to quantitatively establish mechanical and electrical interface compatibility and functional quality and reliability).
 - (5) Assemble instrument on handling fixture provided by ASF's program as MGSE.
 - (6) Package instrument/handling fixture and ship to instrument cluster integration facility.

1.3 INSTRUMENT CLUSTER INTEGRATION

The integration facility will receive and inspect the instruments, mount them on mobile lab dolly, and perform the following.

- a. Visual inspections.
- b. Mechanical interface (dimensional) verifications.
- c. Instrument functional tests (scientific and engineering parameters verification).
- d. Instrument integration will include:

- (1) The mechanical integration (cluster grouping interfaces verification).

NOTE: Each instrument handling frame may remain attached for the purpose of handling the cluster until it is ready for installation on the instrument cluster yoke.

- (2) Install instrument cluster (IC) into the IC yoke.
- (3) Perform interface continuity type test. This test may vary in extent from simple continuity to instrument turn-on and limited checkout such as measurement of basic housekeeping and engineering parameters.

1.4 PALLET MANUFACTURE AND TEST AND CHECKOUT

- a. Manufacture and fabricate pallet structural and wiring assembly to NASA approved ASF drawings to include the following.
 - (1) Check and adjust, as required, to gauge and/or dimensional requirements and perform wiring continuity tests.
 - (2) Package the pallet and ship to integration site.

1.5 PALLET/INSTRUMENT CLUSTER INTEGRATION

- a. The ASF integration facility will receive pallet assembly and perform the following functions.
 - (1) Perform receiving inspection. Verify mechanical and electrical interfaces to NASA approved documentation.

This should be major dimensional and electrical continuity requirements.

b. Pallet/RAU integration will include:

- (1) Install flight RAU's on pallet per ASF documentation.
- (2) Perform checkout of pallet/RAU installation through pallet interface.

c. Pallet/IC integration will include:

- (1) Install integrated IC/yoke assembly on the pallet yoke extender and connect electrical interfaces of IC and pallet.
- (2) Connect pallet to all facilities, i.e., electrical, cooling, hydraulic, etc., and prepare them for instrument and IC or experiment checkout.
- (3) After satisfactory checkout of the completed pallet, prepare the unit for system or multi-pallet integration tests.

1.6 PALLET INTEGRATION (REMOTE SITE)

a. ASF Integration Facility will receive the Integrated Pallet Assembly (IPA) and accomplish the following functions.

- (1) Perform receiving inspection by verifying interfaces to NASA approved documentation.

NOTE: If the IPA is from another remote site, the extent of the inspection may be total IPA checkout prior to mating with other pallet(s). If it is a local move, i.e., within the same site, the checkout may be minimal, such as visual inspection and basic continuity checks for power safety prior to integration.

- (2) Connect pallets and matched rail dolly frames together. The pallet/dolly assemblies become a structurally rigid assembly. This is similar to the configuration the pallets are in for flight in the payload bay of the STS Orbiter.

- (3) Connect the pallet/payload assembly to their interfaces with GSE in preparation for a full preflight type of functional test. This will require all payload (experiment) systems to be activated and supported only by GSE.
- (4) Following completion of the payload pallet integration, the payload will be prepared to be transported to the launch site.

1.7 PAYLOAD PALLET INTEGRATION (LAUNCH SITE)

a. ASF Launch Site will receive the payload and accomplish the following functions:

- (1) Perform receiving by, first, visual inspection and, second, by verifying the interfaces to NASA approved documentation.

NOTE: All ASF payloads may be handled in a similar manner, i.e., placed in a shipping container (payload canister) which is similar to the STS payload bay except that the matched rail handling dollies, less steerable wheels, remain assembled to the hardware until launch site integration tests are completed and the payload is installed in the STS Orbiter payload bay. See figures 5.2.2-4, 5.2.3-1, -2, and -3 in section 5 and figure E-1 of this appendix.

- (2) Perform integrated payload system tests.
- (3) When (2) is satisfactorily completed, install the payload handling frame over the upper half of the payload and transport the payload to the STS Orbiter preparation station for final loading preparations.
- (4) Disconnect the payload pallets from the handling dollies. Hoist the payload with the handling frame and lower the payload into the STS Orbiter payload bay. Connect the Orbiter interface support and functional connections, as required, for prelaunch test and checkout.

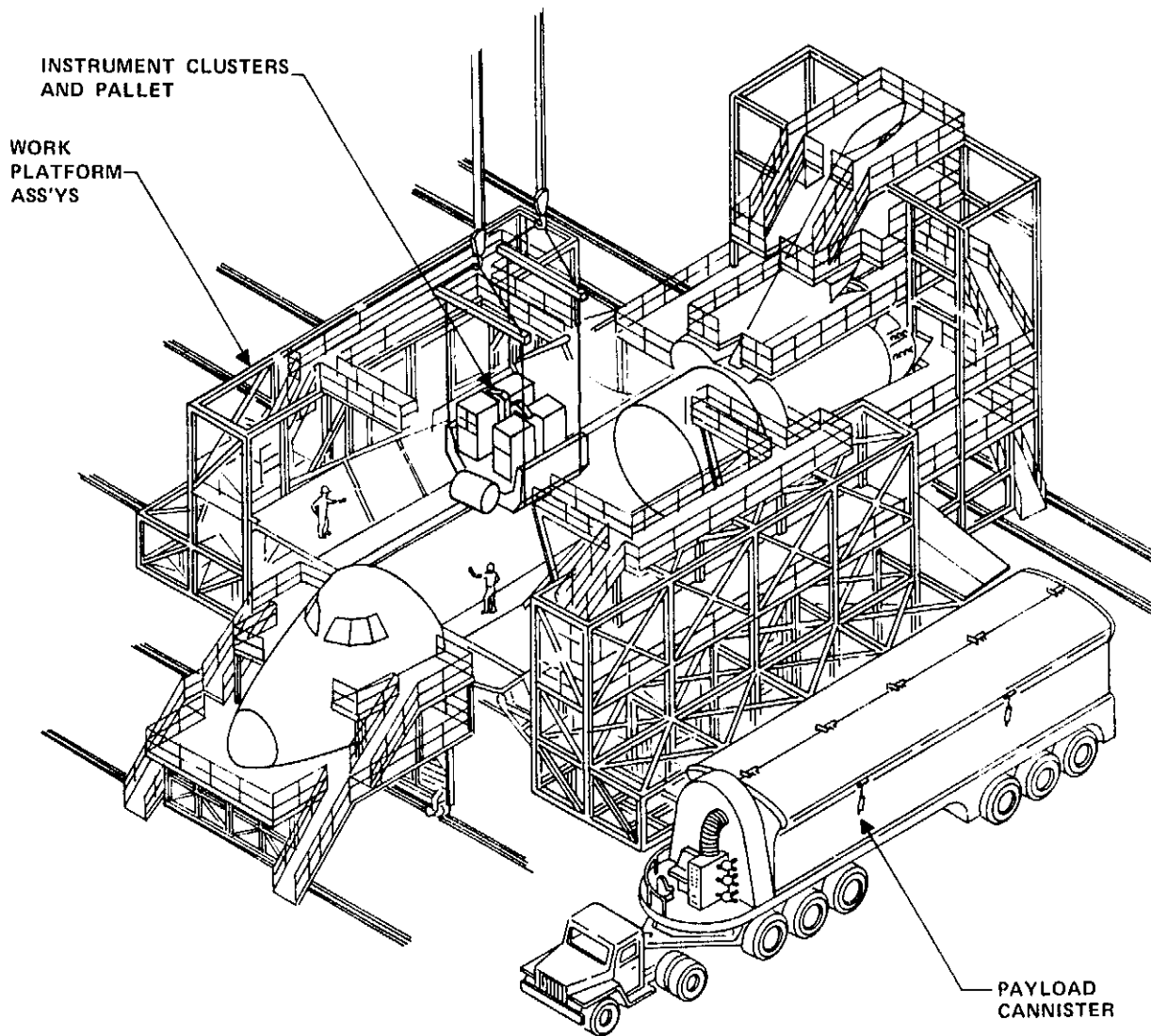

Figure E-1. - Payload installation and checkout facility.

- (5) Connect the STS Orbiter to the GSE via the umbilical interface and prepare to initiate prelaunch payload test and checkout activities.
- (6) When (5) is satisfactorily completed, perform prelaunch test and checkout to NASA approved documentation.
NOTE: The vehicle is in the horizontal orientation at this time and, probably, this is the last opportunity to perform realistic operations/tests of the payload subsystems prior to orbital operation. Every subsystem which can be feasibly exercised at this time should be operated through its required operational range. These one-g operations may well have different limits or equipment may require support to read orbital operational limits. Above all, realism of these operational and functional tests is important to the payload system operational test and checkout. It is understood that certain of the scientific operations and parameters are not totally verifiable in one-g and earth atmosphere environments; however, all the science supporting functions must be verified to assure the greatest probability of successful experiment operation.
- (7) When (6) is successfully completed, the payload is ready for checkout with the STS Orbiter hardware.
- (8) Perform the engineering functional tests of the payload from the Orbiter onboard test/monitoring complex. The GSE will remain attached to provide parallel, comparative monitoring and, as required, power and other facility support. Ultimately, verification of all flight hardware supporting the payload must be exercised as necessary to assure its capability to perform on station in orbit.
- (9) Remove the GSE except power and cooling equipment as required.
- (10) Prepare the payload for flight-type tests by making the payload configuration as close to flight as possible and perform the AMPS Final Payload Integration Test.

- (11) When (10) is successfully completed, the payload should be secured for orientation in the vertical position for launch.

1.8 ASF PAYLOAD FLIGHT INTEGRITY VERIFICATION

Prior to STS Orbiter launch, there are numerous integrity verification activities required, such as verifying that: (1) plumbing interfaces have been connected to GSE for hydraulic, cooling and vacuum; and (2) electrical power, command/control and data are secured and configured for flight and orbital operation. This verification is the logical termination of the ASF payload logistics activities and, properly done, is a single item in the STS launch countdown.

ASF payload flight integrity verification will be performed through the use of a detailed procedural checklist. The checklist will establish mechanical mating and securing of hardware/support equipment interfaces. The flight integrity of each instrument or cluster will be procedurally checked in a logical/chronological sequence, and functional and operation parameters may be measured as required. Some payload systems may require initialization to assure system integrity (of that system) in preparation for launch and, as required, will be accomplished by the flight integrity (procedure) checklist. In particular, verification of correct switch positions of the switches in the payload operational panels at the PSS station must be accomplished prior to launch and, preferably, as part of the payload checklist.

2.0 TRANSPORTATION

2.1 ASSUMPTIONS

The following assumptions were made.

- a. Multiple instrument manufacturers will exist.
- b. Two (2) or more IC/pallet integration sites exist.
- c. Two (2) payload integration sites, i.e., an IC/pallet integration site and a launch site exist.
- d. MGSE provides a basic frame on which to package and ship instruments and IC's. Pallets and payload require reusable containers which are also provided as MGSE.

2.2 INTRODUCTION

Transportation of ASF scientific payload hardware requires handling, packaging, and shipping procedures which will minimize or preclude contamination and extreme levels of environmental inputs or conditions with a maximum feasible usage of commercial packaging consistent with contamination and environmental requirements.

Transportation requirements for Orbiter payload have received considerable attention by the Marshall Space Flight Center with Martin Marietta performing a "Mission Support Equipment" study. Review of the output transportation recommendations of that study reveals that transportation modes or capabilities are largely provided by existing NASA aircraft.

2.3 DESIGN CONSIDERATIONS AND RECOMMENDATIONS

The pallet and payload handling (transporting) containers should incorporate the following design attributes.

- a. Top loading.
- b. "Clam shell" type doors.

- c. Compatible with pallet/handling dolly or payload/handling dollies configuration. less dolly wheels.
- d. Compatible with payload/pallet/dolly support structure.
- e. Minimum length to accommodate two integrated pallet/dolly assemblies.
- f. Maximum length to accommodate four integrated pallet/dolly assemblies.
- g. Compatible with horizontal transportation.

NOTE: Should be able to survive normal aircraft maneuvering attitudes.

NOTE: A two-pallet/dolly assembly handling/shipping container may be configured to hold one integrated assembly. Also, the four-pallet/dolly assemblies container may be used for a three-pallet integrated assembly configuration.

2.4 SHIPPING CONSIDERATIONS

For shipment of ASF payload instruments, consideration should be given to the utilization of the instrument handling frame provided by NASA as the basic MGSE frame to enable building a shock and vibration resistant commercial package. Thermal and humidity control by this package is not required; however, packaging should be made in an atmosphere controlled at $68^{\circ} \pm 10^{\circ}\text{F}$ ($20^{\circ} \pm 5^{\circ}\text{C}$) and humidity of not more than 50 percent. Shipment should be by special air carrier (contract) or NASA aircraft with cabin temperature and pressure control equivalent to commercial passenger service. If the above cannot be accomplished, then commercial insulated and limited-air-flow packaging should be used and the shipment made by courier/air freight.

Shipping containers which can control temperature and pressure should be provided by NASA for IC assemblies, pallet assemblies, and payload assemblies. This will maximize the flexibility of handling (shipping) conditions among the integrating and launch

sites and will optimize intransit environmental control of the hardware.

Special air carrier contract or NASA aircraft is recommended; however, air freight with special handling control is feasible for this level of hardware.

Consideration may be given to air-ride van for any hardware in the special containers, provided the shipment is made on STS dedicated van. This may be the recommended method for routine shipments as the program progresses and experience increases.