

N76-18532
**CASE FILE
COPY**

NASA CR-144915

**PRELIMINARY WEIGHT AND COSTS
OF SANDWICH PANELS TO DISTRIBUTE
CONCENTRATED LOADS**

G. Belleman and J.E. McCarty

February 15, 1976

**Prepared under contract NAS1-13338 by
The Boeing Company
P.O. Box 3707
Seattle, Washington 98124**

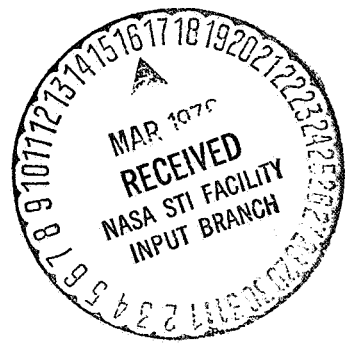

**for
NATIONAL AERONAUTICS AND SPACE ADMINISTRATION
WASHINGTON, D.C. 20546**

1. Report No. NASA CR-144915	2. Government Accession No.	3. Recipient's Catalog No.	
4. Title and Subtitle PRELIMINARY WEIGHT AND COSTS OF SANDWICH PANELS TO DISTRIBUTE CONCENTRATED LOADS		5. Report Date February 1976	6. Performing Organization Code
		8. Performing Organization Report No. D6-42680	
7. Author(s) G. Belleman and J.E. McCarty		10. Work Unit No.	
9. Performing Organization Name and Address The Boeing Company Seattle, Washington 98124		11. Contract or Grant No. NAS1-13338	
		13. Type of Report and Period Covered Contractor Report	
12. Sponsoring Agency Name and Address National Aeronautics and Space Administration Washington, D.C. 20546		14. Sponsoring Agency Code	
		15. Supplementary Notes	
16. Abstract <p>Minimum mass honeycomb sandwich panels were sized for transmitting a concentrated load to a uniform reaction through various distances. The nonuniform skin gages were fully stressed with a finite element computer code. The panel general stability was evaluated with a buckling computer code labeled STAGS-B. Two skin materials were considered; aluminum and graphite-epoxy. The core was constant thickness aluminum honeycomb. Various panel sizes and load levels were considered. The computer-generated data were generalized to allow preliminary least mass panel designs for a wide range of panel sizes and load intensities. An assessment of panel fabrication cost was also conducted. Various comparisons between panel mass, panel size, panel loading, and panel cost are presented in both tabular and graphical form.</p>			
17. Key Words (Suggested by Author(s)) Panel mass Quasi-isotropic Sandwich panels Fully stressed Master panels Finite element Graphite-epoxy STAGS-B		18. Distribution Statement Unclassified—unlimited	
19. Security Classif. (of this report) Unclassified	20. Security Classif. (of this page) Unclassified	21. No. of Pages 96	22. Price*

FOREWORD

This report was prepared by The Boeing Company under NASA contract NAS1-13338 and covers the work period July 1974 through September 1975. The contract was monitored by Dr. Martin Mikulas of the Structures Division, NASA Langley Research Center.

The authors wish to acknowledge the significant contribution of Mr. John Laakso of The Boeing Aerospace Company. Mr. Laakso conducted all of the computer analysis required in this study.

CONTENTS

	Page
SUMMARY AND INTRODUCTION	1
SYMBOLS AND ABBREVIATIONS	3
SANDWICH PANEL ANALYSIS	6
Strength-Mass Analysis	6
Buckling Analysis	8
Compression Panel Analysis	13
Shear Panel Analysis	13
Panel Stress Analysis	15
SANDWICH PANEL DATA	20
Compression Panel Data	20
Shear Panel Data	29
Cost Data	35
MASS AND COST COMPARISON	37
PANEL PRELIMINARY DESIGN PROCEDURE	54
Preliminary Design Problem: Example 1	61
Preliminary Design Problem: Example 2	63
CONCLUSIONS	71
APPENDIX A—MATERIAL AND FIBER PROPERTIES	72
APPENDIX B—STRENGTH/MASS COMPUTER DATA, EXAMPLE	73
APPENDIX C—TEST PANEL DESIGN AND FABRICATION	89
Test Panel Fitting Check	93
Compression Panel Buckling Check	94
Shear Panel Buckling Check	95
APPENDIX D—PANEL FABRICATION COST BREAKDOWN, SAMPLE	96

FIGURES

No.		Page
1	Finite Element Skin Plate Model	7
2	Computer Convergence to a Fully Stressed Plate	9
3	Relationship of Buckling Load to Core Depth	10
4	Relationship of Buckling Load to Panel Size	12
5	Relative Bending Strain Energy Distribution by STAGS-B Analysis	14
6	Intracell Buckling Allowable	16
7	Core Shear Crimping Allowable	17
8	Data Bank Loading Code Schematic	24
9	Skin Gage Comparison of Different Size Compression Panels	25
10	Relative Total Panel Mass Versus Skin-to-Core Mass Ratio	28
11	Ply Layup for a Panel Having Optimized Fiber Orientation	30
12	Skin Mass Penalty for Aluminum-Faced Compression Panels Having Total-Facing Minimum Gage of 0.406 mm	31
13	Skin Mass Penalty for Graphite-Faced Compression Panels Having Total Facing Minimum Gage of 1.02 mm	32
14	Skin Mass Increase Required for Aluminum-Faced Compression Panels Having Total Facing Minimum Gage of 0.406 mm	33
15	Skin Mass Increase Required for Graphite-Faced Compression Panels Having Total Facing Minimum Gage of 1.02 mm	34
16	Graphite-Epoxy Cost Projection	36
17	Fitting-Mass Factor Versus Panel Area for Aluminum-Faced Compression Panels	41
18	Fitting-Mass Factor Versus Panel Area for Graphite-Faced Compression Panels	42
19	Total Mass of Various Sized Panels with Aluminum and Graphite Skins—No Minimum-Gage Constraints	43
20	Total Mass of Various Sized Panels with Aluminum and Graphite Skins—With Minimum-Gage Constraints	44
21	Panel Mass Versus Panel Size—No Minimum-Gage Constraints	45
22	Panel Mass Versus Panel Size—With Minimum-Gage Constraints	46
23	Relative Efficiencies of Aluminum and Graphite Compression Panels—No Minimum-Gage Constraints	48
24	Relative Efficiencies of Aluminum and Graphite Compression Panels—With Minimum-Gage Constraints	49
25	Cost of Each Kilogram Saved by Use of Graphite Instead of Aluminum Skins on Compression Panels—No Minimum-Gage Constraints	50
26	Cost of Each Kilogram Saved by Use of Graphite Instead of Aluminum Skins on Compression Panels—With Minimum-Gage Constraints	51
27	Cost Per Panel (for 50 Units) for Various Area Panels Having Aluminum and Graphite Skins	52
28	Master Panel Skin Gage Distribution for Aluminum 7075-T6 Skins	55
29	Master Panel Skin Gage Distribution for Intermediate Strength Graphite Skins	64
B-1	Finite Element Model, Skin Gage Distribution	74
B-2	Finite Element Model, Plate Stresses	77

FIGURES (Concluded)

No.		Page
B-3	Typical Distortion Pattern (Exaggerated)—Graphite-Compression	80
B-4	STAGS-B Model, Skin Gage Input (Total) in Millimeters	81
B-5	Finite Element Model, Skin Gage Distribution	83
B-6	Finite Element Model, Plate Stresses	86
C-1	Skin Gage Layout, Compression Test Panel	90
C-2	Skin Gage Layout, Shear Test Panel	90
C-3	Graphite Shear Test Panel	91
C-4	Graphite Compression Test Panel	92

TABLES

No.		Page
1	Optimized Panel Skin Masses—Aluminum	21
2	Optimized Panel Skin Masses—Graphite ^a	22
3	STAGS-B Buckling Loads	23
4	Compression Panel Cost in Fabrication Man-Hours	35
5	Compression Panel Mass and Cost Data Summary for Load of 222.4 kN	38
6	Compression Panel Mass and Cost Data Summary for Load of 444.8 kN	39
7	Compression Panel Mass and Cost Data Summary for Load of 889.6 kN	40
8	Shear Panel Mass Summary	47
9	Compression Panel Cost/Mass Comparison	53

PRELIMINARY WEIGHT AND COSTS OF SANDWICH PANELS TO DISTRIBUTE CONCENTRATED LOADS

G. Belleman and J. E. McCarty
The Boeing Company

SUMMARY

An analytical investigation was conducted to examine techniques of sizing honeycomb sandwich panels for distributing a concentrated compression load to a uniform compression or shear reaction. Aluminum and graphite-epoxy materials were considered for face materials. The panel sizing approach developed allows preliminary design of fully stressed panels for various loads, panel sizes, and panel aspect ratios. The results of this investigation have application to aerospace structures such as the space shuttle and space tug.

Along with proposed panel sizing techniques, estimates of panel cost for the various materials are provided in this report. These data provide a base for cost/mass trade comparisons.

It was found that finite element computer solutions to the fully stressed panel skin thicknesses were a "unit" solution. This feature allows a single "master panel skin gage distribution topography" to be used for the design of similar aspect ratio panels by the ratio technique. The procedure permits a broad range of preliminary design application to panels of various sizes and loadings from a relatively small amount of computer data.

A data bank of panel skin mass, skin thickness, and general instability loads has been generated for use as baseline cases. Techniques of extending these baseline data to other cases are presented.

Several comparisons between panel mass, panel size, panel loading, and panel cost are presented in tabular and graphical form.

INTRODUCTION

A classical problem in structural engineering is how best to transmit a load through a defined space in an efficient and cost-effective manner. There are typically several possible structural solutions to this problem. Some of the structural candidates are trusses, plates, panels, and beams. Many studies on these various arrangements have been conducted for specific applications. This study selects one structural arrangement and examines it in a more general manner; specifically, honeycomb sandwich panels. The ground rule for the study is that the load is introduced in concentrated fashion and transmitted to a uniformly distributed compression reaction or a shear reaction.

Sufficient analytical information on the selected structural concept is provided in this study to allow preliminary designs of least mass sandwich panels. An insight is also provided as to the cost of those panels. The study results have possible application to a variety of light-weight aerospace structures, such as the space tug structure.

This study approaches the problem by using a finite element computer program which fully stresses all panel skin elements. Another linear bifurcation theory computer program assesses the panel general stability. A load-fitting mass is estimated and the entire panel mass including the facings, core, and fitting is summed. Two facing materials are considered; aluminum and graphite-epoxy composite. The core is considered to be aluminum hexagonal honeycomb and is considered to have uniform thickness. Aluminum and titanium are considered for the load fittings but are not included in the computing analysis. The load range examined was predominantly in the vicinity of 175.1 kN/m. Specific applications for 87.6, 175.1, and 350.2 kN/m are presented. Techniques of extrapolating results to other load ranges are developed. Transmission of load over varying distances is considered, with panels having aspect ratios of 0.25, 0.50, and 1.0 selected for primary investigation. Major emphasis was placed on the panels reacting the concentrated load with a uniform compression loading, but shear reactions were also investigated. Panel fabrication cost data were generated to allow cost/mass comparisons.

The data generated on skin gage, mass, cost, and design procedure are presented in both tabular and graphical formats.

Two small (305.8- by 305.8-mm) panels were designed and fabricated as examples of the design procedure. One of the panels was designed for a compression reaction and the other for a shear reaction.

The data presented allow preliminary sizing of honeycomb sandwich panels to transmit a structural load over a given distance. The resultant honeycomb sandwich panel will approach least mass for the specified application. The data allow the preliminary designer to assess nonoptimum mass penalties, such as minimum gage constraints, if he so desires.

The cost data allow the preliminary designer to assess the dollar cost for both a small number of fabricated units (1) and a larger number of units (50).

SYMBOLS AND ABBREVIATIONS

A	area, m ²
AL	abbreviation for aluminum
AR	panel aspect ratio
b	plate thickness, m
c	core thickness, mm
d	distance between sandwich panel skin centroids, mm
D	bending stiffness
E	modulus of elasticity, Pa
E _{AL}	modulus of elasticity, aluminum, Pa
E _c	core compression modulus, Pa
E _{GR}	modulus of elasticity, graphite, Pa
E _x	longitudinal modulus, Pa
E _y	transverse modulus, Pa
f _{br}	bearing stress, Pa
F _c	elastic compression stress limit, Pa
F _{CR}	face wrinkling stress, Pa
F _{cx}	longitudinal compression ultimate stress, Pa
F _{cy}	transverse compression yield stress, Pa

f_s	adhesive shear stress, Pa
F_s	elastic shear stress limit, Pa
F_t	elastic tensile stress limit, Pa
F_{tx}	longitudinal tensile ultimate stress, Pa
F_{ty}	transverse tensile yield stress, Pa
F_x	longitudinal allowable stress, Pa
F_y	transverse allowable stress, Pa
G	shear modulus, Pa
G_{AL}	shear modulus, aluminum, Pa
G_{GR}	shear modulus, graphite, Pa
G_L	core longitudinal shear modulus, Pa
GR	abbreviation for graphite
h	panel height, m
HMG	high modulus graphite
HSG	high strength graphite
I	moment of inertia
ISG	<i>intermediate strength graphite</i>
K_{CR}	buckling coefficient
N_{CR}	core shear crimp load, N/m
N_x	applied compression edge load, N/m

N_{xCR}	critical compression buckling load, N/m
P	applied load, N
Q	first area moment
Q_x	applied shear reaction load, N/m
Q_{xCR}	critical shear buckling load, N/m
s	core cell size, m
$s.s$	simply supported edges
t	skin thickness, m
t_{min}	minimum skin thickness, m
V	shear load
w	panel width, m
μ	Poisson ratio
ρ	density, kg/m ³
σ_x	longitudinal stress, Pa
σ_y	transverse stress, Pa
τ_{xy}	shear stress in x-y plane, Pa

SANDWICH PANEL ANALYSIS

STRENGTH-MASS ANALYSIS

A finite element computer code called "ATLAS" was used for panel skin sizing. The resize module used with this program fully stresses each element of the panel. The stress limitations placed on resize were that the stresses would be in the elastic regime and would not exceed the Hill-Von Mises strength criteria for the limiting elastic stress. The graphite-epoxy faces were, in all but two cases, restricted to quasi-isotropic elastic properties for equal layers of 0°, +45°, -45°, and 90° ply orientation. The two exceptions were analyzed as fiber-failure oriented. The material properties used in the ATLAS program are listed in appendix A. Many variations of allowable data exist for graphite-epoxy composites. Users of this study's data who have other allowable values will find some variance with the results herein. The allowables used in this study are believed to be in reasonable agreement with other sources and therefore quite adequate for the preliminary design approach of this study.

The same finite element model (fig. 1) was used for both the compression- and shear-reacted panels. The model is for one-half the panel width since a state of symmetry exists about the panel vertical centerline. All edges were restricted to no out-of-plane distortion. The centerline edge was further restricted to no horizontal inplane distortion. Other edges were allowed both horizontal and vertical deflection. The panel edge fixity thus resulted in panel behavior similar to a center-loaded beam. The loads were applied to appropriate nodal points and the computer resolved the balancing loads. The program automatically computed, the nodal coordinates appropriate to the panel size input.

The skins were sized by modeling them as a flat plate; that is, the two sandwich faces were assumed as acting together. The finite element program treated both faces as if they were combined into a plate thickness. The initial skin gage input to the computer was a uniform 50.8 mm. The computer program selectively reduced each plate element thickness until a fully stressed condition existed. The computer skin gage output was, therefore, the sum of both sandwich skins. The computer program output was the total skin mass, the thickness of each plate element, the nodal displacements, and the plate stresses in the panel axes.

The failure criteria applied by the computer to the maximum plate stresses was the Hill-Von Mises distortion energy theory in the form of:

$$\left[\left(\frac{\sigma_x}{F_x} \right)^2 - \left(\frac{F_y}{F_x} \right) \left(\frac{\sigma_x}{F_x} \right) \left(\frac{\sigma_y}{F_y} \right) + \left(\frac{\sigma_y}{F_y} \right)^2 + \left(\frac{\tau_{xy}}{F_s} \right)^2 \right]^{1/2} \leq 1$$

The computer calculated the stress levels at each nodal point and output the average stress on the plate circumscribed by the appropriate three or four nodes. The failure was applied to these average plate stresses. The computer selected the appropriate allowable stress, if there was a difference for tension and compression, by assessing the algebraic sign associated with the stress level.

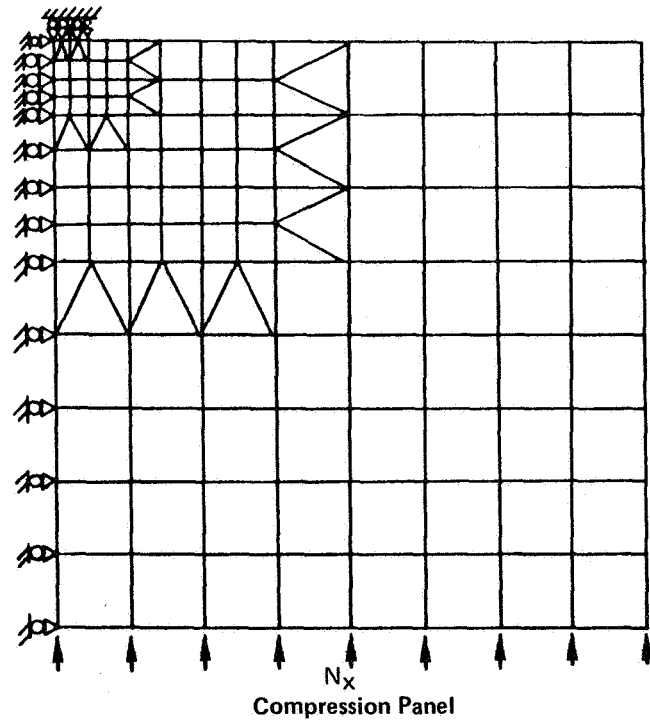
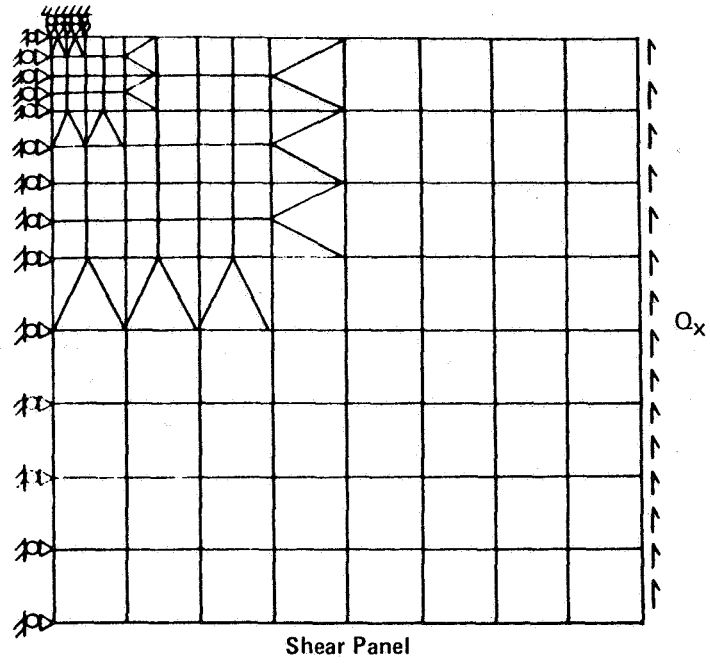

Figure 1.—Finite Element Skin Plate Model

Plate stresses of triangular elements having more than one boundary leg not in the orthogonal panel axis must be used with care. The computer program automatically assumes that the first leg input is one of the panel axes. If they are not input properly, the stresses output will not necessarily be in the panel axes reference system. This is thought to have occurred on some of the small triangular elements.

A typical iteration sequence of the ATLAS program is shown in figure 2.

BUCKLING ANALYSIS

The computer program used for general stability was the NASA-generated, linear bifurcation theory, STAGS-B code. The model for this program divided the panel into uniform nine rows and nine columns. Each of the 81 skin plates generated could be assigned an individual plate thickness.

The 81 plate models were found to be moderately expensive in terms of computer time. A preliminary design technique was developed so that uniform gage baseline buckling data on aluminum panels could be extrapolated to nonuniform gage panels of either aluminum or graphite.

Out-of-plane displacements were allowed on the panel \bar{C} edge but not on the remaining simply supported edges.

An arbitrary starting load was assigned to the reaction edges. The program, by linear bifurcation theory, output the eigenvalue that factored the starting load to the buckling load. Nodal displacements and rotations were also output. All buckle solutions in this study indicated simple buckle patterns, and complex, high-order solutions were not encountered. The baseline core thickness input was a uniform 25.4-mm thickness with checkpoints made for other thicknesses.

It was quickly found in the buckling analysis that the buckling load for two panels of equal skin thickness but different core thicknesses is directly proportional to the core thickness squared. This was expected since the generalized classical buckling equation $N_{xCR} \propto K_{CR}D/h^2$ indicates the buckling load to be proportional to the bending stiffness D . This stiffness for a sandwich panel is proportional to the panel moment of inertia I . The moment of inertia for a sandwich panel is $I = td^2/2$. This indicates, then, that the buckling load is proportional to the core depth squared, and this is what was found. Figure 3 shows a plot of the data demonstrating this relationship. This is a useful observation, for it is now possible to establish computer buckling loads for a unit core depth and correct the buckling load for other core depths by this relationship.

A further relationship to consider is the h^2 term in the generalized buckling equation. It is well known that the buckling coefficient K_{CR} is a function of panel aspect ratio. This suggests that if various panel aspect ratios are analyzed with the STAGS-B buckling analysis, the resultant buckling load has the K_{CR} built into the answer. This realization allows corrections to be made for other panels having the same aspect ratio but different overall size. The inverse ratio of h^2 between the panels provides this correction. Checkpoints were established to verify this relationship for both the compression-reacted case and the shear-reacted case. The skins were a constant gage (0.51 mm) graphite epoxy. One panel for each

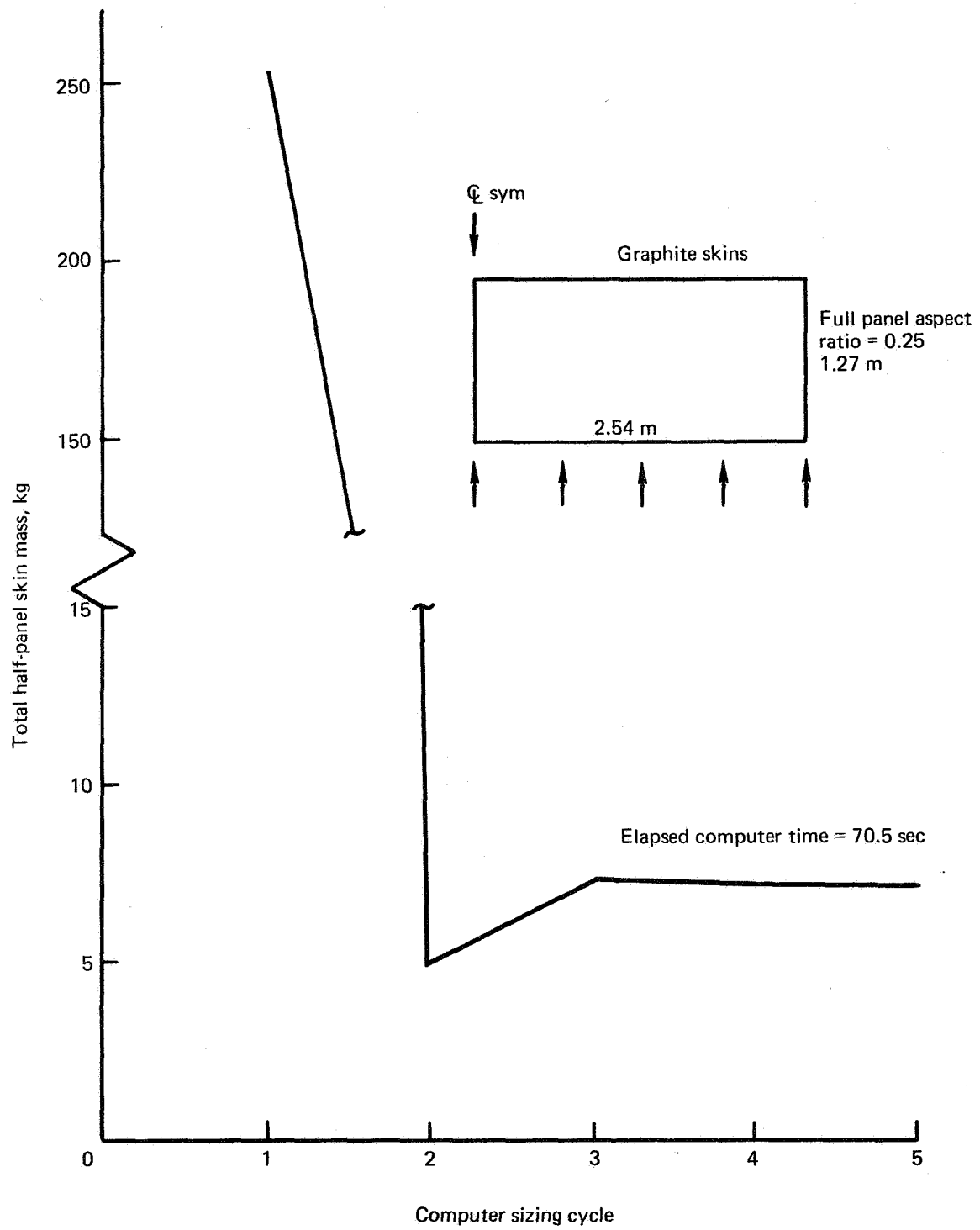

Figure 2.—Computer Convergence to a Fully Stressed Plate

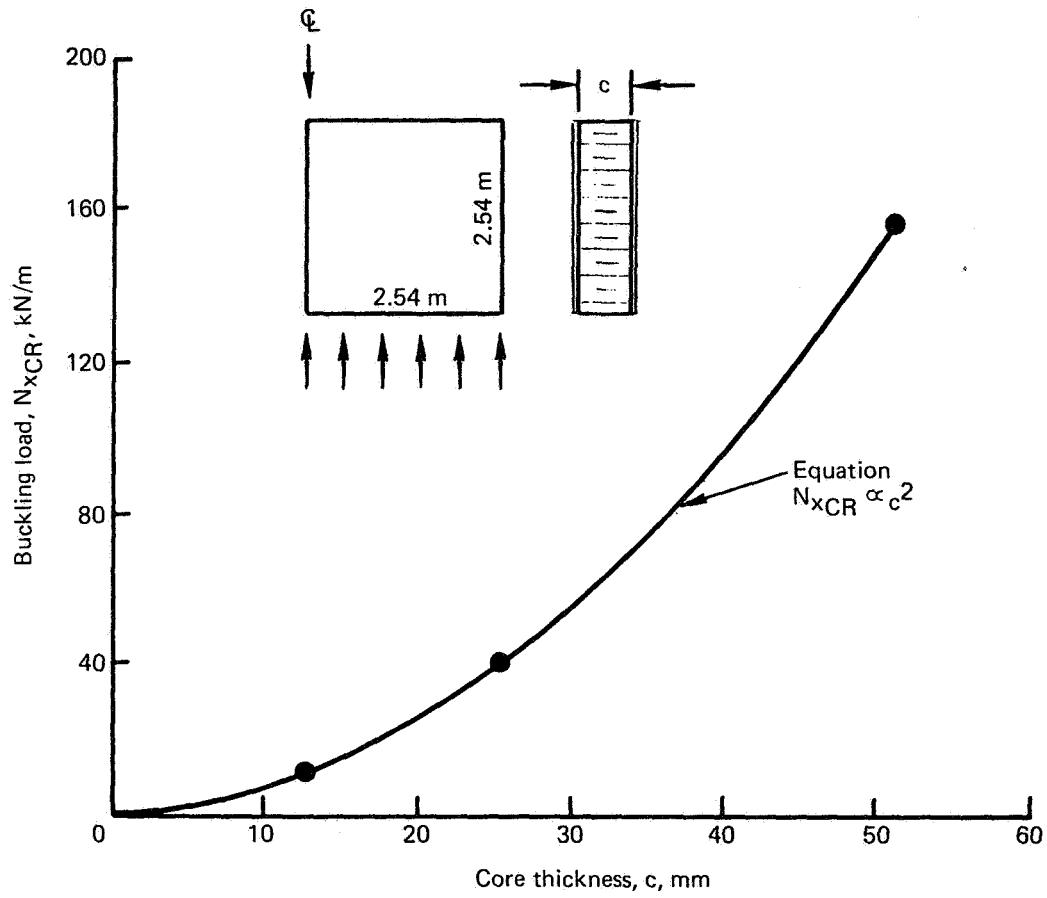

Figure 3.—Relationship of Buckling Load to Core Depth

case had half-width dimensions of 2.54 by 2.54 m and the comparison panel, 1.27 by 1.27 m. The buckling load for the smaller panels was almost exactly four times the larger panels, demonstrating the h^2 relationship to buckling load. Figure 4 shows the plot of these comparisons. It is now possible to relate the STAGS-B generated buckling loads on baseline panels to other configurations by the appropriate ratios of core thickness, skin thickness, and panel size.

Another relation to consider is the skin modulus of elasticity. The classical buckling equation indicates the buckling load to be directly proportional to skin modulus. It also indicates the buckling load to be directly proportional to skin thickness for a sandwich panel since the bending stiffness D is directly proportional to the moment of inertia I . An example taken from the STAGS-B data bank indicates the linear ratio extrapolation possibilities for these two variables.

The STAGS-B data bank shows that an aluminum faced panel having dimensions of 2.54 by 2.54 m (half-panel width), a skin thickness of 1.02 mm, and a uniform compression reaction will buckle at 39.40 kN/m. Ratioing this buckling load to a graphite panel with a skin gage of 0.51 mm, the following solution to this case exists.

$$(39.40) \left(\frac{45.51}{71.02} \right) = 25.25 \text{ kN/m} \quad (\text{ratio of skin } E)$$

$$(25.25) \left(\frac{0.51}{1.02} \right) = 12.63 \text{ kN/m} \quad (\text{ratio of skin } t)$$

Actual STAGS-B buckling load solution for this graphite panel is 12.10 kN/m.

Extrapolation error is approximately 4%, sufficiently accurate for preliminary design.

A similar exercise for shear-reacted panels in the STAGS-B data bank indicates extrapolation errors of approximately 13%. This error is largely unexplained but is believed partly due to the nonproportional G-to-E ratios of the two materials. This error is still considered quite acceptable for preliminary design techniques, since very small core thickness correction is necessary to account for buckling load estimate errors of that magnitude. Another example of this approach is the comparison of two graphite-skinned panels in the STAGS-B data bank. They both have compression-type reactions and have half-width dimensions of 2.54 by 2.54 m. One panel was analyzed for a constant skin gage of 0.51 mm and the other used actual master panel gages applied to a 9- by 9-element grid composing the STAGS-B model. It was found that the predominant buckling action occurs on the panel centerline. Figure 5 indicates the relative strain energy of the buckled compression panel. An approximate buckling load prediction was thought possible if the minimum skin gage occurring on the panel centerline was assumed to be the panel's uniform skin gage. The actual minimum centerline skin gage used in the STAGS-B model was 0.38 mm. A constant skin gage of 0.51 mm in the STAGS-B data bank indicates a buckling load of 12.1 kN/m. By ratioing the minimum skin gages on the panel centerline, a predicted buckling load of $0.38/0.51 (12.1) = 9.04$ kN/m is estimated. The actual STAGS-B buckling load is 10.2 kN/m. The estimated buckling load is sufficiently close for preliminary design. Considerable baseline data are presented for uniform gage aluminum panels which may be used for extrapolations.

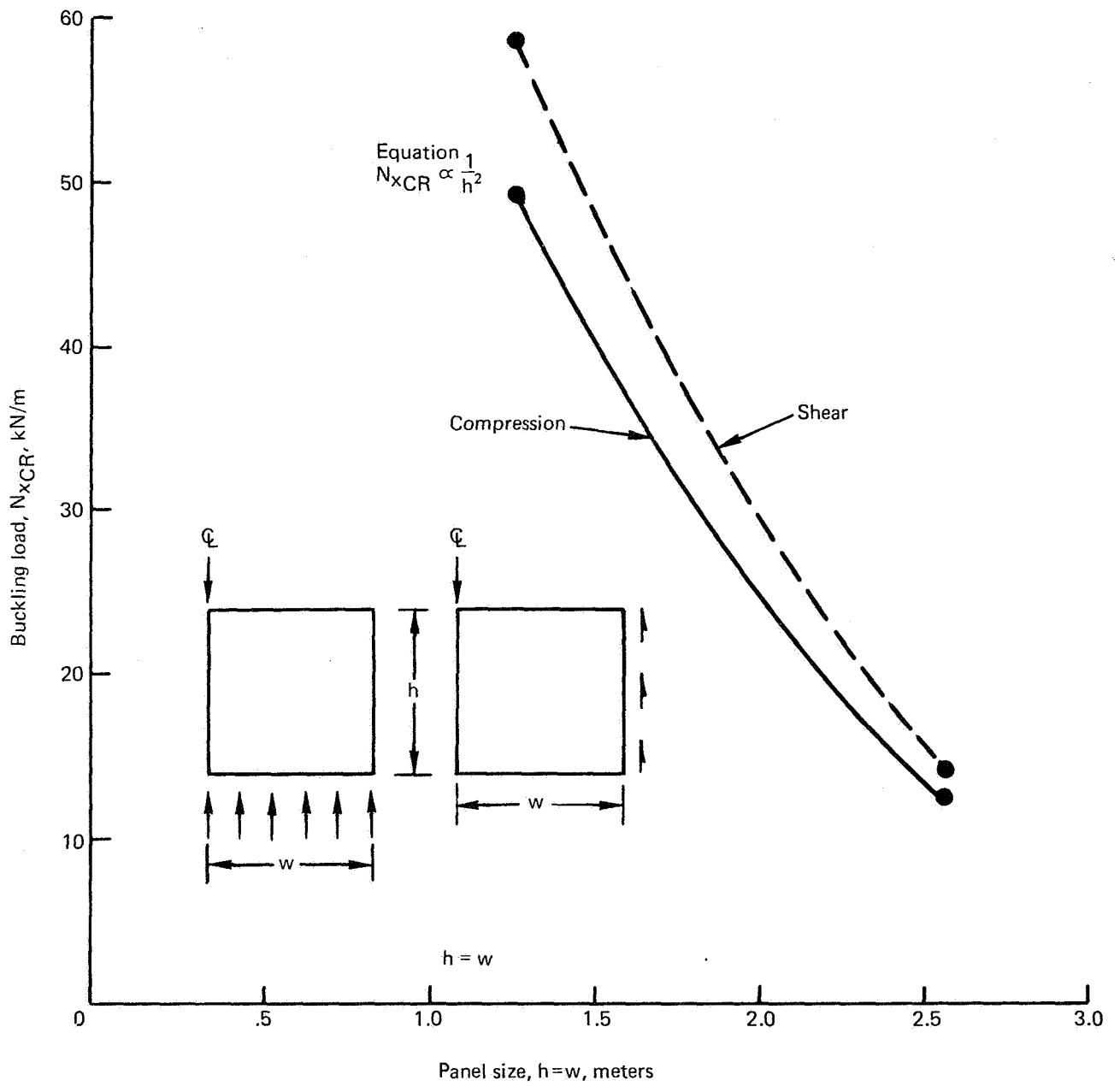

Figure 4.—Relationship of Buckling Load to Panel Size

COMPRESSION PANEL ANALYSIS

The compression panels were modeled with the finite element model previously discussed. The model remained the same for the various aspect ratio panels. The peripheral coordinates were input to the computer program, and the nodal coordinates were automatically computed. A uniform compression loading was input to the panel edge. The computer then sized the elements for a full elastic stress state and computed the balancing loads. The element stresses were calculated in the panel axes. Nodal deflections were also calculated. The skin thicknesses for each plate element were included in the printout.

It was found that panels having the same aspect ratio but different sizes had the same skin gages for the same distributed load. This observation demonstrated that a unit solution was being obtained. It was then apparent that the range of analytical data could be extended to other load ranges and panel sizes by simply ratioing a baseline panel skin gage distribution by the load ratio to that used on the baseline. Accordingly, three aspect ratio panels (0.25, 0.50, and 1.0) were established as master panel skin gage distribution baselines. The unitized loading was 175.1 kN/m. Minimum-gage constraints were not placed on these panels since the effects of this nonoptimum parameter may be subsequently evaluated as desired.

Loads as high as 5.25 MN/m were evaluated early in the program. These loads were found to be unrealistically high because skin gages could become as thick as 254 mm, which is out of the range of practical honeycomb panel usage. The unit solution approach allows extrapolation of the test data to loads other than the 175.1 kN/m, but it is suggested that skin gages be kept in a reasonable range such as below 20 mm for each skin.

SHEAR PANEL ANALYSIS

The model used for the shear panels was the same as that for the compression panels except for the type of loading. Again, only a half-panel width was modeled since the shear panels are also symmetric about their vertical centerline. As in the compression panels, it was found early in the program that very large loads resulted in impractical skin thicknesses. It was found that the shear panel skin distribution was also a unit solution and skins could be sized by load ratios to the baseline. The unitized baseline load was 175.1 kN/m on the average but was a parabolic distribution rather than uniform. Refer to the following sketch.

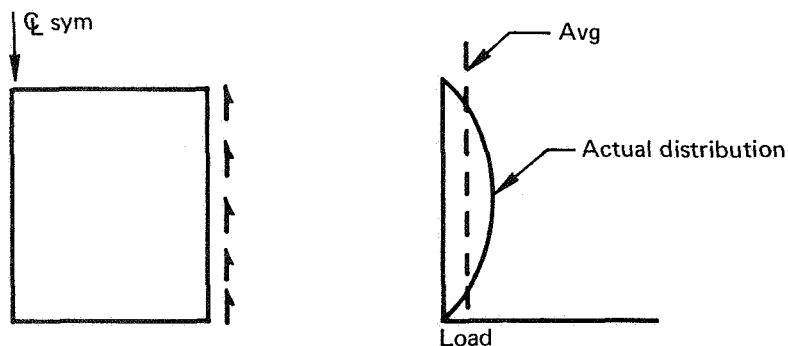

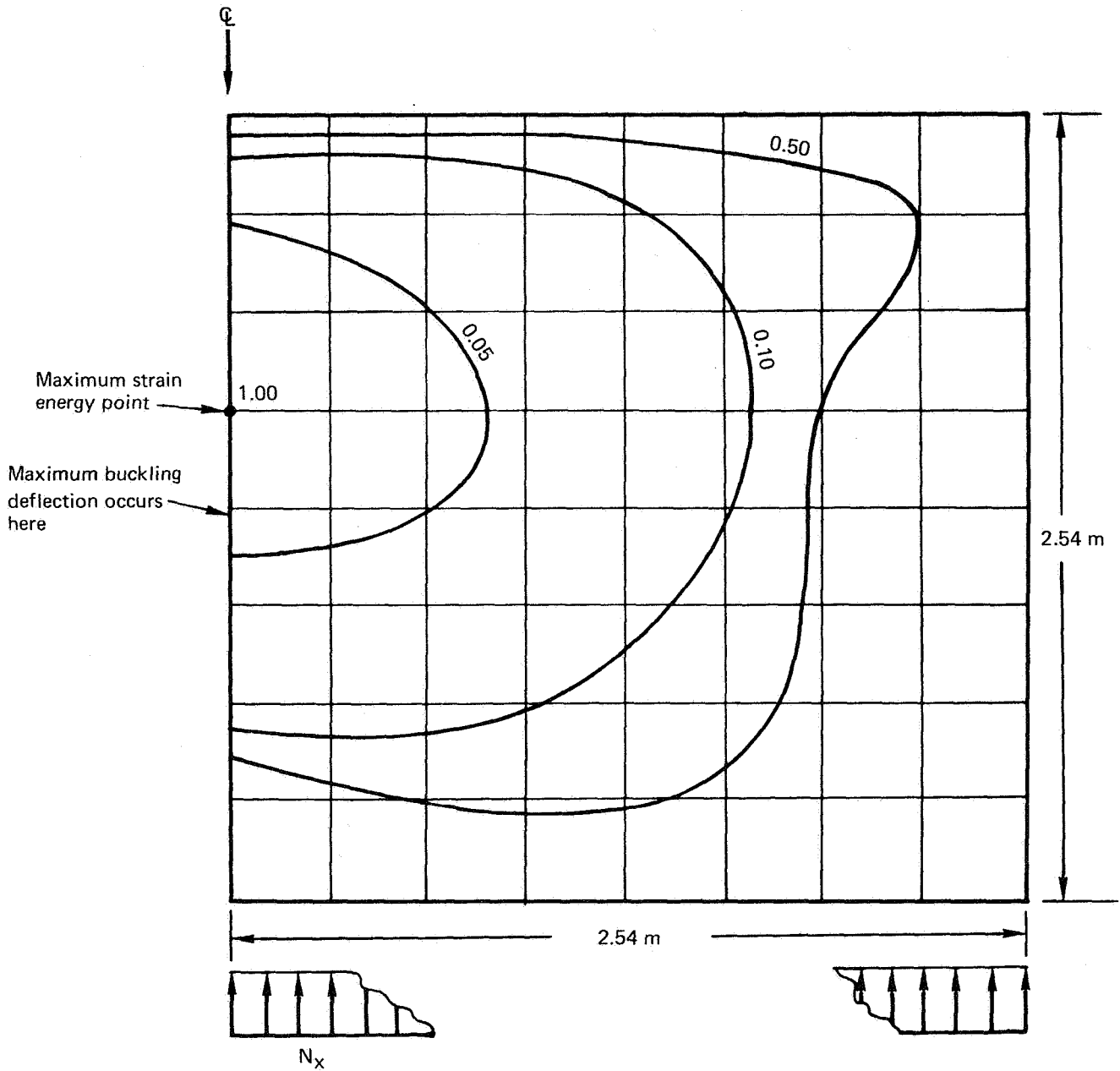

Figure 5.—Relative Bending Strain Energy Distribution by STAGS-B Analysis

Attempts to provide analytical solutions to a uniform shear load were unsuccessful. Due to the inplane bending capability of the plate elements, the only shear distribution possible is the classical VQ/Ib parabolic distribution.

As for the compression-reacted panels, three aspect ratios (0.25, 0.50, and 1.0) were selected from the shear load cases to represent the master skin gage distribution panels. Again, the unit solution concept with master panel data may be used to size panel skin gages for various loadings and panel dimensions. The shear panel skin gage distributions are considerably more complex than the compression panel skin distributions.

PANEL STRESS ANALYSIS

The ATLAS computer program sizes the skin gages so that no plate elements have principal stresses greater than the input elastic stress limit. The STAGS-B program assesses the general instability. The other types of possible panel failure are intracell skin buckling, core shear crimping, and face wrinkling.

The equation used for intracell skin buckling is

$$F_{CR} = E \left[\frac{\pi^2}{3(1 - \mu^2)} \right] \left[\frac{t}{s} \right]^2$$

By using the maximum allowable stress, figure 6 can be developed. It is seen that minimum-gage aluminum of 0.20 mm may be worked up to 327.5 MPa with a 5.84-mm core cell size. Similarly, the minimum-gage graphite of 0.51 mm may be worked up to 427.8 MPa on a 10.2-mm-core cell size. Since the maximum typical cell size considered is 4.76 mm, intracell buckling is no problem for the minimum gages and maximum stress levels used in this study.

The equation $N_{CR} = 0.75 d^2/C G_L$ was used to develop the core shear crimping curves of figure 7. This figure will provide a quick check on a panel's susceptibility to this failure mode. It is noticed that a typical minimum core density of 49.63 kg/m³ will stabilize the panel up to 4.20 MN/m for minimum skin gages which cause the parameter $d^2/c \rightarrow 1$. This load well exceeds the range of this study, so shear crimping is not a critical failure mode for panels in this study.

The formula for sandwich face wrinkling includes both core crushing and face separation and is expressed as:

$$F_{CR} = 0.60 (E G_L E_c)^{1/3}$$

By substituting the maximum allowed stresses in the panels and the associated skin moduli, the following minimum parameters necessary to preclude face wrinkling are found:

$$\begin{aligned} G_L E_c &= 7986 \text{ TPa}^2 \quad \text{for graphite faces} \\ G_L E_c &= 2234 \text{ TPa}^2 \quad \text{for aluminum faces} \end{aligned}$$

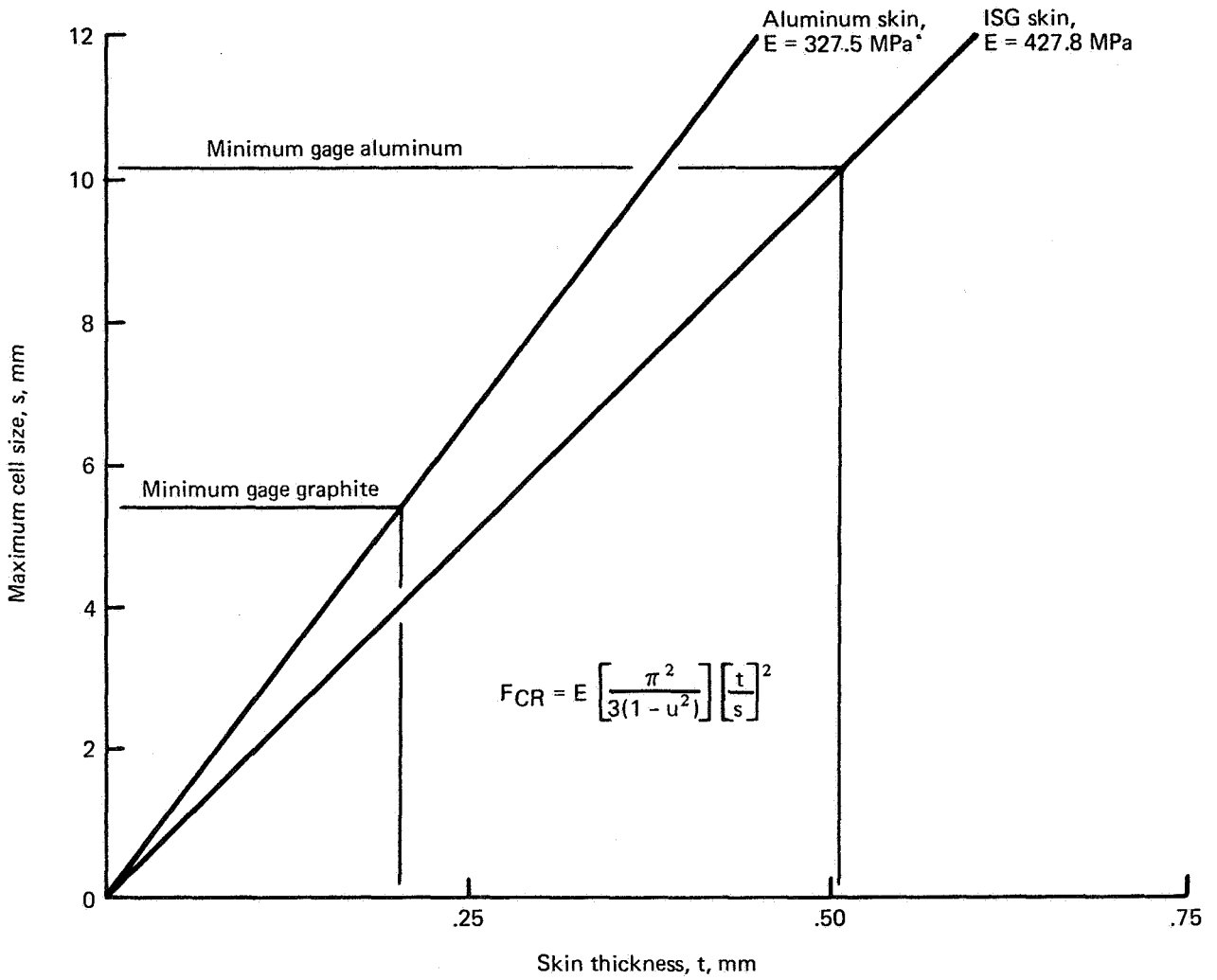

Figure 6.—Intracell Buckling Allowable

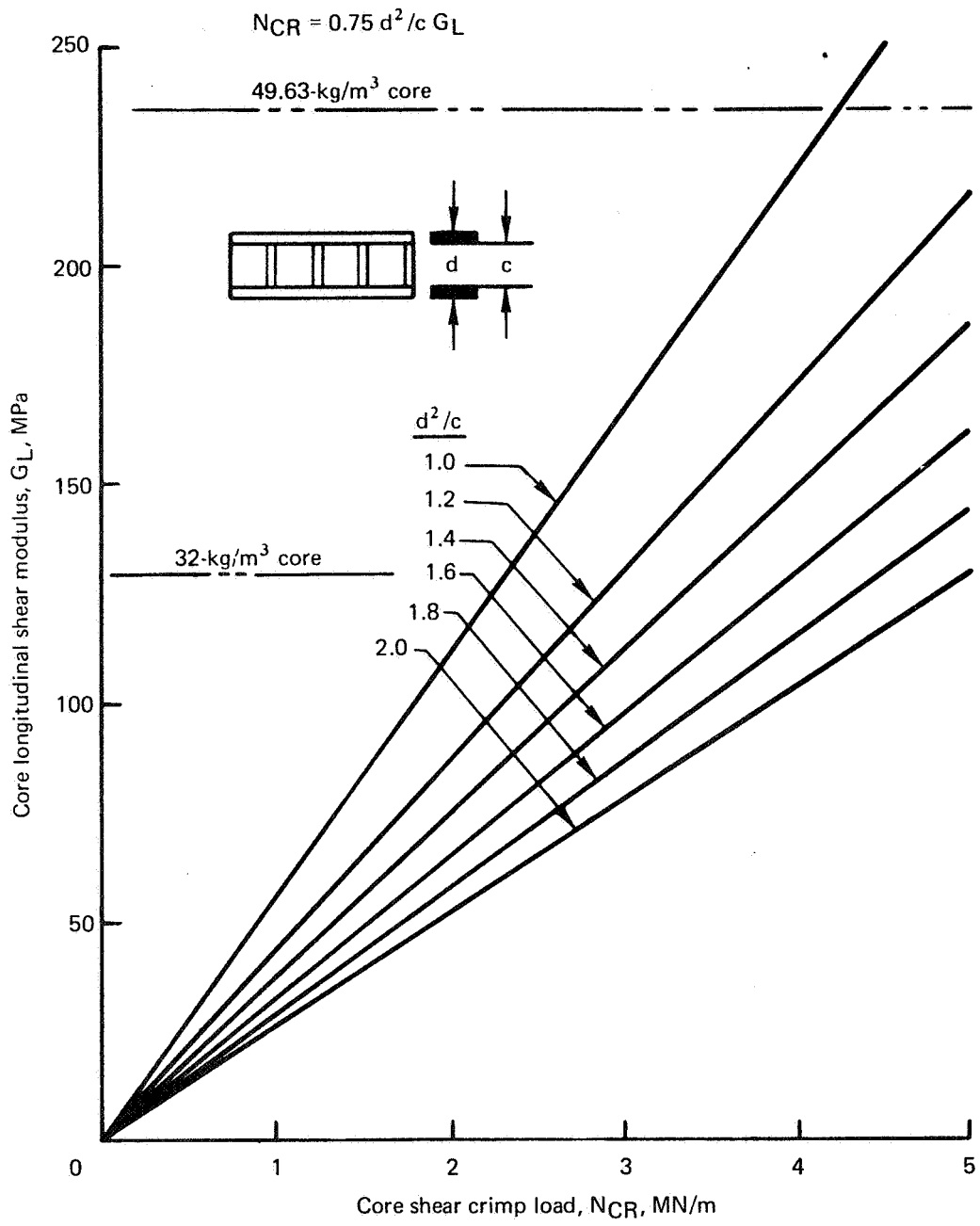

Figure 7.—Core Shear Crimping Allowable

The value of the parameter $G_L E_c$ for the minimum properties of a 49.63 kg/m^3 core is:

$$G_L E_c = 74\,519 \text{ TPa}^2$$

It is clear, then, that face wrinkling modes of failure should not be encountered for the maximum allowed elastic stress levels and the minimum density core of 49.63 kg/m^3 .

The load introduction fitting selected for mass and cost evaluations is shown in the following sketch.

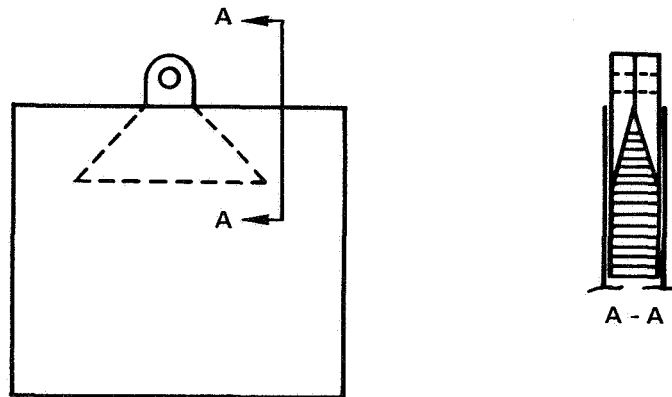

The fitting material was aluminum for the aluminum panels and the fitting material was titanium for the graphite panels. The skin-to-fitting adhesive bond area was chosen so that the adhesive shear stress did not exceed 13.79 MPa . The reaction edges were mass estimated for full depth potting 38.1 mm into the panel with a material having a density of 881 kg/m^3 . This may not be the optimum fitting for all panels, but one concept had to be selected and applied uniformly to maintain one-to-one comparisons between the panels. The load introduction fitting was analyzed for bearing stresses as well as the adhesive bond shear stresses.

Numerous other joint configurations could have application for specific panel arrangements. The popular step-lapped joint shown here is an example.



This type of joint is efficient but is moderately difficult to achieve because of the close-tolerance machining and hand-layup requirements. It would probably cost more than the one selected. Another loaded-edge concept could be a denser core on the panel edge with fastener padup material added to the surface. The greater density core is required for fastener pullup load. The density of the edge core is dictated by the load requirement and, ultimately, by the fastener size requirement. The edge skin padup layers would probably be $\pm 45^\circ$ for maximum bearing capability, as shown in the following sketch.

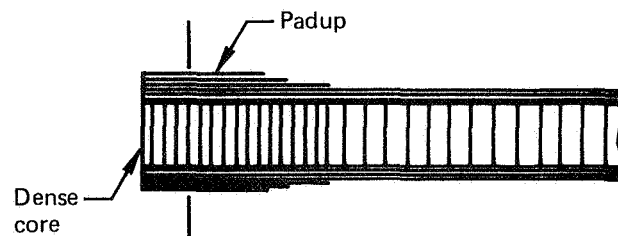

The skin gage at the concentrated load introduction fitting need not be the full gage indicated by the skin gage distribution topography. The fitting itself can be considered as contributing to the skin gage. A reasonable procedure would be to maintain the skin gage topography required up to the fitting periphery. From there, the skin gage would remain constant over the fitting area and the fitting provides the necessary local padup for the concentrated load.

Early in the program, several failure theories were used in various computer programs. It was found that sufficient difference in analytical results required a standardized selection. The ATLAS program is based on the Hill-Von Mises distortion energy failure criterion, which seems to be the most popular failure criterion for metals. Since this study assumed quasi-isotropic properties for the graphite-epoxy material, it was considered appropriate to apply the Hill-Von Mises failure theory to both the aluminum and graphite panels. Two exceptions to this condition were fiber-failure oriented compression cases. The facing material allowables used in this study were restricted to elastic maximums to compile the maximum amount of analytical data without exhaustive excursions into inelastic analysis, which was not within the scope of the program.

Examples of the plate stresses and gages produced by the ATLAS program are shown in appendix B. One example is for aluminum and one is for graphite. Two small example panels were fabricated using the ATLAS data and are discussed in appendix C.

SANDWICH PANEL DATA

The analytical data accumulated in this study are summarized in the data banks of tables 1, 2, and 3. The panels indicated as master skin gage distribution panels are further refined and presented as topographical skin gage distribution figures. There is one master panel for each aspect ratio of 0.25, 0.50 and 1.0. Both shear and compression cases are considered for each aspect ratio. Both aluminum and graphite skin materials are represented in the topographical skin gage distribution figures. The remaining data bank cases are used to verify the concepts and techniques resulting from this study and to provide additional cases of potential interest. For example, other cases in the data bank are used for demonstrating the following:

1. Master panel concept
2. Buckling load to core depth ratio
3. Buckling load to panel size ratio
4. Skin mass to panel size ratio
5. Skin mass to load ratio
6. Effect of fixed reaction edges on skin mass
7. Effects of panel ζ or edge padup on skin mass
8. Minimum-gage penalties
9. Varying graphite ply orientation, not quasi-isotropic
10. Ratio of buckling to skin modulus

The loading code for the various cases in the data bank is indicated in figure 8. Panels are uniformly loaded in compression or with a parabolic shear load in the shear cases and have simply supported edges unless otherwise noted.

COMPRESSION PANEL DATA

A comparison of two compression cases on aluminum-faced panels demonstrates the master panel skin gage distribution concept. These two cases have the same aspect ratio of 0.50, the same loading of 350.2 kN/m, and the same minimum-gage restriction of 0.406 mm total; but they have different sizes, one being 2.54 m square for a half-width panel and the other being 1.27 m square for a half-width panel. Figure 9 shows the skin gage distribution and total skin masses for these two panels. Note that the skin gages are essentially identical and the skin masses vary by a ratio of 1 to 4, the same as the panel areas vary. The master panel skin gage distribution concept is that panels of a given aspect ratio and the same unit loading will have the same skin gage distribution from a scalable standpoint. A similar comparison can be made

Table 1.—Optimized Panel Skin Masses—Aluminum

Skin Matl	Panel size		Full panel AR	Reaction	Avg load, kN/m	Half-panel skin mass, kg	Total min. gage, mm	Remarks
	Height, meters	Half-width, meters						
7075-T6	1.27	2.54	0.25	Comp.	175.1	14.56	0	Master skin gage
7075-T6	2.54	2.54	0.50	Comp.	175.1	15.10	0	Master skin gage
7075-T6	5.08	2.54	1.0	Comp.	175.1	22.72	0	Master skin gage
7075-T6	2.54	2.54	0.50	Comp.	350.2	30.21	0	---
7075-T6	2.54	2.54	0.50	Comp.	700.4	15.20	0	---
7075-T6	1.27	1.27	0.50	Comp.	350.2	7.89	0.41	---
7075-T6	2.54	2.54	0.50	Comp.	175.1	16.28	0.41	---
7075-T6	2.54	2.54	0.50	Comp.	350.2	30.98	0.41	---
7075-T6	2.54	2.54	0.50	Comp.	700.4	61.51	0.41	---
7075-T6	2.54	2.54	0.50	Comp.	175.1	15.15	0	Opt. Al post down ϕ of panel
7075-T6	2.54	2.54	0.50	Comp.	175.1	15.33	0	Opt. Al edges
7075-T6	2.54	5.08	0.25	Shear	175.1	65.91	0	Master skin gage
7075-T6	2.54	2.54	0.50	Shear	175.1	24.09	0	Master skin gage
7075-T6	5.08	2.54	1.0	Shear	175.1	45.36	0	Master skin gage
7075-T6	2.54	1.27	1.0	Shear	175.1	11.34	0	---
7075-T6	1.27	1.27	0.50	Shear	175.1	6.03	0	---

Table 2.—Optimized Panel Skin Masses—Graphite^a

Skin matl	Panel size		Full panel AR	Reaction	Avg load, kN/m	Half-panel skin mass, kg	Total min. gage, mm	Remarks
	Height, meters	Half-width, meters						
ISG	1.27	2.54	0.25	Comp.	175.1	7.08	0	Master skin gage
ISG	2.54	2.54	0.50	Comp.	175.1	7.21	0	Master skin gage
ISG	5.08	2.54	1.0	Comp.	175.1	10.34	0	Master skin gage
ISG	2.54	2.54	0.50	Comp.	350.2	14.38	0	---
ISG	2.54	2.54	0.50	Comp.	700.4	28.80	0	---
ISG	2.54	2.54	0.50	Comp.	175.1	11.34	1.02	---
ISG	1.27	2.54	0.25	Comp.	175.1	8.16	1.02	---
ISG	5.08	2.54	1.0	Comp.	175.1	21.41	1.02	---
ISG	2.54	2.54	0.50	Comp.	350.2	16.47	1.02	---
ISG	2.54	2.54	0.50	Comp.	700.4	30.25	1.02	---
ISG	5.08	2.54	1.0	Comp.	175.1	9.93	0	Fixed-reaction edge, point load
ISG	2.54	2.54	1.0	Comp.	175.1	4.99	0	Fixed-reaction edge, point load
ISG	2.54	2.54	0.50	Comp.	175.1	7.76	0	Opt. Ti post down panel Q
ISG	2.54	2.54	0.50	Comp.	175.1	7.76	0	Opt. Ti edges
ISG	2.54	2.54	0.50	Comp.	175.1	39.73	0.51	Opt. ply orientation ^b
ISG	2.54	2.54	0.50	Comp.	175.1	43.09	0.51	Hybrid 0° = HSG, ±45° = ISG, 90° = HMG
ISG	2.54	5.08	0.25	Shear	175.1	31.52	0	Master skin gage
ISG	2.54	2.54	0.50	Shear	175.1	12.47	0	Master skin gage
ISG	2.54	1.27	1.0	Shear	175.1	6.01	0	Master skin gage
ISG	5.08	2.54	1.0	Shear	175.1	10.52	0	Fixed-reaction edge, point load

^a Except as noted, matrix properties used were for quasi-isotropic 0°, ±45°, 90°.

^b The number of individual plies was restricted only to a minimum of 1 ply each of 0°, ±45°, and 90°. The layup was not restricted to equal numbers of plies. Fiber properties were used.

Table 3.—STAGS-B Buckling Loads

Core Thickness = 25.4 mm (Except as Noted)

Skin matl	Panel size		Full-panel AR	Reaction	Uniform skin gage, mm	Buckle load, kN/m	Remarks
	Height, meters	Half-width, meters					
AL 7075-T6	1.27	2.54	0.25	Comp.	1.02	74.60	Uniform reaction
AL 7075-T6	2.54	2.54	0.50	Comp.	1.02	39.40	Uniform reaction
AL 7075-T6	5.08	2.54	1.0	Comp.	1.02	29.60	Uniform reaction
AL 7075-T6	2.54	0.635	2.0	Comp.	1.02	498.89	Uniform reaction
AL 7075-T6	2.54	2.54	0.50	Comp.	1.02	9.81	Uniform reaction, core = 12.7 mm
AL 7075-T6	2.54	2.54	0.50	Comp.	1.02	157.61	Uniform reaction, core = 50.8 mm
AL 7075-T6	2.54	2.54	0.50	Comp.	1.02	30.12	Point reaction, point load
AL 7075-T6	2.54	2.54	0.50	Comp.	1.02	61.99	Uniform reaction, uniform load
AL 7075-T6	2.54	1.27	1.0	Comp.	1.02	117.86	Fixed-reaction edge, point load
AL 7076-T6	2.54	2.54	0.50	Comp.	1.02	35.20	Fixed-reaction edge, point load
AL 7075-T6	1.27	2.54	0.25	Comp.	1.02	56.92	Point reaction, point load
AL 7075-T6	2.54	5.08	0.25	Shear	1.02	32.05	Parabolic shear reaction
AL 7075-T6	2.54	2.54	0.50	Shear	1.02	38.53	Parabolic shear reaction
AL 7075-T6	2.54	1.27	1.0	Shear	1.02	49.56	Parabolic shear reaction
AL 7075-T6	2.54	1.27	1.0	Shear	1.02	85.56	Fixed-reaction edge, point load
ISG	2.54	2.54	0.50	Comp.	—	8.93	Actual sculptured gage (6 gages)
ISG	1.27	1.27	0.50	Comp.	0.51	48.42	Uniform reaction
ISG	2.54	2.54	0.50	Comp.	0.51	12.10	Uniform reaction
ISG	2.54	2.54	0.50	Comp.	—	10.20	Actual sculptured gage (81 gages)
ISG	2.54	2.54	0.50	Shear	0.51	14.64	Parabolic shear reaction
ISG	1.27	1.27	0.50	Shear	0.51	58.58	Parabolic shear reaction
ISG	2.54	2.54	0.50	Shear	—	18.88	Actual sculptured gage (81 gages)

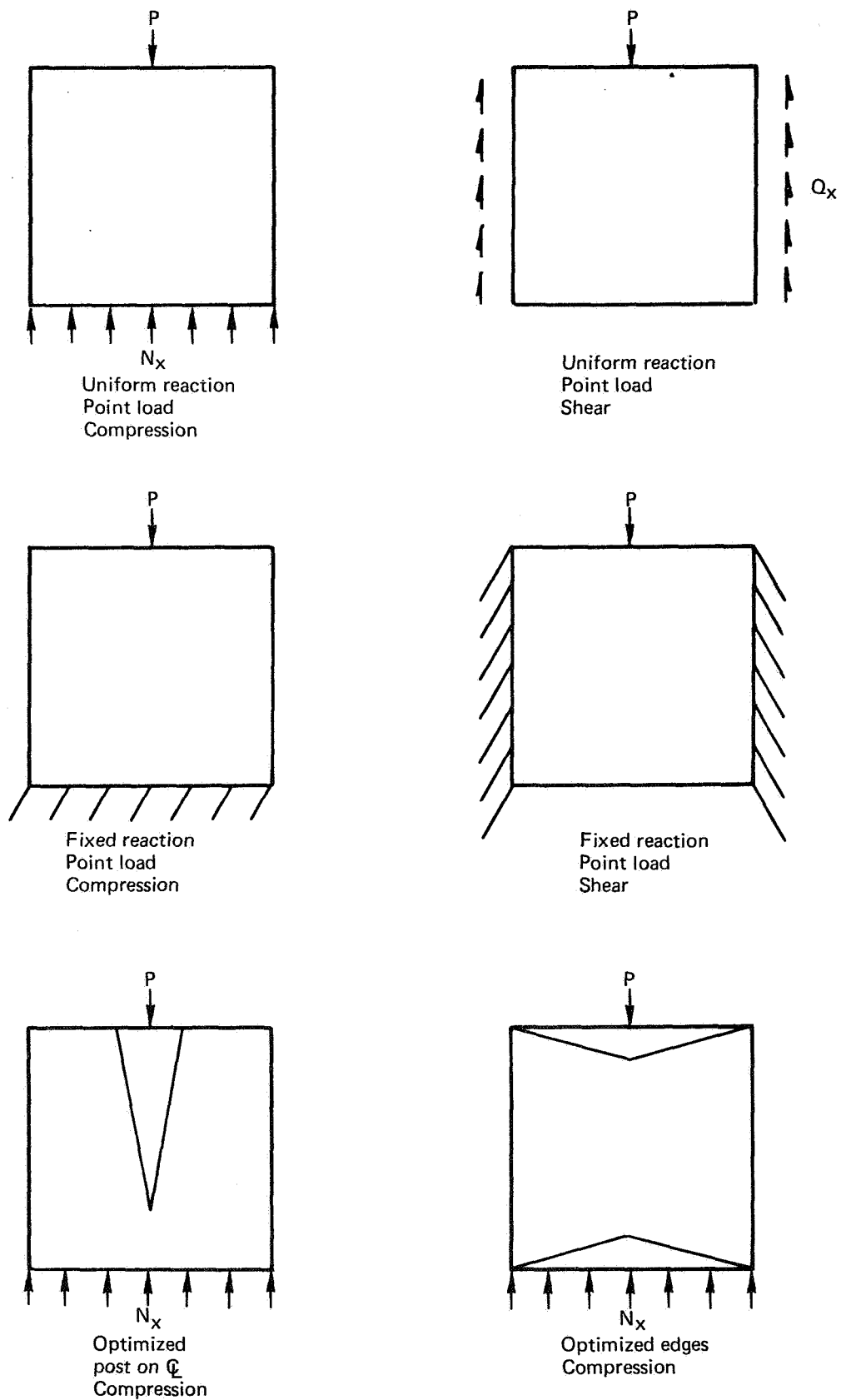

Figure 8.—Data Bank Loading Code Schematic

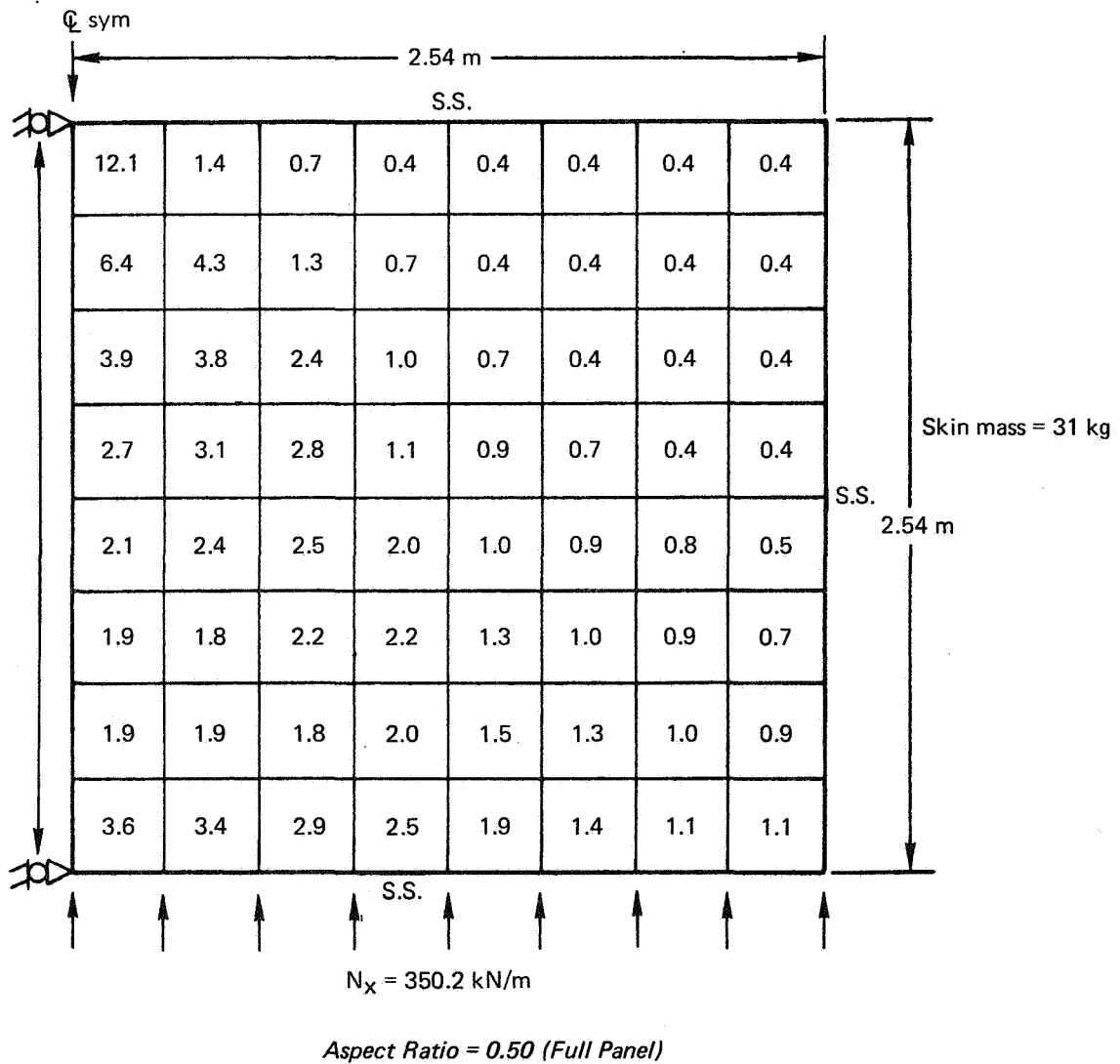
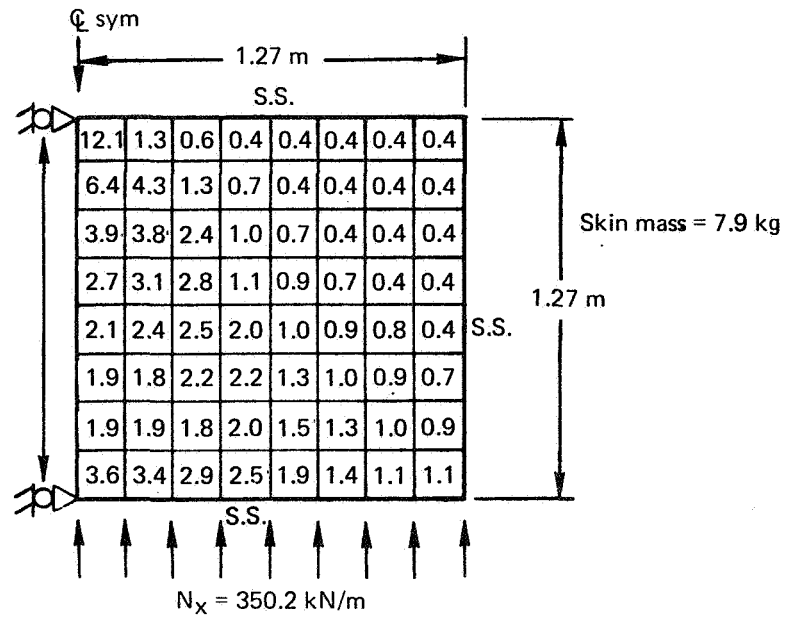

Figure 9.—Skin Gage Comparison of Different Size Compression Panels

for the shear reaction cases. It should also be pointed out that the skin material will have no effect on this relative distribution as long as elastic, isotropic properties are used. The actual skin gages will be simply the ratio of the allowable elastic stress to the master panel allowable stress times the master panel skin gages. The Poisson ratio of other materials must be similar to that used in the master panel; consequently, master panels were established for both aluminum and graphite skins.

Several of the compression panel skin weights may be compared to show that the skin weight is directly proportional to the panel area for a given loading and panel aspect ratio. This follows, since the skin gages have already been shown to be equal. Similarly, data examination shows that the skin weight is directly proportional to the load intensity; doubling load intensity doubles skin weight. This is a direct result of the fully stressed plate elements.

Other edge conditions and load conditions were included as additional data of potential interest in the data bank, although an analysis of these cases was not intended to be within the scope of this study.

Some compression panels were sized by adding material as a post down the panel Q_L or adding edge material as beam flanges. The skin weights of these panels are very nearly the same as the baseline panels having no posts or edge members because the computer was unable to maintain a uniform load and change the area of the previous baseline panels. The computer did provide area to the post or edges, but removed it from the skin area so the total local areas were essentially the same as the baseline topography. An unloaded post down a compression panel Q_L could result in a lighter core mass because of enhancement of panel buckling load. This feature was not rigorously investigated in this study because the uniform load criteria would not be realized. These geometries would fall into the category of skin-stiffened sandwich panels.

It can be shown that it is possible to reduce a panel mass by increasing the skin gage and reducing the core thickness accordingly. For example, if a given panel skin gage is doubled, the buckling load also doubles since the stress of the panel skins is one-half that of the master panel. The core thickness may now be reduced by a factor of $\sqrt{2}$. In some panel designs, it may be possible that the reduced core mass more than offsets the increased skin mass. It may be further shown that it is possible to achieve a reduced panel mass if the ratio of skin weight to core weight is less than 0.5. In other words, a least mass panel should have a skin mass greater than one-half the core mass. This derivation logic follows:

Let panel mass be composed of $A + B + C + D$, where

A = skin mass

B = core mass

C = adhesive mass

D = fitting mass

Increment the skin mass by a factor K . This reduces core thickness required for buckling by \sqrt{K} . The new panel mass is now,

$$K A + \frac{B}{\sqrt{K}} + C + D$$

The question now is, when is this new mass less than the original mass? Or when is

$$K A + \frac{B}{\sqrt{K}} + C + D < A + B + C + D$$

assuming fitting mass and adhesive mass remain constant.

A solution is when

$$\frac{A}{B} < \frac{1}{K + \sqrt{K}}$$

Choose a value for K that is close to unity, such as 1.01. This will show when even a small increase in skin mass will result in reduced panel mass.

The substitution results in the relation,

$$\frac{A}{B} < 0.5$$

The conclusion, then, is that total panel mass may be reduced by skin mass increases if the existing fully stressed skin mass is less than one-half the core mass. It also indicates that panel skin mass should be at least one-third of the combined skin and core mass. The mass saving will probably be greater due to probable fitting-mass saving for the less thick core. A plot of this relation and the relative panel masses is shown in figure 10.

Nonuniform skin gage increases could be more efficient for increasing the buckling load and reducing the core mass but would result in nonuniform loads which were not considered in this study.

Table 2 also indicates two other cases of interest—the optimized-ply orientation and the hybrid. These two computer analysis cases did not restrict the graphite skin layup to equal numbers of 0° , $\pm 45^\circ$, and 90° plies as in the other cases, but did require at least one layer of each. The hybrid case restricted the 0° plies to the properties of high-strength graphite, the $\pm 45^\circ$ plies to intermediate-strength graphite, and the 90° plies to high-modulus graphite. In both cases, fiber properties were used rather than matrix properties. The failure criteria, therefore, were governed by fiber strength. The applied load in both cases was 1751 kN/m versus the baseline load of 175.1 kN/m. If the indicated baseline skin weights are increased by a factor of 10 to equate the load levels, the optimized-ply orientation weight is 39.73 kg and the hybrid weight is 43.09 kg. These masses compare to the baseline, no-minimum-gage mass of 72.1 kg, which is a significant mass saving over the quasi-isotropic baseline layup. It

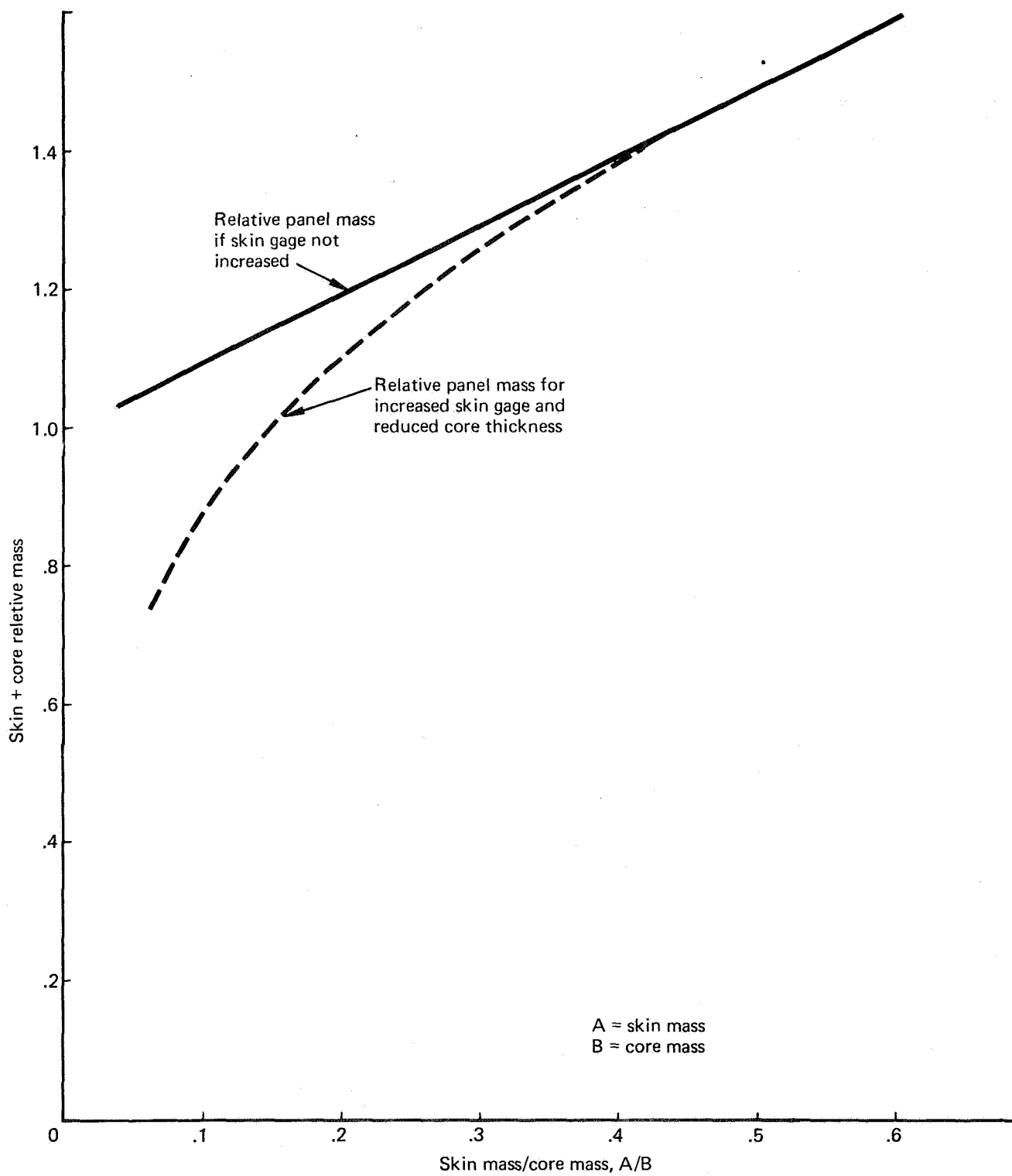

Figure 10. — Relative Total Panel Mass Versus Skin-to-Core Mass Ratio

should be pointed out that this achievement is unobtainable in lower load ranges since the 1751-kN/m loading resulted in panel skins of only one ply of a given orientation. Reducing the load level would result in fractional plies which are unachievable. It is significant, however, that theoretical mass savings up to 55% are possible with a tailored-ply orientation versus a quasi-isotropic orientation. It is also noted that some of this saving may be due to the fiber-failure strength criteria used in the tailored-ply orientations.

As far as the optimized-ply orientation versus hybrid comparison is concerned, the slightly greater mass of the hybrid case is believed due to the influence of the reduced material strength properties of the high-modulus graphite. The computer analysis allows no benefit for the high-modulus material for a fully stressed design. The high-modulus material offers some benefit only in the buckling analysis. The preliminary conclusion is that the higher cost materials in the hybrid are not justified in this design. Figure 11 shows the optimized layout indicated by the computer analysis.

Sufficient minimum-gage mass penalty data are included in the data bank so that assessment is possible both in aluminum- and graphite-skinned panels. The minimum gages selected for study were 1.02 mm for graphite skins and 0.406 mm for aluminum skins. These are the total minimum plate thicknesses input to the sizing program and they represent the sum of both sandwich faces.

The plots of figures 12 and 13 can be constructed, by knowing that skin mass is proportional to load intensity for a no-minimum-gage panel and that zero load results in zero theoretical skin mass, and by knowing, further, what the minimum gage skin mass is for a given panel size. From these plots of specific data bank results, the generalized design plots of figures 14 and 15 may be generated. The demonstrated fact that skin masses are proportional to panel area for equal aspect ratio panels allows the mass penalties to be generalized in terms of percentage of total skin mass for the various aspect ratio panels. Mass penalty estimates may be made for minimum gages other than those selected, but accurate data would require computer analysis.

SHEAR PANEL DATA

More emphasis was placed on the compression panels than on the shear-reacted panels. Most of the same comparisons may be made on the shear panels as on the compression panels. Master panel skin gage distribution topographical figures are derived for the same cases as the compression panels. Three aspect ratios and two skin materials were studied. The ratio technique of extrapolating the analytical data on compression panels is also applicable to the shear panel data bank. The shear panels were not fully assessed for minimum-gage mass penalties since they were of secondary concern to this study. The shear panel skin mass is observed to be consistently greater than the comparable compression panel skin mass required to transmit a given load over a given distance.

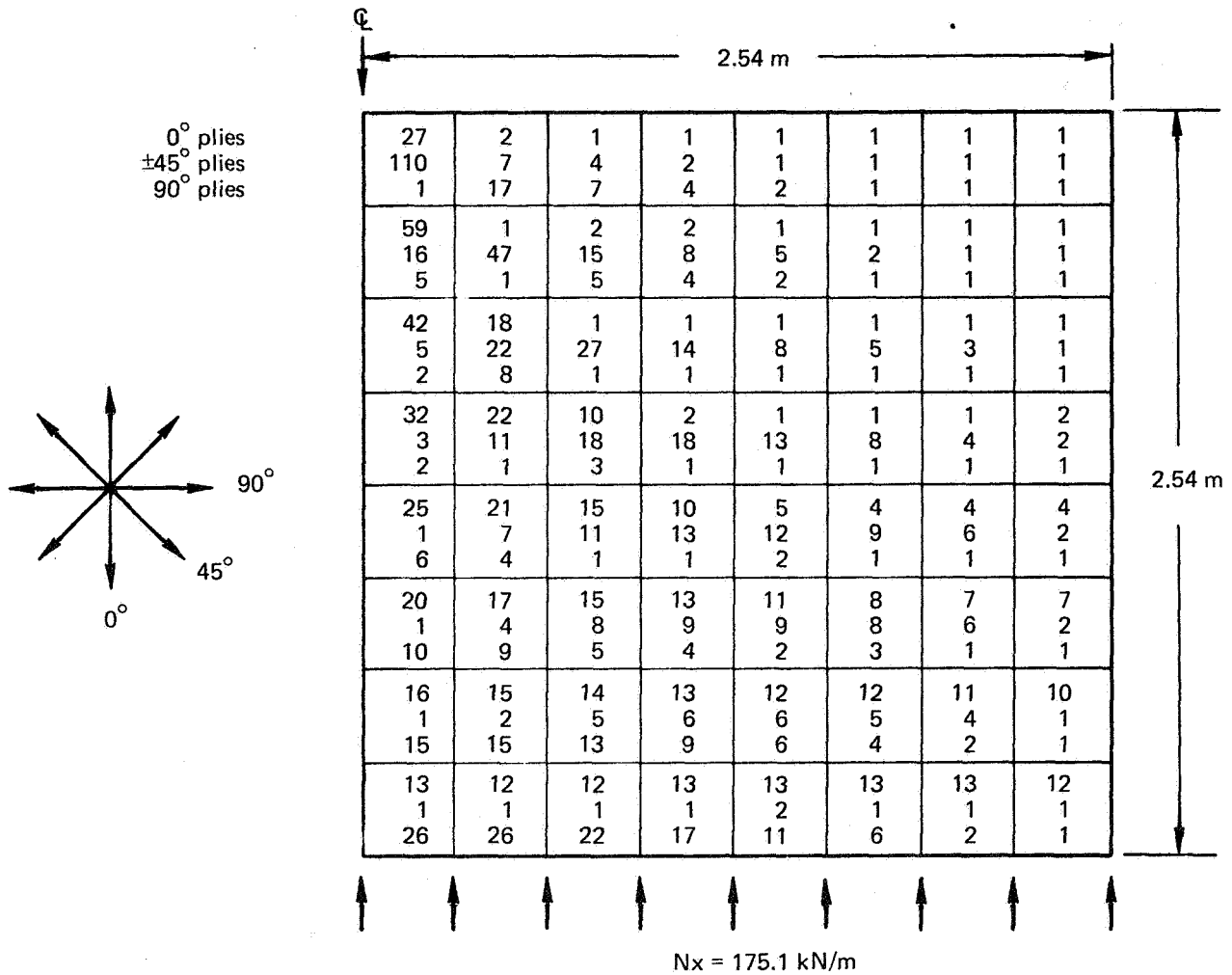

Skin mass = 39.73 kg
 (Compared to comparable mass of 72.1 kg
 for a $0^\circ, \pm 45^\circ, 90^\circ$ quasi-isotropic layup)

Figure 11.—Ply Layout for a Panel Having Optimized Fiber Orientation

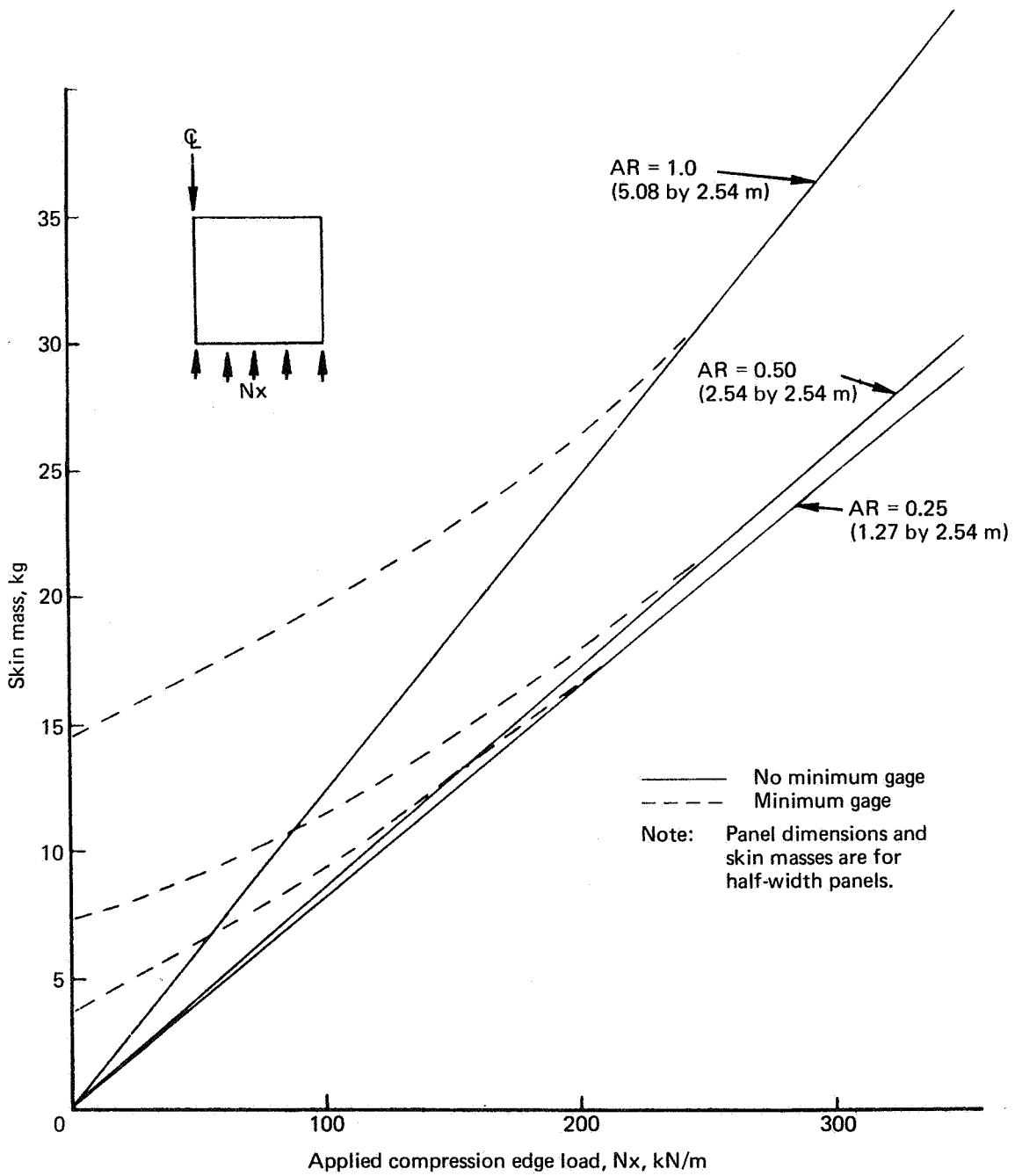

Figure 12.—Skin Mass Penalty for Aluminum-Faced Compression Panels Having Total-Facing Minimum Gage of 0.406 mm

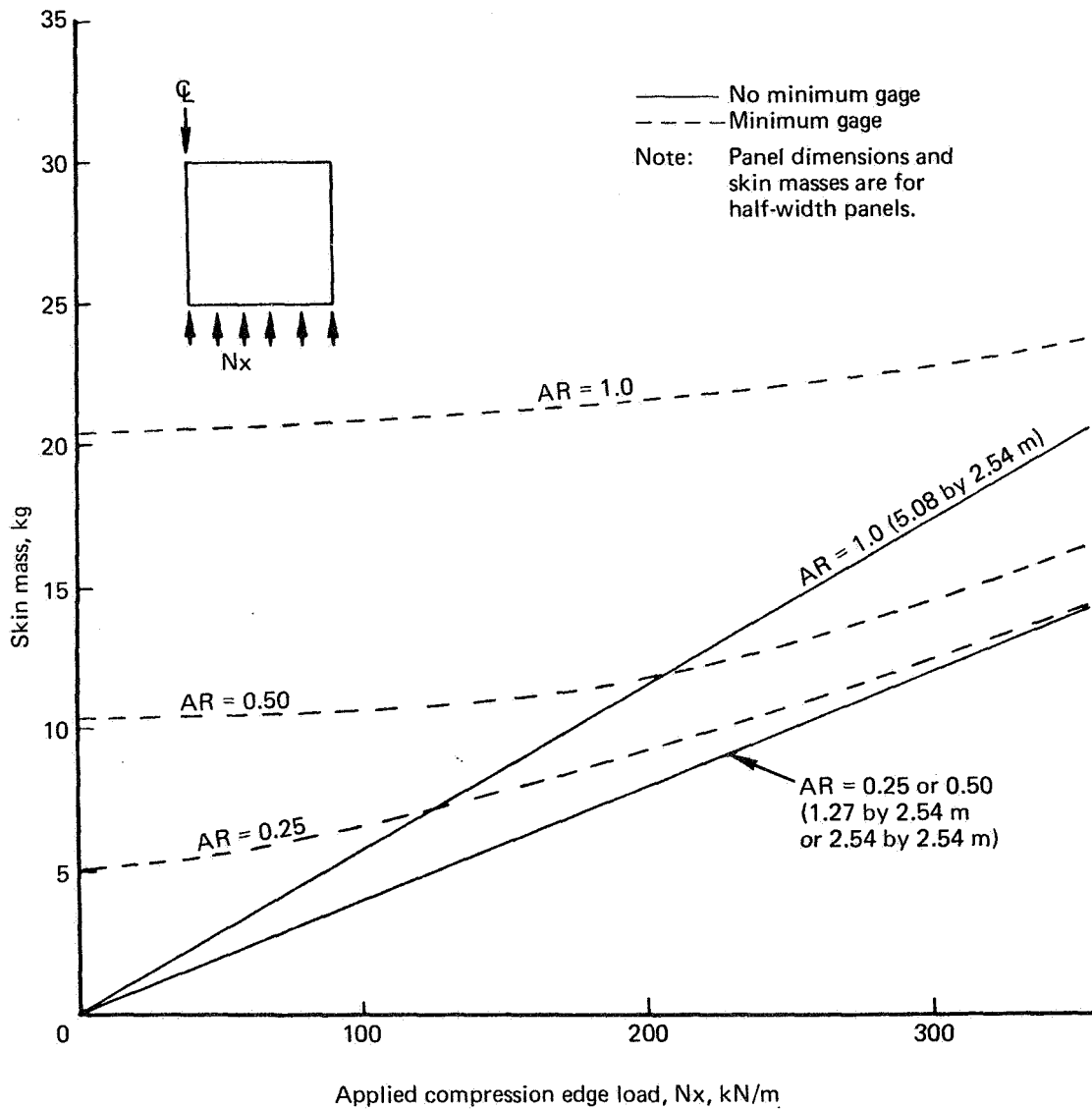

Figure 13.—Skin Mass Penalty for Graphite-Faced Compression Panels Having Total Facing Minimum Gage of 1.02 mm

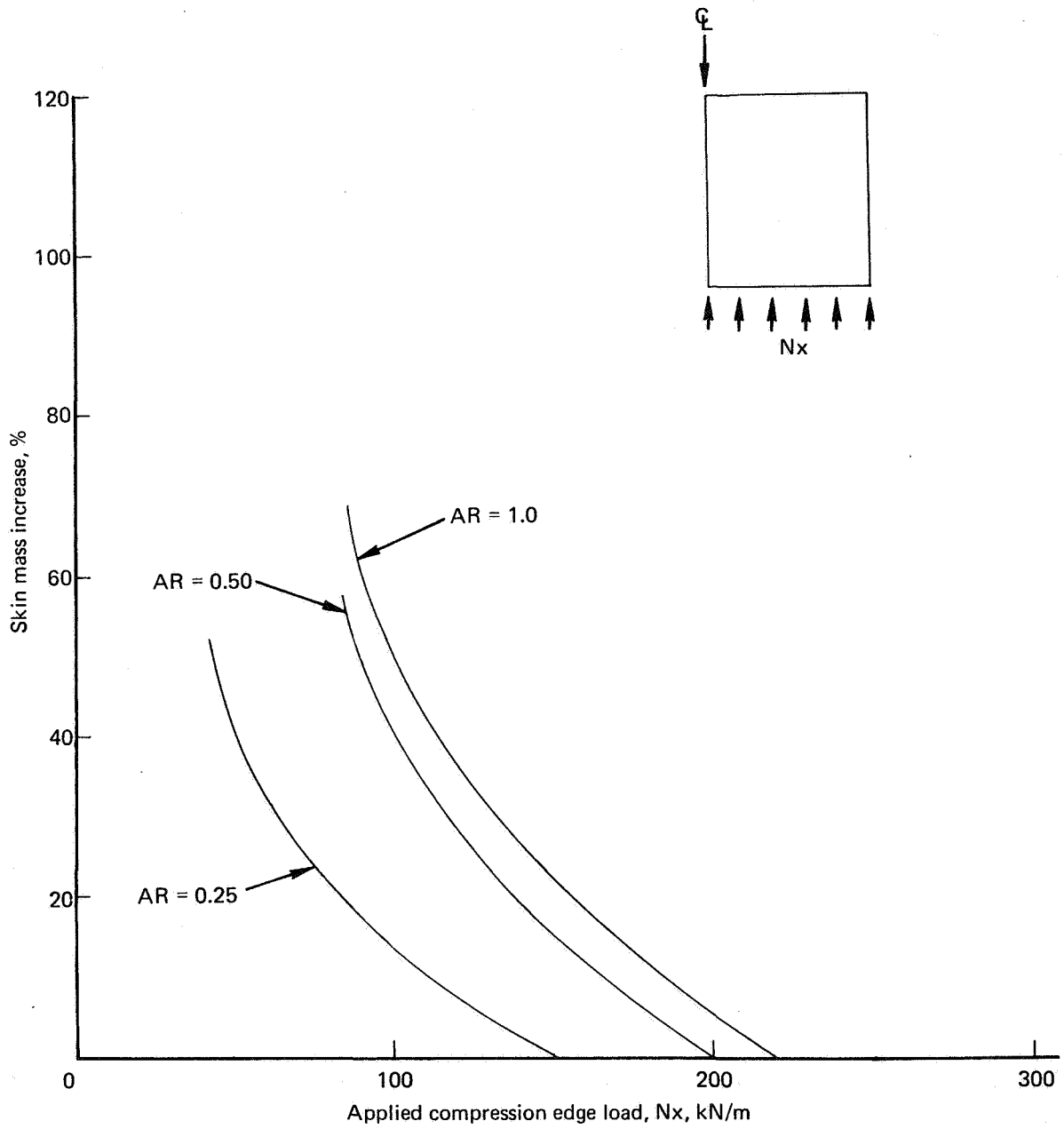

Figure 14. — Skin Mass Increase Required for Aluminum-Faced Compression Panels Having Total Facing Minimum Gage of 0.406 mm

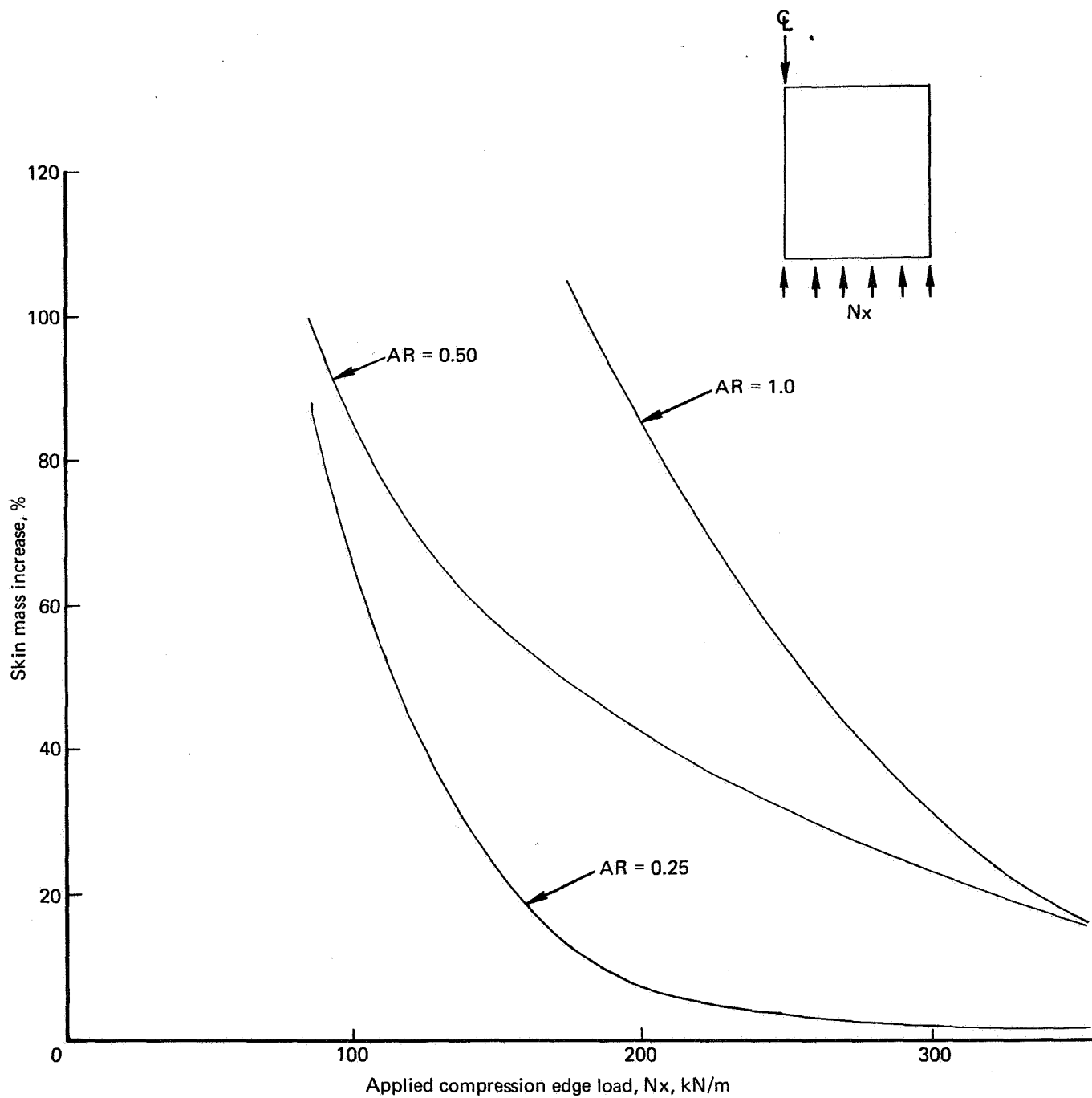

Figure 15. — Skin Mass Increase Required for Graphite-Faced Compression Panels Having Total Facing Minimum Gage of 1.02 mm

COST DATA

The cost data accumulated are presented in both tabular and graphical form. The variables studied were panel aspect ratio and load intensity. The cost study began with an estimate of fabrication man-hours, the predominant cost item. The estimating experience for the graphite-skinned sandwich panels was supported by the joint NASA/Boeing spoiler program, contract NAS1-11668. This program involved the construction of over 100 graphite-skinned sandwich spoilers for the Boeing 737 aircraft. Cost-tracking the fabrication of these spoilers was one aspect of this program, so a substantial cost base existed. Similarly, extensive cost experience on aluminum sandwich panels was available at Boeing. The Boeing production estimators considered recurring and nonrecurring costs. Basic factory labor was found by estimating from production planning. The other recurring costs are experience factors applied to the various items. An example of one panel fabrication cost breakdown is shown in appendix D. Cost estimates were made for a 1-unit production and a 50-unit production.

Both sculptured and constant-gage skins were costed, but the sculptured skins are the ones of primary interest to this study. The differences are shown in table 4.

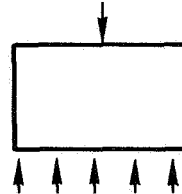

Table 4.—Compression Panel Cost in Fabrication Man-Hours

Skin matl	Units	Full panel size, meters		
		0.635 by 2.54	1.27 by 2.54	2.54 by 2.54
Sculptured Graphite	1	2 167	2 198	2 437
	50	10 105	11 375	14 288
Aluminum	1	1 667	1 691	2 178
	50	7 802	8 783	11 032
Constant Graphite	1	1 755	1 777	2 000
	50	9 242	10 404	13 068
Aluminum	1	1 350	1 370	1 780
	50	6 937	8 033	10 090

The graphite material cost is a significant factor in the cost study. It may be as little as 7% of the fabrication cost for a lightly loaded panel of smaller size with no minimum-gage constraints, or as much as 31% of the cost of a larger, lightly loaded panel having minimum-gage constraints placed on it. This cost can be affected by calendar time since graphite material is typically experiencing price reductions as usage increases. The chart of figure 16 indicates the anticipated cost/year prediction for graphite material. This projection may be applied to the data bank and cost studies to predict any combination of panel size, load intensity, and calendar year. The comparisons in this study are based on current cost data.

Other than the material cost in graphite panels, the major cost item is the recurring factory labor of process assembly, which accounts for approximately 60% of the fabrication man-hours.

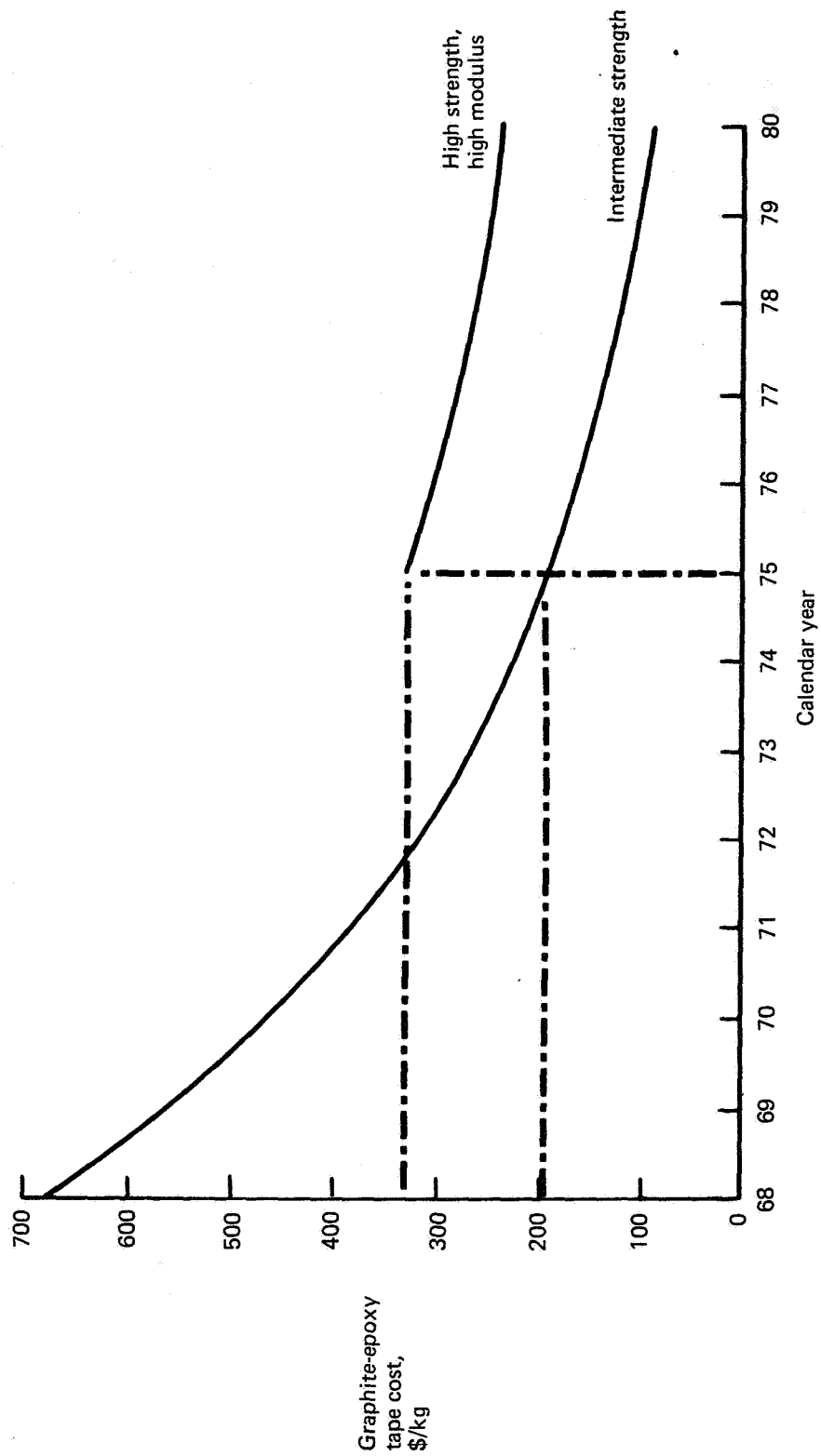

Figure 16.—Graphite-Epoxy Cost Projection

MASS AND COST COMPARISON

A detailed cost and mass breakdown was conducted for three aspect ratio panels with three compression load intensities for each. Preliminary design approaches were used. The panel sizes chosen were considered to be in the range of maximum interest. Material costs were found to be completely insignificant to fabrication costs, except for the graphite material cost. The delta material costs between aluminum and graphite were absorbed completely in estimating the graphite material cost.

The graphite skin material was estimated at current costs of \$187/kg plus an additional 15% increment allowed for excess and trim. The fabrication man-hour cost data were normalized at a value of \$25/man-hour to establish actual cost values. This detailed cost and mass breakdown was based on a production quantity of 50 units.

The mass breakdown also required some ground rules. The concentrated load fitting was estimated with the configuration previously discussed. Aluminum fitting material was used for the aluminum-skinned panels and titanium for the graphite-skinned panels.

The core mass was estimated by thickness sizing with ratio techniques from the STAGS-B buckling data bank, using a density of 49.63 kg/m³. The skin masses were taken from the compression panel data bank and ratioed for load and panel size as required. The adhesive mass was estimated at 0.586 kg/m², which is a typical sandwich adhesive mass.

The mass and cost data for three panel aspect ratios, for both aluminum- and graphite-skinned panels, and for three compression load levels are summarized in tables 5, 6, and 7. A single load case for shear-reacted load is analyzed for mass in table 8. These tables allow several comparisons to be made.

The fitting-mass percentages of panel mass are taken from the compression panel mass and cost summaries of tables 5, 6, and 7 and plotted in generalized form in figures 17 and 18. These figures may be used to provide a preliminary design estimate to the fitting mass for the panel. The procedure is first to sum the skin mass, the core mass, and the adhesive mass. This mass is increased by the factor $N/(1 - N)$, where N is the indicated fitting-mass factor taken from the appropriate figure 17 or 18. Refinement of this estimate requires a detailed fitting design.

The mass of aluminum- and graphite-faced panels is graphically presented in figure 19 for panels with no minimum-gage constraints and figure 20, with minimum-gage constraints. The graphite-skinned panels are lighter than aluminum for all load levels if no minimum gages are imposed but are not competitive with aluminum at low load levels with the established minimum gages.

A comparison of the masses of shear-reacted panel loads and compression-reacted loads is shown in figure 21 with no minimum-gage constraints and figure 22 with minimum-gage constraints. A single load level is used for the comparison and panel aspect ratio is varied. The graphical comparison shows that compression-reacted panels are of lesser mass than shear-reacted panels. Also demonstrated is that the shorter, low aspect ratio panels are of lesser mass for reacting the load than are the deeper, higher aspect ratio panels.

Table 5.—Compression Panel Mass and Cost Data Summary for Load of 222.4 kN

Mass, kg	0.635 m		1.27 m		2.54 m	
	No min. gage	Min. gage	No min. gage	Min. gage	No min. gage	Min. gage
AL	3.67	4.26	3.77	5.53	5.67	9.34
GR	1.77	3.18	1.81	4.99	2.59	10.43
Core ^a	1.72	1.72	6.12	6.12	16.32	16.32
GR	1.91	1.91	7.71	7.71	17.92	17.92
Fitting	2.13	2.13	3.54	3.54	4.63	4.63
GR	2.27	2.27	3.90	3.90	5.08	5.08
Adhesive	1.00	1.00	1.91	1.91	3.81	3.81
Total mass	8.53	9.12	15.38	17.10	30.39	34.06
GR	6.99	8.35	15.33	18.51	29.40	37.24
Mass saved with GR	1.54	0.77	0.05	-1.41	0.99	-3.18
Fabrication cost ^b	\$3 901	\$3 901	\$ 4 392	\$4 392	\$5 516	\$5 516
GR	\$5 053	\$5 053	\$ 5 688	\$5 688	\$7 144	\$7 144
GR material cost ^c	\$ 352	\$ 488	\$ 352	\$1 076	\$ 548	\$2 248
Total GR cost	\$5 405	\$5 501	\$ 6 040	\$6 764	\$7 692	\$9 392
\$ difference	\$1 504	\$1 600	\$ 1 648	\$2 372	\$2 176	\$3 876
\$ cost/kg saved	\$ 977	\$2 978	\$32 960	—	\$2 198	—

^a Core density was estimated at 49.63 kg/m³.

^b Fabrication hours were normalized at \$25/hr for costing purposes and are based on a 50-unit buy.

^c Graphite material was costed at \$187/kg plus 15% waste.

Table 6.—Compression Panel Mass and Cost Data Summary for Load of 444.8 kN

Mass, kg	0.635 m		1.27 m		2.54 m	
	No min. gage	Min. gage	No min. gage	Min. gage	No min. gage	Min. gage
AL	7.35	7.35	7.53	7.85	11.34	12.34
GR	3.54	4.08	3.63	5.72	5.17	10.70
Core ^a	1.72	1.72	6.12	6.12	16.28	16.28
AL	1.91	1.91	7.71	7.71	17.92	17.92
GR	2.36	2.36	3.76	3.76	4.81	4.81
Fitting	2.59	2.59	4.67	4.67	5.35	5.35
AL	1.00	1.00	1.91	1.91	3.81	3.81
GR	12.43	12.43	19.32	19.87	36.24	37.24
Total mass	9.03	9.57	17.92	20.00	32.25	37.78
AL	3.40	2.86	1.40	-0.13	3.99	-0.54
GR						
Mass saved with GR						
Fabrication cost ^b	\$3 901	\$3 901	\$4 392	\$4 392	\$5 516	\$5 516
AL	\$5 053	\$5 053	\$5 688	\$5 688	\$7 144	\$7 144
GR	\$ 762	\$ 880	\$ 782	\$ 1 232	\$ 1 114	\$ 2 306
GR material cost ^c	\$5 815	\$5 933	\$6 470	\$6 920	\$8 258	\$9 450
Total GR cost	\$1 914	\$2 032	\$2 078	\$2 528	\$2 742	\$3 934
\$ difference	\$ 563	\$ 710	\$ 1 484	—	\$ 687	—
\$ cost/kg saved						

^a Core density was estimated at 49.63 kg/m³.

^b Fabrication hours were normalized at \$25/hr for costing purposes and are based on a 50-unit buy.

^c Graphite material was costed at \$187/kg plus 15% waste.

Table 7.—Compression Panel Mass and Cost Data Summary for Load of 889.6 kN

	No min. gage	Min. gage	No min. gage	Min. gage	No min. gage	Min. gage
Mass, kg						
Skin						
AL	14.70	14.70	15.15	15.51	22.68	23.59
GR	7.10	7.26	7.26	8.16	10.34	11.79
Core ^a						
AL	1.72	1.72	6.12	6.12	16.28	16.28
GR	1.91	1.91	7.71	7.71	17.92	17.92
Fitting						
AL	2.86	2.86	4.26	4.26	5.31	5.31
GR	3.18	3.18	5.26	5.26	5.94	5.94
Adhesive						
AL	1.00	1.00	1.91	1.91	3.81	3.81
GR	20.28	20.28	27.44	27.80	48.08	48.99
Total mass						
AL	13.15	13.34	22.14	23.04	38.01	39.46
GR	7.13	6.94	5.30	4.76	10.07	9.53
Mass saved with GR						
Fabrication cost ^b						
AL	\$3 901	\$3 901	\$4 392	\$4 392	\$5 516	\$5 516
GR	\$5 053	\$5 053	\$5 688	\$5 688	\$7 144	\$7 144
GR material cost ^c	\$1 526	\$1 564	\$1 564	\$1 760	\$2 228	\$2 542
Total GR cost	\$6 579	\$6 617	\$7 252	\$7 448	\$9 372	\$9 686
\$ difference	\$2 678	\$2 716	\$2 860	\$3 056	\$3 856	\$4 170
\$ cost/kg saved	\$ 376	\$ 391	\$ 540	\$ 642	\$ 383	\$ 438

^a Core density was estimated at 49.63 kg/m³.

^b Fabrication hours were normalized at \$25/hr for costing purposes and are based on a 50-unit buy.

^c Graphite material was costed at \$187/kg plus 15% waste.

Minimum skin gage = 0.203 mm each face

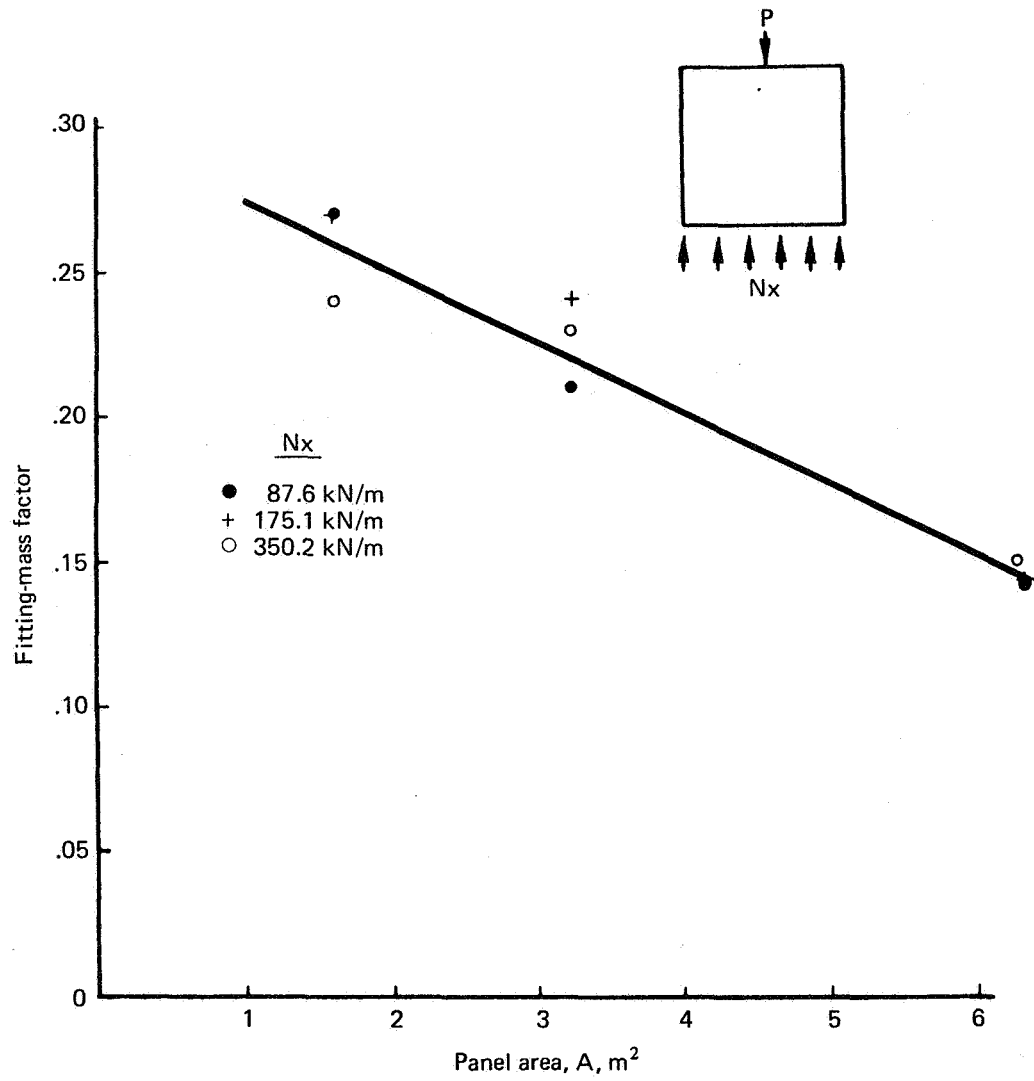

Figure 17.—Fitting-Mass Factor Versus Panel Area for Aluminum-Faced Compression Panels

Minimum skin gage = 0.51 mm each face

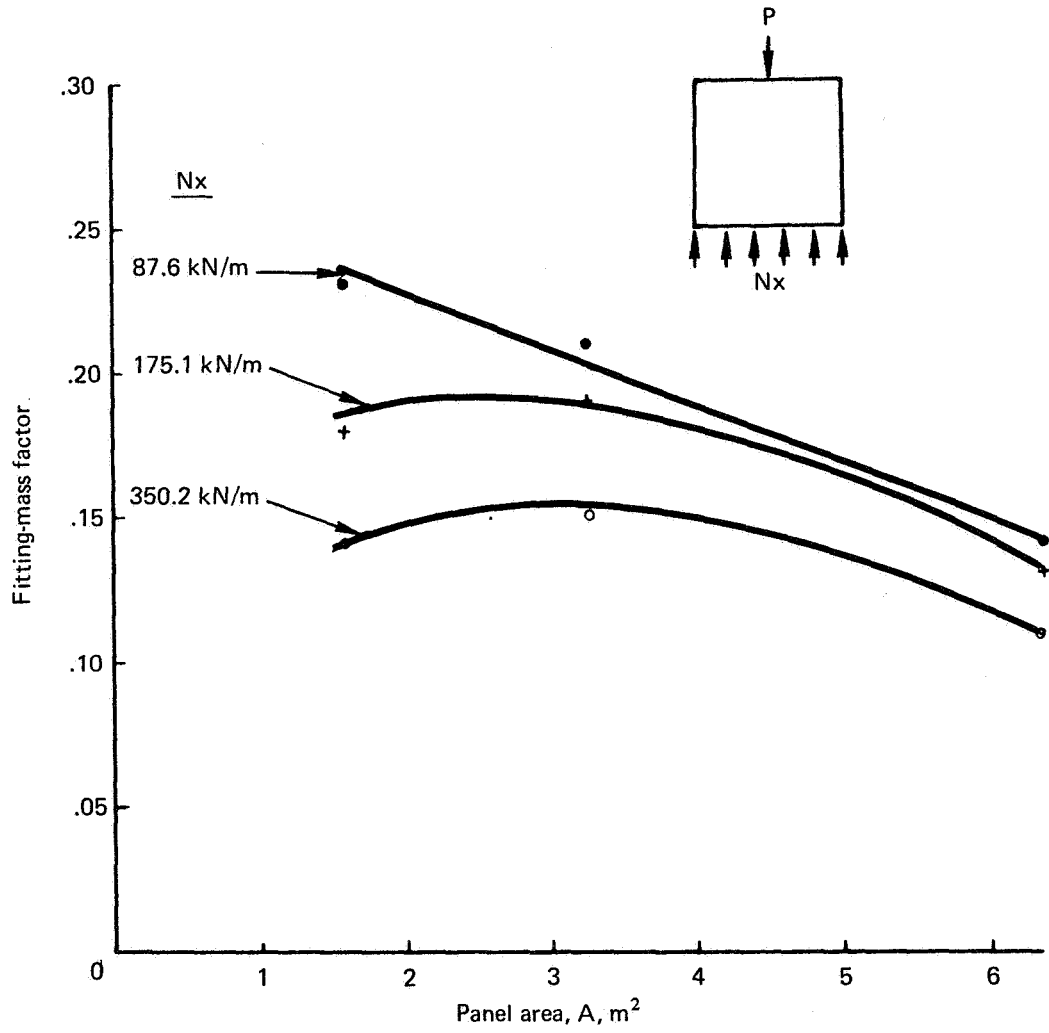

Figure 18.—Fitting-Mass Factor Versus Panel Area for Graphite-Faced Compression Panels

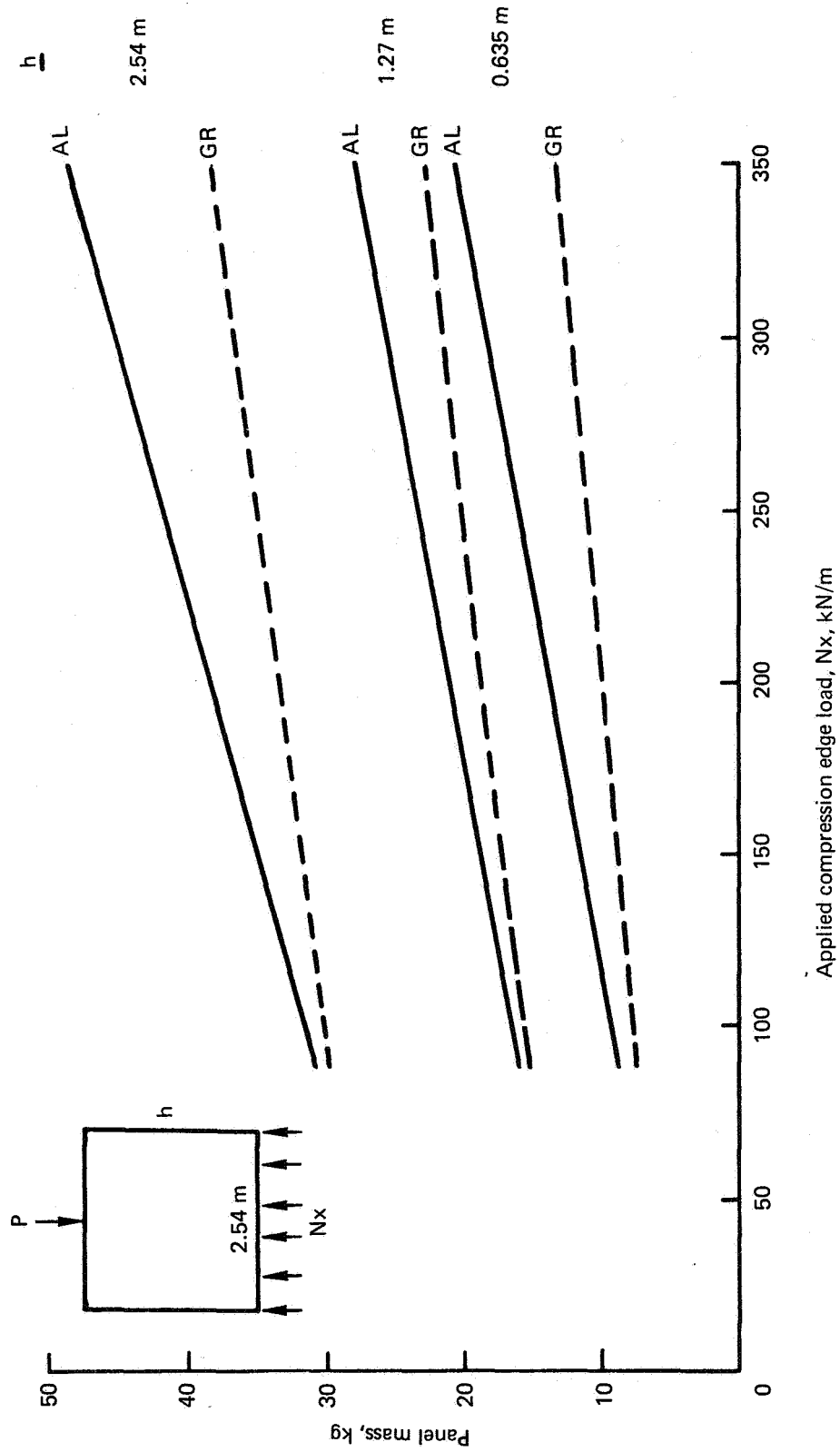

Figure 19.—Total Mass of Various Sized Panels with Aluminum and Graphite Skins—
No Minimum-Gage Constraints

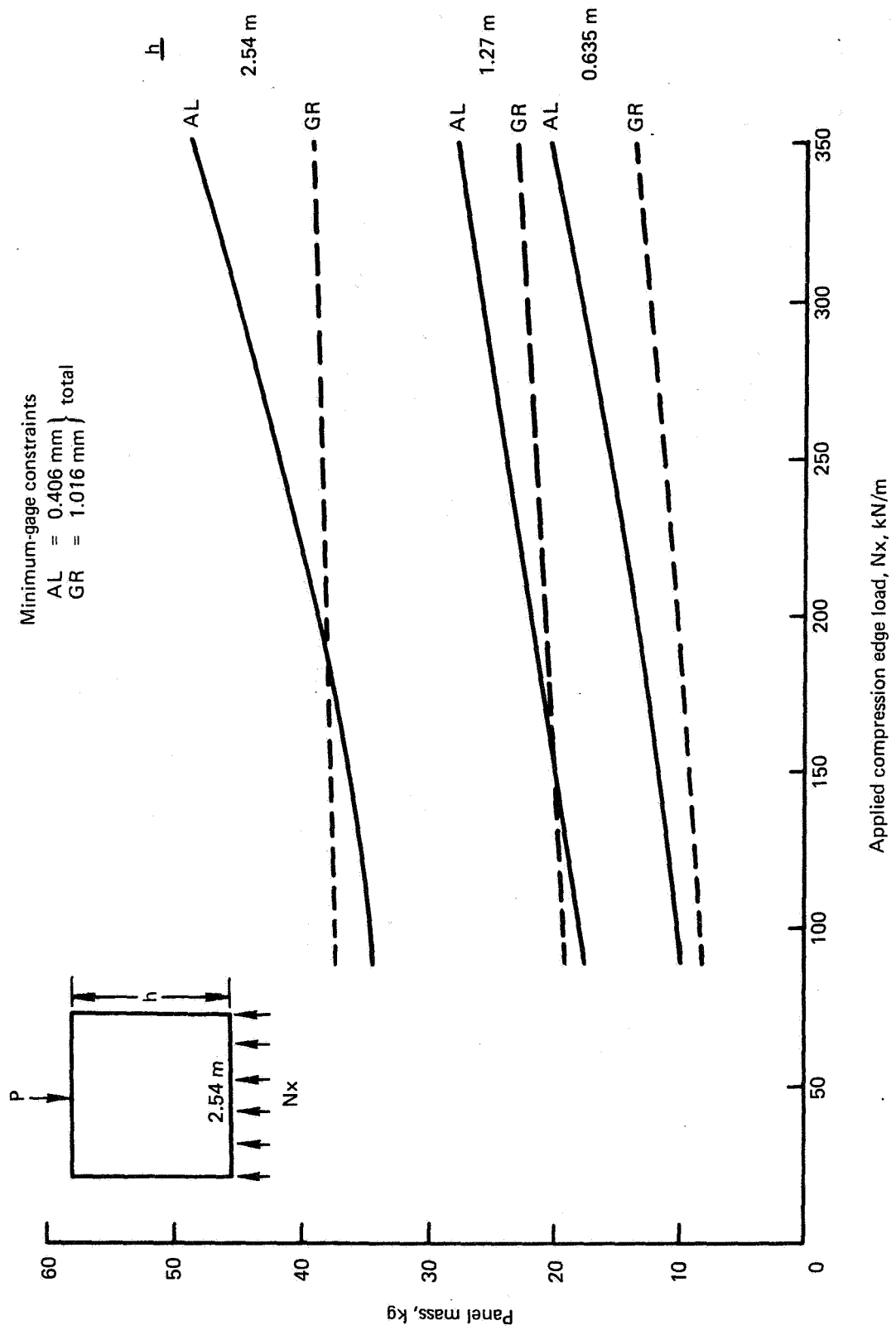

Figure 20.—Total Mass of Various Sized Panels With Aluminum and Graphite Skins—
 With Minimum-Gage Constraints

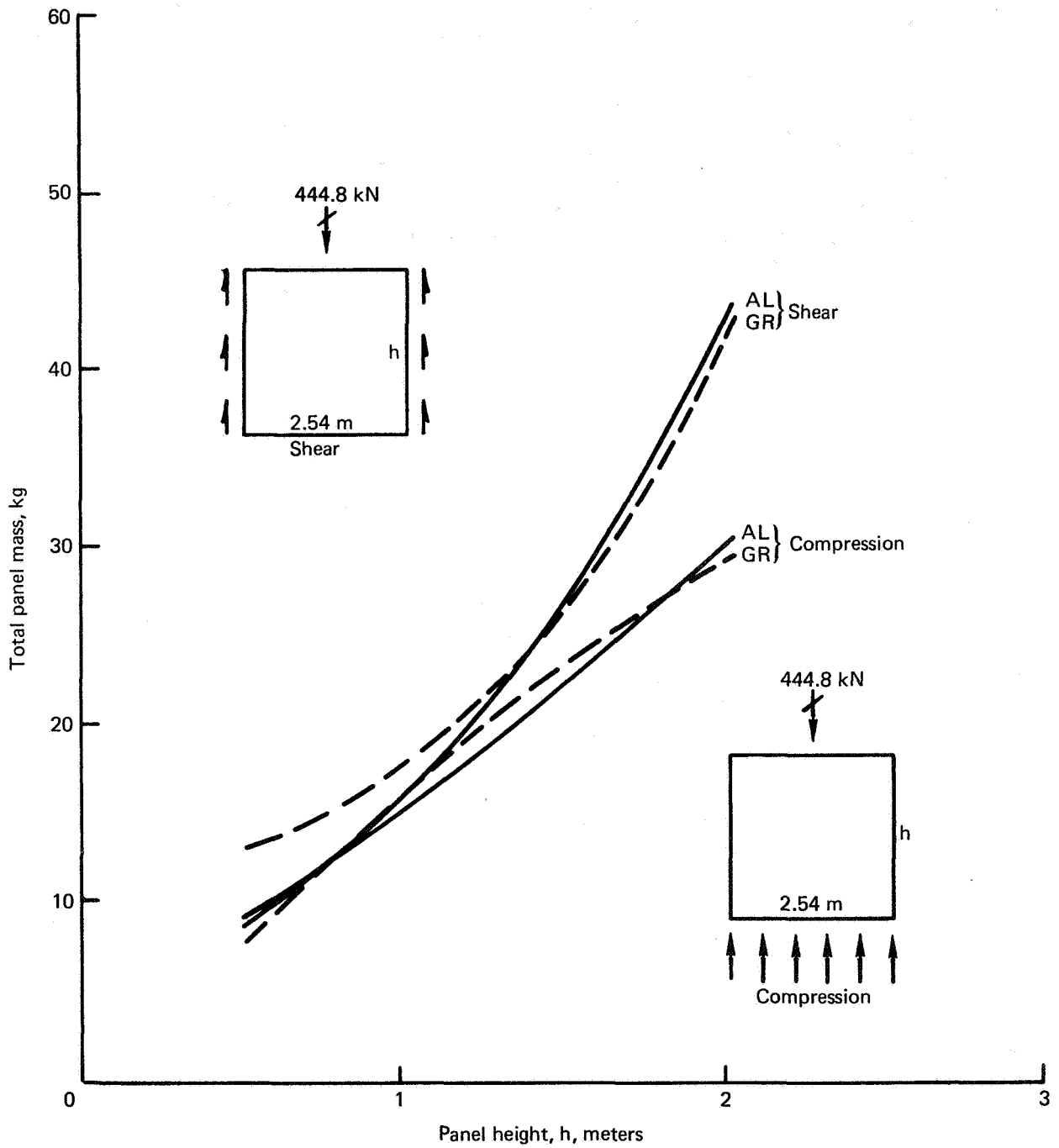

Figure 21.—Panel Mass Versus Panel Size—No Minimum-Gage Constraints

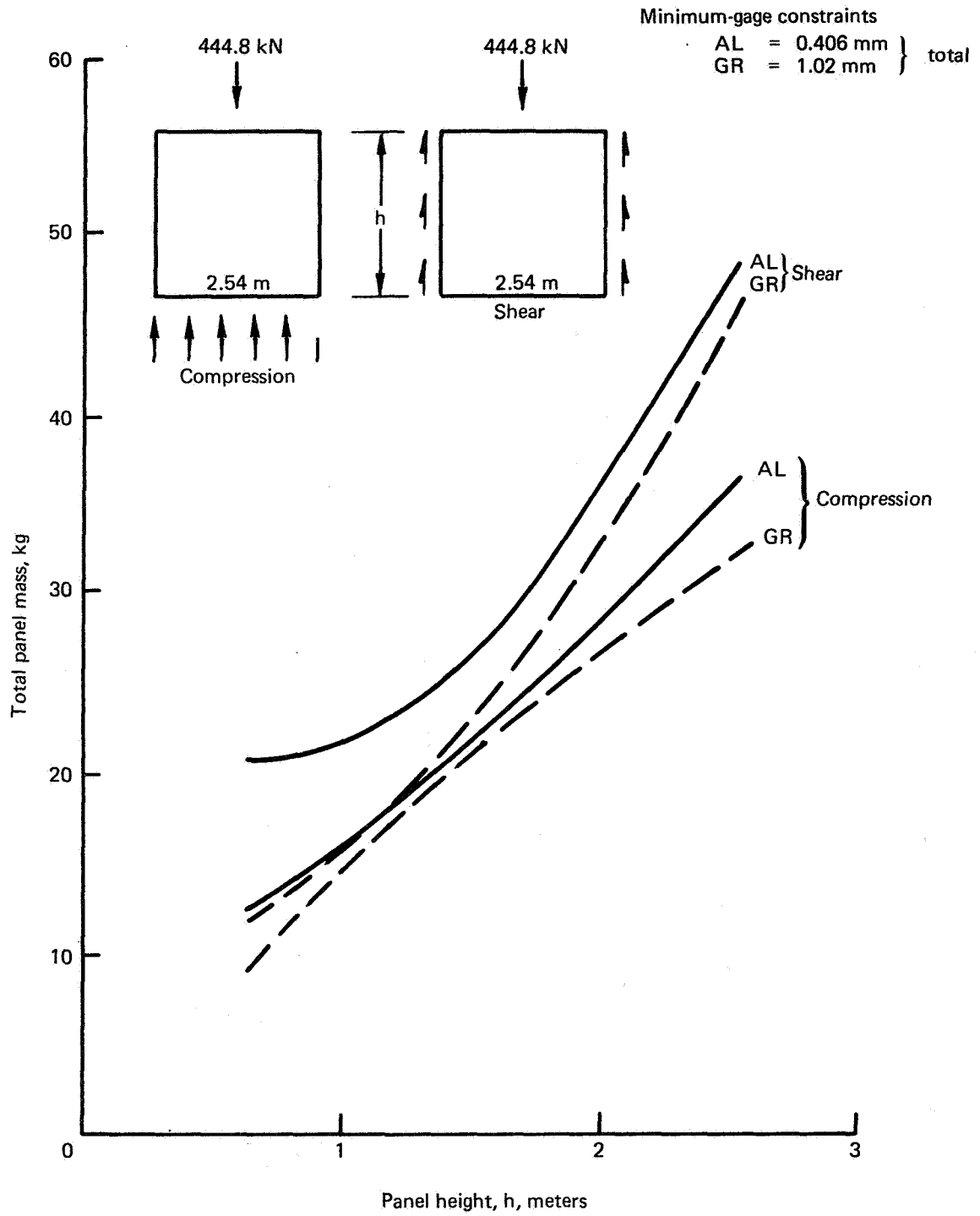

Figure 22.—Panel Mass Versus Panel Size—With Minimum-Gage Constraints

Table 8.—Shear Panel Mass Summary

Load = 222.4 kN
No minimum gage

Mass, kg			
Skin	AL	16.51	12.07
	GR	7.80	6.26
Core	AL	1.95	6.89
	GR	2.09	7.71
Fitting	AL	1.68	2.95
	GR	1.91	3.31
Adhesive		1.00	1.91
Total mass	AL	21.14	23.82
	GR	12.80	19.19
Mass saved with GR		8.34	4.63

An index of structural efficiency can be the load transferred per unit mass of structure. This index is compiled for three aspect ratio panels, three load levels, and both aluminum and graphite skin compression panels, and shown in figure 23 with no minimum-gage constraints and in figure 24 with minimum-gage constraints. In both cases, it is clear that the short, low aspect ratio panels are more efficient than the longer, higher aspect ratio panels.

The cost per unit mass of the three aspect ratio compression panels is compared for both aluminum and graphite skins in table 9, with three load levels considered.

The cost/kilogram of mass saved by using graphite skins rather than aluminum skins is shown in figure 25 with no minimum-gage constraints and in figure 26 with minimum-gage constraints. Graphite is not always mass competitive with aluminum for some combinations of load intensity and panel size because of the minimum-gage restrictions placed on the two materials.

Figure 27 shows the graphical comparison of cost per panel for a 50-unit quantity of aluminum- and graphite-faced panels. The cost of aluminum panels is essentially unaffected by load level because the additional aluminum required is insignificant in cost. The material cost of graphite does cause a distinguishable difference in panel cost for various load levels.

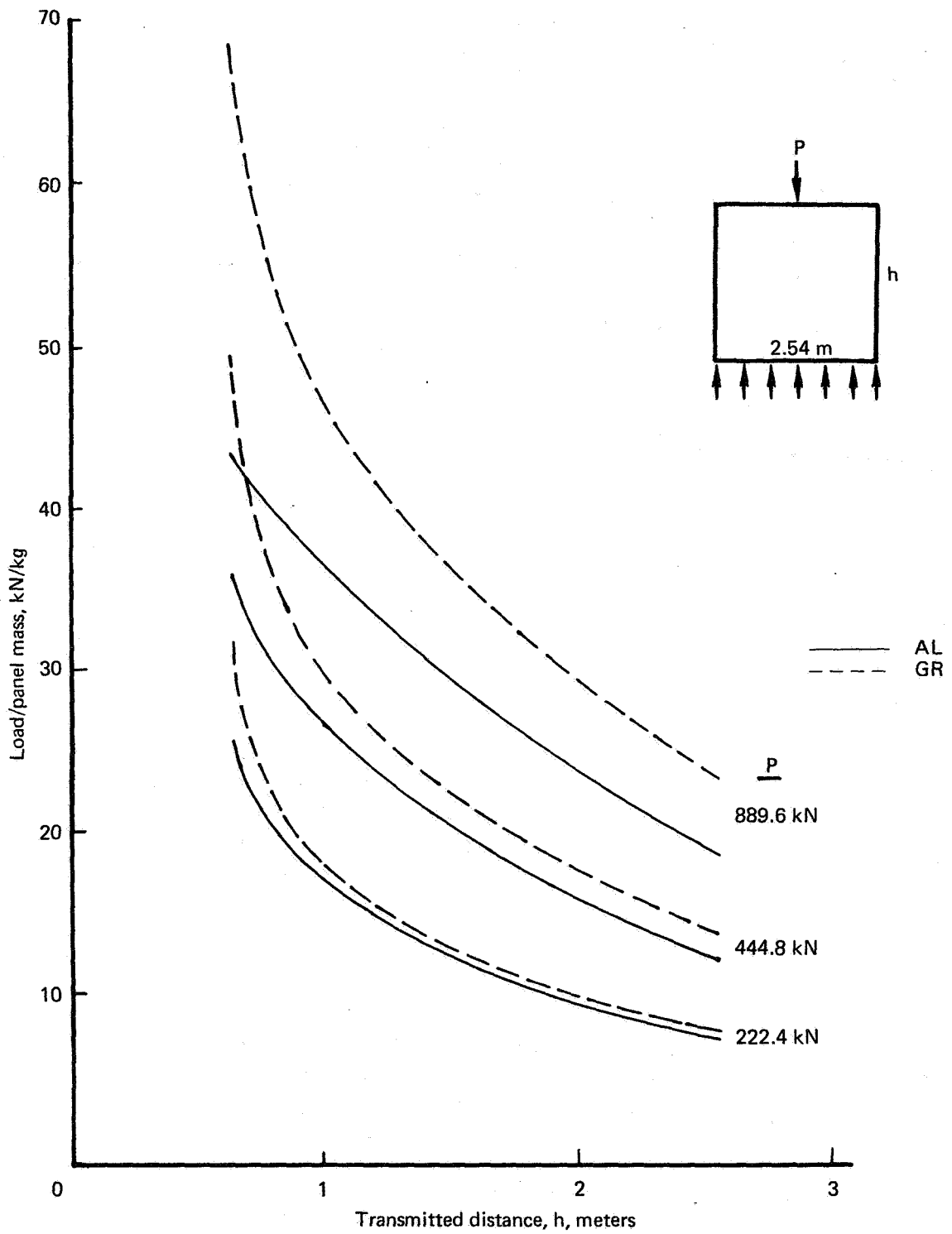

Figure 23.—Relative Efficiencies of Aluminum and Graphite Compression Panels—
No Minimum-Gage Constraints

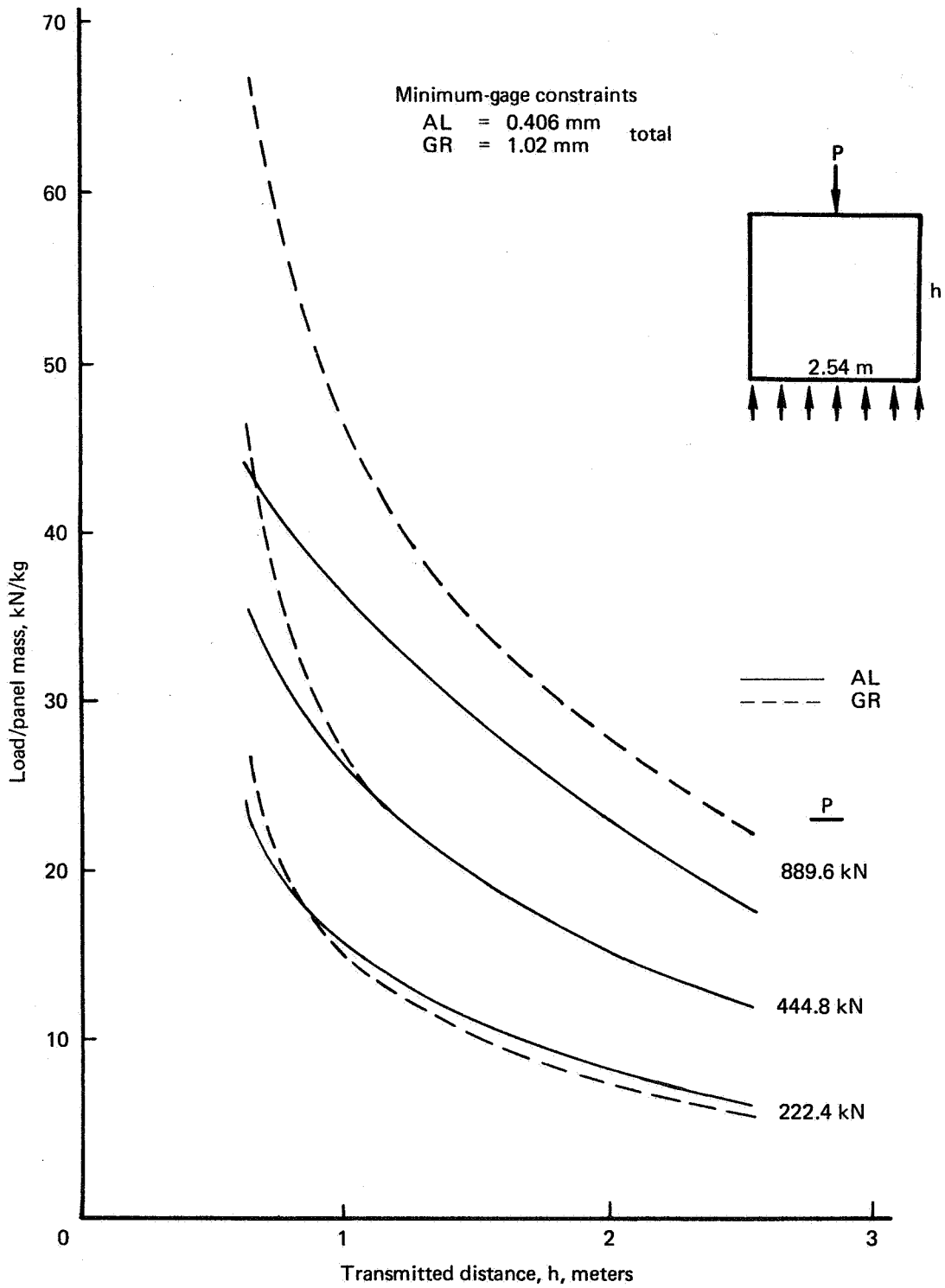

Figure 24.—Relative Efficiencies of Aluminum and Graphite Compression Panels—
 With Minimum-Gage Constraints

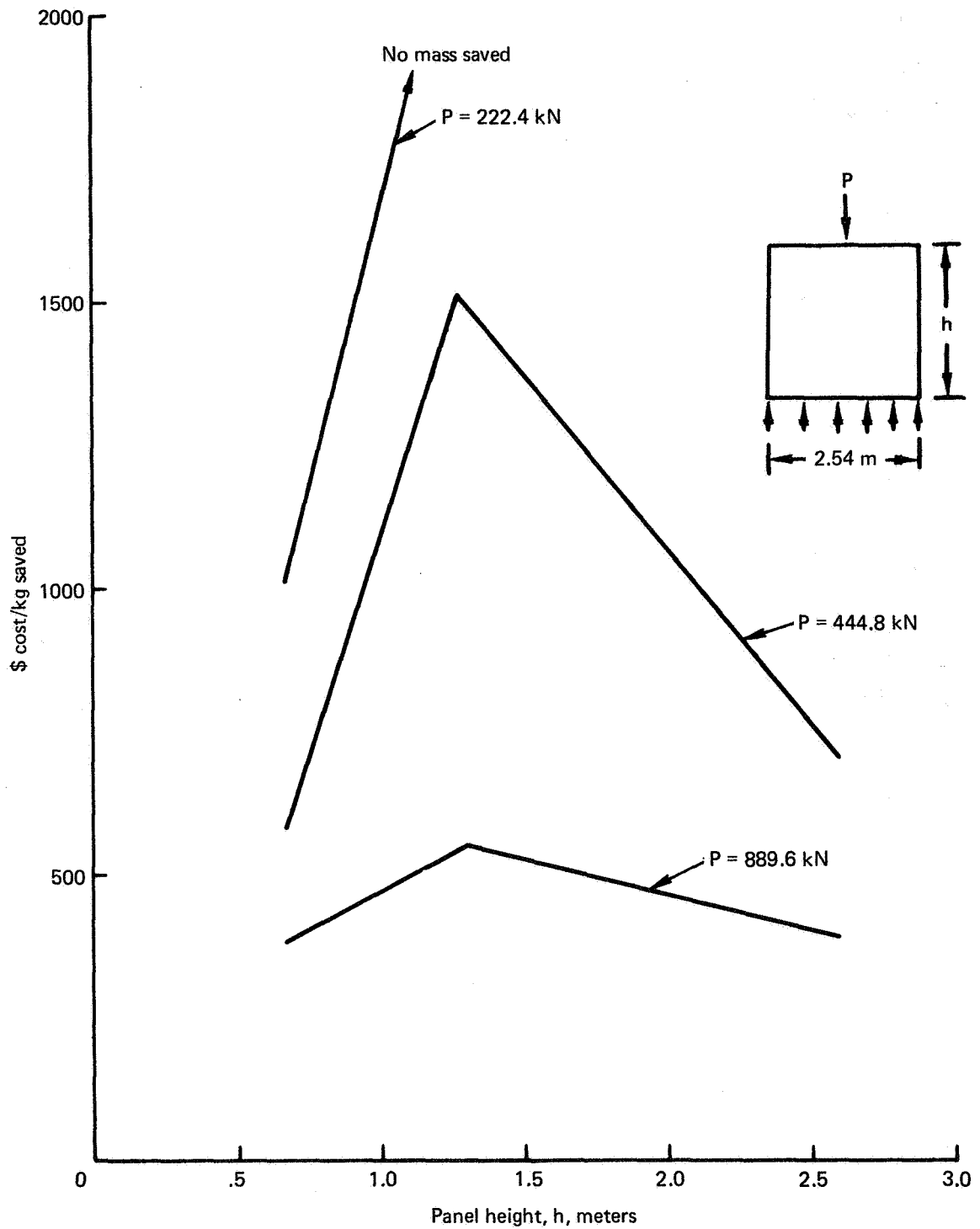

Figure 25.—Cost of Each Kilogram Saved by Use of Graphite Instead of Aluminum Skins on Compression Panels—No Minimum-Gage Constraints

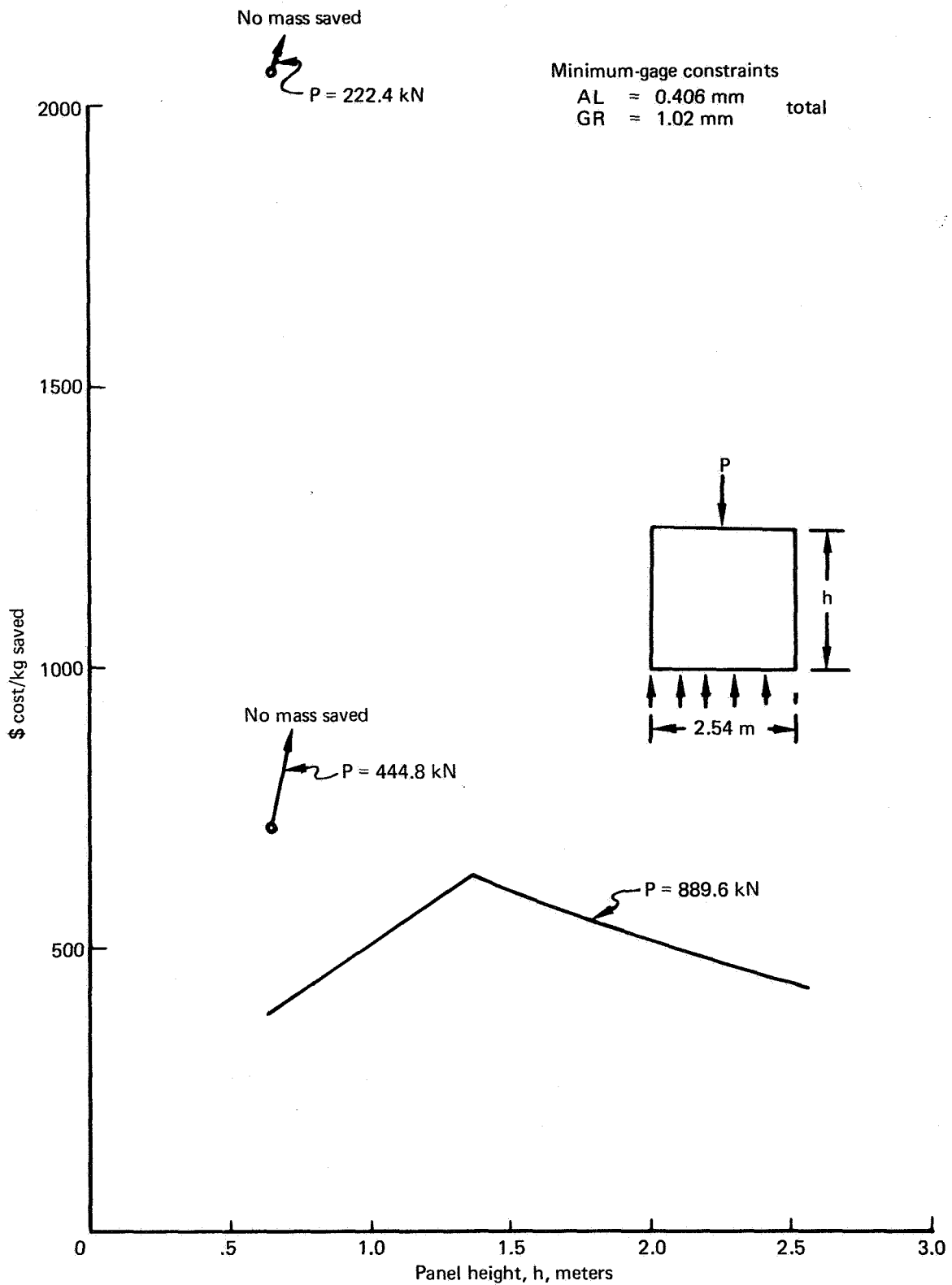

Figure 26.—Cost of Each Kilogram Saved by Use of Graphite Instead of Aluminum Skins on Compression Panels—With Minimum-Gage Constraints

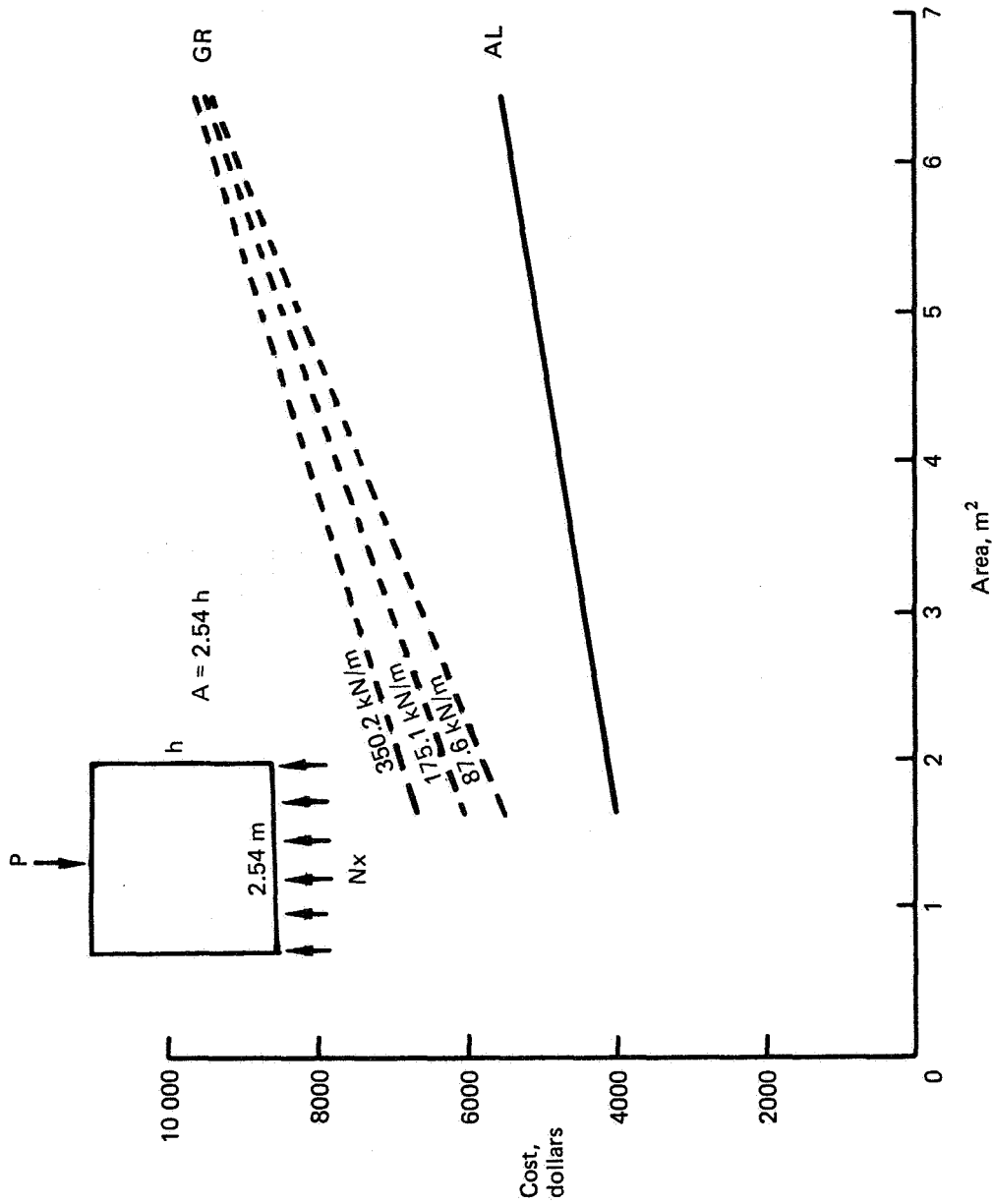
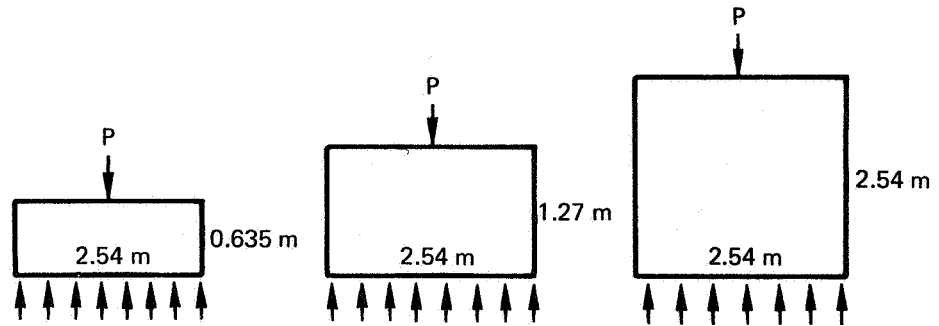

Figure 27.—Cost Per Panel (for 50 Units) for Various Area Panels Having Aluminum and Graphite Skins

Table 9.—Compression Panel Cost/Mass Comparison

Minimum-gage constraints
50-unit production



P = 222.4 kN			
Aluminum skin	457	286	182
Graphite skin	773	394	262
P = 444.8 kN			
Aluminum skin	314	227	152
Graphite skin	644	361	256
P = 889.6 kN			
Aluminum skin	192	160	115
Graphite skin	500	328	245

Note: All values shown are \$/kg unless otherwise specified.

PANEL PRELIMINARY DESIGN PROCEDURE

A large variety of panels having different combinations of load intensity, aspect ratio, size, and skin material may be preliminarily designed with the data bank information and the ratioing procedures developed. The master panel skin gage distributions to be used for preliminary design procedures are presented in figures 28 and 29.

The general procedure follows:

1. Choose panel aspect ratio, size, load intensity desired, and load reaction type.
2. Find appropriate master panel skin gage distribution figure.
3. Resize master panel skin gages by the ratio of the given load to the master panel unitized load of 175.1 kN/m.
4. Change the skin mass by the ratio found in step 3.
5. Adjust the skin mass by the ratio of panel area to master panel area.
6. Find a comparable aspect ratio panel in the STAGS-B data bank and note the buckling load and skin gage used.
7. Revise the buckling load for the selected panel size by multiplication of
$$\left(\frac{\text{Master panel } h}{\text{selected panel } h}\right)^2 \text{ (ratioed STAGS-B buckling load)}$$
8. Correct the revised buckling load by multiplying the ratio of the smallest skin gage occurring on the panel centerline to STAGS-B gage used on a similar aspect ratio panel.
9. Correct the buckling load of step 8 by multiplying the ratio of panel face modulus of elasticity (E) to STAGS-B example (if different face materials are used). This is now the projected buckling load for the panel with 25.4-mm-thick core, as the STAGS-B data bank used.
10. Find core thickness by dividing the load chosen for panel by the final corrected buckling load of step 9. Take the square root and multiply by 25.4 mm. This is the core thickness required for the panel, and the panel is now preliminarily sized.
11. If minimum-gage constraints are desired, find the percentage of skin mass increase from figures 14 or 15, and add to the adjusted skin mass found in step 5.
12. Determine core mass by multiplying the core thickness times the panel area times the assumed density.
13. Determine adhesive mass by multiplying panel area times 0.586 kg/m².

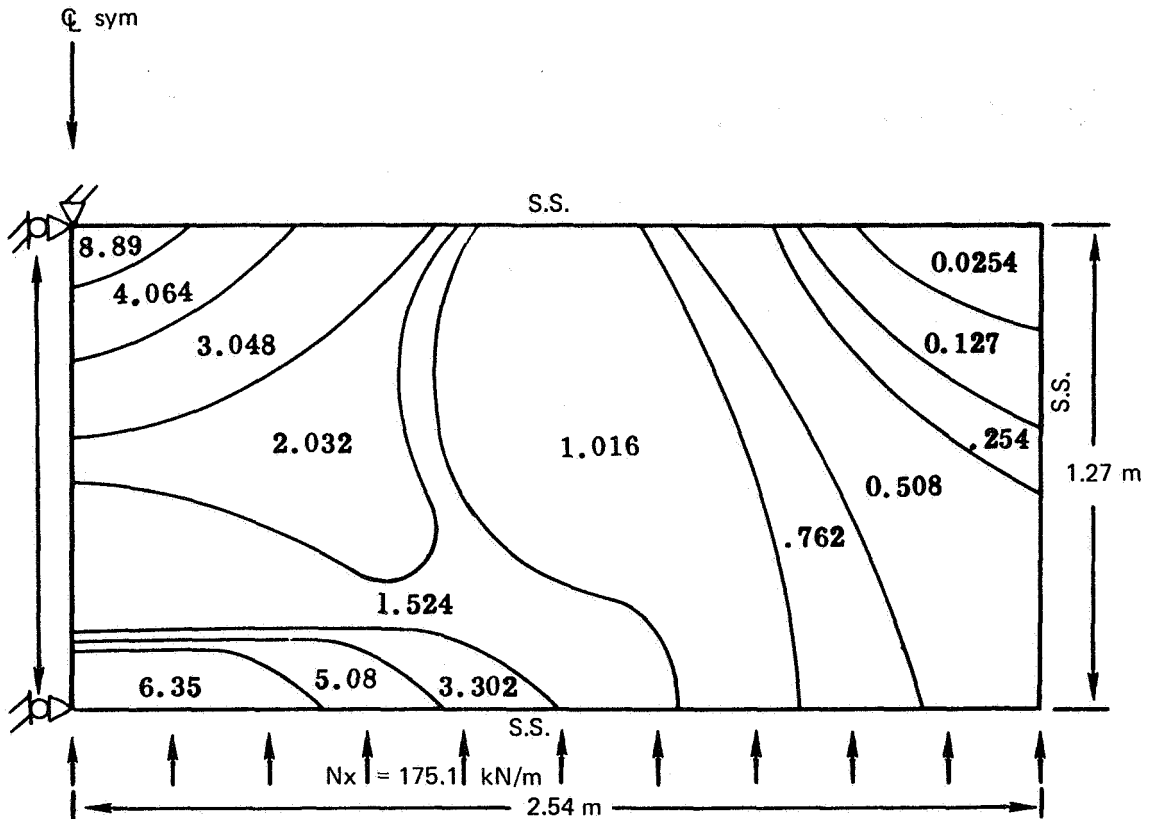

(a) AR = 0.25 (full panel); skin mass = 14.560 kg (half panel)

Note: Skin gage is the sum of both sandwich faces in millimeters.

Figure 28.—Master Panel Skin Gage Distribution for Aluminum 7075-T6 Skins

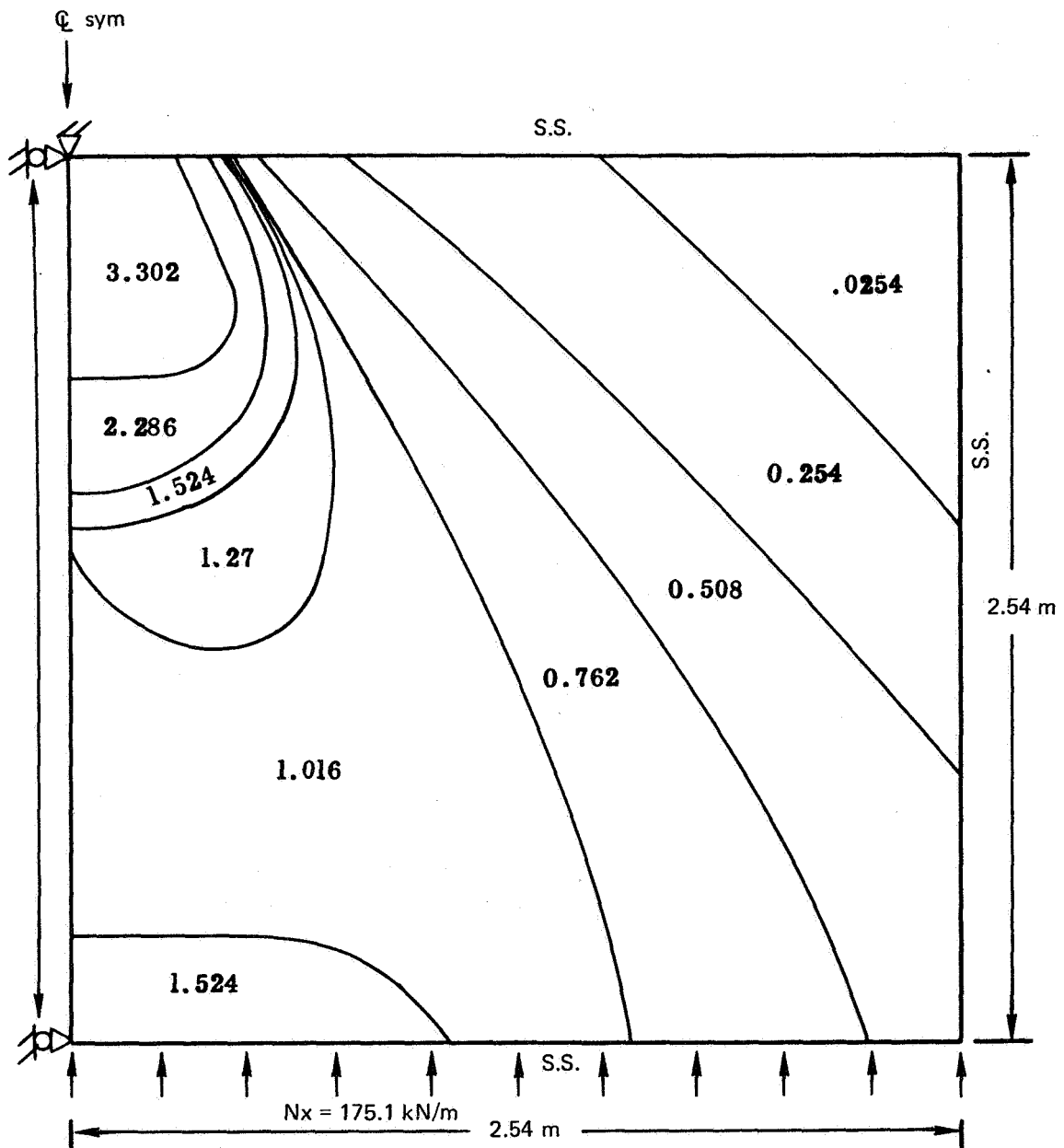

(b) AR = 0.50 (full panel); skin mass = 15.105 kg (half panel)
 Note: Skin gage is the sum of both sandwich faces in millimeters.

Figure 28.—(Continued)

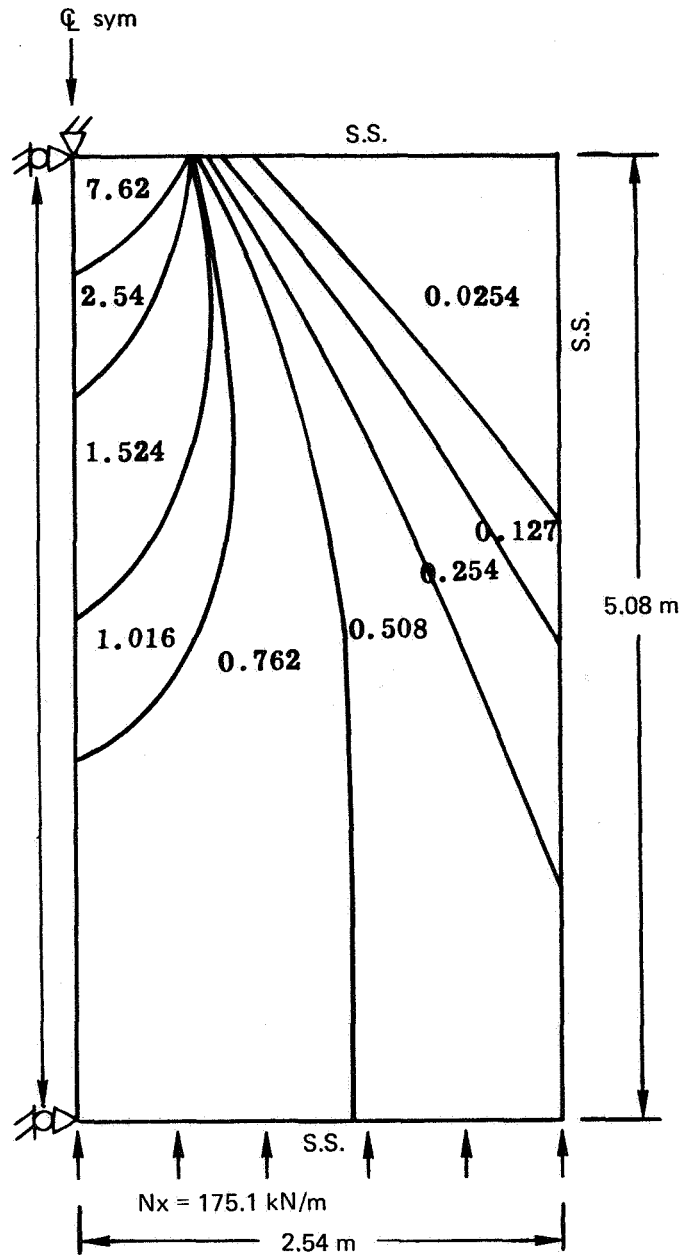

(c) AR = 1.0 (full panel); skin mass = 22.725 kg (half panel)
 Note: Skin gage is the sum of both sandwich faces in millimeters.

Figure 28.—(Continued)

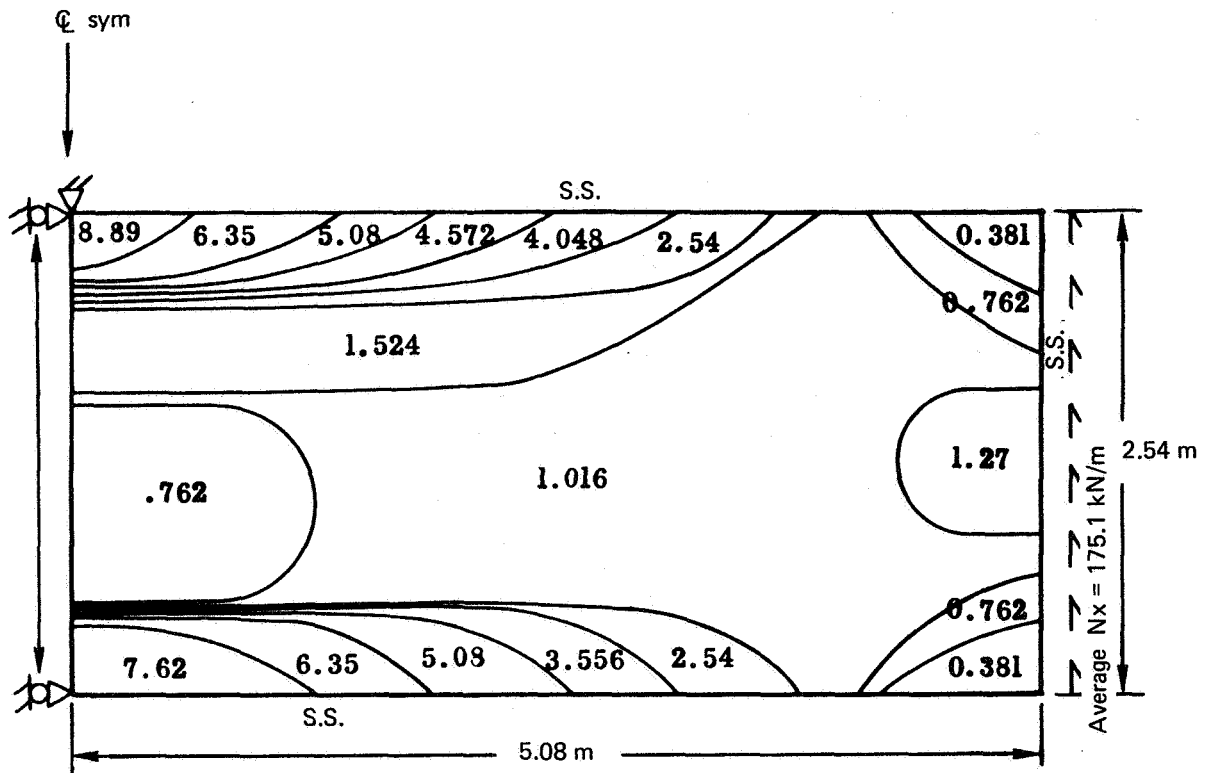

(d) AR = 0.25 (full panel); skin mass = 65.907 kg (half panel)

Note: Skin gage is the sum of both sandwich faces in millimeters.

Figure 28.—(Continued)

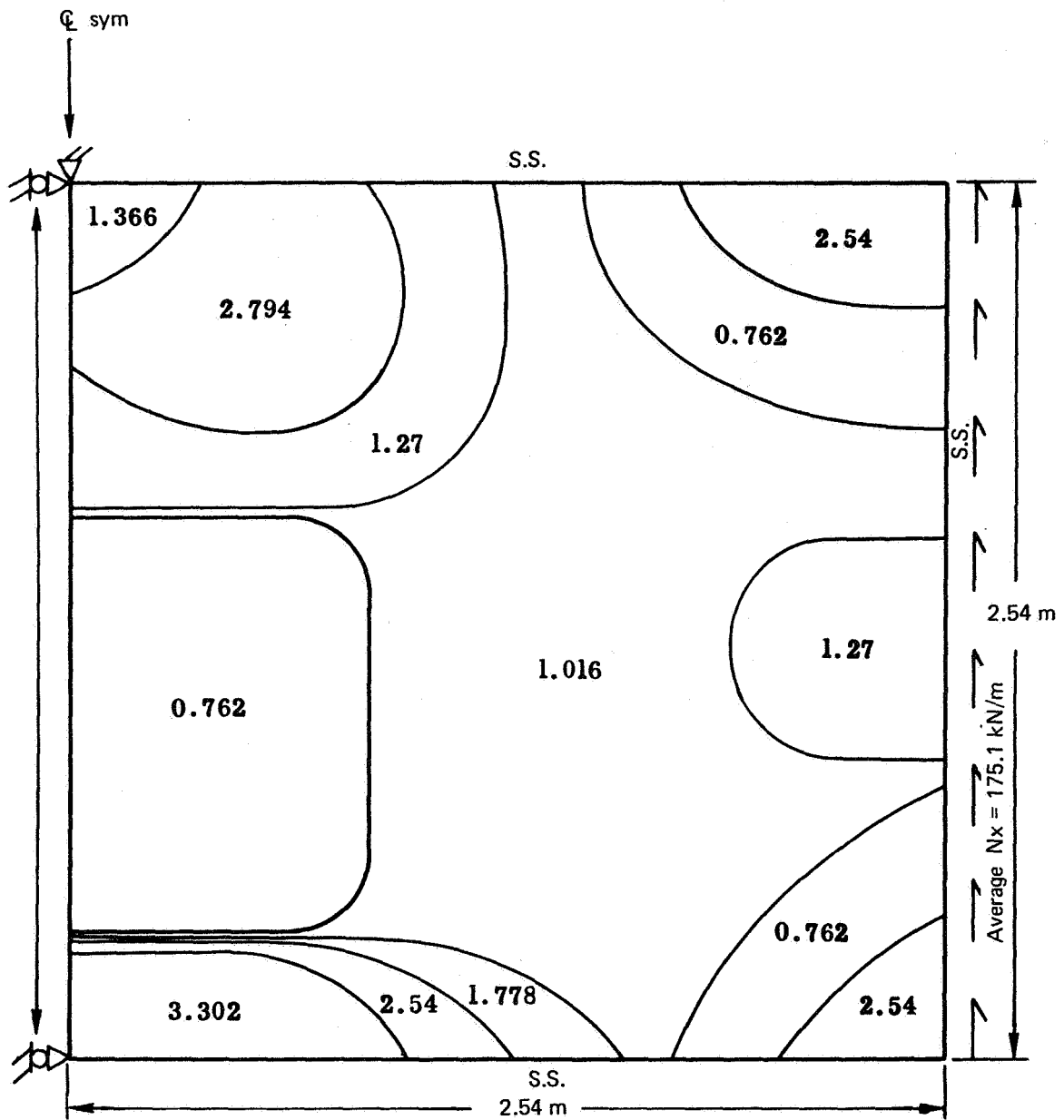

(e) AR = 0.50 (full panel); skin mass = 24.086 kg (half panel)
 Note: Skin gage is the sum of both sandwich faces in millimeters

Figure 28.—(Continued)

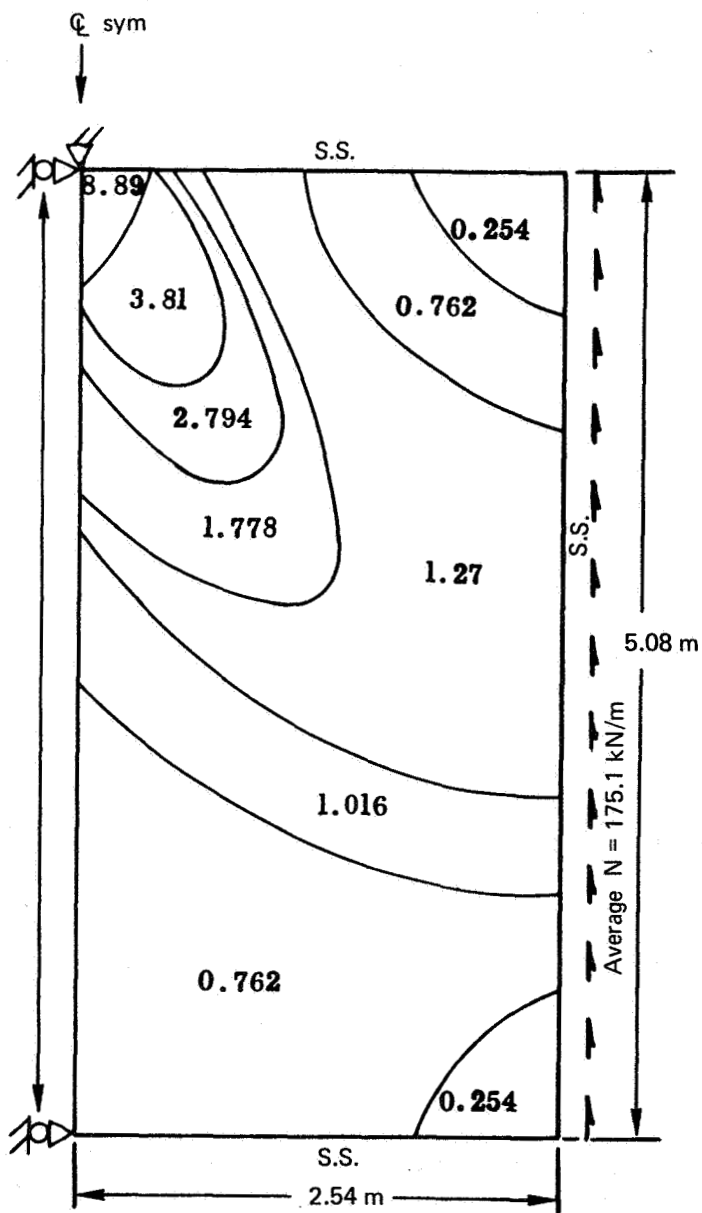

(f) AR = 1.0 (full panel); skin mass = 45.359 kg (half panel)
 Note: Skin gage is the sum of both sandwich faces in millimeters.

Figure 28.—(Concluded)

14. Determine fitting mass by increasing skin mass, core mass, and adhesive mass by $N/(1 - N)$ where N is the appropriate fitting-mass factor taken from figure 17 or 18.
15. Check for local failure effects from figures 6 and 7.
16. Make panel cost estimates using figure 27.

Naturally, if the panel being preliminarily sized is identical in some features to the master panel skin gage distribution panel, the data bank panels, or the STAGS-B example, some of the sizing ratios will become unity.

The two following examples are presented to show the preliminary design procedure.

PRELIMINARY DESIGN PROBLEM: Example 1

1. Preliminary size an aluminum-faced sandwich panel to transmit a uniform compression load of 122.57 kN/m (typical space tug type loading). The full panel dimensions are 635 mm in height and 1270 mm in width; aspect ratio of full panel is 0.50.
2. Figure 28b is the corresponding master panel skin gage distribution figure for aluminum skins, aspect ratio of 0.50, and uniform compression reaction. Skin mass for half-panel width is 15.1 kg. Total skin mass is 30.2 kg.
3. New skin gage distributions are ratioed for load by

$$\frac{122.57}{175.1} = 0.7$$

4. New skin mass is $(0.7)(30.2) = 21.1$ kg, for master panel size.
5. Area of panel is 0.0625 times that of master panel. Adjusted skin mass = $(0.0625)(21.1) = 1.32$ kg.
6. STAGS-B data contain a comparable case for uniform compression, aspect ratio 0.50, core 25.5 mm thick, and uniform $t = 1.02$ mm. Full panel size = 2.54 by 5.08 m, buckling load = 39.4 kN/m.
7. Revising the STAGS-B buckling load for the selected panel size,

$$\left(\frac{2.54}{0.635}\right)^2 (39.4) = 630 \text{ kN/m}$$

8. The smallest gage occurring on the panel centerline is 0.36 mm, which is found by multiplying the smallest gage on the centerline of figure 28b by the load ratios. (Remember, the master panel gages are total of both faces; STAGS-B data are listed as each skin gage.) Correcting the buckling load for skin gage,

$$\left(\frac{0.36}{1.02}\right) (630) = 222.4 \text{ kN/m}$$

9. No face modulus correction is necessary to buckling load since the design panel and STAGS-B panel data are both based on aluminum properties.
10. Finding core thickness required for selected load,

$$\left(\frac{122.57}{222.4}\right)^{1/2} (25.4) = 18.9 \text{ mm}$$

11. Minimum-gage constraints are desired. For the load selected and aspect ratio chosen, figure 14 indicates a 23% skin mass increase. Final total skin mass is $(1.23)(1.32) = 1.6$ kg.
12. Core mass calculation, $(0.0189)(0.635)(1.27)(49.63) = 0.76$ kg (assumed density = 49.63 kg/m^3).
13. Adhesive mass = $(0.586)(0.635)(1.27) = 0.47$ kg
14. Fitting-mass factor from figure 17 is 0.28. Increase skin mass, core mass, and adhesive mass by

$$\left(\frac{0.28}{1-0.28}\right)(1.6 + 0.76 + 0.47) = 1.1 \text{ kg}$$

15. Local failure effects check is acceptable.
16. Panel cost estimate from figure 27: panel area = 0.81 m^2 , load = 122.57 kN/m , panel cost = \$4000 each (50 units)
17. Final preliminary design:

- Compression-reacted panel
- Loading = 122.57 kN/m
- Size = 635 by 1270 mm
- Aspect ratio = 0.50
- Skins, aluminum
- Skin mass = 1.6 kg (minimum gage = 0.203 mm)
- Core thickness = 18.9 mm
- Core mass = 0.76 kg Adhesive mass = 0.47 kg Fitting mass = 1.1 kg
- Total panel mass = 3.93 kg
- Estimated fabrication cost = \$4000/panel (50 units)

PRELIMINARY DESIGN PROBLEM: Example 2

1. Preliminary size a panel having the same configuration and loading as Example 1, except make the skins of quasi-isotropic graphite-epoxy.
2. Figure 29b is the corresponding master panel skin gage distribution figure. Skin mass for half-panel width is 7.2 kg. Total skin mass is 14.4 kg.
3. New skin gage distributions are ratioed for load by

$$\left(\frac{122.57}{175.1}\right) = 0.7$$

4. New skin mass is $(0.7)(14.4) = 10.1$ kg for master panel size.
5. Area of panel is 0.0625 times that of master panel. Adjusted skin mass = $(0.0625)(10.1) = 0.63$ kg.
6. A similar case exists in the STAGS-B buckling data bank, but we will use the same aluminum case that was used in Example 1 so that a modulus correction is required. Size = 2.54 by 5.08 m, buckling load = 39.4 kN/m.
7. Correcting the STAGS-B buckling load for the selected panel size,

$$\left(\frac{2.54}{0.635}\right)^2 (39.4) = 630 \text{ kN/m}$$

8. The smallest single face gage occurring on the panel centerline is 0.27 mm, which is found by multiplying the smallest gage on the centerline of figure 29b by the load ratios. Correcting the buckling load for skin gage,

$$\left(\frac{0.27}{1.02}\right) (630) = 167 \text{ kN/m}$$

9. A facing modulus correction is required. From appendix A, the modulus of aluminum E is 71.02 GPa, the modulus of graphite E is 45.51 GPa. Correcting the buckling load of step 8,

$$\left(\frac{45.51}{71.02}\right) (167) = 107 \text{ kN/m}$$

10. Finding core thickness required for selected load,

$$\left(\frac{122.57}{107}\right)^{\frac{1}{2}} (25.4) = 27.2 \text{ mm}$$

11. Minimum-gage restraints are desired. For the load selected and the aspect ratio chosen, figure 15 indicates a 70% skin mass increase. Final total skin mass is $(1.7)(0.63) = 1.07$ kg.

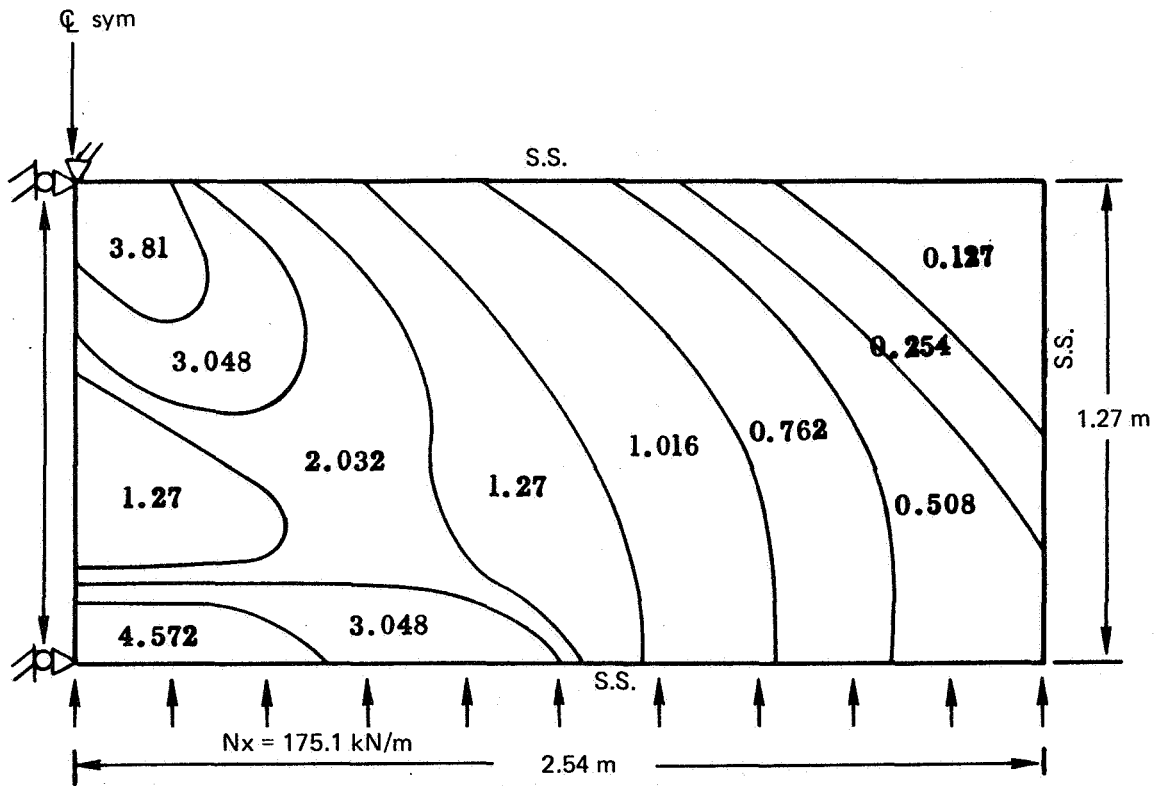

(a) AR = 0.25 (full panel); skin mass = 7.081 kg (half panel)

Note: Skin gage is the sum of both sandwich faces in millimeters.

Figure 29.—Master Panel Skin Gage Distribution for Intermediate Strength Graphite Skins

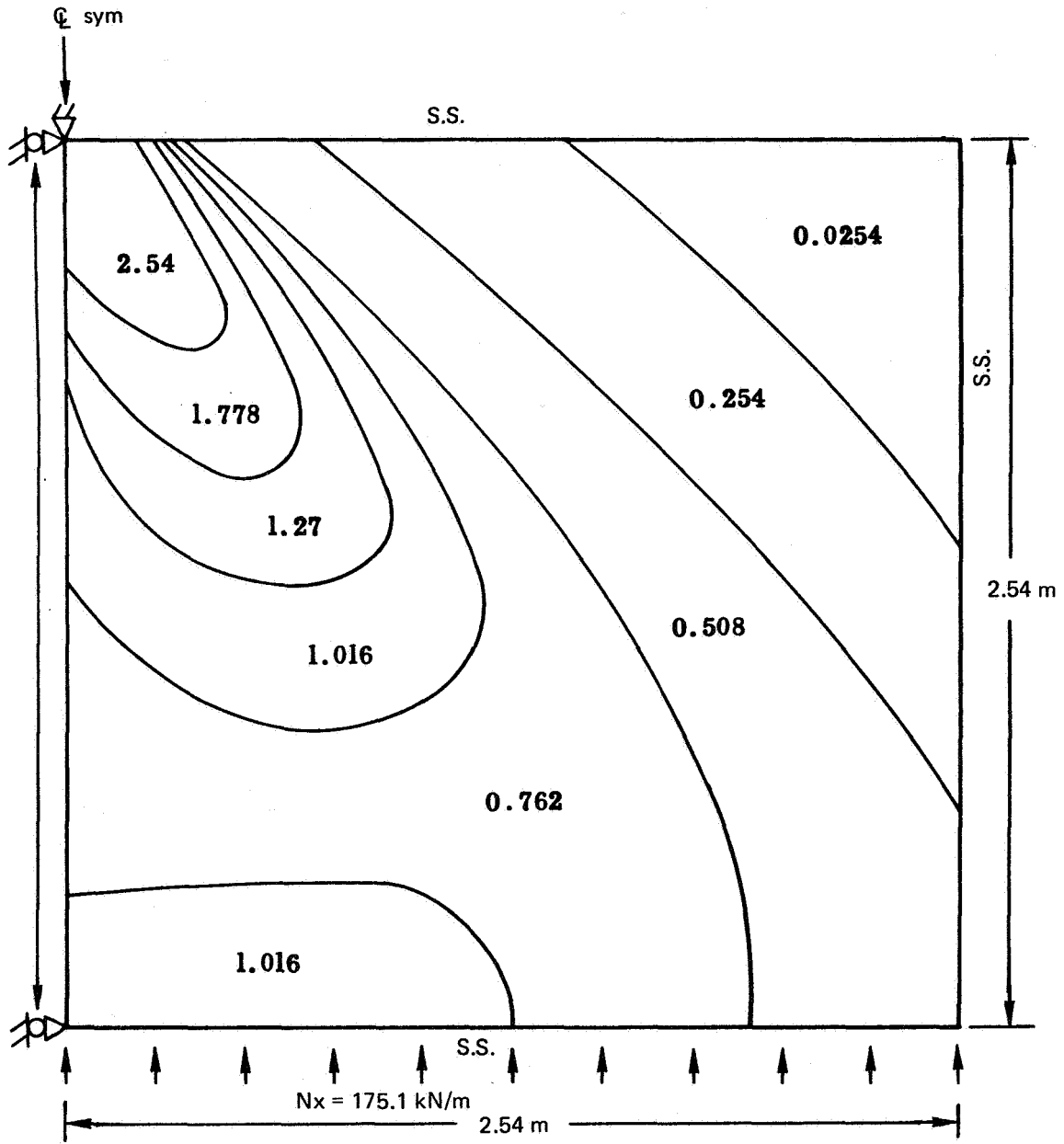

(b) AR = 0.50 (full panel); skin mass = 7.189 kg (half panel)
 Note: Skin gage is the sum of both sandwich faces in millimeters.

Figure 29.—(Continued)

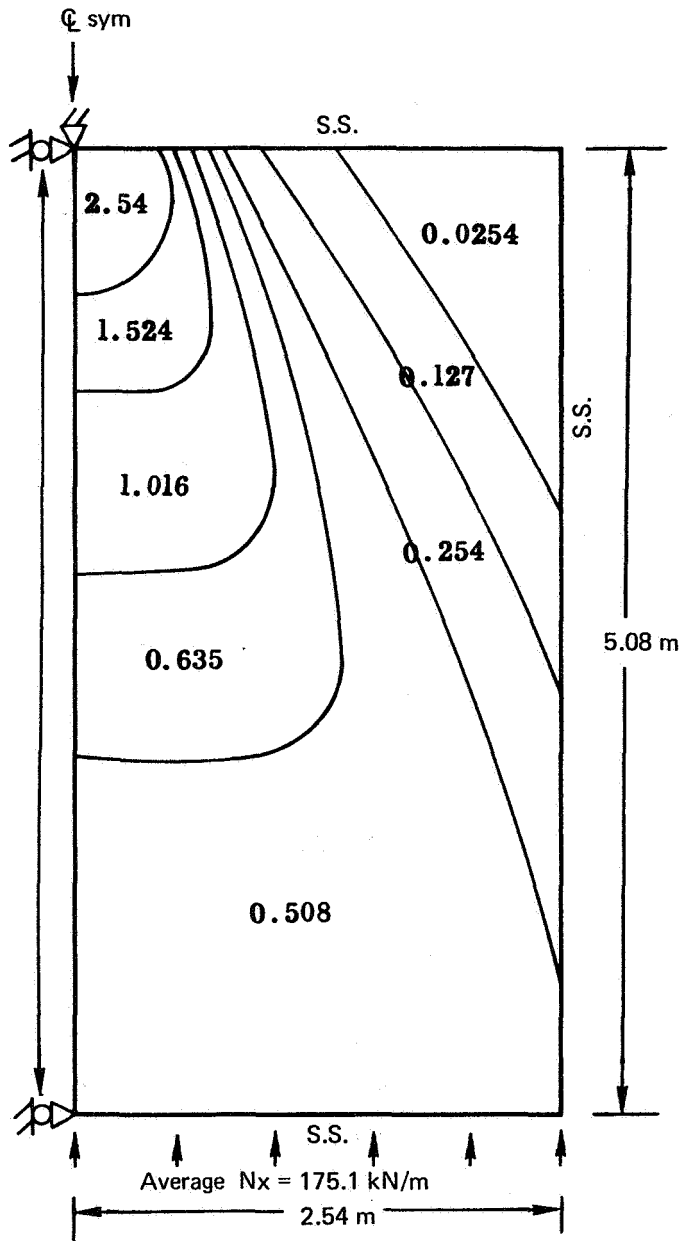

(c) AR = 1.0 (full panel); skin mass = 10.319 kg (half panel)
 Note: Skin gage is the sum of both sandwich faces in millimeters.

Figure 29.—(Continued)

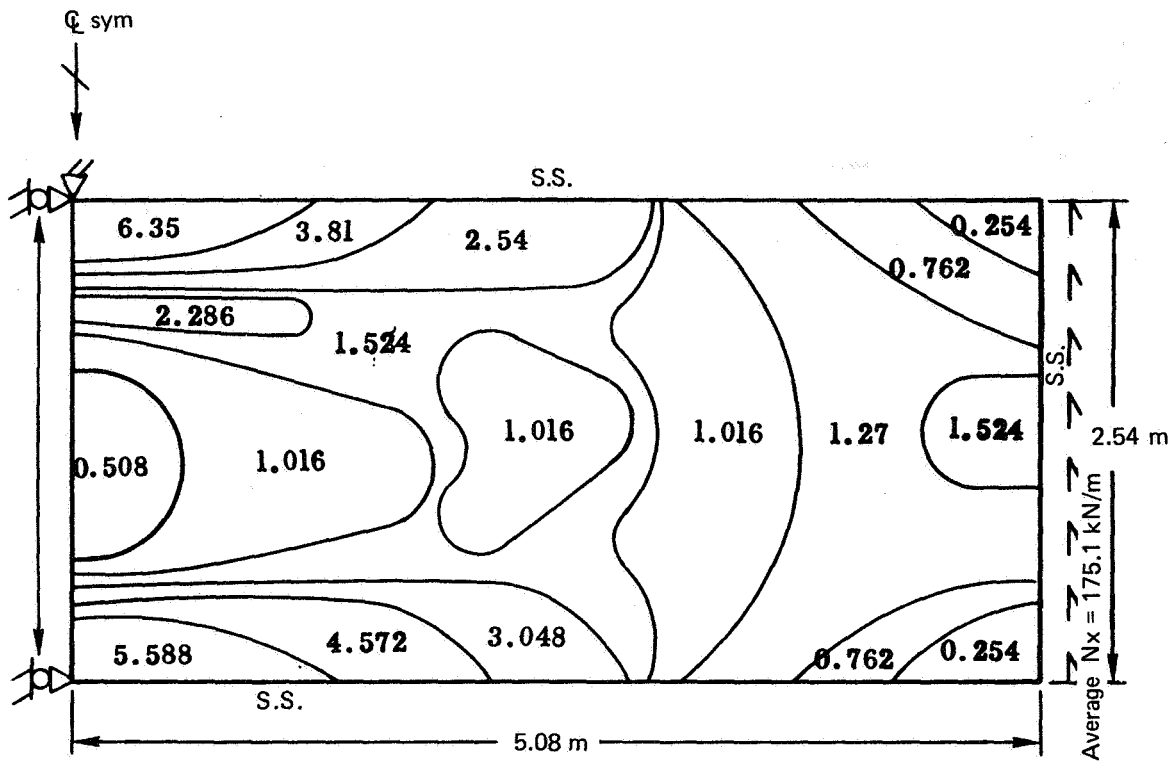

(d) AR = 0.25 (full panel); skin mass = 31.525 kg (half panel)
 Note: Skin gage is the sum of both sandwich faces in millimeters.

Figure 29.—(Continued)

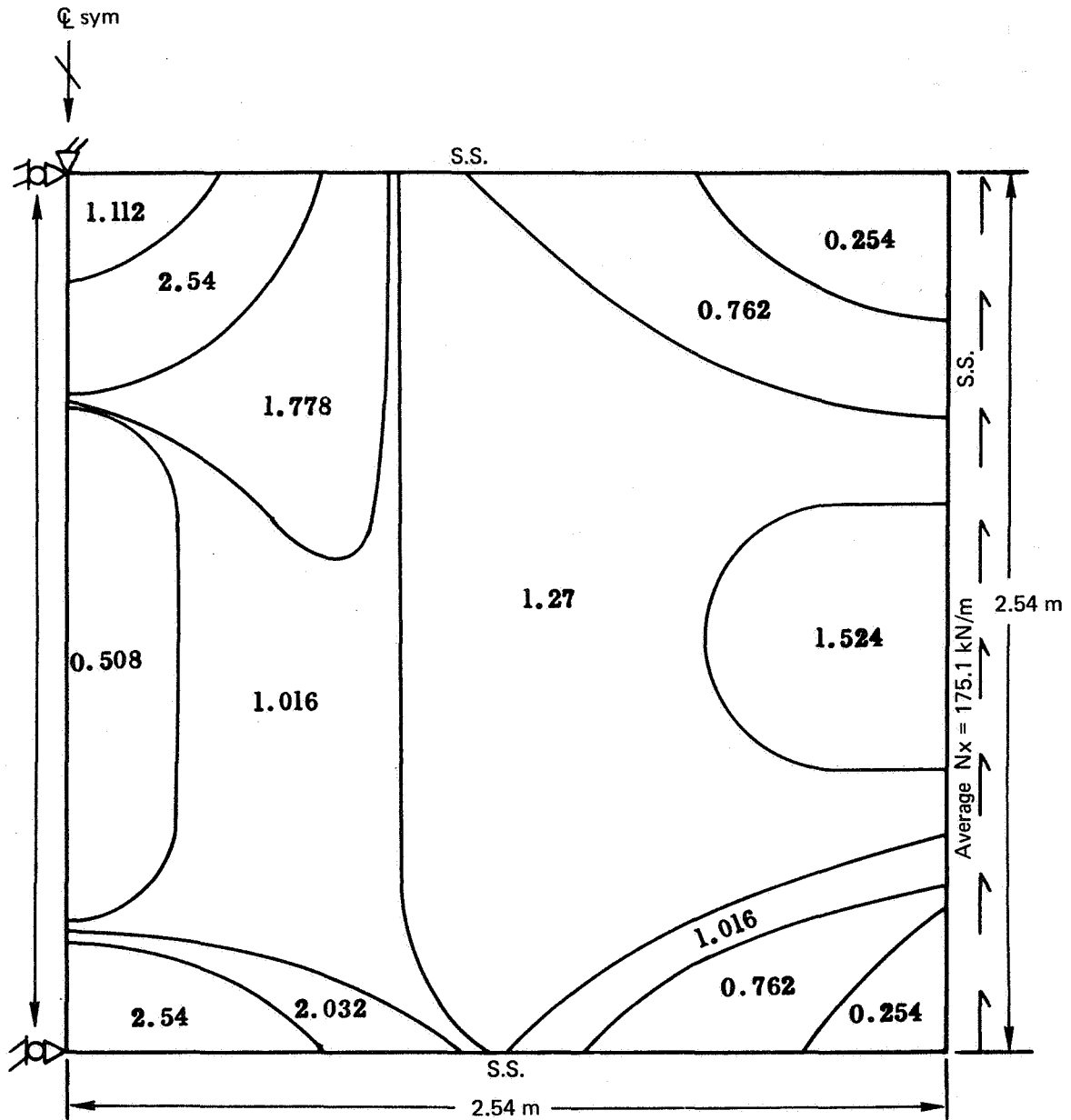

(e) AR = 0.50 (full panel); skin mass = 12.474 kg (half panel)
 Note: Skin gage is the sum of both sandwich faces in millimeters.

Figure 29.—(Continued)

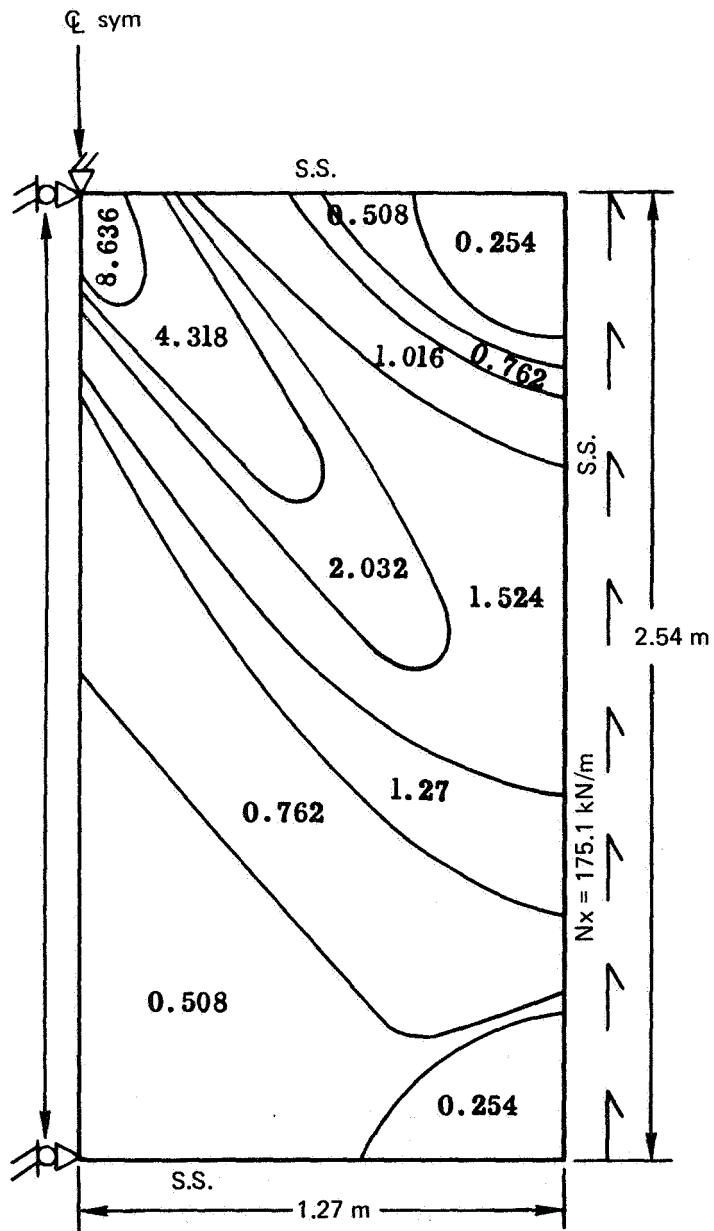

(f) AR = 1.0 (full panel); skin mass = 6.010 kg (half panel)

Note: Skin gage is the sum of both sandwich faces in millimeters.

Figure 29.—(Concluded)

12. Core mass calculation, $(0.0272)(0.635)(1.270)(49.63) = 1.09 \text{ kg}$ (assumed density = 49.63 kg/m^3)

13. Adhesive mass = $(0.586)(0.635)(1.27) = 0.47 \text{ kg}$

14. Fitting-mass factor increase from figure 18 is 0.21. Increase skin mass, core mass, and adhesive mass by

$$\left(\frac{0.21}{1-0.21}\right)(1.07 + 1.09 + 0.47) = 0.70 \text{ kg}$$

15. Local failure effects check is acceptable.

16. Panel cost estimate from figure 27: panel area = 0.81 m^2 , load = 122.57 kN/m , panel cost = \$5200 each (50 units)

17. Final preliminary design:

- Compression-reacted panel
- Loading = 122.57 kN/m
- Size = 635 by 1270 mm
- Aspect ratio = 0.50
- Skins, graphite, quasi-isotropic
- Skin mass = 1.07 (minimum gage = 0.51 mm)
- Core thickness = 27.2 mm
- Core mass = 1.09 kg Adhesive mass = 0.47 kg Fitting mass = 0.70 kg
- Total panel mass = 3.33 kg
- Estimated fabrication cost = \$5200/panel (50 units)

These sizing procedures are considered suitably accurate for preliminary designs. The procedures and data bank results allow a preliminary designer to size a panel of least mass for transmitting a given load. Without these tools, a specific design would require computer analysis or outright guesses. The skin-sizing technique is quite accurate. The core thickness sizing for buckling stability is more of an approximation but indicates sufficiently accurate estimates for preliminary design of compression panels. The shear-reacted panels present a more complex problem because of the highly variable skin gage distribution. Since the shear cases were secondary to the compression cases in this study, further investigation into this area was considered unjustified.

CONCLUSIONS

Techniques of establishing a preliminary honeycomb sandwich panel design have been presented. These techniques account for panel load intensity, panel size, panel aspect ratio, local instability, and general instability. Both aluminum and graphite skin materials are considered. The preliminary design techniques, along with the associated finite element and linear bifurcation theory STAGS-B buckling program data, provide the tools necessary for preliminary assessment of total panel mass. A fabrication cost data presentation allows cost estimates for the preliminary designed panels.

It was found that the shorter, low aspect ratio panels were the least mass panels. It was also found that the higher loaded panels were structurally more efficient than the lower loaded panels. Graphite skins did not always result in panel masses less than panels having aluminum skins for the same load intensities and with minimum-gage restrictions. Different minimum gages than used in this study would give other results.

The Boeing Company
P.O. Box 3707
Seattle, Washington 98124
February 11, 1976

APPENDIX A MATERIAL AND FIBER PROPERTIES

Table A-1.—Properties Used in This Study

Material Properties			
Symbol	Aluminum	Graphite, ISG, quasi-isotropic, 0°, ±45°, 90°	
E	71.02 GPa	45.51 GPa	
G	26.68 GPa	17.93 GPa	
F _s	225.32 MPa	193.05 MPa	
F _t	328.19 MPa	427.47 MPa	
F _c	328.19 MPa	448.16 MPa	
ρ	2.85 Mg/m ³	1.55 Mg/m ³	
μ	0.33	0.269	

Fiber Properties Used for Optimized Layups				
Symbol	ISG	HSG	HMG	
E _x	117.21 GPa	144.79 GPa	172.37 GPa	
E _y	11.72 GPa	11.72 GPa	11.72 GPa	
G	4.48 GPa	4.48 GPa	4.48 GPa	
F _{tx}	1.10 GPa	1.24 GPa	0.76 GPa	
F _{ty}	206.84 MPa	206.84 MPa	206.84 MPa	
F _{cx}	1.10 GPa	1.24 GPa	0.76 GPa	
F _{cy}	206.84 MPa	206.84 MPa	206.84 MPa	
ρ	1.55 Mg/m ³	1.55 Mg/m ³	1.55 Mg/m ³	
μ	0.21	0.21	0.21	

Honeycomb Core Properties	
ρ	49.63 kg/m ³
G _L	220.6 MPa
E _c	337.8 MPa

APPENDIX B

STRENGTH/MASS COMPUTER DATA, EXAMPLE

Two examples are presented for potential reproducibility checks on results. The computer input information and output results are presented.

EXAMPLE 1: GRAPHITE SKIN COMPRESSION PANEL

Panel size, 2.54 by 2.54 m (half width)
Uniform compression reaction, 175.1 kN/m
Quasi-isotropic graphite material properties

E	=	45.51 GPa
G	=	17.93 GPa
F _t	=	427.47 MPa
F _c	=	448.16 MPa
F _s	=	193.05 MPa
ρ	=	1.55 Mg/m ³
μ	=	0.269

Edges were simply supported with inplane deflections allowed, except the \bar{C} edge which allowed no y-axis deflection.

The fully stressed skin thickness (total) distribution is shown in figure B-1. The finite element plate stresses are shown in figure B-2.

The inplane nodal translation pattern from the finite element analysis on the skin plate is shown in figure B-3.

The total skin gages actually input to the STAGS-B general instability code and the output buckling load are shown in figure B-4.

The half-panel skin mass for no minimum gage is 7.189 kg (figure 29b).

The fitting-mass estimate would be calculated by fully sizing the panel as detailed in the example sizing problems.

EXAMPLE 2: ALUMINUM SKIN COMPRESSION PANEL

Panel size, 2.54 by 2.54 m (half-width)
Uniform compression reaction, 175.1 kN/m
Aluminum material properties (elastic)

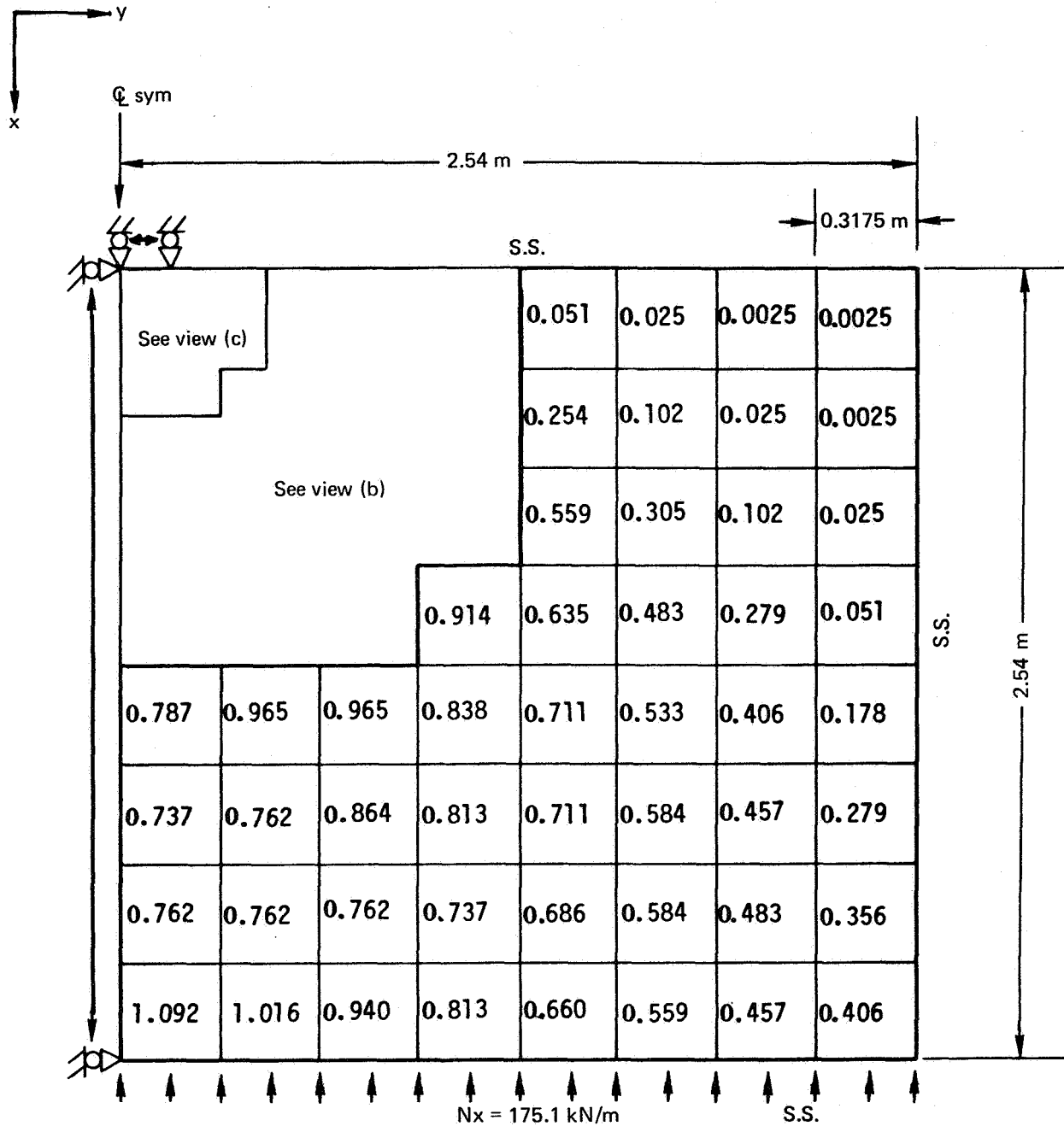

(a) Skin Gage Distribution (Total), mm

Figure B-1.—Finite Element Model, Skin Gage Distribution

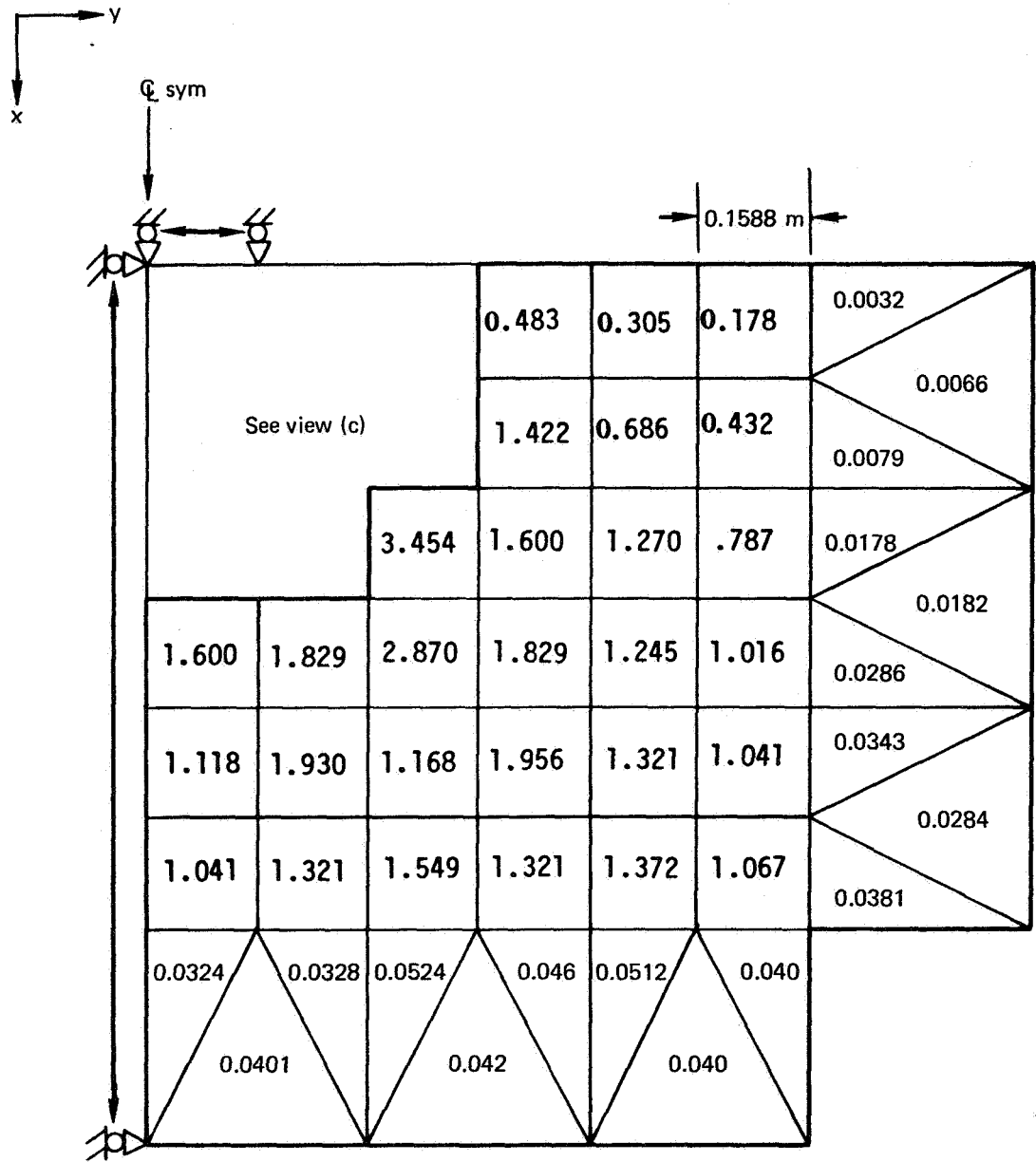

(b) Skin Gage Distribution in Loaded Corner of View (a) (Total), mm

Figure B-1.—(Continued)

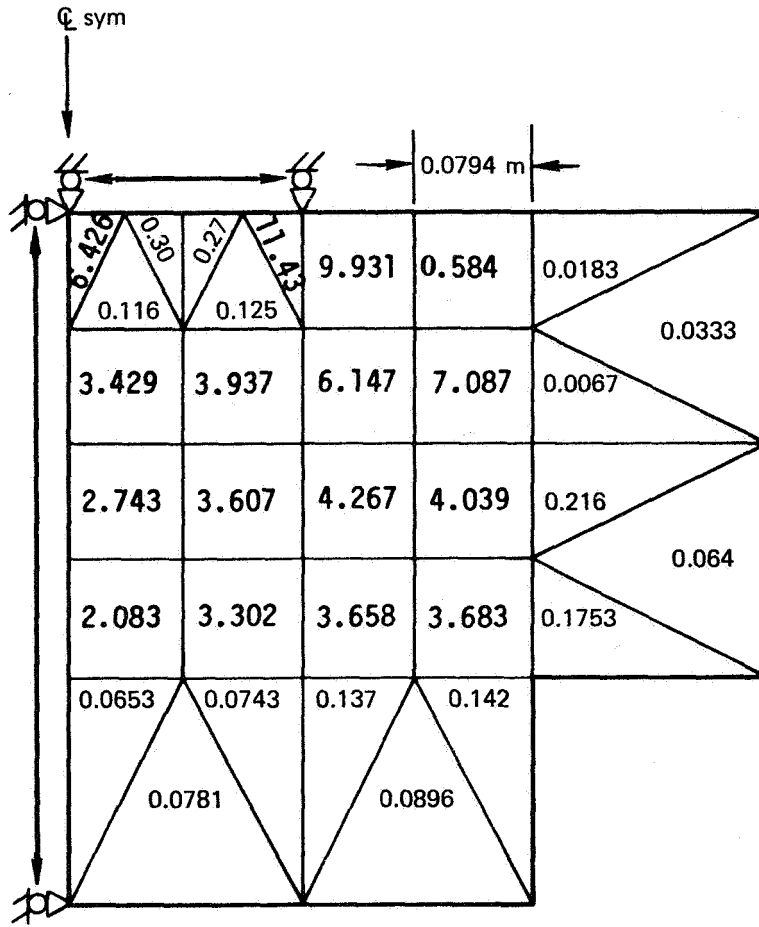

(c) Skin Gage Distribution in Loaded Corner of View (b) (Total), mm

Figure B-1.—(Concluded)

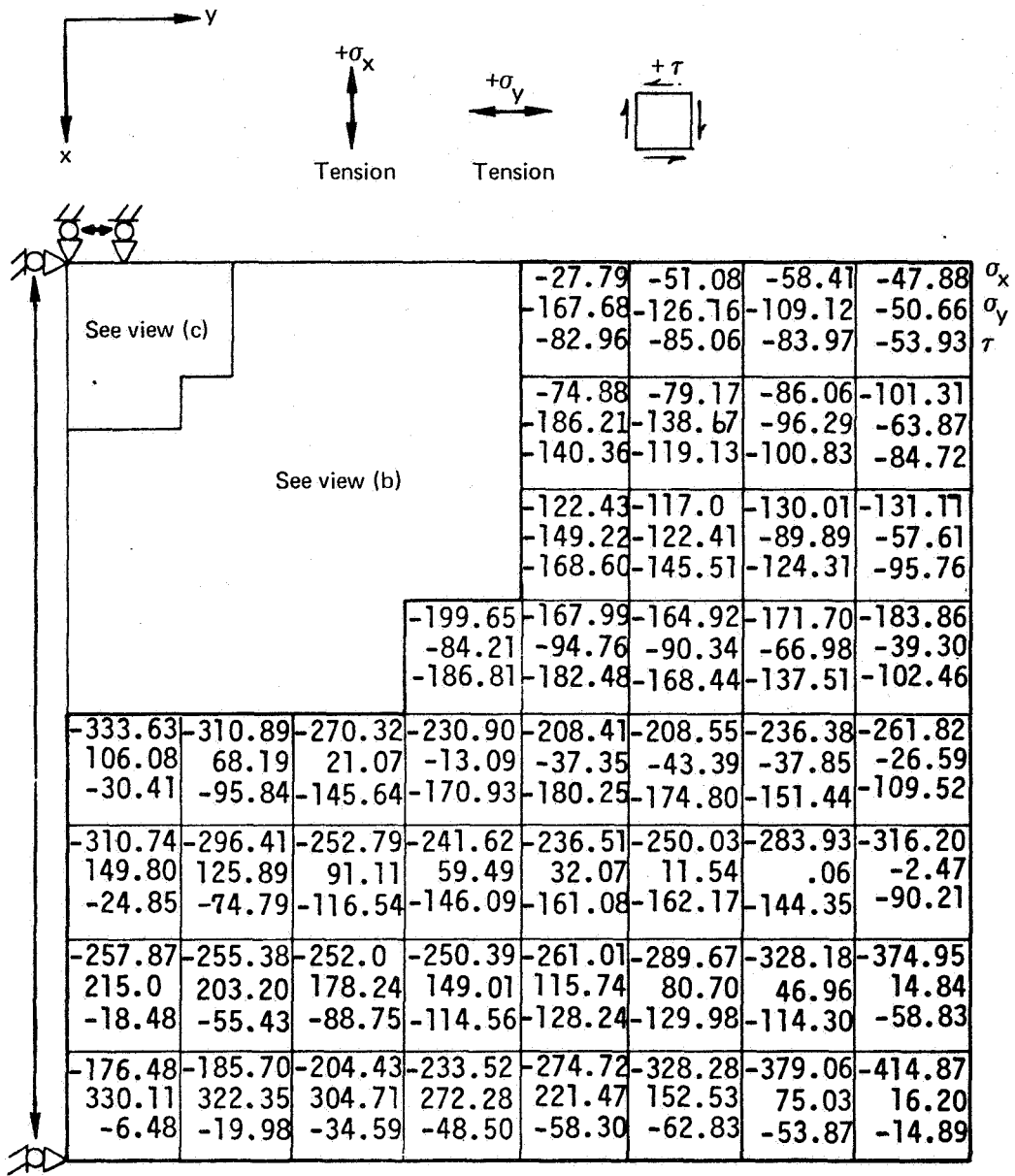

(a) Plate Stresses, MPa

Figure B-2.—Finite Element Model, Plate Stresses

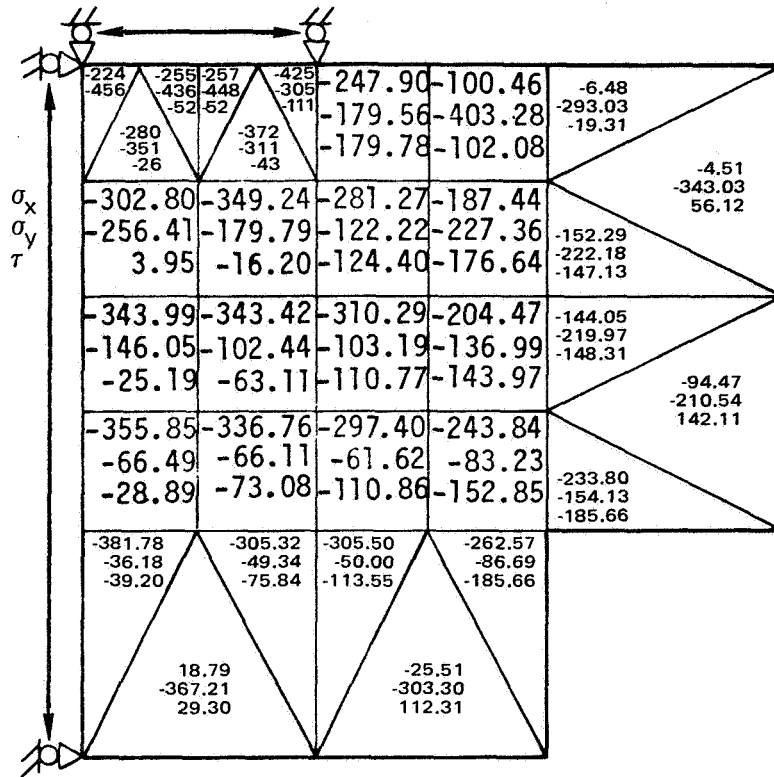

(c) Plate Stresses in Corner of View (b), MPa

Figure B-2.—(Concluded)

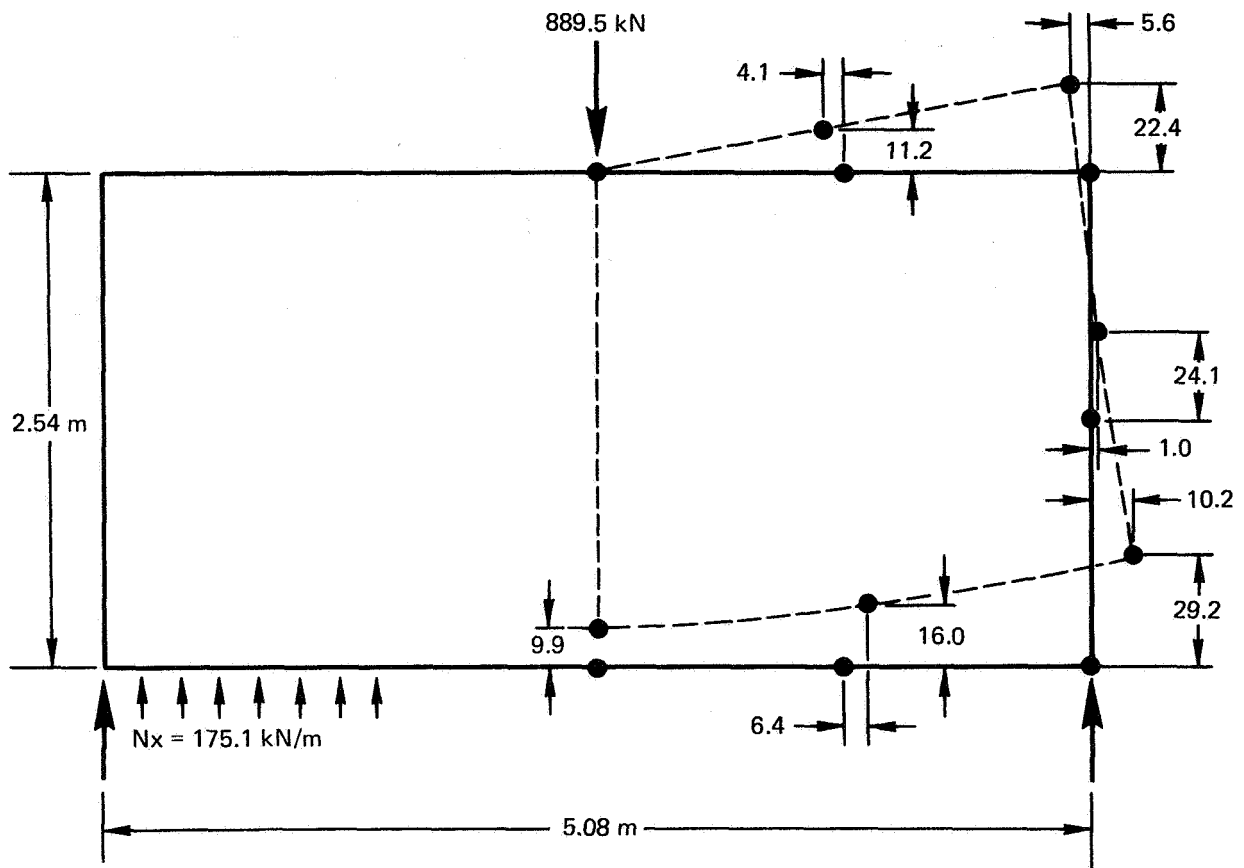

Note: Dimensions are in millimeters unless otherwise noted.

Figure B-3.—Typical Distortion Pattern (Exaggerated)—Graphite-Compression

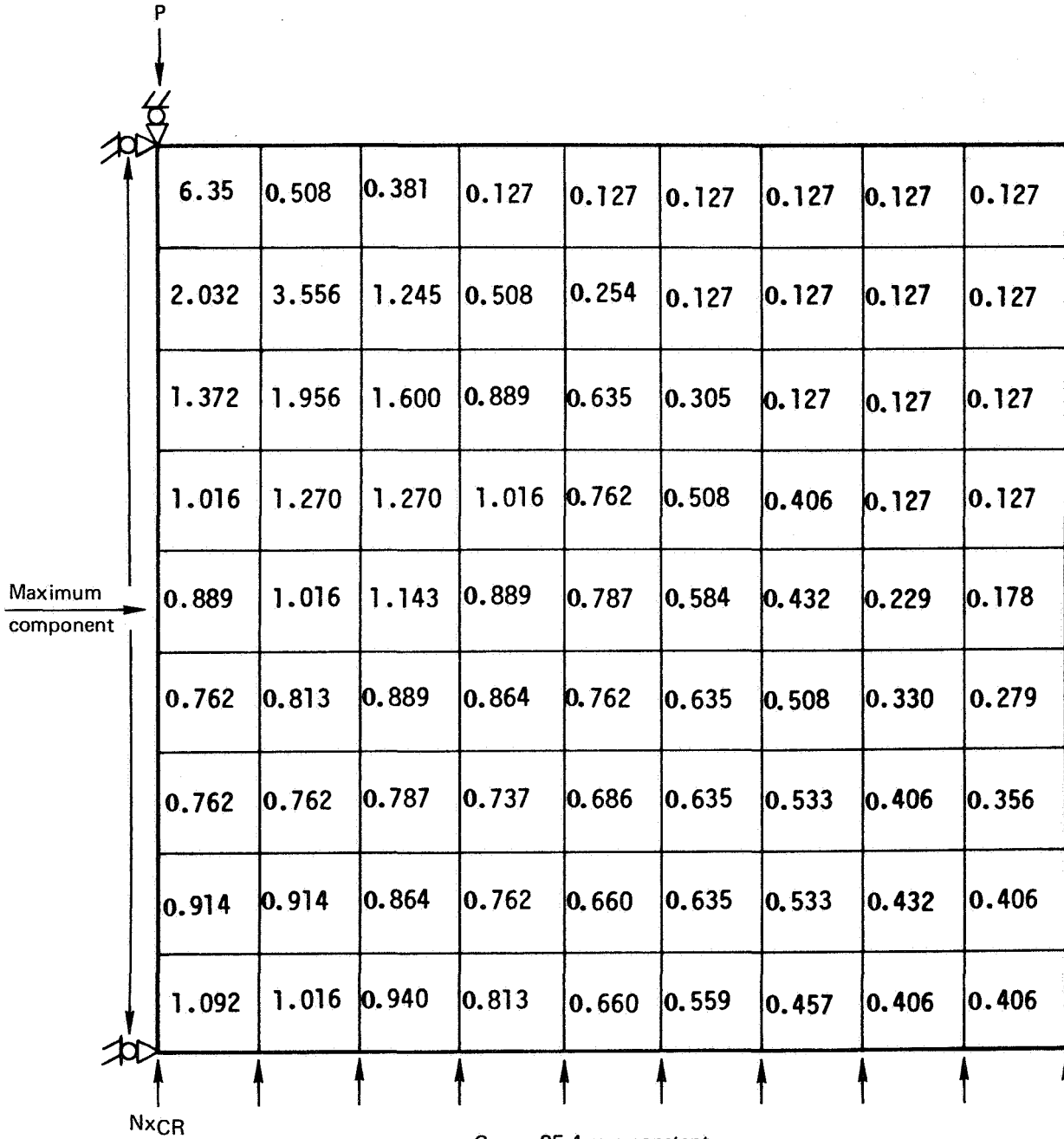

Core = 25.4-mm constant
 Buckling load = 10.20 kN/m
 Shifts permitted = 2
 Iterations permitted = 20

Figure B-4.—STAGS-B Model, Skin Gage Input (Total) in Millimeters

$$\begin{aligned}
E &= 71.02 \text{ GPa} \\
G &= 26.68 \text{ GPa} \\
F_t &= 328.19 \text{ MPa} \\
F_c &= 328.19 \text{ MPa} \\
F_s &= 225.32 \text{ MPa} \\
\rho &= 2.85 \text{ Mg/m}^3 \\
\mu &= 0.33
\end{aligned}$$

Edges were simply supported with inplane deflections allowed, except the \bar{C} edge which allowed no y-axis deflection.

The fully stressed skin thickness (total) distribution is shown in figure B-5. The finite element plate stresses are shown in figure B-6.

The half-panel skin mass for no minimum gage is 15.105 kg (figure 28b).

The fitting-mass estimate would be calculated by fully sizing the panel as detailed in the example sizing problems.

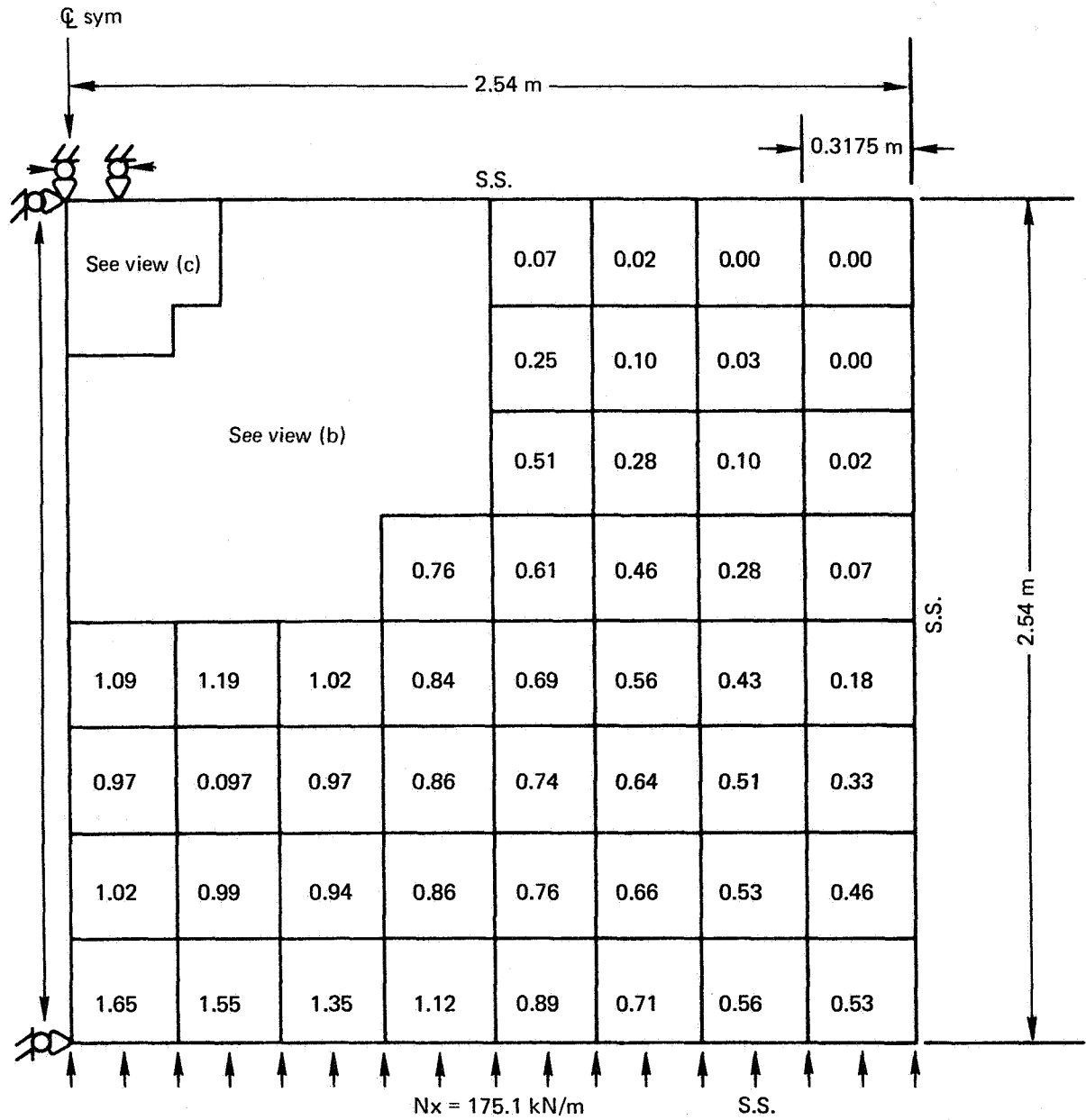

(a) Skin Gage Distribution (Total), mm

Figure B-5.—Finite Element Model, Skin Gage Distribution

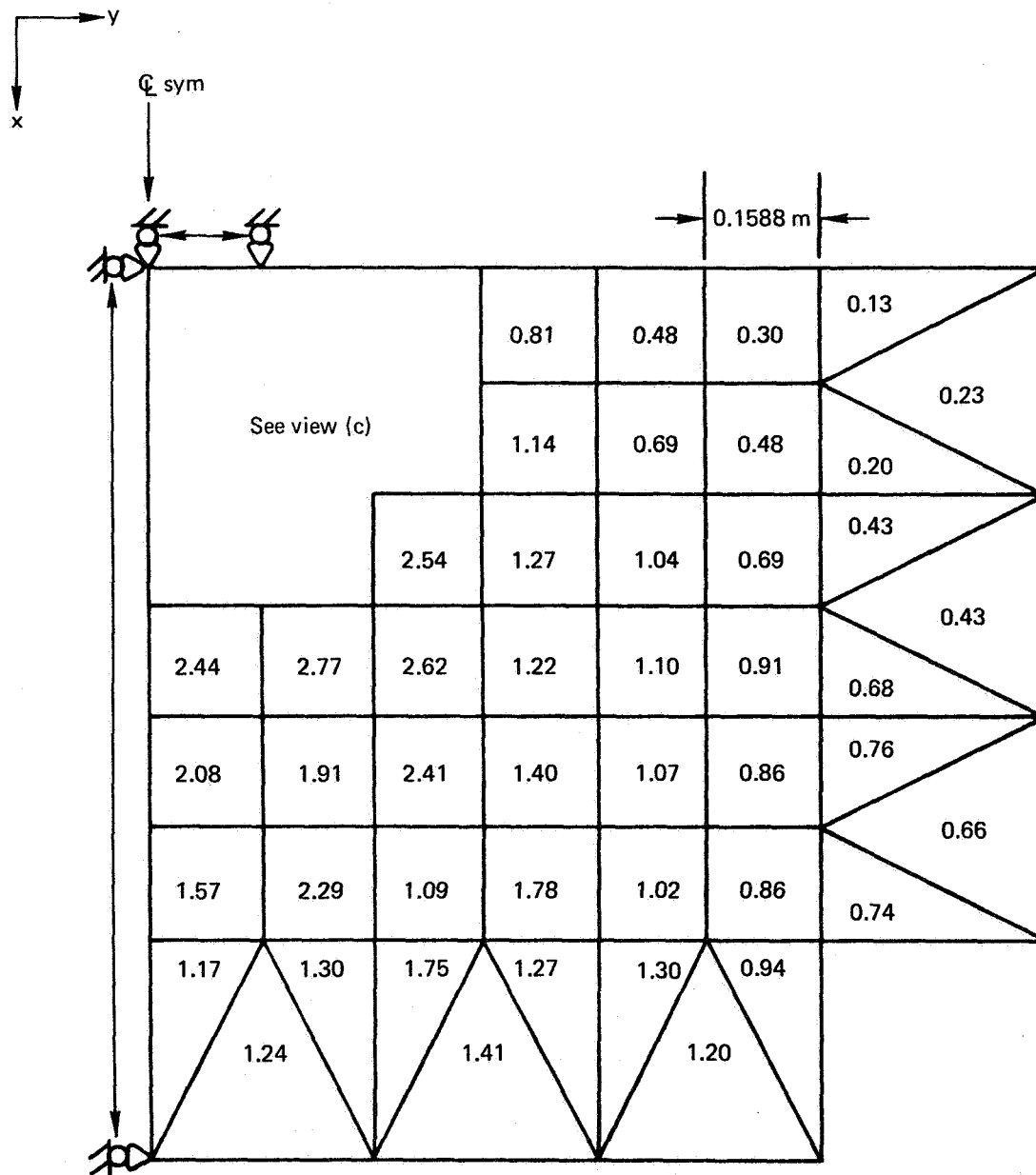

(b) Skin Gage Distribution in Loaded Corner of View (a) (Total), mm

Figure B-5.—(Continued)

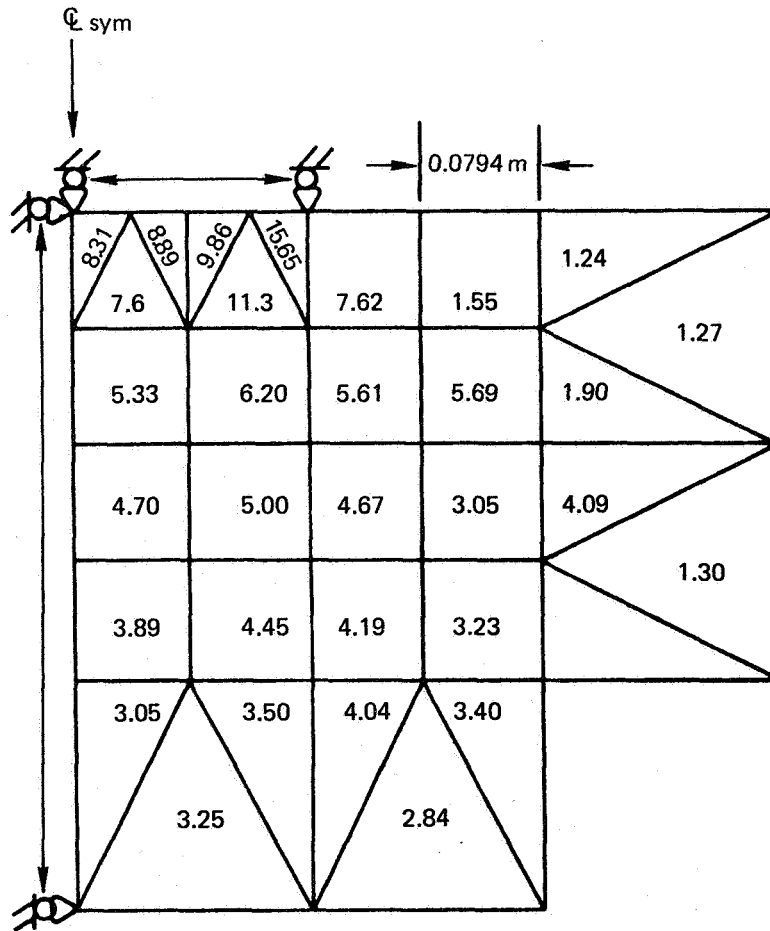

(c) Skin Gage Distribution in Loaded Corner of View (b) (Total)

Figure B-5.—(Concluded)

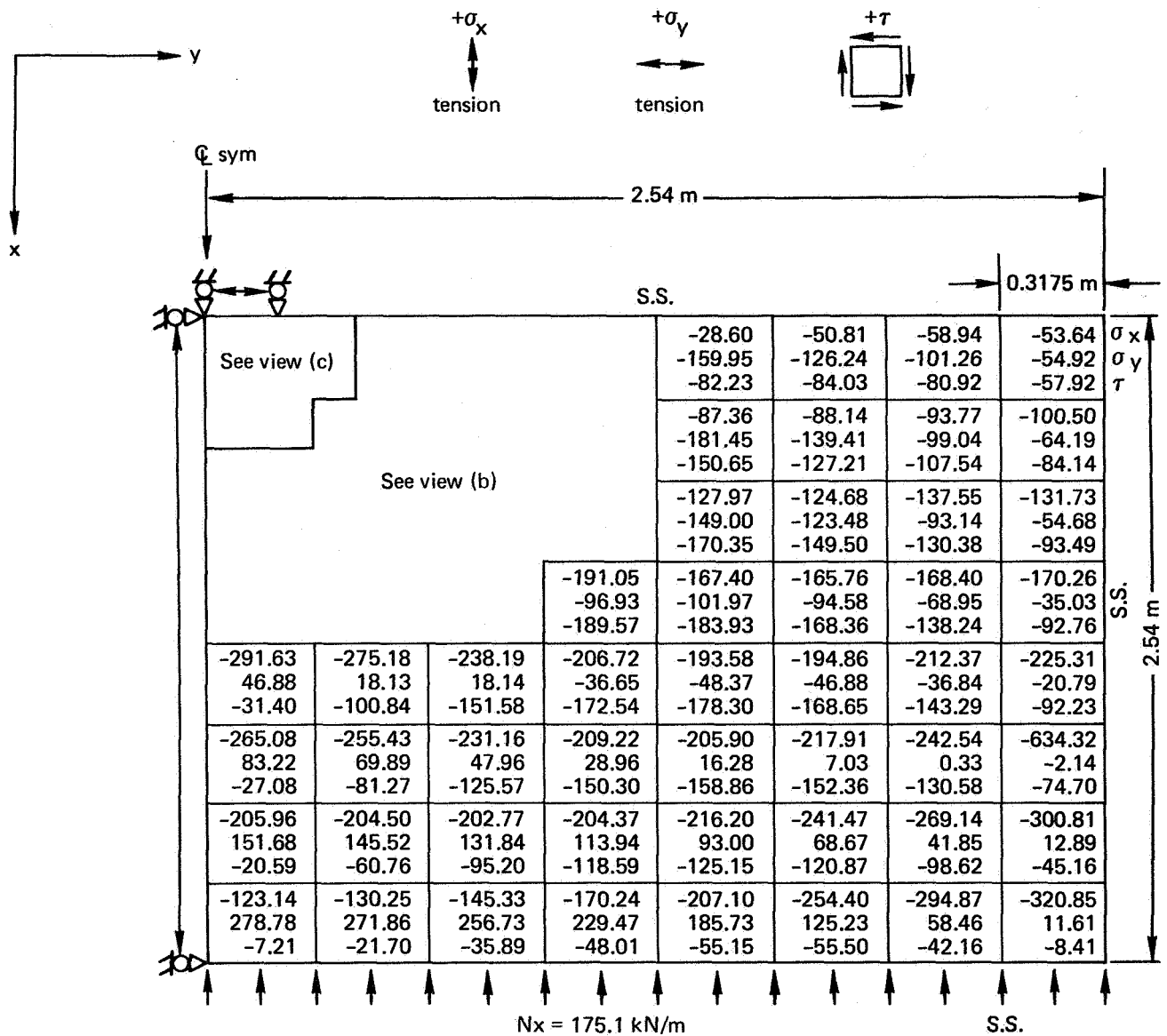

(a) Plate Stresses, MPa

Figure B-6.—Finite Element Model, Plate Stresses

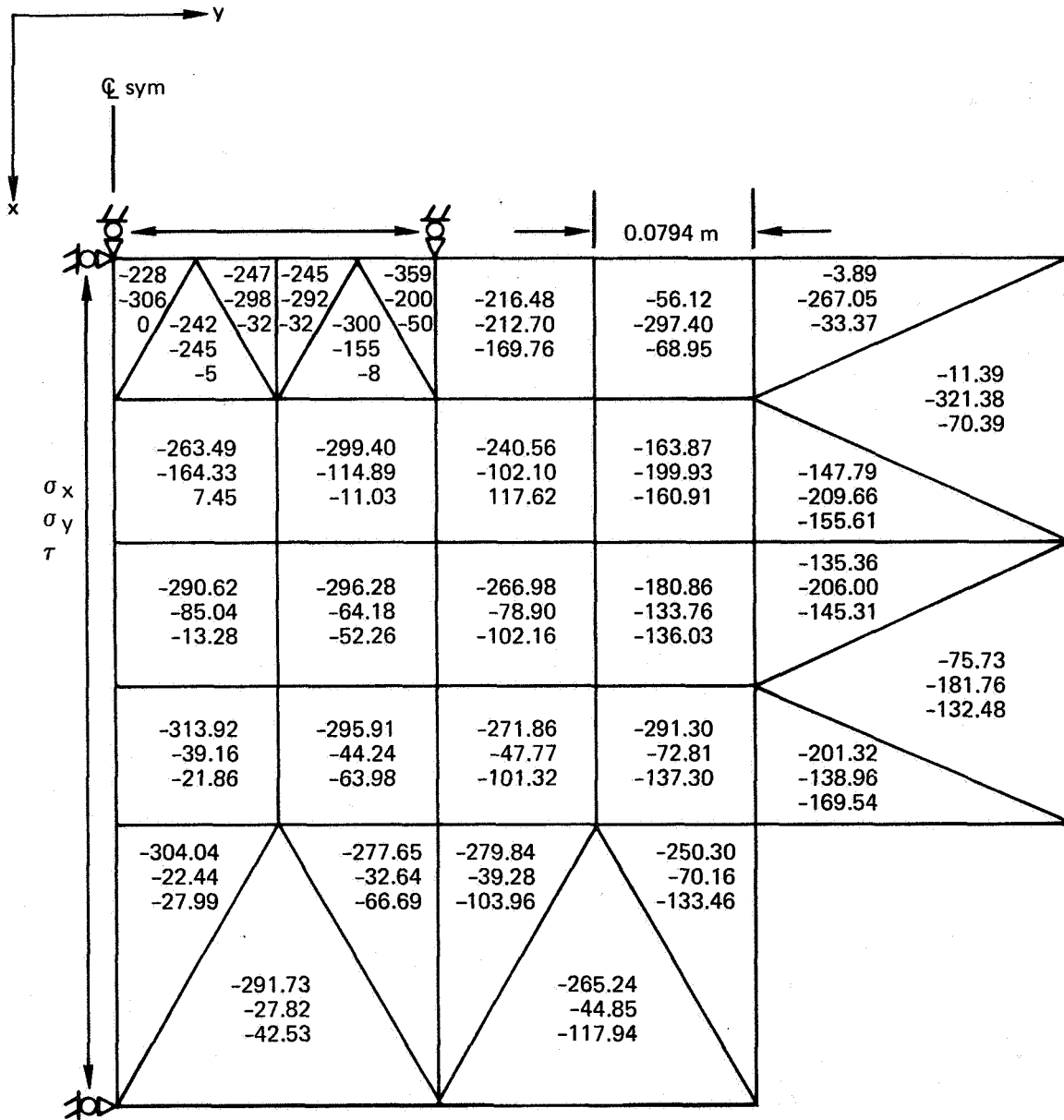

(c) Plate Stresses in Corner of View (b), MPa

Figure B-6.—(Concluded)

APPENDIX C TEST PANEL DESIGN AND FABRICATION

This appendix outlines the design, analysis, and fabrication of two small, example panels.

These demonstration panels were fabricated at the Boeing Auburn, Washington manufacturing facility. Both panels were designed to sustain a load of 112.1 kN. The edge conditions were the same as for the master panels, that is, simply supported. One panel was designed for shear and the other for compression. The graphite-epoxy skin gages were sized from the program baseline data bank. The core thickness was also selected from ratioed baseline buckling data. The load fittings were not optimized with respect to mass.

The graphite skins were layed up and precured under a pressure of 689 kPa and temperature of 450 K for 7.2 ks.

The skins, core, fittings, and adhesive assembly were cured under a pressure of 241 kPa and temperature of 394 K for 5.4 ks.

The size for both panels was 305.8 by 305.8 mm. Materials used in the panels were:

- Skins, Fiberite X934 resin, Thornel T300 fiber
- Core, 3.18-mm cell, 25.4-mm wall, 5052 aluminum
- Adhesive, 3M, AF126
- Core-fitting splice, Adhesive Engineering, Aerobond 3050
- Fittings, 6Al-4V annealed titanium plate

The actual material properties of this material by test were:

- $F_t = 521.3 \text{ MPa}$ ($0^\circ, \pm 45^\circ, 90^\circ$ layup)
- Interlaminar shear = 101.4 MPa

The practical skin gage layups selected are shown overlayed on the master panel fully stressed skin gages in figures C-1 and C-2.

Photographs of the two panels are shown in figures C-3 and C-4.

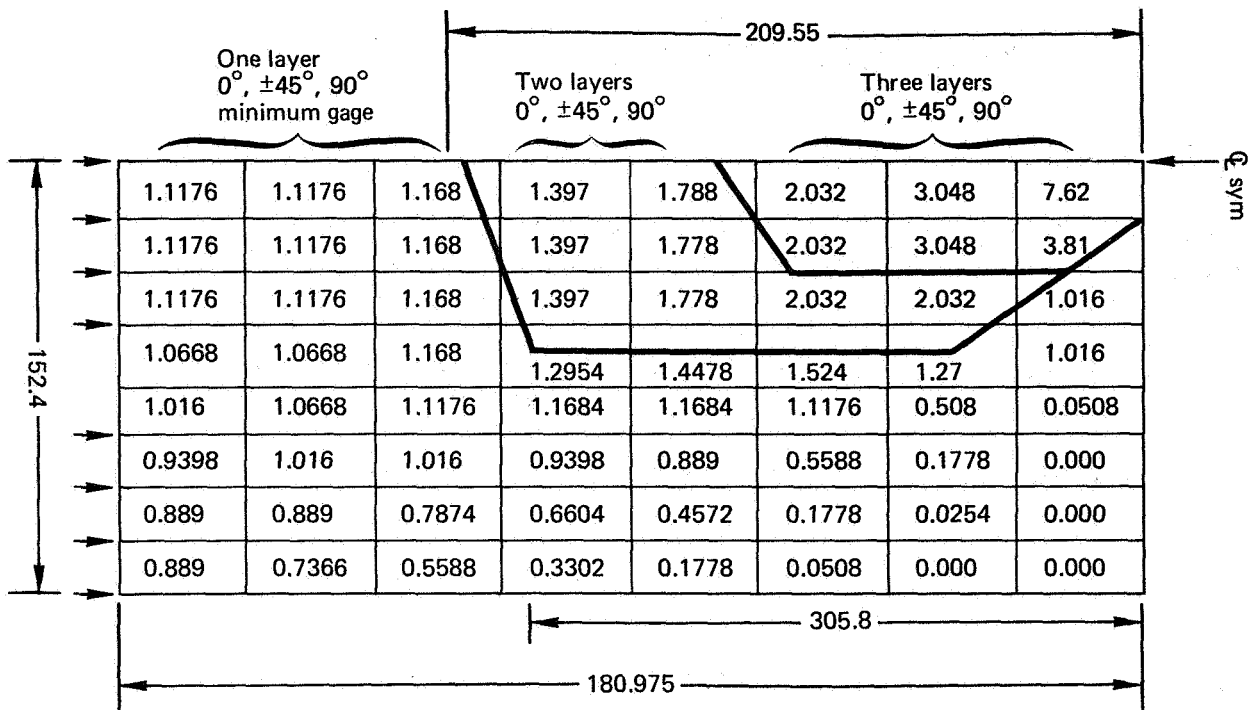

Note: All dimensions are in millimeters

Figure C-1.—Skin Gage Layout, Compression Test Panel

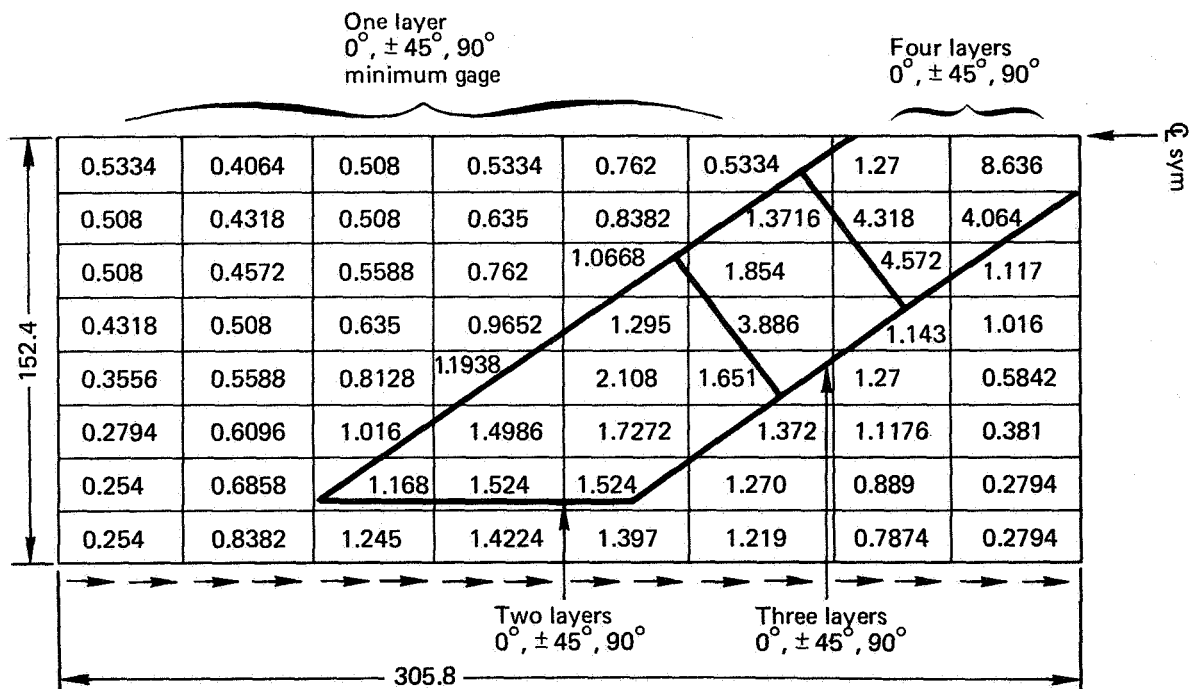

Note: All dimensions are in millimeters.

Figure C-2.—Skin Gage Layout, Shear Test Panel

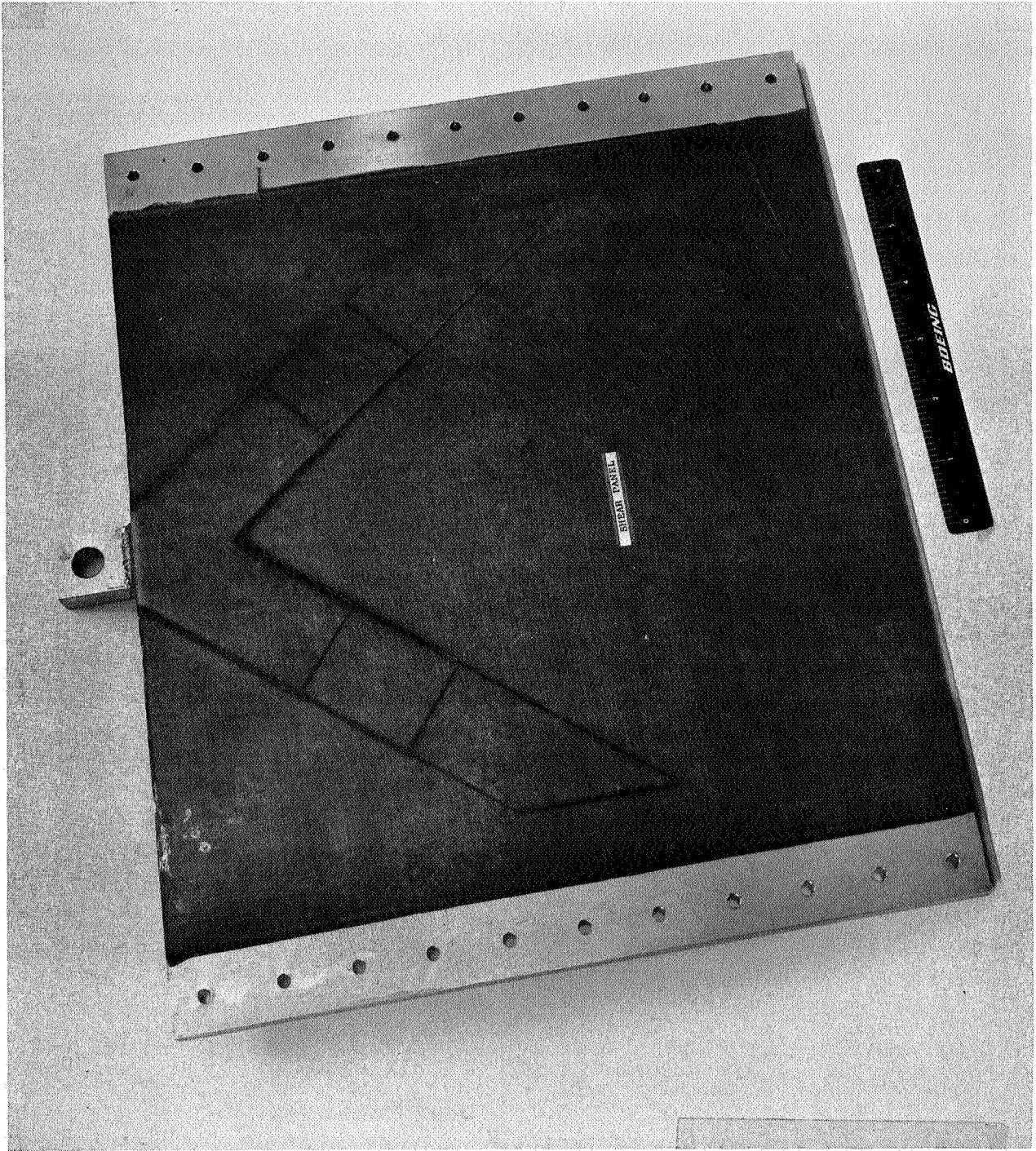

Figure C-3.—Graphite Shear Test Panel

Graphite compression test panel

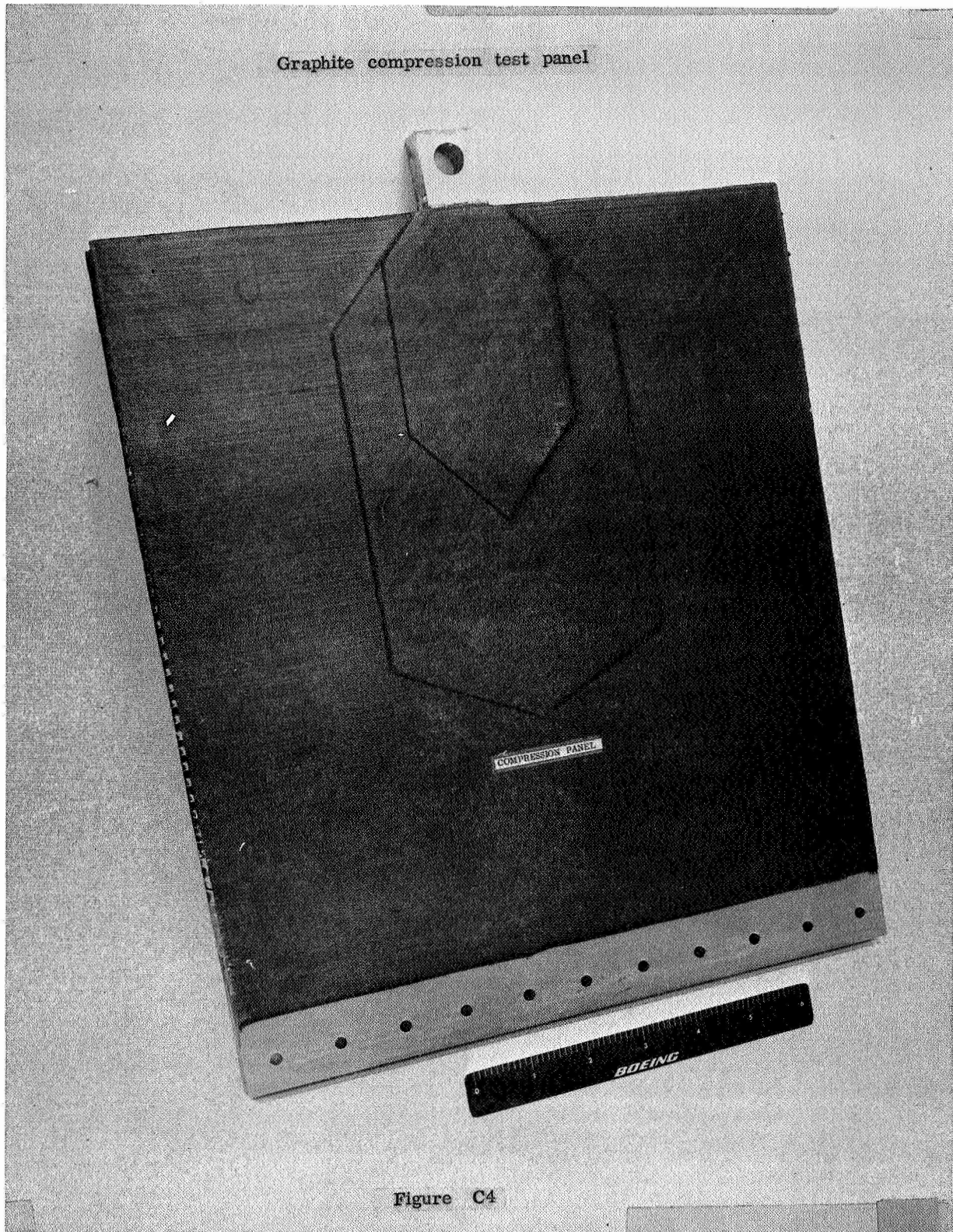
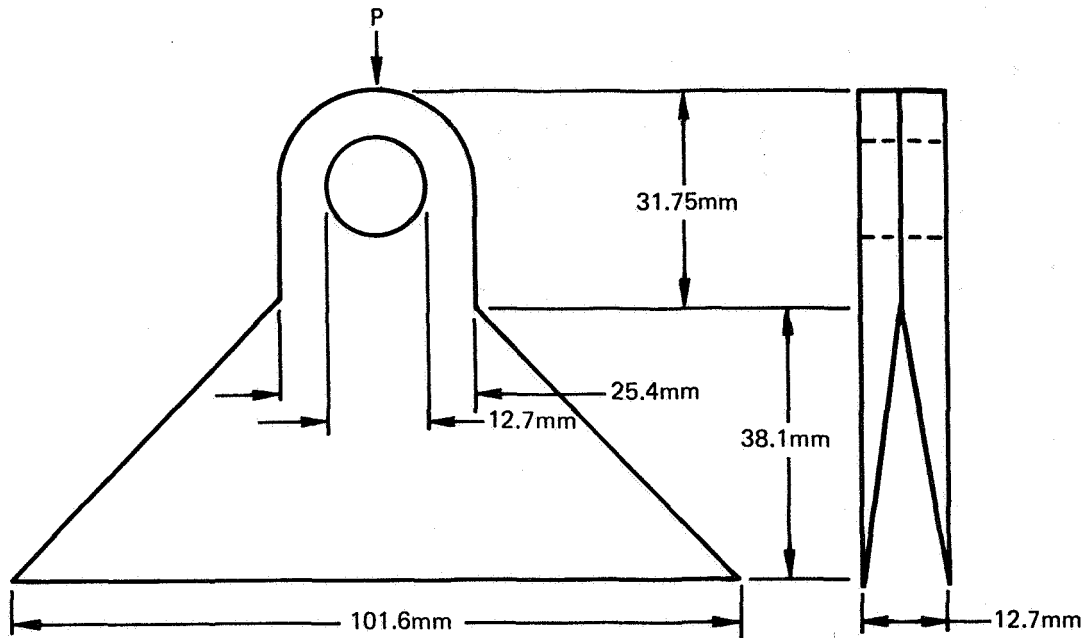

Figure C4

Figure C-4.—Graphite Compression Test Panel

TEST PANEL FITTING CHECK



Total skin to fitting adhesive double shear bond area

$$A = (25.4)(38.1) + (38.1)^2 \cdot 2 = 4838.7 \text{ mm}^2$$

$$P = 112.1 \text{ kN (both shear and compression panels)}$$

Adhesive shear stress

$$f_s = \frac{112.1}{4838.7} = 23.16 \text{ N/mm}^2 = 23.16 \text{ MPa}$$

$$\text{Adhesive } f_s \text{ allowable} = 27.58 \text{ MPa} \text{ Margin of safety} = 0.16$$

Lug bearing stress

$$f_{br} = \frac{112.1}{(12.7)(12.7)} = 695 \text{ N/mm}^2 = 695 \text{ MPa}$$

$$\text{Titanium bearing allowable} = 1351 \text{ MPa} \text{ Margin of safety} = \text{large}$$

COMPRESSION PANEL BUCKLING CHECK

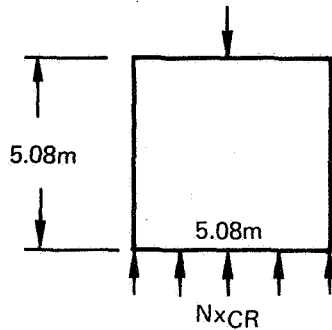

STAGS-B Data Bank
 Aluminum Compression Panel AR = 1.0
 $N_{xCR} = 29.5 \text{ kN/m}$
 $t = 1.02 \text{ mm}$
 $c = 25.4 \text{ mm}$
 $E_{AL} = 71.0 \text{ GPa}$

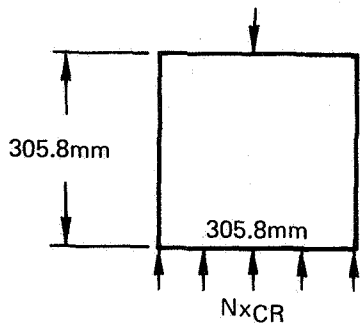

Actual Test Panel
 $t_{min} = 0.508 \text{ mm}$
 $c = 12.7 \text{ mm}$
 $E_{GR} = 45.5 \text{ GPa}$
 $N_x = 368 \text{ kN/m}$

Correcting STAGS-B data bank panel load by ratios of E, h, t_{min} , and c between the two panels.

$$N_{xCR} = (29.5) \left(\frac{45.5}{71.0} \right) \left(\frac{0.508}{1.02} \right) \left(\frac{5080}{305.8} \right)^2 \left(\frac{12.7}{25.4} \right)^2 = 650 \text{ kN/m}$$

Actual applied load = 368 kN/m Margin of safety = large

SHEAR PANEL BUCKLING CHECK

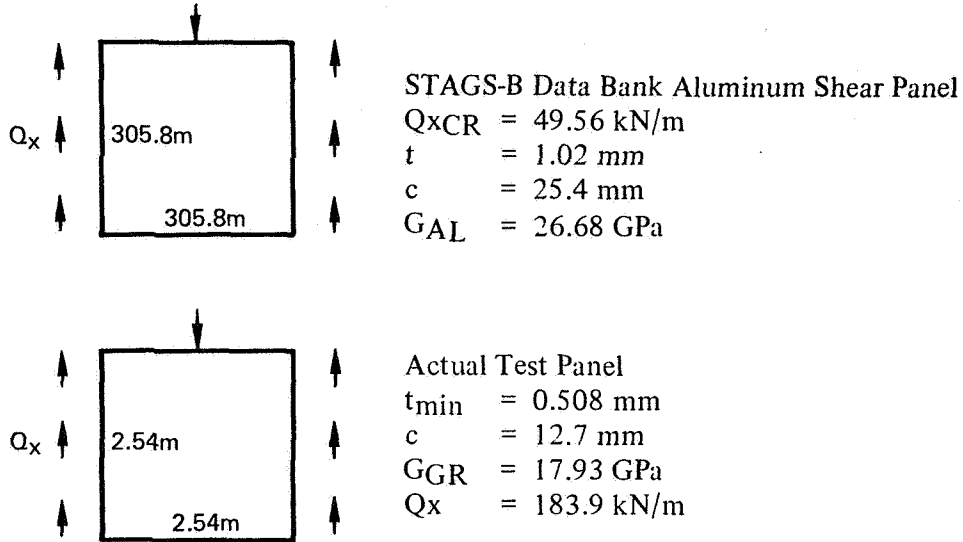

Correcting STAGS-B data bank panel load by ratios of g , h , t_{min} , and c between the two panels.

$$Q_{xCR} = (49.56) \left(\frac{17.92}{26.68} \right) \left(\frac{0.508}{1.02} \right) \left(\frac{2540}{305.8} \right)^2 \left(\frac{12.7}{25.4} \right)^2 = 286 \text{ kN/m}$$

Actual applied load = 183.9 kN/m Margin of safety = large

