

General Disclaimer

One or more of the Following Statements may affect this Document

- This document has been reproduced from the best copy furnished by the organizational source. It is being released in the interest of making available as much information as possible.
- This document may contain data, which exceeds the sheet parameters. It was furnished in this condition by the organizational source and is the best copy available.
- This document may contain tone-on-tone or color graphs, charts and/or pictures, which have been reproduced in black and white.
- This document is paginated as submitted by the original source.
- Portions of this document are not fully legible due to the historical nature of some of the material. However, it is the best reproduction available from the original submission.

JSC-09951

TECHNICAL MEMORANDUM

NASA TM X-58169
January 1976



MOLECULAR CONTAMINATION STUDY BY INTERACTION
OF A MOLECULAR BEAM WITH A PLATINUM SURFACE

(NASA-TM-X-58169) MOLECULAR CONTAMINATION
STUDY BY INTERACTION OF A MOLECULAR BEAM
WITH A PLATINUM SURFACE (NASA) 39 p HC
\$4.00

N76-18894

CSSL 201

Unclas

G3/72 14326

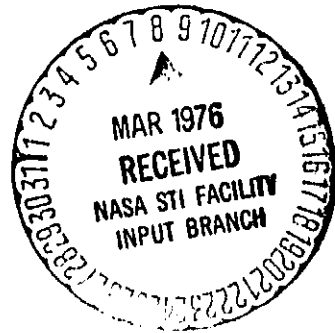

NATIONAL AERONAUTICS AND SPACE ADMINISTRATION

LYNDON B. JOHNSON SPACE CENTER

HOUSTON, TEXAS 77058

1. Report No. MX 58169		2. Government Accession No.		3. Recipient's Catalog No.	
4. Title and Subtitle Molecular Contamination Studies by Interaction of a Molecular Beam With a Platinum surface				5. Report Date January 1976	
				6. Performing Organization Code	
7. Author(s) Hubert E. Nuss				8. Performing Organization Report No. JSC 09951	
9. Performing Organization Name and Address Lyndon B. Johnson Space Center Houston, Texas				10. Work Unit No.	
				11. Contract or Grant No.	
12. Sponsoring Agency Name and Address National Aeronautics and Space Administration Washington, D. C. 20546				13. Type of Report and Period Covered Technical Memorandum	
				14. Sponsoring Agency Code	
15. Supplementary Notes Hubert E. Nuss worked as a European Space Research Organization/National Aeronautics Space And Space Administration (ESRO/NASA) fellow while with the Lyndon B. Johnson Space Center, Houston, Texas 77058.					
16. Abstract An experimental investigation was conducted to study the capability of molecular beam scattering from a solid surface for identification of molecular contamination of the surface. The design and setup of the molecular beam source and the measuring setup for the application of a phase sensitive measuring technique for the determination of the scattered beam intensity are described. The scattering distributions of helium and nitrogen molecular beams interacting with a platinum surface were measured for different amounts of contamination from diffusion pump oil DC 705 (pentaphenyl trimethyl siloxane) for surface temperatures ranging from 30 to 400° C. The results indicate the scattering of molecular beams from a platinum surface is a very sensitive method for detecting surface contamination included by DC 705 pump oil.					
17. Key Words (Suggested by Author(s)) Thin film Contamination Molecular Kinetics Molecular Scattering Molecular Beams			18. Distribution Statement STAR Subject Category 72 (Atomic and Molecular Physics)		
19. Security Classif. (of this report) Unclassified		20. Security Classif. (of this page)		21. No. of Pages 38	22. Price* \$3.75

*For sale by the National Technical Information Service, Springfield, Virginia 22151

NASA - JSC

CONTENTS

Section	Page
SUMMARY	1
INTRODUCTION	1
Theoretical Considerations	2
Experimental Approach	8
Results And Discussion	17
REFERENCES	29

TABLES

Table		Page
I	DEPENDENCE OF AVERAGE RESIDENCE TIME CALCULATIONS FOR DESORPTION ENERGY	5
II	$p_s = 5 \times 10^{-3}$ TORR	12
III	$p_s = 10^{-1}$ TORR	12
IV	$p_s = 10^{-1}$ TORR	13
V	ANGLE OF INCIDENCE AND GEOMETRIC PARAMETERS	14
VI	CALCULATED VALUES FOR $r_s = 115$ mm, $d = 12$ mm $\alpha_1 = 60^\circ$	15
VII	EQUATION CALCULATIONS	16

FIGURES

Figure		Page
1	Plan view of the experimental setup	9
2	Schematic side view of the experimental setup	9
3	Geometric arrangement of scattering experiment	10
4	Geometry of sample holder adapter	10
5	Block diagram of experimental arrangement	11
6	Vapor effusion source chamber	17
7	Primary intensity I_p of the molecular beam as function of angle α^2 with respect to surface normal of beam source with source pressure p_s as parameter	18
8	Primary intensity I_p of the molecular beam as functions of angle α_2 with respect to surface normal of beam source with source pressure p_s as parameters	18
9	Primary intensity $I_p(0)$ of the molecular beam for angle with respect to beam source normal $\alpha_2 = 0$ as a function of source pressure p_s	19

10	Normalized intensity I/I_0 as a function of scattering angle α_3 for an angle of incidence of $\alpha_1 = 60^\circ$ for different temperatures of the platinum surface	20
11	Different scattering distributions for temperatures of the platinum surface T_{pt} in the range up to 110° C and for $T_{pt} = 185^\circ$ C	21
12	Different scattering distribution for temperatures of the platinum surface T_{pt} in the range up to 129° C and for $T_{pt} = 210^\circ$ C	21
13	Intensity for a scattering angle $\alpha_3 = 55^\circ$ as a function of surface temperature T_{pt}	22
14	Scattering distribution for surface temperature up to $T_{pt} = 213^\circ$ C after operation of vapor effusion source VES	23
15	Scattering distribution for surface temperatures up to $T_{pt} = 291^\circ$ C after operation of vapor effusion source VES	23
16	Scattering distributions for an angle of incidence of $\alpha_1 = 55^\circ$ for different temperatures of platinum surface using helium as beam gas after operations of vapor effusion	25
17	Normalized intensity $I(45)/I_c$ for a scattering angle $\alpha_3 = 45^\circ$ as a function of surface temperature T_{pt} after operation of vapor effusion source VES	25
18	Scattering distributions for different surface temperatures T_{pt} for two operations of vapor effusion source	26
19	Scattering distributions for temperature up to $T_{pt} = 400^\circ$ C after two operations of vapor effusion source	27

MOLECULAR CONTAMINATION STUDIES BY INTERACTION OF A
MOLECULAR BEAM WITH A PLATINUM SURFACE

H. E. Nuss,*
Lyndon B. Johnson Space Center

SUMMARY

Optical and thermal control surfaces of spacecraft components have been shown to be particularly sensitive to the effects of contaminant depositions. In this paper the use of molecular beam scattering for contaminant detection is studied. A molecular beam source and phase sensitive measuring setup were designed, built, and installed into a vacuum chamber assembly. Measurements of the primary molecular beam and the scattered beam at a room temperature surface were made to determine the signal-to-noise ratio of the measuring setup. The molecular beam intensity for scattered He and N₂ beams were measured for both a clean platinum (Pt) surface and a surface contaminated from a vapor effusion source by DC 705 (pentaphenyl trimethyl siloxane) in a surface temperature range of 30 to 400° C. Results indicate that molecular beam scattering is an effective method for the detection of contamination. This is done by measuring the change of the scattering distribution at surface temperatures above 200° C from a specularly directed distribution clean surface to an "approximately diffuse" contaminated surface. At surface temperatures of 50° C the scattering distribution is changed by contamination from "approximately diffuse" to a cosine function and from this change the contaminant can be detected. Besides the aspect of contamination detection, the possible applications of molecular beam techniques to other space research applications is mentioned.

INTRODUCTION

Optical and thermal control surfaces of spacecraft components and experiments have been shown to be sensitive to the effects of contaminant deposition (refs. 1, 2, 3, 4). Due to subsequent effects, a critical aspect of organic film contamination with thicknesses of a few hundred Angstroms is the susceptibility of the contaminant to damage by short wavelength ultraviolet or energy ionizing radiation. These processes can cause chemical reactions which result in changes of reflectivity and absorptance/emittance characteristics of the surfaces and the accommodation coefficients for gas surface energy transfer

*Present address: Industrieanlagen-Betriebsgesellschaft mb H (IABG),
8012 Ottobrunn/Munich, West Germany.

(refs. 5, 6, 7). Principal analytical investigations of contamination processes (refs. 8, 9, 10, 11) and studies of degradation effects by various organic films have been conducted for considering the influences during pre-launch testing in space simulation chambers and, also the effects of contamination during missions (refs. 12 through 31). Different conventional measuring methods for the analysis of contamination such as infrared spectroscopy, quartz crystal microbalance gravimetry, ultraviolet reflectance spectroscopy, ellipsometry, and mass spectrometry have been applied; in addition, several novel methods were developed (refs. 32 through 37).

The purpose of this paper is to report the capability of molecular beam interaction with a solid surface for detecting molecular contamination of a surface by an organic film. The measuring principle to be applied is based on the change of the scattering distribution of a molecular beam from a clean surface and from a contaminated surface. The subjects of the studies are:

1. Theoretical considerations concerning the selection of the surface material, surface temperature and beam detector for the molecular beam scattering experiments
2. Design and setup of the beam source for molecular beams of permanent gases, application of a phase sensitive measuring technique and installation of a beam source, sample and beam detector into an existing vacuum chamber assembly (ref. 19)
3. Measurements of the intensity of the primary beam and scattered beam from the surface of a solid at room temperature for determining the sensitivity and signal-to-noise ratio of the measuring setup
4. Scattering distribution measurements at different surface temperatures of a clean solid surface
5. Scattering distribution measurements at different surface temperatures of a solid surface contaminated by a thin organic film
6. Definition of the optimum surface temperature range for detecting a contaminant on the surface by measuring the change of the scattered intensity distribution of the molecular beam from the surface

The investigations were carried out while the author was on a leave from IABG and working as an ESRO/NASA fellow. The support of ESRO is appreciated and the assistance of the Johnson Space Center gratefully acknowledged.

THEORETICAL CONSIDERATIONS

Molecular Beam Scattering from Solid Surfaces

The conceptual picture of the interaction of gas particles with a solid surface as collision of a single gas particle with a coupled lattice of other

particles can be experimentally realized with molecular beam techniques. A molecular beam is characterized by freedom of intermolecular collisions. The process of interaction between gas particle and solid depends on the characteristic properties of the molecular beam and status of the solid, particularly from the conditions at the surface. The capability of detecting thin organic film contamination of a solid surface by a molecular beam scattering experiment is studied.

The principles of molecular beam techniques and experimental and theoretical studies on gas surface interactions have been investigated and reported in a number of papers (refs. 38 through 58). The influence of contamination was measured by a molecular beam scattering (refs. 59 through 64) and accommodation coefficient measurements (refs. 55, 66). Specific aspect for gas-surface interaction for satellite applications was described (refs. 67 and 68). In these papers (refs. 44 through 62), and (refs. 69 through 74) the purpose of the study was to investigate the interaction of a molecular beam with a clean solid surface and contamination of the surface was an undesired effect. For this study, the detection of the contaminant at the solid surface by comparison of the scattering distribution for a clean and contaminated surface is the objective.

The interaction of a gas particle with a solid surface (ref. 46) can be considered to be a two body collision; although, one of the bodies is large and has a complex internal energy structure. Therefore, the interaction process is more complex than between two isolated atoms. From an energy transfer standpoint it may be defined that two extremes in molecule surface collision phenomena are: completely elastic scattering (no internal energy change in either the gas molecule or the lattice); and, trapping (permanent adsorption and complete energy accommodation). Between these limiting conditions as the trapping condition is approached, the re-emission that occurs tends to become more diffuse. However, cosine scattering need not be associated with an accommodation coefficient of unity. For elastic collisions the accommodation coefficient for translational energy transfer need not vanish. However by definition, the accommodation coefficient (AC) for internal energy transfer (rotation, vibration, phonon excitation) must be zero. In the range $0 < AC < 1$ directed scattering as result of the gas surface interaction is encountered.

Based upon the spatial behavior of the scattered beam (refs. 44 through 62 and 69 through 74) the results of molecular beam scattering from a solid surface may be divided into three categories: diffraction; diffuse scattering; and, directed scattering. For diffraction a necessary but not sufficient condition is a fully elastic collision between a gas atom and a lattice, which results in zero energy transfer to the lattice (refs. 38 and 46). The geometrical criteria for the observation of diffraction are the proper relationship between the de Broglie wavelength of the molecular beam, lattice spacing, and angle of incidence (refs. 38). The effect of surface contamination on the geometrical aspects of diffraction is minimal (refs. 46, 70, 71). Diffuse scattering is characterized by the intensity of the scattered beam varying as the cosine of the angle between the direction of observation and the target normal. Any process where the particle spends a significant time in interaction with the surface relative to a single elastic collision may lead to diffuse scattering. Although the spatial randomization is complete in diffuse scattering, energy

accommodation need not be (ref. 72). Diffuse scattering is usually associated with microscopically rough surfaces or grossly contaminated surfaces (ref. 46). Directed scattering or lobular scattering of molecular beams from solid surfaces is the result of the complex dynamical interaction of the gas-solid system when a free molecule collides with a crystalline lattice. The spatial distribution of the scattered beam is not generally describable in terms of superposition of diffuse scattering and specular reflection or diffraction. In this context specular reflection is to be distinguished from specularly directed reflection. The latter implies that the angular divergence of the scattered beam is much greater than that of the incident beam. Consequently, directed scattering is a function of the parameters of the system that are related to the interaction potential and lattice dynamics (ref. 46).

Influence of Contamination on Molecular Beam Scattering from Solid Surfaces

Using epitaxially grown Au films the sensitivity of scattering distributions to the conditions of the target surface in terms of surface structure and contamination has been demonstrated (ref. 63). These studies indicate the sensitive change of the scattering distributions, due to contamination of the surface by the ambient vacuum background approximately equal to 10^{-7} torr. Other investigations (refs. 60 through 62, 64) of metal surface systems show that at ambient pressures of 10^{-7} torr a temperature exists below which the surface exhibits diffuse scattering. This is a reversible transition and surface temperature is approximately 200° C. The most reasonable explanation is a contaminant adsorption because only in scattering measurements under UHV conditions has this effect not been found (refs. 46, 64). A concurrent low energy electron diffraction (LEED) and molecular beam scattering study under UHV conditions shows the sharpness of the scattering peak was a more sensitive measure of CO and C_2H_4 contamination than the quality of the LEED pattern (ref. 59).

Specularly directed scattering has been observed on clean, contaminated, single and polycrystalline surfaces. The sensitivity of directed scattering to contamination of the surface considering the details of the scattering distribution has been shown (refs. 59, 63). It was decided to use a platinum surface for the present investigation as a conclusion of the reported results (refs. 59, 60, 62, 63, 64). The basic idea of molecular beam scattering for the detection of contamination of the platinum by organic molecules can be described by the following conceptual picture. For a specific surface temperature the adsorbed particles of permanent gases of the vacuum background can be removed. The scattering distribution can be measured to be specularly directed. Because of a higher desorption energy at this surface temperature the organic molecules can not be removed. A change of the scattering distribution can be attributed to the organic contamination. The amount of contamination adsorbed on the surface is dependent on the residence time τ_r of contaminant molecules (refs. 64, 75).

$$\tau_r = \tau_0 \exp (\Delta E/RT) \quad (1)$$

where τ_0 : vibrational period of the lattice, seconds

ΔE : desorption activation energy

R: gas constant

and T: absolute temperature

For the amount of adsorbed molecules S_r remaining on a flat metal surface the following relationship holds:

$$S_r = S_o \exp \left(-\frac{t}{\tau_r} \right) \quad (2)$$

where S_o : number of molecules adsorbed on the surface at time $t=0$

S_r : number of molecules remaining after time t

τ_r : average residence time

and t : time of outgassing

Equations 1 and 2 show that the amount of adsorbed gases depends on the values of the desorption activation energy and surface temperature. The desorption energy for helium from platinum is 0.2 Kcal/mole (ref. 76). The desorption energies for oils are in the range of 25 Kcal/mole (ref. 64) and higher. The sensitive dependence of the average residence time τ_r calculated according to equation 1 from the desorption energy ΔE is shown in Table I for a surface temperature of 300° K and $\tau_o = 10^{-13}$ sec for two different values of desorption energies.

TABLE I.- DEPENDENCE OF AVERAGE RESIDENCE TIME
CALCULATIONS FOR DESORPTION ENERGY

<u>ΔE, Kcal</u> <u>Mole</u>	<u>τ_r, Sec</u>
0.2	1.4×10^{-13}
30	7.2×10^8

Formation of Molecular Beams

The production of molecular beams characterized by almost complete freedom from intermolecular collisions is possible by producing a certain vapor pressure in an enclosure with a well defined exit opening into a vacuum chamber.

For molecular flow conditions (mean free path of the particles is much greater than dimensions of aperture) the number of particles $dN(\theta)$ per second effusing from an enclosure with an ideal aperture of area A_S into the solid angle $d\omega$ at an angle θ with respect to the normal to A_S is (refs. 38, 39, 41) given by the expression:

$$dN(\theta) = \frac{n_s v_a A_S}{4\pi} \cos \theta d\omega \quad (3)$$

n_s : number of particles per unit volume in enclosure

v_a : mean molecular velocity

By integration the total number N of particles per second escaping through the aperture is:

$$N = \frac{n_s v_a A_S}{4} \quad (4)$$

From equation (3) the number of particles per second in the forward direction ($\theta=0$) can be derived:

$$N(0) = \frac{n_s v_a A_S}{4\pi} \quad (5)$$

From kinetic gas theory n_s and v_a are defined:

$$n_s = \frac{p_s}{kT_s} \text{ and } v_a = \frac{8kT_s}{6m} \quad (6)$$

where

p_s : pressure in enclosure

T_s : temperature in enclosure

m : mass of particle

k : Boltzmann constant

and therefore for the total number of particles per second(s) from equation 4 follows:

$$N = \frac{P_s A_s}{(2mmkT_s)^{1/2}} = 3.51 \times 10^{-2} \frac{P_s A_s}{(MT_s)^{1/2}} \quad \frac{\text{molecules}}{\text{sec}} \quad (7)$$

M: molecular weight

According to equations 3 and 7 the number of particles per second striking a target of unit area on the axis of the aperture ($\theta=0$) at a distance r from the aperture is:

$$I(0) = \frac{n_s v_s A_s}{4\pi r^2} = 1.11 \times 10^{22} \frac{P_s A_s}{r^2 (MT_s)^{1/2}} \text{ molecules/cm}^2 \text{ sec} \quad (8)$$

If the pumping of scattered molecules is not a problem the maximum rate of effusion from an ideal aperture is reached when the mean free path of the particles is slightly less than the dimensions of the aperture (refs. 38, 39, 41). Considering instead of an ideal aperture, a cylindrical channel of length l and radius a , equation 5 is still valid. However, the total number of particles per second is reduced by the Clausing factor (ref. 77) to N_1 :

$$N_1 = \frac{8a}{3l} \cdot \frac{n_s v_s A_s}{4} \quad (9)$$

As the pressure is increased to where the mean free path is no longer large compared to the length of the tube ($\lambda > a, \lambda < l$) equation 9 is still valid for the total number of particles per second but the number of particles per second in the forward direction is (ref. 78):

$$N_1(0) = \frac{2^{1/2} A_s v_s n_s^{1/2}}{8\pi \delta l^{1/2}} \quad (10)$$

δ : molecular diameter

From equation (5) and (10)

$$\frac{N(0)}{N_1(0)} = 2^{3/4} \delta l^{1/2} n_s^{1/2} \quad (11)$$

EXPERIMENTAL APPROACH

The studies were conducted in a work chamber assembly (WCA) where different methods of contamination analysis such as vacuum-ultraviolet-reflectance spectrometry, ellipsometry and residual gas mass spectrometry can be applied (ref. 19). This WCA where a vapor effusion source (VES) is attached for the deposition of molecular contamination films was furnished with the molecular beam source, sample holder adapter and heater, and molecular beam detector and phase sensitive measuring setup (figs. 1, 2, 3, 4, and 5).

For a collimated beam of particles drawn from a molecular beam source and taken far enough away for an experiment conveniently to be conducted, the density in the beam is in the order of magnitude 10^9 particles/cm³. This must be compared to a density of particles in the residual gas in the chamber, which is approximately 4×10^{10} particles/cm³ of a pressure of $p = 10^{-6}$ torr. Because of the slow fluctuations and drifts in pressure in ordinary vacuum systems it is obvious that looking for a signal of 1 part in 40 with dc techniques promises little but difficulty. Therefore an ac experiment is suggested (refs. 79 through 83). If the molecular beam is modulated by a mechanical chopper, the desired signal can be identified by its specific frequency and phase. The signal arising from the background gas will be a dc signal plus a certain amount of noise at the modulation frequency. As long as the period of chopping of the molecular beam is very small compared with the time constant of the vacuum system, the amplitude of the background gas density oscillations will be small compared with the density changes in the beam. Because the background pressure fluctuation is proportional to the background pressure, a differentially pumped system is recommended for increasing the signal-to-noise ratio. The pressure in the main chamber during the scattering measurements was in the range of 7×10^{-7} to 8×10^{-6} torr.

Molecular Beam Source

The molecular beam arrangement designed and built for the scattering experiments consists of the beam source tube of 12 mm diameter and 1035 mm length, collimating tube of 82 mm diameter and 325 mm length, and a 102 mm tube diameter T-piece that connects beam source tube, collimating tube, work chamber assembly and pumping station for the beam source.

The optimum orifice geometry for the delivery of the maximum fractions of effusing molecules on to a target was a long cylindrical aperture (ref. 84). The dimensions of the aperture in the beam source were 1 mm diameter, 12 mm long, the aperture in the collimating tube had a 1 mm diameter and was 5 mm long. An oil diffusion pump system with a liquid nitrogen cooled cold trap and an optically dense water cooled baffle (nominal pumping speed of diffusion pump 400 l/s) served as the pumping system for the beam source. The beam source tube was attached to a manifold with a variable needle valve, gas reservoir and thermocouple gage. This manifold was pumped down to a pressure of

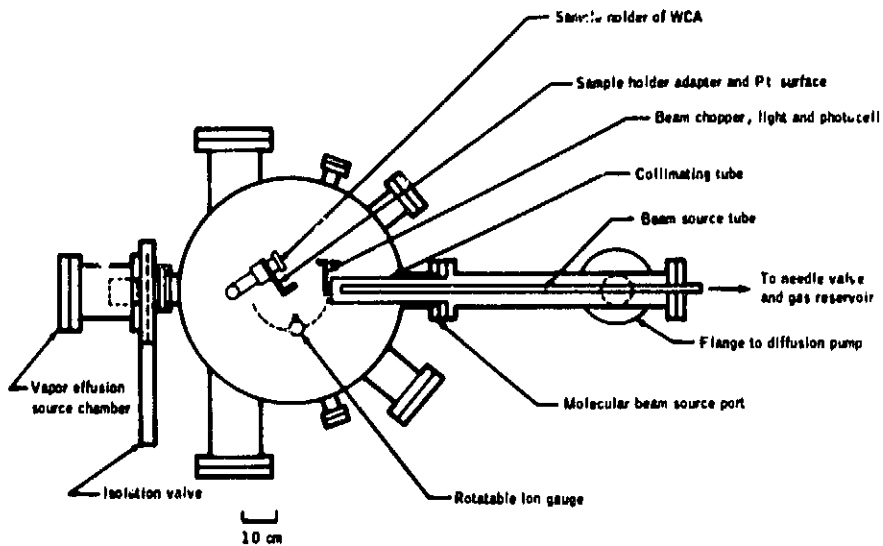

Figure 1.- Plan view of the experimental setup.

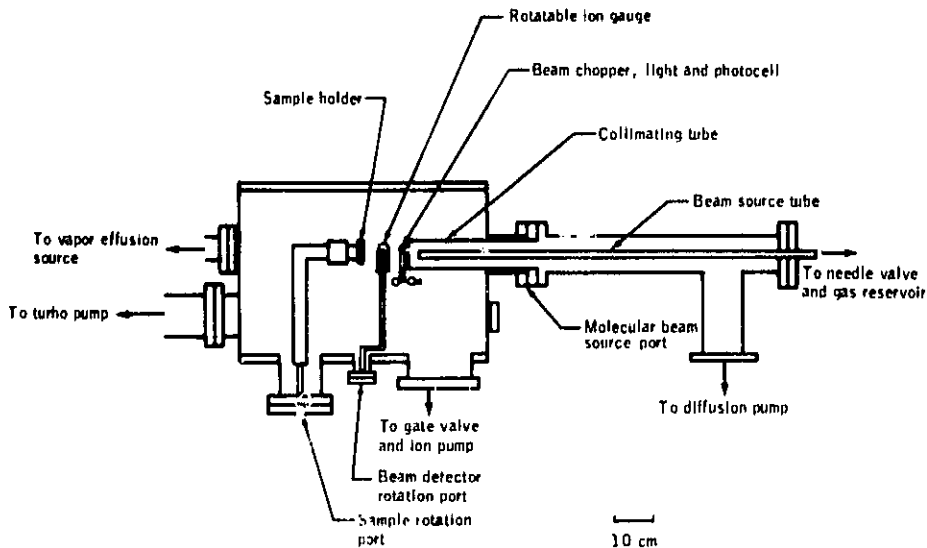

Figure 2.- Schematic elevation view of the experimental setup.

REPRODUCIBILITY OF THE
ORIGINAL PRICE IS FOUR

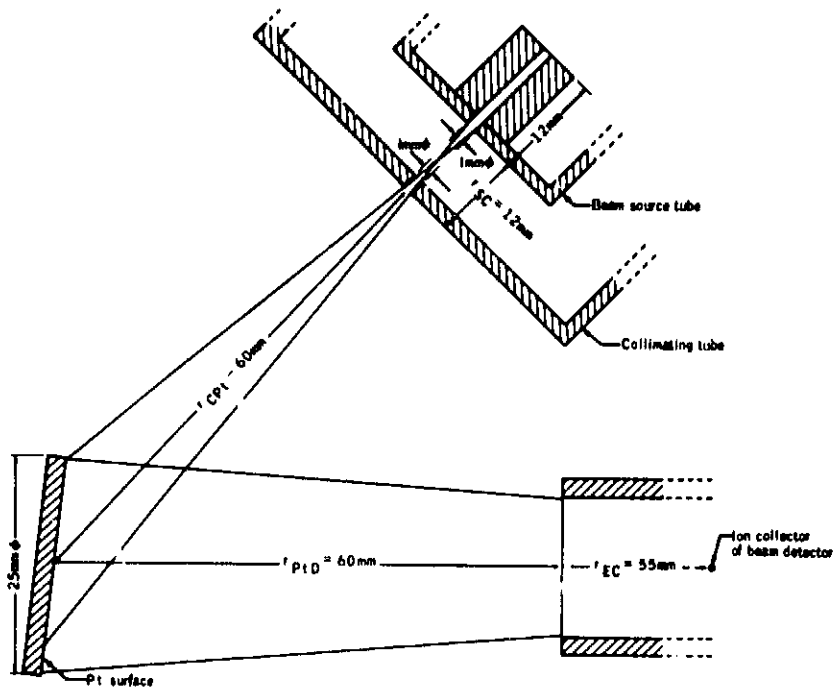

Figure 3.- Geometric arrangement of scattering experiment.

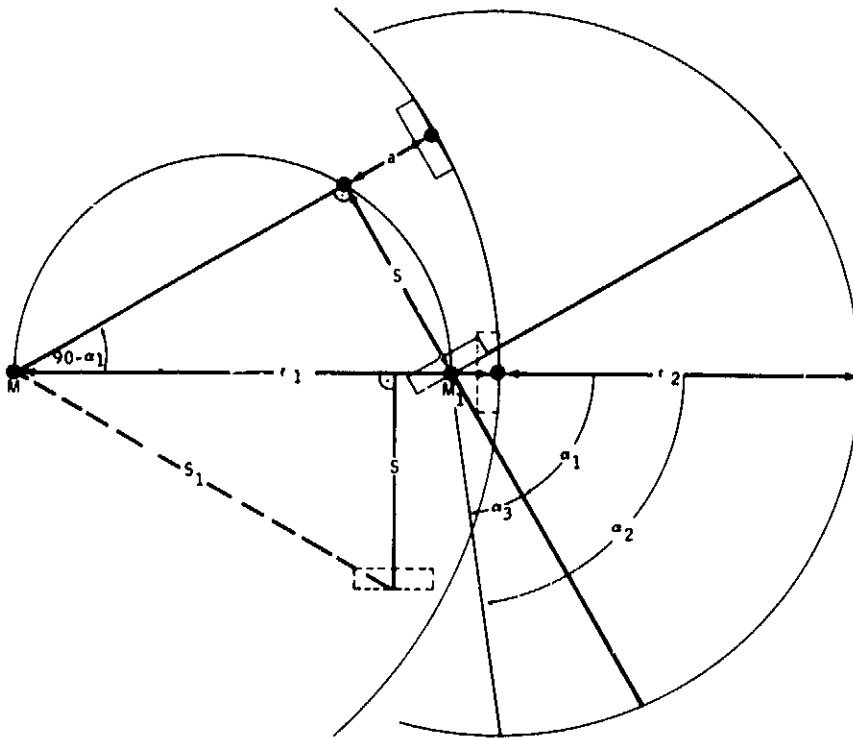

Figure 4.- Geometry of sample holder adapter.

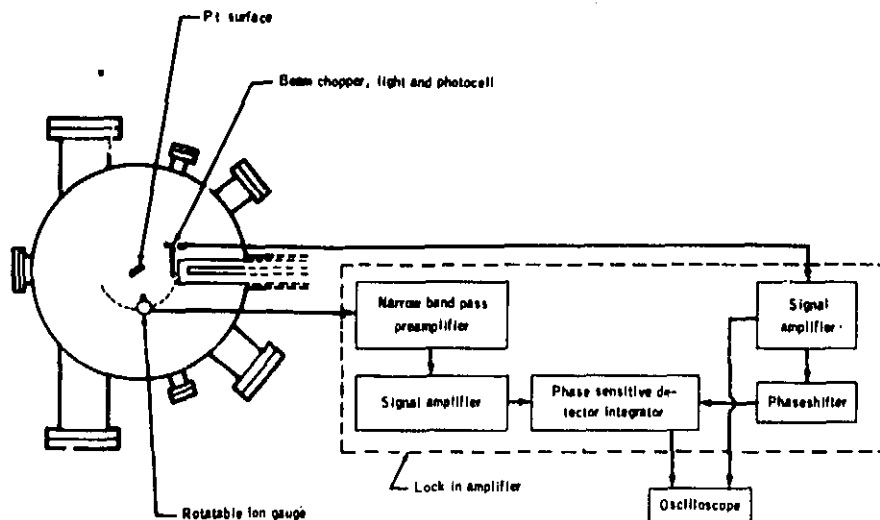

Figure 5.- Block diagram of experimental arrangement.

10^{-2} torr by a forepump supplemented with a liquid nitrogen cooled cold trap before the diffusion pump system for the beam source could be used. (For the number of molecules effusing from the beam source see section entitled Formation of Molecular Beams).

In Tables II and III some characteristic parameters for gases at room temperature conditions are exhibited.

n_B, p_B : number density and pressure, respectively, in the molecular beam for $\theta=0$

$I_1(0)$: intensity for $\theta=0$ for conditions characterized by $\lambda > a, \lambda < 1$

For the calculations in Table II the conditions $\lambda > a, \lambda > 1$ are fulfilled and $I(0)$ calculated according to equation 8, n_B with the aid of the relationship $n_B = I(0)/v_a$ and p_B according to equation 6.

The values of Table III were calculated from equation 8 and 10 and using the relationship

$$I_1(0) = \frac{I(0) N_1(0)}{N(0)} \quad (12)$$

$$\text{with } \frac{N(0)}{N_1(0)} = 2.2 \text{ for He} \quad (13)$$

$$\text{and } \frac{N(0)}{N_1(0)} = 3.8 \text{ for } N_2 \quad (14)$$

TABLE II.- $p_s = 5 \times 10^{-3}$ TORR

Gas	λ , mm	$I(\omega)$, $\frac{\text{molecules}}{\text{cm}^2 \cdot \text{S}}$	$n_{\beta'}$, $\frac{\text{molecules}}{\text{cm}^3}$	p_{β} torr
He	30	4.1×10^{13}	3.7×10^8	1.1×10^{-8}
N ₂	10	1.4×10^{13}	3.5×10^8	1.1×10^{-8}

TABLE III.- $p_s = 10^{-1}$ TORR

Gas	λ , mm	$I_1(\omega)$, $\frac{\text{molecules}}{\text{cm}^2 \cdot \text{S}}$	$n_{\beta'}$, $\frac{\text{molecules}}{\text{cm}^3}$	p_{β} torr
He	1.5	3.7×10^{14}	3.3×10^9	9.8×10^{-8}
N ₂	0.5	7.6×10^{13}	1.9×10^9	6.0×10^{-8}

From the values in Table IV, vacuum conditions in the intermediate and main chamber as a function of the pressure in the beam source could be estimated.

Phase Sensitive Measuring Setup (fig. 5)

A mechanical beam chopper with 18 slots (outer diameter of chopper wheel is 70 mm and slot height is 12 mm) driven by a synchronous motor of 150 RPM chopped the molecular beam. A phase lock amplifier could separate the beam signal from the background signal. The modulator also chopped a light beam received by a CdSe photoconductive cell. This signal serves as a reference signal to the lockin amplifier. The chopping frequency of the molecular beam is 45 s^{-1} , which corresponded to a time constant of $2.2 \times 10^{-2} \text{ s}$, while the time constant of the photocell was $2.1 \times 10^{-2} \text{ s}$. Volume of the vacuum chamber is 120 liters and the effective pumping speed of the ion pump was assumed to be 120 l s^{-1} . The time constant for the vacuum system of 1 second was estimated. Therefore the condition that the chopping period of the molecular beam is small compared to the time constant of the vacuum system is fulfilled.

TABLE IV. $p_s = 10^{-1}$ TORR

Gas	N_1 (o), <u>molecules</u> <u>S</u>	N_1 , <u>molecules</u> <u>S</u>
He	1×10^{17}	1.5×10^{17}
N ₂	2×10^{16}	5.4×10^{16}

Scattering Surface

The sample which the scattering experiments were conducted on was a platinum surface produced by sputtering. The substrate was a quartz sample (25 mm diameter, 6 mm thick). The thickness of the platinum film was $1200 \text{ \AA} \pm 200 \text{ \AA}$. The Pt film stripped from the silica has been examined in the transmission electron microscope. The film was too thick for observation except at the edges of several small holes. These were examined with the result that the crystallite size is approximately 100 \AA . The diffraction patterns indicate a random dispersion of orientations from which it is concluded that there was no texture in the foil. A Nichrome wire heated the sample by radiation to 400° C . The temperature of the surface was measured with a thermocouple connected to the platinum surface. Because the standard sample holder for the vacuum chamber

directed that the sample surface be vertical to the beam axis, this sample holder could not be used. A sample holder adapter (fig. 4) was designed and built. On fig. 4 the geometric arrangement of the Pt sample, sample holder adapter and WCA sample holder are shown for two positions of the rotatable sample holder.

From fig. 4 the following relationships can be derived:

$$s = \left(r_1 - \frac{d}{\sin \alpha_1} \right) \cos \alpha_1 \quad (15)$$

$$a = r_1 (1 - \sin \alpha_1) + d \quad (16)$$

For different angle of incidence α_1 , in Table V, the geometric parameters s and a were calculated with $r_1 = 150$ mm and $d = 12$ mm.

The angle of incidence α_1 for the molecular beam can be varied by adjusting s and a to the specific values of Table V. Using a laser beam, by which the source tube and collimating tube aperture were aligned, the angle of specular reflectance may be determined. The effects of the sample holder adapter, the Pt sample surface could not be adjusted exactly to the rotation axis of the molecular beam detector, will be estimated.

TABLE V.- ANGLE OF INCIDENCE AND GEOMETRIC PARAMETERS

<u>α_1, deg</u>	<u>S, mm</u>	<u>a, mm</u>
75	35.7	18.0
70	46.6	22.5
65	57.5	25.5
60	68.1	31.5

Because the rotation axis of the molecular beam detector is in the sample surface of the work chamber assembly sample holder and not on the platinum sample surface of the sample holder adapter the distance of the beam deflector from the center of the Pt sample r_3 varies as a function of scattering angle

α_3 . If r_2 is the distance of the beam detector from the rotation axis, for the distance r_3 of the molecular beam detector from the Pt sample the following relationship can be derived according to fig. 4.

$$r_3 = r_2 + \frac{d \cos (\alpha_1 + \alpha_3)}{\sin \alpha_1} \quad (17)$$

Table VI shows calculated values for $r_2 = 115$ mm, $d = 12$ mm $\alpha_1 = 60^\circ$.

The values of Table VI indicate that with increasing scattering angle the distance beam detector to scattering surface is decreasing. Because the angle measuring scale is attached to the rotation axis of the sample surface of the WCA sample holder the measured angle α_3 also differs from the scattering angle with respect to the shifted Pt surface. For the real scattering angle α_{3r} the following relationship can be derived from fig. 4:

$$\cos \alpha_{3r} = \frac{r_2^2 + r_3^2 - (2r_2 \sin \frac{\alpha_3}{2})^2}{2r_2 r_3} \quad (18)$$

TABLE VI.- CALCULATED VALUES FOR $r_2 = 115$ mm, $d = 12$ mm $\alpha_1 = 60^\circ$

<u>α_3, deg</u>	<u>r_3, mm</u>
- 0	122.9
- 20	117.4
- 30	115.0
- 60	107.1
- 80	104.4
- 90	103.0

In Table VII the angle α_{3r} was calculated according to equation (17) and (18) for $r_2 = 115$ mm, $d = 12$ mm, $\alpha_1 = 60^\circ$:

If absolute values of scattered intensities are to be measured the results of Tables VI and VII have to be taken into consideration. For a scattering angle of $\alpha_3 = 60^\circ$ the measured intensity due to the displacement of the Pt sample is approximately 15 percent higher than would be for a constant distance from rotation axis if a relationship $I \sim 1/r^2$ is assumed. Because for this paper relative measurements comparing a clean and a contaminated surface are the main objectives, the changes of r_3 and α_{3r} have not been considered.

TABLE VII.- EQUATION CALCULATIONS

<u>α_3, deg</u>	<u>α_{3r}, deg</u>
- 0	0
- 20	18
- 30	29
- 60	62
- 80	84
- 90	96

Vapor Effusion Source (VES) (fig. 6) (ref. 19)

The vapor effusion source for deposition of high molecular weight organic contaminant films on to a surface is in an annex to the main chamber of the work chamber assembly. A combination of three apertures (a beam skimmer and two liquid-nitrogen cooled collimators). limit the cross section of the molecular beam to the diameter of the sample. The beam source has a single orifice nozzle. For measurements the source was filled with DC 705 pentaphenyl trimethyl siloxane diffusion pump oil. The vapor pressure in the source can be changed by variation of the source temperature.

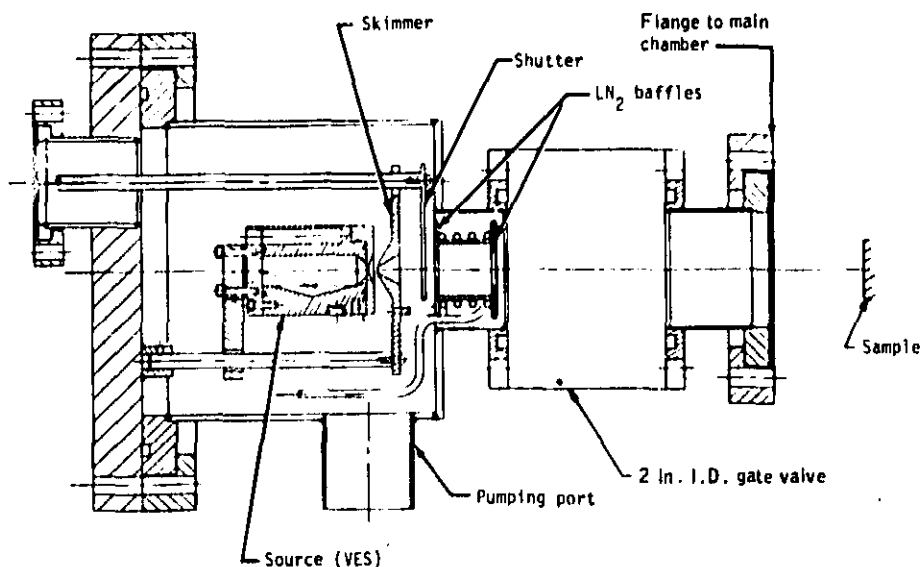

Figure 6.- Vapor effusion source chamber.

RESULTS AND DISCUSSION

Primary Molecular Beams

The angular distribution measurements of the primary beam were made to determine the intensity dependence from the pressure in the beam source, p_s , for: (1) signal-to-noise ratio measurements; (2) checking the angular resolution of the molecular beam detector (ion gage with entrance of 17 mm diam); and, (3) measurement of the vacuum conditions in the main and intermediate chambers. The distance of the collector of the ion gage to the aperture of the beam source was 220 mm. Distance of the ion gage collector from the entrance slit was 83 mm.

On figs. 7 and 8 the primary intensity is plotted of a He molecular beam as a function of angle α_2 with respect to surface normal of the beam source. The distributions show the directivity of the source caused by the long cylindrical channels used as beam source and collimating apertures. Figure 9 shows the dependence of the primary intensity for $\alpha_2 = 0$, $I_p(0)$ as a function of source pressure, p_s . The result of fig. 9 shows that the intensity $I_p(0)$ is not a linear function of source pressure, p_s , as proposed by equation 8 but is approximately proportional to $p_s^{1/2}$, (equation 10). The pressure in the main chamber was 5×10^{-6} torr smaller for source pressures up to 1000 μ . The pressure increase due to the scattered beam particles was less than the values predicted in Table IV.

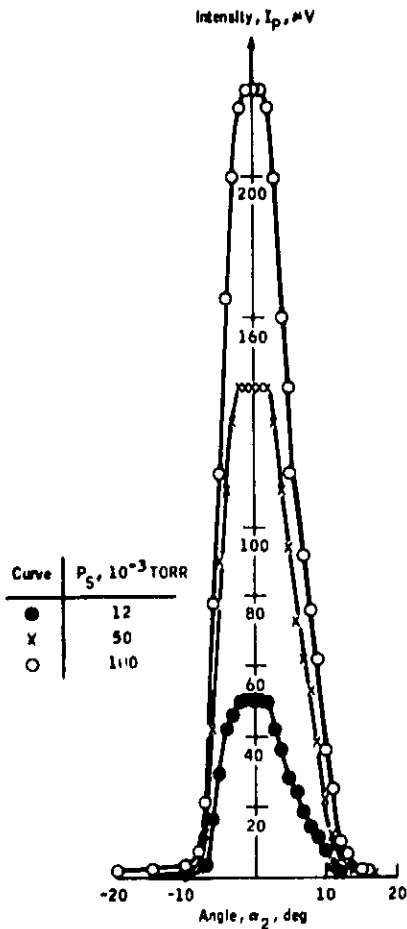

Figure 7.- Primary intensity I_p of the molecular beam as function of angle α_2 with respect to surface normal of beam source with source pressure p_s as parameter.

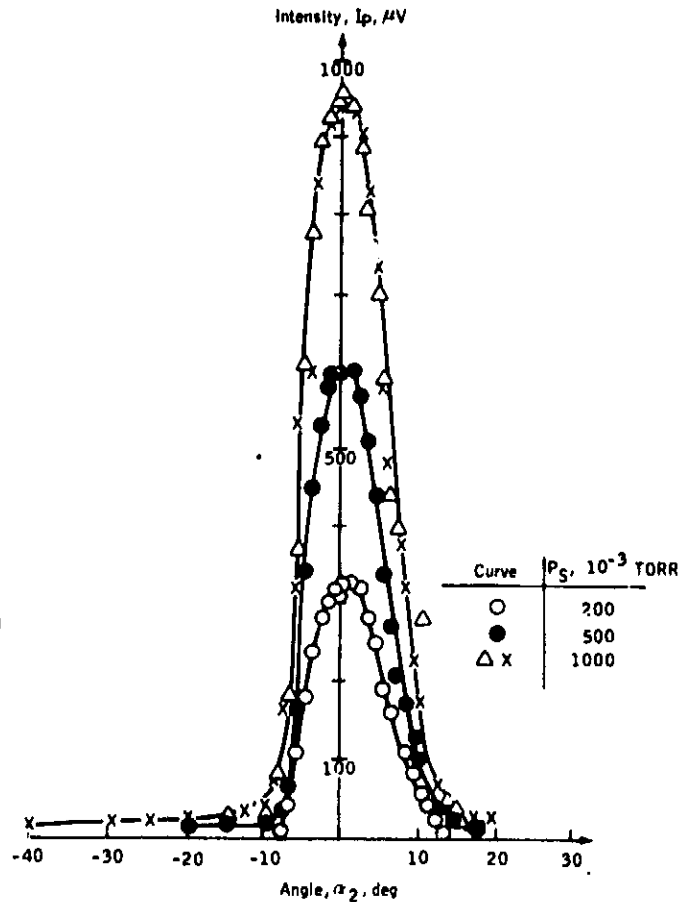

Figure 8.- Primary intensity I_p of the molecular beam as functions of angle α_2 with respect to surface normal of beam source with source pressure p_s as parameters.

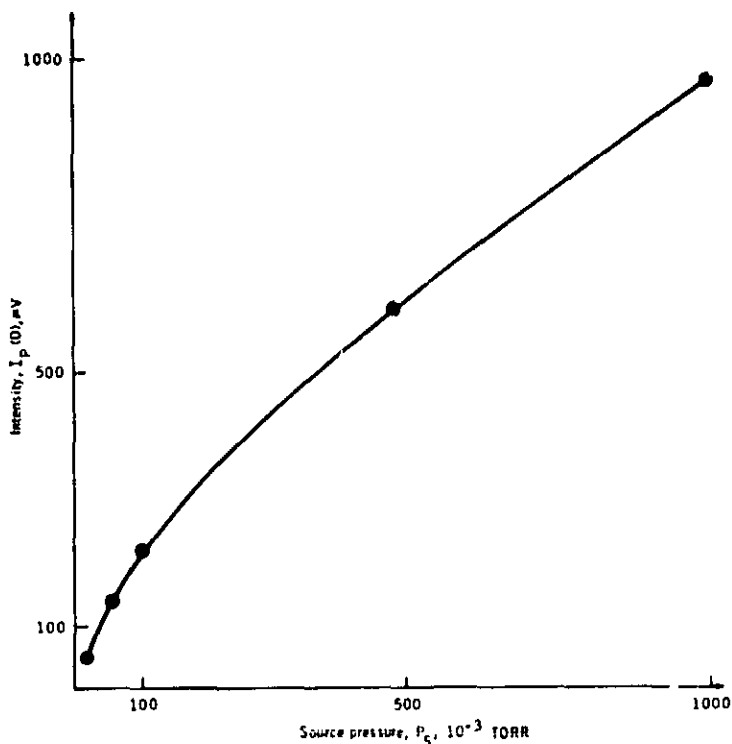

Figure 9.- Primary intensity $I_p(0)$ of the molecular beam for angle with respect to beam source normal $\alpha_2 = 0$ as a function of source pressure p_s .

Scattered Molecular Beam From a Platinum Surface

For the first scattering measurements (because of the low pumping speed of the ion pump of the main chamber for He gas) the beam gas was changed to nitrogen. The distance of Pt sample to aperture of beam source was 60 mm; distance from sample surface to ion gage collector 115 mm; and, distance of entrance slit of ion gage (17 mm ϕ) to ion gage collector 55 mm.

On figs. 10 and 11 the normalized scattered intensity I/I_0 (I_0 refers to the intensity for $\alpha_3 = 0$) as a function of scattering angle α_3 is shown. In the surface temperature range of 39 to 110 $^\circ$ C the measured scattering distribution is "approximately diffuse." There is a deviation from the complete diffuse distribution (fig. 11) for the cosine function. The measured deviation from the cosine law can partially be caused by the changing distance of ion gage detector from scattering surface according to Table VI because for $\alpha_3 = 60$ and $\alpha_3 = 80^\circ$ the measured intensities according to these effects have to be decreased by 15 or 20 percent, respectively. Figure 11 shows that after a possible correction there is still a higher intensity measured than what the cosine function would yield. The measured intensity distribution is called

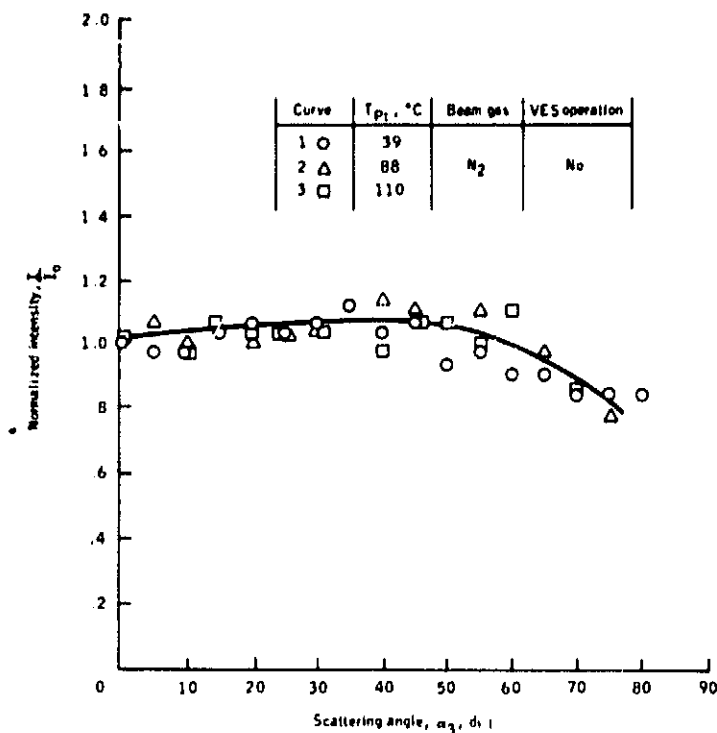

Figure 10.- Normalized intensity I/I_0 as a function of scattering angle α_3 for an angle of incidence of $\alpha_1 = 60^\circ$ for different temperatures of the platinum surface.

"approximately diffuse." However a specularly directed component appears to distinguish these distributions from the specularly directed distribution shown on fig. 11 for a surface temperature of 185°C . On fig. 12 the reproducibility of the measurements is indicated. The results of figs. 10, 11, and 12 are in agreement with other investigations (refs. 60, 61, 62, 64). The reversible transition between diffuse and specularly directed scattering at a surface temperature of approximately 200°C is explained by removal of adsorbed layers because of the background pressure (refs. 46, 74). Curve No. 4 of fig. 11 and 7 of fig. 12 displays that for an angle of incidence $\alpha_1 = 62^\circ$ the maximum specularly directed scattered intensity is measured for a scattering angle of $\alpha_3 = 52^\circ$. This subspecular scattering agrees with results of other studies of molecular beam scattering (refs. 60, 73, 74). On fig. 13 the scattered beam intensity is plotted for a scattering angle $\alpha_3 = 55^\circ$ as a function of surface temperature. Intensity $I(55)$ starts to increase at an approximate temperature of 160°C and increases in the entire measured temperature range up to 210°C . The result is in agreement with other investigations scattering He beams on platinum (60). For these studies the intensity reaches a saturation value at approximately 200 to 800°C , which could not be identified because of the limited surface temperature range.

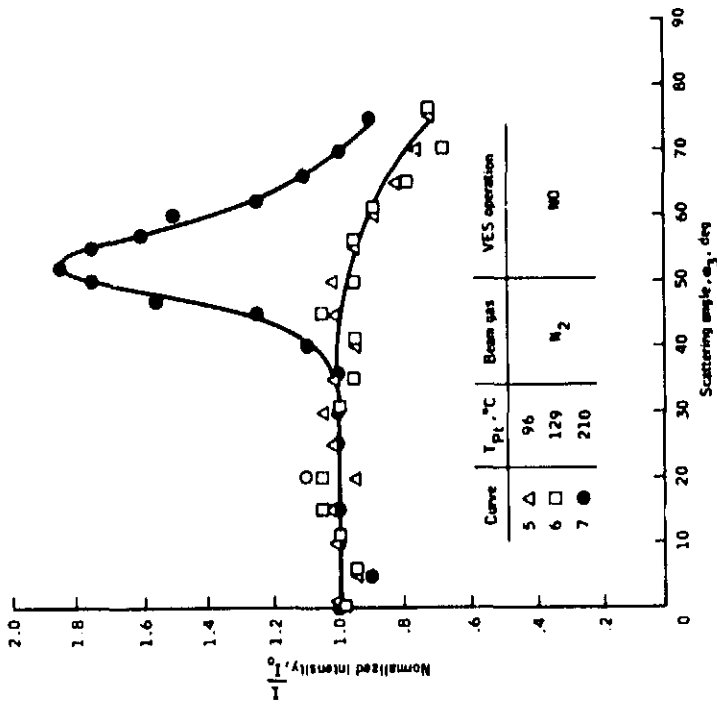

Figure 11.- Different scattering distributions for temperatures of the platinum surface T_{pt} in the range up to 110° C and for $T_{pt} = 185^{\circ}$ C.

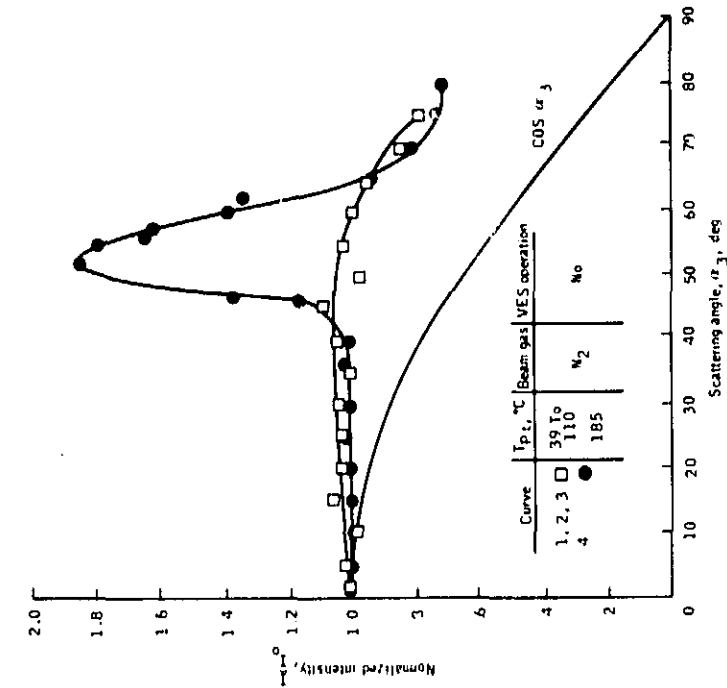

Figure 12.- Different scattering distribution for temperatures for the platinum surface T_{pt} in the range up to 129° C and for $T_{pt} = 210^{\circ}$ C.

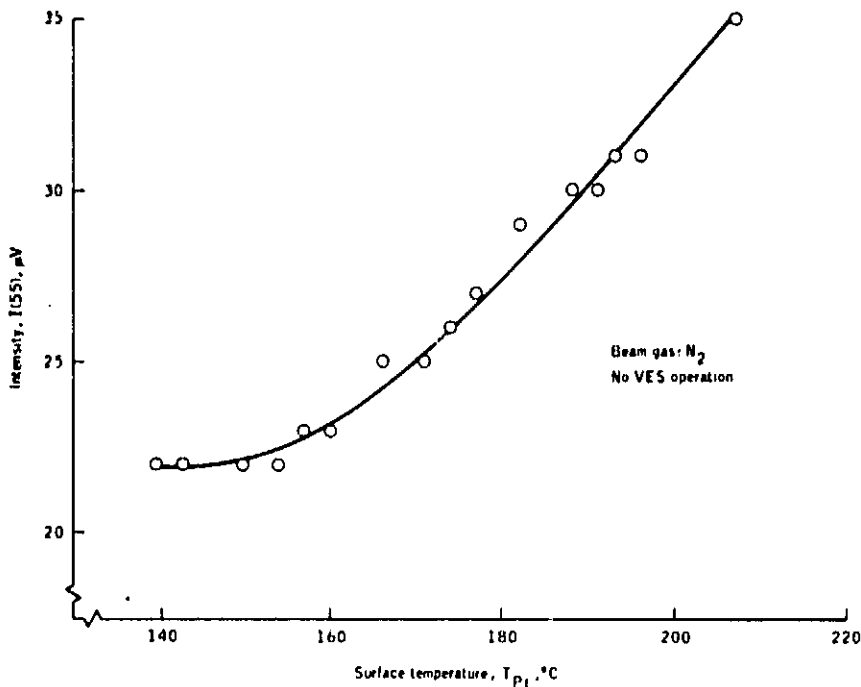

Figure 13.- Intensity for a scattering angle $\alpha_3 = 55^\circ$ as a function of surface temperature T_{Pt} .

Scattered N_2 Molecular Beam from Pt Surface After Operation of Vapor Effusion Source

On figs. 14 and 15 the intensity distributions of the scattered molecular beam are displayed after the vapor effusion source with DC 705 was operated. The vapor pressure in the source was $p_g = 5 \times 10^{-9}$ torr. The isolation valve to the vapor effusion source housing was opened and the Pt sample was not rotated to the VES opening. Figs. 14 and 15 indicate no specularly directed beam could be measured for surface temperatures of $T_{Pt} \geq 171^\circ C$. It is assumed, that this effect was caused by DC 705 effusing from the VES to different chamber surfaces and from these to the Pt surface.

This is confirmed by the measurements of fig. 15. A new sample was used that was apparently contaminated in the chamber by the secondary sources of DC 705.

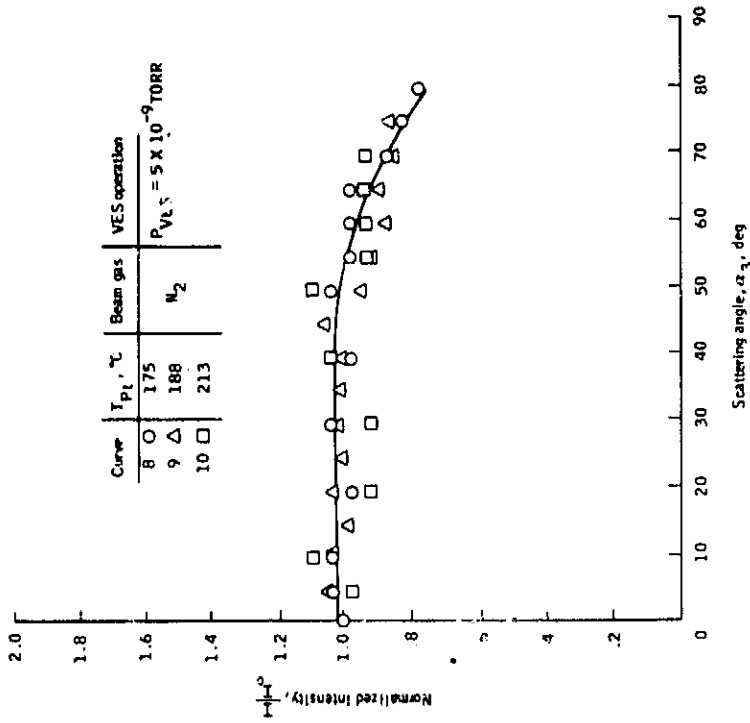

Figure 14.- Scattering distribution for surface temperature up to T_{pt} = 213° C after operation of vapor effusion source VES.

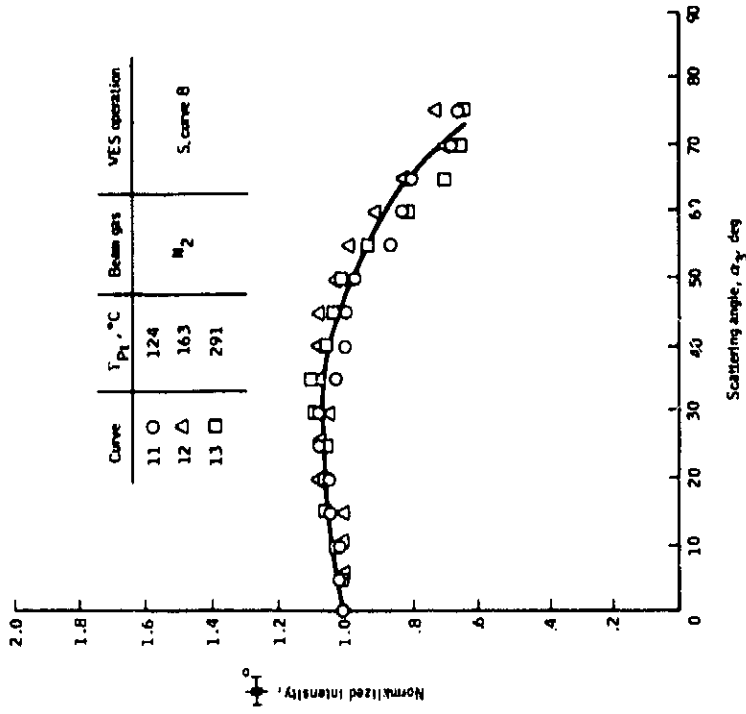

Figure 15.- Scattering distribution for surface temperatures up to T_{pt} = 291° C after operation of vapor effusion source VES.

Scattered He Molecular Beam from Pt Surface After Operation of Vapor Effusion Source (figs. 16 and 17)

The molecular beam gas was changed to He. According to other studies (refs. 72, 74) there should be a systematic shift in the maximum scattered beam toward the surface normal and an increased width as the result of an increased mass of the beam atom or a changed interaction energy. The results of fig. 16 demonstrate the increase of the maximum scattered beam intensity and decrease of the width of the scattered beam with increasing surface temperature. This indicates that with increasing surface temperature the removal of the contaminant from the surface progresses. The change in the scattering distributions caused by a contamination was confirmed by the fact that a clean surface displays a decrease of the maximum scattered intensity and an increase in width of the scattered beam with increasing surface temperature (ref. 59). For measuring a width and maximum of the scattered beam, the high surface temperature of $T_{pt} = 358^\circ$ of curve 17 was comparable to the results of figs. 11 and 12. Temperature $T_{pt} = 200^\circ$ C shows the influence of the DC 705 contamination, which has a much higher desorption energy than the background gases. With respect to the Pt surface normal the results of fig. 16 were found for an angle of incidence of the molecular beam of $\alpha_1 = 55^\circ$. The scattered beam maximum was measured for a scattering angle of $\alpha_3 = 45^\circ$, which indicates subspecular scattering as the results for N_2 .

The normalized intensity $I(45)/I_0$ of the scattered beam for a scattering angle $\alpha_3 = 45^\circ$ is plotted on fig. 17 as a function of surface temperature. The characterization of the contamination status after the VES operation (curve 8) and results of fig. 13 before contamination and fig. 17 after contamination may be compared. The results of fig. 13 were measured for a N_2 molecular beam and fig. 17 for a He molecular beam. If the change in the scattering distributions to specularly directed distributions as a function of surface temperature is considered, this comparison results in smaller differences than would be expected for comparing results for He or N_2 (figs. 14 and 15). The increase of the scattered beam intensity starts after the contamination at a surface temperature $T_{pt} = 200^\circ$ C ($T_{pt} = 160^\circ$ C before contamination). At $T_{pt} = 200^\circ$ C the ratio between the maximum scattered beam intensity and low temperature beam intensity is 1.04 (1.50 before contamination). For reaching a value of 1.5 for this ratio before contamination a surface temperature $T_{pt} = 200^\circ$ C was necessary but after contamination the necessary temperature was $T_{pt} = 358^\circ$ C.

On fig. 18 the curves 18 to 21 display reproducibility of the results of fig. 16 and reversible transition as a function of surface temperature. Before measuring curve 22 and vapor effusion source was operated at a vapor pressure of the DC 750 of $p_g = 5 \times 10^{-8}$ torr. The sample was rotated to the opening of the VES. The contamination deposition time was 5 minutes. Curve 22

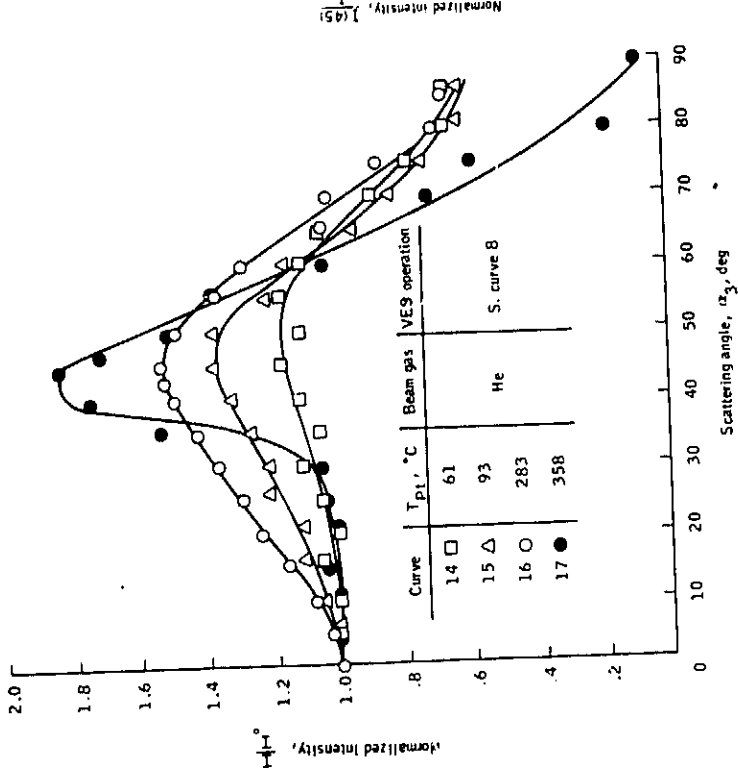

Figure 16.- Scattering distributions for an angle of incidence of $\alpha_1 = 55^\circ$ for different temperatures of platinum surface using helium as beam gas after operations of vapor effusion.

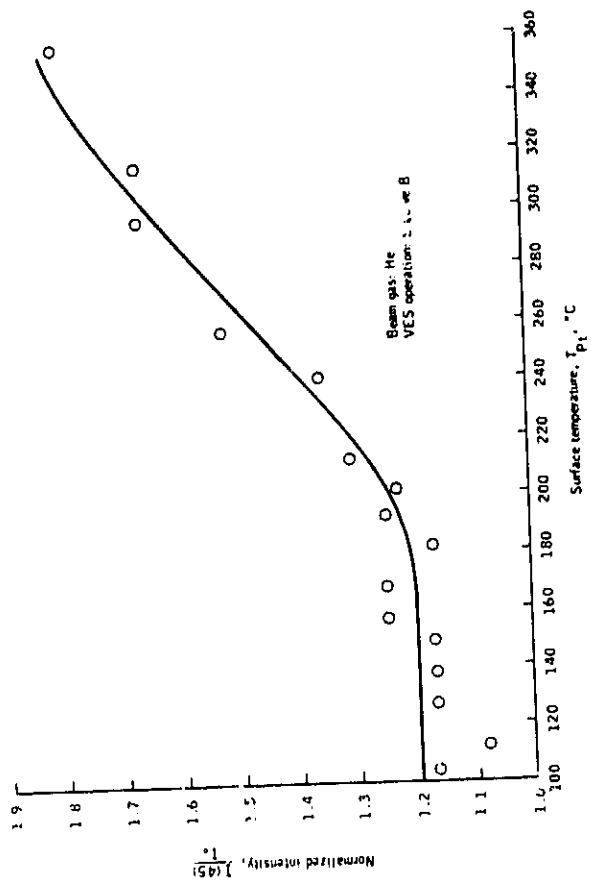

Figure 17.- Normalized intensity $I(45)/I_c$ for a scattering angle $\alpha_3 = 45^\circ$ as a function of surface temperature T_{pt} after operation of vapor effusion source VES.

of fig. 18 indicates the change of the scattering distribution from a "approximately diffuse" distribution with a specularly directed portion to a distribution, which is very close to a cosine function (curve 22).

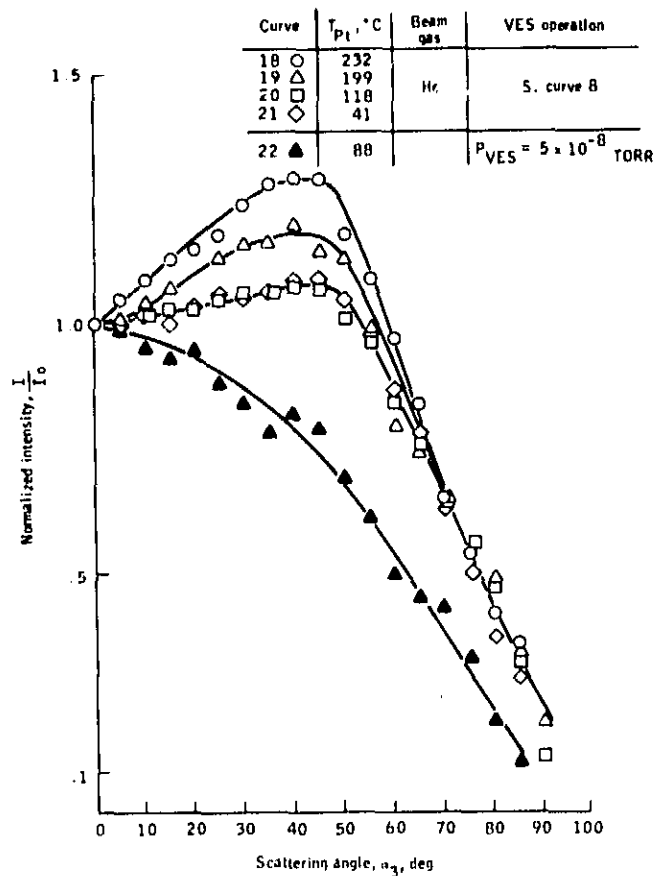

Figure 18.- Scattering distributions for different surface temperatures T_{pt} for two operations of vapor effusion source.

The results of fig. 19 measured after the contamination (curve 22) show a remarkable change of the scattering distribution. Also, surface temperatures up to 380° C for figs. 18, 17, and 16 are compared. For a surface temperature of 400° C the maximum scattered beam intensity increases to a value of $I/I_0 = 1.5$. Before contamination it was $I/I_0 = 1.8$ for $T_{pt} = 358^{\circ}$ C (fig. 16).

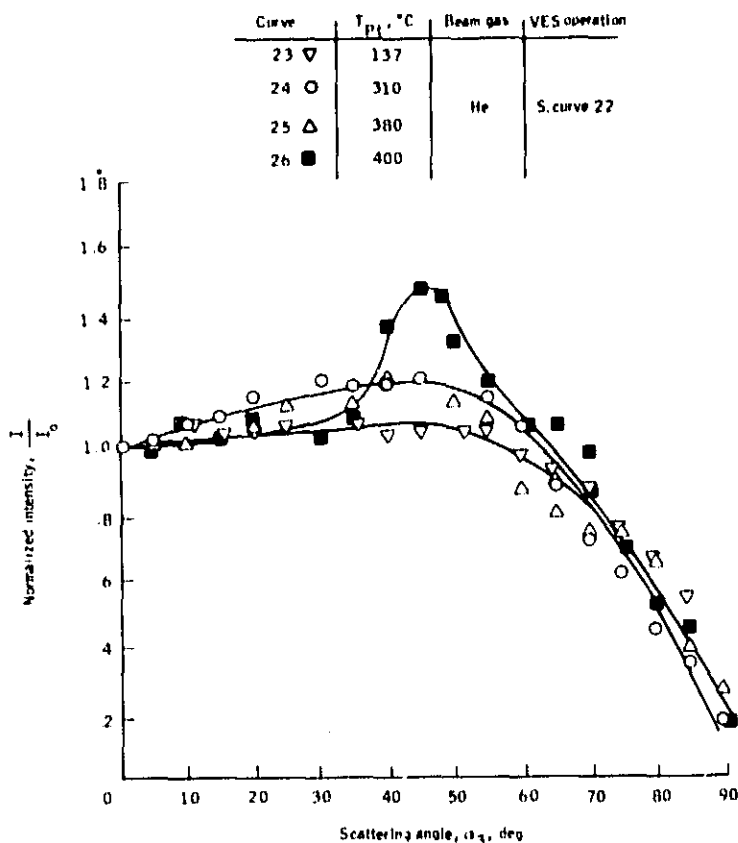

Figure 19.- Scattering distributions for temperature up to $T_{Pt} = 400^{\circ} C$ after two operations of vapor effusion source.

The capability of molecular beam scattering for the detection of contamination is summarized and the present investigation indicates the possibilities for defining the contamination status of the Pt surface are:

1. Measurement of the change of the scattering distribution at surface temperatures above $T_{Pt} = 200^{\circ} C$ (figs. 11, 12, 13, 14, 16, 17, 18, and 19) or at surface temperatures $T_{Pt} = 50^{\circ} C$ (curve 22 of fig. 18).
2. Measurement of the change in the temperature dependence of the maximum scattered beam intensity (figs. 13 and 17).

An estimation of the order of magnitude for the amount of DC 705 contaminant on the Pt surface can be carried out according to measurements with the vapor effusion source and quartz microbalance as a detector (19). A value for the deposition rate in the present studies of smaller $5 \text{ \AA}/\text{min}$ can be evaluated from these data. The evaporation rate for a surface temperature of $50^{\circ} C$ was measured to be $8 \text{ \AA}/\text{min}$ (ref. 19). Therefore, in the present study the contaminant film has to be assumed as parts of a monolayer. Calculating the mean

residence time T_r of particles at the surface according to equation for a surface temperature of 350°C show the results can only be explained for desorption energies greater than 50 K cal/mole . This seems to be a reasonable order of magnitude if the results for the binding energy of 43 K cal/mole of DC 704 on gold substrates are considered (ref. 21).

A possible application of the described method is to use a similar measuring setup for the detection of contamination of sensitive optical or thermal control surfaces of spacecraft during space environment tests. There will be very few arrangements where the molecular beam can be directed to the sensitive surface and a surface temperature variation of the order of mentioned magnitude is possible. Therefore, the applications will be restricted more for scattering from a sample surface, which is approximately at the same temperature as the sensitive optical surface to be investigated. Because of this the described measuring method at surface temperatures $T_{pt} = 50^\circ\text{C}$ has a possibility of application for spacecraft subsystems whereas the high temperature ($T_{pt} = 200^\circ\text{C}$) measurements can be made for small components or samples in development studies.

Recommended for future studies are additional investigations at surface temperatures of approximately 50°C , change of the contaminant; extension of the surface temperature range of approximately 700°C ; and, setting-up for the vapor effusion source and molecular beam source to make possible the simultaneous irradiation of the surface sample. Besides the aspect of contamination detection, there exists the usefulness of molecular beam scattering for studying energy exchange between gas particle and surfaces and the measurement of scattering distribution of gas particles from spacecraft and space simulation chamber surface.

REPRODUCIBILITY OF THE
ORIGINAL PAGE IS POOR

REFERENCES

- (1) Shapiro, H.: Monomolecular Contamination of Optical Surfaces, NASA TND 4612, 1968.
- (2) Hass, G.; Hunter, W. R.: Laboratory Experiments to Study Surface Contamination and Degradation of Optical Coatings and Materials in Simulated Space Environments, Appl. Opt. Vol 9, 1970, p. 2101.
- (3) Viehmann, W.; Eubanks, A. G.: Effects of Surface Contamination on the infrared Emissivity and Visible-Light Scattering of Highly Reflective Surfaces at Cryogenic Temperatures, NASA SP 298, 1972, p. 489.
- (4) Moore, W. W.: Environmental Simulation Testing of Solar Cell Contamination by Hydrazine, NASA SP 298, 1972, p. 461.
- (5) Fleischauer, P. D.; Tolentini, L.: The Far Ultraviolet Photolysis of Polymethyl-phenylsiloxane Films on Quartz Substrates, NASA SP 336, 1973, p. 645.
- (6) Jones, P. F.: Radiation Effects on Contaminants from the Outgassing of Silastic 140 RTV, NASA SP 298, p. 173.
- (7) Hearsel, P. J.: Effect of Photodegradation on Organic Coatings, NBS SP 336, 1970, p. 299.
- (8) Scialdone, T. T.: Predicting Spacecraft Self-Contamination in Space and in a Test Chamber, NASA SP 298, p. 349.
- (9) Naumann, R. J.: Dynamics of Spacecraft Contamination, NASA SP 298, 1972, p. 405.
- (10) Lee, A. L.; Robertson, S. T.; Ehlers, H. K. F.: Mathematical Model of Molecular Flow in the NASA-JSC Thermal-Vacuum Chamber A, NASA SP336, 1973, p. 757.
- (11) Ehlers, H. K. F.: Directional Molecular Flow Analysis and Leak Detection with Rotatable Gas Analyser in a Large Space Simulation Chamber, NASA SP 298, 1972, p. 789.
- (12) Visentine, J. T.; Ogden, J. W.; Ritter, M. L.; Smith, U.: Preparation, Verification and Operational Control of a Large Space Environment Simulation Chamber for Contamination Sensitive Tests, NASA SP 298, p. 361.
- (13) Wolff, C. M.; Ritter, M. L.: Contamination Measurements in Space Environment Simulation Chambers, NBS SP 336, 1970, p. 25.
- (14) Richmond, R. G.; Harmon, H. N.: An Instrument for Real-Time Detection of Contamination in Space Environmental Test Chambers, NASA SP 298, p. 503.

- (15) Enlow, D. L.: Contamination Studies in a Space Simulated Environment, NBS SP 336, 1970, p. 51.
- (16) Moore, B. C.; Camarillo, R. G.; Kringe, L. C.: Contamination Control in Space Simulation Chambers, NASA SP 336, 1973, p. 265.
- (17) Holland, L.: Contamination in Ultra-High Vacuum Plant, Rev. Sci. Instr. Vol. 34, 1963, p. 377.
- (18) Goldsmith, J. C.; Nelson, E. R.: Molecular Contamination in Environmental Testing at Goddard Space Flight Center, NBS SP 336, 1970, p. 1.
- (19) Dillow, C. F.; Allen, T. H.; Linford, R. M. F.; Richmond, R. G.: A System For The Study of Molecular Contamination, NASA SP 379, 1975, p. 623.
- (20) Mc Keown, D.; Corburn, W. E.; Naumann, R. J.: Thermoelectrically Cooled Quartz Crystal Microbalance, NASA SP 336, 1973, p. 345.
- (21) Allen, T. H.: The Study of Molecular Contamination Kinetics Using Ellipsometry, NASA SP 336, 1973, p. 605.
- (22) Dormant, L.: Use of Ellipsometry for the Quantitative Detection of Contaminants on Second Surface Mirrors, NASA SP 336, 1973, p. 607.
- (23) Clancy, H. M.: Vacuum Stability Testing of Apollo 15 Scientific Instrument Module (SIM) Non-Metallic Materials and Reversion of Silicone Rubber in a Motor Switch, NASA SP 298, 1972, p. 107.
- (24) Arnett, G. M.; Linton, R. C.: Integrated Realtime Contamination Monitor: Optical Module, NASA SP 298, 1972, p. 179.
- (25) Tashbar, P. W.; Nisen, D. B.; Moore, W. W.: V-3 Contamination Test in the Manned Spacecraft Center's Vacuum Chamber A, NASA SP 298, 1972, p. 389.
- (26) Wallace, D. A.; Chuan, R. L.: The Use of a Quartz Crystal Micro-Balance and an Optical Reflectometer to Determine Contaminant Material Optical Constants, NASA SP 298, 1972, p. 521.
- (27) Dauphin, J.; Schamle, G.; Zwaal, A.: Some Contamination Problems in the European TD Satellite, NASA SP 298, 1972, p. 613.
- (28) Kruger, R.; Scialdone, J. J.; Shapiro, H.: A Comparison of Quartz Crystal Microbalance Measurements with Mass Spectrometer Determinations, NASA SP 298, 1972, p. 115.
- (29) McKeown, D.; Corburn, W. E.: Space Measurements of the Contamination of Surfaces by OGO-6 Outgassing and their Cleaning by Sputtering and Desorption, NBS SP 336, 1970, p. 113.

- (30) Kruger, R.: A Contamination Experiment Investigating the Failure of the Nimbus IV Filter Wedge Spectrometer, NASA SP 298, 1972, p. 469.
- (31) Leger, L. J.: Apollo Experience Report — Window Contamination, NASA TN D-6721, March 1972.
- (32) Saylor, W. P.: Measurement of Condensate Film Contamination on Critical Surfaces by Charged Particle Excited X-ray Fluorescence, NASA SP 336, 1973, p. 401.
- (33) Smathers, J. B.; Kuykendall, W. E.; Wright, R. E.; Marshall, J. R.: Evaluation of Radioisotope Tracer and Activation Analysis Techniques for Contamination Monitoring in Space Environment Simulation Chambers, NASA SP 336, 1973, p. 421.
- (34) Hayes, J. D.; Richmond, R. G.; Chatterton, N. E.: Development of Techniques for Advanced Optical Contamination Measurement with Internal Reflection Spectroscopy, NASA SP 336, 1973, p. 609.
- (35) Wolff, C. M.: Some New Techniques in Passive Contaminant Analysis of Space Environ. Simulation Chambers, NASA SP 298, 1972, p. 151.
- (36) Williams, J. R.; Kurtz, R. L.: Holographic Analysis of Particle Size Distribution and Particle Velocities for Skylab Contamination Ground Test.
- (37) Jensen, L. B.; McCauley, G. B.; Honma, M.: A Vacuum Thermo-gravimetric Method for Out-Gassing Evaluation of Silicone Coated Fiberglass Cloth, NASA SP 298, 1972, p. 831.
- (38) Smith, K.F.: Molecular Beams, Wiley, New York, 1955.
- (39) Ramsey, N. F.: Molecular Beams, Clarendon Press, Oxford, 1956.
- (40) Estermann, I.: Recent Research in Molecular Beams, Academic Press, New York, 1959.
- (41) Hughes, V. W.; Schulz, H. L. (Editors): Atomic and Electron Physics Part A, Atomic Sources and Detectors, Academic Press, New York, 1967, pp. 155-198 and 390-414.
- (42) Bederson, B.; Fite, W. L. (Editors): Atomic and Electron Physics, Atomic Interactions Part A, Methods of Experimental Physics, Academic Press, New York, 1968.
- (43) de Boer, J. H.: The Dynamical Character of Adsorption, Clarendon Press, Oxford, 1968.

- (44) Smith, J. N.; Fite, W. L.: Recent Investigations of Gas-Surface Interactions using Modulated-Atomic-Beam Techniques, Proc. of 3rd Intern. Symp. Rarefied Gas Dynamics 1962, Academic Press, New York, 1963, p. 430.
- (45) Saltsburg, H.; Smith, J. N.; Palmer, R. L.: Scattering of Molecular Beams of He, D₂, and H₂ from the (111) Plane of Ag, Proc. 5th Intern. Symp. Rarefied Gas Dynamics 1966, Academic Press, New York 1967, p. 223.
- (46) Smith, J. N.; Saltsburg, H.: Molecular Beam Scattering from Solid Surfaces, Fundamentals of Gas-Surface Interactions, H. Saltsburg, J. N. Smith, M. Rogers eds., Academic Press, New York, 1967, p. 370.
- (47) Hurlbut, F. C.: Current Developments in the Study of Gas-Surface Interactions, Proc. 5th Intern. Symp. Rarefied Gas Dynamics 1966, Academic Press, New York, 1967, p. 1.
- (48) Smith, J. N.; Saltsburg, H.; Palmer, R. L.: The Scattering of He, Ne, Ar, and Xe from the (111) Plane of Ni; Comparison with Ag (111) and Au (111), Proc. 6th Intern. Symp. Rarefied Gas Dynamics 1968, Academic Press, New York, 1969, p. 1141.
- (49) Jakus, K.; Hurlbut, F. C.: Gas Surface Scattering Studies Using Nozzle Beams and Time-of-Flight Techniques, p. 1171.
- (50) O'Keefe, D. R.; French, J. B.: High Energy Scattering of Inert Gases from Well Characterized Surfaces I. Experimental, p. 1279.
- (51) Hurlbut, F. C.: Current Experiments and Open Questions in Gas Surface Scattering, Proc. 9th Intern. Symp. Rarefied Gas Dynamics 1970, DFVLR Press, Porz-Wahn, West Germany, 1974, p. Ax. - E3-1.
- (52) Smith, J. N.: Non-reactive Scattering of Molecular Beams from Solid Surfaces: A review, Proc. 8th Intern. Symp. Rarefied Gas Dynamics 1972, Academic Press, New York, 1974, p. 345.
- (53) Trilling, L.: Theory of Gas Surface Collisions, Fundamentals of Gas-Surface Interactions, H. Saltsburg, J. N. Smith, M. Rogers eds., Academic Press, New York, 1967, p. 392.
- (54) Stickney, R. P.; Logan, R. M.; Yamamoto, S.; Keck, J. C.: Simple Classical Model for the Scattering of Gas Atoms from a Solid Surface, p. 422.
- (55) Henry, T. J.: The Scattering of Particles from Rough Surfaces, p. 435.
- (56) Trilling, L.: The Scattering of Inert Gases on Solid Surfaces, Proc. 7th Intern. Symp. Rarefied Gas Dynamics 1970, Academic Press, New York, 1971, p. 45.

- (57) Cercignani, C.: Models for Gas Surface Interactions: Comparison Between Theory and Experiment, p. 75.
- (58) Goodman, F. O.: Review of the Theory of the Scattering of Gas Atoms by Solid Surfaces, p. 1.
- (59) Smith, D. L.; Merrill, R. P.: Concurrent Low Energy Diffraction and Deuterium Molecular Beam Scattering Studies of Clean and Contaminated Pt (111), Proc. 6th Intern. Symp. Rarefied Gas Dynamics 1968, Academic Press, New York, 1969, p. 1159.
- (60) Datz, S.; Moore, G. E.; Taylor, E. H.: The Reflection of Modulated Helium and Deuterium Molecular Beams from Platinum Surfaces; Proc. 3rd Intern. Symp. Rarefied Gas Dynamics 1962, Academic Press, New York, 1963, p. 347.
- (61) Hinchey, J. J.; Malloy, E. S.: Velocity of Molecular Beam Molecules Scattered by Platinum Surfaces, Fundamentals of Gas-Surface Interactions, H. Saltsburg, T. N. Smith, M. Rogers eds., Academic Press, New York, 1967, p. 448.
- (62) Hinchey, J. J.; Sheperd, E. F.: Molecular Beam Scattering from Surfaces of Various Metals, Proc. 5th Intern. Symp. Rarefied Gas Dynamics 1966, Academic Press, New York, 1967, p. 239.
- (63) Smith, J. N.; Saltsburg, H.: Atomic-Beam Scattering from Epitaxially Grown Gold Films, J. Chem. Phys. 40, 1964, p. 3585.
- (64) Griffith, J. S.: Some Tests for the Increase in Friction of Mechanisms of the Mariner Mars 1969 Spacecraft in the JPL Molsink Space Simulation Chamber, AIAA/ASTM/IES 4th Space Simulation Conf. 1969, Paper 69-996.
- (65) D. Jaeger: Einfluss von an der Oberflaeche adsorbierten Gasteilchen und Einfluss von Struktur auf die Gas-Festkoerper-Wechselwirkung gemessen an der Molekular-strahlstreuung, Deutsche Luft-und Raumfahrt, Forschungsbericht 73-14.
- (66) Schaetzle, W. J.: Some Experimental Data on Momentum Accommodation Coefficients: Proc. 5th Intern. Symp. Rarefied Gas Dynamics 1966, Academic Press, New York, 1967, p. 211.
- (67) Evlanov, E. N.; Lebedev, Yu. V.; Leonas, V. B.: On the Possible Method of Gas-Satellite Surface Interaction Studies, Proc. 9th Intern. Symp. Rarefied Gas Dynamics, 1974 DFVLR Press, Porz-Wahn, West Germany, 1974, p. E 16-1.
- (68) Knechtel, E. D.; Pitts, W. C.: Experimental Momentum Accommodation on Metal Surfaces of Ions Near and Above Earth Satellite Speeds, 6th Intern. Symp. Rarefied Gas Dynamics 1968, Academic Press, New York, 1969, p. 1257.

- (69) Feuer, P.: Quantum Theory of the Accommodation Coefficient and the Effect of Surface Impurities, Proc. 7th Intern. Symp. Rarefied Gas Dynamics 1970, Academic Press, New York, 1971, p. 203.
- (70) Estermann, I.; Stern, O.: Z. Fuer Physik 61, 1930, p. 95.
- (71) Crews, J. C.: Scattering of Helium and Argon from the Cleavage Plane of Lithium Fluoride, J. Chem. Phys. 37, 1962, p. 2004.
- (72) Smith, J. N. Scattering of Atomic Beams by Polycrystalline Nickel, J. Chem. Phys. 40, 1964, p. 2520.
- (73) Hinchey, J.J.; Foley, W. M.: Scattering of Molecular Beams by Metallic Surfaces, Proc. 4th Intern. Symp. Rarefied Gas Dynamics 1964, Academic Press, New York, 1966, p. 505.
- (74) Grimley, R. T. LaRue, J.: A Mass Spectrometric Study of the Angular Distribution of Vapor Species Effusing through Cylindrical Orifices at High Temperatures, Proc. 6th Intern. Symp. Rarefied Gas Dynamics 1968, Academic Press, New York, 1969, p. 1455.
- (75) Vacuum Technology and Space Simulation, NASA SP 105, 1967, p. 197.
- (76) Stevenson, D. P.: Heat of Chemisorption of Hydrogen in Metals, J. Chem. Phys. 23, 1955, p. 203.
- (77) Clausius, P.: Ueber die Stroemung sehr verduennter Gase durch Roehren von beider Laenge, Ann. Physik 12, 1932, p. 961.
- (78) Gioremaine, J. A.; Wang, T. C.: J. Appl. Phys. 31, 1960, p. 458.
- (79) Brackmann, R. T., Fite, W. L.: Condensation of Atomic and Molecular Hydrogen at Low Temperatures, J. Chem. Phys. 34, 1964, p. 1572.
- (80) Fite, W. L.; Brackmann, R. T.: Collisions of Electrons with Hydrogen Atoms, I. Ionization, Phys. Rev. 112, 1958, p. 1141.
- (81) Fite, W. L., Brackmann, R. T.: Collisions of Electrons with Hydrogen Atoms II. Excitation of Lyman-Alpha Radiation, Phys. Rev. 112, 1958, p. 1154.
- (82) Brackmann, R. T.; Fite, W. L.; Neynhaber, R. H.: Collisions of Electrons with Hydrogen Atoms III. Elastic Scattering, Phys. Rev. 112, 1958, p. 1157.
- (83) Fite, W. L.; Brackmann, R. T.; Snow, W. R.: Charge Exchange in Proton-Hydrogen-Atom Collisions, Phys. Rev. 112, 1958, p. 1161.
- (84) Freeman, R. D.: Molecular Flow and the Effusion Process in the Measurement of Vapor Pressures, Report ASD-TDR-63-754, Pt III, 1967.

- (30) Kruger, R.: A Contamination Experiment Investigating the Failure of the Nimbus IV Filter Wedge Spectrometer, NASA SP 298, 1972, p. 469.
- (31) Leger, L. J.: Apollo Experience Report — Window Contamination, NASA TN D-6721, March 1972.
- (32) Saylor, W. P.: Measurement of Condensate Film Contamination on Critical Surfaces by Charged Particle Excited X-ray Fluorescence, NASA SP 336, 1973, p. 401.
- (33) Smathers, J. B.; Kuykendall, W. E.; Wright, R. E.; Marshall, J. R.: Evaluation of Radioisotope Tracer and Activation Analysis Techniques for Contamination Monitoring in Space Environment Simulation Chambers, NASA SP 336, 1973, p. 421.
- (34) Hayes, J. D.; Richmond, R. G.; Chatterton, N. E.: Development of Techniques for Advanced Optical Contamination Measurement with Internal Reflection Spectroscopy, NASA SP 336, 1973, p. 609.
- (35) Wolff, C. M.: Some New Techniques in Passive Contaminant Analysis of Space Environ. Simulation Chambers, NASA SP 298, 1972, p. 151.
- (36) Williams, J. R.; Kurtz, R. L.: Holographic Analysis of Particle Size Distribution and Particle Velocities for Skylab Contamination Ground Test.
- (37) Jensen, L. B.; McCauley, G. B.; Honma, M.: A Vacuum Thermo-gravimetric Method for Out-Gassing Evaluation of Silicone Coated Fiberglass Cloth, NASA SP 298, 1972, p. 831.
- (38) Smith, K.F.: Molecular Beams, Wiley, New York, 1955.
- (39) Ramsey, N. F.: Molecular Beams, Clarendon Press, Oxford, 1956.
- (40) Estermann, I.: Recent Research in Molecular Beams, Academic Press, New York, 1959.
- (41) Hughes, V. W.; Schulz, H. L. (Editors): Atomic and Electron Physics Part A, Atomic Sources and Detectors, Academic Press, New York, 1967, pp. 155-198 and 390-414.
- (42) Bederson, B.; Fite, W. L. (Editors): Atomic and Electron Physics, Atomic Interactions Part A, Methods of Experimental Physics, Academic Press, New York, 1968.
- (43) de Boer, J. H.: The Dynamical Character of Adsorption, Clarendon Press, Oxford, 1968.

- (44) Smith, J. N.; Fite, W. L.: Recent Investigations of Gas-Surface Interactions using Modulated-Atomic-Beam Techniques, Proc. of 3rd Intern. Symp. Rarefied Gas Dynamics 1962, Academic Press, New York, 1963, p. 430.
- (45) Saltsburg, H.; Smith, J. N.; Palmer, R. L.: Scattering of Molecular Beams of He, D₂, and H₂ from the (111) Plane of Ag, Proc, 5th Intern. Symp. Rarefied Gas Dynamics 1966, Academic Press, New York 1967, p. 223.
- (46) Smith, J. N.; Saltsburg, H.: Molecular Beam Scattering from Solid Surfaces, Fundamentals of Gas-Surface Interactions, H. Saltsburg, J. N. Smith, M. Rogers eds., Academic Press, New York, 1967, p. 370.
- (47) Hurlbut, F. C.: Current Developments in the Study of Gas-Surface Interactions, Proc. 5th Intern. Symp. Rarefied Gas Dynamics 1966, Academic Press, New York, 1967, p. 1.
- (48) Smith, J. N.; Saltsburg, H.; Palmer, R. L.: The Scattering of He, Ne, Ar, and Xe from the (111) Plane of Ni; Comparison with Ag (111) and Au (111), Proc. 6th Intern. Symp. Rarefied Gas Dynamics 1968, Academic Press, New York, 1969, p. 1141.
- (49) Jakus, K.; Hurlbut, F. C.: Gas Surface Scattering Studies Using Nozzle Beams and Time-of-Flight Techniques, p. 1171.
- (50) O'Keefe, D. R.; French, J. B.: High Energy Scattering of Inert Gases from Well Characterized Surfaces I. Experimental, p. 1279.
- (51) Hurlbut, F. C.: Current Experiments and Open Questions in Gas Surface Scattering, Proc. 9th Intern. Symp. Rarefied Gas Dynamics 1974, DFVLR Press, Porz-Wahn, West Germany, 1974, p. Ax. - E3-1.
- (52) Smith, J. N.: Non-reactive Scattering of Molecular Beams from Solid Surfaces: A review, Proc. 8th Intern. Symp. Rarefied Gas Dynamics 1972, Academic Press, New York, 1974, p. 345.
- (53) Trilling, L.: Theory of Gas Surface Collisions, Fundamentals of Gas-Surface Interactions, H. Saltsburg, J. N. Smith, M. Rogers eds., Academic Press, New York, 1967, p. 392.
- (54) Stickney, R. E.; Logan, R. M.; Yamamoto, S.; Keck, J. C.: Simple Classical Model for the Scattering of Gas Atoms from a Solid Surface, p. 422.
- (55) Healy, T. J.: The Scattering of Particles from Rough Surfaces, p. 435.
- (56) Trilling, L.: The Scattering of Inert Gases on Solid Surfaces, Proc. 7th Intern. Symp. Rarefield Gas Dynamics 1970, Academic Press, New York, 1971, p. 55.

- (57) Cercignani, C.: Models for Gas Surface Interactions: Comparison Between Theory and Experiment, p. 75.
- (58) Goodman, F. O.: Review of the Theory of the Scattering of Gas Atoms by Solid Surfaces, p. 1.
- (59) Smith, D. L.; Merrill, R. P.: Concurrent Low Energy Diffraction and Deuterium Molecular Beam Scattering Studies of Clean and Contaminated Pt (111), Proc. 6th Intern. Symp. Rarefied Gas Dynamics 1968, Academic Press, New York, 1969, p. 1159.
- (60) Datz, S.; Moore, G. E.; Taylor, E. H.: The Reflection of Modulated Helium and Deuterium Molecular Beams from Platinum Surfaces; Proc. 3rd Intern. Symp. Rarefied Gas Dynamics 1962, Academic Press, New York, 1963, p. 347.
- (61) Hinchey, J. J.; Malloy, E. S.: Velocity of Molecular Beam Molecules Scattered by Platinum Surfaces, Fundamentals of Gas-Surface Interactions, H. Saltsburg, T. N. Smith, M. Rogers eds., Academic Press, New York, 1967, p. 448.
- (62) Hinchey, J. J.; Sheperd, E. F.: Molecular Beam Scattering from Surfaces of Various Metals, Proc. 5th Intern. Symp. Rarefied Gas Dynamics 1966, Academic Press, New York, 1967, p. 239.
- (63) Smith, J. N.; Saltsburg, H.: Atomic-Beam Scattering from Epitaxially Grown Gold Films, J. Chem. Phys. 40, 1964, p. 3585.
- (64) Griffith, J. S.: Some Tests for the Increase in Friction of Mechanisms of the Mariner Mars 1969 Spacecraft in the JPL Molsink Space Simulation Chamber, AIAA/ASTM/IES 4th Space Simulation Conf. 1969, Paper 69-996.
- (65) D. Jaeger: Einfluss von an der Oberflaeche adsorbierten Gasteilchen und Einfluss von Struktur auf die Gas-Festkoerper-Wechselwirkung gemessen an der Molekular-strahlstreuung, Deutsche Luft-und Raumfahrt, Forschungsbericht 73-14.
- (66) Schaetzle, W. J.: Some Experimental Data on Momentum Accommodation Coefficients: Proc. 5th Intern. Symp. Rarefied Gas Dynamics 1966, Academic Press, New York, 1967, p. 211.
- (67) Evlanov, E. N.; Lebedev, Yu. V.; Leonas, V. B.: On the Possible Method of Gas-Satellite Surface Interaction Studies, Proc. 9th Intern. Symp. Rarefied Gas Dynamics, 1974 DFVLR Press, Porz-Wahn, West Germany, 1974, p. E 16-1.
- (68) Knechtel, E. D.; Pitts, W. C.: Experimental Momentum Accommodation on Metal Surfaces of Ions Near and Above Earth Satellite Speeds, 6th Intern. Symp. Rarefied Gas Dynamics 1968, Academic Press, New York, 1969, p. 1257.

- (69) Feuer, P.: Quantum Theory of the Accommodation Coefficient and the Effect of Surface Impurities, Proc. 7th Intern. Symp. Rarefied Gas Dynamics 1970, Academic Press, New York, 1971, p. 203.
- (70) Estermann, I.; Stern, O.: Z. Fuer Physik 61, 1930, p. 95.
- (71) Crews, J. C.: Scattering of Helium and Argon from the Cleavage Plane of Lithium Fluoride, J. Chem. Phys. 37, 1962, p. 2004.
- (72) Smith, J. N. Scattering of Atomic Beams by Polycrystalline Nickel, J. Chem. Phys. 40, 1964, p. 2520.
- (73) Hinchey, J.J.; Foley, W. M.: Scattering of Molecular Beams by Metallic Surfaces, Proc. 4th Intern. Symp. Rarefied Gas Dynamics 1964, Academic Press, New York, 1966, p. 505.
- (74) Grimley, R. T. LaRue, J.: A Mass Spectrometric Study of the Angular Distribution of Vapor Species Effusing through Cylindrical Orifices at High Temperatures, Proc. 6th Intern. Symp. Rarefied Gas Dynamics 1968, Academic Press, New York, 1969, p. 1455.
- (75) Vacuum Technology and Space Simulation, NASA SP 105, 1967, p. 197.
- (76) Stevenson, D. P.: Heat of Chemisorption of Hydrogen in Metals, J. Chem. Phys. 23, 1955, p. 203.
- (77) Clausing, P.: Ueber die Stroemung sehr verduennter Gase durch Roehren von beliebigiger Laenge, Ann. Physik 12, 1932, p. 961.
- (78) Giorèmaine, J. A.; Wang, T. C.: J. Appl. Phys. 31, 1960, p. 458.
- (79) Brackmann, R. T.; Fite, W. L.: Condensation of Atomic and Molecular Hydrogen at Low Temperatures, J. Chem. Phys. 34, 1964, p. 1572.
- (80) Fite, W. L.; Brackmann, R. T.: Collisions of Electrons with Hydrogen Atoms, I. Ionization, Phys. Rev. 112, 1958, p. 1141.
- (81) Fite, W. L., Brackmann, R. T.: Collisions of Electrons with Hydrogen Atoms II. Excitation of Lyman-Alpha Radiation, Phys, Rev. 112, 1958, p. 1151.
- (82) Brackmann, R. T.; Fite, W. L.; Neynhaber, R. H.: Collisions of Electrons with Hydrogen Atoms III. Elastic Scattering, Phys. Rev. 112, 1958, p. 1157.
- (83) Fite, W. L.; Brackmann, R. T.; Snow, W. R.: Charge Exchange in Proton-Hydrogen-Atom Collisions, Phys. Rev. 112, 1958, p. 1161.
- (84) Freeman, R. D.: Molecular Flow and the Effusion Process in the Measurement of Vapor Pressures, Report ASD-TDR-63-754, Pt III, 1967.