

## **General Disclaimer**

### **One or more of the Following Statements may affect this Document**

- This document has been reproduced from the best copy furnished by the organizational source. It is being released in the interest of making available as much information as possible.
- This document may contain data, which exceeds the sheet parameters. It was furnished in this condition by the organizational source and is the best copy available.
- This document may contain tone-on-tone or color graphs, charts and/or pictures, which have been reproduced in black and white.
- This document is paginated as submitted by the original source.
- Portions of this document are not fully legible due to the historical nature of some of the material. However, it is the best reproduction available from the original submission.

**TX-6340-77**

# **GEOS-C COHERENT C-BAND TRANSPONDER**

## **TEST PROCEDURE**

### **FOR**

(NASA-TM-X-69362) GEOS-C COHERENT C-BAND  
TRANSPONDER TEST PROCEDURE FOR SPACECRAFT  
LEVEL TESTS (NASA) 31 p HC \$4.00 CSCL 17B

N76-19315

Unclas

G3/32 20637

## **SPACECRAFT LEVEL TESTS**

**NASA**

National Aeronautics and  
Space Administration

**Wallops Flight Center**  
Wallops Island, Virginia 23337  
AC 804 824-3411



GEOS-C COHERENT C-BAND TRANSPONDER

TEST PROCEDURE

FOR

SPACECRAFT LEVEL TESTS

PREPARED BY: Alan R. Selser 8/1/73  
A. R. Selser  
C-Band Technical Consultant

CONCURRENCE: Earl B. Jackson 8/1/73  
E. B. Jackson  
C-Band Subsystems Manger

V. L. Yeffstig 8/3/73  
V. L. Yeffstig  
Spacecraft Systems Manger

## TABLE OF CONTENTS

	<u>PAGE</u>
SECTION 1.0 - SCOPE	1
SECTION 2.0 - CLASSIFICATION OF TESTS	1
2.1 Electrical Performance Test	1
2.2 Airlink Test	1
SECTION 3.0 - RECORD OF TEST	1
SECTION 4.0 - C-BAND TEST CONSOLE	1
4.1 Equipment Supplied	1
4.2 Test Setup	3
4.3 Functional Controls	3
4.4 Initial Conditions	3
4.5 C-Band Test Console Calibration Procedures	4
SECTION 5.0 - ELECTRICAL PERFORMANCE TEST	7
5.1 Transponder Turn On	7
5.2 TM Functions Vs. PRF	8
5.3 Receiver Sensitivity at 5690 MHz	8
5.4 Receiver Bandwidth	8
5.5 Receiver Code Spacing	9
5.6 Peak Power Output	10
5.7 Transmitter Pulse Width and Pulse Width Jitter	10
5.8 Delay and Delay Jitter Vs. Receiver Signal Level	10
5.9 Frequency Error	11
5.10 Pulling Range	12
5.11 Interline Noise	12
5.12 Transponder Turn Off	12



TABLE OF CONTENTS (CONT'D)

	<u>PAGE</u>
SECTION 6.0 - AIRLINK TEST	13
6.1 Transponder Turn On	13
6.2 Receiver Code Spacing	13
6.3 Transmitter Pulse Width	14
6.4 Delay Vs. Relative Signal Level	14
6.5 Frequency Error	15
6.6 Pulling Range	15
6.7 Transponder Turn Off	16
SECTION 7.0 - COMPUTING COUNTER SETUP PROCEDURES	17
7.1 Receiver Sensitivity and Bandwidth Measurements	17
7.2 Frequency Error Measurements	17
7.3 Delay and Delay Jitter Measurements	18
7.4 Pulse Width and Pulse Width Jitter Measurements	19
SECTION 8.0 - COMPUTING COUNTER PROGRAMS	20
8.1 Precision Time Interval Standard Deviation	20
8.2 Variate Difference	22
8.3 Average of "N" Measurements	23
SECTION 9.0 - ABBREVIATIONS	25

## 1.0 SCOPE

1.1 This document contains the test procedures necessary for the calibration and performance verification of the coherent C-band transponder after spacecraft hardware integration, but prior to spacecraft/launch vehicle integration.

1.2 The tests described herein are to be performed as required by the Acceptance Test Plan for GEOS-C, APL/JHU Document 7234-9057.

## 2.0 CLASSIFICATION OF TESTS

### 2.1 Electrical Performance Test

This test or applicable portions thereof are to be performed whenever the transponder is hardlined to the C-Band Test Console. This test is designed to provide calibration data and detailed performance evaluation of the transponder.

### 2.2 Airlink Test

This test shall be performed whenever hardline is not available to the transponder. It is designed for a quick look at the unit to assure that there have been no significant changes in the established performance parameters.

## 3.0 RECORD OF TEST

3.1 All test data shall be recorded in permanent form on the approved data sheets.

## 4.0 C-BAND TEST CONSOLE

4.1 Equipment Supplied - Listed below by name, manufacturer, and model number are the items used in the C-Band Test Console.

- (1) Electronic Counter, HP5223L
- (2) Pulse Generator, Data Pulse 101 (2 each)
- (3) Synthesizer Driver, HP5110B
- (4) Frequency Synthesizer, HP5105A (2 each)
- (5) Frequency Multiplier Assembly, NASA
- (6) Modulator, HP8403A/8733B
- (7) Fine Line Receiver, NASA
- (8) Computing Counter, HP5360A/5379A/5375A
- (9) Oscilloscope, Tektronix R7603/7A12/7A15A/7B53A
- (10) Power Meter, HP432A/478A
- (11) AC Voltmeter, HP400FL
- (12) Wavemeter, FXR H410A
- (13) Attenuator, Step, Narda 704-99
- (14) Attenuator, Variable, Merrimac AU-26A
- (15) Attenuator, Variable, Merrimac AU-46A
- (16) Attenuator, Variable, Merrimac AR-1 (2 each)
- (17) Attenuator, 10 db, Tektronix 011-0085-00
- (18) Attenuator, 6 db, Tektronix 011-0069-01
- (19) Attenuator, 3 db, Narda 757-3
- (20) Feed through Termination, 50 ohms, Tektronix 011-0049-01
- (21) Feed through Termination, 93 ohms, Tektronix 011-0056-00  
(2 each)
- (22) Directional Coupler, 30 db, Narda 3004-30
- (23) Directional Coupler, 20 db, Microlab/FXR CB-78N
- (24) Directional Coupler, 10 db, Microlab/FRX CB-77N
- (25) Digital Voltmeter, Data Precision 2440

(26) Isolator, Addington Labs., 101702357 (2 each)

(27) Circulator, Addington Labs., 100101676

(28) Crystal Detector, Aertech D408BR-1 (2 each)

4.2 Test Setup - The C-Band Test Console shall be connected as shown in Figure 1 and as described herein.

4.3 Functional Controls - The following functions are controlled by the equipment as described below:

<u>Function</u>	<u>Control</u>
PRF	PULSE GENERATOR NO. 1, Repetition Rate Control.
Code Spacing	PULSE GENERATOR NO. 1, Delay Control.
Pulse Width	PULSE GENERATOR NO. 1, Width Control.
Signal Level	STEP ATTEN
RX Gate	PULSE GENERATOR NO. 2, Delay Control.

4.4 Initial Conditions

The following conditions shall be set before any test.

STEP ATTEN	90 db
A2	Maximum
PIN MCD	EXT PULSE
TX SYNTH	474.1666667 MHz
RX SYNTH	476.6750000 MHz
PRF	160 pps
PULSE WIDTH	0.5 microsecond

PULSE CODE	DOUBLE PULSE, 8.0 microseconds spacing, leading edge to leading edge.
OSCILLOSCOPE	LV mode, ALT, 2 v/div.; EXT TRIG, 2 usec/div.; display TX PULSE waveform on upper trace at 4 volts peak amplitude.

#### 4.5 C-Band Test Console Calibration Procedures

##### 4.5.1 Initial Setup

- (a) Set the test set to the INITIAL CONDITIONS defined in 4.4.
- (b) Disconnect the antenna cable at the output of the 20 db directional coupler.
- (c) Set PULSE GEN NO. 1 to SINGLE PULSE.
- (d) Set STEP ATTEN to 0 db.
- (e) Set PRF to 640 pps.
- (f) Adjust A3 for TX PULSE amplitude equal to 4 volts peak.

##### 4.5.2 Signal Level Calibration

- (a) Record the ATTENUATION in the cable that connects the 20 db directional coupler output and the transponder antenna terminal.
- (b) Connect the power meter to the 20 db directional coupler output.

- (c) Zero the power meter on the minimum scale needed to read 0 dbm plus the ATTENUATION recorded in 4.5.2 (a). If the aforementioned value exceeds +10 dbm, insert a 10 db pad.
- (d) Set the PIN MOD to AM.
- (e) Adjust A1 for a power meter reading of 0 dbm plus the ATTENUATION measured in 4.5.2 (a). Record the power output (PWR CAL) at the 20 db directional coupler. Record the dial setting of A1.
- (f) Calculate  $PWR SET = PWR CAL - \text{ATTENUATION}$  measured in 4.5.2 (a). Record PWR SET.
- (g) Set the PIN MOD to EXT PULSE.
- (h) Disconnect the power meter from the 20 db directional coupler output and reconnect it as shown in Figure 1.

#### 4.5.3 Delay Calibration

- (a) Record the time delay of the cable connecting the 20 db directional coupler output and the transponder antenna terminal.
- (b) Set A2 to a dial reading of 150.
- (c) Adjust A4 for a RX PULSE amplitude equal to 4 volts peak.
- (d) Connect the COMP COUNT as described in 7.3.
- (e) Enter the precision time interval standard deviation program described in 8.1.
- (f) Measure, compute, and record the reference delay and delay jitter.

#### 4.5.4 Frequency Stability Reference Measurement

- (a) With the PRF remaining at 640 pps, connect the FLR output to the COMP COUNT as described in 7.2.
- (b) Connect a parallel output from the FLR to the oscilloscope as shown in Figure 1. Set the oscilloscope as follows: RV mode, 200 mv/div.; INT TRIG, 5 usec/div.
- (c) Adjust the RX GATE for the maximum amplitude of the 100 KHz sine wave.
- (d) Adjust A2 for an amplitude equal to 1.2 volts peak to peak.
- (e) Enter the Variate Difference Program described in 8.2.
- (f) Compute the standard deviation of the frequency measurement. Record the average of at least three readings.
- (g) Set the PRF to 160 pps.
- (h) Adjust A2 for an amplitude equal to 400 mv peak to peak.
- (i) Compute the standard deviation of the frequency measurement. Record the average of at least three readings.

#### 4.5.5 Interline Noise Reference Measurement

- (a) With the test set unchanged from the previous test, disconnect the oscilloscope from the FLR output and connect that same output to the ACVM.

- (b) Offset the LO SYNTH to the frequency steps listed below; measure and record the average amplitude (db) on the ACVM at each step: 0, 1.4, 3.3, 6.7, 10.0, 11.9 and 13.3 Hz.
- (c) Restore the test set to the INITIAL CONDITIONS defined in 4.4.
- (d) Reconnect the antenna cable to the output of the 20 db directional coupler.

## 5.0 ELECTRICAL PERFORMANCE TEST

### 5.1 Transponder Turn On

5.1.1 Set A2 to maximum.

5.1.2 Set STEP ATTEN to 90 db.

5.1.3 Set PULSE GEN NO. 1 to SINGLE PULSE.

5.1.4 Set PRF to 160 pps.

\*SC 5.1.5 Send coherent transponder ON command. Verify command.

\*\*CRT 5.1.6 Measure and record the following TM functions: input voltage and current, SS, PRF, PWR, LO, FIL AND BPT.

5.1.7 Set STEP ATTEN for a -30 dbm signal level (PWR SET - STEP ATTEN = -30 dbm).

5.1.8 Interrogate the transponder by setting PULSE GEN NO. 1 to DOUBLE PULSE. With a stop watch measure the time from initial interrogation to when the transponder first replies as indicated by the power meter. Record the turn on time delay.

\*Denotes requirement for spacecraft action.

\*\*Denotes use of CRT display.



5.1.9 Adjust A2 for an RX pulse amplitude equal to 4 volts peak. Record the dial setting of A2.

## 5.2 TM Functions Vs. PRF

5.2.1 Measure and record the TM functions (input voltage and current, SS, PRF, PWR, LO, FIL & BPT at the following PRF's: 160, 320, 480, 640, 960, 1280, and 2560 pps.

## 5.3 Receiver Sensitivity at 5690 MHz

5.3.1 Set the PRF to 1000 pps.

5.3.2 Connect the COMP COUNT as described in 7.1.

5.3.3 Increase the STEP ATTEN until the COMP COUNT reads 990 pps. Record the STEP ATTEN setting. Calculate the receiver sensitivity by adding PWR SET to the STEP ATTEN setting.

## 5.4 Receiver Bandwidth

5.4.1 With the test setup unchanged from 5.3.3, decrease the STEP ATTEN by 3 db.

5.4.2 Increase the TX SYNTH frequency in 50 KHz steps until the COMP COUNT reads 990 pps. Calculate the upper 3 db frequency by multiplying the TX SYNTH frequency by twelve. Record the upper 3 db frequency.

5.4.3 Decrease the TX SYNTH frequency in 50 KHz steps until the COMP COUNT reads 990 pps. Calculate the lower 3 db frequency by multiplying the TX SYNTH frequency by twelve. Record the lower 3 db frequency.

5.4.4 Calculate the receiver bandwidth by subtracting the lower 3 db frequency from the upper 3 db frequency. Record the receiver bandwidth.

5.4.5 Calculate the receiver center frequency by adding the upper and lower 3 db frequencies and dividing their sum by two. Record the receiver center frequency.

#### 5.5 Receiver Code Spacing

5.5.1 Set the TX SYNTH to 474.1666667 MHz.

5.5.2 Set the STEP ATTEN for -30 dbm (PWR SET - STEP ATTEN = -30 dbm).

5.5.3 Observe the TX waveform on the oscilloscope at a one usec/div sweep speed. Observe the transponder replies on the power meter.

5.5.4 Increase the delay control of PULSE GEN NO. 1 until the transponder begins to count down. Measure and record to 0.1 usec resolution the code spacing for full firing (upper code accept) and the code spacing for no firing (upper code reject).

5.5.5 Decrease the delay control of PULSE GEN NO. 1 until the transponder begins to count down. Measure and record to 0.1 usec resolution the code spacing for full firing (lower code) accept and the code spacing for no firing (lower code reject).

5.5.6 Reset the delay control of PULSE GEN NO. 1 for an 8.0 usec code spacing, and reset the oscilloscope sweep speed to 2 usec/div.

## 5.6 Peak Power Output

5.6.1 Set the PRF to 640 pps.

5.6.2 Zero the power meter.

\*\*CRT 5.6.3 Measure and record the PRF, the power meter reading (dbm), and the following TM functions: PRF, PWR, and BPT.

5.6.4 After measurement of the pulse width in the next test, calculate the peak power from the formula

$$\text{Peak Power} = \frac{\text{Average PWR X ATTEN}}{\text{PRF X PULSE WIDTH}}$$

## 5.7 Transmitter Pulse Width and Pulse Width Jitter

5.7.1 Connect the COMP COUNT as described in 7.4.

5.7.2 Enter the Precision Time Interval Standard Deviation Program as described in 8.1

5.7.3 Adjust A2 and A4 for an RX PULSE amplitude of 4 volts peak.

5.7.4 Measure and record the pulse width and the pulse width jitter.

## 5.8 Delay and Delay Jitter Vs. Receiver Signal Level

5.8.1 Set the PRF to 640 pps.

5.8.2 Connect the COMP COUNT as described in 7.3.

5.8.3 Use the program entered in 5.7.2.

5.8.4 Adjust the TX PULSE and RX PULSE waveforms for 4 volts peak.

\*\*CRT 5.8.5 Measure and record input voltage and BPT at the beginning and end of this test.

\*\*CRT 5.8.6 Using the STEP ATTEN as the variable, measure and record the STEP ATTEN setting, SS TM voltage, delay and delay jitter at the following signal levels: -20, -25, -30, -35, -40, -45, -50, -55, and -60 dbm. (Signal Level = PWR SET minus STEP ATTEN).

5.8.7 Repeat 5.8.2 through 5.8.6 at PRF's of 160, 320, and 960 pps and at the following signal levels: -20, -30, -40, and -60 dbm.

## 5.9 Frequency Error

5.9.1 Set the PRF to 640 pps.

5.9.2 Set the STEP ATTEN for a -30 dbm signal level.

5.9.3 Connect the FLR output to the COMP COUNT as described in 7.2.

5.9.4 Connect a parallel output from the FLR to the oscilloscope as shown in Figure 1. Set the oscilloscope as follows: RV mode, 200 mv/div; INT TRIG, 5 usec/div.

5.9.5 Adjust the RX GATE for maximum amplitude of the 100 KHz sine wave.

5.9.6 Adjust A2 for an amplitude of 1.2 volts peak-to-peak.

5.9.7 Enter the Variate Difference Program described in 8.2.

5.9.8 Compute the standard deviation of the frequency measurement. Record the average of at least three readings.

5.9.9 Set the PRF to 160 pps.

5.9.10 Adjust A2 for an amplitude of 400 mv peak-to-peak.

5.9.11 Repeat 5.9.8.

### 5.10 Pulling Range

- 5.10.1 With the test set unchanged from the previous test, disconnect the oscilloscope from the FLR and connect that FLR output to the ACVM and record the amplitude.
- 5.10.2 Increase the TX SYNTH and LO SYNTH simultaneously in 10 KHz steps until the ACVM reading drops 2 db. Calculate the upper lock frequency by multiplying the TX SYNTH frequency by twelve. Record the upper lock frequency.
- 5.10.3 Decrease the TX SYNTH and LO SYNTH simultaneously in 10 KHz steps until the ACVM reading drops 2db below the reading from 5.10.1. Calculate the lower lock frequency by multiplying the TX SYNTH frequency by twelve. Record the lower lock frequency.
- 5.10.4 Reset the TX SYNTH to 474.1666667 MHz.
- 5.10.5 Reset the LO SYNTH to 476.6750000 MHz.

### 5.11 Interline Noise

- 5.11.1 With the test set unchanged from the end of the previous test, offset the LO SYNTH to the frequency steps listed below; measure and record the average amplitude (db) on the ACVM at each step: 0, 1.4, 3.3, 6.7, 10.0, 11.9, and 13.3 Hz.

### 5.12 Transponder Turn Off

- \*\*CRT 5.12.1 Measure and record the following TM functions: input voltage and current, SS, PRF, PWR, LO, FIL, and BPT.

**\*\*CRT 5.12.2** Turn off the interrogate signal by setting PULSE

GEN NO. 1 to single pulse. Time the turn-off delay with a stop watch by counting the time from interrogate signal off to when the input current drops to the standby level. Record turn off delay.

**\*\*CRT 5.12.3** Measure and record the following TM functions: input voltage and current, SS, PRF, PWR, LO, FIL, and BPT.

**\*S/C 5.12.4** Send coherent transponder OFF command. Verify command.

## 6.0 AIRLINK TEST

### 6.1 Transponder Turn On

6.1.1 Set the test set to the INITIAL CONDITIONS defined in 4.5, except for the PRF which shall be set to 640 pps.

**\*S/C 6.1.2** Send the coherent transponder ON command. Verify command.

**\*S/C 6.1.3** Send the coherent transponder OVERRIDE ON command. Verify command.

6.1.4 After approximately 40 seconds, decrease STEP ATTEN until the transponder begins to reply.

6.1.5 Using STEP ATTEN and A1 set the signal level to 40 db above threshold. If 40 db is not attainable, set STEP ATTEN and A1 to 0 db.

6.1.6 Adjust A2 for an RX PULSE amplitude equal to 4 volts peak.

**\*\*CRT 6.1.7** Measure and record the following TM functions: input voltage and current, SS, PRF, PWR, LO FIL, and BPT.

### 6.2 Receiver Code Spacing

6.2.1 Observe the TX PULSE waveform on the oscilloscope at a 1 usec/div sweep speed.

- 6.2.2 Observe the reply PRF by connecting the RX PULSE waveform to the COMP COUNT as defined in 7.1.
  - 6.2.3 Increase the delay control of PULSE GEN NO. 1 until the transponder begins to count down. Measure and record to 0.1 usec resolution the code spacing for full firing (upper code accept) and the code spacing for no firing (upper code reject).
  - 6.2.4 Decrease the delay control of PULSE GEN NO. 1 until the transponder begins to count down. Measure and record to 0.1 usec resolution the code spacing for full firing (lower code accept) and the code spacing for no firing (lower code reject).
  - 6.2.5 Reset the delay control of PULSE GEN NO. 1 for an 8.0 usec code spacing and reset the oscilloscope sweep speed to 2 usec/div.
- 6.3 Transmitter Pulse Width
    - 6.3.1 Connect the COMP COUNT as described in 7.4.
    - 6.3.2 Enter the Average of "N" Measurements Program as described in 8.3.
    - \*\*CRT 6.3.3 Measure and record the pulse width and the following TM functions: PRF, PWR, and BPT.
  - 6.4 Delay Vs. Relative Signal Level
    - 6.4.1 Connect the COMP COUNT as described in 7.3.
    - 6.4.2 Use the program entered in 6.3.2.
    - \*\*CRT 6.4.3 Measure and record the input voltage and BPT at the beginning and end of this test.

**\*\*CRT 6.4.4** Measure and record the STEP ATTEN setting, SS TM voltage and delay.

6.4.5 Increase the STEP ATTEN in 5 db steps and repeat the measurements of 6.4.4 at each step for a maximum of five steps or until threshold is reached.

6.4.6 Reset the STEP ATTEN to its position at the beginning of this test.

## 6.5 Frequency Error

6.5.1 Connect the FLR output to the COMP COUNT as described in 7.2.

6.5.2 Connect a parallel output from the FLR to the oscilloscope as shown in Figure 1. Set the oscilloscope as follows: RV mode, 200 mv/div; INT TRIG, 5 usec/div.

6.5.3 Adjust the RX GATE for maximum amplitude of the 100 KHz sine wave.

6.5.4 Adjust A2 for an amplitude of 1.2 volts peak-to-peak.

6.5.5 Enter the Variate Difference Program described in 8.2.

6.5.6 Compute the standard deviation of the frequency measurement. Record the average of at least three readings.

6.5.7 Set the PRF to 160 pps.

6.5.8 Adjust A2 for an amplitude of 400 mv peak-to-peak.

6.5.9 Repeat 6.5.6.

## 6.6 Pulling Range

6.6.1 With the test set unchanged from the previous test, disconnect the oscilloscope from the FLR and connect the FLR output to the ACVM record the amplitude.



6.6.2 Increase the TX SYNTH and LO SYNTH simultaneously in 10 KHz steps until the ACVM reading drops 2 db. Calculate the upper lock frequency by multiplying the TX SYNTH frequency by twelve. Record the upper lock frequency.

6.6.3 Decrease the TX SYNTH and LO SYNTH simultaneously in 10 KHz steps until the ACVM reading drops 2 db below the reading from 6.6.1. Calculate the lower lock frequency by multiplying the TX SYNTH frequency by twelve. Record the lower lock frequency.

6.6.4 Reset TX SYNTH to 474.1666667 MHz.

6.6.5 Reset LO SYNTH to 476.6750000 MHz.

#### 6.7 Transponder Turn Off

\*\*CRT 6.7.1 Measure and record the following TM functions: input voltage and current, SS, PRF, PWR, LO, FIL, and BPT.

6.7.2 Set STEP ATTEN to 90 db.

\*S/C 6.7.3 Send coherent transponder OVERRIDE OFF command. Verify command.

\*S/C 6.7.4 Send coherent transponder OFF command. Verify command.

## 7.0 COMPUTING COUNTER SET UP PROCEDURES

### 7.1 Receiver Sensitivity and Bandwidth Measurements

7.1.1 Input: RX PULSE into Channel A.

7.1.2 Counter Controls:

- (a) Cycle Rate Switch: MAX
- (b) Digits Displayed: 4
- (c) Mode: MODULE
- (d) Measurement Time: 1 sec
- (e) Multiplier: 1

7.1.3 Input Module Controls

- (a) Function: Frequency
- (b) Input: A
- (c) Level: as necessary
- (d) Sensitivity Multiplier: X1
- (e) Coupling: AC

7.1.4 The Internal Controls - NA

### 7.2 Frequency Error Measurements

7.2.1 Input: 100 KHz output from FLR into Channel B.

7.2.2 Counter Controls

- (a) Cycle Rate Switch: MAX
- (b) Digits Displayed: 8
- (c) Mode: MODULE
- (d) Measurement Time: 100 msec
- (e) Multiplier: 1

### 7.2.3 Input Module Controls

- (a) Function: Frequency
- (b) Input: B
- (c) Level: Preset
- (d) Sensitivity Multiplier: X10

### 7.2.4 Time Interval Controls - NA

## 7.3 Delay and Delay Jitter Measurements

### 7.3.1 Input

- (a) TX PULSE into T1
- (b) RX PULSE into T2

### 7.3.2 Counter Controls

- (a) Cycle Rate Switch: MAX
- (b) Digits Displayed: 5
- (c) Mode: PLUG-IN

### 7.3.3 Input Module Controls - NA

### 7.3.4 Time Interval Controls

- (a) T1 Slope: ↑
- (b) T2 Slope: ↑
- (c) Arming: T1 ↓
- (d) Level Multiplier: X1 (T1 and T2)
- (e) T1 Level: +2.00 volts
- (f) T2 Level: Adjusted for Zero Reading with TX Pulse  
Input on COM.
- (g) SEP/COM Switch: SEP

#### 7.4 Pulse Width and Pulse Width Jitter Measurements

7.4.1 Input: RX PULSE into COM

7.4.2 Counter Controls

(a) Cycle Rate Switch: MAX

(b) Digits Displayed: 4

(c) Mode: PLUG-IN

7.4.3 Input Module Controls - NA

7.4.4 Time Interval Controls

(a) T1 Slope: ↑

(b) T2 Slope: ↓

(c) Arming: T1 ↓

(d) Level Multiplier: X1 (T1 and T2)

(e) T1 Level: +2.00 volts

(f) T2 Level: Adjust for Zero Reading with T2 Slope ↑

(g) SEP/COM Switch: COM

ORIGINAL PAGE IS  
OF POOR QUALITY

8.0 COMPUTING COUNTER PROGRAMS

8.1 Precision Time-Interval Standard Deviation

8.1.1 Description: This program computes the mean and standard deviation of the time interval measurements performed by the HP5360A with the 5379A plug-in.

8.1.2 Measurement Setup

(a) Counter/Plug-In Controls - See Paragraphs 7.3 and 7.4.

(b) Keyboard

(1) Repeat Loop Switch: 1K

(2) Pause Switches: DISPLAY and HALT

(3) Main/Subswitch: NORMAL

(c) DISPLAY: The counter should measure and display the desired parameter before the program is entered.

## 8.1.3 Program Entry

(a) Counter Controls: Press EXT

(b) Keyboard Controls

- |                             |                             |
|-----------------------------|-----------------------------|
| (1) LEARN                   | (21) $\div$                 |
| (2) CLEAR X                 | (22) XFER PROG              |
| (3) A $\leftrightarrow$ X   | (23) A $\leftrightarrow$ X  |
| (4) CLEAR X                 | (24) $\overrightarrow{AXY}$ |
| (5) B $\leftrightarrow$ X   | (25) X                      |
| (6) XFER PROG               | (26) B $\leftrightarrow$ X  |
| (7) PLUG IN                 | (27) $\overrightarrow{BXY}$ |
| (8) DISPLAY X               | (28) -                      |
| (9) 10X                     | (29) 3                      |
| (10) A $\leftrightarrow$ X  | (30) $\overrightarrow{NXY}$ |
| (11) $\overrightarrow{AXY}$ | (31) $\div$                 |
| (12) +                      | (32) 7                      |
| (13) A $\leftrightarrow$ X  | (33) $\sqrt{X}$             |
| (14) X                      | (34) X/10                   |
| (15) $\overrightarrow{BXY}$ | (35) PAUSE                  |
| (16) +                      | (36) RUN                    |
| (17) B $\leftrightarrow$ X  |                             |
| (18) REPEAT                 |                             |
| (19) $\overrightarrow{AXY}$ |                             |
| (20) $\overrightarrow{NXY}$ |                             |

#### 8.1.4 Program Operation

- (a) Press START: The program will run until N samples have been entered.
- (b) STOP & DISPLAY: The program will stop and display the standard deviation.
- (c) Press:
  - (1) AXY
  - (2) X/10
- (d) DISPLAY: Mean or Average
- (e) Press START: Recycles program

#### 8.2 Variate Difference

8.2.1 Description - This program computes the rms frequency deviation of frequency measurements performed by the HP5360A.

#### 8.2.2 Measurement Setup

- (a) Counter/Input Module - See Paragraph 7.2.
- (b) Keyboard
  - (1) Repeat Loop Switch: 100
  - (2) Pause Switches: NA
  - (3) Main/Subswitch: NORMAL
- (c) DISPLAY: The counter should measure and display the frequency input to the counter before the program is entered.

### 8.2.3 Program Entry

(a) Counter Controls - Press EXT

(b) Keyboard Controls

- |                             |                             |
|-----------------------------|-----------------------------|
| (1) LEARN                   | (15) $B \leftrightarrow X$  |
| (2) CLEAR X                 | (16) REPEAT                 |
| (3) $B \leftrightarrow X$   | (17) $\overrightarrow{NXY}$ |
| (4) MODULE B                | (18) $\overrightarrow{XY}$  |
| (5) $A \leftrightarrow X$   | (19) +                      |
| (6) XFER PROG               | (20) XFER PROG              |
| (7) MODULE B                | (21) $\overrightarrow{BXY}$ |
| (8) $A \leftrightarrow X$   | (22) $Y \leftrightarrow X$  |
| (9) $\overrightarrow{AXY}$  | (23) $\div$                 |
| (10) -                      | (24) 7                      |
| (11) $\overrightarrow{XY}$  | (25) $\sqrt{X}$             |
| (12) X                      | (26) DISPLAY X              |
| (13) $\overrightarrow{BXY}$ | (27) RUN                    |
| (14) +                      |                             |

### 8.2.4 Program Operation

(a) Press START

(b) Running DISPLAY: Standard deviation of frequency measurement.

## 8.3 Average of "N" Measurements

8.3.1 Description - This program computes the average of N (as determined by the Repeat Loop Switch) frequency or time interval measurements performed by the HP5360A.



### 8.3.2 Measurement Setup

(a) Counter/Input Module/Plug-In - See appropriate Paragraph in Section 7.

(b) Keyboard

(1) Repeat Loop Switch: As desired

(2) Pause Switches: NA

(3) Main/Subswitch: NORMAL

(c) DISPLAY: The counter should measure and display the desired input before the program is entered.

### 8.3.3 Program Entry

(a) Counter Controls - Press EXT

(b) Keyboard Controls

(1) LEARN

(9) REPEAT

(2) CLEAR X

(10) XFER PROG

(3) A  $\rightleftarrows$  X

(11)  $\overrightarrow{AXY}$

(4) XFER PROG

(12)  $\overrightarrow{NXY}$

(5) PLUG IN (OR MODULE)

(13)  $\div$

(6)  $\overrightarrow{AXY}$

(14) DISPLAY X

(7) +

(15) RUN

(8) A  $\rightleftarrows$  X

### 8.3.4 Program Operation

(a) Press START

(b) Running DISPLAY: Average of "N" measurements.

## 9.0 ABBREVIATIONS

A	Attenuator (also ATTEN)
ACVM	AC Voltmeter
ALT	Alternate
BPT	Base Plate Temperature
CH	Channel
COMP COUNT	Computing Counter
db	Decibel(s)
dbm	Decibels referenced to one milliwatt
div	Division
EXT	External
FIL	Filament
FLR	Fine Line Receiver
FREQ	Frequency
GEN	Generator
H	Horizontal (Oscilloscope Plug-In)
Hz	Hertz
INT	Internal
KHz	Kilohertz
LO	Local Oscillator
LV	Left Vertical (Oscilloscope Plug-In)
MHz	Megahertz
MOD	Modulator
msec	Millisecond
MULT	Multiplier

mv	millivolt
NA	Not Applicable
nsec	nanosecond
pps	pulses per second
PRF	Pulse Repetition Frequency
PWR	Power
rms	root mean square
RV	Right Vertical (Oscilloscope Plug-In)
RX	Receiver
sec	second
SS	Signal Strength
SYNTH	Synthesizer
TM	Telemetry
TRIG	Trigger
TX	Transmitter
usec	Microsecond
v	Volt

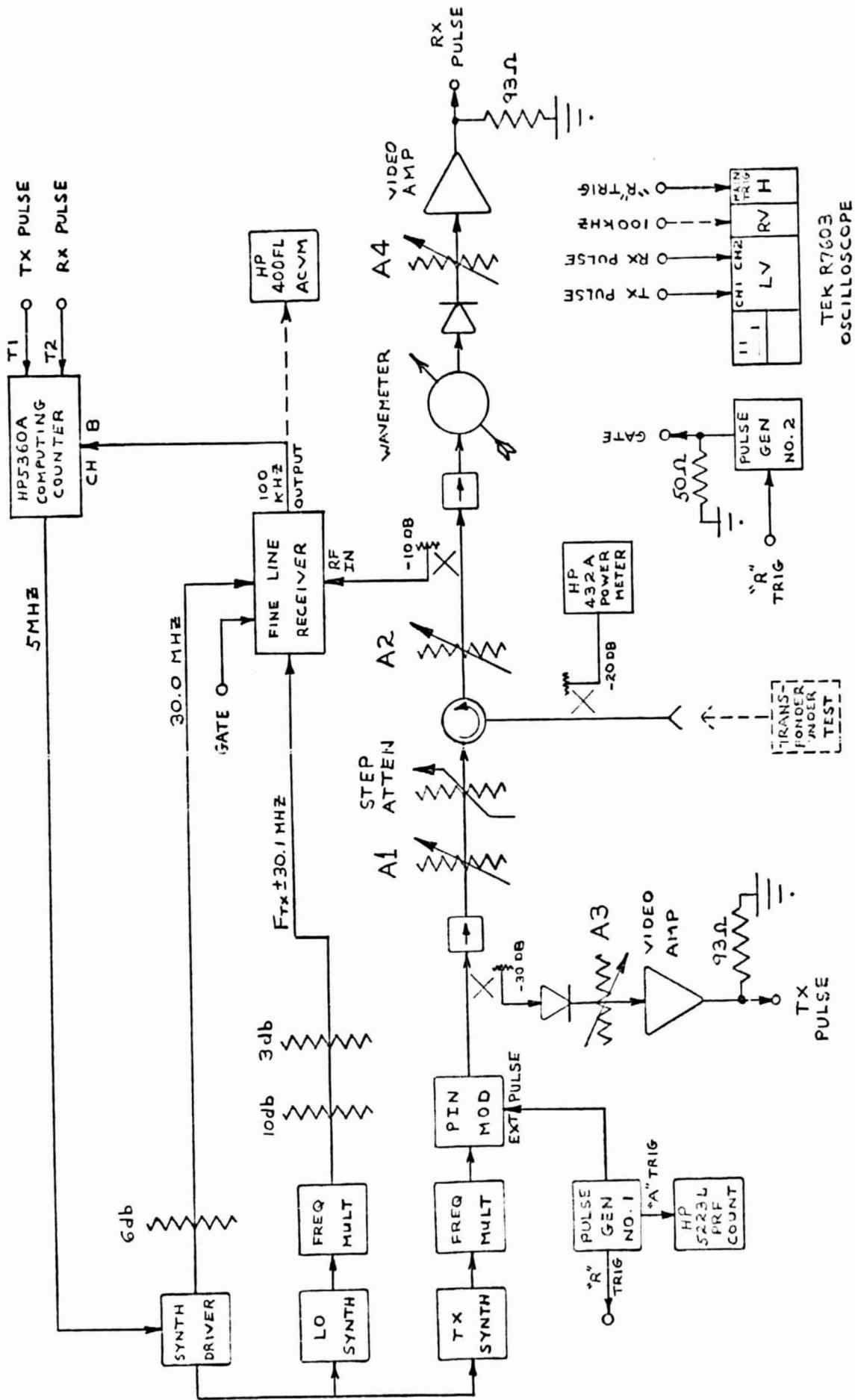

FIGURE 1

C-Band Test Console, Block Diagram,  
Spacecraft Level Tests