

NASA SP-5976 (03)

January 1976

TECHNOLOGY UTILIZATION

CASE FILE
COPY

FLUID HANDLING EQUIPMENT

A COMPILATION



NATIONAL AERONAUTICS AND SPACE ADMINISTRATION

Foreword

The National Aeronautics and Space Administration has established a Technology Utilization Program for the dissemination of information on technological developments which have potential utility outside the aerospace community. By encouraging multiple application of the results of its research and development, NASA earns for the public an increased return on the investment in aerospace research and development programs.

This document is one in a series intended to furnish such technological information. It contains three sections describing devices and techniques used in fluid-handling and vacuum systems. Section 1 presents several articles on fluid lines and tubing. Section 2 describes a number of components such as valves, filters, and regulators. The last section contains descriptions of a number of innovative fluid-handling systems.

Additional technical information on the articles in this Compilation can be requested by circling the appropriate number on the Reader Service Card included in this Compilation.

The latest patent information available at the final preparation of this Compilation is presented on the page following the last article in the text. For those innovations on which NASA has decided not to apply for a patent, a Patent Statement is not included. Potential users of items described herein should consult the cognizant organization for updated patent information at that time.

We appreciate comment by readers and welcome hearing about the relevance and utility of the information in this Compilation.

*Technology Utilization Office
National Aeronautics and Space Administration*

NOTICE● This document was prepared under the sponsorship of the National Aeronautics and Space Administration. Neither the United States Government nor any person acting on behalf of the United States Government assumes any liability resulting from the use of the information contained in this document, or warrants that such use will be free from privately owned rights.

For sale by the National Technical Information Service, Springfield, Virginia 22161

Contents

	Page
SECTION 1. FLUID LINES	
Flexible-Line Insulation Technique	1
Flexible Hose Guide for Multiplane Kinematics	2
Break-Resistant Flexible Hose	4
Tube Cutter	5
Tube-Twist Prevention	6
SECTION 2. FILTERS, VALVES, REGULATORS, AND OTHER FITTINGS	
Chatter-Free Check Valve: A Concept	7
Cartridge Filter: A Concept	8
Pipefitting With 360° Rotation	9
Metal-to-Plastic Tubing Connector	10
Pressure Regulator	12
Replaceable Filters and Cones for Flared-Tubing Connectors	13
Remote-Controlled Quick Disconnect for Fluid Lines	14
Indicator Light With Three-Way Latching Solenoid Valve	15
Transpiration Seal	16
Modifications to a Vacuum-Assisted Filtering Device to Minimize Contamination	17
Modified Coupling Provides Low-Temperature, Vacuum-Tight Seal	18
Balance-Type, Adjustable, Cryogenic Back-Pressure Regulator	19
Device for Pretesting Poppet Valves	20
SECTION 3. FLUID ASSEMBLIES AND EQUIPMENT	
Rectangular Concentric-Tube Injector	21
Support of Fluid-Assembly Components	22
Automatic Vacuum-Cycling Apparatus for Cleaning Bourdon-Tube Gauges	23
Dynamics of a Flexible Bulkhead and Contained Fluid	24
Air Diffuser Assembly	24
Lightweight Transfer Unit for Potable Water	24
PATENT INFORMATION	25

Section 1. Fluid Lines

FLEXIBLE-LINE INSULATION TECHNIQUE

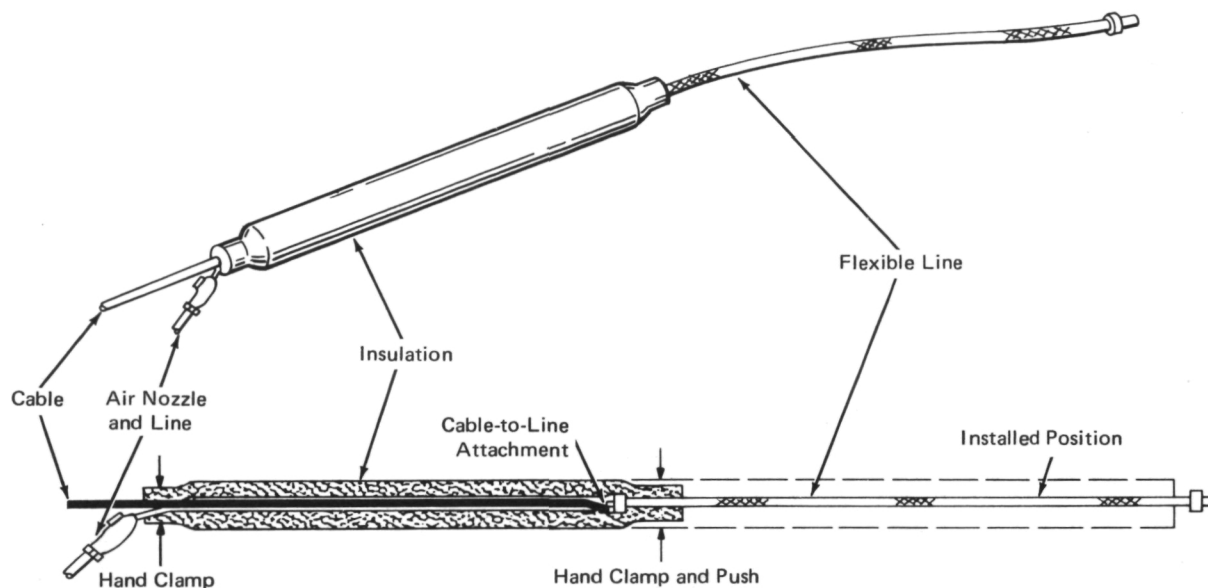

Flexible-Line Insulation Assembly

Resilient insulation may have to be fitted over long, curved lengths of flexible lines or pipes by slitting the insulation, wrapping it around the lines, and resealing it. In a faster and neater process, the insulation is expanded with compressed air to allow it to be pushed along over the lines (see figure).

A thin cable is attached to a flexible line to be insulated, and the line is secured at one end. An operator hand-squeezes the insulation along the thin cable until a short section is forced over the flexible line. An airhose is inserted under the insulation, and the ends of the insulation are squeezed airtight by two operators. The compressed air inflates the insulation,

which then is pushed or pulled along by both operators until the flexible line is covered. When the insulation process is finished, the air is shut off and the nozzle is removed.

Source: L. L. Tempest and
C. L. Calvert of
The Boeing Company
under contract to
Kennedy Space Center
(KSC-10738)

Circle 1 on Reader Service Card.

FLEXIBLE HOSE GUIDE FOR MULTIPLANE KINEMATICS

A guide enables a flexible hose to bend, move, and operate in more than one plane without twisting, thus giving the hose a longer service life. In the past, flexible hose has been constrained to motion in one plane. Any other out-of-plane motion has been restricted, because the hose must not be allowed to twist.

The guide has proved successful under strenuous conditions. The basic concept consists of two independent bends (see Figure 1); one is curved in a

horizontal plane, and the other is curved in a vertical plane. The guide provides a neutral length of hose separating the bends and preventing interaction between them.

Determination of the minimal neutral distance needed for proper operations led to the identification of a single theoretical inflection point, where the hose becomes free of the guide. A roller, for each hose in the

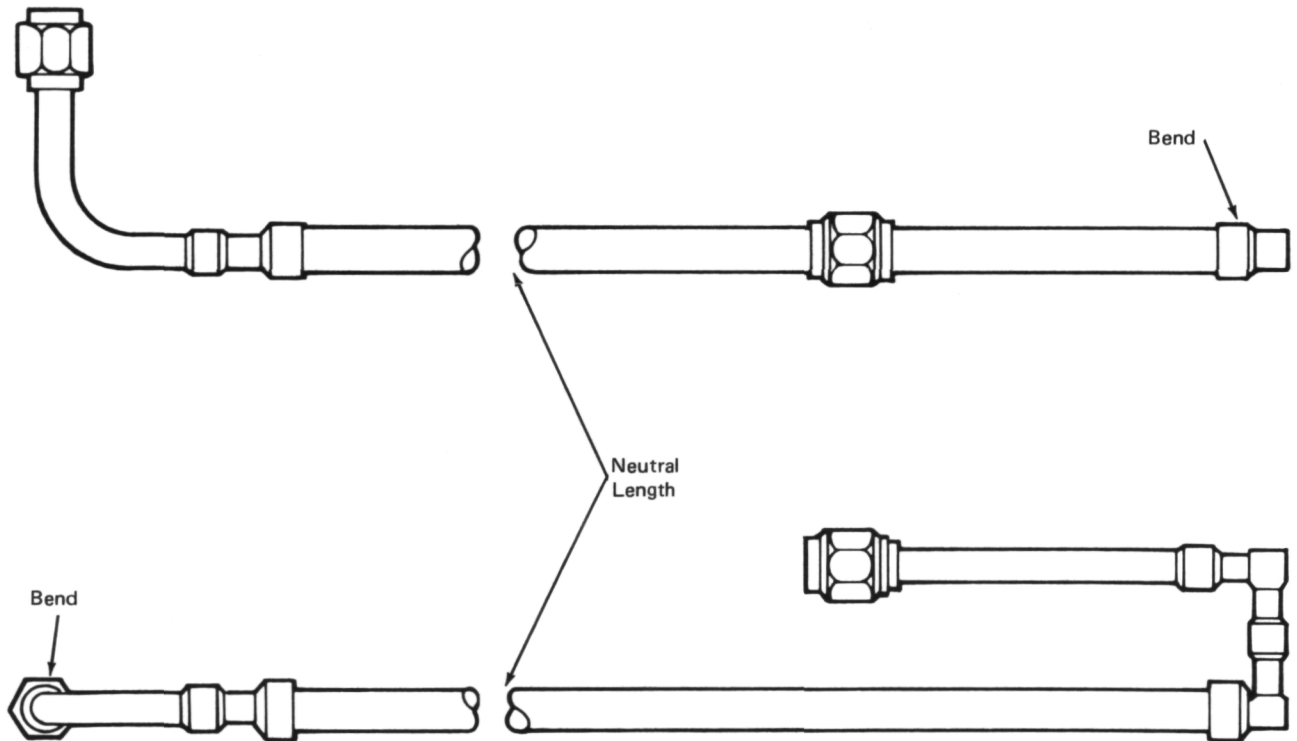

Figure 1. Break-Resistant Hose: Two Views

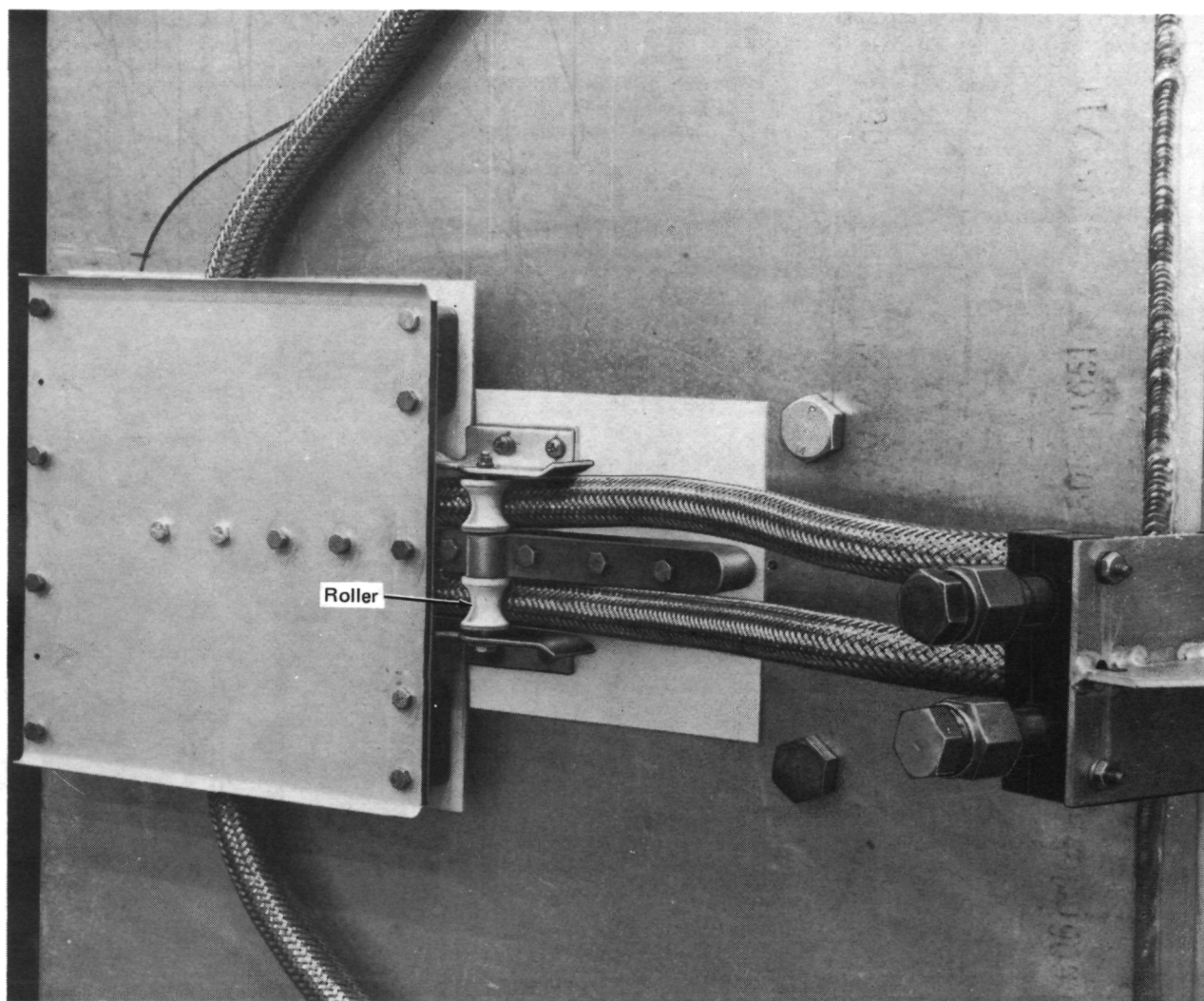

Figure 2. Flexible Hose Installed

assembly, is placed at this point (Figure 2). The inherent stiffness of the hose makes this point the inflection point between the horizontal and vertical bends. Each bend is a pure single-plane curve with no component of rotation or twist along the axis of the hose. The arrangement can be modified for other motions of the hose.

Source: E. A. French and H. George of
Rockwell International Corp.
under contract to
Johnson Space Center
(MSC-17158)

Circle 2 on Reader Service Card.

BREAK-RESISTANT FLEXIBLE HOSE

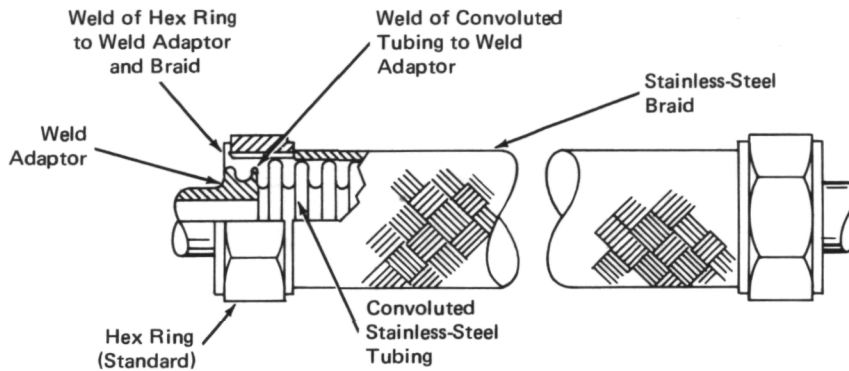

Figure 1. Standard Flexible Metal Hose

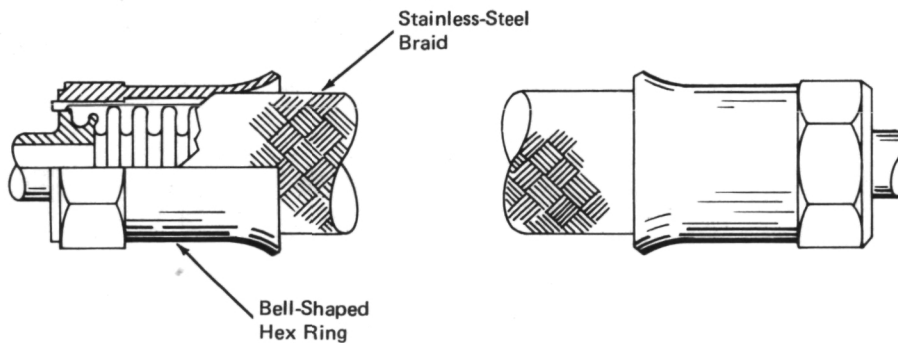

Figure 2. Bell-Shaped Sleeve

Flexible metal hose may consist of an inner core of stainless-steel convoluted tubing that is covered with stainless-steel braiding (Figure 1). The inner core and braiding are secured at the ends by welding them to an adaptor and securing them with a hex ring. Such flexible metal hoses, used with quick disconnects, often have failed due to repeated flexing during usage. Failure is most likely to occur in heat-affected areas, where the quick-disconnect adaptors are welded to the tubing.

A bell-shaped sleeve has been designed to keep the tubing from bending in the weld zone (see Figure 2). A stainless-steel hex ring used with the tubing is modified to include a bell-shaped section, which extends over the braid and the tubing to a length of approximately one

and one-half times the outer diameter of the braid. The cylindrical section has a radius that permits some flexibility but does not allow the excessive bending that causes breaking or cracking. Similar designs could be adapted to electrical connections.

Source: J. W. Humphreys and
D. L. Frazee of
McDonnell Douglas Corp.
under contract to
Marshall Space Flight Center
(MFS-22307)

Circle 3 on Reader Service Card.

TUBE CUTTER

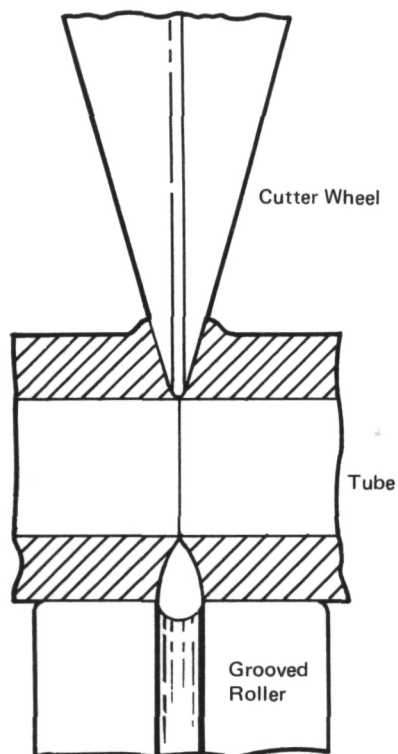

Tube Cutter

Tools which sever tubing by means of a cutter wheel often leave a small raised lip around the cut end; the lip must be removed before the tubing can be inserted into a close-fitting hole. A manual tubing cutter to cut tubing of different diameters and leave smooth edges can be made from a standard tubing cutter. The opposing smooth rollers, ordinarily used in tubing cutters, are replaced with grooved rollers shaped as indicated in the lower part of the figure.

A sharp-edged cutting wheel, as shown in the upper part of the figure, raises a lip on the periphery of the tubing, because the cutting action forces the tubing-wall material to the sides of the cut. When the cutting action begins, the small lip is cleared by the roller groove, since the groove is wider than the initial cut. As the cut becomes wider and the lip height increases, the edges of the groove in the roller bear down on the lip and prevent it from rising. Just before the tubing is severed, the width of the cut equals the width of the roller groove (as indicated in the lower part of the figure); and the smoothing action is complete.

Source: Anthony Giandomenico of
Caltech/JPL
under contract to
NASA Pasadena Office
(NPO-11524)

Circle 4 on Reader Service Card.

TUBE-TWIST PREVENTION

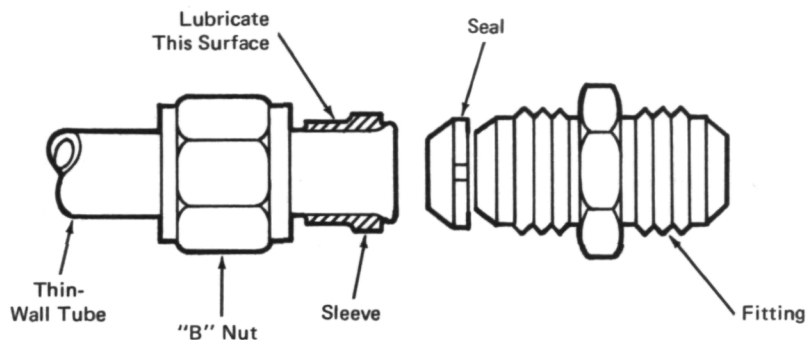

Application of Lubricant to Tube

A commercial lubricant is used to prevent twisting when thin-wall tubing is installed with flared-tube connectors. This technique requires no design changes and is fast and inexpensive. The illustration shows how the method is employed.

Generally, when the fitting is held rigid and the "B" nut is tightened, thin-wall stainless-steel tube tends to twist. A lubricant, applied in a small fillet to the shoulder of the sleeve prior to mating and torquing the tube assembly, solves the problem. The lubricated back side of the sleeve prevents the nut from binding on

the sleeve surface, which keeps the sleeve from binding on the tube.

Source: C. A. Headley of
McDonnell Douglas Corp.
under contract to
Marshall Space Flight Center
(MFS-22791)

Circle 5 on Reader Service Card.

Section 2.

Filters, Valves, Regulators, and Other Fittings

CHATTER-FREE CHECK VALVE: A CONCEPT

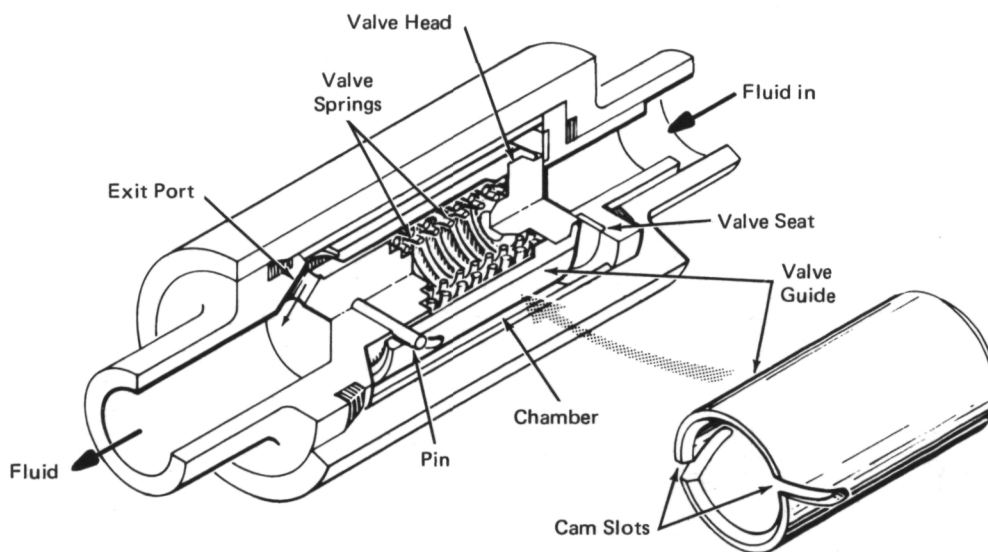

Violent chatter frequently occurs in conventional check valves having precision, hardened seats. Such chatter occurs at certain resonant conditions of fluid flow or pressure differential. It can cause erratic operation and excessive wear on the sealing surfaces, leading to premature valve failure.

A check valve has been designed to eliminate this problem. It has a valve head that moves in a spiral motion away from the seal: the motion is controlled by the travel of a pin along a spiral groove in the valve guide. Clearances between the pin and the groove permit free motion of the valve, but effectively dampen vibration and chattering.

The operating fluid passes across the valve seat and through the valve at an opening pressure determined by the effective area of the seat and the force of the valve springs. After the operating fluid passes the valve seat, it enters a chamber and exits through ports. In the check direction, the fluid is blocked at the valve-to-valve-seat interface.

The unique feature of the check valve is the action of the pin in the cam slot, causing the valve to rotate as it opens from the seat. As the valve travels in the axial direction, a force opposing such motion is produced by the resistance of the cam slot and pin, and any tendency for the valve to chatter is thus damped. The concentric arrangement of the springs, each of which has a different force coefficient, also reduces chattering by a "snubbing" action.

Source: J. E. Dunbar of
Bendix Corp.
under contract to
Johnson Space Center
(MSC-13262)

No further documentation is available.

CARTRIDGE FILTER: A CONCEPT

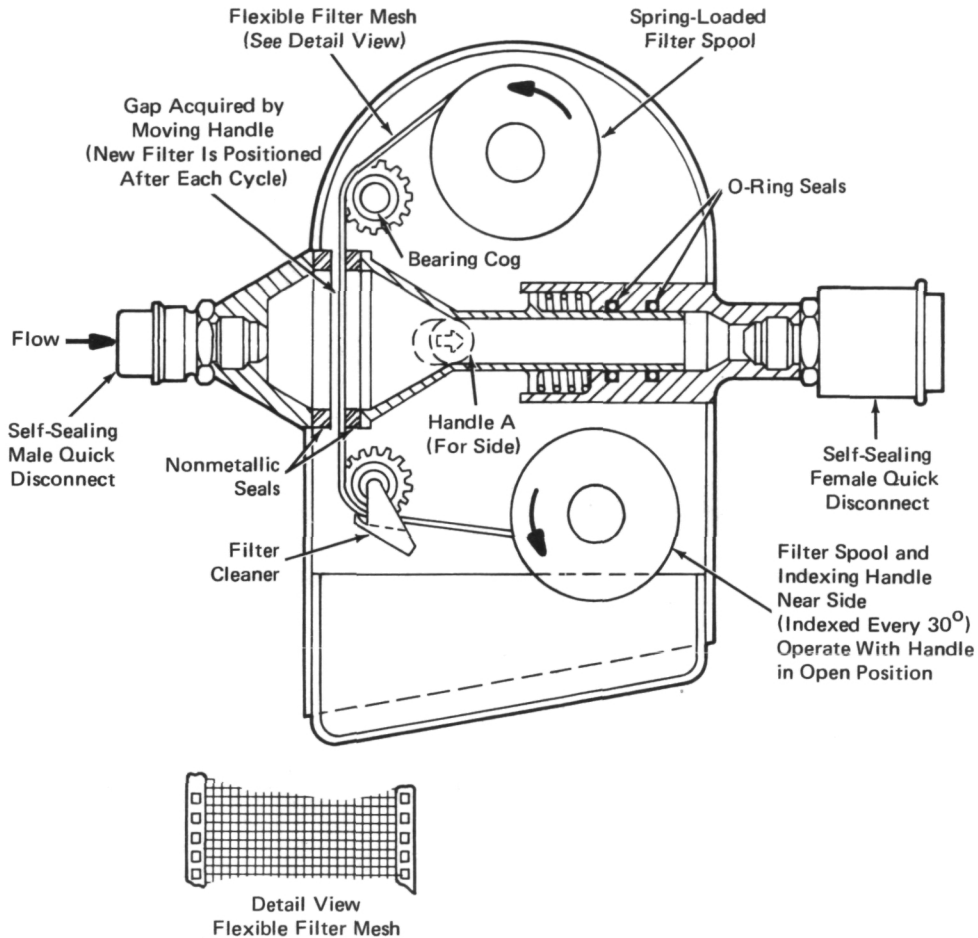

Cartridge Filter

A reel-to-reel cartridge filter, similar in construction to a super 8 movie-film cartridge, is an excellent fluid filter; but unlike conventional filters, a fresh-filter section is rolled into the flow path when back pressure builds up. Thus, continuous filtration is possible, and the accumulated solid filtrated matter can be sealed in a chamber for examination, experimentation, or disposal.

The illustration shows the details of the filter. The fluid-line seal is broken by moving a handle (A in the figure) on the cartridge. Then the filter material can be advanced from a supply reel by moving the indexing handle. After each advance, the line is resealed. Used filter material is rolled onto the secondary spool in the same way film is advanced in a camera.

This filter may be useful in laboratories where an array of samples must be processed. With slight modifications, it could be used in carburetors, air-conditioning and heating vents, clothes dryers, and as oil or air-intake filters.

Source: R. A. Kotler of
Rockwell International Corp.
under contract to
Johnson Space Center
(MSC-19297)

No further documentation is available.

PIPEFITTING WITH 360° ROTATION

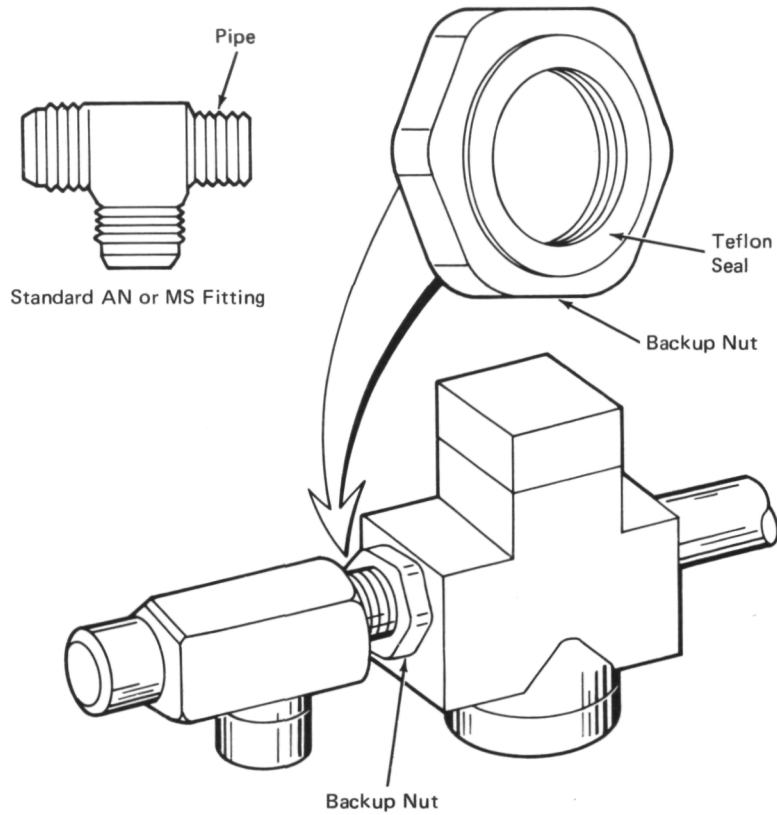

Pipefitting Allowing 360° Rotation

A pipefitting with a backup nut can be rotated 360° while maintaining an effective seal that prevents leakage. The fitting can be connected quickly in the field. The illustration shows a Teflon/steel backup nut that can be used with a variety of pipefittings, to provide the 360° rotation and thread sealing.

One male-threaded end of the fitting has a steel backup nut with a female-threaded Teflon insert. When the fitting is attached to a female-threaded opening, the backup nut can be snugged down to prevent fluid leakage. Although originally designed for 0.318-cm

(1/8-in.) through 7.62-cm (3-in.) fittings, this system can be converted to other sizes.

Source: S. L. Barajas of
Rockwell International Corp.
under contract to
Johnson Space Center
(MSC-17941)

No further documentation is available.

METAL-TO-PLASTIC TUBING CONNECTOR

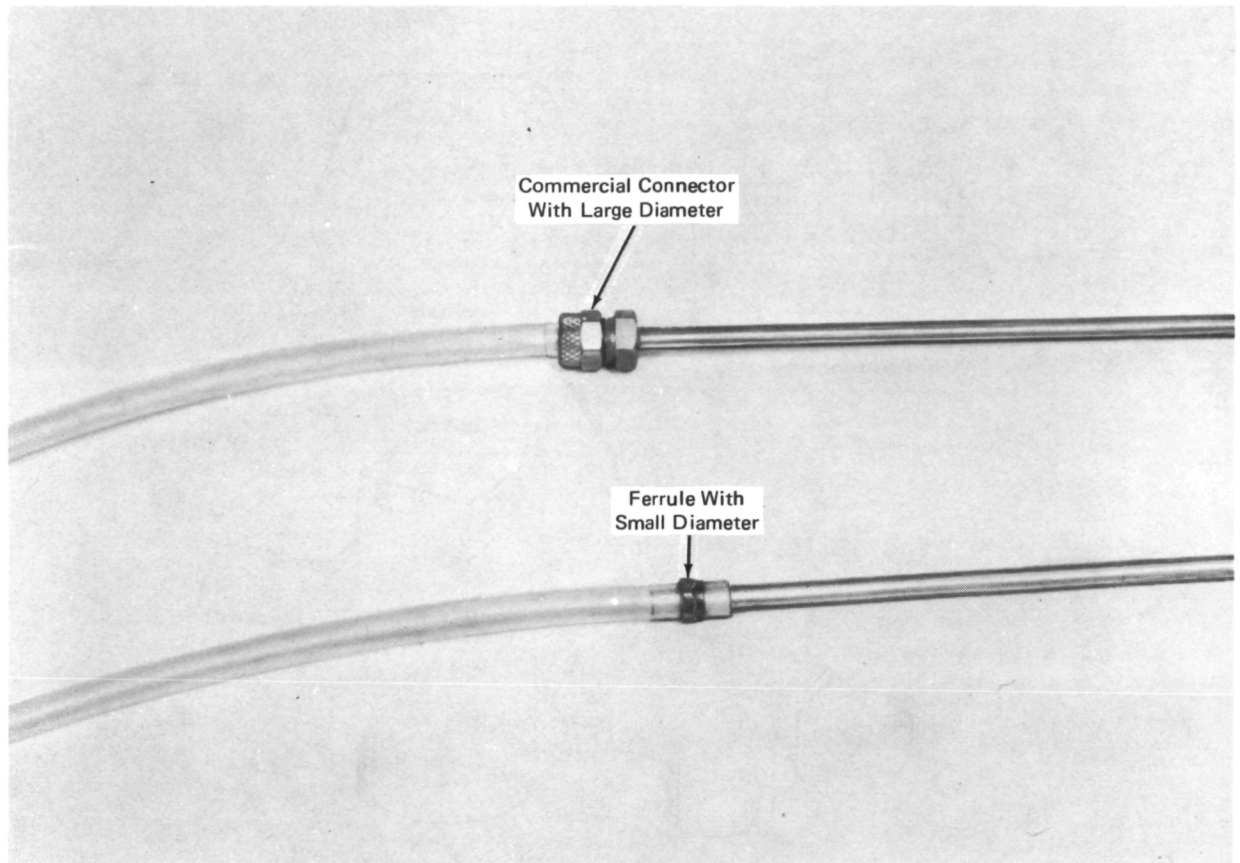

Figure 1. Comparison of Conventional and New Methods of Joining Metal and Plastic Tubing

A new plasma device, developed at Ames Research Center, required the assembly of a large number of metal-to-plastic tubing connections, to produce a tubing bundle that could be enclosed in a confined space and could withstand an internal water pressure of 4.1×10^6 N/m² (600 psi). Small commercial connectors either do not have sufficient gripping strength to prevent the plastic tubing from pulling free under pressure, or they have gripping surfaces that score or abrade the plastic tubing and cause its rupture under pressure.

Commercial connectors that do not cause the degradation of the burst strength of the plastic tubing are much too large in cross section to be used in a confined assembly (see Figure 1). In initial trials, the best of these commercial models has been modified as a three-piece assembly, by fastening the metal tubing to the male connector with silver solder. However, to prevent

pullout of the plastic tubing at high pressure, the nut is tightened sufficiently to deform the threads. As a result, the connector cannot be disassembled more than a few times.

Subsequently, it has been found that tight metal-to-plastic tubing connections can be made readily with a ferrule instead of a relatively-large threaded connector. The ferrule is selected to fit closely about the outer diameter of the plastic tubing; it is flared at its thin edge by a spherical tipped tool, such as a metal rod with a ball end. The metal tubing, with an outer diameter that fits tightly inside the plastic tubing, is scored with annular grooves (made with a tubing cutter, a diagonal wirecutter, or other special tools). When the plastic tubing is slipped over the metal tubing, its outer diameter increases to the extent that the ferrule must be forced into place over the joint. In order to set the

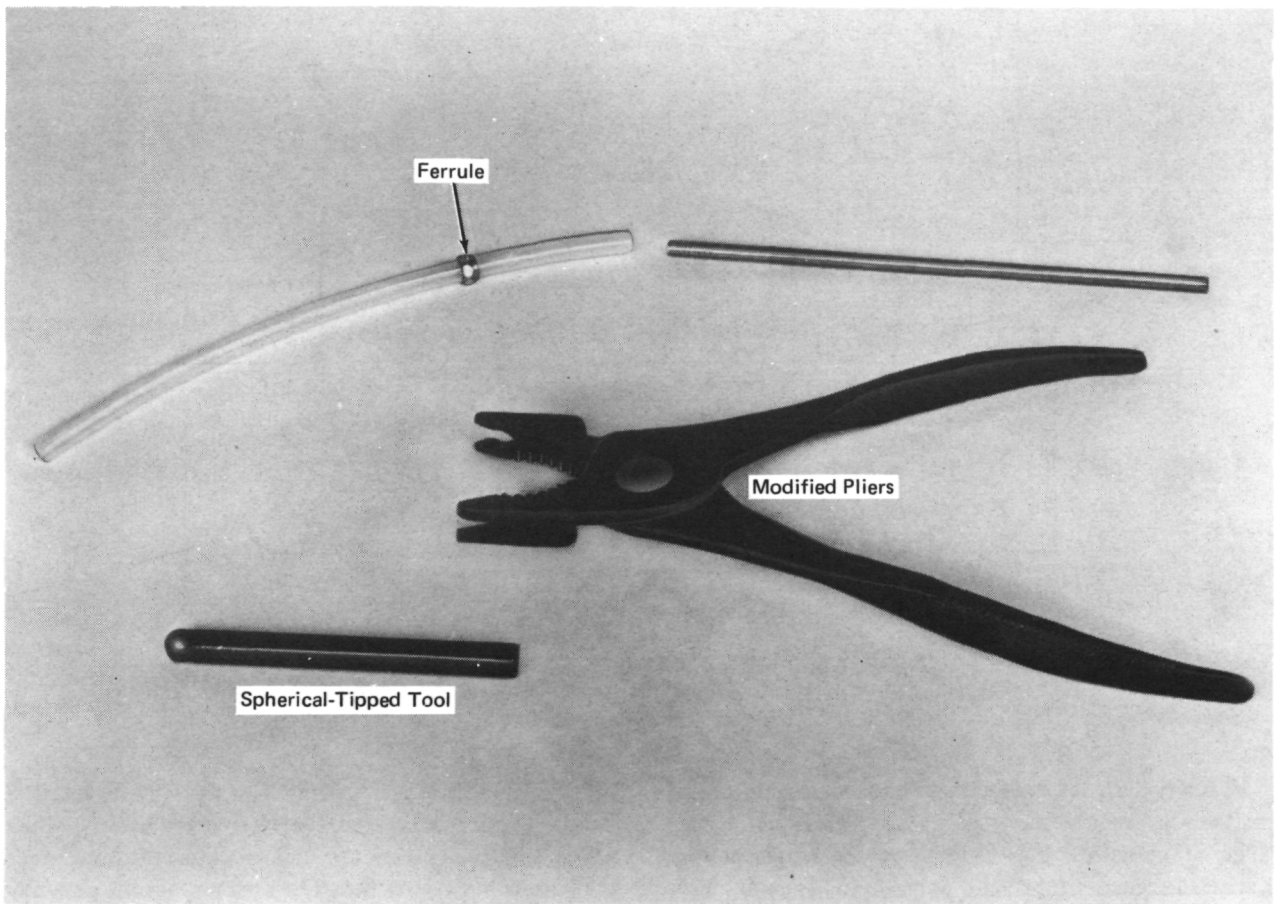

Figure 2. Tools for Connecting Tubing

ferrule, a tool has been fabricated from a pair of pliers (Figure 2); each jaw is slotted and shaped so that the pliers can be used to grip the ferrule at its larger and smaller diameters and to force it over the plastic tubing.

Tubing connections made with the ferrule have been found to withstand pressures of 6.9×10^6 to 7.6×10^6 N/m² (1000 to 1100 psi), which is very close to the rupture strength of the plastic tubing itself. For use at

low pressures, these tubing connections can be made without the annular grooves on the metal tubing.

Source: G. C. Lamica, Jr.
Ames Research Center
(ARC-10401)

No further documentation is available.

PRESSURE REGULATOR

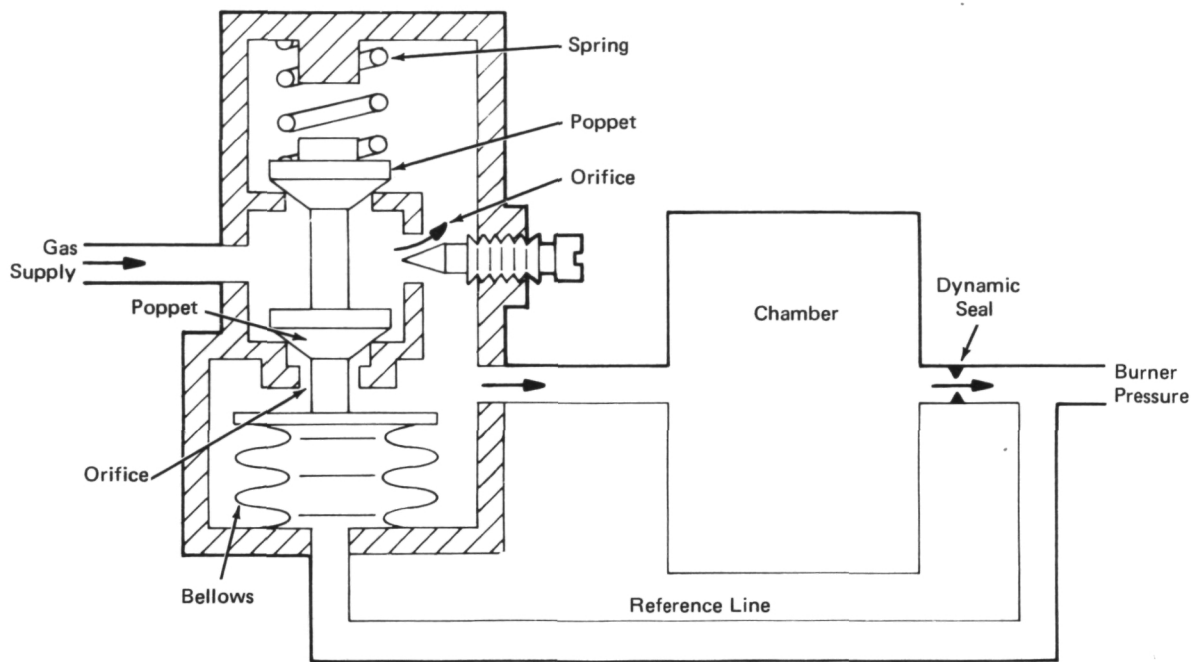

Figure 1. Pressure Regulator

A newly-designed pressure regulator maintains a small positive differential across a leakage path under a wide range of pressures. Figure 1 shows the regulator in a system designed to prevent damage to dynamic seals exposed to hot gases (1390 to 2500 K) in a ramjet engine. The regulator is connected to a chamber of given volume and pressure, which is isolated from the burner pressure by a fixed leakage path: the dynamic seal. The burner pressure is fed to the regulator through the reference line.

During operation, the valve is held closed by a light preload provided by a spring. A constant-mass flow of pressurizing gas is maintained by the orifice restrictor, which may be adjusted by turning the screw. The constant flow of pressurizing gas maintains a positive pressure differential across the leakage area when the orifice is choked. Bellows and poppets are added to improve transient response as compared to fixed restrictions. Thus, if the burner pressure increases rapidly, the difference between the burner pressure and the pressure in the chamber causes the bellows to override the preload from the spring. Then the dual poppets are

opened, and the pressurizing gas flow increases. The unique feature is the fixed orifice at the lower poppet which acts to increase the unbalance on the valve once the poppet begins to open. The dual poppet is essentially pressure balanced when closed and unbalanced when open.

Figure 2 shows the valve-position/pressure-differential relationship when the poppet orifice is choked. Once

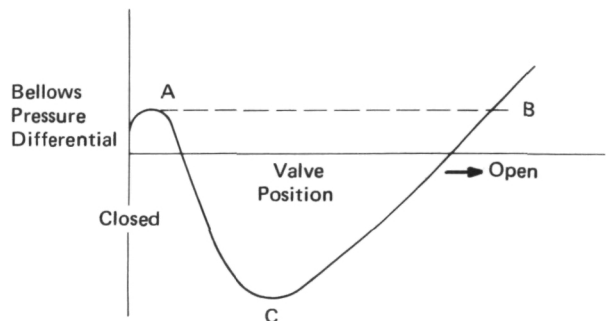

Figure 2. Valve Position Versus Pressure Differential

the differential pressure of the bellows reaches the value at point A, the valve will open to point B. With the valve open, the chamber pressure must build up above the burner pressure to point C, whereupon the valve closes automatically. The result is a valve with low-opening and high-closing force.

Source: M. W. French of General Electric Company under contract to Langley Research Center (XLA-07934)

No further documentation is available.

REPLACEABLE FILTERS AND CONES FOR FLARED-TUBING CONNECTORS

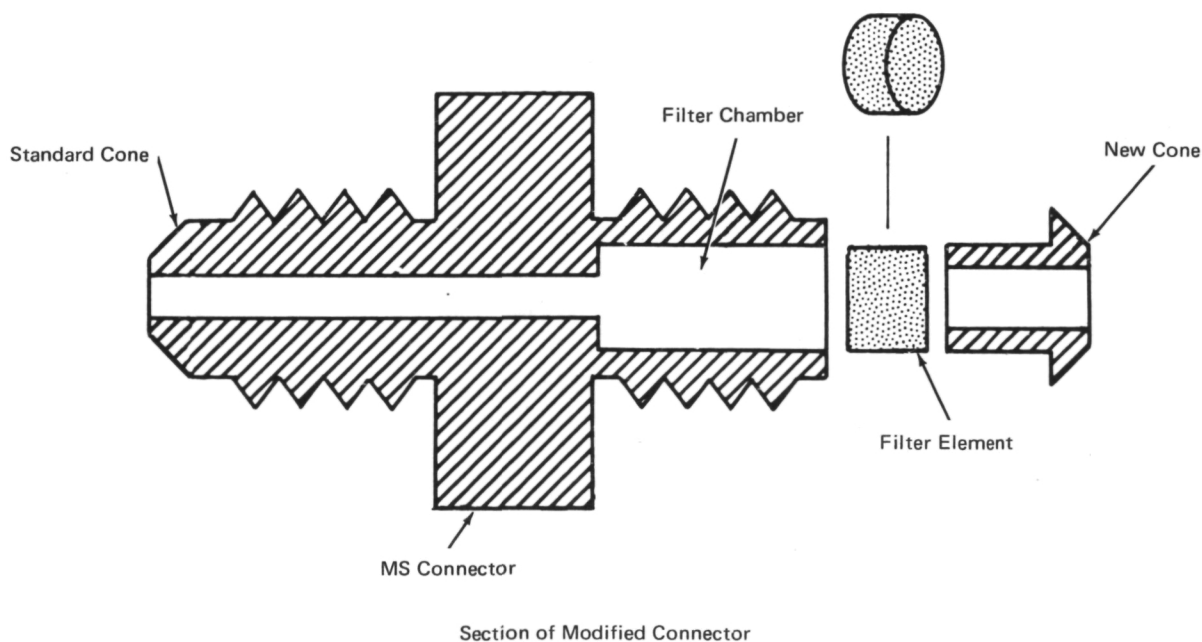

Standard connectors (types AN and MS) for flared tubing can be modified for incorporation of in-line filters and replaceable cones for seating the flares. For example, the cone is machined from one end of an MS connector (see figure) before the fitting is bored to accommodate a metallic-filament type of slip-in filter. A new cone is machined from a heat-treatable stainless steel; its shank slips into the enlarged bore, behind the filter which it holds in place. Thus, when the surface of a cone is damaged, the cone can be replaced without replacing the complete connector.

Tests have disclosed no leakage past the metal-to-metal contacts around the replaceable cone.

Source: B. T. Howland and L. E. Grant of Rockwell International Corp. under contract to Johnson Space Center (MSC-15750)

No further documentation is available.

REMOTE-CONTROLLED QUICK DISCONNECT FOR FLUID LINES

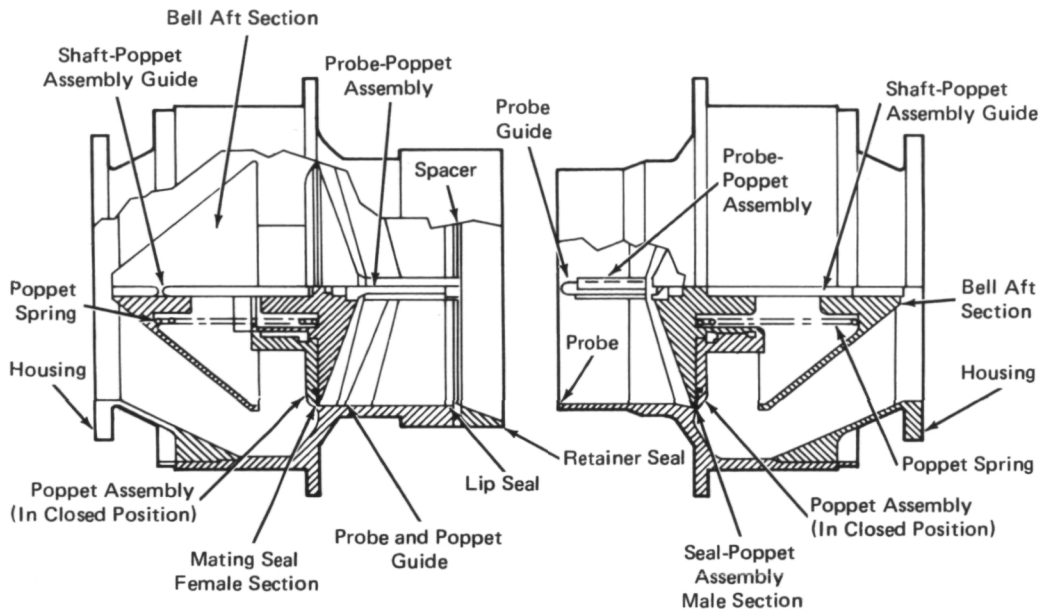

Quick-Disconnect Valve

A new disconnect assembly can be used in the transfer of hazardous fluids. Other possible uses include the transfer of gas and oil, refueling jets in flight, and the transfer of coolants in atomic power plants.

The quick-disconnect valve has a male and female half, each with a shut-off poppet (see figure). About 80 percent of the parts on the male half are interchangeable with those on the female half. This allows built-in self-alignment that assures positive engagement when the halves are joined remotely.

When the two sections are disengaged, the poppet valves are kept closed by springs. As the sections approach each other, a highly polished probe on the male half engages a pressure-sensitive lip seal on the female half. Any increase in pressure on the seal results in a corresponding increase in the force applied between the lip seal and the probe, reducing leakage at the interface between the sections. Even though the

sections are now sealed, the poppets remain closed until further axial motion forces the probe guide against a recess in the poppet assembly of the female section. Continued axial motion opens the poppets, to allow fluid flow.

When the assembly is disconnected, the process is reversed. The poppet spring closes the poppet valves before the probe disengages the lip seal. In this way, the amount of residual fluid trapped in the assembly is reduced, and leakage is kept to a minimum.

Source: R. F. Madrid of
Rockwell International Corp.
under contract to
Marshall Space Flight Center
(MFS-24425)

Circle 6 on Reader Service Card.

INDICATOR LIGHT WITH THREE-WAY LATCHING SOLENOID VALVE

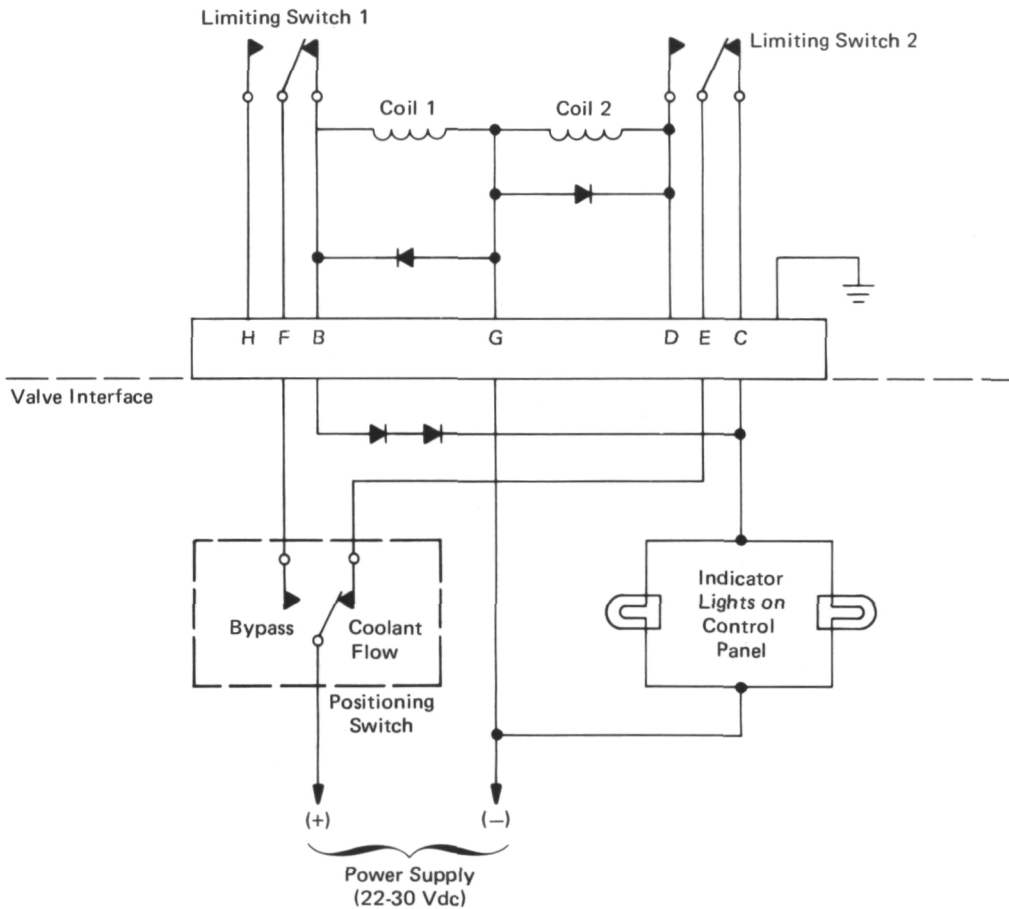

Indicator-Light System With Three-Way Solenoid Valve

A circuit employing limiting switches (see figure) eliminates the need to supply a latching solenoid valve with a pulsed dc. The single-pole double-throw limiting switches allow status lights to be operated from the same power source as valves, thus simplifying the circuitry.

In this system, the status lights are on only when coolant is being fed to the heat exchanger. When the valve is in the bypass position, the circuit terminates at pin H and the indicator lights are off. (All switches are in positions opposite those shown in the illustration.) When the positioning switch is thrown to the coolant-flow position, the limiting switches remain in positions opposite those shown. Current flows through coil II, and the valve is energized. Completion of the valve poppet translation snaps the limiting switches to the positions shown in the illustration, and the indicator lights are turned on.

To switch back to bypass, the positioning switch is thrown, poppet translation throws the limiting switches, and the indicator lights go off. Should the valve fail and not switch to bypass, the limiting switches will not be thrown. Thus, the indicator lights will be energized via pin B and will remain on, indicating the true condition.

Source: R. J. Dannenmueller and
J. F. Schuessler of
McDonnell Douglas Corp.
under contract to
Marshall Space Flight Center
(MFS-22491)

Circle 7 on Reader Service Card.

TRANSPIRATION SEAL

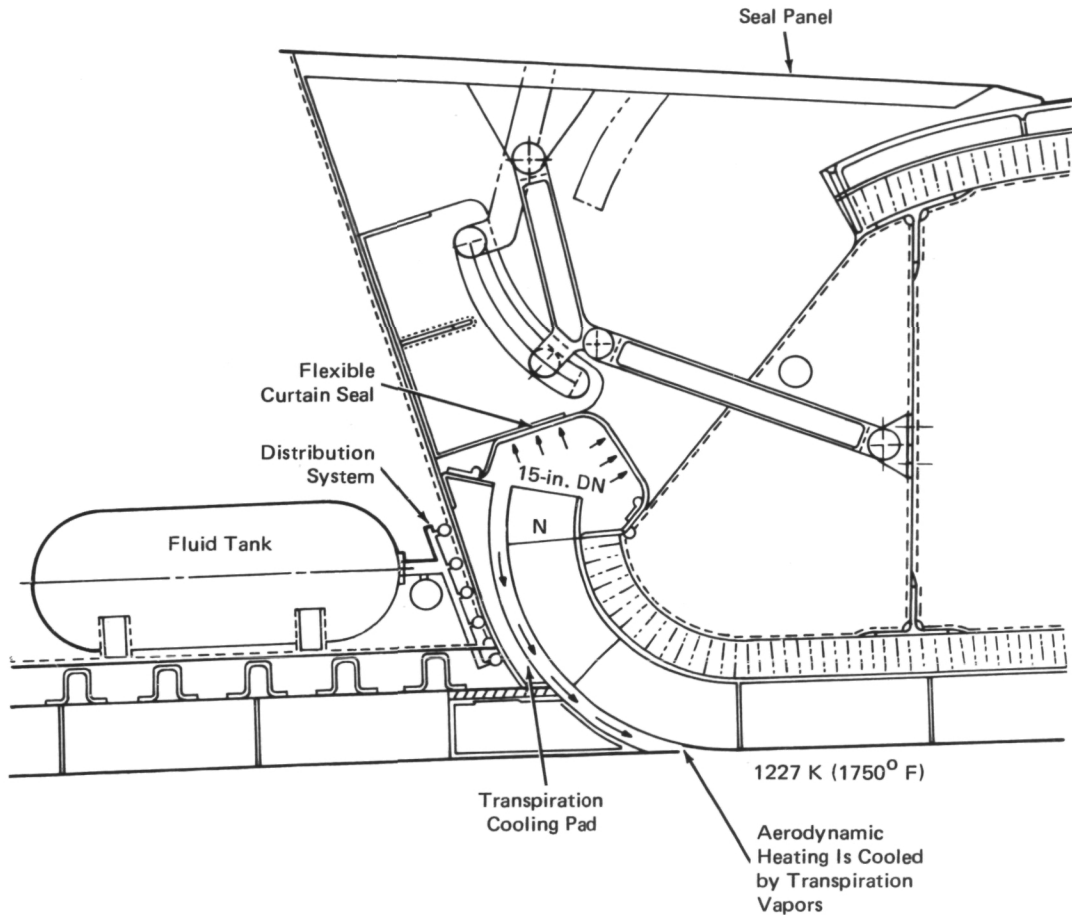

Transpiration Seal as Used on an Elevon

A new transpiration seal can cool as well as seal a cavity. The high-temperature seal was developed for a space shuttle elevon, but may be useful in refineries, nuclear-reactor systems, and other high-temperature equipment.

The seal is shown in the figure. With increasing temperature, water is vaporized from the transpiration cooling pad and flows outward, preventing hot gases from entering the chamber. The vaporization of the water and the vapor itself cool the cavity. An inner curtain seal prevents the vapors from contaminating the machinery.

Since the chamber is cooled, refractory metals need not be used for the machinery. There are no rubbing

parts to cause friction and chafing, and smaller thermal-expansion gaps may be used. The absence of a mechanical seal prevents jamming, and the vapor seal solves problems arising from the permanent-set characteristics of metal and cloth mechanical seals.

Source: R. S. McElhiney of
McDonnell Douglas Corp.
under contract to
Johnson Space Center
(MSC-14585)

No further documentation is available.

**MODIFICATIONS TO A VACUUM-ASSISTED FILTERING DEVICE
TO MINIMIZE CONTAMINATION**

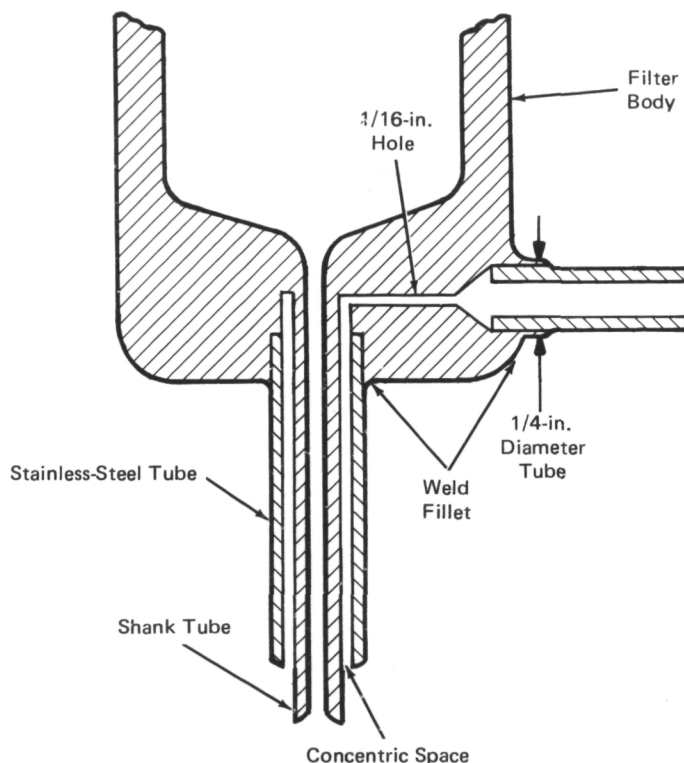

Vacuum-Assisted Filter Unit

A commercially available high purity filter unit has been modified to save time and expense in laboratory operations and to improve the purity of the liquids processed.

The preparation of particle-free liquids, such as solvents for washing silicon microcircuits and other delicate electronic components invariably presents difficulties. Filtration is recognized to be the simplest technique available. Depending on the viscosity of the liquid being filtered and the pore size of the filter, however, filtration can be a time-consuming process unless the process is "assisted" by the application of pressure or a vacuum. Pressure filtering is sometimes useful for the filtration of viscous liquids, but vacuum filtering is the most convenient method of purifying low viscous liquids.

A glass Erlenmeyer site tube flask is the customary apparatus for vacuum filtration. Unfortunately, such fragile flasks are expensive, difficult to keep clean, and

as they are only used as transfer vessels the logical solution is a filtering device equipped with a vacuum connection which will perform the function of the Erlenmeyer flask.

A commercial filter unit (supplied by the Millipore Corp., Bedford, Mass.) has been modified to embody the vacuum requirement described. A cross section of the filter body and details of the modification is illustrated in the figure.

Experience has shown that any but the most viscous liquids can be processed by the modified unit equipped with the appropriate filter medium. Moreover, its use eliminates much of the tediousness of cleaning glassware.

Source: Saverio Gaudiano
Johnson Space Center
(MSC-13733)

Circle 8 on Reader Service Card.

MODIFIED COUPLING PROVIDES LOW-TEMPERATURE, VACUUM-TIGHT SEAL

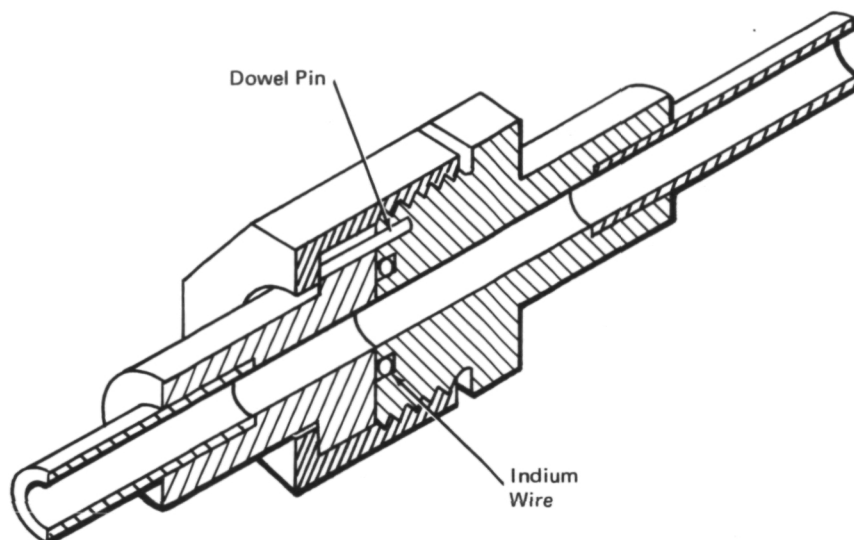

Low-Temperature Vacuum-Tight Seal

A standard face-seal coupling has been modified to provide an easily assembled and disassembled reusable seal for joints in metal tubing systems. It has been used successfully to seal tubing systems containing either gaseous helium or a vacuum, at room or liquid nitrogen temperatures. Standard flange fittings are bulky, and metal or plastic gasket seals must be replaced each time they are reassembled. The modified face-seal coupling is less bulky and can be reused many times without replacing the seal element and without incurring leaks.

The standard brass face-seal noncryogenic coupling has been modified to replace a rubber O-ring seal with a piece of indium wire, which makes it suitable for cryogenic service (see figure). The O-ring groove in one side of the coupling body is remachined to a width of

0.152 cm (0.060 in.) and a depth of 0.102 cm (0.040 in.). Indium wire 0.152 cm in diameter is cut to length; the ends are butted together and placed in the groove. Matching holes are drilled in both halves of the coupling to receive a dowel pin to keep the coupling from rotating as it is tightened. At liquid nitrogen temperatures, indium wire seals better than other easily-available, soft-metal wire, such as copper and lead.

Source: Wayne R. Smith
Lewis Research Center
(LEW-11909)

No further documentation is available.

BALANCE-TYPE, ADJUSTABLE, CRYOGENIC BACK-PRESSURE REGULATOR

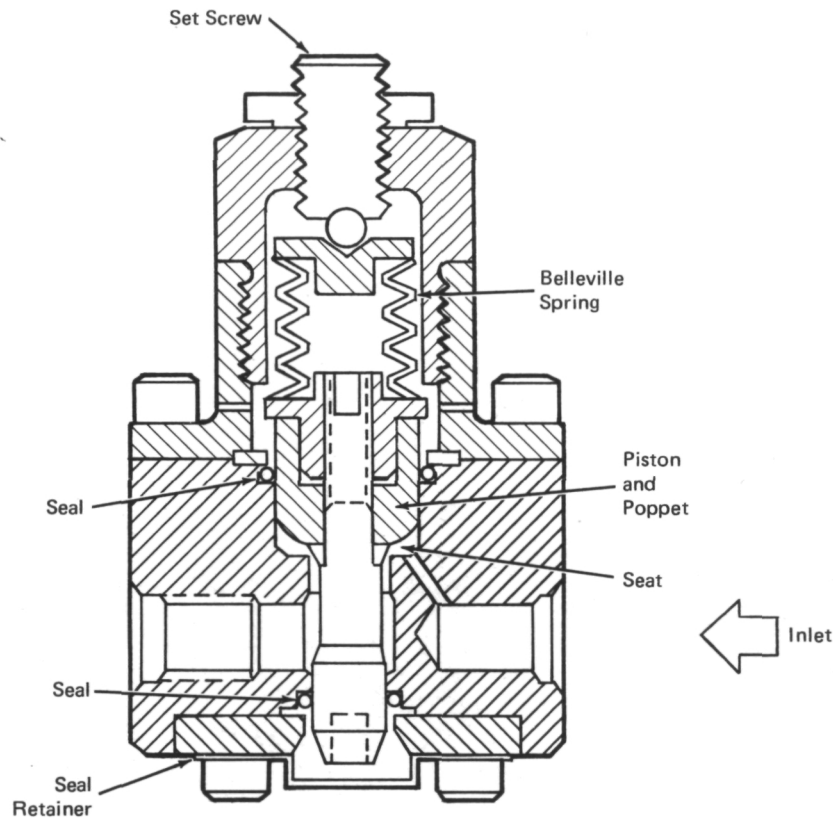

Back-Pressure Regulator With Balanced Outlet

A balance-type, adjustable back-pressure regulator controls pressures as high as $31 \times 10^6 \text{ N/m}^2$ (45 psig), over a temperature range of 16 to 533 K (-430° to $+500^\circ$ F). As shown in the figure, the back-pressure regulator consists of a spring-actuated piston, which controls the flow through an orifice, to maintain a desired back pressure. A balanced outlet scheme causes the fluid pressure forces, which tend to displace the poppet, to maintain any equilibrium.

Pressure is adjustable manually, with a setscrew that changes the initial spring displacement. A Belleville spring applies pressure to the piston. Among the advantages of the system are: (a) an inert construction

material, (b) compatibility with liquid oxygen and liquid hydrogen, (c) manual adjustability, (d) ease of operation and accessibility, and (e) positive adjustability throughout the full working range.

Source: S. L. Barajas of
Rockwell International Corp.
under contract to
Johnson Space Center
(MSC-19124)

No further documentation is available.

DEVICE FOR PRETESTING POPPET VALVES

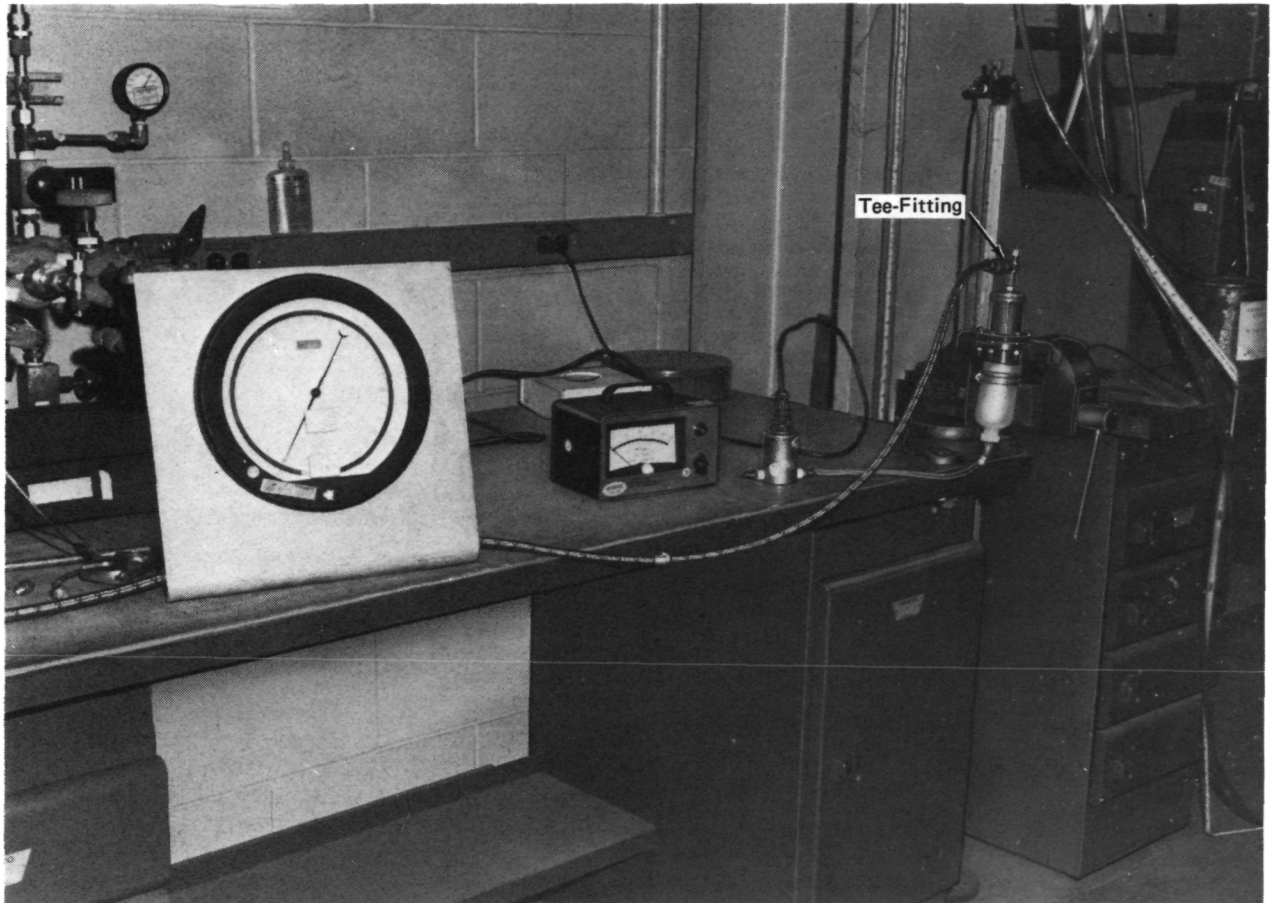

Pretesting a Poppet Valve in Vertical Position

A new apparatus has been developed to test a poppet valve that is used to trigger a larger valve. Many large valves incorporate such poppets, and it is necessary to assemble the valves to test the poppets. This is especially expensive when specifications are strict, as it is frequently necessary to assemble and reassemble a system several times until a poppet is found to meet all requirements.

With the new test device, the poppet may be pretested, avoiding costly assembly and reassembly. A plate, drilled and tapped to take a Tee fitting, is welded to the unflanged end of a poppet-valve housing. The poppet valve to be tested is attached to the housing by inserting a sealing gasket and bolting the mating flanges together. At the other end of the poppet valve, a plastic housing is clamped to the poppet-valve housing, and a plastic tube is attached to the plastic housing.

A controlled air supply is fed into one of the Tee fittings. The figure shows the valve being tested in a vertical position. The other Tee-fitting is used when the valve is tested in a horizontal position. The plastic tubing is connected to a flowmeter, and air is passed through the poppet valve at a given pressure. Any leakage past the valve will be noted as a change in the flow rate.

Source: A. R. Carter and W. J. Reaves of
The Boeing Company
under contract to
Kennedy Space Center
(KSC-10840)

No further documentation is available.

Section 3. Fluid Assemblies and Equipment

RECTANGULAR CONCENTRIC-TUBE INJECTOR

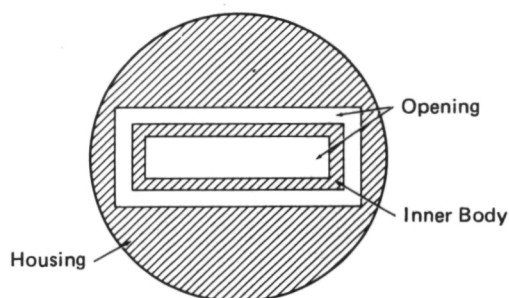

Rectangular Concentric-Tube Injector

Injectors are used to atomize liquids in a liquid/gas interchanger. They are normally circular in shape. However, a rectangular-tube injector (see figure) has been found to have a higher efficiency, and it produces smaller drops than conventional circular-tube injectors.

The rectangular-tube element also has promising mixing characteristics. The atomization performance is directly proportional to the aspect ratio of the injector tube, but for mixing there may be an optimum aspect ratio. The mass-to-mixture ratio distribution shows that maldistribution is characterized by a high liquid concentration in the outer zones. This suggests that the injected-gas momentum is very effectively transferred through shear along the large gas/liquid periphery. Thus, the liquid phase is highly aspirated and is thrown outside the flow field. It is predicted that the liquid

distribution may be made uniform by selecting an optimum ratio, somewhere between 6:1 and 1:1.

The control of liquid distribution by varying the aspect ratio also suggests that rectangular-tube elements may be tailor designed for specific uses. The flow pattern could be designed to enhance injector-chamber compatibility and to control heat flux in the chamber.

Source: R. M. McHale of
Rocketdyne Corp.
under contract to
Johnson Space Center
(MSC-15980)

No further documentation is available.

SUPPORT OF FLUID-ASSEMBLY COMPONENTS

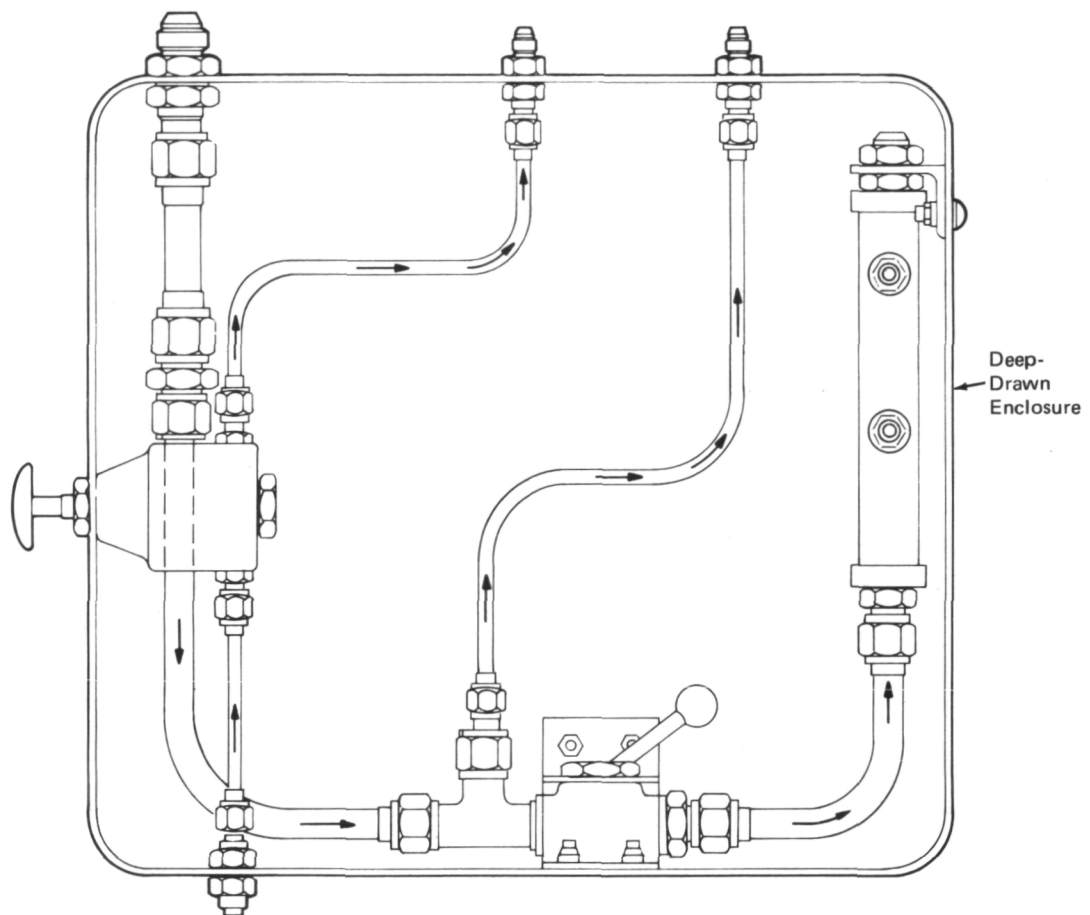

Container Used to Support a Typical Fluid Assembly

Commercially-available, deep-drawn metal containers can be used as the supporting structure for portable fluid systems. The container, a thin-walled, one-piece metal can, will support many different types of tubing and fittings (see figure). The walls and the bottom surface can be used for markings, diagrams, or other information.

The use of a drawn can, rather than panel and frame supports, reduces manufacturing time and cost, and design changes are easy to make. The box can be either a supporting structure or a protective enclosure, and the rounded corners and the absence of structural parts give a better appearance to customer-deliverable items.

A deep-drawn container can be an effective replacement for presently used techniques in fluid systems found in medical test equipment, laboratory setups, hydraulic machinery, and food-processing equipment.

Source: E. E. Evans and H. F. Cass of
Rockwell International Corp.
under contract to
Johnson Space Center
(MSC-17182)

Circle 9 on Reader Service Card.

**AUTOMATIC VACUUM-CYCLING APPARATUS FOR CLEANING
BOURDON-TUBE GAUGES**

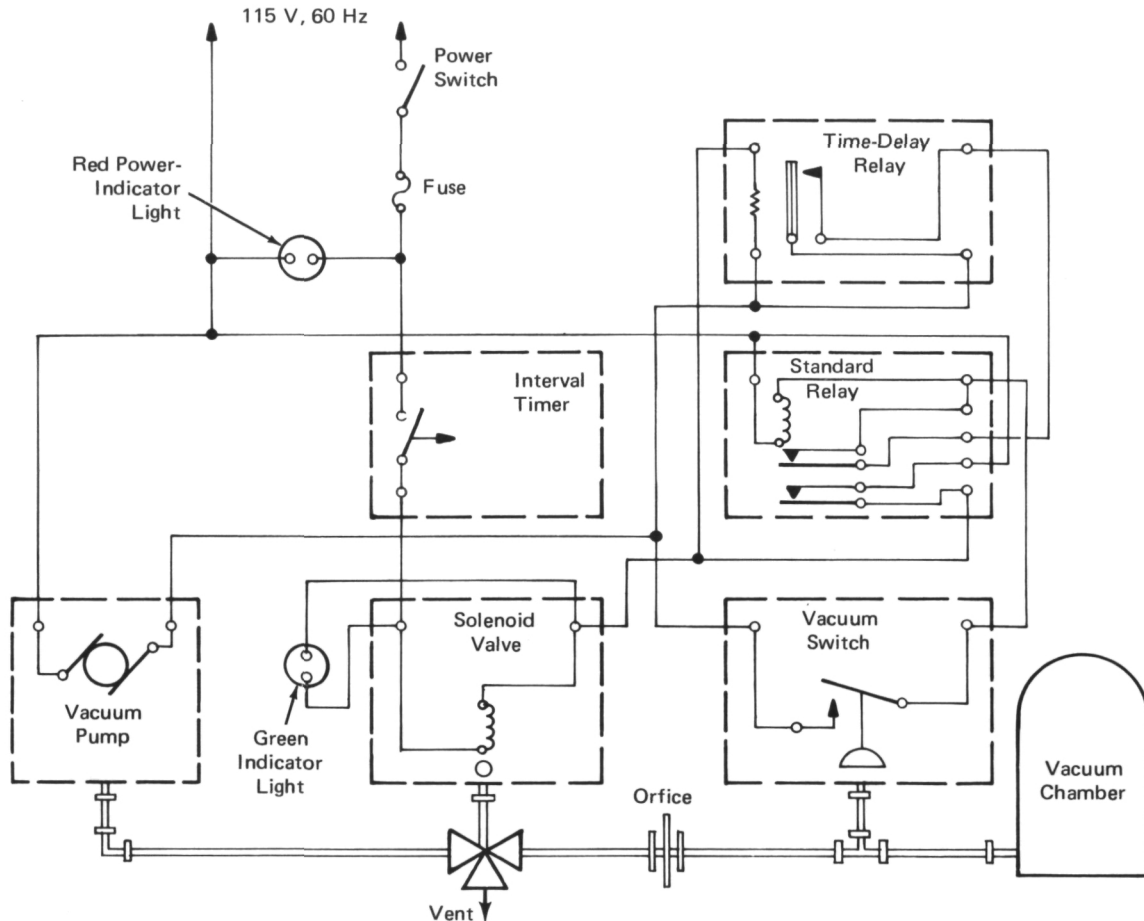

Apparatus for Cleaning Bourdon-Tube Gauges

Bourdon-tube pressure gauges used for compressed gases usually are cleaned by placing them in a vacuum chamber, which is pressurized and evacuated repeatedly. This time-consuming manual operation has been automated and made more efficient. The diagram shows the components of the automated system.

The total desired time for cleaning is preset on the interval timer, and the vacuum switch is adjusted to the desired vacuum. The power switch is closed, causing the red power indicator to light up and turning on the vacuum pump by way of the interval timer. When the pressure is reduced to the appropriate value, the vacuum switch closes and the standard relay closes the solenoid valve on the line to the vacuum pump. The green indicator light turns on to identify the venting cycle. The vacuum chamber then is vented to the atmosphere through the orifice.

The pressure in the vacuum chamber is elevated gradually to atmospheric pressure (within 5 to 7 seconds), and the vacuum switch opens. This energizes the solenoid valve and applies current to the heating element of the time-delay relay. Within 10 seconds, the contacts of this time-delay relay open and it returns to its normally open condition. When the voltage is removed from the solenoid valve, it returns to its normally open position; and the cycle starts again.

Source: S. J. Yasho of
Bendix Corp.
under contract to
Kennedy Space Center
(KSC-10331)

Circle 10 on Reader Service Card.

DYNAMICS OF A FLEXIBLE BULKHEAD AND CONTAINED FLUID

A theoretical study has determined the effects of sloshing within a tank. The tank and fluid are modeled as assemblages of liquid and shell elements. A finite-element formulation is obtained to study the vibrational characteristics of liquid in a flexible container of general shape. To retain sparsity in the assembled system-mass and stiffness matrices, a compressible liquid-element formulation is used. Consequently, the liquid finite-element formulation is compatible with structural finite elements.

The study shows that the sloshing models and frequencies are not affected appreciably by the flexi-

bility of the tank. The vibrational characteristics of a container, however, are influenced by the presence of sloshing liquid. This study may have application to underwater oil-storage tanks and cargo vessel tanks.

Source: G. C. Feng and C. E. Jones of
Lockheed Aircraft Co., Inc.
under contract to
Marshall Space Flight Center
(MFS-22747)

Circle 11 on Reader Service Card.

AIR DIFFUSER ASSEMBLY

A diffuser has been designed to disperse a stream of blowing air. It can be installed on the outlet side of an axial-flow fan or with any air duct that is downstream from a fan or other gas-moving device. When set at a narrow diffusion pattern, this diffuser does not deflect the moving stream, as is the case with most other diffusers. Furthermore, it is adjustable to any desired dispersion pattern.

The mechanism consists of an adjustment knob, a drive-shaft assembly, a primary and secondary housing, and a set of bell cranks, which convert translatory motion into rotary motion. A set of diffuser blades and

blade shafts deflect the moving air. An outlet screen can also be incorporated, to protect the mechanism from damage.

Source: G. C. Jensen of
McDonnell Douglas Corp.
under contract to
Marshall Space Flight Center
(MFS-21733)

Circle 12 on Reader Service Card.

LIGHTWEIGHT TRANSFER UNIT FOR POTABLE WATER

A lightweight, portable unit can deliver precisely measured quantities of water. The system includes a GN₂ leak test feature, and can be used to purge, dry, and sterilize water systems. Despite its excellent accuracy, the system is relatively simple and may be constructed from standard gauges, valves, and pipes.

The water-delivery system has an accuracy of ± 1 percent, at a flow rate of 3.8×10^{-3} to 5.7×10^{-3} m³/min. (1 to 1.5 gal./min). Leaks from 0 to 2000 standard cm³/hr can be detected with an accuracy of $\pm 1/2$

percent, and the filters will remove all particles larger than 0.2 micrometers.

Source: P. A. Lanxner and R. A. Brown of
Rockwell International Corp.
under contract to
Johnson Space Center
(MSC-17195)

Circle 13 on Reader Service Card.

Patent Information

The following innovation(s) described in this Compilation, have been patented or are being considered for patent action as indicated below:

Break-Resistant Flexible Hose (Page 4) MFS-22307

Inquiries concerning rights for the commercial use of this invention should be addressed to:

Patent Counsel
Marshall Space Flight Center
Code CC01
Marshall Space Flight Center, Alabama 35812



POSTMASTER: If Undeliverable (Section 158
Postal Manual) Do Not Return

"The aeronautical and space activities of the United States shall be conducted so as to contribute . . . to the expansion of human knowledge of phenomena in the atmosphere and space. The Administration shall provide for the widest practicable and appropriate dissemination of information concerning its activities and the results thereof."

— NATIONAL AERONAUTICS AND SPACE ACT OF 1958

NASA TECHNOLOGY UTILIZATION PUBLICATIONS

These describe science or technology derived from NASA's activities that may be of particular interest in commercial and other non-aerospace applications. Publications include:

TECH BRIEFS: Single-page descriptions of individual innovations, devices, methods, or concepts.

TECHNOLOGY SURVEYS: Selected surveys of NASA contributions to entire areas of technology.

OTHER TU PUBLICATIONS: These include handbooks, reports, conference proceedings, special studies, and selected bibliographies.

Technology Utilization publications are part of NASA's formal series of scientific and technical publications. Others include Technical Reports, Technical Notes, Technical Memorandums, Contractor Reports, Technical Translations, and Special Publications.

Details on their availability may be obtained from:

Details on the availability of these publications may be obtained from:

National Aeronautics and
Space Administration
Code KT
Washington, D.C. 20546

National Aeronautics and
Space Administration
Code KS
Washington, D.C. 20546