

General Disclaimer

One or more of the Following Statements may affect this Document

- This document has been reproduced from the best copy furnished by the organizational source. It is being released in the interest of making available as much information as possible.
- This document may contain data, which exceeds the sheet parameters. It was furnished in this condition by the organizational source and is the best copy available.
- This document may contain tone-on-tone or color graphs, charts and/or pictures, which have been reproduced in black and white.
- This document is paginated as submitted by the original source.
- Portions of this document are not fully legible due to the historical nature of some of the material. However, it is the best reproduction available from the original submission.

(NASA-CR-137802) ANIMAL EXPOSURE DURING
BURN TESTS Final Report (Douglas Aircraft
Co., Inc.) 64 p HC \$4.50 CSCL 06C

N76-20800

Unclas

G3/51 23446

ANIMAL EXPOSURE DURING BURN TESTS

FINAL REPORT

by James G. Gaume, M.D.

January 1976

Distribution of this report is provided in the interest of information exchange. Responsibility for the contents resides in the author or organization that prepared it.

Prepared under Contract No. NAS2-8668 by
DOUGLAS AIRCRAFT COMPANY
Long Beach, California

for

AMES RESEARCH CENTER

NATIONAL AERONAUTICS AND SPACE ADMINISTRATION



**ORIGINAL PAGE IS
OF POOR QUALITY**

1. Report No. NASA CR-137802	2. Government Accession No.	3. Recipient's Catalog No.	
4. Title and Subtitle ANIMAL EXPOSURE DURING BURN TESTS FINAL REPORT		5. Report Date January 1976	
		6. Performing Organization Code	
7. Author(s) James G. Gaume, M.D.		8. Performing Organization Report No. MDC J7133	
		10. Work Unit No.	
9. Performing Organization Name and Address Douglas Aircraft Company McDonnell Douglas Corporation 3855 Lakewood Blvd. Long Beach, California 90846		11. Contract or Grant No. NAS 2-8668	
		13. Type of Report and Period Covered Contractor Report	
12. Sponsoring Agency Name and Address National Aeronautics and Space Administration Washington, D.C. 20546		14. Sponsoring Agency Code	
		15. Supplementary Notes Project Manager, Demetrius A. Kourtides NASA Ames Research Center Mountain View, California	
16. Abstract An animal exposure test system (AETS) has been designed and fabricated for the purpose of collecting physiological and environmental (temperature) data from animal subjects exposed to combustion gases in large scale fire tests. The AETS consists of an open wire mesh, two-compartment cage, one containing an exercise wheel for small rodents, and the other containing one rat instrumented externally for electrocardiogram (ECG) and respiration. Cage temperature is measured by a thermistor located in the upper portion of the rat compartment. Temperature range recorded is 0°C to 100°C. The ECG and respiration sensors are located in a belt placed around the torso of the subject, electrode wires forming an umbilical to a connector in the top of the compartment. A cable extends from the connector to the power supply and signal conditioning electronics. These are connected to a dual-beam oscilloscope for real-time monitoring and a magnetic tape recorder having three or more channels. After the burn test, the data on the tape is reproduced in the laboratory on an 8-channel Beckman Type SII Dynagraph for analysis. Endpoints observed are bradycardia, cardiac arrhythmias, changes in respiratory pattern, respiratory arrest and cardiac arrest. The ECG record also appears to be a good method of monitoring of animal activity as indicated by an increase in EMG (electromyograph) noise superimposed on the record during increased activity of the torso musculature. Examples of the recordings are presented and discussed as to their significance regarding toxicity of fire gases and specific events occurring during the test. The AETS has been shown to be a useful test tool in screening materials for the relative toxicity of their outgassing products during pyrolysis and combustion. Recommendations for future effort include (1) improvement of the system effectiveness, (2) utilization of the system to enlarge the data bank of physiological responses to fire gases, (3) investigation in the laboratory of the responses to selected fire gases and extinguishing agents, singly and in combination.			
17. Key Words (Suggested by Author(s)) Fire Tests, Animal Exposure System, Toxicity, Toxicology, Physiological Responses		18. Distribution Statement Unclassified - Unlimited	
19. Security Classif. (of this report) Unclassified	20. Security Classif. (of this page) Unclassified	21. No. of Pages	22. Price*

* For sale by the National Technical Information Service, Springfield, Virginia 22151

TABLE OF CONTENTS

INTRODUCTION AND BACKGROUND	1
OBJECTIVES	3
APPROACH	5
DESIGN CRITERIA	7
EXPOSURE CAGE DESIGN	9
INSTRUMENTATION	15
RESULTS	21
DISCUSSION	43
CONCLUSIONS AND RECOMMENDATIONS	45
REFERENCES	47
APPENDIX	49

LIST OF FIGURES

FIGURE

1	EXPOSURE CAGE ON ARTICULATED SUPPORT STAND. . .	10
2	MARK II CAGE.	11
3	DISSASSEMBLED SUPPORT STAND	13
4	ASSEMBLED SUPPORT STAND	14
5	ELECTRODE BELT STRUCTURE.	16
6	LATERAL AND TOP VIEW OF ECG ELECTRODE	16
7	LAB. RECORDINGS OF ECG & RESPIRATION ILLUSTRATING EMG	19
8	TEMPERATURE PROFILE, CFS TEST	22
9 - 16	REPRODUCED BOEING TEST PHYSIOLOGICAL DATA . . .	25 - 32
17	BOEING TEST DATA MAJOR GASES IN ENCLOSURE . . .	34
18	BOEING TEST DATA CONCENTRATION OF HCN	35
19	BOEING TEST DATA CONCENTRATION OF HCl	36
20	BOEING TEST DATA CONCENTRATION OF HF	37
21	BOEING TEST DATA AIR TEMPERATURE IN ENCLOSURE .	38
22	FUEL SOURCE FOR BOEING TEST	39
23	PLACEMENT OF AETS FOR BOEING TEST	40
24	UCB RICHMOND TEST DATA AETS TEMPERATURE PROFILE	41

LIST OF TABLES

1	ADVANTAGES OF OPEN & CLOSED CAGE SYSTEMS . . .	7
2	CFS PHYSIOLOGICAL DATA SUMMARY	23
3	BOEING TEST PHYSIOLOGICAL DATA SUMMARY.	24

INTRODUCTION AND BACKGROUND

Recent emphasis on the development of fire-safe materials, safety procedures and techniques has brought to the attention of all concerned that there is no standard test to determine the relative toxicities and rating of candidate materials for use in the interiors of commercial passenger aircraft. Such a test for materials evaluation has been developed by the U.S. National Bureau of Standards and by which the burning characteristics of materials can be rated, but which does not indicate relative toxicities of materials under the same conditions. Fire statistics show that 60-70% of fatalities among all fire victims, including those resulting from aircraft fires, are killed by "smoke" (1), which is defined by fire-fighters and investigators as the particulate matter and the fire gases which evolve during combustion. Therefore, it appears that a standard test to determine the relative toxicities of materials (2) is sorely needed for the preliminary selection of optimum materials, or to establish new design criteria for the development of improved polymeric materials for the fire safety, whatever the application.

First, a short discussion of definitions may be in order. The term "toxicity" has been used frequently during discussions on fire gases. Many times it has been used interchangeably with quantitative units of measurement of fire gases. Quantitative units of measurements, per se, have nothing to do with denoting toxicity. The definition of toxicity (3) is "the quality of being poisonous and is expressed by a fraction indicating the ratio between the smallest amount that will cause an animal's death and the weight of that animal". This requires definition of the term "poison" (3) which, according to Dorland is "any substance which, when ingested, inhaled or absorbed, or when applied to, injected into, or developed within the body, in relatively small amounts, by its chemical action may cause damage to structure or disturbance of function". From these definitions, then, one can conclude that the agent in question must be related to a living biological specimen, and that a quantitative unit of measurement without this relationship cannot alone indicate the degree of toxicity.

This leads to the evaluation of standard toxicological terms used to describe toxicity. These are LD₅₀ and LC₅₀ which indicate the dose or concentration required to kill 50% of the experimental animals. This criterion of LC₅₀ is untenable when it is applied to human survival and escape from the fire situation wherever it might be. Some years ago, a new term, the Time of Useful Function (TUF) was suggested by Gaume (4) as a more appropriate term to indicate the time available for a person to escape the fire environment before incapacitation by fire gases, after which it would not be possible to do so without help. The ability to escape is dependent on the magnitude of the consolidated biokinetic forces for environmental deterrance over a given period of time (5). The TUF may be considered as an analogue of the universally-accepted TUC (Time of Useful Consciousness) applicable to flight crews upon aircraft cabin decompression.

By definition, then, the toxicities of various fire gases can be determined, for human purposes, only by collecting data on exposed animals or humans, the latter being generally unacceptable subjects for these kinds of hazardous experiments. Therefore, animal subjects are the only alternative for building a data bank of biological effects from which scale factors can be developed via mathematical modelling and further experimentation. For purposes of the data bank related to fire safety, escape and survival, the collection of physiological data should be oriented toward the TUF rather than to the LC50 concept. It would seem that the definition of poison fits the TUF concept more appropriately than that of toxicity.

The TUF will be variable under different circumstances and will depend on a variety of factors. Among these are the materials that are burning, their ignition temperatures, heat flux, fire temperatures, oxygen supply, ventilation and air currents, retardant treatment, the gases evolved, their generation rates, and others. These variables, combined with the many physiological variables present in the escapee's body, and the many types of gases evolving (asphyxiant, irritant, anesthetic, narcotic, systemic poisons), present a very complex problem which is in urgent need of simplification. A standard test based on the TUF concept may well provide a simple, inexpensive means of determining the relative toxicities of materials, enhancing their selection, and therefore, fire safety. The TUF method provides a rapid, simple and perhaps the only means of integrating all these complex variables without the requirement to investigate each one individually, at high cost in time and money. Once materials have been rated by such a test, the synergistic or antagonistic effects of each combination or concentrations of gases, and other single variables, can be investigated more leisurely on the basis of pre-determined priorities. Our understanding of synergism and antagonism may undergo some change as a result of investigation of controlled gas mixtures (6).

The method of investigation reported in this document is among the several which can be standardized and inexpensively utilized in establishing the toxic threat of various materials, conventional or advanced, for whatever application --aircraft, homes, office buildings, or hotels.

OBJECTIVES

The objectives of this program have been:

1. To develop an animal exposure test system (AETS) for utilizing small animals as subjects (S_5) in large-scale burn tests. The AETS should be capable of being standardized so that any investigator, following the specifications set forth, can build and utilize the system and achieve results which can be accurately compared with those of another investigator using the same system.
2. To utilize the AETS in large-scale burn tests to collect physiological (cardiac and respiratory), environmental (temperature), and physical activity data to enable the relative toxic threat assessment of burning materials, in single or multiple specimens. The system should also be applicable to various laboratory-scale experiments without or with minor modifications.

APPROACH

Douglas studied the NASA plans, protocols, schematics for the full-scale burn tests of an aircraft lavatory to be conducted in 1975 at the test facilities of the Boeing Company, Seattle, Washington (7) and of a simulated lavatory at the University of California at Berkeley (Richmond) (8). The design requirements and criteria for a standardizable animal exposure test system (AETS) were developed from this study. The AETS had to be compatible with the primary test facility and plan. The AETS was to be a separate system but integratable with the primary test facility. Design considerations included such parameters as type of material for the chamber, its size, number of subjects to be accommodated, placement of sensors and sample ports within or near the chamber, methods of monitoring subject's activity and gas concentrations as well as length of sampling lines, and methods of sampling.

The gas analysis methods used were to be the same as those used in the primary test facility and were to be performed by the same laboratories and by the same technicians. This procedure was necessary for accuracy in gas analysis, particularly when a sampling method is used. On-line continuous gas analysis for O₂ and CO would have required a separate set of analyzers, if a closed cage were used. Thus, unnecessary duplication of instrumentation and manpower was avoided.

A conceptual design for the AETS was developed based on these considerations, followed by final design and fabrication of the AETS. A test plan, integrated with and compatible with the primary test plan, was developed.

The AETS, including subjects and instrumentation, was transported and installed in the Boeing Company facility and in the UCB-Richmond Fire Test Facility at Richmond, California. Douglas participated in three large-scale burn tests of aircraft lavatories. Douglas operated the AETS, collected and analyzed the data resulting from the exposure of animals to evolving fire gases, and presented conclusions as to the relative toxicity of the combustion products as a function of the materials involved in the fire bases on the gas analysis data collected by the Boeing Company and NASA ARC.

The parameters analyzed included:

- ° Air temperature within the AETS cage.
- ° Activity of freely-moving subjects before and during exposure to evolved gases.
- ° Electrocardiographic and respiratory patterns before and during the test exposure on one instrumented subject.
- ° Correlation of the physiological and cage temperature data with the gas analysis data.

PRECEDING PAGE BLANK NOT FILMED

DESIGN CRITERIA

The AETS concept selected for development required a trade-off study between an open and a closed cage system. The advantages of each system are detailed in Table 1.

Table 1. Advantages of Open and Closed Cage Systems

OPEN	CLOSED
1. More realistic exposure milieu	1. Subject shielded from direct flame and heat
2. Photography is easier --fewer highlights	2. Subject has a separate milieu (not realistic)
3. Fabrication is more simple --materials easier to work, less time involved	
4. Lower cost	
5. Can be shielded from direct flame and heat	
6. Gas sampling is easier --fewer, shorter lines --eliminate duplicate analyzers --few samples to analyze	
7. Can be a disposable system	
8. Fewer design requirements, less complex	

Based on this trade-off study, an open cage system was chosen for development.

PRECEDING PAGE BLANK NOT FILMED

Additional design criteria set forth for the AETS included:

1. Low cost
2. Simple design
3. Easily reproducible
4. High reliability
5. Standardizable
6. Convenient transportability
7. Adaptable to any large-scale test facility
8. Must be able to correlate physiological data with gas analysis and temperature data.
9. Results readily and quickly analyzable

The design of the AETS cage was based on the TUF concept of determining the toxic threat of a given fire environment. The statement of work called for the monitoring of freely-moving subjects (S_5) and one S instrumented for electrocardiogram and respiration. This necessitated either a minimum of two cages or a single two-compartment cage. The latter was selected and a study made of the compartment's required dimensions based on number and sizes of the S_5 in each compartment and the equipment provisions required.

EXPOSURE CAGE DESIGN

A conceptual design of an open cage was developed after consideration of several potential configurations. It consisted of a redwood base and doors with a wire mesh superstructure. The 0.635 cm (1/4 inch) mesh was of a size to contain the smallest animal used. The cage wire and base would be blackened to improve contrast and to avoid all possible light reflections which might degrade the cinematography. Smoke interference could be quite severe and the image of a white subject against black should improve this method of monitoring activity. A photo of this configuration is shown in Figure 1. The cage dimensions are 60.96 cm (25 in.) long, 30.48 cm (12 in.) wide, and 30.48 cm (12 in.) high, with a round top.

The ceiling of the rat compartment contains a quick disconnect plug into which the rat electrode belt, positioned on the torso of the rat, is plugged. The cable from this plug stretched 2.44 metres (8 feet) to another quick disconnect plug incorporated into a wall plate for attachment to the outside wall of the test enclosure. Another cable extends to the electronic signal conditioner module which in turn is connected to the oscilloscope and tape recorder.

Exposure Cage, Mark II Version

Following the June 11, 1975 test at Boeing, a different concept of the exposure cage was developed. The new concept was stimulated by the unwieldy size and weight of the shipping crate necessary to transport the Mark I AETS.

The Mark II concept consisted of two separate cages of approximately the same dimensions of a 22.86-25.40 cm (9-10 inches) cube made of four separate sides, and separate floor and lid. The dimensions are sufficient to accommodate (1) the exercise wheel for mice for monitoring activity by photo or video coverage, and (2) the instrumented rat in the other. 0.635 cm (quarter-inch) hardware cloth is used for all pieces. The sides' corners are joined by spirally-wound wire designed for 1.27 cm (half-inch) turns penetrating alternate 0.635 cm spaces in the edge of each pair of sides. Spirals are started at the top of the sides and screwed toward the bottom. The floor section is an inverted dish 1.27 cm to 1.9 cm (1/2 inch to 3/4 inch) deep and is inserted upward into the cage from the bottom after all sides are joined. The floor is locked in place by shorter spiral wires starting at the bottom. These can also be designed to serve as cage feet if it is desired to raise the cage further. The raised floor allows for the removal of excreta from the cage during occupancy. The lid is also dish-shaped with 1.9-2.54 cm (3/4-1 inch) depth, and 0.635 cm to 1.27 cm (1/4 to 1/2 inch) larger than the size of the assembled cube. The corners of the floor and lid can be soldered or wired together or not, as desired. The lid can be held in place after placing the S_5 in the cage by a number of different mechanism. The one used initially was a spring-loaded double-hooked clamp extending from the lid to the lower cage, or to the cage support platform. Figure 2 shows one cage disassembled and one cage assembled. The lid is slightly larger so that the other sections of the collapsed cage can be packed inside it to reduce space required for packing and transport.

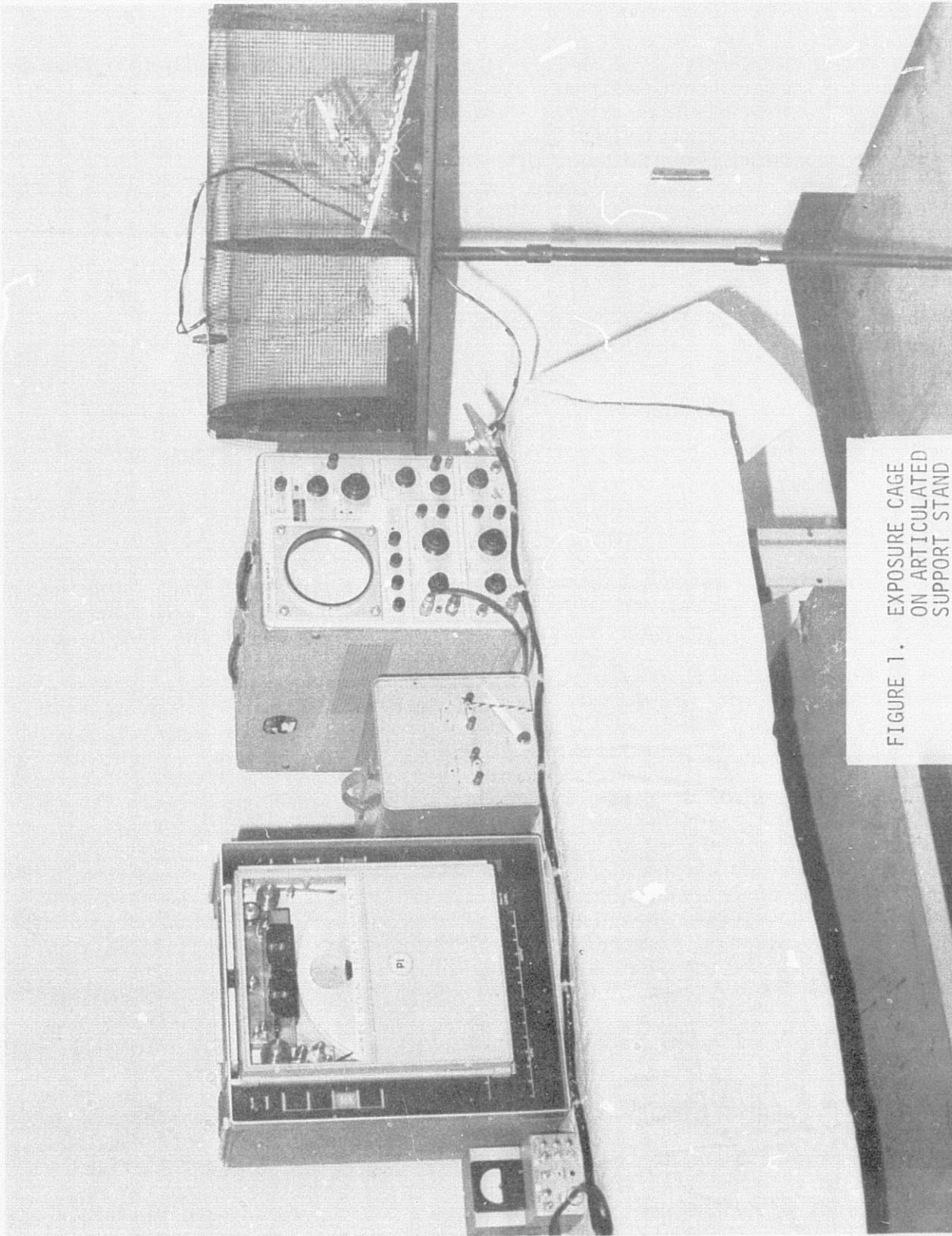

FIGURE 1. EXPOSURE CAGE ON ARTICULATED SUPPORT STAND

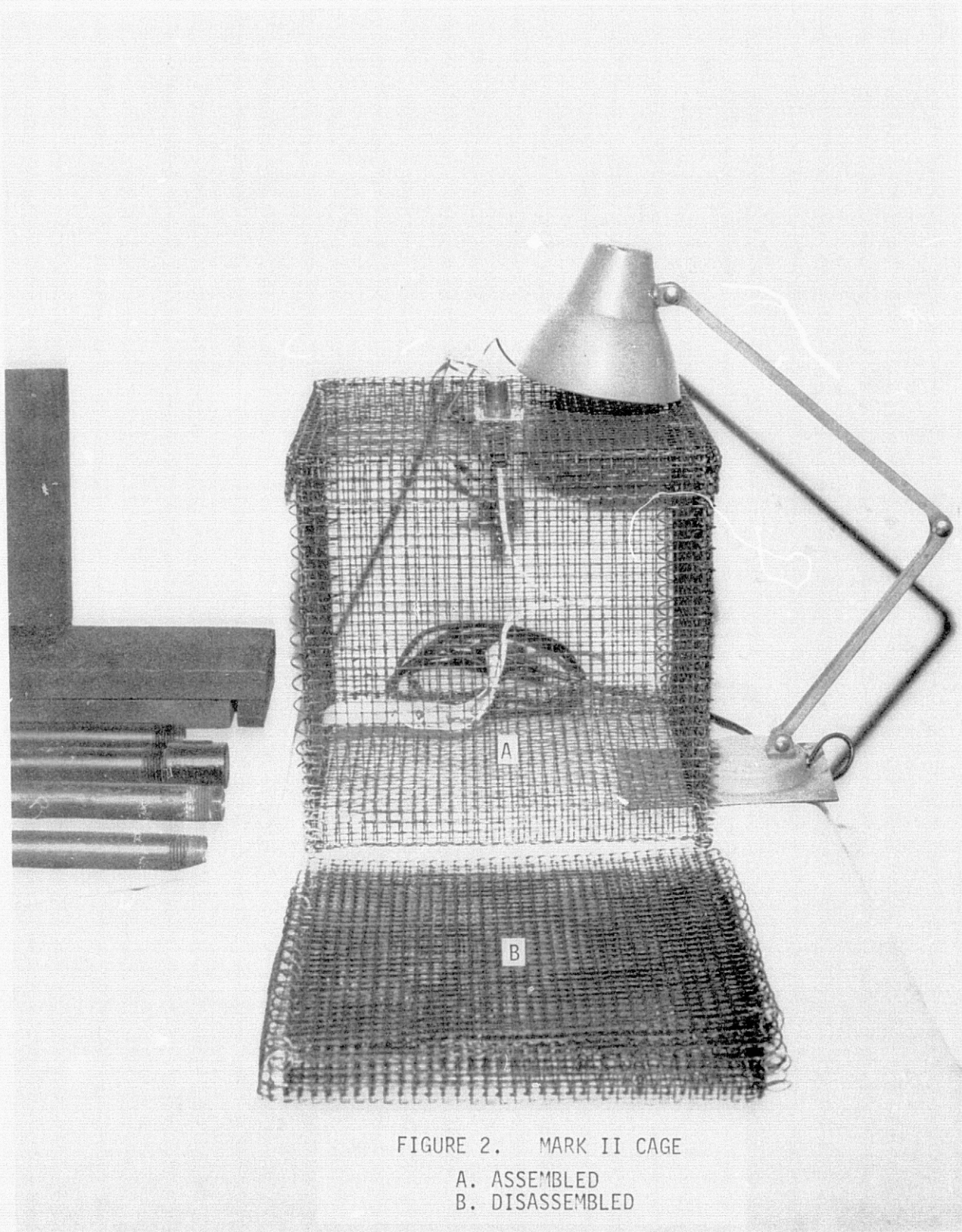

FIGURE 2. MARK II CAGE

- A. ASSEMBLED
- B. DISASSEMBLED

Support Stand Design

The base of the support stand is fabricated of two pieces of 1.9 cm x 10.16 cm x 60.96 cm (3/4 inch x 4 inch x 24 inch) plywood held in the form of an X by two bolts and wing nuts. One piece has feet on the ends. The upright consists of variable length sections of 1.27 cm (1/2 inch) iron pipe joined by straight couplings to each other, and to the base and to the bottom of the cage platform by 4-holed pipe flanges. This provides for an infinitely variable cage height. The cage platform is of 1.9 cm x 10.16 cm x 55.88 cm (3/4 inch x 4 inch x 22 inch) plywood, one end of which is inserted into a retainer loop on the cage bottom and is locked in place by a pin through the opposite end of the cage and the platform. This end of the cage is positioned toward the monitor's window and is so designed for quick removal from the enclosure by opening the window, removing the pin, sliding the cage retainer loop off the platform and removing the cage through the window. The quick-disconnect wall plug from the cage to the inside enclosure wall is first disconnected. The entire removal operation requires approximately 10 seconds. The support stand is shown disassembled in Figure 3 and assembled in Figure 4.

Base Redesign

The support stand base was re-designed to reduce the spread from 60.96 cm (24 inches) to 50.8 cm (20 inches) for use with the Mark II cages because of reduced cage weight and size. Also, the new base is collapsible without having to disassemble it. Setting-up and tearing-down time of the AETS is thus reduced, and packing for transport is facilitated. The entire support stand, two cages, lamp, and exercise wheel can be packed and transported in a carry-on size case.

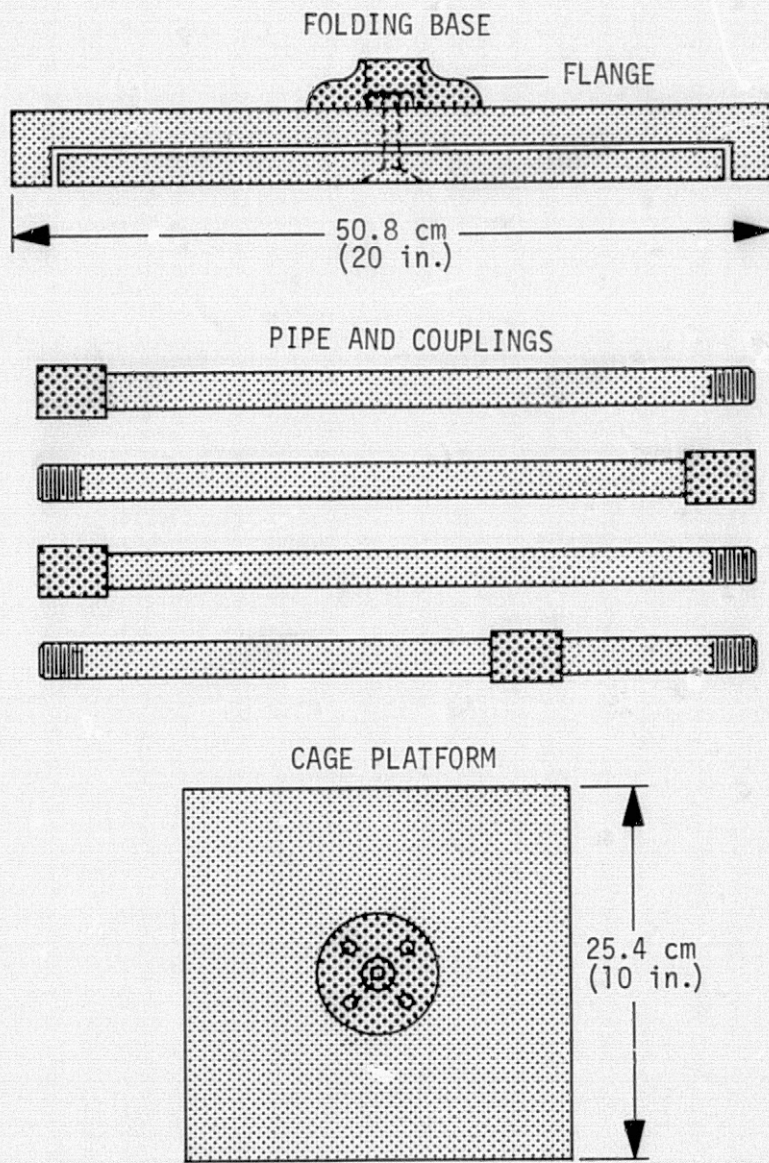

FIGURE 3. DISSASSEMBLED SUPPORT STAND

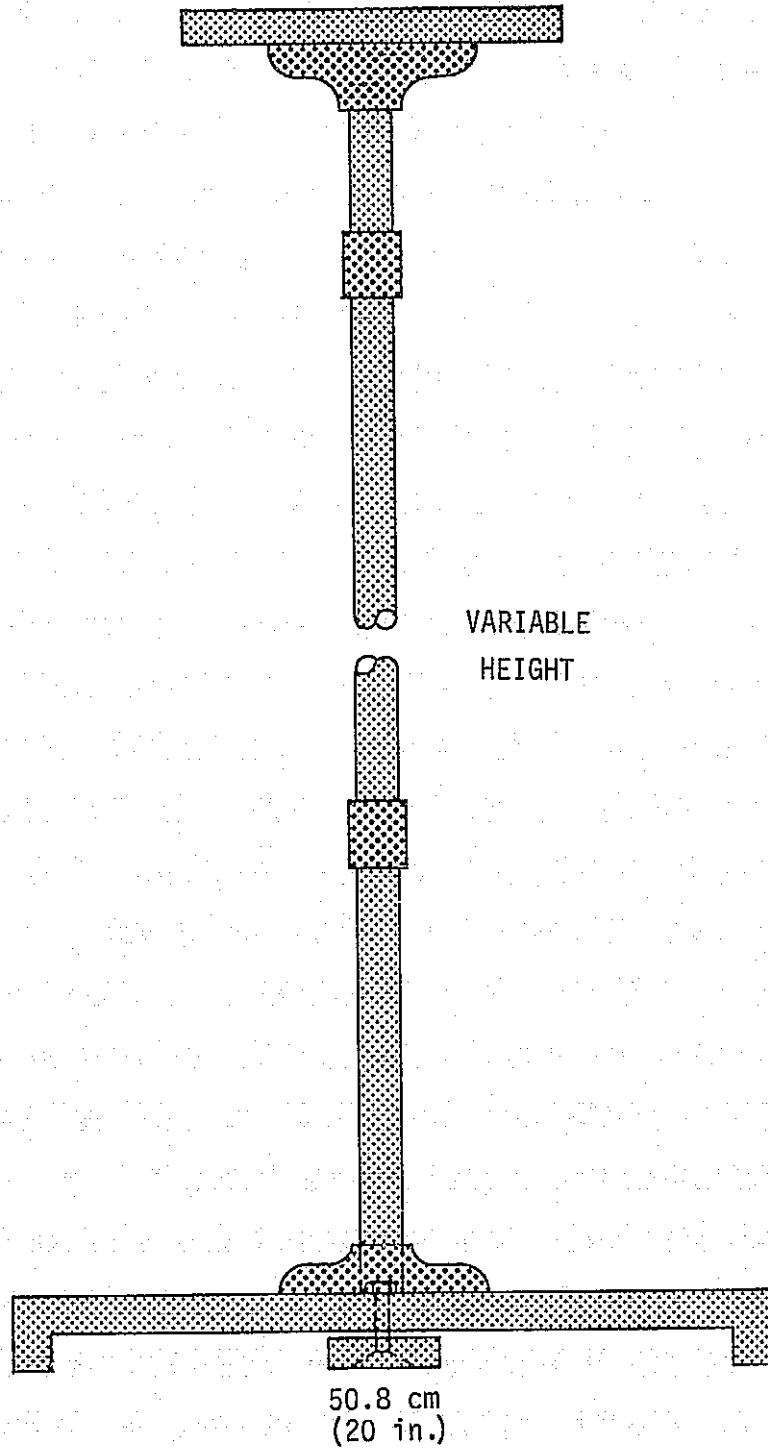

FIGURE 4. ASSEMBLED SUPPORT STAND

INSTRUMENTATION

Physiological

Background

The rat subject was instrumented for electrocardiogram and respiration. These kinds of data have been recorded on human subjects during the pursuance of the Company's IRAD programs. It was decided that the techniques utilized in these programs for data acquisition and analysis would be adapted to the rat subject. A literature search for external instrumentation techniques for ECG and respiration revealed no viable method already in use by other investigators. Most researchers used implanted sensors on rat subjects. Various conceptual electrode vests, jackets, and belts were fabricated and applied to see if the S would tolerate them and not divest himself of the device. It was found that a simple 1.9 cm (3/4 inch)-wide belt around the chest, containing two elastic sections, using velcro to fasten the ends, appeared to be retained by the subject with less apparent discomfort than some of the previous methods of fixation to the S.

Sensors

A piezo-electric respiratory transducer previously used for human subjects was incorporated into the center of the belt between the two elastic sections of equal length and two velcro sections distal to these. Figure 5 illustrates the structure of the electrode belt (E.B.).

Next, the design of the surface ECG electrodes was considered. Standard Beckman disposal Telectrodes were modified, tested, and found to be unsatisfactory. Loops of metal wire, through which the S's front legs were put were then fabricated. These were fastened to the outer ends of elastic sections. This technique showed promise but was temporarily rejected. The final electrode design, however, consisted of a rounded thumb tack drilled with four holes into which were soldered short sections of paper clips. These were filed a length suitable for penetration of the fur of the S, particularly after clipping. Figure 6 is a lateral view schematic of the ECG electrode.

The entire electrode was then gold-plated. To apply the electrode to the belt, the pin of the tack was pushed through the elastic section, one on either side of the respiration sensor after determining the proper placement in the belt after optimum stretching and fastening on the subject. Wires (teflon-coated) were then soldered to the pin, joined with the other wires from the other electrode, the respiration transducer, and the two ground wires from ECG and respiration, to form the umbilical cable to the plug at the ceiling of the cage. The length was sized to permit the subject free access to any portion of his compartment.

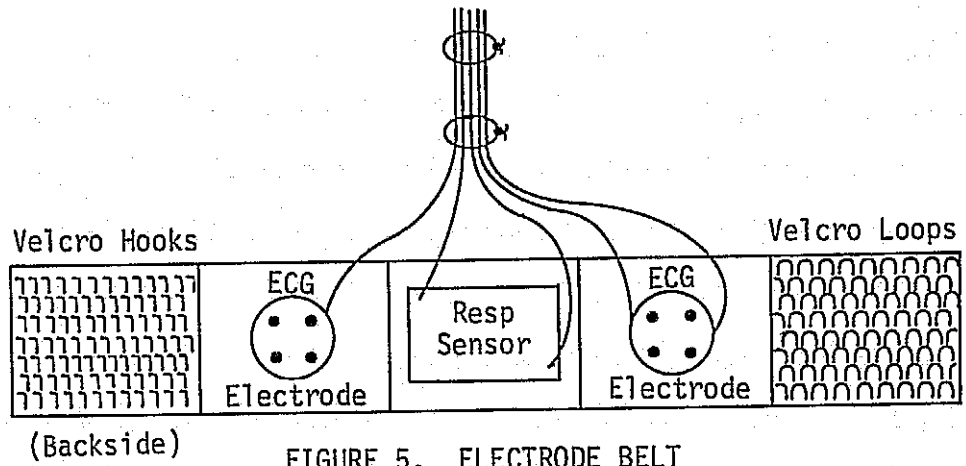

FIGURE 5. ELECTRODE BELT STRUCTURE



FIGURE 6. LATERAL AND TOP VIEW OF ECG ELECTRODE

Cage Temperature

A non-linear thermistor, "400" Series, Yellow Springs Instrument Co., was used to sense cage temperature. The original design range was 10°C to 65°C. A constant d.c. current is passed through the thermistor, the resultant voltage is amplified and conditioned to be compatible with the FM magnetic tape recorder. A positive 1.4 vdc corresponds to 10°C and 65°C is indicated by a negative 1.4 vdc. A calibration curve of voltage vs temperature for use in data reduction is in Figure 1 of the Appendix.

After the Boeing test in which the cage temperature reached approximately 92°C, the temperature range was expanded to record from 0°C to 100°C although the calibration record remained the same. The circuit diagram for this portion of the instrumentation is seen in Figure 2 of the Appendix. Figure 3 is the calibration curve for the 0°C to 100°C range.

Electrocardiogram

The ECG signal conditioner amplifies frequencies from 1.0 Hz to 2000 Hz in order to provide complete recording of the rat cardiac frequencies. The signals are amplified about 4000 times (72 dB) and adjusted to the tape recorder input levels (± 1.4 vdc). Figure 4 in the Appendix illustrates the circuit diagram for ECG. The ECG pre-amplifier consists of a transistor differential input stage to achieve high input impedance and low noise. Operational amplifiers are used in the output to increase signal level.

Respiration

The frequency design range for respiration is from 0.5 Hz to 500 Hz. Figure 5 of the Appendix shows the circuit diagram for the respiratory electronics. Respiration is measured with a piezo-electric transducer mounted in the electrode belt. The transducer is responsive to expansion and contraction of the rib cage. Signal conditioning electronics consist of an impedance buffer which isolates the transducer from the low impedance recorder and signal amplification to provide proper signal level to the tape recorder. Figure 7 in the text illustrates typical laboratory recordings of ECG and respiration.

Subject Activity

The original concept for monitoring physical activity of the mice in the second compartment was simply to record their activity via cinematography or video-tape. In the Boeing test, an exercise wheel and a teeter-totter were provided. The wheel was used vigorously by the S_s, but the teeter-totter appeared to be of little value. One of the simplest methods was found to be observation of the S_s climbing to the top of the cage. S's inability to maintain the inverted position and falling to the cage floor appears to be an adequate endpoint for functionability. Videotape recording of this test was quite useful for monitoring activity.

During the development of the electrode belt and during the Boeing test, it was found that the ECG and respiratory records were very useful in indicating the relative level of physical activity of the rat by the noise level generated in the ECG by his movements. The noise shown in the recording is roughly proportional to the degree of activity. Indications are (unverified as yet) that terminal spasticity and convulsions can be identified also. Additional research will be needed for verification.

Figure 7 shows the high-quality ECG, respiration and electromyographic records obtained in the laboratory.

In the Appendix, Figure 6 shows the cables (inside and outside) schematics; Figure 7, the power supply and Figure 8, the AETS system circuitry.

Recording

ECG, respiration and cage temperature are recorded on any standard multi-channel magnetic tape recorder. In the Douglas Biomedical Laboratory, a Precision Instrument 7-channel 1.27 cm (1/2-inch) FM tape recorder at 19.05 cm/s (7-1/2 ips) is used. At Boeing a standard 2.54 cm (1-inch) FM tape recorder at 38.1 cm/s (15 ips) was used to be compatible with their data acquisition system. The tapes are returned to the Douglas Biomedical Laboratory, reproduced on the 8-channel strip chart of a Beckman Type SII Dynagraph Recorder utilizing 4 channels to record ECG, unfiltered respiration, filtered respiration, and cage temperature (Figure 9). The temperature channel is used to indicate various events, e.g., start of test, ignition and other physical events by utilizing the T° calibrate/operate switch on the electronics box and a code developed for this purpose.

Data Analysis

Physiological and temperature data are analyzed from the strip chart. Parameters examined and end-points observed include changes in heart rate (HR), such as bradycardia (slow HR), cardiac arrhythmias and arrest, respiratory pattern changes, changes in respiratory integration time and respiratory arrest. Physical activity of the instrumented subject is also observed as EMG noise in the ECG baseline and this has been observed as being roughly proportional to the level of activity.

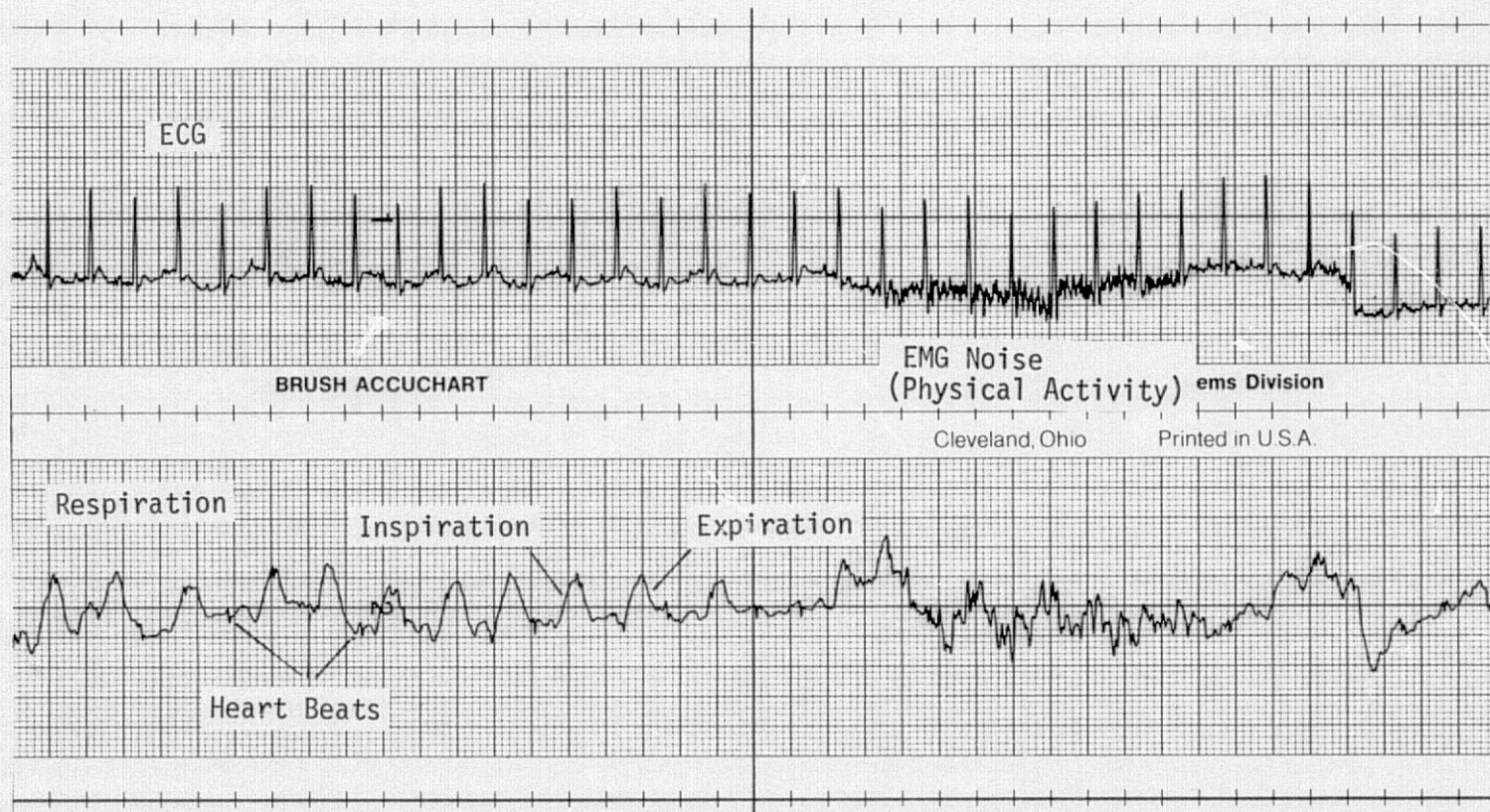

FIGURE 7. LABORATORY RECORDINGS OF ECG AND RESPIRATION ILLUSTRATING EMG

RESULTS

On June 3, 1975, in preparation for the Boeing test on June 11, 1975 at Seattle, an AETS checkout test was run in the MDC Cabin Fire Simulator (CFS) facility at A3 (Huntington Beach). The fire source was 4.55 Kg (ten pounds) of shredded newspaper contained in two expanded metal baskets and ignited by means of a nichrome wire inserted into the basket located on the floor. The AETS was outside the simulated marsonite lavatory and connected with the lavatory enclosure by a 1.9 cm (3/4 inch) flexible hose approximately 38.1 cm (15 inches) long. The duct entered the AETS through a connector in the sealed plastic (polyethylene) covering of the cage, making it into a closed system for this test. The effluent duct discharged into the exhaust duct from the lavatory enclosure. The AETS air flow was regulated by the same exhaust pump and a control valve inserted into the effluent duct between the exposure cage and lavatory exhaust duct.

The AETS functioned as designed in this preliminary checkout test conducted in the MDC CFS.

The rat's responses to the fire gases are evident in 1.3 minutes after ignition. Cardiac arrhythmias continue for 4-5 minutes. At ten minutes into the test the fire was extinguished by flooding the compartment with nitrogen (N₂). Again, severe bradycardia and arrhythmias occurred in about one minute after N₂ was introduced. Hypoxia was undoubtedly a major factor in producing this effect. Cage temperature profile is shown in Figure 8. Table 2 summarizes the physiological effects and sequence.

The AETS was packed and transported to Boeing, Seattle on June 9, 1975, and the system prepared for the burn test on June 11, 1975. Checkout went smoothly until the subject chewed some of the electrode wires in two on the day of the test. Repairs were quickly made, and the system was again checked out and found to be working satisfactorily.

The test began on schedule and burned for the full allotted 30 minutes, then was extinguished with CO₂. Both rat and mice (in the activity side of the cage) died at approximately the 18th minute. All subjects were obscured by smoke at 16 minutes and the instrumented S's record indicated death at approximately 18 minutes. However, at about 12 minutes the mice were fairly incapacitated as indicated by their falling behavior in the wheel and by their dropping to the floor from the top of the cage. Table 3 summarized the physiological effects in this burn test. Figures 9 through 16 show the span from normal ECG and respiration to cardiac arrest, as a function of time. Fire gases and O₂ are shown in Figures 17 through 20 (9). Figure 21 shows the enclosure temperature. Figure 22 illustrates the arrangement of the "airline" type waste used as an ignition source and Figure 23 depicts the position and general arrangement of the AETS. The correlation of the physiological effects and the gas analysis data was reported in a "Special Report of the Boeing Test on 11 June 1975", dated 5 August 1975, a copy of which is included in the Appendix of this report for sake of completeness.

AETS CAGE CFS BURN TEST - 3 JUNE 1975, 1600 HOURS
FIRE SOURCE: 4.55 Kg (10 LB) SHREDDED NEWSPAPER

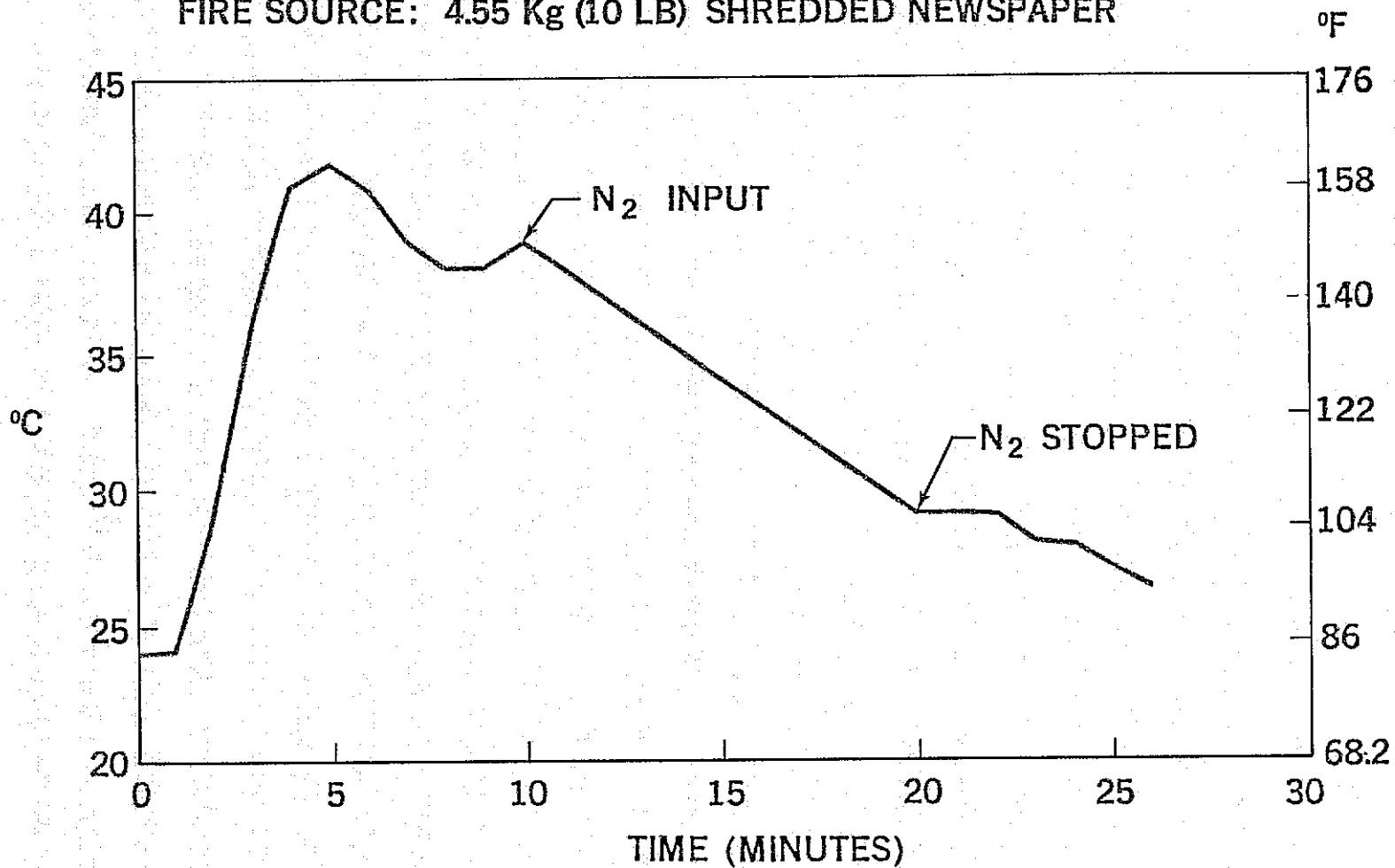

FIGURE 8. TEMPERATURE PROFILE,
CFS TEST

<u>PHYSIOLOGICAL EFFECT</u>	<u>MINUTES INTO TEST</u>
CARDIAC ARRHYTHMIA BEGAN AT	1.3
BRADYCARDIA (SLOWING OF HEART RATE) FROM 520 BPM TO 110 BPM NORMAL RATE \approx 400-450	1.5
HEART RATE (H.R.) FASTER AND IRREGULAR	2.6
H.R. MORE REGULAR	5.5
TEST FIXTURE FLOODED WITH LIQUID N ₂	10.0
MARKED BRADYCARDIA AND ARRHYTHMIA	11.0
HIGH RESPIRATORY AND PHYSICAL ACTIVITY	11.5
BRADYCARDIA AND ARRHYTHMIA	13.5
HIGH H.R. WITH ARRHYTHMIAS	17.0
STOPPED N ₂ INFLOW	20.0
HIGH RESPIRATORY AMPLITUDE	20.5
CARDIAC RHYTHM RECOVERING	25.0
SUBJECT REMOVED. SURVIVED, IN FAIR CONDITION	27.0

TABLE 2. CFS PHYSIOLOGICAL
DATA SUMMARY

<u>ECG/RESPIRATION</u>	<u>MINUTES INTO TEST</u>
FIRST ARRHYTHMIA (SKIPPED BEAT)	7.65
FOURTEEN MORE SKIPPED BEATS BY	9.0
TWO MORE SKIPPED BEATS BY	10.0
ECG AMPLITUDE DIMINISHED	10.0
BRADYCARDIA AND RESPIRATORY ARREST	17.0
CARDIAC ARRHYTHMIAS, MARKED BRADYCARDIA, SPORADIC ARREST FOR 2-7 SECONDS	17.25
PERMANENT CARDIAC ARREST	18.0

THE ECG AND RESPIRATORY RECORDS ALSO APPEARS TO REFLECT PHYSICAL ACTIVITY OF THE INSTRUMENTED SUBJECT.

* CAGE TEMPERATURE WENT OUT OF SCALE. MAXIMUM TEMPERATURE DESIGNED FOR WAS 65° C. BOEING RECORD SHOWED 196° F (91° C) .

TABLE 3. BOEING TEST
PHYSIOLOGICAL DATA
SUMMARY

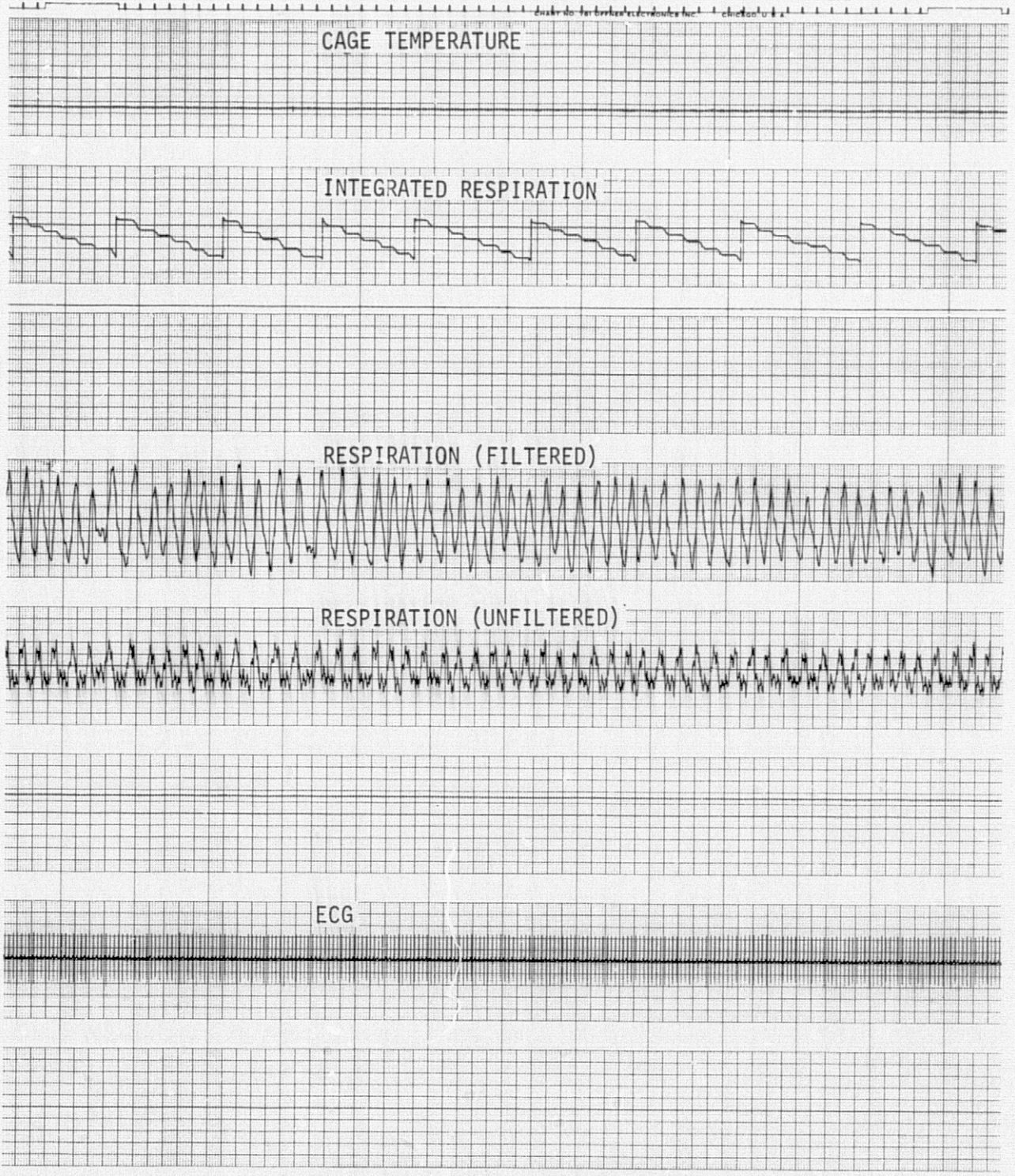

FIGURE 9. REPRODUCED BOEING
TEST PHYSIOLOGICAL
DATA

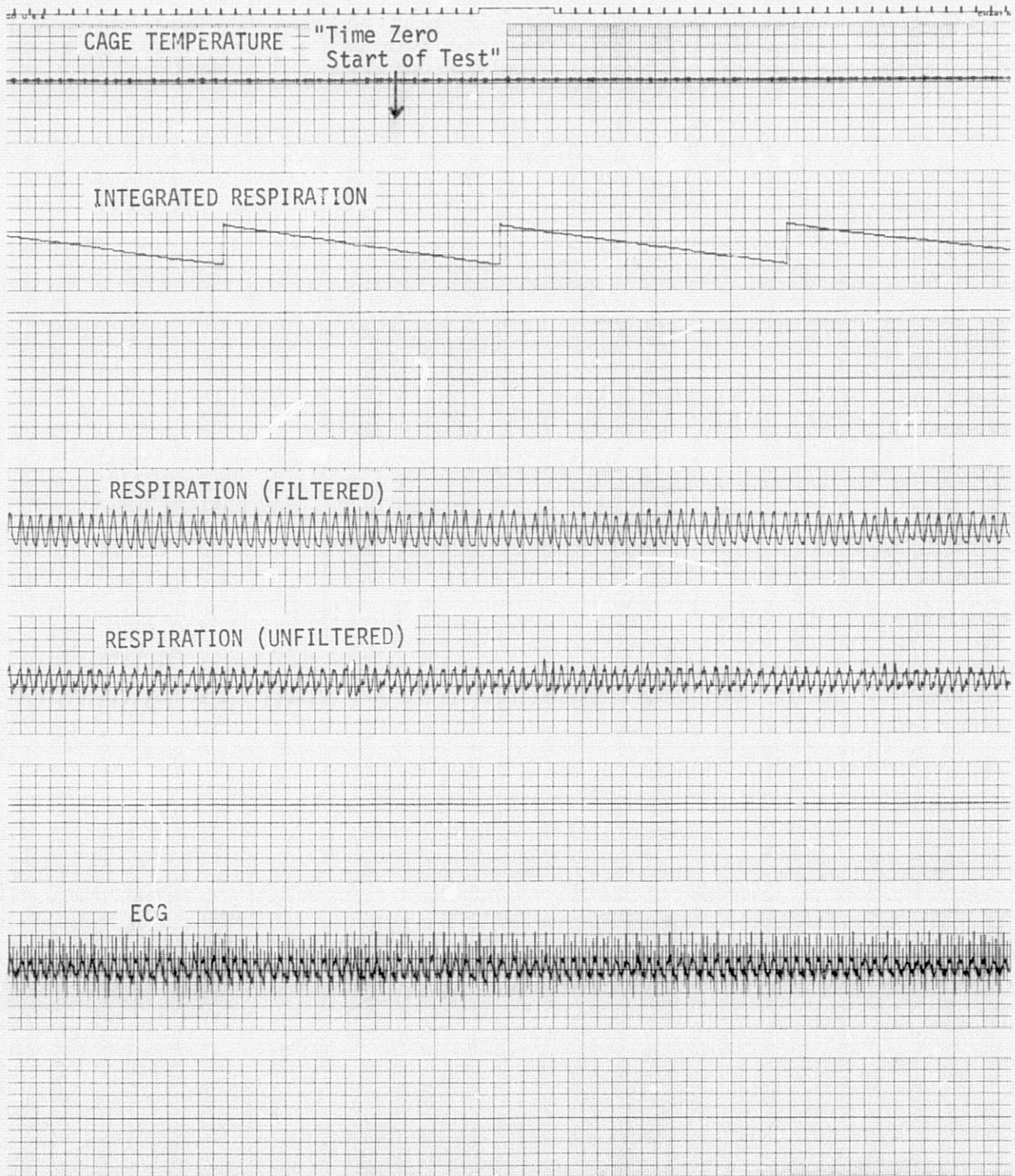

FIGURE 10. REPRODUCED BOEING TEST PHYSIOLOGICAL DATA

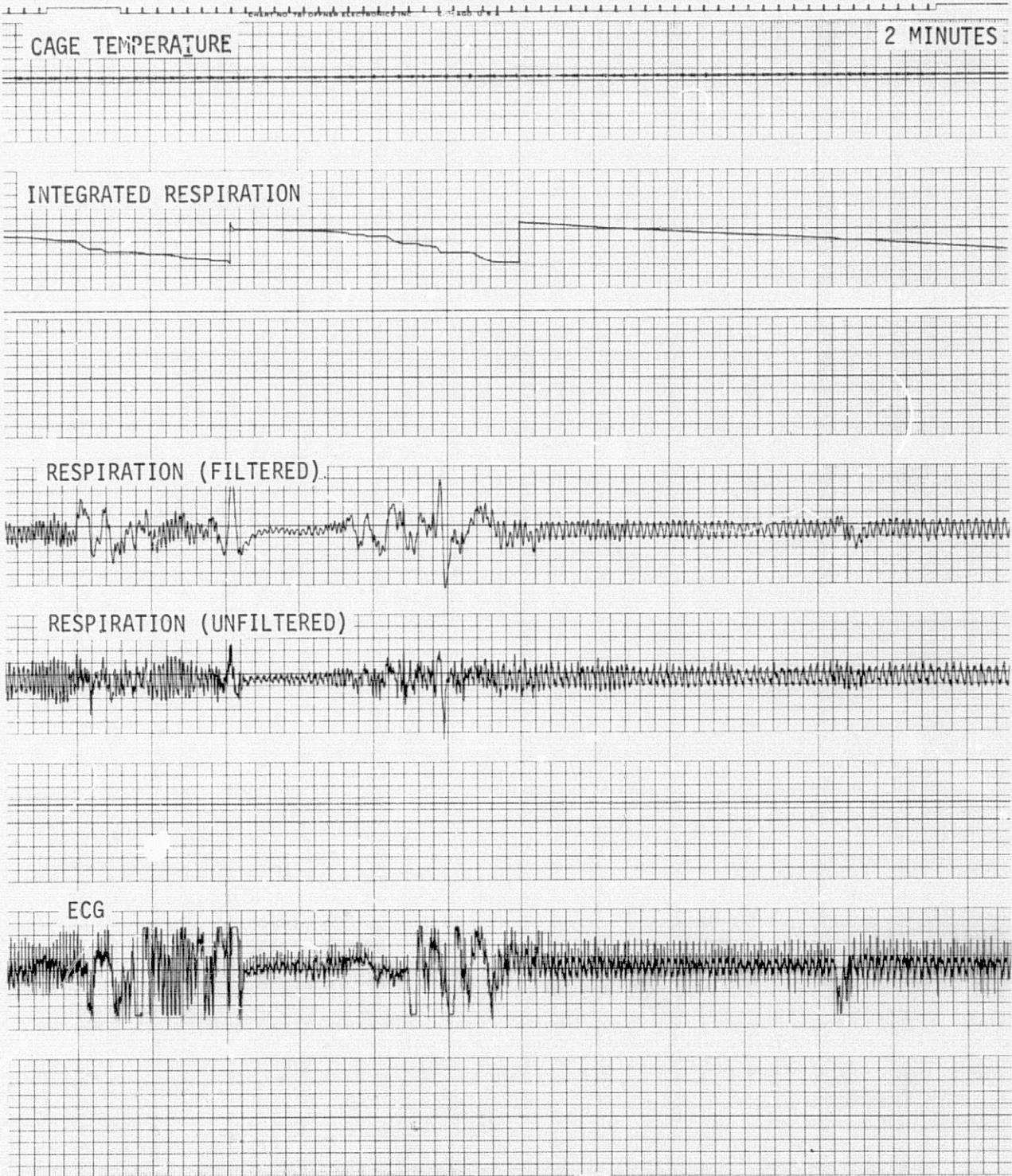

FIGURE 11. REPRODUCED BOEING
TEST PHYSIOLOGICAL
DATA

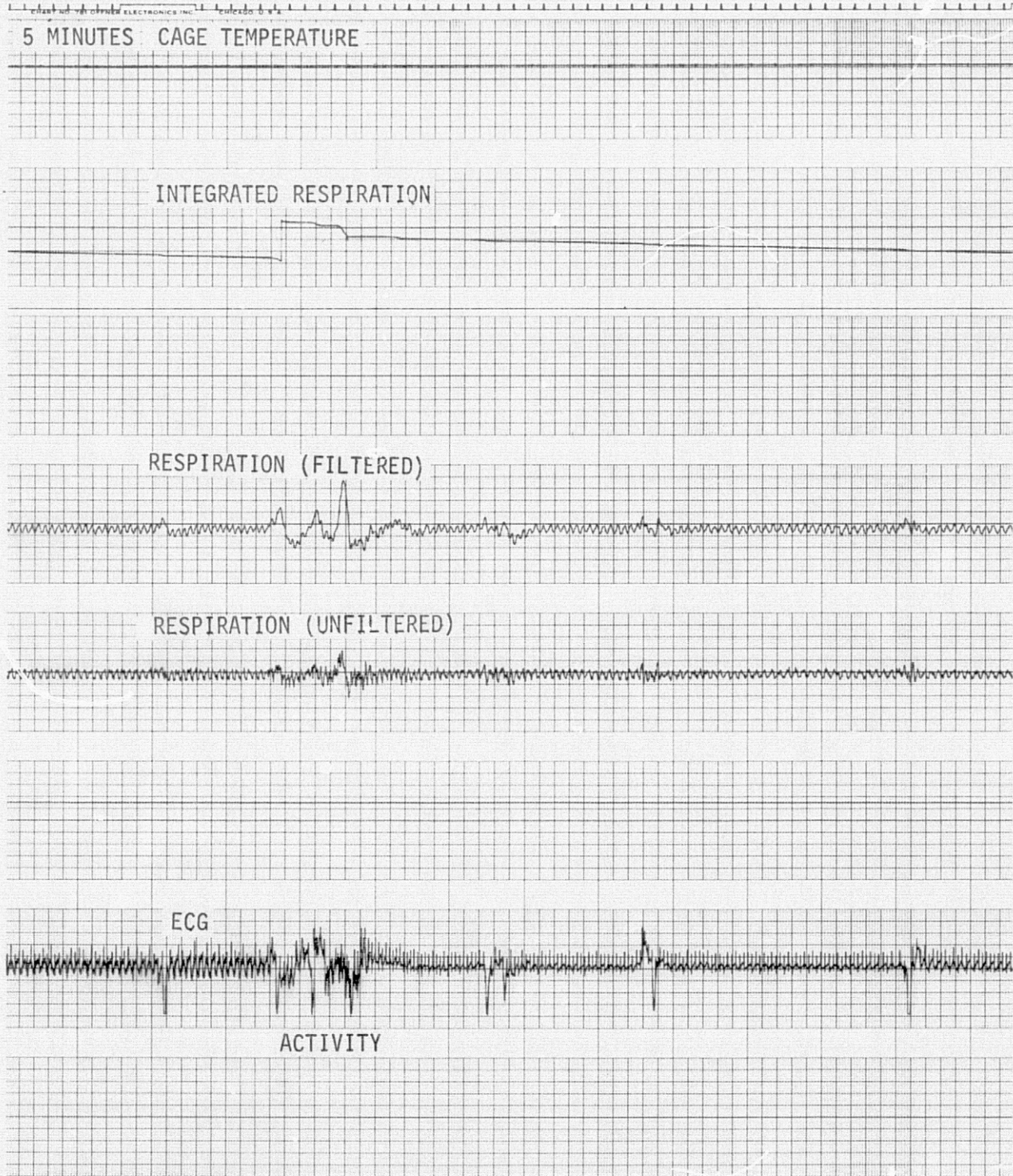

FIGURE 12. REPRODUCED BOEING TEST PHYSIOLOGICAL DATA

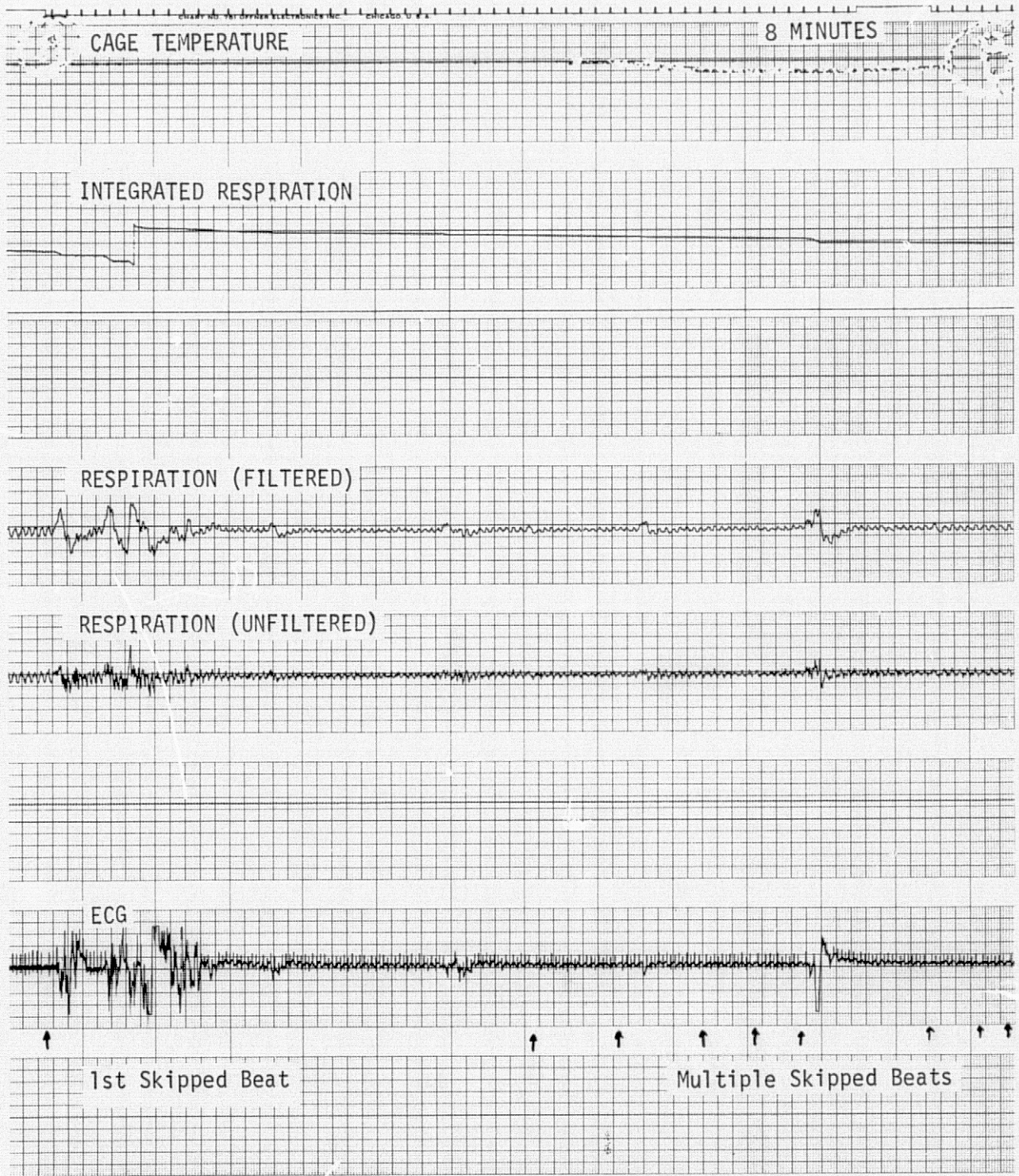

FIGURE 13. REPRODUCED BOEING TEST PHYSIOLOGICAL DATA

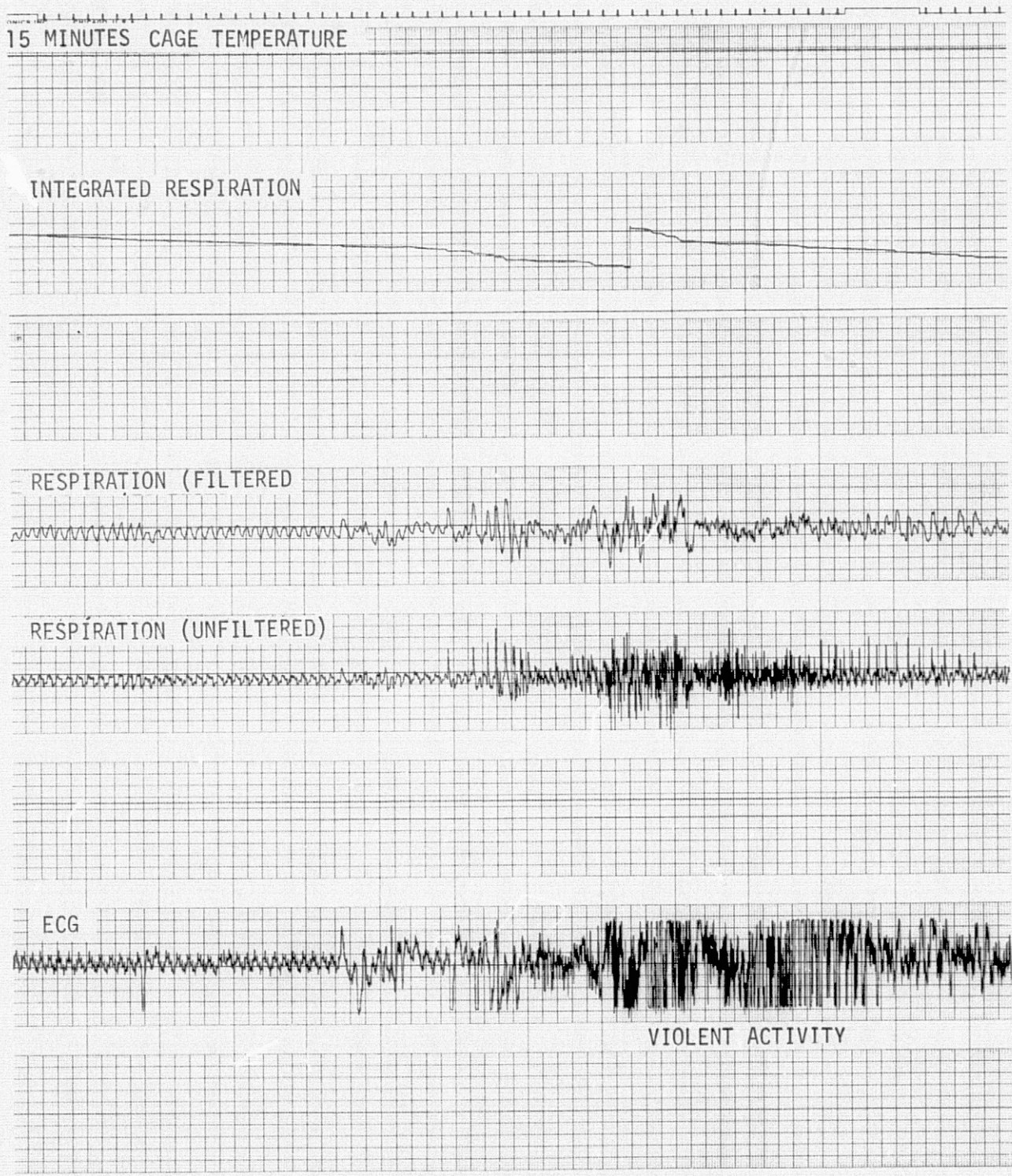

FIGURE 14. REPRODUCED BOEING TEST PHYSIOLOGICAL DATA

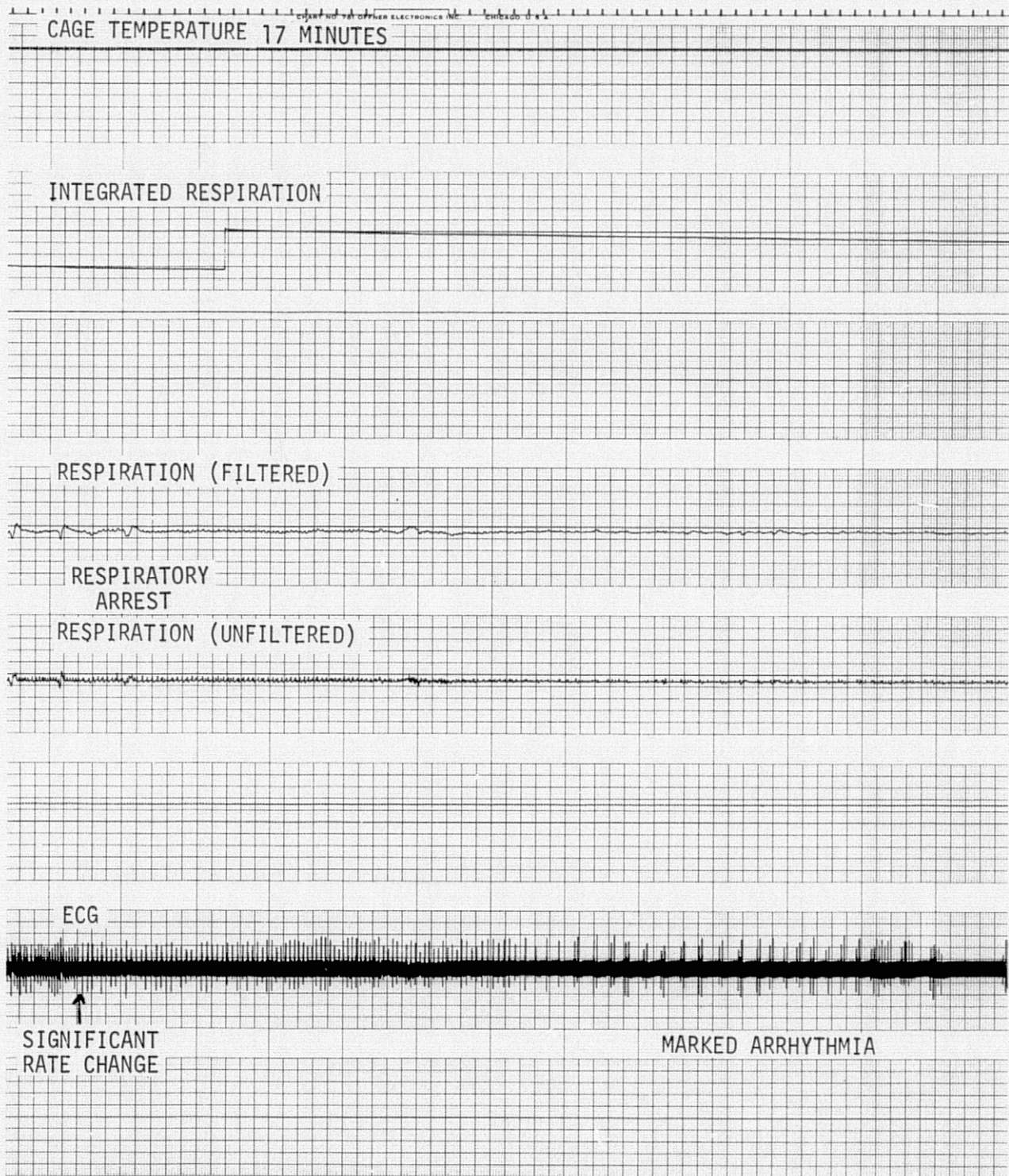

FIGURE 15. REPRODUCED BOEING TEST PHYSIOLOGICAL DATA

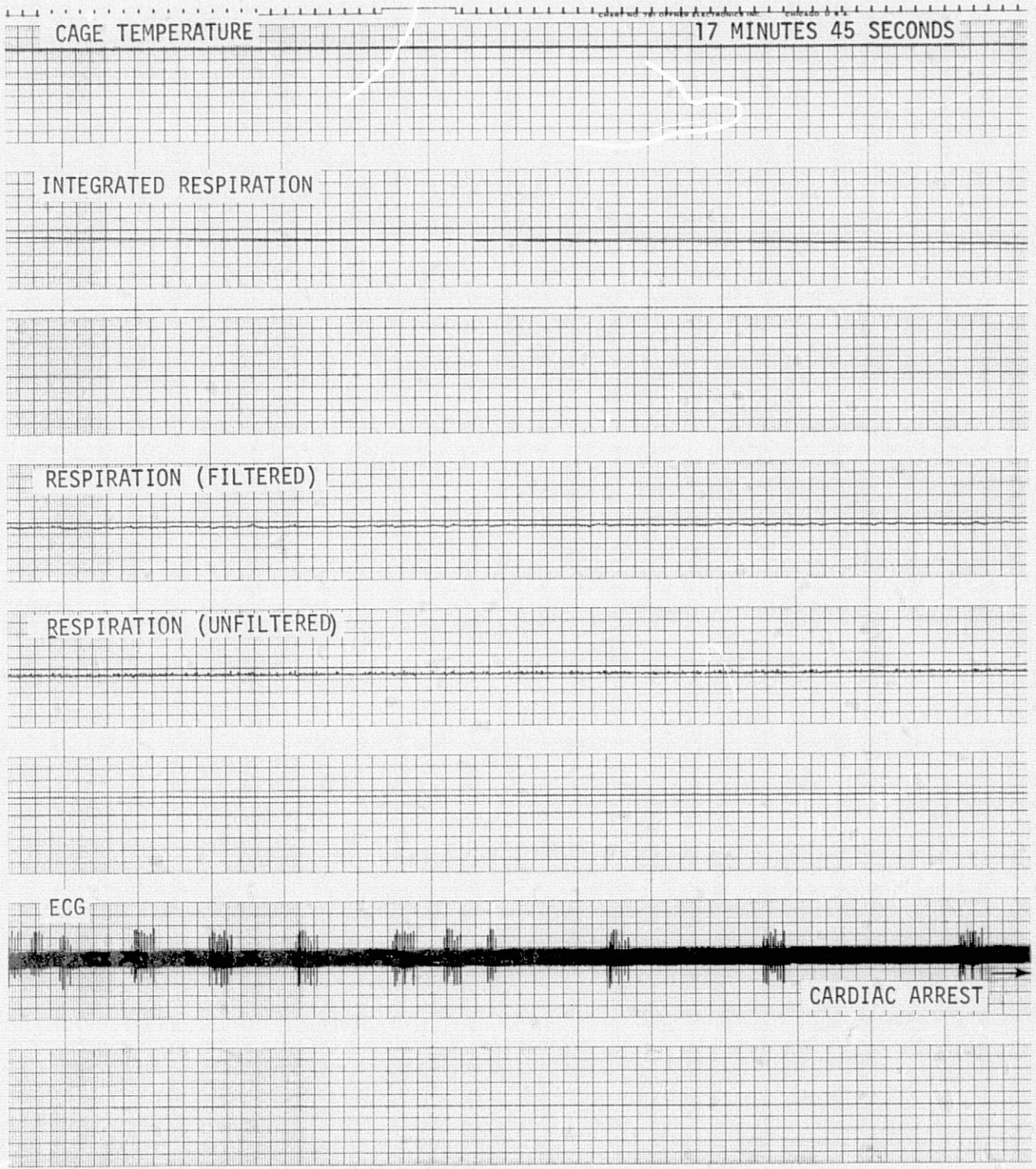

FIGURE 16. REPRODUCED BOEING
TEST PHYSIOLOGICAL
DATA

Other Tests

Two other burn tests were conducted at the University of California-Richmond Field Test Station, one on 7 November and one on 13 November. During the interval between the Boeing test on 11 June 1975, and the 7 November test at UCB-Richmond, the AETS cage was re-designed and fabricated as two separate cages, each 24.13 cm (9.5 inch) cube of 0.635 cm (1/4 inch) hardware cloth. The two cages can be stored flat in a space 25.4 x 25.4 x 7.62 cm (10 x 10 x 3 inches). Each is assembled and ready for use in a few minutes, utilizing spirally-wound wire as fasteners. No tools are required for assembly. The assembled cage is quite rigid and sturdy for its weight. Disassembly and packing for transport also requires no tools and only a few minutes.

In the 7 November test the exposure was brief. The S was obscured by smoke in about 2-1/2 minutes. The physiological effects were minimal, consisting of a mild bradycardia (H.R. dropped from 510 bpm to about 350 bpm) and a reduced respiratory amplitude. Occasional arrhythmias were observed in this test. The S was quite vigorous on removal from the exposure cage, and had no significant sequelae. Cage temperature was not excessive. The Mark II cage was satisfactory and was certainly much easier to transport to the test site.

During the 13 November test, ECG and respiration data were lost. Good cage temperature data was obtained however, and is shown in Figure 24. This temperature curve indicates that the S was in a temperature environment of more than 60°C (140°F) for 6 minutes or more with a peak temperature of 73°C (163.5°F) and in the presence of severe fire gases. This S was obscured by heavy black smoke in one and one-half minutes. He offered little resistance on removal from the exposure cage. On return to the holding cage, the S huddled in the corner as if reluctant to move. On the following morning, he appeared listless, with respiration somewhat labored.

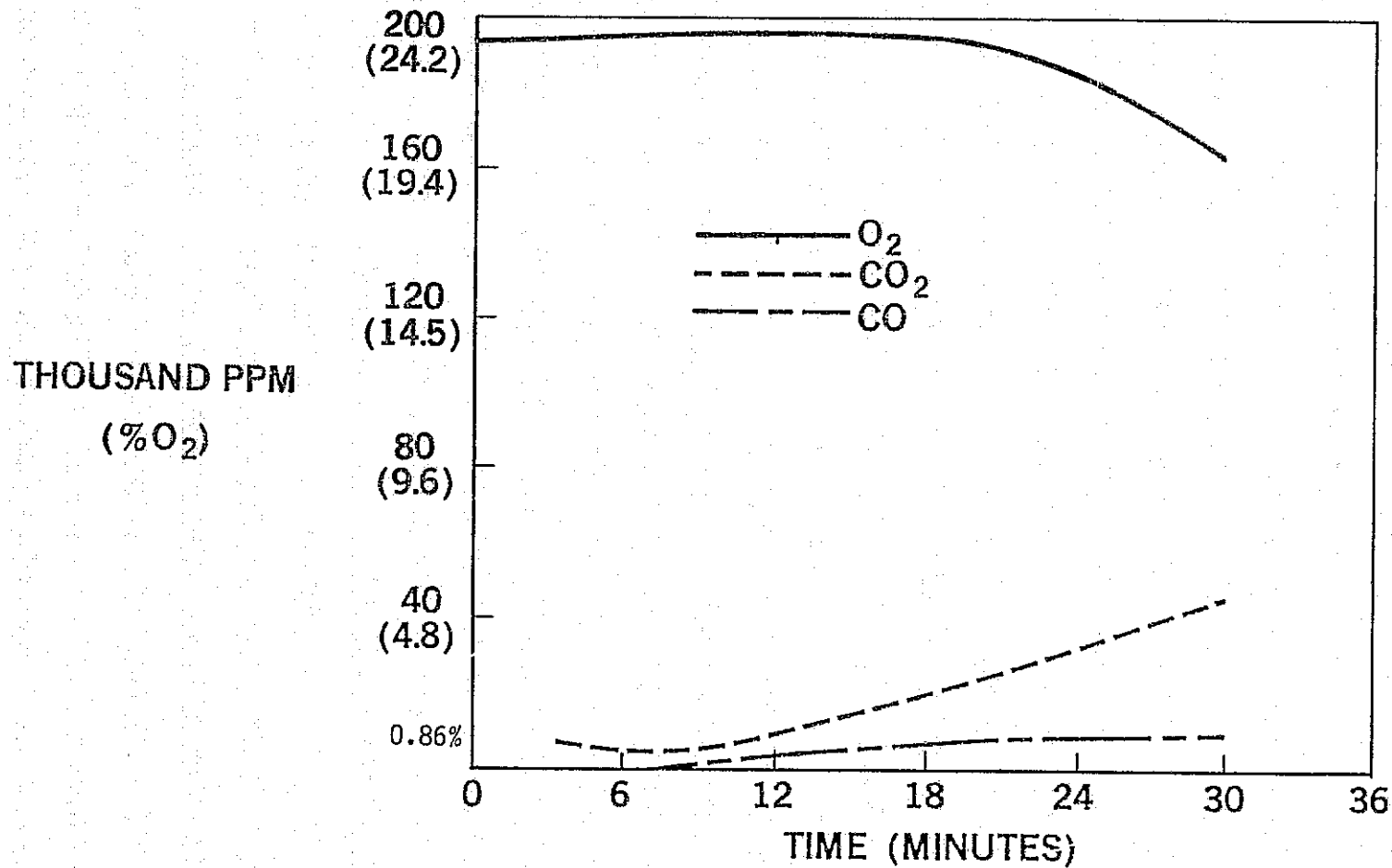

FIGURE 17. BOEING TEST DATA
MAJOR GASES IN
ENCLOSURE

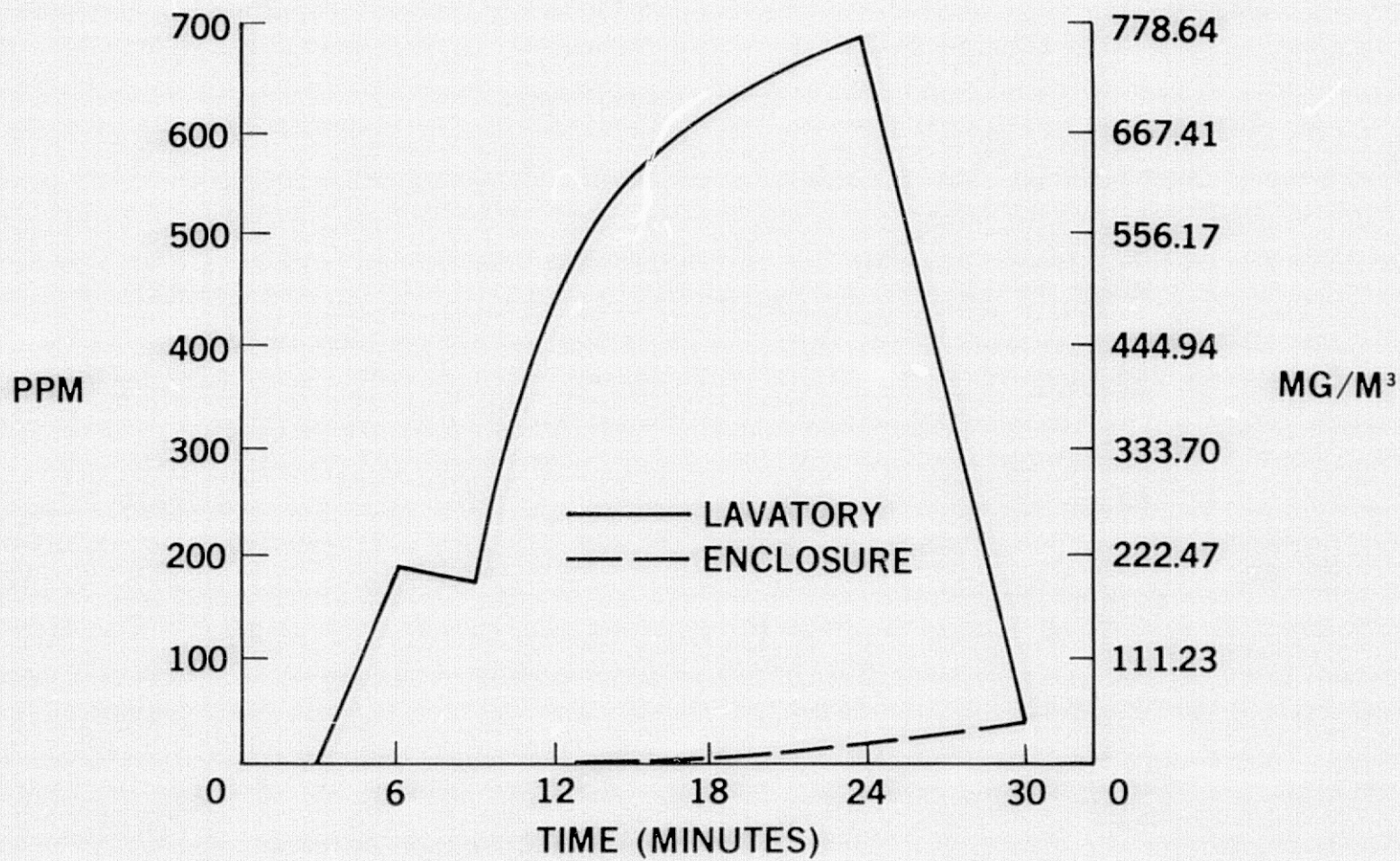

FIGURE 18. BOEING TEST DATA
CONCENTRATION OF HCN

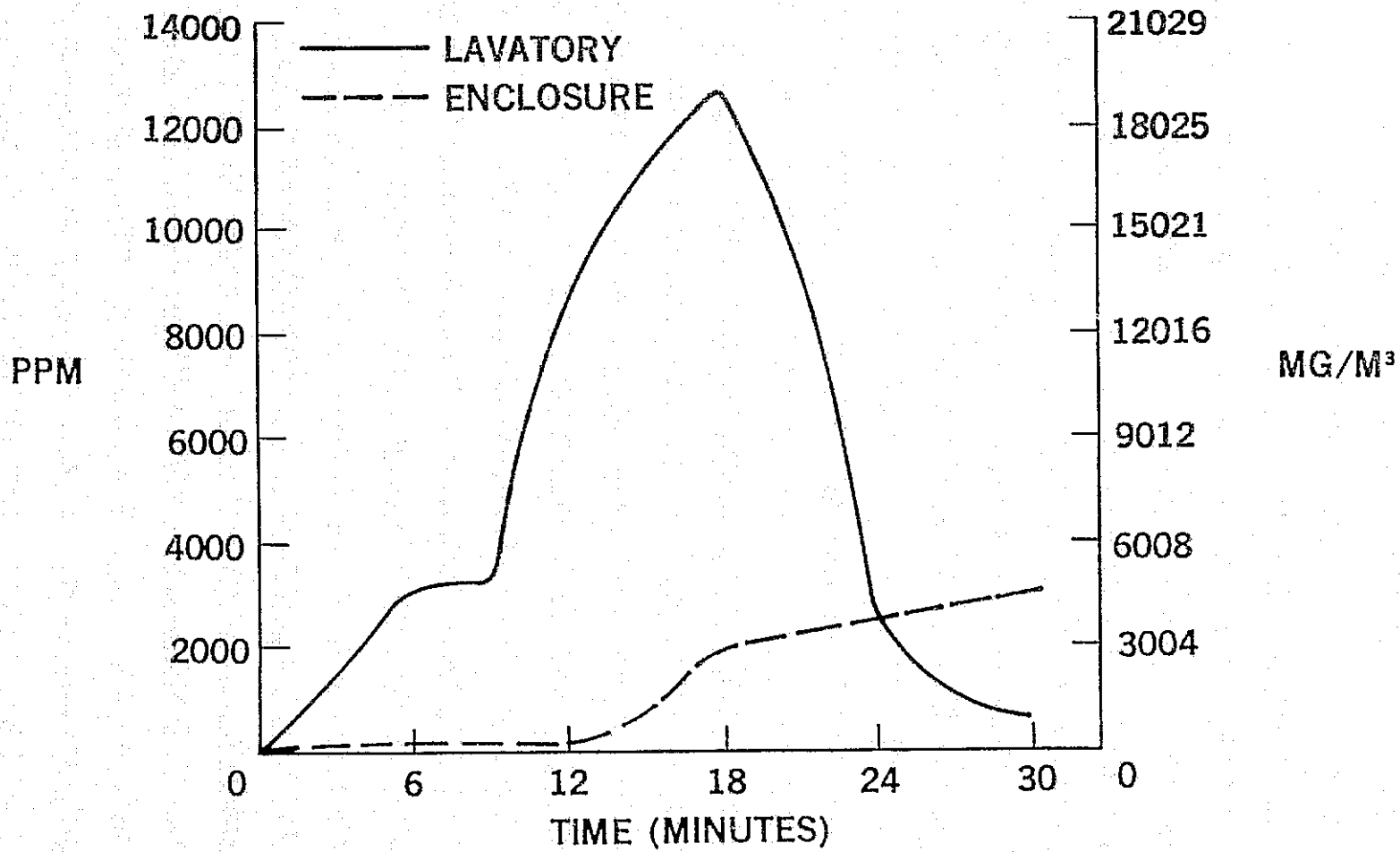

FIGURE 19. BOEING TEST DATA
CONCENTRATION OF HCl

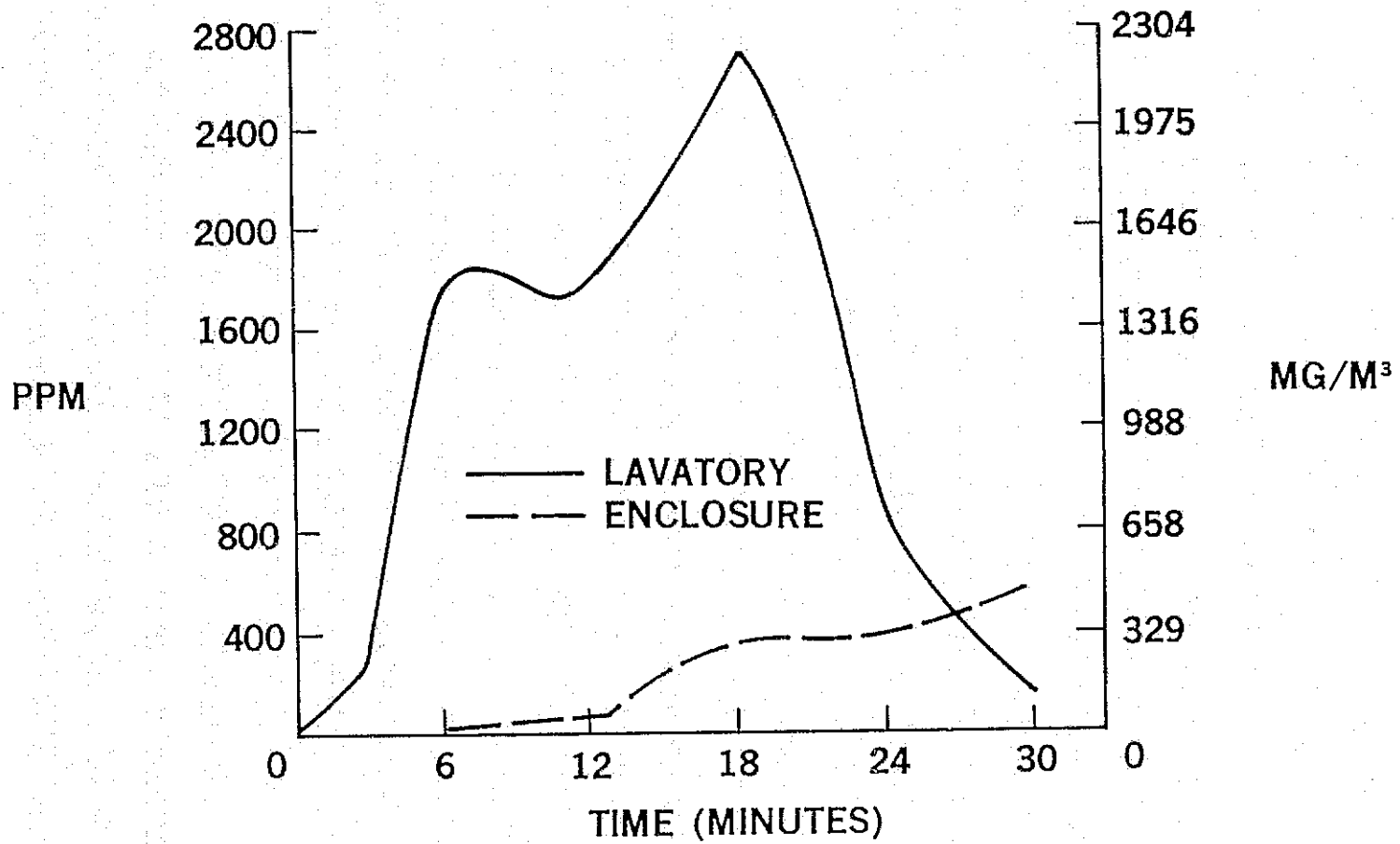

FIGURE 20. BOEING TEST DATA
CONCENTRATION OF HF

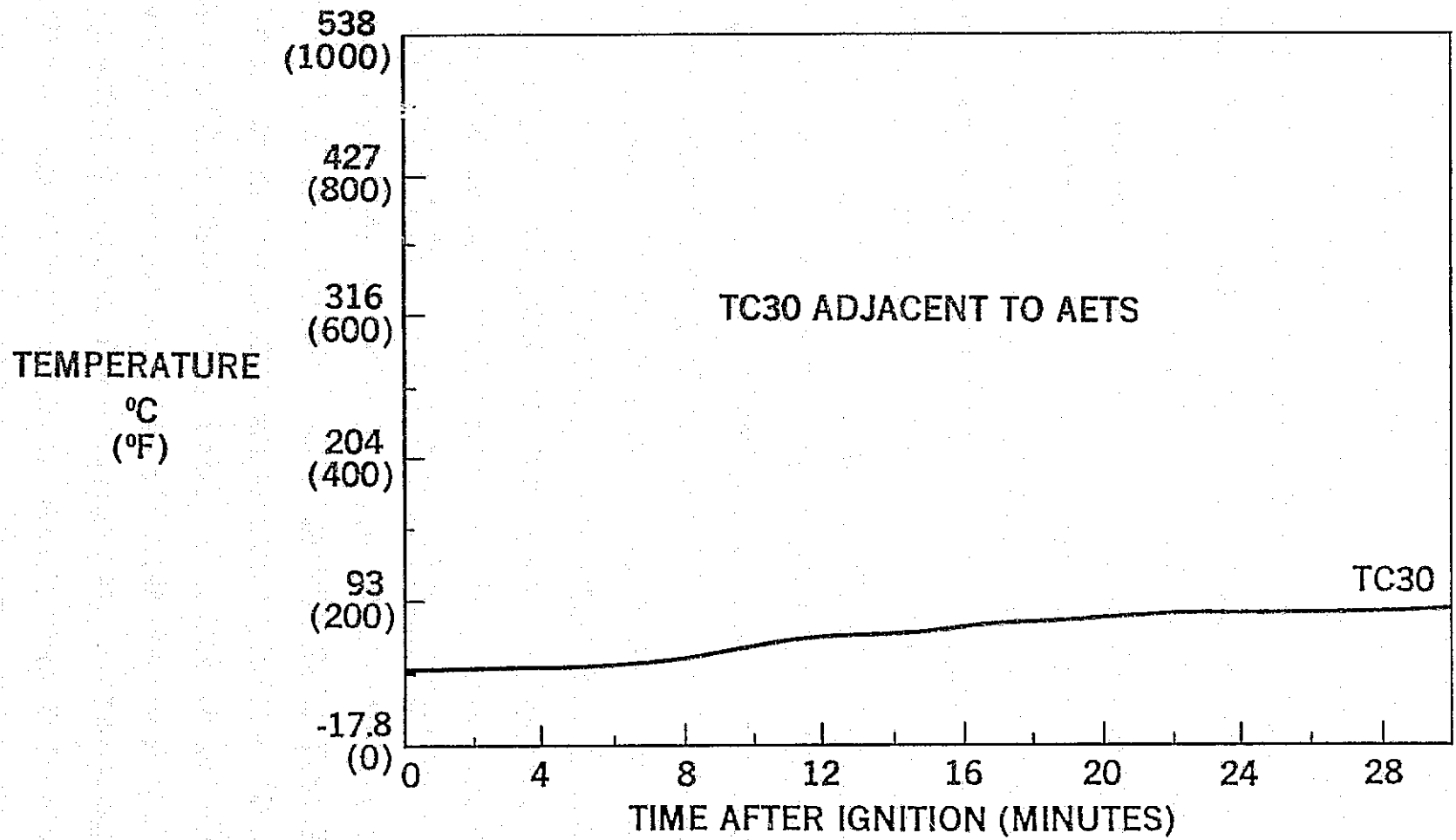

FIGURE 21. BOEING TEST DATA
AIR TEMPERATURE IN
ENCLOSURE

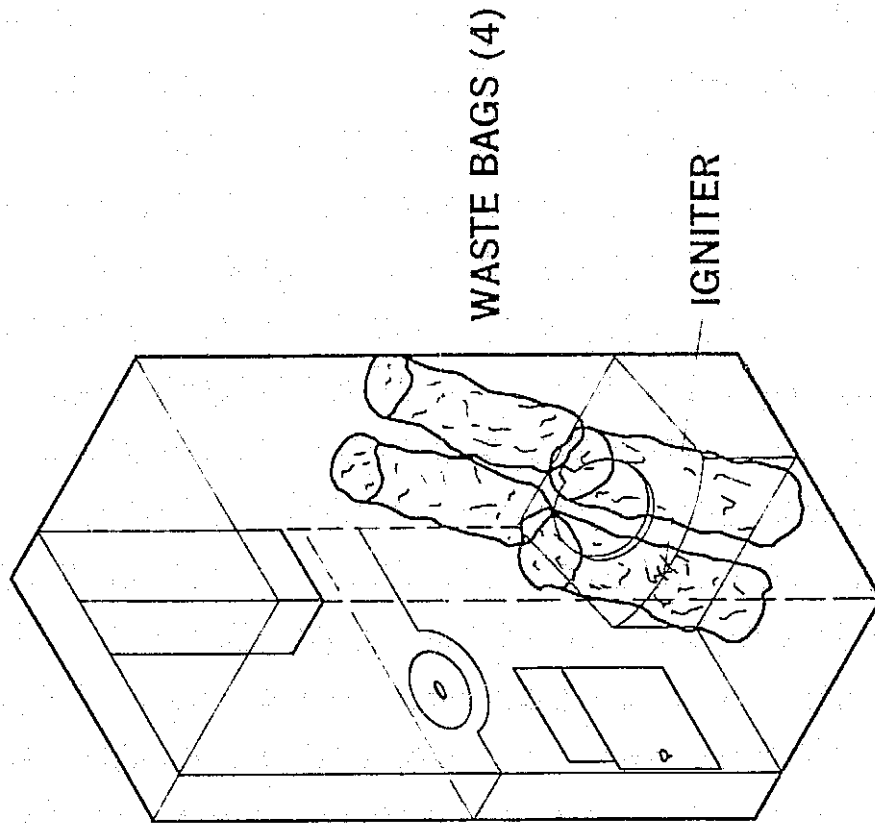

FIGURE 22. FUEL SOURCE FOR BOEING TEST

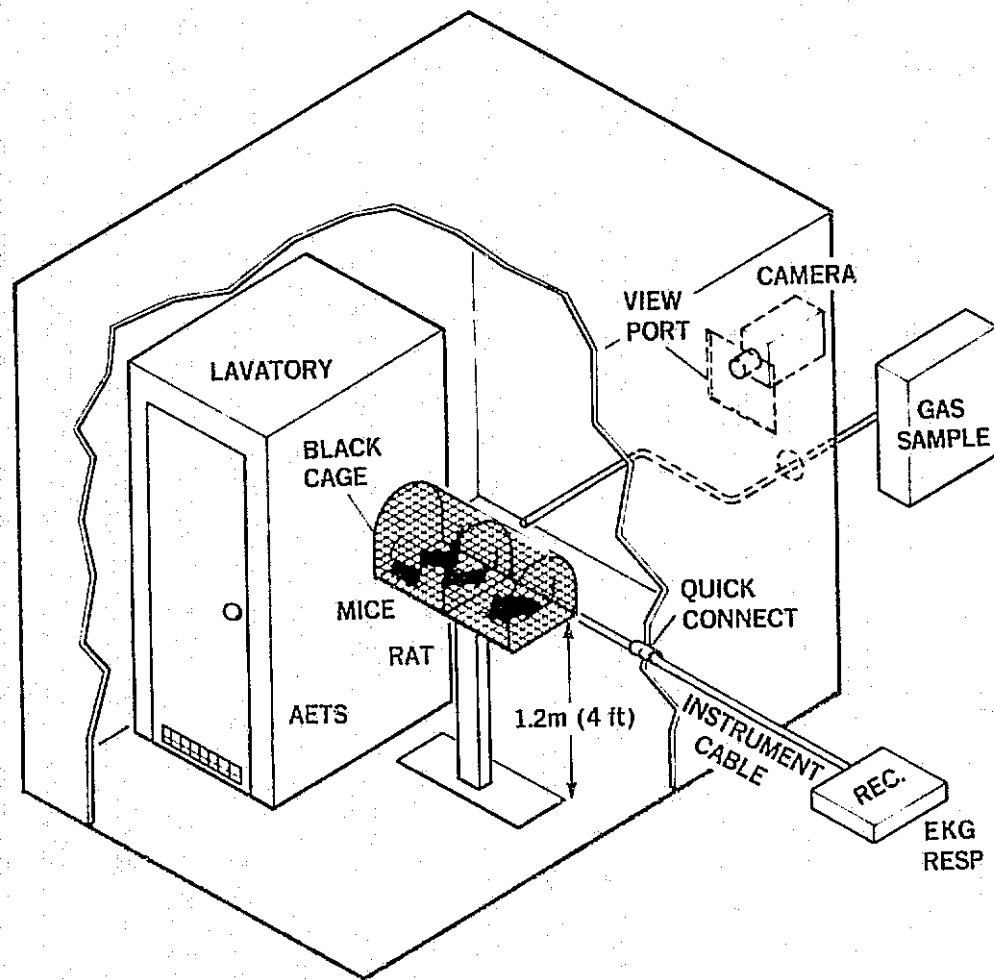

FIGURE 23. PLACEMENT OF AETS FOR BOEING TEST

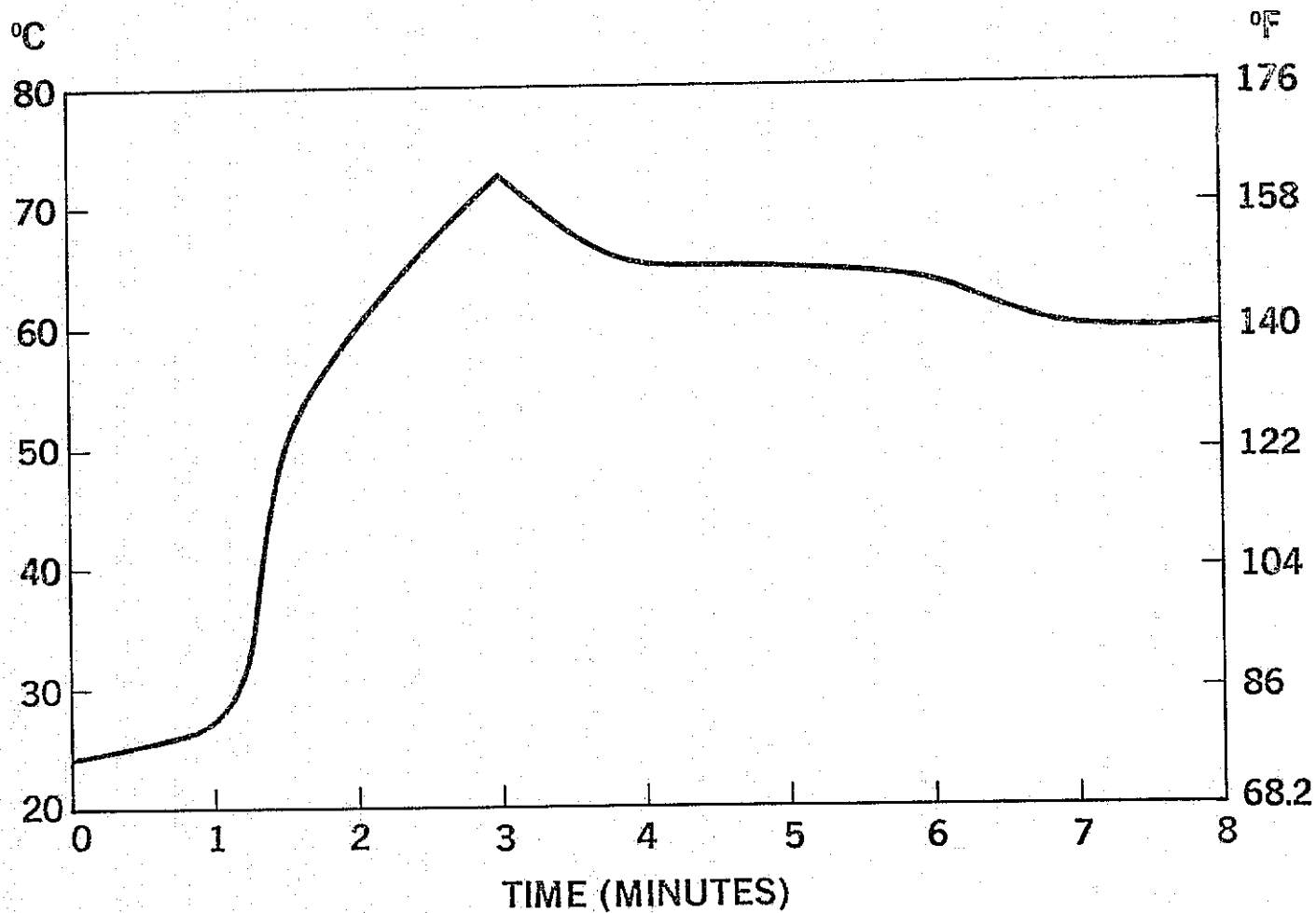

FIGURE 24. UCB RICHMOND TEST DATA
AETS TEMPERATURE
PROFILE

DISCUSSION

The physiological responses which have been observed in the instrumented subject in these tests, principally in the Boeing test and in the prior MDC CFS test, include:

1. Cardiac responses - bradycardia (slow heart rate), arrhythmias possibly of two or three types, and cardiac arrest.
2. Respiratory responses - reduction of amplitude, change of rate, reduction of minute volume.
3. Electromyographic responses (EMG) - of the torso. During physical activity of the subject, characteristic changes occur in the ECG baseline which have been related to muscle activity, in the laboratory and in the burn tests. Activity level can be estimated from the magnitude of EMG noise generated in the ECG record. It may be possible to identify convulsive activity, but this premise requires laboratory verification.

The activity responses observed in the mice in the second compartment of the Mark I cage were:

1. Vigorous activity, initially, on the exercise wheel and climbing the sides and under side of the cage mesh.
2. Stumbling and falling on the exercise wheel and riding up with the turning wheel nearly to the top of the turn. This effect was observed at approximately eleven minutes. This may be called the TUF.
3. Dropping from the underside of the cage top at approximately twelve minutes, apparently unable to muster the strength or coordination to hang on to the mesh as they had been doing. This may also be regarded as the TUF. Normally, these S_5 were able to climb up, over and down again with ease.
4. Convulsive jumping at approximately fifteen minutes.
5. Collapse and sporadic convulsions at sixteen minutes (observed after 16 minutes).

The behavior of the mice follows the pattern observed by most investigators, is a valid and useful method of monitoring, and little more needs to be said about this aspect. However, the physiological records when correlated with specific events of the test such as temperature increase, the time of appearance of the various fire gases (see Special Report, Appendix), and their rise in concentrations in time, give rise to certain questions regarding the physiological mechanisms of the recorded responses. Some questions are raised

PRECEDING PAGE BLANK NOT FILMED

regarding the mechanisms of similar cardiac responses when the S_5 are exposed to fire gases, simple hypoxia, or various extinguishing agents such as nitrogen, CO_2 , and the Halons. Why do all these different species produce cardiac effects that are so similar? Are the responses mediated by the same or different physiological mechanisms? And what are the mechanisms involved?

In the Boeing test the responses appeared to correlate with the build-up of HF and HCl in the enclosure. There was no O_2 deficit in the enclosure, so if hypoxia were the basic cause of cardiac effects, it probably was due to the presence of fire gases, or greatly diminished respiration from the irritating smoke, or both. Sporadic increases in respiratory rate and amplitude with or without an increase in physical activity, suggest that this may be the correct hypothesis. On the other hand, in the MDC CFS test, the rapidity of the onset of cardiac response, probably before hypoxia could have caused it, suggests that another mechanism may be in action. Other observations in MDC fire testing tends to support the latter hypothesis.

Other questions arise: Are the rats's cardio-respiratory responses similar to those expected in the human? Which is more responsive to these stimuli? Can the human response be scaled 1:1, or will it be different and in which direction?

CONCLUSIONS AND RECOMMENDATIONS

Some conclusions which can be drawn from this program are that:

1. The objectives of the effort have been fulfilled.
 - a. An animal exposure test system (AETS), capable of being standardized for universal use by many investigators, has been developed. Improvements in the basic system are possible, however.
 - b. By the use of this AETS, the relative toxicities of various materials under combustion or pyrolysis can be assessed to enable more judicious selection of materials for habitable spaces.

In addition, the methods used for recording and processing physiological data, have provided a simple means for rapid interpretation of data and correlation with the gas analyses data and the sequential test events.

Recommendations for future effort include:

1. Continue the development of the AETS to a higher level of proficiency, simplification, effectiveness, and portability.
2. Using the AETS and the TUF principles, continue to participate in as many fire tests as possible to build an adequate body of data on the physiological responses to fire gases for use in advanced materials selection.
3. Conduct well-planned laboratory experiments, utilizing the AETS recording and interpretation methods, with other appropriate procedures, to investigate the cardio-respiratory effects of fire gases, extinguishing agents, and simple hypoxia, singly and in various combinations, and the basic physiological mechanisms involved in these effects.

REFERENCES

1. Brice, H.W., "Methods for Combating Smoke", presented at International Symposium on Physiological and Toxicological Aspects of Combustion Products, Salt Lake City, Utah, March 1974.
2. Armstrong, G., "Synergistic Effects of Combustion Products", presented at International Symposium on Physiological and Toxicological Aspects of Combustion Products, Salt Lake City, Utah, March 1974.
3. Dorland's Illustrated Medical Dictionary, 24th Edition 1965, W.B. Saunders, Philadelphia.
4. Gaume, J.G. and P. Bartek, Theoretical Determination of the Time of Useful Function (TUF) on Exposure to Combinations of Toxic Gases. Aerospace Medicine 40:1353, 1969.
5. Bartek, P.; J.G. Gaume; H.J. Rostami, Dynamics Analysis for Time of Useful Function (TUF) Predictions in Toxic Combustive Environments. Aerospace Medicine 41:1392, 1970.
6. Gaume, J.G., P. Bartek, H.J. Rostami, Experimental Results on Time of Useful Function (TUF) after Exposure to Mixtures of Serious Contaminants. Aerospace Medicine 42:987, 1971.
7. Preliminary Plan for Fire Contaminant Test of Wide Body Airplane Lavatory Module, NASA ARC Moffett Field, California, April 1975.
8. Preliminary Plan for Fire Contaminant Test of Simulated Aircraft Lavatory, UCB-Richmond. NASA ARC Moffett Field, California, October 1975.
9. Kourtides, D.A., J.A. Parker, et al, "Fire Safety Evaluation of Aircraft Lavatory and Cargo Compartment" NASA Report No. TMX62471 August 1975.

PRECEDING PAGE BLANK NOT FILMED

APPENDIX

INSTRUMENTATION CIRCUIT DIAGRAMS

PRECEDING PAGE BLANK NOT FILMED

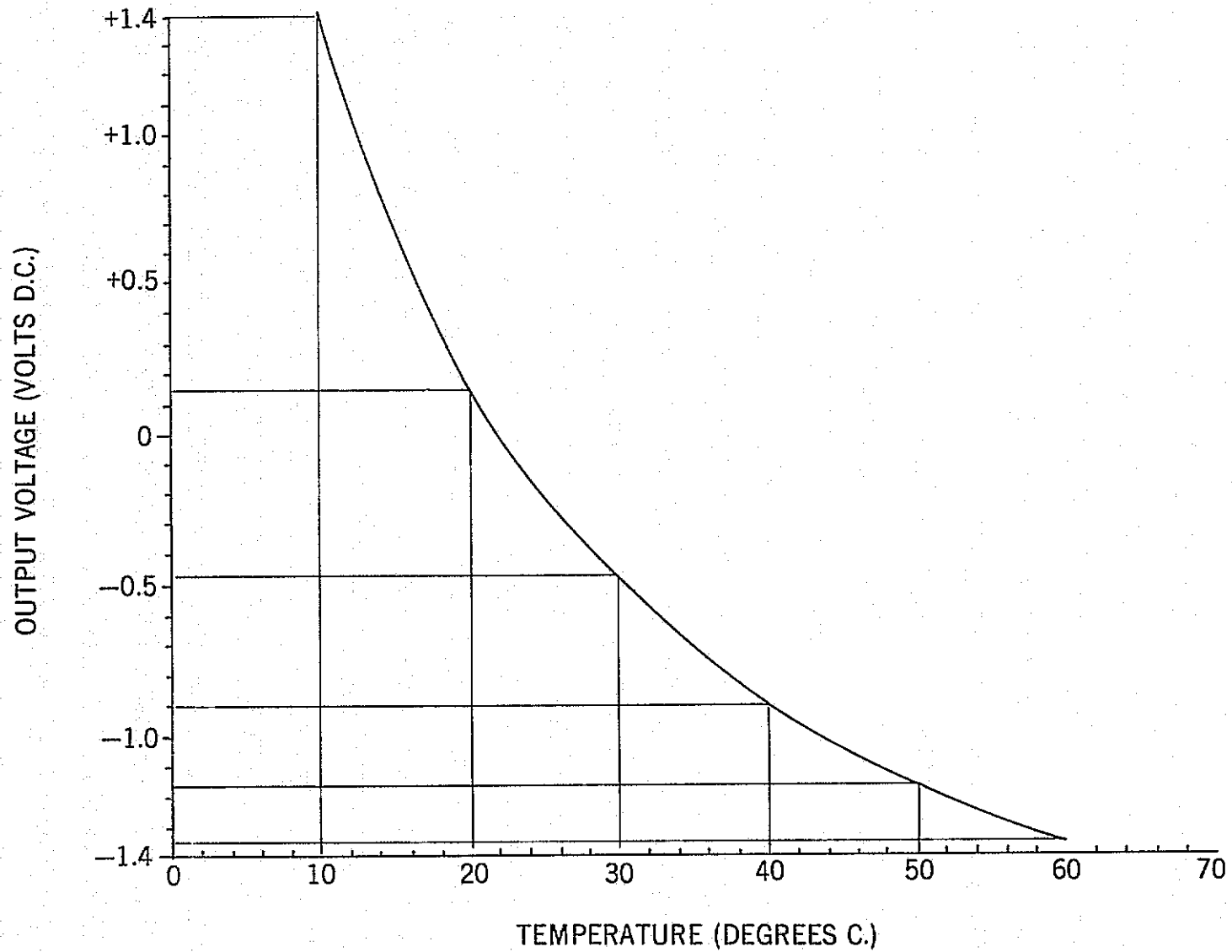

FIGURE 1 - THERMISTOR CALIBRATION ORIGINAL RANGE

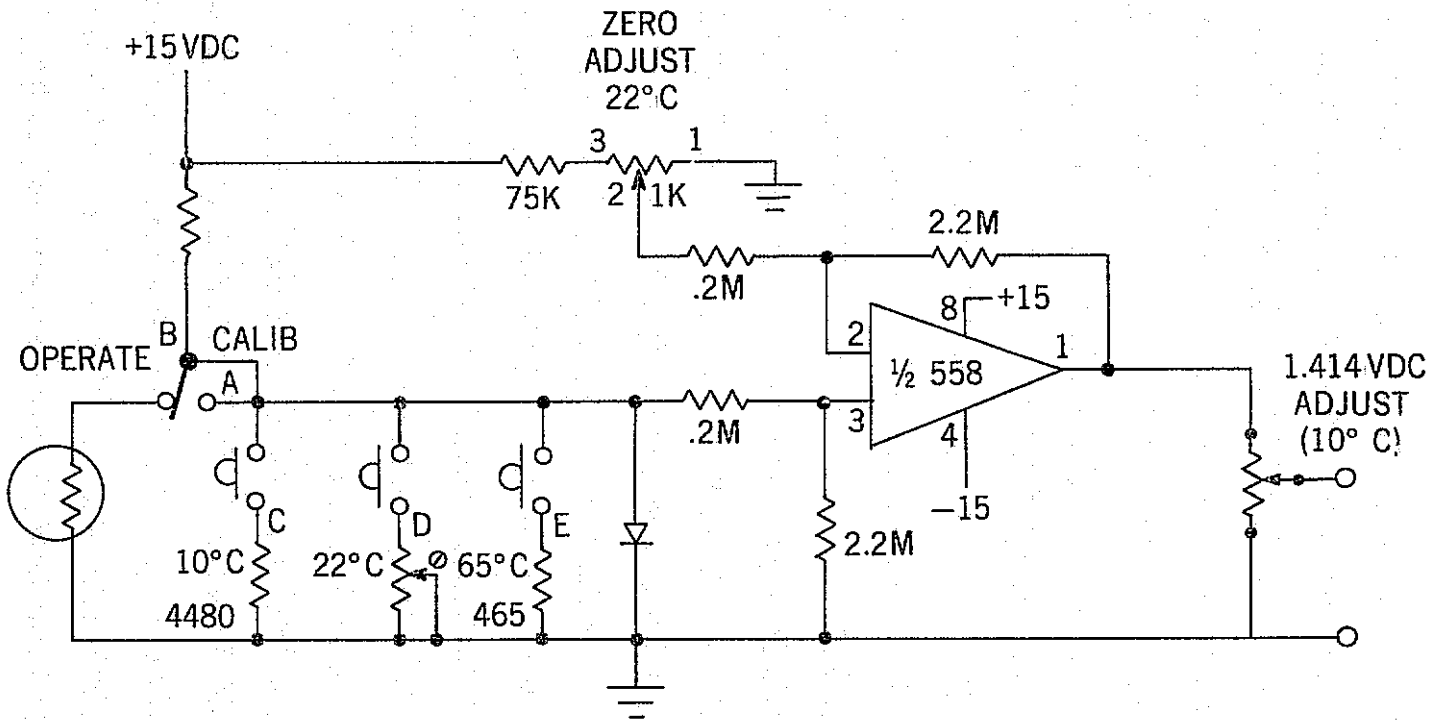

FIGURE 2 - TEMPERATURE SIGNAL CONDITIONING

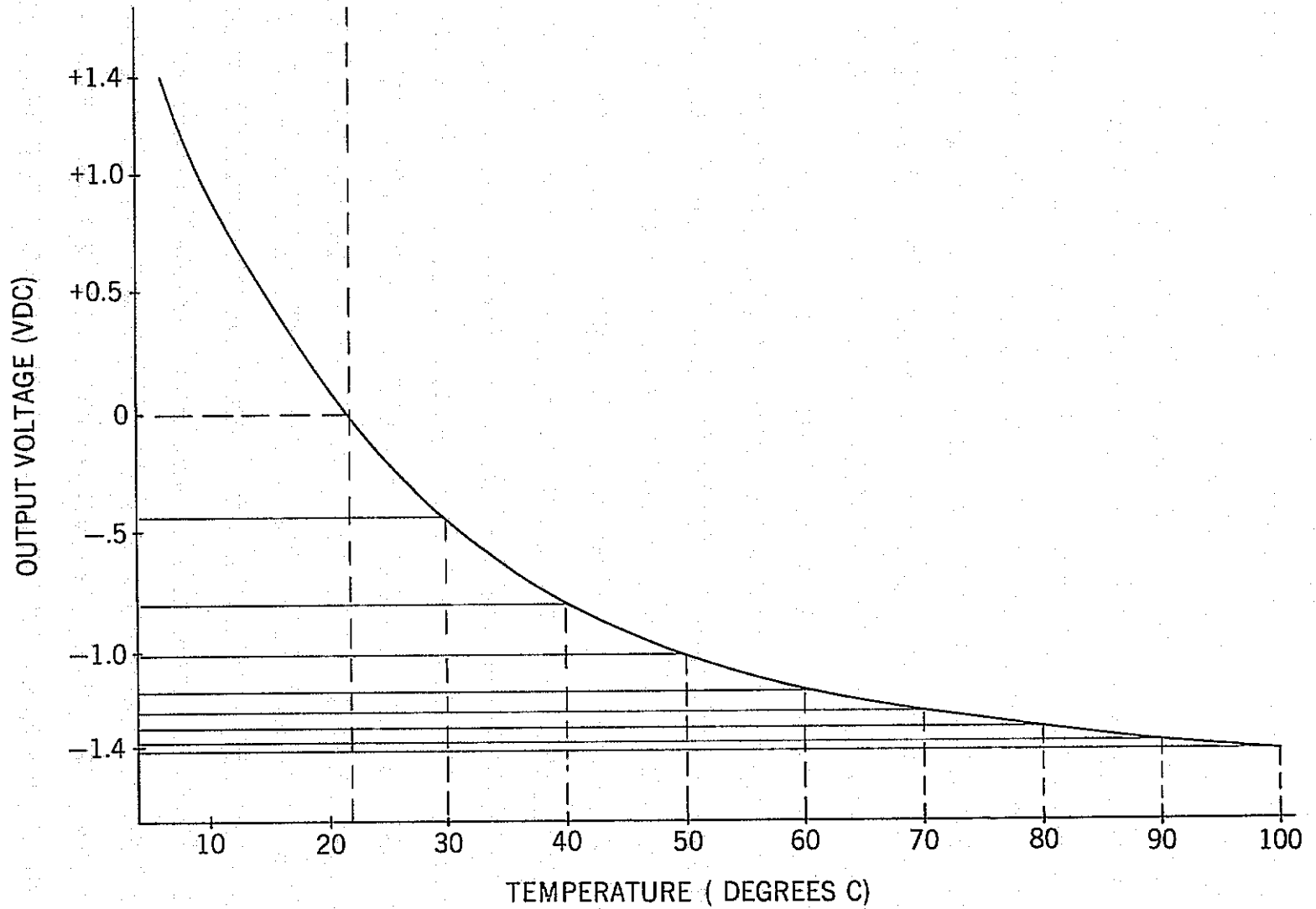

FIGURE 3 - THERMISTOR CALIBRATION
EXPANDED SCALE

ELECTRODES

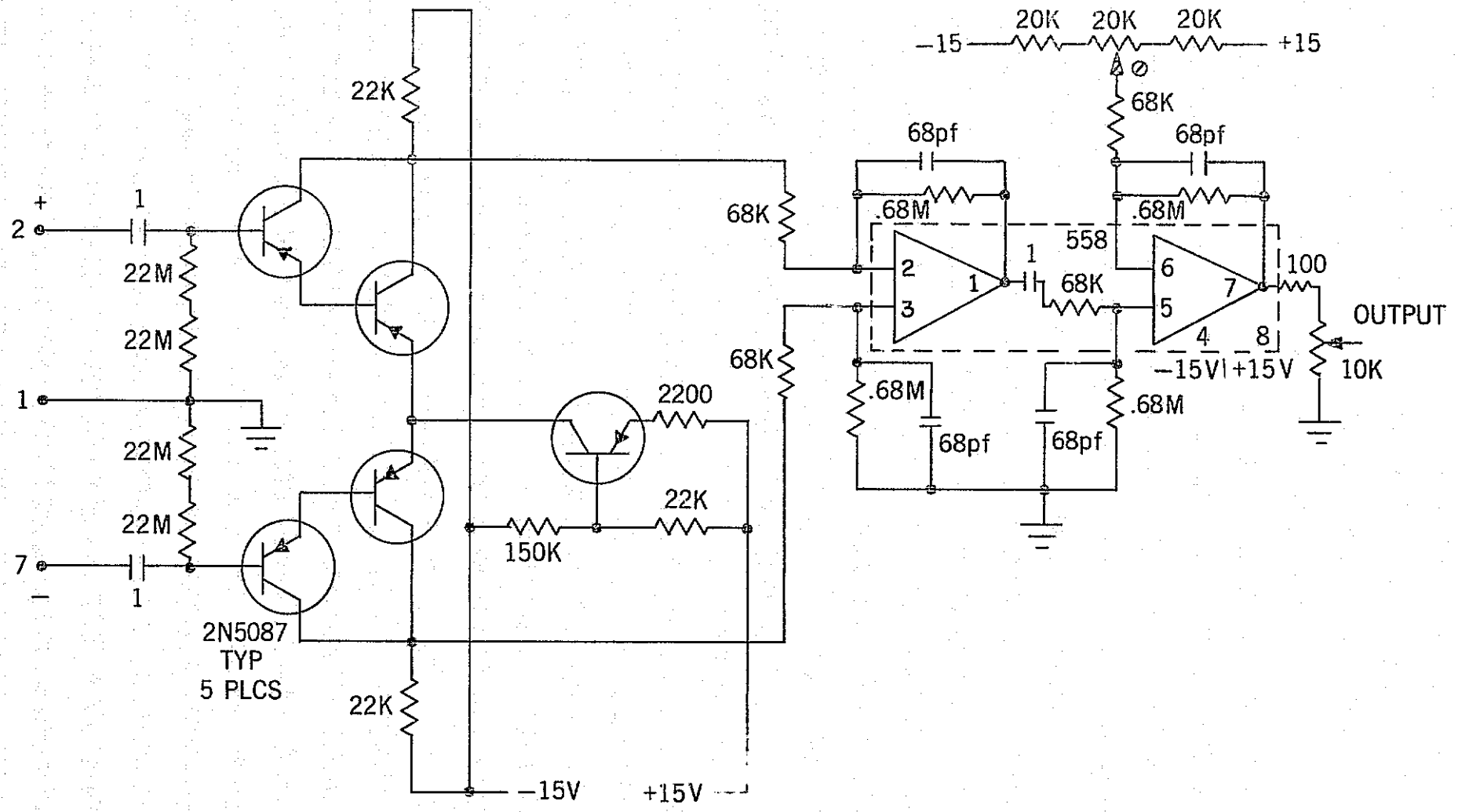

FIGURE 4 - ECG SIGNAL CONDITIONING

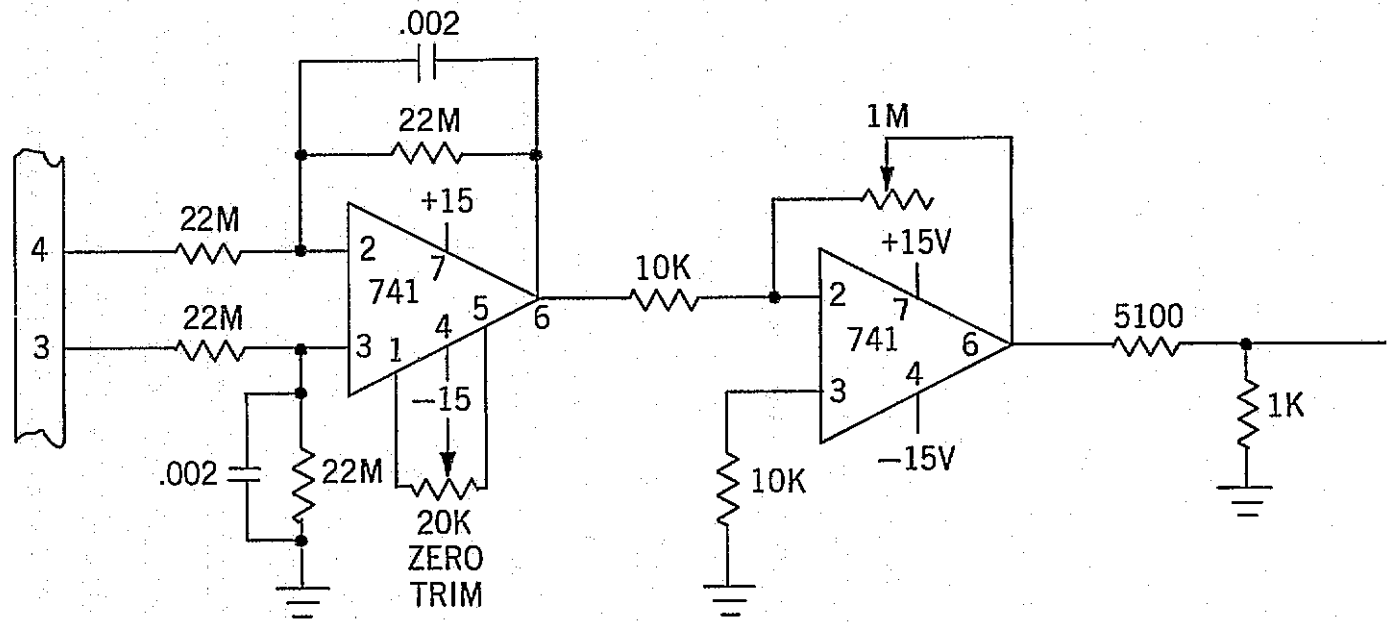

FIGURE 5 - RESPIRATION SIGNAL CONDITIONING

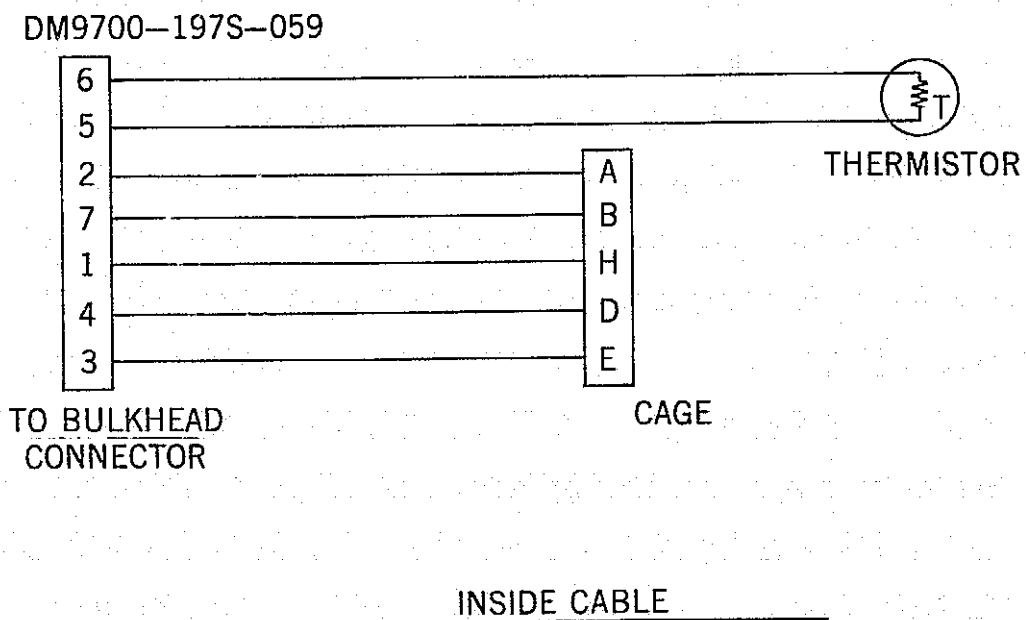
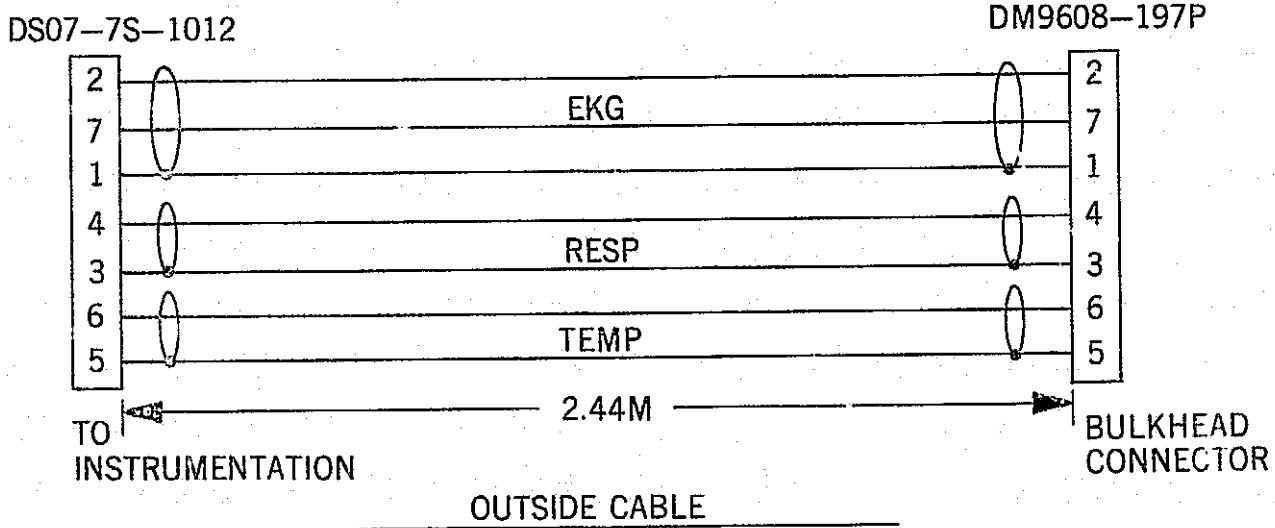

FIGURE 6 - CABLE SCHEMATICS

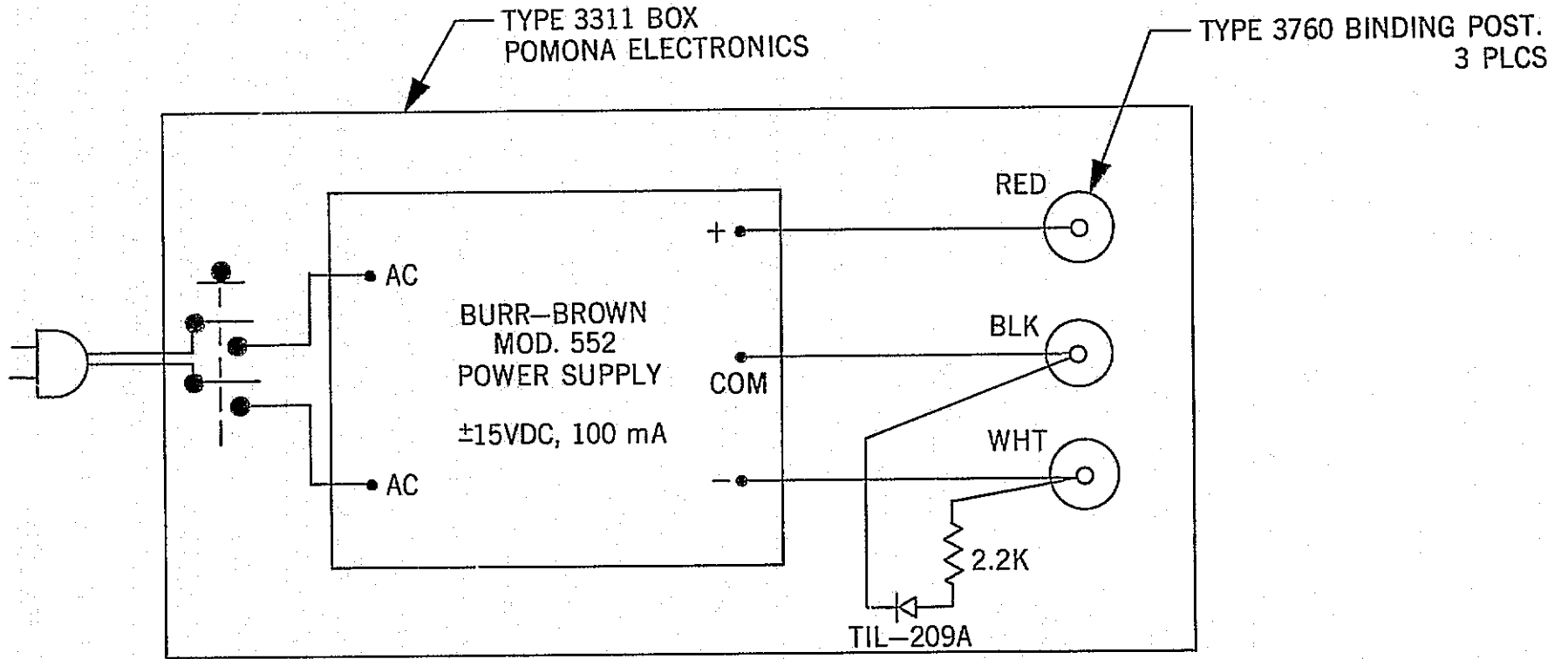

FIGURE 7 - ± 15 VOLT POWER SUPPLY

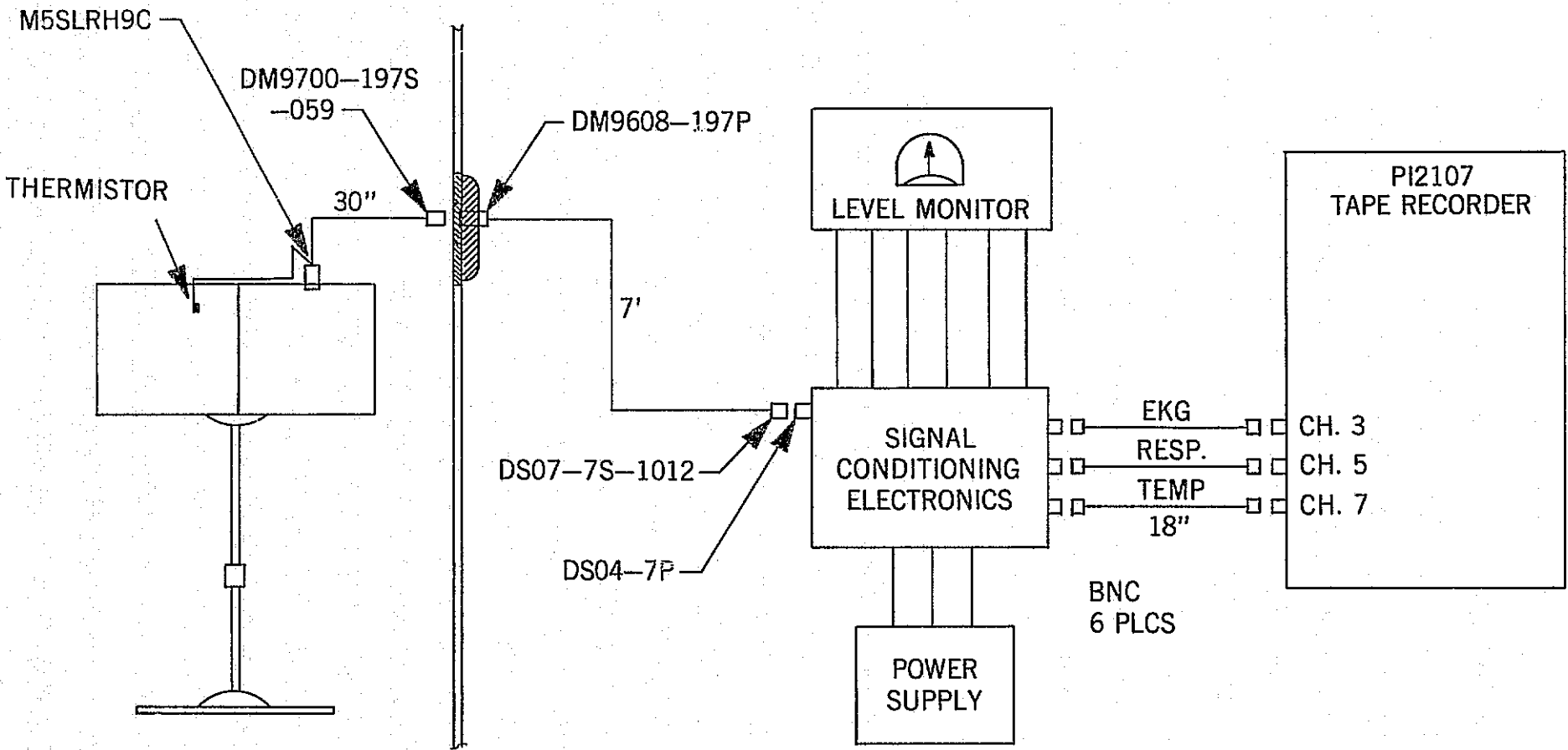

FIGURE 8 SYSTEM CIRCUITRY

SPECIAL REPORT
ON
THE BOEING TEST
ON
11 JUNE 1975

CONTRACT NO. NAS2-8668
ANIMAL EXPOSURE DURING BURN TESTS

CORRELATION OF THE PHYSIOLOGICAL
DATA WITH THE GAS ANALYSIS DATA

REPORT DATE: 5 AUGUST 1975

Prepared by:

James G. Gaume, M.D.

James G. Gaume, M.D.
Principal Investigator

Observations

1. There was no appreciable reduction of O_2 (20.+) in the enclosure by the time of death (TOD) at 18 minutes.
2. There was no significant increase in CO_2 (2.0%) in the enclosure by the time of death at 18 minutes.
3. There was no significant increase in CO (0.33%) in the enclosure by the time of death at 18 minutes. CO first appeared in the enclosure at approximately 10 minutes and reached approximately 3300 ppm (0.33%) by 18 minutes (TOD) giving approximately 8 minutes of exposure at low concentrations. This undoubtedly made a minor contribution to the hypoxia.
4. HCN had barely made its appearance in the enclosure by 18 minutes (TOD). Therefore, HCN appears not to have been a significant factor.
5. HF appeared in enclosure at 6 minutes, slowly increased linearly, to approximately 65 ppm by 13 minutes, then rapidly increased to approximately 325 by TOD (18 minutes).
6. HCl was barely detected until 12 minutes when it rose sharply to nearly 2000 ppm by TOD (18 minutes).
7. Enclosure temperature remained fairly constant at approximately $100^\circ F$ for 6 minutes, rose to $48.9^\circ C$ ($120^\circ F$) at 8 minutes, $60.^\circ C$ ($140^\circ F$) at 12 minutes and to $71.1^\circ - 73.8^\circ C$ ($160 - 165^\circ F$) at 18 minutes (TOD).

Discussion

Thus, three known factors appear to be the most significant in the death of the subjects.

1. Cage temperature increase to approximately $73.8^\circ C$ ($165^\circ F$) at 18 minutes (TOD).
2. Sudden increase in HCl concentration from near zero at 12 minutes to nearly 2000 ppm at 18 minutes (TOD).
3. Sudden increase in HF concentration from approximately 65 ppm at 12 minutes to approximately 350 ppm at 18 minutes (TOD).

It is very probable that these three factors exerted a synergistic effect to cause the expiration of subjects. The probable mechanism is most likely the onset of severe hypoxia, in spite of adequate O₂ present in the enclosure, produced by severe pulmonary edema and/or hemorrhage induced by the irritant and corrosive action of HCl and HF. High environmental temperature undoubtedly intensified the reactivity of HCl and HF. The possibility of other toxic gases which were not measured for, e.g., NO₂, SO₂, aldehydes, etc., should not be discounted. Also, the possibility of the "adrenalin effect" in the presence of halogenated hydrocarbons should be considered.

Conclusions

On the basis of the information available, and realizing that unknowns are involved, it can be tentatively concluded that the subjects expired from the combined hypoxic effects of primarily HCl, HF, and high temperature, with minor contributions to hypoxia being made by CO and possibly other unknown gases.