

NAS CR-134996
PWA-5302



**MODELING AND ANALYSIS
OF THE
TF30-P-3 COMPRESSOR SYSTEM
WITH INLET PRESSURE DISTORTION**

by

R. S. Mazzawy and G. A. Banks

**PRATT & WHITNEY AIRCRAFT
DIVISION OF UNITED TECHNOLOGIES CORPORATION**

April 1976

(NASA-CR-134996) MODELING AND ANALYSIS OF
THE TF30-P-3 COMPRESSOR SYSTEM WITH INLET
PRESSURE DISTORTION (Pratt and Whitney
Aircraft) 133 p HC \$6.00

CSC 21E

N76-21205

Unclas

G3/07

25216

prepared for

**NATIONAL AERONAUTICS AND SPACE ADMINISTRATION
NASA-Lewis Research Center
NAS3-18535**

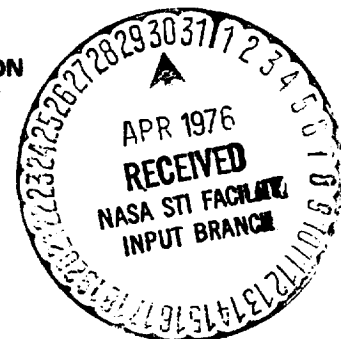

4
.
5

1. Report No. NASA CR-134996	2. Government Accession No.	3. Recipient's Catalog No.	
4. Title and Subtitle MODELING AND ANALYSIS OF THE TF30-P-3 COMPRESSOR SYSTEM WITH INLET PRESSURE DISTORTION		5. Report Date April 1976	
		6. Performing Organization Code	
7. Author(s) R. S. Mazzawy G. A. Banks		8. Performing Organization Report No. PWA-5302	
		10. Work Unit No.	
9. Performing Organization Name and Address PRATT & WHITNEY AIRCRAFT DIVISION UNITED TECHNOLOGIES CORPORATION EAST HARTFORD, CT 06108		11. Contract or Grant No. NAS3-18535	
		13. Type of Report and Period Covered Contractor Report	
12. Sponsoring Agency Name and Address National Aeronautics and Space Administration Washington, D. C. 20546		14. Sponsoring Agency Code	
		15. Supplementary Notes Project Manager, David G. Evans, Engine Research Branch, Air-Breathing Engine Division, NASA-Lewis Research Center, Cleveland, Ohio	
16. Abstract Circumferential inlet distortion testing of a TF30-P-3 afterburning turbofan engine was conducted at NASA-Lewis Research Center. Pratt & Whitney Aircraft has analyzed the data using its multiple segment parallel compressor model and classical parallel compressor theory. Distortion attenuation analysis resulted in a detailed flow field calculation with good agreement between multiple segment model predictions and the test data. Sensitivity of the engine stall line to circumferential inlet distortion was calculated on the basis of parallel compressor theory to be more severe than indicated by the data. However, the calculated stall site location was in agreement with high response instrumentation measurements.			
17. Key Words (Suggested by Author(s)) Turbofan Inlet Flow Distortion Compressor Stall Compressor Modeling		18. Distribution Statement Unclassified - Unlimited	
19. Security Classif. (of this report) Unclassified	20. Security Classif. (of this page) Unclassified	21. No. of Pages 134	22. Price*

* For sale by the National Technical Information Service, Springfield, Virginia 22151

FOREWORD

This report was prepared for the National Aeronautics and Space Administration, Lewis Research Center, under Contract NAS3-18535 to present the results of the analysis of circumferential inlet distortion data for the TF30-P-3 afterburning turbofan engine. Mr. D. G. Evans was the NASA Project Manager for this effort, assisted by Dr. A. Kurkov and Mr. W. M. Braithwaite, and Mr. R. S. Mazzawy was the P&WA Program Manager. This report was prepared by R. S. Mazzawy and G. A. Banks, with assistance from P. M. Dadd and other P&WA contributors.

TABLE OF CONTENTS

	Page
FOREWORD	ii
SUMMARY	1
INTRODUCTION	1
PROGRAM INPUT	2
LeRC Engine Data	2
P&WA Compressor Model and Rig Data	3
DATA ANALYSIS AND RESULTS	4
Uniform Inlet Data	4
Distortion Attenuation	6
Data Analysis	6
Multiple Segment Model Calculation	7
Crossflow Calculation	8
Program Output	9
Comparison of Predictions with Data	9
Distortion Sensitivity	12
Data Analysis	13
Parallel Compressor Predictions	17
SUMMARY OF RESULTS	19
REFERENCES	20
APPENDIX A – Circumferential Distortion Model	68
APPENDIX B – Program Output Symbols and Tabular Results	85

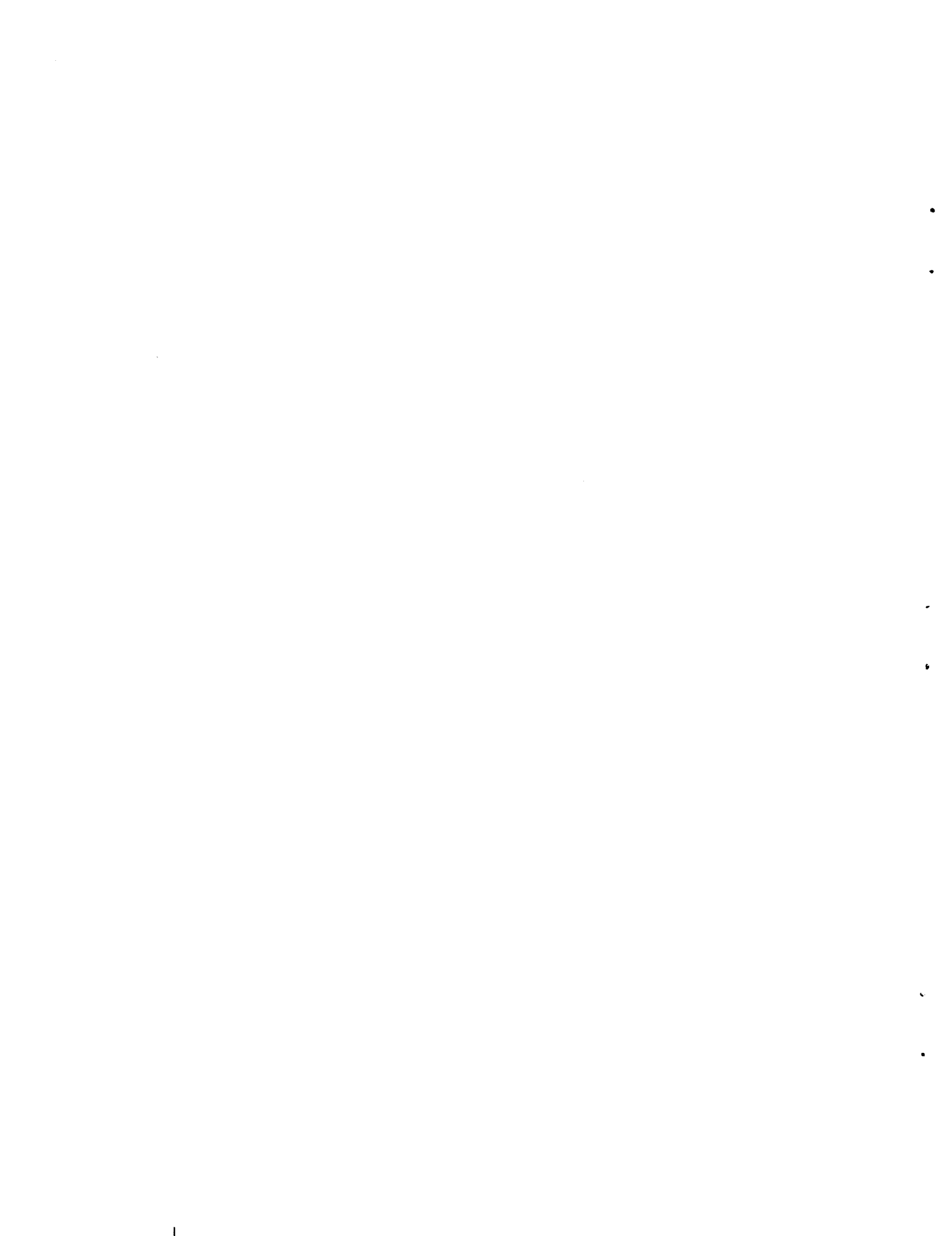

SUMMARY

The analysis of circumferential inlet flow distortion data taken by NASA-Lewis Research Center personnel from testing of a Pratt & Whitney Aircraft TF30-P-3 afterburning turbofan engine is presented herein. The distortion was generated by a NASA-developed air jet device which was capable of varying the amplitude, circumferential extent, and circumferential position of a low total pressure region. The data included detailed steady state instrumentation measurements for distortion levels below those required to stall the engine, as well as steady state and high response instrumentation measurements to document engine stall.

Data analysis was primarily performed through the use of the P&WA-developed multiple segment parallel compressor model. This model exists as a computer program and provides a detailed blade row by blade row definition of the distorted flow field for the TF30-P-3 compression system. The required pressure and temperature rise characteristics for each blade row were provided from previous P&WA compressor component rig testing. The results of this program were compared in detail with available pressure and temperature measurements at two low rotor speeds: 7400 rpm and 8600 rpm. Generally good agreement was obtained between the model calculations and the test data. The predicted attenuation and circumferential movement of the distorted region through the compressor were verified by the data. An analysis of the same data by NASA-LeRC personnel was presented in Reference 1 without the assistance of the model. Some of the conclusions reached in that data analysis are also included in this report for comparison purposes.

The engine stall data was analyzed on the basis of classical two-segment parallel compressor theory. A comparison is made between the distortion level which was observed to cause engine stall and the distortion level predicted by using parallel compressor theory. In general, the predicted level was lower than that which was measured experimentally. On the basis of the prediction, however, an estimate was made of the origin of the stall which was in reasonable agreement with the stall site determined from high response records. The data analyzed covered a low rotor speed range from 7300 rpm to 8700 rpm. It was determined in each case that stall was initiated in the front stages of the low pressure compressor.

INTRODUCTION

NASA Lewis Research Center (NASA LeRC) testing of the P&WA TF30 P-3 afterburning turbofan engine with circumferential total pressure distortion has provided detailed measurements of distortion attenuation and sensitivity. A description of the test may be found in Reference 1. These data have been analyzed by Pratt & Whitney Aircraft using its extensive background of experience with this engine and also using parallel compressor theory and the P&WA-developed multiple segment parallel compressor model. This model calculates a row by row prediction of distortion attenuation and provides an analytical basis for interpreting the engine measurements. A description of the model is presented in Appendix A.

The multiple segment model makes use of blade row performance (pressure and temperature rise) characteristics which have been derived from component rig testing with uniform inlet

conditions. For this reason, the undistorted inlet data for the NASA TF30-P-3 engine, supplemented by similar measurements made by P&WA on a number of TF30 engines, were analyzed to verify suitability of the model and provide a sound basis for interpreting the engine data with the non-uniform inlet pressure.

The circumferential distortion attenuation data were predicted and compared graphically with the measured data at two rotational speeds: 7400 and 8600 rpm (approximately 77 and 90 percent of low rotor design speed) at a Reynold's Number Index of 0.5. Flow velocity distortion predictions were also reproduced graphically. The circumferential variations of blade incidence and loading were also calculated and are included in a summary tabulation in Appendix B of this report.

Classical parallel compressor theory was used to predict the stall line sensitivity of the TF30-P-3 engine to circumferential pressure distortion. This calculation was based upon the same blade row characteristics used for the uniform inlet and distortion attenuation analysis. The distortion level was varied systematically until the amplitude necessary for stall was reached at the measured average engine operating point. The predicted level was compared to the observed level of distortion at stall for four rotational speeds: 7300, 7800, 8200 and 8700 rpm. The maximum loading as defined by diffusion factor was calculated for each blade row in order to fix the origin of compressor stall. High response instrumentation records for the NASA LeRC engine test were used to verify the initial stall location.

The work reported herein was done in the U. S. Customary system of units. The information in this report is provided in those units as well as the International System of Units (SI).

PROGRAM INPUT

NASA LeRC DATA

The Pratt & Whitney Aircraft TF30-P-3 turbofan engine was tested with 180° circumferential total pressure distortion in an altitude test chamber. An engine cross-section with the instrumentation station locations is shown in Figure 1. The distortion was generated by a NASA-developed air-jet device (Reference 2). This device produces total pressure distortion patterns through the injection of secondary air one diameter upstream of the engine directed against the primary inlet airflow. The distortion was rotated in 60° increments in order to effectively increase the instrumentation coverage and provide a better definition of the distortion pattern.

The data obtained by rotating the distortion pattern was reduced, analyzed and reported by NASA LeRC personnel in Reference 1. Two rotational speeds were tested: 7400 and 8600 rpm at approximately two-thirds the level of inlet distortion required to stall the

engine. Inlet distortion amplitude ($Pt_{\max} - Pt_{\min}/Pt_{\text{avg}}$) at stall was approximately 13 percent at 8600 rpm and 9 percent at 7400 rpm.

A subsequent test series using the same engine investigated the distortion sensitivity of the TF30-P-3 engine. These results were not included in Reference 1, but are related in Reference 3. During these tests the distortion amplitude was systematically increased at constant low rotor speed until an engine stall was recorded using high response instrumentation. The engine was then decelerated with the air-jet device setting held at the pre-surge position. The high pressure compressor 12th stage overboard bleeds were then held open and the engine was accelerated back to the pre-surge low rotor speed. Steady state instrumentation was recorded in order to document the distortion level and engine operating condition. This procedure was followed for a range of low rotor speeds from approximately 6700 rpm to 9000 rpm. Four low rotor speeds within this range have been selected for analysis under this contract. These are approximately 7300, 7800, 8200, and 8700 rpm.

P&WA RIG DATA AND COMPRESSOR MODEL

Pratt & Whitney Aircraft's TF30 compressor model is based upon individual static pressure and total temperature rise characteristics for each blade row. These non-linear characteristics are based upon mean diameter (defined as that diameter which separates the annulus into two equal flow areas) with the exception of the fan. The first three stages of the engine are separated into two regions representative of the flow which enters the fan duct and that which enters the engine core. The outer annulus is referred to herein as the fan, and the inner annulus, stations 2 to 2.3, as the first three stages of the low pressure compressor. These two regions are separated by a pseudo-boundary located at a diameter which is dependent upon the engine bypass ratio and fan geometry. These characteristics were derived from component rig testing of the TF30 compressors with uniform inlet conditions, by using measured static pressures and total temperatures. The necessary velocity triangles are determined by assuming that the exit angle for each blade row is constant in its own coordinate system. That is to say, the relative air angle is equal to the trailing edge metal angle minus a fixed deviation. This deviation is determined for each blade row at design incidence from two-dimensional cascade correlations. The inlet air angle relative to the following blade row is then calculated by using local mean values for axial velocity and wheel speed. The P&WA model additionally uses multiple circumferential segments and accounts for unsteady flow effects and circumferential crossflow which take place due to the distortion. Thirty-six segments have been used for the analysis of the TF30-P-3 distortion attenuation data.

This model is not capable of determining an engine operating point a priori since it has no simulations of any engine components except the compression system. Hence, necessary input requirements include total corrected airflow and engine bypass ratio, as well as high and low rotor speeds. The model may be exercised with either uniform flow conditions or with circumferentially non-uniform inlet total pressure and/or total temperature, and/or non-uniform exit static pressure. The operation of the model under non-uniform flow conditions may optionally be based upon classic parallel compressor theory or as the more complete multiple segment parallel compressor analysis.

DATA ANALYSIS AND RESULTS

UNIFORM INLET DATA

Uniform inlet data from NASA-LeRC tests were analyzed to verify the applicability of the P&WA blade row performance characteristics from TF30 compressor rig testing. The undistorted data analysis revealed that some measurements which are critical for the determination of engine bypass ratio were made with an insufficient number of instrumentation locations. In order to correct this deficiency the available data were supplemented by similar measurements made by P&WA on a number of TF30 engines. The complete data analysis during this phase verified that the blade row characteristics provided an adequate representation of the TF30 engine performance. An exception was the speed-airflow relationship for the fan, but this was corrected by modifying the characteristics to reflect slightly higher total airflow capacity for the engine tested at NASA LeRC relative to the component rig results.

The P&WA characteristics were derived from rig testing with different instrumentation and different Reynold's Number levels than were used in the NASA engine testing. The use of engine airflow for cooling purposes is another difference between the two tests. These differences resulted in real and apparent flow capacity shifts and were necessarily considered when the applicability of the characteristics was evaluated. The most convenient procedure for this task was to adjust the engine data for these differences and make comparisons with compressor rig overall performance maps. The engine core airflow calculation was an important part of this procedure and particular attention was given to using the most accurate technique available.

The TF30-P-3 turbofan is a mixed flow engine since the engine core and fan bypass flows mix together and exit through a common tailpipe and nozzle. This type of configuration precludes the separate measurement of engine and fan flows as is done in compressor rig testing. It is customary, therefore, to measure the total airflow and to calculate the engine bypass ratio (fan duct flow/engine flow) using other measured engine parameters. The calculation used for this purpose is based upon an energy balance between the compressors and turbines, the fuel and air flow entering and the flow leaving the engine. The equations as well as the measured and assumed parameters required for this calculation are outlined in Figure 2.

Initial calculations of engine bypass ratio for NASA LeRC uniform inlet data made on the basis of an energy balance between the compressors, burner, and turbines indicated unusual flow characteristics. Engine flow was calculated to increase as power setting was reduced in the intermediate operating range. It was initially suspected that the assumed primary burner efficiency used for this calculation was in error at reduced power. A thorough investigation revealed that the source of the problem was the use of only two turbine exit temperature rakes. It can be seen in Figure 3 that the right side and left side rake readings are significantly different in the intermediate speed range. An investigation of the distortion data showed a similar problem with the turbine exit temperature measurement over this range. The difference in temperature measurement is attributed to the change in circumferential swirl of the air through the turbine with rotor speed. As swirl changes with speed, the different rakes can be exposed to locally colder or hotter regions in the burner

exit profile which are not representative of true average conditions. For this reason, experimental engines tested at P&WA normally have six turbine exit temperature rakes to obtain accurate data. A comparison of the NASA LeRC data with other available engine data indicates that the left side rake measurement is closer to the actual temperature than the average of the two rakes. The left side temperature was therefore corrected to represent an average temperature using other engine experience. Bypass ratios were recalculated and the results were found to be more consistent with the other engine and compressor rig experience.

In summary, the following analysis has been conducted using the NASA LeRC uniform inlet data:

1. The engine bypass ratio has been calculated on the basis of an energy balance between the compressors, burner and turbines. Inconsistencies in turbine exit temperature measurements were caused by limited instrumentation coverage. These inconsistencies have been resolved on the basis of other TF30-P-3 engine data with more extensive instrumentation coverage.
2. Parasitic airflow (.67% for cooling purposes) is removed from the main airflow at station 3.0 (high pressure compressor inlet). This reduction in airflow was accounted for in determining high pressure compressor performance.
3. The large (for structural integrity) station 3.0 total pressure rakes cause a known back-pressure effect which raised the indicated total pressure measurement approximately 4% above the true level. The higher Pt 3.0 was accounted for to accurately determine the relative airflow matching and performance of the low pressure compressor and high pressure compressor. Small adjustments in total pressure level for differences in radial instrumentation between engine and rig tests were similarly accountable.
4. Different levels of Reynold's Number existed between the rig and engine tests. Flow capacity shifts due to these differences were applied for the fan, low pressure and high pressure compressors.

The resulting adjusted engine data has been plotted on the rig performance maps in Figures 4 through 6. The fan operating line, (Figure 4), falls below the normal sea level operating line because the NASA test was run with a choked exit nozzle, which has the same effect as running unchoked with a larger nozzle area. It is also observed that the NASA total corrected airflow is somewhat higher than that measured in the rig test. The difference, about 1.5%, can be attributed to engine-to-engine variation, and measurement error tolerances.

The low pressure compressor operating line is above the normal operating line, see Figure 5. This result is characteristic of the TF30 engine with a low fan operating line. Relative speed-flow differences at high speed are also expected because of the influence of the bypass ratio (which is relatively higher with the choked jet nozzle) on the low pressure compressor. The agreement of the data on the high pressure compressor map is quite good as shown on Figure 6.

Predictions of the engine data using P&WA's compressor characteristics are also shown on the figures. Fan predictions were based on compressor characteristics with the fan blade rows modified to reflect the 1.5% greater total corrected airflow measured by NASA. These predictions automatically include the effects of bypass ratio on the low pressure compressor map. The P&WA characteristics are seen to be quite adequate for use in predicting the NASA data for this contract. It should be noted that data were not available from the NASA LeRC engine test to substantiate the level of the rig-generated stall lines shown on the three maps. However, P&WA experience with TF30 engine and dual spool rig testing (Reference 6) supports the assumption that rig and engine stall lines are synonymous at the same Reynolds Number.

DISTORTION ATTENUATION

The circumferential distortion attenuation data analysis done under this contract is based upon the P&WA developed multiple segment parallel compressor model. This model provides a detailed prediction of the distorted flow field which is used for the purpose of interpreting the measured pressure and temperature distortion profiles at the different measurement planes within the engine. The data analysis of Reference 1 was done without the aid of such a calculation. Accordingly, some of the conclusions drawn in that analysis are different than those reached in this present work. These differences will be commented on later in the data analysis section.

Data Analysis

The NASA LeRC TF30-P-3 turbofan tests were conducted to evaluate the response of this engine to circumferential inlet total pressure distortion. The air jet device used to produce the circumferential distortion is described in detail in NASA TMX-1946. Rotation of the distortion in 60° increments provided detailed definition of the distorted flow field. 180° extent distortion rotation data were obtained at two locations on the engine operating line: one at approximately 7400 rpm, the other at approximately 8600 rpm. The data were normalized by NASA LeRC for variations in inlet total pressure. Additionally, the P&WA data analysis consisted of:

1. averaging data over the six distortion positions,
2. calculating the compressor performance parameters,
3. executing the P&WA multiple segment parallel model compressor program with appropriate input from the distortion rotation data including inlet pressure profile,
4. comparing the compressor performance parameters from the P&WA compressor model predictions with those calculated from the test data and with P&WA compressor rig experience,
5. comparing the flow field profiles as measured and as predicted by the P&WA compressor model at the axial locations used by NASA LeRC to measure flow properties within the compression system.

After the data were averaged over the six rotations at the stations required to determine the performance characteristics for the components of the TF30 compression system, the bypass ratios were determined by using the turbine exit temperature calibration obtained from the clean inlet data in the energy balance equations. The resulting compressor performance parameters were then adjusted as were the uniform inlet data for differences in Reynolds Number, station 3.0 total pressure instrumentation, and internal parasitic flows, between the NASA LeRC engine test and the P&WA compressor rig test. Inlet pressure measurements were then used to determine suitable pressure profiles for input to the multiple segment parallel compressor computer program.

Multiple Segment Model Calculation

The necessary boundary conditions for the multiple segment parallel compressor calculation are the inlet total pressure and temperature distribution (P_t , T_t , vs. θ), the circumferential exit static pressure distribution (P_s/P_s avg. vs. θ), the total airflow, bypass ratio and the rotor speeds. The exit plane for the fan stream was considered to be station 2.6F where measurements indicated that the static pressure was uniform circumferentially. The core stream exit plane was nominally at station 4.0 where static pressure was similarly uniform. An alternate exit plane used was station 3.0. Here the static pressure was also uniform and computer time could be saved by using this exit plane to determine the low pressure compressor response. The predicted output (total pressure and temperature distribution) of the low pressure compressor could then be input to the high pressure compressor as a separate computer run. This procedure was generally followed since it avoided having to make calculations in the high pressure compressor when iteratively determining the low pressure compressor solution and vice-versa. This procedure was also expedient for reducing the engine airflow into the high pressure compressor consistent with the parasitic bleed air removed at station 3.0. In summary, then, the model input requirements include:

1. inlet total pressure at each segment (from profile),
2. inlet total temperature (flat profile input avg of rotations),
3. low rotor speed,
4. total inlet airflow,
5. bypass ratio,
5. high rotor speed,
7. high pressure compressor airflow (low pressure compressor flow minus parasitic flow),
8. locations at which circumferential cross flows are significant.
9. Exit static pressure profile (P/P_{avg}) if not uniform.

Crossflow Calculation

When a total pressure distortion is imposed on a compressor, the inlet distortion level, the exit static pressure boundary condition, and the overall pressure rise characteristics determine the resultant velocity distortion and the distortion attenuation. When two compressors are involved (dual spool engine), the resultant velocity distortion depends upon how the two spools are coupled aerodynamically. If the axial spacing between spools is small and no large crossflow cavities are at the common boundary, then the combined overall pressure rise characteristics will determine the inlet velocity distortion. That is to say the downstream compressor will have the same effect as additional stages on the rear of the upstream compressor. When the axial spacing is large or crossflow cavities exist, the two compressors operate independently and the downstream compressor has little or no effect on the inlet velocity distortion. The TF30 engine has large crossflow cavities at station 3.0 directly in front of the tenth rotor. Flow is redistributed circumferentially within these cavities so that the velocity distortion exiting the low pressure compressor is reduced as it enters the high pressure compressor. The problem is complicated somewhat by the extraction of parasitic airflow (for cooling purposes) at this same axial location.

The realization that the two compressors are de-coupled, however, makes a very straightforward solution possible. This decoupling implies that the low pressure compressor exit static pressure should be circumferentially uniform whether the high pressure compressor is present (as in an engine) or not present (as in a single spool compressor rig). Hence the low pressure compressor solution can be obtained independently and the resultant exit total pressure and temperature distortion can be input as the inlet boundary conditions to the high pressure compressor. The total mass flow entering the high pressure compressor is reduced below the low pressure compressor exit mass flow by the amount of the parasitic airflow rate. The difference between the calculated flow distributions for the low and high pressure compressors gives a direct calculation of the circumferential crossflow required to satisfy simultaneously the boundary conditions for both compressors.

It was not known at the start of the analysis how many of the external cavities contributed significantly to the circumferential crossflow. Therefore, the first calculations were made assuming that the most significant flow occurred at the boundary between the low pressure and high pressure compressors, station 3.0. An inspection of the TF30-P-3 engine cross-section, Figure 1, shows large cavities at this location. The uniformity of static pressure at this station is another indication of a significant circumferential flow behind the low pressure compressor. The results of the initial calculation were then compared with the data. Subsequent calculations included additional major crossflow cavities chosen on the basis of geometrical considerations. This process was continued until the solution was not significantly altered by including additional crossflow in the calculation. In total, the seven crossflow locations shown in Figure 7 were included in the final calculation. The largest external cavities, besides station 3.0, are located at the IG V, stator 3, stator 7, and stator 12. Another cavity, though somewhat smaller, is located at stator 5. The axial slot which connects the compressor flowpath to this cavity was relatively large, and it provided a good measure of the significance of performing crossflow calculations for additional small cavities. Crossflows at all of these locations were determined by using a general correlation of flow coefficients as described in Appendix A.

The circumferential flow distribution within these cavities was determined which satisfied a continuity balance between the cavity and the compressor flowpath. The comparison with data is made using this final calculation, but the initial results based upon crossflow only at station 3.0 are shown for comparison at selected axial locations.

Program Output

The results of the distortion model include a detailed blade row definition of flow properties, velocity triangles and diffusion factor, and these results are presented in tabular form in Appendix B. Results are presented both in U. S. Customary and S. I. units. A summary table of terminology and units is also presented in Appendix B. Thirty-six segments were used to define the circumferential flow field at the inlet and through the compressor. Each segment is identified by number and also by circumferential position at the inlet of each blade row. The average swirl of a segment is identified at each axial station as flow swirl. The average circumferential displacement or swirl of a fluid particle as it moves axially through the compressor is also provided in the tabulations, and is referred to as particle swirl.

Comparison of Predictions with Data

Overall Performance

Compressor performance parameters for the two distortion rotation tests are presented in Figures 8 through 10. These are compared to the multiple segment compressor model program predicted performance for the fan, low pressure compressor and high pressure compressor. As mentioned in the section covering the analysis of clean inlet, the existing fan characteristics in the model were adjusted to reflect the fan uniform inlet speed-flow characteristics of the engine tested by NASA. The agreement of the distortion rotation points is at the same level as the uniform inlet data. On the LPC at the 7400 rpm low rotor corrected speed point, the model predicts a lower pressure ratio than that measured from the engine; at 8600 the model predicted pressure ratio was 3.5% lower than measured. The agreement is good if allowances are made for measurement accuracy. Agreement on the HPC is excellent.

Attenuation Prediction

The attenuation of the total pressure distortion by the TF30 compression system has been predicted for two different rotor speeds (7400 and 8600 rpm). Plots of total and static pressure and total temperature distortions have been compared at the instrumentation locations. The flow velocity predictions were also plotted at these locations but no comparison has been made with experimental results because there was no direct velocity measurement, and the measured data do not provide necessary circumferential detail to make an accurate velocity calculation. In addition, the prediction of the inlet flow angle at the IGV leading edge is presented but no data are available for comparison.

The predictions at 8600 rpm are shown in Figures 11 through 22. Figure 11 presents the inlet total and static pressure and total temperature distortions. The total quantities are input for the multiple segment model while the static pressure is calculated from the calculated velocity

distribution. It appears that the measured static pressure distortion is approximately two thirds of the prediction, but an inspection reveals that the static pressure instrumentation was located six inches upstream of the inlet guide vane leading edge. There is an exponential decay of the static pressure distortion upstream of the engine (Reference 7) as shown in Figure 12. The location of the engine instrumentation indicates that the distortion level measured at the station 2.0 instrumentation plane will be 64% of the distortion level at the IGV. This is verified by NASA LeRC data taken during another TF30 inlet distortion test program. The model prediction is for the IGV leading edge and is in good agreement with the data when the upstream attenuation is taken into account. The predicted variation in inlet air angle is shown in Figure 13. While no data exist with which to compare the prediction, the correct velocity distortion (as shown by the static pressure prediction) calculation implies an accurate air angle distribution. Further substantiation can be obtained from a comparison of measured and predicted inlet air angles, see Figure 14, for a NASA fan stage by using the same analysis (Reference 5). The fan attenuation results are displayed on Figure 15. Here it is shown that total pressure and temperature predictions are in very good agreement with the experimental measurements. The static pressure data exhibit a fair degree of scatter but are generally in agreement with the predicted results. The flow velocity prediction at this station is also included as seen on Figure 16.

Attention will now be directed to station 2.1 on Figure 17. The data and the prediction are in reasonably good agreement although the data are slightly more attenuated. The instrumentation locations do not permit verification of the predicted "bumps" in the total temperature distribution. The nearest temperature measurements do show a trend in the vicinity of the distortion edges which agrees with the prediction. In Reference 1, it was reported that a two-lobed velocity distortion pattern existed at station 2.1. No such patterns were predicted by the multiple segment analysis. An inspection of the static and total pressure distortions in the fan reveals that a precise definition of the distortion profiles, particularly near the edge of the total pressure distortion, is quite difficult to obtain solely on the basis of the measured data. The conclusion is that the two-lobe velocity pattern does not exist but is the result of insufficient data used in the velocity calculation.

At station 2.3 a comparison is presented between two different predictions and the experimental measurements. The first calculation (solid line) shown on Figure 18 was performed assuming that all crossflow occurred downstream of the low pressure compressor at station 3.0. The second calculation (open circles) incorporated the effect of circumferential crossflows in other major cavities as discussed previously. The inclusion of the additional crossflow resulted in greater attenuation of the total pressure distortion in the front stage with a resultant improvement in the agreement with the test data.

At station 2.6 there is a similar comparison made between the initial and final calculation in Figure 19. The trend towards increased attenuation can still be seen but is less pronounced between stations 2.3 and 2.6. The data show somewhat more pressure attenuation than is predicted by the model. The disagreement was difficult to understand because of the good agreement of the predicted temperature distortion with the data. The data which show the greatest disparity also indicate that the pressure is above the average value in the low pressure region and vice-versa.

An investigation revealed that the low rotor speed was somewhat low for two of the distortion rotation points (total pressure data shown at 60° and 120° and the two lower static pressure data points at approximately 40° and 100° as well as the single low static pressure data points at approximately 220° and 280°). The lower pressures resulting from the reduced speed cause an error in the calculation of the average pressure as well as in the indicated distortion. The fact that the speed measurably affected the pressures is supported by the three static pressure measurements which were only in disagreement when one or more of them were recorded at the lower speed. This same problem contributes to the data scatter which is visible at the other measurement stations.

Advancing to station 3.0 as depicted by figure 20, it can be seen that the total pressure distortion has been attenuated to the point where it is of the same order of magnitude as the data scatter. The prediction appears to be as good a fit through the data as can be made. The predicted temperature distortion becomes a better indicator of the model accuracy, and agreement is quite good. The temperature distortion has swirled approximately one quarter of a revolution at this point, a fact which has been accurately predicted by the analysis (note predicted particle swirl of 96.21° (at stator 9, Appendix B, pg. 122).

It was also observed in reference 1 that there was an amplification of total pressure distortion between stations 2.6 and 3.0 at the hub measurement diameter. Two possible explanations were offered: the hub pressure rise characteristics, or the station 3.0 crossflows. The multiple segment model predictions are based on mean diameter performance characteristics and did not predict any amplification. The hub performance characteristics are more likely to produce amplification and do provide a plausible explanation. The station 3.0 crossflows do increase the velocity distortion upstream of that axial location and would normally produce more attenuation of the distortion. However, a positive-sloped pressure rise - airflow characteristic would result in more amplification. Therefore, it is likely that both of these effects contribute to the observed data.

At station 3.12, solutions are once again compared with different assumptions on the circumferential crossflow. The difference in the two solutions is quite small at this station as seen in Figure 21. As at station 3.0, the pressure distortion is on the same order of magnitude of the data scatter. Although a small discrepancy appears to occur near the boundary between the high and low temperature region, the temperature distortion prediction is in good agreement with the test data.

Reference 1 reports two zones of static pressure distortion at station 3.12 and an inspection of Figure 21 does reveal them in the data. The two zones of pressure distortion were most likely due to the variation in engine rotor speed over the period of time required to rotate the distortion. The ranges of low compressor rotor speed were approximately 140 rpm for the 7400 rpm point and 30 rpm for the 8600 rpm point. These rotor speed variations, along with normal measurement error, result in pressure variations which are of the same order of magnitude as the pressure distortions in the high pressure compressor. Without the aid of the multiple segment model predictions it is extremely difficult to interpret the experimental results.

Finally, at station 4.0, see Figure 22, the same conclusion can be drawn concerning the amplitude of the pressure distortion and the data scatter. The agreement of the temperature dis-

tortion prediction and the experimental measurement is quite good. The large amount of circumferential swirl of the temperature distortion relative to the inlet pressure distortion location (nearly 160°) was accurately predicted by the multiple segment model (note predicted particle swirl of 161.86° in Appendix B). The engine core stream velocity distortion predictions at 8600 rpm are shown in Figure 23.

The results at 7400 rpm are presented in Figures 24 through 34, and are qualitatively the same as at 8600 rpm. The attenuation of the total pressure distortion is more gradual at the lower speed so that comparisons at stations 3.0 and 3.12 between data and predictions are more meaningful. In general, the model duplicates the test data quite well. The trends observed with the variation in circumferential crossflow at 8600 rpm are repeated at the lower rotor speed. The circumferential swirl of the distortion patterns is likewise well predicted at the various axial measurement stations in the engine.

A numerical calculation of the attenuation of the pressure distortion and the increase of the temperature distortion through the engine has been reported in reference 1. Some thought was given to a similar calculation using the model predictions; however, the distortions are not "square waves" at most axial positions, and thus any attenuation definition becomes somewhat subjective. Using the absolute maximum and minimum values of the calculated pressures, temperature and flow velocity, the distortion amplitudes at various axial locations can be approximately determined. This information is provided in Figures 35 through 38. The general conclusion to be drawn from these calculations is that the pressure attenuation occurs for the most part in the fan from stations 2.1F to 2.3F, and in the low pressure compressor from stations 2.3 to 3.0. Furthermore, the temperature distortion is created primarily in the fan. These conclusions are in general agreement with the data (Reference 1).

The average rotation or swirl of the low mass flow region through the compressor is predicted by the multiple segment distortion model as shown in Figure 39. The amount of swirl of a fluid particle is shown in Figure 40. These two "paths" are described in more detail in Appendix A and are approximately comparable to those followed by the pressure and temperature distortion respectively. The term "approximately" is used because while the low pressure and low flow region are generally coincident, the pressure can be modified by unsteady flow effects. These effects are dominant near the edges of the distorted region and can result in apparent shifts of the distorted region. In general, however, the unsteady effects are of second order for a multi-stage high pressure ratio machine like the TF30. The temperature distortion "path" is influenced by the swirl of the low flow region and thus has a component in phase (actually, 180° out of phase) with the pressure distortion as predicted by parallel compressor theory. The particle swirl influence on the temperature change across the rotor, however, provides the dominant effect on the distorted temperature region. This is obvious from an inspection of the data and the multiple segment model prediction.

DISTORTION SENSITIVITY DATA

The distortion sensitivity data analysis is performed using classical parallel compressor theory (Reference 4). Predictions are made for the distortion amplitude required to cause a compressor stall, and these are compared with the observed level. The stalling stage group is determined from high response instrumentation records supplied by NASA

LeRC. Within the indicated stage group the individual blade row aerodynamic loading (as calculated by the model) is used to locate the stall site.

Data Analysis

Sensitivity of the stability limit of the engine to 180° circumferential inlet pressure distortion was evaluated by increasing the level of inlet distortion while maintaining a fixed level of low rotor speed until the engine stalled. High response pressure data was recorded to determine the stalling stage group. Following stall, the 12th stage bleed was opened and the engine was decelerated to idle speed. The engine was then reaccelerated to the low rotor speed being investigated, and steady data was taken with 12th stage bleeds open and with the distortion generator at the same setting at which stall occurred. This data required additional adjustments for the effect of 12th stage bleed valve position, and instrumentation coverage, as well as for Reynolds Number, station 3.0 pressure instrumentation configuration, and internal parasitic flows. The procedure used to calculate the engine compression system performance at stall was as follows:

1. Measurements were adjusted to represent the circumferential average by using factors, normalized for distortion magnitude, which were based on distortion position and the air-jet distortion rotation measurements.
2. Bypass ratio was calculated using the energy balance method.
3. Compressor performance parameters were calculated, including the effect of internal parasitic flows.
4. Adjustments were made to the compressor performance parameters for the 12th stage bleed valve position. Influence factors were obtained from a P&WA computer simulation of engine operation, 12th stage bleeds open and closed.
5. Station 3.0 pressure instrumentation and Reynolds Number corrections were made.

Fixed instrumentation will often give misleading circumferential average measurements when used with circumferential inlet distortion. Rotation of the distortion, in effect, multiplies the fixed number of instrumentation circumferential positions, to give better average measurements. Data from the distortion rotation points were used to generate correction factors (Table I) for use in calculating the distortion stall points.

TABLE I

CORRECTION FACTORS FOR SINGLE DISTORTION POSITION

$N1\sqrt{\theta_{T2}}$	7400	7400	8600	8600
DISTORTION POSITION (i)	$0^\circ - 180^\circ$	$180^\circ - 360^\circ$	$0 - 180^\circ$	$180^\circ - 360^\circ$
P_{T2} CORRECTION	- .0132	- .0828	- .0446	- .0309
$P_{T2.3F}$ CORRECTION	- .0376	- .0754	- .0160	- .0884
$P_{T3.0}$ CORRECTION	- .0913	- .1235	- .1001	- .1628
$T_{T3.0}$ CORRECTION	.9979	1.0025	.9989	1.0090
$T_{T7.0G}$ CORRECTION	.9950	1.0083	.9931	1.0071
$T_{T7.0F}$ CORRECTION	.9991	1.0022	.9977	.9986

$$\text{PRESSURE CORRECTION} = \frac{(\bar{P}_T - P_{Ti})/P_{Ti}}{\left(\frac{P_{T_{\max}} - P_{T_{\min}}}{P_{T_{\text{avg}}}} \right)_i}$$

$$\text{TEMPERATURE CORRECTION} = \bar{T}_T/T_{Ti}$$

CORRECTIONS NOT CALCULATED FOR $P_{T2.6F}$, AND $P_{T4.0}$ CONSIDERED TO BE FULLY ATTENUATED

- AVERAGE OF PROBES FOR ALL SCREEN POSITIONS AT INDICATED STATION
- i AVERAGE OF PROBES FOR SINGLE SCREEN POSITION AT INDICATED STATION

These factors scale the readings at a given distortion position and rotor speed to the average for the complete series of rotations. It was assumed that the difference between the fixed position reading and the full rotation average was proportional to the inlet distortion level. Also, the effect of speed on the scale factors was assumed to be linear, and based on the two distortion rotation speeds. The effect of 12th stage bleed valve position on compression system operating parameters was estimated, using a TF30-P-3 simulation program. The 12th stage bleed air is exhausted into the fan duct which tends to back pressure the fan slightly reducing the total inlet corrected flow. The effect on the high pressure compressor is to lower the operating line, increase the inlet flow capacity, and increase the rotor speed. The increased high rotor speed and high pressure compressor flow capacity result in a lower low pressure compressor operating line. The results of the calculations indicated that the only significant variation of compressor performance parameters with distortion were the LPC pressure ratio (2.5% lower) and HPC corrected rotor speed (1.6% higher). All other parameters were in agreement with uniform inlet data.

Approximately forty high response pressure measurements were recorded for analysis of the engine stalls to locate the stalling stages. Selected measurements are presented herein to support the conclusions of the analysis. It should be noted that for the cases at 7300, 7900 and 8200 rpm the inlet distortion (low total pressure) region was located between 0° and 180° at station 2.0. The distortion swirls somewhat circumferentially so that lowest velocity and highest blade incidence probably occur in the third quadrant (180° to 270°). It will be seen from the high response records that the initial stall activity originated in the third quadrant for these cases. For the 8700 rpm point, however, the distortion was located between 180° and 360° . Hence, all of the stall activity started in the first quadrant at this speed.

The stall site was identified by locating periodic and/or large pressure fluctuations in the data records. As indicated in Reference 6, the sign of these fluctuations provides evidence of the stall initiating stage group. Pressure increases are normally observed at measuring stations upstream of the stall, with pressure decreases occurring downstream. There may be some exceptions to this guideline due to radial variations in the stall region, but multiple measurement locations can normally be used to sort out these uncertainties. The conclusions presented herein are based upon observations supported by the majority of the instrumentation.

Record 330 (7300 rpm)

The initial instability detected was a rotating stall which occurred between stations 2.3 and 2.6. Evidence to support this conclusion comes from total pressure records at stations 2.3, 2.6 and 3.0, see Figures 41 and 42. First of all an increase in pressure is observed at station 2.3 ($\theta = 265^\circ$) at approximately .155 seconds, and also at station 2.3 ($\theta = 85^\circ$) at approximately .163 seconds. The time interval (.008 seconds) required to travel from 265° to 85° ($\frac{1}{2}$ revolution) converts to a rotational velocity of 3750 rpm which is equal to 51 percent of low spool rotor speed (7341 rpm), a typical rotating stall frequency. At station 2.6 ($\theta = 88^\circ$) a decrease in pressure is observed at approximately .163 seconds. The change in sign of the pressure change indicates that the stall initiated between these two stations. Looking further to station 3.0 ($\theta = 118^\circ$) there is observed a decrease in pressure at approximately .164 seconds which serves to further confirm the origin within the low pressure compressor and the rotating stall cell frequency.

Shortly thereafter at approximately .169 seconds, a surge occurs in the high pressure compressor. The surge originates between stations 3.0 and 3.12 as can be seen from total pressure records at these two stations. For example, an increase in pressure is seen at station 3.0 ($\theta = 262^\circ$) while a decrease in pressure is noted at station 3.12 ($\theta = 268^\circ$) at this time (.169 seconds). Subsequently the surge progresses to other axial and circumferential locations involving the entire compression system by approximately .175 seconds.

Record 331 (7900 rpm)

The initial instability for this speed is also rotating stall occurring between stations 2.3 and 2.6. Evidence of this can be seen in Figures 43 and 44, at station 2.3 ($\theta = 265^\circ$) at approximately .202 seconds and also ($\theta = 85^\circ$) at approximately .209 seconds. The increase in pressure signifies that the stall site is downstream of station 2.3. The variation in the time the stall cell is observed at different circumferential locations verifies that there is a rotating stall cell. An inspection of the data record at station 2.6 ($\theta = 69^\circ$) shows a decrease in pressure at approximately the same time a pressure increase is observed at station 2.3, thus locating the stall origin. A decrease in pressure at station 3.0 ($\theta = 118^\circ$) at .212 seconds further substantiates a low pressure compressor stall.

A large overpressure at stations 2.3 and 2.6 at approximately .215 and .22 seconds is due to a high pressure compressor surge. Note that the location at 2.3 ($\theta = 265^\circ$) picks up the surge first due to the circumferential position of the distortion. Records at station 3.0 ($\theta = 118^\circ$) and station 3.12 ($\theta = 69^\circ$) confirm that the surge started in the front stages of the high pressure compressor.

Record 336 (8200 rpm)

The initial instability within the compressor is observed at station 2.3 ($\theta = 265^\circ$) at about .242 seconds on Figure 45. Later, there can be seen a sharp decrease in the total pressure measurement at station 2.6 ($\theta = 88^\circ$) at approximately .249 seconds. At about the same time there is a sharp increase in static pressure at station 2.3 ($\theta = 111^\circ$) which indicates that the stall originated between stations 2.3 and 2.6. There is also a decrease in total pressure at station 3.0 ($\theta = 118^\circ$) at .252 seconds to substantiate the occurrence of a low pressure compressor stall. Shortly following the initial stall, there is a surge from the low pressure compressor in between stations 2.3 and 2.6 at approximately .250 seconds. The large decrease in station 3.0 total pressure ($\theta = 118^\circ$) at .255 seconds in Figure 46 indicates that the low pressure compressor surged. The increased pressure at station 2.3 ($\theta = 111^\circ$) and the reduction at station 2.6 ($\theta = 88^\circ$) further fix the location. There was also some evidence that pointed towards the final surge event occurring behind station 2.6 ($\theta = 69^\circ$ and $\theta = 88^\circ$) since these records show an increase in pressure. The initial instability, however, clearly occurred between stations 2.3 and 2.6.

Record 341 (8700 rpm)

This stall also originated within the low pressure compressor as can be seen from high response records at station 2.3, ($\theta = 111^\circ$) station 2.6, ($\theta = 88^\circ$) and station 3.0 ($\theta = 118^\circ$), Figures 47 and 48. The increase in pressure at station 2.3 at approximately .382 seconds coincides with pressure decreases at the other two stations. A second, larger stall cell is observed later at the same stations at approximately .392 seconds. Very little activity was observed on the opposite side of the engine during this period in the station 2.3 pressure, ($\theta = 265^\circ$). The stall cell apparently decayed after it rotated a significant circumferential distance beyond the distorted region at this high rotor speed point.

An overpressure is observed at about .395 seconds at all the aforementioned locations when the high pressure compressor surges. The decrease in pressure at this time at station 3.12 ($\theta = 82^\circ$) verifies that the surge originated in the front stages of the high pressure compressor.

For the three lower rotational speeds the inlet distortion was circumferentially located between 0° and 180° , while it was located between 180° and 360° for the highest rotational speed. There is approximately 20° to 30° of rotation (swirl) of the distorted region between the inlet and the station 2.3 to station 2.6 stage group. The stall cell is most likely to originate within the distorted region. Due to unsteady flow effects the highest incidence region is usually not reached immediately as the rotor enters the distorted region, but is somewhere near the point at which the rotor leaves the distortion. After a stall cell is formed, it will rotate out of the distorted region and be recorded by the high response instrumentation. For the lower speed, the stall cell was first observed at 265° which is just past the distortion into the undistorted region. At a later time it rotates past the instrumentation located at 90 - 100° , which is just into the distorted region. This effect was verified when the distortion position was reversed for the high speed stall because the stall was observed to originate in the 90 - 100° circumferential region. Another feature of the high speed stall was the dissipation of the stall cell before it completed $\frac{1}{2}$ revolution. This is probably because the static pressure rise characteristics are steeper at higher speeds so that the amplitude of the velocity distortion is reduced. Therefore, a smaller increase in velocity is required to unstall the flow at high speeds than at lower speed.

Parallel Compressor Predictions

Distortion sensitivity was predicted on the basis of classic parallel compressor theory for four low rotor speeds. A low rotor speed range of approximately 7300 rpm to 8700 rpm was included in the analysis of the experimental data. The criterion for stall was based upon the compressor stall lines observed for uniform inlet rig testing. This was necessary because engine stall line data with a uniform inlet was not available. There is a large amount of data to support the assumption that the engine and rig stall line data are identical for the TF30. These data include dual spool testing of the TF30 compression system under USAF Contract No. F33615-70-C-1549 and Arnold Engineering Development Center (AEDC) engine testing of a TF30-P-3 engine. Documentation of both of these results is contained in Reference 6. Similar unpublished engine data obtained for TF30 engines at Pratt & Whitney Aircraft support the same conclusion.

The procedure followed in this analysis was to determine the level of distortion required to stall the compression system at the engine operating point. The distortion level was systematically varied until the low total pressure region intersected the uniform inlet stall line for some component of the engine compression system. Since the NASA LeRC tests were conducted at a lower Reynolds Number index than was the P&WA rig testing, the critical distortion level determined from the rig stall line should be higher than the NASA test levels. In order to correct for this, an adjustment to the predicted levels was made on the basis of Figure 49. The curves in this figure were empirically derived from the TF30 engine testing by P&WA at different Reynolds Number indices, and relate the necessary distortion amplitude required to stall the engine. The stalling distortion levels determined by parallel compressor have been compared with the NASA data on Figure 50. The closest agreement is obtained at 8700 rpm but the theory falls well short of the data at lower rotor speeds. This trend with speed is most likely due to unsteady flow effects which are minimized at higher speeds where compressor performance characteristics are nearly vertical and velocity distortions are small. The LPC high speed pressure rise characteristics are closer to being vertical than the low speed characteristics, so the results are consistent with the predictions made by parallel compressor theory.

From analysis of pressure traces, it was determined that the low pressure compressor stall line was reached first and initiated the engine stall. This conclusion is supported by the operation of the LPC on the rig stall line for the distorted flow region as seen in Figure 52. The fan and high pressure compressor are seen to be away from their respective stall lines in Figures 51 and 53.

An investigation of diffusion factors was made in an attempt to estimate the origin of stall within the low pressure compressor. Diffusion factor is a measure of the relative aerodynamic loading of a cascade of airfoils and is defined by the following equation from Reference 8:

$$\text{Diffusion Factor} = (1 - V_2/V_1) + \frac{1}{2\delta} \frac{\Delta V_\theta}{V_1}$$

where V_2 = exit velocity

V_1 = inlet velocity

ΔV_θ = change in tangential component of velocity (exit minus inlet)

δ = cascade solidity

The diffusion factors were calculated for each blade row on the basis of meanline air angles and geometry. The diffusion factors for the low pressure region were compared to those calculated with a streamline analysis for the uniform inlet engine design point at a sea level (Mach number = 1.2) flight condition. A comparison of the two calculations has been made in Figure 54 in an attempt to locate the probable stall site. From the figure it is observed that diffusion factors are relatively high on rotor 3 and stator 3, (low speed only) rotor 5 and rotor 6. Rotor 3, however, is not located between stations 2.3 and 2.6 where all the initial instabilities were detected with the high response instrumentation.

On this basis, the best estimate for the stall site would be either S3, R5 or R6 at the lowest speed (7300 rpm) and R5 or R6 at the other speeds. Diffusion factors calculated for the high pressure compressor are not high as can be seen in Figure 55. The engine design point levels are again shown for comparison. The low-levels verify that the high pressure compressor did not initiate the stall. The high pressure compressor, however, will be additionally distorted by the rotating stall from the low pressure compressor. The additional loading which the rotating stall imposes on the high pressure compressor and which causes the final engine surge is not reflected in the parallel compressor calculation.

A comparison shows that the stall sites from the high response records and the diffusion factor analysis are in qualitative agreement. It is difficult to estimate the exact stall location because of the distribution of the high response instrumentation. Furthermore, the diffusion factor analysis is based upon a mean diameter calculation and does not reflect radial variations in blade loading. The significant point is that basic parallel compressor theory gives a reasonable prediction for the origin of stall for the TF30 engine. This was true despite the fact that the predicted distortion level required to stall the engine was in disagreement with the test data.

SUMMARY OF RESULTS

The data analyses performed on the basis of the multiple segment and classical parallel compressor model predictions for attenuation and sensitivity with 180° circumferential pressure distortion are summarized as follows:

1. The square wave inlet total pressure distortions result in non-square inlet velocity distortions. The primary reasons for this are the inlet air angle variation caused by circumferential flow redistribution upstream of the fan and unsteady flow effects.
2. Circumferential crossflow within the compression system resulted in increased attenuation in the front stages.
3. The low mass flow region moves circumferentially as it travels through the compression system by an amount equal to the swirl of the acoustic path. This amounts to approximately 10-20 degrees in the fan and 65 degrees in the core in the direction of rotor rotation. The static and total pressure distortion swirl about the same distance.
4. The total temperature distortion is primarily created by the attenuation within the front stages. The temperature distortion swirls approximately 35 degrees in the fan and 165 degrees in the core in the direction of rotor rotation. This is comparable to the circumferential displacement of a fluid particle as it passes through the TF30 compression system.
5. The static pressure uniformity at station 3.0 indicates that the low and high pressure compressors are decoupled by the crossflow cavities at station 3.0. The good prediction of the distortion attenuation with this station 3.0 boundary condition verifies the decoupling.

6. Over the speed range of 7300 to 8700 RPM, instability began as a rotating stall between the 3rd and 6th stages of the low pressure compressor. A compression system surge occurred shortly after the initial instability in each case.
7. The diffusion factors calculated by parallel compressor in the low pressure region were relatively high in the front low compressor stages. This circumstance is consistent with the observed origin of the initial instability.
8. The predicted distortion level for stall falls below the test level at all rotor speeds.

REFERENCES

1. "Effect of a 180° Extent Inlet Pressure Distortion on the Internal Flow Conditions of a TF30-P-3 Engine", C. E. DeBogdan, J. H. Dicus, D. G. Evans, R. H. Soeder, NASA TMX-3267, September 1975.
2. "Technique for Inducing Controlled Steady-State and Dynamic Inlet Pressure Disturbances for Jet Engine Tests", C. L. Meyer, J. E. McAulay, T. J. Biesiadny, NASA TMX-1946, 1970.
3. "Some Comparisons of the Flow Characteristics of a Turbofan Compressor System with and without Inlet Pressure Distortion", NASA-TMX-71574, D. G. Evans, C. E. DeBogdan, R. H. Soeder, E. J. Pleban, July 1974. (Project SQUID Workshop - "Unsteady Flows in Jet Engines", UARL-3-PU).
4. "Performance of Axial Compressors with Asymmetric Inlet Flows", R. Katz, 1958, Cal. Inst. Tech. Rep., AFOSR TR-58-89.
5. "Single Stage Evaluation of Highly Loaded, High Mach Number Compressor Stages II. Data and Performance, Multiple Circular Arc Rotor" by D. H. Sulam, M. J. Keenan and J. T. Flynn, NASA CR-72694.
6. "Compressor Stability Assessment Program", AFAPL-TR-74-107, Volume 1, Final Report by P&WA under USAF Contract F33615-70-C-1549, December 1974, pp. 197-208, 210.
7. "Attenuation of Circumferential Inlet Distortion in Multi-Stage Compressors" by G. Flourde and A. Stenning, Journal of Aircraft Vol. 5, No. 3, June 1968, pp. 236-242.
8. "Aerodynamic Design of Axial Flow Compressors, NASA SP-36, 1965.

REPRODUCIBILITY OF THE
ORIGINAL PAGE IS POOR

TF30

INSTRUMENTATION LOCATION

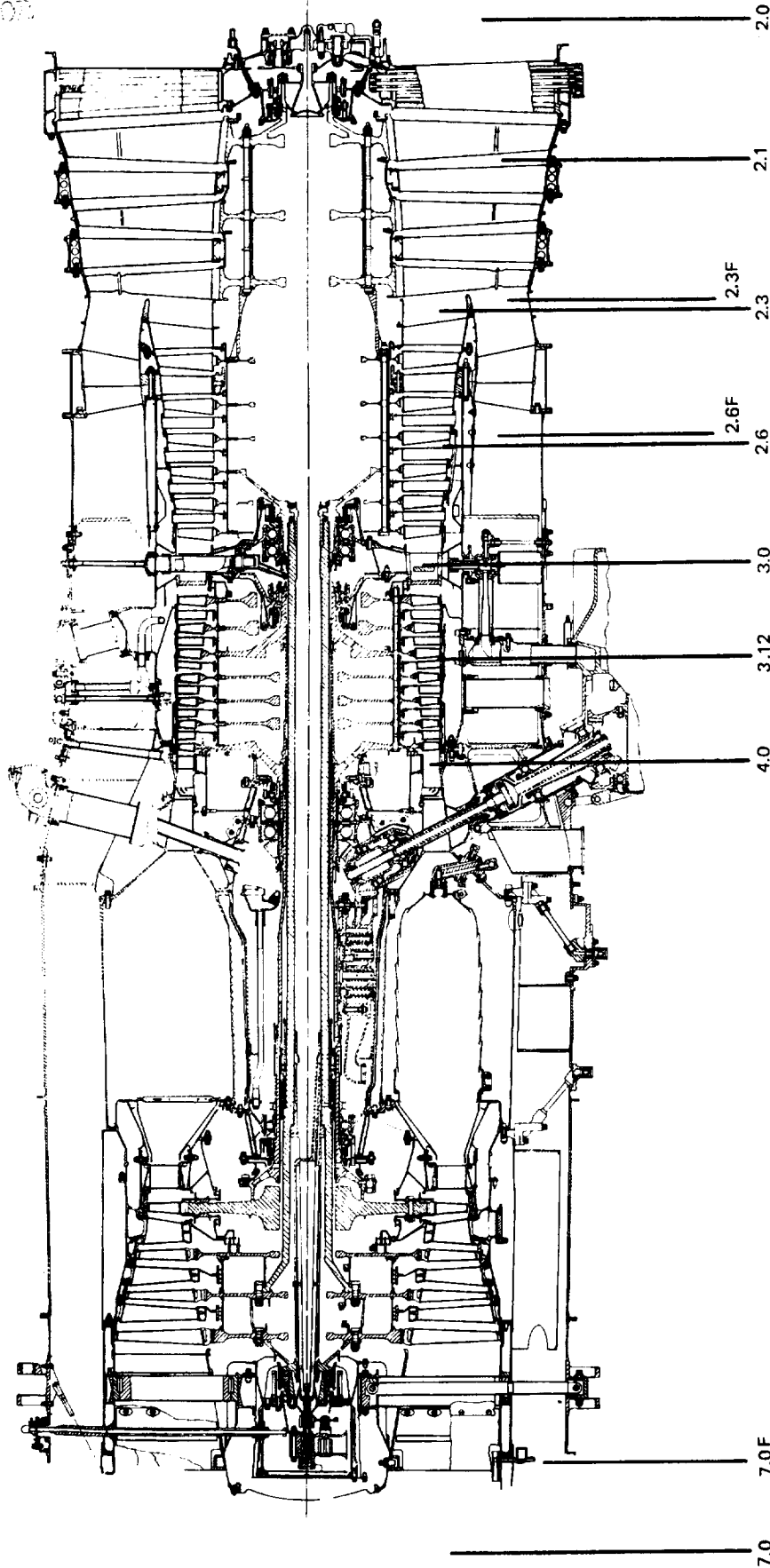
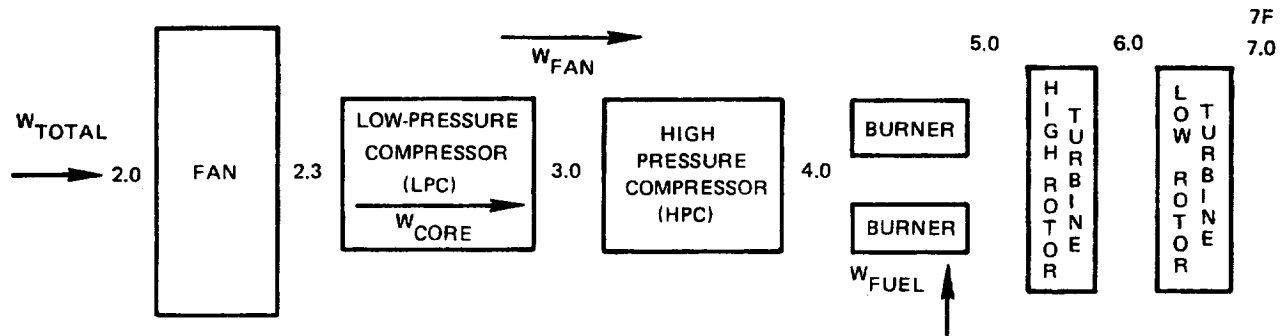

Figure 1 Engine Cross Section with Instrumentation Locations



W_{total} , W_{core} and W_{fan} are airflows through the components and W_{fuel} is fuel flow added in burner.

Energy Balance

- **Basic Equations:**

1. $W_{total} = W_{core} + W_{fan}$
2. $W_{core} (h_{T7.0} - h_{T2.0}) - W_{fuel} (h_v - h_{T7.0}) + W_{fan} (h_{T7F} - h_{T2.0}) = 0$

Where:

h_T = Total Enthalpy
 h_v = (Heating value of fuel) x (burner efficiency) + (enthalpy of liquid fuel)

- **Measured Parameters:**

1. Total airflow
2. Fuel flow
3. Inlet (2.0) and fan exit (7F) total temperature
4. Turbine exit (7.0) temperature

- **Assumptions:**

1. Burner efficiency (.99)

Figure 2 Engine Airflow Calculation Techniques

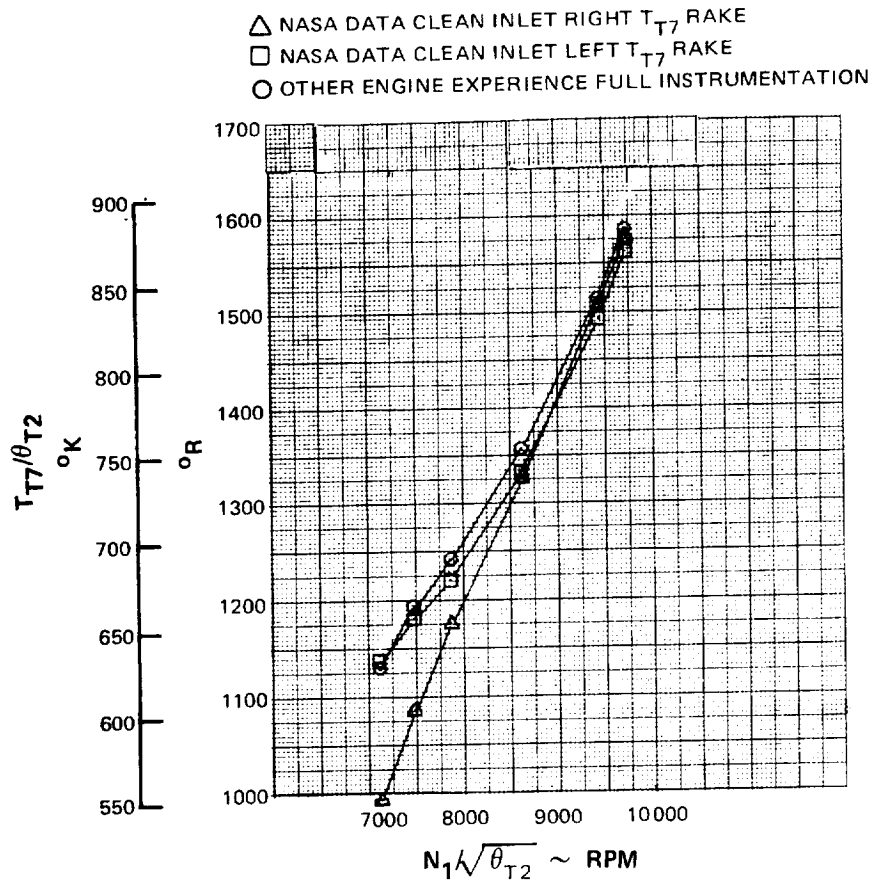

Figure 3 Comparison of NASA Turbine Exit Temperature Measurements with P&WA Experience

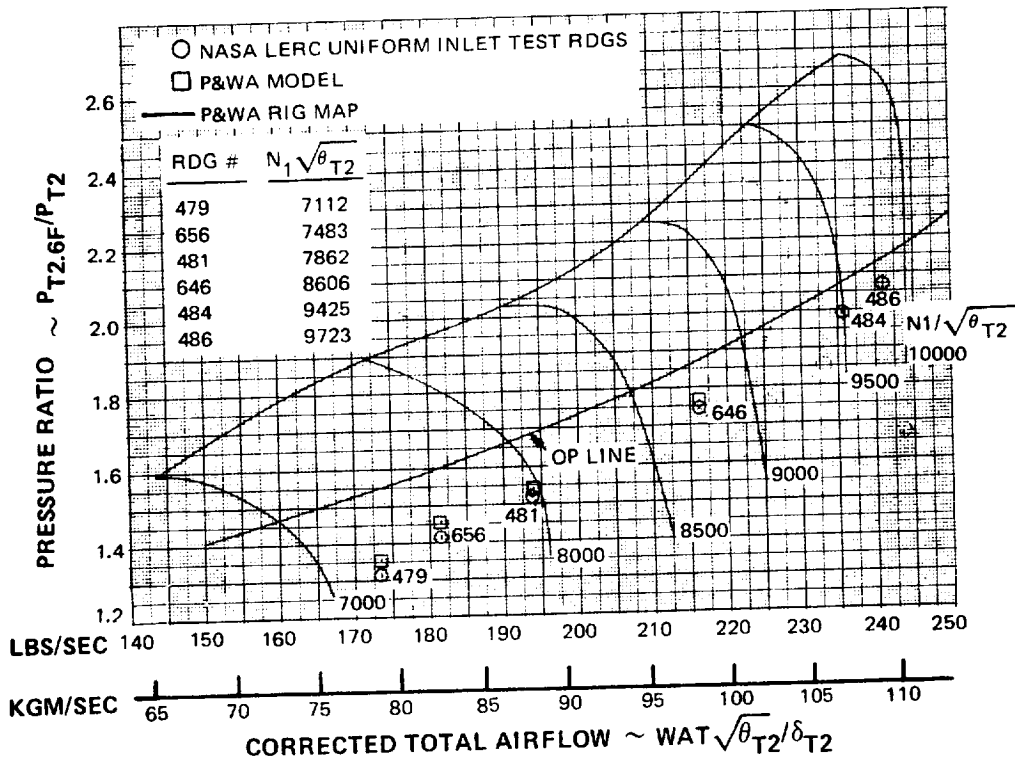

Figure 4 Comparison of Uniform Inlet Test Data with P&WA Multi-segment Model (Fan Performance Map)

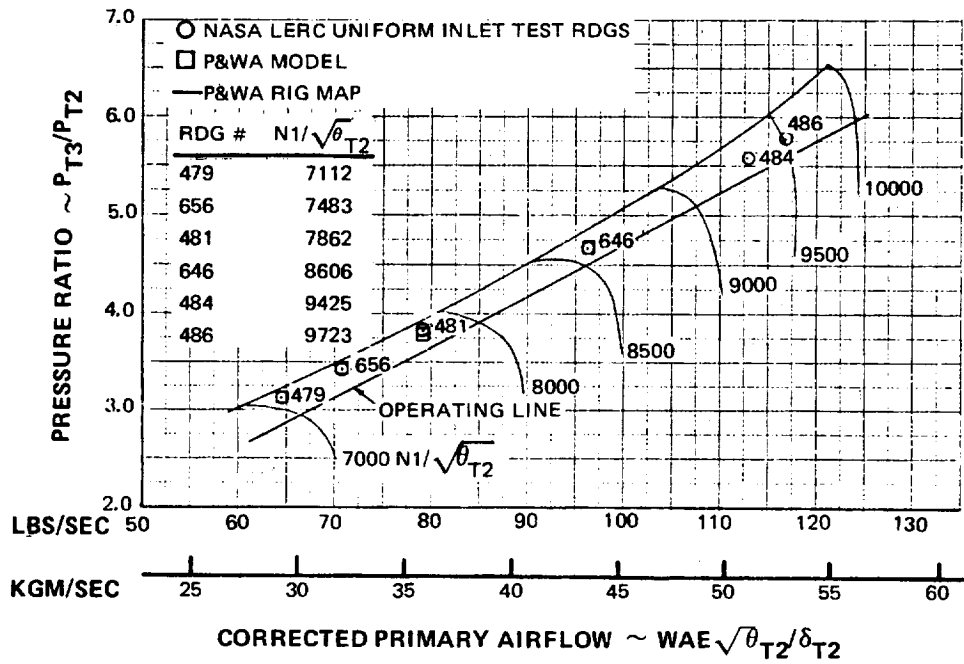

Figure 5 Comparison of Uniform Inlet Test Data with P&WA Multi-segment Model (LPC Performance Map)

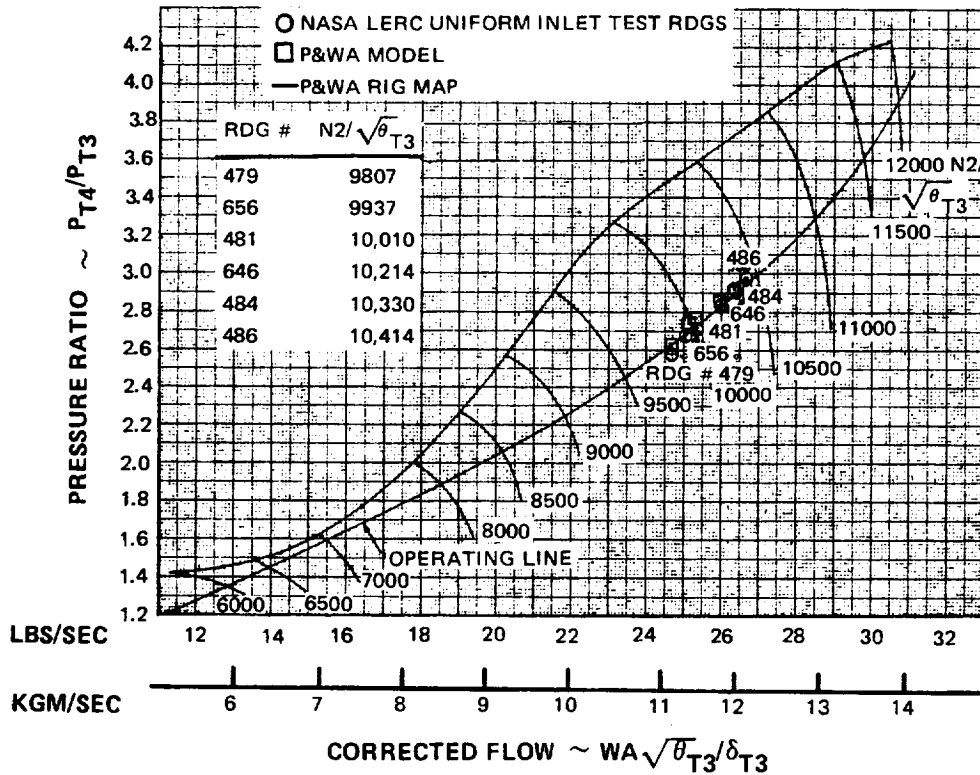

Figure 6 Comparison of Uniform Inlet Test Data with P&WA Multi-segment Model (HPC Performance Map)

TF30

CROSSFLOW CAVITY LOCATIONS

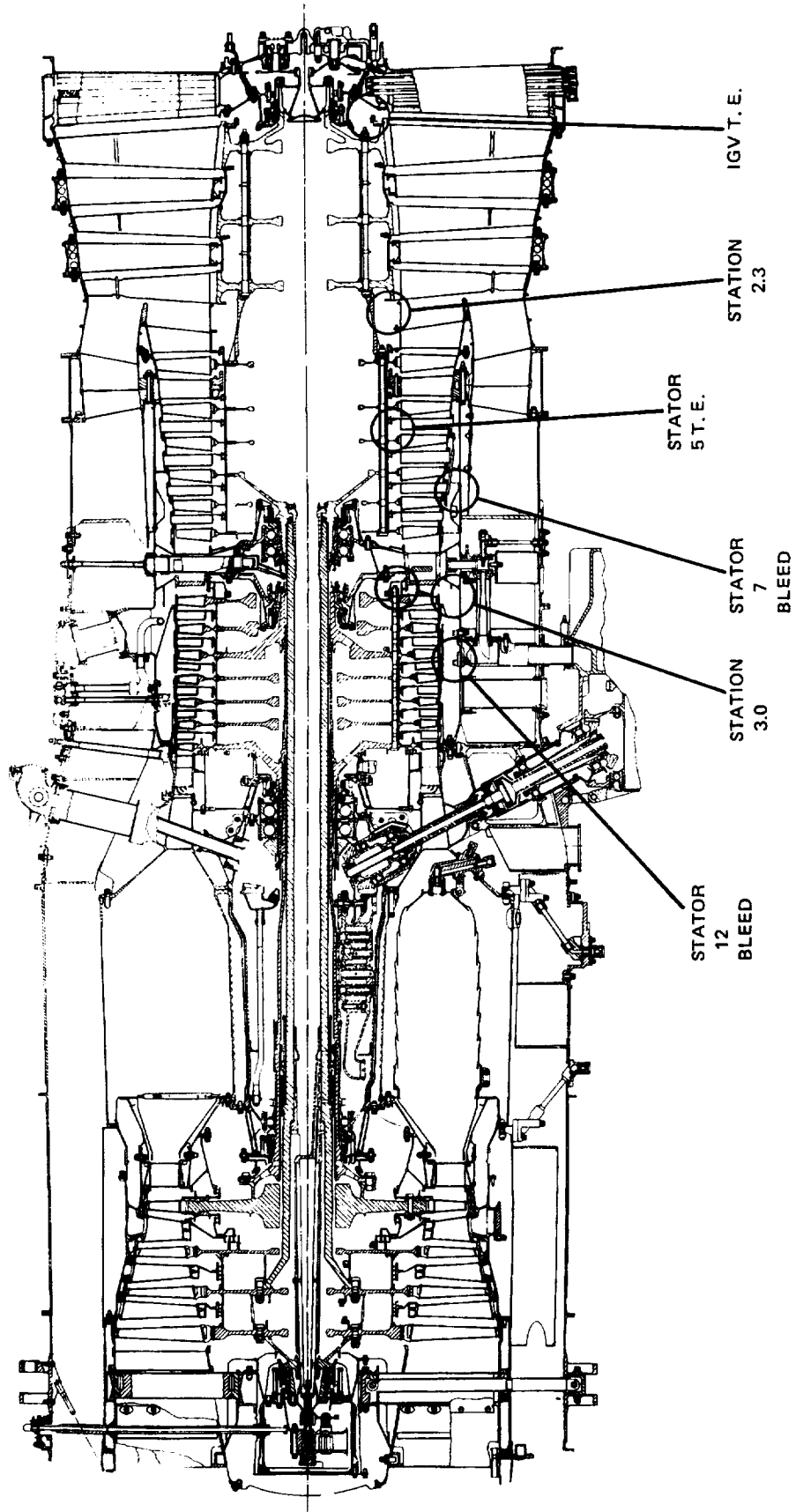

Figure 7 Engine Cross Section with Crossflow Cavity Locations

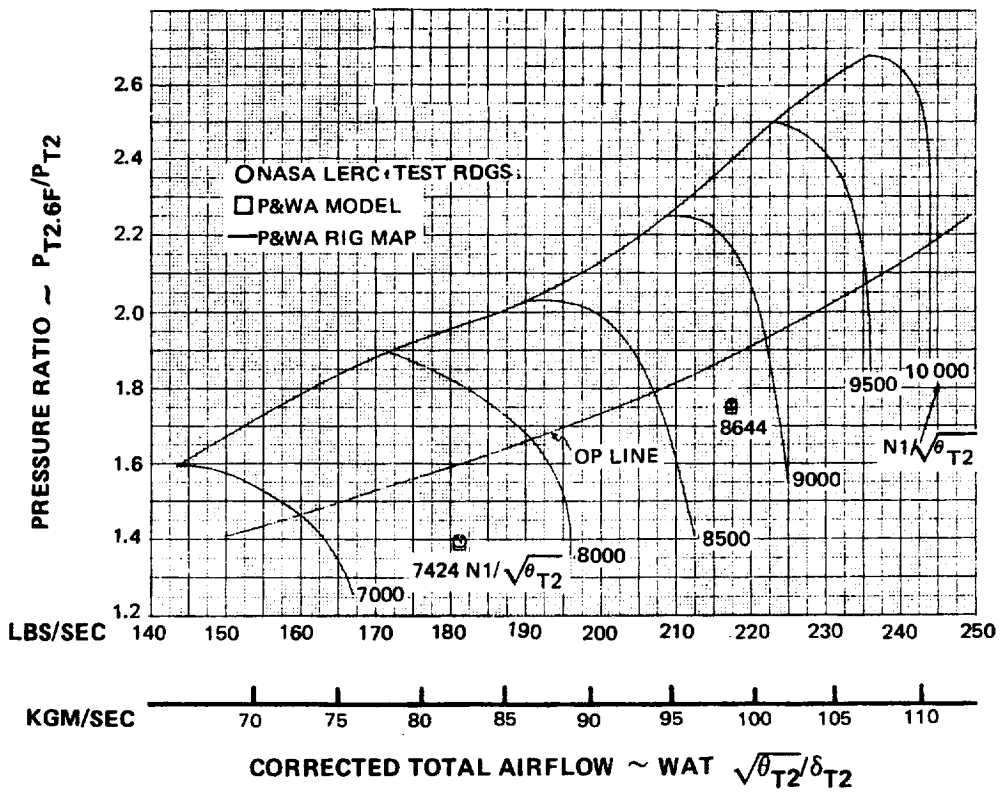

Figure 8 Comparison of Distortion Rotation Test Data with P&WA Multi-segment Model (Fan Performance Map)

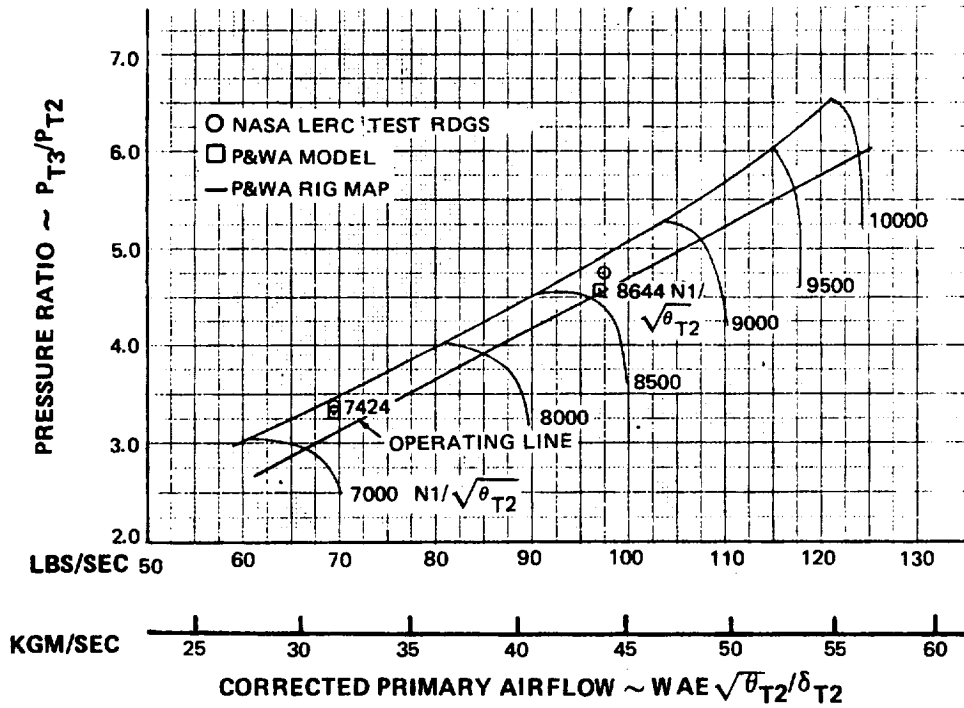

Figure 9 Comparison of Distortion Rotation Test Data with P&WA Multi-segment Model (LPC Performance Map)

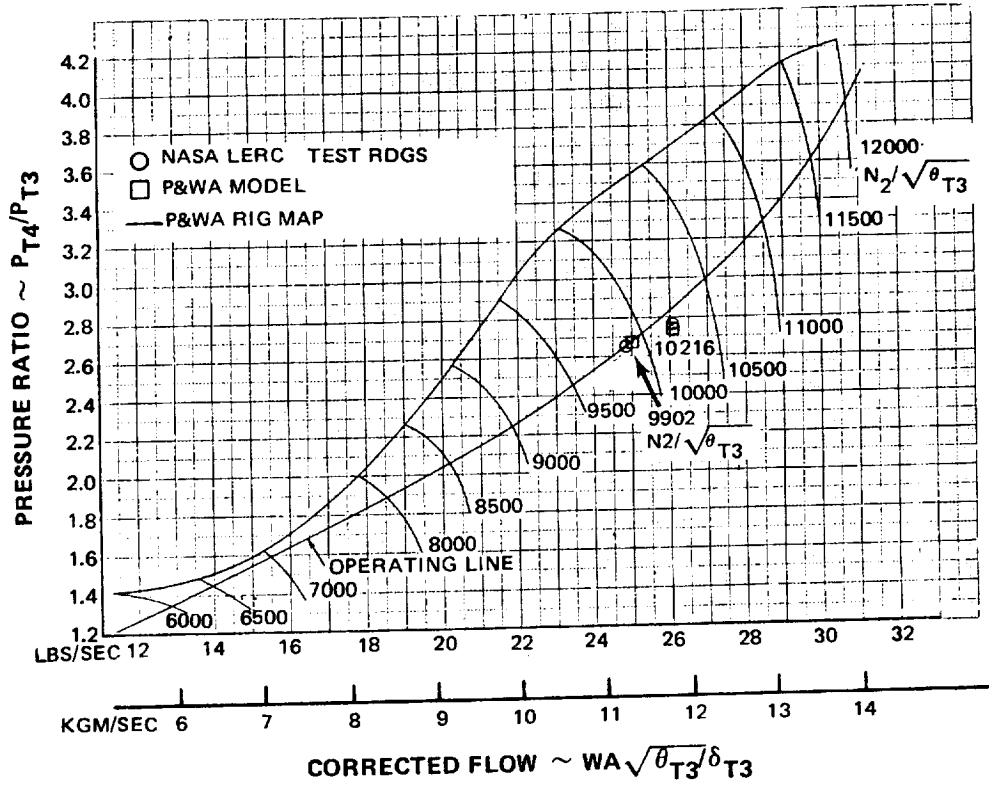

Figure 10 Comparison of Distortion Rotation Test Data with P&WA Multi-segment Model (HPC Performance Map)

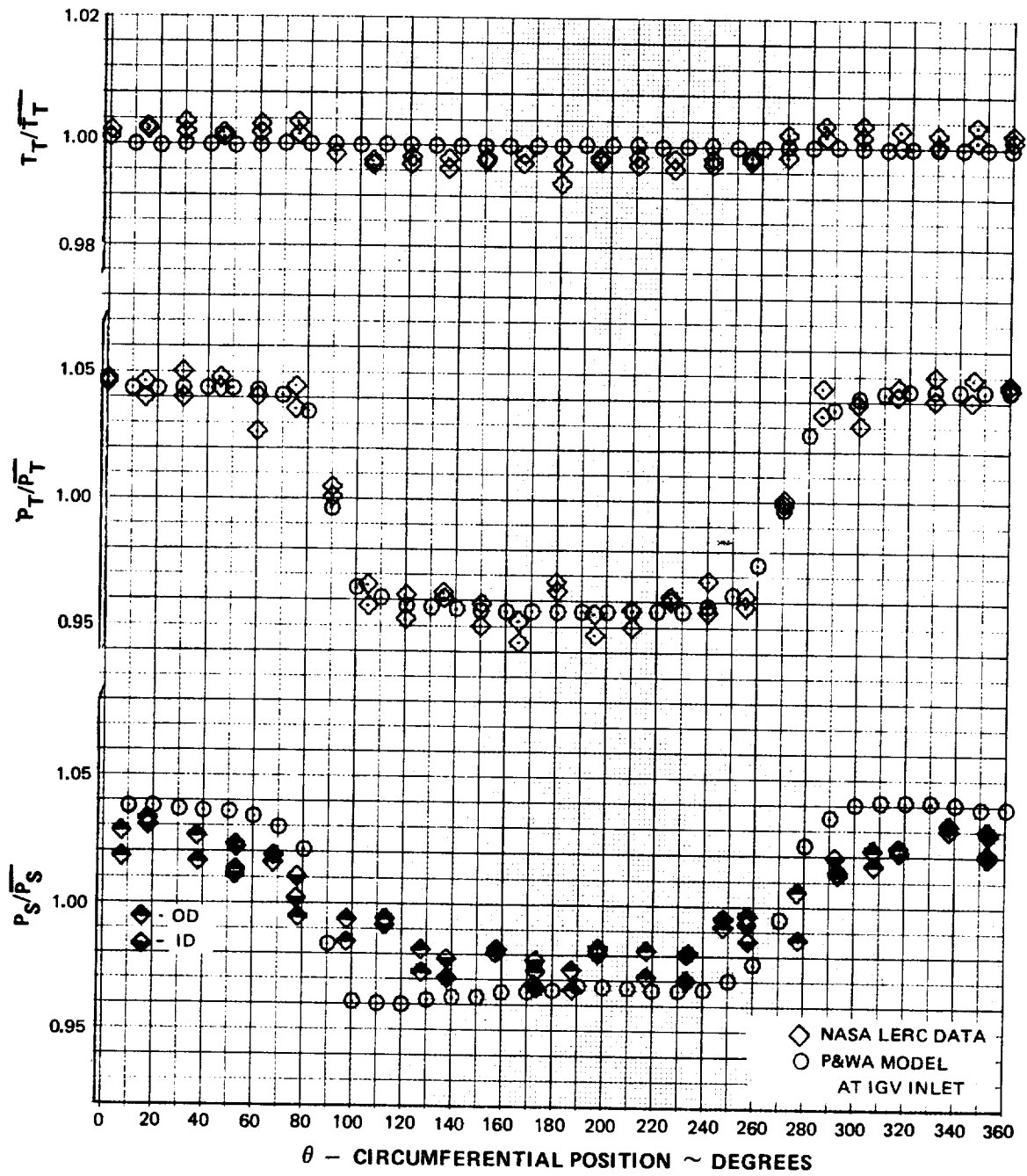

Figure 11 Circumferential Variation of Inlet Pressure and Temperature at 8600 rpm

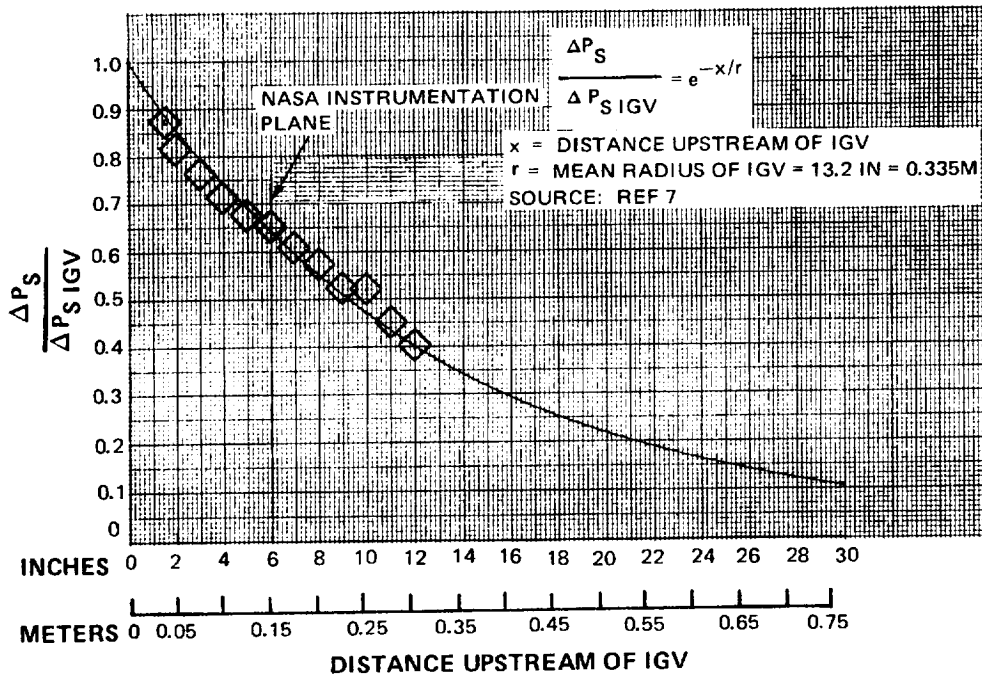

Figure 12 Upstream Attenuation of Pressure Distortion

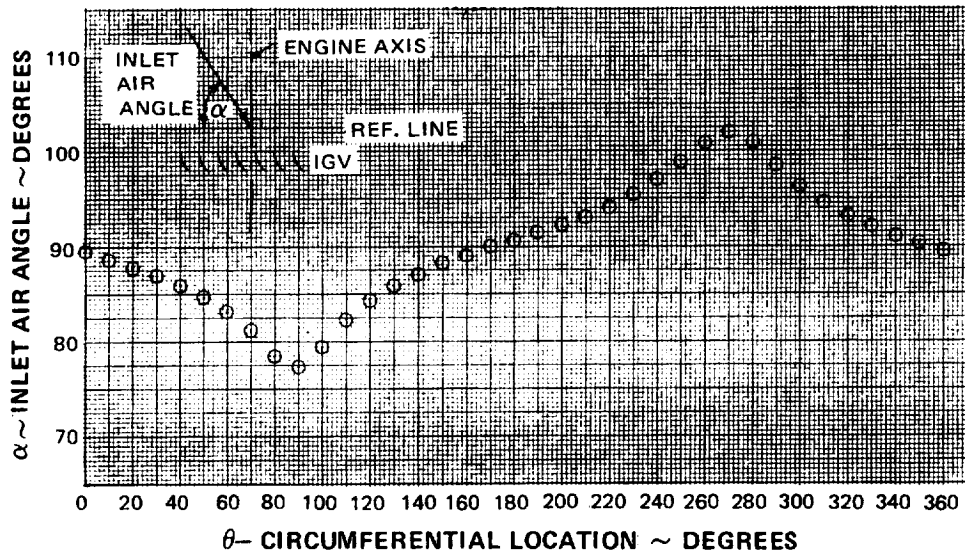

Figure 13 Circumferential Variation of Inlet Air Angle at 8600 rpm

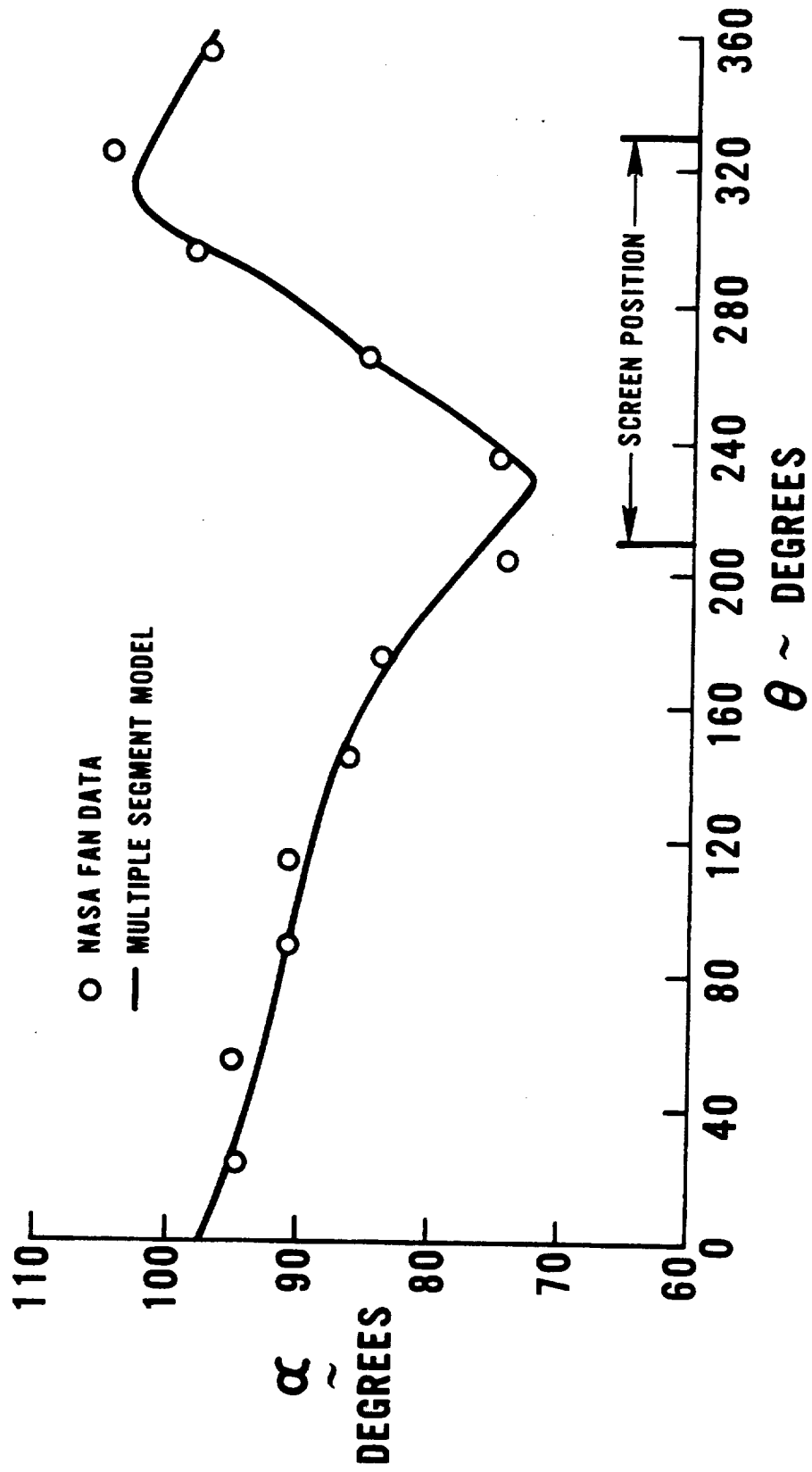

Figure 14 Inlet Air Angle Variation For a NASA Fan Stage

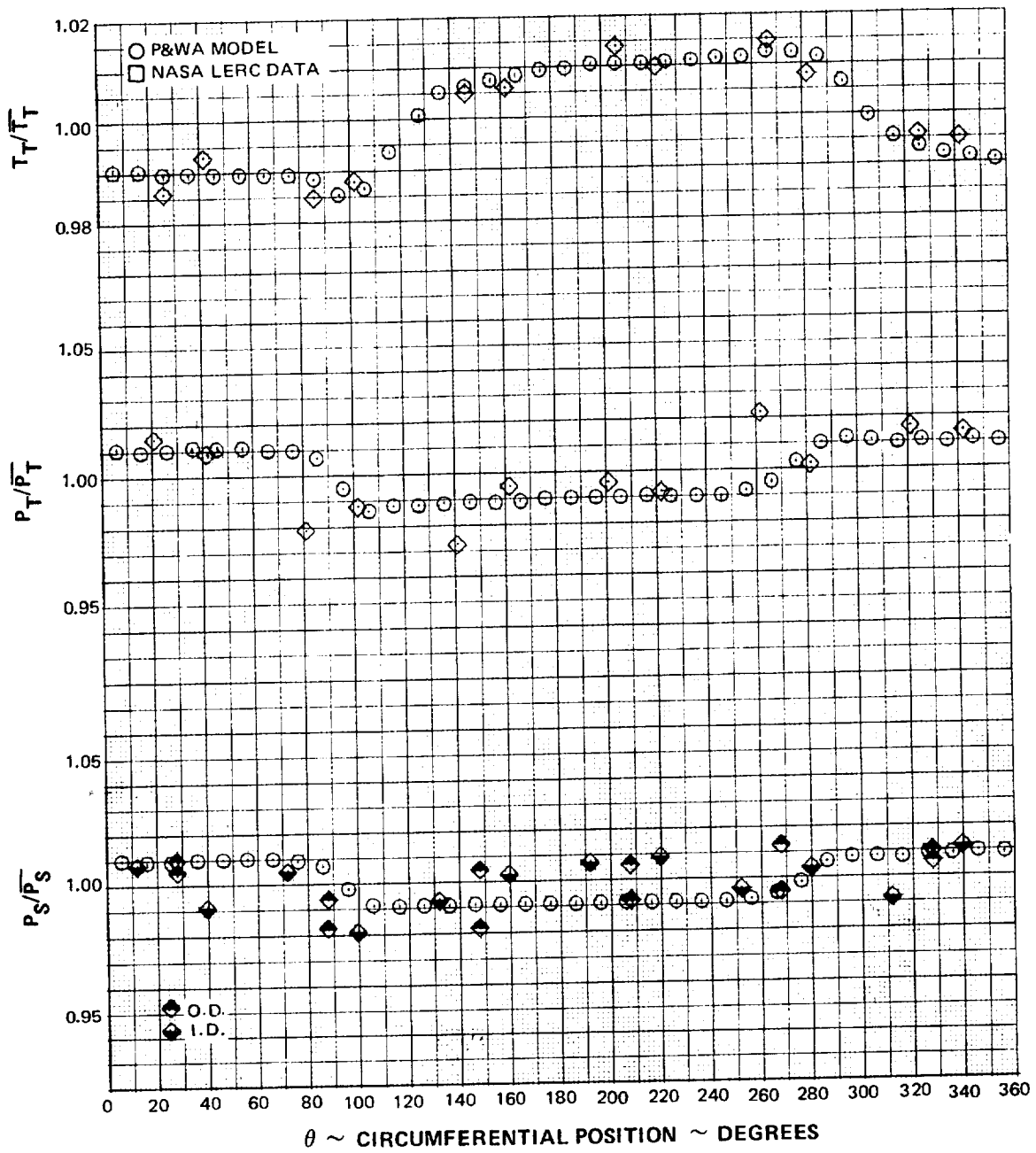

Figure 15 Circumferential Variation of Pressure and Temperature at Station 2.3F at 8600 rpm

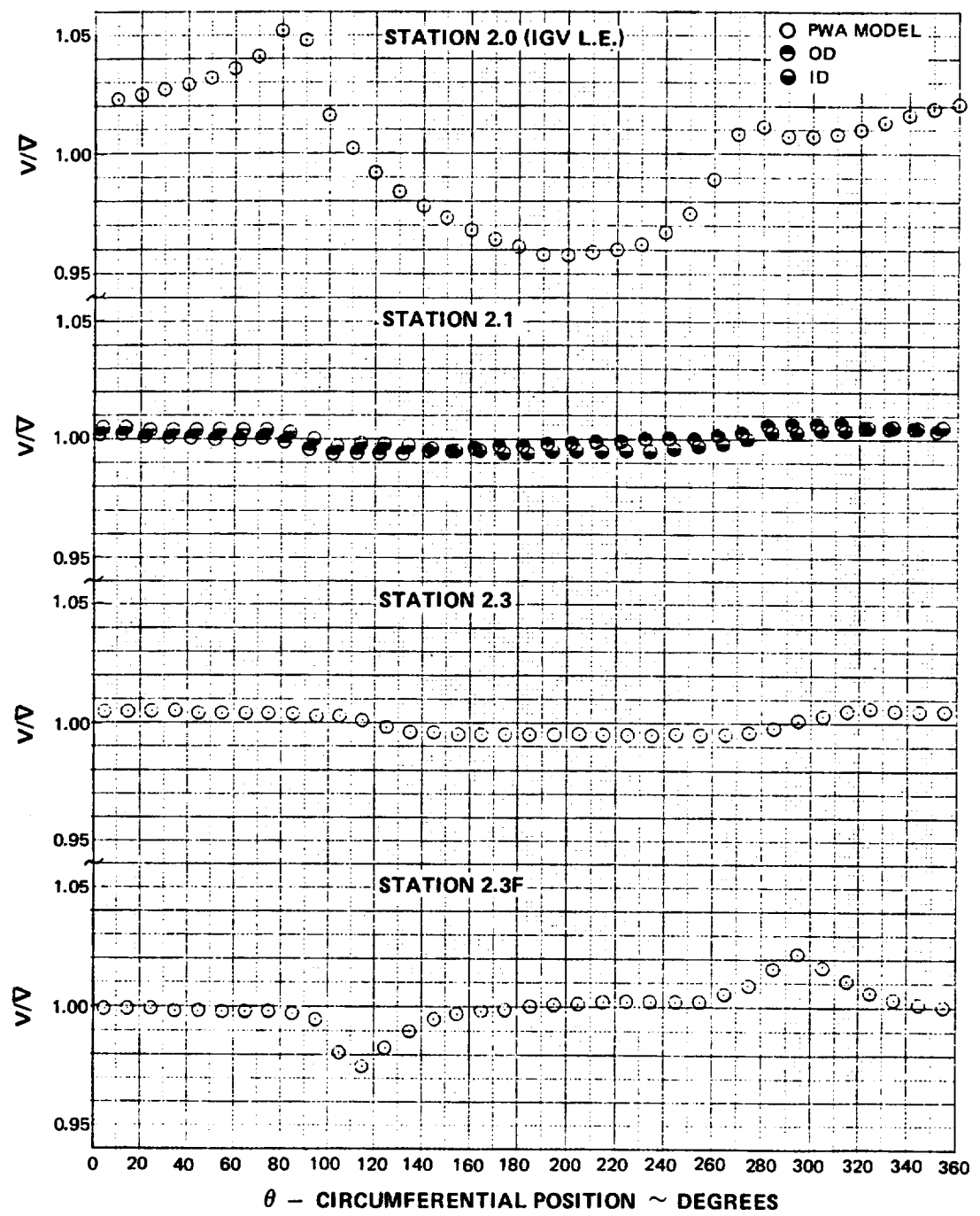

Figure 16 Circumferential Variation of Velocity at Stations 2.0, 2.1, 2.3, and 2.3F at 8600 rpm

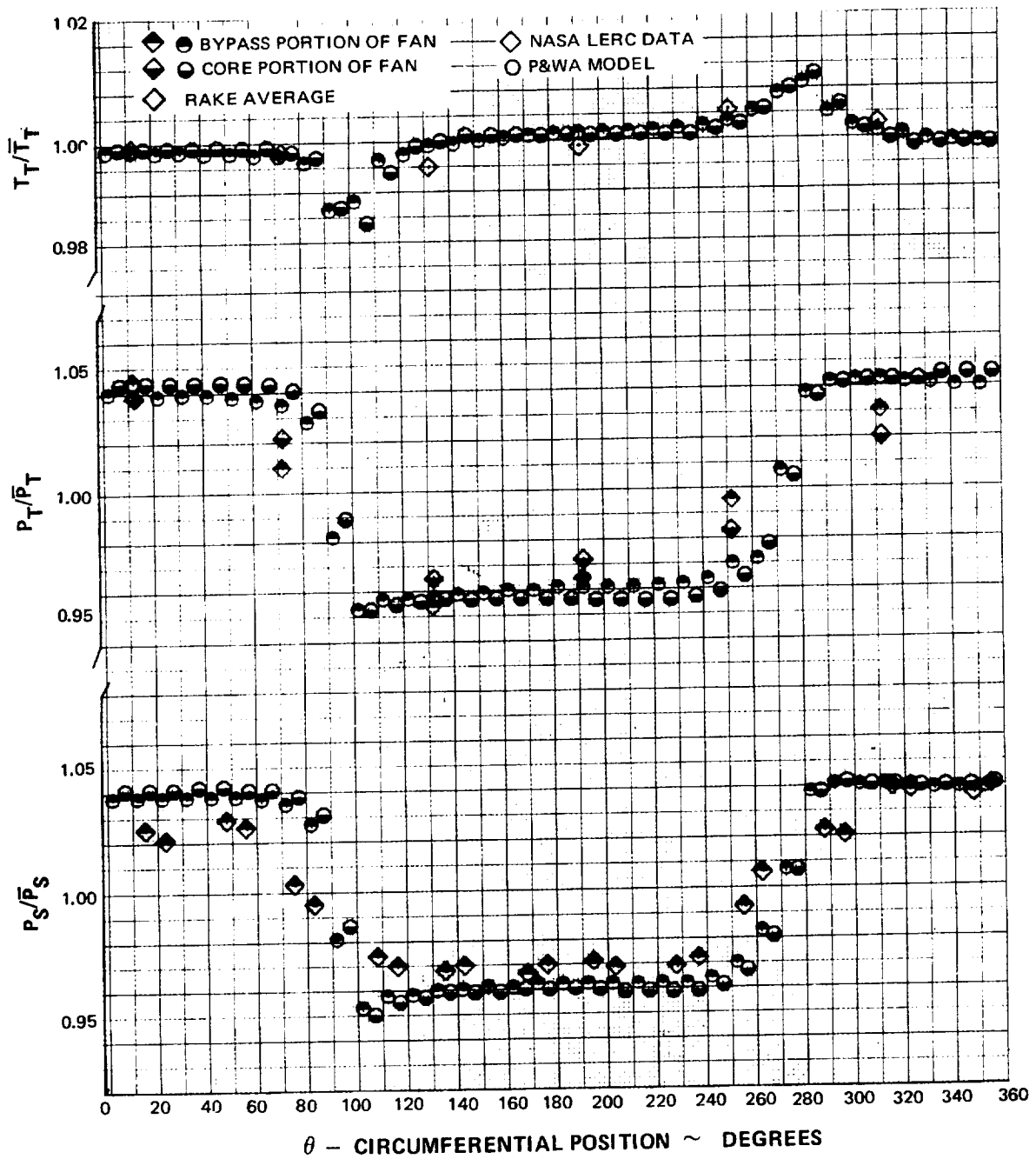

Figure 17 Circumferential Variation of Pressure and Temperature at Station 2.1 at 8600 rpm

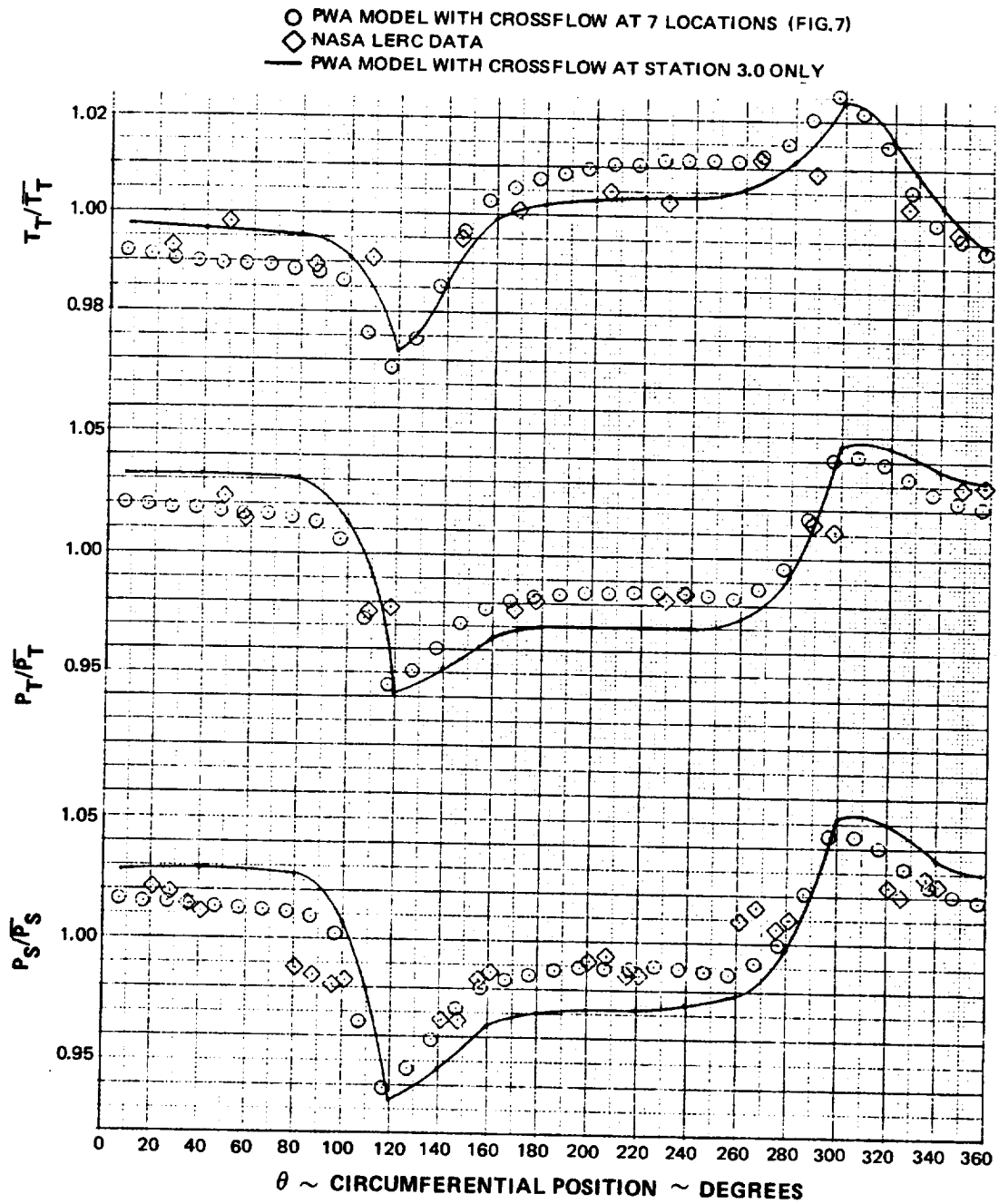

Figure 18 Circumferential Variation of Pressure and Temperature at Station 2.3 at 8600 rpm

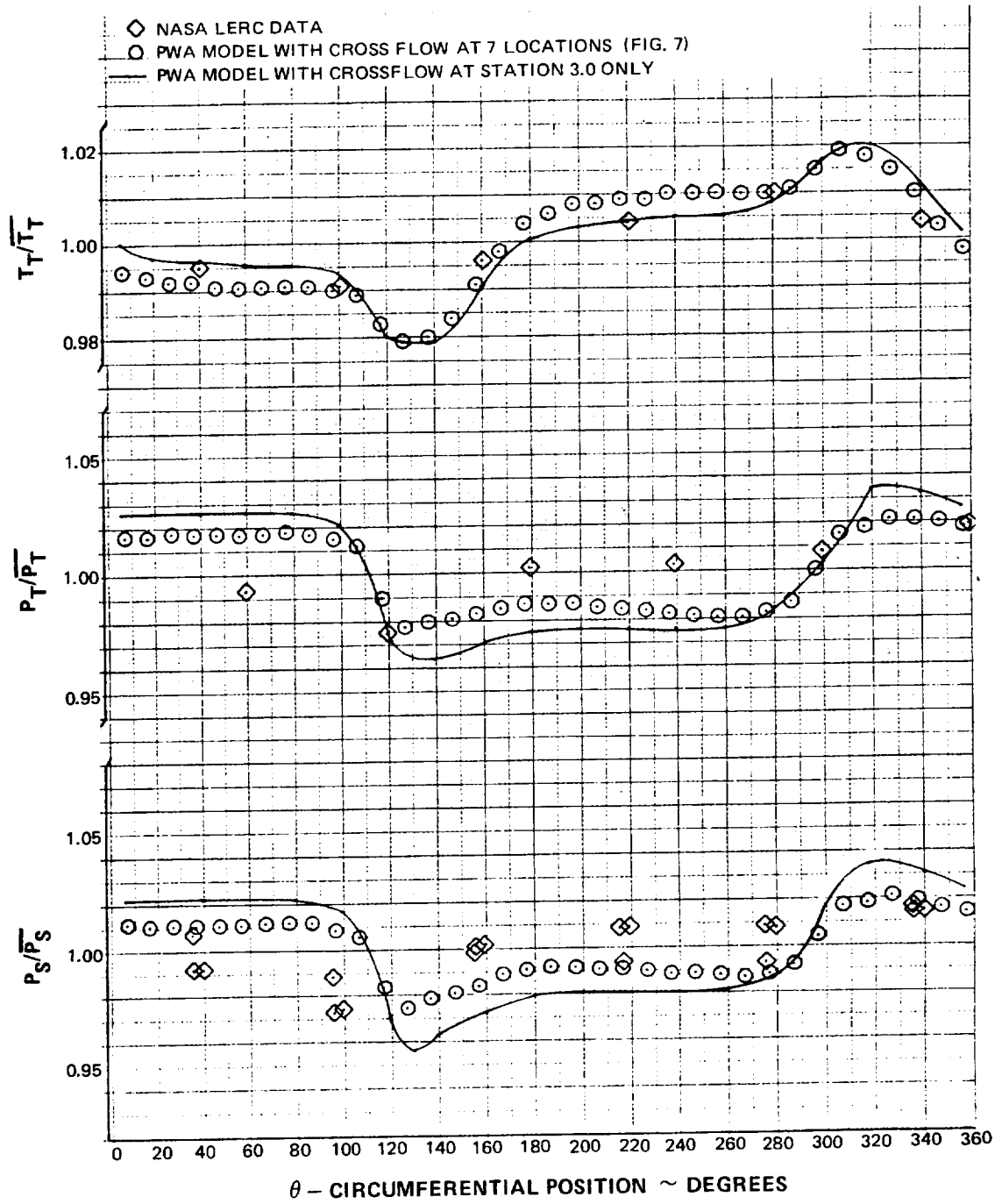

Figure 19 Circumferential Variation of Pressure and Temperature at Station 2.6 at 8600 rpm

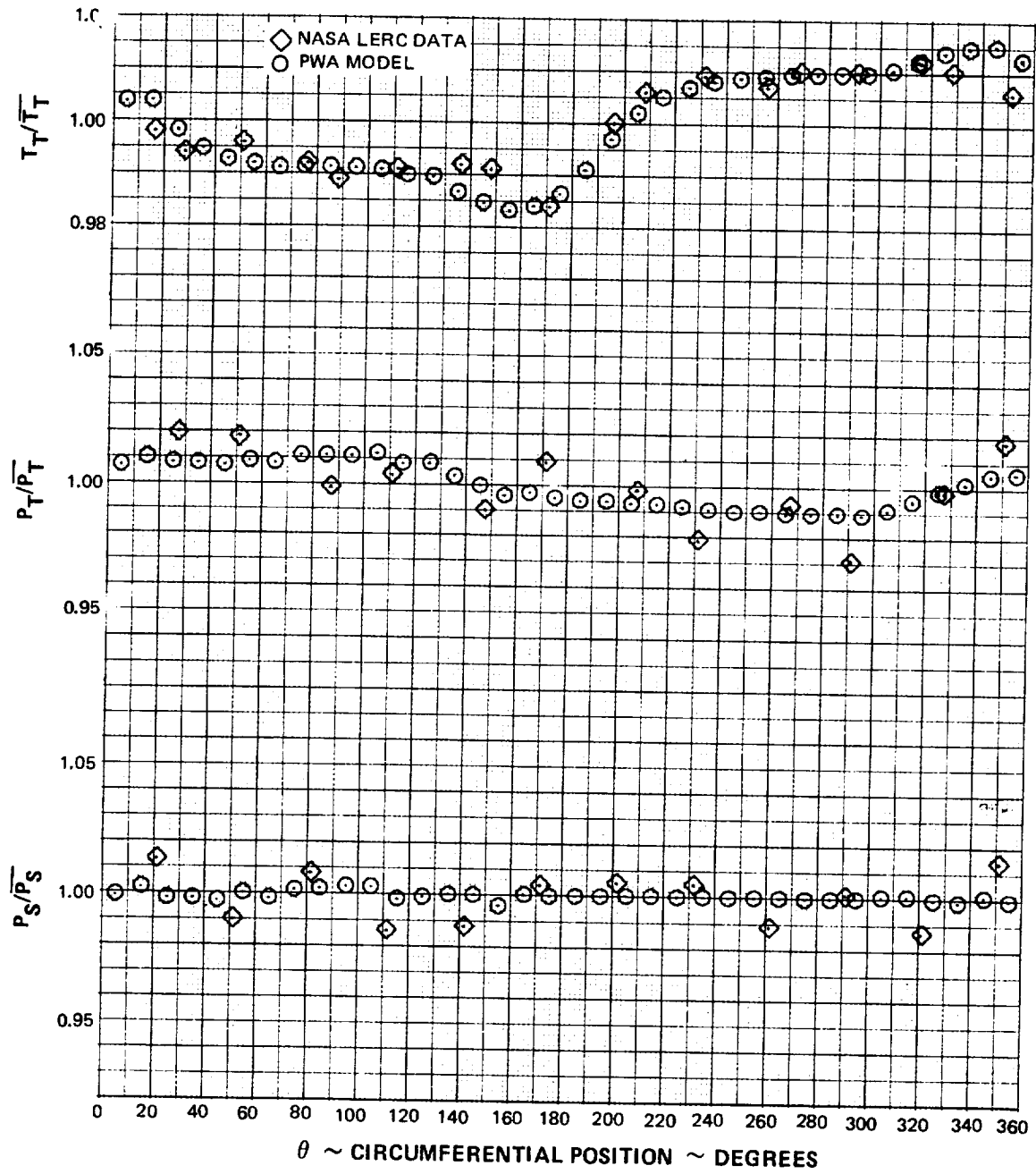

Figure 20 Circumferential Variation of Pressure and Temperature at Station 3.0 at 8600 rpm

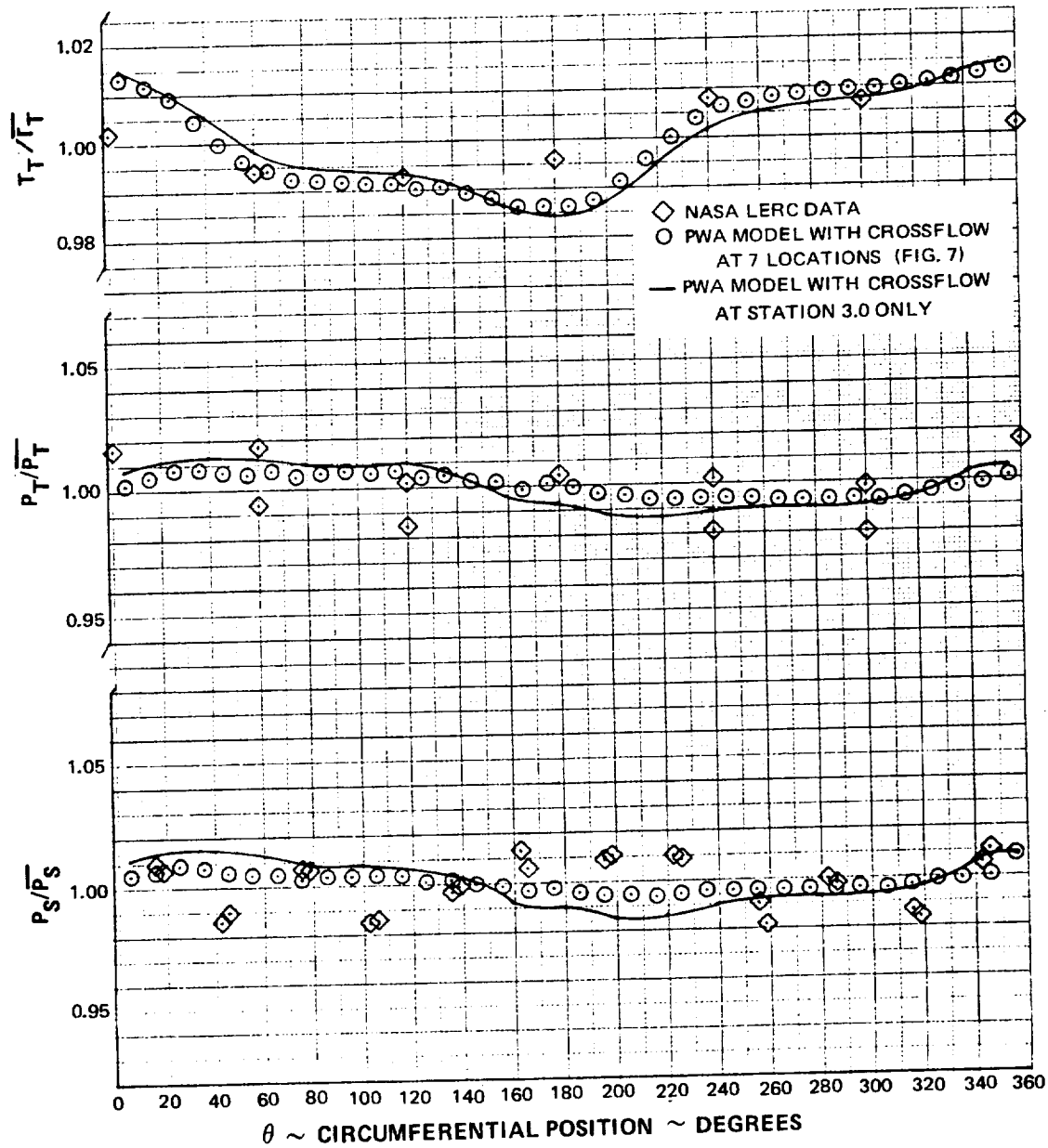

Figure 21 Circumferential Variation of Pressure and Temperature at Station 3.12 at 8600 rpm

REPRODUCIBILITY OF THE ORIGINAL PAGE IS DOOR

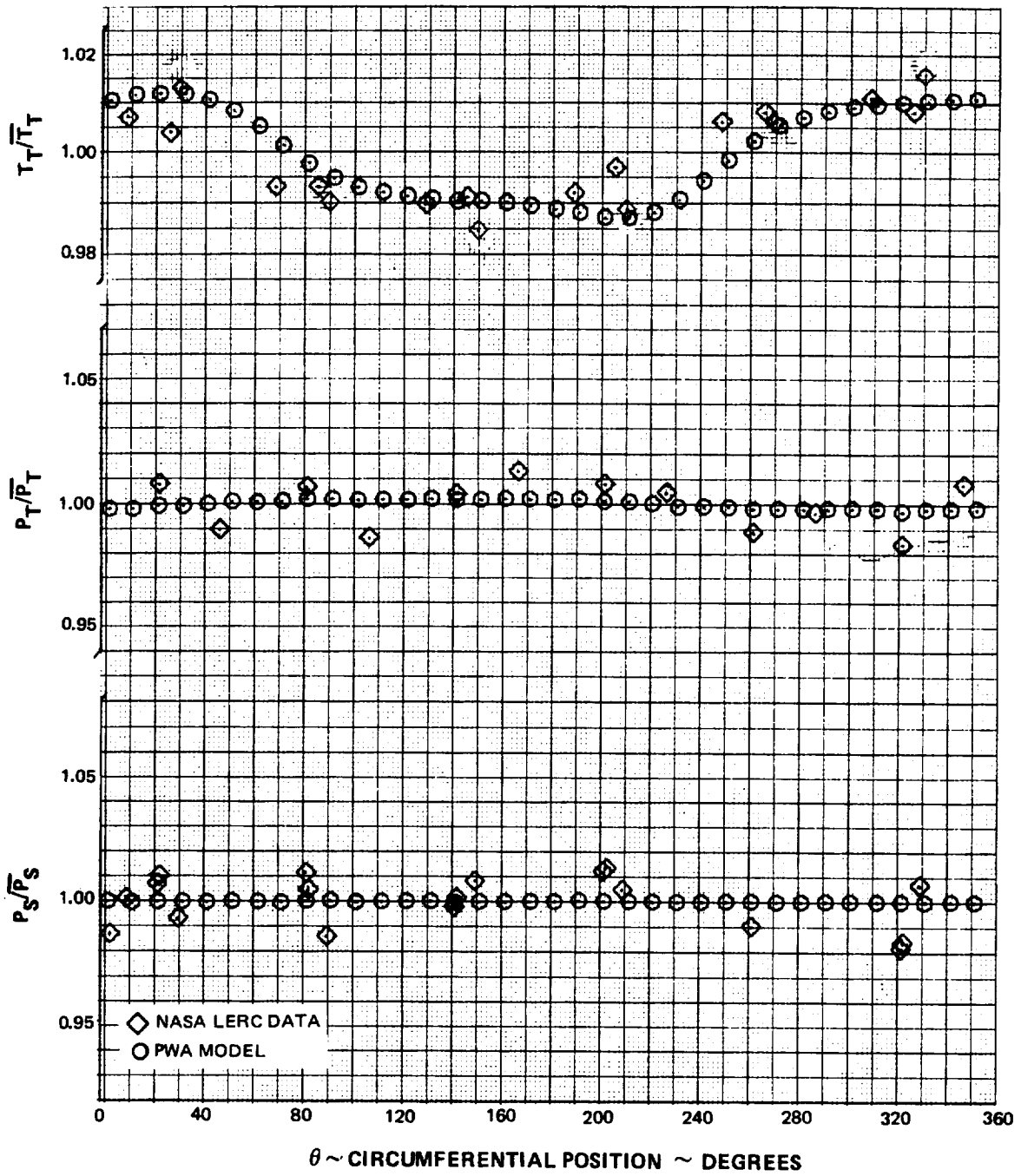

Figure 22 Circumferential Variation of Pressure and Temperature at Station 4.0 at 8600 rpm

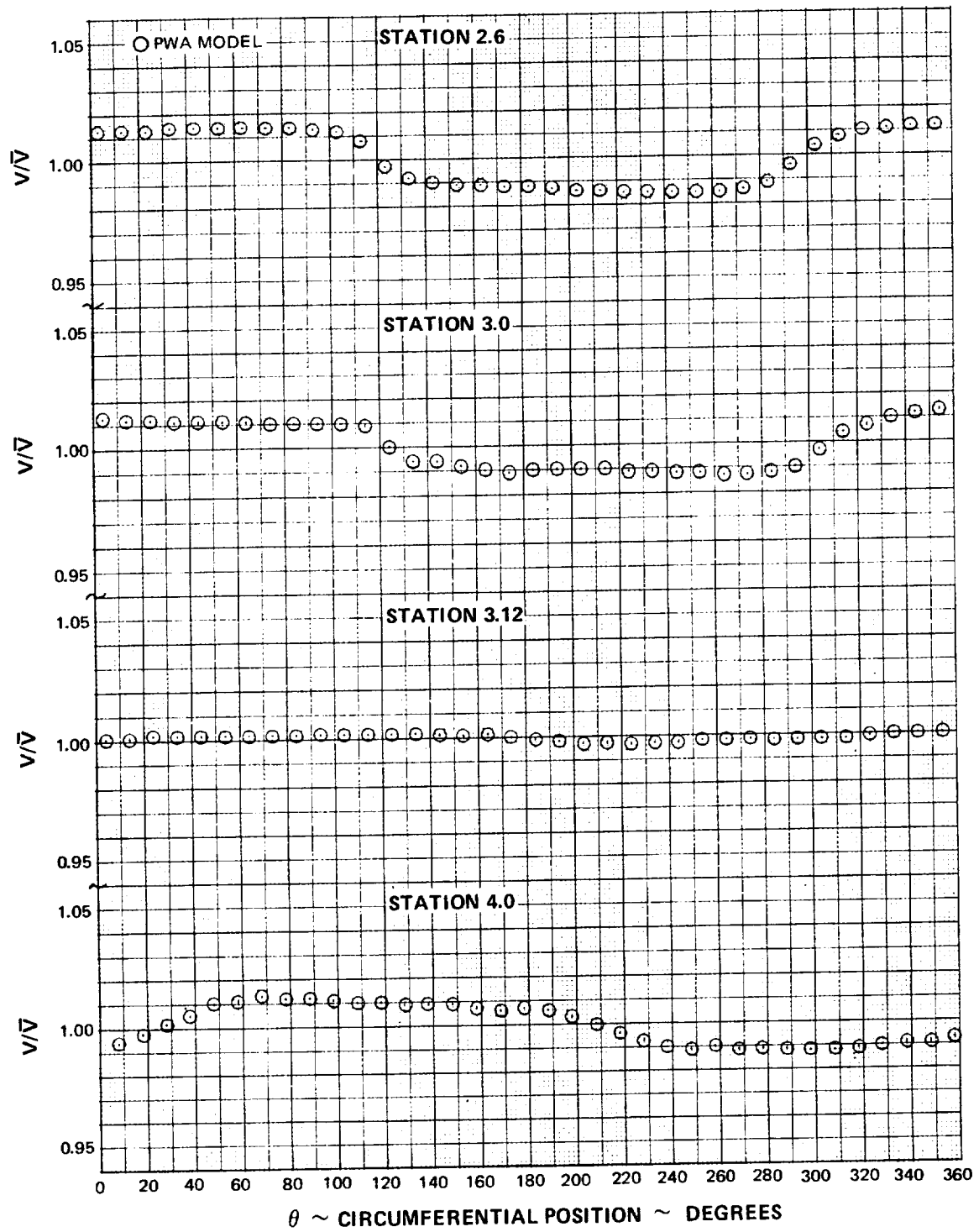

Figure 23 Circumferential Variation of Velocity at Stations 2.6, 3.0, 3.12 and 4.0 at 8600 rpm

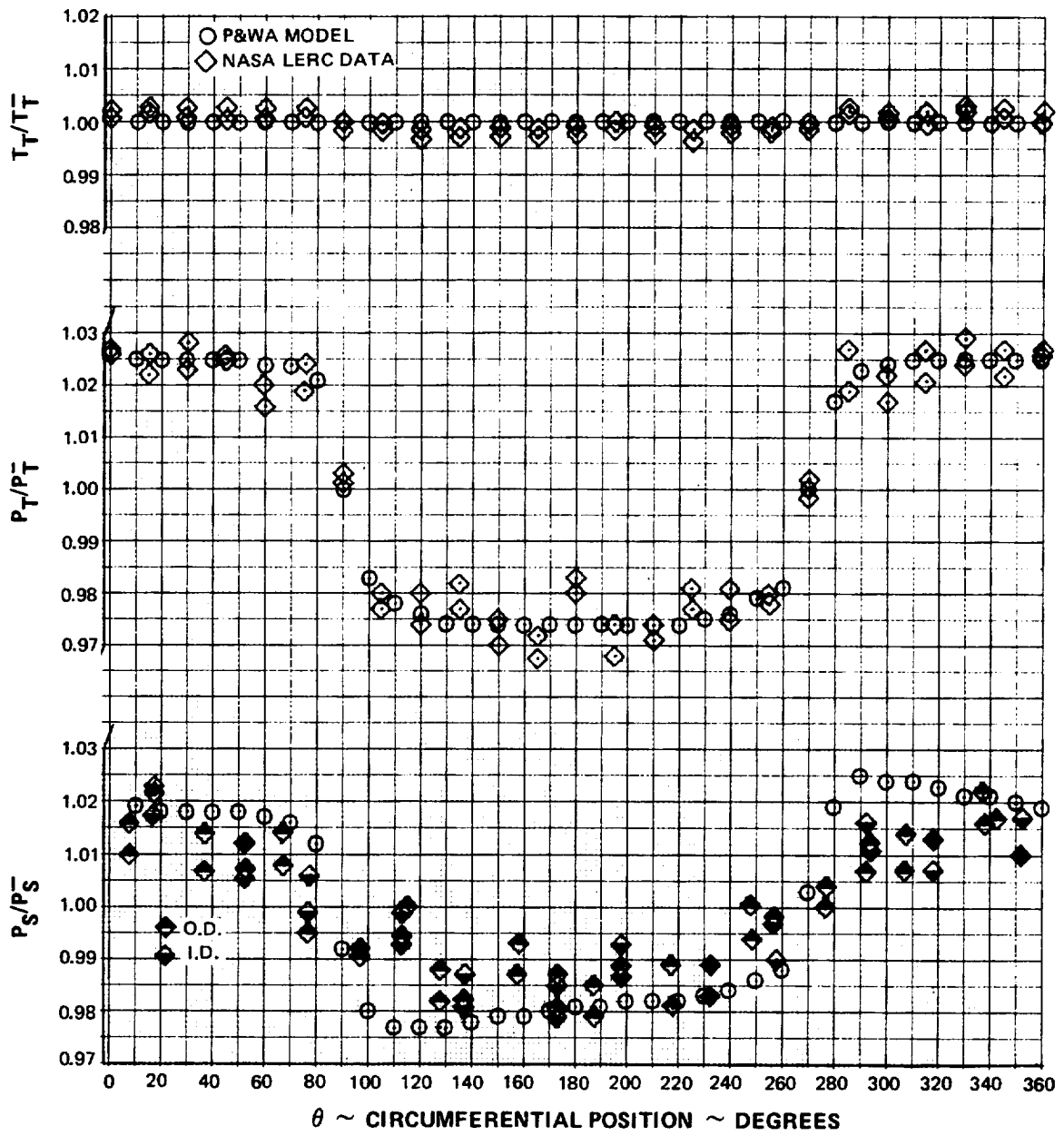

Figure 24 Circumferential Variation of Inlet Pressure and Temperature at 7400 rpm

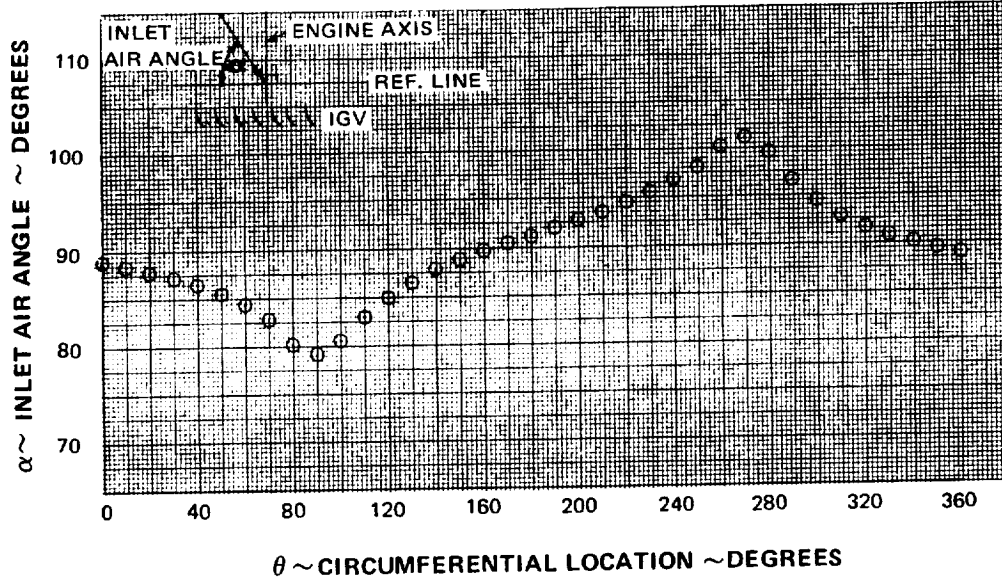

Figure 25 Circumferential Variation of Inlet Air Angle at 7400 rpm

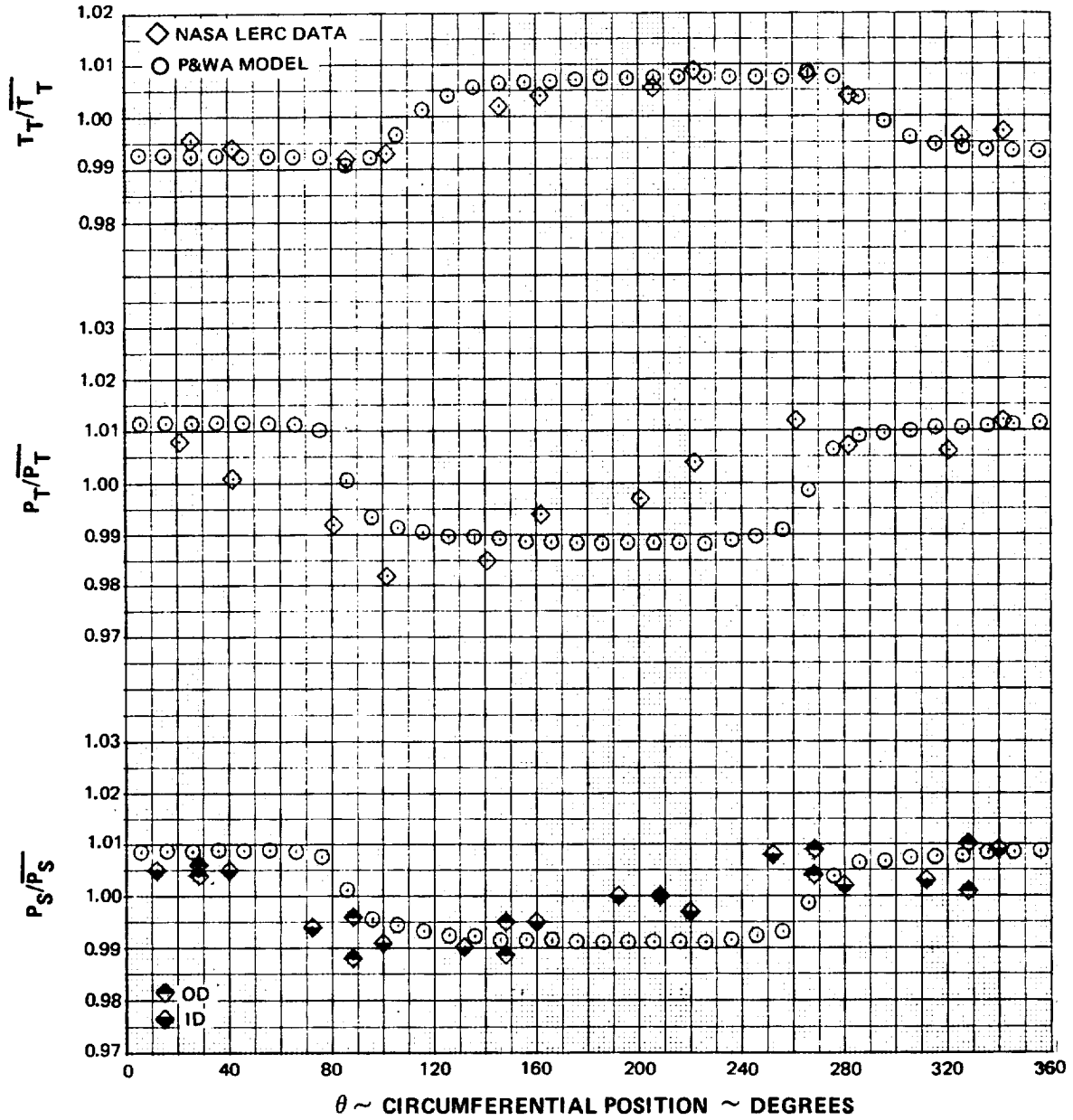

Figure 26 Circumferential Variation of Pressure and Temperature at Station 2.3F at 7400 rpm

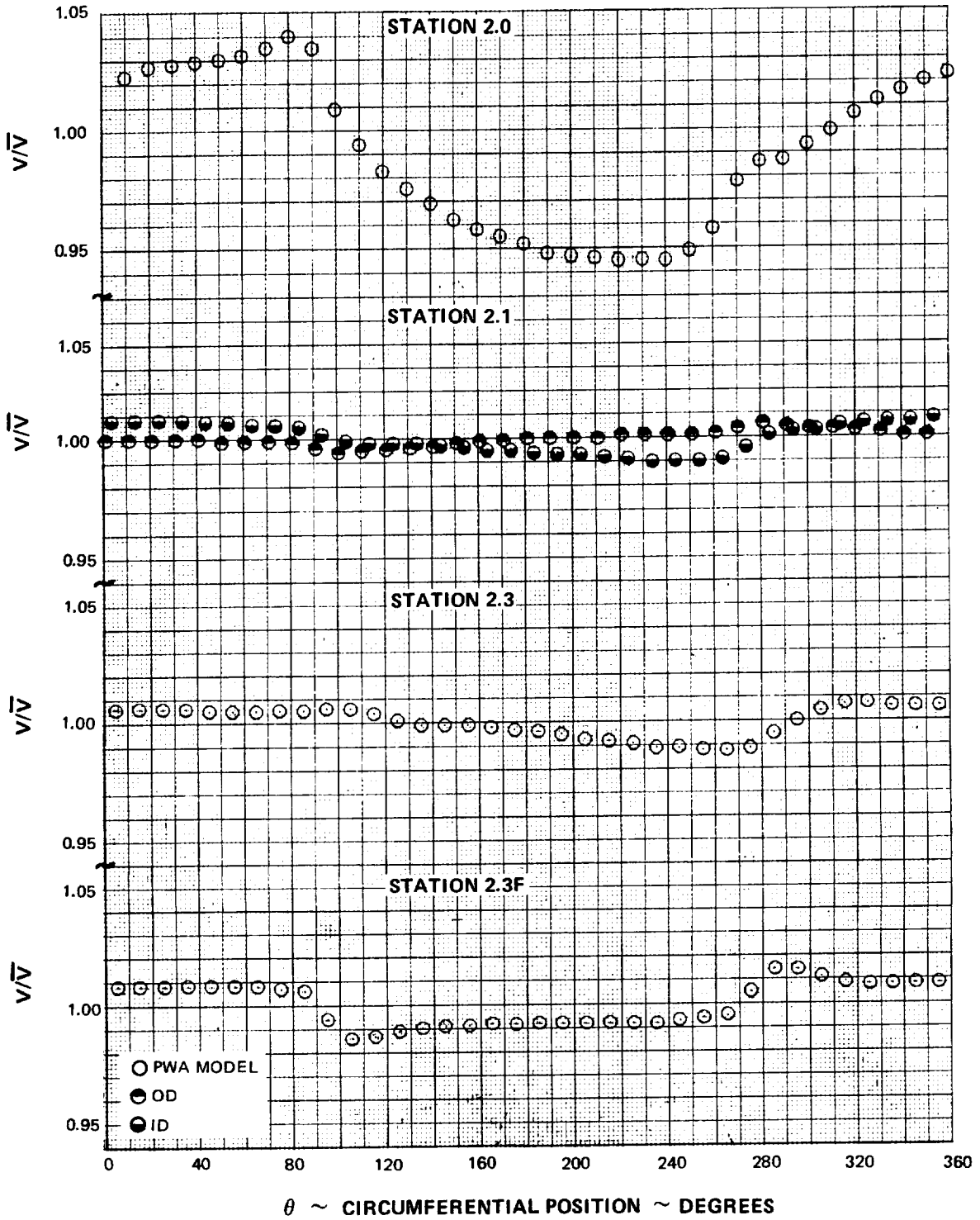

Figure 27 Circumferential Variation of Velocity at Stations 2.0, 2.1, 2.3, and 2.3F at 7400 rpm

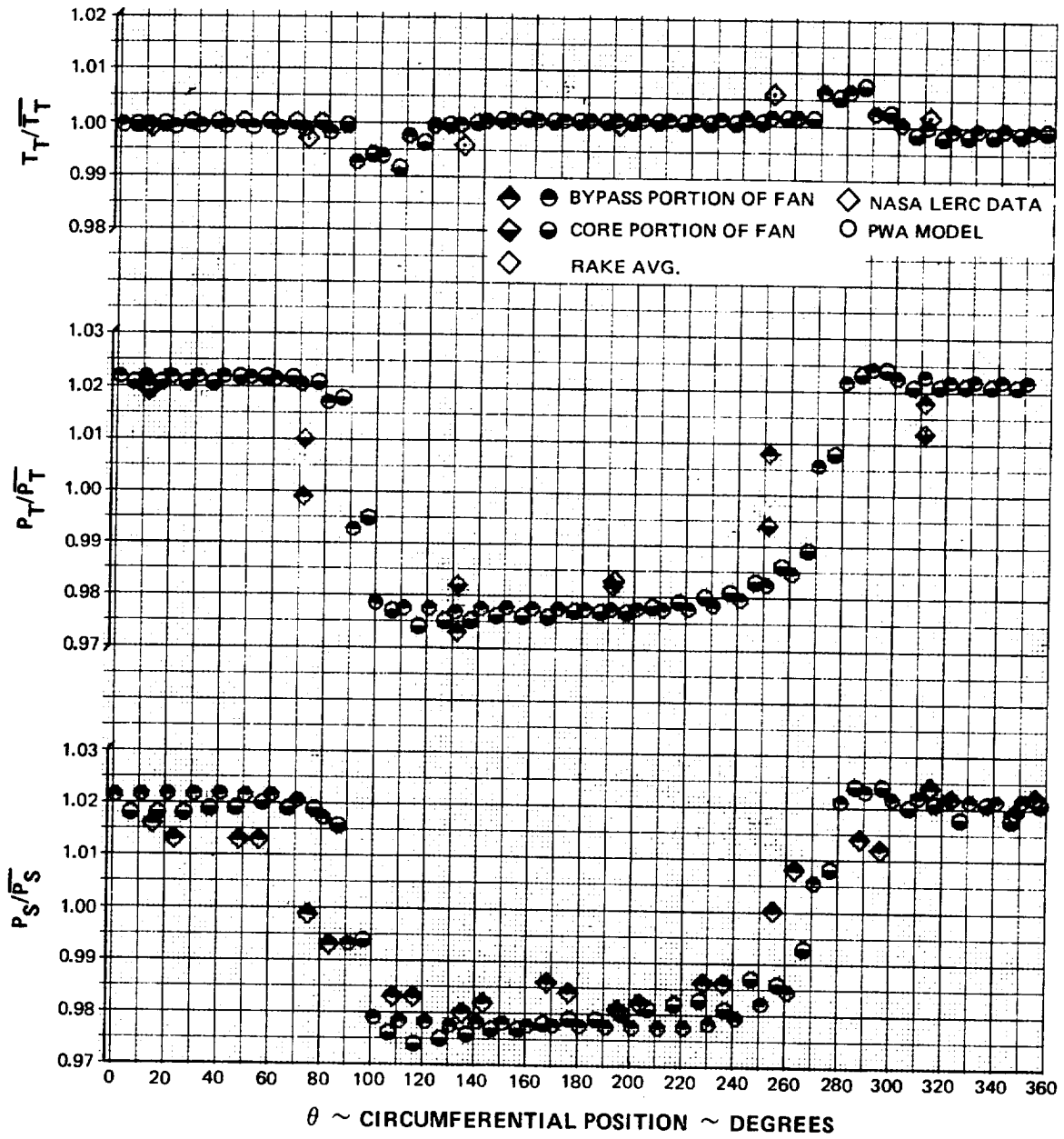

Figure 28 Circumferential Variation of Pressure and Temperature at Station 2.1 at 7400 rpm

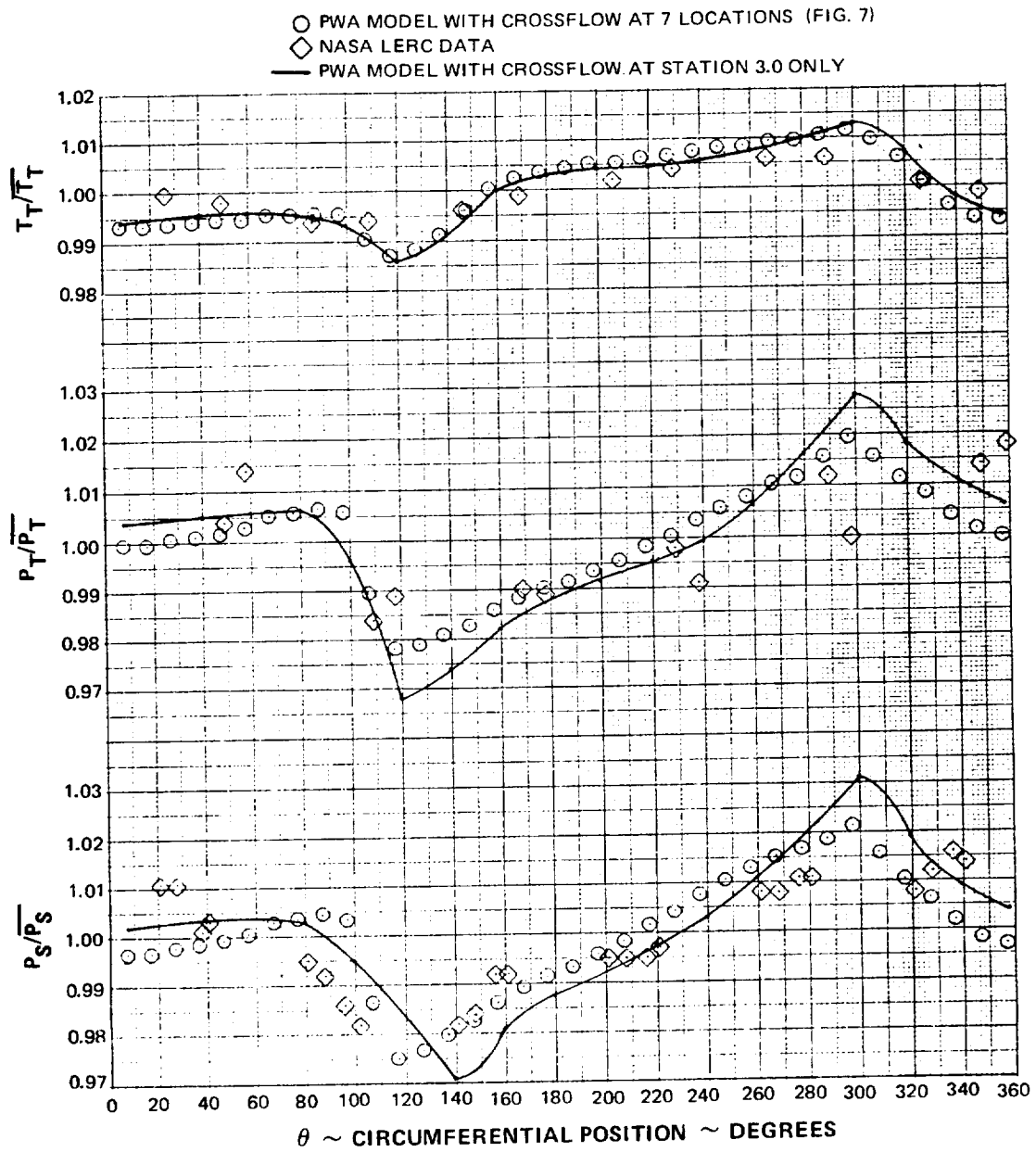

Figure 29 Circumferential Variation of Pressure and Temperature at Station 2.3 at 7400 rpm

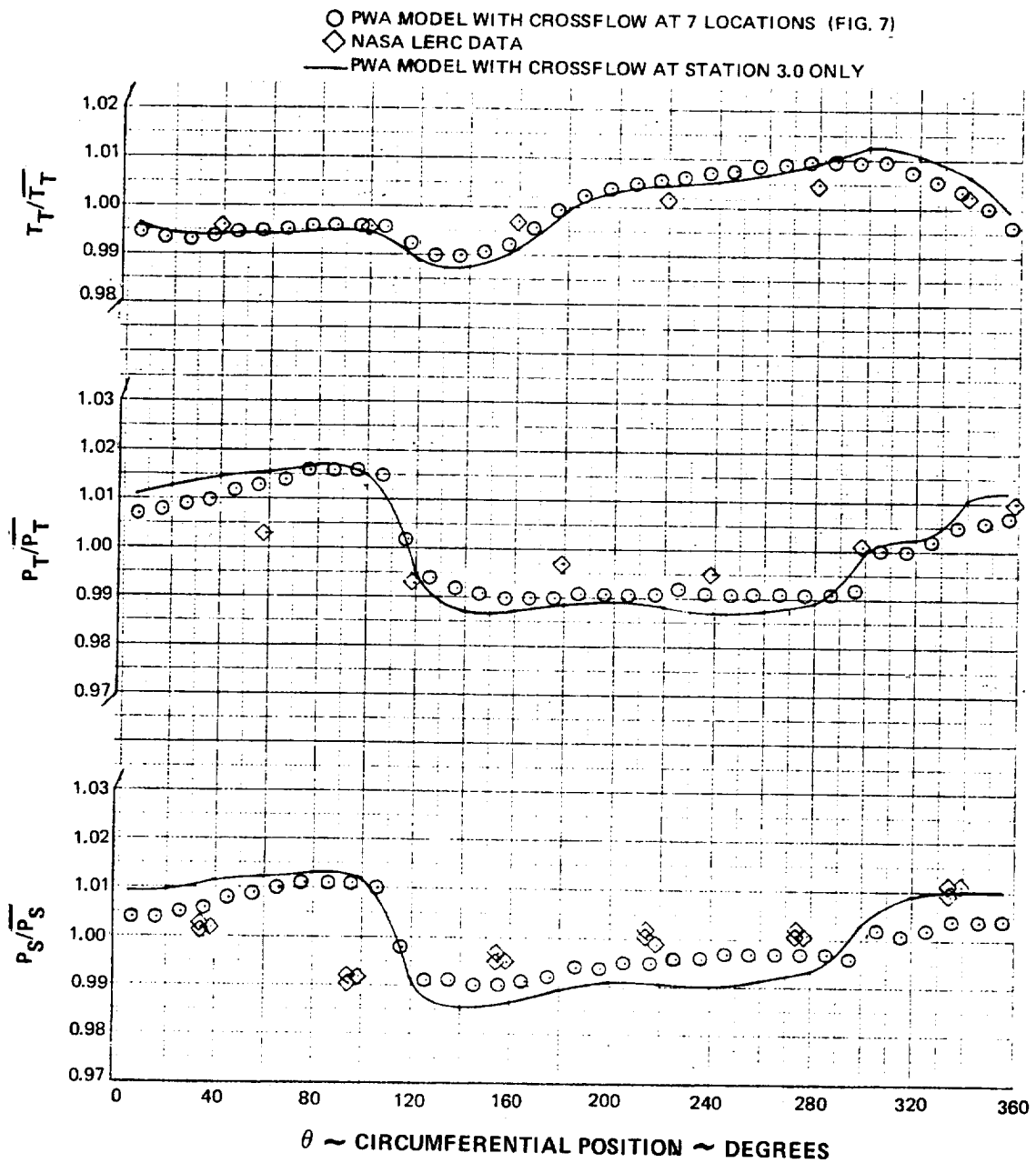

Figure 30 Circumferential Variation of Pressure and Temperature at Station 2.6 at 7400 rpm

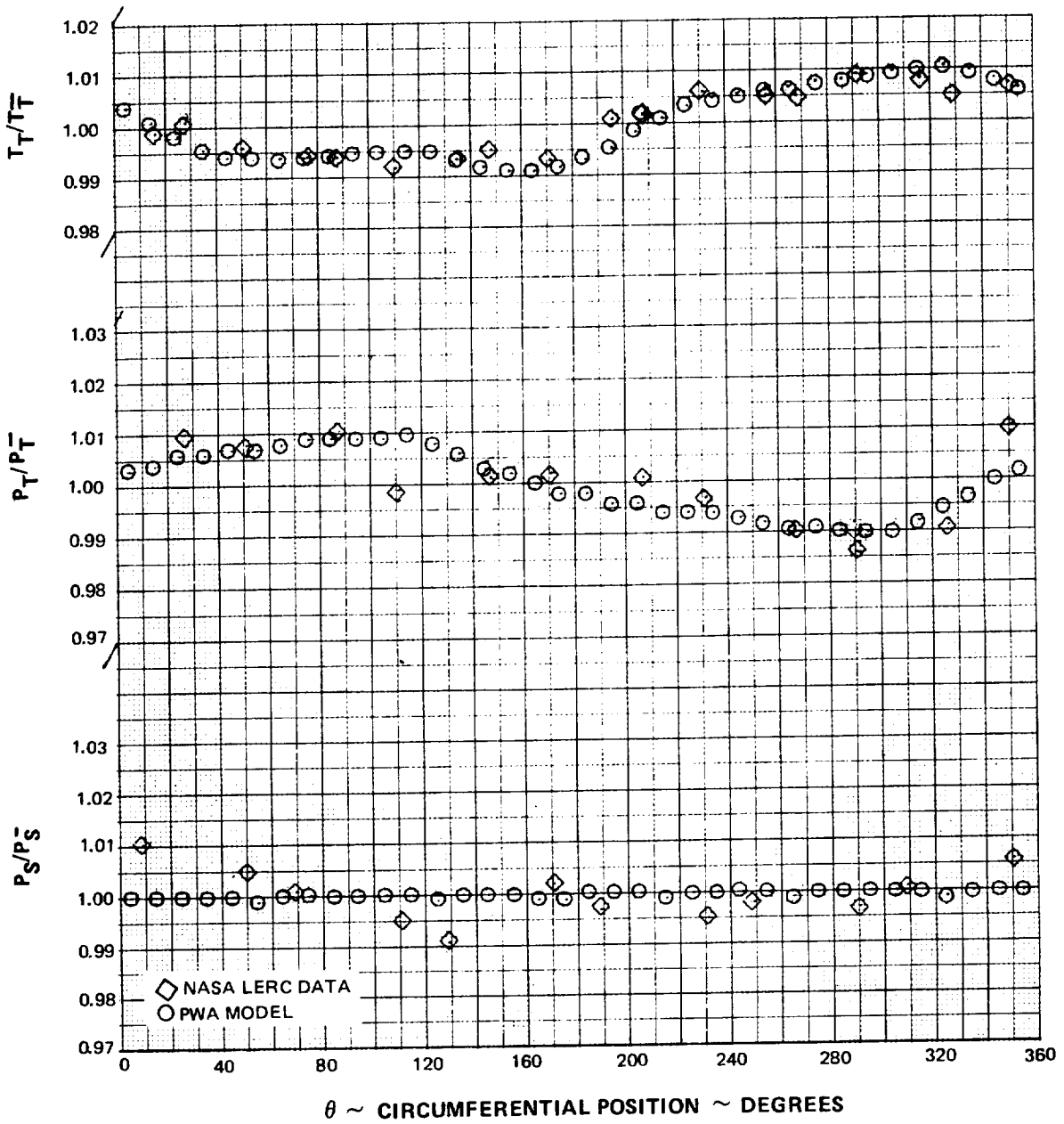

Figure 31 Circumferential Variation of Pressure and Temperature at Station 3.0 at 7400 rpm

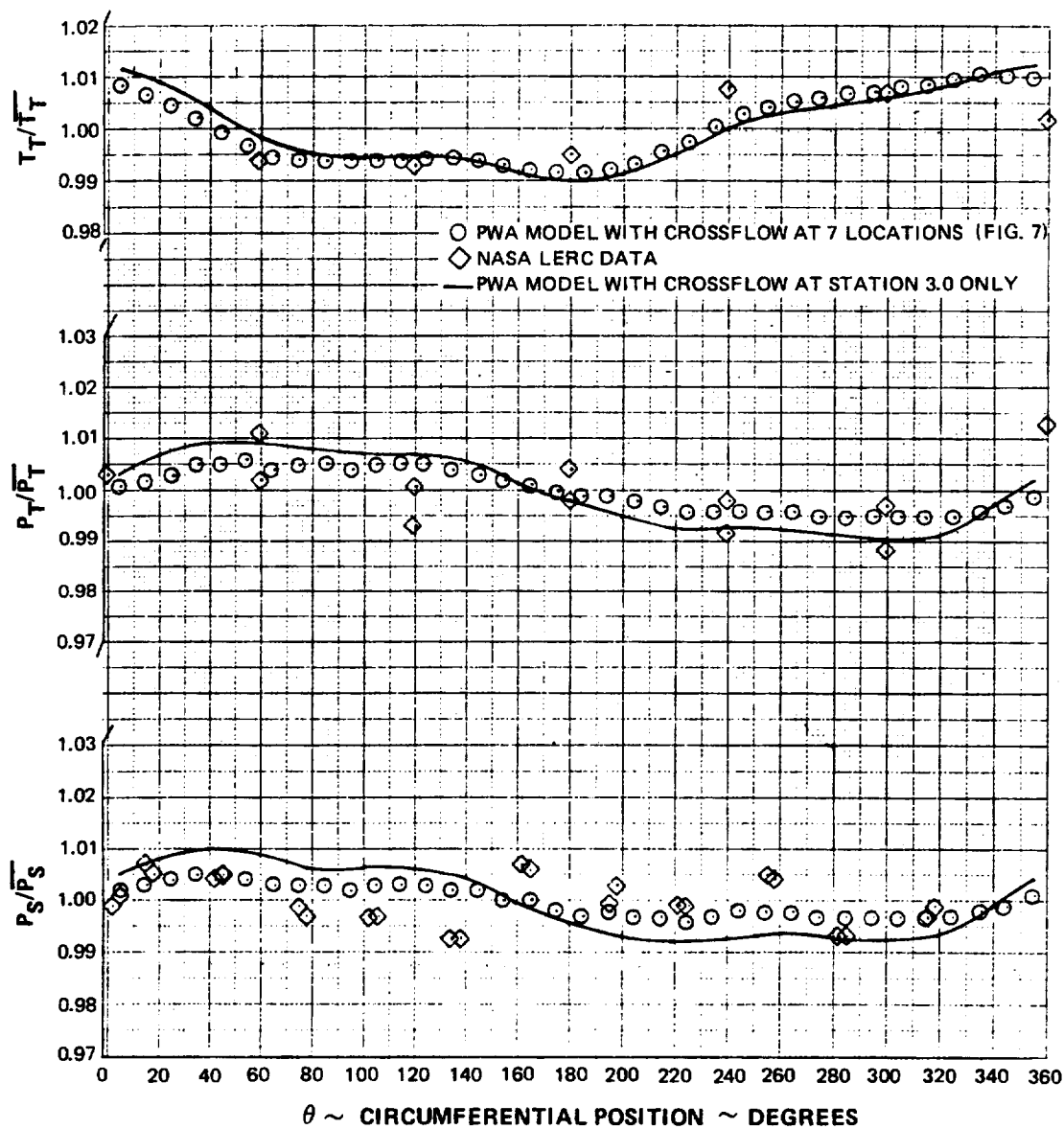

Figure 32 Circumferential Variation of Pressure and Temperature at Station 3.12 at 7400 rpm

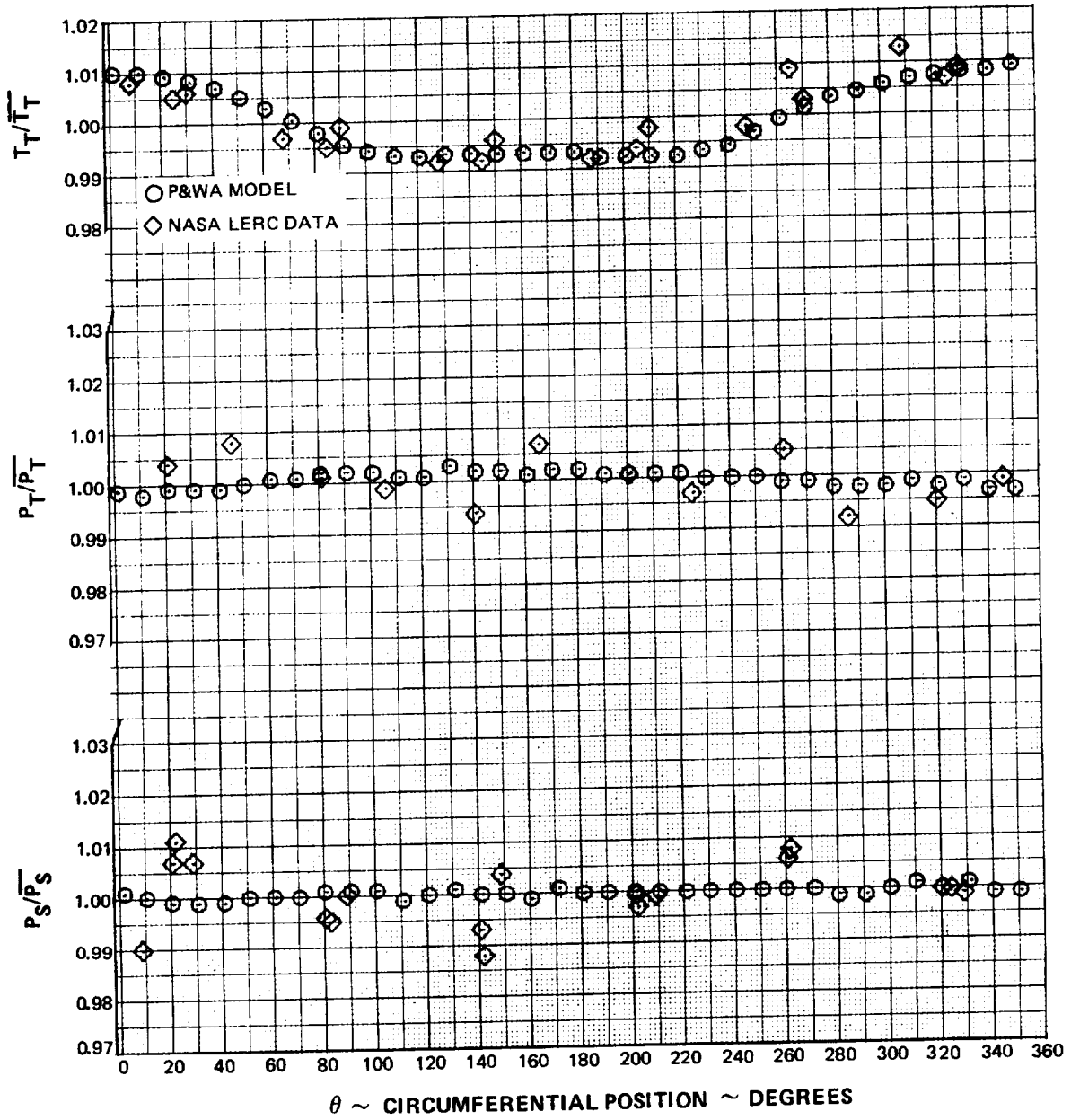

Figure 33 Circumferential Variation of Pressure and Temperature at Station 4.0 at 7400 rpm

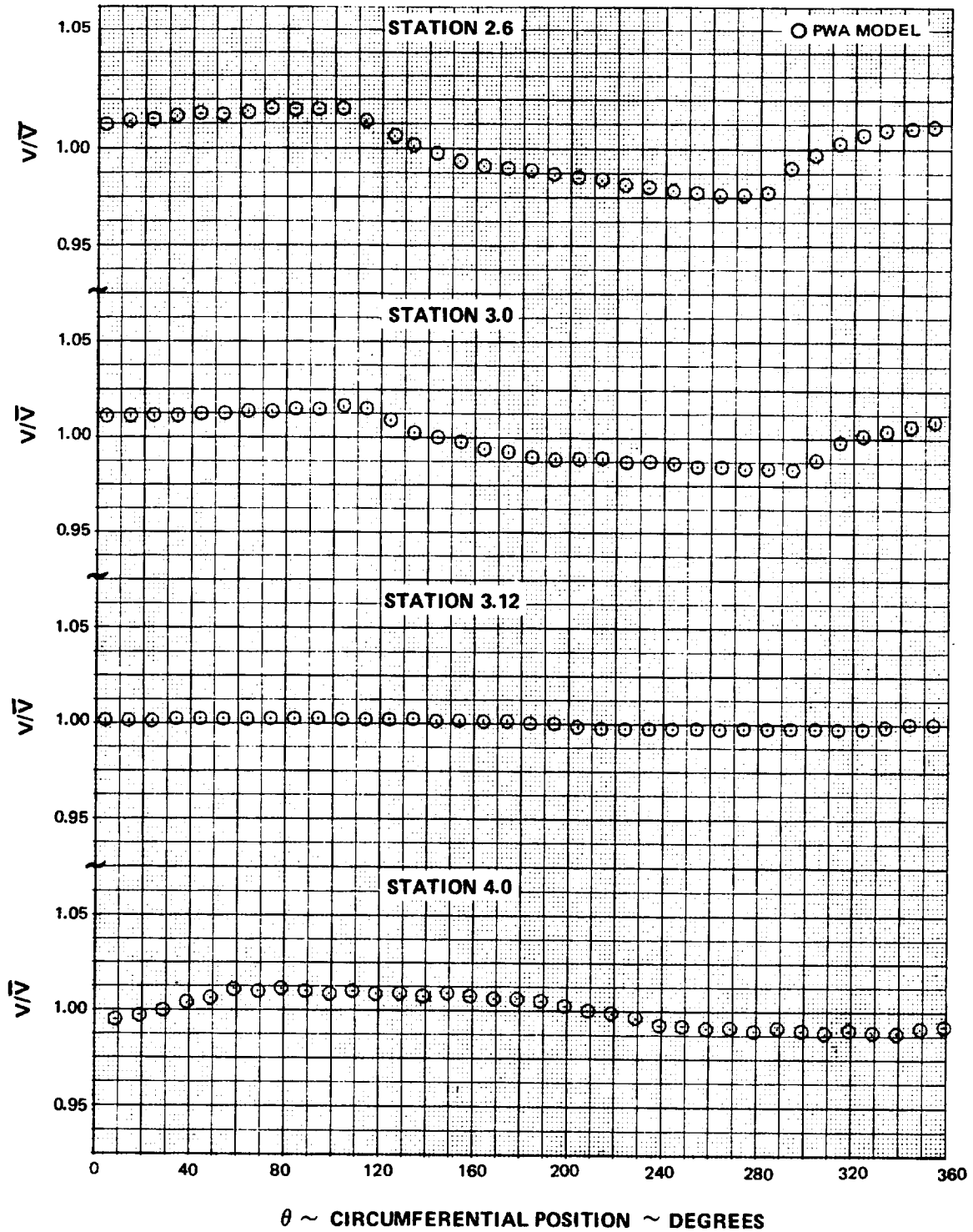

Figure 34 Circumferential Variation of Velocity at Stations 2.6, 3.0, 3.12 and 4.0 at 7400 rpm

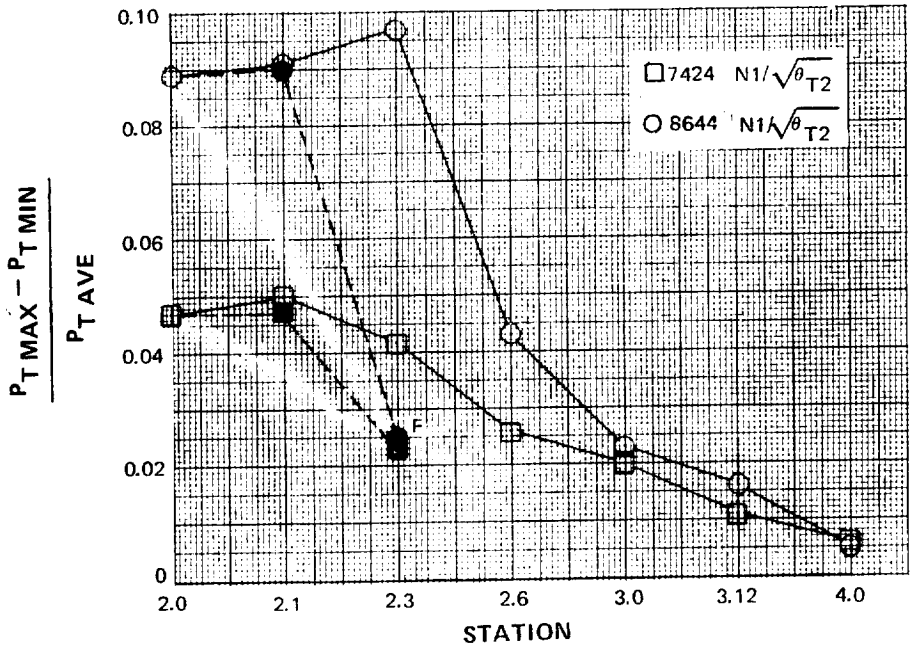

Figure 35 Predicted Attenuation of Total Pressure

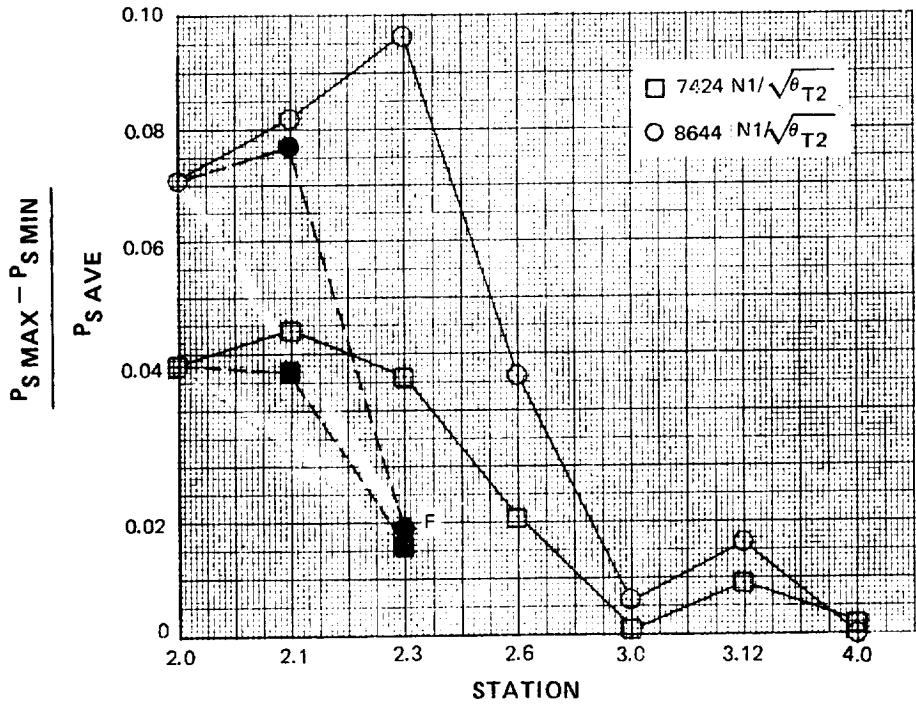

Figure 36 Predicted Attenuation of Static Pressure Distortion

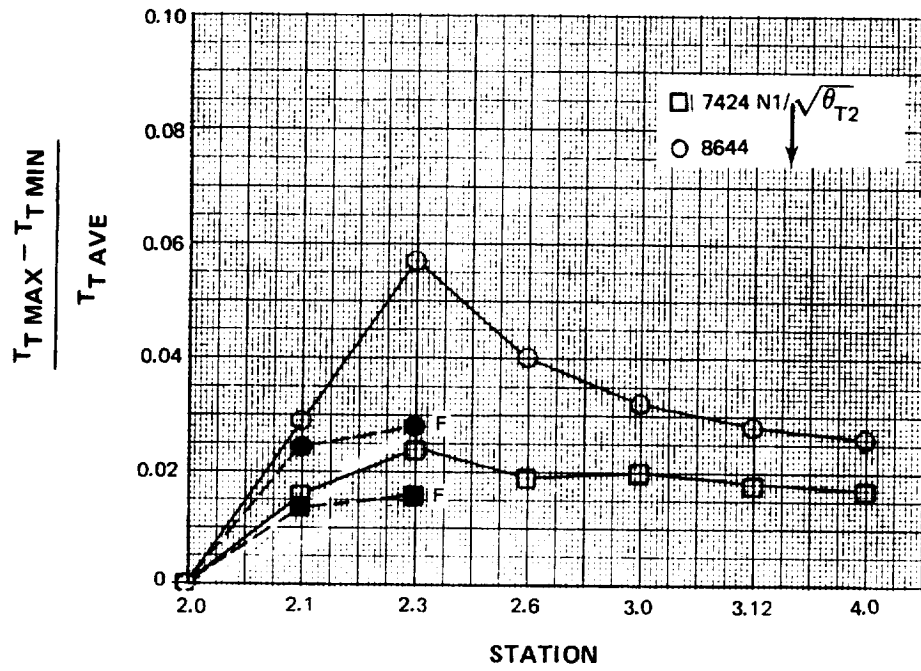

Figure 37 Predicted Generation of Total Temperature Distortion

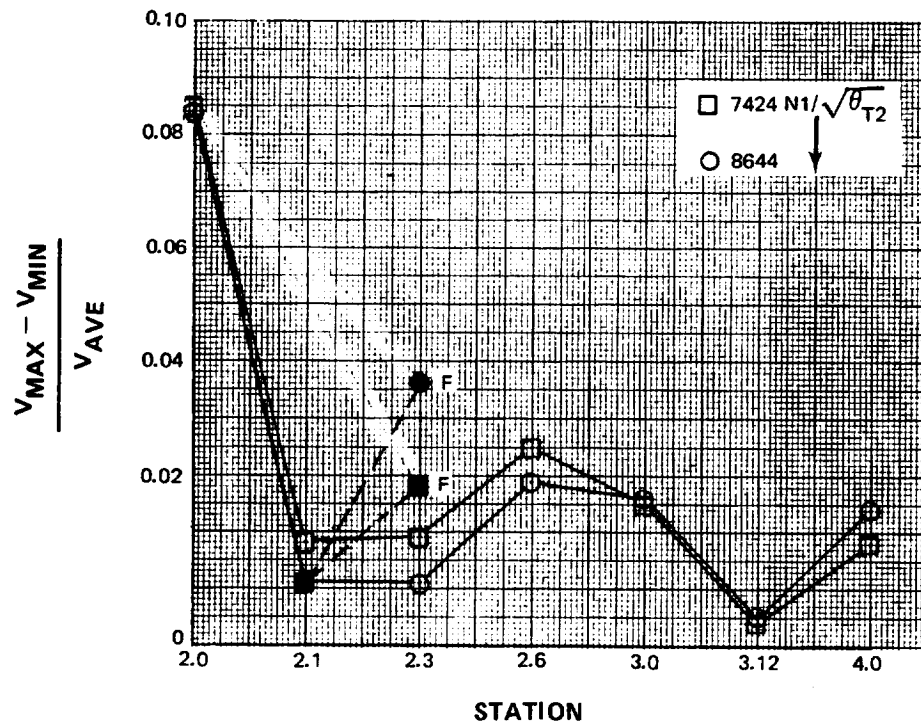

Figure 38 Predicted Velocity Distortion

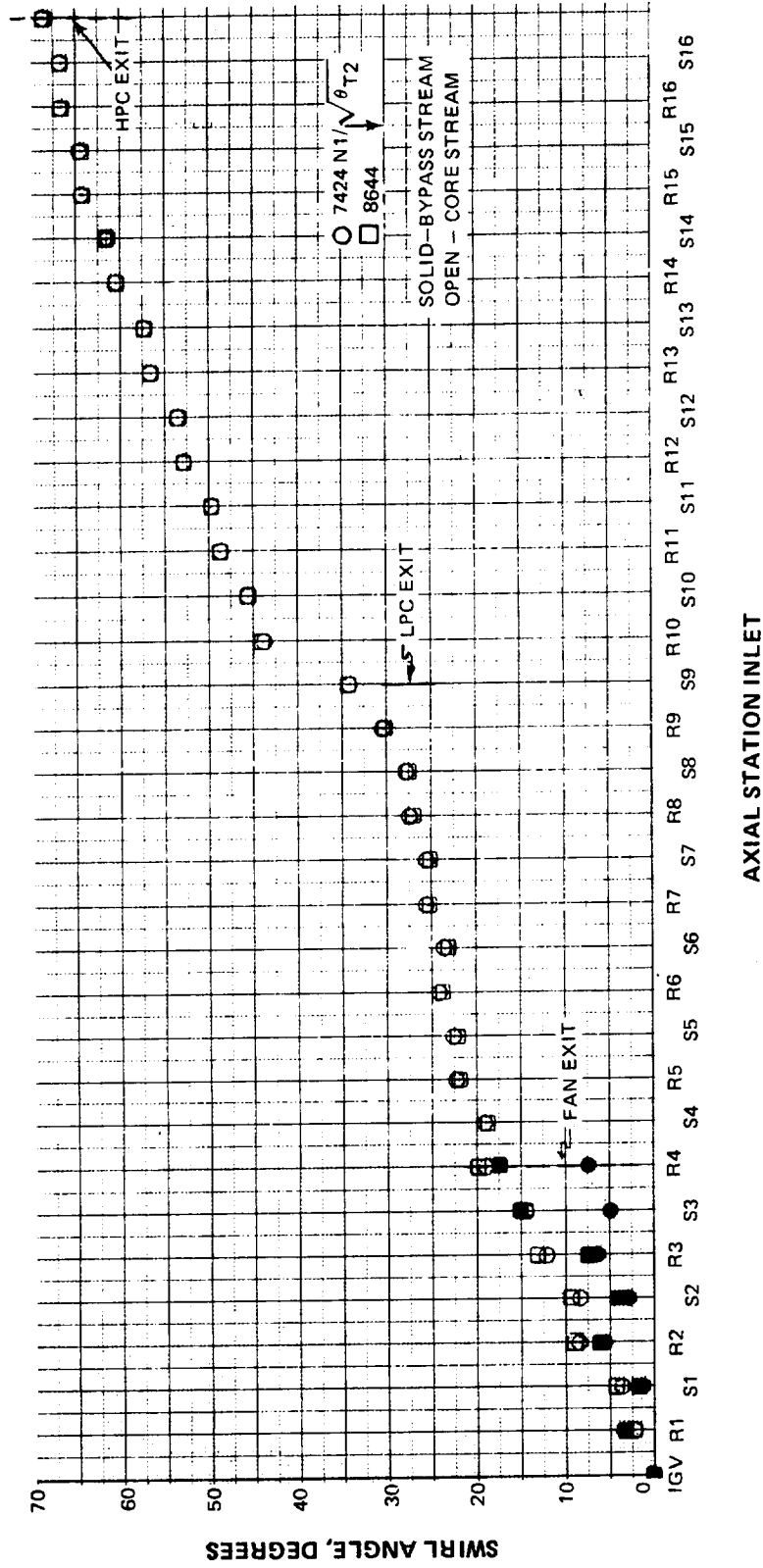

Figure 39 Predicted Flow Swirl (Acoustic Path) through Compressor System

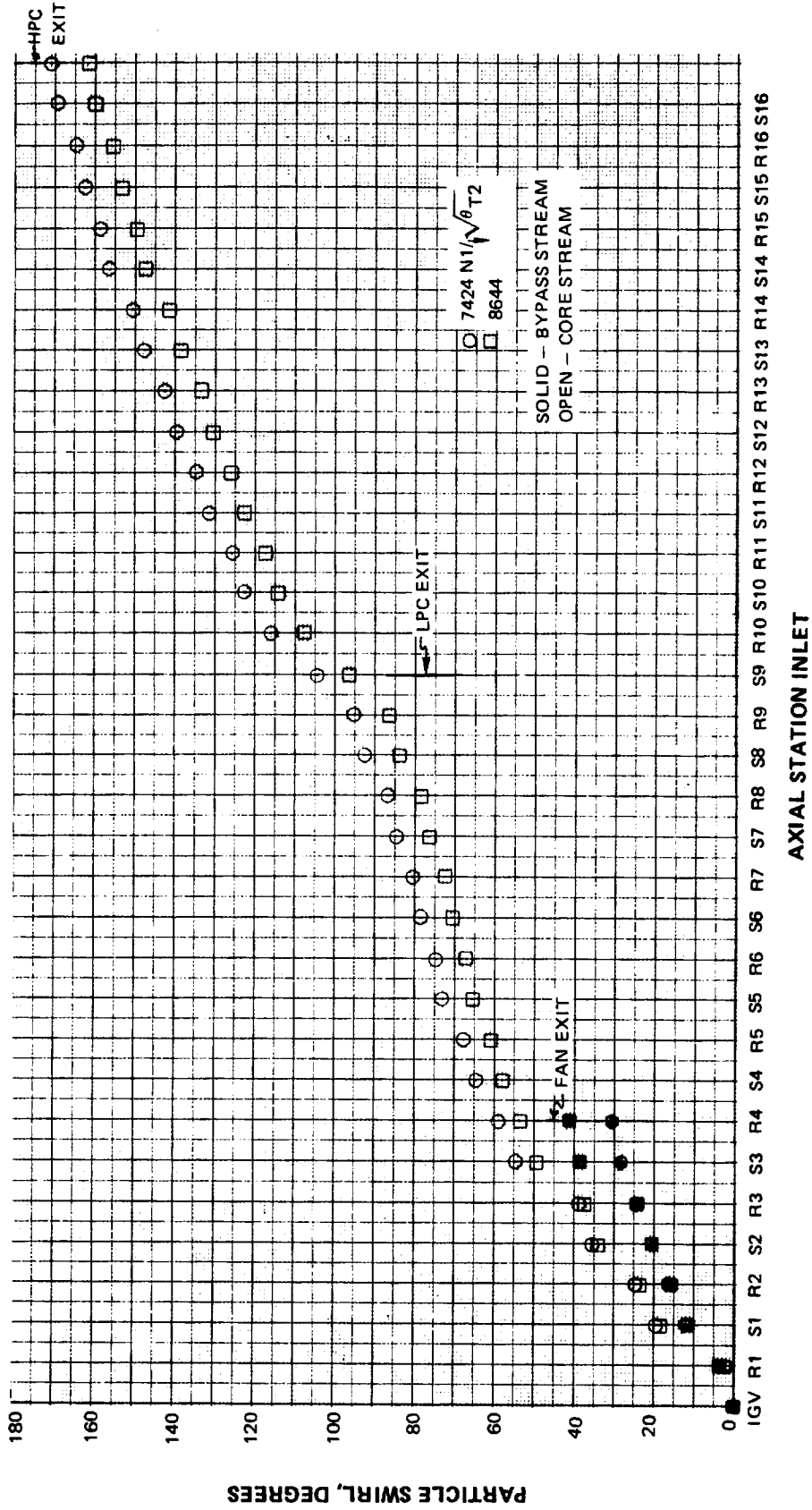

Figure 40 Predicted Particle Swirl (Particle Path) through Compressor System

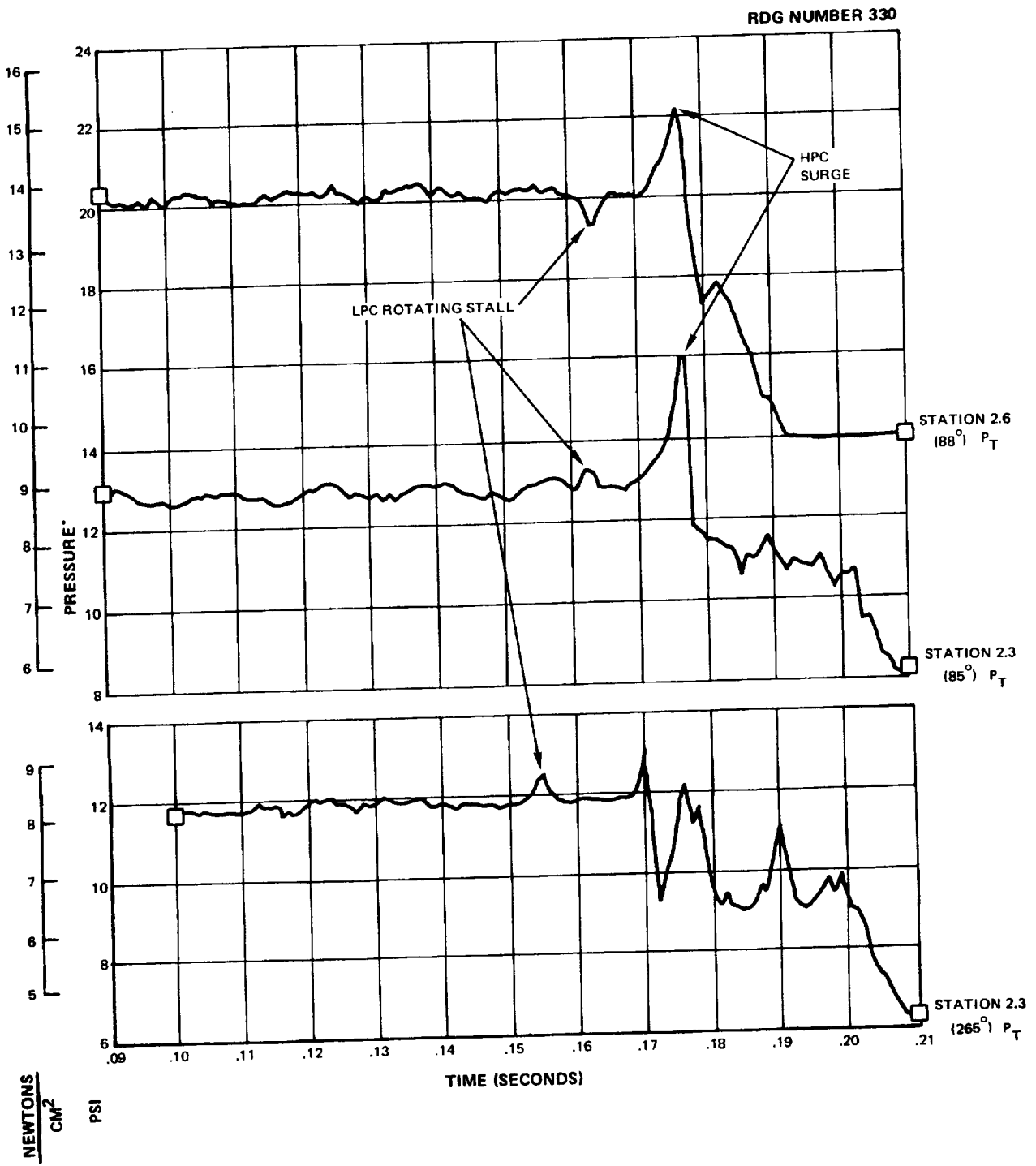

Figure 41 High Response Records at Stations 2.3 and 2.6 at 7300 rpm

ORIGINAL PHOTO COPY

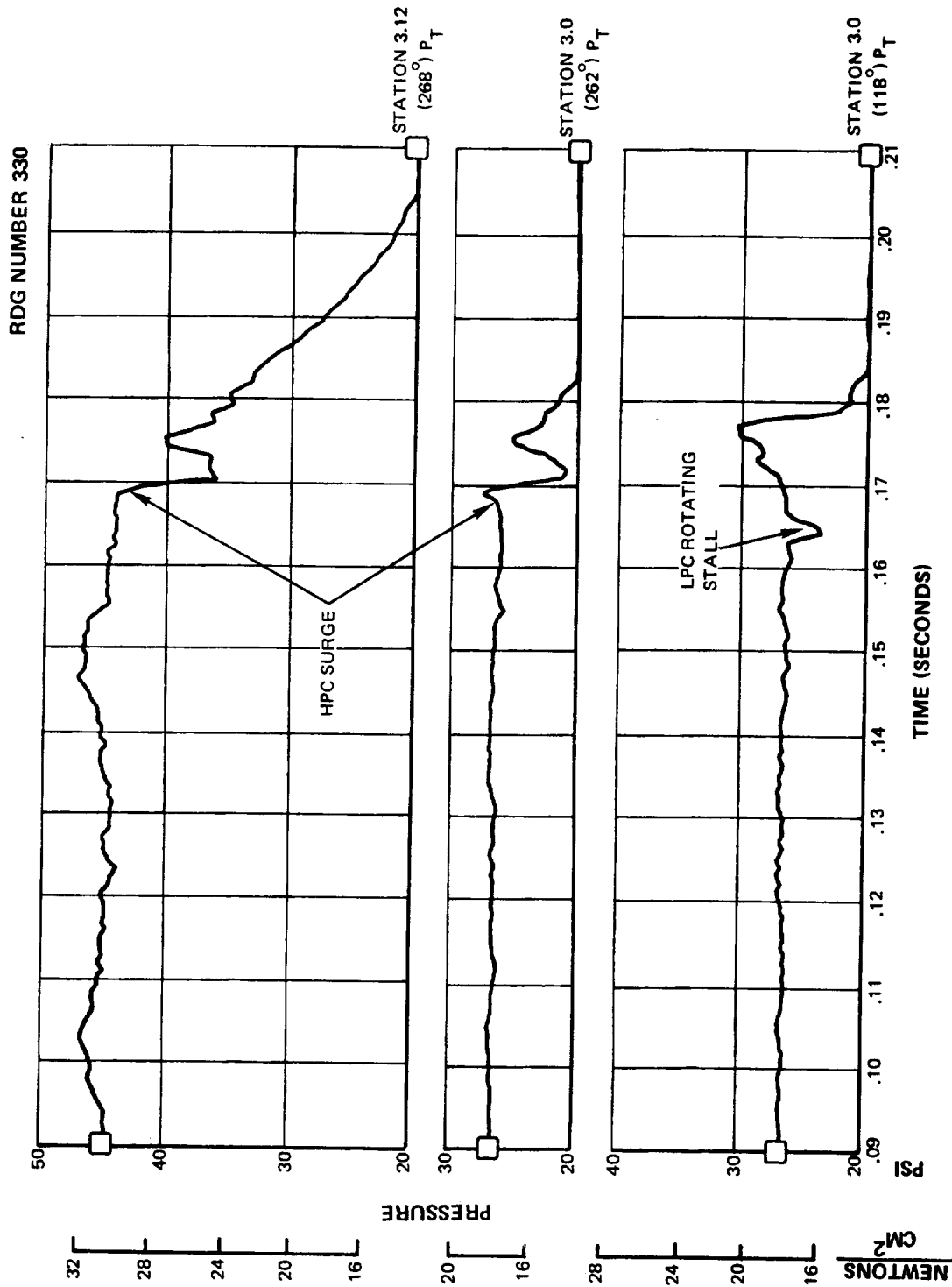

Figure 42 High Response Records at Stations 3.0 and 3.12 at 7300 rpm

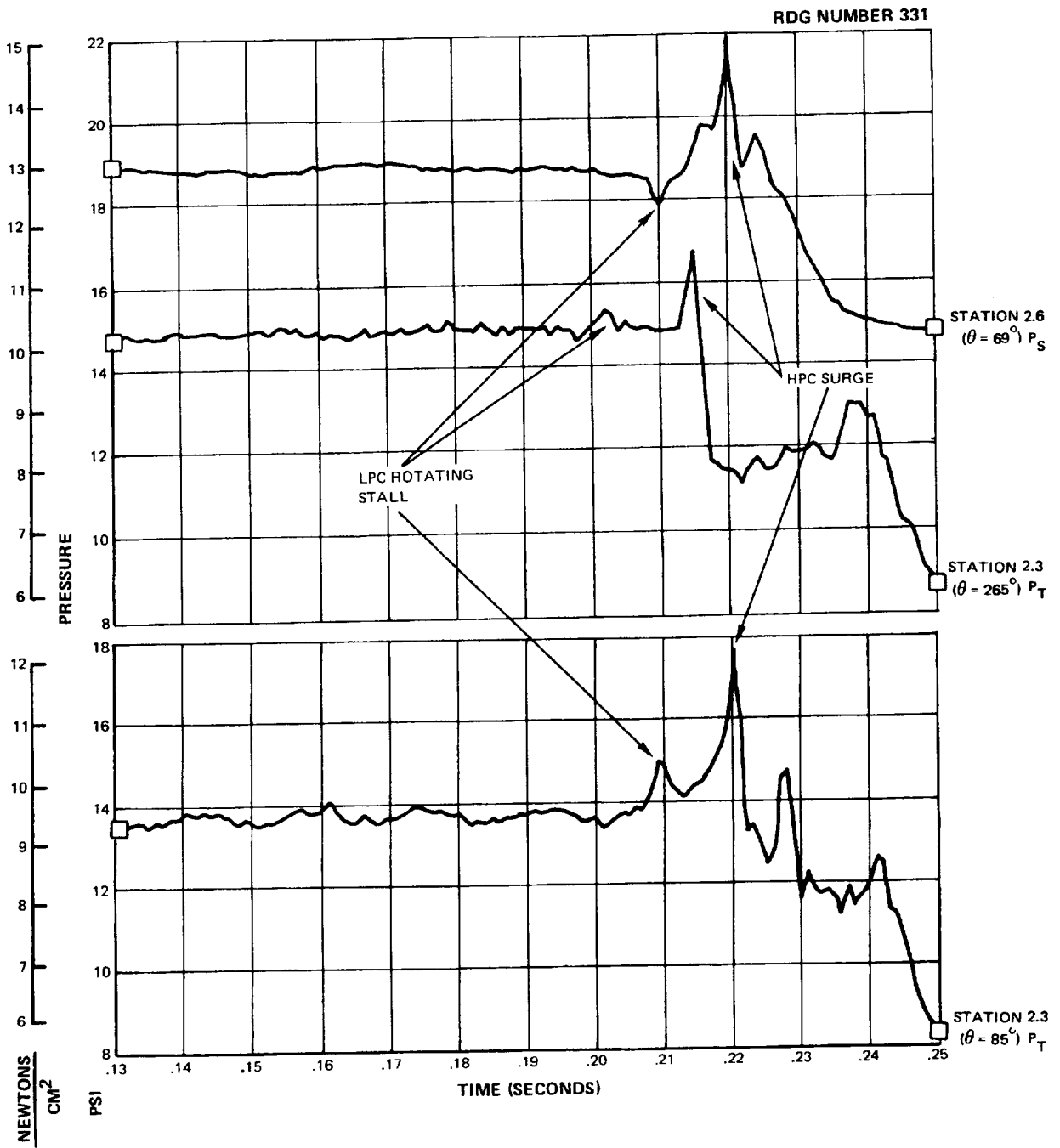

Figure 43 High Response Records at Stations 2.3 and 2.6 at 7900 rpm

RDG NUMBER 331

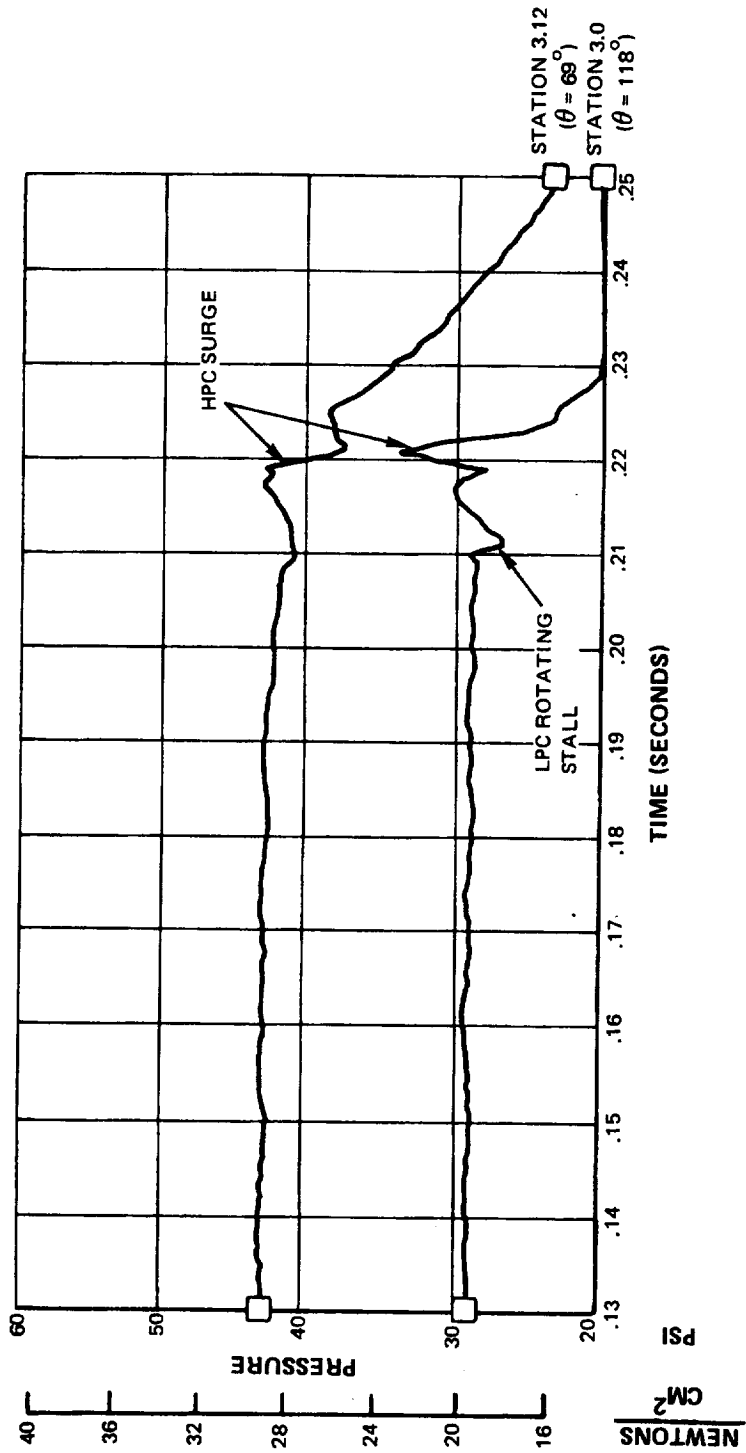

Figure 44 High Response Records at Stations 3.0 and 3.12 at 7900 rpm

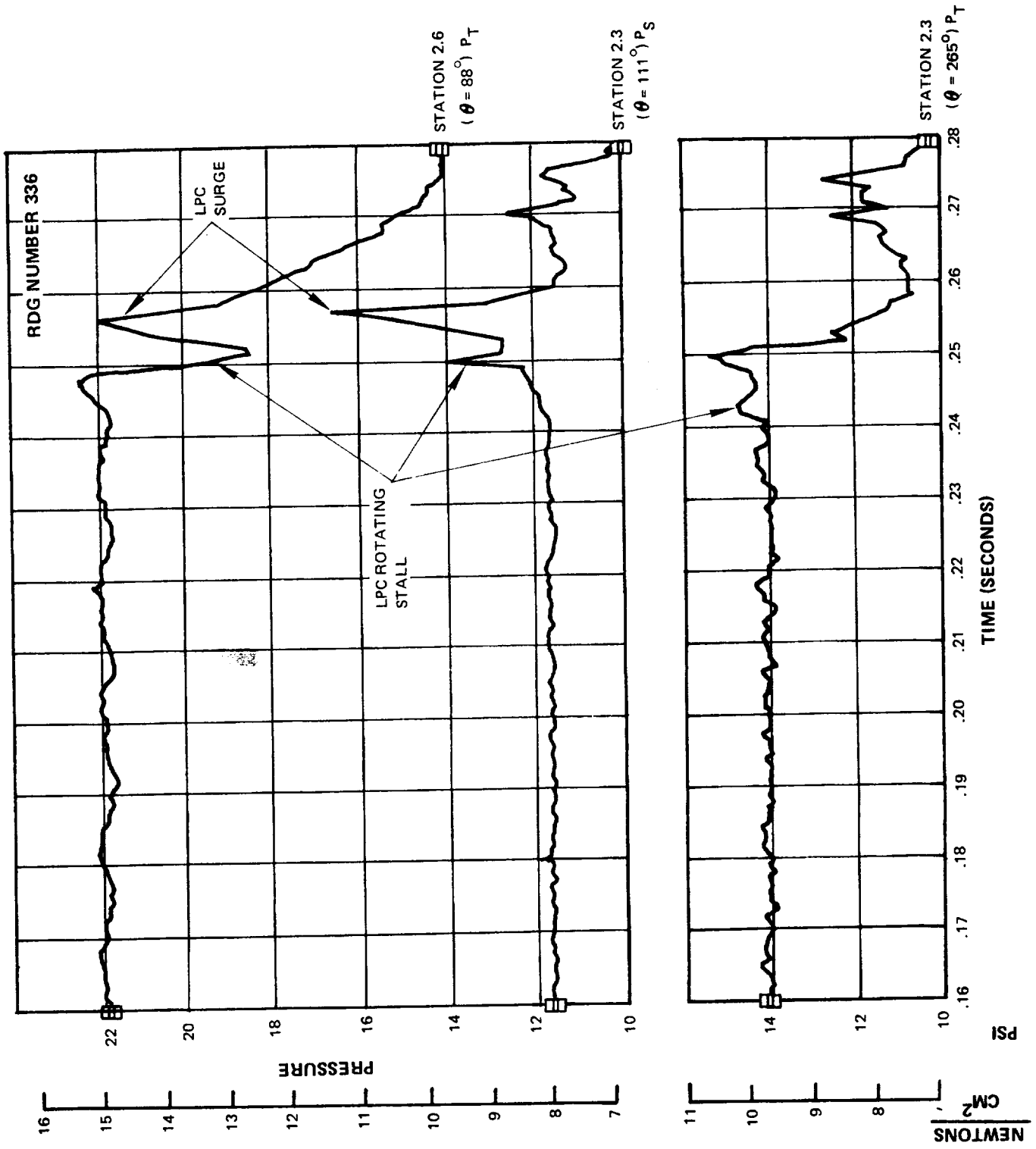

Figure 45 High Response Records at Stations 2.3 and 2.6 at 8200 rpm

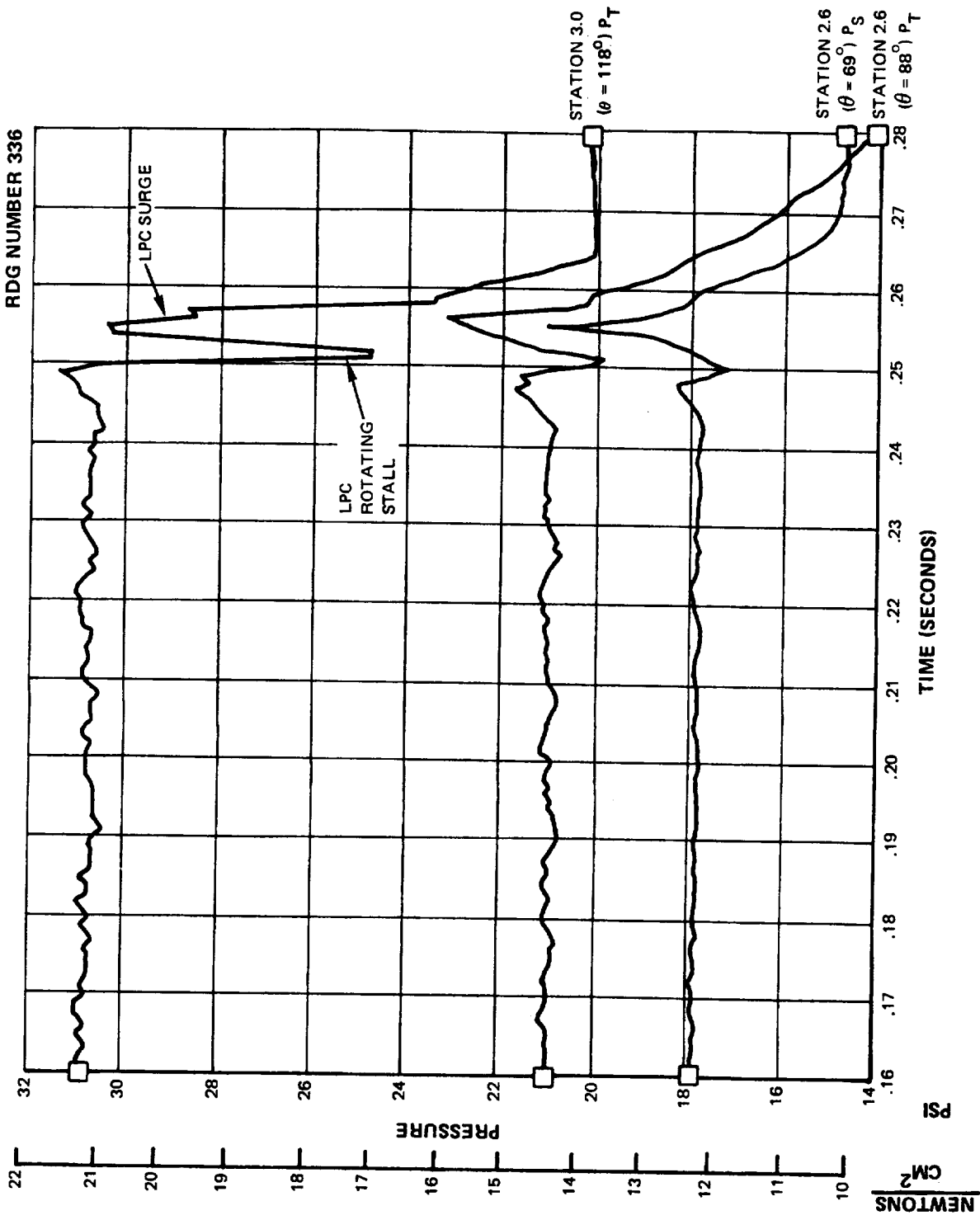

Figure 46 High Response Records at Stations 2.6 and 3.0 at 8200 rpm

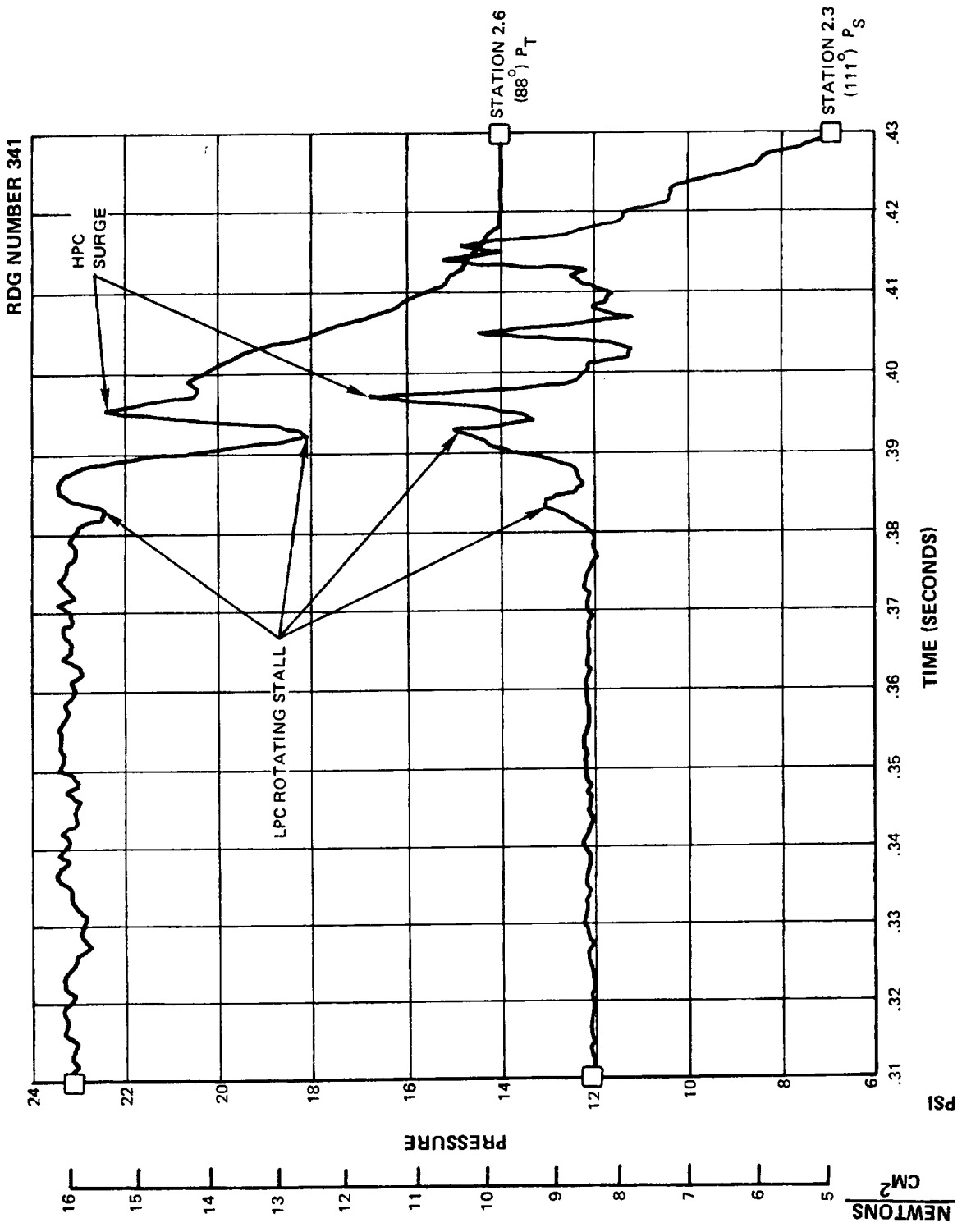

Figure 47 High Response Records at Stations 2.3 and 2.6 at 8700 rpm

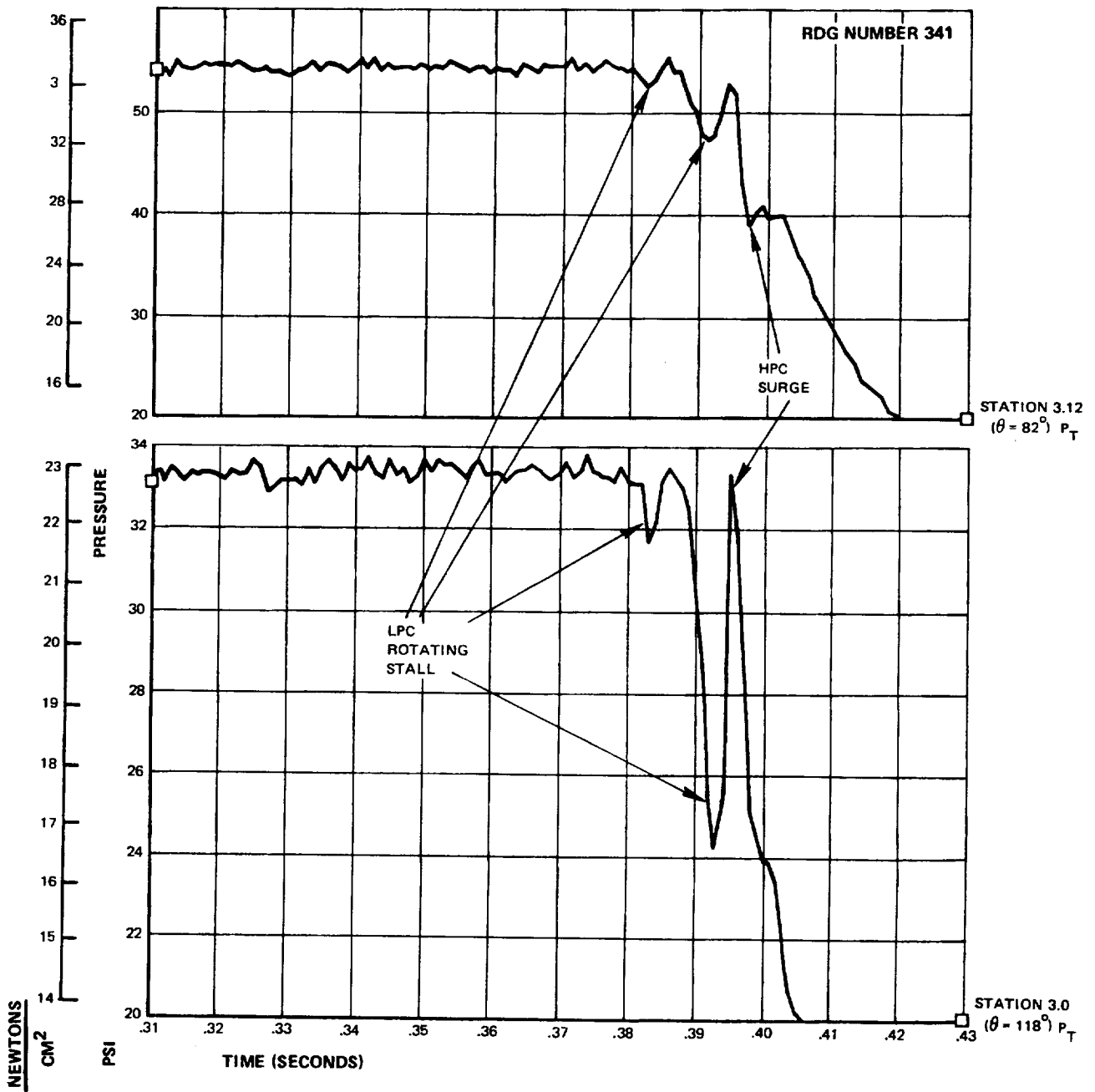

Figure 48 High Response Records at Stations 3.0 and 3.12 at 8700 rpm

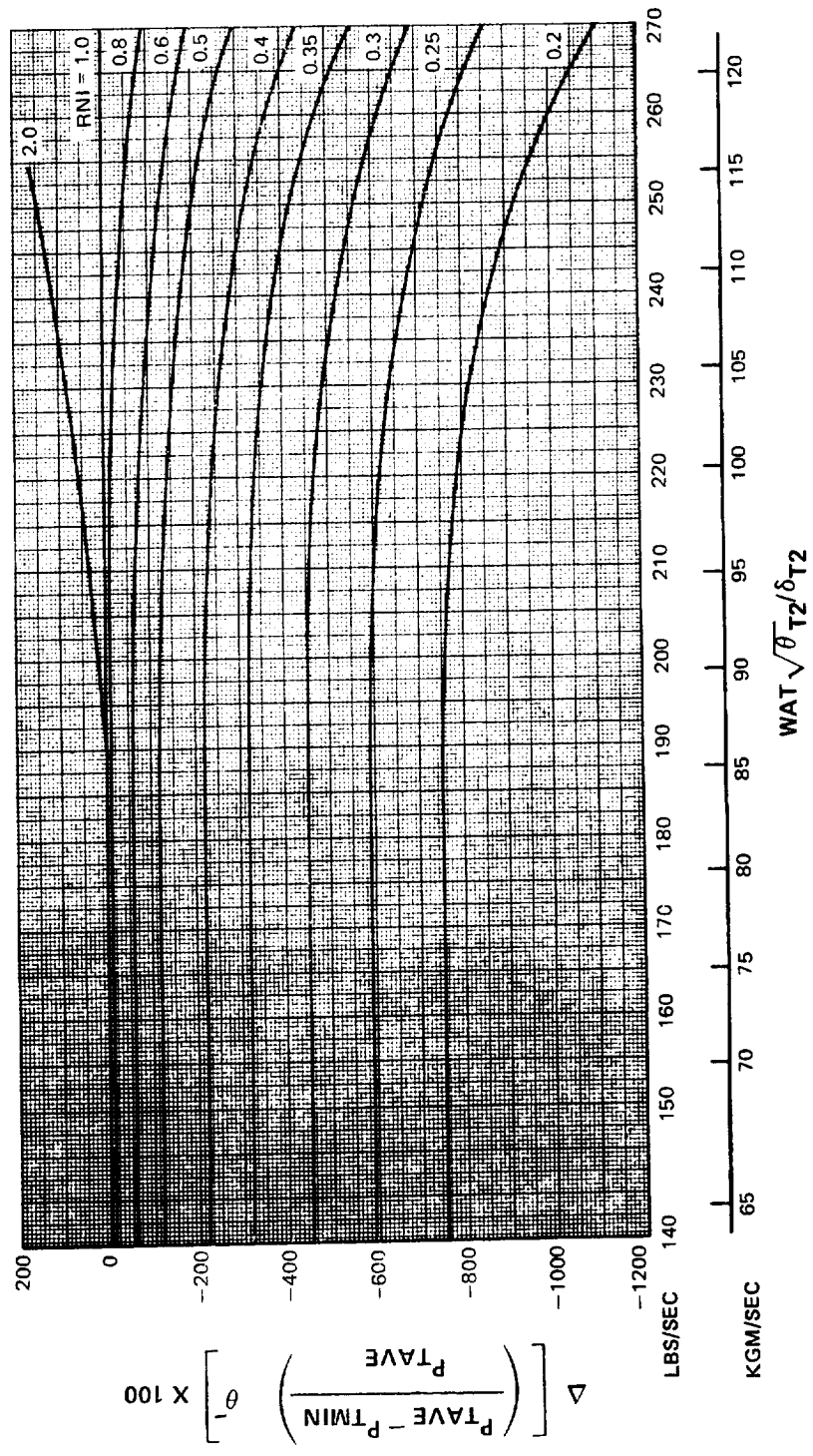

Figure 49 Effect of Reynolds Number on Distortion Levels to Stall

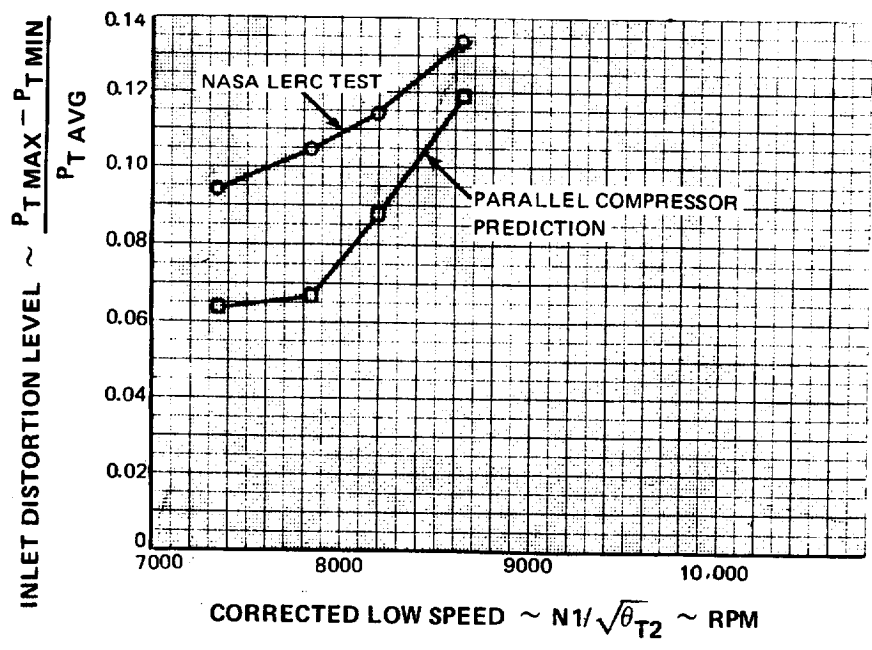

Figure 50 Distortion Levels to Stall

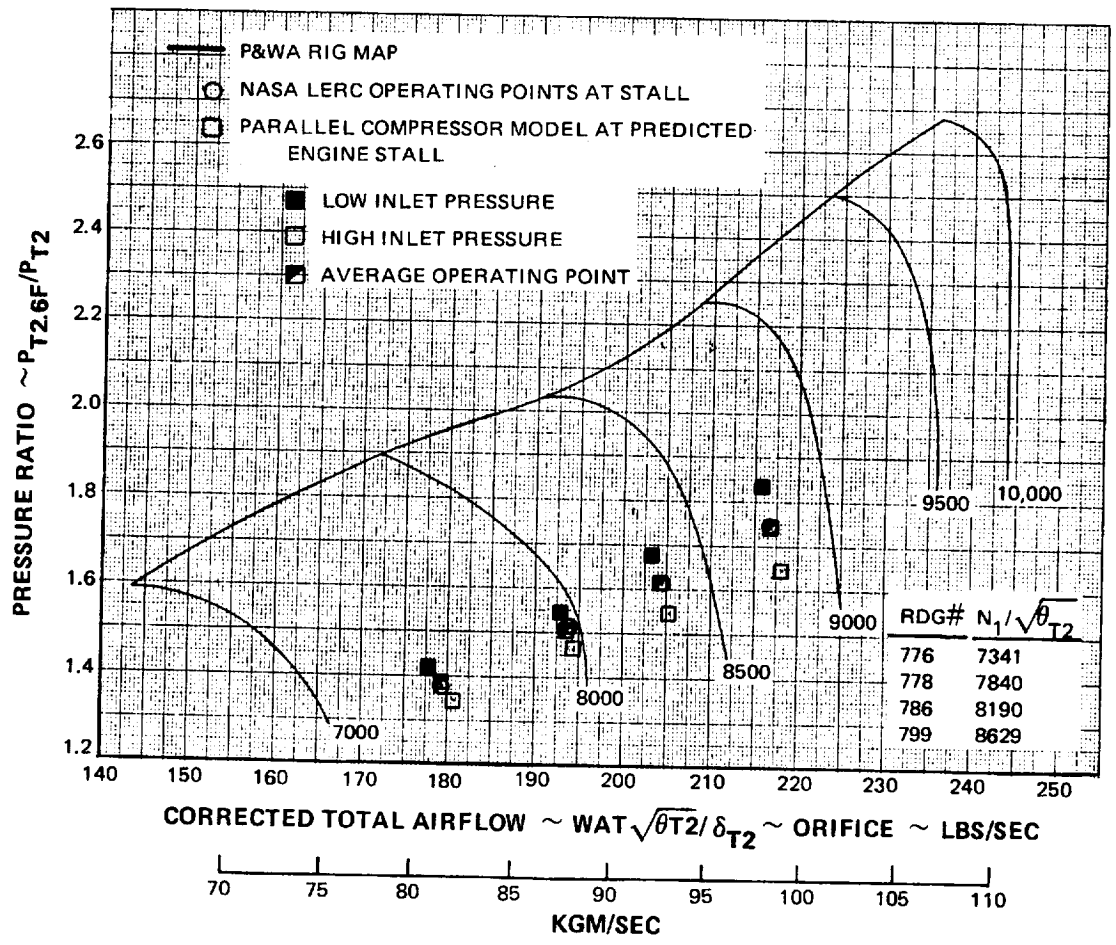

Figure 51 Comparison of Distorted Fan Performance at Engine Stall With Two-Segment Parallel Compressor Model

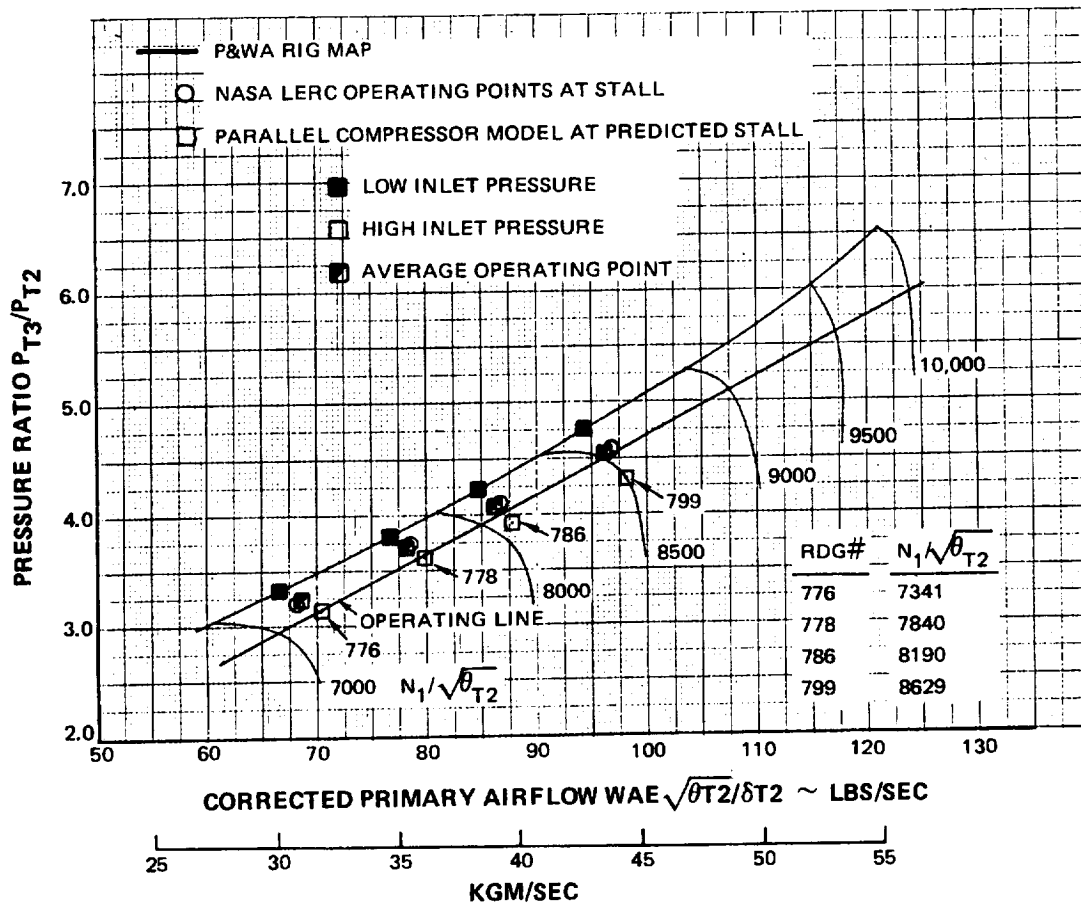

Figure 52 Comparison of Distorted LPC Performance at Stall With Two-Segment Parallel Compressor Model

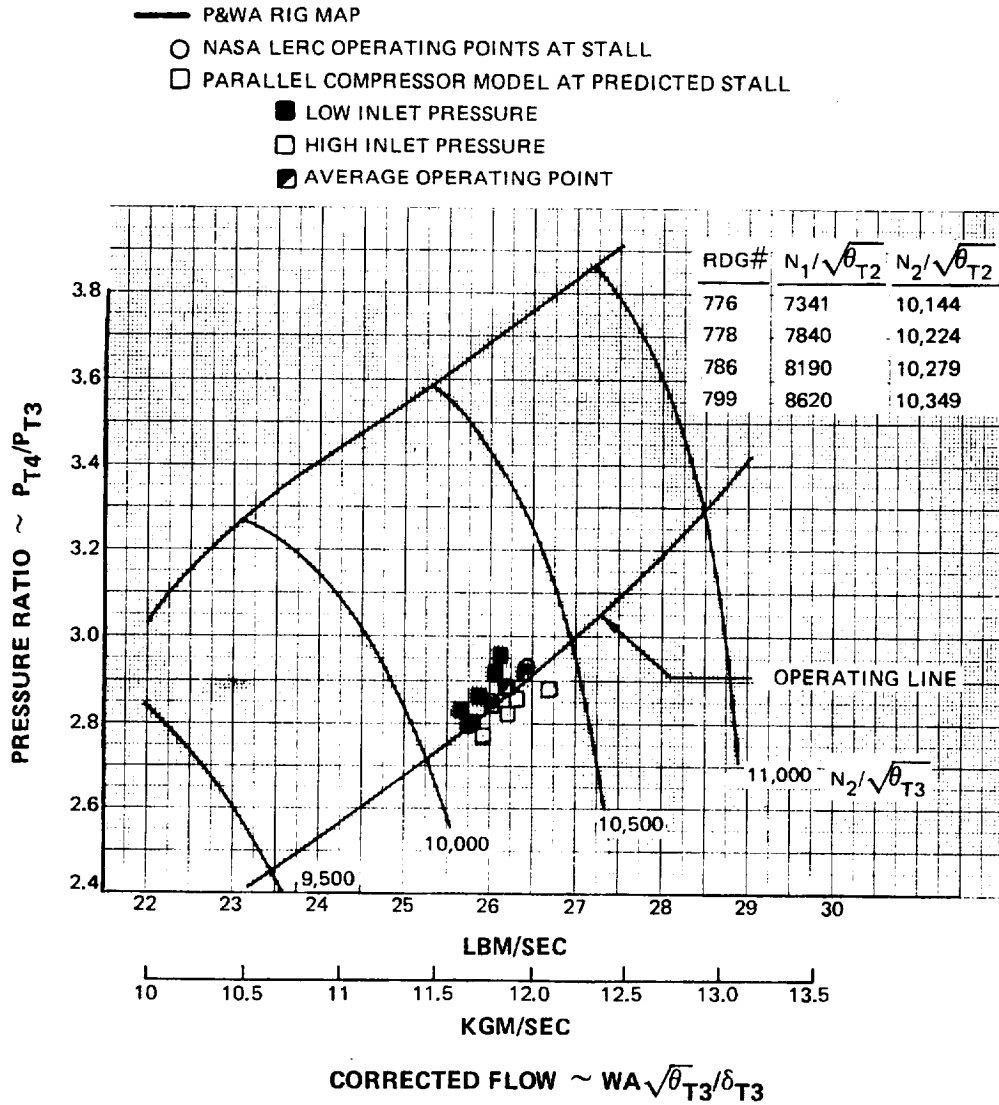

Figure 53 Comparison of Distorted HPC Performance at Engine Stall With Two-Segment Parallel Compressor Model

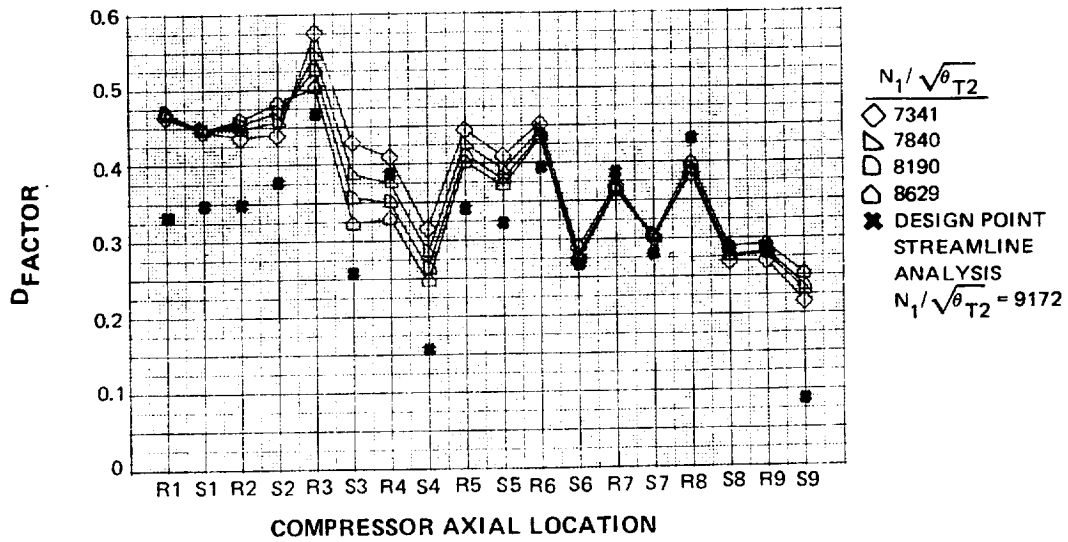

Figure 54 Distorted Inlet Diffusion Factors in Low Pressure Compressor

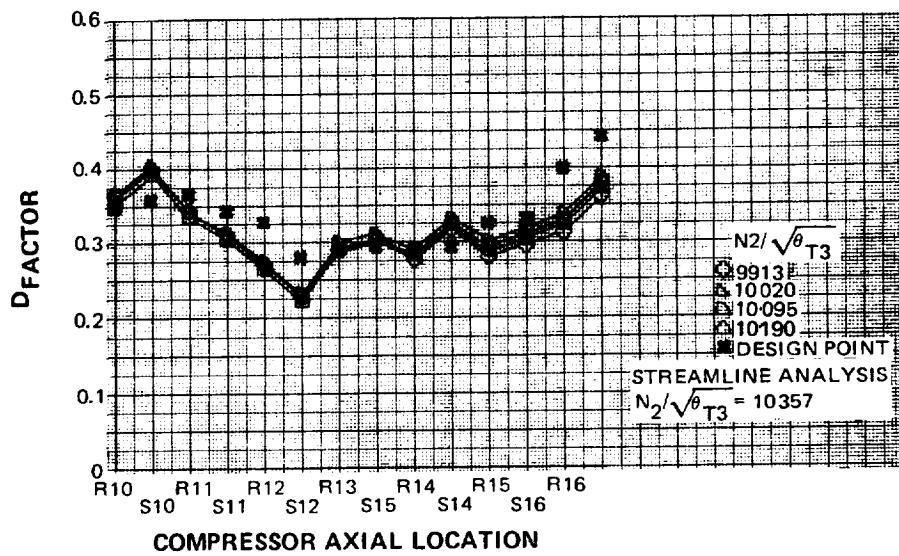

Figure 55 Distorted Inlet Diffusion Factors in High Speed Spool

APPENDIX A – CIRCUMFERENTIAL DISTORTION MODEL

Parallel Compressor Theory

Parallel compressor theory considers the circumference of the compressor to be divided into two flow regions: one of relatively low velocity such as would exist behind a distortion inducing screen and one of relatively high velocity. The essential points of parallel compressor theory are illustrated in Figure A-1. The compressor performance in each region is assumed to be that obtained from uniform flow operation at the local value of inlet velocity. It is further assumed that circumferential crossflow within the compressor is negligible and that the exit static pressure is uniform. The total pressure distortion is attenuated by the compressor because of the difference in pressure ratio between the high and low velocity regions. In addition, a temperature distortion is created out of phase (high temperature-low pressure) with the pressure distortion due to this attenuation. The limit of stability (stall point) of the distorted compressor is predicted to occur when the low velocity region reaches the uniform flow (undistorted) compressor stall point. The resultant performance at stall is calculated as the area average of the two regions.

Multiple Segment Parallel Compressor Model

The current model expands the basic parallel compressor theory by using multiple parallel segments to provide a detailed definition of the circumferential flow field. These segments pass through the compressor from inlet to exit. They do not, in general, enter and exit the compressor at the same relative circumferential location, but swirl to some degree commensurate with blade stagger angles, rotor rotation, and propagation characteristics of the flow properties assumed for the model and discussed in the following section. The flow rate in each segment is determined from its boundary conditions (inlet total pressure & total temperature and exit static pressure) and the compressor's performance within that segment in a manner quite similar to classic parallel compressor. The concept of using multiple parallel segments, however, is much more complex than the multiplication of the classic calculation. The complexity arises from two dimensional flow effects and from unsteady flow effects caused by the relative motion of rotor blades through the distorted flow region.

Consider a circumferential segment as it approaches the compressor. In the presence of a non-uniform inlet total pressure, circumferential static pressure gradients exist at the compressor inlet which redistribute the flow and can alter the flow velocity and direction of that segment. The performance of the first blade row will depend on the local flow angle as well as the local inlet flow rate within the segment. Proceeding through the compressor, the circumferentially non-uniform static pressure can cause further flow redistribution, particularly when "stagnant" air cavities exist external to the compressor flow path. This redistribution will result in a different amount of airflow in the segment at different axial locations within the compressor. When the segment encounters a rotor blade row, unsteady flow effects must be accounted for due to the circumferential nonuniformity of the flow field. The rotor performance depends not only on the local flow velocity and incidence but the time dependent (in the rotating reference) velocity and incidence gradients it experiences as it rotates past the segment.

Finally, the exit static pressure may not be uniform so it is necessary to know the angular displacement of the segment as it traverses the compressor in order to apply the proper downstream boundary condition. None of these effects are considered by basic parallel compressor theory but are all accounted for in the multiple segment model. The only restriction to the multiple segment approach is that the circumferential extent of the segment should span several blade passages. The flow properties in each segment are then representative of local average conditions. This restriction poses no problem as long as the distortion is large relative to the blade pitch or spacing, which, as previously stated, covers most cases of practical interest.

A further departure from parallel compressor theory is the use of individual blade row performance on the premise that deviations from uniform inlet performance will result in changes to the front-to-rear matching of the compressor blade rows. Such changes cannot be easily assessed on the basis of an overall performance representation. However, regardless of the way in which the uniform inlet performance is presented, the important point is to recognize the deviations from this performance that can occur under distorted flow conditions.

Procedurally, the multiple segment model calculation is similar to a classic two-segment parallel compressor solution. Each segment has known inlet and exit boundary conditions, and the mass flow rate consistent with these boundary conditions is to be determined. The major distinction is that the compressor segment performance is influenced by the distorted flow and is not identical to uniform flow performance as assumed by classic parallel compressor. In order to evaluate unsteady flow effects, the flow rates of adjacent segments are required in determining a given segment's performance. It is necessary, therefore, to establish a periodic solution around the circumference of the compressor. It is only after periodicity of mass flow rate is established that a calculation is considered complete. This is in contrast to the discontinuities in mass flow rate allowed by classic parallel compressor at the boundaries of the distorted region.

Calculation Procedure

Each segment has a constant circumferential extent with a fraction of the total mass flow entering the compressor. The fraction of the total mass flow in a given segment is dependent upon that particular segment's boundary conditions and the overall performance characteristic of the compressor for that segment. The performance characteristic effectively changes from segment to segment because of the various phenomena outlined in the previous section.

The inlet boundary condition for a segment is easily defined from the prescribed inlet total pressure and total temperature. The other boundary condition required is the static pressure at the exit of each segment. The average level of exit static pressure required to satisfy the specified total mass flow must be determined iteratively. Furthermore, the possibility of having non-uniform exit static pressure (Reference 1, for example) makes it necessary to know the proper circumferential location of each segment at the exit of the compressor.

Each segment moves circumferentially as it passes through the compressor since mean flow angles within the rotors, stators and gaps are seldom axial. In addition, the rotation of the rotor provides additional angular displacement. This is illustrated schematically in Figure A-2. Note that the segment displacement due to the rotor ($\Delta\theta$ segment) is less than that for a fluid particle ($\Delta\theta$ particle). This is because the acoustic path is important in establishing the non-steady flow in the rotating reference frame. Since an acoustical signal exceeds local fluid velocity in the forward direction, the "residence time" in the rotor is less than that for a fluid particle.

Angular Displacement = Residence Time x Angular Velocity

$$\Delta\theta_{\text{Segment}} = \left(\frac{b}{u + a} \right) \omega$$

or

$$\Delta\theta_{\text{Particle}} = \left(\frac{b}{u} \right) \omega$$

The angular displacement of each segment is calculated from local conditions and an average for all the segments is used to match proper inlet and exit boundary conditions. The average angular displacement of the segments is denoted as "flow swirl".

The compressor performance as well as the exit boundary conditions is therefore partially dependent upon the mass flow distribution. Consequently, an iteration scheme is utilized which necessarily assumes a mass flow distribution and solves for the mass flow in each segment on the basis of this assumption. The calculated mass flow distribution then replaces the original assumption and the procedure is repeated until the calculated mass flow distribution agrees with the assumed mass flow distribution. The necessity of knowing the mass flow distribution in order to calculate compressor performance will now be illustrated by a discussion of the various distorted flow phenomena incorporated in the multiple segment model.

Distortion Induced Inlet Flow Redistribution

Flow redistribution takes place upstream of a compressor operating with non-uniform flow as the compressor acts to create an upstream attenuation of the inlet flow distortion. A further description of this phenomenon may be found in Reference 2. The resultant inlet static pressure imbalance and a streamline curvature, Figure A-3, causes a variation in inlet air angle. With no inlet guide vane the incidence on the first rotor blade varies as in Figure A-4. The multiple segment model calculates this inlet angle variation in order to properly determine the first blade row performance.

The procedure for calculating the upstream flow redistribution is based on the use of a distribution of sources and sinks at the compressor inlet plane to represent the effect of the compressor on the upstream flow. As the fluid approaches the compressor, the axial velocity distribution is altered from the values far upstream of the compressor. In some regions around the circumference the fluid velocity is decreased as it gets closer to the compressor so that a flow source opposing this fluid may be thought to exist. Similarly, a flow sink would account for an increase in the velocity of the fluid as it approaches the compressor. The strengths of these sources and sinks are calculated in the following manner.

The upstream velocity distortion is separated into its rotational and irrotational components, both of which are considered to have amplitudes such that a linearized description can be adapted. The rotational component is associated with the inlet total pressure distortion. Since the total pressure is convected by the flow from far upstream to the compressor, the rotational velocity distortion can be evaluated far upstream ($-\infty$) where the irrotational component is zero.

$$\delta C_{x_{ROT}} = \delta C_{x_{-\infty}} = \frac{1}{\rho \bar{C}_x} \frac{\delta P_{0_{-\infty}}}{\left(1 + \frac{\gamma-1}{2} \bar{M}^2\right)^{\frac{\gamma}{\gamma-1}}} \quad (\delta P_{s_{-\infty}} = 0)$$

The irrotational part of the velocity distortion is due to the upstream flow redistribution induced by the compressor. Since there are multiple segments, the compressor can be represented by an array of sources and sinks located at the compressor inlet plane with the effect of compressibility accounted for by using a Prandtl-Glauert transformation. The local strength of the source (sink) is calculated from the irrotational component of axial velocity at the inlet.

$$\delta C_{x_{IRROT}} = \delta C_{x_{INLET}} - \delta C_{x_{ROT}}$$

The inlet velocity distortion, $\delta C_{x_{inlet}}$, is a function of the compressor performance and local boundary conditions for each segment and is determined iteratively. The source (sink) strengths determined from $\delta C_{x_{irrot}}$ can be used in a formulation from Reference 3 to determine the velocity potential function for such an array. The tangential velocity perturbation component can then be determined from this potential function. It should be noted that although the analysis has been derived on the basis of small perturbations, comparison with measured data shows that the calculation has provided an accurate solution for the inlet air angle distribution even when the imposed inlet total pressure distortion was quite large (see Figure 14).

Circumferential Crossflow

Circumferential flow redistribution can also occur within the compressor as well as upstream of it. Within the compressor, this flow redistribution can take two different forms as illustrated by Figure A-5. First of all, the compressor flowpath has axial gaps between blade

rows which provide a means for redistributing the flow. This occurs primarily near the edges of the distorted region where static pressure gradients are largest. Since it is localized to the edges and since normal axial spacing in a modern engine is small, this form of cross-flow can normally be considered negligible, and is not included in this analysis.

The second form of cross flow can take place within cavities (roots of shrouded stators and bleed plenums) which are exposed to the circumferential pressure gradient. Since the static pressure differences can be large and the fluid within a cavity has negligible axial momentum, the crossflow can be significant. This was demonstrated qualitatively by a flow visualization experiment on a 3 stage compressor with inlet distortion, the results of which are shown in Figure A-6. In this experiment, felt tufts were mounted in an annular plenum external to the compressor flowpath. The tufts were viewed through a plexiglass cover and indicated substantial circumferential flow velocities consistent with the imposed pressure distortion.

The calculation procedure in the current model consists of an evaluation of mass flow transfer between each segment and the external flow cavity. The flowpath circumferential static pressure distribution is assumed to be known but the cavity pressure distribution must be determined iteratively. Since the crossflow occurs as a steady flow process there can be no mass accumulation within the cavity. Therefore, the solution for the static pressure distribution within the cavity must satisfy a continuity balance. The calculation depends upon the flow characteristics of the cavities as well as those of the passages connecting the cavities with the flowpath. Large cavities induce the most crossflow and for these the flow characteristics of the connecting passages are more significant than the cavity flow characteristics for determining crossflow rate.

In general, exact flow characteristics for these connecting passages are not available. The model makes use of a general correlation of flow coefficients for air being bled off perpendicular to the flow direction. This correlation was empirically derived in Reference 4 and is reproduced on Figure A-7. Because of the general nature of this correlation, the results of the current model are only approximate. However, the usual amplitude of crossflow within any single cavity is only a small percentage of the total airflow. The use of generalized flow coefficients is normally adequate.

The sequence of the iteration starts with a single segment (one having a relatively high flowpath static pressure is selected) by assuming the local static pressure within the cavity. Flow characteristics for the passage connecting the flowpath with the cavity are used to determine the mass transfer into the cavity. These characteristics depend upon the static pressure difference across the connecting passage, the cross-sectional area of the passage, and flow conditions (static pressure, total temperature, Mach number) on the high pressure end of the passage. The mass flow which enters from the first segment into the cavity is used to calculate the Mach number in the cavity, based upon the cavity geometry. Proceeding in the direction of rotor rotation to the next segment, a change in total pressure occurs due to the friction or drag of the cavity walls. These walls may be either stationary or rotating and the frictional losses depend on the relative flow velocities. The mass transfer calculation is repeated at the next segment based upon the local flow parameters. The mass flow rate within the cavity and

the flowpath are appropriately adjusted and the calculation is continued until a full circuit around the circumference is completed. A check is then made for continuity of mass flow into and out of the cavity. If continuity of mass is satisfied within a preset tolerance the solution is accepted. If not, the calculation is repeated using a higher or lower guess for cavity pressure depending upon whether the net cumulative mass flow into the cavity is positive or negative. The iteration is continued until a solution (zero net mass flow into the cavity) is obtained.

Unsteady Flow Effects

Another reason why distorted performance differs from uniform inlet values is because the rotor experiences time variant changes in velocity and incidence as it moves through the distorted flow field. First of all, the acceleration of fluid through the rotor implies a local static pressure difference between the leading and trailing edges over and above that indicated by the quasi-steady pressure rise characteristic. This additional pressure rise must be accounted for in determining the distorted compressor performance.

In order to simply illustrate the basic fluid mechanics of this unsteady static pressure change across the blade row, the blade passage can be modeled in the rotating reference frame as a one-dimensional, inviscid, linear diffuser with unsteady flow.

For this one-dimensional inviscid diffuser, it will be assumed that area varies linearly from inlet to exit as illustrated in the figure below. The unsteady pressure change can be determined from application of the Momentum Equation.

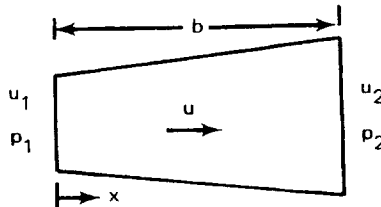

$$-\frac{1}{\rho} \frac{\partial p}{\partial x} = u \frac{\partial u}{\partial x} + \frac{\partial u}{\partial t}$$

$$-\int_0^b \frac{\partial p}{\partial x} dx = \int_0^b \rho u \frac{\partial u}{\partial x} dx + \int_0^b \rho \frac{\partial u}{\partial t} dx \quad (1)$$

The first term on the right is the quasi-steady state pressure rise due to diffusion and is considered to be the static pressure rise across the blade row with uniform, time invariant inlet conditions. This term is evaluated like an actuator disk for the circumferentially local mass flow rate and combined with the second term which represents the effect of local acceleration of the fluid within the blade passage. For simplicity, this term will now be evaluated for the

case of an incompressible fluid in order to indicate the controlling parameters. The effects of compressibility have been determined separately and are included in the computer model in an approximate manner. The circumferential displacement of the segment by the rotor provides for the proper acoustic delay of the static pressure rise.

Assumptions:

$$u_1 = \bar{u}_1 + u_1'$$

$$\frac{\partial u_1}{\partial t} = \frac{\partial u_1'}{\partial t}$$

$$u(x) = u_1 \frac{A_1}{A(x)}$$

$$A(x) = A_1 + \frac{A_2 - A_1}{b} x$$

Substituting into Equation 1

$$\int_0^b \rho \frac{\partial u}{\partial t} dx = \rho \int_0^b \frac{\partial u_1'}{\partial t} \frac{1}{1 + \frac{A_2 - A_1}{A_1 b} x} dx \quad (2)$$

$$\int_0^b \rho \frac{\partial u}{\partial t} dx = \rho \frac{\partial u_1'}{\partial t} \underbrace{\frac{A_1 b}{A_2 - A_1} \ln \frac{A_2}{A_1}}_l$$

$$p_2 - p_1 = \int_0^b \rho u \frac{\partial u}{\partial x} dx - \rho l \frac{\partial u_1'}{\partial t} \quad (3)$$

The unsteady part of the pressure rise is thus proportional to the rotor chord length and the change of relative inlet velocity. This acceleration rate can be determined from the fixed coordinate system velocity distortion and the rotational speed of the rotor.

In order to calculate the change in stagnation temperature due to this unsteadiness, the following relation between fluid properties, which may be derived from the First Law of Thermodynamics, is applicable:

$$T ds = dh - \frac{1}{\rho} dp \quad (4)$$

$$h_0 = h + \frac{u^2}{2}$$

$$\therefore dh_0 = dh + u du$$

$$T ds = dh_0 - u du - \frac{1}{\rho} dp$$

Integrating across the diffuser:

$$\int_0^b T \frac{\partial s}{\partial x} dx = \int_0^b \left(\frac{\partial h_0}{\partial x} - u \frac{\partial u}{\partial x} - \frac{1}{\rho} \frac{\partial p}{\partial x} \right) dx \quad (5)$$

From Momentum Equation:

$$-\frac{1}{\rho} \frac{\partial p}{\partial x} = \frac{\partial u}{\partial t} + u \frac{\partial u}{\partial x}$$

$$\int_0^b \frac{\partial h_0}{\partial x} dx = -\int_0^b \frac{\partial u}{\partial t} dx + \int_0^b T \frac{\partial s}{\partial x} dx \quad (6)$$

Thus, the change in stagnation enthalpy relative to the rotor is composed of two terms. The first term corresponds to the unsteady pressure rise and will be treated by making the same assumptions concerning compressibility.

$$\int_0^b \frac{\partial u}{\partial t} dx = \mathcal{L} \frac{\partial u_1'}{\partial t}$$

$$T_{02} - T_{01} = -\frac{1}{C_p} \mathcal{L} \frac{\partial u_1'}{\partial t} + \frac{1}{C_p} \int_0^b T \frac{\partial s}{\partial x} dx \quad (7)$$

This unsteady total temperature rise is added to the steady rotor temperature rise as determined from uniform inlet flow conditions. The steady and unsteady total temperature rises are combined in a manner similar to the static pressure rise. Like the unsteady pressure rise, the unsteady temperature rise is proportional to the rotor chord length and the time rate of change of velocity relative to the rotor. Even though the analysis is an inviscid one, the second term is generally non-zero because of the entropy gradients associated with the upstream total pressure (or temperature) distortion. In order to properly account for the entropy gradients, it is necessary to know the path line followed by fluid particles through the compressor. The second term is evaluated for each segment using the difference between

the circumferential displacement of a fluid particle and the circumferential displacement of the segment to define the amplitude of the entropy gradient. The temperature change so determined is then added to the steady and unsteady temperature change for each segment.

Fluid Particle Displacement Effects

It is necessary to calculate the fluid particle displacement because the particles within a rotor blade passage can swirl into and out of the distorted flow region. When viewed from a fixed reference frame, the entropy of the fluid entering a rotor passage may be different from that of the fluid leaving that same passage at that instant in time as shown in Figure A-8. This difference in entropy must be accounted for in calculating the changes in the temperature across the blade passage, as can be seen from Equation 7.

Since the flow process across the blade row was considered inviscid in this analysis, any entropy change across the blade row must be due to a difference in instantaneous inlet and exit fluid properties. This difference becomes evident when it is realized that fluid particles are displaced circumferentially by the rotor and that the fluid within the blade passage at any time originated from a circumferential sector of finite extent. The extent of this sector is a function of the rotational speed, the rotor chord length and the relative fluid velocity. The properties of the fluid leaving the rotor passage originated at the beginning of this sector while the entering fluid comes from the end of the sector. Thus, the entropy change across the rotor is equal to the circumferential entropy difference across the sector, which is easily defined from the imposed rotor inlet total pressure and total temperature distortion and the sector extent. The displacement of the fluid by each rotor blade row is calculated and accumulated in the multiple segment parallel compressor model in order to provide an accurate exit total temperature distortion profile.

This effect on total temperature due to particle displacement accounts for the observation often made with multistage compressors that the exit total temperature distortion is not aligned with the attenuated total pressure distortion as predicted by parallel compressor theory. This is illustrated in Figure A-9 where the exit total temperature distortion has been calculated from measured attenuation of an imposed inlet total pressure distortion. The agreement with data is greatly improved by accounting for particle displacement when calculating the temperature distortion.

The impact of particle swirl on distorted compressor stage matching is illustrated in Figure A-10. As shown in the figure for parallel compressor, the low total pressure region and high total temperature region are aligned throughout the compressor. Note that in this particular example no circumferential displacement (flow swirl) of the distorted region is assumed. When particle swirl is taken into account, however, there is a region of relatively low total temperature in the rear stages of the low total pressure region. This results in lower corrected flow and higher corrected speed in these stages relative to conditions that would normally be obtained with a uniform inlet and the same inlet values of corrected flow and speed. There is thus a tendency to increase incidence in the rear stages which effects a re-match of the front-to-rear loading distribution of the compressor stages. A similar rematch in the reverse direction occurs in the undistorted region of the compressor. The net effect

of the rematch is to reduce the circumferential variation in velocity at the front and increase the velocity variation at the rear of the compressor relative to that calculated from parallel compressor theory. The consequences of particle swirl with respect to the distorted stall line are therefore dependent on the axial location of the limiting stage.

REFERENCES

1. "Compressor-Diffuser Interaction with Circumferential Flow Distortion", by E. Greitzer and H. Griswold, Project SQUID Workshop Proceedings, July, 1974.
2. "Attenuation of Circumferential Inlet Distortion in Multistage Compressors", by G. Plourde and A. Stenning, AIAA Paper (67-415, August, 1967).
3. "Hydrodynamics" by Sir Horace Lamb, Dover Publications, 1945, (pp. 51, 71).
4. "A Study of Perforation Configurations for Supersonic Diffusers", G. McLafferty, UARL Report R-53372-7, December, 1950.

LIST OF SYMBOLS

A	Area
a	Sonic Velocity
b	Chord Length
C _p	Specific Heat at Constant Pressure
h	Enthalpy
N1	Low Rotor Speed
N2	High Rotor Speed
p, P	Pressure
s	Entropy
T	Temperature
t	Time
u, U	Velocity
α, β	Air Angle
δ	Perturbation Quantity
θ _{T2}	Inlet Corrected Temperature
θ _{T3}	HPC Inlet Corrected Temperature
ρ	Density
τ	Empirical Time Constant
ω	Circular Frequency

SUBSCRIPTS

o, T	Total Conditions
INLET, 1	Inlet
2	Exit
-∞	Upstream Infinity
x	Axial Direction
Q.S.	Quasi-steady Value

SUPERSCRIPTS

—	Average
/	Perturbation Quantity

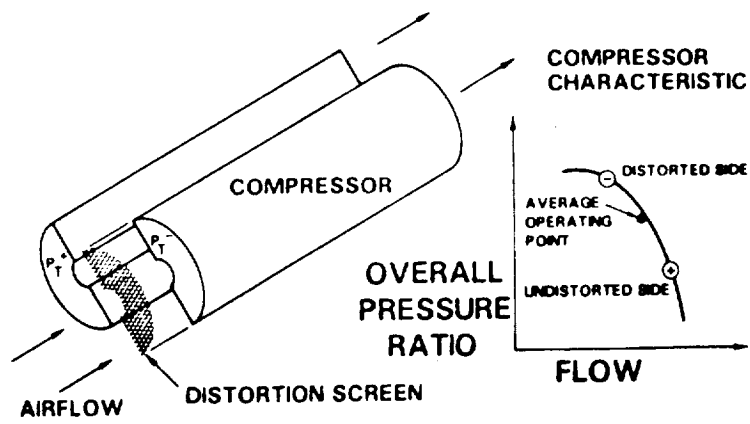

Figure A-1 Parallel Compressor Distortion Analysis

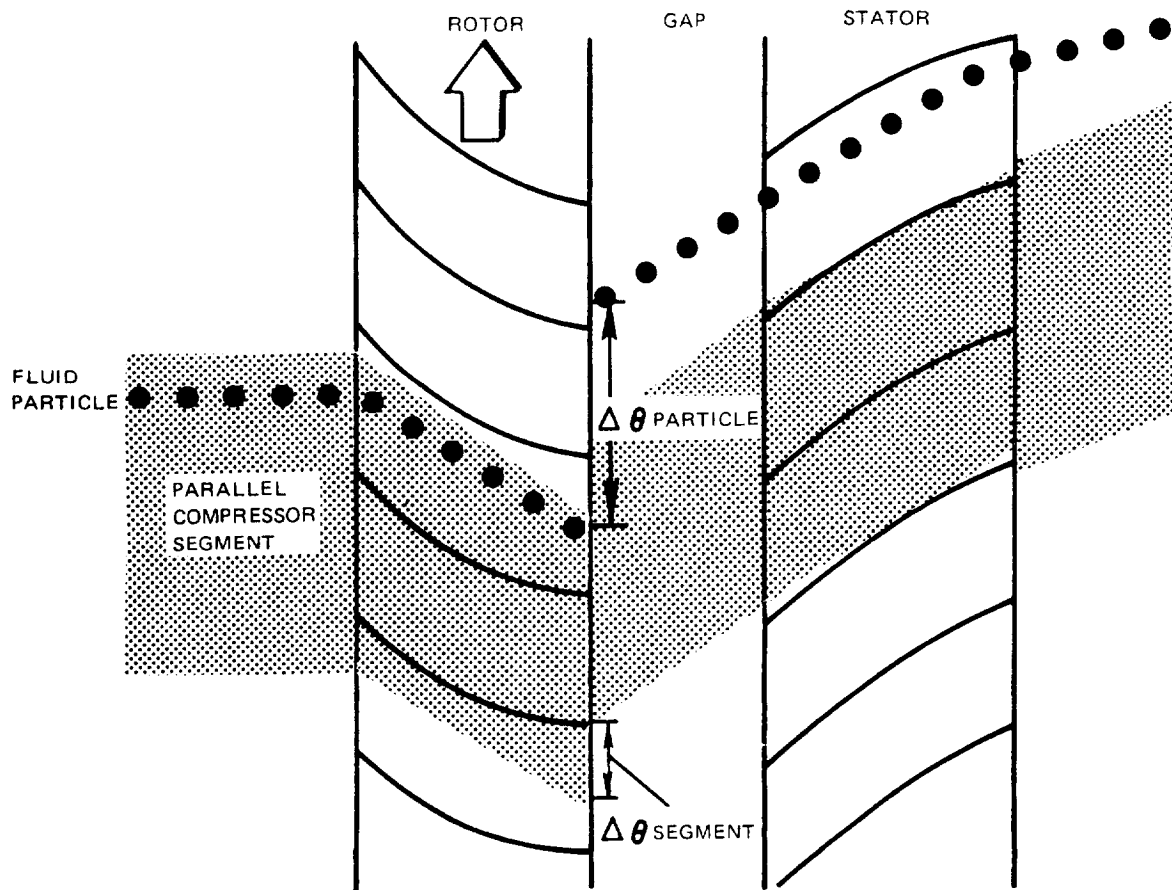

Figure A-2 Segment (Flow) and Particle Swirl Through A Compressor

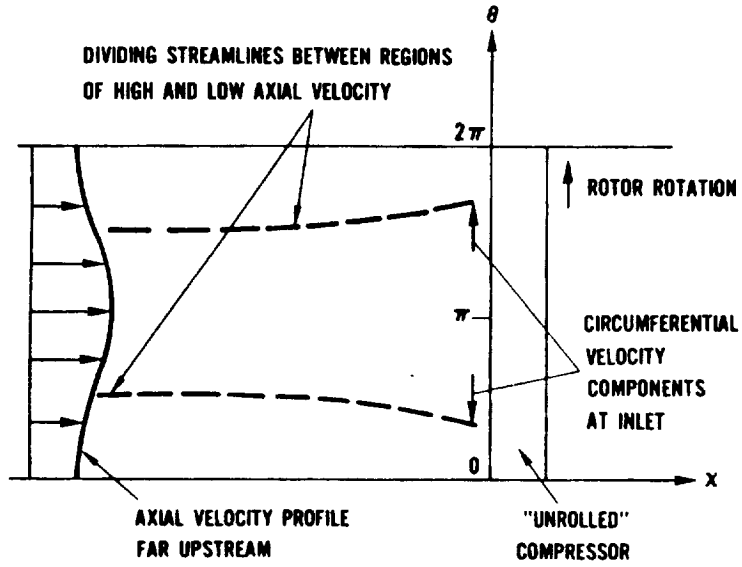

Figure A-3 Asymmetric Flowfield Upstream of Compressor

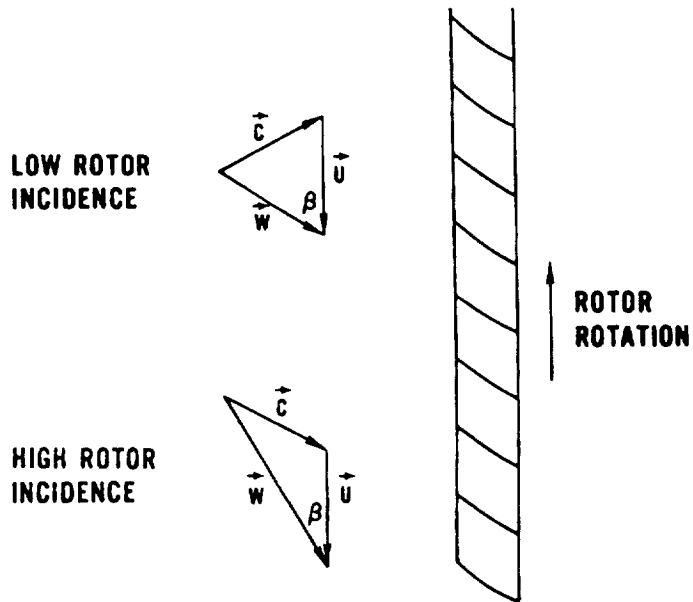

Figure A-4 Effect of Upstream Circumferential Velocity on Rotor Incidence

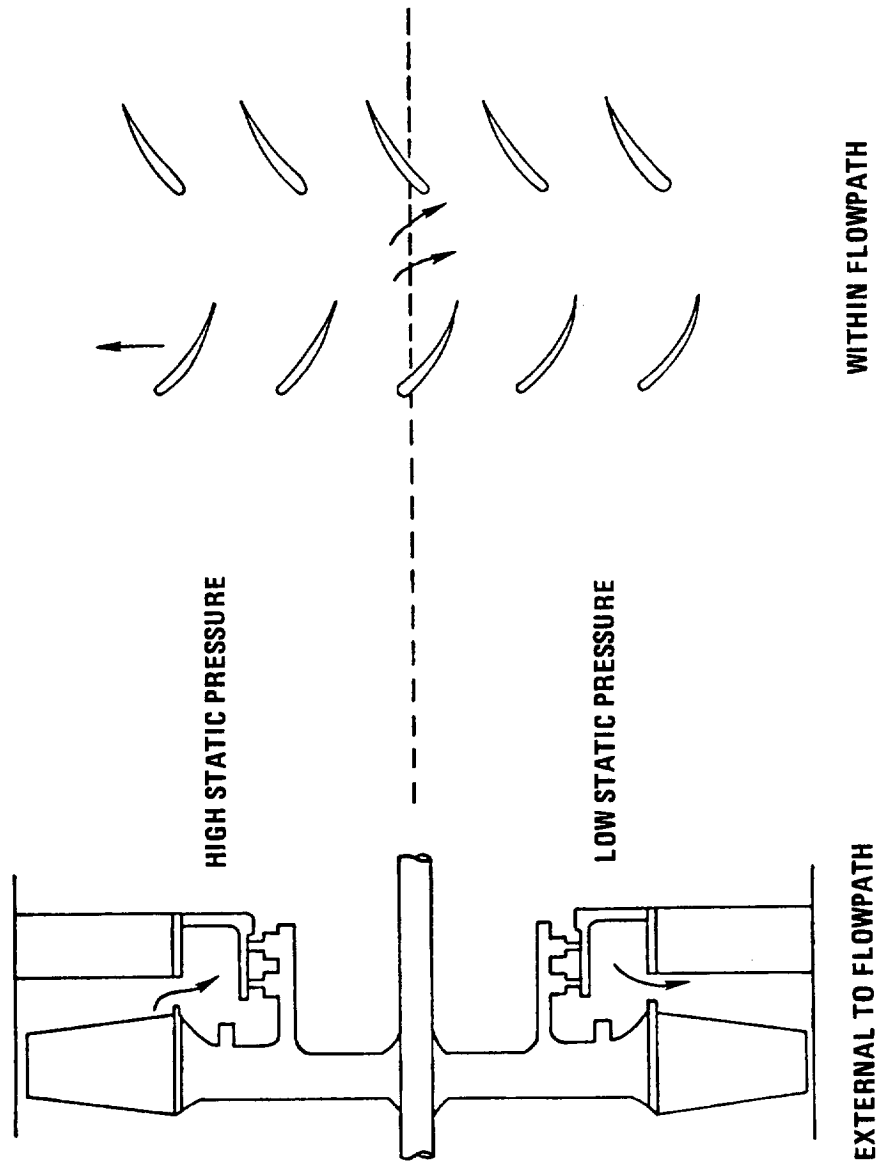

Figure A-5 Circumferential Flow in a Compressor Subjected to Circumferential Inlet Distortion

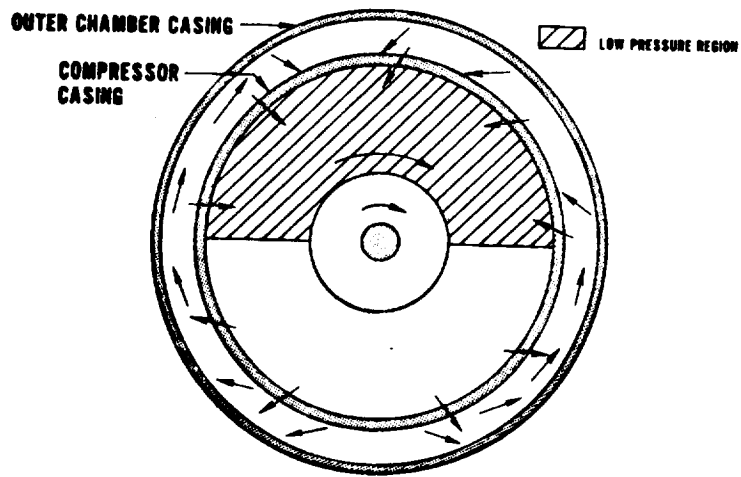

Figure A-6 Flow Redistribution Due to External Flow Chamber

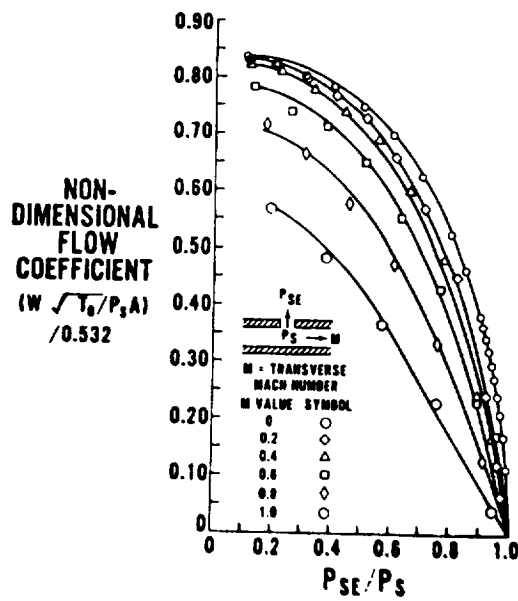

Figure A-7 Flow Coefficients for Passages From Flowpath to External Cavities

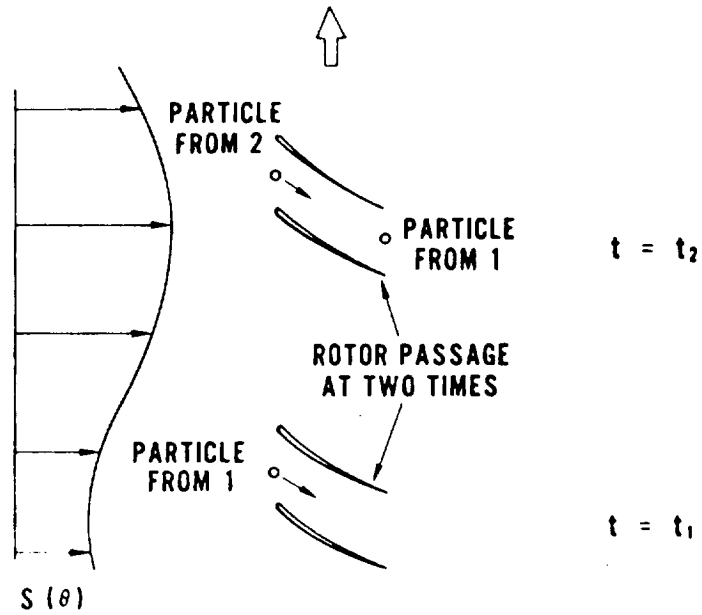

Figure A-8 Entropy Difference Due to Rotor Rotation

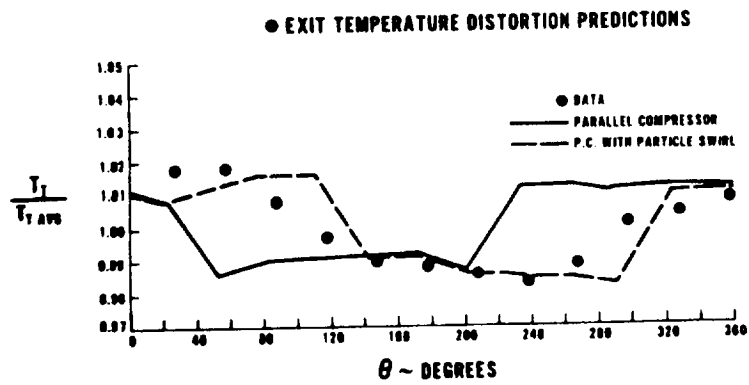

Figure A-9 Particle Swirl Effect

• FRONT TO REAR STAGE MATCH CHANGE REDUCES INLET VELOCITY DISTORTION

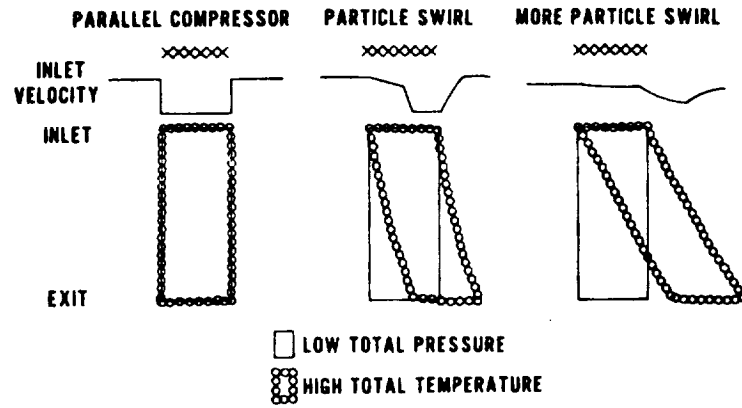

Figure A-10 Particle Swirl Effect

APPENDIX B – PROGRAM OUTPUT SYMBOLS AND TABULAR RESULTS

Legend of Symbols for Distortion Deck Print

Symbol	Description
ALPHA IN DEG	Blade inlet flow angle (absolute frame of reference) measured in degrees
AXIAL VEL	Axial velocity/average axial velocity
AXVELAVG	Circumferential average axial velocity
BETA IN DEG	Blade inlet flow angle (relative frame of reference) measured in degrees
BYPASS RATIO	Ratio of fan duct flow to engine flow
CORR FLOW	Corrected flow
DEG	Degrees
DEG K	Degrees Kelvin
DEG R	Degrees Rankine
DF	Diffusion factor
EXIT	Axial station located at the exit plane of the last row
FLOW SWIRL	Circumferential pressure distortion swirl through the engine
FPS	Feet per second
HPC	High pressure compressor
IGV	Inlet guide vane
INCIDENCE IN DEG	Blade incidence angle measured in degrees
KG/SEC	Kilograms per second
LBM/SEC	Pounds-mass per second

APPENDIX B (Cont'd)

Symbol	Description
MAX-MIN/AVG	Depth of distortion - Maximum total pressure minus the minimum total pressure over the average total pressure
MN	Mach number
MPS	Meters per second
NICORR	Low rotor speed corrected to the inlet
N2CORR	High rotor speed corrected to Station 3.0
N2/N1 (MECH)	Ratio of high rotor mechanical speed to low rotor mechanical speed
PA	Pascals (Newton/Square Meter)
PARTICLE SWIRL	Circumferential particle swirl through the engine
PRESS RATIO	Pressure ratio
PS	Static pressure/average static pressure
PSAVG	Circumferential average static pressure
PSIA	Pounds pressure per square inch absolute
PT	Total pressure/average total pressure
PTAVG	Circumferential average total pressure
REL VEL	Relative velocity/average relative velocity
RVELAVG	Average relative velocity
SEG NO	Segment number
THETA	Circumferential position in direction of rotation
THETM	Theta-minus - extent of distortion
TT	Total temperature/average total temperature

APPENDIX B (Cont'd)

Symbol	Description
TTAVG	Circumferential average total temperature
U	Mean diameter rotor velocity
VEL	Velocity/average velocity (absolute)
VELAVG	Circumferential average velocity
WBL	Cross flow from segment to external cavity
WCORR	Total corrected air flow
2.6F/2	Fan O.D. exit over inlet
3/2	Major Station 3.0 over major Station 2.0
4/3	Major Station 4.0 over major Station 3.0

APPENDIX B - DISTORTION PROGRAM TABULAR OUTPUT

WLOGR=161.44MM/SEC = 62.3K/SEC N2CORR= 7424-RPM N2CORR= 9902-RPM N2/N1(TECH)=1.417
 IM=1R-16G.DIG BYPASS PATIO=1.024 MAX-MIN/AVG=0.045

FAN NO OUTPUT
 FAN NO PERFORMANCE 226F/2 CORR FLOW 112.37 LBM/SEC 50.45 KG/SEC PRESS RATIO 1.395 EFFICIENCY 0.780
 --- RAW OUTPUT ---
 FLOW SWIRL= 0.0 DEG PARTICLE SWIRL= 0.0 DEG PSAVE= 6.77PSIA = 4670.4 PA
 P1AVG= 7.39PSIA = 5095.1 PA T1AVG= 531.0 DEG R = 295.0 DEG C VELAVG= 396.5 FPS = 120.8 MPS
 K1AVG= 1097.2 FPS = 334.4 MPS AXVELAVG= 393.9 FPS = 120.1 MPS U=1024.FPS = 312.MPS

THETA	SECT	VEL	M	PS	PT	TT	WBL	MEL	DF	INCIDENCE	BETA	AXIAL	REL
	NO						LBM/SEC	KG/SEC		IN DEG	IN DEG	VEL	VEL
10.	1	0.997	0.2540	1.0255	1.0251	1.0000	0.0	0.0	-238	4.57	89.0	1.003	0.994
20.	2	0.998	0.2545	1.0253	1.0251	1.0000	0.0	0.0	-228	3.70	88.1	1.004	0.989
30.	3	0.999	0.2547	1.0251	1.0251	1.0000	0.0	0.0	-218	2.76	87.2	1.004	0.984
40.	4	1.000	0.2550	1.0249	1.0251	1.0000	0.0	0.0	-206	1.72	86.1	1.004	0.978
50.	5	1.002	0.2556	1.0245	1.0251	1.0000	0.0	0.0	-191	0.47	84.9	1.005	0.970
60.	6	1.006	0.2572	1.0238	1.0244	1.0000	0.0	0.0	-172	-1.03	83.4	1.005	0.962
70.	7	1.011	0.2591	1.0219	1.0237	1.0000	0.0	0.0	-145	-2.98	81.4	1.006	0.950
80.	8	1.022	0.2631	1.0173	1.0210	1.0000	0.0	0.0	-104	-5.87	78.5	1.008	0.935
90.	9	1.050	0.2660	0.9999	1.0000	1.0000	0.0	0.0	-62	-7.34	77.1	1.010	0.924
100.	10	1.022	0.2633	0.9794	0.9831	1.0000	0.0	0.0	-107	-5.70	78.7	1.009	0.934
110.	11	1.011	0.2593	0.9766	0.9777	1.0000	0.0	0.0	-143	-3.13	81.3	1.006	0.945
120.	12	1.004	0.2565	0.9753	0.9757	1.0000	0.0	0.0	-171	-1.64	83.3	1.003	0.951
130.	13	0.991	0.2545	0.9745	0.9743	1.0000	0.0	0.0	-192	0.58	85.0	1.001	0.971
140.	14	0.995	0.2532	0.9751	0.9742	1.0000	0.0	0.0	-209	1.46	86.4	0.999	0.979
150.	15	0.992	0.2522	0.9755	0.9743	1.0000	0.0	0.0	-221	3.07	87.5	0.998	0.985
160.	16	0.990	0.2510	0.9758	0.9743	1.0000	0.0	0.0	-232	4.04	88.4	0.996	0.990
170.	17	0.989	0.2512	0.9760	0.9743	1.0000	0.0	0.0	-242	4.94	89.3	0.994	0.994
180.	18	0.989	0.2510	0.9761	0.9743	1.0000	0.0	0.0	-251	5.81	90.7	0.995	1.000
190.	19	0.988	0.2509	0.9762	0.9743	1.0000	0.0	0.0	-259	6.67	91.1	0.995	1.005
200.	20	0.988	0.2508	0.9761	0.9743	1.0000	0.0	0.0	-268	7.57	92.0	0.994	1.011
210.	21	0.984	0.2512	0.9760	0.9743	1.0000	0.0	0.0	-277	8.56	93.0	0.994	1.016
220.	22	0.990	0.2516	0.9762	0.9743	1.0000	0.0	0.0	-286	9.70	94.1	0.994	1.023
230.	23	0.992	0.2523	0.9765	0.9750	1.0000	0.0	0.0	-297	11.03	95.4	0.994	1.031
240.	24	0.995	0.2538	0.9770	0.9761	1.0000	0.0	0.0	-308	12.57	97.0	0.995	1.046
250.	25	1.000	0.2552	0.9780	0.9788	1.0000	0.0	0.0	-320	14.35	98.7	0.995	1.051
260.	26	1.004	0.2565	0.9801	0.9815	1.0000	0.0	0.0	-334	16.86	101.3	0.996	1.066
270.	27	1.035	0.2605	0.9776	1.0000	1.0000	0.0	0.0	-342	18.40	102.8	0.996	1.076
280.	28	1.060	0.2682	1.0159	1.0171	1.0000	0.0	0.0	-335	17.01	101.4	0.995	1.067
290.	29	1.060	0.2685	1.0234	1.0233	1.0000	0.0	0.0	-320	14.32	98.7	0.995	1.051
300.	30	0.997	0.2540	1.0249	1.0241	1.0000	0.0	0.0	-305	12.14	96.5	0.997	1.038
310.	31	0.995	0.2535	1.0261	1.0251	1.0000	0.0	0.0	-293	10.52	94.9	0.998	1.024
320.	32	0.995	0.2532	1.0258	1.0251	1.0000	0.0	0.0	-282	9.18	93.6	1.000	1.021
330.	33	0.995	0.2524	1.0258	1.0251	1.0000	0.0	0.0	-272	8.10	92.5	1.001	1.015
340.	34	0.995	0.2525	1.0257	1.0251	1.0000	0.0	0.0	-264	7.14	91.5	1.002	1.009
350.	35	0.996	0.2530	1.0257	1.0251	1.0000	0.0	0.0	-255	6.26	90.7	1.002	1.004
360.	36	0.996	0.2538	1.0256	1.0251	1.0000	0.0	0.0	-246	5.41	89.8	1.003	0.999

STAT 1
 1000

FLOW SWIRL= 0.370 DEG PARTICLE SWIRL= 0.370 DEG PSAVE= 6.67PSIA = 4600.0 PA
 P1AVG= 7.7PSIA = 5075.4 PA T1AVG= 531.6 DEG R = 295.3 DEG C VELAVG= 421.1 FPS = 128.4 MPS
 K1AVG= 919.9 FPS = 281.7 MPS AXVELAVG= 405.4 FPS = 123.8 MPS U=1024.FPS = 312.MPS

THETA	SECT	VEL	M	PS	PT	TT	WBL	MEL	DF	INCIDENCE	BETA	AXIAL	REL
	NO						LBM/SEC	KG/SEC		IN DEG	IN DEG	VEL	VEL
13.	1	1.004	0.2795	1.0243	1.0252	1.0000	0.0	0.0	0.252	5.84	74.7	1.004	1.000
22.	2	1.005	0.2796	1.0242	1.0252	1.0000	0.0	0.0	0.252	5.84	74.7	1.005	1.000
33.	3	1.005	0.2797	1.0242	1.0251	1.0000	0.0	0.0	0.252	5.83	74.7	1.005	1.000
44.	4	1.005	0.2799	1.0241	1.0251	1.0000	0.0	0.0	0.251	5.83	74.7	1.005	1.000
55.	5	1.005	0.2794	1.0240	1.0251	1.0000	0.0	0.0	0.251	5.82	74.7	1.005	1.000
66.	6	1.005	0.2799	1.0237	1.0247	1.0000	0.0	0.0	0.251	5.82	74.7	1.005	1.000
77.	7	1.005	0.2799	1.0228	1.0249	1.0000	0.0	0.0	0.251	5.81	74.7	1.005	1.000
88.	8	1.006	0.2800	1.0198	1.0210	1.0000	0.0	0.0	0.251	5.81	74.7	1.006	1.000
99.	9	1.007	0.2806	0.9984	0.9991	1.0000	0.0	0.0	0.253	5.78	74.7	1.007	1.000
100.	10	1.007	0.2806	0.9817	0.9831	1.0000	0.0	0.0	0.254	5.78	74.7	1.007	1.000
111.	11	1.005	0.2799	0.9769	0.9779	1.0000	0.0	0.0	0.257	5.82	74.7	1.005	1.001
122.	12	1.003	0.2791	0.9753	0.9754	1.0000	0.0	0.0	0.259	5.87	74.1	1.005	1.000
133.	13	1.001	0.2784	0.9746	0.9743	1.0000	0.0	0.0	0.261	5.91	74.1	1.001	1.000
144.	14	1.000	0.2777	0.9743	0.9743	1.0000	0.0	0.0	0.263	5.95	74.0	1.000	1.000
155.	15	0.998	0.2772	0.9746	0.9742	1.0000	0.0	0.0	0.264	5.94	74.0	0.999	1.000
166.	16	0.997	0.2768	0.9747	0.9742	1.0000	0.0	0.0	0.265	6.01	74.0	0.997	1.000
177.	17	0.997	0.2765	0.9749	0.9742	1.0000	0.0	0.0	0.265	6.03	74.0	0.997	1.000
188.	18	0.996	0.2763	0.9750	0.9742	1.0000	0.0	0.0	0.266	6.04	74.0	0.996	1.000
199.	19	0.994	0.2761	0.9751	0.9742	1.0000	0.0	0.0	0.266	6.05	73.9	0.996	1.000
210.	20	0.995	0.2760	0.9751	0.9742	1.0000	0.0	0.0	0.266	6.06	73.9	0.995	1.000
221.	21	0.995	0.2755	0.9751	0.9742	1.0000	0.0	0.0	0.267	6.07	73.9	0.995	1.000
232.	22	0.995	0.2755	0.9755	0.9745	1.0000	0.0	0.0	0.267	6.07	73.9	0.995	1.000
243.	23	0.995	0.2751	0.9761	0.9751	1.0000	0.0	0.0	0.267	6.07	73.9	0.995	1.000
254.	24	0.994	0.2757	0.9772	0.9761	1.0000	0.0	0.0	0.267	6.08	73.9	0.995	1.000
265.	25	0.994	0.2756	0.9750	0.9767	1.0000	0.0	0.0	0.267	6.08	73.9	0.994	1.000
276.	26	0.994	0.2756	0.9823	0.9812	1.0000	0.0	0.0	0.266	6.08	73.9	0.994	1.000
287.	27	0.993	0.2752	1.0004	0.9995	1.0000	0.0	0.0	0.265	6.11	73.9	0.993	1.000
298.	28	0.993	0.2751	1.0182	1.0168	1.0000	0.0	0.0	0.264	6.11	73.9	0.993	1.000
309.	29	0.995	0.2756	1.0243	1.0232	1.0000	0.0	0.0	0.261	6.01	73.9	0.995	1.000
320.	30	0.997	0.2768	1.0249	1.0244	1.0000	0.0	0.0	0.259	6.02	74.0	0.997	1.000
331.	31	0.999	0.2772	1.0256	1.0253	1.0000	0.0	0.0	0.257	5.98	74.0	0.999	1.000
342.	32	1.000	0.2774	1.0250	1.0240	1.0000	0.0	0.0	0.255	5.94	74.1	1.000	1.000
353.	33	1.002	0.2774	1.0245	1.0251	1.0000	0.0	0.0	0.254	5.91	74.1	1.002	1.000
364.	34	1.001	0.2778	1.0244	1.0251	1.0000	0.0	0.0	0.253	5.89	74.1	1.002	1.000
375.	35	1.003	0.2791	1.0245	1.0251	1.0000	0.0	0.0	0.253	5.87	74.1	1.003	1.000
386.	36	1.004	0.2793	1.0244	1.0252	1.0000	0.0	0.0	0.252	5.85	74.1	1.004	1.000

APPENDIX B (Cont'd)

STAGE 1

FLUX SWIRL = 12.120E6 PARTICLE SWIRL = 12.120E6 PSAVG = 6.01PSIA = 55259.7PA
 TTAGV = 460.7FPS = 250.6MPS TTAGV = 575.20DEG K = 319.6DEG K VELAVG = 490.7FPS = 349.6MPS
 VELAVG = 121.7FPS = 250.6MPS AXVELAVG = 466.1FPS = 323.8MPS UE = 990.4FPS = 302.0MPS

THETA DEG	SEC MIN	VEL	MM	PS	PT	TI	WFL LBM/SEC	WFL KG/SEC	LF	INCIDENCE IN DEG	BETA IN DEG	AXIAL DEL VEL	REL VEL
11.	1	1.000	0.4246	1.0211	1.0219	0.9997	0.0	0.0	0.216	-10.07	56.4	1.006	1.006
21.	2	1.000	0.4246	1.0211	1.0219	0.9997	0.0	0.0	0.215	-10.04	56.4	1.006	1.006
31.	3	1.000	0.4247	1.0219	1.0219	0.9991	0.0	0.0	0.215	-10.06	56.5	1.006	1.006
41.	4	1.000	0.4247	1.0219	1.0219	0.9991	0.0	0.0	0.215	-10.07	56.5	1.006	1.006
51.	5	0.999	0.4248	1.0216	1.0218	0.9991	0.0	0.0	0.214	-10.08	56.5	1.007	1.007
61.	6	0.999	0.4248	1.0214	1.0214	0.9990	0.0	0.0	0.214	-10.09	56.5	1.007	1.007
71.	7	0.999	0.4248	1.0206	1.0205	0.9984	0.0	0.0	0.214	-10.09	56.5	1.007	1.007
81.	8	0.999	0.4248	1.0173	1.0172	0.9987	0.0	0.0	0.214	-10.08	56.5	1.007	1.007
91.	9	0.998	0.4244	0.9931	0.9929	0.9928	0.0	0.0	0.217	-9.94	56.4	1.006	1.006
101.	10	0.994	0.4235	0.9796	0.9784	0.9793	0.0	0.0	0.219	-9.84	56.2	1.004	1.004
111.	11	0.993	0.4228	0.9784	0.9774	0.9779	0.0	0.0	0.224	-9.65	56.0	1.002	1.002
121.	12	0.995	0.4227	0.9786	0.9775	0.9945	0.0	0.0	0.228	-9.43	55.6	1.000	1.000
131.	13	0.996	0.4229	0.9776	0.9766	0.9999	0.0	0.0	0.231	-9.26	55.7	0.998	0.998
141.	14	0.997	0.4225	0.9781	0.9773	1.0006	0.0	0.0	0.234	-9.14	55.5	0.997	0.997
151.	15	0.998	0.4236	0.9781	0.9775	1.0007	0.0	0.0	0.236	-9.04	55.4	0.996	0.996
161.	16	0.999	0.4239	0.9779	0.9775	1.0008	0.0	0.0	0.237	-8.98	55.4	0.995	0.995
171.	17	0.999	0.4241	0.9776	0.9775	1.0001	0.0	0.0	0.238	-8.93	55.3	0.995	0.995
181.	18	1.000	0.4243	0.9777	0.9775	1.0004	0.0	0.0	0.239	-8.90	55.3	0.994	0.994
191.	19	1.000	0.4244	0.9776	0.9774	1.0009	0.0	0.0	0.246	-8.87	55.3	0.994	0.994
201.	20	1.000	0.4246	0.9775	0.9774	1.0004	0.0	0.0	0.240	-8.85	55.3	0.994	0.994
211.	21	1.000	0.4246	0.9774	0.9774	1.0006	0.0	0.0	0.240	-8.84	55.2	0.994	0.994
221.	22	1.001	0.4247	0.9778	0.9778	1.0010	0.0	0.0	0.246	-8.83	55.2	0.993	0.993
231.	23	1.001	0.4247	0.9784	0.9784	1.0011	0.0	0.0	0.241	-8.82	55.2	0.993	0.993
241.	24	1.001	0.4249	0.9794	0.9795	1.0012	0.0	0.0	0.241	-8.82	55.2	0.994	0.994
251.	25	1.001	0.4249	0.9822	0.9823	1.0017	0.0	0.0	0.240	-8.84	55.2	0.994	0.994
261.	26	1.002	0.4250	0.9844	0.9846	1.0017	0.0	0.0	0.240	-8.86	55.3	0.995	0.995
271.	27	1.004	0.4251	1.0058	1.0058	1.0065	0.0	0.0	0.238	-8.78	55.2	0.994	0.994
281.	28	1.006	0.4258	1.0212	1.0219	1.0065	0.0	0.0	0.235	-9.09	55.3	0.994	0.994
291.	29	1.005	0.4265	1.0230	1.0241	1.0025	0.0	0.0	0.231	-9.21	55.7	0.998	0.998
301.	30	1.004	0.4266	1.0214	1.0225	1.0002	0.0	0.0	0.227	-9.47	55.0	1.000	1.000
311.	31	1.004	0.4263	1.0210	1.0229	0.9999	0.0	0.0	0.224	-9.44	56.0	1.002	1.002
321.	32	1.005	0.4260	1.0212	1.0220	0.9993	0.0	0.0	0.221	-9.78	56.2	1.005	1.005
331.	33	1.002	0.4257	1.0214	1.0220	0.9993	0.0	0.0	0.219	-9.85	56.2	1.004	1.004
341.	34	1.001	0.4254	1.0215	1.0220	0.9995	0.0	0.0	0.218	-9.91	56.3	1.005	1.005
351.	35	1.001	0.4252	1.0216	1.0219	0.9992	0.0	0.0	0.217	-9.96	56.4	1.005	1.005
36	36	1.000	0.4250	1.0217	1.0219	0.9992	0.0	0.0	0.216	-10.00	56.4	1.006	1.006

STAGE 2

FLUX SWIRL = 5.550E6 PARTICLE SWIRL = 16.560E6 PSAVG = 8.29PSIA = 57156.7PA
 TTAGV = 9.16FPS = 63317.7PA TTAGV = 575.20DEG K = 319.6DEG K VELAVG = 446.4FPS = 136.1MPS
 VELAVG = 931.6FPS = 294.0MPS AXVELAVG = 424.2FPS = 129.3MPS UE = 969.4FPS = 295.0MPS

THETA DEG	SEC MIN	VEL	MM	PS	PT	TI	WFL LBM/SEC	WFL KG/SEC	LF	INCIDENCE IN DEG	BETA IN DEG	AXIAL DEL VEL	REL VEL
10.	1	1.007	0.3880	1.0209	1.0224	0.9997	0.0	0.0	0.136	6.73	27.3	1.007	1.000
20.	2	1.007	0.3881	1.0209	1.0224	0.9991	0.0	0.0	0.130	6.73	27.3	1.007	1.001
30.	3	1.007	0.3882	1.0208	1.0224	0.9991	0.0	0.0	0.130	6.72	27.3	1.007	1.001
40.	4	1.007	0.3881	1.0208	1.0224	0.9991	0.0	0.0	0.129	6.72	27.3	1.007	1.001
50.	5	1.007	0.3883	1.0204	1.0224	0.9991	0.0	0.0	0.129	6.71	27.3	1.007	1.001
60.	6	1.007	0.3883	1.0204	1.0226	0.9990	0.0	0.0	0.129	6.71	27.3	1.007	1.001
70.	7	1.007	0.3884	1.0195	1.0212	0.9989	0.0	0.0	0.130	6.71	27.3	1.007	1.001
80.	8	1.007	0.3884	1.0162	1.0180	0.9987	0.0	0.0	0.137	6.75	27.3	1.006	1.000
90.	9	1.006	0.3890	0.9927	0.9941	0.9978	0.0	0.0	0.144	6.79	27.2	1.004	1.000
100.	10	1.004	0.3881	0.9785	0.9798	0.9974	0.0	0.0	0.148	6.86	27.1	1.002	1.000
110.	11	1.002	0.3884	0.9783	0.9787	0.9974	0.0	0.0	0.150	6.92	27.1	1.000	1.000
120.	12	1.000	0.3852	0.9784	0.9786	0.9985	0.0	0.0	0.152	6.98	27.0	0.998	1.000
130.	13	0.998	0.3843	0.9778	0.9773	0.9999	0.0	0.0	0.154	1.01	27.0	0.996	1.000
140.	14	0.996	0.3830	0.9785	0.9777	1.0006	0.0	0.0	0.154	1.04	27.0	0.995	1.000
150.	15	0.995	0.3831	0.9787	0.9776	1.0001	0.0	0.0	0.155	1.06	26.9	0.994	1.000
160.	16	0.994	0.3827	0.9786	0.9774	1.0007	0.0	0.0	0.156	1.01	26.9	0.994	1.000
170.	17	0.994	0.3826	0.9786	0.9771	1.0008	0.0	0.0	0.156	1.04	26.9	0.994	1.000
180.	18	0.994	0.3825	0.9785	0.9770	1.0004	0.0	0.0	0.156	1.10	26.9	0.993	1.000
190.	19	0.993	0.3825	0.9786	0.9774	1.0004	0.0	0.0	0.157	1.10	26.9	0.993	0.999
200.	20	0.993	0.3822	0.9784	0.9768	1.0004	0.0	0.0	0.157	1.11	26.9	0.993	0.999
210.	21	0.993	0.3821	0.9787	0.9771	1.0010	0.0	0.0	0.157	1.11	26.9	0.993	0.999
220.	22	0.993	0.3821	0.9784	0.9774	1.0011	0.0	0.0	0.157	1.11	26.9	0.993	0.999
230.	23	0.993	0.3821	0.9784	0.9788	1.0017	0.0	0.0	0.156	1.11	26.9	0.993	0.999
240.	24	0.993	0.3820	0.9831	0.9815	1.0017	0.0	0.0	0.155	1.10	26.9	0.993	0.999
250.	25	0.993	0.3821	0.9854	0.9838	1.0017	0.0	0.0	0.150	1.07	26.9	0.994	1.000
260.	26	0.994	0.3825	1.0214	1.0204	1.0063	0.0	0.0	0.143	1.03	27.0	0.996	1.000
270.	27	0.991	0.3839	1.0235	1.0228	1.0025	0.0	0.0	0.139	0.97	27.0	0.998	1.000
280.	28	1.000	0.3852	1.0216	1.0216	1.0007	0.0	0.0	0.137	0.91	27.1	1.000	1.000
290.	29	1.007	0.3860	1.0211	1.0223	0.9999	0.0	0.0	0.135	0.86	27.1	1.002	1.000
300.	30	1.003	0.3867	1.0209	1.0217	0.9993	0.0	0.0	0.134	0.82	27.2	1.003	1.000
310.	31	1.005	0.3871	1.0204	1.0219	0.9993	0.0	0.0	0.133	0.79	27.2	1.005	1.000
320.	32	1.001	0.3877	1.0209	1.0221	0.9994	0.0	0.0	0.132	0.77	27.2	1.005	1.000
330.	33	1.001	0.3877	1.0209	1.0222	0.9994	0.0	0.0	0.131	0.75	27.2	1.006	1.000
340.	34	1.006	0.3876	1.0204	1.0223	0.9992	0.0	0.0	0.130	0.74	27.3	1.006	1.000

APPENDIX B (Cont'd)

STATUS

FLUM SWIRL= 2.85000 PARTICLE SWIRL= 20.78166 PS AVG= 9.31PSIA = 64157.7A
 P1AVG= 10.46PSIA = 71706.7A TTAVG= 603.10EGR = 335.00FIR K VELAVG= 6.47FPS = 257.5MPS AXVELAVG= 423.7FPS = 129.0MPS U= 940.7FPS = 280.0MPS
 VE LAVG= 476.3FPS = 145.2MPS

TRITA	SEC NO	VEL	MN	PS	PT	TT	MFL LBM/SEC	MFL KG/SEC	DF	INCIDENCE IN DEG	BETA IN DEG	AXIAL VFL	R/L VFL
13.	1	1.001	0.4027	1.0170	1.0174	0.9918	0.0	0.0	0.182	-22.25	63.8	1.010	1.010
23.	2	1.001	0.4027	1.0170	1.0174	0.9918	0.0	0.0	0.182	-22.28	63.8	1.011	1.011
33.	3	1.001	0.4027	1.0170	1.0174	0.9918	0.0	0.0	0.181	-22.30	63.8	1.011	1.011
43.	4	1.001	0.4027	1.0170	1.0174	0.9918	0.0	0.0	0.181	-22.31	63.8	1.011	1.011
53.	5	1.001	0.4027	1.0170	1.0174	0.9918	0.0	0.0	0.181	-22.32	63.8	1.011	1.011
63.	6	1.001	0.4026	1.0166	1.0170	0.9917	0.0	0.0	0.181	-22.32	63.8	1.011	1.011
73.	7	1.001	0.4026	1.0159	1.0163	0.9925	0.0	0.0	0.181	-22.31	63.8	1.011	1.011
83.	8	1.001	0.4026	1.0132	1.0135	0.9971	0.0	0.0	0.181	-22.31	63.8	1.011	1.011
93.	9	0.998	0.4027	0.9928	0.9932	0.9922	0.0	0.0	0.182	-22.24	63.7	1.010	1.010
103.	10	0.995	0.4015	0.9804	0.9802	0.9909	0.0	0.0	0.191	-21.73	63.2	1.005	1.005
113.	11	0.996	0.4003	0.9817	0.9808	0.9956	0.0	0.0	0.200	-21.18	62.7	1.006	1.006
123.	12	0.995	0.4000	0.9834	0.9824	0.9996	0.0	0.0	0.207	-20.86	62.4	0.997	0.997
133.	13	0.996	0.4003	0.9828	0.9819	1.0000	0.0	0.0	0.210	-20.87	62.2	0.995	0.995
143.	14	0.997	0.4004	0.9831	0.9823	1.0007	0.0	0.0	0.213	-20.50	62.0	0.993	0.993
153.	15	0.998	0.4007	0.9830	0.9824	1.0011	0.0	0.0	0.215	-20.40	61.9	0.992	0.992
163.	16	0.998	0.4009	0.9826	0.9822	1.0011	0.0	0.0	0.217	-20.32	61.8	0.991	0.991
173.	17	0.998	0.4010	0.9826	0.9821	1.0011	0.0	0.0	0.218	-20.26	61.8	0.991	0.991
183.	18	0.999	0.4011	0.9824	0.9819	1.0011	0.0	0.0	0.219	-20.22	61.7	0.990	0.990
193.	19	0.999	0.4011	0.9823	0.9818	1.0012	0.0	0.0	0.219	-20.19	61.7	0.990	0.990
203.	20	0.999	0.4012	0.9822	0.9818	1.0012	0.0	0.0	0.220	-20.16	61.7	0.990	0.990
213.	21	0.999	0.4012	0.9821	0.9817	1.0012	0.0	0.0	0.220	-20.15	61.6	0.990	0.990
223.	22	0.999	0.4012	0.9824	0.9820	1.0012	0.0	0.0	0.220	-20.13	61.6	0.989	0.989
233.	23	0.999	0.4012	0.9829	0.9826	1.0014	0.0	0.0	0.220	-20.13	61.6	0.989	0.989
243.	24	0.999	0.4013	0.9838	0.9834	1.0014	0.0	0.0	0.220	-20.14	61.6	0.989	0.989
253.	25	1.000	0.4013	0.9861	0.9858	1.0021	0.0	0.0	0.220	-20.16	61.7	0.990	0.990
263.	26	1.000	0.4014	0.9881	0.9879	1.0023	0.0	0.0	0.219	-20.22	61.7	0.990	0.990
273.	27	1.002	0.4012	1.0061	1.0057	1.0076	0.0	0.0	0.218	-20.28	61.8	0.991	0.991
283.	28	1.005	0.4020	1.0200	1.0201	1.0089	0.0	0.0	0.211	-20.69	62.2	0.995	0.995
293.	29	1.000	0.4032	1.0203	1.0210	1.0049	0.0	0.0	0.207	-21.22	62.7	1.000	1.000
303.	30	1.005	0.4036	1.0172	1.0182	1.0009	0.0	0.0	0.195	-21.55	63.0	1.003	1.003
313.	31	1.004	0.4034	1.0171	1.0179	0.9996	0.0	0.0	0.192	-21.72	63.2	1.005	1.005
323.	32	1.003	0.4033	1.0166	1.0173	0.9991	0.0	0.0	0.189	-21.86	63.4	1.006	1.006
333.	33	1.002	0.4031	1.0167	1.0173	0.9989	0.0	0.0	0.187	-21.97	63.5	1.007	1.007
343.	34	1.002	0.4029	1.0168	1.0174	0.9989	0.0	0.0	0.186	-22.05	63.6	1.008	1.008
353.	35	1.002	0.4028	1.0169	1.0174	0.9989	0.0	0.0	0.184	-22.12	63.6	1.009	1.009
36.	36	1.002	0.4028	1.0169	1.0174	0.9989	0.0	0.0	0.183	-22.18	63.7	1.010	1.010
									0.183	-22.22	63.7	1.010	1.010

STAGE 3
KATOR

FLUM SWIRL= 6.31000 PARTICLE SWIRL= 24.24000 PS AVG= 9.42PSIA = 64941.7A
 P1AVG= 10.40PSIA = 71735.7A TTAVG= 603.10EGR = 335.00FIR K VELAVG= 6.47FPS = 294.6MPS AXVELAVG= 444.7FPS = 135.5MPS U= 931.7FPS = 284.4MPS
 VE LAVG= 458.7FPS = 137.4MPS

TRITA	SEC NO	VEL	MN	PS	PT	TT	MFL LBM/SEC	MFL KG/SEC	DF	INCIDENCE IN DEG	BETA IN DEG	AXIAL VFL	R/L VFL
16.	1	1.012	0.3845	1.0153	1.0177	0.9988	0.0	0.0	-0.057	-2.29	27.7	1.012	1.002
26.	2	1.012	0.3846	1.0152	1.0178	0.9988	0.0	0.0	-0.058	-2.30	27.7	1.012	1.002
36.	3	1.012	0.3847	1.0152	1.0178	0.9988	0.0	0.0	-0.057	-2.31	27.7	1.012	1.002
46.	4	1.012	0.3847	1.0152	1.0178	0.9988	0.0	0.0	-0.058	-2.31	27.7	1.012	1.002
56.	5	1.012	0.3848	1.0151	1.0178	0.9988	0.0	0.0	-0.058	-2.31	27.7	1.012	1.002
66.	6	1.012	0.3848	1.0146	1.0174	0.9988	0.0	0.0	-0.057	-2.31	27.7	1.012	1.002
76.	7	1.012	0.3848	1.0141	1.0167	0.9985	0.0	0.0	-0.057	-2.31	27.7	1.012	1.002
86.	8	1.012	0.3846	1.0113	1.0139	0.9978	0.0	0.0	-0.056	-2.31	27.7	1.012	1.002
96.	9	1.000	0.3838	0.9912	0.9932	0.9922	0.0	0.0	-0.054	-2.29	27.7	1.012	1.002
106.	10	1.000	0.3817	0.9795	0.9864	0.9909	0.0	0.0	-0.035	-2.16	27.6	1.006	1.001
116.	11	0.996	0.3792	0.9617	0.9814	0.9956	0.0	0.0	-0.021	-2.01	27.4	1.000	1.000
126.	12	0.994	0.3776	0.9441	0.9829	0.9990	0.0	0.0	-0.021	-1.91	27.3	0.996	0.999
136.	13	0.992	0.3766	0.9438	0.9822	1.0000	0.0	0.0	-0.024	-1.85	27.2	0.994	0.999
146.	14	0.991	0.3760	0.9443	0.9824	1.0000	0.0	0.0	-0.025	-1.80	27.2	0.992	0.999
156.	15	0.990	0.3756	0.9445	0.9823	1.0011	0.0	0.0	-0.025	-1.77	27.2	0.991	0.999
166.	16	0.989	0.3754	0.9443	0.9821	1.0011	0.0	0.0	-0.025	-1.75	27.1	0.990	0.999
176.	17	0.989	0.3752	0.9442	0.9818	1.0011	0.0	0.0	-0.025	-1.73	27.1	0.989	0.998
186.	18	0.989	0.3750	0.9441	0.9817	1.0011	0.0	0.0	-0.025	-1.72	27.1	0.989	0.998
196.	19	0.988	0.3749	0.9440	0.9815	1.0017	0.0	0.0	-0.025	-1.71	27.1	0.989	0.998
206.	20	0.988	0.3748	0.9439	0.9814	1.0012	0.0	0.0	-0.024	-1.70	27.1	0.988	0.998
216.	21	0.988	0.3748	0.9438	0.9813	1.0012	0.0	0.0	-0.024	-1.70	27.1	0.988	0.998
226.	22	0.988	0.3747	0.9442	0.9816	1.0011	0.0	0.0	-0.024	-1.69	27.1	0.988	0.998
236.	23	0.988	0.3747	0.9442	0.9816	1.0011	0.0	0.0	-0.024	-1.69	27.1	0.988	0.998
246.	24	0.988	0.3748	0.9445	0.9820	1.0014	0.0	0.0	-0.025	-1.69	27.1	0.988	0.998
256.	25	0.989	0.3749	0.9449	0.9824	1.0016	0.0	0.0	-0.026	-1.70	27.1	0.988	0.998
266.	26	0.990	0.3752	0.9498	0.9825	1.0021	0.0	0.0	-0.028	-1.72	27.1	0.989	0.998
276.	27	0.994	0.3759	1.0177	1.0057	1.0073	0.0	0.0	-0.030	-1.73	27.1	0.990	0.998
286.	28	0.999	0.3777	1.0211	1.0206	1.0085	0.0	0.0	-0.048	-1.84	27.2	0.994	0.999
296.	29	1.005	0.3800	1.0204	1.0205	1.0049	0.0	0.0	-0.062	-1.98	27.4	0.999	1.000
306.	30	1.005	0.3817	1.0167	1.0177	1.0009	0.0	0.0	-0.063	-2.08	27.5	1.003	1.000
316.	31	1.007	0.3826	1.0162	1.0176	0.9996	0.0	0.0	-0.060	-2.14	27.5	1.005	1.001
326.	32	1.008	0.3833	1.0154	1.0176	0.9996	0.0	0.0	-0.058	-2.18	27.6	1.007	1.001
336.	33	1.004	0.3836	1.0153	1.0172	0.9991	0.0	0.0	-0.057	-2.21	27.6	1.008	1.001
346.	34	1.010	0.3837	1.0153	1.0175	0.9985	0.0	0.0	-0.057	-2.24	27.6	1.009	1.001
356.	35	1.011	0.3841	1.0153	1.0176	0.9989	0.0	0.0	-0.057	-2.26	27.7	1.010	1.001
36.	36	1.011	0.3843	1.0153	1.0177	0.9988	0.0	0.0	-0.057	-2.27	27.7	1.011	1.002
									-0.057	-2.29	27.7	1.011	1.002

REPRODUCIBILITY OF THE
QUALITY OF THE FOOD

APPENDIX B (Cont'd)

STATOR FLOW SWIRL = 4.81 DEG PARTICLE SWIRL = 26.14 DEG PS AVG = 9.67 FPS IA = 6666 G PA
PI AVG = 10.32 FPS IA = 74639 PA TT AVG = 599.60 DEG R = 332.80 DEG K VEL AVG = 463.9 FPS = 147.5 MPS
K VEL AVG = 597.4 FPS = 364.1 MPS AX VEL AVG = 476.4 FPS = 147.2 MPS U = 961.1 FPS = 293.1 MPS

INLET	SEG NO	VEL	MN	PS	PT	TT	WFL LHM/SEC	WFL KG/SEC	DF	INCIDENCE IN DEG	ALPHA IN DEG	AXIAL VEL	REL VEL
15	1	1.000	0.4150	1.0006	1.0114	0.9929	0.0	0.0	-0.42	-27.24	81.3	1.012	1.012
25	2	1.000	0.4150	1.0008	1.0115	0.9927	0.0	0.0	-0.42	-27.29	81.3	1.012	1.012
35	3	1.001	0.4150	1.0009	1.0117	0.9926	0.0	0.0	-0.42	-27.29	81.3	1.012	1.012
45	4	1.001	0.4150	1.0008	1.0116	0.9925	0.0	0.0	-0.43	-27.30	81.3	1.012	1.012
55	5	1.005	0.4150	1.0009	1.0117	0.9924	0.0	0.0	-0.43	-27.30	81.3	1.012	1.012
65	6	1.004	0.4149	1.0009	1.0116	0.9924	0.0	0.0	-0.42	-27.27	81.3	1.012	1.012
75	7	1.007	0.4148	1.0008	1.0115	0.9923	0.0	0.0	-0.41	-27.22	81.1	1.011	1.011
85	8	1.006	0.4148	1.0007	1.0110	0.9922	0.0	0.0	-0.39	-27.61	81.0	1.010	1.010
95	9	0.996	0.4091	1.0013	1.0007	0.9909	0.0	0.0	-0.17	-25.47	79.5	0.996	0.996
105	10	0.996	0.4050	0.9959	0.9934	0.9921	0.0	0.0	-0.01	-24.34	78.4	0.996	0.996
115	11	0.997	0.4050	0.9941	0.9913	0.9907	0.0	0.0	0.00	-24.55	78.5	0.998	0.998
125	12	0.984	0.4050	0.9935	0.9907	0.9897	0.0	0.0	0.00	-24.57	78.6	0.998	0.998
135	13	0.990	0.4050	0.9925	0.9897	0.9887	0.0	0.0	0.00	-24.57	78.6	0.998	0.998
145	14	0.991	0.4051	0.9922	0.9895	0.9885	0.0	0.0	0.00	-24.66	78.6	0.998	0.998
155	15	0.991	0.4051	0.9911	0.9891	0.9882	0.0	0.0	0.00	-24.66	78.6	0.998	0.998
165	16	0.992	0.4051	0.9916	0.9888	0.9878	0.0	0.0	0.00	-24.58	78.6	0.998	0.998
175	17	0.995	0.4050	0.9915	0.9887	0.9878	0.0	0.0	0.00	-24.55	78.6	0.998	0.998
185	18	0.992	0.4050	0.9913	0.9885	0.9875	0.0	0.0	0.00	-24.53	78.5	0.997	0.997
195	19	0.992	0.4050	0.9911	0.9884	0.9874	0.0	0.0	0.00	-24.53	78.5	0.997	0.997
205	20	0.992	0.4049	0.9910	0.9882	0.9872	0.0	0.0	0.00	-24.51	78.5	0.997	0.997
215	21	0.992	0.4050	0.9909	0.9881	0.9871	0.0	0.0	0.00	-24.51	78.5	0.997	0.997
225	22	0.992	0.4050	0.9911	0.9883	0.9873	0.0	0.0	0.00	-24.52	78.5	0.997	0.997
235	23	0.992	0.4051	0.9912	0.9885	0.9875	0.0	0.0	0.00	-24.57	78.6	0.998	0.998
245	24	0.995	0.4050	0.9914	0.9888	0.9878	0.0	0.0	0.00	-24.64	78.6	0.998	0.998
255	25	0.994	0.4050	0.9922	0.9895	0.9885	0.0	0.0	-0.42	-24.83	78.6	0.990	0.990
265	26	0.995	0.4064	0.9931	0.9910	1.0005	0.0	0.0	-0.04	-24.99	79.0	0.992	0.992
275	27	1.005	0.4105	0.9985	0.9967	1.0006	0.0	0.0	-0.24	-26.40	80.4	1.004	1.004
285	28	1.014	0.4141	1.0041	1.0063	1.0078	0.0	0.0	-0.40	-27.52	81.5	1.014	1.014
295	29	1.034	0.4151	1.0061	1.0090	1.0036	0.0	0.0	-0.43	-27.66	81.7	1.015	1.015
305	30	1.011	0.4140	1.0061	1.0054	0.9985	0.0	0.0	-0.41	-27.39	81.4	1.013	1.013
315	31	1.009	0.4146	1.0074	1.0101	0.9965	0.0	0.0	-0.41	-27.78	81.3	1.012	1.012
325	32	1.008	0.4147	1.0076	1.0103	0.9967	0.0	0.0	-0.41	-27.22	81.2	1.011	1.011
335	33	1.007	0.4148	1.0079	1.0106	0.9960	0.0	0.0	-0.41	-27.23	81.2	1.012	1.012
345	34	1.001	0.4147	1.0062	1.0109	0.9955	0.0	0.0	-0.41	-27.25	81.2	1.012	1.012
355	35	1.001	0.4149	1.0064	1.0112	0.9953	0.0	0.0	-0.42	-27.24	81.3	1.012	1.012
36	36	1.008	0.4150	1.0084	1.0117	0.9950	0.0	0.0	-0.42	-27.29	81.3	1.012	1.012

STATOR FLOW SWIRL = 7.42 DEG PARTICLE SWIRL = 30.74 DEG PS AVG = 6.98 FPS IA = 61913 PA
PI AVG = 10.31 FPS IA = 71063 PA TT AVG = 599.00 DEG R = 332.80 DEG K VEL AVG = 527.2 FPS = 160.7 MPS
K VEL AVG = 0.0 FPS = 0.0 MPS AX VEL AVG = 0.0 FPS = 0.0 MPS U = 961.1 FPS = 293.1 MPS

INLET	SEG NO	VEL	MN	PS	PT	TT	WFL LHM/SEC	WFL KG/SEC	DF	INCIDENCE IN DEG	ALPHA IN DEG	AXIAL VEL	REL VEL
17	1	1.020	0.4590	1.0000	1.0066	0.9924	0.0	0.0	0.0	0.0	0.0	0.0	0.0
27	2	1.020	0.4591	0.9999	1.0066	0.9927	0.0	0.0	0.0	0.0	0.0	0.0	0.0
37	3	1.020	0.4591	1.0001	1.0066	0.9926	0.0	0.0	0.0	0.0	0.0	0.0	0.0
47	4	1.020	0.4592	0.9999	1.0067	0.9925	0.0	0.0	0.0	0.0	0.0	0.0	0.0
57	5	1.020	0.4592	1.0000	1.0067	0.9924	0.0	0.0	0.0	0.0	0.0	0.0	0.0
67	6	1.020	0.4590	1.0001	1.0067	0.9924	0.0	0.0	0.0	0.0	0.0	0.0	0.0
77	7	1.019	0.4587	1.0001	1.0065	0.9923	0.0	0.0	0.0	0.0	0.0	0.0	0.0
87	8	1.018	0.4575	1.0000	1.0057	0.9922	0.0	0.0	0.0	0.0	0.0	0.0	0.0
97	9	0.997	0.4461	1.0001	1.0003	0.9900	0.0	0.0	0.0	0.0	0.0	0.0	0.0
107	10	0.985	0.4417	1.0000	0.9961	0.9921	0.0	0.0	0.0	0.0	0.0	0.0	0.0
117	11	0.981	0.4398	1.0000	0.9956	0.9927	0.0	0.0	0.0	0.0	0.0	0.0	0.0
127	12	0.982	0.4398	1.0000	0.9946	0.9914	0.0	0.0	0.0	0.0	0.0	0.0	0.0
137	13	0.991	0.4384	1.0000	0.9941	1.0040	0.0	0.0	0.0	0.0	0.0	0.0	0.0
147	14	0.991	0.4380	1.0001	0.9940	1.0054	0.0	0.0	0.0	0.0	0.0	0.0	0.0
157	15	0.981	0.4375	1.0000	0.9937	1.0062	0.0	0.0	0.0	0.0	0.0	0.0	0.0
167	16	0.980	0.4375	1.0000	0.9936	1.0066	0.0	0.0	0.0	0.0	0.0	0.0	0.0
177	17	0.980	0.4372	1.0001	0.9935	1.0069	0.0	0.0	0.0	0.0	0.0	0.0	0.0
187	18	0.980	0.4370	1.0001	0.9934	1.0071	0.0	0.0	0.0	0.0	0.0	0.0	0.0
197	19	0.980	0.4370	0.9999	0.9932	1.0072	0.0	0.0	0.0	0.0	0.0	0.0	0.0
207	20	0.979	0.4368	1.0000	0.9932	1.0073	0.0	0.0	0.0	0.0	0.0	0.0	0.0
217	21	0.979	0.4368	0.9999	0.9931	1.0073	0.0	0.0	0.0	0.0	0.0	0.0	0.0
227	22	0.979	0.4365	1.0000	0.9933	1.0075	0.0	0.0	0.0	0.0	0.0	0.0	0.0
237	23	0.979	0.4371	1.0000	0.9933	1.0075	0.0	0.0	0.0	0.0	0.0	0.0	0.0
247	24	0.981	0.4371	1.0000	0.9935	1.0076	0.0	0.0	0.0	0.0	0.0	0.0	0.0
257	25	0.983	0.4365	0.9999	0.9942	1.0076	0.0	0.0	0.0	0.0	0.0	0.0	0.0
267	26	0.985	0.4395	1.0001	0.9949	1.0075	0.0	0.0	0.0	0.0	0.0	0.0	0.0
277	27	1.003	0.4474	0.9998	0.9992	1.0086	0.0	0.0	0.0	0.0	0.0	0.0	0.0
287	28	1.018	0.4545	1.0001	1.0036	1.0078	0.0	0.0	0.0	0.0	0.0	0.0	0.0
297	29	1.021	0.4570	1.0000	1.0053	1.0036	0.0	0.0	0.0	0.0	0.0	0.0	0.0
307	30	1.019	0.4572	1.0000	1.0054	0.9980	0.0	0.0	0.0	0.0	0.0	0.0	0.0
317	31	1.011	0.4576	1.0001	1.0051	0.9960	0.0	0.0	0.0	0.0	0.0	0.0	0.0
327	32	1.018	0.4575	1.0000	1.0054	0.9947	0.0	0.0	0.0	0.0	0.0	0.0	0.0
337	33	1.019	0.4512	0.9999	1.0066	0.9940	0.0	0.0	0.0	0.0	0.0	0.0	0.0
347	34	1.014	0.4515	1.0000	1.0062	0.9955	0.0	0.0	0.0	0.0	0.0	0.0	0.0
357	35	1.014	0.4516	1.0000	1.0064	0.9933	0.0	0.0	0.0	0.0	0.0	0.0	0.0
36	36	1.020	0.4519	0.9998	1.0064	0.9936	0.0	0.0	0.0	0.0	0.0	0.0	0.0

APPENDIX B (Cont'd)

LOW SPND OUTPUT

CORR FLOW PRESS RATIO EFFICIENCY
 LOW SPND PERFORMANCE 2/2 69.44 LBM/SEC 3.430 0.867
 31.50 KF/SEC

PAKE CORRECTED PRESSURE RATIO = 3.269
 ---- POW OUTPUT ----

IGV

FLOW SWIRL= 0.0 DEG PARTICLE SWIRL= 0.0 DEG PSAVG= 6.777PSIA = 46664.PA
 PTAVG= 7.79PSIA = 50951.PA TTAVG= 531.0DEG R = 295.0DEG K VELAVG= 397.1FPS = 121.0MPS
 FVELAVG= 752.6FPS = 229.5MPS AXVELAVG= 395.4FPS = 120.5MPS U= 640.FPS = 195.MPS

THETA	SPD	VFL	W	PS	PT	TT	WRL	WFL	DF	INCIDENCE	ALPHA	AXIAL	REL
NO							LBM/SEC	KG/SEC		IN DEG	IN DEG	VEL	VEL
10.	1	1.035	0.3685	1.0166	1.0251	1.0000	0.0	0.0	-0.87	-0.67	86.5	1.039	0.999
20.	2	1.037	0.3691	1.0183	1.0251	1.0000	0.0	0.0	-0.83	-1.23	88.0	1.040	0.994
30.	3	1.038	0.3696	1.0181	1.0251	1.0000	0.0	0.0	-0.78	-1.86	87.3	1.041	0.990
40.	4	1.039	0.3700	1.0179	1.0251	1.0000	0.0	0.0	-0.72	-2.58	86.6	1.042	0.984
50.	5	1.040	0.3704	1.0177	1.0251	1.0000	0.0	0.0	-0.64	-3.50	85.7	1.042	0.977
60.	6	1.042	0.3709	1.0167	1.0244	1.0000	0.0	0.0	-0.54	-4.64	84.6	1.042	0.966
70.	7	1.045	0.3720	1.0155	1.0237	1.0000	0.0	0.0	-0.39	-6.17	83.0	1.041	0.955
80.	8	1.050	0.3739	1.0119	1.0210	1.0000	0.0	0.0	-0.15	-8.55	80.6	1.040	0.934
90.	9	1.045	0.3722	0.9923	1.0000	1.0000	0.0	0.0	-0.03	-9.66	79.5	1.032	0.926
100.	10	1.019	0.3626	0.9602	0.9831	1.0000	0.0	0.0	-0.19	-8.17	81.0	1.011	0.932
110.	11	1.004	0.3572	0.9773	0.9777	1.0000	0.0	0.0	-0.42	-5.86	83.5	1.002	0.948
120.	12	0.993	0.3553	0.9772	0.9757	1.0000	0.0	0.0	-0.66	-4.82	85.2	0.994	0.961
130.	13	0.985	0.3541	0.9773	0.9743	1.0000	0.0	0.0	-0.73	-2.52	86.7	0.987	0.970
140.	14	0.979	0.3479	0.9703	0.9742	1.0000	0.0	0.0	-0.83	-1.29	87.9	0.982	0.978
150.	15	0.972	0.3457	0.9703	0.9743	1.0000	0.0	0.0	-0.90	-0.34	86.9	0.976	0.984
160.	16	0.964	0.3442	0.9800	0.9743	1.0000	0.0	0.0	-0.96	0.46	89.7	0.973	0.989
170.	17	0.960	0.3430	0.9815	0.9743	1.0000	0.0	0.0	-1.02	1.20	90.4	0.969	0.994
180.	18	0.962	0.3419	0.9810	0.9743	1.0000	0.0	0.0	-1.06	1.91	91.1	0.966	0.995
190.	19	0.968	0.3405	0.9816	0.9743	1.0000	0.0	0.0	-1.11	2.58	91.6	0.962	1.003
200.	20	0.977	0.3400	0.9819	0.9743	1.0000	0.0	0.0	-1.15	3.25	92.0	0.960	1.007
210.	21	0.986	0.3397	0.9820	0.9743	1.0000	0.0	0.0	-1.20	4.02	93.2	0.959	1.013
220.	22	0.995	0.3394	0.9821	0.9743	1.0000	0.0	0.0	-1.25	4.93	94.1	0.957	1.019
230.	23	0.995	0.3393	0.9829	0.9750	1.0000	0.0	0.0	-1.31	5.99	95.2	0.955	1.027
240.	24	0.995	0.3393	0.9839	0.9761	1.0000	0.0	0.0	-1.37	7.20	96.4	0.954	1.036
250.	25	0.998	0.3403	0.9861	0.9789	1.0000	0.0	0.0	-1.43	8.53	97.7	0.954	1.046
260.	26	0.997	0.3408	0.9873	0.9815	1.0000	0.0	0.0	-1.50	10.04	99.7	0.958	1.063
270.	27	0.998	0.3414	1.0024	1.0000	1.0000	0.0	0.0	-1.52	11.47	100.7	0.975	1.076
280.	28	0.996	0.3442	1.0183	1.0172	1.0000	0.0	0.0	-1.48	9.92	99.1	0.988	1.068
290.	29	0.997	0.3446	1.0242	1.0233	1.0000	0.0	0.0	-1.57	7.24	96.4	0.995	1.049
300.	30	1.003	0.3468	1.0236	1.0241	1.0000	0.0	0.0	-1.26	5.12	94.3	1.004	1.035
310.	31	1.009	0.3491	1.0224	1.0251	1.0000	0.0	0.0	-1.17	3.66	92.9	1.012	1.025
320.	32	1.016	0.3516	1.0221	1.0251	1.0000	0.0	0.0	-1.10	2.53	91.7	1.020	1.019
330.	33	1.022	0.3537	1.0210	1.0251	1.0000	0.0	0.0	-1.05	1.71	89.9	1.026	1.014
340.	34	1.026	0.3561	1.0204	1.0251	1.0000	0.0	0.0	-1.00	1.04	90.2	1.030	1.010
350.	35	1.030	0.3585	1.0198	1.0251	1.0000	0.0	0.0	-0.96	0.43	89.6	1.034	1.006
360.	36	1.033	0.3616	1.0191	1.0251	1.0000	0.0	0.0	-0.92	-0.13	89.1	1.037	1.002

STAGE
 RATIO

FLOW SWIRL= 0.0DEG PARTICLE SWIRL= 2.18DEG PSAVG= 6.59PSIA = 45386.PA
 PTAVG= 7.64PSIA = 49936.PA TTAVG= 514.0DEG R = 295.0DEG K VELAVG= 416.8FPS = 127.0MPS
 FVELAVG= 740.6FPS = 219.6MPS AXVELAVG= 413.4FPS = 126.0MPS U= 643.FPS = 196.MPS

THETA	SPD	VFL	W	PS	PT	TT	WRL	WFL	DF	INCIDENCE	BETA	AXIAL	REL
NO							LBM/SEC	KG/SEC		IN DEG	IN DEG	VEL	VEL
12.	1	1.025	0.3627	1.0221	1.0267	1.0000	0.013	0.006	0.437	6.00	35.7	1.023	1.006
20.	2	1.024	0.3632	1.0218	1.0267	1.0000	0.015	0.006	0.437	5.96	35.7	1.024	1.007
30.	3	1.025	0.3633	1.0217	1.0267	1.0000	0.017	0.006	0.436	5.94	35.8	1.025	1.007
40.	4	1.025	0.3636	1.0216	1.0267	1.0000	0.018	0.006	0.436	5.93	35.8	1.025	1.007
50.	5	1.025	0.3638	1.0216	1.0266	1.0000	0.017	0.006	0.437	5.94	35.8	1.025	1.007
60.	6	1.025	0.3634	1.0216	1.0259	1.0000	0.018	0.006	0.436	5.95	35.7	1.025	1.007
70.	7	1.024	0.3631	1.0213	1.0251	1.0000	0.015	0.006	0.436	5.97	35.7	1.024	1.007
80.	8	1.025	0.3628	1.0216	1.0222	1.0000	0.012	0.006	0.439	5.99	35.7	1.023	1.006
90.	9	1.025	0.3632	1.0216	1.0215	1.0000	0.009	0.006	0.442	5.96	35.7	1.025	1.007
100.	10	1.024	0.3622	1.0216	0.9823	1.0000	-0.010	-0.005	0.444	5.97	35.7	1.024	1.007
110.	11	1.020	0.3617	0.9776	0.9764	1.0000	-0.013	-0.006	0.447	6.09	35.6	1.020	1.005
120.	12	1.014	0.3603	0.9715	0.9742	1.0000	-0.014	-0.006	0.450	6.26	35.4	1.014	1.004
130.	13	1.009	0.3577	0.9711	0.9726	1.0000	-0.015	-0.007	0.453	6.43	35.3	1.009	1.002
140.	14	1.003	0.3571	0.9721	0.9726	1.0000	-0.015	-0.007	0.456	6.58	35.1	1.003	1.001
150.	15	0.999	0.3573	0.9727	0.9724	1.0000	-0.016	-0.007	0.459	6.71	35.0	0.999	1.000
160.	16	0.995	0.3571	0.9725	0.9724	1.0000	-0.016	-0.007	0.462	6.83	34.9	0.995	0.999
170.	17	0.991	0.3574	0.9741	0.9724	1.0000	-0.015	-0.007	0.464	6.94	34.8	0.991	0.998
180.	18	0.988	0.3569	0.9747	0.9723	1.0000	-0.015	-0.007	0.466	7.03	34.7	0.988	0.997
190.	19	0.985	0.3579	0.9751	0.9721	1.0000	-0.016	-0.007	0.469	7.13	34.6	0.985	0.996
200.	20	0.981	0.3566	0.9754	0.9723	1.0000	-0.015	-0.007	0.471	7.23	34.5	0.981	0.995
210.	21	0.978	0.3564	0.9767	0.9725	1.0000	-0.014	-0.007	0.473	7.33	34.4	0.978	0.994
220.	22	0.975	0.3561	0.9776	0.9726	1.0000	-0.013	-0.006	0.476	7.43	34.3	0.975	0.993
230.	23	0.971	0.3567	0.9790	0.9736	1.0000	-0.013	-0.006	0.478	7.53	34.2	0.971	0.992
240.	24	0.968	0.35614	0.9808	0.9747	1.0000	-0.012	-0.005	0.480	7.63	34.1	0.968	0.991
250.	25	0.965	0.3563	0.9844	0.9777	1.0000	-0.010	-0.004	0.481	7.72	34.0	0.965	0.991
260.	26	0.963	0.3596	0.9891	0.9810	1.0000	-0.006	-0.003	0.482	7.78	33.9	0.963	0.990
270.	27	0.963	0.3596	1.0061	1.0069	1.0000	0.007	0.003	0.477	7.77	33.9	0.963	0.990
280.	28	0.967	0.3611	1.0249	1.0183	1.0000	0.014	0.007	0.471	7.65	34.0	0.967	0.991
290.	29	0.975	0.3644	1.0296	1.0247	1.0000	0.015	0.007	0.466	7.40	34.3	0.975	0.993
300.	30	0.986	0.3684	1.0367	1.0253	1.0000	0.015	0.007	0.460	7.09	34.6	0.986	0.996
310.	31	0.998	0.3720	1.0424	1.0263	1.0000	0.014	0.006	0.454	6.82	34.9	0.998	0.999
320.	32	1.003	0.3756	1.0459	1.0264	1.0000	0.014	0.006	0.449	6.59	35.1	1.003	1.001
330.	33	1.009	0.3776	1.0474	1.0265	1.0000	0.014	0.006	0.445	6.40	35.3	1.009	1.002
340.	34	1.014	0.3793	1.0438	1.0268	1.0000	0.013	0.006	0.442	6.26	35.4	1.014	1.004
350.	35	1.021	0.3796	1.0430	1.0266	1.0000	0.013	0.006	0.440	6.14	35.6	1.021	1.005
360.	36	1.021	0.3819	1.0425	1.0267	1.0000	0.013	0.006	0.436	6.06	35.6	1.021	1.006

APPENDIX B (Cont'd)

STATOP FLOW SWIRL = 0.649 DEG PARTICLE SWIRL = 10.62 DEG PSAVG = 7.53PSJA = 50552.PA
 TTAVG = 0.73PSJA = 60225.PA TTAVG = 566.2 DEG R = 311.2 DEG K VELAVG = 573.2 FPS = 174.7 MPS
 RVAVG = 561.4 FPS = 153.0 MPS AXVELAVG = 429.4 FPS = 131.0 MPS U = 638. FPS = 195. MPS

TRPTA	SEC NO	VEL	MN	PS	PT	TT	WBL LBM/SEC	WEL KG/SEC	DF	INCIDENCE IN DEG	PETA IN DEG	AXIAL VEL	REL VEL
144	1	1.008	0.5105	1.0180	1.0218	0.9997	0.0	0.0	0.411	-9.41	49.6	1.026	1.026
144	2	1.008	0.5105	1.0180	1.0220	0.9997	0.0	0.0	0.410	-9.46	49.9	1.027	1.027
144	3	1.007	0.5104	1.0184	1.0227	0.9998	0.0	0.0	0.410	-9.46	49.9	1.027	1.027
144	4	1.007	0.5103	1.0186	1.0224	0.9999	0.0	0.0	0.410	-9.48	49.9	1.027	1.027
144	5	1.007	0.5100	1.0203	1.0228	1.0000	0.0	0.0	0.410	-9.45	49.9	1.027	1.027
144	6	1.006	0.5097	1.0200	1.0223	0.9999	0.0	0.0	0.411	-9.41	49.8	1.026	1.026
144	7	1.006	0.5095	1.0197	1.0219	0.9998	0.0	0.0	0.412	-9.36	49.8	1.025	1.025
144	8	1.005	0.5092	1.0171	1.0191	0.9993	0.0	0.0	0.413	-9.30	49.7	1.023	1.023
144	9	1.002	0.5088	1.0146	0.9963	0.9939	0.0	0.0	0.415	-9.17	49.6	1.021	1.021
144	10	0.999	0.5077	0.9765	0.9775	0.9917	0.0	0.0	0.418	-9.01	49.4	1.017	1.017
144	11	0.999	0.5065	0.9752	0.9752	0.9962	0.0	0.0	0.421	-8.85	49.3	1.014	1.014
144	12	0.998	0.5056	0.9762	0.9757	0.9997	0.0	0.0	0.425	-8.63	49.0	1.009	1.009
144	13	0.998	0.5049	0.9761	0.9751	1.0009	0.0	0.0	0.429	-8.38	48.6	1.004	1.004
144	14	0.997	0.5045	0.9770	0.9757	1.0008	0.0	0.0	0.433	-8.16	48.6	0.999	0.999
144	15	0.996	0.5034	0.9775	0.9760	1.0009	0.0	0.0	0.437	-7.95	48.3	0.995	0.995
144	16	0.996	0.5037	0.9780	0.9762	1.0008	0.0	0.0	0.440	-7.76	48.2	0.991	0.991
144	17	0.995	0.5034	0.9783	0.9764	1.0007	0.0	0.0	0.443	-7.60	48.0	0.988	0.988
144	18	0.994	0.5031	0.9788	0.9764	1.0007	0.0	0.0	0.446	-7.45	47.9	0.985	0.985
144	19	0.992	0.5027	0.9791	0.9766	1.0006	0.0	0.0	0.448	-7.30	47.7	0.981	0.981
204	20	0.992	0.5022	0.9800	0.9772	1.0007	0.0	0.0	0.451	-7.14	47.5	0.976	0.976
214	21	0.992	0.5018	0.9807	0.9777	1.0007	0.0	0.0	0.454	-6.99	47.4	0.975	0.975
224	22	0.991	0.5013	0.9816	0.9783	1.0007	0.0	0.0	0.457	-6.82	47.2	0.972	0.972
234	23	0.991	0.5009	0.9832	0.9798	1.0005	0.0	0.0	0.460	-6.66	47.1	0.966	0.966
244	24	0.990	0.5005	0.9850	0.9812	1.0011	0.0	0.0	0.462	-6.51	46.9	0.965	0.965
254	25	0.990	0.5001	0.9863	0.9844	1.0016	0.0	0.0	0.464	-6.41	46.8	0.963	0.963
264	26	0.990	0.5001	0.9872	0.9875	1.0019	0.0	0.0	0.465	-6.36	46.8	0.962	0.962
274	27	0.990	0.5000	0.9895	1.0070	1.0060	0.0	0.0	0.466	-6.33	47.1	0.961	0.961
284	28	1.001	0.5051	1.0231	1.0222	1.0075	0.0	0.0	0.453	-7.03	47.4	0.976	0.976
294	29	1.007	0.5071	1.0235	1.0239	1.0073	0.0	0.0	0.446	-7.41	47.8	0.984	0.984
304	30	1.003	0.5084	1.0199	1.0213	0.9990	0.0	0.0	0.439	-7.82	48.2	0.992	0.992
314	31	1.005	0.5053	1.0194	1.0214	0.9982	0.0	0.0	0.432	-8.22	48.6	1.001	1.001
324	32	1.006	0.5098	1.0188	1.0212	0.9985	0.0	0.0	0.426	-8.56	49.0	1.006	1.006
334	33	1.007	0.5101	1.0185	1.0211	0.9986	0.0	0.0	0.421	-8.84	49.2	1.014	1.014
344	34	1.007	0.5104	1.0184	1.0211	0.9986	0.0	0.0	0.417	-9.08	49.5	1.018	1.018
354	35	1.000	0.5105	1.0184	1.0213	0.9997	0.0	0.0	0.414	-9.22	49.6	1.022	1.022
4	36	1.008	0.5106	1.0186	1.0215	0.9994	0.0	0.0	0.412	-9.34	49.7	1.024	1.024

STATOP FLOW SWIRL = 1.400 DEG PARTICLE SWIRL = 24.63 DEG PSAVG = 7.66PSJA = 54321.PA
 TTAVG = 0.73PSJA = 60183.PA TTAVG = 566.2 DEG R = 311.2 DEG K VELAVG = 446.6 FPS = 134.3 MPS
 RVAVG = 571.4 FPS = 174.7 MPS AXVELAVG = 435.7 FPS = 132.4 MPS U = 635. FPS = 194. MPS

TRPTA	SEC NO	VEL	MN	PS	PT	TT	WBL LBM/SEC	WEL KG/SEC	DF	INCIDENCE IN DEG	PETA IN DEG	AXIAL VEL	REL VEL
16	1	1.026	0.5957	1.0178	1.0234	0.9994	0.0	0.0	0.407	0.90	36.2	1.026	1.026
26	2	1.027	0.5960	1.0181	1.0239	0.9997	0.0	0.0	0.407	0.87	36.2	1.027	1.027
36	3	1.028	0.5962	1.0182	1.0242	0.9998	0.0	0.0	0.407	0.86	36.2	1.028	1.028
46	4	1.028	0.5962	1.0186	1.0245	0.9999	0.0	0.0	0.407	0.86	36.2	1.028	1.028
56	5	1.027	0.5955	1.0192	1.0249	1.0000	0.0	0.0	0.408	0.87	36.2	1.027	1.027
66	6	1.026	0.5956	1.0189	1.0245	0.9999	0.0	0.0	0.408	0.90	36.2	1.026	1.026
76	7	1.025	0.5952	1.0186	1.0240	0.9999	0.0	0.0	0.409	0.93	36.2	1.025	1.025
86	8	1.024	0.5947	1.0181	1.0231	0.9995	0.0	0.0	0.411	0.98	36.1	1.024	1.024
96	9	1.021	0.5948	0.9934	0.9984	0.9929	0.0	0.0	0.414	1.06	36.0	1.021	1.021
106	10	1.021	0.5939	0.9754	0.9769	0.9917	0.0	0.0	0.419	1.12	37.9	1.016	1.016
116	11	1.021	0.5935	0.9744	0.9776	0.9962	0.0	0.0	0.423	1.27	37.8	1.014	1.014
126	12	1.025	0.5985	0.9751	0.9776	0.9997	0.0	0.0	0.426	1.42	37.7	1.009	1.009
136	13	1.024	0.5986	0.9754	0.9766	1.0004	0.0	0.0	0.429	1.58	37.5	1.004	1.004
146	14	0.994	0.5966	0.9771	0.9767	1.0008	0.0	0.0	0.431	1.73	37.4	0.999	0.999
156	15	0.995	0.5969	0.9778	0.9765	1.0009	0.0	0.0	0.434	1.87	37.2	0.995	0.995
166	16	0.994	0.5961	0.9784	0.9764	1.0008	0.0	0.0	0.436	1.99	37.1	0.991	0.991
176	17	0.997	0.5960	0.9785	0.9762	1.0007	0.0	0.0	0.436	2.10	37.0	0.987	0.987
186	18	0.994	0.5977	0.9795	0.9761	1.0007	0.0	0.0	0.441	2.20	36.8	0.984	0.984
196	19	0.993	0.5977	0.9794	0.9754	1.0006	0.0	0.0	0.443	2.30	36.8	0.981	0.981
206	20	0.997	0.5971	0.9810	0.9762	1.0007	0.0	0.0	0.445	2.41	36.7	0.977	0.977
216	21	0.994	0.5974	0.9819	0.9765	1.0007	0.0	0.0	0.448	2.51	36.6	0.974	0.974
226	22	0.997	0.5973	0.9829	0.9774	1.0007	0.0	0.0	0.451	2.62	36.5	0.971	0.971
236	23	0.997	0.5972	0.9846	0.9779	1.0009	0.0	0.0	0.452	2.72	36.4	0.967	0.967
246	24	0.994	0.5979	0.9844	0.9791	1.0011	0.0	0.0	0.454	2.81	36.3	0.964	0.964
256	25	0.992	0.5975	0.9864	0.9811	1.0016	0.0	0.0	0.455	2.88	36.2	0.962	0.962
266	26	0.992	0.5976	0.9862	0.9805	1.0014	0.0	0.0	0.455	2.90	36.2	0.962	0.962
276	27	0.997	0.5971	0.9870	0.9805	1.0016	0.0	0.0	0.456	2.93	36.4	0.967	0.967
286	28	0.997	0.5974	0.9874	0.9816	1.0016	0.0	0.0	0.456	2.97	36.6	0.975	0.975
296	29	0.997	0.5971	0.9874	0.9820	1.0016	0.0	0.0	0.452	2.92	36.9	0.984	0.984
306	30	0.995	0.5982	0.9874	0.9818	0.9992	0.0	0.0	0.427	1.95	37.2	0.992	0.992
316	31	0.995	0.5982	0.9874	0.9818	0.9992	0.0	0.0	0.423	1.66	37.4	1.001	1.001
326	32	1.001	0.5987	0.9874	0.9818	0.9992	0.0	0.0	0.423	1.66	37.4	1.001	1.001
336	33	1.001	0.5987	0.9874	0.9818	0.9992	0.0	0.0	0.423	1.66	37.4	1.001	1.001
346	34	1.001	0.5987	0.9874	0.9818	0.9992	0.0	0.0	0.423	1.66	37.4	1.001	1.001
356	35	1.001	0.5987	0.9874	0.9818	0.9992	0.0	0.0	0.423	1.66	37.4	1.001	1.001

02

APPENDIX B (Cont'd)

STATC

FLOW SWIRL = 0.000DEG
 PTA VCG = 1.000PSIA = 72364.4PA
 FVELAVG = 512.0FPS = 156.1MPS
 PARTICLE SWIRL = 35.43DEG
 TTA VCG = 591.4DEG R = 328.6DEG K
 AXVELAVG = 427.6FPS = 131.4MPS
 PSAVG = 9.00PSIA = 62042.4PA
 VELA VCG = 453.0FPS = 148.6MPS
 U = 652.0FPS = 193.1MPS

THETA	SEC	VEL	MN	PS	PT	TT	WBL	WEL	DF	INCIDENCE	ETA	AXIAL	REL
DEG	MC						LBM/SEC	KG/SEC		IN DEG	IN DEG	VEL	VEL
152	1	1.008	0.4750	1.0137	1.0169	0.9969	0.0	0.0	0.393	-11.70	52.1	1.026	1.028
20	1	1.008	0.4770	1.0143	1.0174	0.9971	0.0	0.0	0.392	-11.74	52.1	1.029	1.029
20	2	1.008	0.4769	1.0148	1.0176	0.9972	0.0	0.0	0.392	-11.75	52.2	1.029	1.029
4	4	1.008	0.4787	1.0155	1.0185	0.9974	0.0	0.0	0.352	-11.74	52.1	1.029	1.029
4	5	1.008	0.4784	1.0166	1.0194	0.9977	0.0	0.0	0.395	-11.69	52.1	1.028	1.028
64	6	1.007	0.4772	1.0167	1.0192	0.9977	0.0	0.0	0.394	-11.63	52.0	1.027	1.027
72	7	1.007	0.4776	1.0168	1.0192	0.9977	0.0	0.0	0.396	-11.56	52.0	1.025	1.025
84	8	1.006	0.4777	1.0167	1.0170	0.9971	0.0	0.0	0.296	-11.47	51.9	1.024	1.024
98	9	1.004	0.4780	0.9958	0.9967	0.9915	0.0	0.0	0.403	-11.25	51.7	1.019	1.019
108	10	1.000	0.4771	0.9766	0.9786	0.9778	0.0	0.0	0.410	-10.94	51.3	1.013	1.013
118	11	0.997	0.4747	0.9764	0.9766	0.9928	0.0	0.0	0.417	-10.64	51.0	1.007	1.007
128	12	0.994	0.4757	0.9799	0.9785	0.9960	0.0	0.0	0.421	-10.43	50.6	1.003	1.003
138	13	0.992	0.4728	0.9704	0.9764	0.9996	0.0	0.0	0.426	-10.24	50.6	0.999	0.999
148	14	0.988	0.4728	0.9817	0.9803	1.0012	0.0	0.0	0.420	-10.04	50.4	0.995	0.995
158	15	0.989	0.4714	0.9822	0.9806	1.0019	0.0	0.0	0.435	-9.84	50.2	0.991	0.991
168	16	0.985	0.4711	0.9829	0.9810	1.0024	0.0	0.0	0.439	-9.67	50.1	0.988	0.988
178	17	0.984	0.4707	0.9831	0.9811	1.0025	0.0	0.0	0.442	-9.51	49.9	0.985	0.985
188	18	0.984	0.4703	0.9827	0.9812	1.0027	0.0	0.0	0.446	-9.36	49.8	0.982	0.982
198	19	0.985	0.4699	0.9843	0.9816	1.0029	0.0	0.0	0.449	-9.20	49.6	0.979	0.979
208	20	0.982	0.4685	0.9815	0.9826	1.0035	0.0	0.0	0.453	-9.03	49.4	0.975	0.975
218	21	0.981	0.4689	0.9866	0.9832	1.0036	0.0	0.0	0.457	-8.87	49.3	0.972	0.972
228	22	0.980	0.4684	0.9877	0.9841	1.0040	0.0	0.0	0.460	-8.70	49.1	0.969	0.969
238	23	0.980	0.4679	0.9891	0.9852	1.0043	0.0	0.0	0.464	-8.55	48.9	0.966	0.966
248	24	0.979	0.4677	0.9905	0.9862	1.0046	0.0	0.0	0.468	-8.42	48.8	0.964	0.964
258	25	0.980	0.4676	0.9927	0.9886	1.0052	0.0	0.0	0.468	-8.26	48.6	0.962	0.962
268	26	0.980	0.4676	0.9948	0.9906	1.0055	0.0	0.0	0.468	-8.16	48.6	0.962	0.962
278	27	0.980	0.4683	1.0095	1.0063	1.0092	0.0	0.0	0.456	-8.60	49.2	0.971	0.971
288	28	1.000	0.4712	1.0207	1.0188	1.0111	0.0	0.0	0.446	-9.25	49.7	0.982	0.982
298	29	1.004	0.4741	1.0205	1.0209	1.0083	0.0	0.0	0.434	-9.87	50.3	0.992	0.992
308	30	1.005	0.4772	1.0181	1.0174	1.0022	0.0	0.0	0.426	-10.24	50.6	0.999	0.999
318	31	1.005	0.4772	1.0146	1.0165	0.9982	0.0	0.0	0.419	-10.55	50.9	1.005	1.005
328	32	1.006	0.4778	1.0132	1.0157	0.9967	0.0	0.0	0.412	-10.86	51.3	1.011	1.011
338	33	1.007	0.4784	1.0127	1.0154	0.9965	0.0	0.0	0.405	-11.15	51.5	1.017	1.017
348	34	1.008	0.4787	1.0127	1.0155	0.9964	0.0	0.0	0.401	-11.36	51.8	1.021	1.021
358	35	1.008	0.4791	1.0127	1.0158	0.9965	0.0	0.0	0.397	-11.52	51.9	1.025	1.025
8	36	1.008	0.4791	1.0121	1.0167	0.9967	0.0	0.0	0.394	-11.64	52.0	1.027	1.027

STATC
ROTFC

FLOW SWIRL = 12.01DEG
 PTA VCG = 10.27PSIA = 70841.4PA
 FVELAVG = 750.0FPS = 228.0MPS
 PARTICLE SWIRL = 39.11DEG
 TTA VCG = 591.4DEG R = 328.6DEG K
 AXVELAVG = 442.6FPS = 134.9MPS
 PSAVG = 9.31PSIA = 64219.4PA
 VELA VCG = 443.1FPS = 135.1MPS
 U = 626.0FPS = 191.1MPS

THETA	SEC	VEL	MN	PS	PT	TT	WBL	WEL	DF	INCIDENCE	ETA	AXIAL	REL
DEG	MC						LBM/SEC	KG/SEC		IN DEG	IN DEG	VEL	VEL
27	1	1.006	0.3923	1.0027	1.0107	0.9969	0.0	0.0	0.538	-2.10	37.2	1.038	1.013
35	2	1.009	0.3927	1.0029	1.0111	0.9971	0.0	0.0	0.537	-2.13	37.2	1.039	1.013
42	3	1.000	0.3928	1.0032	1.0115	0.9972	0.0	0.0	0.537	-2.14	37.2	1.040	1.013
51	4	1.009	0.3926	1.0040	1.0122	0.9974	0.0	0.0	0.538	-2.13	37.2	1.039	1.013
61	5	1.008	0.3926	1.0055	1.0124	0.9977	0.0	0.0	0.559	-2.09	37.2	1.038	1.012
72	6	1.006	0.3914	1.0060	1.0136	0.9977	0.0	0.0	0.540	-2.05	37.1	1.036	1.012
84	7	1.005	0.3907	1.0063	1.0138	0.9977	0.0	0.0	0.541	-2.00	37.1	1.035	1.011
98	8	1.002	0.3898	1.0073	1.0129	0.9971	0.0	0.0	0.545	-1.92	37.0	1.032	1.010
108	9	1.002	0.3887	0.9860	0.9919	0.9915	0.0	0.0	0.548	-1.76	36.9	1.026	1.006
122	10	1.001	0.3884	0.9734	0.9782	0.9876	0.0	0.0	0.555	-1.53	36.6	1.018	1.006
138	11	1.001	0.3884	0.9734	0.9789	0.9906	0.0	0.0	0.561	-1.36	36.4	1.016	1.003
142	12	1.004	0.3791	0.9777	0.9787	0.9966	0.0	0.0	0.565	-1.14	36.2	1.004	1.001
152	13	0.993	0.3764	0.9805	0.9802	0.9996	0.0	0.0	0.568	-1.00	36.1	0.995	0.999
162	14	0.983	0.3740	0.9824	0.9819	1.0012	0.0	0.0	0.569	-0.84	35.9	0.993	0.998
172	14	0.983	0.3740	0.9824	0.9830	1.0024	0.0	0.0	0.571	-0.70	35.8	0.988	0.986
182	15	0.983	0.3719	0.9856	0.9829	1.0019	0.0	0.0	0.574	-0.57	35.7	0.983	0.995
192	16	0.975	0.3684	0.9889	0.9845	1.0025	0.0	0.0	0.576	-0.45	35.5	0.979	0.993
202	17	0.975	0.3666	0.9907	0.9855	1.0027	0.0	0.0	0.578	-0.33	35.4	0.975	0.992
212	18	0.971	0.3651	0.9926	0.9865	1.0029	0.0	0.0	0.581	-0.21	35.3	0.971	0.991
222	19	0.967	0.3633	0.9951	0.9882	1.0033	0.0	0.0	0.584	-0.08	35.2	0.967	0.989
232	20	0.962	0.3617	0.9975	0.9896	1.0036	0.0	0.0	0.586	0.04	35.1	0.962	0.988
242	21	0.958	0.3599	0.9997	0.9911	1.0040	0.0	0.0	0.588	0.16	34.9	0.958	0.986
252	22	0.954	0.3582	1.0023	0.9929	1.0043	0.0	0.0	0.592	0.26	34.8	0.954	0.985
262	23	0.949	0.3571	1.0045	0.9945	1.0046	0.0	0.0	0.595	0.37	34.7	0.951	0.984
272	24	0.949	0.3562	1.0068	0.9970	1.0052	0.0	0.0	0.594	0.42	34.7	0.949	0.984
282	25	0.949	0.3562	1.0084	0.9991	1.0055	0.0	0.0	0.593	0.42	34.7	0.949	0.984
292	26	0.949	0.3589	1.0112	1.0128	1.0092	0.0	0.0	0.587	0.09	35.0	0.941	0.987
302	27	0.949	0.3589	1.0112	1.0122	1.0110	0.0	0.0	0.571	-0.32	35.4	0.975	0.992
312	28	0.949	0.3575	1.0172	1.0121	1.0083	0.0	0.0	0.561	-0.71	35.6	0.988	0.996
322	29	0.949	0.3575	1.0172	1.0116	1.0022	0.0	0.0	0.555	-0.98	36.1	0.998	0.999
332	30	0.949	0.3575	1.0172	1.0115	0.9987	0.0	0.0	0.551	-1.22	36.4	1.007	1.002
342	31	0.949	0.3583	1.0203	1.0127	0.9967	0.0	0.0	0.548	-1.46	36.6	1.015	1.005
352	32	0.949	0.3583	1.0203	1.0111	0.9965	0.0	0.0	0.544	-1.68	36.8	1.023	1.007
362	33	0.949	0.3583	1.0203	1.0104	0.9964	0.0	0.0	0.541	-1.84	36.9	1.029	1.009
372	34	0.949	0.3583	1.0203	1.0102	0.9965	0.0	0.0	0.539	-1.98	37.1	1.033	1.011
382	35	0.949	0.3583	1.0203	1.0102	0.9967	0.0	0.0	0.535	-2.05	37.2	1.036	1.012

REPRODUCIBILITY OF THE ORIGINAL PAGE IS POOR

APPENDIX B (Cont'd)

STAGE 5
RTOP

FLOW SWIRL = 19.10FC PARTICLE SWIRL = 64.57DFG PSAVG = 11.04PSIA = 15022.PA
 PTAVG = 13.83PSIA = 95322.PA TTAVG = 655.8DFC R = 364.3DFC K VELAVG = 552.1FPS = 168.3MPS
 FVELAVG = 541.2FPS = 165.0MPS AXVELAVG = 456.2FPS = 139.0MPS U = 602.1FPS = 183.1MPS

THETA	SEC	VEL	MM	PS	PT	TT	WBL	WBL	DF	INCIDENCE	ALPHA	AXIAL	REL
	NO						LBM/SEC	KG/SEC		IN DEG	IN DEG	VEL	VEL
29.	1	1.013	0.4564	1.0038	1.0084	0.9932	0.0	0.0	0.269	1.27	57.4	1.033	1.033
30.	2	1.013	0.4564	1.0047	1.0094	0.9934	0.0	0.0	0.269	1.25	57.5	1.033	1.033
40.	2	1.013	0.4564	1.0055	1.0101	0.9926	0.0	0.0	0.269	1.24	57.5	1.034	1.034
50.	4	1.013	0.4561	1.0077	1.0117	0.9941	0.0	0.0	0.269	1.28	57.4	1.033	1.033
60.	5	1.012	0.4555	1.0098	1.0139	0.9947	0.0	0.0	0.271	1.37	57.3	1.031	1.031
70.	6	1.011	0.4553	1.0105	1.0145	0.9949	0.0	0.0	0.272	1.43	57.3	1.036	1.036
80.	7	1.011	0.4551	1.0110	1.0149	0.9951	0.0	0.0	0.273	1.47	57.2	1.029	1.029
90.	8	1.010	0.4548	1.0101	1.0137	0.9948	0.0	0.0	0.274	1.55	57.1	1.027	1.027
100.	9	1.006	0.4545	0.9943	0.9977	0.9905	0.0	0.0	0.279	1.84	56.9	1.022	1.022
110.	10	1.003	0.4531	0.9831	0.9856	0.9875	0.0	0.0	0.287	2.34	56.4	1.012	1.012
120.	11	1.000	0.4517	0.9734	0.9849	0.9884	0.0	0.0	0.294	2.76	55.9	1.004	1.004
130.	12	0.997	0.4495	0.9645	0.9850	0.9907	0.0	0.0	0.299	3.07	55.6	0.998	0.998
140.	13	0.995	0.4479	0.9554	0.9849	0.9944	0.0	0.0	0.302	3.27	55.4	0.994	0.994
150.	14	0.995	0.4468	0.9676	0.9842	0.9919	0.0	0.0	0.305	3.42	55.3	0.991	0.991
160.	15	0.994	0.4453	0.9894	0.9873	1.0022	0.0	0.0	0.307	3.59	55.1	0.988	0.988
170.	16	0.993	0.4445	0.9904	0.9878	1.0039	0.0	0.0	0.310	3.77	54.9	0.984	0.984
180.	17	0.992	0.4438	0.9910	0.9880	1.0048	0.0	0.0	0.313	3.95	54.8	0.981	0.981
190.	18	0.990	0.4429	0.9927	0.9891	1.0056	0.0	0.0	0.317	4.17	54.5	0.977	0.977
200.	19	0.989	0.4420	0.9941	0.9901	1.0062	0.0	0.0	0.321	4.39	54.3	0.972	0.972
210.	20	0.987	0.4411	0.9963	0.9917	1.0071	0.0	0.0	0.324	4.62	54.1	0.968	0.968
220.	21	0.986	0.4404	0.9978	0.9922	1.0077	0.0	0.0	0.328	4.81	53.9	0.964	0.964
230.	22	0.984	0.4395	0.9998	0.9943	1.0085	0.0	0.0	0.331	5.03	53.7	0.960	0.960
240.	23	0.983	0.4389	1.0014	0.9955	1.0092	0.0	0.0	0.334	5.19	53.5	0.957	0.957
250.	24	0.983	0.4385	1.0025	0.9965	1.0097	0.0	0.0	0.336	5.32	53.4	0.955	0.955
260.	25	0.983	0.4384	1.0037	0.9975	1.0101	0.0	0.0	0.337	5.35	53.3	0.954	0.954
270.	26	0.983	0.4384	1.0044	0.9982	1.0103	0.0	0.0	0.336	5.31	53.4	0.954	0.954
280.	27	0.981	0.4424	1.0060	1.0021	1.0106	0.0	0.0	0.320	4.40	54.3	0.972	0.972
290.	28	0.987	0.4449	1.0117	1.0093	1.0112	0.0	0.0	0.307	3.62	55.1	0.987	0.987
300.	29	1.002	0.4476	1.0100	1.0093	1.0094	0.0	0.0	0.296	2.96	55.7	1.000	1.000
310.	30	1.005	0.4467	1.0077	1.0082	1.0065	0.0	0.0	0.289	2.51	56.2	1.009	1.009
320.	31	1.008	0.4517	1.0069	1.0067	1.0026	0.0	0.0	0.284	2.20	56.5	1.015	1.015
330.	32	1.004	0.4525	1.0046	1.0074	0.9977	0.0	0.0	0.281	1.99	56.7	1.019	1.019
340.	33	1.010	0.4547	1.0027	1.0063	0.9942	0.0	0.0	0.278	1.79	56.9	1.023	1.023
350.	34	1.011	0.4556	1.0018	1.0059	0.9926	0.0	0.0	0.275	1.59	57.1	1.027	1.027
360.	35	1.012	0.4561	1.0015	1.0062	0.9927	0.0	0.0	0.272	1.44	57.3	1.030	1.030
370.	36	1.013	0.4564	1.0023	1.0070	0.9928	0.0	0.0	0.270	1.32	57.4	1.032	1.032

STAGE 5
RTOP

FLOW SWIRL = 22.30DFG PARTICLE SWIRL = 67.81DFG PSAVG = 12.70PSIA = 87582.PA
 PTAVG = 14.14PSIA = 96770.PA TTAVG = 655.8DFC R = 364.3DFC K VELAVG = 470.3FPS = 143.4MPS
 FVELAVG = 468.2FPS = 141.0MPS AXVELAVG = 467.7FPS = 141.0MPS U = 594.4FPS = 181.1MPS

THETA	SEC	VEL	MM	PS	PT	TT	WBL	WBL	DF	INCIDENCE	BETA	AXIAL	REL
	NO						LBM/SEC	KG/SEC		IN DEG	IN DEG	VEL	VEL
38.	1	1.004	0.3940	1.0024	1.0100	0.9922	0.0	0.0	0.406	0.67	43.3	1.034	1.012
40.	2	1.004	0.3950	1.0033	1.0110	0.9934	0.0	0.0	0.406	0.66	43.3	1.034	1.012
50.	4	1.005	0.3951	1.0041	1.0118	0.9936	0.0	0.0	0.405	0.65	43.4	1.033	1.013
60.	4	1.004	0.3947	1.0058	1.0133	0.9941	0.0	0.0	0.406	0.68	43.3	1.034	1.012
70.	6	1.007	0.3938	1.0084	1.0155	0.9947	0.0	0.0	0.408	0.73	43.3	1.032	1.012
80.	6	1.001	0.3932	1.0092	1.0160	0.9949	0.0	0.0	0.408	0.77	43.2	1.031	1.011
90.	7	1.000	0.3925	1.0098	1.0163	0.9951	0.0	0.0	0.409	0.81	43.2	1.030	1.011
100.	8	1.006	0.3923	1.0089	1.0157	0.9948	0.0	0.0	0.410	0.86	43.1	1.028	1.010
110.	9	1.002	0.3907	0.9957	0.9991	0.9955	0.0	0.0	0.416	1.06	42.9	1.022	1.008
120.	10	1.002	0.3907	0.9933	0.9886	0.9875	0.0	0.0	0.424	1.40	42.6	1.012	1.004
130.	11	1.003	0.3857	0.9840	0.9857	0.9874	0.0	0.0	0.430	1.66	42.3	1.003	1.001
140.	12	0.997	0.3809	0.9753	0.9855	0.9907	0.0	0.0	0.435	1.88	42.1	0.997	0.999
150.	13	0.993	0.3766	0.9662	0.9853	0.9944	0.0	0.0	0.436	2.01	42.0	0.993	0.997
160.	14	0.990	0.3767	0.9882	0.9863	0.9949	0.0	0.0	0.439	2.10	41.9	0.990	0.996
170.	15	0.987	0.3740	0.9900	0.9871	1.0022	0.0	0.0	0.441	2.21	41.6	0.987	0.995
180.	16	0.984	0.3731	0.9911	0.9874	1.0039	0.0	0.0	0.443	2.33	41.7	0.984	0.994
190.	17	0.980	0.3716	0.9910	0.9873	1.0048	0.0	0.0	0.445	2.44	41.6	0.980	0.993
200.	18	0.978	0.3698	0.9836	0.9882	1.0056	0.0	0.0	0.446	2.59	41.4	0.976	0.991
210.	19	0.972	0.3680	0.9852	0.9889	1.0062	0.0	0.0	0.450	2.73	41.3	0.972	0.990
220.	20	0.967	0.3662	0.9875	0.9902	1.0071	0.0	0.0	0.453	2.88	41.1	0.967	0.988
230.	21	0.964	0.3646	0.9891	0.9911	1.0077	0.0	0.0	0.455	3.01	41.0	0.964	0.987
240.	22	0.964	0.3629	1.0012	0.9924	1.0085	0.0	0.0	0.458	3.15	40.9	0.960	0.986
250.	23	0.964	0.3616	1.0020	0.9933	1.0092	0.0	0.0	0.460	3.26	40.7	0.956	0.984
260.	24	0.964	0.3605	1.0040	0.9934	1.0097	0.0	0.0	0.461	3.34	40.7	0.954	0.984
270.	25	0.963	0.3602	1.0053	0.9950	1.0101	0.0	0.0	0.461	3.36	40.6	0.953	0.983
280.	26	0.964	0.3605	1.0059	0.9958	1.0102	0.0	0.0	0.460	3.33	40.7	0.954	0.984
290.	27	0.962	0.3673	1.0044	1.0031	1.0106	0.0	0.0	0.448	2.73	41.3	0.972	0.990
300.	28	0.967	0.3731	1.0118	1.0079	1.0112	0.0	0.0	0.438	2.21	41.8	0.987	0.995
310.	29	1.001	0.3764	1.0065	1.0065	1.0094	0.0	0.0	0.426	1.77	42.2	1.001	1.000
320.	30	1.009	0.3826	1.0069	1.0084	1.0068	0.0	0.0	0.420	1.48	42.5	1.009	1.003
330.	31	1.015	0.3857	1.0063	1.0087	1.0026	0.0	0.0	0.418	1.28	42.7	1.015	1.005
340.	32	1.019	0.3813	1.0037	1.0078	0.9977	0.0	0.0	0.414	1.15	42.9	1.019	1.007
350.	33	1.023	0.3905	1.0019	1.0071	0.9942	0.0	0.0	0.412	1.02	43.0	1.023	1.008
360.	34	1.027	0.3923	1.0009	1.0071	0.9928	0.0	0.0	0.410	0.89	43.1	1.027	1.010
370.	35	1.030	0.3934	1.0008	1.0077	0.9927	0.0	0.0	0.408	0.79	43.2	1.030	1.011
380.	36	1.033	0.3945	1.0011	1.0085	0.9928	0.0	0.0	0.406	0.71	43.3	1.033	1.012

APPENDIX B (Cont'd)

STATOP FLOW SWIRL = 22.49DEG PARTICLE SWIRL = 77.96DEG PSAVC = 13.96PSIA = 96237.PA
 PTAVG = 16.1PPSIA = 111584.PA TTAGV = 681.7DEG R = 378.7DEG K VELAVG = 582.5FPS = 177.5MPS
 RVFLAVG = 515.1FPS = 157.0MPS AXVELAVG = 466.4FPS = 140.3MPS U = 588.FPS = 179.MPS

THETA	SEG NO	VEL	MN	PS	PT	TT	WBL LBM/SEC	WEL KG/SEC	DF	INCIDENCE IN DEG	BETA IN DEG	AXIAL VEL	REL VEL
32.	1	1.013	0.4729	1.0044	1.0092	0.9934	0.0	0.0	0.370	2.19	53.7	1.033	1.033
42.	2	1.013	0.4729	1.0054	1.0103	0.9937	0.0	0.0	0.370	2.17	53.7	1.033	1.033
52.	3	1.013	0.4729	1.0062	1.0111	0.9939	0.0	0.0	0.369	2.16	53.7	1.033	1.033
62.	4	1.012	0.4725	1.0081	1.0127	0.9943	0.0	0.0	0.370	2.20	53.7	1.032	1.032
72.	5	1.011	0.4719	1.0109	1.0152	0.9950	0.0	0.0	0.372	2.29	53.6	1.030	1.030
82.	6	1.011	0.4717	1.0115	1.0156	0.9952	0.0	0.0	0.372	2.34	53.6	1.029	1.029
92.	7	1.011	0.4715	1.0120	1.0160	0.9953	0.0	0.0	0.373	2.38	53.5	1.028	1.028
102.	8	1.010	0.4712	1.0113	1.0150	0.9951	0.0	0.0	0.374	2.46	53.4	1.027	1.027
112.	9	1.007	0.4705	0.9974	1.0008	0.9911	0.0	0.0	0.380	2.79	53.1	1.019	1.019
122.	10	1.002	0.4687	0.9881	0.9903	0.9863	0.0	0.0	0.389	3.30	52.6	1.008	1.008
132.	11	0.998	0.4670	0.9882	0.9893	0.9888	0.0	0.0	0.395	3.69	52.2	0.999	0.999
142.	12	0.996	0.4655	0.9885	0.9887	0.9903	0.0	0.0	0.399	3.95	51.9	0.994	0.994
152.	13	0.994	0.4641	0.9884	0.9876	0.9911	0.0	0.0	0.402	4.13	51.8	0.990	0.990
162.	14	0.994	0.4627	0.9890	0.9880	0.9971	0.0	0.0	0.404	4.24	51.7	0.987	0.987
172.	15	0.993	0.4615	0.9909	0.9886	1.0000	0.0	0.0	0.406	4.35	51.5	0.985	0.985
182.	16	0.992	0.4606	0.9918	0.9890	1.0032	0.0	0.0	0.408	4.48	51.4	0.982	0.982
192.	17	0.991	0.4600	0.9923	0.9890	1.0044	0.0	0.0	0.410	4.61	51.3	0.979	0.979
202.	18	0.990	0.4591	0.9934	0.9896	1.0054	0.0	0.0	0.412	4.78	51.1	0.976	0.976
212.	19	0.989	0.4583	0.9942	0.9900	1.0060	0.0	0.0	0.415	4.95	51.0	0.972	0.972
222.	20	0.988	0.4575	0.9957	0.9909	1.0069	0.0	0.0	0.418	5.12	50.8	0.969	0.969
232.	21	0.986	0.4568	0.9965	0.9913	1.0075	0.0	0.0	0.420	5.26	50.6	0.965	0.965
242.	22	0.985	0.4560	0.9980	0.9923	1.0082	0.0	0.0	0.423	5.42	50.5	0.962	0.962
252.	23	0.984	0.4555	0.9988	0.9928	1.0089	0.0	0.0	0.425	5.54	50.4	0.959	0.959
262.	24	0.984	0.4551	0.9993	0.9930	1.0093	0.0	0.0	0.426	5.63	50.3	0.958	0.958
272.	25	0.984	0.4551	1.0000	0.9937	1.0097	0.0	0.0	0.426	5.64	50.3	0.957	0.957
282.	26	0.985	0.4554	1.0004	0.9943	1.0099	0.0	0.0	0.425	5.59	50.3	0.959	0.959
292.	27	0.993	0.4594	1.0008	0.9972	1.0097	0.0	0.0	0.412	4.75	51.2	0.976	0.976
302.	28	0.998	0.4618	1.0074	1.0052	1.0107	0.0	0.0	0.401	4.08	51.8	0.991	0.991
312.	29	1.003	0.4645	1.0042	1.0056	1.0092	0.0	0.0	0.391	3.50	52.4	1.004	1.004
322.	30	1.006	0.4664	1.0051	1.0056	1.0070	0.0	0.0	0.385	3.13	52.6	1.012	1.012
332.	31	1.008	0.4682	1.0054	1.0073	1.0070	0.0	0.0	0.381	2.86	53.0	1.018	1.018
342.	32	1.011	0.4699	1.0064	1.0072	1.0097	0.0	0.0	0.378	2.70	53.2	1.021	1.021
352.	33	1.010	0.4712	1.0078	1.0067	0.9957	0.0	0.0	0.376	2.57	53.3	1.024	1.024
362.	34	1.011	0.4721	1.0070	1.0064	0.9935	0.0	0.0	0.374	2.44	53.5	1.027	1.027
372.	35	1.012	0.4726	1.0072	1.0065	0.9929	0.0	0.0	0.372	2.32	53.6	1.030	1.030
382.	36	1.012	0.4730	1.0072	1.0076	0.9930	0.0	0.0	0.371	2.22	53.7	1.032	1.032

STATP ROTOP FLOW SWIRL = 24.00DEG PARTICLE SWIRL = 74.57DEG PSAVC = 14.51PSIA = 100050.PA
 PTAVG = 19.50PSIA = 110152.PA TTAGV = 681.7DEG R = 378.7DEG K VELAVG = 471.4FPS = 143.6MPS
 RVFLAVG = 326.5FPS = 221.4MPS AXVELAVG = 470.1FPS = 143.3MPS U = 582.FPS = 177.MPS

THETA	SEG NO	VEL	MN	PS	PT	TT	WBL LBM/SEC	WEL KG/SEC	DF	INCIDENCE IN DEG	BETA IN DEG	AXIAL VEL	REL VEL
34.	1	1.007	0.3666	1.0036	1.0105	0.9934	0.001	0.001	1.417	-5.16	41.3	1.032	1.012
44.	2	1.003	0.3675	1.0045	1.0115	0.9937	0.001	0.001	1.416	-5.21	41.3	1.033	1.012
54.	3	1.005	0.3680	1.0049	1.0123	0.9939	0.000	0.000	1.415	-5.26	41.4	1.035	1.014
64.	4	1.006	0.3684	1.0060	1.0137	0.9943	-0.001	-0.001	1.414	-5.30	41.4	1.036	1.014
74.	5	1.006	0.3690	1.0076	1.0156	0.9951	-0.004	-0.002	1.413	-5.35	41.4	1.036	1.015
84.	6	1.005	0.3699	1.0075	1.0157	0.9952	-0.005	-0.002	1.412	-5.37	41.5	1.039	1.015
94.	7	1.003	0.3695	1.0075	1.0158	0.9953	-0.006	-0.003	1.412	-5.34	41.5	1.039	1.015
104.	8	1.003	0.3695	1.0074	1.0146	0.9951	-0.008	-0.003	1.412	-5.35	41.5	1.039	1.015
114.	9	1.003	0.3697	0.9930	1.0002	0.9911	-0.008	-0.004	1.410	-5.19	41.3	1.033	1.013
124.	10	1.001	0.3693	0.9845	0.9895	0.9883	-0.009	-0.004	1.408	-4.84	40.9	1.021	1.008
134.	11	1.001	0.3699	0.9852	0.9882	0.9889	-0.008	-0.004	1.404	-4.57	40.7	1.012	1.004
144.	12	1.004	0.3706	0.9861	0.9877	0.9903	-0.005	-0.003	1.403	-4.35	40.5	1.004	1.001
154.	13	0.999	0.3701	0.9864	0.9870	0.9911	-0.006	-0.003	1.403	-4.17	40.3	0.998	0.999
164.	14	0.995	0.3710	0.9860	0.9877	0.9971	-0.004	-0.001	1.402	-4.01	40.1	0.993	0.997
174.	15	0.991	0.3705	0.9811	0.9884	1.0000	-0.003	-0.001	1.401	-3.86	40.0	0.988	0.995
184.	16	0.982	0.3665	0.9828	0.9890	1.0022	-0.001	-0.001	1.402	-3.71	39.8	0.982	0.993
194.	17	0.977	0.3678	0.9840	0.9892	1.0044	0.0	0.0	1.405	-3.55	39.7	0.977	0.991
204.	18	0.973	0.3678	0.9894	0.9906	1.0054	0.000	0.000	1.407	-3.41	39.5	0.973	0.989
214.	19	0.966	0.3691	0.9895	0.9915	1.0060	0.001	0.000	1.400	-3.28	39.4	0.966	0.986
224.	20	0.964	0.3683	0.9882	0.9906	1.0069	0.001	0.001	1.403	-3.14	39.2	0.964	0.986
234.	21	0.965	0.3677	0.9892	0.9908	1.0075	0.002	0.001	1.405	-3.03	39.1	0.960	0.985
244.	22	0.966	0.3650	1.0009	0.9916	1.0082	0.002	0.001	1.407	-2.90	39.0	0.956	0.983
254.	23	0.960	0.3678	1.0019	0.9920	1.0089	0.002	0.001	1.400	-2.81	38.9	0.953	0.982
264.	24	0.950	0.3675	1.0026	0.9922	1.0092	0.002	0.001	1.400	-2.72	38.8	0.950	0.981
274.	25	0.949	0.3671	1.0035	0.9928	1.0097	0.003	0.002	1.400	-2.66	38.8	0.949	0.980
284.	26	0.945	0.3672	1.0040	0.9934	1.0099	0.004	0.002	1.400	-2.70	38.8	0.949	0.981
294.	27	0.941	0.3694	1.0037	0.9944	1.0097	0.005	0.002	1.405	-2.68	38.4	0.966	0.986
304.	28	0.937	0.3680	1.0044	1.0050	1.0107	0.005	0.002	1.406	-2.70	38.2	0.963	0.993
314.	29	0.937	0.3673	1.0076	1.0049	1.0092	0.006	0.003	1.407	-2.80	40.2	0.997	0.999
324.	30	1.005	0.3771	1.0060	1.0067	1.0075	0.006	0.003	1.402	-4.39	40.5	1.005	1.002
334.	31	1.007	0.3771	1.0060	1.0078	1.0084	0.006	0.003	1.401	-4.58	40.7	1.012	1.004
344.	32	1.007	0.3795	1.0067	1.0077	0.9957	0.006	0.003	1.402	-4.70	40.8	1.014	1.006
354.	33	1.009	0.3810	1.0050	1.0074	0.9957	0.005	0.002	1.402	-4.80	40.4	1.019	1.007
364.	34	1.005	0.3784	1.0077	1.0073	0.9935	0.005	0.002	1.402	-4.91	41.0	1.022	1.009
374.	35	1.007	0.3808	1.0071	1.0079	0.9929	0.004	0.002	1.400	-5.01	41.1	1.026	1.010
384.	36	1.009	0.3850	1.0074	1.0087	0.9930	0.004	0.002	1.401	-5.09	41.2	1.029	1.011

APPENDIX B (Cont'd)

STATFL

FLOW SWIRL = 25.44DEG PARTICLE SWIRL = 71.2EDEC
 TTAVG = 14.24PSIA = 125726.PA TTAVG = 779.3DEG R = 394.1DEG K
 FVCLAVG = 133.5FPS = 162.6MPS AXVELAVG = 454.2FPS = 138.5MPS
 PSAVG = 16.12PSIA = 111119.PA
 VELAVG = 543.7FPS = 162.7MPS
 U = 578.FPS = 176.MPS

THETA	SEC	VLL	WV	PS	PT	TT	WBL	WFL	CF	INCIDENCE	ALPHA	AXIAL	REL
DEG	MC	FT	FT	FT	FT	FT	LBM/SEC	KG/SEC		IN DEG	IN DEG	VEL	VEL
27.0	1	1.010	0.4515	1.0047	1.0086	0.9933	0.0	0.0	0.251	-7.23	56.7	1.030	1.030
27.0	2	1.014	0.4517	1.0054	1.0094	0.9928	0.0	0.0	0.251	-7.31	56.3	1.032	1.032
27.0	3	1.018	0.4519	1.0060	1.0104	0.9928	0.0	0.0	0.251	-7.38	56.4	1.033	1.033
27.0	4	1.022	0.4521	1.0067	1.0116	0.9941	0.0	0.0	0.249	-7.45	56.4	1.035	1.035
27.0	5	1.026	0.4523	1.0075	1.0131	0.9947	0.0	0.0	0.247	-7.54	56.5	1.036	1.036
27.0	6	1.030	0.4526	1.0086	1.0153	0.9946	0.0	0.0	0.247	-7.58	56.6	1.037	1.037
27.0	7	1.034	0.4528	1.0098	1.0177	0.9950	0.0	0.0	0.246	-7.60	56.6	1.036	1.036
27.0	8	1.038	0.4531	1.0113	1.0205	0.9949	0.0	0.0	0.246	-7.58	56.6	1.037	1.037
27.0	9	1.042	0.4533	1.0129	1.0236	0.9945	0.0	0.0	0.245	-7.56	56.7	1.037	1.037
27.0	10	1.046	0.4536	1.0147	1.0270	0.9938	0.0	0.0	0.245	-7.54	56.7	1.037	1.037
27.0	11	1.050	0.4539	1.0166	1.0306	0.9930	0.0	0.0	0.244	-7.52	56.7	1.037	1.037
27.0	12	1.054	0.4542	1.0186	1.0343	0.9922	0.0	0.0	0.244	-7.50	56.7	1.037	1.037
27.0	13	1.058	0.4545	1.0207	1.0381	0.9914	0.0	0.0	0.243	-7.48	56.7	1.037	1.037
27.0	14	1.062	0.4548	1.0229	1.0420	0.9906	0.0	0.0	0.243	-7.46	56.7	1.037	1.037
27.0	15	1.066	0.4551	1.0252	1.0460	0.9898	0.0	0.0	0.242	-7.44	56.7	1.037	1.037
27.0	16	1.070	0.4554	1.0276	1.0501	0.9890	0.0	0.0	0.242	-7.42	56.7	1.037	1.037
27.0	17	1.074	0.4557	1.0301	1.0543	0.9882	0.0	0.0	0.241	-7.40	56.7	1.037	1.037
27.0	18	1.078	0.4560	1.0327	1.0586	0.9874	0.0	0.0	0.241	-7.38	56.7	1.037	1.037
27.0	19	1.082	0.4563	1.0353	1.0630	0.9866	0.0	0.0	0.240	-7.36	56.7	1.037	1.037
27.0	20	1.086	0.4566	1.0380	1.0675	0.9858	0.0	0.0	0.240	-7.34	56.7	1.037	1.037
27.0	21	1.090	0.4569	1.0407	1.0721	0.9850	0.0	0.0	0.239	-7.32	56.7	1.037	1.037
27.0	22	1.094	0.4572	1.0435	1.0768	0.9842	0.0	0.0	0.239	-7.30	56.7	1.037	1.037
27.0	23	1.098	0.4575	1.0463	1.0816	0.9834	0.0	0.0	0.238	-7.28	56.7	1.037	1.037
27.0	24	1.102	0.4578	1.0492	1.0864	0.9826	0.0	0.0	0.238	-7.26	56.7	1.037	1.037
27.0	25	1.106	0.4581	1.0521	1.0913	0.9818	0.0	0.0	0.237	-7.24	56.7	1.037	1.037
27.0	26	1.110	0.4584	1.0551	1.0962	0.9810	0.0	0.0	0.237	-7.22	56.7	1.037	1.037
27.0	27	1.114	0.4587	1.0581	1.1012	0.9802	0.0	0.0	0.236	-7.20	56.7	1.037	1.037
27.0	28	1.118	0.4590	1.0612	1.1062	0.9794	0.0	0.0	0.236	-7.18	56.7	1.037	1.037
27.0	29	1.122	0.4593	1.0643	1.1113	0.9786	0.0	0.0	0.235	-7.16	56.7	1.037	1.037
27.0	30	1.126	0.4596	1.0674	1.1164	0.9778	0.0	0.0	0.235	-7.14	56.7	1.037	1.037
27.0	31	1.130	0.4599	1.0706	1.1215	0.9770	0.0	0.0	0.234	-7.12	56.7	1.037	1.037
27.0	32	1.134	0.4602	1.0738	1.1267	0.9762	0.0	0.0	0.234	-7.10	56.7	1.037	1.037
27.0	33	1.138	0.4605	1.0771	1.1319	0.9754	0.0	0.0	0.233	-7.08	56.7	1.037	1.037
27.0	34	1.142	0.4608	1.0804	1.1371	0.9746	0.0	0.0	0.233	-7.06	56.7	1.037	1.037
27.0	35	1.146	0.4611	1.0837	1.1424	0.9738	0.0	0.0	0.232	-7.04	56.7	1.037	1.037
27.0	36	1.150	0.4614	1.0871	1.1476	0.9730	0.0	0.0	0.232	-7.02	56.7	1.037	1.037

STATFL
 PARTICLE

FLOW SWIRL = 25.44DEG PARTICLE SWIRL = 80.36DEG
 TTAVG = 14.15PSIA = 125142.PA TTAVG = 739.2DEG R = 394.1DEG K
 FVCLAVG = 0.742FPS = 205.5MPS AXVELAVG = 460.1FPS = 141.2MPS
 PSAVG = 16.57PSIA = 114270.PA
 VELAVG = 467.2FPS = 142.4MPS
 U = 574.FPS = 175.MPS

THETA	SEC	VLL	WV	PS	PT	TT	WBL	WFL	CF	INCIDENCE	BETA	AXIAL	REL
DEG	MC	FT	FT	FT	FT	FT	LBM/SEC	KG/SEC		IN DEG	IN DEG	VEL	VEL
26.0	1	1.020	0.3745	1.0061	1.0119	0.9933	0.0	0.0	0.340	-4.06	44.0	1.026	1.011
26.0	2	1.023	0.3754	1.0065	1.0130	0.9935	0.0	0.0	0.339	-4.12	44.0	1.030	1.011
26.0	3	1.026	0.3764	1.0074	1.0139	0.9933	0.0	0.0	0.338	-4.16	44.1	1.032	1.012
26.0	4	1.029	0.3774	1.0084	1.0151	0.9941	0.0	0.0	0.337	-4.21	44.1	1.033	1.013
26.0	5	1.032	0.3784	1.0097	1.0167	0.9947	0.0	0.0	0.336	-4.26	44.2	1.035	1.013
26.0	6	1.035	0.3794	1.0110	1.0178	0.9944	0.0	0.0	0.335	-4.30	44.2	1.036	1.014
26.0	7	1.038	0.3804	1.0124	1.0190	0.9940	0.0	0.0	0.335	-4.33	44.2	1.036	1.014
26.0	8	1.041	0.3814	1.0139	1.0204	0.9935	0.0	0.0	0.335	-4.31	44.2	1.036	1.014
26.0	9	1.044	0.3824	1.0154	1.0218	0.9930	0.0	0.0	0.334	-4.31	44.2	1.036	1.014
26.0	10	1.047	0.3834	1.0169	1.0232	0.9925	0.0	0.0	0.334	-4.31	44.2	1.036	1.014
26.0	11	1.050	0.3844	1.0184	1.0246	0.9920	0.0	0.0	0.333	-4.31	44.2	1.036	1.014
26.0	12	1.053	0.3854	1.0199	1.0260	0.9915	0.0	0.0	0.333	-4.31	44.2	1.036	1.014
26.0	13	1.056	0.3864	1.0214	1.0274	0.9910	0.0	0.0	0.332	-4.31	44.2	1.036	1.014
26.0	14	1.059	0.3874	1.0229	1.0288	0.9905	0.0	0.0	0.332	-4.31	44.2	1.036	1.014
26.0	15	1.062	0.3884	1.0244	1.0302	0.9900	0.0	0.0	0.331	-4.31	44.2	1.036	1.014
26.0	16	1.065	0.3894	1.0259	1.0316	0.9895	0.0	0.0	0.331	-4.31	44.2	1.036	1.014
26.0	17	1.068	0.3904	1.0274	1.0330	0.9890	0.0	0.0	0.330	-4.31	44.2	1.036	1.014
26.0	18	1.071	0.3914	1.0289	1.0344	0.9885	0.0	0.0	0.330	-4.31	44.2	1.036	1.014
26.0	19	1.074	0.3924	1.0304	1.0358	0.9880	0.0	0.0	0.329	-4.31	44.2	1.036	1.014
26.0	20	1.077	0.3934	1.0319	1.0372	0.9875	0.0	0.0	0.329	-4.31	44.2	1.036	1.014
26.0	21	1.080	0.3944	1.0334	1.0386	0.9870	0.0	0.0	0.328	-4.31	44.2	1.036	1.014
26.0	22	1.083	0.3954	1.0349	1.0400	0.9865	0.0	0.0	0.328	-4.31	44.2	1.036	1.014
26.0	23	1.086	0.3964	1.0364	1.0414	0.9860	0.0	0.0	0.327	-4.31	44.2	1.036	1.014
26.0	24	1.089	0.3974	1.0379	1.0428	0.9855	0.0	0.0	0.327	-4.31	44.2	1.036	1.014
26.0	25	1.092	0.3984	1.0394	1.0442	0.9850	0.0	0.0	0.326	-4.31	44.2	1.036	1.014
26.0	26	1.095	0.3994	1.0409	1.0456	0.9845	0.0	0.0	0.326	-4.31	44.2	1.036	1.014
26.0	27	1.098	0.4004	1.0424	1.0470	0.9840	0.0	0.0	0.325	-4.31	44.2	1.036	1.014
26.0	28	1.101	0.4014	1.0439	1.0484	0.9835	0.0	0.0	0.325	-4.31	44.2	1.036	1.014
26.0	29	1.104	0.4024	1.0454	1.0498	0.9830	0.0	0.0	0.324	-4.31	44.2	1.036	1.014
26.0	30	1.107	0.4034	1.0469	1.0512	0.9825	0.0	0.0	0.324	-4.31	44.2	1.036	1.014
26.0	31	1.110	0.4044	1.0484	1.0526	0.9820	0.0	0.0	0.323	-4.31	44.2	1.036	1.014
26.0	32	1.113	0.4054	1.0499	1.0540	0.9815	0.0	0.0	0.323	-4.31	44.2	1.036	1.014
26.0	33	1.116	0.4064	1.0514	1.0554	0.9810	0.0	0.0	0.322	-4.31	44.2	1.036	1.014
26.0	34	1.119	0.4074	1.0529	1.0568	0.9805	0.0	0.0	0.322	-4.31	44.2	1.036	1.014
26.0	35	1.122	0.4084	1.0544	1.0582	0.9800	0.0	0.0	0.321	-4.31	44.2	1.036	1.014
26.0	36	1.125	0.4094	1.0559	1.0596	0.9795	0.0	0.0	0.321	-4.31	44.2	1.036	1.014

APPENDIX B (Cont'd)

STATCF

FLOW SWIRL = 25.43 DEG PARTICLE SWIRL = 84.78 DEG PSAVG = 17.76 PSIA = 122435.PA
 PTAVG = 7.17 PSIA = 120.97.PA TTAVG = 725.0 DEG F = 408.8 DEG K VELAVG = 567.3 FPS = 171.4 MPS
 FVLAvg = 570.5 FPS = 174.6 MPS AXVELAVG = 456.8 FPS = 139.6 MPS U = 571.1 FPS = 174.6 MPS

THETA	SIG	VEL	MN	PS	PT	TT	MPL	WBL	DF	INCIDENCE	BETA	AXIAL	REL
DEG	DEG	FT/SEC	FT/SEC	PSIA	DEG F	DEG F	LPM/SEC	KG/SEC	IN DEG	IN DEG	IN DEG	VEL	VEL
35.0	1	1.011	0.4379	1.0079	1.0117	0.9933	0.0	0.0	0.268	-9.65	56.0	1.027	1.027
40.0	2	1.012	0.4381	1.0098	1.0128	0.9925	0.0	0.0	0.267	-9.73	56.0	1.029	1.029
45.0	3	1.013	0.4383	1.0095	1.0136	0.9937	0.0	0.0	0.266	-9.76	56.1	1.030	1.030
50.0	4	1.012	0.4385	1.0105	1.0147	0.9940	0.0	0.0	0.264	-9.85	56.2	1.031	1.031
55.0	5	1.014	0.4388	1.0116	1.0160	0.9945	0.0	0.0	0.263	-9.94	56.2	1.033	1.033
60.0	6	1.014	0.4388	1.0120	1.0164	0.9947	0.0	0.0	0.262	-9.97	56.3	1.034	1.034
65.0	7	1.014	0.4388	1.0122	1.0166	0.9949	0.0	0.0	0.262	-9.99	56.3	1.034	1.034
70.0	8	1.014	0.4388	1.0114	1.0158	0.9947	0.0	0.0	0.262	-9.97	56.3	1.034	1.034
75.0	9	1.015	0.4390	1.0120	1.0161	0.9921	0.0	0.0	0.270	-9.44	55.8	1.023	1.023
80.0	10	1.015	0.4386	0.9972	0.9991	0.9953	0.0	0.0	0.281	-8.84	55.1	1.010	1.010
85.0	11	1.017	0.4393	0.9957	0.9968	0.9901	0.0	0.0	0.287	-8.46	54.6	1.002	1.002
90.0	12	1.019	0.4397	0.9948	0.9950	0.9906	0.0	0.0	0.292	-8.19	54.5	0.996	0.996
95.0	13	1.021	0.4405	0.9931	0.9927	0.9920	0.0	0.0	0.296	-7.92	54.2	0.990	0.990
100.0	14	1.023	0.4410	0.9926	0.9917	0.9948	0.0	0.0	0.299	-7.74	54.0	0.986	0.986
105.0	15	1.025	0.4420	0.9936	0.9910	0.9983	0.0	0.0	0.302	-7.59	53.9	0.983	0.983
110.0	16	1.028	0.4429	0.9927	0.9907	1.0014	0.0	0.0	0.304	-7.44	53.8	0.981	0.981
115.0	17	1.030	0.4436	0.9932	0.9901	1.0036	0.0	0.0	0.306	-7.32	53.6	0.976	0.976
120.0	18	1.031	0.4439	0.9931	0.9897	1.0049	0.0	0.0	0.308	-7.19	53.5	0.975	0.975
125.0	19	1.032	0.4441	0.9927	0.9899	1.0057	0.0	0.0	0.310	-7.06	53.4	0.972	0.972
130.0	20	1.033	0.4441	0.9929	0.9897	1.0068	0.0	0.0	0.312	-6.93	53.2	0.970	0.970
135.0	21	1.034	0.4440	0.9921	0.9897	1.0072	0.0	0.0	0.313	-6.83	53.1	0.966	0.966
140.0	22	1.035	0.4438	0.9920	0.9892	1.0079	0.0	0.0	0.315	-6.72	53.0	0.965	0.965
145.0	23	1.035	0.4436	0.9913	0.9884	1.0084	0.0	0.0	0.316	-6.65	53.0	0.964	0.964
150.0	24	1.036	0.4434	0.9907	0.9886	1.0089	0.0	0.0	0.318	-6.57	52.9	0.962	0.962
155.0	25	1.037	0.4432	0.9904	0.9883	1.0094	0.0	0.0	0.319	-6.50	52.9	0.962	0.962
160.0	26	1.038	0.4430	0.9902	0.9881	1.0098	0.0	0.0	0.320	-6.42	52.9	0.963	0.963
165.0	27	1.039	0.4428	0.9901	0.9882	1.0099	0.0	0.0	0.320	-6.45	52.7	0.960	0.960
170.0	28	1.040	0.4427	0.9905	0.9886	1.0100	0.0	0.0	0.325	-7.96	54.3	0.991	0.991
175.0	29	1.040	0.4426	0.9920	1.0103	1.0085	0.0	0.0	0.327	-7.46	54.6	1.001	1.001
180.0	30	1.041	0.4424	0.9936	1.0107	1.0078	0.0	0.0	0.328	-6.96	55.1	1.006	1.006
185.0	31	1.042	0.4423	0.9951	1.0111	1.0071	0.0	0.0	0.329	-6.46	55.3	1.013	1.013
190.0	32	1.043	0.4422	0.9965	1.0115	1.0064	0.0	0.0	0.329	-6.17	55.5	1.017	1.017
195.0	33	1.044	0.4421	0.9978	1.0119	1.0057	0.0	0.0	0.329	-5.88	55.6	1.019	1.019
200.0	34	1.045	0.4420	0.9991	1.0123	1.0050	0.0	0.0	0.329	-5.58	55.7	1.021	1.021
205.0	35	1.046	0.4419	1.0004	1.0126	1.0043	0.0	0.0	0.329	-5.28	55.8	1.023	1.023
210.0	36	1.047	0.4418	1.0017	1.0129	1.0036	0.0	0.0	0.329	-4.98	55.8	1.025	1.025

STATCF

FLOW SWIRL = 27.30 DEG PARTICLE SWIRL = 84.78 DEG PSAVG = 18.56 PSIA = 127963.PA
 PTAVG = 7.17 PSIA = 14.57.PA TTAVG = 725.0 DEG F = 408.8 DEG K VELAVG = 483.5 FPS = 147.4 MPS
 FVLAvg = 478.9 FPS = 146.5 MPS AXVELAVG = 477.3 FPS = 145.5 MPS U = 565.3 FPS = 172.1 MPS

THETA	SIG	VEL	MN	PS	PT	TT	MPL	WBL	DF	INCIDENCE	BETA	AXIAL	REL
DEG	DEG	FT/SEC	FT/SEC	PSIA	DEG F	DEG F	LPM/SEC	KG/SEC	IN DEG	IN DEG	IN DEG	VEL	VEL
35.0	1	1.017	0.3777	1.0095	1.0123	0.9933	0.009	0.004	0.360	-5.26	45.1	1.017	1.007
40.0	2	1.019	0.3774	1.0102	1.0144	0.9924	0.009	0.004	0.359	-5.32	45.1	1.019	1.008
45.0	3	1.021	0.3777	1.0108	1.0162	0.9937	0.010	0.004	0.359	-5.35	45.2	1.020	1.008
50.0	4	1.023	0.3780	1.0113	1.0182	0.9949	0.010	0.005	0.358	-5.38	45.2	1.020	1.008
55.0	5	1.025	0.3781	1.0118	1.0202	0.9961	0.011	0.005	0.357	-5.42	45.2	1.022	1.009
60.0	6	1.027	0.3785	1.0125	1.0221	0.9974	0.012	0.005	0.357	-5.43	45.2	1.022	1.009
65.0	7	1.029	0.3789	1.0132	1.0241	0.9986	0.012	0.005	0.357	-5.44	45.2	1.022	1.009
70.0	8	1.031	0.3795	1.0140	1.0261	0.9997	0.011	0.005	0.357	-5.43	45.2	1.022	1.009
75.0	9	1.033	0.3797	1.0148	1.0281	0.9921	0.006	0.003	0.361	-5.27	45.1	1.017	1.007
80.0	10	1.035	0.3798	0.9977	1.0300	0.9933	-0.006	-0.000	0.367	-4.65	44.8	1.010	1.004
85.0	11	1.037	0.3801	0.9967	0.9976	0.9961	-0.003	-0.001	0.370	-4.69	44.7	1.006	1.002
90.0	12	1.039	0.3806	0.9958	0.9966	0.9965	-0.005	-0.002	0.372	-4.77	44.6	1.002	1.001
95.0	13	1.041	0.3809	0.9951	0.9952	0.9950	-0.007	-0.003	0.375	-4.85	44.5	0.998	0.995
100.0	14	1.043	0.3811	0.9946	0.9941	0.9948	-0.008	-0.003	0.377	-4.95	44.4	0.995	0.998
105.0	15	1.045	0.3814	0.9941	0.9932	0.9951	-0.008	-0.004	0.379	-4.97	44.3	0.993	0.997
110.0	16	1.047	0.3818	0.9938	0.9924	0.9954	-0.010	-0.004	0.380	-4.99	44.2	0.991	0.996
115.0	17	1.049	0.3822	0.9935	0.9915	0.9987	-0.009	-0.004	0.381	-4.91	44.1	0.988	0.995
120.0	18	1.051	0.3826	0.9932	0.9906	1.0019	-0.009	-0.004	0.382	-4.84	44.0	0.986	0.994
125.0	19	1.053	0.3830	0.9929	0.9897	1.0051	-0.010	-0.004	0.383	-4.77	44.0	0.984	0.993
130.0	20	1.055	0.3834	0.9926	0.9888	1.0084	-0.011	-0.005	0.384	-4.72	43.9	0.982	0.993
135.0	21	1.057	0.3838	0.9923	0.9879	1.0117	-0.011	-0.005	0.385	-4.65	43.9	0.980	0.992
140.0	22	1.059	0.3842	0.9920	0.9870	1.0150	-0.012	-0.005	0.386	-4.60	43.8	0.979	0.991
145.0	23	1.061	0.3846	0.9917	0.9861	1.0183	-0.012	-0.005	0.387	-4.55	43.7	0.977	0.991
150.0	24	1.063	0.3850	0.9914	0.9852	1.0216	-0.012	-0.005	0.388	-4.50	43.7	0.975	0.990
155.0	25	1.065	0.3854	0.9911	0.9843	1.0249	-0.012	-0.005	0.388	-4.45	43.6	0.974	0.990
160.0	26	1.067	0.3858	0.9908	0.9834	1.0282	-0.011	-0.005	0.388	-4.40	43.6	0.974	0.990
165.0	27	1.069	0.3862	0.9905	0.9825	1.0315	-0.011	-0.005	0.388	-4.36	43.8	0.978	0.991
170.0	28	1.071	0.3866	0.9902	0.9816	1.0348	-0.011	-0.005	0.388	-4.30	44.1	0.988	0.995
175.0	29	1.073	0.3870	0.9900	0.9807	1.0381	-0.011	-0.005	0.388	-4.25	44.3	0.995	0.998
180.0	30	1.075	0.3874	0.9897	0.9798	1.0414	-0.011	-0.005	0.388	-4.20	44.5	1.000	1.000
185.0	31	1.077	0.3878	0.9894	0.9789	1.0447	-0.011	-0.005	0.388	-4.15	44.6	1.004	1.002
190.0	32	1.079	0.3882	0.9891	0.9780	1.0480	-0.011	-0.005	0.388	-4.10	44.8	1.007	1.003
195.0	33	1.081	0.3886	0.9888	0.9771	1.0513	-0.011	-0.005	0.388	-4.05	44.8	1.010	1.004
200.0	34	1.083	0.3890	0.9885	0.9762	1.0546	-0.011	-0.005	0.388	-4.00	44.9	1.012	1.005
205.0	35	1.085	0.3894	0.9882	0.9753	1.0579	-0.011	-0.005	0.388	-3.95	45.0	1.014	1.006
210.0	36	1.087	0.3898	0.9879	0.9744	1.0612	-0.011	-0.005	0.388	-3.90	45.0	1.016	1.006

APPENDIX B (Cont'd)

STAGE 2

FLOW SWIRL= 27.00DEG PARTICLE SWIRL= 92.27DEG
 TAVG= 27.00FPS = 157826.PA TTAVG= 758.70DEG R = 421.50DEG K
 PVELAVG= 421.1FPS = 158.8MPS AXVELAVG= 484.5FPS = 147.7MPS
 PSAVG= 19.81PSIA = 136593.PA
 VELAVG= 407.3FPS = 185.1MPS
 U= 556.FPS = 170.MPS

THETA	SEG	VEL	MN	PS	PT	TT	WBL	WBL	DF	INCIDENCE	BETA	AXIAL	REL
DEG	NO	FT/SEC	PS	PS	PS	PS	LBM/SEC	KG/SEC	DEG	IN DEG	IN DEG	VEL	VEL
40.	1	1.008	0.4657	1.0072	1.0107	0.9920	0.0	0.0	0.238	-14.26	53.7	1.018	1.018
45.	2	1.009	0.4659	1.0079	1.0116	0.9930	0.0	0.0	0.237	-14.34	53.7	1.020	1.020
50.	3	1.009	0.4660	1.0085	1.0123	0.9931	0.0	0.0	0.236	-14.37	53.6	1.020	1.020
55.	4	1.010	0.4662	1.0094	1.0132	0.9934	0.0	0.0	0.235	-14.41	53.8	1.021	1.021
60.	5	1.010	0.4663	1.0104	1.0143	0.9937	0.0	0.0	0.234	-14.46	53.9	1.022	1.022
65.	6	1.010	0.4664	1.0107	1.0147	0.9939	0.0	0.0	0.234	-14.48	53.9	1.023	1.023
70.	7	1.010	0.4664	1.0109	1.0149	0.9941	0.0	0.0	0.234	-14.49	53.9	1.023	1.023
75.	8	1.010	0.4663	1.0103	1.0142	0.9940	0.0	0.0	0.234	-14.47	53.9	1.023	1.023
80.	9	1.007	0.4651	1.0035	1.0067	0.9919	0.0	0.0	0.240	-14.20	53.6	1.016	1.016
85.	10	1.003	0.4637	0.9991	1.0014	0.9905	0.0	0.0	0.246	-13.88	53.3	1.006	1.006
90.	11	1.001	0.4627	0.9973	0.9989	0.9902	0.0	0.0	0.250	-13.68	53.1	1.004	1.004
95.	12	0.999	0.4618	0.9959	0.9970	0.9906	0.0	0.0	0.254	-13.51	52.9	1.000	1.000
100.	13	0.997	0.4605	0.9942	0.9946	0.9916	0.0	0.0	0.257	-13.34	52.7	0.996	0.996
105.	14	0.995	0.4592	0.9936	0.9931	0.9938	0.0	0.0	0.260	-13.21	52.6	0.992	0.992
110.	15	0.994	0.4579	0.9933	0.9920	0.9969	0.0	0.0	0.261	-13.10	52.5	0.990	0.990
115.	16	0.994	0.4568	0.9933	0.9913	1.0002	0.0	0.0	0.263	-13.02	52.4	0.988	0.988
120.	17	0.993	0.4559	0.9932	0.9907	1.0028	0.0	0.0	0.264	-12.94	52.4	0.986	0.986
125.	18	0.992	0.4553	0.9930	0.9901	1.0046	0.0	0.0	0.266	-12.87	52.3	0.986	0.986
130.	19	0.992	0.4547	0.9926	0.9893	1.0057	0.0	0.0	0.267	-12.79	52.2	0.985	0.985
135.	20	0.991	0.4542	0.9924	0.9889	1.0066	0.0	0.0	0.268	-12.73	52.1	0.981	0.981
140.	21	0.990	0.4537	0.9918	0.9880	1.0073	0.0	0.0	0.270	-12.66	52.0	0.979	0.979
145.	22	0.990	0.4533	0.9915	0.9874	1.0080	0.0	0.0	0.271	-12.60	52.0	0.979	0.979
150.	23	0.989	0.4528	0.9911	0.9867	1.0086	0.0	0.0	0.272	-12.53	52.0	0.978	0.978
155.	24	0.989	0.4524	0.9906	0.9860	1.0092	0.0	0.0	0.274	-12.46	51.9	0.976	0.976
160.	25	0.988	0.4521	0.9906	0.9858	1.0097	0.0	0.0	0.274	-12.42	51.8	0.975	0.975
165.	26	0.989	0.4521	0.9909	0.9861	1.0101	0.0	0.0	0.274	-12.43	51.8	0.974	0.974
170.	27	0.992	0.4526	0.9941	0.9902	1.0104	0.0	0.0	0.270	-12.64	52.0	0.979	0.979
175.	28	0.997	0.4562	1.0006	0.9982	1.0108	0.0	0.0	0.260	-13.13	52.5	0.991	0.991
180.	29	1.000	0.4578	1.0020	1.0006	1.0094	0.0	0.0	0.255	-13.41	52.8	0.999	0.999
185.	30	1.002	0.4591	1.0035	1.0028	1.0081	0.0	0.0	0.251	-13.62	53.0	1.002	1.002
190.	31	1.004	0.4604	1.0052	1.0054	1.0064	0.0	0.0	0.247	-13.81	53.2	1.010	1.010
195.	32	1.006	0.4618	1.0062	1.0072	1.0039	0.0	0.0	0.244	-13.95	53.3	1.012	1.012
200.	33	1.007	0.4631	1.0063	1.0083	1.0004	0.0	0.0	0.243	-14.05	53.4	1.012	1.012
205.	34	1.007	0.4642	1.0062	1.0088	0.9968	0.0	0.0	0.241	-14.11	53.5	1.014	1.014
210.	35	1.007	0.4649	1.0061	1.0097	0.9943	0.0	0.0	0.240	-14.16	53.6	1.015	1.015
215.	36	1.008	0.4653	1.0062	1.0096	0.9931	0.0	0.0	0.239	-14.21	53.6	1.016	1.016

STAGE 2
 ROTOR

FLOW SWIRL= 30.45DEG PARTICLE SWIRL= 95.04DEG
 TAVG= 22.58PSIA = 155700.PA TTAVG= 758.70DEG R = 421.50DEG K
 PVELAVG= 425.6FPS = 196.7MPS AXVELAVG= 495.0FPS = 150.9MPS
 PSAVG= 20.92PSIA = 139895.PA
 VELAVG= 524.0FPS = 159.7MPS
 U= 554.FPS = 169.MPS

THETA	SEG	VEL	MN	PS	PT	TT	WBL	WBL	DF	INCIDENCE	BETA	AXIAL	REL
DEG	NO	FT/SEC	PS	PS	PS	PS	LBM/SEC	KG/SEC	DEG	IN DEG	IN DEG	VEL	VEL
40.	1	1.020	0.4042	1.0054	1.0104	0.9929	0.0	0.0	0.243	-9.20	53.1	1.020	1.009
50.	2	1.021	0.4048	1.0055	1.0113	0.9937	0.0	0.0	0.242	-9.26	53.2	1.021	1.010
60.	3	1.022	0.4052	1.0064	1.0120	0.9931	0.0	0.0	0.241	-9.29	53.2	1.022	1.010
70.	4	1.023	0.4055	1.0072	1.0130	0.9934	0.0	0.0	0.240	-9.33	53.2	1.023	1.011
80.	5	1.024	0.4060	1.0080	1.0140	0.9937	0.0	0.0	0.239	-9.38	53.3	1.024	1.011
90.	6	1.025	0.4062	1.0082	1.0144	0.9939	0.0	0.0	0.239	-9.41	53.3	1.025	1.012
100.	7	1.025	0.4062	1.0084	1.0146	0.9941	0.0	0.0	0.238	-9.42	53.3	1.025	1.012
110.	8	1.025	0.4061	1.0079	1.0140	0.9940	0.0	0.0	0.239	-9.40	53.3	1.025	1.011
120.	9	1.017	0.4035	1.0020	1.0067	0.9919	0.0	0.0	0.246	-9.11	53.0	1.017	1.006
130.	10	1.009	0.4002	0.9987	1.0015	0.9905	0.0	0.0	0.252	-8.76	52.7	1.009	1.006
140.	11	1.003	0.3981	0.9975	0.9992	0.9902	0.0	0.0	0.256	-8.55	52.4	1.003	1.001
150.	12	0.999	0.3963	0.9965	0.9972	0.9906	0.0	0.0	0.259	-8.38	52.3	0.999	1.000
160.	13	0.995	0.3943	0.9952	0.9949	0.9916	0.0	0.0	0.263	-8.20	52.1	0.995	0.996
170.	14	0.991	0.3925	0.9947	0.9935	0.9938	0.0	0.0	0.265	-8.06	52.0	0.991	0.996
180.	15	0.989	0.3908	0.9946	0.9924	0.9969	0.0	0.0	0.267	-7.96	51.9	0.989	0.995
190.	16	0.987	0.3894	0.9947	0.9917	1.0002	0.0	0.0	0.268	-7.88	51.8	0.987	0.994
200.	17	0.985	0.3880	0.9946	0.9910	1.0028	0.0	0.0	0.269	-7.80	51.7	0.985	0.993
210.	18	0.983	0.3870	0.9945	0.9904	1.0046	0.0	0.0	0.270	-7.73	51.6	0.983	0.992
220.	19	0.981	0.3860	0.9943	0.9896	1.0057	0.0	0.0	0.271	-7.65	51.6	0.981	0.991
230.	20	0.980	0.3853	0.9942	0.9891	1.0066	0.0	0.0	0.271	-7.59	51.5	0.980	0.991
240.	21	0.978	0.3843	0.9937	0.9882	1.0073	0.0	0.0	0.273	-7.52	51.4	0.978	0.990
250.	22	0.976	0.3836	0.9935	0.9876	1.0080	0.0	0.0	0.274	-7.46	51.4	0.976	0.989
260.	23	0.975	0.3828	0.9932	0.9868	1.0086	0.0	0.0	0.275	-7.39	51.3	0.975	0.989
270.	24	0.973	0.3820	0.9924	0.9861	1.0092	0.0	0.0	0.276	-7.32	51.2	0.973	0.988
280.	25	0.972	0.3816	0.9929	0.9859	1.0097	0.0	0.0	0.276	-7.28	51.2	0.972	0.987
290.	26	0.972	0.3816	0.9931	0.9862	1.0101	0.0	0.0	0.276	-7.29	51.2	0.972	0.987
300.	27	0.978	0.3837	0.9960	0.9900	1.0104	0.0	0.0	0.271	-7.51	51.4	0.978	0.990
310.	28	0.990	0.3866	1.0015	0.9981	1.0108	0.0	0.0	0.261	-6.01	51.9	0.990	0.995
320.	29	0.997	0.3917	1.0023	1.0006	1.0094	0.0	0.0	0.256	-6.29	52.2	0.997	0.999
330.	30	1.002	0.3941	1.0033	1.0028	1.0081	0.0	0.0	0.253	-6.51	52.4	1.002	1.001
340.	31	1.007	0.3964	1.0045	1.0053	1.0064	0.0	0.0	0.250	-6.70	52.6	1.007	1.003
350.	32	1.011	0.3984	1.0051	1.0070	1.0029	0.0	0.0	0.247	-6.85	52.8	1.011	1.005
360.	33	1.014	0.4002	1.0051	1.0079	1.0004	0.0	0.0	0.245	-6.95	52.5	1.014	1.006
370.	34	1.015	0.4015	1.0048	1.0084	0.9968	0.0	0.0	0.245	-6.91	52.9	1.015	1.007
380.	35	1.016	0.4026	1.0047	1.0089	0.9943	0.0	0.0	0.244	-6.97	53.0	1.016	1.007
390.	36	1.018	0.4034	1.0047	1.0094	0.9931	0.0	0.0	0.244	-6.92	53.0	1.018	1.008

STATOR

FLOW SWIRL= 45.61DEG PARTICLE SWIRL=122.67DEG PSAVG= 25.91PSIA = 178672.PA
 PTAVG= 32.18PSIA = 221288.PA TTAVG= 848.5DFG R = 471.4DEG K VELAVG= 782.6FPS =238.5MPS
 RVELAVG= 669.2FPS = 204.6MPS AXVELAVG= 560.0FPS =170.7MPS U= 913.FPS = 278.MPS

NO	THETA	SFG	VEL	MN	PS	PT	TT	WBL	WBL	DF	INCIDENCE	ALPHA	AXIAL	REL
								LBM/SEC	KG/SEC		IN DEG	IN DEG	VEL	VEL
56.	1	1.001	0.5695	1.0052	1.0070	0.9940	0.0	0.0	0.393	4.75	45.9	1.003	1.003	
66.	2	1.001	0.5696	1.0051	1.0070	0.9936	0.0	0.0	0.392	4.70	45.9	1.004	1.004	
76.	3	1.001	0.5695	1.0052	1.0071	0.9937	0.0	0.0	0.391	4.66	45.9	1.005	1.005	
86.	4	1.001	0.5695	1.0056	1.0074	0.9938	0.0	0.0	0.391	4.65	46.0	1.005	1.005	
96.	5	1.001	0.5694	1.0059	1.0077	0.9941	0.0	0.0	0.390	4.64	46.0	1.006	1.006	
106.	6	1.001	0.5693	1.0062	1.0079	0.9943	0.0	0.0	0.390	4.64	46.0	1.006	1.006	
116.	7	1.001	0.5692	1.0063	1.0079	0.9945	0.0	0.0	0.390	4.64	46.0	1.006	1.006	
126.	8	1.001	0.5692	1.0061	1.0078	0.9945	0.0	0.0	0.390	4.64	46.0	1.006	1.006	
136.	9	1.001	0.5697	1.0056	1.0056	0.9934	0.0	0.0	0.391	4.65	45.9	1.005	1.005	
146.	10	1.001	0.5700	1.0010	1.0033	0.9921	0.0	0.0	0.391	4.67	45.9	1.005	1.005	
156.	11	1.001	0.5701	0.9995	1.0018	0.9914	0.0	0.0	0.391	4.69	45.9	1.005	1.005	
166.	12	1.001	0.5700	0.9981	1.0004	0.9911	0.0	0.0	0.392	4.70	45.9	1.004	1.004	
176.	13	1.000	0.5698	0.9967	0.9988	0.9914	0.0	0.0	0.392	4.71	45.9	1.004	1.004	
186.	14	1.000	0.5692	0.9957	0.9974	0.9924	0.0	0.0	0.393	4.75	45.9	1.003	1.003	
196.	15	0.999	0.5683	0.9950	0.9960	0.9944	0.0	0.0	0.394	4.79	45.8	1.002	1.002	
206.	16	0.999	0.5672	0.9946	0.9948	0.9971	0.0	0.0	0.395	4.85	45.8	1.001	1.001	
216.	17	0.999	0.5662	0.9945	0.9939	0.9999	0.0	0.0	0.394	4.91	45.7	1.000	1.000	
226.	18	0.999	0.5655	0.9947	0.9936	1.0023	0.0	0.0	0.397	4.98	45.6	0.999	0.999	
236.	19	0.999	0.5650	0.9949	0.9934	1.0040	0.0	0.0	0.399	5.05	45.6	0.997	0.997	
246.	20	0.999	0.5647	0.9950	0.9932	1.0051	0.0	0.0	0.400	5.11	45.5	0.996	0.996	
256.	21	0.999	0.5644	0.9946	0.9927	1.0059	0.0	0.0	0.401	5.15	45.5	0.995	0.995	
266.	22	0.999	0.5642	0.9945	0.9923	1.0066	0.0	0.0	0.402	5.18	45.4	0.994	0.994	
276.	23	0.998	0.5640	0.9941	0.9918	1.0072	0.0	0.0	0.402	5.21	45.4	0.994	0.994	
286.	24	0.998	0.5638	0.9937	0.9913	1.0077	0.0	0.0	0.403	5.23	45.4	0.993	0.993	
296.	25	0.998	0.5636	0.9937	0.9911	1.0083	0.0	0.0	0.403	5.25	45.4	0.993	0.993	
306.	26	0.998	0.5635	0.9939	0.9913	1.0089	0.0	0.0	0.403	5.26	45.3	0.993	0.993	
316.	27	0.999	0.5634	0.9935	0.9928	1.0095	0.0	0.0	0.403	5.26	45.4	0.993	0.993	
326.	28	0.999	0.5635	0.9932	0.9965	1.0104	0.0	0.0	0.402	5.21	45.4	0.994	0.994	
336.	29	1.000	0.5640	1.0007	0.9984	1.0098	0.0	0.0	0.401	5.15	45.5	0.995	0.995	
346.	30	1.000	0.5645	1.0020	1.0000	1.0087	0.0	0.0	0.400	5.10	45.5	0.996	0.996	
356.	31	1.000	0.5650	1.0031	1.0016	1.0075	0.0	0.0	0.399	5.05	45.6	0.997	0.997	
6.	32	1.001	0.5657	1.0043	1.0033	1.0059	0.0	0.0	0.398	5.00	45.6	0.998	0.998	
16.	33	1.001	0.5666	1.0053	1.0050	1.0035	0.0	0.0	0.397	4.97	45.6	0.999	0.999	
26.	34	1.001	0.5677	1.0057	1.0062	1.0005	0.0	0.0	0.396	4.93	45.7	1.000	1.000	
36.	35	1.001	0.5686	1.0056	1.0068	0.9975	0.0	0.0	0.395	4.87	45.7	1.001	1.001	
46.	36	1.001	0.5692	1.0054	1.0071	0.9952	0.0	0.0	0.394	4.81	45.8	1.002	1.002	

STAGE 11 ROTOR

FLOW SWIRL= 48.73DEG PARTICLE SWIRL=125.79DEG PSAVG= 27.52PSIA = 189749.PA
 PTAVG= 31.40PSIA = 216521.PA TTAVG= 848.5DEG R = 471.4DEG K VELAVG= 614.5FPS =187.3MPS
 RVELAVG= 672.0FPS = 205.8MPS AXVELAVG= 561.1FPS =171.0MPS U= 918.FPS = 280.MPS

NO	THETA	SFG	VEL	MN	PS	PT	TT	WBL	WBL	DF	INCIDENCE	BETA	AXIAL	REL
								LBM/SEC	KG/SEC		IN DEG	IN DEG	VEL	VEL
59.	1	1.003	0.4427	1.0055	1.0072	0.9940	0.0	0.0	0.329	-0.08	40.2	1.003	1.001	
69.	2	1.004	0.4432	1.0055	1.0075	0.9936	0.0	0.0	0.328	-0.12	40.2	1.004	1.001	
79.	3	1.005	0.4435	1.0056	1.0077	0.9937	0.0	0.0	0.328	-0.16	40.2	1.005	1.001	
89.	4	1.005	0.4436	1.0059	1.0081	0.9938	0.0	0.0	0.327	-0.15	40.3	1.005	1.001	
99.	5	1.005	0.4437	1.0063	1.0085	0.9941	0.0	0.0	0.327	-0.16	40.3	1.005	1.001	
109.	6	1.005	0.4436	1.0065	1.0087	0.9943	0.0	0.0	0.327	-0.16	40.3	1.005	1.001	
119.	7	1.005	0.4436	1.0065	1.0087	0.9945	0.0	0.0	0.327	-0.16	40.3	1.005	1.001	
129.	8	1.005	0.4436	1.0064	1.0086	0.9945	0.0	0.0	0.327	-0.16	40.3	1.005	1.001	
139.	9	1.005	0.4437	1.0039	1.0062	0.9934	0.0	0.0	0.327	-0.15	40.2	1.005	1.001	
149.	10	1.005	0.4438	1.0015	1.0038	0.9921	0.0	0.0	0.328	-0.13	40.2	1.005	1.001	
159.	11	1.004	0.4438	1.0000	1.0023	0.9914	0.0	0.0	0.329	-0.12	40.2	1.005	1.001	
169.	12	1.004	0.4437	0.9986	1.0009	0.9911	0.0	0.0	0.329	-0.11	40.2	1.004	1.001	
179.	13	1.004	0.4435	0.9973	0.9994	0.9914	0.0	0.0	0.330	-0.09	40.2	1.004	1.001	
189.	14	1.003	0.4430	0.9962	0.9980	0.9924	0.0	0.0	0.331	-0.07	40.2	1.003	1.001	
199.	15	1.002	0.4421	0.9954	0.9966	0.9944	0.0	0.0	0.333	-0.04	40.1	1.002	1.000	
209.	16	1.001	0.4411	0.9948	0.9954	0.9971	0.0	0.0	0.334	0.00	40.1	1.001	1.000	
219.	17	1.000	0.4399	0.9945	0.9944	0.9999	0.0	0.0	0.336	0.05	40.0	1.000	1.000	
229.	18	0.999	0.4388	0.9945	0.9938	1.0023	0.0	0.0	0.337	0.10	40.0	0.999	1.000	
239.	19	0.997	0.4378	0.9946	0.9933	1.0040	0.0	0.0	0.338	0.15	40.0	0.997	0.999	
249.	20	0.996	0.4371	0.9947	0.9936	1.0051	0.0	0.0	0.340	0.19	39.9	0.996	0.999	
259.	21	0.995	0.4365	0.9943	0.9923	1.0059	0.0	0.0	0.341	0.23	39.9	0.995	0.999	
269.	22	0.995	0.4360	0.9941	0.9918	1.0066	0.0	0.0	0.341	0.25	39.8	0.995	0.999	
279.	23	0.994	0.4357	0.9937	0.9912	1.0072	0.0	0.0	0.342	0.27	39.8	0.994	0.999	
289.	24	0.994	0.4354	0.9933	0.9906	1.0077	0.0	0.0	0.342	0.29	39.8	0.994	0.999	
299.	25	0.993	0.4351	0.9933	0.9904	1.0082	0.0	0.0	0.343	0.30	39.8	0.993	0.999	
309.	26	0.993	0.4349	0.9935	0.9905	1.0089	0.0	0.0	0.343	0.31	39.8	0.993	0.999	
319.	27	0.994	0.4349	0.9950	0.9920	1.0095	0.0	0.0	0.342	0.29	39.8	0.994	0.999	
329.	28	0.994	0.4351	0.9986	0.9957	1.0104	0.0	0.0	0.340	0.26	39.8	0.994	0.999	
339.	29	0.996	0.4358	1.0001	0.9976	1.0098	0.0	0.0	0.338	0.21	39.9	0.996	0.999	
349.	30	0.997	0.4364	1.0015	0.9993	1.0087	0.0	0.0	0.337	0.18	39.9	0.997	0.999	
359.	31	0.998	0.4372	1.0026	1.0010	1.0075	0.0	0.0	0.335	0.14	40.0	0.998	1.000	
9.	32	0.998	0.4379	1.0039	1.0027	1.0059	0.0	0.0	0.334	0.11	40.0	0.998	1.000	
19.	33	0.999	0.4387	1.0051	1.0044	1.0035	0.0	0.0	0.333	0.08	40.0	0.999	1.000	
29.	34	1.000	0.4397	1.0056	1.0055	1.0005	0.0	0.0	0.333	0.05	40.0	1.000	1.000	
39.	35	1.001	0.4408	1.0058	1.0063	0.9975	0.0	0.0	0.332	0.02	40.1	1.001	1.000	
49.	36	1.002	0.4418	1.0057	1.0068	0.9952	0.0	0.0	0.331	-0.03	40.1	1.002	1.000	

APPENDIX B (Cont'd)

STATOR

FLOW SWIRL= 49.81DEG PARTICLE SWIRL=131.41DEG PSAVG= 36.74PSIA = 211972.PA
 PTAVG= 27.26PSIA = 256874.PA TTAVG= 807.1DEG R = 498.4DEG K VELAVG= 759.2FPS = 231.4MPS
 RVELAVG= 693.9FPS = 211.5MPS AXVELAVG= 559.6FPS = 170.6MPS U= 924.FPS = 281.MPS

THETA	SEG NO	VEL	MN	PS	PT	TT	WBL LBM/SEC	MBL KG/SEC	DF	INCIDENCE IN DEG	BETA IN DEG	AXIAL IN DEG	REL VEL
60.	1	1.002	0.5359	1.0046	1.0063	0.9946	0.0	0.0	0.297	0.29	47.7	1.005	1.005
70.	2	1.001	0.5360	1.0042	1.0060	0.9938	0.0	0.0	0.296	0.23	47.8	1.006	1.006
80.	3	1.001	0.5360	1.0041	1.0156	0.9936	0.0	0.0	0.295	0.20	47.8	1.006	1.006
90.	4	1.001	0.5359	1.0043	1.0060	0.9938	0.0	0.0	0.294	0.18	47.8	1.007	1.007
100.	5	1.001	0.5359	1.0046	1.0063	0.9940	0.0	0.0	0.294	0.17	47.8	1.007	1.007
110.	6	1.001	0.5358	1.0047	1.0064	0.9942	0.0	0.0	0.294	0.16	47.8	1.007	1.007
120.	7	1.001	0.5358	1.0048	1.0064	0.9943	0.0	0.0	0.294	0.16	47.8	1.007	1.007
130.	8	1.001	0.5357	1.0048	1.0063	0.9944	0.0	0.0	0.294	0.17	47.8	1.007	1.007
140.	9	1.001	0.5360	1.0027	1.0145	0.9936	0.0	0.0	0.295	0.19	47.8	1.006	1.006
150.	10	1.001	0.5362	1.0008	1.0027	0.9925	0.0	0.0	0.296	0.23	47.8	1.006	1.006
160.	11	1.001	0.5363	0.9997	1.0017	0.9918	0.0	0.0	0.296	0.27	47.7	1.005	1.005
170.	12	1.001	0.5363	0.9984	1.0004	0.9913	0.0	0.0	0.297	0.29	47.7	1.004	1.004
180.	13	1.000	0.5361	0.9973	0.9991	0.9914	0.0	0.0	0.298	0.34	47.7	1.004	1.004
190.	14	1.000	0.5356	0.9964	0.9978	0.9921	0.0	0.0	0.299	0.39	47.6	1.003	1.003
200.	15	0.999	0.5348	0.9957	0.9967	0.9937	0.0	0.0	0.301	0.47	47.5	1.001	1.001
210.	16	0.999	0.5339	0.9952	0.9955	0.9960	0.0	0.0	0.302	0.54	47.5	1.000	1.000
220.	17	0.998	0.5330	0.9951	0.9947	0.9987	0.0	0.0	0.304	0.62	47.4	0.998	0.998
230.	18	0.998	0.5322	0.9953	0.9943	1.0013	0.0	0.0	0.305	0.68	47.3	0.997	0.997
240.	19	0.998	0.5317	0.9957	0.9944	1.0032	0.0	0.0	0.306	0.75	47.3	0.996	0.996
250.	20	0.998	0.5313	0.9961	0.9945	1.0047	0.0	0.0	0.307	0.81	47.2	0.994	0.994
260.	21	0.998	0.5311	0.9959	0.9941	1.0056	0.0	0.0	0.308	0.86	47.1	0.993	0.993
270.	22	0.998	0.5309	0.9958	0.9939	1.0063	0.0	0.0	0.309	0.90	47.1	0.993	0.993
280.	23	0.998	0.5307	0.9955	0.9934	1.0069	0.0	0.0	0.310	0.93	47.1	0.992	0.992
290.	24	0.998	0.5305	0.9952	0.9930	1.0075	0.0	0.0	0.310	0.95	47.0	0.992	0.992
300.	25	0.998	0.5303	0.9952	0.9929	1.0081	0.0	0.0	0.311	0.97	47.0	0.991	0.991
310.	26	0.998	0.5302	0.9953	0.9929	1.0086	0.0	0.0	0.311	0.98	47.0	0.991	0.991
320.	27	0.999	0.5302	0.9963	0.9939	1.0093	0.0	0.0	0.310	0.93	47.1	0.992	0.992
330.	28	0.999	0.5303	0.9992	0.9948	1.0102	0.0	0.0	0.308	0.85	47.1	0.994	0.994
340.	29	1.000	0.5307	1.0000	0.9960	1.0099	0.0	0.0	0.306	0.74	47.3	0.996	0.996
350.	30	1.000	0.5312	1.0012	0.9995	1.0091	0.0	0.0	0.304	0.67	47.3	0.997	0.997
360.	31	1.001	0.5317	1.0021	1.0007	1.0078	0.0	0.0	0.303	0.60	47.4	0.998	0.998
10.	32	1.001	0.5322	1.0033	1.0023	1.0064	0.0	0.0	0.301	0.54	47.5	1.000	1.000
20.	33	1.001	0.5329	1.0047	1.0042	1.0045	0.0	0.0	0.301	0.50	47.5	1.000	1.000
30.	34	1.001	0.5338	1.0054	1.0054	1.0018	0.0	0.0	0.300	0.46	47.5	1.001	1.001
40.	35	1.002	0.5346	1.0056	1.0065	0.9988	0.0	0.0	0.299	0.41	47.6	1.002	1.002
50.	36	1.002	0.5354	1.0053	1.0067	0.9963	0.0	0.0	0.298	0.35	47.6	1.003	1.003

STAGE 17 ROTOR

FLOW SWIRL= 52.91DEG PARTICLE SWIRL=134.51DEG PSAVG= 32.35PSIA = 223020.PA
 PTAVG= 31.78PSIA = 253557.PA TTAVG= 807.1DEG R = 498.4DEG K VELAVG= 623.2FPS = 190.0MPS
 RVELAVG= 862.4FPS = 262.9MPS AXVELAVG= 560.7FPS = 170.9MPS U= 927.FPS = 283.MPS

THETA	SEG NO	VEL	MN	PS	PT	TT	WBL LBM/SEC	MBL KG/SEC	DF	INCIDENCE IN DEG	BETA IN DEG	AXIAL IN DEG	REL VEL
63.	1	1.005	0.4373	1.0046	1.0065	0.9946	0.0	0.0	0.252	-3.04	40.7	1.005	1.001
73.	2	1.006	0.4380	1.0041	1.0064	0.9938	0.0	0.0	0.251	-3.08	40.8	1.006	1.001
83.	3	1.006	0.4383	1.0039	1.0064	0.9936	0.0	0.0	0.251	-3.11	40.8	1.006	1.001
93.	4	1.007	0.4385	1.0041	1.0067	0.9938	0.0	0.0	0.250	-3.13	40.8	1.007	1.001
103.	5	1.007	0.4386	1.0043	1.0069	0.9940	0.0	0.0	0.250	-3.14	40.8	1.007	1.001
113.	6	1.007	0.4386	1.0044	1.0071	0.9942	0.0	0.0	0.250	-3.14	40.8	1.007	1.001
123.	7	1.007	0.4385	1.0045	1.0071	0.9943	0.0	0.0	0.250	-3.14	40.8	1.007	1.001
133.	8	1.007	0.4385	1.0044	1.0070	0.9944	0.0	0.0	0.250	-3.14	40.8	1.007	1.001
143.	9	1.007	0.4384	1.0025	1.0050	0.9936	0.0	0.0	0.251	-3.11	40.8	1.007	1.001
153.	10	1.006	0.4383	1.0007	1.0032	0.9925	0.0	0.0	0.252	-3.08	40.8	1.006	1.001
163.	11	1.005	0.4380	0.9998	1.0021	0.9918	0.0	0.0	0.253	-3.05	40.7	1.005	1.001
173.	12	1.004	0.4378	0.9986	1.0002	0.9913	0.0	0.0	0.254	-3.02	40.7	1.004	1.001
183.	13	1.003	0.4374	0.9976	0.9995	0.9914	0.0	0.0	0.256	-2.99	40.7	1.003	1.001
193.	14	1.002	0.4367	0.9967	0.9983	0.9921	0.0	0.0	0.258	-2.94	40.6	1.002	1.000
203.	15	1.001	0.4357	0.9967	0.9971	0.9937	0.0	0.0	0.260	-2.88	40.6	1.001	1.000
213.	16	0.999	0.4346	0.9955	0.9958	0.9960	0.0	0.0	0.262	-2.82	40.5	0.999	1.000
223.	17	0.998	0.4334	0.9953	0.9949	0.9967	0.0	0.0	0.263	-2.77	40.5	0.998	1.000
233.	18	0.997	0.4323	0.9955	0.9944	1.0013	0.0	0.0	0.265	-2.72	40.4	0.997	0.999
243.	19	0.995	0.4313	0.9959	0.9943	1.0033	0.0	0.0	0.266	-2.67	40.4	0.995	0.999
253.	20	0.994	0.4304	0.9963	0.9942	1.0047	0.0	0.0	0.267	-2.62	40.3	0.994	0.999
263.	21	0.993	0.4298	0.9962	0.9937	1.0056	0.0	0.0	0.268	-2.58	40.3	0.993	0.999
273.	22	0.993	0.4293	0.9961	0.9933	1.0063	0.0	0.0	0.269	-2.55	40.3	0.993	0.999
283.	23	0.992	0.4289	0.9958	0.9928	1.0069	0.0	0.0	0.269	-2.53	40.2	0.992	0.999
293.	24	0.991	0.4286	0.9955	0.9923	1.0075	0.0	0.0	0.270	-2.51	40.2	0.991	0.998
303.	25	0.991	0.4283	0.9954	0.9921	1.0081	0.0	0.0	0.270	-2.50	40.2	0.991	0.998
313.	26	0.991	0.4282	0.9955	0.9921	1.0086	0.0	0.0	0.270	-2.50	40.2	0.991	0.998
323.	27	0.992	0.4284	0.9964	0.9931	1.0093	0.0	0.0	0.269	-2.53	40.2	0.992	0.999
333.	28	0.994	0.4291	0.9991	0.9961	1.0102	0.0	0.0	0.266	-2.60	40.3	0.994	0.999
343.	29	0.996	0.4301	0.9998	0.9974	1.0099	0.0	0.0	0.262	-2.69	40.4	0.996	0.999
353.	30	0.997	0.4309	1.0009	0.9990	1.0091	0.0	0.0	0.261	-2.75	40.4	0.997	1.000
1.	31	0.999	0.4316	1.0017	1.0003	1.0078	0.0	0.0	0.259	-2.81	40.5	0.999	1.000
11.	32	1.000	0.4326	1.0029	1.0020	1.0064	0.0	0.0	0.257	-2.85	40.6	1.000	1.000
21.	33	1.001	0.4334	1.0043	1.0039	1.0045	0.0	0.0	0.256	-2.89	40.6	1.001	1.000
31.	34	1.002	0.4343	1.0052	1.0053	1.0018	0.0	0.0	0.255	-2.91	40.6	1.002	1.000
41.	35	1.002	0.4354	1.0055	1.0062	0.9988	0.0	0.0	0.254	-2.95	40.6	1.002	1.000
51.	36	1.003	0.4363	1.0053	1.0066	0.9963	0.0	0.0	0.254	-2.99	40.7	1.003	1.001

APPENDIX B (Cont'd)

STATOR

FLOW SWIRL = 53.55DEG PARTICLE SWIRL = 139.30DEG PSAVG = 35.21PSIA = 242737.PA
 PTAVG = 42.02PSIA = 289723.PA TTAVG = 935.90DEG R = 519.90DEG K VELAVG = 745.0FPS = 227.1MPS
 RVELAVG = 729.5FPS = 227.4MPS AXVELAVG = 570.8FPS = 174.0MPS U = 933.FPS = 284.MPS

THETA	SEG NO	VEL	MN	PS	PT	TT	WBL LBM/SEC	WBL KG/SEC	DF	INCIDENCE IN DEG	ALPHA IN DEG	AXIAL VEL	REL VEL
64.	1	1.002	0.5142	1.0036	1.0057	0.9950	0.004	0.002	0.207	-4.34	50.3	1.006	1.006
74.	2	1.002	0.5144	1.0029	1.0047	0.9939	0.004	0.002	0.206	-4.39	50.4	1.007	1.007
84.	3	1.002	0.5145	1.0026	1.0045	0.9934	0.004	0.002	0.205	-4.42	50.4	1.008	1.008
94.	4	1.002	0.5144	1.0028	1.0046	0.9935	0.004	0.002	0.205	-4.44	50.4	1.008	1.008
104.	5	1.002	0.5144	1.0030	1.0048	0.9936	0.004	0.002	0.204	-4.45	50.5	1.008	1.008
114.	6	1.002	0.5143	1.0032	1.0049	0.9938	0.004	0.002	0.204	-4.46	50.5	1.008	1.008
124.	7	1.002	0.5142	1.0032	1.0049	0.9940	0.004	0.002	0.204	-4.46	50.5	1.008	1.008
134.	8	1.002	0.5142	1.0033	1.0049	0.9941	0.004	0.002	0.204	-4.45	50.5	1.008	1.008
144.	9	1.001	0.5143	1.0017	1.0034	0.9935	0.003	0.001	0.205	-4.41	50.4	1.007	1.007
154.	10	1.001	0.5144	1.0005	1.0022	0.9927	0.002	0.001	0.207	-4.36	50.4	1.006	1.006
164.	11	1.001	0.5144	0.9998	1.0016	0.9920	0.001	0.001	0.208	-4.29	50.3	1.005	1.005
174.	12	1.001	0.5144	0.9988	1.0006	0.9915	0.001	0.000	0.209	-4.24	50.2	1.004	1.004
184.	13	1.000	0.5142	0.9980	0.9997	0.9915	-0.000	-0.000	0.211	-4.18	50.2	1.003	1.003
194.	14	1.000	0.5137	0.9976	0.9989	0.9920	-0.002	-0.001	0.213	-4.08	50.1	1.001	1.001
204.	15	0.999	0.5130	0.9973	0.9981	0.9933	-0.003	-0.001	0.215	-3.97	50.0	0.999	0.999
214.	16	0.998	0.5122	0.9968	0.9970	0.9953	-0.004	-0.002	0.217	-3.87	49.9	0.997	0.997
224.	17	0.998	0.5113	0.9966	0.9962	0.9979	-0.005	-0.002	0.219	-3.78	49.8	0.996	0.996
234.	18	0.998	0.5104	0.9966	0.9958	1.0005	-0.005	-0.002	0.220	-3.73	49.7	0.995	0.995
244.	19	0.998	0.5101	0.9972	0.9959	1.0028	-0.005	-0.002	0.222	-3.66	49.7	0.994	0.994
254.	20	0.998	0.5095	0.9977	0.9961	1.0044	-0.005	-0.002	0.223	-3.60	49.6	0.993	0.993
264.	21	0.998	0.5092	0.9976	0.9958	1.0055	-0.005	-0.002	0.224	-3.55	49.6	0.992	0.992
274.	22	0.998	0.5090	0.9975	0.9956	1.0063	-0.005	-0.002	0.225	-3.52	49.5	0.991	0.991
284.	23	0.998	0.5088	0.9972	0.9952	1.0069	-0.005	-0.002	0.225	-3.48	49.5	0.990	0.990
294.	24	0.998	0.5087	0.9970	0.9948	1.0075	-0.005	-0.002	0.226	-3.46	49.5	0.990	0.990
304.	25	0.998	0.5085	0.9969	0.9946	1.0081	-0.005	-0.002	0.226	-3.44	49.4	0.990	0.990
314.	26	0.998	0.5084	0.9968	0.9944	1.0087	-0.005	-0.002	0.226	-3.45	49.4	0.990	0.990
324.	27	0.998	0.5085	0.9971	0.9948	1.0093	-0.004	-0.002	0.224	-3.53	49.5	0.991	0.991
334.	28	0.999	0.5088	0.9989	0.9968	1.0101	-0.002	-0.001	0.221	-3.67	49.7	0.994	0.994
344.	29	1.000	0.5093	0.9988	0.9971	1.0098	0.001	0.000	0.218	-3.83	49.8	0.997	0.997
354.	30	1.000	0.5096	1.0000	0.9984	1.0092	0.002	0.001	0.216	-3.92	49.9	0.998	0.998
4.	31	1.001	0.5102	1.0006	0.9994	1.0081	0.003	0.002	0.213	-4.02	50.0	1.000	1.000
14.	32	1.001	0.5107	1.0017	1.0009	1.0068	0.004	0.002	0.212	-4.09	50.1	1.001	1.001
24.	33	1.001	0.5112	1.0033	1.0028	1.0051	0.004	0.002	0.211	-4.15	50.1	1.002	1.002
34.	34	1.002	0.5120	1.0043	1.0044	1.0028	0.004	0.002	0.210	-4.19	50.2	1.003	1.003
44.	35	1.002	0.5129	1.0047	1.0054	0.9999	0.004	0.002	0.209	-4.24	50.2	1.004	1.004
54.	36	1.002	0.5136	1.0045	1.0057	0.9972	0.004	0.002	0.208	-4.28	50.3	1.005	1.005

STAGE 13 ROTNR

FLOW SWIRL = 56.52DEG PARTICLE SWIRL = 142.35DEG PSAVG = 36.66PSIA = 252761.PA
 PTAVG = 41.98PSIA = 289414.PA TTAVG = 935.90DEG R = 519.90DEG K VELAVG = 653.6FPS = 199.2MPS
 RVELAVG = 859.6FPS = 262.6MPS AXVELAVG = 579.6FPS = 176.6MPS U = 937.FPS = 286.MPS

THETA	SEG NO	VEL	MN	PS	PT	TT	WBL LBM/SEC	WBL KG/SEC	DF	INCIDENCE IN DEG	BETA IN DEG	AXIAL VEL	REL VEL
67.	1	1.001	0.4482	1.0044	1.0055	0.9950	0.0	0.0	0.271	-7.46	42.5	1.001	1.000
77.	2	1.002	0.4489	1.0037	1.0052	0.9939	0.0	0.0	0.270	-7.50	42.5	1.002	1.000
87.	3	1.003	0.4493	1.0033	1.0050	0.9934	0.0	0.0	0.270	-7.53	42.5	1.003	1.001
97.	4	1.003	0.4495	1.0034	1.0052	0.9935	0.0	0.0	0.270	-7.54	42.5	1.003	1.001
107.	5	1.004	0.4496	1.0036	1.0054	0.9936	0.0	0.0	0.269	-7.55	42.6	1.004	1.001
117.	6	1.004	0.4496	1.0037	1.0056	0.9937	0.0	0.0	0.269	-7.56	42.6	1.004	1.001
127.	7	1.004	0.4496	1.0037	1.0056	0.9941	0.0	0.0	0.269	-7.56	42.6	1.004	1.001
137.	8	1.004	0.4496	1.0037	1.0056	0.9941	0.0	0.0	0.269	-7.56	42.6	1.004	1.001
147.	9	1.004	0.4496	1.0022	1.0041	0.9935	0.0	0.0	0.269	-7.56	42.6	1.004	1.001
157.	10	1.004	0.4497	1.0009	1.0029	0.9927	0.0	0.0	0.270	-7.55	42.5	1.004	1.001
167.	11	1.003	0.4497	1.0003	1.0023	0.9920	0.0	0.0	0.270	-7.53	42.5	1.003	1.001
177.	12	1.003	0.4498	0.9992	1.0013	0.9915	0.0	0.0	0.270	-7.53	42.5	1.003	1.001
187.	13	1.003	0.4498	0.9983	1.0003	0.9915	0.0	0.0	0.270	-7.53	42.5	1.003	1.001
197.	14	1.003	0.4497	0.9973	0.9993	0.9920	0.0	0.0	0.270	-7.53	42.5	1.003	1.001
207.	15	1.003	0.4494	0.9964	0.9982	0.9933	0.0	0.0	0.271	-7.53	42.5	1.003	1.001
217.	16	1.003	0.4487	0.9956	0.9969	0.9953	0.0	0.0	0.272	-7.51	42.5	1.003	1.001
227.	17	1.002	0.4478	0.9952	0.9960	0.9979	0.0	0.0	0.273	-7.48	42.5	1.002	1.000
237.	18	1.001	0.4468	0.9952	0.9954	1.0005	0.0	0.0	0.274	-7.44	42.4	1.001	1.000
247.	19	1.000	0.4458	0.9958	0.9954	1.0028	0.0	0.0	0.275	-7.40	42.4	1.000	1.000
257.	20	0.999	0.4449	0.9964	0.9954	1.0044	0.0	0.0	0.276	-7.35	42.3	0.999	1.000
267.	21	0.998	0.4442	0.9964	0.9951	1.0055	0.0	0.0	0.277	-7.31	42.3	0.998	1.000
277.	22	0.997	0.4437	0.9964	0.9948	1.0063	0.0	0.0	0.278	-7.28	42.3	0.997	0.999
287.	23	0.997	0.4433	0.9962	0.9943	1.0069	0.0	0.0	0.278	-7.26	42.3	0.997	0.999
297.	24	0.996	0.4429	0.9959	0.9938	1.0075	0.0	0.0	0.279	-7.23	42.2	0.996	0.999
307.	25	0.996	0.4427	0.9959	0.9936	1.0081	0.0	0.0	0.279	-7.22	42.2	0.996	0.999
317.	26	0.996	0.4424	0.9959	0.9934	1.0087	0.0	0.0	0.279	-7.21	42.2	0.996	0.999
327.	27	0.995	0.4422	0.9966	0.9940	1.0093	0.0	0.0	0.280	-7.20	42.2	0.995	0.999
337.	28	0.995	0.4421	0.9990	0.9944	1.0101	0.0	0.0	0.279	-7.20	42.2	0.995	0.999
347.	29	0.995	0.4421	0.9996	0.9970	1.0098	0.0	0.0	0.279	-7.20	42.2	0.995	0.999
357.	30	0.995	0.4423	1.0009	0.9984	1.0092	0.0	0.0	0.279	-7.21	42.2	0.995	0.999
7.	31	0.996	0.4427	1.0016	0.9993	1.0081	0.0	0.0	0.278	-7.22	42.2	0.996	0.999
17.	32	0.996	0.4432	1.0028	1.0009	1.0068	0.0	0.0	0.277	-7.24	42.2	0.996	0.999
27.	33	0.997	0.4440	1.0043	1.0028	1.0051	0.0	0.0	0.276	-7.28	42.3	0.997	0.999
37.	34	0.998	0.4449	1.0054	1.0044	1.0028	0.0	0.0	0.275	-7.31	42.3	0.998	1.000
47.	35	0.999	0.4460	1.0058	1.0055	0.9999	0.0	0.0	0.273	-7.36	42.4	0.999	1.000
57.	36	1.000	0.4472	1.0055	1.0059	0.9972	0.0	0.0	0.272	-7.41	42.4	1.000	1.000

APPENDIX B (Cont'd)

STATOR

FLOW SWIRL= 57.39DEG PARTICLE SWIRL=147.49DEG PSAVG= 39.90PSIA = 275090.PA
 PTAVG= 48.11PSIA = 331679.PA TTAVG= 980.3DEG R = 544.6DEG K VELAVG= 783.5FPS = 238.8MPS
 RVELAVG= 723.6FPS = 220.5MPS AXVELAVG= 587.1FPS = 179.0MPS U= 942.FPS = 287.MPS

THETA	SEG NO	VEL	MN	PS	PT	TT	MBL LBM/SEC	MBL KG/SEC	DF	INCIDENCE IN DEG	BETA IN DEG	AXIAL VEL	REL VEL
67.	1	1.001	0.5289	1.0042	1.0055	0.9959	0.0	0.0	0.281	-3.16	46.7	1.002	1.002
77.	2	1.001	0.5293	1.0033	1.0049	0.9944	0.0	0.0	0.281	-3.20	46.7	1.003	1.003
87.	3	1.001	0.5294	1.0029	1.0045	0.9937	0.0	0.0	0.280	-3.22	46.7	1.004	1.004
97.	4	1.001	0.5293	1.0030	1.0046	0.9935	0.0	0.0	0.280	-3.23	46.7	1.004	1.004
107.	5	1.001	0.5293	1.0031	1.0047	0.9936	0.0	0.0	0.280	-3.25	46.7	1.004	1.004
117.	6	1.001	0.5292	1.0032	1.0047	0.9938	0.0	0.0	0.279	-3.25	46.8	1.004	1.004
127.	7	1.001	0.5292	1.0032	1.0047	0.9939	0.0	0.0	0.279	-3.25	46.8	1.004	1.004
137.	8	1.001	0.5292	1.0032	1.0047	0.9940	0.0	0.0	0.279	-3.26	46.8	1.004	1.004
147.	9	1.001	0.5293	1.0018	1.0034	0.9936	0.0	0.0	0.279	-3.25	46.8	1.004	1.004
157.	10	1.001	0.5295	1.0007	1.0024	0.9936	0.0	0.0	0.280	-3.24	46.7	1.004	1.004
167.	11	1.001	0.5296	1.0004	1.0022	0.9924	0.0	0.0	0.280	-3.22	46.7	1.004	1.004
177.	12	1.001	0.5297	0.9994	1.0013	0.9918	0.0	0.0	0.281	-3.21	46.7	1.003	1.003
187.	13	1.001	0.5297	0.9984	1.0002	0.9916	0.0	0.0	0.281	-3.20	46.7	1.003	1.003
197.	14	1.000	0.5295	0.9973	0.9990	0.9919	0.0	0.0	0.281	-3.19	46.7	1.003	1.003
207.	15	1.000	0.5291	0.9963	0.9977	0.9928	0.0	0.0	0.281	-3.18	46.7	1.003	1.003
217.	16	1.000	0.5283	0.9955	0.9964	0.9944	0.0	0.0	0.282	-3.13	46.6	1.002	1.002
227.	17	0.999	0.5275	0.9951	0.9954	0.9967	0.0	0.0	0.283	-3.08	46.6	1.001	1.001
237.	18	0.999	0.5267	0.9952	0.9949	0.9993	0.0	0.0	0.284	-3.03	46.5	1.000	1.000
247.	19	0.999	0.5260	0.9958	0.9950	1.0018	0.0	0.0	0.285	-2.98	46.5	0.999	0.999
257.	20	0.999	0.5254	0.9967	0.9955	1.0037	0.0	0.0	0.286	-2.92	46.4	0.998	0.998
267.	21	0.999	0.5251	0.9968	0.9954	1.0050	0.0	0.0	0.287	-2.87	46.4	0.997	0.997
277.	22	0.999	0.5248	0.9968	0.9952	1.0059	0.0	0.0	0.287	-2.84	46.3	0.996	0.996
287.	23	0.999	0.5247	0.9965	0.9948	1.0065	0.0	0.0	0.288	-2.82	46.3	0.996	0.996
297.	24	0.999	0.5244	0.9964	0.9945	1.0072	0.0	0.0	0.288	-2.79	46.3	0.995	0.995
307.	25	0.999	0.5243	0.9963	0.9943	1.0078	0.0	0.0	0.289	-2.77	46.3	0.995	0.995
317.	26	0.999	0.5241	0.9962	0.9941	1.0084	0.0	0.0	0.289	-2.77	46.3	0.995	0.995
327.	27	0.999	0.5240	0.9970	0.9948	1.0090	0.0	0.0	0.289	-2.76	46.3	0.995	0.995
337.	28	0.999	0.5239	0.9992	0.9969	1.0099	0.0	0.0	0.289	-2.77	46.3	0.995	0.995
347.	29	0.999	0.5240	0.9998	0.9976	1.0098	0.0	0.0	0.288	-2.79	46.3	0.995	0.995
357.	30	0.999	0.5242	1.0011	0.9990	1.0095	0.0	0.0	0.288	-2.80	46.3	0.995	0.995
7.	31	1.000	0.5246	1.0018	1.0000	1.0085	0.0	0.0	0.287	-2.83	46.3	0.996	0.996
17.	32	1.000	0.5251	1.0029	1.0015	1.0074	0.0	0.0	0.287	-2.86	46.4	0.997	0.997
27.	33	1.000	0.5257	1.0043	1.0033	1.0059	0.0	0.0	0.286	-2.92	46.4	0.998	0.998
37.	34	1.001	0.5265	1.0053	1.0049	1.0038	0.0	0.0	0.284	-2.98	46.5	0.999	0.999
47.	35	1.001	0.5275	1.0057	1.0059	1.0012	0.0	0.0	0.283	-3.05	46.5	1.000	1.000
57.	36	1.001	0.5283	1.0053	1.0062	0.9984	0.0	0.0	0.282	-3.11	46.6	1.001	1.001

STAGE 14 ROTOR

FLOW SWIRL= 60.45DEG PARTICLE SWIRL=150.55DEG PSAVG= 42.58PSIA = 293600.PA
 PTAVG= 48.31PSIA = 333055.PA TTAVG= 980.3DEG R = 544.6DEG K VELAVG= 645.9FPS = 196.9MPS
 RVELAVG= 879.6FPS = 268.1MPS AXVELAVG= 580.2FPS = 176.8MPS U= 945.FPS = 288.MPS

THETA	SEG NO	VEL	MN	PS	PT	TT	MBL LBM/SEC	MBL KG/SEC	DF	INCIDENCE IN DEG	BETA IN DEG	AXIAL VEL	REL VEL
70.	1	1.002	0.4328	1.0043	1.0054	0.9959	0.0	0.0	0.252	-4.36	41.4	1.002	1.000
80.	2	1.003	0.4335	1.0034	1.0049	0.9944	0.0	0.0	0.252	-4.40	41.4	1.003	1.001
90.	3	1.004	0.4338	1.0030	1.0047	0.9937	0.0	0.0	0.252	-4.41	41.4	1.004	1.001
100.	4	1.004	0.4340	1.0030	1.0049	0.9935	0.0	0.0	0.252	-4.42	41.4	1.004	1.001
110.	5	1.004	0.4341	1.0031	1.0050	0.9936	0.0	0.0	0.252	-4.43	41.4	1.004	1.001
120.	6	1.004	0.4341	1.0032	1.0050	0.9938	0.0	0.0	0.251	-4.44	41.4	1.004	1.001
130.	7	1.004	0.4341	1.0032	1.0050	0.9939	0.0	0.0	0.251	-4.44	41.4	1.004	1.001
140.	8	1.004	0.4342	1.0031	1.0050	0.9940	0.0	0.0	0.251	-4.45	41.4	1.004	1.001
150.	9	1.004	0.4342	1.0018	1.0037	0.9936	0.0	0.0	0.251	-4.44	41.4	1.004	1.001
160.	10	1.004	0.4342	1.0008	1.0027	0.9930	0.0	0.0	0.252	-4.43	41.4	1.004	1.001
170.	11	1.003	0.4340	1.0006	1.0024	0.9924	0.0	0.0	0.253	-4.41	41.4	1.003	1.001
180.	12	1.003	0.4340	0.9997	1.0015	0.9918	0.0	0.0	0.253	-4.39	41.4	1.003	1.001
190.	13	1.003	0.4340	0.9987	1.0005	0.9916	0.0	0.0	0.253	-4.38	41.4	1.003	1.001
200.	14	1.003	0.4339	0.9976	0.9993	0.9919	0.0	0.0	0.254	-4.38	41.4	1.003	1.001
210.	15	1.002	0.4336	0.9966	0.9981	0.9928	0.0	0.0	0.254	-4.37	41.4	1.002	1.000
220.	16	1.002	0.4328	0.9957	0.9969	0.9944	0.0	0.0	0.256	-4.33	41.3	1.002	1.000
230.	17	1.001	0.4319	0.9952	0.9958	0.9967	0.0	0.0	0.257	-4.30	41.3	1.001	1.000
240.	18	1.000	0.4310	0.9952	0.9952	0.9993	0.0	0.0	0.258	-4.26	41.3	1.000	1.000
250.	19	0.999	0.4300	0.9958	0.9953	1.0018	0.0	0.0	0.259	-4.23	41.2	0.999	1.000
260.	20	0.998	0.4291	0.9966	0.9956	1.0037	0.0	0.0	0.260	-4.18	41.2	0.998	1.000
270.	21	0.997	0.4285	0.9968	0.9954	1.0050	0.0	0.0	0.261	-4.14	41.1	0.997	0.999
280.	22	0.996	0.4280	0.9968	0.9951	1.0059	0.0	0.0	0.262	-4.12	41.1	0.996	0.999
290.	23	0.996	0.4277	0.9965	0.9946	1.0065	0.0	0.0	0.262	-4.10	41.1	0.996	0.999
300.	24	0.995	0.4272	0.9964	0.9943	1.0072	0.0	0.0	0.263	-4.08	41.1	0.995	0.999
310.	25	0.995	0.4270	0.9963	0.9940	1.0078	0.0	0.0	0.263	-4.06	41.1	0.995	0.999
320.	26	0.995	0.4268	0.9962	0.9938	1.0084	0.0	0.0	0.263	-4.06	41.1	0.995	0.999
330.	27	0.995	0.4266	0.9969	0.9944	1.0090	0.0	0.0	0.263	-4.05	41.1	0.995	0.999
340.	28	0.995	0.4266	0.9990	0.9965	1.0099	0.0	0.0	0.262	-4.07	41.1	0.995	0.999
350.	29	0.995	0.4267	0.9996	0.9971	1.0098	0.0	0.0	0.262	-4.08	41.1	0.995	0.999
0.	30	0.996	0.4269	1.0009	0.9986	1.0095	0.0	0.0	0.261	-4.09	41.1	0.996	0.999
10.	31	0.996	0.4274	1.0016	0.9995	1.0085	0.0	0.0	0.260	-4.12	41.1	0.996	0.999
20.	32	0.997	0.4279	1.0027	1.0010	1.0074	0.0	0.0	0.259	-4.19	41.2	0.998	1.000
30.	33	0.998	0.4288	1.0041	1.0028	1.0059	0.0	0.0	0.258	-4.24	41.2	0.999	1.000
40.	34	0.999	0.4297	1.0052	1.0045	1.0038	0.0	0.0	0.256	-4.24	41.2	0.999	1.000
50.	35	1.000	0.4308	1.0056	1.0055	1.0012	0.0	0.0	0.254	-4.29	41.3	1.000	1.000
60.	36	1.001	0.4319	1.0053	1.0059	0.9984	0.0	0.0	0.253	-4.33	41.3	1.001	1.000

APPENDIX B (Cont'd)

STATOR

FLOW SWIRL= 61.62DEG PARTICLE SWIRL=156.17DEG PSAVG= 45.08PSIA = 310786.PA
PTAVG= 53.79PSIA = 370881.PA TTAVG=1022.8DEG R = 568.2DEG K VELAVG= 778.6FPS =237.3MPS
RVELAVG= 746.7FPS = 227.6MPS AXVELAVG= 596.8FPS =181.9MPS U= 949.FPS = 289.MPS

THETA	SEG NO	VEL	MW	PS	PT	TT	MBL LBM/SEC	WBL KG/SEC	DF	INCIDENCE IN DEG	BETA IN DEG	AXIAL VEL	REL VEL
72.	1	1.002	0.5142	1.0037	1.0049	0.9968	0.0	0.0	0.292	-4.75	50.2	1.004	1.004
82.	2	1.002	0.5146	1.0028	1.0043	0.9949	0.0	0.0	0.292	-4.77	50.3	1.004	1.004
92.	3	1.001	0.5147	1.0024	1.0040	0.9939	0.0	0.0	0.292	-4.78	50.3	1.004	1.004
102.	4	1.001	0.5147	1.0025	1.0040	0.9936	0.0	0.0	0.292	-4.78	50.3	1.004	1.004
112.	5	1.001	0.5147	1.0025	1.0040	0.9935	0.0	0.0	0.292	-4.79	50.3	1.005	1.005
122.	6	1.001	0.5146	1.0025	1.0040	0.9936	0.0	0.0	0.291	-4.80	50.3	1.005	1.005
132.	7	1.001	0.5146	1.0025	1.0040	0.9938	0.0	0.0	0.291	-4.80	50.3	1.005	1.005
142.	8	1.001	0.5146	1.0023	1.0039	0.9939	0.0	0.0	0.291	-4.81	50.3	1.005	1.005
152.	9	1.001	0.5147	1.0017	1.0028	0.9936	0.0	0.0	0.291	-4.80	50.3	1.005	1.005
162.	10	1.001	0.5148	1.0004	1.0021	0.9932	0.0	0.0	0.293	-4.74	50.2	1.004	1.004
172.	11	1.001	0.5148	1.0006	1.0022	0.9928	0.0	0.0	0.294	-4.70	50.2	1.003	1.003
182.	12	1.001	0.5149	0.9998	1.0015	0.9921	0.0	0.0	0.293	-4.74	50.2	1.004	1.004
192.	13	1.001	0.5149	0.9989	1.0006	0.9918	0.0	0.0	0.294	-4.70	50.2	1.003	1.003
202.	14	1.000	0.5148	0.9976	0.9993	0.9918	0.0	0.0	0.294	-4.69	50.2	1.003	1.003
212.	15	1.000	0.5144	0.9967	0.9981	0.9924	0.0	0.0	0.294	-4.65	50.2	1.002	1.002
222.	16	0.999	0.5137	0.9961	0.9970	0.9938	0.0	0.0	0.296	-4.58	50.1	1.001	1.001
232.	17	0.999	0.5129	0.9956	0.9960	0.9958	0.0	0.0	0.297	-4.52	50.0	1.000	1.000
242.	18	0.999	0.5121	0.9956	0.9954	0.9983	0.0	0.0	0.298	-4.46	50.0	0.999	0.999
252.	19	0.999	0.5114	0.9962	0.9955	1.0008	0.0	0.0	0.299	-4.42	49.9	0.998	0.998
262.	20	0.998	0.5108	0.9972	0.9961	1.0030	0.0	0.0	0.299	-4.36	49.9	0.997	0.997
272.	21	0.999	0.5105	0.9975	0.9961	1.0045	0.0	0.0	0.300	-4.32	49.8	0.996	0.996
282.	22	0.999	0.5102	0.9974	0.9959	1.0055	0.0	0.0	0.301	-4.30	49.8	0.995	0.995
292.	23	0.999	0.5100	0.9972	0.9955	1.0063	0.0	0.0	0.301	-4.27	49.8	0.995	0.995
302.	24	0.998	0.5098	0.9972	0.9954	1.0070	0.0	0.0	0.302	-4.23	49.7	0.994	0.994
312.	25	0.998	0.5096	0.9970	0.9951	1.0076	0.0	0.0	0.302	-4.22	49.7	0.994	0.994
322.	26	0.998	0.5095	0.9969	0.9948	1.0082	0.0	0.0	0.302	-4.22	49.7	0.994	0.994
332.	27	0.999	0.5094	0.9976	0.9954	1.0088	0.0	0.0	0.302	-4.22	49.7	0.994	0.994
342.	28	0.999	0.5093	0.9993	0.9971	1.0097	0.0	0.0	0.301	-4.26	49.7	0.995	0.995
352.	29	0.999	0.5094	0.9998	0.9977	1.0098	0.0	0.0	0.301	-4.28	49.8	0.995	0.995
2.	30	0.999	0.5096	1.0011	0.9991	1.0097	0.0	0.0	0.300	-4.31	49.8	0.996	0.996
12.	31	1.000	0.5100	1.0016	0.9999	1.0080	0.0	0.0	0.299	-4.36	49.9	0.997	0.997
22.	32	1.000	0.5104	1.0026	1.0012	1.0079	0.0	0.0	0.298	-4.41	49.9	0.997	0.997
32.	33	1.001	0.5111	1.0037	1.0027	1.0065	0.0	0.0	0.297	-4.49	50.0	0.999	0.999
42.	34	1.001	0.5118	1.0046	1.0042	1.0047	0.0	0.0	0.295	-4.57	50.1	1.001	1.001
52.	35	1.002	0.5127	1.0049	1.0051	1.0022	0.0	0.0	0.294	-4.66	50.2	1.002	1.002
62.	36	1.002	0.5135	1.0047	1.0055	0.9995	0.0	0.0	0.293	-4.71	50.2	1.003	1.003

STAGE 15 ROTOR

FLOW SWIRL= 64.30DEG PARTICLE SWIRL=156.85DEG PSAVG= 48.34PSIA = 333285.PA
PTAVG= 54.32PSIA = 374531.PA TTAVG=1022.8DEG R = 568.2DEG K VELAVG= 635.1FPS =193.6MPS
RVELAVG= 917.8FPS = 279.7MPS AXVELAVG= 585.8FPS =178.6MPS U= 952.FPS = 290.MPS

THETA	SEG NO	VEL	MW	PS	PT	TT	MBL LBM/SEC	WBL KG/SEC	DF	INCIDENCE IN DEG	BETA IN DEG	AXIAL VEL	REL VEL
74.	1	1.004	0.4169	1.0035	1.0048	0.9968	0.0	0.0	0.246	-5.92	39.8	1.004	1.001
84.	2	1.004	0.4175	1.0027	1.0044	0.9949	0.0	0.0	0.246	-5.93	39.8	1.004	1.001
94.	3	1.004	0.4177	1.0024	1.0042	0.9939	0.0	0.0	0.247	-5.93	39.8	1.004	1.001
104.	4	1.004	0.4176	1.0025	1.0043	0.9936	0.0	0.0	0.247	-5.94	39.8	1.004	1.001
114.	5	1.005	0.4179	1.0024	1.0043	0.9935	0.0	0.0	0.246	-5.94	39.8	1.005	1.001
124.	6	1.005	0.4179	1.0025	1.0043	0.9936	0.0	0.0	0.246	-5.95	39.8	1.005	1.001
134.	7	1.005	0.4179	1.0024	1.0043	0.9938	0.0	0.0	0.246	-5.95	39.9	1.005	1.001
144.	8	1.005	0.4180	1.0023	1.0042	0.9938	0.0	0.0	0.246	-5.96	39.9	1.005	1.001
154.	9	1.005	0.4180	1.0012	1.0031	0.9936	0.0	0.0	0.246	-5.95	39.8	1.005	1.001
164.	10	1.005	0.4179	1.0005	1.0023	0.9932	0.0	0.0	0.247	-5.94	39.8	1.005	1.001
174.	11	1.004	0.4176	1.0008	1.0025	0.9928	0.0	0.0	0.248	-5.90	39.8	1.004	1.001
184.	12	1.003	0.4175	1.0000	1.0017	0.9921	0.0	0.0	0.249	-5.88	39.8	1.003	1.001
194.	13	1.003	0.4174	0.9992	1.0008	0.9918	0.0	0.0	0.250	-5.86	39.8	1.003	1.001
204.	14	1.002	0.4173	0.9980	0.9995	0.9918	0.0	0.0	0.250	-5.86	39.8	1.002	1.000
214.	15	1.002	0.4168	0.9971	0.9984	0.9924	0.0	0.0	0.251	-5.83	39.7	1.002	1.000
224.	16	1.000	0.4160	0.9966	0.9973	0.9938	0.0	0.0	0.253	-5.78	39.7	1.000	1.000
234.	17	0.999	0.4151	0.9960	0.9963	0.9958	0.0	0.0	0.255	-5.73	39.6	0.999	1.000
244.	18	0.998	0.4141	0.9959	0.9957	0.9983	0.0	0.0	0.256	-5.70	39.6	0.998	1.000
254.	19	0.997	0.4133	0.9964	0.9957	1.0008	0.0	0.0	0.257	-5.67	39.6	0.997	0.999
264.	20	0.997	0.4125	0.9973	0.9961	1.0030	0.0	0.0	0.258	-5.64	39.5	0.997	0.999
274.	21	0.996	0.4118	0.9976	0.9960	1.0045	0.0	0.0	0.258	-5.61	39.5	0.996	0.999
284.	22	0.995	0.4114	0.9975	0.9957	1.0055	0.0	0.0	0.259	-5.59	39.5	0.995	0.999
294.	23	0.995	0.4111	0.9972	0.9953	1.0063	0.0	0.0	0.259	-5.57	39.5	0.995	0.999
304.	24	0.994	0.4107	0.9973	0.9951	1.0071	0.0	0.0	0.260	-5.55	39.4	0.994	0.999
314.	25	0.994	0.4105	0.9971	0.9948	1.0076	0.0	0.0	0.260	-5.54	39.4	0.994	0.999
324.	26	0.994	0.4103	0.9969	0.9945	1.0082	0.0	0.0	0.260	-5.54	39.4	0.994	0.999
334.	27	0.994	0.4102	0.9975	0.9950	1.0088	0.0	0.0	0.260	-5.54	39.4	0.994	0.999
344.	28	0.995	0.4104	0.9991	0.9967	1.0097	0.0	0.0	0.258	-5.57	39.5	0.995	0.999
354.	29	0.995	0.4106	0.9995	0.9973	1.0098	0.0	0.0	0.257	-5.59	39.5	0.995	0.999
4.	30	0.996	0.4109	1.0008	0.9987	1.0097	0.0	0.0	0.257	-5.61	39.5	0.996	0.999
14.	31	0.997	0.4114	1.0013	0.9995	1.0088	0.0	0.0	0.255	-5.65	39.5	0.997	0.999
24.	32	0.998	0.4120	1.0023	1.0008	1.0079	0.0	0.0	0.254	-5.68	39.6	0.998	1.000
34.	33	0.999	0.4130	1.0033	1.0023	1.0065	0.0	0.0	0.251	-5.75	39.6	0.999	1.000
44.	34	1.001	0.4140	1.0042	1.0039	1.0047	0.0	0.0	0.249	-5.80	39.7	1.001	1.000
54.	35	1.002	0.4152	1.0045	1.0048	1.0022	0.0	0.0	0.247	-5.86	39.8	1.002	1.000
64.	36	1.003	0.4161	1.0044	1.0053	0.9995	0.0	0.0	0.246	-5.90	39.8	1.003	1.001

APPENDIX B (Cont'd)

STATOR

FLOW SWIRL= 64.41DEG PARTICLE SWIRL=162.53DEG PSAVG= 52.31PSIA = 360684.PA
 PTAVG= 60.72PSIA = 418639.PA TTAVG=1061.4DEG R = 589.6DEG K VELAVG= 729.6FPS =222.4MPS
 RVFLAVG= 774.5FPS = 236.1MPS AXVELAVG= 580.7FPS =177.0MPS U= 954.FPS = 291.MPS

THETA	SEG NO	VEL	MN	PS	PT	TT	WBL LBM/SEC	WBL KG/SEC	DF	INCIDENCE IN DEG	ALPHA IN DEG	AXIAL VEL	REL VEL
74.	1	1.002	0.4715	1.0024	1.0034	0.9975	0.0	0.0	0.262	-5.48	53.1	1.006	1.006
84.	2	1.002	0.4718	1.0019	1.0031	0.9954	0.0	0.0	0.262	-5.48	53.1	1.006	1.006
94.	3	1.001	0.4720	1.0018	1.0031	0.9942	0.0	0.0	0.262	-5.46	53.1	1.005	1.005
104.	4	1.001	0.4720	1.0018	1.0032	0.9936	0.0	0.0	0.262	-5.45	53.1	1.005	1.005
114.	5	1.001	0.4721	1.0017	1.0030	0.9935	0.0	0.0	0.262	-5.46	53.1	1.005	1.005
124.	6	1.001	0.4720	1.0017	1.0030	0.9935	0.0	0.0	0.262	-5.47	53.1	1.006	1.006
134.	7	1.001	0.4720	1.0016	1.0030	0.9936	0.0	0.0	0.262	-5.47	53.1	1.006	1.006
144.	8	1.001	0.4720	1.0013	1.0027	0.9937	0.0	0.0	0.262	-5.49	53.1	1.006	1.006
154.	9	1.001	0.4720	1.0005	1.0018	0.9935	0.0	0.0	0.262	-5.47	53.1	1.005	1.005
164.	10	1.001	0.4720	1.0000	1.0013	0.9932	0.0	0.0	0.263	-5.44	53.0	1.005	1.005
174.	11	1.001	0.4719	1.0008	1.0021	0.9930	0.0	0.0	0.264	-5.37	53.0	1.004	1.004
184.	12	1.001	0.4720	1.0002	1.0016	0.9924	0.0	0.0	0.265	-5.33	52.9	1.003	1.003
194.	13	1.000	0.4720	0.9996	1.0010	0.9920	0.0	0.0	0.265	-5.29	52.9	1.002	1.002
204.	14	1.000	0.4720	0.9984	0.9997	0.9919	0.0	0.0	0.266	-5.27	52.9	1.002	1.002
214.	15	1.000	0.4716	0.9978	0.9989	0.9923	0.0	0.0	0.267	-5.20	52.8	1.001	1.001
224.	16	0.999	0.4710	0.9977	0.9984	0.9936	0.0	0.0	0.269	-5.07	52.7	0.999	0.999
234.	17	0.999	0.4704	0.9972	0.9975	0.9953	0.0	0.0	0.271	-4.99	52.6	0.998	0.998
244.	18	0.998	0.4697	0.9970	0.9969	0.9976	0.0	0.0	0.272	-4.93	52.5	0.996	0.996
254.	19	0.998	0.4691	0.9974	0.9966	1.0001	0.0	0.0	0.272	-4.89	52.5	0.996	0.996
264.	20	0.998	0.4685	0.9983	0.9974	1.0025	0.0	0.0	0.273	-4.84	52.4	0.995	0.995
274.	21	0.998	0.4681	0.9986	0.9975	1.0041	0.0	0.0	0.274	-4.80	52.4	0.994	0.994
284.	22	0.998	0.4679	0.9984	0.9971	1.0053	0.0	0.0	0.274	-4.79	52.4	0.994	0.994
294.	23	0.998	0.4677	0.9982	0.9968	1.0061	0.0	0.0	0.275	-4.77	52.4	0.994	0.994
304.	24	0.998	0.4674	0.9985	0.9969	1.0069	0.0	0.0	0.276	-4.71	52.3	0.993	0.993
314.	25	0.998	0.4673	0.9981	0.9964	1.0075	0.0	0.0	0.276	-4.71	52.3	0.993	0.993
324.	26	0.998	0.4673	0.9977	0.9960	1.0080	0.0	0.0	0.275	-4.72	52.3	0.993	0.993
334.	27	0.998	0.4671	0.9983	0.9965	1.0087	0.0	0.0	0.275	-4.72	52.3	0.993	0.993
344.	28	0.999	0.4672	0.9992	0.9975	1.0095	0.0	0.0	0.274	-4.81	52.4	0.994	0.994
354.	29	0.999	0.4672	0.9996	0.9978	1.0097	0.0	0.0	0.273	-4.85	52.4	0.995	0.995
4.	30	0.999	0.4674	1.0007	0.9950	1.0097	0.0	0.0	0.272	-4.90	52.5	0.996	0.996
14.	31	1.000	0.4677	1.0009	0.9995	1.0091	0.0	0.0	0.271	-4.98	52.6	0.997	0.997
24.	32	1.000	0.4681	1.0017	1.0006	1.0081	0.0	0.0	0.269	-5.05	52.7	0.999	0.999
34.	33	1.001	0.4688	1.0021	1.0014	1.0068	0.0	0.0	0.267	-5.19	52.8	1.001	1.001
44.	34	1.001	0.4694	1.0029	1.0025	1.0051	0.0	0.0	0.265	-5.30	52.9	1.003	1.003
54.	35	1.002	0.4702	1.0029	1.0031	1.0028	0.0	0.0	0.263	-5.41	53.0	1.005	1.005
64.	36	1.002	0.4709	1.0031	1.0037	1.0002	0.0	0.0	0.262	-5.46	53.1	1.005	1.005

STAGE 16 ROTOP

FLOW SWIRL= 66.73DEG PARTICLE SWIRL=164.85DEG PSAVG= 54.25PSIA = 374048.PA
 PTAVG= 60.24PSIA = 415332.PA TTAVG=1061.4DEG R = 589.6DEG K VELAVG= 613.4FPS =187.0MPS
 RVFLAVG= 956.3FPS = 291.5MPS AXVELAVG= 581.0FPS =177.1MPS U= 956.FPS = 291.MPS

THETA	SEG NO	VEL	MN	PS	PT	TT	WBL LBM/SEC	WBL KG/SEC	DF	INCIDENCE IN DEG	BETA IN DEG	AXIAL VEL	REL VEL
77.	1	1.006	0.3956	1.0020	1.0036	0.9975	0.0	0.0	0.271	-5.43	37.6	1.006	1.001
87.	2	1.006	0.3960	1.0014	1.0032	0.9954	0.0	0.0	0.272	-5.42	37.6	1.006	1.001
97.	3	1.006	0.3961	1.0014	1.0032	0.9942	0.0	0.0	0.273	-5.41	37.6	1.006	1.001
107.	4	1.006	0.3962	1.0014	1.0033	0.9936	0.0	0.0	0.273	-5.40	37.6	1.006	1.001
117.	5	1.006	0.3963	1.0013	1.0033	0.9935	0.0	0.0	0.273	-5.41	37.6	1.006	1.001
127.	6	1.006	0.3963	1.0012	1.0032	0.9935	0.0	0.0	0.273	-5.42	37.6	1.006	1.001
137.	7	1.006	0.3963	1.0012	1.0032	0.9936	0.0	0.0	0.273	-5.42	37.6	1.006	1.001
147.	8	1.006	0.3965	1.0009	1.0029	0.9937	0.0	0.0	0.273	-5.43	37.6	1.006	1.001
157.	9	1.006	0.3963	1.0001	1.0020	0.9935	0.0	0.0	0.273	-5.41	37.6	1.006	1.001
167.	10	1.005	0.3962	0.9996	1.0015	0.9932	0.0	0.0	0.274	-5.40	37.6	1.005	1.001
177.	11	1.004	0.3957	1.0006	1.0022	0.9930	0.0	0.0	0.276	-5.35	37.6	1.004	1.001
187.	12	1.003	0.3955	1.0000	1.0016	0.9924	0.0	0.0	0.276	-5.33	37.5	1.003	1.001
197.	13	1.003	0.3953	0.9995	1.0009	0.9920	0.0	0.0	0.277	-5.30	37.5	1.003	1.001
207.	14	1.002	0.3952	0.9983	0.9996	0.9919	0.0	0.0	0.278	-5.29	37.5	1.002	1.000
217.	15	1.001	0.3946	0.9978	0.9988	0.9923	0.0	0.0	0.280	-5.25	37.4	1.001	1.000
227.	16	0.999	0.3934	0.9970	0.9983	0.9936	0.0	0.0	0.283	-5.17	37.4	0.999	1.000
237.	17	0.997	0.3925	0.9974	0.9973	0.9953	0.0	0.0	0.285	-5.12	37.3	0.997	0.999
247.	18	0.996	0.3916	0.9973	0.9968	0.9976	0.0	0.0	0.286	-5.08	37.3	0.996	0.999
257.	19	0.996	0.3909	0.9977	0.9967	1.0001	0.0	0.0	0.287	-5.06	37.3	0.996	0.999
267.	20	0.995	0.3900	0.9977	0.9973	1.0025	0.0	0.0	0.288	-5.03	37.2	0.995	0.999
277.	21	0.994	0.3894	0.9990	0.9973	1.0041	0.0	0.0	0.288	-5.00	37.2	0.994	0.999
287.	22	0.994	0.3891	0.9989	0.9970	1.0053	0.0	0.0	0.288	-4.99	37.2	0.994	0.999
297.	23	0.993	0.3888	0.9986	0.9966	1.0061	0.0	0.0	0.288	-4.98	37.2	0.993	0.999
307.	24	0.992	0.3883	0.9990	0.9967	1.0069	0.0	0.0	0.289	-4.95	37.1	0.992	0.998
317.	25	0.992	0.3882	0.9986	0.9962	1.0075	0.0	0.0	0.289	-4.95	37.1	0.992	0.998
327.	26	0.993	0.3881	0.9982	0.9958	1.0080	0.0	0.0	0.289	-4.95	37.2	0.993	0.998
337.	27	0.993	0.3880	0.9988	0.9963	1.0087	0.0	0.0	0.289	-4.95	37.2	0.993	0.998
347.	28	0.994	0.3885	0.9994	0.9974	1.0095	0.0	0.0	0.286	-5.01	37.2	0.994	0.999
357.	29	0.995	0.3887	0.9999	0.9978	1.0097	0.0	0.0	0.286	-5.03	37.2	0.995	0.999
7.	30	0.996	0.3891	1.0009	0.9990	1.0097	0.0	0.0	0.284	-5.07	37.3	0.996	0.999
17.	31	0.997	0.3895	1.0011	0.9995	1.0091	0.0	0.0	0.282	-5.11	37.3	0.997	0.999
27.	32	0.998	0.3905	1.0018	1.0006	1.0081	0.0	0.0	0.280	-5.16	37.4	0.998	1.000
37.	33	1.001	0.3917	1.0020	1.0015	1.0068	0.0	0.0	0.277	-5.24	37.4	1.001	1.000
47.	34	1.003	0.3929	1.0026	1.0027	1.0051	0.0	0.0	0.275	-5.37	37.5	1.003	1.001
57.	35	1.005	0.3941	1.0026	1.0033	1.0028	0.0	0.0	0.272	-5.38	37.6	1.005	1.001
67.	36	1.006	0.3950	1.0027	1.0039	1.0002	0.0	0.0	0.271	-5.41	37.6	1.006	1.001

APPENDIX B (Cont'd)

STATOR

FLOW SWIRL= 66.72DEG PARTICLE SWIRL=169.20DEG PSAVG= 57.40PSIA = 395736.PA
 PTAVG= 65.84PSIA = 453929.PA TTAVG=1099.7DFG R = 611.0DEG K VELAVG= 713.2FPS =217.4MPS
 RVELAVG= 794.9FPS = 242.3MPS AXVELAVG= 580.4FPS =176.9MPS U= 958.FPS = 292.MPS

THETA	SEG NO	VEL	MN	PS	PT	TT	WBL LBM/SEC	WBL KG/SEC	DF	INCIDENCE IN DEG	ALPHA IN DEG	AXIAL IN DEG	REL VEL
77.	1	1.003	0.4526	1.0008	1.0018	0.9982	0.0	0.0	0.329	-12.06	55.0	1.008	1.008
87.	2	1.002	0.4529	1.0006	1.0018	0.9960	0.0	0.0	0.329	-12.03	54.9	1.007	1.007
97.	3	1.002	0.4529	1.0009	1.0021	0.9945	0.0	0.0	0.330	-11.97	54.9	1.007	1.007
107.	4	1.001	0.4530	1.0009	1.0022	0.9937	0.0	0.0	0.331	-11.95	54.8	1.006	1.006
117.	5	1.002	0.4531	1.0005	1.0019	0.9934	0.0	0.0	0.331	-11.96	54.9	1.006	1.006
127.	6	1.001	0.4531	1.0005	1.0019	0.9933	0.0	0.0	0.331	-11.97	54.9	1.006	1.006
137.	7	1.001	0.4531	1.0005	1.0018	0.9934	0.0	0.0	0.331	-11.97	54.9	1.006	1.006
147.	8	1.002	0.4531	1.0000	1.0013	0.9934	0.0	0.0	0.330	-12.00	54.9	1.007	1.007
157.	9	1.001	0.4530	0.9997	1.0009	0.9934	0.0	0.0	0.331	-11.95	54.8	1.006	1.006
167.	10	1.001	0.4530	0.9993	1.0006	0.9932	0.0	0.0	0.331	-11.92	54.8	1.006	1.006
177.	11	1.001	0.4527	1.0009	1.0020	0.9933	0.0	0.0	0.333	-11.81	54.7	1.004	1.004
187.	12	1.001	0.4529	1.0003	1.0015	0.9927	0.0	0.0	0.333	-11.78	54.7	1.003	1.003
197.	13	1.000	0.4528	0.9999	1.0011	0.9923	0.0	0.0	0.334	-11.72	54.6	1.002	1.002
207.	14	1.000	0.4528	0.9987	0.9999	0.9920	0.0	0.0	0.335	-11.69	54.6	1.002	1.002
217.	15	0.999	0.4524	0.9987	0.9996	0.9924	0.0	0.0	0.336	-11.57	54.5	1.000	1.000
227.	16	0.998	0.4516	0.9996	1.0000	0.9935	0.0	0.0	0.339	-11.38	54.3	0.997	0.997
237.	17	0.998	0.4511	0.9990	0.9991	0.9950	0.0	0.0	0.341	-11.28	54.2	0.995	0.995
247.	18	0.998	0.4504	0.9988	0.9985	0.9971	0.0	0.0	0.341	-11.26	54.1	0.994	0.994
257.	19	0.998	0.4499	0.9989	0.9983	0.9955	0.0	0.0	0.342	-11.17	54.1	0.994	0.994
267.	20	0.998	0.4493	1.0000	0.9990	1.0019	0.0	0.0	0.342	-11.11	54.0	0.993	0.993
277.	21	0.998	0.4490	1.0002	0.9990	1.0038	0.0	0.0	0.343	-11.09	54.0	0.992	0.992
287.	22	0.998	0.4488	0.9998	0.9985	1.0050	0.0	0.0	0.342	-11.09	54.0	0.993	0.993
297.	23	0.998	0.4486	0.9996	0.9982	1.0060	0.0	0.0	0.343	-11.07	54.0	0.992	0.992
307.	24	0.998	0.4482	1.0003	0.9987	1.0069	0.0	0.0	0.344	-11.01	53.9	0.991	0.991
317.	25	0.998	0.4483	0.9995	0.9979	1.0074	0.0	0.0	0.343	-11.02	53.9	0.991	0.991
327.	26	0.998	0.4482	0.9990	0.9973	1.0080	0.0	0.0	0.343	-11.04	53.9	0.992	0.992
337.	27	0.998	0.4481	0.9995	0.9976	1.0087	0.0	0.0	0.343	-11.04	53.9	0.992	0.992
347.	28	0.999	0.4484	0.9994	0.9978	1.0092	0.0	0.0	0.341	-11.18	54.1	0.994	0.994
357.	29	0.999	0.4483	0.9998	0.9982	1.0096	0.0	0.0	0.340	-11.23	54.1	0.995	0.995
7.	30	0.999	0.4485	1.0006	0.9991	1.0097	0.0	0.0	0.339	-11.31	54.2	0.996	0.996
17.	31	1.000	0.4489	1.0003	0.9991	1.0091	0.0	0.0	0.337	-11.43	54.3	0.998	0.998
27.	32	1.001	0.4493	1.0009	0.9999	1.0083	0.0	0.0	0.336	-11.53	54.4	0.999	0.999
37.	33	1.002	0.4502	1.0003	0.9998	1.0069	0.0	0.0	0.333	-11.73	54.6	1.003	1.003
47.	34	1.002	0.4508	1.0008	1.0006	1.0054	0.0	0.0	0.331	-11.87	54.8	1.005	1.005
57.	35	1.003	0.4516	1.0005	1.0009	1.0032	0.0	0.0	0.329	-12.02	54.9	1.007	1.007
67.	36	1.003	0.4521	1.0010	1.0017	1.0008	0.0	0.0	0.329	-12.06	55.0	1.008	1.008

EXIT

FLOW SWIRL= 68.54DEG PARTICLE SWIRL=171.02DEG PSAVG= 62.32PSIA = 429675.PA
 PTAVG= 67.79PSIA = 467364.PA TTAVG=1099.7DFG R = 611.0DEG K VELAVG= 560.3FPS =170.8MPS
 RVELAVG= 0.0FPS = 0.0MPS AXVELAVG= 0.0FPS = 0.0MPS U= 958.FPS = 292.MPS

THETA	SEG NO	VEL	MN	PS	PT	TT	WBL LBM/SEC	WBL KG/SEC	DF	INCIDENCE IN DEG	ALPHA IN DEG	AXIAL IN DEG	REL VEL
79.	1	1.009	0.3552	1.0000	1.0016	0.9982	0.0	0.0	0.0	0.0	0.0	0.0	0.0
89.	2	1.008	0.3553	1.0000	1.0018	0.9960	0.0	0.0	0.0	0.0	0.0	0.0	0.0
99.	3	1.007	0.3551	1.0006	1.0022	0.9945	0.0	0.0	0.0	0.0	0.0	0.0	0.0
109.	4	1.006	0.3551	1.0008	1.0024	0.9937	0.0	0.0	0.0	0.0	0.0	0.0	0.0
119.	5	1.007	0.3552	1.0004	1.0021	0.9933	0.0	0.0	0.0	0.0	0.0	0.0	0.0
129.	6	1.007	0.3552	1.0004	1.0021	0.9933	0.0	0.0	0.0	0.0	0.0	0.0	0.0
139.	7	1.007	0.3552	1.0003	1.0020	0.9934	0.0	0.0	0.0	0.0	0.0	0.0	0.0
149.	8	1.007	0.3554	0.9997	1.0015	0.9934	0.0	0.0	0.0	0.0	0.0	0.0	0.0
159.	9	1.006	0.3551	0.9995	1.0012	0.9934	0.0	0.0	0.0	0.0	0.0	0.0	0.0
169.	10	1.006	0.3550	0.9992	1.0008	0.9932	0.0	0.0	0.0	0.0	0.0	0.0	0.0
179.	11	1.004	0.3543	1.0011	1.0023	0.9933	0.0	0.0	0.0	0.0	0.0	0.0	0.0
189.	12	1.003	0.3541	1.0006	1.0018	0.9927	0.0	0.0	0.0	0.0	0.0	0.0	0.0
199.	13	1.002	0.3538	1.0004	1.0014	0.9923	0.0	0.0	0.0	0.0	0.0	0.0	0.0
209.	14	1.001	0.3536	0.9993	1.0002	0.9920	0.0	0.0	0.0	0.0	0.0	0.0	0.0
219.	15	0.999	0.3528	0.9995	1.0000	0.9924	0.0	0.0	0.0	0.0	0.0	0.0	0.0
229.	16	0.998	0.3514	1.0006	1.0005	0.9935	0.0	0.0	0.0	0.0	0.0	0.0	0.0
239.	17	0.994	0.3506	1.0001	0.9996	0.9950	0.0	0.0	0.0	0.0	0.0	0.0	0.0
249.	18	0.993	0.3498	0.9998	0.9989	0.9971	0.0	0.0	0.0	0.0	0.0	0.0	0.0
259.	19	0.993	0.3492	0.9997	0.9986	0.9995	0.0	0.0	0.0	0.0	0.0	0.0	0.0
269.	20	0.992	0.3485	1.0007	0.9992	1.0019	0.0	0.0	0.0	0.0	0.0	0.0	0.0
279.	21	0.992	0.3461	1.0008	0.9991	1.0038	0.0	0.0	0.0	0.0	0.0	0.0	0.0
289.	22	0.992	0.3480	1.0002	0.9985	1.0050	0.0	0.0	0.0	0.0	0.0	0.0	0.0
299.	23	0.992	0.3478	1.0000	0.9981	1.0060	0.0	0.0	0.0	0.0	0.0	0.0	0.0
309.	24	0.991	0.3472	1.0007	0.9986	1.0069	0.0	0.0	0.0	0.0	0.0	0.0	0.0
319.	25	0.991	0.3472	0.9998	0.9977	1.0074	0.0	0.0	0.0	0.0	0.0	0.0	0.0
329.	26	0.991	0.3473	0.9992	0.9971	1.0080	0.0	0.0	0.0	0.0	0.0	0.0	0.0
339.	27	0.992	0.3472	0.9997	0.9976	1.0087	0.0	0.0	0.0	0.0	0.0	0.0	0.0
349.	28	0.994	0.3480	0.9993	0.9975	1.0092	0.0	0.0	0.0	0.0	0.0	0.0	0.0
359.	29	0.995	0.3483	0.9995	0.9979	1.0096	0.0	0.0	0.0	0.0	0.0	0.0	0.0
9.	30	0.996	0.3487	1.0002	0.9988	1.0097	0.0	0.0	0.0	0.0	0.0	0.0	0.0
19.	31	0.998	0.3496	0.9997	0.9987	1.0091	0.0	0.0	0.0	0.0	0.0	0.0	0.0
29.	32	1.000	0.3503	1.0002	0.9995	1.0083	0.0	0.0	0.0	0.0	0.0	0.0	0.0
39.	33	1.004	0.3518	0.9993	0.9993	1.0069	0.0	0.0	0.0	0.0	0.0	0.0	0.0
49.	34	1.006	0.3529	0.9996	1.0002	1.0054	0.0	0.0	0.0	0.0	0.0	0.0	0.0
59.	35	1.008	0.3542	0.9992	1.0004	1.0032	0.0	0.0	0.0	0.0	0.0	0.0	0.0
69.	36	1.009	0.3548	0.9999	1.0014	1.0008	0.0	0.0	0.0	0.0	0.0	0.0	0.0

APPENDIX B (Cont'd)

WICORR=217.3LBM/SEC = 98.6KG/SEC NICORR= 8644.RPM N2CORR=10216.RPM N2/W1(MECH)=1.309
 THETM=180.DEG BYPASS RATIO=1.253 MAX-MIN/AVG=0.132

FAN OD OUTPUT	CORR FLOW	PRESS RATIO	EFFICIENCY
FAN OD PERFORMANCE 2.6F/2	120.83 LBM/SEC 54.81 KG/SEC	1.750	0.763

--- ROW OUTPUT ---

IGV FLOW SWIRL= 0.0 DEG PARTICLE SWIRL= 0.0 DEG PSAVG= 6.36PSIA = 43859.PA
 PTAVG= 7.28PSIA = 50197.PA TTAVG= 532.6DEG R = 295.9DEG K VELA VG= 492.4FPS = 150.1MPS
 RVELAVG=1311.2FPS = 399.7MPS AXVELAVG= 488.7FPS = 149.0MPS U=1217.FPS = 371.MPS

THETA	SEG NO	VEL	MN	PS	PT	TT	WBL LBM/SEC	WBL KG/SEC	DF	INCIDENCE IN DEG	BETA IN DEG	AXIAL VEL	REL VEL
10.	1	0.993	0.4404	1.0457	1.0439	1.0000	0.0	0.0	-259	4.49	88.9	1.001	0.993
20.	2	0.994	0.4409	1.0454	1.0439	1.0000	0.0	0.0	-248	3.52	87.9	1.001	0.987
30.	3	0.996	0.4415	1.0451	1.0439	1.0000	0.0	0.0	-236	2.48	86.9	1.002	0.981
40.	4	0.998	0.4423	1.0445	1.0439	1.0000	0.0	0.0	-223	1.32	85.7	1.002	0.974
50.	5	1.000	0.4436	1.0438	1.0439	1.0000	0.0	0.0	-205	-0.05	84.3	1.003	0.966
60.	6	1.005	0.4456	1.0419	1.0432	1.0000	0.0	0.0	-182	-1.76	82.6	1.004	0.956
70.	7	1.012	0.4490	1.0380	1.0414	1.0000	0.0	0.0	-151	-3.99	80.4	1.005	0.942
80.	8	1.026	0.4554	1.0283	1.0354	1.0000	0.0	0.0	-103	-7.10	77.3	1.008	0.923
90.	9	1.035	0.4596	0.9878	0.9972	1.0000	0.0	0.0	-079	-8.53	75.9	1.011	0.914
100.	10	1.024	0.4547	0.9590	0.9652	1.0000	0.0	0.0	-115	-6.32	78.1	1.010	0.928
110.	11	1.011	0.4485	0.9579	0.9608	1.0000	0.0	0.0	-161	-3.31	81.1	1.006	0.946
120.	12	1.004	0.4451	0.9571	0.9581	1.0000	0.0	0.0	-189	-1.24	83.2	1.004	0.959
130.	13	0.999	0.4428	0.9577	0.9574	1.0000	0.0	0.0	-211	0.39	84.8	1.002	0.969
140.	14	0.995	0.4413	0.9579	0.9567	1.0000	0.0	0.0	-227	1.69	86.1	1.001	0.976
150.	15	0.993	0.4401	0.9578	0.9560	1.0000	0.0	0.0	-241	2.85	87.2	0.999	0.983
160.	16	0.991	0.4393	0.9583	0.9560	1.0000	0.0	0.0	-253	3.91	88.3	0.998	0.989
170.	17	0.990	0.4387	0.9586	0.9560	1.0000	0.0	0.0	-263	4.88	89.3	0.997	0.995
180.	18	0.989	0.4384	0.9588	0.9560	1.0000	0.0	0.0	-273	5.80	90.2	0.997	1.001
190.	19	0.989	0.4382	0.9589	0.9560	1.0000	0.0	0.0	-282	6.72	91.1	0.996	1.006
200.	20	0.989	0.4380	0.9589	0.9560	1.0000	0.0	0.0	-292	7.68	92.1	0.996	1.012
210.	21	0.989	0.4386	0.9587	0.9560	1.0000	0.0	0.0	-301	8.71	93.1	0.995	1.018
220.	22	0.991	0.4392	0.9584	0.9560	1.0000	0.0	0.0	-311	9.89	94.3	0.995	1.025
230.	23	0.993	0.4403	0.9580	0.9563	1.0000	0.0	0.0	-323	11.33	95.7	0.996	1.034
240.	24	0.997	0.4421	0.9588	0.9581	1.0000	0.0	0.0	-335	13.10	97.5	0.996	1.045
250.	25	1.003	0.4450	0.9625	0.9631	1.0000	0.0	0.0	-348	15.18	99.6	0.997	1.058
260.	26	1.012	0.4489	0.9716	0.9745	1.0000	0.0	0.0	-359	17.35	101.7	0.998	1.072
270.	27	1.017	0.4514	0.9927	0.9972	1.0000	0.0	0.0	-365	18.68	103.1	0.999	1.080
280.	28	1.012	0.4489	1.0239	1.0270	1.0000	0.0	0.0	-361	17.68	102.1	0.997	1.074
290.	29	1.003	0.4446	1.0366	1.0370	1.0000	0.0	0.0	-348	15.22	99.6	0.996	1.058
300.	30	0.997	0.4420	1.0423	1.0414	1.0000	0.0	0.0	-335	13.05	97.5	0.996	1.045
310.	31	0.994	0.4406	1.0450	1.0432	1.0000	0.0	0.0	-322	11.25	95.6	0.996	1.034
320.	32	0.992	0.4399	1.0460	1.0439	1.0000	0.0	0.0	-310	9.75	94.1	0.997	1.025
330.	33	0.992	0.4397	1.0462	1.0439	1.0000	0.0	0.0	-299	8.49	92.9	0.998	1.017
340.	34	0.992	0.4397	1.0462	1.0439	1.0000	0.0	0.0	-289	7.39	91.8	0.999	1.011
350.	35	0.992	0.4398	1.0461	1.0439	1.0000	0.0	0.0	-279	6.39	90.8	1.000	1.005
360.	36	0.993	0.4401	1.0459	1.0439	1.0000	0.0	0.0	-269	5.44	89.8	1.000	0.999

STAGE 1
ROTOR

FLOW SWIRL= 3.29DEG PARTICLE SWIRL= 3.29DEG PSAVG= 6.16PSIA = 42486.PA
 PTAVG= 7.21PSIA = 49714.PA TTAVG= 532.6DEG R = 295.9DEG K VELA VG= 530.1FPS = 161.8MPS
 RVELAVG=1180.2FPS = 359.7MPS AXVELAVG= 507.9FPS = 154.8MPS U=1217.FPS = 371.MPS

THETA	SEG NO	VEL	MN	PS	PT	TT	WBL LBM/SEC	WBL KG/SEC	DF	INCIDENCE IN DEG	BETA IN DEG	AXIAL VEL	REL VEL
13.	1	1.002	0.4801	1.0436	1.0444	1.0000	0.0	0.0	0.234	4.45	25.6	1.002	1.000
23.	2	1.003	0.4803	1.0435	1.0444	1.0000	0.0	0.0	0.234	4.44	25.6	1.003	1.000
33.	3	1.003	0.4805	1.0433	1.0444	1.0000	0.0	0.0	0.234	4.43	25.6	1.003	1.000
43.	4	1.003	0.4806	1.0432	1.0443	1.0000	0.0	0.0	0.234	4.42	25.6	1.003	1.000
53.	5	1.004	0.4807	1.0430	1.0442	1.0000	0.0	0.0	0.234	4.42	25.6	1.004	1.000
63.	6	1.004	0.4808	1.0421	1.0433	1.0000	0.0	0.0	0.234	4.41	25.6	1.004	1.000
73.	7	1.004	0.4809	1.0399	1.0412	1.0000	0.0	0.0	0.234	4.41	25.6	1.004	1.000
83.	8	1.004	0.4811	1.0333	1.0347	1.0000	0.0	0.0	0.234	4.40	25.6	1.004	1.000
93.	9	1.006	0.4819	0.9944	0.9963	1.0000	0.0	0.0	0.234	4.36	25.6	1.006	1.000
103.	10	1.007	0.4822	0.9629	0.9649	1.0000	0.0	0.0	0.235	4.34	25.7	1.007	1.000
113.	11	1.005	0.4816	0.9591	0.9608	1.0000	0.0	0.0	0.237	4.37	25.6	1.005	1.000
123.	12	1.004	0.4810	0.9570	0.9582	1.0000	0.0	0.0	0.240	4.40	25.6	1.004	1.000
133.	13	1.003	0.4804	0.9568	0.9576	1.0000	0.0	0.0	0.242	4.44	25.6	1.003	1.000
143.	14	1.002	0.4798	0.9565	0.9570	1.0000	0.0	0.0	0.244	4.47	25.5	1.002	1.000
153.	15	1.001	0.4793	0.9561	0.9563	1.0000	0.0	0.0	0.245	4.49	25.5	1.001	1.000
163.	16	1.000	0.4788	0.9564	0.9563	1.0000	0.0	0.0	0.246	4.52	25.5	1.000	1.000
173.	17	0.999	0.4784	0.9566	0.9563	1.0000	0.0	0.0	0.247	4.54	25.5	0.999	1.000
183.	18	0.998	0.4780	0.9568	0.9562	1.0000	0.0	0.0	0.248	4.55	25.4	0.998	1.000
193.	19	0.998	0.4778	0.9569	0.9562	1.0000	0.0	0.0	0.248	4.57	25.4	0.998	1.000
203.	20	0.997	0.4775	0.9570	0.9562	1.0000	0.0	0.0	0.249	4.58	25.4	0.997	1.000
213.	21	0.997	0.4773	0.9571	0.9561	1.0000	0.0	0.0	0.249	4.59	25.4	0.997	1.000
223.	22	0.997	0.4772	0.9571	0.9560	1.0000	0.0	0.0	0.249	4.60	25.4	0.997	1.000
233.	23	0.996	0.4771	0.9573	0.9562	1.0000	0.0	0.0	0.249	4.60	25.4	0.996	1.000
243.	24	0.996	0.4769	0.9590	0.9578	1.0000	0.0	0.0	0.249	4.61	25.4	0.996	1.000
253.	25	0.996	0.4768	0.9642	0.9628	1.0000	0.0	0.0	0.249	4.62	25.4	0.996	1.000
263.	26	0.995	0.4765	0.9753	0.9738	1.0000	0.0	0.0	0.249	4.63	25.4	0.995	1.000
273.	27	0.994	0.4761	0.9978	0.9960	1.0000	0.0	0.0	0.249	4.65	25.3	0.994	1.000
283.	28	0.994	0.4758	1.0281	1.0260	1.0000	0.0	0.0	0.247	4.67	25.3	0.994	1.000
293.	29	0.995	0.4763	1.0384	1.0366	1.0000	0.0	0.0	0.245	4.64	25.4	0.995	1.000
303.	30	0.996	0.4769	1.0425	1.0411	1.0000	0.0	0.0	0.242	4.61	25.4	0.996	1.000
313.	31	0.997	0.4775	1.0441	1.0432	1.0000	0.0	0.0	0.240	4.58	25.4	0.997	1.000
323.	32	0.998	0.4781	1.0446	1.0440	1.0000	0.0	0.0	0.238	4.55	25.4	0.998	1.000
333.	33	0.999	0.4787	1.0444	1.0442	1.0000	0.0	0.0	0.237	4.52	25.5	0.999	1.000
343.	34	1.000	0.4791	1.0441	1.0443	1.0000	0.0	0.0	0.236	4.50	25.5	1.000	1.000
353.	35	1.001	0.4795	1.0439	1.0443	1.0000	0.0	0.0	0.235	4.48	25.5	1.001	1.000
3.	36	1.002	0.4798	1.0438	1.0444	1.0000	0.0	0.0	0.235	4.46	25.5	1.002	1.000

APPENDIX B (Cont'd)

STATOR

FLOW SWIRL= 1.74DEG PARTICLE SWIRL= 11.48DEG PSAVEG= 7.89PSIA = 54406.PA
 PTAVG= 9.37PSIA = 64597.PA TTAVG= 587.6DEG R = 326.5DEG K VELAVG= 581.5FPS =177.2MPS
 RVELAVG= 991.8FPS = 302.3MPS AXVELAVG= 490.1FPS =149.4MPS U=1175.FPS = 358.MPS

THETA	SEG NO	VEL	MN	PS	PT	TT	WBL LBM/SEC	WBL KG/SEC	DF	INCIDENCE IN DEG	ALPHA IN DEG	AXIAL VEL	REL VEL
12.	1	1.002	0.5027	1.0384	1.0393	0.9985	0.0	0.0	0.187	-11.62	58.0	1.006	1.006
22.	2	1.001	0.5025	1.0383	1.0391	0.9983	0.0	0.0	0.186	-11.64	58.0	1.006	1.006
32.	3	1.001	0.5023	1.0382	1.0389	0.9982	0.0	0.0	0.186	-11.66	58.1	1.006	1.006
42.	4	1.001	0.5022	1.0382	1.0387	0.9981	0.0	0.0	0.185	-11.67	58.1	1.006	1.006
52.	5	1.000	0.5021	1.0380	1.0385	0.9980	0.0	0.0	0.185	-11.68	58.1	1.006	1.006
62.	6	1.000	0.5020	1.0370	1.0374	0.9977	0.0	0.0	0.185	-11.68	58.1	1.007	1.007
72.	7	1.000	0.5020	1.0346	1.0350	0.9973	0.0	0.0	0.185	-11.68	58.1	1.007	1.007
82.	8	0.999	0.5020	1.0272	1.0276	0.9960	0.0	0.0	0.185	-11.68	58.1	1.006	1.006
92.	9	0.996	0.5028	0.9811	0.9820	0.9867	0.0	0.0	0.186	-11.64	58.0	1.006	1.006
102.	10	0.994	0.5015	0.9531	0.9532	0.9883	0.0	0.0	0.188	-11.56	58.0	1.005	1.005
112.	11	0.994	0.4993	0.9584	0.9570	0.9966	0.0	0.0	0.191	-11.38	57.8	1.003	1.003
122.	12	0.994	0.4988	0.9584	0.9568	0.9978	0.0	0.0	0.196	-11.15	57.5	1.001	1.001
132.	13	0.994	0.4987	0.9599	0.9582	0.9990	0.0	0.0	0.200	-10.97	57.4	0.999	0.999
142.	14	0.995	0.4988	0.9604	0.9587	0.9995	0.0	0.0	0.203	-10.82	57.2	0.998	0.998
152.	15	0.995	0.4990	0.9606	0.9590	1.0000	0.0	0.0	0.205	-10.71	57.1	0.997	0.997
162.	16	0.996	0.4992	0.9613	0.9599	1.0006	0.0	0.0	0.207	-10.63	57.0	0.996	0.996
172.	17	0.997	0.4995	0.9617	0.9604	1.0010	0.0	0.0	0.208	-10.56	57.0	0.995	0.995
182.	18	0.997	0.4997	0.9619	0.9608	1.0012	0.0	0.0	0.210	-10.51	56.9	0.994	0.994
192.	19	0.998	0.4999	0.9621	0.9611	1.0015	0.0	0.0	0.210	-10.47	56.9	0.994	0.994
202.	20	0.998	0.5001	0.9622	0.9613	1.0017	0.0	0.0	0.211	-10.44	56.8	0.994	0.994
212.	21	0.999	0.5003	0.9622	0.9615	1.0018	0.0	0.0	0.211	-10.42	56.8	0.994	0.994
222.	22	0.999	0.5005	0.9622	0.9616	1.0019	0.0	0.0	0.212	-10.40	56.8	0.993	0.993
232.	23	1.000	0.5006	0.9624	0.9619	1.0021	0.0	0.0	0.212	-10.39	56.8	0.993	0.993
242.	24	1.000	0.5006	0.9644	0.9639	1.0026	0.0	0.0	0.212	-10.38	56.8	0.993	0.993
252.	25	1.000	0.5007	0.9704	0.9698	1.0038	0.0	0.0	0.212	-10.38	56.8	0.993	0.993
262.	26	1.002	0.5007	0.9827	0.9822	1.0056	0.0	0.0	0.211	-10.40	56.8	0.993	0.993
272.	27	1.003	0.5008	1.0074	1.0070	1.0091	0.0	0.0	0.211	-10.45	56.9	0.994	0.994
282.	28	1.006	0.5015	1.0380	1.0380	1.0111	0.0	0.0	0.208	-10.58	57.0	0.995	0.995
292.	29	1.006	0.5033	1.0409	1.0421	1.0050	0.0	0.0	0.206	-10.75	57.2	0.997	0.997
302.	30	1.006	0.5040	1.0414	1.0431	1.0027	0.0	0.0	0.200	-10.97	57.4	0.999	0.999
312.	31	1.006	0.5041	1.0410	1.0429	1.0013	0.0	0.0	0.196	-11.15	57.6	1.001	1.001
322.	32	1.005	0.5040	1.0403	1.0422	1.0004	0.0	0.0	0.193	-11.29	57.7	1.003	1.003
332.	33	1.005	0.5038	1.0394	1.0411	0.9997	0.0	0.0	0.191	-11.40	57.8	1.004	1.004
342.	34	1.004	0.5035	1.0390	1.0404	0.9993	0.0	0.0	0.189	-11.48	57.9	1.004	1.004
352.	35	1.003	0.5032	1.0387	1.0399	0.9990	0.0	0.0	0.188	-11.54	57.9	1.005	1.005
2.	36	1.002	0.5030	1.0385	1.0396	0.9987	0.0	0.0	0.187	-11.59	58.0	1.006	1.006

STAGE 2 ROTOR

FLOW SWIRL= 6.08DEG PARTICLE SWIRL= 15.82DEG PSAVEG= 8.16PSIA = 56249.PA
 PTAVG= 9.45PSIA = 65160.PA TTAVG= 587.6DEG R = 326.5DEG K VELAVG= 599.1FPS =184.3MPS
 RVELAVG=1107.1FPS = 337.4MPS AXVELAVG= 512.2FPS =156.1MPS U=1150.FPS = 350.MPS

THETA	SEG NO	VEL	MN	PS	PT	TT	WBL LBM/SEC	WBL KG/SEC	DF	INCIDENCE IN DEG	BETA IN DEG	AXIAL VEL	REL VEL
16.	1	1.007	0.4667	1.0374	1.0396	0.9985	0.0	0.0	0.168	0.26	27.7	1.007	1.001
26.	2	1.007	0.4669	1.0372	1.0396	0.9983	0.0	0.0	0.168	0.25	27.7	1.007	1.001
36.	3	1.007	0.4670	1.0371	1.0395	0.9982	0.0	0.0	0.168	0.24	27.8	1.007	1.001
46.	4	1.007	0.4671	1.0370	1.0395	0.9981	0.0	0.0	0.168	0.24	27.8	1.007	1.001
56.	5	1.007	0.4672	1.0368	1.0394	0.9980	0.0	0.0	0.168	0.24	27.8	1.007	1.001
66.	6	1.007	0.4673	1.0357	1.0384	0.9977	0.0	0.0	0.168	0.24	27.8	1.007	1.001
76.	7	1.007	0.4674	1.0333	1.0360	0.9973	0.0	0.0	0.169	0.24	27.8	1.007	1.001
86.	8	1.007	0.4677	1.0259	1.0287	0.9960	0.0	0.0	0.170	0.24	27.8	1.007	1.001
96.	9	1.007	0.4697	0.9797	0.9837	0.9867	0.0	0.0	0.177	0.25	27.8	1.007	1.001
106.	10	1.006	0.4689	0.9519	0.9553	0.9883	0.0	0.0	0.185	0.28	27.7	1.006	1.000
116.	11	1.004	0.4658	0.9575	0.9590	0.9966	0.0	0.0	0.188	0.33	27.7	1.004	1.000
126.	12	1.001	0.4643	0.9579	0.9586	0.9978	0.0	0.0	0.190	0.41	27.6	1.001	1.000
136.	13	0.999	0.4630	0.9598	0.9596	0.9990	0.0	0.0	0.192	0.46	27.5	0.999	1.000
146.	14	0.997	0.4620	0.9606	0.9599	0.9995	0.0	0.0	0.193	0.51	27.5	0.997	1.000
156.	15	0.996	0.4613	0.9610	0.9598	1.0000	0.0	0.0	0.194	0.55	27.5	0.996	1.000
166.	16	0.995	0.4607	0.9619	0.9604	1.0006	0.0	0.0	0.195	0.57	27.4	0.995	1.000
176.	17	0.994	0.4602	0.9625	0.9606	1.0010	0.0	0.0	0.195	0.59	27.4	0.994	1.000
186.	18	0.994	0.4599	0.9628	0.9608	1.0012	0.0	0.0	0.196	0.61	27.4	0.994	1.000
196.	19	0.993	0.4596	0.9631	0.9609	1.0015	0.0	0.0	0.196	0.62	27.4	0.993	0.999
206.	20	0.993	0.4594	0.9632	0.9609	1.0017	0.0	0.0	0.196	0.63	27.4	0.993	0.999
216.	21	0.993	0.4592	0.9634	0.9609	1.0018	0.0	0.0	0.197	0.64	27.4	0.993	0.999
226.	22	0.992	0.4591	0.9634	0.9609	1.0019	0.0	0.0	0.197	0.65	27.4	0.992	0.999
236.	23	0.992	0.4590	0.9637	0.9611	1.0021	0.0	0.0	0.197	0.65	27.3	0.992	0.999
246.	24	0.992	0.4588	0.9657	0.9630	1.0026	0.0	0.0	0.196	0.65	27.3	0.992	0.999
256.	25	0.992	0.4585	0.9717	0.9688	1.0038	0.0	0.0	0.193	0.65	27.4	0.992	0.999
266.	26	0.992	0.4582	0.9840	0.9809	1.0056	0.0	0.0	0.188	0.63	27.4	0.993	0.999
276.	27	0.993	0.4577	1.0088	1.0053	1.0091	0.0	0.0	0.180	0.59	27.4	0.995	1.000
286.	28	0.995	0.4579	1.0393	1.0359	1.0111	0.0	0.0	0.175	0.53	27.5	0.997	1.000
296.	29	0.997	0.4603	1.0418	1.0399	1.0050	0.0	0.0	0.173	0.47	27.5	0.999	1.000
306.	30	0.999	0.4621	1.0419	1.0412	1.0027	0.0	0.0	0.171	0.41	27.6	1.001	1.000
316.	31	1.001	0.4634	1.0412	1.0413	1.0013	0.0	0.0	0.170	0.36	27.6	1.003	1.000
326.	32	1.003	0.4644	1.0402	1.0409	1.0004	0.0	0.0	0.169	0.33	27.7	1.004	1.000
336.	33	1.004	0.4652	1.0390	1.0403	0.9997	0.0	0.0	0.169	0.30	27.7	1.005	1.000
346.	34	1.005	0.4658	1.0383	1.0400	0.9993	0.0	0.0	0.169	0.28	27.7	1.006	1.000
356.	35	1.006	0.4662	1.0379	1.0398	0.9990	0.0	0.0	0.168	0.27	27.7	1.006	1.000
6.	36	1.006	0.4665	1.0376	1.0397	0.9987	0.0	0.0	0.168	0.27	27.7	1.006	1.000

APPENDIX B (Cont'd)

STATOR

FLOW SWIRL= 4.19DEG PARTICLE SWIRL= 20.57DEG PSAVG= 9.78PSIA = 67464.PA
 PTAVG= 11.38PSIA = 78485.PA TTAGV= 626.1DEG R = 347.8DEG K VELAUG= 564.3FPS =172.0MPS
 RVELAVG= 972.7FPS = 296.5MPS AXVELAVG= 487.3FPS =148.5MPS U=1126.FPS = 343.MPS

THETA	SEG	NO	VEL	MN	PS	PT	TT	WBL LBM/SEC	WBL KG/SEC	DF	INCIDENCE IN DEG	BETA IN DEG	AXIAL VEL	REL VEL
14.	1	1.001	0.4714	1.0318	1.0326	0.9972	0.0	0.0	0.0	0.214	-19.32	60.8	1.011	1.011
24.	2	1.001	0.4713	1.0317	1.0324	0.9969	0.0	0.0	0.0	0.213	-19.34	60.8	1.011	1.011
34.	3	1.001	0.4712	1.0318	1.0325	0.9968	0.0	0.0	0.0	0.213	-19.34	60.8	1.011	1.011
44.	4	1.000	0.4712	1.0318	1.0324	0.9967	0.0	0.0	0.0	0.213	-19.34	60.8	1.011	1.011
54.	5	1.000	0.4712	1.0317	1.0323	0.9965	0.0	0.0	0.0	0.213	-19.34	60.8	1.011	1.011
64.	6	1.000	0.4711	1.0309	1.0315	0.9963	0.0	0.0	0.0	0.214	-19.32	60.8	1.011	1.011
74.	7	1.000	0.4712	1.0287	1.0293	0.9957	0.0	0.0	0.0	0.214	-19.30	60.8	1.011	1.011
84.	8	0.999	0.4712	1.0220	1.0227	0.9943	0.0	0.0	0.0	0.216	-19.21	60.7	1.010	1.010
94.	9	0.997	0.4724	0.9807	0.9821	0.9844	0.0	0.0	0.0	0.226	-18.66	60.2	1.004	1.004
104.	10	0.992	0.4703	0.9546	0.9547	0.9823	0.0	0.0	0.0	0.239	-18.03	59.5	0.998	0.998
114.	11	0.990	0.4672	0.9623	0.9605	0.9923	0.0	0.0	0.0	0.246	-17.79	59.3	0.995	0.995
124.	12	0.992	0.4669	0.9661	0.9641	0.9978	0.0	0.0	0.0	0.250	-17.61	59.1	0.994	0.994
134.	13	0.994	0.4672	0.9677	0.9658	0.9994	0.0	0.0	0.0	0.254	-17.45	59.0	0.992	0.992
144.	14	0.995	0.4676	0.9682	0.9666	1.0004	0.0	0.0	0.0	0.256	-17.35	58.8	0.991	0.991
154.	15	0.996	0.4680	0.9681	0.9667	1.0010	0.0	0.0	0.0	0.258	-17.27	58.8	0.990	0.990
164.	16	0.997	0.4683	0.9686	0.9674	1.0017	0.0	0.0	0.0	0.259	-17.21	58.7	0.990	0.990
174.	17	0.998	0.4685	0.9689	0.9678	1.0022	0.0	0.0	0.0	0.260	-17.17	58.7	0.989	0.989
184.	18	0.998	0.4687	0.9690	0.9681	1.0026	0.0	0.0	0.0	0.261	-17.14	58.6	0.989	0.989
194.	19	0.999	0.4688	0.9691	0.9682	1.0028	0.0	0.0	0.0	0.262	-17.11	58.6	0.989	0.989
204.	20	0.999	0.4690	0.9690	0.9683	1.0031	0.0	0.0	0.0	0.262	-17.10	58.6	0.988	0.988
214.	21	0.999	0.4690	0.9691	0.9684	1.0033	0.0	0.0	0.0	0.262	-17.08	58.6	0.988	0.988
224.	22	0.999	0.4691	0.9690	0.9683	1.0034	0.0	0.0	0.0	0.263	-17.07	58.6	0.988	0.988
234.	23	1.000	0.4691	0.9691	0.9685	1.0036	0.0	0.0	0.0	0.263	-17.07	58.6	0.988	0.988
244.	24	1.000	0.4691	0.9709	0.9702	1.0041	0.0	0.0	0.0	0.262	-17.09	58.6	0.988	0.988
254.	25	1.000	0.4690	0.9763	0.9756	1.0055	0.0	0.0	0.0	0.261	-17.17	58.7	0.989	0.989
264.	26	1.002	0.4691	0.9872	0.9865	1.0078	0.0	0.0	0.0	0.257	-17.36	58.3	0.995	0.995
274.	27	1.004	0.4692	1.0089	1.0083	1.0118	0.0	0.0	0.0	0.248	-17.78	58.9	1.002	1.002
284.	28	1.007	0.4701	1.0354	1.0353	1.0150	0.0	0.0	0.0	0.236	-18.39	59.9	1.002	1.002
294.	29	1.009	0.4725	1.0365	1.0380	1.0092	0.0	0.0	0.0	0.227	-18.76	60.3	1.005	1.005
304.	30	1.008	0.4733	1.0336	1.0357	1.0035	0.0	0.0	0.0	0.222	-18.96	60.5	1.007	1.007
314.	31	1.007	0.4731	1.0327	1.0346	1.0010	0.0	0.0	0.0	0.219	-19.10	60.6	1.009	1.009
324.	32	1.005	0.4727	1.0323	1.0339	0.9997	0.0	0.0	0.0	0.217	-19.18	60.7	1.010	1.010
334.	33	1.004	0.4723	1.0317	1.0331	0.9987	0.0	0.0	0.0	0.216	-19.24	60.7	1.010	1.010
344.	34	1.003	0.4720	1.0316	1.0327	0.9981	0.0	0.0	0.0	0.215	-19.27	60.8	1.011	1.011
354.	35	1.002	0.4717	1.0315	1.0325	0.9977	0.0	0.0	0.0	0.214	-19.30	60.8	1.011	1.011
4.	36	1.002	0.4715	1.0316	1.0325	0.9974	0.0	0.0	0.0	0.214	-19.32	60.8	1.011	1.011

STAGE 3 ROTOR

FLOW SWIRL= 7.58DEG PARTICLE SWIRL= 23.96DEG PSAVG= 9.74PSIA = 67131.PA
 PTAVG= 11.11PSIA = 76619.PA TTAGV= 626.1DEG R = 347.8DEG K VELAUG= 528.0FPS =160.9MPS
 RVELAVG=1144.1FPS = 348.7MPS AXVELAVG= 521.0FPS =158.8MPS U=1104.FPS = 337.MPS

THETA	SEG	NO	VEL	MN	PS	PT	TT	WBL LBM/SEC	WBL KG/SEC	DF	INCIDENCE IN DEG	BETA IN DEG	AXIAL VEL	REL VEL
10.	1	1.015	0.4463	1.0268	1.0313	0.9972	0.0	0.0	0.0	0.215	-2.07	27.5	1.015	1.002
20.	2	1.015	0.4465	1.0266	1.0312	0.9969	0.0	0.0	0.0	0.214	-2.08	27.5	1.015	1.002
30.	3	1.016	0.4465	1.0266	1.0312	0.9968	0.0	0.0	0.0	0.215	-2.08	27.5	1.016	1.002
40.	4	1.016	0.4466	1.0265	1.0312	0.9967	0.0	0.0	0.0	0.215	-2.08	27.5	1.016	1.002
50.	5	1.016	0.4467	1.0264	1.0311	0.9965	0.0	0.0	0.0	0.216	-2.08	27.5	1.015	1.002
60.	6	1.015	0.4466	1.0256	1.0303	0.9963	0.0	0.0	0.0	0.216	-2.07	27.5	1.015	1.002
70.	7	1.014	0.4464	1.0170	1.0216	0.9943	0.0	0.0	0.0	0.223	-2.04	27.4	1.014	1.002
80.	8	1.014	0.4464	1.0170	1.0216	0.9943	0.0	0.0	0.0	0.223	-2.04	27.4	1.014	1.002
90.	9	1.008	0.4459	0.9766	0.9807	0.9844	0.0	0.0	0.0	0.258	-1.89	27.3	1.008	1.001
100.	10	1.000	0.4426	0.9526	0.9547	0.9823	0.0	0.0	0.0	0.284	-1.68	27.1	1.000	1.000
110.	11	0.995	0.4381	0.9626	0.9622	0.9923	0.0	0.0	0.0	0.281	-1.56	27.0	0.995	0.999
120.	12	0.992	0.4354	0.9680	0.9661	0.9978	0.0	0.0	0.0	0.276	-1.48	26.9	0.992	0.999
130.	13	0.989	0.4340	0.9706	0.9678	0.9994	0.0	0.0	0.0	0.274	-1.36	26.8	0.988	0.998
140.	14	0.988	0.4331	0.9718	0.9684	1.0004	0.0	0.0	0.0	0.273	-1.35	26.8	0.987	0.998
150.	15	0.987	0.4324	0.9722	0.9684	1.0010	0.0	0.0	0.0	0.273	-1.33	26.7	0.986	0.998
160.	16	0.986	0.4318	0.9731	0.9690	1.0017	0.0	0.0	0.0	0.273	-1.31	26.7	0.985	0.998
170.	17	0.985	0.4314	0.9737	0.9694	1.0022	0.0	0.0	0.0	0.273	-1.30	26.7	0.985	0.998
180.	18	0.985	0.4311	0.9740	0.9696	1.0026	0.0	0.0	0.0	0.273	-1.29	26.7	0.984	0.998
190.	19	0.984	0.4309	0.9742	0.9696	1.0028	0.0	0.0	0.0	0.273	-1.29	26.7	0.984	0.998
200.	20	0.984	0.4307	0.9743	0.9697	1.0031	0.0	0.0	0.0	0.273	-1.28	26.7	0.984	0.998
210.	21	0.984	0.4306	0.9745	0.9697	1.0033	0.0	0.0	0.0	0.273	-1.27	26.7	0.984	0.998
220.	22	0.984	0.4305	0.9745	0.9696	1.0036	0.0	0.0	0.0	0.272	-1.27	26.7	0.983	0.998
230.	23	0.983	0.4304	0.9746	0.9698	1.0041	0.0	0.0	0.0	0.271	-1.28	26.7	0.984	0.998
240.	24	0.984	0.4304	0.9764	0.9715	1.0055	0.0	0.0	0.0	0.267	-1.30	26.7	0.985	0.998
250.	25	0.985	0.4305	0.9816	0.9768	1.0078	0.0	0.0	0.0	0.256	-1.37	26.8	0.987	0.998
260.	26	0.987	0.4312	0.9920	0.9875	1.0078	0.0	0.0	0.0	0.237	-1.50	26.9	0.992	0.999
270.	27	0.992	0.4327	1.0125	1.0088	1.0118	0.0	0.0	0.0	0.212	-1.70	27.1	1.000	1.000
280.	28	1.000	0.4356	1.0370	1.0349	1.0150	0.0	0.0	0.0	0.209	-1.84	27.2	1.006	1.001
290.	29	1.006	0.4393	1.0362	1.0364	1.0092	0.0	0.0	0.0	0.209	-1.84	27.2	1.006	1.001
300.	30	1.009	0.4421	1.0317	1.0337	1.0035	0.0	0.0	0.0	0.211	-1.92	27.3	1.009	1.001
310.	31	1.011	0.4437	1.0297	1.0327	1.0010	0.0	0.0	0.0	0.214	-1.98	27.4	1.011	1.002
320.	32	1.013	0.4446	1.0286	1.0321	0.9997	0.0	0.0	0.0	0.215	-2.01	27.4	1.013	1.002
330.	33	1.014	0.4453	1.0275	1.0314	0.9987	0.0	0.0	0.0	0.215	-2.04	27.4	1.014	1.002
340.	34	1.014	0.4457	1.0271	1.0312	0.9981	0.0	0.0	0.0	0.215	-2.05	27.5	1.014	1.002
350.	35	1.015	0.4460	1.0268	1.0311	0.9977	0.0	0.0	0.0	0.215	-2.06	27.5	1.015	1.002
4.	36	1.015	0.4462	1.0267	1.0312	0.9974	0.0	0.0	0.0	0.215	-2.07	27.5	1.015	1.002

APPENDIX B (Cont'd)

STATOR													
FLOW SWIRL= 15.33DEG			PARTICLE SWIRL= 30.52DEG				PSAVG= 11.73PSIA = 80844.PA						
PTAVG= 13.36PSIA = 92126.PA			TTAVG= 653.8DEG R = 363.2DEG K				VELAVG= 536.6FPS = 163.6MPS						
RVELAVG= 950.6FPS = 289.7MPS			AXVELAVG= 453.8FPS = 138.3MPS				U=1121.FPS = 342.MPS						
THETA	SEG NO	VEL	MN	PS	PT	TT	WBL LBM/SEC	WBL KG/SEC	DF	INCIDENCE IN DEG	ALPHA IN DEG	AXIAL VEL	REL VEL
25.	1	0.998	0.4379	1.0091	1.0100	0.9894	0.0	0.0	0.266	-6.40	60.4	1.025	1.025
35.	2	0.998	0.4381	1.0082	1.0092	0.9890	0.0	0.0	0.264	-6.48	60.5	1.026	1.026
45.	3	0.998	0.4378	1.0089	1.0097	0.9889	0.0	0.0	0.265	-6.43	60.4	1.026	1.026
55.	4	0.998	0.4378	1.0089	1.0097	0.9887	0.0	0.0	0.265	-6.43	60.4	1.026	1.026
65.	5	0.998	0.4379	1.0085	1.0094	0.9886	0.0	0.0	0.265	-6.45	60.5	1.026	1.026
75.	6	0.997	0.4375	1.0092	1.0099	0.9885	0.0	0.0	0.267	-6.31	60.3	1.024	1.024
85.	7	0.997	0.4374	1.0081	1.0087	0.9882	0.0	0.0	0.269	-6.21	60.2	1.023	1.023
95.	8	0.994	0.4365	1.0067	1.0068	0.9878	0.0	0.0	0.278	-5.71	59.7	1.019	1.019
105.	9	0.981	0.4309	0.9983	0.9951	0.9847	0.0	0.0	0.332	-2.63	56.6	0.988	0.988
115.	10	0.973	0.4274	0.9921	0.9869	0.9860	0.0	0.0	0.374	-0.36	54.4	0.966	0.966
125.	11	0.982	0.4295	0.9917	0.9878	0.9935	0.0	0.0	0.370	-0.62	54.6	0.968	0.968
135.	12	0.989	0.4312	0.9921	0.9891	1.0012	0.0	0.0	0.364	-0.97	55.0	0.972	0.972
145.	13	0.994	0.4326	0.9924	0.9902	1.0056	0.0	0.0	0.360	-1.20	55.2	0.974	0.974
155.	14	0.997	0.4333	0.9922	0.9904	1.0072	0.0	0.0	0.359	-1.23	55.2	0.974	0.974
165.	15	0.999	0.4339	0.9917	0.9902	1.0083	0.0	0.0	0.359	-1.24	55.2	0.974	0.974
175.	16	1.000	0.4342	0.9917	0.9904	1.0093	0.0	0.0	0.359	-1.25	55.2	0.975	0.975
185.	17	1.001	0.4344	0.9918	0.9906	1.0100	0.0	0.0	0.359	-1.25	55.3	0.975	0.975
195.	18	1.001	0.4345	0.9918	0.9907	1.0106	0.0	0.0	0.359	-1.25	55.2	0.975	0.975
205.	19	1.002	0.4347	0.9918	0.9907	1.0110	0.0	0.0	0.359	-1.25	55.2	0.975	0.975
215.	20	1.002	0.4348	0.9916	0.9906	1.0113	0.0	0.0	0.359	-1.26	55.3	0.975	0.975
225.	21	1.002	0.4347	0.9919	0.9909	1.0117	0.0	0.0	0.360	-1.22	55.2	0.974	0.974
235.	22	1.003	0.4349	0.9915	0.9906	1.0118	0.0	0.0	0.359	-1.25	55.2	0.975	0.975
245.	23	1.003	0.4350	0.9912	0.9903	1.0119	0.0	0.0	0.359	-1.29	55.3	0.975	0.975
255.	24	1.003	0.4352	0.9917	0.9909	1.0122	0.0	0.0	0.356	-1.40	55.4	0.976	0.976
265.	25	1.005	0.4359	0.9931	0.9927	1.0127	0.0	0.0	0.350	-1.78	55.8	0.980	0.980
275.	26	1.009	0.4375	0.9950	0.9957	1.0130	0.0	0.0	0.334	-2.67	56.7	0.989	0.989
285.	27	1.016	0.4408	0.9992	1.0018	1.0130	0.0	0.0	0.303	-4.40	58.4	1.006	1.006
295.	28	1.024	0.4447	1.0047	1.0097	1.0115	0.0	0.0	0.265	-6.60	60.6	1.027	1.027
305.	29	1.019	0.4436	1.0069	1.0117	1.0059	0.0	0.0	0.258	-6.92	60.9	1.030	1.030
315.	30	1.012	0.4418	1.0078	1.0110	0.9994	0.0	0.0	0.261	-6.71	60.7	1.028	1.028
325.	31	1.006	0.4403	1.0081	1.0104	0.9949	0.0	0.0	0.264	-6.54	60.5	1.027	1.027
335.	32	1.003	0.4392	1.0088	1.0105	0.9928	0.0	0.0	0.264	-6.43	60.4	1.026	1.026
345.	33	1.001	0.4388	1.0081	1.0096	0.9914	0.0	0.0	0.265	-6.45	60.5	1.026	1.026
355.	34	1.000	0.4383	1.0086	1.0097	0.9906	0.0	0.0	0.264	-6.42	60.4	1.026	1.026
5.	35	0.999	0.4383	1.0080	1.0092	0.9899	0.0	0.0	0.265	-6.47	60.5	1.026	1.026
15.	36	0.998	0.4380	1.0087	1.0097	0.9896	0.0	0.0	0.265	-6.42	60.4	1.026	1.026

EXIT													
FLOW SWIRL= 17.88DEG			PARTICLE SWIRL= 41.07DEG				PSAVG= 11.47PSIA = 79106.PA						
PTAVG= 12.74PSIA = 87845.PA			TTAVG= 653.8DEG R = 363.2DEG K				VELAVG= 481.0FPS = 146.6MPS						
RVELAVG= 0.0FPS = 0.0MPS			AXVELAVG= 0.0FPS = 0.0MPS				U=1121.FPS = 342.MPS						
THETA	SEG NO	VEL	MN	PS	PT	TT	WBL LBM/SEC	WBL KG/SEC	DF	INCIDENCE IN DEG	ALPHA IN DEG	AXIAL VEL	REL VEL
28.	1	1.033	0.4051	1.0004	1.0085	0.9894	0.0	0.0	0.0	0.0	0.0	0.0	0.0
38.	2	1.034	0.4056	0.9992	1.0076	0.9890	0.0	0.0	0.0	0.0	0.0	0.0	0.0
48.	3	1.033	0.4054	1.0000	1.0082	0.9889	0.0	0.0	0.0	0.0	0.0	0.0	0.0
58.	4	1.033	0.4054	0.9999	1.0082	0.9887	0.0	0.0	0.0	0.0	0.0	0.0	0.0
68.	5	1.034	0.4056	0.9995	1.0079	0.9886	0.0	0.0	0.0	0.0	0.0	0.0	0.0
78.	6	1.032	0.4048	1.0008	1.0087	0.9885	0.0	0.0	0.0	0.0	0.0	0.0	0.0
88.	7	1.030	0.4043	1.0000	1.0077	0.9882	0.0	0.0	0.0	0.0	0.0	0.0	0.0
98.	8	1.024	0.4018	1.0001	1.0064	0.9878	0.0	0.0	0.0	0.0	0.0	0.0	0.0
108.	9	0.987	0.3874	0.9996	0.9982	0.9847	0.0	0.0	0.0	0.0	0.0	0.0	0.0
118.	10	0.958	0.3757	1.0001	0.9926	0.9860	0.0	0.0	0.0	0.0	0.0	0.0	0.0
128.	11	0.961	0.3753	0.9998	0.9922	0.9935	0.0	0.0	0.0	0.0	0.0	0.0	0.0
138.	12	0.965	0.3754	1.0001	0.9925	1.0012	0.0	0.0	0.0	0.0	0.0	0.0	0.0
148.	13	0.967	0.3755	1.0003	0.9927	1.0056	0.0	0.0	0.0	0.0	0.0	0.0	0.0
158.	14	0.967	0.3753	1.0002	0.9925	1.0072	0.0	0.0	0.0	0.0	0.0	0.0	0.0
168.	15	0.967	0.3751	0.9998	0.9921	1.0083	0.0	0.0	0.0	0.0	0.0	0.0	0.0
178.	16	0.968	0.3750	0.9999	0.9921	1.0093	0.0	0.0	0.0	0.0	0.0	0.0	0.0
188.	17	0.968	0.3748	1.0001	0.9922	1.0100	0.0	0.0	0.0	0.0	0.0	0.0	0.0
198.	18	0.967	0.3747	1.0003	0.9922	1.0106	0.0	0.0	0.0	0.0	0.0	0.0	0.0
208.	19	0.967	0.3746	1.0002	0.9922	1.0110	0.0	0.0	0.0	0.0	0.0	0.0	0.0
218.	20	0.967	0.3745	1.0001	0.9920	1.0113	0.0	0.0	0.0	0.0	0.0	0.0	0.0
228.	21	0.967	0.3743	1.0005	0.9923	1.0117	0.0	0.0	0.0	0.0	0.0	0.0	0.0
238.	22	0.967	0.3744	1.0000	0.9919	1.0118	0.0	0.0	0.0	0.0	0.0	0.0	0.0
248.	23	0.968	0.3745	0.9997	0.9916	1.0119	0.0	0.0	0.0	0.0	0.0	0.0	0.0
258.	24	0.969	0.3751	0.9999	0.9921	1.0122	0.0	0.0	0.0	0.0	0.0	0.0	0.0
268.	25	0.974	0.3768	1.0004	0.9934	1.0127	0.0	0.0	0.0	0.0	0.0	0.0	0.0
278.	26	0.984	0.3809	1.0001	0.9953	1.0130	0.0	0.0	0.0	0.0	0.0	0.0	0.0
288.	27	1.005	0.3892	1.0001	0.9996	1.0130	0.0	0.0	0.0	0.0	0.0	0.0	0.0
298.	28	1.032	0.4003	0.9997	1.0051	1.0115	0.0	0.0	0.0	0.0	0.0	0.0	0.0
308.	29	1.037	0.4035	0.9995	1.0067	1.0059	0.0	0.0	0.0	0.0	0.0	0.0	0.0
318.	30	1.035	0.4041	1.0000	1.0076	0.9994	0.0	0.0	0.0	0.0	0.0	0.0	0.0
328.	31	1.034	0.4043	1.0001	1.0078	0.9949	0.0	0.0	0.0	0.0	0.0	0.0	0.0
338.	32	1.033	0.4043	1.0008	1.0085	0.9928	0.0	0.0	0.0	0.0	0.0	0.0	0.0
348.	33	1.033	0.4048	0.9997	1.0077	0.9914	0.0	0.0	0.0	0.0	0.0	0.0	0.0
358.	34	1.033	0.4048	1.0001	1.0081	0.9906	0.0	0.0	0.0	0.0	0.0	0.0	0.0
8.	35	1.034	0.4053	0.9992	1.0075	0.9899	0.0	0.0	0.0	0.0	0.0	0.0	0.0
18.	36	1.033	0.4051	1.0000	1.0081	0.9896	0.0	0.0	0.0	0.0	0.0	0.0	0.0

APPENDIX B (Cont'd)

LOW SPEED OUTPUT													
			COPR FLOW			PRESS RATIO		EFFICIENCY					
LOW SPEED PERFORMANCE 3/2			96.82 LBM/SEC 43.94 KG/SEC			~1.759		0.647					
SAFT CORRECTED PRESSURE RATIO = 4.585													
---- ROW OUTPUT ----													
ICV			FLOW SWIRL = 0.00 DEG			PARTICLE SWIRL = 0.00 DEG			PSAVC = 6.35PSIA = 43812.PA				
PTAVG = 7.27FFSIA = 501.45.PA			TTAVG = 532.6DEG R = 795.9DEG K			VELAVG = 493.7FPS = 150.5MPS			U = 782.FPS = 228.MPS				
FMELAVG = 424.1FPS = 201.4MPS			AXVELAVG = 491.0FPS = 149.7MPS										
THETA	SEC	VFL	MN	PS	PT	TT	WEL	WEL	CF	INCIDENCE	BETA	AXIAL	REL
	NO						LBM/SEC	KG/SEC		IN DEG	IN DEG	VEL	VEL
10.	1	1.023	0.4754	1.0375	1.0439	1.0000	0.0	0.0	-0.119	-0.59	88.6	1.028	0.996
20.	2	1.025	0.4763	1.0369	1.0439	1.0000	0.0	0.0	-0.113	-1.33	87.9	1.030	0.991
30.	3	1.027	0.4772	1.0363	1.0439	1.0000	0.0	0.0	-0.106	-2.12	87.1	1.031	0.985
40.	4	1.029	0.4783	1.0356	1.0439	1.0000	0.0	0.0	-0.098	-3.04	86.2	1.033	0.978
50.	5	1.032	0.4795	1.0348	1.0439	1.0000	0.0	0.0	-0.088	-4.14	85.1	1.034	0.970
60.	6	1.035	0.4812	1.0331	1.0432	1.0000	0.0	0.0	-0.074	-5.52	83.7	1.035	0.959
70.	7	1.041	0.4838	1.0297	1.0415	1.0000	0.0	0.0	-0.055	-7.37	81.6	1.036	0.944
80.	8	1.052	0.4885	1.0208	1.0354	1.0000	0.0	0.0	-0.028	-9.96	79.2	1.039	0.924
90.	9	1.068	0.4964	0.9844	0.9972	1.0000	0.0	0.0	-0.312	-11.02	78.2	1.031	0.914
100.	10	1.096	0.4921	0.9413	0.9652	1.0000	0.0	0.0	-0.656	-9.06	80.1	1.000	0.924
110.	11	1.002	0.4455	0.9606	0.9606	1.0000	0.0	0.0	-0.066	-6.36	82.6	0.999	0.943
120.	12	0.992	0.4408	0.9605	0.9581	1.0000	0.0	0.0	-0.085	-4.47	84.7	0.993	0.956
130.	13	0.984	0.4374	0.9616	0.9574	1.0000	0.0	0.0	-0.099	-3.01	86.2	0.987	0.966
140.	14	0.976	0.4345	0.9627	0.9567	1.0000	0.0	0.0	-0.109	-1.85	87.5	0.982	0.976
150.	15	0.973	0.4320	0.9634	0.9560	1.0000	0.0	0.0	-0.116	-0.84	88.4	0.976	0.980
160.	16	0.968	0.4298	0.9647	0.9556	1.0000	0.0	0.0	-0.125	0.05	89.3	0.973	0.986
170.	17	0.964	0.4280	0.9657	0.9560	1.0000	0.0	0.0	-0.131	1.62	90.0	0.969	0.991
180.	18	0.961	0.4266	0.9665	0.9560	1.0000	0.0	0.0	-0.136	3.54	90.7	0.966	0.994
190.	19	0.958	0.4255	0.9671	0.9560	1.0000	0.0	0.0	-0.141	5.81	91.4	0.963	1.000
200.	20	0.955	0.4235	0.9671	0.9560	1.0000	0.0	0.0	-0.146	8.41	92.1	0.963	1.005
210.	21	0.952	0.4226	0.9670	0.9560	1.0000	0.0	0.0	-0.151	11.4	92.9	0.963	1.011
220.	22	0.948	0.4216	0.9667	0.9560	1.0000	0.0	0.0	-0.157	14.65	93.8	0.963	1.019
230.	23	0.942	0.4207	0.9664	0.9560	1.0000	0.0	0.0	-0.163	18.0	94.0	0.964	1.028
240.	24	0.947	0.4204	0.9662	0.9570	1.0000	0.0	0.0	-0.171	21.35	94.5	0.966	1.041
250.	25	0.945	0.4200	0.9670	0.9630	1.0000	0.0	0.0	-0.179	24.16	94.4	0.970	1.056
260.	26	0.949	0.4203	0.9678	0.9746	1.0000	0.0	0.0	-0.185	26.92	94.1	0.978	1.073
270.	27	1.001	0.4485	0.9955	0.9972	1.0000	0.0	0.0	-0.188	29.02	93.2	0.994	1.088
280.	28	1.011	0.4499	1.0245	1.0270	1.0000	0.0	0.0	-0.185	30.32	92.3	1.000	1.083
290.	29	1.007	0.4481	1.0353	1.0371	1.0000	0.0	0.0	-0.177	30.7	90.0	1.003	1.084
300.	30	1.007	0.4478	1.0391	1.0415	1.0000	0.0	0.0	-0.167	28.75	88.0	1.007	1.089
310.	31	1.008	0.4483	1.0412	1.0432	1.0000	0.0	0.0	-0.159	26.09	84.3	1.011	1.093
320.	32	1.001	0.4493	1.0413	1.0426	1.0000	0.0	0.0	-0.150	23.74	80.0	1.014	1.027
330.	33	1.013	0.4506	1.0405	1.0439	1.0000	0.0	0.0	-0.142	20.65	76.0	1.018	1.019
340.	34	1.016	0.4520	1.0396	1.0439	1.0000	0.0	0.0	-0.137	17.72	72.0	1.021	1.013
350.	35	1.019	0.4532	1.0382	1.0439	1.0000	0.0	0.0	-0.131	15.52	68.1	1.024	1.007
360.	36	1.021	0.4542	1.0362	1.0439	1.0000	0.0	0.0	-0.125	13.15	64.4	1.026	1.002

STAGE 1													
ROT. 1			FLOW SWIRL = 2.26DEG			PARTICLE SWIRL = 2.26DEG			PSAVC = 6.11PSIA = 41451.PA				
PTAVG = 7.27FFSIA = 48389.PA			TTAVG = 532.6DEG R = 795.9DEG K			VELAVG = 528.2FPS = 160.4MPS			U = 785.FPS = 234.MPS				
FMELAVG = 177.4FPS = 70.4MPS			AXVELAVG = 521.0FPS = 158.1MPS										
THETA	SEC	VFL	MN	PS	PT	TT	WEL	WEL	CF	INCIDENCE	BETA	AXIAL	REL
	NO						LBM/SEC	KG/SEC		IN DEG	IN DEG	VEL	VEL
10.	1	1.000	0.4784	1.0445	1.0474	1.0000	0.000	0.000	0.451	5.42	36.3	1.004	1.003
20.	2	1.019	0.4807	1.0442	1.0477	1.0000	0.018	0.008	0.451	5.35	36.3	1.010	1.003
30.	3	1.031	0.4807	1.0439	1.0475	1.0000	0.010	0.006	0.450	5.21	36.3	1.011	1.003
40.	4	1.042	0.4811	1.0436	1.0474	1.0000	0.018	0.008	0.450	5.24	36.4	1.012	1.003
50.	5	1.052	0.4814	1.0434	1.0474	1.0000	0.014	0.008	0.450	5.22	36.4	1.012	1.004
60.	6	1.062	0.4816	1.0424	1.0468	1.0000	0.019	0.008	0.450	5.11	36.4	1.013	1.004
70.	7	1.072	0.4819	1.0400	1.0446	1.0000	0.018	0.008	0.450	5.09	36.4	1.013	1.004
80.	8	1.081	0.4822	1.0385	1.0431	1.0000	0.016	0.008	0.450	5.07	36.4	1.014	1.004
90.	9	1.091	0.4824	0.9941	0.9997	1.0000	0.005	0.002	0.451	5.27	36.5	1.018	1.005
100.	10	1.101	0.4823	0.9972	0.9973	1.0000	-0.015	-0.007	0.452	5.09	36.6	1.021	1.006
110.	11	1.110	0.4824	0.9932	0.9987	1.0000	-0.017	-0.008	0.452	5.15	36.5	1.018	1.005
120.	12	1.119	0.4824	0.9912	0.9985	1.0000	-0.019	-0.008	0.454	5.26	36.4	1.014	1.004
130.	13	1.127	0.4802	0.9915	0.9946	1.0000	-0.019	-0.009	0.457	5.38	36.3	1.010	1.003
140.	14	1.135	0.4792	0.9911	0.9937	1.0000	-0.020	-0.009	0.460	5.51	36.2	1.006	1.002
150.	15	1.142	0.4785	0.9921	0.9927	1.0000	-0.020	-0.009	0.462	5.62	36.1	1.002	1.001
160.	16	1.149	0.4785	0.9920	0.9924	1.0000	-0.021	-0.009	0.464	5.73	36.0	0.999	1.000
170.	17	1.156	0.4780	0.9936	0.9922	1.0000	-0.021	-0.010	0.466	5.82	35.9	0.996	0.999
180.	18	1.163	0.4777	0.9942	0.9921	1.0000	-0.022	-0.010	0.467	5.91	35.8	0.993	0.998
190.	19	1.169	0.4770	0.9946	0.9916	1.0000	-0.022	-0.010	0.468	5.97	35.7	0.991	0.997
200.	20	1.175	0.4769	0.9953	0.9920	1.0000	-0.021	-0.010	0.468	6.02	35.7	0.989	0.997
210.	21	1.181	0.4768	0.9958	0.9921	1.0000	-0.020	-0.009	0.469	6.06	35.6	0.988	0.997
220.	22	1.187	0.4766	0.9963	0.9922	1.0000	-0.020	-0.009	0.469	6.09	35.6	0.987	0.996
230.	23	1.192	0.4765	0.9969	0.9927	1.0000	-0.019	-0.008	0.469	6.11	35.6	0.986	0.996
240.	24	1.197	0.4764	0.9972	0.9929	1.0000	-0.017	-0.008	0.469	6.12	35.6	0.986	0.996
250.	25	1.202	0.4763	0.9981	0.9930	1.0000	-0.015	-0.007	0.469	6.14	35.6	0.985	0.996
260.	26	1.207	0.4762	0.9984	0.9934	1.0000	-0.014	-0.006	0.468	6.17	35.5	0.984	0.995
270.	27	1.211	0.4761	1.0039	0.9982	1.0000	-0.007	0.003	0.467	6.23	35.5	0.982	0.995
280.	28	1.215	0.4760	1.0038	1.0024	1.0000	0.016	0.007	0.466	6.21	35.4	0.980	0.994
290.	29	1.219	0.4760	1.0045	1.0037	1.0000	0.016	0.008	0.465	6.21	35.5	0.983	0.995
300.	30	1.223	0.4760	1.0040	1.0036	1.0000	0.019	0.008	0.462	6.09	35.6	0.987	0.996
310.	31	1.227	0.4760	1.0047	1.0037	1.0000	0.018	0.008	0.460	5.95	35.7	0.991	0.997
320.	32	1.231	0.4760	1.0042	1.0047	1.0000	0.018	0.008	0.457	5.82	35.9	0.995	0.999
330.	33	1.234	0.4760	1.0042	1.0046	1.0000	0.017	0.008	0.454	5.71	36.0	0.999	1.000
340.	34	1.237	0.4760	1.0040	1.0047	1.0000	0.017	0.008	0.453	5.63	36.1	1.003	1.001
350.	35	1.240	0.4760	1.0040	1.0047	1.0000	0.017	0.008	0.453	5.55	36.2	1.005	1.001
360.	36	1.243	0.4760	1.0040	1.0047	1.0000	0.017	0.008	0.452	5.47	36.2	1.007	1.002

APPENDIX B (Cont'd)

MAP OF HORIZONTAL COORDINATES
 2000 0000 0000
 2000 0000 0000

STATUS:

FLOW SWIRL = 4.24DEG PARTICLE SWIRL = 18.54DEG PSAVC = 7.0E+PSIA = 48826.PA
 PTAVC = 9.15E+PSIA = 63101.PA TTAVC = 576.4DEG R = 320.2DEG K VELAVC = 659.6FPS = 213.2MPS
 FVELAVC = (18.6FPS = 188.6MPS AXVELAVC = 529.7FPS = 161.5MPS U = 776.FPS = 237.MPS

THETA	SIG	VEL	MN	PS	PT	TT	WBL	WBL	DF	INCIDENCE	ALPHA	AXIAL	REL
DEG	MG						LRM/SEC	KG/SEC		IN DEG	IN DEG	VEL	VEL
14.	1	1.005	0.6199	1.0413	1.0441	0.9986	0.0	0.0	0.422	-9.35	49.8	1.011	1.011
24.	2	1.004	0.6198	1.0415	1.0443	0.9986	0.0	0.0	0.421	-9.39	49.8	1.012	1.012
34.	3	1.004	0.6197	1.0416	1.0443	0.9986	0.0	0.0	0.420	-9.42	49.8	1.012	1.012
44.	4	1.004	0.6196	1.0417	1.0443	0.9986	0.0	0.0	0.419	-9.44	49.8	1.013	1.013
54.	5	1.004	0.6196	1.0417	1.0443	0.9986	0.0	0.0	0.419	-9.44	49.9	1.013	1.013
64.	6	1.004	0.6196	1.0408	1.0434	0.9986	0.0	0.0	0.419	-9.47	49.9	1.013	1.013
74.	7	1.004	0.6196	1.0386	1.0411	0.9986	0.0	0.0	0.418	-9.48	49.9	1.014	1.014
84.	8	1.005	0.6197	1.0312	1.0339	0.9986	0.0	0.0	0.418	-9.48	49.9	1.014	1.014
94.	9	1.000	0.6204	0.9870	0.9901	0.9870	0.0	0.0	0.419	-9.42	49.8	1.012	1.012
104.	10	0.997	0.6197	0.9509	0.9534	0.9870	0.0	0.0	0.419	-9.39	49.8	1.012	1.012
114.	11	0.998	0.6172	0.9549	0.9555	0.9928	0.0	0.0	0.420	-9.37	49.8	1.011	1.011
124.	12	0.998	0.6155	0.9567	0.9559	0.9983	0.0	0.0	0.424	-9.23	49.8	1.008	1.008
134.	13	0.997	0.6143	0.9584	0.9567	0.9996	0.0	0.0	0.429	-9.02	49.4	1.004	1.004
144.	14	0.996	0.6135	0.9591	0.9564	1.0003	0.0	0.0	0.433	-8.83	49.2	1.000	1.000
154.	15	0.995	0.6128	0.9592	0.9564	1.0006	0.0	0.0	0.437	-8.65	49.1	0.996	0.996
164.	16	0.995	0.6124	0.9595	0.9564	1.0019	0.0	0.0	0.440	-8.51	48.9	0.994	0.994
174.	17	0.994	0.6123	0.9595	0.9563	1.0019	0.0	0.0	0.442	-8.40	48.8	0.991	0.991
184.	18	0.994	0.6122	0.9593	0.9560	1.0014	0.0	0.0	0.444	-8.31	48.7	0.989	0.989
194.	19	0.993	0.6123	0.9589	0.9557	1.0014	0.0	0.0	0.444	-8.24	48.6	0.988	0.988
204.	20	0.993	0.6124	0.9590	0.9558	1.0016	0.0	0.0	0.447	-8.19	48.6	0.987	0.987
214.	21	0.993	0.6125	0.9589	0.9558	1.0016	0.0	0.0	0.447	-8.15	48.6	0.986	0.986
224.	22	0.993	0.6126	0.9587	0.9558	1.0016	0.0	0.0	0.446	-8.15	48.5	0.986	0.986
234.	23	0.993	0.6126	0.9588	0.9564	1.0016	0.0	0.0	0.448	-8.12	48.5	0.985	0.985
244.	24	0.994	0.6131	0.9597	0.9571	1.0018	0.0	0.0	0.448	-8.12	48.5	0.985	0.985
254.	25	0.997	0.6132	0.9671	0.9645	1.0035	0.0	0.0	0.447	-8.15	48.5	0.986	0.986
264.	26	0.990	0.6133	0.9710	0.9715	1.0060	0.0	0.0	0.447	-8.19	48.6	0.987	0.987
274.	27	1.000	0.6135	1.0061	1.0054	1.0103	0.0	0.0	0.446	-8.22	48.6	0.987	0.987
284.	28	1.003	0.6138	1.0090	1.0067	1.0137	0.0	0.0	0.445	-8.26	48.7	0.987	0.987
294.	29	1.003	0.6161	1.0074	1.0020	1.0071	0.0	0.0	0.443	-8.36	48.8	0.990	0.990
304.	30	1.003	0.6179	1.0417	1.0429	1.0024	0.0	0.0	0.440	-8.53	48.9	0.994	0.994
314.	31	1.004	0.6191	1.0411	1.0432	1.0005	0.0	0.0	0.436	-8.72	49.1	0.996	0.996
324.	32	1.005	0.6157	1.0406	1.0433	0.9995	0.0	0.0	0.432	-8.84	49.2	1.001	1.001
334.	33	1.005	0.6201	1.0402	1.0431	0.9997	0.0	0.0	0.429	-9.04	49.4	1.004	1.004
344.	34	1.005	0.6201	1.0403	1.0433	0.9996	0.0	0.0	0.426	-9.15	49.4	1.007	1.007
354.	35	1.005	0.6201	1.0406	1.0436	0.9987	0.0	0.0	0.424	-9.24	49.4	1.009	1.009
4.	0	1.005	0.6200	1.0410	1.0436	0.9986	0.0	0.0	0.423	-9.30	49.7	1.010	1.010

STATUS:
 ROTATE

FLOW SWIRL = 5.00DEG PARTICLE SWIRL = 25.20DEG PSAVC = 7.67E+PSIA = 52190.PA
 PTAVC = 6.45E+PSIA = 61520.PA TTAVC = 576.4DEG R = 320.2DEG K VELAVC = 541.3FPS = 165.0MPS
 FVELAVC = 174.0FPS = 266.4MPS AXVELAVC = 535.3FPS = 163.2MPS U = 771.FPS = 235.MPS

THETA	SIG	VEL	MN	PS	PT	TT	WBL	WBL	DF	INCIDENCE	BETA	AXIAL	REL
DEG	MG						LRM/SEC	KG/SEC		IN DEG	IN DEG	VEL	VEL
14.	1	1.014	0.4768	1.0303	1.0426	0.9986	0.0	0.0	0.437	0.91	38.2	1.014	1.004
24.	2	1.015	0.4775	1.0361	1.0430	0.9986	0.0	0.0	0.436	0.87	38.2	1.015	1.004
34.	3	1.015	0.4778	1.0380	1.0431	0.9986	0.0	0.0	0.436	0.85	38.3	1.015	1.005
44.	4	1.016	0.4781	1.0376	1.0431	0.9986	0.0	0.0	0.435	0.83	38.3	1.016	1.005
54.	5	1.017	0.4783	1.0377	1.0432	0.9986	0.0	0.0	0.435	0.81	38.3	1.017	1.005
64.	6	1.017	0.4785	1.0366	1.0433	0.9986	0.0	0.0	0.435	0.80	38.3	1.017	1.005
74.	7	1.017	0.4785	1.0342	1.0430	0.9986	0.0	0.0	0.435	0.79	38.3	1.017	1.005
84.	8	1.017	0.4792	1.0267	1.0432	0.9986	0.0	0.0	0.435	0.79	38.3	1.017	1.005
94.	9	1.017	0.4815	0.9817	0.9869	0.9870	0.0	0.0	0.436	0.80	38.3	1.017	1.005
104.	10	1.017	0.4822	0.9454	0.9527	0.9841	0.0	0.0	0.442	0.81	38.3	1.017	1.005
114.	11	1.015	0.4788	0.9505	0.9558	0.9938	0.0	0.0	0.445	0.86	38.2	1.015	1.005
124.	12	1.011	0.4755	0.9537	0.9571	0.9992	0.0	0.0	0.447	0.99	38.1	1.011	1.003
134.	13	1.009	0.4724	0.9570	0.9564	0.9997	0.0	0.0	0.450	1.17	37.9	1.005	1.007
144.	14	1.000	0.4697	0.9589	0.9588	1.0007	0.0	0.0	0.453	1.33	37.4	1.000	1.000
154.	15	0.995	0.4674	0.9600	0.9585	1.0006	0.0	0.0	0.455	1.47	37.0	0.995	0.998
164.	16	0.992	0.4655	0.9612	0.9585	1.0010	0.0	0.0	0.457	1.58	37.5	0.992	0.997
174.	17	0.989	0.4640	0.9619	0.9583	1.0013	0.0	0.0	0.458	1.67	37.4	0.989	0.997
184.	18	0.987	0.4624	0.9622	0.9579	1.0014	0.0	0.0	0.459	1.74	37.4	0.987	0.996
194.	19	0.985	0.4620	0.9623	0.9575	1.0014	0.0	0.0	0.460	1.80	37.3	0.985	0.995
204.	20	0.983	0.4615	0.9627	0.9575	1.0016	0.0	0.0	0.461	1.84	37.3	0.983	0.995
214.	21	0.982	0.4609	0.9629	0.9574	1.0016	0.0	0.0	0.461	1.87	37.2	0.983	0.995
224.	22	0.982	0.4606	0.9625	0.9572	1.0016	0.0	0.0	0.461	1.89	37.2	0.982	0.995
234.	23	0.982	0.4605	0.9631	0.9573	1.0016	0.0	0.0	0.461	1.91	37.2	0.982	0.995
244.	24	0.982	0.4605	0.9640	0.9583	1.0018	0.0	0.0	0.461	1.89	37.2	0.982	0.995
254.	25	0.983	0.4604	0.9712	0.9654	1.0035	0.0	0.0	0.459	1.89	37.2	0.983	0.995
264.	26	0.983	0.4605	0.9850	0.9790	1.0060	0.0	0.0	0.458	1.84	37.2	0.983	0.995
274.	27	0.984	0.4597	1.0126	1.0154	1.0103	0.0	0.0	0.455	1.81	37.3	0.984	0.995
284.	28	0.985	0.4594	1.0428	1.0460	1.0131	0.0	0.0	0.452	1.76	37.3	0.985	0.995
294.	29	0.986	0.4621	1.0460	1.0409	1.0071	0.0	0.0	0.449	1.71	37.4	0.986	0.996
304.	30	0.991	0.4682	1.0447	1.0415	1.0024	0.0	0.0	0.447	1.58	37.5	0.992	0.997
314.	31	0.997	0.4680	1.0429	1.0417	1.0005	0.0	0.0	0.445	1.43	37.7	0.997	0.999
324.	32	1.001	0.4705	1.0414	1.0417	0.9995	0.0	0.0	0.442	1.29	37.8	1.001	1.000
334.	33	1.005	0.4724	1.0400	1.0416	0.9997	0.0	0.0	0.441	1.18	37.6	1.005	1.002
344.	34	1.008	0.4747	1.0392	1.0418	0.9985	0.0	0.0	0.439	1.08	38.0	1.008	1.002
354.	35	1.010	0.4752	1.0388	1.0422	0.9987	0.0	0.0	0.438	1.01	38.1	1.010	1.003
4.	0	1.010	0.4761	1.0385	1.0425	0.9986	0.0	0.0	0.437	0.95	38.1	1.010	1.004

APPENDIX B (Cont'd)

STACK
RTIME

FLOW SWIRL= 54.220EG PARTICLE SWIRL= 23.00DEG PSAVG= 9.15PSIA = 6333E-PA
 STAVG= 11.12FPSIA = 705E-PA TTAVG= 620.6DEG R = 344.8DEG K VELAVG= 467.3FPS = 203.4MPS
 FWLAVG= 617.1FPS = 1P64MPS AXVELAVG= 511.1FPS = 157.6MPS U= 785.FPS = 333.MPS

THETA	SEG NO	VEL	MN	PS	PT	TT	WBL LBM/SEC	WEL KG/SEC	DF	INCIDENCE IN DEG	BETA IN DEG	AXIAL VEL	REL VEL
23.	1	1.005	0.4403	1.0231	1.0366	0.9945	0.0	0.0	0.445	-10.37	50.8	1.015	1.015
23.	2	1.005	0.4403	1.0231	1.0366	0.9945	0.0	0.0	0.445	-10.41	50.8	1.016	1.016
23.	3	1.005	0.4403	1.0231	1.0366	0.9945	0.0	0.0	0.445	-10.45	50.8	1.017	1.017
23.	4	1.005	0.4403	1.0231	1.0366	0.9945	0.0	0.0	0.445	-10.47	50.9	1.017	1.017
23.	5	1.005	0.4403	1.0231	1.0366	0.9945	0.0	0.0	0.441	-10.49	50.9	1.018	1.018
23.	6	1.005	0.4403	1.0231	1.0366	0.9945	0.0	0.0	0.441	-10.51	50.9	1.018	1.018
23.	7	1.005	0.4403	1.0231	1.0366	0.9945	0.0	0.0	0.441	-10.51	50.9	1.018	1.018
23.	8	1.005	0.4403	1.0231	1.0366	0.9945	0.0	0.0	0.441	-10.51	50.9	1.018	1.018
23.	9	1.005	0.4403	1.0231	1.0366	0.9945	0.0	0.0	0.441	-10.51	50.9	1.018	1.018
23.	10	1.005	0.4403	1.0231	1.0366	0.9945	0.0	0.0	0.445	-10.32	50.7	1.014	1.014
23.	11	1.005	0.4403	1.0231	1.0366	0.9945	0.0	0.0	0.450	-10.07	50.5	1.009	1.009
23.	12	1.005	0.4403	1.0231	1.0366	0.9945	0.0	0.0	0.455	-9.90	50.3	1.006	1.006
23.	13	1.005	0.4403	1.0231	1.0366	0.9945	0.0	0.0	0.460	-9.74	50.1	1.003	1.003
23.	14	1.005	0.4403	1.0231	1.0366	0.9945	0.0	0.0	0.465	-9.53	49.9	0.998	0.998
23.	15	1.005	0.4403	1.0231	1.0366	0.9945	0.0	0.0	0.471	-9.31	49.7	0.994	0.994
23.	16	1.005	0.4403	1.0231	1.0366	0.9945	0.0	0.0	0.476	-9.13	49.5	0.990	0.990
23.	17	1.005	0.4403	1.0231	1.0366	0.9945	0.0	0.0	0.480	-8.98	49.4	0.988	0.988
23.	18	1.005	0.4403	1.0231	1.0366	0.9945	0.0	0.0	0.482	-8.88	49.3	0.985	0.985
23.	19	1.005	0.4403	1.0231	1.0366	0.9945	0.0	0.0	0.484	-8.80	49.2	0.984	0.984
23.	20	1.005	0.4403	1.0231	1.0366	0.9945	0.0	0.0	0.486	-8.73	49.1	0.983	0.983
23.	21	1.005	0.4403	1.0231	1.0366	0.9945	0.0	0.0	0.487	-8.69	49.1	0.982	0.982
23.	22	1.005	0.4403	1.0231	1.0366	0.9945	0.0	0.0	0.488	-8.66	49.1	0.981	0.981
23.	23	1.005	0.4403	1.0231	1.0366	0.9945	0.0	0.0	0.488	-8.66	49.1	0.981	0.981
23.	24	1.005	0.4403	1.0231	1.0366	0.9945	0.0	0.0	0.488	-8.70	49.1	0.982	0.982
23.	25	1.005	0.4403	1.0231	1.0366	0.9945	0.0	0.0	0.485	-8.77	49.2	0.983	0.983
23.	26	1.005	0.4403	1.0231	1.0366	0.9945	0.0	0.0	0.482	-8.89	49.3	0.986	0.986
23.	27	1.005	0.4403	1.0231	1.0366	0.9945	0.0	0.0	0.478	-9.04	49.4	0.989	0.989
23.	28	1.005	0.4403	1.0231	1.0366	0.9945	0.0	0.0	0.474	-9.22	49.6	0.992	0.992
23.	29	1.005	0.4403	1.0231	1.0366	0.9945	0.0	0.0	0.469	-9.43	49.8	0.996	0.996
23.	30	1.005	0.4403	1.0231	1.0366	0.9945	0.0	0.0	0.465	-9.60	50.0	1.000	1.000
23.	31	1.005	0.4403	1.0231	1.0366	0.9945	0.0	0.0	0.461	-9.76	50.2	1.003	1.003
23.	32	1.005	0.4403	1.0231	1.0366	0.9945	0.0	0.0	0.457	-9.93	50.3	1.006	1.006
23.	33	1.005	0.4403	1.0231	1.0366	0.9945	0.0	0.0	0.453	-10.07	50.5	1.009	1.009
23.	34	1.005	0.4403	1.0231	1.0366	0.9945	0.0	0.0	0.450	-10.18	50.6	1.011	1.011
23.	35	1.005	0.4403	1.0231	1.0366	0.9945	0.0	0.0	0.446	-10.26	50.7	1.013	1.013
23.	36	1.005	0.4403	1.0231	1.0366	0.9945	0.0	0.0	0.446	-10.32	50.7	1.014	1.014

STACK
RTIME

FLOW SWIRL= 13.167EG PARTICLE SWIRL= 37.43DFG PSAVG= 9.79PSIA = 67479-PA
 STAVG= 11.12FPSIA = 76E-PA TTAVG= 620.6DEG R = 344.8DEG K VELAVG= 517.1FPS = 157.6MPS
 FWLAVG= 107.2FPS = 275.6MPS AXVELAVG= 516.6FPS = 157.6MPS U= 757.FPS = 231.MPS

THETA	SEG NO	VEL	MN	PS	PT	TT	WBL LBM/SEC	WEL KG/SEC	DF	INCIDENCE IN DEG	BETA IN DEG	AXIAL VEL	REL VEL
23.	1	1.023	0.4429	1.0241	1.0309	0.9949	0.0	0.0	0.463	-0.68	35.8	1.023	1.007
23.	2	1.025	0.4426	1.0233	1.0306	0.9947	0.0	0.0	0.462	-0.72	35.6	1.025	1.008
23.	3	1.026	0.4441	1.0227	1.0303	0.9945	0.0	0.0	0.461	-0.75	35.8	1.026	1.008
23.	4	1.027	0.4445	1.0221	1.0300	0.9943	0.0	0.0	0.460	-0.77	35.9	1.027	1.008
23.	5	1.027	0.4449	1.0217	1.0297	0.9942	0.0	0.0	0.460	-0.79	35.9	1.027	1.009
23.	6	1.028	0.4452	1.0204	1.0286	0.9939	0.0	0.0	0.460	-0.80	35.9	1.028	1.009
23.	7	1.028	0.4454	1.0179	1.0262	0.9933	0.0	0.0	0.460	-0.81	35.9	1.028	1.009
23.	8	1.028	0.4457	1.0166	1.0191	0.9916	0.0	0.0	0.461	-0.80	35.9	1.028	1.009
23.	9	1.023	0.4462	0.9692	0.9776	0.9807	0.0	0.0	0.470	-0.68	35.8	1.023	1.007
23.	10	1.016	0.4446	0.9360	0.9433	0.9736	0.0	0.0	0.481	-0.48	35.6	1.016	1.005
23.	11	1.011	0.4400	0.9442	0.9489	0.9824	0.0	0.0	0.487	-0.33	35.4	1.011	1.003
23.	12	1.005	0.4351	0.9546	0.9565	0.9927	0.0	0.0	0.492	-0.17	35.3	1.005	1.001
23.	13	0.998	0.4306	0.9637	0.9632	0.9987	0.0	0.0	0.495	0.03	35.1	0.998	0.999
23.	14	0.991	0.4271	0.9691	0.9665	1.0009	0.0	0.0	0.498	0.22	34.9	0.991	0.997
23.	15	0.985	0.4242	0.9726	0.9685	1.0024	0.0	0.0	0.502	0.38	34.7	0.985	0.995
23.	16	0.981	0.4220	0.9753	0.9699	1.0035	0.0	0.0	0.504	0.50	34.6	0.981	0.994
23.	17	0.978	0.4203	0.9771	0.9707	1.0045	0.0	0.0	0.506	0.59	34.5	0.978	0.993
23.	18	0.975	0.4191	0.9780	0.9710	1.0051	0.0	0.0	0.507	0.66	34.4	0.975	0.992
23.	19	0.973	0.4181	0.9787	0.9712	1.0056	0.0	0.0	0.508	0.72	34.4	0.973	0.992
23.	20	0.972	0.4175	0.9793	0.9714	1.0060	0.0	0.0	0.508	0.75	34.3	0.972	0.991
23.	21	0.971	0.4170	0.9797	0.9715	1.0063	0.0	0.0	0.509	0.78	34.3	0.971	0.991
23.	22	0.971	0.4169	0.9795	0.9713	1.0064	0.0	0.0	0.508	0.79	34.3	0.971	0.991
23.	23	0.971	0.4169	0.9793	0.9711	1.0064	0.0	0.0	0.508	0.78	34.3	0.971	0.991
23.	24	0.972	0.4174	0.9792	0.9713	1.0065	0.0	0.0	0.506	0.75	34.3	0.972	0.991
23.	25	0.974	0.4180	0.9848	0.9772	1.0081	0.0	0.0	0.504	0.69	34.4	0.974	0.992
23.	26	0.978	0.4189	0.9964	0.9891	1.0111	0.0	0.0	0.499	0.59	34.5	0.978	0.993
23.	27	0.982	0.4198	1.0208	1.0138	1.0166	0.0	0.0	0.493	0.46	34.6	0.982	0.994
23.	28	0.988	0.4213	1.0486	1.0424	1.0211	0.0	0.0	0.486	0.31	34.8	0.988	0.996
23.	29	0.993	0.4248	1.0494	1.0452	1.0161	0.0	0.0	0.480	0.16	34.9	0.993	0.998
23.	30	0.998	0.4285	1.0441	1.0422	1.0082	0.0	0.0	0.476	0.02	35.1	0.998	0.999
23.	31	1.003	0.4322	1.0376	1.0379	1.0021	0.0	0.0	0.474	-0.12	35.2	1.003	1.001
23.	32	1.009	0.4353	1.0328	1.0351	0.9992	0.0	0.0	0.471	-0.27	35.4	1.009	1.003
23.	33	1.013	0.4377	1.0294	1.0331	0.9974	0.0	0.0	0.468	-0.40	35.5	1.013	1.004
23.	34	1.017	0.4396	1.0272	1.0325	0.9963	0.0	0.0	0.466	-0.50	35.6	1.017	1.005
23.	35	1.020	0.4410	1.0258	1.0314	0.9957	0.0	0.0	0.465	-0.57	35.7	1.020	1.006
23.	36	1.022	0.4420	1.0249	1.0312	0.9953	0.0	0.0	0.464	-0.63	35.7	1.022	1.007

APPENDIX B (Cont'd)

STATOR

FLOW SWIRL= 14.63DEG PARTICLE SWIRL= 49.22DEG PSAVG= 11.64PSIA = 80241.PA
 PTAVG= 14.15PSIA = 97579.PA TTAVG= 669.5DEG R = 371.9DEG K VELAUG= 661.4FPS = 201.6MPS
 PVLAUG= 612.2FPS = 186.6MPS AXVELAUG= 516.3FPS = 157.4MPS U= 739.FPS = 225.MPS

THETA	SEG	VEL	MN	PS	PT	TT	WBL	WBL	DF	INCIDENCE	ALPHA	AXIAL	REL
	NO						LBM/SEC	KG/SEC		IN DEG	IN DEG	VEL	VEL
25.	1	1.005	0.5418	1.0146	1.0184	0.9906	0.003	0.002	0.275	-1.45	52.7	1.024	1.024
35.	2	1.005	0.5419	1.0137	1.0176	0.9900	0.004	0.002	0.274	-1.50	52.8	1.026	1.026
45.	3	1.004	0.5420	1.0130	1.0169	0.9896	0.004	0.002	0.273	-1.54	52.8	1.026	1.026
55.	4	1.004	0.5419	1.0121	1.0160	0.9891	0.004	0.002	0.272	-1.57	52.9	1.027	1.027
65.	5	1.004	0.5420	1.0109	1.0148	0.9887	0.004	0.002	0.272	-1.59	52.9	1.027	1.027
75.	6	1.004	0.5421	1.0086	1.0126	0.9880	0.004	0.002	0.272	-1.61	52.9	1.028	1.028
85.	7	1.003	0.5424	1.0022	1.0064	0.9862	0.003	0.001	0.273	-1.57	52.9	1.027	1.027
95.	8	1.001	0.5464	0.9389	0.9455	0.9786	-0.004	-0.002	0.277	-1.34	52.6	1.022	1.022
105.	9	0.998	0.5426	0.9472	0.9513	0.9746	-0.008	-0.004	0.286	-0.89	52.2	1.013	1.013
115.	10	0.996	0.5384	0.9587	0.9600	0.9853	-0.008	-0.004	0.294	-0.50	51.8	1.005	1.005
125.	11	0.996	0.5350	0.9716	0.9705	0.9966	-0.008	-0.004	0.300	-0.18	51.5	0.999	0.999
135.	12	0.995	0.5331	0.9796	0.9771	1.0028	-0.005	-0.003	0.305	0.10	51.2	0.994	0.994
145.	13	0.995	0.5321	0.9839	0.9808	1.0055	-0.005	-0.002	0.310	0.41	50.9	0.987	0.987
155.	14	0.995	0.5316	0.9863	0.9828	1.0073	-0.005	-0.002	0.315	0.68	50.6	0.982	0.982
165.	15	0.995	0.5312	0.9878	0.9841	1.0087	-0.004	-0.002	0.318	0.86	50.4	0.978	0.978
175.	16	0.995	0.5309	0.9886	0.9846	1.0097	-0.004	-0.002	0.321	1.00	50.3	0.976	0.976
185.	17	0.995	0.5306	0.9893	0.9851	1.0105	-0.004	-0.002	0.322	1.11	50.2	0.974	0.974
195.	18	0.995	0.5305	0.9894	0.9852	1.0110	-0.003	-0.002	0.324	1.20	50.1	0.972	0.972
205.	19	0.995	0.5304	0.9896	0.9853	1.0114	-0.003	-0.002	0.324	1.25	50.1	0.971	0.971
215.	20	0.995	0.5304	0.9891	0.9847	1.0115	-0.003	-0.002	0.325	1.29	50.0	0.970	0.970
225.	21	0.995	0.5304	0.9884	0.9840	1.0115	-0.002	-0.001	0.325	1.30	50.0	0.970	0.970
235.	22	0.995	0.5304	0.9875	0.9831	1.0113	-0.001	-0.001	0.324	1.29	50.0	0.970	0.970
245.	23	0.995	0.5301	0.9917	0.9872	1.0127	0.0	0.0	0.323	1.24	50.1	0.971	0.971
255.	24	0.996	0.5301	1.0003	0.9951	1.0151	0.002	0.001	0.319	1.14	50.2	0.973	0.973
265.	25	0.998	0.5298	1.0213	1.0163	1.0204	0.004	0.002	0.312	0.91	50.4	0.978	0.978
275.	26	1.001	0.5299	1.0454	1.0404	1.0254	0.006	0.003	0.305	0.59	50.7	0.984	0.984
285.	27	1.003	0.5325	1.0452	1.0421	1.0218	0.006	0.003	0.298	0.19	51.1	0.992	0.992
295.	28	1.005	0.5385	1.0402	1.0393	1.0147	0.006	0.003	0.293	-0.43	51.5	0.999	0.999
305.	29	1.006	0.5383	1.0316	1.0328	1.0054	0.005	0.002	0.289	-0.65	51.7	1.004	1.004
315.	30	1.005	0.5400	1.0244	1.0269	0.9987	0.004	0.002	0.285	-0.86	51.9	1.008	1.008
325.	31	1.005	0.5409	1.0202	1.0233	0.9954	0.004	0.002	0.282	-1.05	52.2	1.013	1.013
335.	32	1.005	0.5414	1.0177	1.0212	0.9933	0.004	0.002	0.279	-1.19	52.3	1.016	1.016
345.	33	1.005	0.5416	1.0163	1.0199	0.9921	0.004	0.002	0.277	-1.30	52.5	1.019	1.019
355.	34	1.005	0.5417	1.0155	1.0192	0.9912	0.003	0.002	0.276	-1.38	52.6	1.021	1.021

STAGE 4
 ROTOR

FLOW SWIRL= 18.94DEG PARTICLE SWIRL= 53.00DEG PSAVG= 12.21PSIA = 84186.PA
 PTAVG= 14.17PSIA = 97674.PA TTAVG= 669.5DEG R = 371.9DEG K VELAUG= 578.0FPS = 176.2MPS
 PVLAUG= 842.7FPS = 256.0MPS AXVELAUG= 570.1FPS = 173.8MPS U= 716.FPS = 218.MPS

THETA	SEG	VEL	MN	PS	PT	TT	WBL	WBL	DF	INCIDENCE	BETA	AXIAL	REL
	NO						LBM/SEC	KG/SEC		IN DEG	IN DEG	VEL	VEL
29.	1	1.026	0.4806	1.0141	1.0234	0.9906	0.0	0.0	0.275	-3.51	43.4	1.026	1.010
39.	2	1.027	0.4812	1.0133	1.0230	0.9900	0.0	0.0	0.274	-3.55	43.4	1.027	1.010
49.	3	1.028	0.4818	1.0125	1.0226	0.9896	0.0	0.0	0.273	-3.58	43.5	1.028	1.010
59.	4	1.028	0.4821	1.0120	1.0224	0.9894	0.0	0.0	0.273	-3.60	43.5	1.028	1.011
69.	5	1.029	0.4824	1.0117	1.0222	0.9891	0.0	0.0	0.273	-3.61	43.5	1.029	1.011
79.	6	1.029	0.4826	1.0106	1.0212	0.9887	0.0	0.0	0.273	-3.62	43.5	1.029	1.011
89.	7	1.029	0.4828	1.0083	1.0190	0.9880	0.0	0.0	0.273	-3.62	43.5	1.029	1.011
99.	8	1.028	0.4828	1.0021	1.0128	0.9862	0.0	0.0	0.274	-3.62	43.5	1.029	1.011
109.	9	1.023	0.4830	0.9671	0.9776	0.9758	0.0	0.0	0.283	-3.59	43.5	1.028	1.011
119.	10	1.013	0.4798	0.9405	0.9487	0.9686	0.0	0.0	0.299	-3.43	43.3	1.023	1.009
129.	11	1.004	0.4738	0.9494	0.9540	0.9746	0.0	0.0	0.309	-3.10	43.0	1.013	1.005
139.	12	0.997	0.4678	0.9608	0.9619	0.9853	0.0	0.0	0.315	-2.80	42.7	1.004	1.001
149.	13	0.992	0.4625	0.9730	0.9709	0.9966	0.0	0.0	0.318	-2.59	42.5	0.997	0.999
159.	14	0.986	0.4582	0.9807	0.9759	1.0028	0.0	0.0	0.322	-2.40	42.3	0.992	0.997
169.	15	0.981	0.4551	0.9848	0.9781	1.0055	0.0	0.0	0.325	-2.21	42.1	0.986	0.995
179.	16	0.977	0.4529	0.9871	0.9791	1.0073	0.0	0.0	0.327	-2.04	41.9	0.981	0.993
189.	17	0.975	0.4514	0.9884	0.9795	1.0087	0.0	0.0	0.328	-1.92	41.8	0.977	0.991
199.	18	0.973	0.4503	0.9889	0.9793	1.0097	0.0	0.0	0.328	1.83	41.7	0.975	0.991
209.	19	0.971	0.4494	0.9893	0.9792	1.0105	0.0	0.0	0.330	-1.77	41.7	0.973	0.990
219.	20	0.970	0.4489	0.9893	0.9788	1.0110	0.0	0.0	0.331	-1.69	41.6	0.971	0.989
229.	21	0.970	0.4485	0.9893	0.9787	1.0114	0.0	0.0	0.331	-1.67	41.6	0.970	0.989
239.	22	0.970	0.4484	0.9887	0.9780	1.0115	0.0	0.0	0.331	-1.67	41.6	0.970	0.989
249.	23	0.970	0.4485	0.9881	0.9774	1.0115	0.0	0.0	0.331	-1.67	41.6	0.970	0.989
259.	24	0.971	0.4480	0.9873	0.9768	1.0113	0.0	0.0	0.330	-1.70	41.6	0.971	0.989
269.	25	0.972	0.4494	0.9918	0.9817	1.0127	0.0	0.0	0.327	-1.76	41.6	0.972	0.990
279.	26	0.977	0.4510	1.0005	0.9912	1.0151	0.0	0.0	0.322	-1.90	41.7	0.972	0.990
289.	27	0.983	0.4530	1.0210	1.0127	1.0204	0.0	0.0	0.313	-2.13	42.0	0.977	0.991
299.	28	0.992	0.4558	1.0446	1.0378	1.0254	0.0	0.0	0.303	-2.40	42.3	0.983	0.994
309.	29	0.999	0.4602	1.0440	1.0402	1.0218	0.0	0.0	0.295	-2.65	42.6	0.999	1.000
319.	30	1.005	0.4646	1.0390	1.0379	1.0147	0.0	0.0	0.290	-2.84	42.7	1.005	1.002
329.	31	1.004	0.4689	1.0307	1.0325	1.0054	0.0	0.0	0.284	-2.98	42.9	1.009	1.003
339.	32	1.013	0.4726	1.0238	1.0279	0.9987	0.0	0.0	0.284	-3.12	43.0	1.013	1.005
349.	33	1.017	0.4753	1.0196	1.0256	0.9994	0.0	0.0	0.281	-3.25	43.1	1.017	1.006
359.	34	1.020	0.4773	1.0172	1.0244	0.9933	0.0	0.0	0.279	-3.35	43.2	1.020	1.008
369.	35	1.022	0.4787	1.0158	1.0230	0.9921	0.0	0.0	0.278	-3.41	43.3	1.023	1.008
379.	36	1.024	0.4797	1.0150	1.0238	0.9912	0.0	0.0	0.276	-3.47	43.4	1.024	1.009

APPENDIX B (Cont'd)

STATOR

FLOW SWIRL = 18.74DEG PARTICLE SWIRL = 57.79DEG PSAVG = 13.45PSIA = 92726.PA

PTAVG = 16.33PSIA = 112573.PA TTAVG = 704.5DEG P = 391.4DEG K VELAVG = 675.5FPS = 205.9MPS
 RVELAVG = 763.5FPS = 214.4MPS AXVELAVG = 592.9FPS = 180.7MPS U = 762.FPS = 214.MPS

THETA	SEG NO	VEL	MN	PS	PT	TT	WFL LBM/SEC	WEL KG/SEC	DF	INCIDENCE IN DEG	BETA IN DEG	AXIAL VEL	REL VEL
29.	1	1.016	0.5463	1.0081	1.0166	0.9496	0.0	0.0	0.195	-4.26	63.0	1.031	1.631
30.	2	1.016	0.5467	1.0072	1.0160	0.9490	0.0	0.0	0.194	-4.33	63.0	1.032	1.632
40.	3	1.017	0.5471	1.0064	1.0155	0.9485	0.0	0.0	0.193	-4.38	63.1	1.033	1.633
50.	4	1.017	0.5473	1.0059	1.0152	0.9482	0.0	0.0	0.193	-4.41	63.1	1.033	1.633
60.	5	1.017	0.5474	1.0057	1.0150	0.9480	0.0	0.0	0.192	-4.42	63.1	1.033	1.633
70.	6	1.017	0.5475	1.0046	1.0141	0.9476	0.0	0.0	0.192	-4.43	63.1	1.034	1.634
80.	7	1.017	0.5476	1.0026	1.0121	0.9470	0.0	0.0	0.194	-4.33	63.0	1.032	1.632
90.	8	1.016	0.5474	0.9977	1.0070	0.9454	0.0	0.0	0.203	-3.83	62.5	1.022	1.622
100.	9	1.010	0.5466	0.9890	0.9775	0.9265	0.0	0.0	0.217	-2.95	61.6	1.005	1.605
110.	10	0.999	0.5424	0.9503	0.9558	0.9202	0.0	0.0	0.226	-2.36	61.1	0.994	0.994
120.	11	0.993	0.5375	0.9603	0.9625	0.9250	0.0	0.0	0.232	-2.01	60.7	0.987	0.987
130.	12	0.997	0.5331	0.9699	0.9690	0.9835	0.0	0.0	0.235	-1.78	60.5	0.983	0.983
140.	13	0.980	0.5290	0.9805	0.9766	0.9942	0.0	0.0	0.236	-1.53	60.2	0.978	0.978
150.	14	0.966	0.5260	0.9885	0.9827	1.0021	0.0	0.0	0.241	-1.32	60.0	0.974	0.974
160.	15	0.985	0.5243	0.9925	0.9854	1.0061	0.0	0.0	0.242	-1.18	59.9	0.971	0.971
170.	16	0.985	0.5233	0.9939	0.9842	1.0081	0.0	0.0	0.245	-1.08	59.6	0.970	0.970
180.	17	0.984	0.5226	0.9946	0.9863	1.0095	0.0	0.0	0.246	-1.01	59.7	0.968	0.968
190.	18	0.983	0.5221	0.9946	0.9866	1.0106	0.0	0.0	0.247	-0.94	59.6	0.967	0.967
200.	19	0.983	0.5216	0.9946	0.9859	1.0115	0.0	0.0	0.247	-0.92	59.6	0.967	0.967
210.	20	0.983	0.5215	0.9944	0.9854	1.0121	0.0	0.0	0.247	-0.90	59.6	0.966	0.966
220.	21	0.983	0.5213	0.9943	0.9851	1.0125	0.0	0.0	0.247	-0.90	59.6	0.966	0.966
230.	22	0.983	0.5213	0.9935	0.9843	1.0127	0.0	0.0	0.247	-0.92	59.6	0.967	0.967
240.	23	0.983	0.5215	0.9926	0.9836	1.0127	0.0	0.0	0.246	-0.98	59.7	0.968	0.968
250.	24	0.984	0.5219	0.9914	0.9827	1.0125	0.0	0.0	0.244	-1.11	59.8	0.970	0.970
260.	25	0.985	0.5224	0.9950	0.9865	1.0135	0.0	0.0	0.238	-1.44	60.1	0.976	0.976
270.	26	0.989	0.5230	1.0011	0.9937	1.0154	0.0	0.0	0.236	-1.92	60.6	0.985	0.985
280.	27	0.994	0.5255	1.0182	1.0117	1.0200	0.0	0.0	0.220	-2.55	61.2	0.997	0.997
290.	28	1.001	0.5279	1.0374	1.0526	1.0245	0.0	0.0	0.212	-3.03	61.7	1.006	1.006
300.	29	1.006	0.5315	1.0359	1.0336	1.0215	0.0	0.0	0.209	-3.34	62.0	1.012	1.012
310.	30	1.009	0.5348	1.0318	1.0320	1.0156	0.0	0.0	0.205	-3.54	62.2	1.016	1.016
320.	31	1.011	0.5382	1.0250	1.0276	1.0072	0.0	0.0	0.203	-3.71	62.4	1.020	1.020
330.	32	1.012	0.5416	1.0182	1.0220	0.9997	0.0	0.0	0.200	-3.88	62.6	1.023	1.023
340.	33	1.013	0.5429	1.0137	1.0198	0.9952	0.0	0.0	0.196	-4.02	62.7	1.026	1.026
350.	34	1.014	0.5442	1.0112	1.0182	0.9928	0.0	0.0	0.197	-4.12	62.8	1.028	1.028
360.	35	1.015	0.5450	1.0100	1.0176	0.9913	0.0	0.0	0.196	-4.20	62.9	1.029	1.029
370.	36	1.015	0.5458	1.0091	1.0172	0.9904	0.0	0.0	0.196	-4.20	62.9	1.029	1.029

STAGE 5 ROTOR

FLOW SWIRL = 22.03DEG PARTICLE SWIRL = 61.0RDEG PSAVG = 14.33PSIA = 91743.PA

PTAVG = 16.73PSIA = 115372.PA TTAVG = 704.5DEG P = 391.4DEG K VELAVG = 605.4FPS = 184.5MPS
 RVELAVG = 634.6FPS = 254.4MPS AXVELAVG = 555.7FPS = 181.6MPS U = 693.FPS = 211.MPS

THETA	SEG NO	VEL	MN	PS	PT	TT	WBL LBM/SEC	WEL KG/SEC	DF	INCIDENCE IN DEG	BETA IN DEG	AXIAL VEL	REL VEL
38.	1	1.032	0.4950	1.0056	1.0176	0.9896	0.0	0.0	0.353	-2.62	46.6	1.032	1.014
42.	2	1.034	0.4957	1.0046	1.0173	0.9890	0.0	0.0	0.352	-2.66	46.7	1.034	1.014
46.	3	1.035	0.4963	1.0039	1.0168	0.9885	0.0	0.0	0.352	-2.69	46.7	1.035	1.015
50.	4	1.035	0.4967	1.0035	1.0166	0.9882	0.0	0.0	0.351	-2.71	46.7	1.035	1.015
54.	5	1.035	0.4964	1.0032	1.0165	0.9880	0.0	0.0	0.351	-2.72	46.7	1.035	1.015
58.	6	1.036	0.4971	1.0021	1.0156	0.9876	0.0	0.0	0.351	-2.73	46.7	1.036	1.015
62.	7	1.034	0.4977	1.0002	1.0137	0.9870	0.0	0.0	0.352	-2.72	46.7	1.035	1.015
66.	8	1.032	0.4965	0.9957	1.0086	0.9854	0.0	0.0	0.354	-2.65	46.6	1.033	1.014
70.	9	1.022	0.4932	0.9687	0.9792	0.9765	0.0	0.0	0.366	-2.28	46.3	1.022	1.009
74.	10	1.003	0.4851	0.9523	0.9575	0.9702	0.0	0.0	0.363	-1.63	45.6	1.003	1.001
78.	11	0.991	0.4776	0.9631	0.9639	0.9750	0.0	0.0	0.391	-1.23	45.2	0.991	0.996
82.	12	0.984	0.4724	0.9727	0.9701	0.9835	0.0	0.0	0.395	-1.00	45.0	0.984	0.993
86.	13	0.966	0.4679	0.9828	0.9774	0.9942	0.0	0.0	0.396	-0.87	44.9	0.966	0.992
90.	14	0.976	0.4636	0.9906	0.9827	1.0021	0.0	0.0	0.398	-0.72	44.7	0.976	0.990
94.	15	0.977	0.4610	0.9946	0.9849	1.0061	0.0	0.0	0.399	-0.59	44.6	0.972	0.988
98.	16	0.970	0.4593	0.9941	0.9853	1.0081	0.0	0.0	0.400	-0.50	44.5	0.970	0.987
102.	17	0.968	0.4580	0.9948	0.9852	1.0095	0.0	0.0	0.401	-0.43	44.4	0.968	0.987
106.	18	0.967	0.4571	0.9949	0.9847	1.0106	0.0	0.0	0.402	-0.38	44.4	0.967	0.986
110.	19	0.965	0.4565	0.9971	0.9844	1.0115	0.0	0.0	0.402	-0.34	44.3	0.965	0.986
114.	20	0.965	0.4560	0.9967	0.9838	1.0121	0.0	0.0	0.402	-0.33	44.3	0.965	0.985
118.	21	0.965	0.4557	0.9966	0.9835	1.0125	0.0	0.0	0.402	-0.32	44.3	0.965	0.985
122.	22	0.965	0.4557	0.9957	0.9827	1.0127	0.0	0.0	0.402	-0.32	44.3	0.965	0.985
126.	23	0.965	0.4559	0.9948	0.9819	1.0127	0.0	0.0	0.402	-0.33	44.3	0.965	0.985
130.	24	0.966	0.4566	0.9935	0.9810	1.0125	0.0	0.0	0.401	-0.37	44.4	0.966	0.986
134.	25	0.969	0.4575	0.9929	0.9849	1.0135	0.0	0.0	0.398	-0.46	44.5	0.969	0.987
138.	26	0.975	0.4604	1.0024	0.9922	1.0154	0.0	0.0	0.391	-0.70	44.7	0.975	0.990
142.	27	0.985	0.4642	1.0184	1.0104	1.0200	0.0	0.0	0.362	-1.04	45.0	0.985	0.994
146.	28	0.998	0.4696	1.0360	1.0313	1.0245	0.0	0.0	0.370	-1.49	45.5	0.998	0.999
150.	29	1.008	0.4751	1.0336	1.0325	1.0215	0.0	0.0	0.363	-1.82	45.6	1.008	1.003
154.	30	1.014	0.4795	1.0295	1.0313	1.0156	0.0	0.0	0.360	-2.02	46.0	1.014	1.006
158.	31	1.018	0.4834	1.0226	1.0272	1.0072	0.0	0.0	0.356	-2.15	46.1	1.018	1.007
162.	32	1.021	0.4868	1.0163	1.0230	0.9997	0.0	0.0	0.357	-2.25	46.3	1.021	1.009
166.	33	1.024	0.4896	1.0118	1.0203	0.9952	0.0	0.0	0.356	-2.36	46.4	1.024	1.010
170.	34	1.027	0.4916	1.0092	1.0190	0.9928	0.0	0.0	0.355	-2.45	46.5	1.027	1.011
174.	35	1.029	0.4929	1.0079	1.0185	0.9913	0.0	0.0	0.355	-2.51	46.5	1.029	1.012
178.	36	1.031	0.4940	1.0070	1.0183	0.9904	0.0	0.0	0.354	-2.57	46.6	1.031	1.013

REPRODUCTION BY THE
 ORIGINAL SOURCE

APPENDIX B (Cont'd)

STATCF

FLOW SWIRL= 22.15DEG PARTICLE SWIRL= 65.500DEG PSAVG= 16.28PSIA = 112237.PA
 PTAVG= 14.87PSIA = 136992.PA TTAVG= 739.7DEG R = 411.0DEG K VELAVG= 701.5FPS = 213.8MPS
 RVELAVG= 649.0FPS = 197.8MPS AXVELAVG= 520.1FPS = 176.8MPS U= 685.FPS = 209.MPS

THETA	SEG	VEL	MN	PS	PT	TT	WBL	WBL	DF	INCIDENCE	ALPHA	AXIAL	REL
	NO						LBM/SEC	KG/SEC		IN DEG	IN DEG	VEL	VEL
32.	1	1.015	0.5537	1.0065	1.0149	0.9902	0.0	0.0	0.322	-1.41	57.3	1.033	1.033
42.	2	1.016	0.5541	1.0058	1.0145	0.9895	0.0	0.0	0.321	-1.45	57.3	1.034	1.034
52.	3	1.016	0.5545	1.0050	1.0140	0.9890	0.0	0.0	0.320	-1.49	57.4	1.035	1.035
62.	4	1.016	0.5546	1.0048	1.0138	0.9887	0.0	0.0	0.320	-1.50	57.4	1.035	1.035
72.	5	1.016	0.5546	1.0048	1.0138	0.9888	0.0	0.0	0.320	-1.51	57.4	1.035	1.035
82.	6	1.016	0.5548	1.0038	1.0129	0.9881	0.0	0.0	0.320	-1.52	57.4	1.035	1.035
92.	7	1.016	0.5548	1.0022	1.0113	0.9875	0.0	0.0	0.320	-1.49	57.4	1.035	1.035
102.	8	1.014	0.5542	0.9988	1.0075	0.9862	0.0	0.0	0.323	-1.36	57.3	1.032	1.032
112.	9	1.005	0.5513	0.9775	0.9839	0.9787	0.0	0.0	0.335	-0.65	56.6	1.016	1.016
122.	10	0.993	0.5458	0.9657	0.9682	0.9732	0.0	0.0	0.354	0.42	55.5	0.993	0.993
132.	11	0.989	0.5425	0.9732	0.9734	0.9761	0.0	0.0	0.362	0.92	55.0	0.982	0.982
142.	12	0.987	0.5395	0.9789	0.9771	0.9822	0.0	0.0	0.366	1.18	54.7	0.977	0.977
152.	13	0.986	0.5364	0.9858	0.9817	0.9914	0.0	0.0	0.367	1.28	54.6	0.975	0.975
162.	14	0.985	0.5337	0.9923	0.9863	0.9998	0.0	0.0	0.368	1.40	54.5	0.972	0.972
172.	15	0.985	0.5323	0.9954	0.9883	1.0048	0.0	0.0	0.370	1.50	54.4	0.970	0.970
182.	16	0.985	0.5315	0.9961	0.9885	1.0072	0.0	0.0	0.371	1.56	54.3	0.968	0.968
192.	17	0.985	0.5309	0.9962	0.9881	1.0087	0.0	0.0	0.372	1.64	54.3	0.967	0.967
202.	18	0.984	0.5304	0.9959	0.9876	1.0098	0.0	0.0	0.372	1.69	54.2	0.966	0.966
212.	19	0.984	0.5300	0.9959	0.9872	1.0107	0.0	0.0	0.373	1.73	54.2	0.965	0.965
222.	20	0.984	0.5299	0.9951	0.9864	1.0113	0.0	0.0	0.373	1.74	54.2	0.965	0.965
232.	21	0.984	0.5297	0.9949	0.9860	1.0118	0.0	0.0	0.373	1.75	54.1	0.965	0.965
242.	22	0.984	0.5298	0.9938	0.9851	1.0120	0.0	0.0	0.373	1.74	54.2	0.965	0.965
252.	23	0.985	0.5300	0.9928	0.9841	1.0120	0.0	0.0	0.373	1.71	54.2	0.966	0.966
262.	24	0.985	0.5305	0.9913	0.9830	1.0118	0.0	0.0	0.372	1.65	54.3	0.967	0.967
272.	25	0.987	0.5312	0.9938	0.9859	1.0128	0.0	0.0	0.369	1.49	54.4	0.970	0.970
282.	26	0.991	0.5332	0.9974	0.9909	1.0143	0.0	0.0	0.362	1.10	54.8	0.979	0.979
292.	27	0.997	0.5354	1.0110	1.0060	1.0186	0.0	0.0	0.353	0.53	55.4	0.991	0.991
302.	28	1.005	0.5385	1.0262	1.0233	1.0229	0.0	0.0	0.341	-0.18	56.1	1.006	1.006
312.	29	1.009	0.5415	1.0253	1.0246	1.0210	0.0	0.0	0.333	-0.63	56.5	1.016	1.016
322.	30	1.012	0.5440	1.0237	1.0249	1.0166	0.0	0.0	0.329	-0.87	56.8	1.021	1.021
332.	31	1.012	0.5467	1.0196	1.0228	1.0094	0.0	0.0	0.328	-0.99	56.9	1.024	1.024
342.	32	1.015	0.5491	1.0148	1.0197	1.0020	0.0	0.0	0.327	-1.07	57.0	1.025	1.025
352.	33	1.014	0.5508	1.0110	1.0172	0.9967	0.0	0.0	0.326	-1.15	57.0	1.027	1.027
362.	34	1.014	0.5520	1.0088	1.0159	0.9937	0.0	0.0	0.324	-1.23	57.1	1.029	1.029
372.	35	1.014	0.5526	1.0082	1.0157	0.9921	0.0	0.0	0.324	-1.26	57.2	1.030	1.030
382.	36	1.015	0.5531	1.0075	1.0155	0.9910	0.0	0.0	0.323	-1.34	57.2	1.031	1.031

STATCF

FLOW SWIRL= 22.740DEG PARTICLE SWIRL= 67.090DEG PSAVG= 17.12PSIA = 118065.PA
 PTAVG= 14.65PSIA = 135507.PA TTAVG= 739.7DEG R = 411.0DEG K VELAVG= 585.6FPS = 178.5MPS
 RVELAVG= 669.4FPS = 265.0MPS AXVELAVG= 584.5FPS = 178.2MPS U= 679.FPS = 207.MPS

THETA	SEG	VEL	MN	PS	PT	TT	WBL	WBL	DF	INCIDENCE	BETA	AXIAL	REL
	NO						LBM/SEC	KG/SEC		IN DEG	IN DEG	VEL	VEL
34.	1	1.027	0.4636	1.0069	1.0160	0.9902	0.007	0.003	0.389	-6.96	43.1	1.027	1.011
44.	2	1.026	0.4641	1.0062	1.0156	0.9895	0.007	0.003	0.389	-6.98	43.1	1.026	1.012
54.	3	1.029	0.4646	1.0054	1.0151	0.9890	0.007	0.003	0.386	-7.00	43.1	1.029	1.012
64.	4	1.029	0.4648	1.0052	1.0150	0.9887	0.007	0.003	0.386	-7.01	43.1	1.029	1.012
74.	5	1.029	0.4650	1.0051	1.0150	0.9885	0.007	0.003	0.388	-7.02	43.1	1.029	1.012
84.	6	1.029	0.4651	1.0041	1.0141	0.9881	0.007	0.003	0.388	-7.02	43.1	1.029	1.012
94.	7	1.029	0.4651	1.0026	1.0126	0.9875	0.007	0.003	0.389	-7.01	43.1	1.029	1.012
104.	8	1.026	0.4648	0.9990	1.0088	0.9862	0.005	0.002	0.390	-6.97	43.1	1.028	1.012
114.	9	1.022	0.4640	0.9753	0.9843	0.9787	-0.006	-0.003	0.397	-6.81	42.9	1.022	1.009
124.	10	1.008	0.4568	0.9612	0.9671	0.9732	-0.016	-0.007	0.410	-6.40	42.5	1.006	1.003
134.	11	0.997	0.4528	0.9696	0.9719	0.9761	-0.016	-0.007	0.418	-6.06	42.2	0.997	0.999
144.	12	0.991	0.4484	0.9750	0.9755	0.9822	-0.016	-0.007	0.421	-5.88	42.0	0.991	0.996
154.	13	0.987	0.4447	0.9829	0.9804	0.9914	-0.014	-0.006	0.423	-5.77	41.9	0.987	0.995
164.	14	0.984	0.4413	0.9894	0.9848	0.9996	-0.013	-0.006	0.424	-5.67	41.8	0.984	0.993
174.	15	0.981	0.4386	0.9930	0.9869	1.0048	-0.012	-0.005	0.425	-5.57	41.7	0.981	0.992
184.	16	0.978	0.4365	0.9944	0.9871	1.0072	-0.011	-0.005	0.426	-5.47	41.6	0.978	0.991
194.	17	0.975	0.4350	0.9951	0.9860	1.0087	-0.010	-0.004	0.426	-5.39	41.5	0.975	0.989
204.	18	0.973	0.4337	0.9953	0.9864	1.0098	-0.008	-0.004	0.426	-5.32	41.4	0.973	0.989
214.	19	0.971	0.4328	0.9956	0.9861	1.0107	-0.008	-0.003	0.430	-5.27	41.4	0.971	0.986
224.	20	0.970	0.4321	0.9953	0.9854	1.0113	-0.008	-0.003	0.431	-5.23	41.3	0.970	0.987
234.	21	0.969	0.4316	0.9953	0.9852	1.0118	-0.008	-0.003	0.431	-5.21	41.3	0.969	0.987
244.	22	0.968	0.4312	0.9947	0.9843	1.0120	-0.005	-0.002	0.432	-5.16	41.3	0.968	0.987
254.	23	0.968	0.4310	0.9941	0.9836	1.0120	-0.004	-0.002	0.432	-5.17	41.3	0.968	0.986
264.	24	0.966	0.4309	0.9932	0.9827	1.0118	-0.007	-0.001	0.432	-5.16	41.2	0.966	0.986
274.	25	0.969	0.4315	0.9942	0.9859	1.0123	-0.001	-0.000	0.430	-5.21	41.3	0.969	0.987
284.	26	0.972	0.4331	1.0005	0.9811	1.0143	0.003	0.002	0.426	-5.34	41.4	0.973	0.989
294.	27	0.985	0.4361	1.0127	1.0062	1.0186	0.007	0.003	0.416	-5.63	41.7	0.983	0.993
304.	28	0.996	0.4416	1.0282	1.0236	1.0229	0.011	0.005	0.405	-6.03	42.1	0.996	0.996
314.	29	1.005	0.4463	1.0288	1.0251	1.0210	0.012	0.005	0.399	-6.31	42.4	1.005	1.002
324.	30	1.011	0.4500	1.0249	1.0255	1.0166	0.012	0.005	0.395	-6.48	42.6	1.011	1.005
334.	31	1.015	0.4533	1.0207	1.0234	1.0094	0.011	0.005	0.393	-6.59	42.7	1.015	1.006
344.	32	1.017	0.4562	1.0159	1.0204	1.0020	0.009	0.004	0.393	-6.67	42.6	1.017	1.007
354.	33	1.020	0.4587	1.0120	1.0180	0.9967	0.008	0.004	0.392	-6.75	42.8	1.020	1.008
364.	34	1.022	0.4605	1.0098	1.0168	0.9937	0.008	0.003	0.391	-6.82	42.9	1.022	1.009
374.	35	1.024	0.4617	1.0088	1.0167	0.9921	0.007	0.003	0.390	-6.87	43.0	1.024	1.010
384.	36	1.026	0.4626	1.0080	1.0165	0.9910	0.007	0.003	0.390	-6.92	43.0	1.026	1.011

APPENDIX B (Cont'd)

STAGE

FLOW SWIRL= 20.12DEG PARTICLE SWIRL= 70.37DEG PS AVG= 19.64PSIA = 135409.PA
 PTAVG= 21.00PSIA = 159000.PA TTAVG= 776.8DEG R = 431.6DEG K VELAVG= 647.1FPS = 197.2MPS
 PVELAVG= 451.9FPS = 142.7MPS AXVELAVG= 555.1FPS = 169.2MPS U= 674.FPS = 205.MPS

THETA	SEG	VEL	MN	PS	PT	TT	WBL	WBL	DF	INCIDENCE	BETA	AXIAL	REL
	NO						LBM/SEC	KG/SEC		IN DEG	IN DEG	VEL	VEL
35.	1	1.014	0.4956	1.0067	1.0128	0.9912	0.0	0.0	0.225	-9.53	60.5	1.02P	1.028
47.	2	1.014	0.4952	1.0063	1.0126	0.9896	0.0	0.0	0.225	-9.55	60.6	1.02P	1.029
57.	3	1.014	0.4954	1.0057	1.0121	0.9891	0.0	0.0	0.225	-9.57	60.6	1.02P	1.029
65.	4	1.014	0.4955	1.0057	1.0121	0.9884	0.0	0.0	0.224	-9.58	60.6	1.02P	1.029
75.	5	1.014	0.4956	1.0057	1.0122	0.9886	0.0	0.0	0.224	-9.59	60.6	1.030	1.030
85.	6	1.014	0.4956	1.0049	1.0114	0.9882	0.0	0.0	0.224	-9.59	60.6	1.029	1.029
95.	7	1.013	0.4951	1.0036	1.0101	0.9877	0.0	0.0	0.225	-9.56	60.6	1.029	1.029
105.	8	1.017	0.4951	1.0008	1.0071	0.9866	0.0	0.0	0.224	-9.47	60.5	1.027	1.027
115.	9	1.017	0.4945	0.9957	1.0054	0.9850	0.0	0.0	0.233	-9.05	60.0	1.019	1.019
125.	10	1.017	0.4902	0.9724	0.9752	0.9756	0.0	0.0	0.246	-6.11	59.1	1.000	1.000
135.	11	0.962	0.4873	0.9797	0.9866	0.9777	0.0	0.0	0.257	-7.54	58.5	0.989	0.989
145.	12	0.960	0.4850	0.9674	0.9821	0.9814	0.0	0.0	0.260	-7.29	58.3	0.984	0.984
155.	13	0.960	0.4827	0.9677	0.9848	0.9805	0.0	0.0	0.262	-7.16	58.2	0.982	0.982
175.	14	0.948	0.4803	0.9616	0.9851	0.9877	0.0	0.0	0.263	-7.07	58.1	0.980	0.980
175.	15	0.948	0.4787	0.9946	0.9901	1.0035	0.0	0.0	0.264	-6.95	58.0	0.978	0.978
185.	16	0.948	0.4776	0.9957	0.9905	1.0067	0.0	0.0	0.266	-6.83	57.8	0.976	0.976
195.	17	0.947	0.4769	0.9960	0.9903	1.0084	0.0	0.0	0.267	-6.72	57.7	0.973	0.973
205.	18	0.944	0.4763	0.9958	0.9897	1.0095	0.0	0.0	0.268	-6.63	57.6	0.972	0.972
215.	19	0.944	0.4758	0.9957	0.9893	1.0105	0.0	0.0	0.268	-6.54	57.5	0.970	0.970
235.	20	0.945	0.4754	0.9952	0.9886	1.0111	0.0	0.0	0.270	-6.49	57.5	0.969	0.969
245.	21	0.945	0.4752	0.9949	0.9882	1.0116	0.0	0.0	0.271	-6.45	57.5	0.968	0.968
265.	22	0.945	0.4750	0.9942	0.9874	1.0118	0.0	0.0	0.271	-6.41	57.4	0.966	0.966
265.	23	0.945	0.4750	0.9935	0.9866	1.0119	0.0	0.0	0.271	-6.39	57.4	0.967	0.967
275.	24	0.945	0.4750	0.9925	0.9858	1.0118	0.0	0.0	0.271	-6.39	57.4	0.967	0.967
275.	25	0.945	0.4750	0.9945	0.9860	1.0126	0.0	0.0	0.270	-6.52	57.5	0.970	0.970
295.	26	0.949	0.4765	0.9973	0.9915	1.0139	0.0	0.0	0.269	-6.61	57.8	0.975	0.975
295.	27	0.949	0.4793	1.0071	1.0028	1.0174	0.0	0.0	0.256	-7.46	58.5	0.988	0.988
305.	28	1.004	0.4824	1.0164	1.0162	1.0211	0.0	0.0	0.244	-6.26	59.3	1.003	1.003
315.	29	1.008	0.4847	1.0185	1.0177	1.0200	0.0	0.0	0.236	-6.72	59.7	1.012	1.012
325.	30	1.011	0.4866	1.0188	1.0193	1.0187	0.0	0.0	0.233	-6.98	60.0	1.017	1.017
345.	31	1.011	0.4887	1.0167	1.0186	1.0107	0.0	0.0	0.231	-9.12	60.1	1.020	1.020
345.	32	1.011	0.4907	1.0135	1.0167	1.0037	0.0	0.0	0.230	-9.20	60.2	1.022	1.022
355.	33	1.017	0.4923	1.0104	1.0147	0.9979	0.0	0.0	0.229	-9.28	60.3	1.023	1.023
37.	34	1.013	0.4934	1.0085	1.0135	0.9944	0.0	0.0	0.226	-9.35	60.4	1.025	1.025
37.	35	1.013	0.4940	1.0081	1.0136	0.9925	0.0	0.0	0.227	-9.41	60.4	1.026	1.026
23.	36	1.013	0.4945	1.0075	1.0134	0.9912	0.0	0.0	0.226	-9.47	60.5	1.027	1.027

STAGE 7
 ROTOR

FLOW SWIRL= 25.20DEG PARTICLE SWIRL= 72.46DEG PS AVG= 20.41PSIA = 140708.PA
 PTAVG= 23.06PSIA = 156990.PA TTAVG= 776.8DEG R = 431.6DEG K VELAVG= 565.6FPS = 172.4MPS
 RVELAVG= 797.9FPS = 243.2MPS AXVELAVG= 556.9FPS = 169.8MPS U= 670.FPS = 204.MPS

THETA	SEG	VEL	MN	PS	PT	TT	WBL	WBL	DF	INCIDENCE	BETA	AXIAL	REL
	NO						LBM/SEC	KG/SEC		IN DEG	IN DEG	VEL	VEL
35.	1	1.029	0.4368	1.0059	1.0143	0.9963	0.0	0.0	0.323	-5.33	45.7	1.029	1.011
47.	2	1.029	0.4372	1.0055	1.0141	0.9896	0.0	0.0	0.322	-5.35	45.3	1.029	1.012
55.	3	1.030	0.4375	1.0049	1.0137	0.9891	0.0	0.0	0.322	-5.36	45.3	1.030	1.012
65.	4	1.030	0.4377	1.0048	1.0137	0.9886	0.0	0.0	0.322	-5.37	45.3	1.030	1.012
75.	5	1.030	0.4378	1.0048	1.0138	0.9886	0.0	0.0	0.322	-5.38	45.3	1.030	1.012
85.	6	1.030	0.4376	1.0041	1.0131	0.9882	0.0	0.0	0.322	-5.37	45.3	1.030	1.012
95.	7	1.029	0.4376	1.0029	1.0118	0.9877	0.0	0.0	0.323	-5.35	45.3	1.029	1.012
105.	8	1.027	0.4370	1.0003	1.0088	0.9866	0.0	0.0	0.325	-5.28	45.2	1.027	1.011
115.	9	1.018	0.4344	0.9814	0.9882	0.9800	0.0	0.0	0.333	-4.98	44.9	1.018	1.007
125.	10	0.998	0.4267	0.9744	0.9768	0.9756	0.0	0.0	0.349	-4.32	44.2	0.998	0.999
135.	11	0.987	0.4212	0.9870	0.9814	0.9777	0.0	0.0	0.355	-3.94	43.8	0.987	0.995
145.	12	0.962	0.4183	0.9846	0.9823	0.9819	0.0	0.0	0.357	-3.78	43.7	0.982	0.993
155.	13	0.960	0.4158	0.9885	0.9848	0.9895	0.0	0.0	0.359	-3.72	43.6	0.980	0.992
165.	14	0.929	0.4134	0.9929	0.9879	0.9977	0.0	0.0	0.359	-3.67	43.6	0.979	0.992
175.	15	0.977	0.4114	0.9957	0.9895	1.0035	0.0	0.0	0.360	-3.60	43.5	0.977	0.991
185.	16	0.975	0.4098	0.9965	0.9895	1.0067	0.0	0.0	0.360	-3.53	43.4	0.975	0.990
195.	17	0.973	0.4087	0.9965	0.9889	1.0094	0.0	0.0	0.361	-3.47	43.4	0.973	0.989
205.	18	0.971	0.4077	0.9962	0.9880	1.0095	0.0	0.0	0.362	-3.41	43.3	0.971	0.989
215.	19	0.970	0.4069	0.9960	0.9874	1.0125	0.0	0.0	0.362	-3.36	43.3	0.970	0.988
225.	20	0.969	0.4064	0.9953	0.9864	1.0111	0.0	0.0	0.363	-3.33	43.2	0.969	0.988
235.	21	0.968	0.4060	0.9950	0.9859	1.0116	0.0	0.0	0.363	-3.31	43.2	0.968	0.987
245.	22	0.968	0.4056	0.9943	0.9850	1.0118	0.0	0.0	0.363	-3.28	43.2	0.968	0.987
255.	23	0.967	0.4055	0.9935	0.9841	1.0119	0.0	0.0	0.364	-3.27	43.2	0.967	0.987
265.	24	0.967	0.4055	0.9925	0.9831	1.0118	0.0	0.0	0.363	-3.27	43.2	0.967	0.987
275.	25	0.970	0.4064	0.9946	0.9857	1.0126	0.0	0.0	0.361	-3.35	43.3	0.970	0.988
285.	26	0.975	0.4084	0.9977	0.9898	1.0139	0.0	0.0	0.357	-3.54	43.4	0.975	0.990
295.	27	0.988	0.4132	1.0071	1.0018	1.0174	0.0	0.0	0.347	-3.97	43.9	0.988	0.995
305.	28	1.004	0.4193	1.0179	1.0160	1.0211	0.0	0.0	0.336	-4.56	44.4	1.004	1.001
315.	29	1.013	0.4236	1.0173	1.0179	1.0200	0.0	0.0	0.330	-4.82	44.7	1.013	1.005
325.	30	1.018	0.4265	1.0174	1.0197	1.0167	0.0	0.0	0.327	-4.99	44.9	1.016	1.007
325.	31	1.021	0.4290	1.0154	1.0192	1.0107	0.0	0.0	0.325	-5.08	45.0	1.021	1.006
345.	32	1.025	0.4312	1.0125	1.0175	1.0037	0.0	0.0	0.324	-5.13	45.0	1.023	1.009
355.	33	1.024	0.4330	1.0095	1.0157	0.9979	0.0	0.0	0.324	-5.17	45.1	1.024	1.010
37.	34	1.025	0.4344	1.0077	1.0147	0.9944	0.0	0.0	0.324	-5.22	45.1	1.025	1.010
37.	35	1.026	0.4353	1.0074	1.0149	0.9925	0.0	0.0	0.324	-5.25	45.2	1.026	1.010
23.	36	1.028	0.4361	1.0068	1.0148	0.9912	0.0	0.0	0.323	-5.30	45.2	1.028	1.011

APPENDIX B (Cont'd)

STACF

FLOW SWIRL = 25.17DEG				PARTICLE SWIRL = 76.65DEG				PSAVG = 22.30PSIA = 153754.PA					
PTAVG = 26.20PSIA = 180654.PA				TTAVG = R12.7DEG R = 451.5DEG K				VELAVG = 663.2FPS = 202.1MPS					
RVFLAVG = 623.3FPS = 190.0MPS				AXVELAVG = 549.4FPS = 167.5MPS				J = 666.FPS = 203.MPS					
THETA	SEG	VEL	MN	PS	PT	TT	WBL	WBL	DF	INCIDENCE	ALPHA	AXIAL	REL
	NO						LBM/SEC	KG/SEC		IN DEG	IN DEG	VEL	VEL
35.	1	1.013	0.4958	1.0070	1.0128	0.9906	0.0	0.0	0.256	-10.99	57.3	1.028	1.028
45.	2	1.013	0.4959	1.0068	1.0128	0.9899	0.0	0.0	0.256	-11.00	57.3	1.029	1.029
55.	3	1.013	0.4961	1.0063	1.0124	0.9894	0.0	0.0	0.256	-11.02	57.3	1.029	1.029
65.	4	1.013	0.4962	1.0063	1.0125	0.9890	0.0	0.0	0.256	-11.02	57.3	1.029	1.029
75.	5	1.013	0.4963	1.0064	1.0125	0.9888	0.0	0.0	0.255	-11.03	57.3	1.029	1.029
85.	6	1.013	0.4963	1.0057	1.0119	0.9884	0.0	0.0	0.256	-11.02	57.3	1.029	1.029
95.	7	1.012	0.4962	1.0048	1.0110	0.9880	0.0	0.0	0.256	-10.96	57.3	1.028	1.028
105.	8	1.011	0.4957	1.0030	1.0088	0.9871	0.0	0.0	0.258	-10.86	57.2	1.026	1.026
115.	9	1.005	0.4940	0.9873	0.9919	0.9816	0.0	0.0	0.268	-10.31	56.6	1.014	1.014
125.	10	0.994	0.4892	0.9837	0.9852	0.9786	0.0	0.0	0.266	-9.29	55.6	0.992	0.992
135.	11	0.990	0.4871	0.9883	0.9884	0.9795	0.0	0.0	0.293	-8.82	55.1	0.963	0.963
145.	12	0.989	0.4858	0.9879	0.9872	0.9818	0.0	0.0	0.296	-8.64	54.9	0.979	0.979
155.	13	0.988	0.4838	0.9898	0.9879	0.9876	0.0	0.0	0.297	-8.55	54.8	0.977	0.977
165.	14	0.988	0.4817	0.9931	0.9898	0.9952	0.0	0.0	0.297	-8.56	54.6	0.976	0.976
175.	15	0.986	0.4802	0.9953	0.9910	1.0016	0.0	0.0	0.298	-8.47	54.8	0.975	0.975
185.	16	0.986	0.4793	0.9957	0.9908	1.0055	0.0	0.0	0.298	-8.42	54.7	0.974	0.974
195.	17	0.988	0.4787	0.9954	0.9901	1.0077	0.0	0.0	0.299	-8.36	54.7	0.973	0.973
205.	18	0.987	0.4782	0.9947	0.9891	1.0090	0.0	0.0	0.300	-8.30	54.6	0.972	0.972
215.	19	0.987	0.4777	0.9942	0.9883	1.0100	0.0	0.0	0.301	-8.25	54.5	0.971	0.971
225.	20	0.987	0.4775	0.9933	0.9872	1.0106	0.0	0.0	0.301	-8.21	54.5	0.970	0.970
235.	21	0.987	0.4773	0.9928	0.9866	1.0112	0.0	0.0	0.302	-8.19	54.5	0.970	0.970
245.	22	0.986	0.4771	0.9920	0.9857	1.0115	0.0	0.0	0.302	-8.17	54.5	0.969	0.969
255.	23	0.986	0.4771	0.9911	0.9848	1.0116	0.0	0.0	0.302	-8.15	54.5	0.969	0.969
265.	24	0.987	0.4772	0.9900	0.9837	1.0115	0.0	0.0	0.302	-8.16	54.5	0.969	0.969
275.	25	0.988	0.4778	0.9915	0.9856	1.0122	0.0	0.0	0.300	-8.16	54.5	0.972	0.972
285.	26	0.991	0.4789	0.9941	0.9889	1.0132	0.0	0.0	0.295	-8.57	54.9	0.978	0.978
295.	27	0.997	0.4816	1.0022	0.9966	1.0167	0.0	0.0	0.285	-9.23	55.5	0.991	0.991
305.	28	1.005	0.4848	1.0117	1.0102	1.0194	0.0	0.0	0.271	-10.03	56.3	1.006	1.006
315.	29	1.009	0.4866	1.0130	1.0127	1.0190	0.0	0.0	0.264	-10.43	56.7	1.016	1.016
325.	30	1.011	0.4881	1.0149	1.0156	1.0169	0.0	0.0	0.260	-10.65	57.0	1.021	1.021
335.	31	1.012	0.4900	1.0143	1.0162	1.0170	0.0	0.0	0.256	-10.76	57.1	1.024	1.024
345.	32	1.012	0.4917	1.0124	1.0156	1.0057	0.0	0.0	0.258	-10.83	57.1	1.025	1.025
355.	33	1.012	0.4932	1.0101	1.0142	0.9997	0.0	0.0	0.258	-10.85	57.1	1.025	1.025
5.	34	1.012	0.4942	1.0086	1.0134	0.9955	0.0	0.0	0.258	-10.67	57.2	1.026	1.026
15.	35	1.012	0.4947	1.0085	1.0136	0.9932	0.0	0.0	0.258	-10.69	57.2	1.026	1.026
25.	36	1.013	0.4953	1.0078	1.0133	0.9916	0.0	0.0	0.257	-10.95	57.2	1.027	1.027

STACF RPTCR

FLOW SWIRL = 27.11DEG				PARTICLE SWIRL = 78.59DEG				PSAVG = 23.57PSIA = 162462.PA					
PTAVG = 26.57PSIA = 183195.PA				TTAVG = R12.7DEG R = 451.5DEG K				VELAVG = 573.7FPS = 174.9MPS					
RVFLAVG = 709.7FPS = 243.7MPS				AXVELAVG = 566.2FPS = 172.6MPS				J = 573.FPS = 200.MPS					
THETA	SEG	VEL	MN	PS	PT	TT	WBL	WBL	DF	INCIDENCE	BETA	AXIAL	REL
	NO						LBM/SEC	KG/SEC		IN DEG	IN DEG	VEL	VEL
37.	1	1.017	0.4283	1.0091	1.0146	0.9966	0.010	0.005	0.356	-5.86	45.7	1.017	1.007
47.	2	1.018	0.4285	1.0090	1.0146	0.9969	0.010	0.005	0.356	-5.87	45.7	1.018	1.007
57.	3	1.018	0.4287	1.0085	1.0142	0.9894	0.010	0.005	0.356	-5.87	45.7	1.018	1.007
67.	4	1.018	0.4288	1.0086	1.0143	0.9890	0.010	0.005	0.356	-5.87	45.7	1.018	1.007
77.	5	1.018	0.4289	1.0086	1.0144	0.9888	0.010	0.005	0.356	-5.87	45.7	1.018	1.008
87.	6	1.018	0.4289	1.0080	1.0138	0.9884	0.010	0.005	0.356	-5.87	45.7	1.018	1.007
97.	7	1.017	0.4288	1.0071	1.0129	0.9880	0.010	0.004	0.357	-5.86	45.7	1.018	1.007
107.	8	1.016	0.4286	1.0052	1.0108	0.9871	0.008	0.003	0.358	-5.82	45.6	1.016	1.007
117.	9	1.006	0.4260	0.9900	0.9941	0.9816	0.003	0.002	0.367	-5.54	45.3	1.008	1.002
127.	10	0.999	0.4229	0.9834	0.9857	0.9786	-0.010	-0.005	0.374	-5.25	45.1	0.999	1.000
137.	11	0.995	0.4210	0.9861	0.9874	0.9795	-0.015	-0.007	0.376	-5.12	44.9	0.995	0.998
147.	12	0.992	0.4193	0.9854	0.9857	0.9818	-0.016	-0.007	0.379	-5.03	44.8	0.992	0.997
157.	13	0.991	0.4175	0.9869	0.9862	0.9876	-0.016	-0.007	0.381	-4.99	44.8	0.991	0.996
167.	14	0.991	0.4157	0.9897	0.9880	0.9952	-0.016	-0.007	0.381	-4.98	44.8	0.991	0.996
177.	15	0.990	0.4141	0.9916	0.9890	1.0016	-0.015	-0.007	0.381	-4.95	44.8	0.990	0.996
187.	16	0.989	0.4127	0.9921	0.9887	1.0055	-0.015	-0.007	0.381	-4.91	44.7	0.989	0.995
197.	17	0.987	0.4116	0.9919	0.9879	1.0077	-0.014	-0.006	0.382	-4.85	44.7	0.987	0.995
207.	18	0.985	0.4105	0.9915	0.9869	1.0090	-0.013	-0.006	0.383	-4.79	44.6	0.985	0.994
217.	19	0.984	0.4096	0.9913	0.9861	1.0100	-0.013	-0.006	0.384	-4.73	44.5	0.984	0.993
227.	20	0.982	0.4087	0.9907	0.9851	1.0106	-0.012	-0.005	0.385	-4.68	44.5	0.982	0.992
237.	21	0.981	0.4080	0.9906	0.9846	1.0112	-0.011	-0.005	0.386	-4.63	44.4	0.981	0.992
247.	22	0.979	0.4074	0.9901	0.9837	1.0115	-0.010	-0.004	0.387	-4.58	44.4	0.979	0.991
257.	23	0.978	0.4068	0.9897	0.9830	1.0116	-0.009	-0.004	0.388	-4.54	44.3	0.978	0.991
267.	24	0.977	0.4062	0.9891	0.9821	1.0115	-0.007	-0.003	0.389	-4.49	44.3	0.977	0.990
277.	25	0.977	0.4064	0.9913	0.9844	1.0122	-0.005	-0.002	0.388	-4.52	44.3	0.977	0.991
287.	26	0.980	0.4074	0.9947	0.9883	1.0132	-0.003	-0.001	0.385	-4.62	44.4	0.980	0.992
297.	27	0.988	0.4104	1.0038	0.9900	1.0162	0.002	0.001	0.378	-4.89	44.7	0.988	0.995
307.	28	0.999	0.4144	1.0132	1.0106	1.0194	0.010	0.005	0.368	-5.26	45.1	0.999	1.000
317.	29	1.006	0.4173	1.0143	1.0134	1.0190	0.012	0.006	0.363	-5.48	45.3	1.006	1.002
327.	30	1.010	0.4196	1.0161	1.0164	1.0169	0.013	0.006	0.360	-5.62	45.4	1.010	1.004
337.	31	1.013	0.4216	1.0156	1.0171	1.0120	0.013	0.006	0.358	-5.70	45.5	1.013	1.005
347.	32	1.014	0.4234	1.0140	1.0166	1.0057	0.012	0.006	0.357	-5.74	45.5	1.014	1.006
357.	33	1.015	0.4251	1.0119	1.0155	0.9957	0.011	0.005	0.356	-5.76	45.6	1.015	1.006
7.	34	1.015	0.4263	1.0105	1.0148	0.9955	0.010	0.005	0.357	-5.79	45.6	1.015	1.006
17.	35	1.016	0.4271	1.0105	1.0153	0.9932	0.010	0.004	0.357	-5.81	45.6	1.016	1.007
27.	36	1.017	0.4279	1.0098	1.0150	0.9916	0.010	0.004	0.356	-5.85	45.6	1.017	1.007

APPENDIX B (Cont'd)

STATOP

FLOW SWIRL= 27.57DEG PARTICLE SWIRL= 84.08DEG PSAVG= 25.61PSIA = 176585.PA
 PTAVG= 30.61PSIA = 211065.PA TTAVG= 843.9DEG R = 468.9DFG K VELAVG= 710.0FPS = 216.4MPS
 RVELAVG= 611.1FPS = 186.3MPS AXVELAVG= 568.2FPS = 173.2MPS U= 650.FPS = 198.MPS

THETA	SEC NO	VEL	MN	PS	PT	TT	WBL LBM/SEC	WBL KG/SEC	DF	INCIDENCE IN DEG	ALPHA IN DEG	AXIAL VEL	REL VEL
3F.	1	1.010	0.5209	1.0060	1.0115	0.9905	0.0	0.0	0.233	-14.66	54.1	1.022	1.022
4B.	2	1.010	0.5211	1.0060	1.0115	0.9898	0.0	0.0	0.233	-14.66	54.1	1.022	1.022
5P.	3	1.010	0.5212	1.0056	1.0113	0.9891	0.0	0.0	0.233	-14.66	54.1	1.022	1.022
6P.	4	1.01C	0.5213	1.0057	1.0114	0.9888	0.0	0.0	0.233	-14.66	54.1	1.021	1.021
7E.	5	1.010	0.5214	1.0057	1.0115	0.9885	0.0	0.0	0.233	-14.67	54.1	1.022	1.022
8F.	6	1.010	0.5214	1.0053	1.0110	0.9881	0.0	0.0	0.233	-14.65	54.1	1.021	1.021
9E.	7	1.009	0.5213	1.0046	1.0103	0.9877	0.0	0.0	0.234	-14.63	54.0	1.021	1.021
10E.	8	1.009	0.5211	1.0032	1.0088	0.9870	0.0	0.0	0.235	-14.57	54.0	1.019	1.019
11B.	9	1.002	0.5185	0.9933	0.9971	0.9830	0.0	0.0	0.247	-14.04	53.4	1.007	1.007
12E.	10	0.997	0.5165	0.9891	0.9915	0.9805	0.0	0.0	0.257	-13.59	53.0	0.996	0.996
13B.	11	0.995	0.5156	0.9910	0.9928	0.9807	0.0	0.0	0.260	-13.42	52.8	0.992	0.992
14E.	12	0.993	0.5141	0.9902	0.9910	0.9818	0.0	0.0	0.264	-13.25	52.6	0.988	0.988
15E.	12	0.992	0.5122	0.9908	0.9903	0.9859	0.0	0.0	0.266	-13.15	52.6	0.986	0.986
16E.	14	0.991	0.5103	0.9925	0.9907	0.9925	0.0	0.0	0.266	-13.14	52.5	0.985	0.985
17E.	15	0.992	0.5087	0.9939	0.9909	0.9992	0.0	0.0	0.266	-13.14	52.5	0.985	0.985
18E.	16	0.992	0.5075	0.9944	0.9907	1.0040	0.0	0.0	0.266	-13.11	52.5	0.985	0.985
19B.	17	0.992	0.5067	0.9945	0.9902	1.0070	0.0	0.0	0.267	-13.06	52.5	0.983	0.983
20E.	18	0.991	0.5059	0.9944	0.9896	1.0087	0.0	0.0	0.268	-12.98	52.4	0.981	0.981
21E.	19	0.990	0.5052	0.9944	0.9891	1.0099	0.0	0.0	0.270	-12.90	52.3	0.980	0.980
22E.	20	0.990	0.5046	0.9941	0.9883	1.0107	0.0	0.0	0.271	-12.83	52.2	0.978	0.978
23E.	21	0.989	0.5041	0.9941	0.9880	1.0114	0.0	0.0	0.273	-12.76	52.2	0.976	0.976
24E.	22	0.988	0.5037	0.9938	0.9875	1.0116	0.0	0.0	0.274	-12.70	52.1	0.975	0.975
25E.	22	0.988	0.5033	0.9936	0.9870	1.0121	0.0	0.0	0.275	-12.63	52.0	0.973	0.973
26E.	24	0.987	0.5030	0.9933	0.9865	1.0121	0.0	0.0	0.277	-12.57	52.0	0.972	0.972
27E.	25	0.988	0.5033	0.9947	0.9881	1.0127	0.0	0.0	0.275	-12.63	52.0	0.973	0.973
28E.	26	0.990	0.5043	0.9966	0.9906	1.0135	0.0	0.0	0.272	-12.61	52.2	0.977	0.977
29E.	27	0.996	0.5068	1.0020	0.9976	1.0156	0.0	0.0	0.262	-13.29	52.7	0.989	0.989
30E.	28	1.003	0.5097	1.0077	1.0053	1.0181	0.0	0.0	0.250	-13.88	53.3	1.003	1.003
31E.	29	1.006	0.5114	1.0087	1.0074	1.0181	0.0	0.0	0.243	-14.19	53.6	1.010	1.010
32B.	30	1.008	0.5131	1.0105	1.0104	1.0168	0.0	0.0	0.236	-14.42	53.8	1.016	1.016
33E.	31	1.010	0.5149	1.0107	1.0119	1.0131	0.0	0.0	0.236	-14.54	53.9	1.019	1.019
34E.	32	1.011	0.5167	1.0100	1.0125	1.0076	0.0	0.0	0.235	-14.60	54.0	1.020	1.020
35E.	32	1.011	0.5184	1.0084	1.0120	1.0016	0.0	0.0	0.234	-14.62	54.0	1.021	1.021
36E.	34	1.010	0.5194	1.0073	1.0117	0.9967	0.0	0.0	0.234	-14.62	54.0	1.021	1.021
37E.	35	1.010	0.5200	1.0074	1.0122	0.9937	0.0	0.0	0.234	-14.62	54.0	1.021	1.021
38E.	36	1.010	0.5207	1.0065	1.0117	0.9917	0.0	0.0	0.233	-14.66	54.1	1.022	1.022

STAGE ROTOP

FLOW SWIRL= 30.24DEG PARTICLE SWIRL= 86.85DEG PSAVG= 24.36PSIA = 161730.PA
 PTAVG= 30.07PSIA = 207350.PA TTAVG= 843.9DEG R = 468.9DEG K VELAVG= 612.3FPS = 186.6MPS
 RVELAVG= 720.2FPS = 222.6MPS AXVELAVG= 578.4FPS = 176.3MPS U= 646.FPS = 197.MPS

THETA	SEC NO	VEL	MN	PS	PT	TT	WBL LBM/SEC	WBL KG/SEC	DF	INCIDENCE IN DEG	BETA IN DEG	AXIAL VEL	REL VEL
4C.	1	1.025	0.4529	1.0024	1.0104	0.9905	0.0	0.0	0.250	-9.48	53.4	1.025	1.011
5C.	2	1.025	0.4532	1.0023	1.0104	0.9898	0.0	0.0	0.250	-9.48	53.4	1.025	1.011
6C.	3	1.025	0.4533	1.0020	1.0102	0.9891	0.0	0.0	0.250	-9.48	53.4	1.025	1.011
7C.	4	1.025	0.4533	1.0021	1.0103	0.9888	0.0	0.0	0.250	-9.48	53.4	1.025	1.011
8C.	5	1.025	0.4535	1.0020	1.0103	0.9885	0.0	0.0	0.250	-9.49	53.4	1.025	1.011
9C.	6	1.024	0.4534	1.0017	1.0099	0.9881	0.0	0.0	0.250	-9.47	53.4	1.024	1.011
10C.	7	1.024	0.4532	1.0012	1.0093	0.9877	0.0	0.0	0.251	-9.44	53.3	1.024	1.011
11C.	8	1.022	0.4525	1.0001	1.0078	0.9870	0.0	0.0	0.252	-9.38	53.3	1.022	1.010
12C.	9	1.007	0.4465	0.9930	0.9970	0.9830	0.0	0.0	0.264	-8.78	52.7	1.007	1.003
13C.	10	0.994	0.4412	0.9910	0.9919	0.9805	0.0	0.0	0.271	-8.26	52.2	0.994	0.997
14C.	11	0.990	0.4391	0.9935	0.9932	0.9807	0.0	0.0	0.272	-8.68	52.0	0.990	0.995
15C.	12	0.995	0.4367	0.9932	0.9915	0.9818	0.0	0.0	0.275	-7.90	51.8	0.985	0.993
16C.	13	0.983	0.4348	0.9939	0.9911	0.9859	0.0	0.0	0.277	-7.80	51.7	0.983	0.992
17C.	14	0.983	0.4332	0.9955	0.9917	0.9925	0.0	0.0	0.278	-7.79	51.7	0.983	0.992
18C.	15	0.983	0.4318	0.9966	0.9920	0.9902	0.0	0.0	0.278	-7.80	51.7	0.983	0.992
19C.	16	0.982	0.4305	0.9971	0.9917	1.0040	0.0	0.0	0.277	-7.78	51.7	0.982	0.992
20C.	17	0.981	0.4293	0.9972	0.9912	1.0070	0.0	0.0	0.277	-7.73	51.6	0.981	0.991
21C.	18	0.979	0.4280	0.9973	0.9905	1.0087	0.0	0.0	0.276	-7.64	51.5	0.979	0.990
22C.	19	0.977	0.4269	0.9975	0.9900	1.0069	0.0	0.0	0.279	-7.56	51.5	0.977	0.989
23C.	20	0.975	0.4259	0.9973	0.9892	1.0107	0.0	0.0	0.280	-7.49	51.4	0.975	0.989
24C.	21	0.973	0.4256	0.9974	0.9889	1.0114	0.0	0.0	0.281	-7.42	51.3	0.973	0.988
25C.	22	0.972	0.4242	0.9974	0.9884	1.0118	0.0	0.0	0.281	-7.35	51.3	0.972	0.987
26C.	23	0.970	0.4234	0.9973	0.9879	1.0121	0.0	0.0	0.282	-7.29	51.2	0.970	0.986
27C.	24	0.969	0.4226	0.9972	0.9873	1.0121	0.0	0.0	0.283	-7.22	51.1	0.969	0.986
28C.	25	0.970	0.4232	0.9984	0.9869	1.0127	0.0	0.0	0.282	-7.28	51.2	0.970	0.986
29C.	26	0.975	0.4251	0.9998	0.9913	1.0135	0.0	0.0	0.278	-7.47	51.4	0.975	0.988
30C.	27	0.987	0.4302	1.0039	0.9983	1.0156	0.0	0.0	0.270	-7.97	51.9	0.987	0.994
31C.	28	1.003	0.4368	1.0074	1.0056	1.0181	0.0	0.0	0.260	-8.61	52.5	1.003	1.001
32C.	29	1.012	0.4409	1.0070	1.0075	1.0181	0.0	0.0	0.255	-8.96	52.9	1.012	1.005
33C.	30	1.018	0.4439	1.0078	1.0102	1.0166	0.0	0.0	0.251	-9.21	53.1	1.018	1.008
34C.	31	1.021	0.4463	1.0075	1.0113	1.0131	0.0	0.0	0.248	-9.35	53.3	1.021	1.010
35C.	32	1.023	0.4482	1.0066	1.0117	1.0076	0.0	0.0	0.247	-9.41	53.3	1.023	1.011
36C.	33	1.024	0.4499	1.0049	1.0110	1.0016	0.0	0.0	0.247	-9.44	53.3	1.024	1.011
37C.	34	1.024	0.4510	1.0038	1.0106	0.9967	0.0	0.0	0.248	-9.44	53.3	1.024	1.011
38C.	35	1.024	0.4517	1.0039	1.0111	0.9937	0.0	0.0	0.249	-9.44	53.3	1.024	1.011
39C.	36	1.025	0.4527	1.0028	1.0106	0.9917	0.0	0.0	0.249	-9.48	53.4	1.025	1.011

STATOR

FLOW SWIRL= 34.29DEG PARTICLE SWIRL= 96.21DEG PSAVG= 29.73PSIA = 204960.PA
 PTAVG= 52.53PSIA = 244996.PA TTAVG= 866.2DEG R = 492.40EG K VELAVG= 727.8FPS = 221.6MPS
 RVFLAVG= 606.6FPS = 184.9MPS AXVELAVG= 572.6FPS = 174.5MPS U= 650.FPS = 198.MPS

THETA	SEG NO	VFL	MN	PS	PT	TT	WBL LBM/SEC	WBL KG/SEC	DF	INCIDENCE IN DEG	ALPHA IN DEG	AXIAL VEL	REL VEL
44.	1	1.011	6.5216	1.0050	1.0106	0.9916	0.0	0.0	0.192	-3.74	52.8	1.024	1.024
54.	2	1.011	0.5218	1.0050	1.0107	0.9906	0.0	0.0	0.192	-3.73	52.8	1.023	1.023
64.	3	1.011	0.5218	1.0048	1.0106	0.9899	0.0	0.0	0.193	-3.72	52.8	1.023	1.023
74.	4	1.010	0.5219	1.0050	1.0108	0.9895	0.0	0.0	0.193	-3.71	52.8	1.023	1.023
84.	5	1.011	6.5221	1.0048	1.0107	0.9892	0.0	0.0	0.193	-3.73	52.8	1.023	1.023
94.	6	1.010	0.5219	1.0047	1.0105	0.9889	0.0	0.0	0.193	-3.70	52.8	1.023	1.023
104.	7	1.010	0.5218	1.0043	1.0101	0.9885	0.0	0.0	0.194	-3.67	52.8	1.022	1.022
114.	8	1.009	6.5214	1.0038	1.0092	0.9879	0.0	0.0	0.196	-3.59	52.7	1.020	1.020
124.	9	0.999	0.5171	1.0003	1.0027	0.9853	0.0	0.0	0.212	-2.89	52.0	1.002	1.002
134.	10	0.995	0.5150	0.9966	0.9977	0.9829	0.0	0.0	0.223	-2.44	51.5	0.991	0.991
144.	11	0.994	0.5150	0.9961	0.9972	0.9821	0.0	0.0	0.226	-2.33	51.4	0.988	0.988
154.	12	0.992	0.5136	0.9949	0.9950	0.9822	0.0	0.0	0.230	-2.13	51.2	0.984	0.984
164.	13	0.990	0.5120	0.9944	0.9935	0.9846	0.0	0.0	0.233	-2.02	51.1	0.981	0.981
174.	14	0.989	6.5103	0.9948	0.9927	0.9896	0.0	0.0	0.233	-1.99	51.1	0.980	0.980
184.	15	0.989	0.5088	0.9953	0.9922	0.9958	0.0	0.0	0.232	-2.00	51.1	0.980	0.980
194.	16	0.990	0.5077	0.9955	0.9916	1.0013	0.0	0.0	0.232	-2.07	51.1	0.981	0.981
204.	17	0.990	0.5069	0.9956	0.9911	1.0051	0.0	0.0	0.232	-2.01	51.1	0.981	0.981
214.	18	0.990	0.5061	0.9955	0.9905	1.0074	0.0	0.0	0.233	-1.95	51.1	0.979	0.979
224.	19	0.989	0.5054	0.9954	0.9899	1.0089	0.0	0.0	0.234	-1.89	51.0	0.978	0.978
234.	20	0.989	0.5049	0.9949	0.9890	1.0098	0.0	0.0	0.236	-1.83	50.9	0.976	0.976
244.	21	0.988	6.5045	0.9947	0.9886	1.0106	0.0	0.0	0.237	-1.78	50.9	0.975	0.975
254.	22	0.988	0.5041	0.9944	0.9880	1.0111	0.0	0.0	0.238	-1.72	50.8	0.974	0.974
264.	23	0.987	0.5037	0.9941	0.9875	1.0114	0.0	0.0	0.240	-1.67	50.8	0.972	0.972
274.	24	0.987	0.5033	0.9938	0.9869	1.0116	0.0	0.0	0.241	-1.61	50.7	0.971	0.971
284.	25	0.988	0.5039	0.9943	0.9878	1.0120	0.0	0.0	0.239	-1.69	50.8	0.973	0.973
294.	26	0.991	0.5051	0.9953	0.9896	1.0125	0.0	0.0	0.234	-1.89	51.0	0.978	0.978
304.	27	0.997	0.5082	0.9985	0.9948	1.0140	0.0	0.0	0.222	-2.41	51.5	0.990	1.990
314.	28	1.004	0.5116	1.0021	1.0007	1.0160	0.0	0.0	0.207	-3.04	52.1	1.006	1.006
324.	29	1.007	0.5130	1.0041	1.0036	1.0168	0.0	0.0	0.200	-3.34	52.4	1.013	1.013
334.	30	1.010	0.5147	1.0057	1.0043	1.0166	0.0	0.0	0.194	-3.60	52.7	1.020	1.020
344.	31	1.012	0.5163	1.0065	1.0083	1.0142	0.0	0.0	0.191	-3.75	52.8	1.024	1.024
354.	32	1.013	0.5179	1.0068	1.0097	1.0099	0.0	0.0	0.189	-3.81	52.9	1.025	1.025
4.	33	1.013	0.5194	1.0061	1.0101	1.0043	0.0	0.0	0.189	-3.82	52.9	1.026	1.026
14.	34	1.012	0.5203	1.0057	1.0104	0.9992	0.0	0.0	0.191	-3.78	52.9	1.025	1.025
24.	35	1.011	0.5208	1.0063	1.0112	0.9996	0.0	0.0	0.192	-3.73	52.8	1.023	1.023
34.	36	1.012	0.5215	1.0050	1.0105	0.9990	0.0	0.0	0.191	-3.76	52.9	1.024	1.024

HIGH SPOOL OUTPUT

	COND FLOW	PRESS RATIO	EFFICIENCY
HIGH SPOOL PERFORMANCE 4/3	26.09 LBM/SEC 11.84 KG/SEC	2.742	0.810

--- ROW OUTPUT ---

STAGE 10 ROTOR

FLOW SWIRL= 43.95DEG PARTICLE SWIRL=107.88DEG PSAVG= 30.39PSIA = 209553.PA
 PTAVG= 34.64PSIA = 238852.PA TTAVG= 886.2DEG R = 492.40EG K VELAVG= 627.3FPS = 191.2MPS
 RVFLAVG= 921.0FPS = 280.7MPS AXVELAVG= 568.5FPS = 173.3MPS U= 990.FPS = 302.MPS

THETA	SEG NO	VEL	MN	PS	PT	TT	WBL LBM/SEC	WBL KG/SEC	DF	INCIDENCE IN DEG	BETA IN DEG	AXIAL VEL	REL VEL
54.	1	1.002	0.4424	1.0075	1.0092	0.9914	0.062	0.028	0.333	5.79	38.2	1.002	1.000
64.	2	1.004	0.4434	1.0067	1.0089	0.9906	0.062	0.028	0.332	5.74	38.3	1.004	1.001
74.	3	1.004	0.4440	1.0062	1.0087	0.9899	0.061	0.028	0.331	5.71	38.3	1.004	1.001
84.	4	1.005	0.4443	1.0066	1.0093	0.9899	0.060	0.027	0.330	5.69	38.3	1.005	1.001
94.	5	1.005	0.4446	1.0067	1.0096	0.9892	0.061	0.028	0.330	5.67	38.3	1.005	1.001
104.	6	1.004	0.4448	1.0061	1.0091	0.9889	0.060	0.027	0.330	5.66	38.3	1.006	1.001
114.	7	1.004	0.4449	1.0054	1.0085	0.9885	0.057	0.026	0.330	5.66	38.3	1.006	1.001
124.	8	1.006	0.4450	1.0047	1.0078	0.9879	0.050	0.023	0.330	5.66	38.3	1.006	1.001
134.	9	1.005	0.4455	0.9991	1.0025	0.9853	-0.002	-0.001	0.330	5.67	38.3	1.005	1.001
144.	10	1.005	0.4459	0.9993	0.9990	0.9829	-0.071	-0.032	0.330	5.68	38.3	1.005	1.001
154.	11	1.005	0.4461	0.9993	0.9981	0.9821	-0.081	-0.037	0.331	5.68	38.3	1.005	1.001
164.	12	1.005	0.4461	0.9927	0.9964	0.9822	-0.091	-0.041	0.331	5.68	38.3	1.005	1.001
174.	13	1.004	0.4457	0.9916	0.9952	0.9846	-0.093	-0.042	0.331	5.66	38.3	1.006	1.001
184.	14	1.004	0.4446	0.9917	0.9946	0.9896	-0.090	-0.041	0.332	5.66	38.3	1.006	1.001
194.	15	1.005	0.4428	0.9922	0.9940	0.9958	-0.087	-0.039	0.333	5.69	38.3	1.005	1.001
204.	16	1.003	0.4408	0.9928	0.9934	1.0013	-0.082	-0.037	0.335	5.76	38.2	1.003	1.000
214.	17	1.001	0.4389	0.9934	0.9919	1.0051	-0.078	-0.035	0.337	5.85	38.2	1.001	1.000
224.	18	0.999	0.4374	0.9936	0.9922	1.0074	-0.076	-0.034	0.339	5.93	38.1	0.999	1.000
234.	19	0.997	0.4364	0.9935	0.9916	1.0089	-0.073	-0.033	0.340	5.99	38.0	0.997	1.000
244.	20	0.996	0.4357	0.9933	0.9909	1.0098	-0.070	-0.032	0.341	6.03	38.0	0.996	0.999
254.	21	0.995	0.4353	0.9932	0.9906	1.0106	-0.069	-0.031	0.341	6.04	37.9	0.995	0.999
264.	22	0.995	0.4349	0.9929	0.9901	1.0111	-0.068	-0.031	0.342	6.07	37.9	0.995	0.999
274.	23	0.995	0.4347	0.9925	0.9896	1.0114	-0.065	-0.029	0.342	6.09	37.9	0.995	0.999
284.	24	0.994	0.4345	0.9921	0.9891	1.0116	-0.060	-0.027	0.343	6.10	37.9	0.994	0.999
294.	25	0.994	0.4344	0.9929	0.9898	1.0120	-0.049	-0.022	0.343	6.11	37.9	0.994	0.999
304.	26	0.994	0.4342	0.9944	0.9912	1.0125	-0.026	-0.012	0.343	6.11	37.9	0.994	0.999
314.	27	0.994	0.4341	0.9982	0.9949	1.0140	0.014	0.007	0.342	6.09	37.9	0.994	0.999
324.	28	0.995	0.4339	1.0031	0.9996	1.0160	0.054	0.024	0.341	6.07	37.9	0.995	0.999
334.	29	0.995	0.4339	1.0056	1.0021	1.0168	0.067	0.031	0.340	6.04	37.9	0.995	0.999
344.	30	0.995	0.4339	1.0060	1.0045	1.0166	0.075	0.034	0.340	6.06	37.9	0.995	0.999
354.	31	0.995	0.4343	1.0093	1.0061	1.0142	0.078	0.035	0.340	6.07	37.9	0.995	0.999
4.	32	0.995	0.4353	1.0098	1.0072	1.0099	0.077	0.035	0.339	6.07	37.9	0.995	0.999
14.	33	0.996	0.4368	1.0099	1.0081	1.0043	0.074	0.033	0.339	6.04	38.0	0.996	0.999
24.	34	0.997	0.4385	1.0089	1.0082	0.9992	0.070	0.032	0.337	5.99	38.0	0.997	1.000
34.	35	0.999	0.4401	1.0083	1.0086	0.9956	0.064	0.029	0.336	5.92	38.1	0.999	1.000
44.	36	1.001	0.4415	1.0077	1.0088	0.9930	0.063	0.028	0.334	5.86	38.1	1.001	1.000

APPENDIX B (Cont'd)

STATOR

FLOW SWIRL = 45.67DEG PTAVG = 44.25PSIA = 305083.PA RVELAVG = 747.2FPS = 227.7MPS				PARTICLE SWIRL = 114.34DEG TTAVG = 955.8DEG R = 531.0DEG K AXVELAVG = 625.3FPS = 190.6MPS				PSAVG = 35.09PSIA = 241913.PA VELAVG = 858.9FPS = 261.8MPS U = 998.1FPS = 304.MPS					
THETA	SEG	VEL	MN	PS	PT	TT	MBL	MBL	DF	INCIDENCE	ALPHA	AXIAL	REL
	NO						LBM/SEC	KG/SEC		IN DEG	IN DEG	VEL	VEL
56.	1	1.001	0.5917	1.0075	1.0099	0.9927	0.0	0.0	0.374	3.72	46.9	1.003	1.003
66.	2	1.001	0.5920	1.0067	1.0094	0.9915	0.0	0.0	0.373	3.67	46.9	1.004	1.004
76.	3	1.001	0.5923	1.0062	1.0091	0.9908	0.0	0.0	0.372	3.62	47.0	1.005	1.005
86.	4	1.001	0.5924	1.0066	1.0097	0.9903	0.0	0.0	0.372	3.60	47.0	1.006	1.006
96.	5	1.001	0.5925	1.0068	1.0099	0.9900	0.0	0.0	0.371	3.58	47.0	1.006	1.006
106.	6	1.001	0.5926	1.0061	1.0093	0.9895	0.0	0.0	0.371	3.57	47.0	1.006	1.006
116.	7	1.001	0.5927	1.0056	1.0089	0.9892	0.0	0.0	0.371	3.57	47.0	1.006	1.006
126.	8	1.001	0.5928	1.0050	1.0084	0.9888	0.0	0.0	0.371	3.58	47.0	1.006	1.006
136.	9	1.002	0.5936	0.9999	1.0038	0.9867	0.0	0.0	0.372	3.59	47.0	1.006	1.006
146.	10	1.002	0.5942	0.9965	1.0004	0.9847	0.0	0.0	0.372	3.60	47.0	1.006	1.006
156.	11	1.001	0.5944	0.9956	1.0001	0.9835	0.0	0.0	0.373	3.62	47.0	1.005	1.005
166.	12	1.001	0.5943	0.9937	0.9982	0.9831	0.0	0.0	0.373	3.63	47.0	1.005	1.005
176.	13	1.000	0.5934	0.9922	0.9961	0.9844	0.0	0.0	0.373	3.65	47.0	1.005	1.005
186.	14	0.999	0.5917	0.9918	0.9942	0.9879	0.0	0.0	0.374	3.68	46.9	1.004	1.004
196.	15	0.998	0.5895	0.9919	0.9927	0.9932	0.0	0.0	0.375	3.75	46.9	1.003	1.003
206.	16	0.998	0.5877	0.9925	0.9919	0.9988	0.0	0.0	0.376	3.82	46.8	1.001	1.001
216.	17	0.996	0.5864	0.9933	0.9916	1.0032	0.0	0.0	0.378	3.91	46.7	0.999	0.999
226.	18	0.998	0.5856	0.9935	0.9912	1.0060	0.0	0.0	0.379	3.99	46.6	0.997	0.997
236.	19	0.998	0.5851	0.9935	0.9908	1.0077	0.0	0.0	0.381	4.06	46.5	0.996	0.996
246.	20	0.998	0.5849	0.9933	0.9904	1.0088	0.0	0.0	0.382	4.11	46.5	0.995	0.995
256.	21	0.999	0.5847	0.9931	0.9901	1.0096	0.0	0.0	0.382	4.13	46.5	0.995	0.995
266.	22	0.999	0.5845	0.9928	0.9896	1.0102	0.0	0.0	0.383	4.16	46.4	0.994	0.994
276.	23	0.999	0.5844	0.9924	0.9892	1.0106	0.0	0.0	0.383	4.17	46.4	0.994	0.994
286.	24	0.999	0.5844	0.9921	0.9888	1.0108	0.0	0.0	0.383	4.18	46.4	0.994	0.994
296.	25	0.999	0.5842	0.9929	0.9896	1.0112	0.0	0.0	0.383	4.19	46.4	0.993	0.993
306.	26	0.999	0.5841	0.9942	0.9908	1.0117	0.0	0.0	0.382	4.16	46.4	0.994	0.994
316.	27	0.999	0.5838	0.9975	0.9938	1.0129	0.0	0.0	0.381	4.11	46.5	0.995	0.995
326.	28	0.999	0.5834	1.0018	0.9978	1.0147	0.0	0.0	0.381	4.08	46.5	0.996	0.996
336.	29	0.999	0.5833	1.0041	1.0000	1.0156	0.0	0.0	0.380	4.07	46.5	0.996	0.996
346.	30	0.999	0.5834	1.0067	1.0026	1.0159	0.0	0.0	0.380	4.06	46.5	0.996	0.996
356.	31	1.000	0.5842	1.0086	1.0051	1.0146	0.0	0.0	0.380	4.04	46.6	0.996	0.996
6.	32	1.001	0.5856	1.0097	1.0073	1.0114	0.0	0.0	0.379	3.99	46.6	0.998	0.998
16.	33	1.002	0.5874	1.0102	1.0093	1.0067	0.0	0.0	0.378	3.94	46.7	0.999	0.999
26.	34	1.002	0.5691	1.0094	1.0098	1.0015	0.0	0.0	0.377	3.86	46.7	1.000	1.000
36.	35	1.002	0.5903	1.0085	1.0099	0.9975	0.0	0.0	0.376	3.79	46.8	1.002	1.002
46.	36	1.002	0.5912	1.0079	1.0099	0.9946	0.0	0.0					

STAGE II ROTOR

FLOW SWIRL = 48.80DEG PTAVG = 43.27PSIA = 298336.PA RVELAVG = 956.3FPS = 291.5MPS				PARTICLE SWIRL = 117.46DEG TTAVG = 955.8DEG R = 531.0DEG K AXVELAVG = 624.1FPS = 190.2MPS				PSAVG = 37.42PSIA = 258023.PA VELAVG = 683.4FPS = 208.3MPS U = 1003.FPS = 306.MPS					
THETA	SEG	VEL	MN	PS	PT	TT	MBL	MBL	DF	INCIDENCE	BETA	AXIAL	REL
	NO						LBM/SEC	KG/SEC		IN DEG	IN DEG	VEL	VEL
59.	1	1.003	0.4657	1.0081	1.0099	0.9927	0.0	0.0	0.310	-0.75	40.8	1.003	1.001
69.	2	1.004	0.4665	1.0073	1.0097	0.9915	0.0	0.0	0.309	-0.79	40.9	1.004	1.001
79.	3	1.005	0.4671	1.0069	1.0096	0.9908	0.0	0.0	0.308	-0.82	40.9	1.005	1.001
89.	4	1.005	0.4674	1.0073	1.0103	0.9903	0.0	0.0	0.307	-0.84	40.9	1.005	1.001
99.	5	1.005	0.4676	1.0075	1.0106	0.9900	0.0	0.0	0.307	-0.85	41.0	1.005	1.001
109.	6	1.006	0.4679	1.0069	1.0101	0.9895	0.0	0.0	0.307	-0.86	41.0	1.006	1.001
119.	7	1.006	0.4679	1.0064	1.0096	0.9892	0.0	0.0	0.307	-0.86	41.0	1.006	1.001
129.	8	1.005	0.4679	1.0059	1.0091	0.9888	0.0	0.0	0.308	-0.84	40.9	1.005	1.001
139.	9	1.005	0.4682	1.0009	1.0044	0.9867	0.0	0.0	0.308	-0.84	40.9	1.005	1.001
149.	10	1.005	0.4685	0.9977	1.0014	0.9847	0.0	0.0	0.309	-0.82	40.9	1.004	1.001
159.	11	1.004	0.4685	0.9969	1.0006	0.9835	0.0	0.0	0.310	-0.80	40.9	1.004	1.001
169.	12	1.004	0.4685	0.9951	0.9988	0.9831	0.0	0.0	0.311	-0.79	40.9	1.004	1.001
179.	13	1.004	0.4681	0.9935	0.9969	0.9844	0.0	0.0	0.312	-0.78	40.9	1.004	1.001
189.	14	1.003	0.4670	0.9927	0.9954	0.9879	0.0	0.0	0.313	-0.76	40.9	1.003	1.001
199.	15	1.002	0.4652	0.9924	0.9940	0.9932	0.0	0.0	0.315	-0.72	40.8	1.002	1.000
209.	16	1.001	0.4634	0.9926	0.9930	0.9988	0.0	0.0	0.316	-0.67	40.8	1.001	1.000
219.	17	0.999	0.4616	0.9930	0.9923	1.0032	0.0	0.0	0.318	-0.61	40.7	0.999	1.000
229.	18	0.998	0.4602	0.9930	0.9914	1.0060	0.0	0.0	0.319	-0.56	40.7	0.998	1.000
239.	19	0.997	0.4592	0.9929	0.9907	1.0077	0.0	0.0	0.320	-0.50	40.6	0.997	0.999
249.	20	0.996	0.4586	0.9926	0.9900	1.0088	0.0	0.0	0.321	-0.47	40.6	0.996	0.999
259.	21	0.995	0.4582	0.9924	0.9895	1.0096	0.0	0.0	0.321	-0.46	40.6	0.995	0.999
269.	22	0.995	0.4579	0.9920	0.9890	1.0102	0.0	0.0	0.322	-0.44	40.5	0.995	0.999
279.	23	0.995	0.4576	0.9917	0.9885	1.0166	0.0	0.0	0.322	-0.43	40.5	0.995	0.999
289.	24	0.994	0.4575	0.9913	0.9880	1.0106	0.0	0.0	0.322	-0.42	40.5	0.994	0.999
299.	25	0.994	0.4573	0.9921	0.9887	1.0112	0.0	0.0	0.322	-0.41	40.5	0.994	0.999
309.	26	0.994	0.4572	0.9934	0.9900	1.0117	0.0	0.0	0.322	-0.42	40.5	0.995	0.999
319.	27	0.995	0.4573	0.9966	0.9932	1.0129	0.0	0.0	0.321	-0.44	40.5	0.996	0.999
329.	28	0.996	0.4574	1.0004	0.9973	1.0147	0.0	0.0	0.319	-0.49	40.6	0.997	0.999
339.	29	0.997	0.4575	1.0029	0.9996	1.0156	0.0	0.0	0.318	-0.51	40.6	0.997	0.999
349.	30	0.997	0.4576	1.0054	1.0022	1.0159	0.0	0.0	0.317	-0.52	40.6	0.997	0.999
359.	31	0.997	0.4580	1.0074	1.0044	1.0146	0.0	0.0	0.317	-0.53	40.6	0.997	0.999
9.	32	0.998	0.4589	1.0088	1.0063	1.0114	0.0	0.0	0.316	-0.54	40.7	0.998	1.000
19.	33	0.998	0.4602	1.0097	1.0081	1.0067	0.0	0.0	0.315	-0.57	40.7	0.998	1.000
29.	34	0.999	0.4618	1.0093	1.0067	1.0015	0.0	0.0	0.314	-0.60	40.7	0.999	1.000
39.	35	1.000	0.4634	1.0087	1.0092	0.9975	0.0	0.0	0.312	-0.65	40.8	1.000	1.000
49.	36	1.001	0.4647	1.0083	1.0095	0.9946	0.0	0.0	0.311	-0.70	40.8	1.001	1.002

APPENDIX B (Cont'd)

STATOR

FLOW SWIRL= 49.84DEG PARTICLE SWIRL=122.07DEG PSAVG= 41.85PSIA = 288550.PA
 PTAVG= 51.37PSIA = 354186.PA TTAVG=1013.1DEG R = 562.8DEG K VELAVG= 832.7FPS = 253.8MPS
 RVELAVG= 773.0FPS = 235.6MPS AXVELAVG= 623.4FPS = 190.0MPS U=1009.FPS = 308.MPS

THETA	SEG NO	VEL	MM	PS	PT	TT	MBL LBM/SEC	MBL KG/SEC	DF	INCIDENCE IN DEG	ALPHA IN DEG	AXIAL REL VEL
60.	1	1.002	0.5556	1.0071	1.0092	0.9936	0.0	0.0	0.279	-0.71	48.7	1.005
70.	2	1.002	0.5559	1.0061	1.0084	0.9921	0.0	0.0	0.278	-0.76	48.8	1.006
80.	3	1.002	0.5562	1.0053	1.0079	0.9912	0.0	0.0	0.277	-0.81	48.8	1.007
90.	4	1.002	0.5563	1.0057	1.0084	0.9908	0.0	0.0	0.276	-0.84	48.8	1.007
100.	5	1.002	0.5565	1.0057	1.0085	0.9903	0.0	0.0	0.276	-0.86	48.9	1.008
110.	6	1.002	0.5564	1.0051	1.0079	0.9899	0.0	0.0	0.276	-0.87	48.9	1.008
120.	7	1.002	0.5566	1.0047	1.0076	0.9896	0.0	0.0	0.276	-0.86	48.9	1.008
130.	8	1.001	0.5566	1.0046	1.0075	0.9892	0.0	0.0	0.277	-0.84	48.8	1.007
140.	9	1.001	0.5571	1.0003	1.0035	0.9875	0.0	0.0	0.277	-0.80	48.8	1.006
150.	10	1.001	0.5576	0.9978	1.0014	0.9856	0.0	0.0	0.278	-0.76	48.6	1.006
160.	11	1.001	0.5577	0.9976	1.0013	0.9847	0.0	0.0	0.280	-0.70	48.7	1.005
170.	12	1.001	0.5577	0.9960	0.9997	0.9839	0.0	0.0	0.281	-0.67	48.7	1.004
180.	13	1.000	0.5571	0.9943	0.9976	0.9844	0.0	0.0	0.282	-0.62	48.6	1.003
190.	14	0.999	0.5558	0.9932	0.9955	0.9869	0.0	0.0	0.283	-0.55	48.6	1.002
200.	15	0.998	0.5540	0.9928	0.9938	0.9913	0.0	0.0	0.285	-0.46	48.5	1.000
210.	16	0.998	0.5523	0.9927	0.9925	0.9965	0.0	0.0	0.286	-0.40	48.4	0.999
220.	17	0.998	0.5510	0.9935	0.9922	1.0013	0.0	0.0	0.287	-0.31	48.3	0.997
230.	18	0.998	0.5501	0.9939	0.9920	1.0047	0.0	0.0	0.288	-0.24	48.2	0.996
240.	19	0.998	0.5496	0.9942	0.9919	1.0068	0.0	0.0	0.290	-0.18	48.2	0.994
250.	20	0.998	0.5493	0.9941	0.9916	1.0081	0.0	0.0	0.291	-0.14	48.1	0.994
260.	21	0.998	0.5492	0.9957	0.9911	1.0090	0.0	0.0	0.291	-0.12	48.1	0.993
270.	22	0.998	0.5490	0.9956	0.9908	1.0097	0.0	0.0	0.291	-0.10	48.1	0.993
280.	23	0.998	0.5489	0.9953	0.9904	1.0101	0.0	0.0	0.292	-0.08	48.1	0.993
290.	24	0.998	0.5488	0.9929	0.9901	1.0104	0.0	0.0	0.292	-0.07	48.1	0.992
300.	25	0.998	0.5487	0.9937	0.9908	1.0109	0.0	0.0	0.292	-0.06	48.1	0.992
310.	26	0.999	0.5487	0.9948	0.9918	1.0113	0.0	0.0	0.292	-0.08	48.1	0.992
320.	27	0.999	0.5486	0.9971	0.9940	1.0123	0.0	0.0	0.290	-0.15	48.1	0.994
330.	28	0.999	0.5484	1.0001	0.9969	1.0137	0.0	0.0	0.288	-0.24	48.2	0.996
340.	29	0.999	0.5483	1.0019	0.9986	1.0147	0.0	0.0	0.286	-0.30	48.3	0.997
350.	30	1.000	0.5483	1.0043	1.0010	1.0152	0.0	0.0	0.286	-0.34	48.3	0.997
360.	31	1.000	0.5488	1.0065	1.0035	1.0146	0.0	0.0	0.285	-0.37	48.4	0.998
10.	32	1.001	0.5498	1.0082	1.0060	1.0123	0.0	0.0	0.284	-0.41	48.4	0.999
20.	33	1.002	0.5513	1.0095	1.0084	1.0084	0.0	0.0	0.283	-0.47	48.5	1.000
30.	34	1.002	0.5528	1.0094	1.0094	1.0036	0.0	0.0	0.283	-0.51	48.5	1.001
40.	35	1.002	0.5541	1.0085	1.0095	0.9992	0.0	0.0	0.281	-0.58	48.6	1.002
50.	36	1.002	0.5550	1.0079	1.0095	0.9959	0.0	0.0	0.280	-0.64	48.6	1.003

STAGE 12 ROTOR

FLOW SWIRL= 52.94DEG PARTICLE SWIRL=125.97DEG PSAVG= 44.14PSIA = 304363.PA
 PTAVG= 50.81PSIA = 350290.PA TTAVG=1013.1DEG R = 562.8DEG K VELAVG= 692.5FPS = 211.1MPS
 RVELAVG= 945.5FPS = 288.2MPS AXVELAVG= 623.1FPS = 189.9MPS

THETA	SEG NO	VEL	MM	PS	PT	TT	MBL LBM/SEC	MBL KG/SEC	DF	INCIDENCE IN DEG	BETA IN DEG	AXIAL REL VEL
63.	1	1.005	0.4592	1.0072	1.0094	0.9936	0.0	0.0	0.234	-3.71	41.4	1.005
73.	2	1.006	0.4601	1.0061	1.0088	0.9921	0.0	0.0	0.234	-3.75	41.5	1.006
83.	3	1.007	0.4607	1.0053	1.0084	0.9912	0.0	0.0	0.233	-3.79	41.5	1.007
93.	4	1.007	0.4611	1.0056	1.0090	0.9908	0.0	0.0	0.232	-3.81	41.5	1.007
103.	5	1.008	0.4614	1.0056	1.0092	0.9903	0.0	0.0	0.232	-3.83	41.5	1.008
113.	6	1.008	0.4617	1.0049	1.0087	0.9899	0.0	0.0	0.232	-3.84	41.5	1.008
123.	7	1.008	0.4616	1.0047	1.0084	0.9896	0.0	0.0	0.232	-3.83	41.5	1.008
133.	8	1.007	0.4614	1.0046	1.0082	0.9892	0.0	0.0	0.233	-3.81	41.5	1.007
143.	9	1.006	0.4614	1.0006	1.0041	0.9875	0.0	0.0	0.234	-3.77	41.5	1.006
153.	10	1.005	0.4613	0.9984	1.0019	0.9858	0.0	0.0	0.236	-3.74	41.4	1.005
163.	11	1.004	0.4610	0.9984	1.0017	0.9847	0.0	0.0	0.238	-3.68	41.4	1.004
173.	12	1.003	0.4607	0.9969	1.0001	0.9839	0.0	0.0	0.239	-3.65	41.3	1.003
183.	13	1.002	0.4601	0.9953	0.9981	0.9844	0.0	0.0	0.241	-3.61	41.3	1.002
193.	14	1.001	0.4590	0.9941	0.9962	0.9869	0.0	0.0	0.243	-3.56	41.3	1.001
203.	15	0.999	0.4572	0.9935	0.9945	0.9913	0.0	0.0	0.246	-3.49	41.2	0.999
213.	16	0.998	0.4555	0.9932	0.9931	0.9965	0.0	0.0	0.247	-3.45	41.2	0.998
223.	17	0.997	0.4538	0.9937	0.9926	1.0013	0.0	0.0	0.248	-3.40	41.1	0.997
233.	18	0.996	0.4525	0.9940	0.9920	1.0047	0.0	0.0	0.249	-3.35	41.0	0.996
243.	19	0.994	0.4514	0.9943	0.9917	1.0068	0.0	0.0	0.250	-3.30	41.0	0.994
253.	20	0.994	0.4507	0.9942	0.9912	1.0081	0.0	0.0	0.250	-3.27	41.0	0.994
263.	21	0.993	0.4504	0.9938	0.9906	1.0090	0.0	0.0	0.250	-3.26	41.0	0.993
273.	22	0.993	0.4501	0.9936	0.9902	1.0097	0.0	0.0	0.251	-3.24	40.9	0.993
283.	23	0.993	0.4498	0.9933	0.9897	1.0101	0.0	0.0	0.251	-3.23	40.9	0.993
293.	24	0.992	0.4496	0.9930	0.9893	1.0104	0.0	0.0	0.251	-3.22	40.9	0.992
303.	25	0.992	0.4495	0.9937	0.9900	1.0109	0.0	0.0	0.251	-3.21	40.9	0.992
313.	26	0.993	0.4496	0.9947	0.9910	1.0113	0.0	0.0	0.250	-3.23	40.9	0.993
323.	27	0.994	0.4501	0.9968	0.9934	1.0123	0.0	0.0	0.248	-3.29	41.0	0.994
333.	28	0.996	0.4507	0.9994	0.9964	1.0137	0.0	0.0	0.245	-3.37	41.1	0.996
343.	29	0.997	0.4511	1.0010	0.9982	1.0147	0.0	0.0	0.243	-3.42	41.1	0.997
353.	30	0.998	0.4514	1.0033	1.0006	1.0152	0.0	0.0	0.242	-3.46	41.2	0.998
13.	31	0.999	0.4518	1.0055	1.0031	1.0146	0.0	0.0	0.241	-3.48	41.2	0.999
23.	32	1.000	0.4527	1.0073	1.0054	1.0123	0.0	0.0	0.239	-3.52	41.2	1.000
33.	33	1.001	0.4540	1.0088	1.0078	1.0084	0.0	0.0	0.238	-3.55	41.3	1.001
43.	34	1.001	0.4554	1.0090	1.0088	1.0036	0.0	0.0	0.237	-3.58	41.3	1.001
53.	35	1.002	0.4569	1.0084	1.0091	0.9992	0.0	0.0	0.236	-3.62	41.3	1.002
63.	36	1.003	0.4581	1.0079	1.0094	0.9959	0.0	0.0	0.236	-3.66	41.4	1.003

APPENDIX B (Cont'd)

STAYOR

FLOW SWIRL= 53.55DEG PARTICLE SWIRL=130.67DEG PSYVG= 48.17PSIA = 332101.PA
 PTAVG= 58.15PSIA = 400912.PA TTAVG=1058.6DEG R = 588.1DEG K VELAVG= 816.8FPS =249.0MPS
 RVELAVG= 810.2FPS = 246.9MPS AKVELAVG= 633.9FPS =193.2MPS U=1020.FPS = 311.MPS

THETA	SEG NO	VEL	MN	PS	PT	TT	NBL LBM/SEC	NBL KG/SEC	DF	INCIDENCE IN DEG	BETA IN DEG	AXIAL VEL	REL VEL
64.	1	1.002	0.5325	1.0061	1.0061	0.9943	0.006	0.003	0.189	-5.25	51.3	1.006	1.006
74.	2	1.002	0.5329	1.0050	1.0073	0.9925	0.005	0.002	0.188	-5.29	51.3	1.007	1.007
84.	3	1.002	0.5332	1.0040	1.0066	0.9913	0.005	0.002	0.187	-5.34	51.3	1.008	1.008
94.	4	1.002	0.5333	1.0044	1.0070	0.9908	0.005	0.002	0.186	-5.37	51.4	1.008	1.008
104.	5	1.002	0.5335	1.0044	1.0071	0.9903	0.005	0.002	0.186	-5.39	51.4	1.009	1.009
114.	6	1.002	0.5336	1.0038	1.0066	0.9898	0.005	0.002	0.186	-5.40	51.4	1.009	1.009
124.	7	1.002	0.5335	1.0039	1.0066	0.9896	0.004	0.002	0.186	-5.37	51.4	1.008	1.008
134.	8	1.002	0.5334	1.0042	1.0068	0.9893	0.003	0.001	0.187	-5.33	51.3	1.008	1.008
144.	9	1.001	0.5336	1.0006	1.0036	0.9880	0.001	0.001	0.189	-5.26	51.3	1.006	1.006
154.	10	1.001	0.5339	0.9991	1.0022	0.9866	0.0	0.0	0.190	-5.20	51.2	1.005	1.005
164.	11	1.001	0.5339	0.9999	1.0030	0.9857	-0.002	-0.001	0.193	-5.09	51.1	1.003	1.003
174.	12	1.000	0.5339	0.9986	1.0017	0.9848	-0.004	-0.002	0.195	-5.02	51.0	1.002	1.002
184.	13	1.000	0.5335	0.9972	1.0000	0.9848	-0.006	-0.003	0.197	-4.93	50.9	1.000	1.000
194.	14	0.998	0.5324	0.9962	0.9982	0.9865	-0.008	-0.003	0.199	-4.81	50.8	0.998	0.998
204.	15	0.997	0.5308	0.9956	0.9965	0.9901	-0.010	-0.004	0.202	-4.68	50.7	0.996	0.996
214.	16	0.997	0.5294	0.9946	0.9944	0.9948	-0.010	-0.004	0.203	-4.63	50.6	0.995	0.995
224.	17	0.997	0.5280	0.9951	0.9959	0.9997	-0.009	-0.004	0.204	-4.57	50.6	0.994	0.994
234.	18	0.997	0.5272	0.9952	0.9934	1.0035	-0.008	-0.004	0.205	-4.53	50.5	0.993	0.993
244.	19	0.997	0.5266	0.9955	0.9933	1.0062	-0.007	-0.003	0.206	-4.48	50.5	0.992	0.992
254.	20	0.996	0.5263	0.9953	0.9929	1.0078	-0.006	-0.003	0.206	-4.46	50.5	0.992	0.992
264.	21	0.996	0.5262	0.9947	0.9922	1.0087	-0.005	-0.002	0.206	-4.47	50.5	0.992	0.992
274.	22	0.996	0.5259	0.9946	0.9920	1.0095	-0.005	-0.002	0.207	-4.44	50.4	0.992	0.992
284.	23	0.996	0.5258	0.9943	0.9916	1.0100	-0.005	-0.002	0.207	-4.43	50.4	0.991	0.991
294.	24	0.996	0.5258	0.9940	0.9912	1.0104	-0.004	-0.002	0.207	-4.42	50.4	0.991	0.991
304.	25	0.998	0.5257	0.9946	0.9918	1.0109	-0.004	-0.002	0.207	-4.42	50.4	0.991	0.991
314.	26	0.996	0.5257	0.9953	0.9925	1.0113	-0.003	-0.002	0.206	-4.45	50.5	0.992	0.992
324.	27	0.994	0.5250	0.9963	0.9937	1.0119	-0.001	-0.000	0.203	-4.56	50.4	0.994	0.994
334.	28	1.000	0.5260	0.9979	0.9953	1.0129	0.002	0.001	0.200	-4.73	50.7	0.997	0.997
344.	29	1.000	0.5259	0.9984	0.9966	1.0138	0.004	0.002	0.198	-4.81	50.8	0.998	0.998
354.	30	1.000	0.5258	1.0015	0.9987	1.0145	0.005	0.002	0.197	-4.87	50.9	0.999	0.999
1.	31	1.001	0.5241	1.0037	1.0012	1.0144	0.006	0.003	0.195	-4.93	50.9	1.000	1.000
14.	32	1.001	0.5271	1.0054	1.0055	1.0127	0.006	0.004	0.193	-5.01	51.0	1.002	1.002
24.	33	1.002	0.5283	1.0072	1.0061	1.0096	0.009	0.004	0.192	-5.09	51.1	1.003	1.003
34.	34	1.002	0.5296	1.0079	1.0078	1.0052	0.008	0.004	0.191	-5.12	51.1	1.004	1.004
44.	35	1.003	0.5308	1.0074	1.0082	1.0007	0.007	0.003	0.191	-5.16	51.2	1.005	1.005
54.	36	1.002	0.5317	1.0070	1.0085	0.9970	0.006	0.003	0.190	-5.19	51.2	1.005	1.005

STAGE 13 MOTOR

FLOW SWIRL= 56.52DEG PARTICLE SWIRL=133.64DEG PSYVG= 50.16PSIA = 34583E.PA
 PTAVG= 58.14PSIA = 400890.PA TTAVG=1058.6DEG R = 588.1DEG K VELAVG= 725.4FPS =221.1MPS
 RVELAVG= 742.3FPS = 227.2MPS AKVELAVG= 643.3FPS =196.1MPS U=1024.FPS = 312.MPS

THETA	SEG NO	VEL	MN	PS	PT	TT	NBL LBM/SEC	NBL KG/SEC	DF	INCIDENCE IN DEG	BETA IN DEG	AXIAL VEL	REL VEL
67.	1	1.001	0.4697	1.0071	1.0083	0.9943	0.0	0.0	0.254	-8.11	43.1	1.001	1.000
77.	2	1.002	0.4708	1.0058	1.0077	0.9925	0.0	0.0	0.253	-8.16	43.2	1.002	1.001
87.	3	1.003	0.4715	1.0047	1.0070	0.9913	0.0	0.0	0.252	-8.20	43.2	1.003	1.001
97.	4	1.004	0.4718	1.0050	1.0076	0.9908	0.0	0.0	0.251	-8.22	43.2	1.004	1.001
107.	5	1.004	0.4721	1.0050	1.0077	0.9903	0.0	0.0	0.251	-8.23	43.2	1.004	1.001
117.	6	1.004	0.4723	1.0044	1.0073	0.9898	0.0	0.0	0.251	-8.25	43.2	1.004	1.001
127.	7	1.005	0.4725	1.0044	1.0074	0.9896	0.0	0.0	0.251	-8.25	43.3	1.005	1.001
137.	8	1.005	0.4726	1.0046	1.0076	0.9893	0.0	0.0	0.251	-8.26	43.3	1.005	1.001
147.	9	1.005	0.4730	1.0012	1.0044	0.9880	0.0	0.0	0.251	-8.26	43.3	1.005	1.001
157.	10	1.005	0.4732	0.9995	1.0030	0.9866	0.0	0.0	0.251	-8.25	43.3	1.005	1.001
167.	11	1.005	0.4734	0.9999	1.0034	0.9857	0.0	0.0	0.251	-8.25	43.3	1.005	1.001
177.	12	1.005	0.4738	0.9981	1.0020	0.9848	0.0	0.0	0.251	-8.27	43.3	1.005	1.001
187.	13	1.005	0.4739	0.9982	1.0020	0.9848	0.0	0.0	0.251	-8.28	43.3	1.005	1.001
197.	14	1.005	0.4735	0.9984	0.9940	0.9865	0.0	0.0	0.251	-8.28	43.3	1.005	1.001
207.	15	1.005	0.4725	0.9932	0.9962	0.9901	0.0	0.0	0.252	-8.27	43.3	1.005	1.001
217.	16	1.004	0.4711	0.9921	0.9941	0.9948	0.0	0.0	0.253	-8.24	43.2	1.004	1.001
227.	17	1.003	0.4692	0.9927	0.9925	0.9947	0.0	0.0	0.253	-8.17	43.2	1.003	1.001
237.	18	1.001	0.4675	0.9932	0.9930	1.0035	0.0	0.0	0.257	-8.10	43.1	1.001	1.000
247.	19	0.999	0.4660	0.9940	0.9928	1.0042	0.0	0.0	0.259	-8.02	43.0	0.999	1.000
257.	20	0.998	0.4648	0.9942	0.9923	1.0078	0.0	0.0	0.261	-7.96	43.0	0.998	1.000
267.	21	0.997	0.4641	0.9940	0.9917	1.0087	0.0	0.0	0.262	-7.92	42.9	0.997	0.999
277.	22	0.996	0.4636	0.9941	0.9914	1.0095	0.0	0.0	0.263	-7.88	42.9	0.996	0.999
287.	23	0.995	0.4632	0.9939	0.9910	1.0100	0.0	0.0	0.263	-7.86	42.9	0.995	0.999
297.	24	0.995	0.4629	0.9937	0.9906	1.0104	0.0	0.0	0.264	-7.84	42.8	0.995	0.999
307.	25	0.995	0.4627	0.9944	0.9912	1.0109	0.0	0.0	0.264	-7.83	42.8	0.995	0.999
317.	26	0.995	0.4625	0.9953	0.9920	1.0113	0.0	0.0	0.264	-7.82	42.8	0.995	0.999
327.	27	0.994	0.4623	0.9970	0.9935	1.0119	0.0	0.0	0.264	-7.82	42.8	0.995	0.999
337.	28	0.995	0.4622	0.9989	0.9954	1.0129	0.0	0.0	0.263	-7.83	42.8	0.995	0.999
347.	29	0.995	0.4621	1.0004	0.9967	1.0138	0.0	0.0	0.263	-7.84	42.8	0.995	0.999
357.	30	0.995	0.4619	1.0025	0.9988	1.0145	0.0	0.0	0.263	-7.84	42.8	0.995	0.999
7.	31	0.995	0.4621	1.0048	1.0012	1.0144	0.0	0.0	0.262	-7.85	42.8	0.995	0.999
17.	32	0.995	0.4625	1.0067	1.0033	1.0127	0.0	0.0	0.261	-7.87	42.9	0.996	0.999
27.	33	0.996	0.4635	1.0086	1.0058	1.0096	0.0	0.0	0.260	-7.87	42.9	0.997	0.999
37.	34	0.997	0.4650	1.0094	1.0076	1.0052	0.0	0.0	0.259	-7.92	42.9	0.998	1.000
47.	35	0.998	0.4667	1.0088	1.0081	1.0007	0.0	0.0	0.257	-7.98	43.0	0.998	1.000
57.	36	1.000	0.4683	1.0082	1.0085	0.9970	0.0	0.0	0.255	-8.04	43.0	1.000	1.000

APPENDIX B (Cont'd)

STATOR		FLDN SWIRL = 57.37DEG				PARTICLE SWIRL = 138.63DEG				PSAVG = 54.73PSIA = 377360.PA			
		PTAVG = 66.76PSIA = 440309.PA				TIAVG = 1110.90DEG R = 617.2DEG K				VELAVG = 859.1FPS = 261.6MPS			
		RVELAVG = 803.1FPS = 244.8MPS				AXVELAVG = 651.7FPS = 198.6MPS				U = 1029.FPS = 314.MPS			
THETA	SEG	VEL	NN	PS	PT	TT	WBL	WBL	DF	INCIDENCE	ALPHA	AXIAL	REL
	NO						LBM/SEC	KG/SEC		IN DEG	IN DEG	VEL	VEL
67.	1	1.602	0.5473	1.0067	1.0083	0.9955	0.0	0.0	0.268	-3.98	49.5	1.003	1.003
77.	2	1.002	0.5476	1.0054	1.0074	0.9933	0.0	0.0	0.267	-4.03	49.5	1.004	1.004
87.	3	1.001	0.5482	1.0043	1.0066	0.9919	0.0	0.0	0.266	-4.07	49.6	1.004	1.004
97.	4	1.001	0.5483	1.0046	1.0070	0.9912	0.0	0.0	0.266	-4.09	49.6	1.005	1.005
107.	5	1.001	0.5484	1.0046	1.0071	0.9907	0.0	0.0	0.266	-4.10	49.6	1.005	1.005
117.	6	1.001	0.5485	1.0041	1.0066	0.9902	0.0	0.0	0.265	-4.11	49.6	1.005	1.005
127.	7	1.001	0.5486	1.0041	1.0067	0.9899	0.0	0.0	0.265	-4.12	49.6	1.005	1.005
137.	8	1.001	0.5467	1.0042	1.0069	0.9897	0.0	0.0	0.265	-4.13	49.6	1.006	1.006
147.	9	1.001	0.5490	1.0011	1.0040	0.9885	0.0	0.0	0.265	-4.12	49.6	1.006	1.006
157.	10	1.001	0.5494	0.9998	1.0030	0.9874	0.0	0.0	0.266	-4.11	49.6	1.005	1.005
167.	11	1.001	0.5496	1.0002	1.0036	0.9866	0.0	0.0	0.266	-4.11	49.6	1.005	1.005
177.	12	1.001	0.5499	0.9984	1.0028	0.9854	0.0	0.0	0.266	-4.12	49.6	1.006	1.006
187.	13	1.001	0.5499	0.9963	0.9999	0.9850	0.0	0.0	0.266	-4.12	49.6	1.005	1.005
197.	14	1.000	0.5492	0.9944	0.9974	0.9860	0.0	0.0	0.266	-4.10	49.6	1.005	1.005
207.	15	1.000	0.5480	0.9929	0.9951	0.9887	0.0	0.0	0.267	-4.05	49.6	1.004	1.004
217.	16	0.999	0.5464	0.9915	0.9926	0.9928	0.0	0.0	0.268	-4.00	49.5	1.003	1.003
227.	17	0.998	0.5448	0.9923	0.9922	0.9976	0.0	0.0	0.269	-3.90	49.4	1.001	1.001
237.	18	0.998	0.5435	0.9931	0.9920	1.0018	0.0	0.0	0.271	-3.82	49.3	1.000	1.000
247.	19	0.996	0.5426	0.9942	0.9925	1.0050	0.0	0.0	0.273	-3.73	49.2	0.998	0.998
257.	20	0.998	0.5421	0.9947	0.9926	1.0069	0.0	0.0	0.274	-3.65	49.1	0.996	0.996
267.	21	0.998	0.5419	0.9944	0.9921	1.0081	0.0	0.0	0.275	-3.61	49.1	0.996	0.996
277.	22	0.998	0.5416	0.9947	0.9922	1.0090	0.0	0.0	0.276	-3.56	49.1	0.995	0.995
287.	23	0.998	0.5415	0.9944	0.9918	1.0096	0.0	0.0	0.276	-3.54	49.0	0.994	0.994
297.	24	0.998	0.5413	0.9943	0.9916	1.0100	0.0	0.0	0.277	-3.52	49.0	0.994	0.994
307.	25	0.998	0.5412	0.9943	0.9922	1.0106	0.0	0.0	0.277	-3.51	49.0	0.994	0.994
317.	26	0.999	0.5411	0.9948	0.9929	1.0110	0.0	0.0	0.277	-3.50	49.0	0.994	0.994
327.	27	0.999	0.5410	0.9973	0.9943	1.0116	0.0	0.0	0.277	-3.51	49.0	0.994	0.994
337.	28	0.999	0.5408	0.9990	0.9950	1.0124	0.0	0.0	0.277	-3.52	49.0	0.994	0.994
347.	29	0.999	0.5406	1.0062	0.9969	1.0132	0.0	0.0	0.276	-3.54	49.0	0.994	0.994
357.	30	0.999	0.5405	1.0023	0.9989	1.0141	0.0	0.0	0.276	-3.55	49.1	0.994	0.994
7.	31	0.999	0.5407	1.0045	1.0013	1.0143	0.0	0.0	0.275	-3.56	49.1	0.995	0.995
17.	32	1.000	0.5413	1.0065	1.0037	1.0132	0.0	0.0	0.274	-3.61	49.1	0.996	0.996
27.	33	1.000	0.5423	1.0086	1.0065	1.0108	0.0	0.0	0.273	-3.67	49.2	0.997	0.997
37.	34	1.001	0.5454	1.0094	1.0084	1.0070	0.0	0.0	0.272	-3.74	49.2	0.998	0.998
47.	35	1.002	0.5453	1.0088	1.0089	1.0025	0.0	0.0	0.271	-3.82	49.3	1.000	1.000
57.	36	1.002	0.5465	1.0060	1.0060	0.9986	0.0	0.0	0.269	-3.90	49.4	1.001	1.001

STAGE 14 ROTOR		FLDN SWIRL = 60.43DEG				PARTICLE SWIRL = 141.69DEG				PSAVG = 58.57PSIA = 463857.PA			
		PTAVG = 67.14PSIA = 462941.PA				TIAVG = 1110.90DEG R = 617.2DEG K				VELAVG = 715.1FPS = 218.0MPS			
		RVELAVG = 963.7FPS = 293.7MPS				AXVELAVG = 642.2FPS = 195.0MPS				U = 1033.FPS = 315.2MPS			
THETA	SEG	VEL	NN	PS	PT	TT	WBL	WBL	DF	INCIDENCE	BETA	AXIAL	REL
	NO						LBM/SEC	KG/SEC		IN DEG	IN DEG	VEL	VEL
70.	1	1.003	0.4522	1.0067	1.0081	0.9955	0.0	0.0	0.238	-4.91	41.9	1.003	1.001
80.	2	1.004	0.4531	1.0055	1.0074	0.9933	0.0	0.0	0.237	-4.94	41.9	1.004	1.001
90.	3	1.004	0.4537	1.0044	1.0068	0.9919	0.0	0.0	0.237	-4.97	42.0	1.004	1.001
100.	4	1.005	0.4540	1.0047	1.0072	0.9912	0.0	0.0	0.237	-4.99	42.0	1.005	1.001
110.	5	1.005	0.4543	1.0047	1.0074	0.9907	0.0	0.0	0.237	-5.00	42.0	1.005	1.001
120.	6	1.005	0.4545	1.0042	1.0070	0.9902	0.0	0.0	0.236	-5.01	42.0	1.005	1.001
130.	7	1.005	0.4546	1.0042	1.0071	0.9899	0.0	0.0	0.236	-5.01	42.0	1.005	1.001
140.	8	1.005	0.4548	1.0043	1.0073	0.9897	0.0	0.0	0.236	-5.02	42.0	1.005	1.001
150.	9	1.005	0.4549	1.0014	1.0045	0.9885	0.0	0.0	0.237	-5.01	42.0	1.005	1.001
160.	10	1.005	0.4550	1.0002	1.0034	0.9874	0.0	0.0	0.237	-5.00	42.0	1.005	1.001
170.	11	1.005	0.4552	1.0007	1.0040	0.9854	0.0	0.0	0.237	-5.00	42.0	1.005	1.001
180.	12	1.005	0.4555	0.9990	1.0024	0.9834	0.0	0.0	0.237	-5.00	42.0	1.005	1.001
190.	13	1.005	0.4556	0.9969	1.0004	0.9850	0.0	0.0	0.237	-5.00	42.0	1.005	1.001
200.	14	1.005	0.4551	0.9949	0.9981	0.9866	0.0	0.0	0.239	-4.98	42.0	1.005	1.001
210.	15	1.004	0.4541	0.9933	0.9959	0.9887	0.0	0.0	0.240	-4.95	41.9	1.004	1.001
220.	16	1.003	0.4528	0.9917	0.9934	0.9926	0.0	0.0	0.242	-4.91	41.9	1.003	1.001
230.	17	1.001	0.4509	0.9923	0.9929	0.9976	0.0	0.0	0.244	-4.84	41.8	1.001	1.000
240.	18	1.000	0.4495	0.9929	0.9925	1.0018	0.0	0.0	0.246	-4.78	41.8	1.000	1.000
250.	19	0.998	0.4478	0.9940	0.9927	1.0050	0.0	0.0	0.247	-4.71	41.7	0.998	1.000
260.	20	0.996	0.4467	0.9946	0.9926	1.0069	0.0	0.0	0.249	-4.65	41.7	0.996	0.999
270.	21	0.996	0.4460	0.9943	0.9920	1.0081	0.0	0.0	0.249	-4.62	41.6	0.996	0.999
280.	22	0.995	0.4454	0.9946	0.9919	1.0090	0.0	0.0	0.250	-4.58	41.6	0.995	0.999
290.	23	0.994	0.4451	0.9943	0.9915	1.0096	0.0	0.0	0.250	-4.56	41.6	0.994	0.999
300.	24	0.994	0.4448	0.9943	0.9917	1.0100	0.0	0.0	0.251	-4.54	41.5	0.994	0.999
310.	25	0.994	0.4446	0.9949	0.9917	1.0106	0.0	0.0	0.251	-4.54	41.5	0.994	0.999
320.	26	0.994	0.4445	0.9957	0.9925	1.0110	0.0	0.0	0.251	-4.54	41.5	0.994	0.999
330.	27	0.994	0.4444	0.9972	0.9939	1.0116	0.0	0.0	0.251	-4.54	41.5	0.994	0.999
340.	28	0.994	0.4444	0.9987	0.9954	1.0124	0.0	0.0	0.250	-4.55	41.6	0.994	0.999
350.	29	0.995	0.4444	0.9998	0.9965	1.0132	0.0	0.0	0.249	-4.57	41.6	0.995	0.999
0.	30	0.995	0.4444	1.0018	0.9984	1.0141	0.0	0.0	0.249	-4.59	41.6	0.995	0.999
10.	31	0.996	0.4447	1.0039	1.0007	1.0143	0.0	0.0	0.247	-4.61	41.6	0.996	0.999
20.	32	0.996	0.4452	1.0059	1.0030	1.0132	0.0	0.0	0.246	-4.64	41.6	0.996	0.999
30.	33	0.997	0.4462	1.0081	1.0058	1.0108	0.0	0.0	0.244	-4.68	41.7	0.997	0.999
40.	34	0.999	0.4476	1.0091	1.0077	1.0070	0.0	0.0	0.242	-4.74	41.7	0.999	1.000
50.	35	1.000	0.4493	1.0087	1.0083	1.0025	0.0	0.0	0.240	-4.79	41.8	1.000	1.000
60.	36	1.001	0.4508	1.0060	1.0086	0.9986	0.0	0.0	0.239	-4.85	41.8	1.001	1.000

APPENDIX B (Cont'd)

STATOR

FLOW SWIRL= 61.50DEG PARTICLE SWIRL=147.10DEG PSAVE= 62.13PSIA = 428395.PA
 PTAVG= 74.93PSIA = 516614.PA TTAVG=1161.0DEG R = 645.0DEG K VELAVG= 853.3FPS = 260.1MPS
 RVELAVG= 826.5FPS = 251.9MPS AXVELAVG= 660.5FPS = 201.3MPS U=1037.FPS = 316.MPS

THETA	SEG NO	VEL	MM	PS	PT	TT	NBL LBM/SEC	NBL KG/SEC	DF	INCIDENCE IN DEG	BETA IN DEG	AXIAL IN DEG	REL VEL
72.	1	1.002	0.5314	1.0058	1.0074	0.9966	0.0	0.0	0.281	-5.48	51.0	1.005	1.005
82.	2	1.002	0.5319	1.0047	1.0066	0.9960	0.0	0.0	0.281	-5.50	51.0	1.005	1.005
92.	3	1.002	0.5323	1.0037	1.0059	0.9924	0.0	0.0	0.281	-5.52	51.0	1.005	1.005
102.	4	1.002	0.5324	1.0040	1.0062	0.9916	0.0	0.0	0.281	-5.54	51.0	1.006	1.006
112.	5	1.002	0.5325	1.0041	1.0064	0.9910	0.0	0.0	0.280	-5.54	51.0	1.006	1.006
122.	6	1.002	0.5327	1.0035	1.0060	0.9910	0.0	0.0	0.280	-5.55	51.0	1.006	1.006
132.	7	1.002	0.5328	1.0036	1.0061	0.9904	0.0	0.0	0.280	-5.56	51.1	1.006	1.006
142.	8	1.002	0.5328	1.0037	1.0062	0.9898	0.0	0.0	0.280	-5.57	51.1	1.006	1.006
152.	9	1.001	0.5330	1.0011	1.0038	0.9888	0.0	0.0	0.281	-5.54	51.0	1.006	1.006
162.	10	1.001	0.5333	1.0062	1.0031	0.9880	0.0	0.0	0.281	-5.53	51.0	1.006	1.006
172.	11	1.002	0.5335	1.0067	1.0038	0.9873	0.0	0.0	0.281	-5.53	51.0	1.006	1.006
182.	12	1.002	0.5338	0.9990	1.0023	0.9861	0.0	0.0	0.281	-5.53	51.0	1.006	1.006
192.	13	1.001	0.5338	0.9971	1.0003	0.9853	0.0	0.0	0.282	-5.50	51.0	1.005	1.005
202.	14	1.000	0.5233	0.9953	0.9911	0.9857	0.0	0.0	0.283	-5.44	50.9	1.004	1.004
212.	15	0.999	0.5222	0.9937	0.9858	0.9877	0.0	0.0	0.285	-5.35	50.9	1.002	1.002
222.	16	0.999	0.5208	0.9920	0.9831	0.9911	0.0	0.0	0.286	-5.27	50.8	1.001	1.001
232.	17	0.998	0.5292	0.9927	0.9827	0.9957	0.0	0.0	0.286	-5.17	50.7	0.999	0.999
242.	18	0.998	0.5260	0.9934	0.9925	1.0001	0.0	0.0	0.289	-5.10	50.6	0.998	0.998
252.	19	0.998	0.5270	0.9947	0.9932	1.0037	0.0	0.0	0.290	-5.02	50.5	0.996	0.996
262.	20	0.998	0.5264	0.9955	0.9935	1.0062	0.0	0.0	0.291	-4.95	50.4	0.995	0.995
272.	21	0.998	0.5262	0.9951	0.9929	1.0076	0.0	0.0	0.292	-4.92	50.4	0.994	0.994
282.	22	0.998	0.5258	0.9956	0.9932	1.0087	0.0	0.0	0.293	-4.87	50.4	0.993	0.993
292.	23	0.998	0.5257	0.9952	0.9927	1.0093	0.0	0.0	0.293	-4.86	50.4	0.993	0.993
302.	24	0.998	0.5255	0.9953	0.9927	1.0099	0.0	0.0	0.293	-4.83	50.3	0.993	0.993
312.	25	0.998	0.5255	0.9950	0.9931	1.0104	0.0	0.0	0.293	-4.83	50.3	0.993	0.993
322.	26	0.998	0.5254	0.9965	0.9938	1.0109	0.0	0.0	0.293	-4.83	50.3	0.993	0.993
332.	27	0.998	0.5253	0.9978	0.9950	1.0115	0.0	0.0	0.293	-4.85	50.3	0.993	0.993
342.	28	0.998	0.5252	0.9991	0.9962	1.0121	0.0	0.0	0.292	-4.87	50.4	0.993	0.993
352.	29	0.999	0.5250	0.9999	0.9969	1.0128	0.0	0.0	0.292	-4.90	50.4	0.994	0.994
2.	30	0.999	0.5249	1.0017	0.9986	1.0136	0.0	0.0	0.291	-4.93	50.4	0.995	0.995
12.	31	0.999	0.5251	1.0035	1.0005	1.0140	0.0	0.0	0.290	-5.00	50.5	0.996	0.996
22.	32	1.000	0.5256	1.0054	1.0027	1.0135	0.0	0.0	0.289	-5.06	50.6	0.997	0.997
32.	33	1.001	0.5266	1.0074	1.0054	1.0117	0.0	0.0	0.287	-5.16	50.7	0.999	0.999
42.	34	1.002	0.5279	1.0082	1.0073	1.0084	0.0	0.0	0.285	-5.27	50.8	1.001	1.001
52.	35	1.002	0.5293	1.0079	1.0079	1.0042	0.0	0.0	0.283	-5.35	50.8	1.002	1.002
62.	36	1.002	0.5305	1.0072	1.0081	1.0000	0.0	0.0	0.282	-5.41	50.9	1.004	1.004

STAGE 15 ROTOR

FLOW SWIRL= 64.26DEG PARTICLE SWIRL=149.86DEG PSAVE= 66.81PSIA = 440701.PA
 PTAVG= 75.75PSIA = 522248.PA TTAVG=1161.0DEG R = 645.0DEG K VELAVG= 701.1FPS = 213.7MPS
 RVELAVG=1005.0FPS = 306.3MPS AXVELAVG= 646.7FPS = 197.1MPS U=1046.FPS = 317.MPS

THETA	SEG NO	VEL	MM	PS	PT	TT	NBL LBM/SEC	NBL KG/SEC	DF	INCIDENCE IN DEG	BETA IN DEG	AXIAL IN DEG	REL VEL
74.	1	1.005	0.4342	1.0055	1.0072	0.9966	0.0	0.0	0.235	-6.34	40.2	1.005	1.001
84.	2	1.005	0.4349	1.0045	1.0066	0.9940	0.0	0.0	0.235	-6.36	40.3	1.005	1.001
94.	3	1.006	0.4354	1.0036	1.0060	0.9924	0.0	0.0	0.235	-6.37	40.3	1.006	1.001
104.	4	1.006	0.4357	1.0039	1.0064	0.9916	0.0	0.0	0.235	-6.38	40.3	1.006	1.001
114.	5	1.006	0.4358	1.0040	1.0067	0.9910	0.0	0.0	0.235	-6.38	40.3	1.006	1.001
124.	6	1.006	0.4360	1.0035	1.0063	0.9904	0.0	0.0	0.235	-6.38	40.3	1.006	1.001
134.	7	1.006	0.4361	1.0035	1.0064	0.9901	0.0	0.0	0.235	-6.39	40.3	1.006	1.001
144.	8	1.006	0.4363	1.0036	1.0065	0.9898	0.0	0.0	0.235	-6.40	40.3	1.006	1.001
154.	9	1.006	0.4362	1.0012	1.0041	0.9888	0.0	0.0	0.236	-6.37	40.3	1.006	1.001
164.	10	1.005	0.4362	1.0004	1.0033	0.9880	0.0	0.0	0.236	-6.36	40.3	1.005	1.001
174.	11	1.005	0.4364	1.0010	1.0040	0.9873	0.0	0.0	0.236	-6.36	40.3	1.005	1.001
184.	12	1.005	0.4366	0.9995	1.0026	0.9861	0.0	0.0	0.237	-6.35	40.3	1.005	1.001
194.	13	1.005	0.4365	0.9976	1.0007	0.9853	0.0	0.0	0.238	-6.33	40.2	1.005	1.001
204.	14	1.003	0.4358	0.9959	0.9986	0.9857	0.0	0.0	0.240	-6.28	40.2	1.003	1.001
214.	15	1.002	0.4346	0.9944	0.9964	0.9877	0.0	0.0	0.243	-6.21	40.1	1.002	1.000
224.	16	1.000	0.4332	0.9926	0.9937	0.9911	0.0	0.0	0.245	-6.16	40.1	1.000	1.000
234.	17	0.998	0.4314	0.9932	0.9933	0.9957	0.0	0.0	0.248	-6.09	40.0	0.998	1.000
244.	18	0.997	0.4300	0.9937	0.9929	1.0001	0.0	0.0	0.249	-6.05	39.9	0.997	0.999
254.	19	0.996	0.4286	0.9949	0.9934	1.0037	0.0	0.0	0.250	-5.99	39.9	0.996	0.999
264.	20	0.995	0.4275	0.9957	0.9935	1.0062	0.0	0.0	0.251	-5.95	39.8	0.995	0.999
274.	21	0.994	0.4270	0.9953	0.9928	1.0076	0.0	0.0	0.251	-5.93	39.8	0.994	0.999
284.	22	0.993	0.4264	0.9958	0.9930	1.0087	0.0	0.0	0.252	-5.89	39.8	0.993	0.999
294.	23	0.993	0.4262	0.9954	0.9925	1.0093	0.0	0.0	0.252	-5.89	39.8	0.993	0.999
304.	24	0.993	0.4258	0.9955	0.9924	1.0099	0.0	0.0	0.253	-5.87	39.8	0.993	0.999
314.	25	0.993	0.4257	0.9959	0.9928	1.0104	0.0	0.0	0.252	-5.87	39.8	0.993	0.999
324.	26	0.993	0.4257	0.9966	0.9934	1.0109	0.0	0.0	0.252	-5.87	39.8	0.993	0.999
334.	27	0.993	0.4257	0.9979	0.9946	1.0115	0.0	0.0	0.252	-5.88	39.8	0.993	0.999
344.	28	0.994	0.4258	0.9990	0.9958	1.0121	0.0	0.0	0.251	-5.80	39.8	0.994	0.999
354.	29	0.994	0.4259	0.9997	0.9966	1.0128	0.0	0.0	0.250	-5.83	39.8	0.994	0.999
4.	30	0.995	0.4261	1.0013	0.9982	1.0136	0.0	0.0	0.249	-5.86	39.9	0.995	0.999
14.	31	0.996	0.4266	1.0029	1.0002	1.0140	0.0	0.0	0.246	-6.01	39.9	0.996	0.999
24.	32	0.998	0.4273	1.0047	1.0023	1.0135	0.0	0.0	0.244	-6.06	40.0	0.998	1.000
34.	33	0.999	0.4285	1.0066	1.0050	1.0117	0.0	0.0	0.241	-6.13	40.0	0.999	1.000
44.	34	1.001	0.4301	1.0075	1.0067	1.0084	0.0	0.0	0.238	-6.21	40.1	1.001	1.000
54.	35	1.003	0.4316	1.0073	1.0074	1.0042	0.0	0.0	0.236	-6.26	40.2	1.003	1.001
64.	36	1.004	0.4330	1.0068	1.0078	1.0000	0.0	0.0	0.235	-6.36	40.2	1.004	1.001

APPENDIX B (Cont'd)

STATOR		FLOW SWIRL= 64.370 DEG					PARTICLE SWIRL=153.46 DEG					PSAVG= 72.54PSIA = 500152. PA				
		PTAVG= 84.89FPS = 585316. PA					TTAVG=1206.70 DEG R = 670.4 DEG K					VELAVG= 798.8FPS = 243.5MPS				
		RVELAVG= 853.9FPS = 260.3MPS					ANVELAVG= 640.2FPS = 195.1MPS					U=1043.FPS = 318.MPS				
THETA	SEG NO	VEL	MN	PS	PT	TT	WBL LBN/SEC	MBL KG/SEC	DF	INCIDENCE IN DEG	ALPHA IN DEG	AXIAL VEL	REL VEL			
74.	1	1.003	0.4865	1.0037	1.0050	0.9973	0.0	0.0	0.251	-6.12	53.7	1.008	1.008			
84.	2	1.002	0.4869	1.0032	1.0048	0.9946	0.0	0.0	0.251	-6.11	53.7	1.007	1.007			
94.	3	1.002	0.4872	1.0024	1.0062	0.9927	0.0	0.0	0.251	-6.10	53.7	1.007	1.007			
104.	4	1.002	0.4874	1.0027	1.0047	0.9918	0.0	0.0	0.251	-6.10	53.7	1.007	1.007			
114.	5	1.002	0.4875	1.0029	1.0049	0.9911	0.0	0.0	0.251	-6.10	53.7	1.007	1.007			
124.	6	1.002	0.4876	1.0025	1.0046	0.9905	0.0	0.0	0.251	-6.10	53.7	1.007	1.007			
134.	7	1.002	0.4877	1.0025	1.0047	0.9902	0.0	0.0	0.251	-6.11	53.7	1.007	1.007			
144.	8	1.002	0.4878	1.0025	1.0047	0.9899	0.0	0.0	0.251	-6.12	53.7	1.008	1.008			
154.	9	1.001	0.4878	1.0067	1.0029	0.9890	0.0	0.0	0.252	-6.06	53.7	1.007	1.007			
164.	10	1.001	0.4880	1.0060	1.0025	0.9883	0.0	0.0	0.252	-6.03	53.6	1.006	1.006			
174.	11	1.002	0.4882	1.0006	1.0033	0.9877	0.0	0.0	0.252	-6.04	53.6	1.006	1.006			
184.	12	1.001	0.4884	0.9994	1.0021	0.9866	0.0	0.0	0.252	-6.02	53.6	1.006	1.006			
194.	13	1.001	0.4884	0.9981	1.0007	0.9858	0.0	0.6	0.254	-5.95	53.5	1.005	1.005			
204.	14	1.000	0.4878	0.9971	0.9994	0.9859	0.0	0.0	0.256	-5.81	53.4	1.002	1.002			
214.	15	0.999	0.4869	0.9962	0.9978	0.9874	0.0	0.0	0.259	-5.65	53.3	1.000	1.000			
224.	16	0.998	0.4859	0.9943	0.9952	0.9902	0.0	0.0	0.261	-5.54	53.1	0.998	0.998			
234.	17	0.997	0.4844	0.9951	0.9951	0.9946	0.0	0.0	0.264	-5.40	53.0	0.996	0.996			
244.	18	0.997	0.4834	0.9951	0.9945	0.9929	0.0	0.0	0.265	-5.35	52.9	0.995	0.995			
254.	19	0.997	0.4824	0.9965	0.9952	1.0028	0.0	0.0	0.266	-5.27	52.9	0.993	0.993			
264.	20	0.997	0.4818	0.9973	0.9956	1.0056	0.0	0.0	0.267	-5.21	52.8	0.992	0.992			
274.	21	0.998	0.4816	0.9966	0.9947	1.0072	0.0	0.0	0.267	-5.22	52.8	0.992	0.992			
284.	22	0.998	0.4812	0.9973	0.9946	1.0085	0.0	0.0	0.268	-5.16	52.8	0.992	0.992			
294.	23	0.996	0.4812	0.9967	0.9946	1.0092	0.0	0.0	0.268	-5.14	52.8	0.991	0.991			
304.	24	0.998	0.4809	0.9971	0.9948	1.0098	0.0	0.0	0.269	-5.15	52.8	0.991	0.991			
314.	25	0.998	0.4809	0.9972	0.9949	1.0104	0.0	0.0	0.268	-5.14	52.8	0.991	0.991			
324.	26	0.998	0.4809	0.9978	0.9954	1.0109	0.0	0.0	0.268	-5.15	52.8	0.991	0.991			
334.	27	0.998	0.4808	0.9986	0.9944	1.0114	0.0	0.0	0.267	-5.18	52.8	0.992	0.992			
344.	28	0.998	0.4808	0.9995	0.9971	1.0119	0.0	0.0	0.267	-5.23	52.8	0.993	0.993			
354.	29	0.999	0.4808	0.9998	0.9974	1.0124	0.0	0.0	0.266	-5.28	52.9	0.994	0.994			
4.	30	0.999	0.4807	1.0010	0.9986	1.0132	0.0	0.0	0.264	-5.35	52.9	0.995	0.995			
14.	31	1.000	0.4810	1.0019	0.9996	1.0136	0.0	0.0	0.262	-5.47	53.1	0.997	0.997			
24.	32	1.000	0.4814	1.0033	1.0012	1.0134	0.0	0.0	0.260	-5.59	53.2	0.999	0.999			
34.	33	1.001	0.4822	1.0047	1.0032	1.0120	0.0	0.0	0.257	-5.76	53.4	1.001	1.001			
44.	34	1.002	0.4834	1.0051	1.0043	1.0090	0.0	0.0	0.254	-5.93	53.5	1.004	1.004			
54.	35	1.003	0.4846	1.0052	1.0052	1.0051	0.0	0.0	0.252	-6.02	53.6	1.006	1.006			
64.	36	1.003	0.4856	1.0049	1.0056	1.0010	0.0	0.0	0.251	-6.08	53.7	1.007	1.007			

STAGE 16 ROTOR		FLOW SWIRL= 66.69 DEG					PARTICLE SWIRL=155.70 DEG					PSAVG= 75.20PSIA = 510493. PA				
		PTAVG= 84.12PSIA = 500006. PA					TTAVG=1206.70 DEG R = 670.4 DEG K					VELAVG= 676.5FPS = 206.2MPS				
		RVELAVG=1047.1FPS = 319.1MPS					ANVELAVG= 640.8FPS = 195.3MPS					U=1045.FPS = 319.MPS				
THETA	SEG NO	VEL	MN	PS	PT	TT	WBL LBN/SEC	MBL KG/SEC	DF	INCIDENCE IN DEG	BETA IN DEG	AXIAL VEL	REL VEL			
77.	1	1.008	0.4117	1.0030	1.0051	0.9973	0.0	0.0	0.259	-5.82	38.0	1.008	1.002			
87.	2	1.008	0.4122	1.0025	1.0049	0.9946	0.0	0.0	0.260	-5.61	38.0	1.008	1.002			
97.	3	1.008	0.4125	1.0018	1.0044	0.9927	0.0	0.0	0.261	-5.81	38.0	1.008	1.002			
107.	4	1.006	0.4127	1.0021	1.0048	0.9918	0.0	0.0	0.261	-5.81	38.0	1.008	1.002			
117.	5	1.006	0.4129	1.0023	1.0051	0.9911	0.0	0.0	0.261	-5.81	38.0	1.008	1.002			
127.	6	1.006	0.4130	1.0018	1.0047	0.9905	0.0	0.0	0.261	-5.81	38.0	1.008	1.002			
137.	7	1.006	0.4131	1.0019	1.0048	0.9902	0.0	0.0	0.261	-5.81	38.0	1.008	1.002			
147.	8	1.008	0.4133	1.0018	1.0048	0.9899	0.0	0.0	0.261	-5.82	38.0	1.006	1.002			
157.	9	1.007	0.4130	1.0001	1.0030	0.9890	0.0	0.0	0.263	-5.78	38.0	1.007	1.002			
167.	10	1.007	0.4129	0.9997	1.0025	0.9883	0.0	0.0	0.263	-5.76	38.0	1.007	1.001			
177.	11	1.007	0.4130	1.0003	1.0032	0.9877	0.0	0.0	0.263	-5.77	38.0	1.007	1.001			
187.	12	1.006	0.4132	0.9989	1.0019	0.9866	0.0	0.0	0.263	-5.76	38.0	1.006	1.001			
197.	13	1.005	0.4128	0.9977	1.0005	0.9858	0.0	0.0	0.265	-5.71	37.9	1.005	1.001			
207.	14	1.003	0.4117	0.9970	0.9992	0.9859	0.0	0.0	0.269	-5.62	37.8	1.003	1.001			
217.	15	1.000	0.4101	0.9963	0.9976	0.9874	0.0	0.0	0.274	-5.52	37.7	1.000	1.000			
227.	16	0.998	0.4087	0.9945	0.9951	0.9902	0.0	0.0	0.277	-5.45	37.6	0.998	0.999			
237.	17	0.995	0.4068	0.9956	0.9950	0.9946	0.0	0.0	0.280	-5.36	37.6	0.995	0.999			
247.	18	0.994	0.4055	0.9957	0.9944	0.9949	0.0	0.0	0.280	-5.33	37.5	0.994	0.999			
257.	19	0.993	0.4042	0.9971	0.9952	1.0028	0.0	0.0	0.281	-5.28	37.5	0.993	0.999			
267.	20	0.992	0.4032	0.9960	0.9955	1.0056	0.0	0.0	0.282	-5.25	37.4	0.992	0.998			
277.	21	0.992	0.4029	0.9973	0.9944	1.0072	0.0	0.0	0.281	-5.25	37.4	0.992	0.998			
287.	22	0.991	0.4022	0.9981	0.9951	1.0085	0.0	0.0	0.282	-5.21	37.4	0.991	0.998			
297.	23	0.991	0.4021	0.9975	0.9944	1.0092	0.0	0.0	0.282	-5.21	37.4	0.991	0.998			
307.	24	0.990	0.4017	0.9979	0.9946	1.0098	0.0	0.0	0.283	-5.19	37.4	0.990	0.998			
317.	25	0.991	0.4016	0.9979	0.9946	1.0104	0.0	0.0	0.282	-5.20	37.4	0.991	0.998			
327.	26	0.991	0.4017	0.9985	0.9952	1.0109	0.0	0.0	0.281	-5.21	37.4	0.991	0.998			
337.	27	0.991	0.4019	0.9995	0.9962	1.0114	0.0	0.0	0.281	-5.23	37.4	0.991	0.998			
347.	28	0.992	0.4021	1.0002	0.9970	1.0119	0.0	0.0	0.279	-5.26	37.5	0.992	0.998			
357.	29	0.993	0.4024	1.0004	0.9974	1.0124	0.0	0.0	0.278	-5.29	37.5	0.993	0.999			
7.	30	0.994	0.4027	1.0015	0.9987	1.0122	0.0	0.0	0.277	-5.33	37.5	0.994	0.999			
17.	31	0.997	0.4030	1.0022	0.9998	1.0136	0.0	0.0	0.273	-5.41	37.6	0.997	0.999			
27.	32	0.999	0.4046	1.0033	1.0015	1.0134	0.0	0.0	0.270	-5.49	37.7	0.999	1.000			
37.	33	1.002	0.4061	1.0045	1.0035	1.0120	0.0	0.0	0.266	-5.59	37.8	1.002	1.000			
47.	34	1.005	0.4079	1.0046	1.0046	1.0090	0.0	0.0	0.262	-5.70	37.9	1.005	1.001			
57.	35	1.006	0.4054	1.0046	1.0054	1.0051	0.0	0.0	0.260	-5.76	38.0	1.006	1.001			
67.	36	1.007	0.4107	1.0042	1.0056	1.0010	0.0	0.0	0.259	-5.79	38.0	1.007	1.002			

APPENDIX B (Cont'd)

STATOR		FLOW SWIRL= 86.68DEG						PARTICLE SWIRL=160.04DEG						PSAVG= 79.72PSIA = 549632.PA					
		PTAVG= 92.12PSIA = 635136.PA						TTAVG=1252.2DEG R = 695.6DEG K						VELAVG= 781.0FPS = 238.OMPS					
		RVELAVG= 876.4FPS = 267.1MPS						AXVELAVG= 639.9FPS =195.0MPS						U=1047.FPS = 319.MPS					
THETA	SEG NO	VEL	NN	PS	PT	TT	MBL LBM/SEC	MBL KG/SEC	DF	INCIDENCE IN DEG	ALPHA IN DEG	AXIAL VEL	REL VEL						
77.	1	1.004	0.4669	1.0010	1.0024	0.9981	0.0	0.0	0.321	-12.81	55.7	1.011	1.011						
87.	2	1.003	0.4671	1.0014	1.0030	0.9953	0.0	0.0	0.323	-12.73	55.6	1.010	1.010						
97.	3	1.003	0.4674	1.0008	1.0026	0.9932	0.0	0.0	0.324	-12.70	55.6	1.009	1.009						
107.	4	1.002	0.4676	1.0011	1.0030	0.9920	0.0	0.0	0.324	-12.69	55.6	1.009	1.009						
117.	5	1.002	0.4677	1.0013	1.0033	0.9912	0.0	0.0	0.324	-12.66	55.6	1.009	1.009						
127.	6	1.002	0.4678	1.0010	1.0030	0.9905	0.0	0.0	0.324	-12.67	55.6	1.009	1.009						
137.	7	1.002	0.4679	1.0009	1.0031	0.9901	0.0	0.0	0.324	-12.67	55.6	1.009	1.009						
147.	8	1.002	0.4681	1.0007	1.0029	0.9898	0.0	0.0	0.324	-12.70	55.6	1.009	1.009						
157.	9	1.002	0.4678	1.0001	1.0021	0.9892	0.0	0.0	0.326	-12.58	55.5	1.007	1.007						
167.	10	1.002	0.4679	0.9996	1.0018	0.9886	0.0	0.0	0.326	-12.55	55.5	1.007	1.007						
177.	11	1.002	0.4683	0.9998	1.0022	0.9881	0.0	0.0	0.326	-12.59	55.5	1.007	1.007						
187.	12	1.002	0.4684	0.9988	1.0013	0.9870	0.0	0.0	0.326	-12.56	55.5	1.007	1.007						
197.	13	1.001	0.4681	0.9985	1.0008	0.9863	0.0	0.0	0.328	-12.42	55.3	1.005	1.005						
207.	14	0.999	0.4674	0.9989	1.0007	0.9863	0.0	0.0	0.332	-12.19	55.1	1.001	1.001						
217.	15	0.996	0.4664	0.9969	1.0001	0.9875	0.0	0.0	0.335	-11.94	54.8	0.997	0.997						
227.	16	0.997	0.4655	0.9970	0.9970	0.9896	0.0	0.0	0.334	-11.77	54.7	0.995	0.995						
237.	17	0.994	0.4641	0.9983	0.9980	0.9936	0.0	0.0	0.340	-11.58	54.5	0.992	0.992						
247.	18	0.996	0.4653	0.9975	0.9967	0.9977	0.0	0.0	0.340	-11.56	54.5	0.991	0.991						
257.	19	0.996	0.4623	0.9990	0.9976	1.0018	0.0	0.0	0.341	-11.49	54.4	0.990	0.990						
267.	20	0.996	0.4617	0.9997	0.9979	1.0050	0.0	0.0	0.341	-11.45	54.4	0.989	0.989						
277.	21	0.997	0.4617	0.9984	0.9965	1.0067	0.0	0.0	0.340	-11.50	54.4	0.989	0.989						
287.	22	0.997	0.4611	0.9998	0.9976	1.0084	0.0	0.0	0.341	-11.43	54.3	0.989	0.989						
297.	23	0.997	0.4612	0.9987	0.9965	1.0091	0.0	0.0	0.341	-11.46	54.4	0.990	0.990						
307.	24	0.997	0.4608	0.9995	0.9971	1.0100	0.0	0.0	0.341	-11.40	54.3	0.989	0.989						
317.	25	0.998	0.4610	0.9989	0.9966	1.0104	0.0	0.0	0.340	-11.46	54.4	0.990	0.990						
327.	26	0.998	0.4609	0.9995	0.9972	1.0110	0.0	0.0	0.340	-11.48	54.4	0.990	0.990						
337.	27	0.998	0.4609	1.0001	0.9978	1.0114	0.0	0.0	0.339	-11.52	54.4	0.991	0.991						
347.	28	0.998	0.4610	1.0004	0.9982	1.0118	0.0	0.0	0.338	-11.60	54.5	0.992	0.992						
357.	29	0.999	0.4611	1.0003	0.9981	1.0122	0.0	0.0	0.337	-11.67	54.6	0.993	0.993						
7.	30	0.999	0.4611	1.0011	0.9989	1.0128	0.0	0.0	0.336	-11.75	54.7	0.994	0.994						
17.	31	1.000	0.4616	1.0007	0.9988	1.0131	0.0	0.0	0.333	-11.95	54.8	0.997	0.997						
27.	32	1.001	0.4620	1.0015	0.9998	1.0130	0.0	0.0	0.331	-12.12	55.0	1.000	1.000						
37.	33	1.002	0.4630	1.0018	1.0007	1.0119	0.0	0.0	0.327	-12.38	55.3	1.004	1.004						
47.	34	1.004	0.4643	1.0013	1.0010	1.0093	0.0	0.0	0.323	-12.64	55.5	1.008	1.008						
57.	35	1.004	0.4651	1.0019	1.0022	1.0059	0.0	0.0	0.322	-12.73	55.6	1.010	1.010						
67.	36	1.004	0.4661	1.0020	1.0029	1.0020	0.0	0.0	0.322	-12.78	55.7	1.011	1.011						

EXIT		FLOW SWIRL= 64.50DEG						PARTICLE SWIRL=161.86DEG						PSAVG= 84.90PSIA = 599132.PA					
		PTAVG= 95.00PSIA = 655012.PA						TTAVG=1252.2DEG R = 695.6DEG K						VELAVG= 615.3FPS =187.6MPS					
		RVELAVG= 0.0FPS = 0.0MPS						AXVELAVG= 0.0FPS = 0.0MPS						U=1047.FPS = 319.MPS					
THETA	SEG NO	VEL	NN	PS	PT	TT	MBL LBM/SEC	MBL KG/SEC	DF	INCIDENCE IN DEG	ALPHA IN DEG	AXIAL VEL	REL VEL						
78.	1	1.012	0.3684	0.9995	1.0019	0.9981	0.0	0.0	0.0	0.0	0.0	0.0	0.0						
88.	2	1.011	0.3683	1.0004	1.0027	0.9953	0.0	0.0	0.0	0.0	0.0	0.0	0.0						
98.	3	1.010	0.3683	1.0001	1.0025	0.9932	0.0	0.0	0.0	0.0	0.0	0.0	0.0						
108.	4	1.010	0.3685	1.0005	1.0030	0.9920	0.0	0.0	0.0	0.0	0.0	0.0	0.0						
118.	5	1.009	0.3685	1.0009	1.0034	0.9912	0.0	0.0	0.0	0.0	0.0	0.0	0.0						
128.	6	1.009	0.3685	1.0006	1.0031	0.9905	0.0	0.0	0.0	0.0	0.0	0.0	0.0						
138.	7	1.009	0.3686	1.0006	1.0032	0.9901	0.0	0.0	0.0	0.0	0.0	0.0	0.0						
148.	8	1.010	0.3688	1.0004	1.0030	0.9896	0.0	0.0	0.0	0.0	0.0	0.0	0.0						
158.	9	1.007	0.3681	1.0001	1.0024	0.9892	0.0	0.0	0.0	0.0	0.0	0.0	0.0						
168.	10	1.007	0.3680	0.9998	1.0021	0.9886	0.0	0.0	0.0	0.0	0.0	0.0	0.0						
178.	11	1.007	0.3683	1.0000	1.0024	0.9881	0.0	0.0	0.0	0.0	0.0	0.0	0.0						
188.	12	1.007	0.3682	0.9992	1.0018	0.9870	0.0	0.0	0.0	0.0	0.0	0.0	0.0						
198.	13	1.004	0.3674	0.9993	1.0013	0.9863	0.0	0.0	0.0	0.0	0.0	0.0	0.0						
208.	14	1.000	0.3658	1.0003	1.0015	0.9863	0.0	0.0	0.0	0.0	0.0	0.0	0.0						
218.	15	0.995	0.3640	1.0008	1.0011	0.9875	0.0	0.0	0.0	0.0	0.0	0.0	0.0						
228.	16	0.995	0.3626	0.9990	0.9986	0.9896	0.0	0.0	0.0	0.0	0.0	0.0	0.0						
238.	17	0.990	0.3607	1.0003	0.9989	0.9936	0.0	0.0	0.0	0.0	0.0	0.0	0.0						
248.	18	0.990	0.3600	0.9991	0.9974	0.9977	0.0	0.0	0.0	0.0	0.0	0.0	0.0						
258.	19	0.989	0.3590	1.0002	0.9961	1.0018	0.0	0.0	0.0	0.0	0.0	0.0	0.0						
268.	20	0.989	0.3583	1.0007	0.9982	1.0050	0.0	0.0	0.0	0.0	0.0	0.0	0.0						
278.	21	0.990	0.3584	0.9991	0.9966	1.0067	0.0	0.0	0.0	0.0	0.0	0.0	0.0						
288.	22	0.988	0.3577	1.0004	0.9976	1.0084	0.0	0.0	0.0	0.0	0.0	0.0	0.0						
298.	23	0.989	0.3578	0.9992	0.9965	1.0091	0.0	0.0	0.0	0.0	0.0	0.0	0.0						
308.	24	0.988	0.3573	1.0001	0.9970	1.0100	0.0	0.0	0.0	0.0	0.0	0.0	0.0						
318.	25	0.989	0.3576	0.9993	0.9964	1.0104	0.0	0.0	0.0	0.0	0.0	0.0	0.0						
328.	26	0.990	0.3576	0.9998	0.9969	1.0110	0.0	0.0	0.0	0.0	0.0	0.0	0.0						
338.	27	0.990	0.3579	1.0003	0.9975	1.0114	0.0	0.0	0.0	0.0	0.0	0.0	0.0						
348.	28	0.992	0.3563	1.0004	0.9978	1.0118	0.0	0.0	0.0	0.0	0.0	0.0	0.0						
358.	29	0.993	0.3587	1.0001	0.9978	1.0122	0.0	0.0	0.0	0.0	0.0	0.0	0.0						
8.	30	0.995	0.3592	1.0006	0.9985	1.0128	0.0	0.0	0.0	0.0	0.0	0.0	0.0						
18.	31	0.998	0.3605	0.9998	0.9983	1.0131	0.0	0.0	0.0	0.0	0.0	0.0	0.0						
28.	32	1.001	0.3616	1.0001	0.9992	1.0130	0.0	0.0	0.0	0.0	0.0	0.0	0.0						
38.	33	1.006	0.3635	0.9999	0.9999	1.0119	0.0	0.0	0.0	0.0	0.0	0.0	0.0						
48.	34	1.010	0.3658	0.9990	1.0000	1.0093	0.0	0.0	0.0	0.0	0.0	0.0	0.0						
58.	35	1.012	0.3667	0.9996	1.0014	1.0059	0.0	0.0	0.0	0.0	0.0	0.0	0.0						
68.	36	1.012	0.3677	1.0001	1.0022	1.0020	0.0	0.0	0.0	0.0	0.0	0.0	0.0						

**DISTRIBUTION LIST FOR COMPRESSOR
MODELING REPORT (CONTRACT NAS3-18535)**

PRATT & WHITNEY

Pratt & Whitney Aircraft
400 Main Street
East Hartford, CT 06108

Attn:

Mr. George Dolde
Mr. Robert Mazzawy
Mr. Walter Stubner
Mr. Ron King, Eng. 2F
Mr. Joe Tringali, MSEB2B
UTRC Library
Mr. A. Mikolajczak
Mr. Dave Motycka
Mr. George Banks

Pratt & Whitney Aircraft
Florida Research & Development Center
Attn: Mr. S. H. Ellis
P. O. Box 2691
West Palm Beach, FL 33402

Pratt & Whitney Aircraft
Division of United Aircraft
Attn: Mr. Joseph Chew
20800 Center Ridge Road
Rocky River, OH 44116

United Aircraft Research Labs.
Attn: Mr. Franklin O. Carta
Aeroelastics Branch
400 Main Street
East Hartford, CT 06108

Administrative Contracting Officer
Naval Plant Representative Office
Pratt & Whitney Aircraft
East Hartford, Connecticut 06108

GENERAL ELECTRIC

General Electric Company
Aircraft Engine Group
Cincinnati, OH 45215

Attn:

Mr. Vernon Reed E198
Dr. Roy Smith H43
Mr. Paul H. Kutchenreuter, Jr. K69
Mr. J. Klapproth K96
Mr. T. Collins E198
Dr. W. Steenken E198
Technical Information Center N32

General Electric Company
Attn: Mr. Mike Toth
5300 Riverside Drive
Cleveland, OH 44135

General Electric Company
Attn: Mr. Les King 240 G9
Mr. Tom Foy 240 G4
Technical Information Center
1000 Western Avenue
Lynn, MA 01910

General Electric Company
Attn: Dr. H. K. Lin
Corporate Research & Development
Box 43
Schenectady, NY 12301

NASA

National Aeronautics & Space Administration
Attn: RL/H. Johnson
Washington, DC 20546

Langley Research Center
Attn: Mr. W. P. Henderson
Propulsion Aero. Branch, MS: 189
Hampton, VA 23665

Ames Research Center
Attn: Mr. Daniel Benze
MS: 227-8
Moffett Field, CA 94035

Flight Research Center
Attn: Mr. William Schweikhard
P. O. Box 273
Edwards, CA 93523

Lewis Research Center
21000 Brookpark Road
Cleveland, OH 44135

Attn:		copies
Mr. Ross Willoh	MS: 60-6	(1)
Mr. Bill Braithwaite	MS: 60-6	(3)
Mr. Ed Graber	MS: 60-6	(3)
Mr. Dave Evans	MS: 60-4	(3)
Dr. Tony Kurkov	MS: 60-4	(3)
Mr. Dave Bowditch	MS: 86-1	(2)
Mr. Dan Drain	MS: 100-1	(2)
Mr. Mel Hartmann	MS: 5-9	(2)
Mr. N. Musial	MS: 500-113	(1)
Mr. Leonard Schopen	MS: 500-206	(1)
Dr. John Adamczyk	MS: 5-9	(1)
Report Control Office	MS: 5-5	(1)
Library	MS: 60-3	(2)
Mr. Lawrence Ludwig	MS: 23-2	(1)
Mr. Warner Stewart	MS: 3-5	(1)
Mr. Roy Hager	MS: 5-9	(1)

NASA Scientific & Technical Information Facility
Attn: Acquisition Branch
P. O. Box 33
College Park, MD 20740

(10 + all remaining copies, and 6 copies of the Document
Release Authorization Form FF427)

MILITARY

Wright-Patterson Air Force Base
Wright-Patterson AFB, OH 45433

Attn:

AFAPL/TBC Mr. Marvin Schmidt
AFAPL/TBC Mr. Marvin Stibich
AFAPL/TBA Mr. Ivan Bush (4 copies)
AFAPL/CCN Dr. Hans J. P. Von Ohain
AFAPL/TBC Dr. Francis Ostdiek
AFAPL/TBD Mr. Len Obery LeRC
AFFDL/FXM Mr. Dennis Sedlock
AFFDL/FXM Mr. Keith Richey
AFENF Major D. H. Quick

ARO, Inc.
Arnold Air Force Station, TN 37389
Attn:
Mr. Bill Kimsey (2 copies)
AEDC/ARO/ETF
Mr. John Martin &
Mr. Larry Galiger
AEDC/ARO/PWT

Arnold Air Force Station ~
Attn: Dr. Heiser, Chief Scientist
Arnold Air Force Station, TN 37389

ARO, Inc.
Engine Test Facility
Attn: Mr. Jack Tate
Arnold Air Force Station, TN 37389

ARO, Inc.
Arnold Engineering Development Center
Attn: Mr. J. L. Jackocks
Arnold Air Force Station, TN 37389

Naval Postgraduate School
Department of Aeronautics
Attn: Professor Paul Pucci
Monterey, CA 93940

Naval Air Propulsion Test Center
Trenton, NJ 08628
Attn:
Mr. J. F. Boytos PE-52
Mr. Donald Brunda
Mr. Vernon Labosky

Naval Air Systems Command
Attn: Mr. Dan Alexander
AIR53631E
Washington, DC 20360

Naval Air Development Center
Attn: Mr. Thomas J. Brennan
Head, Propulsion Branch
Warminster, PA 18966

INDUSTRY

Northrop Corporation
Aircraft Division
Attn: Mr. R. D. Sutton
3901 West Broadway
Hawthorne, CA 90250

Lockheed-California Co.
Attn: Mr. T. A. Sedgwick
Dept. 74-14, Bldg. 63G
Plant A-1
P. O. Box 551
Burbank, CA 91053

LTV Aerospace Corporation
Attn: Mr. William E. Simpkin
Vought Systems Division
P. O. Box 5907
Dallas, TX 75222

Attn:
Mr. H. C. Melick, Jr.
Aerodynamics Specialist

Grumman Aerospace Corporation
Attn: Mr. Clifford A. Hoelzer
Head, Airbreathing Propulsion
Plant 5
Bethpage, NJ 11714

AVCO Lycoming Division
Attn: Library
550 S. Main Street
Stratford, CT 06497

INDUSTRY

Rolls-Royce (1971) Ltd.
Bristol Engine Division
Attn: Mr. Darrell Williams
Installed Aerodynamics Dept.
Box 3, BS127QE
Filton, Bristol, England

Teledyne
Attn: Library
1330 Laskay Road
Toledo, OH 43967

AiResearch Manufacturing Company
of Arizona
402 South 36th Street
Phoenix, AZ 85034

Attn:
Dr. William F. Waterman
Supervisor, Aerodynamics
Dept. 93-350M

Mr. G. A. Burnett
Department 93-353M

Library

Advanced Technology Laboratories, Inc.
Attn: Dr. John Erdos
Merrick & Stewart Avenues
Westbury, NY 11590

The Boeing Company
Attn: Mr. G. Lampard
Mail Stop 8C-27
P. O. Box 3999
Seattle, WA 98124

McDonnell-Douglas Corporation
Attn: Mr. A. P. Farr, III
Bldg. 33, Level 15 North
P. O. Box 516
St. Louis, MO 63166

Attn:
Mr. Hershel Sams
Br. Mgr. Propulsion

Douglas Aircraft
Attn: Mr. Ron Kwai
Mail Code 36-41
3855 Lakewood Blvd.
Long Beach, CA 90846

General Dynamics Corporation
Attn: Mr. P. P. Truax
Convair Aerospace Division
P. O. Box 748, M/Z 2892
Fort Worth, TX 76101

Attn:
Mr. Robert A. Stevens
Mr. L. H. Schreiber

Rockwell International
International Airport
Los Angeles, CA 90009

Attn:
Mr. C. J. MacMiller
B-1 Division, Mail Code AB 70

Mr. Robert H. Johnson
Mail Code AB 71

Rockwell International
Columbus Aircraft Division
Attn: Library
4300 East 5th Avenue
Columbus, OH 43216

Garrett AiResearch Manufacturing Co.
Attn: Library
2525 West 190 Street
Torrance, CA 90509

General Motors Corporation
Detroit-Diesel, Allison Division
P. O. Box 894
Indianapolis, IN 46206

Attn:
Mr. Samy Baghdati

Library

Mr. J. A. Korn
Mail Stop U28

SCHOOLS

Massachusetts Institute of Technology
Gas Turbine Laboratory
Attn: Mr. Jack L. Kerrebrock
Cambridge, MA 02139

Virginia Polytechnic Inst. & State University
Attn: Mr. W. F. O'Brien, Jr.
Mechanical Eng. Department
Blacksburg, VA 24061

Penn State
Attn: Dr. Robert Henderson
Associate Prof. of Engr. Research
Ordinance Research Laboratory
P. O. Box 30
State College, PA 16801

The Ohio State University
Attn: Prof. John D. Lee
Dept. of Aeronautical & Astronautical Engr.
Neil Avenue
Columbus, OH 43210

Iowa State University
Attn: Dr. George Serovy
Department of Mechanical Engineering
Ames, IA 50010

Purdue University
Attn: Prof. Mel R. L'Ecuyer
School of Mechanical Engineering
Jet Propulsion Center
Lafayette, IN 47097

Attn:
Prof. S. N. B. Murthy

Pennsylvania State University
Department of Aerospace Engineering
Attn: Dr. N. Litaram
233 Hammond Bldg.
University Park, PA 16802

Daniel and Florence Guggenheim
Jet Propulsion Center
California Institute of Technology
Attn: Prof. W. D. Rannie
Pasadena, CA 91109