

General Disclaimer

One or more of the Following Statements may affect this Document

- This document has been reproduced from the best copy furnished by the organizational source. It is being released in the interest of making available as much information as possible.
- This document may contain data, which exceeds the sheet parameters. It was furnished in this condition by the organizational source and is the best copy available.
- This document may contain tone-on-tone or color graphs, charts and/or pictures, which have been reproduced in black and white.
- This document is paginated as submitted by the original source.
- Portions of this document are not fully legible due to the historical nature of some of the material. However, it is the best reproduction available from the original submission.

A MICROPROCESSOR CONTROLLED PRESSURE SCANNING SYSTEM

Robert C. Anderson
Lewis Research Center
Cleveland, Ohio 44135

E-8665

ABSTRACT

A microprocessor-based controller and data logger for pressure scanning systems is described. The microcomputer positions and manages data from as many as four 48-port electro-mechanical pressure scanners. The maximum scanning rate is 80 pressure measurements per second (20 ports per second on each of four scanners). The system features on-line calibration, position-directed data storage, and once-per-scan display in engineering units of data from a selected port. The system is designed to be interfaced to a facility computer through a shared memory. System hardware and software are described. Factors affecting measurement error in this type of system are also discussed.

INTRODUCTION

Microprocessors can impact the computerization trend in large aerospace test facility measurement systems by making "smart" instruments feasible. These instruments generally simplify the main computer-instrument interface and can also relieve the main computer from the timing and bookkeeping of instrument managing. This paper describes the coupling of a microcomputer and several pressure scanners to create a "smart" pressure scanning system. Pertinent features of this scanning system are self-calibration, position-directed data storage (i.e. the scanner position determines where the data is stored), checkout capability, and fault detection. The system was designed to eliminate the external-system dependence and the large amount of required pre-run adjustment common with pressure scanning systems previously used at Lewis Research Center.

The pressure scanning system has been built and is operating in a full scale engine test facility and another is planned for a new engine component research facility. Moreover, a primitive hard-wired version of the system (without the microcomputer) has been operating for over one year. This report describes the microcomputer-based system design philosophy and the design of the system hardware and software. In addition, tests and operational experience on both the microcomputer and the hard-wired systems are also discussed.

SYSTEM DESIGN PHILOSOPHY

This section introduces the system and briefly dis-

cusses the general design goals. The word "system" here refers to a multicomponent device whose input is pressure and whose output is binary numbers proportional to the pressures.

The system design was motivated by the need for a system that could consistently produce valid, accurate data without any manual pre-run adjustments and for a system whose operation would not be dependent on other facility systems. In addition, checkout assistance and fault detection were considered highly desirable features. Cost, primarily manpower cost, was also a factor in the design. As a result, commercially available equipment was used wherever possible. Both the pressure scanner and the modular microcomputer system are commercially available. Also a high-level programming language was used to write the microcomputer programs to cut down programming time.

Hands off operation of the system is achieved primarily by making the system self-calibrating. The whole data acquisition process is controlled by the microcomputers, which makes the system completely independent of external facility systems.

Figure 1 is a block diagram of a complete system. The scanning system includes the microcomputers, scanners, reference pressure generators, and a shared data memory module connected to all the microcomputers. In normal operation the microcomputers step the scanners and acquire data after each step. The system can measure as many as 768 pressures at rates as high as one update for every measured pressure every 2.5 seconds.

The data are stored in the shared data memory according to the scanners' positions. The reference pressures are connected to the scanners and measured with the other pressures so that the system calibration can be determined. The master facility computer shares the data memory and may interrupt the system at any time to read the data. Some data display and fault checking are provided by the microcomputers when the system is running.

Checkout assistance is provided by front panel displays and manual controls. Displays include sequence fault lights for each scanner and continuous once-per-scan display of a selectable data word either as raw counts or converted to engineering units. Front panel control includes scanning rate

selection, selection of data word for display and the selection of the type of display (counts or psi). Another front panel control stops the scanners when a selected scanner is on a selected port and updates the display with the data from that port. This feature is valuable for initial setup where the system gain is matched to a newly installed transducer. This stop mode is also useful for leak detecting and system noise determination.

SYSTEM DESIGN

Pressure Scanner

A block diagram of one pressure scanner is shown in Fig. 2. The scanner contains a pressure selector switch with its transducer, the switch drive motor, an optical position encoder and the scanner electronics module. A photograph of the scanner is shown in Fig. 3. The pressure selector switch is a rotary type with a centrally mounted transducer. Surrounding the transducer is a bulkhead having 48 ports. Pressures applied at these ports are selected and transmitted to the transducer through a channel in a movable rotor. Figure 4 shows a diagram of this operation. The scanner electronics module provides the drive signals to the motor and implements a STEP command and a HOME command when they are received from an external source. The electronics module also reads the binary encoded position and transmits the reading to the scanner output.

Reference Pressure Generator

The reference pressure generator used in these systems is a deadweight type regulator. The expected error of the generator is ± 0.025 psi or .025 percent of the set point, whichever is greater.

Microcomputer

Components. - The modular microcomputer system used for the scanner controller is based on an 8-bit integrated circuit microprocessor. This processor can address 16 384 8-bit bytes of memory and can access 32 input/output ports (8 inputs and 24 outputs). The card system shown in Fig. 5 interfaces to the processor and provides (1) a 14-bit address and data-out buss (2) an 8-bit data-in buss (3) an 8-bit memory data-in buss and (4) an 8-bit memory data-out buss. A block diagram of the card system is shown in Fig. 6. In addition to the computer system modules, several modules were designed for scanner transducer signal processing. These included a pre-amplifier card, a 4-channel analog multiplexer card, and an A/D (Analog-to-Digital) converter card. In the text that follows the system of cards described above and their interconnections will be called the microcomputer system.

It is not the purpose here to detail the circuits used in the system. However, there are some items having to do with the transducer data path that are important. The transducer data path is shown in Fig. 7. The analog transducer output is amplified with a gain of at least 100 before it reaches the A/D converter which has an input range of ± 5 volts DC. The only adjustment needed in this system is required when a new transducer is first installed.

To maximize the resolution, the pre-amplifier gain is adjusted so that the A/D converter puts out approximately full scale when the transducer sees the maximum pressure to be measured. The A/D converter output is a 12-bit binary number, offset so that zero out means $-5V_{DC}$ input and 4096 out means $+5V_{DC}$ input. The adjustment need only be approximate because of the self-calibration capability of the system. In general, the transducer will use only half the range of the A/D converter unless it is a differential unit which can make the plus to minus full scale excursion. When the transducer uses half scale of the A/D converter (2000 counts) the resolution is then 0.05 percent of full scale (1 binary bit out of 2000). This is sufficient because it is equal to or less than the expected random errors in the system. The systematic errors, as will be discussed later, are eliminated by calibration.

The digital portion of the transducer data path is also shown in Fig. 7. It is important to note that the A/D converter output is 12-bits. Because the microcomputer works with 8-bits at a time the data is divided into two 8-bit bytes. These bytes, one with 8-bits of data and the other with 4 bits, are stored in memory one at a time. It is therefore necessary to prevent the master computer from reading the data between the storing of the two data bytes.

Front panel controls and displays. - The microcomputer front panel is shown in Fig. 8. The elements include four SEQUENCE FAULT lights (one for each scanner), a four digit decimal display, three push buttons lighted to show their function, and thumb-wheel switches. Pushing the SET RATE button starts the system, which selects the scanning rate from the RATE-PORT thumbwheels. After start, the VALVE and RATE-PORT thumbwheels control the display along with the PSI/COUNTS button. The operating mode is controlled by the STOP/RUN button. The functions of all the front panel elements will be detailed in a later section.

Microcomputer-master computer interface. - The hardware described above can acquire and store data from as many as four pressure scanners. The memory share controller connects to four microcomputers and allows all the microcomputers and the facility master computer to access the data memory. The address buss and the data buss to the memory are switched to let the microcomputers read and write, while the master computer may read only.

Under certain conditions the master computer may be locked out of the data memory. The master computer is locked out (1) if the microcomputer has executed a HALT instruction (2) if the microcomputer is presently using the memory and (3) if the microcomputer is between bytes, storing a data work. In cases 2 and 3 the master will wait at most 2.5 milliseconds before getting control. In case 1 operator action is required.

PROGRAM

Overview. - The largest portion of the software for the scanner controller was written using a high level language written for the microprocessor called

ORIGINAL PAGE IS
OF POOR QUALITY

PL/M. The program is given in appendix A. Assembly language was used for several things that PL/M did not do efficiently and a commercially available software floating-point package was used for engineering unit calculations. Before getting into details of the software, it is helpful to briefly discuss the memory usage in the microcomputer.

Memory allocation. - The addressable memory of the microcomputer is conveniently divided into 64 pages of 256 bytes each. This means that the most significant 6 bits of memory address indicates the page while the least significant 8 bits indicates the location on the page. The memory allocation for the controller system is shown in Fig. 9. The program is located in 5 pages of non-volatile PROM (Programmable Read-Only Memory), and the so-called scratch pad memory is in page 8 of RAM (Random Access Memory).

The data memory starts at page 16 of RAM where data from each scanner are stored in a separate page. The scanning rate is stored in location zero of each data page and the high and low reference pressure values are stored in location 100-103 of page 16.

Controller program. - The controller program flow chart is given in Fig. 10. The program can be divided into six functions.

1. Initialization.
2. Scanner data acquisition and storage.
3. Data display.
4. Engineering unit calculation.
5. Operating mode control.
6. Sequence fault check.

Initialization - Upon power up or when the SET RATE button is pushed, the computer reads a binary rate value from the dual purpose RATE-PORT thumbwheels on the front panel. The binary number is read as ports-per-second with an allowable range of 1 to 20. If an illegal rate (greater than 20) is read, the computer begins to flash "9999" on the decimal display until the thumbwheel switches are set to a legal rate. In addition, the illegal rate causes the rate bytes in the data memory to be cleared so that the master computer knows that the scanners are not scanning. As soon as a legal rate is read, the computer gets a double byte delay number from a rate-dependent location in a table. The delay number is stored in a software timer control word. The software timer is used to time out the period between scanner step commands. The program then sends a home command to the scanners and enters a data acquisition loop.

Scanner data acquisition and storage - Within the data acquisition loop, executed every step, are the step command, fault detection, display control, and a smaller loop which acquires a reading from each of the four scanners after every step. Acquiring a reading means; (1) reading the position from the scanner of interest, (2) switching the analog multiplexer to the signal from the transducer of interest, (3) commanding the A/D converter to digitize the transducer signal and (4) storing the 12 bits of digitized data in the two 8 bit memory words assigned to the port number read in step 1.

To acquire data from one port on each of the four scanners requires 5 milliseconds.

For optimum data reliability it is necessary to let the scanners sit on a port as long as possible before reading to minimize the effects from initial pneumatic switching transients. So ideally the transducer should be read at the moment just before the switch to the next port. In the scanners used there is a 10 to 20 millisecond delay between the step command and the actual step. This delay means that after the command to step to a port there is still some settling time available on the previous port. This system uses the extra settling time by sending the step command before it reads the transducers.

Data display - Before the step-acquire-data sequence starts each time, the computer reads the VALVE thumbwheel switch on the front panel. Then the computer compares the position reading from the selected scanner to the PORT thumbwheel switch setting. If a match occurs the display flag is set. Otherwise the flag is reset. The display flag causes the "DISPLAY" subroutine to be called when data acquisition is complete. This routine has two modes; (1) display counts (0 for negative full scale to 4096 for positive full scale) or (2) display engineering units. The mode is determined by sensing the position of the "PSI/COUNT" switch on the front panel.

Display is accomplished by converting the binary number to be displayed to 4-digit BCD (Binary Coded Decimal). The microcomputer sends the BCD code to the four decimal digit display on the front panel.

Engineering unit calculation - When the PSI display mode is called for, the computer uses preset values for high and low calibration pressures to calculate the result of the following equation:

$$P_x = P_L + \left[\frac{P_H - P_L}{C_H - C_L} \right] [C_X - C_L]$$

where

- P_x is the unknown pressure.
- P_L is the low calibration pressure.
- P_H is the high calibration pressure.
- C_H is the counts read on the high-cal port.
- C_L is the counts read on the low-cal port.
- C_x is the counts read for the port of interest.

The floating point software is used only for the multiplication and division. The same display routine described above is used to display the result.

Several important facts should be pointed out here. First the microcomputers do not do this calculation for every port but only for one port per scan and then only if the PSI/COUNTS switch is in the PSI position. The data memory never has the results of this computation. So that the master computer must do this same calculation for each pressure of interest to get psi. Lastly, the engineering unit calculation in either computer assumes linearity over the calibration range. This means that both non-linearity and hysteresis will contribute to error in the result.

ORIGINAL PAGE IS
OF POOR QUALITY

Operating mode control - The STOP/RUN switch position determines the operating mode. The RUN mode is described above. If the STOP position is sensed, the computer deletes the step commands when the display flag is set. This effectively stops the scanners when the selected scanner is on the selected port of interest. The data display continues to be updated at the last rate selected.

Sequence fault check - At the beginning of the data acquisition loop each scanner's position is stored in a memory location. The positions after the step are compared to the stored positions. If the after-step position of a scanner is not exactly one more than the before-step position, the SEQUENCE FAULT light for that scanner is lit. The fault indicators are updated after every step. The sequence fault indicators will light once per scan when the positions go from port 48 to port 1. This can be used as a front panel indication that the scanners are scanning.

Master computer program. - Something should be said about how the master computer reads data from the shared memory. The master computer must send an address to the memory controller for every byte of data it wants to read. The memory controller switches the data memory to the master computer if none of the previously mentioned lock-out conditions exist. There are two ways provided for the master computer to know that it has data memory control. First, a "ready" signal is received and second, address "1" in any data memory page will contain a zero if control has been switched to the master computer. The master computer must send two sequential addresses for each scanner data word because of the one-address one-byte rule. If the memory controller has to wait longer than 10 milliseconds from one master computer address to another, data memory control is automatically switched back to the micro-computers.

OPERATIONAL EXPERIENCE AND TESTS

To date both a microcomputer system and a more primitive hard-wired system without a microcomputer have been installed, tested, and are operating. In fact, the hard-wired system has been operating for over one year, producing accurate data without any manual adjustments except for the original setup. The systems are tested for accuracy by applying precisely known pressures to the scanner and comparing measured values to known values. These tests, both in the lab and on installed systems have shown the system error to be typically less than ± 1.5 percent of the calibration range.

It is important to know some of the factors which contribute to system measurement error in order to understand the significance of the tests. Only random errors need to be considered because the self-calibration feature eliminates systematic errors. This calibration not only eliminates error due to transducer zero shifts and sensitivity changes but also error from drifts in amplifier gain and zero offset.

First, consider the random error in the transducer signal path. Nonlinearity and hysteresis in all the components plus A/D converter resolution error will

affect the system error. The largest of these is the A/D converter resolution error which is adjusted to be about ± 0.5 percent of the calibration range. The other errors are less than 0.01 percent of the calibration range. The transducer producing the signal will have typical nonlinearity of 0.15 percent transducer full scale and typical hysteresis of 0.05 percent full scale. Adding to these errors is the uncertainty in the reference pressures which is ± 0.025 percent of the pressure. These random error values lead to a root-sum-square error estimate of less than ± 1.5 percent of the calibration span.

Pneumatic effects in the pressure selector switch and associated tubing can also cause errors. Referring to Fig. 4, the so called switched volume at pressure P_{n-1} , causes transient pressure effects as it equalizes to pressure P_n . Thus the pressure in the volume may overshoot P_n and oscillate. Or the pressure may asymptotically approach the true value when the pressure is low or the tubing is small and viscous effects are dominant. If the system is allowed to settle long enough for these transients to pass before data are taken, the data will be valid.

The scanning rate, the size of the switched volume, the pressure levels and their scanning order affect the severity of these transients. Specifically, the switched volume should be minimized (< 40 cubic mm) and the scanning order should be arranged to minimize the number of large changes in pressure level between adjacent ports. A selected scanning rate may be evaluated by comparing data at that rate with data taken at the lowest rate (1 port/sec). If they are essentially the same, the selected rate is acceptable. When transient errors are minimized as above, rates as high as 15 ports per second can yield errors as low as ± 1.5 percent of the calibration ranges. This result was determined from a series of calibration tests. Applied test pressures were varied from 1 psia to 500 psia with port-to-port pressure changes that ranged from 0 percent to 100 percent of the calibration range. Typical results when the rate was optimized showed greater than 90 percent of the readings (a typical group numbered 400) fell within ± 1.5 percent of the true value.

SUMMARY AND CONCLUDING REMARKS

The microcomputer controlled pressure scanning system shown in Fig. 1 is capable of measuring pressures at rates as high as 768 pressures every 2-1/2 seconds assuming a 20 port second rate. The scanning system is a solution to the problem of economically measuring hundreds of steady-state pressures in large test facilities. The system has such features as calibration capability, position-directed data storage, sequence fault indication, and continuous display of a data word once per scan in counts or in engineering units. The output of the scanning system can be easily interfaced to a computer. The microcomputers store the scanner data in a data memory which can be read at any time by the facility master computer. Tests have shown the system to be highly reliable. One system has been operating over one year and yielding accurate data without requiring any adjustments. Tests for accuracy over the operational period of these systems have shown the

4

ORIGINAL PAGE IS
OF POOR QUALITY

the system is capable of measurements with errors less than ±0.15 percent of the calibration range.

APPENDIX A.
MULTIPLE PRESSURE SCANNER CONTROL PROGRAM

```
ALL PROGRAM VARIABLES ARE DEFINED BELOW
ACTUAL PROGRAM BEGINS AT LABEL 'CALLRATE'
*****
JDR:  DECLARE (STATUS,BCD,SCRATCH,BITHI,BTMP) BYTE;
      DECLARE (MATCH,DVALUE) BYTE;
      DECLARE (POS,POSTMP) (5) BYTE;
      DECLARE (QB,XRATE) ADDRESS,
            (A) (2) BYTE,
            (VALVENUM,INDEX,POSHEAD) BYTE,
            (C BASED QB) BYTE,
            (TMPUT,SAVQB) ADDRESS,
            (DELSC,DELSCX,D BASED QB) ADDRESS,
            (STATUSSTORE) BYTE,
            (ENG1,ENG2) ADDRESS,
            (OZOH1,OZLO,O19H1,O19LO) BYTE;
      DECLARE QA ADDRESS,ASCATCH BASED QA ADDRESS,
            BSCATCH BASED QB ADDRESS;
      DECLARE XRATEDX ADDRESS;
      DECLARE BSET2 DATA
*****
FIRST LOCATION IS BASE ADDRESS
*****
(4000H,4PC2H,27E2H,19EDH,1372H,0F2RH,
 0C27H,0AD5H,C9BAH,08A5H,0795H,
 069RH,057DH,0C73H,046CH,0464H,
 045EH,035BH,035BH,034FH,034BH,
 0FF7H,0FF7H,0FF7H);
      DECLARE BSET BASED BSET ADDRESS;
      DECLARE CHECKS LITERALLY '070H';
      DECLARE ZERORATES LITERALLY '0A9H',
            CONVSHANDLS LITERALLY '0C0H',
            SAVESPOS LITERALLY '11FH',
            RATESZRO LITERALLY '134H',
            STOPSHARES LITERALLY '139H',
            SHORTSTORES LITERALLY '143H';

14DH:CHECK:  PROCEDURE;
             GO TO CHECKS;
             END CHECK;
ZERORATE:   PROCEDURE;
             GO TO ZERORATES;
             END ZERORATE;
CONVSHANDL: PROCEDURE;
             GO TO CONVSHANDLS;
             END CONVSHANDL;
SAVESPOS:  PROCEDURE;
             GO TO SAVESPOS;
             END SAVESPOS;
RATESZERO: PROCEDURE;
             GO TO RATESZEROS;
             END RATESZERO;
STOPSHARE: PROCEDURE;
             GO TO STOPSHARES;
             END STOPSHARE;
SHORTSTORE: PROCEDURE;
             GO TO SHORTSTORES;
             END SHORTSTORE;
*****
PROCEDURE TO TIME OUT A GIVEN NUMBER OF MILLISECONDS
A(I) HAS NUMBER OF 12.5 MILLISECOND PERIODS
A(O) HAS NUMBER OF 3.625 MILLISECOND PERIODS
*****
TIMER:      PROCEDURE;
             BTMP=A(I);
TSTHI:      IF BTMP=0 THEN GO TO TSTLO;
             BTMP=BTMP-1;
             CALL TIME(200); /****** 12.5 MSEC */
             GO TO TSTHI;
TSTLO:      IF A(O)=0 THEN RETURN;
             CALL TIME(A(O)); /****** .625 MSEC */
             RETURN;
             END TIMER;
*****
PROCEDURE TO CONVERT A 2-DIGIT BCD TO BINARY
INPUT IS A VARIABLE KNOWN TO ALL AS "BCD"
*****
BCD2OSBIN:  PROCEDURE BYTE;
             RETURN (BCD AND 0FH)
             *(SHR((BCD AND 0F0),1))
             *(SHR((BCD AND 00H),3));
             END BCD2OSBIN;
*****
PROCEDURE THAT FLASHES "9999" ON THE CONTROLLER FRONT PANEL
*****
FLASH9:    PROCEDURE;
*****
'ZERORATE' CALLS A SECTION OF THE "CHECK" ROUTINE
TO ZERO THE ANCILLARY INFORMATION
IF THE OPERATOR HAS ENTERED AN ILLEGAL RATE
*****
CALL RATESZRO; /*SETUP FOR ZEROING THE RATES */
CALL ZERORATE; /* DO IT */
OUTPUT(6)=99H;
OUTPUT(7)=99H;
A(I)=13H;
CALL TIMEN;
OUTPUT(6)=0FFH;
OUTPUT(7)=0FFH;
CALL TIMEN;
RETURN;
END FLASH9
```

```
*****
PROCEDURE TO SET THE RATE AND SET UP THE TIMER CONTROL WORDS
INPUT IS A THUMBWHEEL SWITCH SETTING CONNECTED TO THE 5TH
PORT OF THE EXTENDED INPUT CHANNEL 7
*****
TIMERSET:  PROCEDURE;
SETBAGN:   OUTPUT(1)=5;
           BCD=INPUT(7);
           IF (LOW(XRATE)=DOUBLE(BCD2OSBIN)<21D)
               THEN GO TO NOERR;
*****
FLASH "9999" ON THE DISPLAY IF THE RATE IS ILLEGAL
*****
ERR:       CALL FLASH9;
           GO TO SETBAGN;
*****
PICK OFF THE 1+1TH DOUBLE BYTE WORD IN BSET2 FOR THE RATE
WHERE THE I IS XRATE AND THE VARIABLE HAS THE BASE AT IT'S
FIRST DOUBLE BYTE WORD.
*****
NOERR:     XRATEDX=BSET(LOW(XRATE));
*****
SET THE COARSE AND THE FINE TURNS ACCORDING TO BSET2 NUMBERS
*****
A(I)=LOW(XRATEDEX);
A(O)=HIGH(XRATEDEX);
RETURN;
*****
END TIMERSET;
*****
PROCEDURE TO CALCULATE ENGINEERING UNITS
*****
ENGR:      PROCEDURE ;
           OR=SAVQB;
SETDELSC:  DELSC=D(I)-D(I);
           IF DELSC=0 THEN RETURN 0;
           DELSC=TMPUT - D(I);
*****
CALL ROUTINE TO HANDLE THE ENTRY INTO THE FLOATING POINT CALCULATIONS
*****
STARTSCONV: CALL CONVSHANDL;
ENDENG:     END ENGR;
*****
PROCEDURE TO DISPLAY A FOUR-DIGIT BCD NUMBER ACCORDING TO
THE BINARY WORD IN "TMPUT"
*****
DISPLAY:   PROCEDURE;
*****
STORE 10*PSI IN TMPUT SO THE 4-DIGIT DISPLAY
WILL SHOW XXX.X PSI
*****
IF (INPUT(5) AND 4H)=4 THEN GO TO PLAINOUT;
CALL ENGR;
*****
OUTPUT OF TMPUT AS XXX.X PSI OR XXXX COUNTS
*****
PLAINOUT:  OZOH1=0;
           OZLO=0;
           O19H1=0;
           O19LO=0;
TST1000:   IF TMPUT < 1000 THEN GO TO TST100;
           OZOH1=OZOH1+1;
           TMPUT=TMPUT-1000;
           GO TO TST100;
TST100:    IF TMPUT < 100 THEN GO TO TST10;
           OZLO=OZLO+1;
           TMPUT=TMPUT-100;
           GO TO TST10;
TST10:     IF TMPUT < 10 THEN GO TO ADOUT;
           O19H1=O19H1+1;
           TMPUT=TMPUT-10;
           GO TO TST10;
ADOUT:     O19LO=LOW(TMPUT);
           OUTPUT(7)=SHL(OZOH1,4)+OZLO;
           OUTPUT(6)=SHL(O19H1,4)+O19LO;
           RETURN;
           END DISPLAY;
*****
PROCEDURE TO READ THE SCANNERS AND STORE DATA
*****
VALVESREAD: PROCEDURE;
           MATCH=1;
           TSTIFDELSCPL: OUTPUT(1)=6;
           IF (XWATCH=BCD2OSBIN) THEN MATCH=0;
           READ SCANNER NUMBER FROM THE THUMBWHEEL SWITCH CONNECTED TO INPUT '07-6'
           BCD=SHR(INPUT(7),4);
           TSTSPORT:  OUTPUT(1)=DVALUE=BCD2OSBIN; /* THB VALVE */
           SET A REG TO SCANNER NUMBER IN ORDER TO READ EXTENDED INPUT 07-(VALVENUM)
           SCRATCH=INPUT(7); /*READ POSITION */
           IF (SCRATCH=10H) THEN SCRATCH=0H;
           CONVERT 48 TO 0 BECAUSE FRONT PNEUMATIC PANEL CONNECTOR SAYS PORT "0"
           WHILE THE OPTICAL ENCODER PUTS OUT A "48"
           OUTPUT(1)=5;
           BCD=INPUT(7); /* READ THB POSITION */
           IF (XWATCH=BCD2OSBIN) THEN MATCH=0;
           TSTIFSTOP: IF (INPUT(5) AND 4H) OR MATCH=0
                   THEN GO TO NOSTEP;
           MATCH = 0 MEANS WE'RE ON IT
           INPUT 48 = 0 MEANS WE WANT A STOP, SO.....
           IF WE'RE ON IT AND WE NEED A STOP,....THEN DON'T STOP
           ACCESS LOC 17D PG 16 TO LOCK OUT MEM SHRE.
           CALL STOPSHARE;
           STEPVALVES: OUTPUT(4)=0FB;
                   OUTPUT(4)=0;
                   CALL TIME(16);
                   CALL TIME(16);
           NOSTEP:  QM=0F0H;
                   VALVENUM=1;
           SETSTOPENAS: QB=QB+10FH;
```

E-8665

ORIGINAL PAGE IS
OF POOR QUALITY

```

/*****
SET THE BASE ADDRESS FOR STORING THE DATA
AND
SET ANCILLARY FIRST WORD EQUAL TO THE RATE
*****/
IF (INPUT (5) AND 0H) = 0H THEN BSCRATCH=KRATE;
/*****
INPUT 05 = 0H MEANS THAT WE'RE NOT STOPPED
SO SET THE ANCILLARY RATE
*****/
OUTPUT (1)=VALVNUM;
INDEX=SHL (POSREAD);=(INPUT (7) AND 3FH); 1;
FOR (VALVNUM)=POSREAD;
ASDCONVRT: OUTPUT (3)=0H;
/*START THE ANALOG TO DIGITAL CONVERTER */
OUTPUT (3)=00H;
STOREDATA: C (INDEX)=INPUT (3); /******LSB*/
/*****
CALL THE SHORT ROUTINE TO STORE THE NEXT BYTE
*****/
CALL SHORTSTORE;
IF (MATCH=1) THEN GO TO CHGSMUX;
IF (VALVNUM<>DVALUE) THEN GO TO CHGSMUX;
SAVE=00;
/*****
SET INPUT EQUAL TO THE DATA WORD JUST READ
ON THE REQUESTED SCANNER
IF THE PORT MATCHES THE REQUESTED ONE.
*****/
INPUT=D (POSREAD);
CHGSMUX: IF (VALVNUM:=VALVNUM+1)=5 THEN GO TO VREADSOUT;
OUTPUT (2)=VALVNUM-1;
GO TO SETSTORIEAS;
VREADSOUT: IF (MATCH=0) THEN CALL DISPLAY;
RETURN;
END VALVREAD;

/*****
SET SCAN RATE AND HOME THE VALVES
*****/
CALLSRATE: CALL TIMERSSET;
HOMESVALVES: OUTPUT (5)=00FH;
A (1)=7FH;
CALL TIMER;

/*****
RESET COARSE TIMER INDEX FOR CORRECT PERIOD BETWEEN STEPS
*****/
A (1)=LOW (CRATEDEX);
/*****
THEN ENTER ANCILLARY INFO 'LOW REF' AND 'HIGH REF'
SET THE BASE
*****/
QA=1060H;
ASCPATCH (1)=DOUBLE (0H);
ASCRATCH (2)=DOUBLE (10D);
MURERESET: OUTPUT (2)=0H;
PRESSAVEPOS: POSTMP (1)=POS (1);
/*****
CALL ASSEMBLY LANGUAGE ROUTINE FOR SAVING THE LATEST POSITIONS
*****/
SAVE: CALL SAVEPOS;
/***** READ VALVES AND POSITIONS */
READ: CALL VALVREAD;
/*****
CALL ASSEMBLY LANGUAGE ROUTINE FOR SEQUENCE CHECK AND FAULT LIGHT CONTROL
*****/
CHECKVALVE: CALL CHECK;
/*****
CALL THE TIMER SUBROUTINE WHICH
DELAYS UNTIL THE CORRECT PERIOD BETWEEN STEPS
HAS ELAPSED - - A (1) DETERMINES HOW MANY 12.5 MSEC PERIODS
A (2) DETERMINES HOW MANY .625 MSEC PERIODS
*****/
TIMESOUT: CALL TIMER;
GO TO MURERESET;
END

```

ORIGINAL PAGE IS
OF POOR QUALITY

E-8665

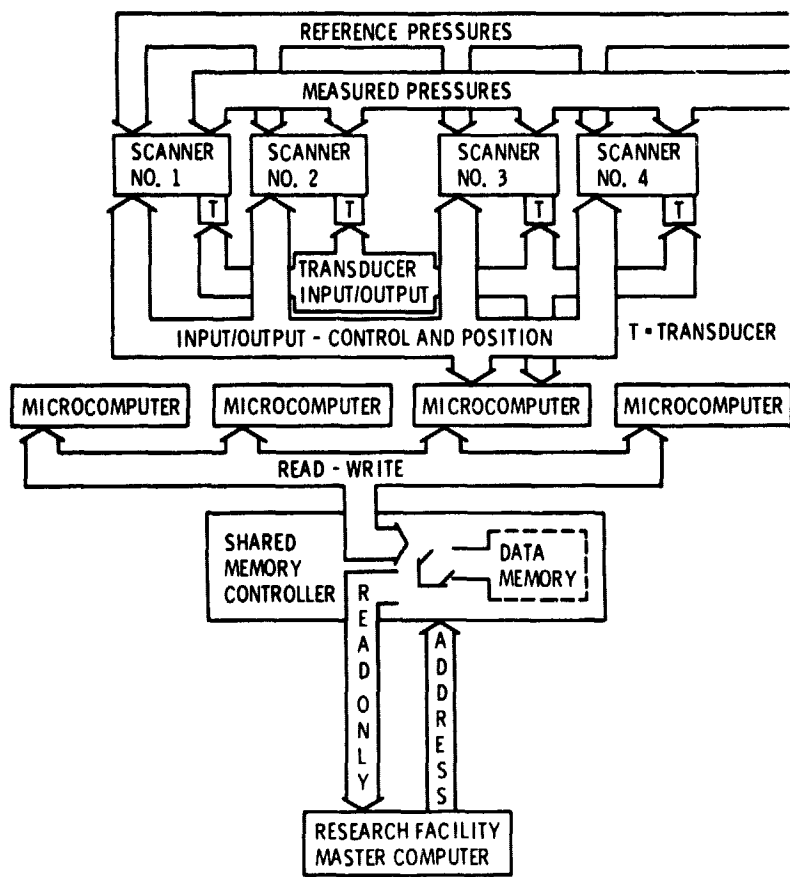

Figure 1. - Block diagram of complete pressure scanning system.

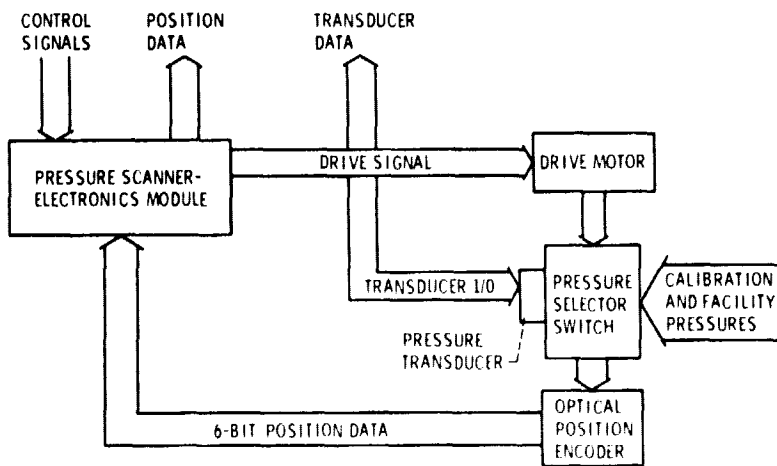

Figure 2. - Block diagram of pressure scanner.

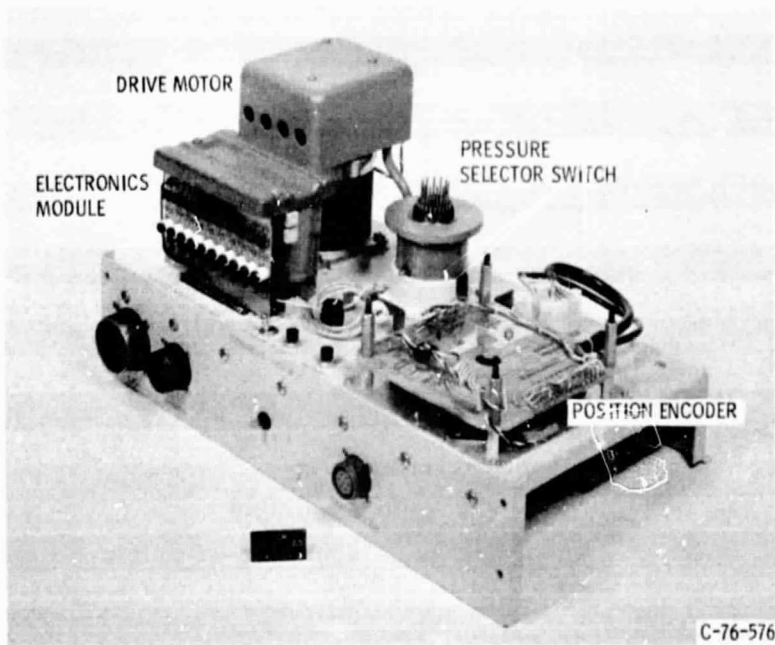

Figure 3. - Pressure scanner chassis.

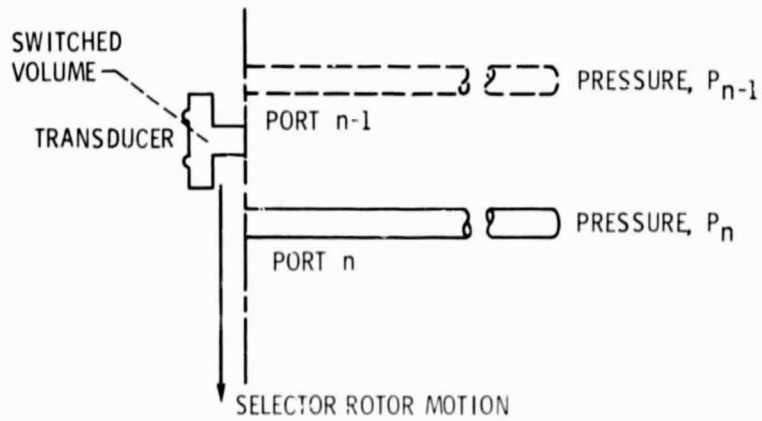

Figure 4. - Pressure selector switch operation.

PRECEDING PAGE BLANK NOT FILMED

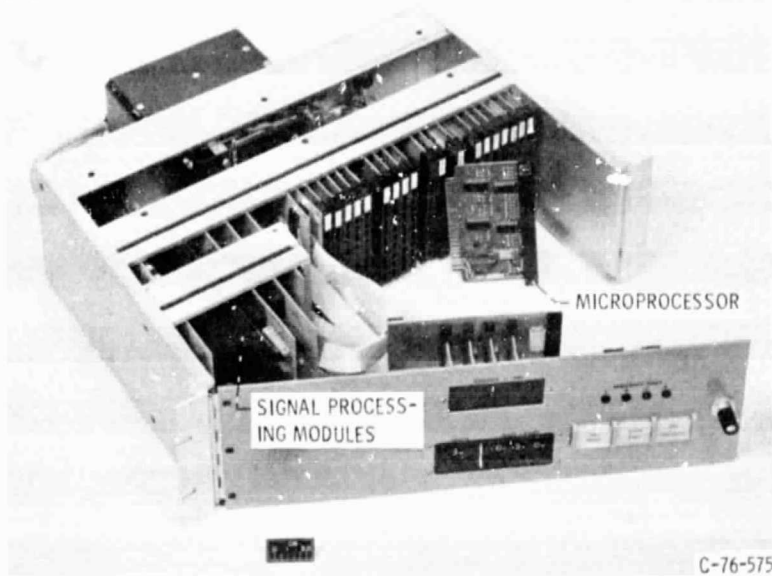

Figure 5. - Microcomputer chassis.

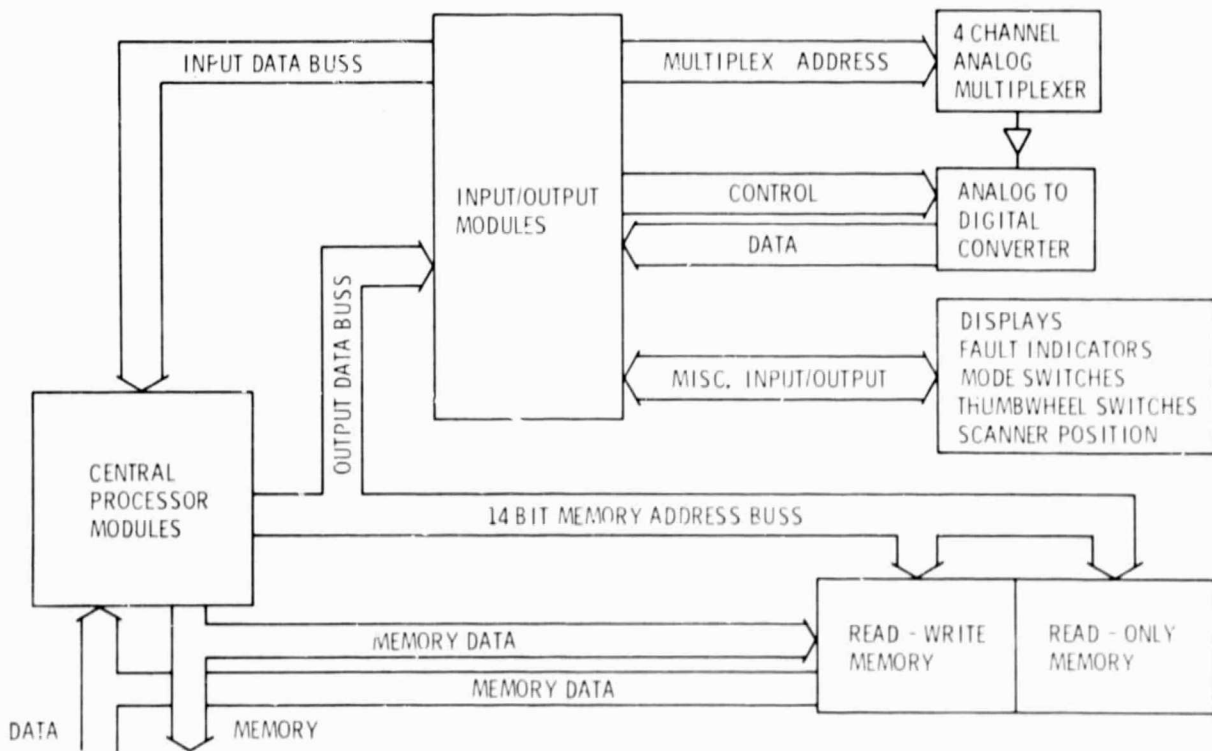

Figure 6. - Microcomputer system block diagram.

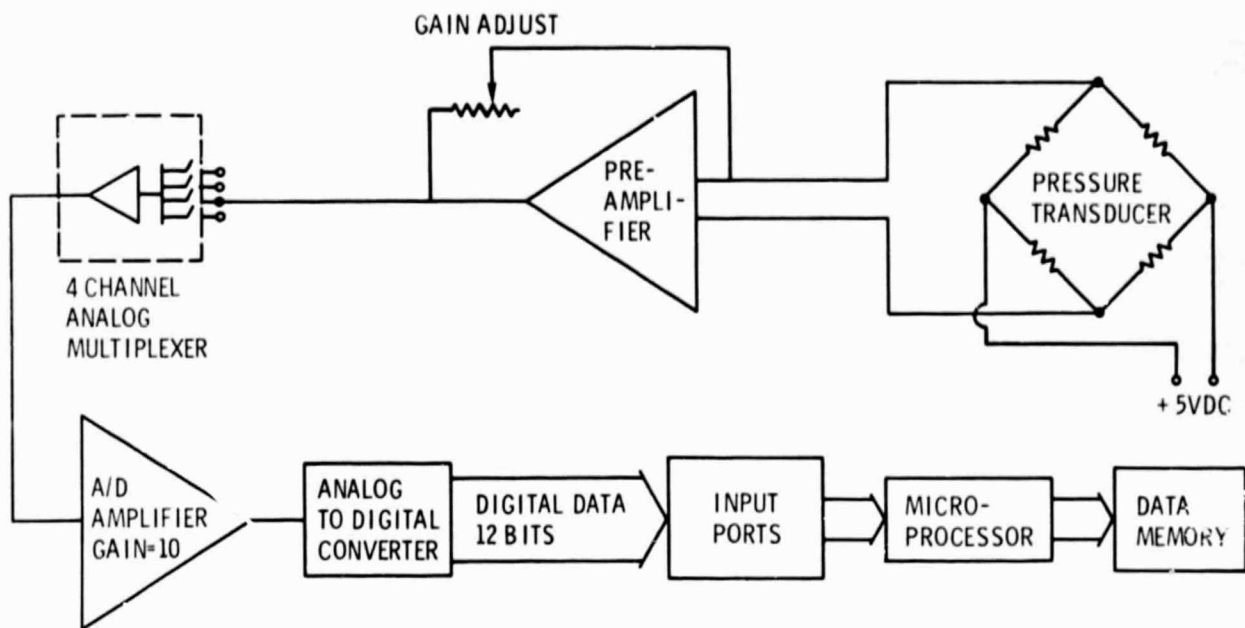

Figure 7. - Pressure scanner transducer data path.

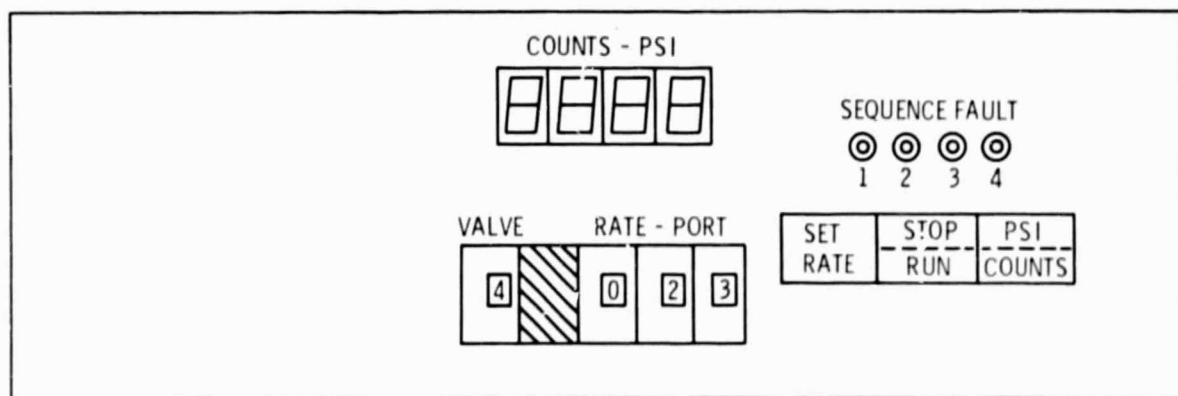

Figure 8. - Front panel of pressure scanner controller.

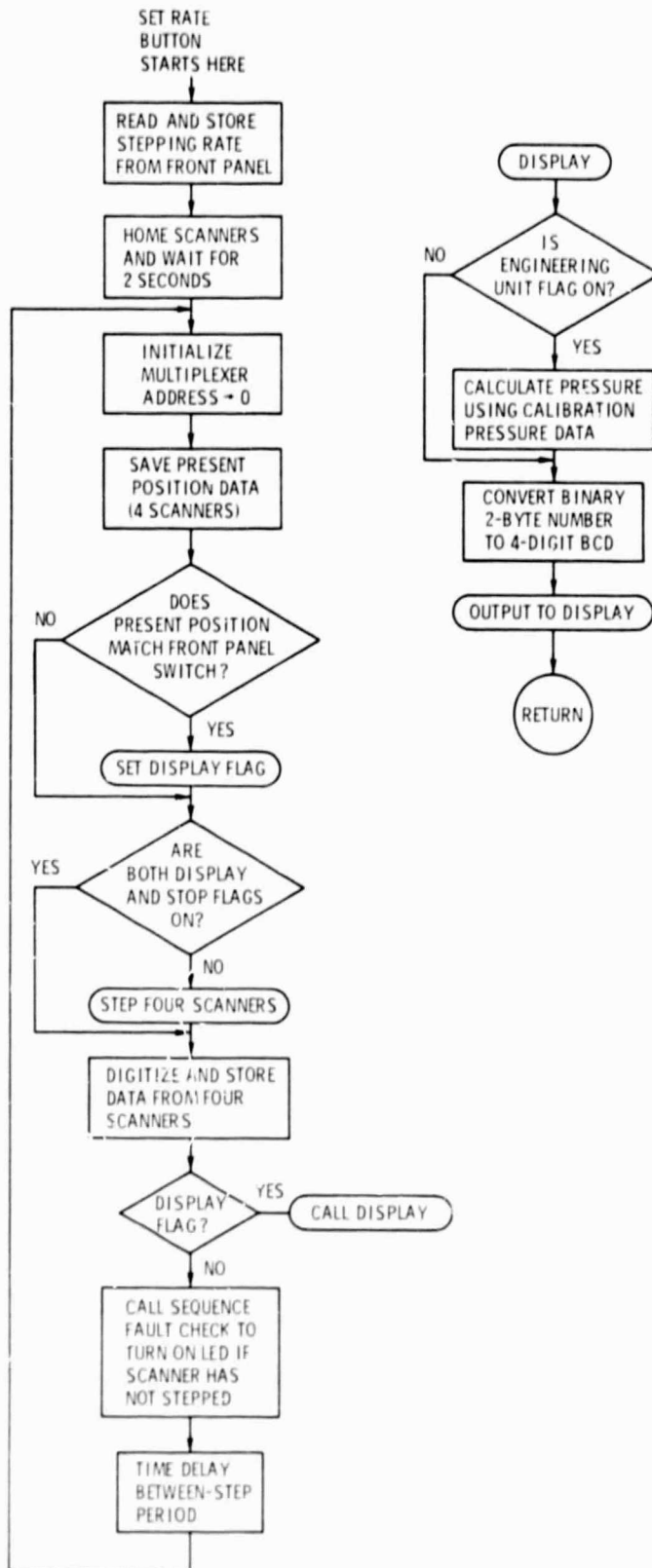

Figure 10. - Flow chart for pressure scanning system controller software.