

General Disclaimer

One or more of the Following Statements may affect this Document

- This document has been reproduced from the best copy furnished by the organizational source. It is being released in the interest of making available as much information as possible.
- This document may contain data, which exceeds the sheet parameters. It was furnished in this condition by the organizational source and is the best copy available.
- This document may contain tone-on-tone or color graphs, charts and/or pictures, which have been reproduced in black and white.
- This document is paginated as submitted by the original source.
- Portions of this document are not fully legible due to the historical nature of some of the material. However, it is the best reproduction available from the original submission.

High Resolution Cerenkov and Range Detectors
for Balloon-Borne Cosmic-Ray Experiment

S.P. Ahlen, B.G. Cartwright, G. Tarlé

Department of Physics
University of California
Berkeley, California 94720

(NASA-CR-146796) HIGH RESOLUTION CERENKOV
AND RANGE DETECTORS FOR BALLOON-BORNE
COSMIC-RAY EXPERIMENT (California Univ.)
21 p HC \$3.50
CACL 03B
G3/93
Unclas
25140
N76-22139

We have proposed a novel combination of an active Cerenkov detector and passive range detectors for the high resolution measurement of isotopic composition in the neighborhood of iron in the galactic cosmic rays.¹ Here we describe tests both of a large area (4300 cm²) Cerenkov counter, and of passive range detectors, built for an experiment based on this principle, the University of California IRIS experiment.² Tests with heavy ions (2.1 GeV/amu C¹², 289 MeV/amu Ar⁴⁰, and 594 MeV/amu Ne²⁰) at the Lawrence Berkeley Bevalac have shown the spatial uniformity of response of the Cerenkov counter to be better than 1% peak-to-peak. Light collection efficiency is independent of projectile energy and incidence angle to within at least 0.5%. We believe this measured uniformity of response as a function of position, energy and angle to be the best reported to date. The counter, a 1.27 cm slab of Pilot 425, produces 35.3 Z² sin² θ_c photoelectrons/cm of Cerenkov signal from the primary ion (i.e., scintillation by the primary or by delta rays, and Cerenkov emission by delta rays are excluded) where Z is the projectile charge number, and θ_c the Cerenkov angle. In addition, using 594 MeV/amu Ne²⁰, we tested the capability of

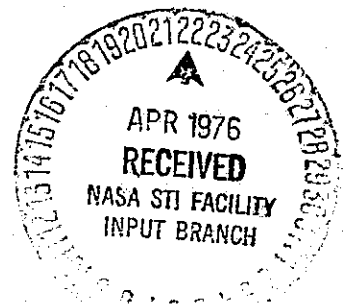

passive Lexan track recorders to measure range in the presence of the nuclear interaction background which results from stopping particles through 0.9 interaction lengths of matter. We find that nuclear interactions produce an effective range straggling distribution only ~75% wider than that expected from range straggling alone. The combination of these tested techniques make possible high mass resolution in the neighborhood of iron. We discuss the implications of these measurements on the expected mass resolution of the IRIS experiment.

Introduction

A Cerenkov detector operated just above threshold provides an accurate means of measuring the velocity of a particle of known charge. At first suggested by us,² when used in conjunction with highly accurate passive range detectors, a Cerenkov counter will measure the velocity to sufficient accuracy to enable the resolution of isotopes differing in mass by as little as 1 amu at iron. The University of California Iron Isotope Experiment, IRIS, described in ref. 1, utilizes a range measurement obtained from a stack of Lexan polycarbonate track recorders. As we will show later in this paper, the accuracy of the range measurement is nearly limited by range straggling (~0.13% for iron nuclei with energies in the vicinity of the Lucite Cerenkov threshold). Hence, the mass resolution one can obtain is limited solely by the resolution of the Cerenkov detector, not by background induced by nuclear interactions, or by intrinsic errors in the measurement of dE/dx , total energy, or rigidity.

Balloon-borne experiments such as ours require large geometrical factors to compensate for relatively short collection times (~50 hours, compared to years for satellites). Thus, to achieve true isotopic resolution one must make the largest Cerenkov counter possible consistent with high resolution and reasonable weight.

In order to obtain a large geometrical factor one generally sacrifices light collection efficiency and spatial uniformity of response, each of which is critical for resolution. Light collection efficiency for both scintillation and Cerenkov counters can be maximized by using total internal reflection (light "piping") to conduct

photons to the photocathode collecting surface of photomultiplier tubes. The spatial uniformity of response in this configuration is often inadequate, however, and a detailed map of the response must be made. Unfortunately, the directional nature of Cerenkov emission leads to the complication of energy- and angle-dependent light collection efficiencies, thereby requiring a five parameter map of response as a function of position, angle, and energy.

By using a diffusing light integration box, which randomizes the Cerenkov photon gas prior to collection, one can solve the problem of spatial non-uniformity, but usually at the expense of light collection efficiency. Highly reflectant diffuse coatings³ can minimize this problem. With such a light box, one can eliminate the difficulties caused by the directionality of Cerenkov light, since roughing up the surface of the radiator effectively eliminates total internal reflection.

Figure 1 shows the arrangement of the counter. The radiator is a 1.27 ± 0.01 cm thick slab of 4300 cm^2 area, consisting of Pilot 425,⁴ a polymethylmethacrylate doped with a wave-shifter (which fluoresces under Cerenkov light thereby extending the usable wavelength range of the Cerenkov emission) and with quenching materials (which minimize the scintillation of the wave-shifter). The radiator sits in a well at the bottom of the box and is packed in on its sides with pure BaSO_4 powder. Sixteen RCA 4525 photomultiplier tubes face upwards into the box so that Cerenkov light must make at least two diffuse reflections before arriving at any tube. The fractional surface area of the interior of the box covered by photocathode faceplate is 4.36%. The surfaces of the box are coated with a highly reflectant BaSO_4 paint³ approximately

250 μm thick. Two layers of Millipore paper⁵ form the reflecting surface under the radiator. The uniform thickness of Millipore paper (as opposed to BaSO_4 painted surfaces) is necessary if particle range is to be measured accurately, a requirement in our experiment.

In order to eliminate the directionality of the Cerenkov light (which is only partially alleviated by the isotropizing wave-shifter), the surfaces of the radiator were sandblasted with 200 grit liquid honing compound. We found that this material produced a surface satisfying our requirements, which were: 1) the size of surface irregularities should be greater than the wavelength of light ($\sim 0.5 \mu\text{m}$); 2) the size of irregularities should be less than $30 \mu\text{m}$ (to avoid errors in range measurement); 3) the surface should be uniformly rough; and 4) the amount of embedded material should be small.

A scanning electron micrograph of the surface appears in Fig. 2. As can be seen, the scale size is about $20 \mu\text{m}$. A scanning X-ray spectrometer revealed the major component of the embedded material to be silicon present at an extremely low level.

Light Box Performance

The absolute reflectivity of the BaSO_4 paint was determined by observing the light from a Pilot F scintillator irradiated by an Am^{241} alpha particle source. The fluorescence spectrum of the scintillator closely matches that of the Pilot 425 radiator and hence provides information relevant to Cerenkov emission. By placing Millipore disks in front of the faceplates of differing numbers of phototubes we were able to obtain 16 data points measuring response as a function of

fraction of box surface area covered by phototube faceplates. The results fit the well-known diffusion box efficiency equation very well:

$$f = \frac{Ft}{1 - (1 - Ft)(1 - a)} \quad (1)$$

where F is the fractional area covered by phototubes, t is the transmittance of the tube window averaged over solid angle, a is the average absorptivity of the box, and f is the light collection efficiency.

In our case, the best fit parameters are: $a = 0.033 \pm 0.002$, $t = 0.69 \pm 0.04$ and $f = 0.476 \pm 0.001$. This result for t is consistent with the quoted value for the index of refraction of the tube window: 1.523. In Fig. 3 we plot the fitted function and the data points. By taking into account the reflectivity of the Millipore paper (95%), a BaSO_4 paint relectivity of 97% is obtained. This is considerably lower than that of pure BaSO_4 powder (99.9%).

Cerenkov Counter Tests with Atmospheric Muons

Vertical muon spectra were obtained both before and after sand-blasting the radiator. A FWHM of 59% was obtained with the smooth surface, and 53%, with the rough surface. Taking into account the 3% standard deviation in $\sec \theta$ due to the angle of incidence distribution of the muons in our test arrangement, and including multidynode counting statistics, we arrive at before and after photoelectron counts of 20 and 25, respectively. These results were confirmed by other methods for determining the number of photoelectrons per muon:

- 1) Counting "misses" on a single tube and using Poisson statistics.⁶

- 2) Using other light sources (an α -source with a scintillator, and a pulsed, green, light-emitting diode) to calibrate the pulse height analyzer in units of photoelectrons.

Cerenkov Counter Tests with Heavy Ions

Spatial uniformity tests were performed with beams at both relativistic energies (C^{12} at 2.1 GeV/amu) and at subthreshold energies (Ar^{40} at 289 MeV/amu). Below threshold only scintillation and Cerenkov light due to secondary electrons contributes to the signal. In both cases the fluctuations in response were no larger than the thickness variations in the radiator. For these tests, smooth radiators were used.

The response of a sandblasted radiator was examined as a function of angle and energy with a Ne^{20} beam at 575 MeV/amu. No deviation from a $\sec \theta$ response was detected for angles from 0° to 45° . For an angle of 0° , energy dependence was investigated by degrading the beam with lead absorbers. A detailed analysis of this response is given in ref. 7. Here it is sufficient to point out that the response is well explained as arising from a combination of three effects:

- 1) Scintillation at a level of 2.7% relative to Cerenkov light at $\beta = 1$.
- 2) Cerenkov light from secondary electrons.
- 3) Cerenkov light from the Ne^{20} ions.

Results from the analysis of ref. 7 indicate that the number of primary Cerenkov photoelectrons per unit length produced by a particle with Z charge units is:

$$\frac{dN_{pe}}{dx} = 35.3 Z^2 \left(1 - \frac{1}{\beta^2 (1.518)^2}\right) \text{ cm}^{-1}, \quad (2)$$

(By primary Cerenkov photoelectrons we mean to exclude the contributions due to Cerenkov emission by delta-rays, and due to scintillation.) The effective index of refraction is 1.518. As pointed out in ref. 7 this value may be predicted from the known optical properties of Pilot 425.

We have been able to fit the data with the Cerenkov law (including a small scintillation component) without invoking any other energy dependent effects. We conclude that the light collection efficiency is independent of energy.

In Fig. 4 we plot the observed response as a function of energy, along with theoretically determined Cerenkov (including delta-ray effects) and scintillation contributions.

We could not determine either by measurement or by theory the fraction of light which escapes the radiator. This parameter is quite dependent on the internal conversion efficiency (by fluorescence) of short wavelength light to light at wavelengths near 425 nm. As a result we cannot quote a value for this important parameter, although a naive calculation in which it is assumed that every photon created between 260 nm and 425 nm is converted to 425 nm gives a value for fractional escape of ~40%. This is undoubtedly lower than the actual value.

In summary, we have constructed and tested a large area Cerenkov intensity counter with desirable properties for large geometrical factor cosmic-ray experiments:

- 1) No dependence of light collection efficiency on particle energy;
- 2) No dependence of light collection efficiency on particle incidence angle;
- 3) Fluctuations in the mean signal as a function of the point at which the particle traverses the detector limited by the thickness variations of the radiator itself, and, in fact, less than 1% peak-to-peak;
- 4) Acceptable light collection efficiency (primary Cerenkov signal = $35.3 Z^2 \sin^2 \theta_c$ photoelectrons/cm);
- 5) Well understood response as a function of energy, both below and above threshold.

The construction technique and design principles we have used are simple and may easily be duplicated.

Range Detection in the Presence of Nuclear Interactions

As we have pointed out,¹ the negligible intrinsic straggling in range of heavy ions^{8,9} makes range an ideal parameter for mass measurement with high resolution. The higher inertia of a more massive ion increases its range relative to the range of a less massive ion of the same charge in direct proportion to the ratio of the masses. Thus, an Fe^{56} will have a range greater than that of an Fe^{55} nucleus with the same initial energy per nucleon in the ratio $56/55 = 1.0182$. The distribution of ranges is nearly Gaussian, with a standard deviation of about 0.13% for iron nuclei at ~400 MeV/nucleon.^{8,9} Thus, neighboring isotopes of iron are separated by 14 standard deviations

in range! Our IRIS experiment,² the first to capitalize on this fact, flew once in the fall of 1974 without returning useable scientific data due to an electronic malfunction. An updated version, IRIS-II, is scheduled for flight during 1976.

The measurement of range requires that a heavy ion be brought to rest. Unfortunately, this cannot be accomplished without a substantial risk of destroying the ion by fragmentation in a nuclear interaction. Thus, a successful experiment based on direct measurement of range must be able to discriminate effectively against those events in which a nuclear interaction occurs. We have proposed the use of passive range detectors because of the high immunity to nuclear interactions which can be achieved with passive techniques. Using a stack of 5 mil sheets of Lexan, for example, means that the charge of a particle being brought to rest can be verified within 5 mils of the end of range point. We have selected Lexan over nuclear emulsions for several reasons: (1) Dimensional Stability. During etching, a Lexan sheet does not shrink or distort. As a result, accurate range measurement is not compromised by shrinkage, as can occur with nuclear emulsions; (2) High "Charge Contrast." If we define charge contrast to be the power of Z to which the detector response is proportional, a saturated scintillator has a contrast of about 1.5, a Cerenkov counter a contrast of 2, while Lexan detectors have a contrast of between 3.5 and 5. This very high contrast implies a high degree of immunity to charge-changing nuclear interactions, since the change in signal between $Z = 25$ and $Z = 26$ is about a 15% effect. In addition, the etch processing can be adjusted to completely eliminate registration of lower charged species,

so that particles which lose more than, say, a few charges, will not record at all; (3) High Homogeneity. Unlike nuclear emulsion, which is a highly heterogeneous mixture and which absorbs water readily, Lexan polycarbonate is composed solely of the polycarbonate ester of 4,4'-diphenyl - 2,2-propane (bisphenol-A), and absorbs negligible quantities of water; and (4) Cost. Lexan is very inexpensive, costing several hundred times less than nuclear emulsion. This translates to the difference between several hundred dollars and many tens of thousands of dollars for a single large area passive range detector.

It is difficult to calculate accurately the actual ease with which the range can be measured in the presence of nuclear interactions. We have, therefore, performed a worst-case test: We have measured the effective width of the range-straggling peak at the end-of-range point of 594 MeV/amu Ne^{20} after passage through 0.5 interaction lengths of lead plus 0.4 interaction lengths of plastic (more interaction lengths than an iron nucleus traverses in coming to rest at the bottom of the IRIS-II range stack) while not performing any measurement of the charge of the particles brought to rest in the plastic. That is, whereas it is possible to check the charge of the particle brought to rest by using the Lexan sheets as a charge detector, in this experiment we measured only the range of the particles, without attempting any measurement of particle charge. A neon which had fragmented to fluorine would, therefore, not be excluded from this analysis.

The results are shown in Fig. 5. The approximate width expected from range straggling not contaminated by interacting particles is shown for comparison. Note that the standard deviation of the measured

distribution (extrapolating to iron) is still only one-tenth the difference in range between Fe^{55} and Fe^{56} .

This means that we can expect, with proper etch time selection, to perform range measurements in the presence of substantial nuclear interaction background without checking nuclear charge near the end of range. This is a remarkable result, which implies that our immunity to nuclear interaction background is much greater than we have previously claimed.^{1,2}

The high degree of immunity arises from two factors. First, the very high charge contrast of Lexan detectors totally prevents the registration of those particles which lose more than a few charges. These particles are lost from analysis, automatically. Second, the occurrence of a charge-changing nuclear interaction tends to greatly alter the range of the remaining particle, making it almost impossible to confuse a particle (whose initial charge and speed have been determined independently) which has interacted with a particle which has not.

In summary, we have confirmed that plastic detectors can perform highly accurate range measurements in the presence of a substantial nuclear interaction background.

Expected Isotopic Resolution of IRIS

By extrapolating our neon results to iron, using the harshest possible scintillation (i.e., assuming that no saturation occurs so that the scintillation scales like Z^2) we can calculate the separation of Cerenkov signals for Fe^{55} and Fe^{56} ions which have the same range.

The ratio of this separation to the photoelectron counting error gives the inverse of the error of our mass measured in amu's. That this is the case requires two assumptions:

- 1) Cerenkov resolution is determined solely by photoelectron statistics.
- 2) The range measurement is much more accurate than the Cerenkov measurement.

Point 1) is supported by the experimental fact that the observed width at $Z = 10$ of the Cerenkov signal is 0.1 that of the observed width at $Z = 1$.

Point 2) has been demonstrated in the previous section.

The above analysis leads us to expect the standard deviation in measured mass to range from $1/3$ amu at 355 MeV/nucleon to $1/2$ amu at 455 MeV/nucleon.

Acknowledgments

We wish to express our appreciation to P. Buford Price for his support of this work, and for the excellent environment for scientific research which exists in his group. We wish to thank Andrew Buffington and Martin Israel for helpful suggestions concerning the construction and testing of Cerenkov counters. We thank the staff of the Lawrence Berkeley Laboratory Bevalac for their kind assistance in arranging for our exposures. We wish to thank D. Braddy for his assistance in producing the scanning electron microscope photographs, and J. Stevenson for processing the Lexan portion of the range experiment. This work was supported by NASA grant NGR 05-003-376.

References

1. S.P. Ahlen, B.G. Cartwright, H. Crawford, P.B. Price, and G. Tarlé, Proc. 14th Inter. Cosmic Ray Conf., Munich, Germany (1975) 3256.
2. S.P. Ahlen, B.G. Cartwright, H. Crawford, P.B. Price, and G. Tarlé, Symposium on Measurements and Interpretation of the Isotopic Composition of Solar and Galactic Cosmic Rays, Durham, New Hampshire (1974).
3. J.B. Schutt, J.F. Arens, C.M. Shai and E. Stromberg, Applied Optics 13 (1974) 2218.
4. Available from Nuclear Enterprises, San Carlos, California.
5. Available from the Millipore Corporation, Bedford, Massachusetts.
6. A. Buffington brought this useful technique to our attention.
7. S.P. Ahlen, B.G. Cartwright and G. Tarlé, submitted to Nucl. Instr. and Meth. (1976).
8. R.M. Sternheimer, Phys. Rev. 117 (1960) 485.
9. Hans Bichsel, in American Institute of Physics Handbook (Dwight E. Gray, ed.; McGraw Hill, 1972) 8-142.

Figure Captions

- Figure 1. Schematic of Cerenkov light integration box. Outside dimensions of box are 102 cm x 102 cm x 38 cm. The 1.27 cm thick Pilot 425 radiator fits in the 65 cm x 65 cm well at the bottom of the box. The top is a 1 mm sheet of aluminum and the sides are 3.2 mm aluminum. The walls and top are coated with BaSO_4 paint. Two layers of Millipore paper are placed beneath the radiator, which is supported by a low porosity aluminum plate of precise thickness.
- Figure 2. Scanning electron micrograph of the surface of the Pilot 425 radiator after being sandblasted with 200 grit liquid honing compound.
- Figure 3. Plot of the amount of light collected by the Cerenkov light integration box as a function of tube fractional area covered. An Am^{241} α -source irradiated a Pilot F scintillator to provide the light source. The curve is the best fit diffusion box efficiency function to the data.
- Figure 4. Observed response of the Cerenkov radiator as a function of incident energy. The theoretical pure Cerenkov response and the scintillation component are plotted separately.
- Figure 5. Observed number of stopping particles as a function of depth of Lexan stack. Each sheet in the Lexan stack was 0.005 inch thick. These events include stopping fluorine and oxygen ions as well as the Ne^{20} beam particles (at an incident energy of 594 MeV/amu). The observed FWHM is 15 sheets. For comparison, a range straggling curve due to energy loss

fluctuations alone is presented.^{8,9} The FWHM of this
curve is 8.68 sheets.

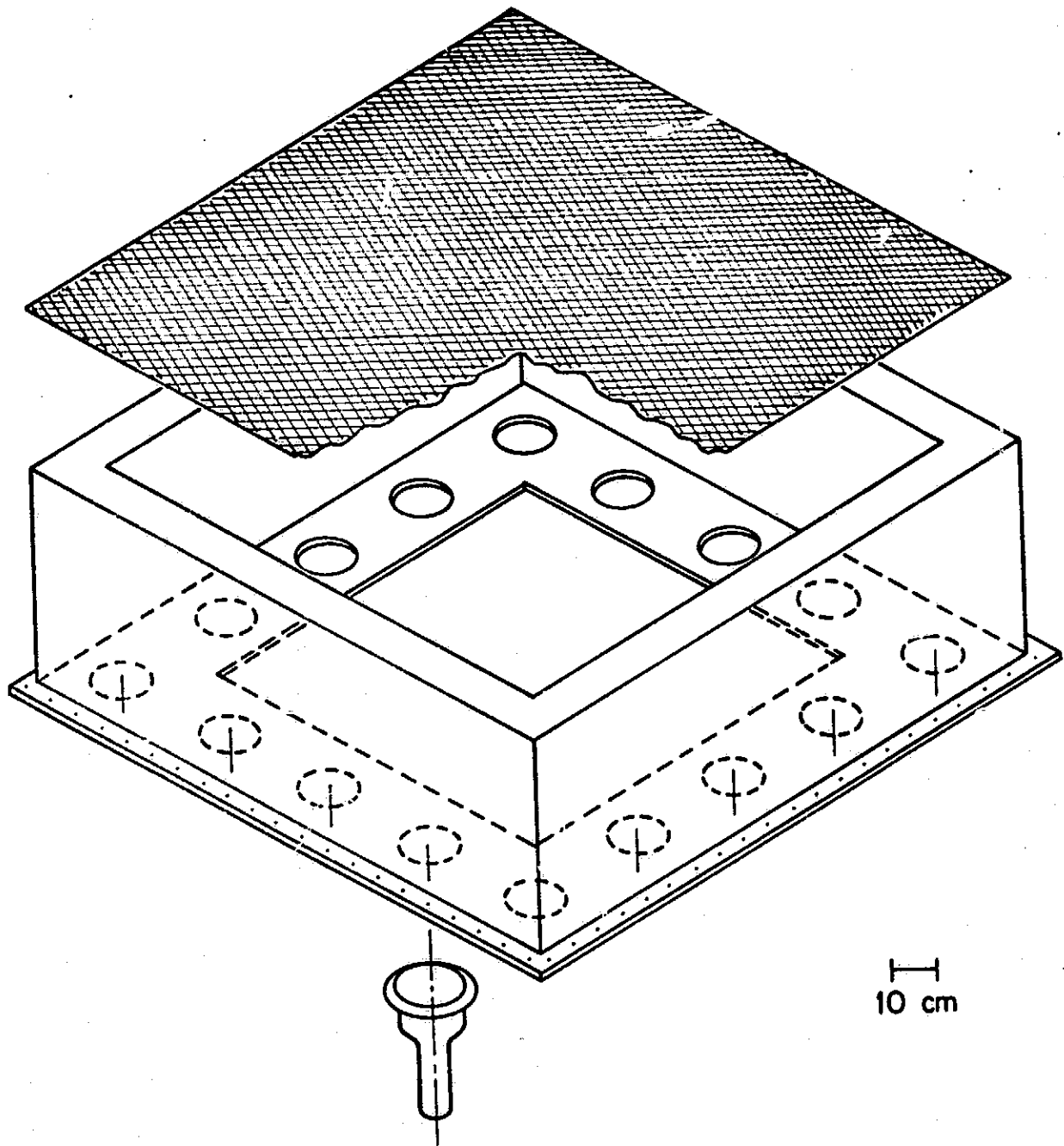

REPRODUCIBILITY OF THE ORIGINAL PAGE IS POOR.

REPRODUCIBILITY OF THE
ORIGINAL PAGE IS POOR

