

JSC-09811

DETAILED REQUIREMENTS DOCUMENT FOR THE
INTEGRATED STRUCTURAL ANALYSIS SYSTEM
(PHASE B)

NASA CR-

147550

Job Order 84-157

(NASA-CR-147550) DETAILED REQUIREMENTS
DOCUMENT FOR THE INTEGRATED STRUCTURAL
ANALYSIS SYSTEM, PHASE B (Lockheed
Electronics Co.) 632 P HC \$16.25 CSCI 13M

N76-22584

Unclas
63/39 27403

Prepared By

Lockheed Electronics Company, Inc.
Aerospace Systems Division
Houston, Texas
Contract NAS 9-12200

For
INSTITUTIONAL DATA SYSTEMS DIVISION

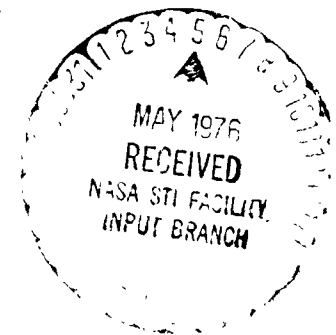
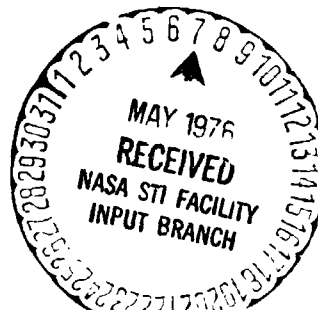

National Aeronautics and Space Administration
LYNDON B. JOHNSON SPACE CENTER

Houston, Texas

January 1976

LEC-5809

JSC-09811

Detailed Requirements Document
for the
Integrated Structural Analysis System (ISAS)
Phase B
Job Order 84-15

Prepared by:



John A. Ranney, Supervisor
Software Integration Section
Applied Mechanics Department

LEC

NASA



R. T. Theobald, Manager
Applied Mechanics Department



J. L. Raney, Technical Monitor
Scientific Computing Branch

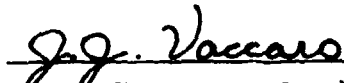

J. J. Vaccaro, Assistant Director
Scientific Applications Branch

 3-5-76

C. F. Malone, Chief
Scientific Computing Branch

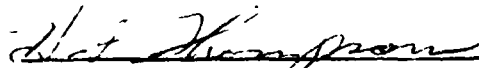

H. F. Thompson, Director
Software Applications Branch

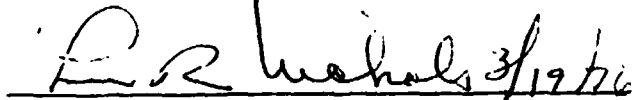
 3/19/76

L. R. Nichols, DSAD
Technical Manager

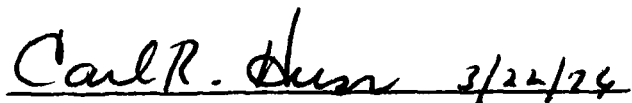
 3/22/76

C. R. Huss
Institutional Data Systems Division

Prepared by
Lockheed Electronics Company, Inc.
for
Institutional Data Systems Division
National Aeronautics and Space Administration
Lyndon B. Johnson Space Center
Houston, Texas
February 1976

CONTENTS

Section	Page
1. PURPOSE AND SCOPE	i-1
2. SYSTEM OVERVIEW	2-1
2.1 <u>BACKGROUND</u>	2-1
2.2 <u>GENERAL DESCRIPTION</u>	2-2
2.3 <u>ASSUMPTIONS AND CONSTRAINTS</u>	2-5
3. OPERATIONAL REQUIREMENTS	3-1
3.1 <u>USER INTERFACE</u>	3-1
3.2 <u>HARDWARE/SOFTWARE CONFIGURATION</u>	3-3
3.3 <u>APPLICATIONS INTERFACE REQUIREMENTS</u>	3-5
4. ISAS FUNCTION REQUIREMENTS	4-1
4.1 <u>AERODYNAMIC AND INERTIAL LOADS</u>	4-1
4.1.1 FORCE INPUTS TO INTERNAL LOADS ANALYSIS	4-1
4.1.2 BODY LOADS ANALYSIS	4-4
4.2 <u>AERODYNAMIC DATA BASE GENERATOR</u>	4-21
4.2.1 PURPOSE	4-21
4.2.2 INPUT	4-21
4.2.3 PROCESSING	4-22
4.2.4 OUTPUT	4-22
4.3 <u>AERODYNAMIC LOADS</u>	4-28
4.3.1 PURPOSE	4-28
4.3.2 INPUT	4-28
4.3.3 PROCESSING	4-29
4.3.4 OUTPUT	4-30

Section	Page
4.4 <u>AIRCRAFT FLIGHT CONDITIONS.</u>	4-33
4.4.1 PURPOSE	4-33
4.4.2 INPUT	4-33
4.4.3 PROCESSING.	4-33
4.4.4 OUTPUT.	4-35
4.5 <u>AIRCRAFT GUST AND BOOST TURBULENCE LOADS.</u>	4-41
4.5.1 PURPOSE	4-41
4.5.2 INPUT	4-41
4.5.3 PROCESSING.	4-41
4.5.4 OUTPUT.	4-43
4.6 <u>AERODYNAMIC CALCULATIONS FOR WING AND BODY ELEMENTS.</u>	4-49
4.6.1 PURPOSE	4-49
4.6.2 INPUT	4-49
4.6.3 PROCESSING.	4-49
4.6.4 OUTPUT.	4-53
4.7 <u>BASIC GEOMETRY FILE GENERATOR</u>	4-55
4.7.1 PURPOSE	4-55
4.7.2 INPUT	4-55
4.7.3 PROCESSING.	4-56
4.7.4 OUTPUT.	4-60
4.8 <u>BASIC STRUCTURAL DIMENSIONS</u>	4-63
4.8.1 PURPOSE	4-63
4.8.2 INPUT	4-63
4.8.3 PROCESSING.	4-63
4.8.4 OUTPUT.	4-65

Section	Page
4.9 <u>BOOST FLIGHT CONDITIONS</u>	4-85
4.9.1 PURPOSE	4-85
4.9.2 INPUT	4-85
4.9.3 PROCESSING.	4-86
4.9.4 OUTPUT.	4-87
4.10 <u>DYNAMIC LOADS.</u>	4-91
4.11 <u>ELEMENT PROPERTY FILE GENERATOR.</u>	4-92
4.11.1 PURPOSE.	4-92
4.11.2 INPUT.	4-92
4.11.3 PROCESSING	4-92
4.11.4 OUTPUT	4-93
4.12 <u>FATIGUE ASSESSMENT</u>	4-95
4.12.1 PURPOSE.	4-95
4.12.2 INPUT.	4-95
4.12.3 PROCESSING	4-95
4.12.4 OUTPUT	4-103
4.13 <u>FLIGHT CONDITIONS MERGE.</u>	4-105
4.13.1 PURPOSE.	4-105
4.13.2 INPUT.	4-105
4.13.3 PROCESSING	4-105
4.13.4 OUTPUT	4-107
4.14 <u>FLIGHT CONDITIONS FILE REDUCTION</u>	4-109
4.14.1 PURPOSE.	4-109
4.14.2 INPUT.	4-109
4.14.3 PROCESSING	4-109

Section	Page
4.14.4 OUTPUT	4-110
4.15 <u>INTERNAL LOADS AND DYNAMIC CHARACTERISTICS</u> . . .	4-112
4.15.1 PURPOSE.	4-112
4.15.2 NASA STRUCTURAL ANALYSIS SYSTEM (NASTRAN). . .	4-112
4.15.3 ANALYSIS OF AEROSPACE STRUCTURES BY THE DISPLACEMENT METHOD (AIR FORCE PROGRAM). . . .	4-129
4.15.4 AUTOMATED STRUCTURAL OPTIMIZATION PROGRAM (ASOP)	4-134
4.16 <u>LANDING FLIGHT CONDITIONS.</u>	4-166
4.17 <u>LIFTING SURFACE FLUTTER/UNSTEADY AERODYNAMIC FORCES</u>	4-167
4.17.1 UNSTEADY AERODYNAMIC FORCES.	4-167
4.17.2 LIFTING SURFACE FLUTTER.	4-171
4.18 <u>LOAD COEFFICIENT GENERATOR</u>	4-186
4.18.1 PURPOSE.	4-186
4.18.2 INPUT.	4-186
4.18.3 PROCESSING	4-186
4.18.4 OUTPUT	4-211
4.19 <u>MATERIAL DATA FILE GENERATOR</u>	4-214
4.19.1 PURPOSE.	4-214
4.19.2 INPUT.	4-214
4.19.3 PROCESSING	4-214
4.19.4 OUTPUT	4-216
4.20 <u>MOTION PICTURE GENERATOR</u>	4-221
4.20.1 PURPOSE.	4-221
4.20.2 MOVIE SUBFUNCTION.	4-221
4.20.3 SC-4060 MICROFILM SUBFUNCTION.	4-222

Section	Page
4.21 <u>MODEL MATERIAL FILE GENERATOR.</u>	4-224
4.21.1 PURPOSE.	4-224
4.21.2 INPUT.	4-224
4.21.3 PROCESSING	4-224
4.21.4 OUTPUT	4-227
4.22 <u>MODEL TEMPERATURE FILE GENERATOR</u>	4-230
4.22.1 PURPOSE.	4-230
4.22.2 INPUT.	4-230
4.22.3 PROCESSING	4-230
4.22.4 OUTPUT	4-231
4.23 <u>NASTRAN POSTPROCESSING</u>	4-233
4.23.1 PURPOSE.	4-233
4.23.2 INPUT.	4-233
4.23.3 PROCESSING	4-233
4.23.4 OUTPUT	4-244
4.24 <u>PANEL FLUTTER.</u>	4-247
4.24.1 PURPOSE.	4-247
4.24.2 INPUT.	4-247
4.24.3 PROCESSING	4-247
4.24.4 OUTPUT	4-250
4.25 <u>POGO STABILITY</u>	4-252
4.25.1 PURPOSE.	4-252
4.25.2 INPUT.	4-252
4.25.3 PROCESSING	4-252
4.25.4 OUTPUT	4-254

Section	Page
4.26 <u>PROPERTIES AND ALLOWABLES.</u>	4-260
4.26.1 PURPOSE.	4-260
4.26.2 INPUT.	4-260
4.26.3 PROCESSING	4-260
4.26.4 OUTPUT	4-285
4.27 <u>RANDOM VIBRATION ANALYSIS.</u>	4-316
4.28 <u>STATIC AEROELASTICITY.</u>	4-317
4.28.1 PURPOSE.	4-317
4.28.2 INPUT.	4-317
4.28.3 PROCESSING	4-318
4.28.4 OUTPUT	4-321
4.29 <u>TWO-BODY SEPARATION.</u>	4-331
4.30 <u>THREE-BODY SEPARATION.</u>	4-332
4.31 <u>USER MODEL FILE GENERATOR.</u>	4-333
4.31.1 PURPOSE.	4-333
4.31.2 INPUT.	4-333
4.31.3 PROCESSING	4-334
4.31.4 OUTPUT	4-338
4.32 <u>MODEL WEIGHT FILE GENERATOR.</u>	4-357
4.32.1 PURPOSE.	4-357
4.32.2 INPUT.	4-357
4.32.3 PROCESSING	4-357
4.32.4 OUTPUT	4-368
4.33 <u>VENTING ANALYSIS</u>	4-370
4.33.1 PURPOSE.	4-370

Section	Page
4.33.2 INPUT	4-370
4.33.3 PROCESSING	4-370
4.33.4 OUTPUT	4-370
5. PERFORMANCE REQUIREMENTS	5-1
5.1 <u>RESPONSE TIME</u>	5-1
5.2 <u>AVAILABILITY</u>	5-2
5.3 <u>STABILITY/RELIABILITY</u>	5-2
5.4 <u>HUMAN FACTORS</u>	5-3
6. IMPLEMENTATION	6-1
6.1 <u>DATA BASE ESTABLISHMENT</u>	6-1
6.2 <u>OPERATIONAL STAGES</u>	6-1



TABLES

Table		Page
4.4-1	AIRCRAFT MANEUVERS PROGRAM PLOT CAPABILITIES . . .	4-40
4.9-1	AVAILABLE PLOTS FOR BOOST FLIGHT CONDITIONS FUNCTION.	4-89
4.15-1	STANDARD MATERIALS	4-165
4.19-1	SAMPLE TABLE OF CONTENTS	4-219
4.19-2	SAMPLE OF TABULAR DATA	4-220
4.21-1	MATERIAL DATA REQUIRED VERSUS PROBLEM DESCRIPTIONS	4-229
4.26-1	PARAMETERS FOR LOCAL BUCKLING.	4-302
4.26-2	BUCKLING COEFFICIENT FOR INFINITE PLATES IN COMPRESSION	4-304
4.26-3	PANEL CRIPPLING STRESS RELATIONS	4-305
4.26-4	BUCKLING COEFFICIENT FOR INFINITE PLATES IN SHEAR	4-307
4.26-5	PARAMETERS FOR SHEAR BUCKLING.	4-308
4.26-6	PARAMETERS FOR PANEL SECTION PROPERTIES.	4-310
4.26-7	COLUMN FIXITY COEFFICIENTS	4-314
4.26-8	INTERACTION EQUATIONS.	4-315

...ING PAGE BLANK NOT FILMED

FIGURES

Figure		Page
2.1-1	Integrated Structural Analysis System operational concept	2-4
3.1-1	Sample of dialogue between user and machine . . .	3-4
4.1-1	Data flow diagram for Aerodynamic Inertial Loads function.	4-11
4.1-2	Differential pressure versus Mach number.	4-14
4.1-3	Differential pressure versus X vehicle station. .	4-15
4.1-4	Vehicle cross section at a given X station. . . .	4-16
4.1-5	Differential pressure versus time	4-17
4.1-6	Display for both maximum and minimum ordered loads	4-18
4.1-7	Display for one set of ordered loads.	4-19
4.1-8	Loads matrix output format.	4-20
4.2-1	Data flow diagram for Aerodynamic Data Base Generator.	4-24
4.2-2	Tabulation of SADSAC data	-25
4.2-3	Longitudinal pressure distribution of the fuselage, neutral rudder, and elevator.	4-26
4.2-4	Example of tabular display of force and moment totals	4-27
4.3-1	Data flow diagram for Aerodynamic Loads	4-31
4.4-1	Data flow diagram for Aircraft Flight Conditions	4-36
4.4-2	Display example for Aircraft Flight Conditions function	4-37
4.4-3	Example curve for alpha versus C_A for each beta	4-38

Figure		Page
4.4-4	Output tabulation example of all parameters calculated at a particular time interval	4-39
4.5-1	Data flow diagram for Aircraft Gust and Boost Turbulence Loads.	4-44
4.5-2	Force Coefficient Data File tabulation format	4-46
4.5-3	Generalized force matrix example.	4-47
4.5-4	Tabulations and graphics displayed for the Response Output File.	4-48
4.6-1	Data flow diagram for Aerodynamic Calculations for Wing and Body Elements.	4-54
4.7-1	Data flow diagram for Basic Geometry File Generator.	4-61
4.7-2	Examples of display selectable input.	4-62
4.8-1	Data flow diagram for Basic Structural Dimensions.	4-66
4.8-2	Generalized stiffened panel concept	4-67
4.8-3	Beam concept.	4-68
4.8-4	Sixteen stiffened panel configurations.	4-69
4.8-5	Example of tabular format for panels.	4-74
4.8-6	Example of beam tabular format.	4-80
4.8-7	Typical beam elements	4-81
4.8-8	Example of a panel tabular format	4-84
4.9-1	Data flow diagram for Boost Flight Conditions	4-88
4.10-1	Data flow diagram for Dynamic Loads	4-91
4.11-1	Data flow diagram for Element Property File Generator.	4-94
4.12-1	Data flow diagram for Fatigue Assessment.	4-104
4.13-1	Data flow diagram for Flight Conditions Merge	4-108



Figure		Page
4.14-1	Data flow diagram for the Flight Conditions File Reduction function	4-111
4.15-1	Data flow diagram for Internal Loads and Dynamic Characteristics	4-161
4.15-2	Example tabulation of force and moment cards. . .	4-162
4.15-3	Construction of input deck.	4-163
4.15-4	Member data card format	4-164
4.16-1	Data flow diagram for Landing Flight Conditions	4-166
4.17-1	Data flow diagram for Lifting Surface Flutter/ Unsteady Aerodynamic Forces	4-175
4.17-2	Example of downwash distribution tabulation format.	4-177
4.17-3	Example of unsteady aerodynamic influence coefficients tabulation format.	4-178
4.17-4	Example of pressure distribution tabulation format.	4-179
4.17-5	Example of generalized forces tabulation format	4-180
4.17-6	Example of area matrix tabulation format.	4-181
4.17-7	Example of chordwise plot	4-182
4.17-8	Format for tabulation of flutter solution data. .	4-183
4.17-9	Example of flutter mode shape data.	4-184
4.17-10	Example of Mach number versus dynamic pressure plot	4-185
4.18-1	Data flow diagram for Load Coefficient Generator	4-212
4.18-2	LG-matrix format.	4-213
4.19-1	Data flow diagram for Material Data File Generator	4-217

Figure		Page
4.19-2	Sample of curve data.	4-218
4.20-1	Data flow diagram for Motion Picture Generator.	4-223
4.21-1	Data flow diagram for Model Material File Generator.	4-228
4.22-1	Data flow diagram for Model Temperature File Generator.	4-232
4.23-1	Data flow diagram for NASTRAN Postprocessing.	4-246
4.24-1	Data flow diagram for Panel Flutter	4-251
4.25-1	Data flow diagram for POGO Stability.	4-255
4.25-2	Node identification display	4-256
4.25-3	Mode versus frequency display	4-256
4.25-4	Display of modal gain for selected degree of freedom.	4-257
4.25-5	Display of ordered mode save array according to number of occurrences.	4-257
4.25-6	Display of selected modal data.	4-258
4.25-7	Frequency versus damping display.	4-258
4.25-8	Eigenvector display	4-259
4.26-1	Data flow diagram for Properties and Allowables.	4-288
4.26-2	Example of tabulation format for Interim Properties and Allowables File.	4-290
4.26-3	Compressive buckling coefficients for flat plates	4-291
4.26-4	Trapezoidal corrugation local compressive buckling coefficient.	4-292
4.26-5	Compressive buckling coefficient for hat stiffeners based on constant t_w geometry parameter	4-293
4.26-6	Compressive buckling coefficient for cylinders.	4-294

Figure	Page
4.26-7	Shear buckling coefficient for flat plates. 4-295
4.26-8	Example of beam calculations. 4-296
4.26-9	Torsion factor for rectangular elements 4-297
4.26-10	Example of column allowable curve 4-298
4.26-11	Stiffened panel concept 4-299
4.26-12	Beam concept. 4-300
4.26-13	Example of interaction curve for combined shear and bending 4-301
4.27-1	Data flow diagram for Random Vibration Analysis. 4-316
4.28-1	Data flow diagram for Static Aeroelasticity . . . 4-322
4.28-2	Example of geometry data tabulation 4-324
4.28-3	Example of matrix of structural slopes. 4-325
4.28-4	Example plot of structural slopes versus chord at each span station. 4-326
4.28-5	Static Aeroelasticity Output File tabulation. . . 4-327
4.28-6	Example plot of aerodynamic panel coordinates . . 4-328
4.28-7	Example plot of structural slope. 4-329
4.28-8	Example plot of rigid pressure coefficients . . . 4-330
4.29-1	Data flow diagram for Two-Body Separation 4-331
5.30-1	Data flow diagram of Three-Body Separation. . . . 4-332
4.31-1	Data flow diagram for User Model File Generator. 4-349
4.31-2	Sample traces 4-356
4.32-1	Data flow diagram for Model Weight File Generator. 4-369
4.33-1	Data flow diagram for Venting Analysis. 4-373

Figure		Page
4.33-2	Example tabulation of pressure coefficients for several angles of sideslip.	4-374
4.33-3	Example tabulation of pressure coefficients for many angles of attack	4-374
4.33-4	Example tabulation of pressure coefficients for several Mach numbers.	4-375
4.33-5	Example of plot for pressure versus Mach.	4-376
4.33-6	Example of plot for pressure versus X vehicle station	4-377
4.33-7	Example of plot for vehicle cross section at a given X station.	4-378
4.33-8	Example of plot for pressure versus time.	4-379
4.33-9	Example tabulation of VADIC output data	4-380
4.33-10	Example tabulation for cell pressure versus time.	4-380

ACRONYMS

ACE	Analytic Pressure Distribution Program
ASOP	Automated Structural Optimization Program
CRT	Cathode-ray tube
ES2	JSC Structures Branch
ET	External tank
FD3	JSC Scientific Computing Branch
FDSET	Force data sets
FINDRUN	EXEC 8 feature used to check status of batch jobs
FMILL	Milling machine lofting routine
FOCAP	Aerodynamic Force Coefficient Program
FRISBE	Dynamic Modal Response Program
[G]	Geometry matrix
ID	Identification
IDS	JSC Institutional Data Systems Division
ISAS	Integrated Structural Analysis System
JSC	Lyndon B. Johnson Space Center
LEC	Lockheed Electronics Company, Inc.
LDSET	Local loads data sets
NAMELIST	FORTRAN defined input format
NAPSAP	NASA POGO Stability Program
NASA	National Aeronautics and Space Administration
NASTOF	NASTRAN to FRISBE Modal Tape Conversion Program
NASTRAN	NASA Structural Analysis Program
NRDBOK	North American Rockwell Deblock Program
NTRAN	UNIVAC Systems buffered input/output routine

POGO Self-excited longitudinal oscillations observed in
 boost phase of various types of liquid propellant
 launch vehicles

PSD Power spectral density

PSMC Propulsion System Model Characteristics Program

REFOR Flight Conditions Reformat Function

rms Root mean square

RSS Root summed square

SADSAC System for Automatic Development of Static Aerothermo-
 dynamic Criteria

SAMIS Structural Analysis and Matrix Interpretive Program

SAP Structural Analysis Program

SATOF SAMIS to FRJSBE Program

SCRIBL Scale Rigid Body Loads Program

SPC Single point constraint

SPL Sound pressure level

SPP Stability Preprocessor Program

SRB Solid rocket booster

STAC Static Aeroelasticity Correction Program

STAP Static Aeroelasticity Program

SUP Standard unit of processing

TBD To be determined

TPS Thermal Protection System

VADIC Venting Analysis Digital Computer Program

SYMBOLS

A	Area
[A]	Coefficient matrix
a/b	Element aspect ratio
A_{st}	Area of stiffener
b_s	Stiffener spacing
C	Speed of sound in Panel Flutter function
C	Column end fixity coefficient in Properties and Allowables function
C_p	Pressure coefficient
E	Young's modulus
[EBLC]	Required output matrix
EC	Transverse compression modulus
E_s	Material secant modulus
E_t	Material tangent modulus
eTU	Ultimate longitudinal strain
F	Configuration cut-off stress
F_b	Allowable bending stress
FC	Local buckling stress
F_c	Allowable compressive stress
FCC	Crippling allowable stress
FC_{ss}	Local buckling stress of skin between stiffeners
FCU	Ultimate compression stress
FISU	Interlaminar shear ultimate
f_n	Fundamental frequency
F_p	Allowable stress due to pressure

FS	Material shear allowable stress
F_s	Allowable shear stress
FSU	In-plane shear ultimate
F_t	Allowable tension stress
F_{tor}	Allowable torsion stress
FTU	Ultimate tensile stress
G	Shear modulus
[G]	Geometry matrix
GMASS	Generalized mass
$G_p(f_n)$	Spectral density
I	Moment of inertia in Fatigue Assessment function
I1	Moment of inertia about first plane
I2	Moment of inertia about second plane
[I]	Unit matrix in Model Weight File Generator function
J	Torsional Constant
K1	Shear area factor about first plane
K2	Shear area factor about second plane
K_c	Compressive buckling coefficient
K_s	Panel shear buckling coefficient
K_T	Notch factor
L	Length
[L]	Load matrix
LW	Lumped weight
L/ρ	Slenderness ratio
L/ρ_{st}	Slenderness ratio of stiffeners
M	Mach number
[M]	Full mass matrix

[MTEF]	Required output matrix
n	Number or curve shape factor
NDF	Number of degrees of freedom
N_R	Cycles to failure
ρ_a	Air density
P_{CR}	Calculated allowable force
P_∞	Ambient pressure
q	Dynamic pressure
R	Radius
t	Thickness
T_{avg}	Element temperature
$[T_R]$	Transformation matrix
V	Free-stream velocity
W	Weight
Z	Effective skin width parameter
α	Angle of attack
β	Angle of sideslip
γ	Section property
$\Delta\epsilon$	Elevon deflection
ΔP	Differential pressure
Δr	Rudder deflection
δ	Damping ratio
η	Plasticity correction factor
$\bar{\eta}$	Plasticity correction factor (circle)
λ	Direction cosines of vehicle and reference line coordinate systems

λ_{OF}	Direction cosines of inertial and reference line coordinate systems
μ	Poisson's ratio
ρ	Radius of gyration in Properties and Allowables function
ρ	Density in Material Data File Generator function
σ_{rms}	Root mean square stress
σ_{CR}	Column allowable stress
ϕ	Angular position on fuselage about X-axis

1. PURPOSE AND SCOPE

This document defines the requirements for a software system entitled Integrated Structural Analysis System (ISAS) Phase B. This system is being developed to provide the user with a tool by which a complete and detailed analysis of a complex structural system can be performed in a more efficient manner. This software system will allow for automated interface with numerous structural analysis batch programs and for user interaction in the creation, selection, and validation of data. This system will include modifications to the 4 functions developed for ISAS Phase A and the development of 25 new functions. The new functions are:

- Aerodynamic Calculations for Wing and Body Elements
- Aircraft Flight Conditions
- Aircraft Gust and Boost Turbulence Loads
- Basic Structural Dimensions
- Boost Flight Conditions
- Element Property File Generator
- Fatigue Assessment
- Flight Conditions Merge
- Flight Conditions File Reduction
- Internal Loads and Dynamic Characteristics
- Lifting Surface Flutter/Unsteady Aerodynamic Forces
- Load Coefficient Generator
- Material Data File Generator
- Model Material File Generator
- Model Temperature File Generator
- Panel Flutter

- POGO Stability
- NASA Structural Analysis Program (NASTRAN) postprocessing
- Properties and Allowables
- Random Vibration Analysis
- Static Aeroelasticity
- Venting Analysis
- User Model File Generator
- Model Weight File Generator
- Motion Picture Generator

Technical requirements for this system originate from the Structures Branch (ES2). The total system will be developed under two job orders. Of primary interest for this document is the interactive system to be developed under job order 84-157, Integrated Structural Analysis System (ISAS) Design, which is issued by the Scientific Computing Branch (FD3). Various data analysis programs will be referred to throughout this document. These programs are being developed under category 1, job order 81-077, which is the responsibility of the Structures Branch (ES2).

2. SYSTEM OVERVIEW

The Integrated Structural Analysis System (ISAS) is defined by 33 unique functions plus supporting subroutines, such as interpolation and matrix manipulation routines. The software development of ISAS has been divided into two phases, Phase A and Phase B. Phase A, the first to be developed, is defined by four ISAS functions and a minimum graphics requirement. The four Phase A functions are: (1) Aerodynamic and Inertial Loads, (2) Basic Geometry File Generator (no interactive graphics), (3) Aerodynamic Data Base Generator, and (4) Aerodynamic Loads. The requirements for these functions are described in the *Detailed Requirements Document For Integrated Structural Analysis System (Phase A)*, LEC-0869. These same four functions are described in this document only to the degree needed to cover new requirements and interactive graphics.

The Structures Branch has deleted the requirements to develop four of the functions in originally planned for Phase B: (1) Dynamic Loads, (2) Landing Flight Conditions, (3) Two-Body Separation Flight Conditions, and (4) Three-Body Separation Flight Conditions. The requirements for the remaining 25 functions plus the new requirements and interactive graphics requirements for the 4 Phase A functions are described in this document.

2.1 BACKGROUND

Present methods of structural analysis utilized by the Structures Branch require the successive application of stand-alone programs, each having unique input/output formats. Each program requires a high degree of user participation and interaction to select, interpret, and transfer data between programs and from various special purpose sources. The size and complexity of the Space Shuttle structural system makes this approach impractical for Space Shuttle analysis purposes. As an interim measure to

help relieve these problems, four high priority functions and a limited capability graphics system were developed as ISAS Phase A. Detailed requirements for the high priority functions were developed and presented in the *Detailed Requirements Document for Integrated Structural Analysis System (Phase A)*, Lockheed Electronics Company, Inc., LEC-0869. These requirements were reviewed by the Application Configuration Management Board and approved on December 10, 1973. This system was placed in operation in late 1974. The Phase B system described in this document will include the Phase A system and replace the interim graphics system.

2.2 GENERAL DESCRIPTION

In order to accomplish the required structural design and analysis for the Space Shuttle program, it is necessary to develop a system which will allow for automated static and dynamic analyses. ISAS will be a batch/remote/interactive system using remote graphical displays and several data bases. The data bases will contain aerodynamic and structural data in sufficient detail and quantity to allow prediction of Space Shuttle structural behavior under all expected operational conditions. The ISAS application programs will utilize this data to calculate trajectory and flight maneuver parameters as necessary to determine pressure and inertial forces, and subsequently, to compute structural responses to such forces.

ISAS will be installed on the UNIVAC 1110 and the Adage 330 graphics system. The development of the system will be a dual but integrated effort in the LEC contract. Category 1 support is presently developing application programs under management of the Structures Branch (ES2). Category 4 support will develop major data bases, storage procedures, maintenance and retrieval procedures, graphical display routines and procedures, and other programs deemed necessary to achieve the interactive

goals of ISAS. Category 4 support will also be responsible for the interfacing of the total system.

Wing and fuselage cross sections, time plots of aerodynamic loading, Mach number plots of aerodynamic forces, and vehicle deformation plots are examples of the type of graphical displays that will be made available at the Adage terminals. In addition, it is planned that the generation and maintenance of the temporary data bases of the system will be accomplished from the Adage terminal. Where appropriate, the system's analytical programs will be started through the use of a conversational remote job entry feature of the UNIVAC Exec 8 system.

The feasibility of ISAS's meeting functional requirements is demonstrated by the fact that major applications program components of the system are presently operational and are being utilized in a standalone, batch processing mode. Components yet to be developed that are vital to system operation are feasible based on past experience.

Figure 2.1-1 presents a low resolution diagram of the ISAS operating concepts. The system will be operated via the Adage 330 system, which is connected to the UNIVAC 1110 via a high speed line. When employing the system, the user will activate the ISAS Executive program. At this point, the user will be presented with a number of options, one of which he must select. The normal procedure would be for him to select an ISAS function, defined with conversational dialogue that will guide the user through the objectives of that function. The user may select to view data from the ISAS data base or to build additional files that will be merged or added to the data base. After the data manipulation functions have been completed, the user may wish to start an analytical program which will be run in the batch mode. In

ORIGINAL PAGE IS
OF POOR QUALITY

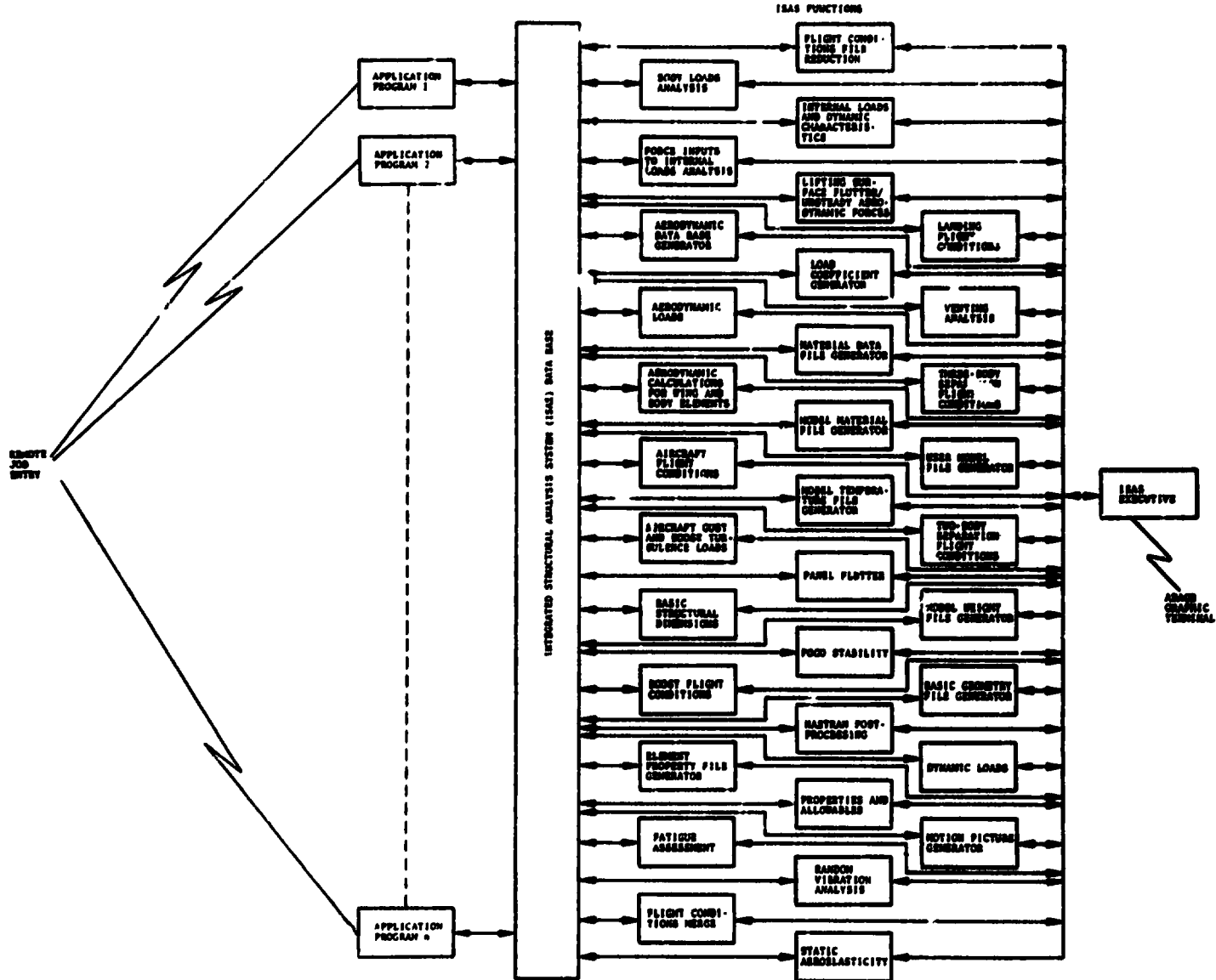

Figure 2.1-1. - Integrated Structural Analysis System operational concept.

order to start this batch program, the user will exercise the Remote Job Entry function of Exec 8. The user may check the status of the batch job by using another Exec 8 feature, FINDRUN. If the job has been run and print files exist, the user may interrogate these files by using the Exec 8 Editor, or he may use ISAS functions to review data contained in the data base.

All of the applications programs shown in Figure 2.1-1 will operate on the UNIVAC 1110 under the control of Exec 8 in the batch mode. Figure 2.1-1 does not imply where the ISAS functions will operate. A decision will be made during the development of the system design as to where the ISAS functions will run (UNIVAC 1110 or Adage DPR4). Part of the ISAS data base will reside on the Adage mass storage.

2.3 ASSUMPTIONS AND CONSTRAINTS

The detailed requirements for ISAS have been developed with the following assumptions.

- The development of ISAS will not require changes to the NASA Structural Analysis Program (NASTRAN), presently operational at the Lyndon B. Johnson Space Center (JSC). All NASTRAN input/output data will conform to the rigid input formats described in section 3 of the *NASTRAN User's Manual* (Level 15), NASA SP-222 (01), June 1972.
- The host computer will be the UNIVAC 1110 computer system or an equivalent configuration on which NASTRAN will operate and with which the Adage 330 graphics system can interface satisfactorily.
- There will be no language limitations for programs such as plot packages, interactive dialogue routines, etc.
- A maximum of seven and an average of three tape drives will be required for each analytical batch job in ISAS. These drives should also be available to programs run as remote

batch. There will be no tape requirements for the average interactive functions. However, some data management activities will require tape usage, but the frequency of these activities will be very low.

- All of the data requirements of ISAS could approach 60 to 75 million words of mass storage on the UNIVAC 1110. However, since both the ISAS development and the Space Shuttle analysis will be phased, it is presently reasonable to estimate that 22 million words of UNIVAC 1110 mass storage will be required at any one time.
- All data files and interactive programs must be designed in such a way that data can be retrieved and a display started at the terminal within 2 to 4 seconds on the average.

3. OPERATIONAL REQUIREMENTS

3.1 USER INTERFACE

The four basic requirements of the user interface for the ISAS are:

- The capability for the user to exercise control over the operation of the system.
- The capability to edit data obtained from any data file and to enter data into any defined file.
- The capability to display data (tabulations and graphics) for manual verification.
- The capability to start remote batch applications programs.

Due to the very large number of input/output files containing different types of data and the requirement for multifiles of the same type, the user must be able to specify the file to be used at any one time. At the same time, the user should be able to control what data is to be retrieved from or written onto the selected file.

Since ISAS will be comprised of numerous analysis functions, the user must be provided with a method by which he may activate an individual function. Due to various time restraints, it is not always reasonable to expect the user to process any of the ISAS functions from beginning to end. Therefore, it is required that the system be designed so that the user can stop the processing of a function and restart at that point at some later time. The system should provide a means by which it guides the user in selecting the position to start processing and to minimize the amount of manual input. The user must also be able to execute many ISAS functions in the batch mode.

It is required that the user have the ability to enter data directly to the system via the remote terminal. This data may be used to supplement data already in the system or may be used in place of reading a data file. Also, the user will want to delete data already in the system or replace some selected data items at times. Since the data used by different functions may be in many different formats, it is very important that the system guide the user concerning the format of the data that is to be entered.

The various tabulation and graphical displays required are described in the output sections of each ISAS function. At logical points throughout the processing, the system should indicate to the user what display options are available at that time. After a selection has been made, the user should have the ability to select the data to be displayed and to enter information such as plot ranges.

ISAS will also require that the following standard Exec 8 capabilities be provided to the user:

- To initiate a batch job that may require tape input from the remote terminal.
- To check the status of batch jobs to determine if they are backlogged, being processed, or completed.
- To create and/or delete mass storage data files.

A description of the above capabilities can be found in the *IDSD Procedures Manual*, part 20, entitled Exec 8 System.

The ability to control the operation of ISAS via the remote terminal is one of the basic requirements. The system must be designed in such a manner that the user need not be a data processing expert. Also, the system should not require the user to make constant reference to either an *ISAS User's Guide* or *Exec 8 Reference Manual*. Guidance should be provided to the user in

such a way that he is aware of the available options and what is expected of him. Figure 3.1-1 is an example of the dialogue between the user and ISAS.

3.2 HARDWARE/SOFTWARE CONFIGURATION

The host computer will be the UNIVAC 1110 computer system, operating under control of Exec 8. ISAS will require the following hardware to be available on the UNIVAC 1110:

- A maximum of seven and an average of three tape drives will be required for each analytical batch program. There will be no tape requirement for the normal interactive functions; however, some data management activities will require tape usage, but the frequency of these activities will be very low.
- All of the data required by ISAS could approach 60 to 75 million words of mass storage. However, since the ISAS development will be phased and the Space Shuttle analysis will also be phased, it is reasonable to estimate, at this time, that 22 million words of mass storage will be required. The remaining data should be maintained on tape and be available for loading into mass storage within 24 hours.
- The FR80 microfilm and hardcopy capability plus CALCOMP plots will be required in both the batch and remote batch mode of job entry. The ability of the FR80 to generate movies will be a special requirement of ISAS and is described in a later section.
- Access to at least one teletype compatible cathode-ray tube (CRT) terminal in Building 13 is required.

The requirements for high resolution, interactive graphics hardware are an integral part of ISAS. The graphics system (Adage 330) will interface the engineer with the analysis process in such a manner that a significant reduction in analysis time will be accomplished by an increase in the thoroughness of the analysis.

FORCE INPUTS TO INTERNAL LOADS ANALYSIS
INTERNAL LOADS SUBFUNCTION

ALL SCALE FACTORS HAVE BEEN INPUT

ARE TABULATIONS OF THE SCALE FACTORS TO BE DISPLAYED (REPLY YES
OR NO) _ _ _

IF NO

ANY OTHER RIGID BODY LOADS TO BE INCLUDED (REPLY YES OR NO) _ _ _

IF YES

ARE THE X,Y,Z TRANSLATION ACCELERATIONS TO BE INPUT VIA THE
TERMINAL (REPLY YES OR NO) _ _ _

IF NO

ENTER FILE NAME (MAX. OF 12 CHARACTERS) FOR FLIGHT CONDITIONS
FILE _ _ _ _ _

Figure 3.1-1. - Sample of dialogue between user
and machine.

To provide the interactive graphics capability required by ISAS, it will be necessary to have two graphics work stations in Building 13 that have the following features:

- Twenty-one-inch CRT
- Keyboard
- Function keys
- Light pen
- Trackball
- Hardcopy capability
- Character generator with rotation and multiple character sizes
- Data tablet
- Vector generator with multiple line types; i.e., solid, dashed, dotted, and variable line brightness
- Image characteristics, including three-dimensions, zoom, rotation, translation of specified parts of display, automatic scissoring, and 4096 × 4096 resolution

3.3 APPLICATIONS INTERFACE REQUIREMENTS

ISAS is required to interface with numerous batch analysis programs. This interface places three requirements on ISAS:

- Preparation and validation of input files for the analysis programs
- Acceptance of output files from the analysis programs
- Ability to start the analysis programs in the remote batch mode.

The batch analysis programs are:

- Transform Body Loads to Fine Grid
- Scale Rigid Body Loads (SCRIBL)

- System for Automatic Development of Static Aerothermodynamic Criteria (SADSAC) Reformat Program
- Aerodynamic Force Coefficient Program (FOCAP)
- Skin Friction Drag
- Analytic Pressure Distribution Program (ACE)
- Aircraft Maneuvers
- Lifting Surface Flutter
- Gust Response
- Turbulence Response
- Boost Flight
- NASA Structural Analysis (NASTRAN)
- Automated Structural Optimization (ASOP)
- Analysis of Aerospace Structures by the Displacement Method (Air Force Program)
- Panel Flutter Program
- POGO Stability
- Report Program
- Grid Point Resequencing Program
- Accumulative Damage Fatigue Program
- Equivalent Damage Spectra Fatigue Program
- Loads Coefficient Generator
- Dynamic Modal Response Program (FRISBE)
- NASTRAN to FRISBE data conversion (NASTOF)
- North American Rockwell Deblock Program (NRDBOK)
- SAMIS (Structural Analysis and Matrix Interpretive Program) to FRISBE data conversion (SATOF)
- Aerodynamic Noise Model

- Random Response
- Static Aeroelasticity
- Venting Analysis Digital Computer Program (VADIC)
- Acoustic Noise Model Program
- Adjust Steady-State Aerodynamic for Unsteady Effects and Calculate Generalized Forces

The preceding list does not contain all the programs that will interface with ISAS at any one time. Any program that conforms to the formats of ISAS data files will be allowed to interface with ISAS.

4. ISAS FUNCTION REQUIREMENTS

4.1 AERODYNAMIC AND INERTIAL LOADS

This function of ISAS was separated into two subsystems (Force Inputs to Internal Loads Analysis and Body Loads Analysis) during Phase A development. The detailed requirements for each subsystem can be found in the *Detailed Requirements Document for Integrated Structural Analysis System (Phase A)*, LEC-0860. Since that development, additional requirements have been created for each subsystem and are described in the following sections. Only the new requirements and graphical output are discussed. Figure 4.1-1 is a data flow diagram showing the two subsystems for Aerodynamic and Inertial Loads.

4.1.1 FORCE INPUTS TO INTERNAL LOADS ANALYSIS

4.1.1.1 Purpose

This subsystem is needed in order to prepare a file of NASTRAN bulk data card images containing aerodynamic and/or inertial loads. Once the file is complete, it will be input to NASTRAN for analysis. It is required that this subsystem be designed primarily to operate in the demand mode and provide the remote terminal user with the ability to include loads data, to have data displayed for his analysis, and to perform data modifications and additions. Figure 4.1-1 shows the data flow for the Force Inputs to Internal Loads Analysis subsystem.

4.1.1.2 Input

The input data required by this subsystem can be obtained from any combination of the following eight data files.

- SCRIBL Output File
- ISAS Flight Conditions File
- Merged Flight Conditions File

- User Model File
- Model Weight File
- C_p at Required Points File
- VADIC Output File
- Force Coefficient Data File

Detailed descriptions of these files can be found in the appendix of this document. In place of any data file, the user may select to enter data directly at the remote terminal.

4.1.1.3 Processing

In the Phase A system, the following information is retrieved from the ISAS Flight Conditions File.

- Rigid body X, Y, and Z translational accelerations
- X, Y, and Z axes rotational accelerations
- Flexible body generalized coordinate accelerations

These data are used to construct images of NASTRAN bulk data cards.

A requirement of the Phase B system is that the subsystem must have the capability to retrieve these data from either an ISAS Flight Conditions File or a Merged Flight Conditions File. If the user elects to use the ISAS Flight Conditions File, the program should function as it is now coded and described in the Phase A detailed requirements document. If the Merged Flight Conditions File is to be used, a new retrieval method is required. Before any data are retrieved from the merged file, the user should be allowed to have the time and a two-word identification block from each data block displayed. When selecting data from the merged file, the user must use the two-word identification block in place of time because time may not be unique on the merged file. Once the data have been selected, the processing will be

the same as is now coded and described in the Phase A detailed requirements document for data from the ISAS Flight Conditions File.

4.1.1.4 Output

The primary output of this subsystem is the Model Loads File, which contains card images of NASTRAN bulk data cards. In preparing these card images, the user requires the ability to have both input and output data (tabulations) displayed at the remote terminal. The display of the card images should be a straight listing with no special headings.

If differential pressure (ΔP) is to be calculated, four different types of plots may be requested. The machine should calculate the maximum and minimum values for the plots. The first plot is the ΔP versus Mach number for the selected station.

For this plot, the user must specify the X, Y, and Z coordinates of the station. An example of this display is shown in figure 4.1-2.

Figure 4.1-3 shows an example of the second type of plot for a fuselage. For this plot, the user must specify the time and angular position, ϕ , for the fuselage, (percent chord Y for wing, percent span Z for tail). A plot of the vehicle at the given ϕ is shown at the bottom of the plot.

For the third type of plot, the vehicle cross section at a given X station will be plotted, about which the differential pressure at all values of ϕ will be plotted. Also, a reference guide for ΔP equals 0 should be plotted around the cross section. The user must supply the time and X station (Y for wing, Z for tail) before the plot can be created. Figure 4.1-4 shows an example of this display.

The last plot type should contain ΔP versus time for a given location (X, Y, and Z coordinates) on the vehicle. Figure 4.1-5 shows an example of this type of plot.

4.1.2 BODY LOADS ANALYSIS

4.1.2.1 Purpose

This subsystem is required in order to calculate body loads for different stations on the vehicle for various flight conditions. It should be designed to operate primarily in the demand mode and provide the user, at the remote terminal, the ability to interactively (1) select the type and quantity of input data to be included, (2) display the data and computational results for his analysis at various key places in the program, (3) perform data modifications and additions, and (4) select the format for the tabulation and graphical outputs at the remote terminal.

This subsystem is also needed to create a Load Input Data File. This file will contain body loads data which are needed for NASTRAN processing and analysis. A batch transformation program will use the data from this file to create a NASTRAN Input Loads File which will be input to NASTRAN. Figure 4.1-1 shows the data flow for the Body Loads Analysis subsystem.

4.1.2.2 Input

The input data required by this subsystem will be obtained from the three data files listed below.

- ISAS Flight Conditions File
- Force Coefficient Data File
- Load Coefficient Data File

Detailed descriptions of these files can be found in the appendix of this document. The user will have the capability to supplement



or modify any of the data obtained from the above files by the use of the remote terminal.

The user will also input by cards or at the remote terminal any information needed by this subsystem to produce the desired output from the data obtained from the above files. This information will include:

- The load stations at which loads are to be calculated
- The times at which loads are to be calculated
- The dynamic factors to be used
- The format ID for tabulations and graphical displays output

4.1.2.3 Processing

The Phase A detailed requirements document describes the four subfunctions which make up the Body Loads Analysis subsystem. This document describes the requirements for a fifth subfunction, Order Body Loads.

Order Body Loads will take many Body Loads Data Files, determine the maximum and minimum loads for each load station from each file, and then order these maximum and minimum loads for display. The maximum and minimum loads will be output on a Maximum Loads Data File.

Four separate cases should be considered in this subsystem.

1. No previous Maximum Loads Data File exists, and the file must be generated from scratch.
2. An old Maximum Loads Data File exists, and the file must be updated using new Body Loads Data Files as input.
3. The data contained on a Maximum Loads Data File will be ordered.
4. The data contained on the Maximum Loads Data File will be displayed.

For case 1, a Body Loads Data File will be input. The start and stop times will be displayed, and the user will enter the start and stop times to be used in retrieving data. The load stations will also be displayed for the user to select those stations to be used in retrieving data. Using the time range input, the file will be searched, and the maximum and minimum values for each total load component (i.e., shear X, shear Y, shear Z, moment X, moment Y, moment Z), root summed square (RSS) force, and RSS moment will be located for each load station selected by the user. After each of these maximum and minimum values are located, the time that the maximum or minimum load occurred and the other eight loads (three shears, three moments, RSS shear, RSS moment) will be output onto the Maximum Loads Data File. These data values will be output for each load component in the following order.

- Maximum shear X
- Minimum shear X
- Maximum shear Y
- Minimum shear Y
- Maximum shear Z
- Minimum shear Z
- Maximum moment X
- Minimum moment X
- Maximum moment Y
- Minimum moment Y
- Maximum moment Z
- Minimum moment Z
- Maximum RSS shear
- Minimum RSS shear

- Maximum RSS moment
- Minimum RSS moment

For case 2, a Maximum Loads Data File which has already been created will be updated using one or more Body Loads Data Files. The following comparisons will be performed on the identification (ID) blocks of the Maximum Loads Data File and the Body Loads Data File.

- The first two words of the 24-word title block will be checked for a match.
- All of the load stations contained on the Maximum Loads Data File must exist on the Body Loads Data File.
- The start and stop times on the Maximum Loads Data File must be within the start and stop times of the Body Loads Data File.

If any of these comparisons fail, a detailed message describing the problem will be output, and the program will request a new Body Loads Data File. After a valid Body Loads Data File is input, the maximum and minimum loads for this file will be located as described in case 1. These maximum and minimum loads will be output onto the next file of the Maximum Loads Data File. This procedure is repeated until all Body Loads Data Files have been input. At this time, case 3 (ordering the loads) will be activated. Ordering the loads will consist of searching the entire Maximum Loads Data File and ordering each load component for each load station. These ordered values will be displayed for the case 4 option.

Four display format options will exist.

1. One load component only
2. Load matrix

3. File numbers and partial titles list
4. Full titles for the file numbers input

For display options 1 and 2, the user will select the load stations he wishes to have displayed. For display option 1, the user will select the number of ordered values (NUMB) to be displayed and one of the following options:

- a. Both maximum and minimum ordered values
- b. Only maximum ordered values
- c. Only minimum ordered values
- d. Ordered absolute values

The format for display option 1a is shown in figure 4.1-6. The format for display options 1b, 1c, and 1d is shown in figure 4.1-7. The format for display option 2 is shown in figure 4.1-8. Display option 3 should consist of a list of the file numbers and as much of the individual titles as can possibly fit onto one line. The first two words of the title should not be output as they will be the same for all files. Display option 4 should consist of the user inputting a sequence of file numbers and the program outputting a list of the file numbers and the full title for each file number.

4.1.2.4 Output

The Body Loads Analysis function is comprised of five subfunctions. Each of these subfunctions will output a data file. These output files are:

- Compressed Aerodynamic Forces and Conditions File
- Load Input Data File
- Body Loads File
- Modified Body Loads File
- Maximum Loads Data File

Detailed descriptions of these files can be found in the appendix of this document. The Load Input Data File is the only file which will be used by another ISAS function. The batch Body Loads Transformation Program will use this file as input and create a NASTRAN Input Loads File. NASTRAN will use this input file in the processing of body loads data. The transformation program will operate in the batch mode and is not discussed in this document.

The tabulation displays required for data from the first four files listed are described in the Phase A detailed requirements document. The tabulation displays required for the data from the Maximum Loads Data File are described in the preceding section, and examples of these displays are given in figures 4.1-6, 4.1-7, and 4.1-8.

Graphical displays will be required for the data contained on the Body Loads File, Modified Body Loads File, and Maximum Loads Data File. All graphical displays should be generated for a specific component of the vehicle such as Orbiter fuselage or Orbiter right wing.

Data contained on the Body Loads File or the Modified Body Loads File should be displayed as described in the following paragraphs.

1. Display 1 will be a plot of load versus station for a given time. The ordinate should be the total shear X, Y, or Z; the total moment X, Y, or Z; the RSS shear; or the RSS moment. The abscissa should be the X, Y, or Z station. For example, the X station would consist of all load stations with given Y and Z coordinates.
2. Display 2 will be the same as 1 except the ordinate will be the difference in total loads between two stations.
3. Display 3 will be the same as 1 except multiple loads may be plotted on the ordinate. The ordinate may be any or all of the component loads as well as the total loads.

4. Display 4 will be a plot of load versus time for a given load station. The ordinate should be the total shear X, Y, or Z; the total moment X, Y, or Z; the RSS shear; or the RSS moment. The abscissa will be the time bounded by the user selected start and stop time.
5. Display 5 will be a plot of maximum loads between given start and stop times versus station. The ordinate will be the maximum total shear X, Y, or Z; the total moment X, Y, or Z; the RSS shear; or the RSS moment. The abscissa should be the X, Y, or Z station.
6. Display 6 will be the same as display 5 except it will be a plot of the minimum loads.
7. Display 7 will be the same as display 1 with the following exceptions. A maximum of five plots may be drawn on one display. The data for these plots may be taken from any combination of five Body Loads Files.
8. Display 8 will be the same as display 4 except a maximum of five plots may be plotted on one display. Each plot will be from a different Body Loads File. The user will also select the start and stop times for this display.
9. Display 9 will be a plot of component load versus time for a given load station. The ordinate should be the component shear X, Y, or Z or the component moment X, Y, or Z.

There will be two displays for data from the Maximum Loads Data File. These displays will be the same as displays 5 and 6.

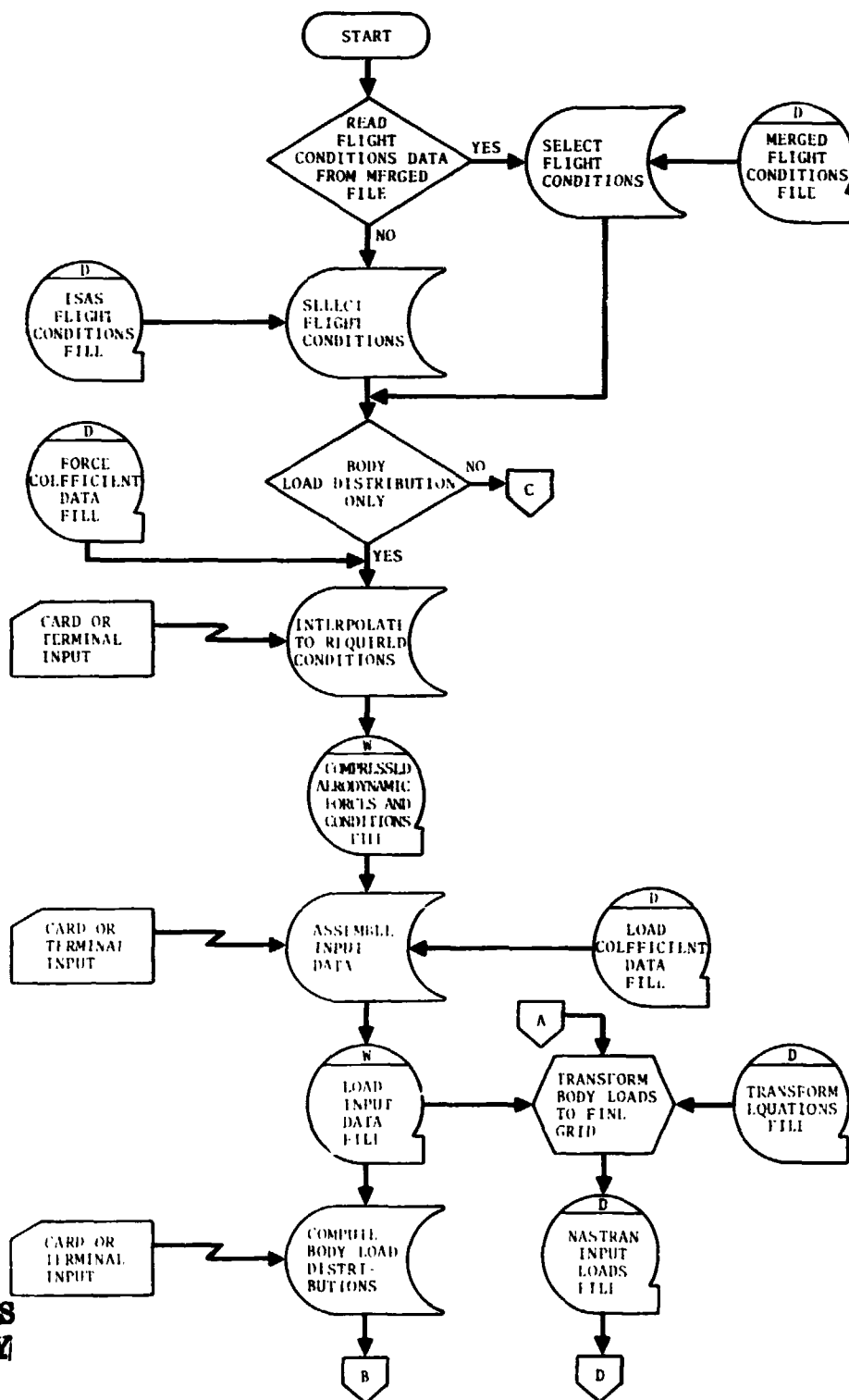

ORIGINAL PAGE IS
OF POOR QUALITY

Figure 4.1-1. -- Data flow diagram of Aerodynamic and Inertial Loads function.

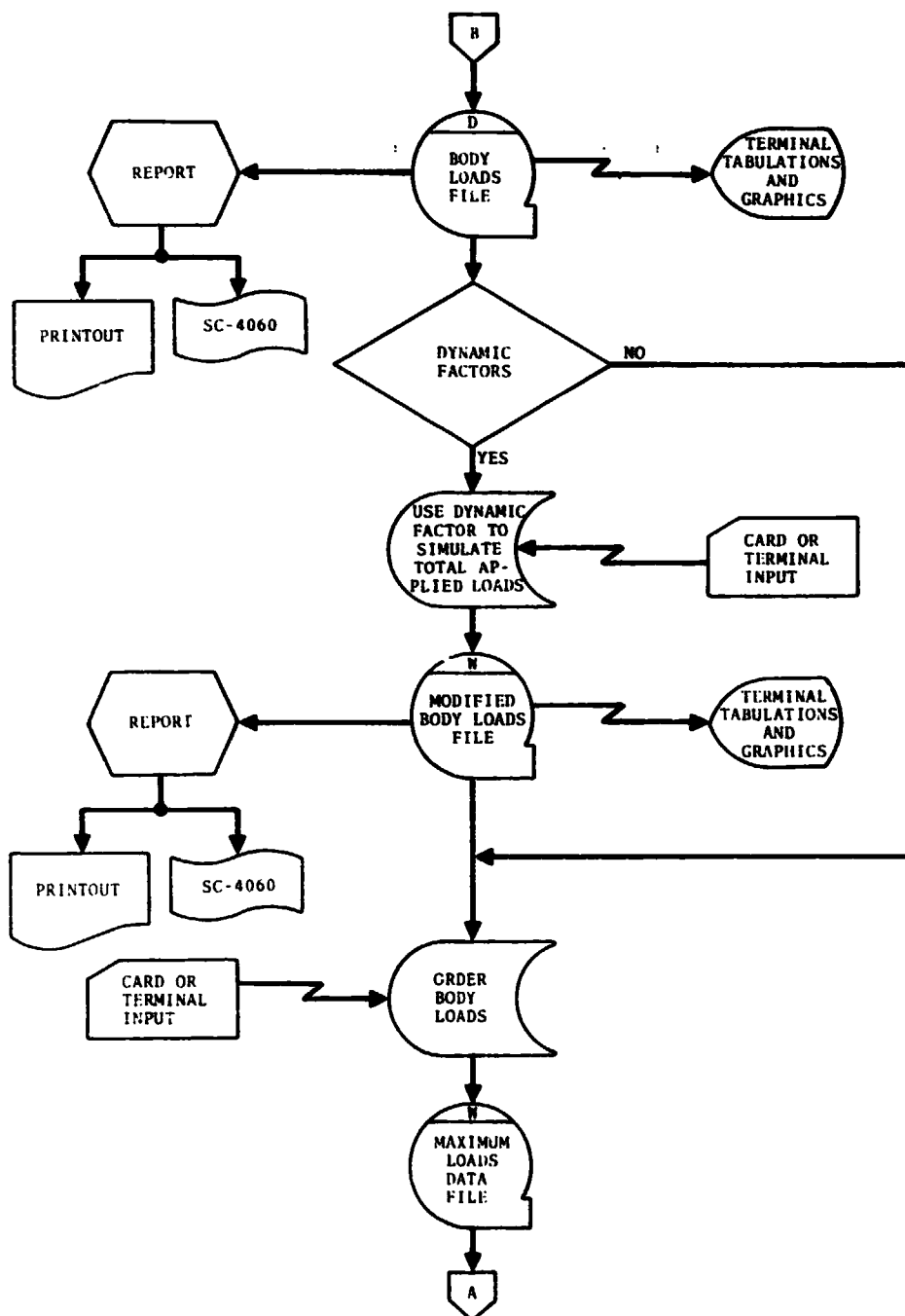
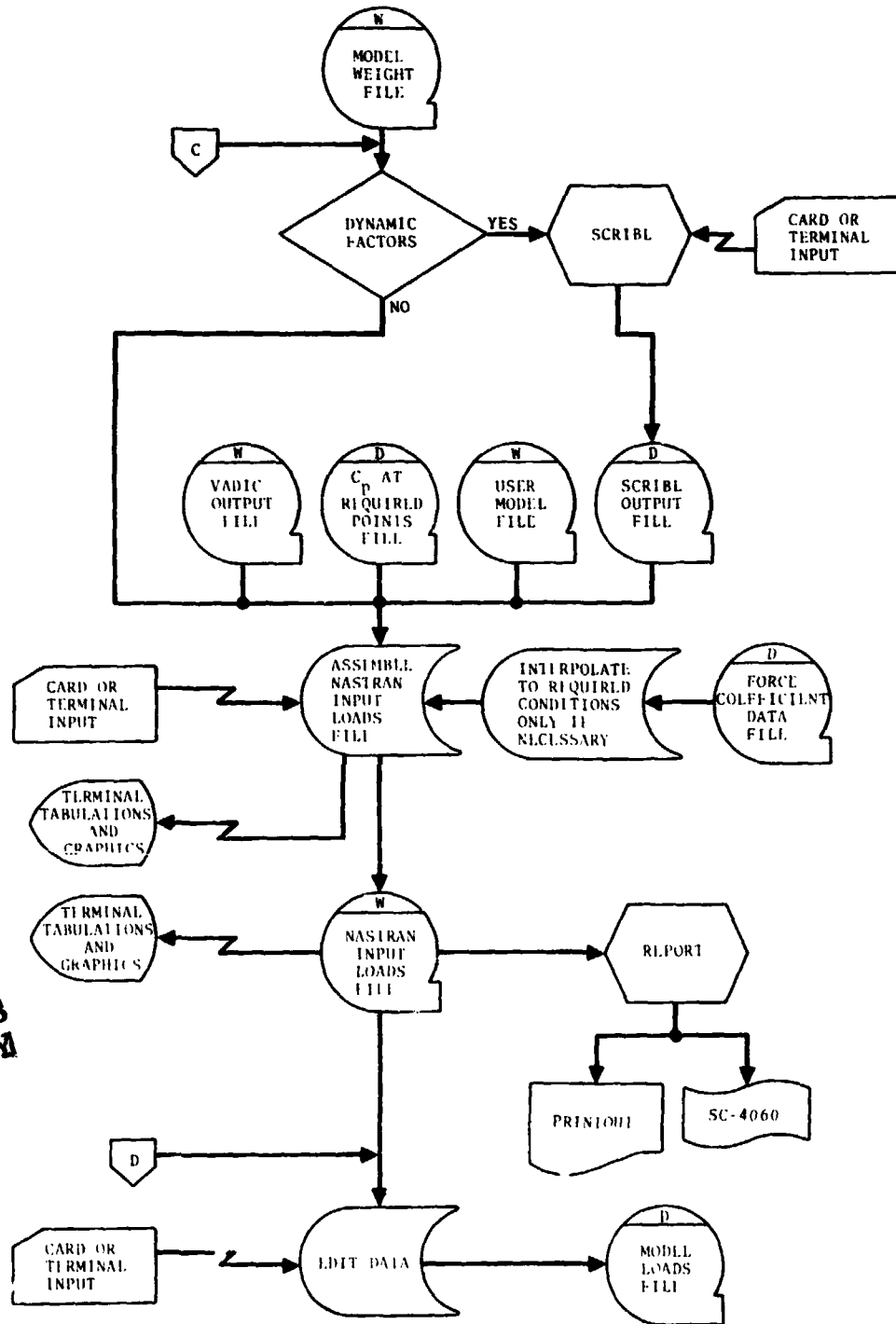

Figure 4.1-1. - Data flow diagram of Aerodynamic and Inertial Loads function (continued).



ORIGINAL PAGE IS
OF POOR QUALITY

Figure 4.1-1. - Data flow diagram of Aerodynamic and Inertial Loads function (concluded).

TITLE

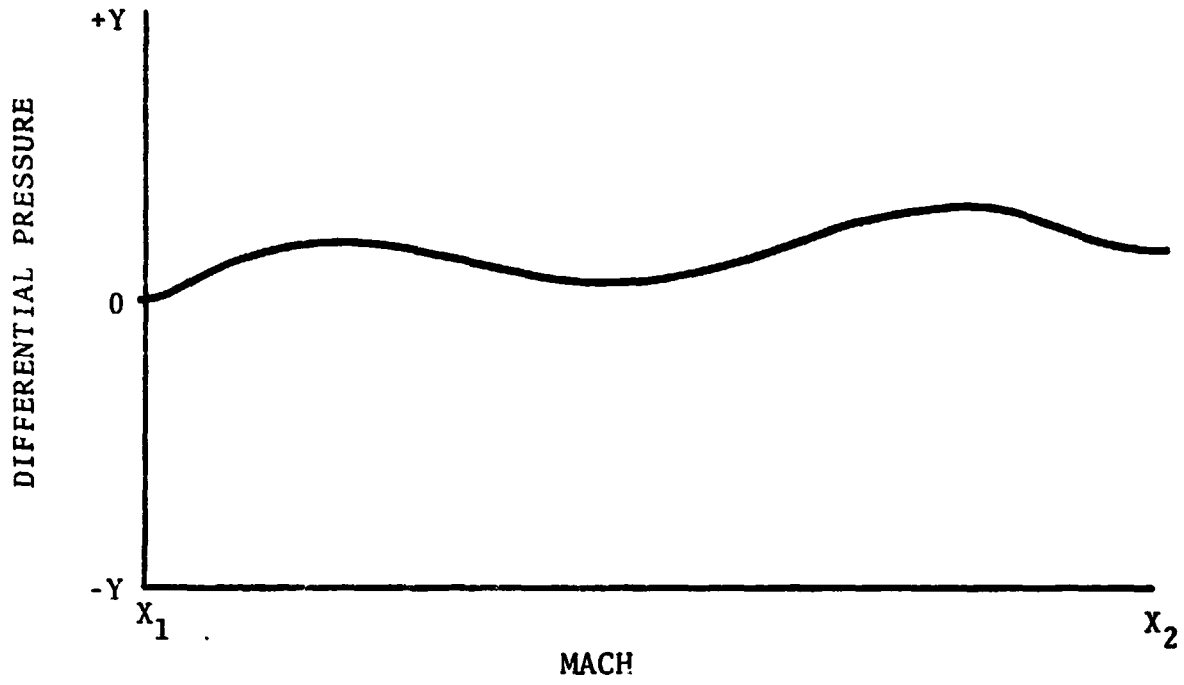

X = _____ Y = _____ Z = _____

Figure 4.1-2. - Differential pressure versus Mach number.

TITLE

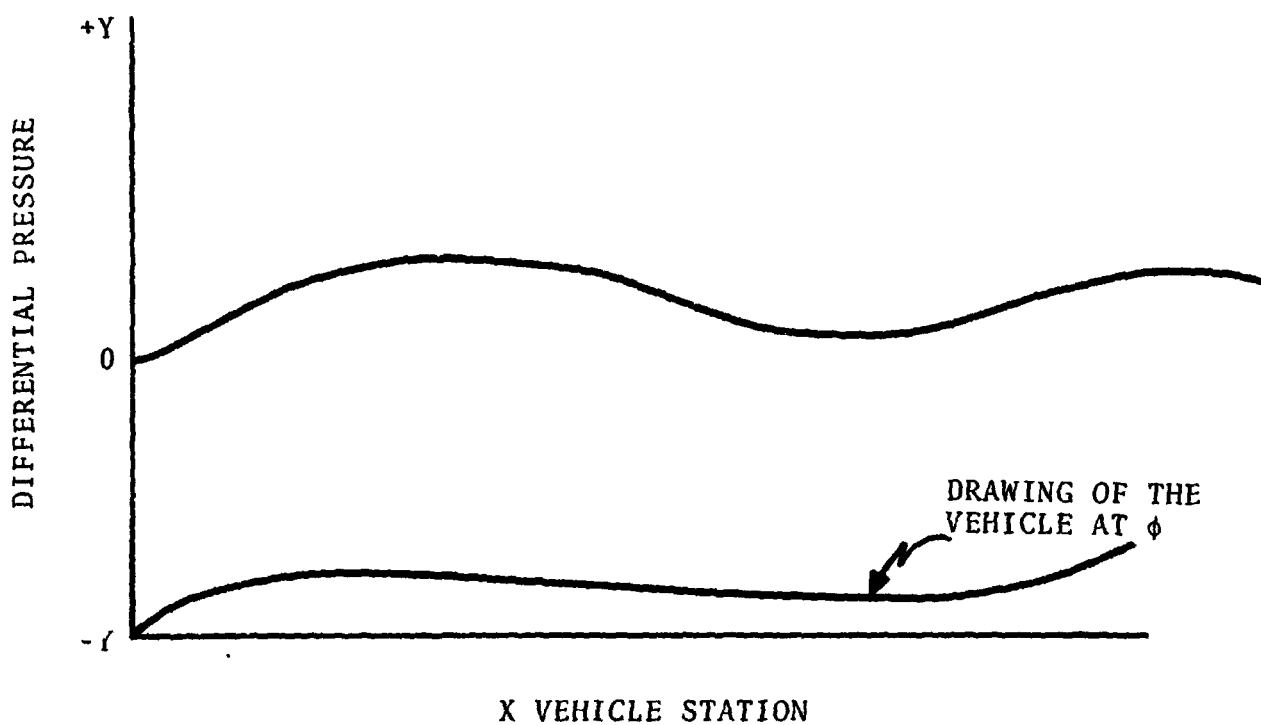

TIME = _____
MACH = _____
BETA = _____
DELTA E = _____

ALPHA = _____
DELTA R = _____
PHI = _____

Figure 4.1-3. ~ Differential pressure versus X vehicle station.

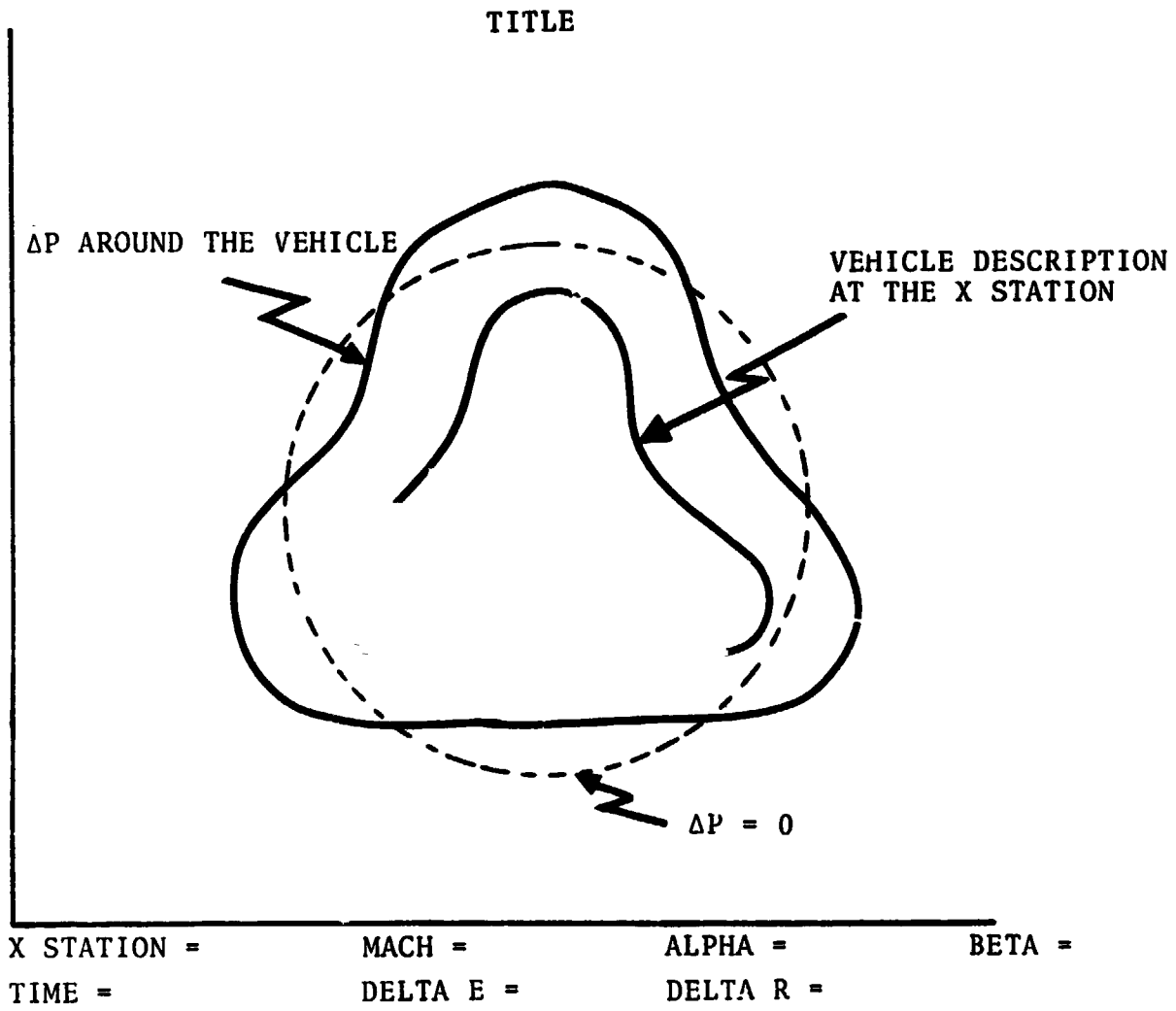
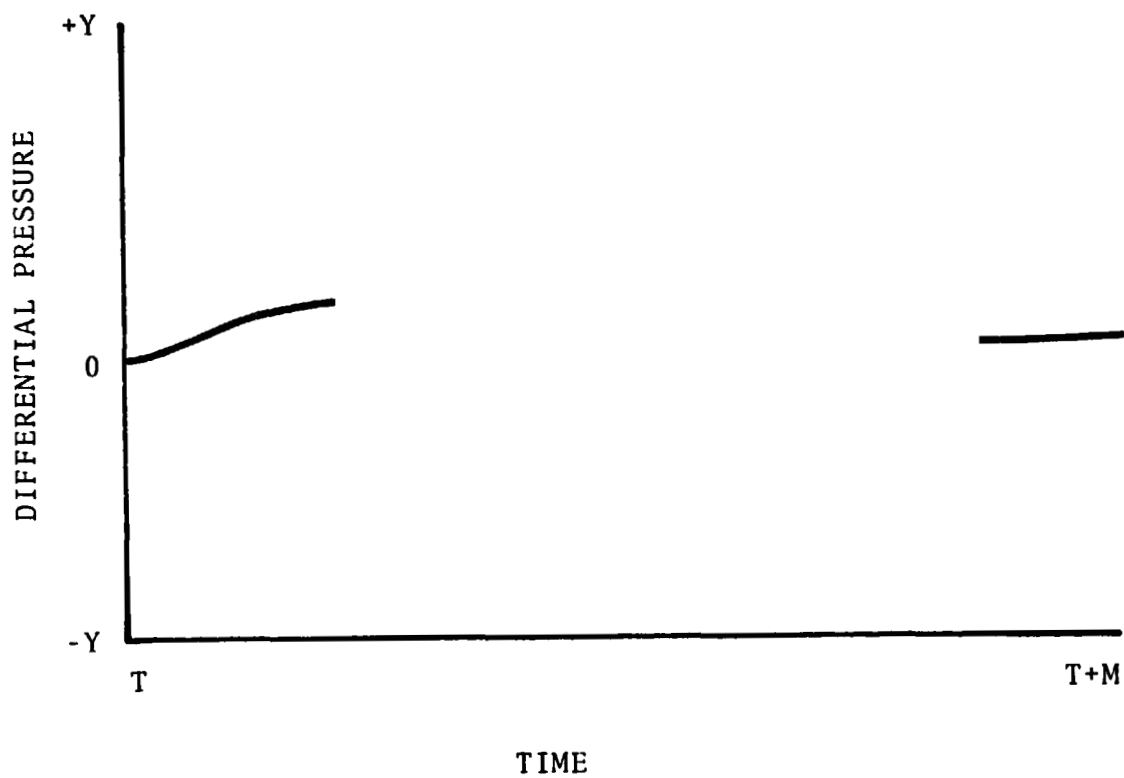

Figure 4.1-4. - Vehicle cross section at a given X station.

TITLE



X STATION = _____ Y = _____ Z = _____

Figure 4.1-5. - Differential pressure versus time.

ORDERED LOADS FOR SHEAR X
 VEHICLE COMPONENT: ORBITER FUSELAGE
 LOAD STATION: X = 1365.0 Y = -150.7 Z = 480.5

NUMBER	MAXIMUM VALUES			MINIMUM VALUES		
	FILE NUMBER	TIME	LOAD VALUE	FILE NUMBER	TIME	LOAD VALUE
1	6	109.5	758109.5	20	10.2	-109542.9
2	20	2.3	746925.4	15	80.1	-98765.8
3	15	10.6	730799.1	30	40.3	-87654.3
.
.
.
NUMB	140	1055.6	545454.4	120	80.4	5004.3

Figure 4.1-6. - Display for both maximum and minimum ordered loads.

ORDERED LOADS FOR ABSOLUTE SHEAR Z
VEHICLE COMPONENT: RIGHT WING
LOAD STATION: X = 1390.3 Y = 179.5 Z = 200.9

NUMBER	FILE NUMBER	TIME	LOAD VALUE
1	7	1.0	758942.6
2	18	100.5	-747653.4
3	103	50.4	723218.6
.	.	.	.
.	.	.	.
.	.	.	.
NUMB	29	986.5	-543214.4

Figure 4.1-7. - Display for one set of ordered loads.

VEHICLE COMPONENT: ORBITER FUSELAGE
 LOAD STATION: X = ___ Y = ___ Z = ___

LOAD CONDITION	FILE NUMBER	TIME SEC	AXIAL K-LB	SHEAR Y K-LB	SHEAR Z K-LB	MOM X MIL. IN-LB	MOM Y MIL. IN-LB	MOM Z MIL. IN-LB	RSS SHEAR K-LB	RSS MOM MIL. IN-LB
MAX SHEAR X										
MIN SHEAR X										
MAX SHEAR Y										
MIN SHEAR Y										
MAX SHEAR Z										
MIN SHEAR Z										
MAX MOMENT X										
MIN MOMENT X										
MAX MOMENT Y										
MIN MOMENT Y										
MAX MOMENT Z										
MIN MOMENT Z										
MAX RSS SHEAR										
MIN RSS SHEAR										
MAX RSS MOMENT										
MIN RSS MOMENT										

ORIGINAL PAGE IS
 OF POOR QUALITY

4-20

Figure 4.1-8. - Loads matrix output format.

4.2 AERODYNAMIC DATA BASE GENERATOR

The original requirements for this function were described in the *Detailed Requirements Document for Integrated Structural Analysis System (Phase A)*, LEC-0860. The Phase A system included the capability to satisfy all of the requirements except for graphical output. Since the development of Phase A, additional requirements have been identified and are described in the following sections. Only the new requirements and graphical output are discussed in this document.

4.2.1 PURPOSE

This function will generate and maintain data files containing pressure coefficients to be used by other ISAS functions and batch analysis programs. This function will also create tabular and graphical displays of data at the remote terminal to be used by the engineer for data validation. Figure 4.2-1 is a data flow diagram of the function.

4.2.2 INPUT

Data for the Aerodynamic Data Base Generator function may be obtained from any combination of the following sources:

- Interim SADSAC Data File
- User Model File
- Aerodynamic Data File
- Aerodynamic Influence Coefficients File
- ACE Output Data File
- Manual input through the remote terminal

Detailed descriptions of the data files are contained in the appendix of this document.

4.2.3 PROCESSING

In the Phase A system, the pressure coefficients were identified and retrieved by Mach number (M), angle of attack (α), angle of sideslip (β), elevon deflection (Δe), and rudder deflection (Δr). New configurations of the Space Shuttle have shown that additional retrieval parameters are required and that different parameters are needed for different configurations. It is now required that each Aerodynamic Data Base allow for a minimum of 3 and a maximum of 15 retrieval parameters. The first three retrieval parameters will be Mach number (M), angle of attack (α), and angle of sideslip (β) on each data file. The remaining retrieval parameters will be variable for each file. All of the sets of data on a file will have the same retrieval parameters.

All other requirements described in the Phase A detailed requirements document will apply to the Phase B system.

4.2.4 OUTPUT

The primary output from this function will be the Aerodynamic Data Base. However, the C_p at Required Points File can be used as input to other ISAS functions and batch programs and is therefore considered an output file.

The user requires the capability to have tabular and/or graphical displays created using data from the following files:

- Interim SADSAC Data File
- C_p at Required Points File
- User Model File
- Aerodynamic Data File
- Aerodynamic Data Base
- ACE Output Data File

From the User Model File, the displays will consist of graphical displays of geometric data, which will describe the model. The user will have the capability to modify the data on this file in the User Model File Generator.

Figure 4.2-2 is an example of the tabular display of pressure coefficient (C_p) data. This data display will be created from any file containing this type of data. The program should provide the capability to modify (change only) any of the data displayed.

The graphical display should be as general as possible and contain the same identification data as the tabulations. The ability to plot the following measurements should exist:

- C_p versus selected X, Y, or Z coordinate
- C_p versus selected retrieval parameter and value

Figure 4.2-3 is an example of this plot type.

The capability to display in tabular form the force and moment totals is also required. The values for the measured totals will be retrieved from the C_p at Required Points File, and the calculated values will be retrieved from the Aerodynamic Data File. Figure 4.2-4 is an example of this type of display.

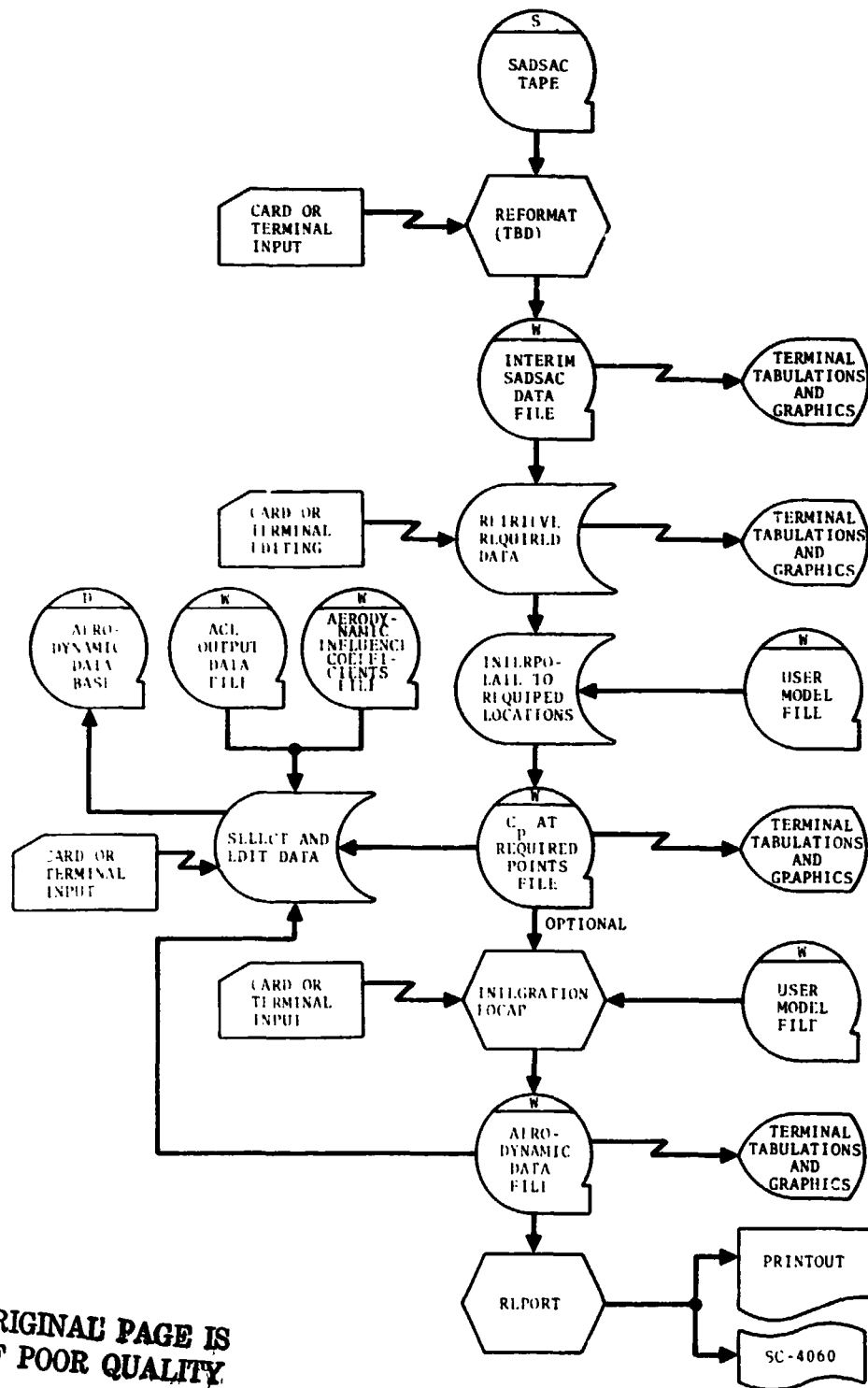

ORIGINAL PAGE IS
OF POOR QUALITY

Figure 4.2-1. -- Data flow diagram for Aerodynamic Data Base Generator.

NAAL 699 DATASET MERGE FOR JSC
 P10C5D7M2F1W87E18VSRSG1 LEFT FUSELAGE

REFERENCE DATA		PARAMETER DATA			
SREF =	4.4120 SQ.FT.	XMRP =	35.4974 INCHES	ELEVTR =	.000
LREF =	19.3000 INCHES	YMRP =	.0000 INCHES	RUDDER =	.000
BREF =	37.9350 INCHES	ZMRP =	16.2000 INCHES	RUDFLR =	40.000
SCALE =	.0405 SCALE			FLAP =	-18.000

SECTION (1) LEFT FUSELAGE BETA(8) = 10.020 ALPHA(9) = 10.140

X/L	DEPENDENT VARIABLE CP				
	.0000	.0075	.0188	.0339	.0602
PHI					
.0000	.6931	.6174	.2177	.0891	99.9900
20.0000			.1517	-.4741	.2042
40.0000			.0616	-.3428	-.0861
55.0000			-.0940	-.3389	-.2355
70.0000			-.3533	-.4362	-.2912
90.0000		.0941	-.2839	-.4185	-.1573
120.0000			-.3239	-.3345	-.1406
142.0000					
150.0000			-.3193	-.2696	-.1501
157.0000					
162.0000					
169.0000					
172.0000					
180.0000		.0800	-.3109	-.2033	-.1102

Figure 4.2-2. - Tabulation of SADSAC data.

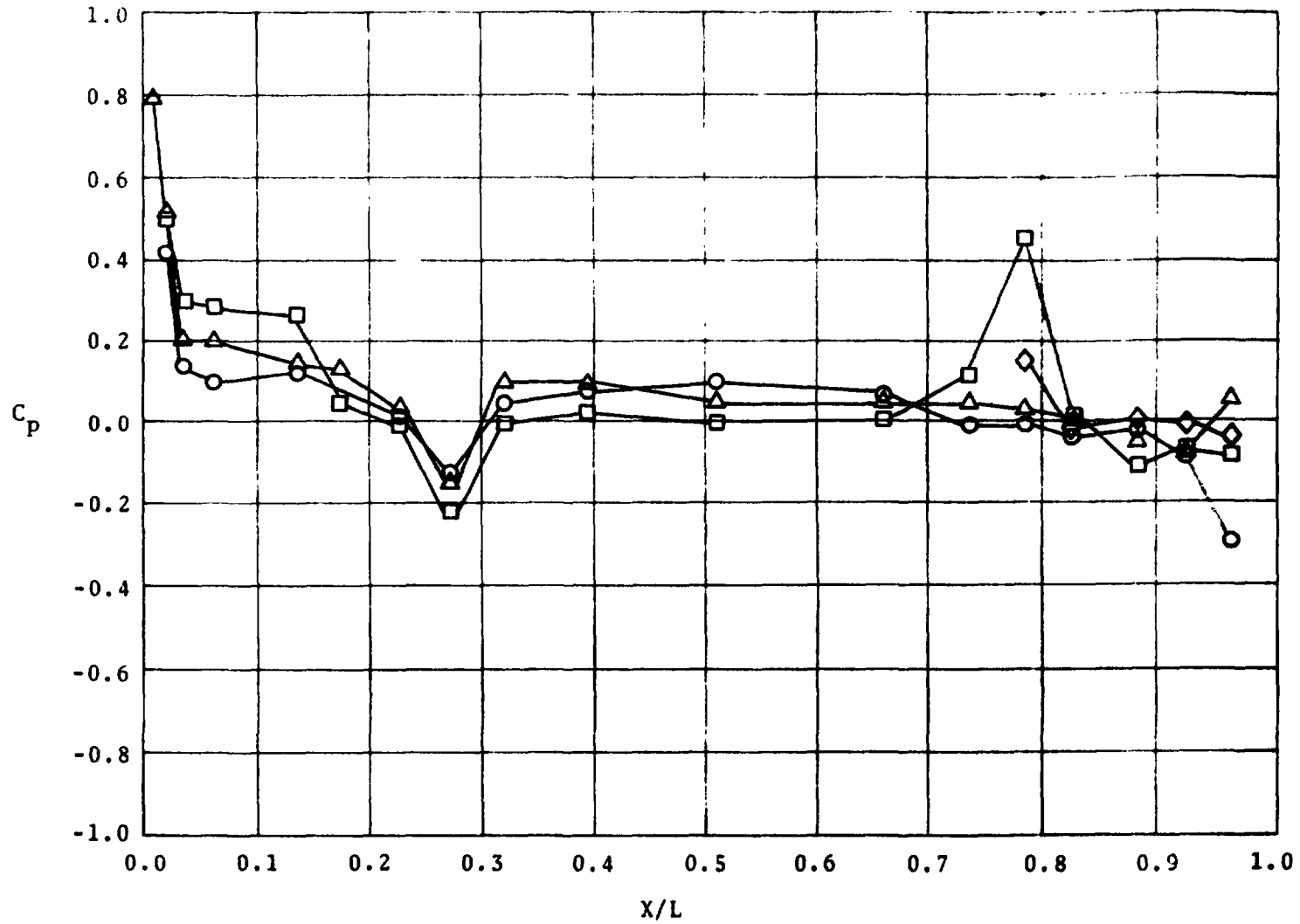

Figure 4.2-3. - Longitudinal pressure distribution of the fuselage, neutral rudder, and elevator.

\square = $\phi = 35^\circ$
 \triangle = $\phi = 45^\circ$
 \circ = $\phi = 55^\circ$

	MEASURED TOTALS (F12.5)	CALCULATED TOTALS (F12.5)	PERCENT ERROR (F6.1)
F _X			
F _Y			
F _Z	.	.	.
M _X	.	.	.
M _Y	.	.	.
M _Z			
	RETRIEVAL PARAMETER IDENTIFICATION		VALUE
	1		(F8.2)
	.		.
	.		.
	.		.
	15		

Figure 4.2-4. - Example of tabular display of force and moment totals.

4.3 AERODYNAMIC LOADS

The *Detailed Requirements Document for the Integrated Structural Analysis System (Phase A)*, LEC-0860, contained the original requirements for this function. The Phase A system, as developed, included the capability to satisfy those requirements except for graphical displays. Since the development of the Phase A system, additional requirements have been identified and are described in the following sections. Only the new requirements and graphical output requirements are discussed in this document.

4.3.1 PURPOSE

This function will create a data file containing force coefficients; the file will be used in other ISAS functions and batch analysis programs. This function will consist of three distinct operations. The first will be under control of the demand program and will serve the purpose of creating a C_p at Required Points File. The demand program will then release control to two batch analysis programs, FOCAP and Skin Friction Drag, which will use the C_p at Required Points File and the User Model File as input and will output force coefficient data and skin friction data, respectively. These files will then be used by the second demand subfunction to form a Force Coefficient Data File.

This document is concerned with only the demand processing; however, all input/output files are described in the appendix. Figure 4.3-1 is a data flow diagram of the Aerodynamic Loads function.

4.3.2 INPUT

The following files will be used as input.

- Aerodynamic Data Base
- User Model File

- Skin Friction Data File
- Force Coefficient Data File

Each of these files is described in the appendix of this document.

Additional input will be supplied using cards or the remote terminal. Control over the operation of this function will be exercised through the remote terminal or card input; the user will specify the data to be retrieved, interpolated, integrated, and edited.

4.3.3 PROCESSING

In the Phase A system, the pressure coefficients (C_p) contained on the Aerodynamic Data Base were identified and retrieved by Mach number (M), angle of attack (α), angle of sideslip (β), elevon deflection (Δe), and rudder deflection (Δr). The force coefficient data was also identified and retrieved using the same parameters. New configurations of the Space Shuttle have shown that additional retrieval parameters are required and that different parameters are needed for different configurations. Each data set will be identified by a minimum of 3 and a maximum of 15 retrieval parameters. The first three retrieval parameters will always be Mach number (M), angle of attack (α), and angle of sideslip (β). The remaining retrieval parameters will be variable for each file, but all data sets on a file must have the same parameters.

In many cases the required data will not be contained in the Aerodynamic Data Base. In these cases, the program will be required to perform linear interpolation to obtain data for the selected values of the retrieval parameters. A detailed description of the linear interpolation requirements is contained in the detailed requirements document for Phase A. This interpolation routine will interpolate on a minimum of three and a maximum of

six retrieval parameters. The first three will always be Mach number, angle of attack, and angle of sideslip. The user may select any other retrieval parameter for interpolation as required.

4.3.1 OUTPUT

The following files are output by this function:

- C_p at Required Points File
- Force Coefficient Data File

This function will have the capability of displaying tabulations and graphics of data from all input and output files. The remote terminal displays required by this function are identical to the displays of the Aerodynamic Data Base Generator function.

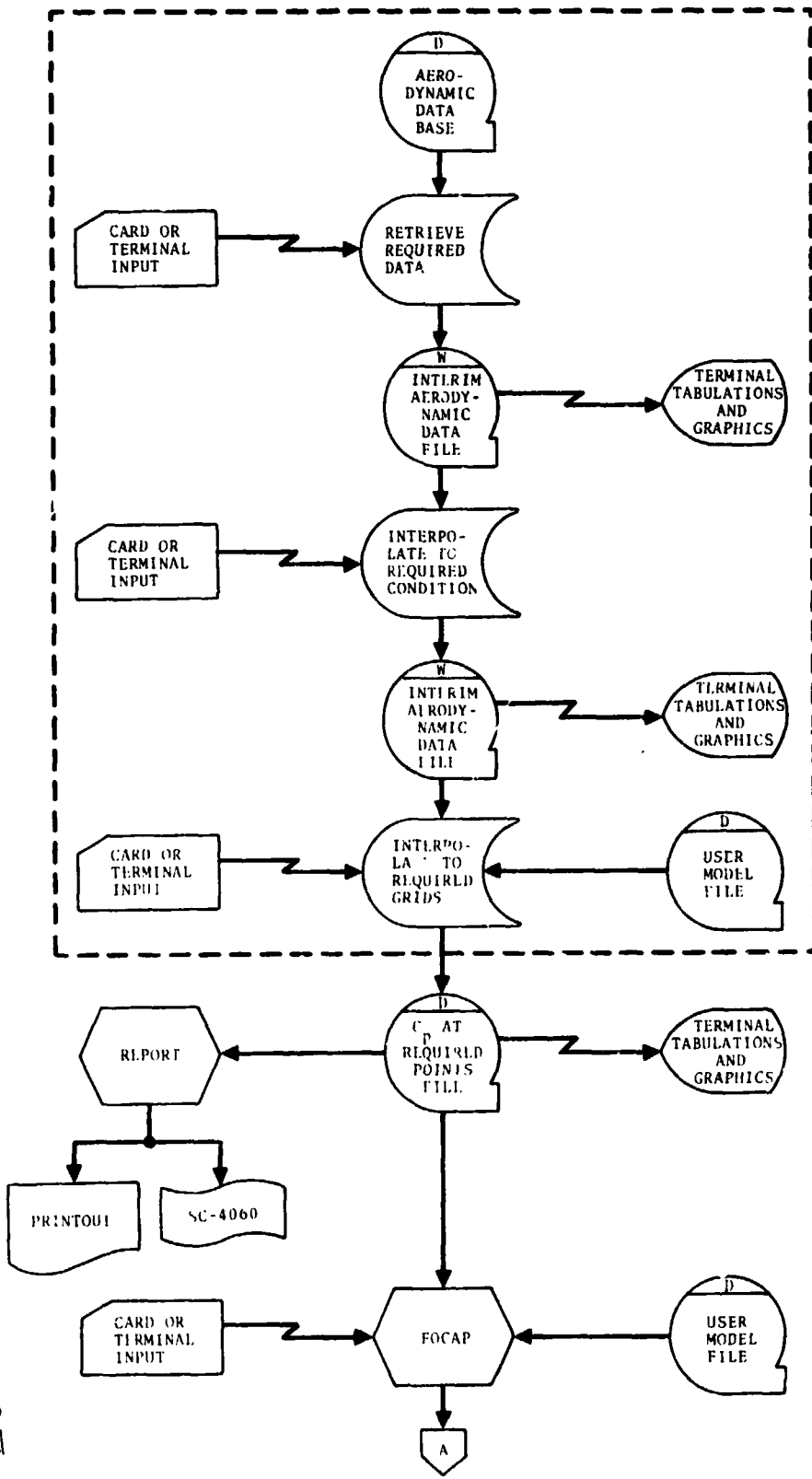

ORIGINAL PAGE IS
OF POOR QUALITY

Figure 4.3-1. - Data flow diagram for Aerodynamic Loads.

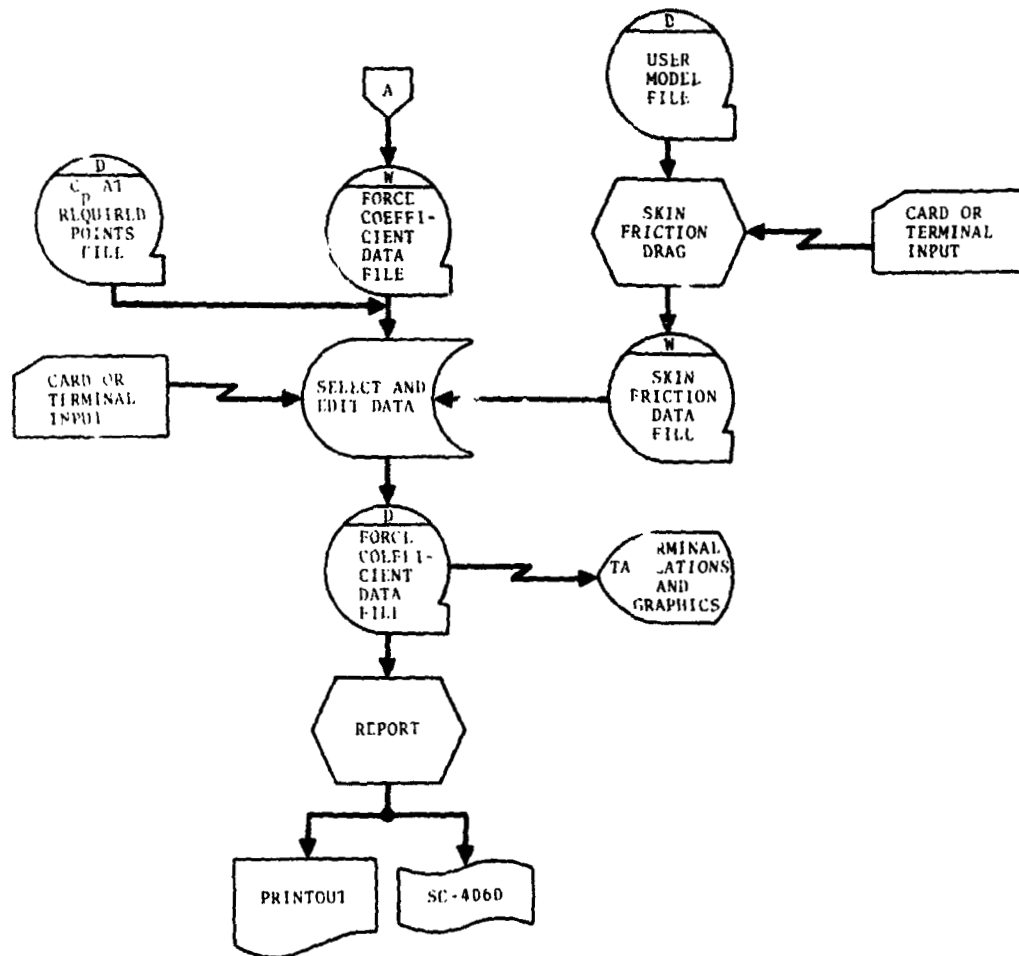

ORIGINAL PAGE IS
OF POOR QUALITY

Figure 4.3-1. - Data flow diagram for Aerodynamic Loads (concluded).

4.4 AIRCRAFT FLIGHT CONDITIONS

4.4.1 PURPOSE

This function will allow the user to simulate the Space Shuttle Orbiter maneuvering in the atmosphere and to calculate flight parameters at incremental time points. The user will operate in the demand mode from a remote terminal and will have the ability to (1) retrieve stored input data from files, (2) display and modify this input at the console, (3) submit the batch program for execution, and (4) display the program output in graphical form at the console.

A Batch Flight Conditions File will be created by the Aircraft Maneuvers Program in order to store the results. This file will be accessed to display the output at the terminal and to produce reports. Figure 4.4-1 is a data flow diagram for the Aircraft Flight Conditions function.

4.4.2 INPUT

Input for this function will be obtained from the following sources.

- Basic Data File
- Force Coefficient Data File
- Standard Atmosphere File
- Keyboard input at the terminal

The input will be stored in a temporary Aircraft Flight File. This file will be used as input to the Aircraft Maneuvers Program.

4.4.3 PROCESSING

From the demand terminal, ISAS will interactively guide the user in the preparation of his input. The Basic Data File,

the Aerodynamic Data Base, and the Standard Atmosphere File will be referenced as needed to assemble the input data for the program. A detailed description of the required input values for the Aircraft Maneuvers Program can be found in the program documentation.

Additional input can be typed into the terminal directly from the console keyboard. The input will be tabulated and displayed on the console so that the user can review his input and make any desired changes. Figure 4.4-2 is an example of the displays which will be available for each case. For each configuration, the following curves for alpha (pitch angle) versus force coefficient can be displayed in tabular form.

1. Alpha versus C_A for each beta (yaw angle)
2. Alpha versus C_Z for each beta
3. Alpha versus C_M for each beta
4. Alpha versus delta C_A for each elevon deflection
5. Alpha versus delta C_Z for each elevon deflection
6. Alpha versus delta C_M for each elevon deflection

An example curve for alpha versus C_A for each beta is given in figure 4.4-3. Hardcopies of these displays may be obtained for report purposes.

The input will be stored in a **Input Flight Conditions File** to be used by the Aircraft Maneuvers Program. The program will be executed and output will be stored in the **Batch Flight Conditions File** and an **Aircraft Plot Data File**.

The Aircraft Plot Data File will contain curves of output parameters versus time. These curves can be plotted directly by the batch program or displayed on the console screen. Table 4.4-1

contains a list of the 16 displays that will be available. Each consists of three plots of different variables versus time in seconds. The output can also be shown in tabular form. This will consist of all parameters calculated at a particular time interval, as shown in figure 4.4-4. All of the displays can be obtained in hardcopy form also.

4.4.4 OUTPUT

The Batch Flight Conditions File will contain data to be used by other ISAS functions. It will be reformatted by REFOR, the Flight Conditions Reformat Function, to generate the ISAS Flight Conditions File.

Console output for this function will consist of tabular displays of the input and output. Plots of the output values will be available as detailed in table 4.4-1. The plot data will be stored in an Aircraft Plot Data File. All terminal displays will also be available in hardcopy form as computer printouts or SC-4060 plots.

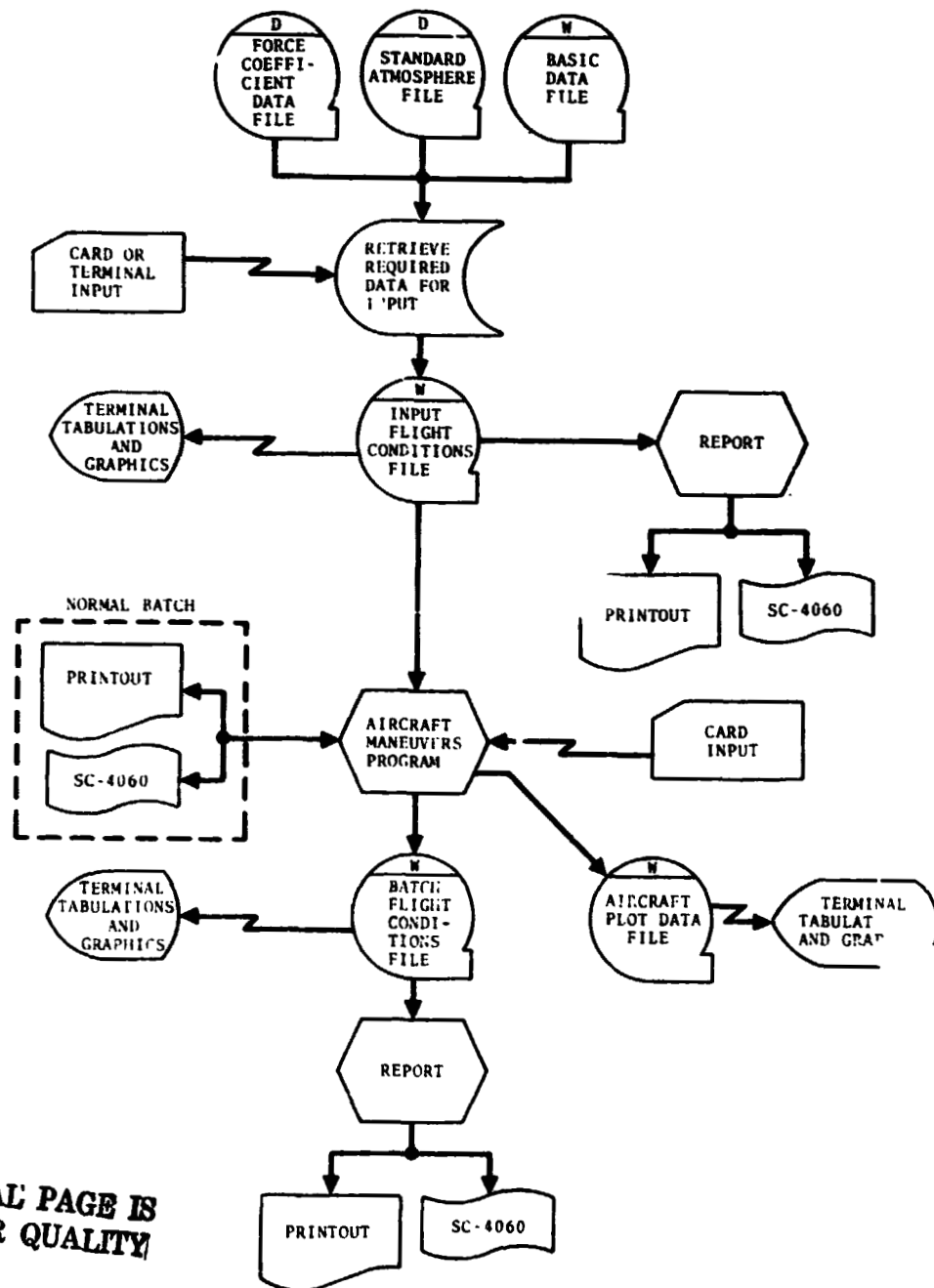

ORIGINAL PAGE IS
OF POOR QUALITY

Figure 4.4-1. - Data flow diagram for Aircraft Flight Conditions.

CASE NO. X
 XXXXX ALL INPUT LENGTHS ARE FEET XXXXX

IMODES	IWIND	IEULER	WAREA	CBAR	DREF
0	-2	0	.117500+04	.139800+02	.904300+02
TMAX	DT	TIME	RADIUS		
.600000+02	.100000+02	.000000	.209035+08		
H	GRAV	THRUST	VREL	ALPHA	BETA
.420000+05	.321700+02	.000000	.455000+00	.872665+00	.000000
PHI	THA	PSI	PHID	THAD	PSID
.000000	-.146608+01	.000000	.000000	.000000	.000000
AX	AY	AZ	TMX	TMY	TMZ
-.338100+00	-.224043+01	-.486700+01	-.177630+00	-.355300+00	.160440+00
AZD	TAYD	DELTAD	AXO	AZO	TAYO
.710500+00	.244020+01	.000000	-.560000-01	-.190000+00	-.460570-01
UGUST	WMASS	XBAR	YBAR	ZBAR	
.000000	.404103+04	.691100+02	.000000	-.106000+01	
		PINERT			
	.764300+06	.000000	.000000		
	.000000	.367360+07	.000000		
	.000000	.000000	.385740+07		

4-37

Figure 4.4-2. - Display example for Aircraft Flight Conditions function.

ALPHA VS. CA

MACH = _____

BETA = $-.174533+00$

BETA = $.000000$

BETA = $.174533+00$

ALPHA	COEF.	ALPHA	COEF.	ALPHA	COEF.
$-.349066+00$	$-.118760+01$	$-.349066+00$	$-.118760+01$	$-.349066+00$	$-.118760+01$
$-.261799+00$	$-.950000+00$	$-.261799+00$	$-.950000+00$	$-.261799+00$	$-.950000+00$
$-.174533+00$	$-.615200+00$	$-.174533+00$	$-.615200+00$	$-.174533+00$	$-.615200+00$
.
.
$.113446+01$	$.290020+01$	$.113466+01$	$.290020+01$	$.113446+01$	$.290020+01$
$.122173+01$	$.292600+01$	$.122173+01$	$.292600+01$	$.122173+01$	$.292600+01$
$.130900+01$	$.289610+01$	$.130900+01$	$.289610+01$	$.130900+01$	$.289610+01$

Figure 4.4-3. - Example curve for alpha versus C_A for each beta.

TIME 0.0

ALT	MACH	PRESS	DENSTY	TEMP	QBAK
.420000+05	.458774+00	.357229+03	.533649-03	.389988+03	.526312+02
ALPHA	BETA	DELT	VWX	VWY	VWZ
.500037+02	-.113549+02	.200015+02	.000000	.000000	.000000
VRELX	VRELY	VRELZ	U	V	W
.283132+03	-.568532+02	.337423+03	.283132+03	-.568532+02	.337423+03
NXDD	NYDD	NZDD	VREL	GIM	THRUST
-.364707-02	-.211202+00	.107593+01	.444128+03	.000000	.000000
UDOT	VDOT	WDOT	XCAP	YCAP	ZCAP
-.324535+01	.679437+01	-.261899+01	.209455+08	.000000	.000000
PHI	THA	PSI	P	Q	R
.000000	-.146608+01	.000000	.000000	.000000	.000000
XCAPD	YCAPD	ZCAPD	PHID	THAD	PSID
-.305979+03	-.568532+02	.316851+03	.000000	.000000	.000000
PDOT	QDOT	RDOT	TXDD	TYDD	TZDD
.413945+00	.103101-01	-.453106-01	.413945+00	.103101-01	-.453106-01

Figure 4.4-4. - Output tabulation example of all parameters calculated at a particular time interval.

TABLE 4.4-1. - AIRCRAFT MANEUVERS PROGRAM PLOT CAPABILITIES

Plot Number	Variable	Description
1	NXXD NYYD NZDD	Linear accelerations for load computations
2	TXXD TYYD TEDD	Angular accelerations for loads
3	ALPH BETA DELTA	Pitch angle of attack Yaw angle of attack Elevon deflection
4	QBAR MACH VREL	Dynamic pressure Mach number Relative velocity
5	ALT GIM THRUST	Altitude Pitch gimbal angle Thrust
6	VWX VWY VWZ	Be components of flight winds
7	PRSS DENSTY TEMP	Atmospheric pressure Atmospheric density Atmospheric temperature
8	VRE LX VRE LY VRE LZ	X, Y, Z body components of relative velocity
9	U V W	Axial velocity Y-body velocity Z-body velocity
10	UDOT VDOT WDOT	Axial acceleration Y-body acceleration Z-body acceleration
11	P Q R	Roll rate Pitch rate Yaw rate
12	PDOT QDOT RDOT	Rolling acceleration Pitch acceleration Yaw acceleration
13	PHI THA PSI	X-Euler angle Y-Euler angle Z-Euler angle
14	PHID THAD PSID	X-Euler angle velocity Y-Euler angle velocity Z-Euler angle velocity
15	XCAP YCAP ZCAP	X-inertial position Y-inertial position Z-inertial position
16	XCAPD YCAPD ZCAPD	X-inertial velocity Y-inertial velocity Z-inertial velocity

ORIGINAL PAGE IS
OF POOR QUALITY



4.5 AIRCRAFT GUST AND BOOST TURBULENCE LOADS

4.5.1 PURPOSE

This function will allow a user, working in the demand mode from a remote terminal, to prepare input files for various batch programs. Input and output data can be viewed at the terminal in graphical and tabular form. The batch programs will be the Adjusted Aerodynamics Program, Gust Response Program, and Turbulence Response Program. Figure 4.5-1 is a flow diagram showing the subfunctions of the Aircraft Gust and Boost Turbulence Loads.

4.5.2 INPUT

The following six files will be used as input for this function.

- User Modal File.
- Force Coefficient Data File
- Trajectory Data File
- Unsteady Gust Generalized Forces File
- Load Coefficient Data File
- Standard Atmosphere File
- Static Aerodynamic Influence Coefficients File
- Turbulence Spectra File

The user will also be required to enter some data at the terminal via the keyboard.

4.5.3 PROCESSING

The entry point for Aircraft Gust and Boost Turbulence Loads will depend on the user's option to execute the batch Adjusted Aerodynamics Program. If the user intends to run this program, he will enter the function at the top of the flow diagram.

The Aerodynamic Force Coefficient Data File will contain force coefficient data indexed by flight condition. The user will type the file title/ID data and a set of flight conditions (Mach, angle of attack, angle of sideslip, and inboard and outboard elevons). The force coefficient data corresponding to the input flight conditions will be retrieved from the file. If the specified flight conditions are not found in the file, then the ISAS Flight Conditions Interpolation routine will be used to obtain data at the designated flight conditions. The data will be displayed at the terminal in tabulated form, as shown in figure 4.5-2.

The Unsteady Aerodynamic Generalized Forces File will contain grid point numbers and locations, reduced frequencies, Mach numbers, generalized forces, aerodynamic influence coefficient matrix, reference area matrix, downwash matrix, and velocity potential. The generalized forces matrix can be tabulated and displayed on the cathode-ray tube (CRT) as shown in figure 4.5-3.

Formation of a temporary Gust Input File is the next step in the function. Input for this file will be gathered from the six input files. Data can also be entered by the user through the terminal keyboard.

The Trajectory Data File will contain trajectory information for selected Mach numbers. The user will input a Mach number; the time, flight conditions, and type of wind profile will be displayed on the screen.

The Load Coefficient Data File will contain shear and bending moment coefficients for selected vehicle stations. The user can display this data in tabular form and select the desired load stations.

Density as a function of altitude will be retrieved from the Standard Atmosphere File.

Both the Gust Response Program and the Turbulence Response Program will output a Response Output File. The Response Output File will contain the aircraft response to the power spectral density (PSD) function for the various load conditions. In addition, it will contain shear and bending moments, frequencies, load station coordinates, root mean square integral of PSD (σ^2), and number of times per unit time a load will be exceeded (N_0). An example of tabulations and graphics to be displayed for this file is shown in figure 4.5-4.

4.5.4 OUTPUT

The output for this function will consist of graphical plots, data tabulations, and output files. The plots and tabulations, described in the previous section, will be displayed on the screen at the remote terminal.

Files created by this function will be:

- Unsteady Aerodynamic Generalized Forces File
- Response Output File
- Combined Data File
- Gust Input File

Descriptions of these files can be found in the appendix.

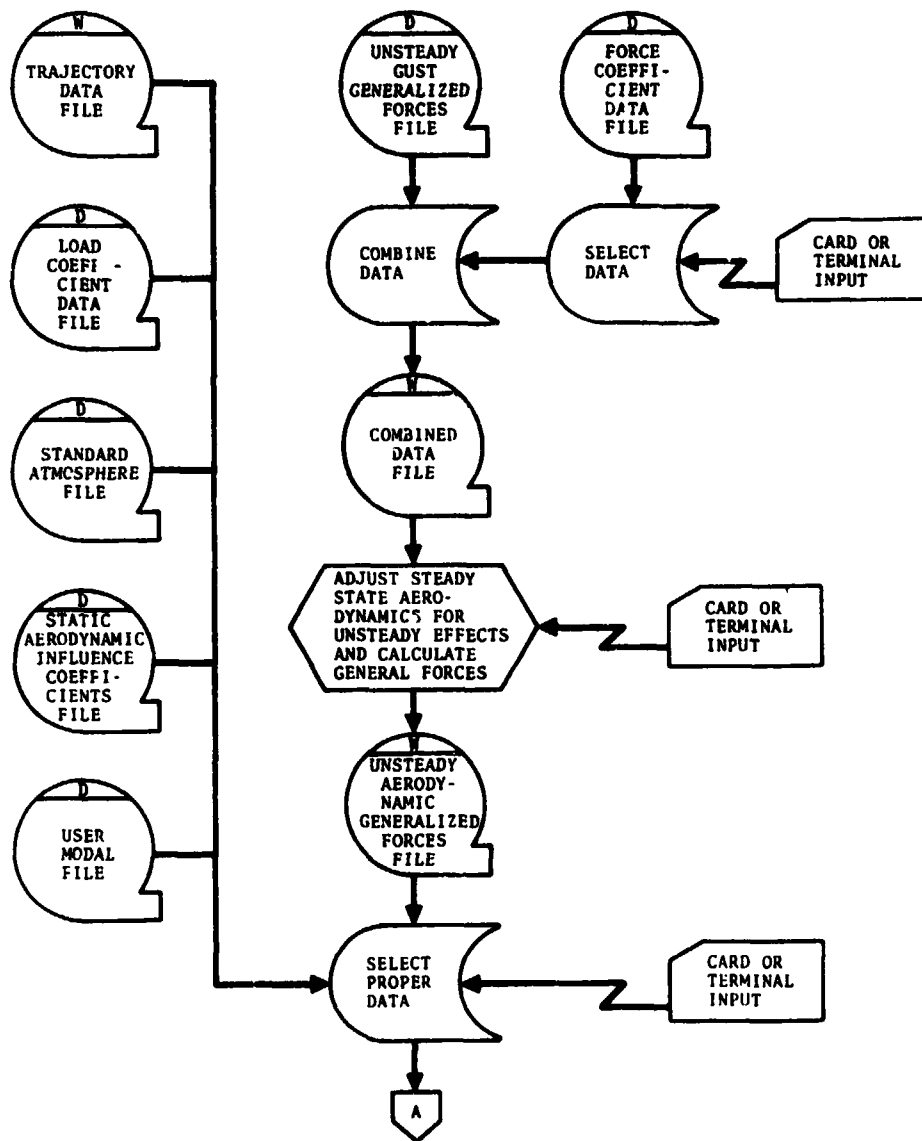

ORIGINAL PAGE IS
OF POOR QUALITY

Figure 4.5-1. - Data flow diagram for Aircraft Gust and Boost Turbulence Loads.

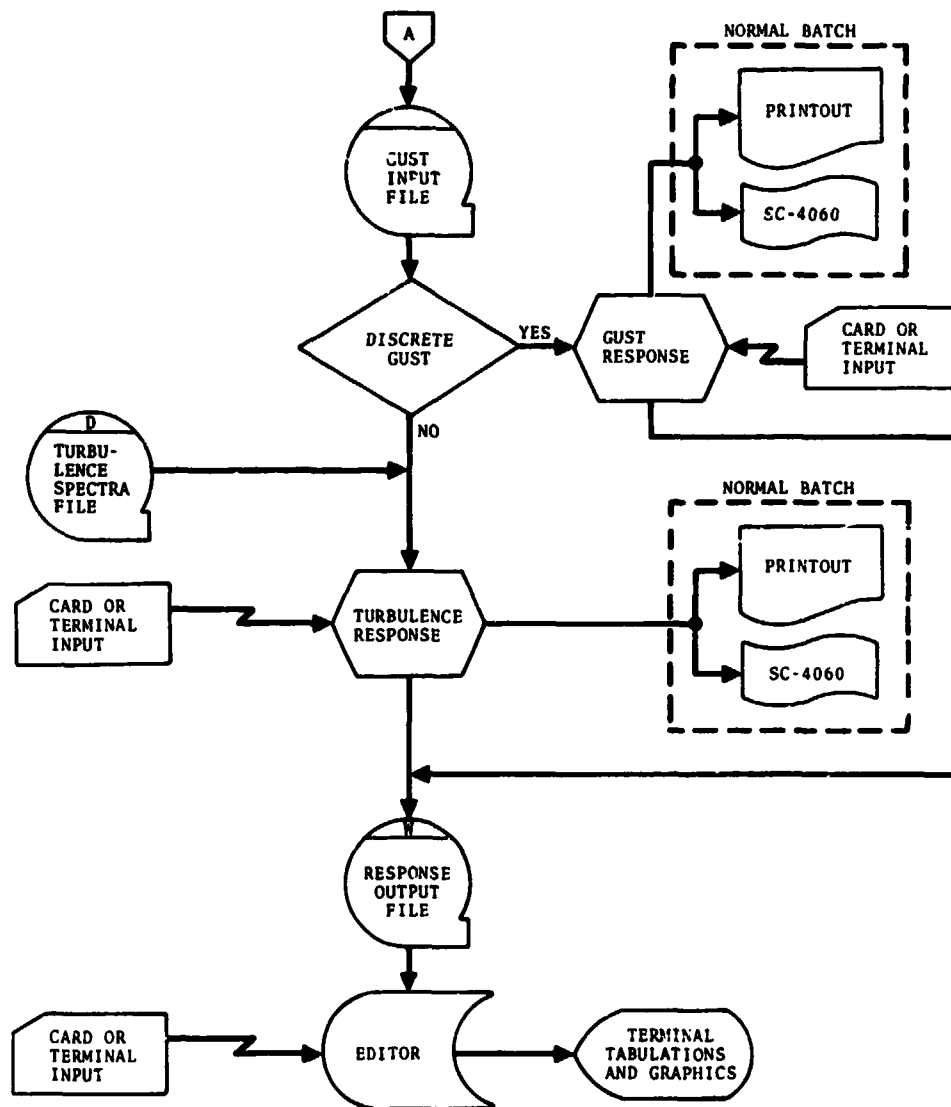

ORIGINAL PAGE IS
OF POOR QUALITY

Figure 4.5-1. - Data flow diagram for Aircraft Gust and Boost Turbulence Loads (concluded).

FORCE COEFFICIENT DATA

MACH NO. = X.XXX ALPHA = XX.XXXX REF. AREA = XXXX.

GRID POINT N	LOAD STATION			FORCE			MOMENT	
	X	Y	Z	FX	FY	FZ	MX	MY
.
.
.

Figure 4.5-2. - Force Coefficient Data File tabulation format.

UNSTEADY AERODYNAMICS GENERALIZED FORCES

MACH NO. = X.XXX

RED. FREQUENCY = XXXXX

GRID POINT NUMBER	1		2	
	R	I	R	I
1
2
.
.
.

Figure 4.5 3. - Generalized forces matrix example.

RESPONSE OUTPUT

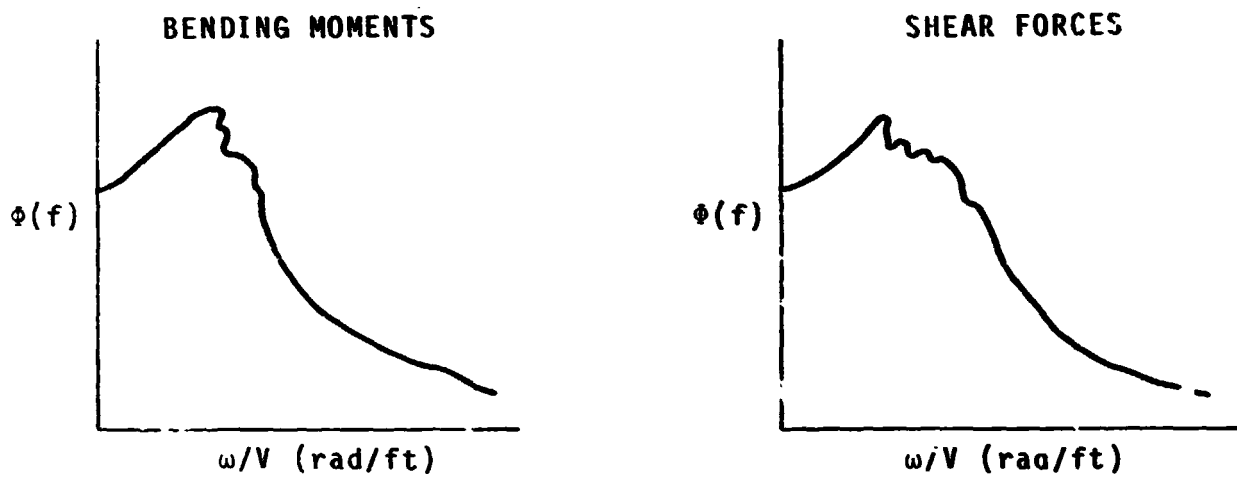

STATION			σ^2	σ	N_0
X	Y	Z			
.
.
.

Figure 4.5-4. - Tabulations and graphics displayed for the Response Output File.

4.6 AERODYNAMIC CALCULATIONS FOR WING AND BODY ELEMENTS

4.6.1 PURPOSE

This function will provide an interactive interface to the Analytic Pressure Distribution (ACE) program. The ACE Program will calculate pressure coefficients at points on a flight vehicle for a specified aerodynamic condition. Data from ACE will be used to supplement other pressure coefficient data on the wing and vertical tail surfaces. In addition, the program will calculate and create an ISAS file of rigid wing aerodynamic coefficients as required by the Static Aeroelasticity Program. Figure 4.6-1 is a data flow diagram for this function.

4.6.2 INPUT

The input will consist of the User Model File and data entered by the user from the terminal. This data will be of two types - data input for the ACE Program and data entered to guide the processing and graphical displays of the function.

4.6.3 PROCESSING

The first step in the processing of this function is to build the ACE Data File, which will be used as input to the ACE Program. The terminal user will be requested to enter the names of data files to be used for input. These will include:

1. User Model File which the user will be able to review as a reference for adjusting his input data. If the User Model File is requested, the terminal user will be able to view the file contents (the structural model definition) on the terminal screen.
2. File where the user ACE input data are stored. The user will be able to call up this file, view it on the screen, and make modifications to the data. The user will be able to store the modified input file with the same file name or store it as a new file.

The terminal user will also have the capability of entering the entire ACE input data at the terminal. When the user is satisfied with the input data on his file, he will be able to designate a file as the ACE Data File. The ACE Data File will be the input to the ACE Program. The user will be able to view the ACE Data File at the terminal and make any final modifications needed. The user may request a printout of the ACE Data File.

The second step in the processing of this function will be initiating the execution of the batch program ACE. Here, the user will be requested to name the ACE Data File, name the output files, and specify which types of output are desired.

First, the terminal user will be requested to enter the file name of the ACE Data File if it has not been created in the previous step of this function. Second, the user will select from a menu the options available for executing ACE:

1. Normal batch processing of the program
2. Generating the Aerodynamic Influence Coefficients File
3. Generating the ACE Output Data File with a report-form printout

If the user selects normal batch processing, the ACE Program will execute normally, and standard output and plots will be produced.

The user may choose instead to create one or both of the ISAS output files (2 and 3 above), view tabulations and graphical displays of these files, and have program output generated in report form.

The first file that can be generated by the ACE Program will be the Aerodynamic Influence Coefficients File. This file will output coefficients versus panel control points for use by the Static Aeroelasticity Program. After the user specifies that he wants this file to be generated, he will be requested to enter the file name to be used. The file will be generated during the execution of ACE. After the file is produced by ACE, the user will be able to display the contents of the file at the terminal screen. The form of this display will show the coefficients versus panel control points in a table with headings. After viewing the file, the user will have the option of storing it as the Aerodynamic Influence Coefficients File or releasing it. If the user does not store the file, he will be able to return to the beginning of the function to form another ACE Input File.

The second file that can be generated by the ACE Program will be the ACE Output Data File. The file will contain pressure coefficients at panel control points for upper and lower wing and delta pressure coefficients (ΔC_p) at each control point. After the user specifies that he wants the file to be generated, he will be requested to enter the file name to be used when storing the file. The file will be generated during the execution of ACE. After the file is produced by ACE, the user will be able to select from a menu the type of display to be generated. Display options will include:

1. Tabular output of pressure coefficients versus panel control points displayed at the terminal
2. Plots of pressure coefficients versus panel control points displayed at the terminal.
3. ACE Program output in report format

If the user chooses option 1 or option 2, he will then select the specific tabulations from a menu of available choices.

These will be:

- Upper wing C_p versus panel control points along wing chords
- Lower wing C_p versus panel control points along wing chords
- ΔC_p versus panel control points along wing chords
- Upper wing C_p along the percent span
- Lower wing C_p along the percent span
- ΔC_p along the percent span
- Upper wing C_p on the span
- Lower wing C_p on the span
- ΔC_p on the span
- Upper wing C_p along percent chord
- Lower wing C_p along percent chord
- ΔC_p along percent chord

For the tabulations, the user will be able to enter a descriptive heading at the terminal. Mach number and angle of attack will also be displayed on the tables.

For the plots, the user will be able to enter a descriptive heading at the terminal. Mach number and angle of attack will be displayed on the plots. An example of the basic form of the plots is shown below:

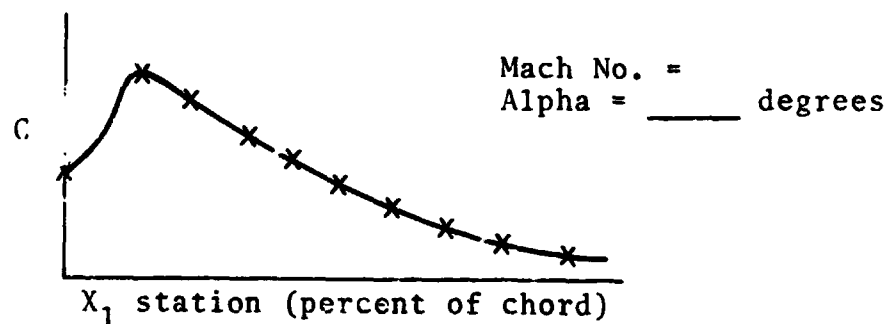

If the user selects option 3, the ACE Program output and plots will be generated in a format suitable for report documents.

4.6.4 OUTPUT

The following files will be available for output:

- Aerodynamic Influence Coefficients File
- ACE Output Data File
- ACE Data File

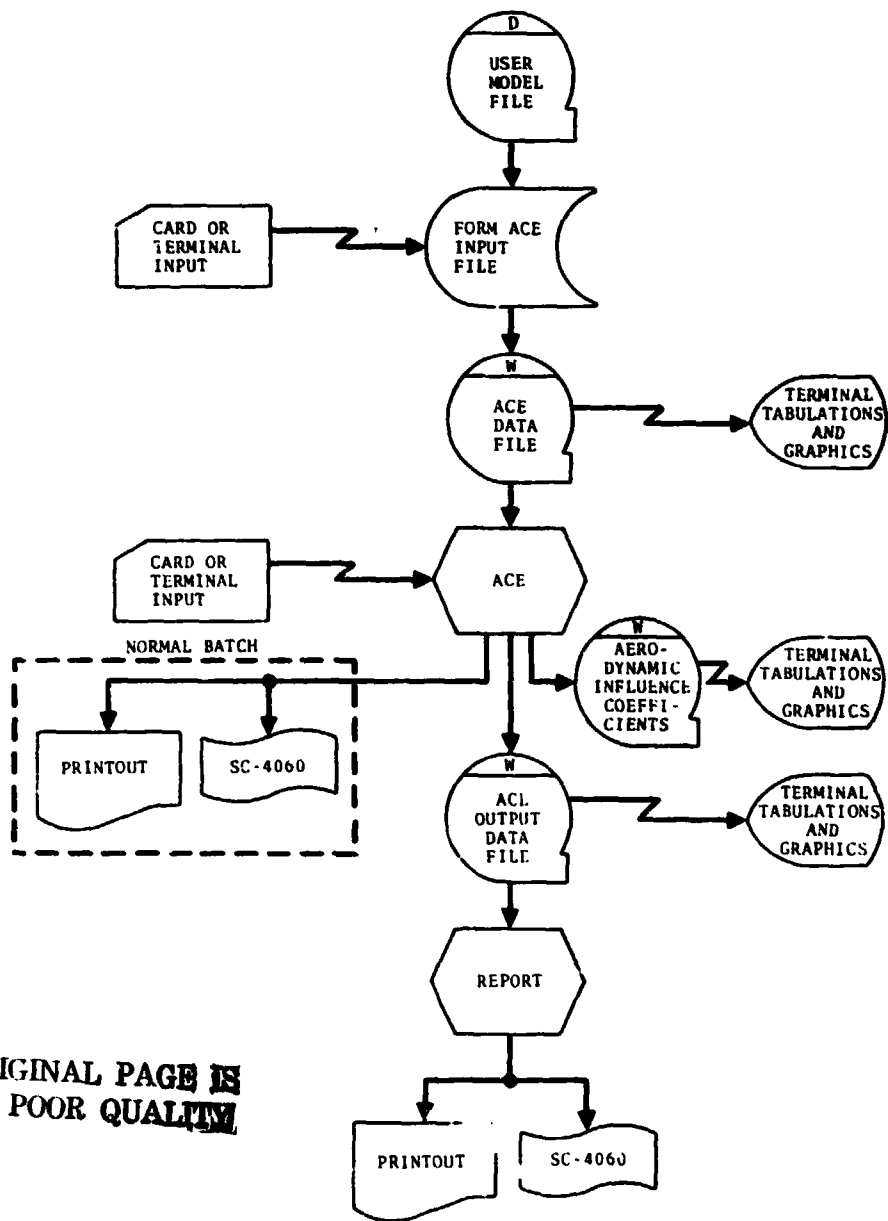

ORIGINAL PAGE IS
OF POOR QUALITY

Figure 4.6-1. - Data flow diagram for Aerodynamic Calculations for Wing and Body Elements.

4.7 BASIC GEOMETRY FILE GENERATOR

4.7.1 PURPOSE

The Basic Geometry File Generator function will create a file containing the surface functions or control points necessary to analytically describe the geometric surfaces of a model. Basic curve definitions will be input to the program, and either regularly shaped shells of revolution* or the milling machine lofting routine FMILL[†] will be used to refine the surface definitions to the desired degree. Figure 4.7-1 is a data flow diagram of the Basic Geometry File Generator function.

4.7.2 INPUT

There will be two sources of input to this program.

1. Card image input of X, Y, and Z coordinates defining curves along the surface.
2. Interactive terminal input. This terminal input may be divided into two types, keyboard and display selectable (light pen).
 - a. Terminal keyboard entries
 - Structure, substructure, and region identification
 - X, Y, and Z coordinate definition of basic curves
 - X, Y, and Z direction cosines of tangents to stringers and curves
 - Dimensions and mesh sizes for shells of revolution
 - Mesh sizes for FMILL

*Theoretical Elastic Stress Distributions in Cassinian Domes. NASA TN D-1741 (The key equations of interest were expanded by Dr. Frederick J. Stebbins to encompass seven shells of revolution.)

[†]APT Encyclopedia, Program Reference Manual, UNIVAC 1106 to 1108, UP4078, rev. 2, pp. 9D-1 through 9D-15.

- Bulkhead sizing
- Visual aid definitions such as cutting planes

The card image input may be omitted and the terminal used to enter all input, or a combination of terminal keyboard and previously created card files may be used.

b. Display selectable input (light pen)

- Cutting plane positioning
- Control point positioning
- Control point selection for region definition

The terminal user will be led through the interactive graphics program with questions and prompting messages tailored to give the user detailed assistance in stepping through the procedure. Some representative examples of display selectable input are given in figure 4.7-2.

4.7.3 PROCESSING

The Basic Geometry Data File will be created by defining the contours of the model in terms of X, Y, and Z coordinates of control points, direction cosines, and local slopes along the surface.

An interactive graphics terminal will be used to display in a graphical form the control points and lines connecting the control points. This program will contain capabilities which will be inherent to interactive graphics terminal usage. These capabilities will include:

- Display of control points
- Display of lines connecting these control points
- Creation, deletion, and modification of the control points and the lines connecting them
- Means to loop back through the program

- Dialogue in the form of questions and suggestions initiated by the program
- Interpretation of user response to dialogue
- Ability to break (or terminate) the program at any stage and restart it at a later time

The program should also include the capabilities to generate tabular display and allow editing. The program must be constructed so that sequential processing may be accomplished readily with a minimum of user interaction.

The first step required in the processing function will be the dynamic file assignment of the Basic Geometry Data File. Once this is completed, the user must be allowed to enter control points via a card file, the remote terminal, or a combination of both methods.

If there is an input card file, it will be read and the surface defined by it will be displayed. If no card file exists, the user will enter the basic curve definitions by means of the keyboard and/or other input devices. The keyboard entries will consist of the X, Y, and Z coordinates or delta X, Y, and Z values from a defined point. The tracking cross may be used to define points after a reference point and scale have been established.

When building a Basic Geometry Data File, it will be necessary to define the control points as structure and substructure components. Particular groups of points will be divided further into regions so that the model hierarchy is of the form shown on the following page.

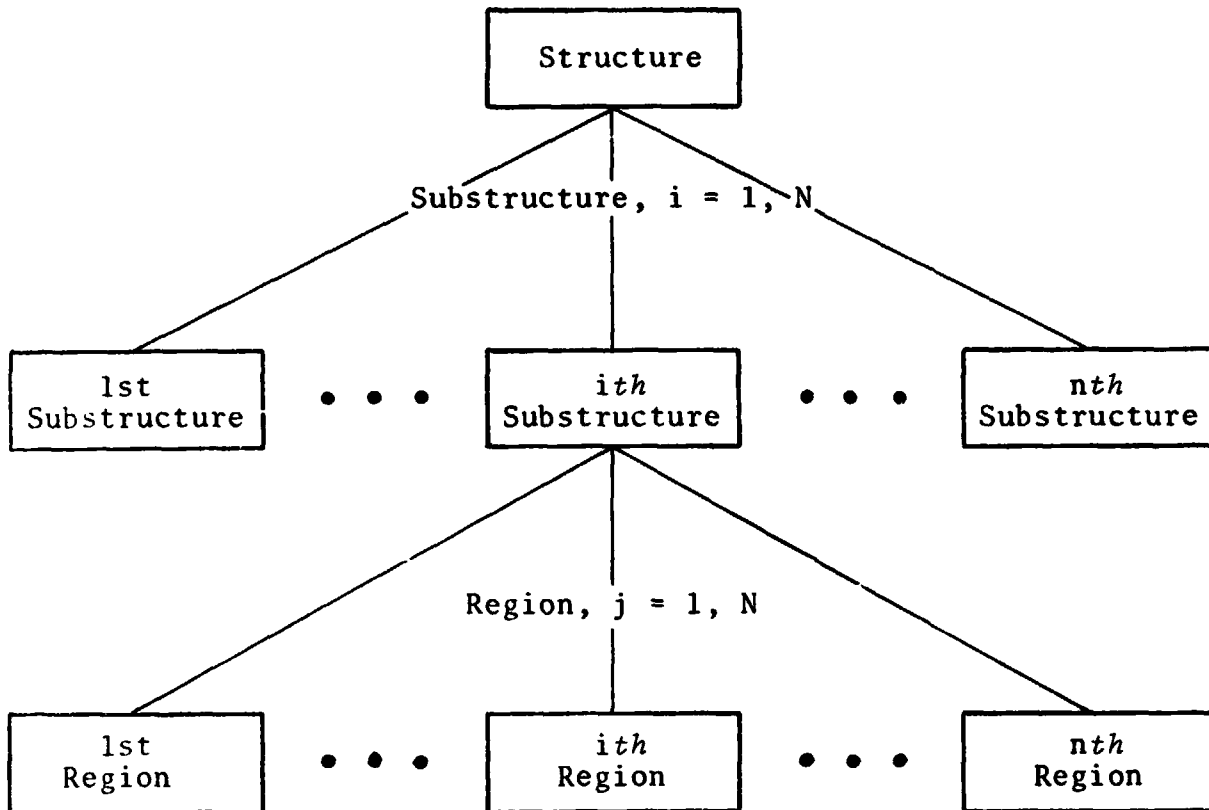

Initially the terminal user will be asked to input through the terminal keyboard the identification (1 to 15 alphanumeric characters) of the structure and substructure. Display selectable menu items will be provided for subsequent structure and substructure identification. The same type of identification method should be used for regions.

The program should allow for the specification of cutting planes and alteration of the view at any stage of the surface development to assist with the surface definition and to verify its contour. The cutting planes can be established as normal to a coordinate axis by specifying the control coordinates. The user should be allowed the following three methods to select skewed cutting planes:

- Inputting angles of rotation from the coordinate axes

- Identification of three points in the skewed plane
- Specification of the X, Y, and Z coordinates of two points of the normal to the skewed plane

Once a cutting plane has been established, the trace it makes with the surface should be displayed by selecting the plane and display option. The view-altering capability must include rotation, displacement, and enlargement.

The trace formed by the cutting plane and the model surface may reveal a need for additional surface points. Two methods of obtaining additional points will be available depending upon the regularity of the model surface geometry.

Shells of revolution will be defined analytically, and thus additional points can be obtained by redefinition of the regular shape through input parameters. The number of meridional and circumferential divisions desired will be the pertinent parameters. The seven shells of revolution to be so treated are (1) cone, (2) disk, (3) cylinder, (4) Cassinian surface, (5) elliptical surface, (6) sphere, and (7) torus.

Irregular surfaces will be defined by a conic lofting program, FMILL. The coordinates of known points (called control points) will be input to FMILL. These control points will describe a mesh. The degree of resolution desired will be specified by FMILL input parameters which will subdivide each unit of the mesh through additional points calculated on the conic surface.

The surface generated by the preceding methods will be displayed, permitting the user to visually inspect the contour. He may elect to display concurrently surfaces previously defined and by remaining control points. Also, he may display in numeric form coordinate values and slope values of selected points.

These values can be modified or used as calculated for reinput to the surface fitting routines to refine further the surface definition or to obtain a desirable match-up of region boundaries where discontinuities exist.

Inner mold surfaces should be obtained in a similar manner; i.e., in one of two ways, (1) by describing inner surfaces using FMILL or shells of revolution or (2) by expressing bulkheads in terms of distance along normals to the outer surface.

The interactive input techniques; the altered view capability; and the ability to display and modify surface coordinates, curve tangents, and surface tangents will be the important features of this function. They will provide the user the capability to define and uniquely identify all regions (including substructures) of the geometry of a model to be analyzed. Once the user is satisfied that the model meets the desired degree of definition, the Basic Geometry Data File will be ready for use in analysis.

4.7.4 OUTPUT

The Basic Geometry Data File will be the major output from this ISAS function. A complete description of this file can be found in the appendix of this document. As described in section 4.7.3, graphical outputs are required.

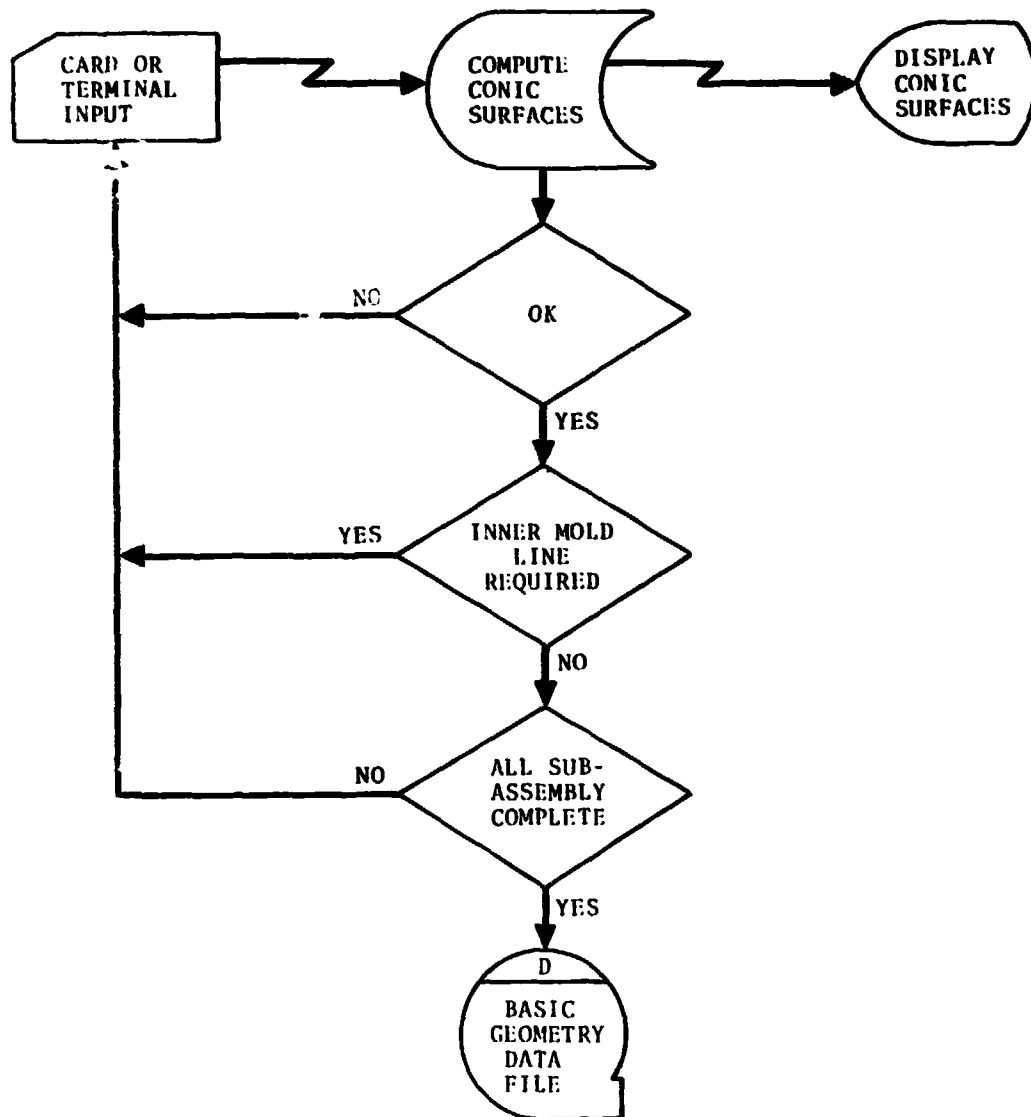

Figure 4.7-1. - Data flow diagram for Basic Geometry File Generator

C.2

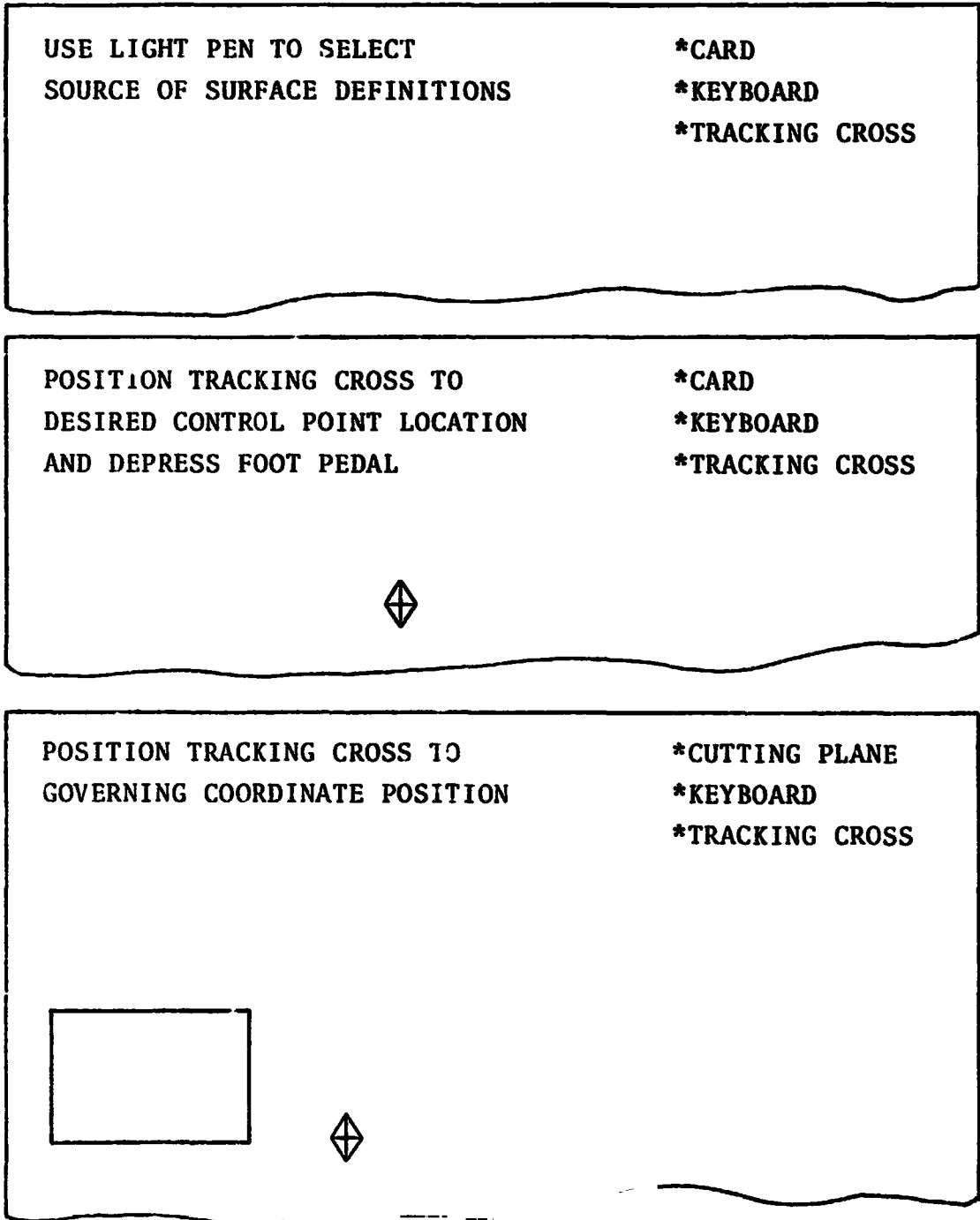

Figure 4.7-2. - Examples of display selectable input.

4.8 BASIC STRUCTURAL DIMENSIONS

4.8.1 PURPOSE

This function will generate gross model structural geometry data to be used by the Properties and Allowables function in computing buckling analyses and/or section allowables. The Basic Structural Dimensions File will be independent of the User Model File and will contain only basic structural dimensions and coordinates. It is assumed, however, that the input to this function will use the same coordinates, in general, as the User Model File. Figure 4.8-1 is a data flow diagram of the Basic Structural Dimensions function.

4.8.2 INPUT

All input to this function will make use of the interactive device of the system. The user will be required to define the structure being modeled in terms of regions, stations within each region, strategic coordinates within the region, and pertinent section properties data.

4.8.3 PROCESSING

The basic types of structure to be treated in this function will be stiffened skin panels and beams. An example of these types of structure are shown in figures 4.8-2 and 4.8-3. The program will also have the capability to accept other configurations (free form) in the pure manual mode. The user will input his choice between stiffened panels, beams, and free form. If the choice is a stiffened panel, the user must also select a panel configuration from the displayed list of stiffened panel concepts (see fig. 4.8-4). A maximum of 16 concepts will be allowed for panels and 1 for beams. The program will then ask the user to define the number of regions required to describe the structure being modeled. It is assumed that 30 regions should be sufficient to describe any structure. After the configuration

and the number of regions have been input, the program will generate a tabular format, which will conform to the type of structural configuration selected earlier. Examples of these formats are shown in figures 4.8-5 and 4.8-6.

The regions should be updated in an automatic fashion as each region is completed. The user will then be asked for the number of stations that will be defined within each region. It is assumed that a maximum of 150 stations per region should be sufficient to describe the structure. The program will then fill in the table with region numbers and the station numbers in each region. Values should be input for the X, Y, and Z coordinates and the geometry parameters (b, t, R, ϕ) listed on the display for each station in the region.

For the beam problem, the user will be required to break the beam cross section into subelements as shown on figure 4.8-7. It is assumed that a maximum of 20 subelements should be sufficient to describe most sections. When all of the data for a region is completed, it will be output into the Basic Structural Dimensions File. The program will then recycle and allow the selection of another region. After all of the regions of a structure have been completed, the user will have the option to start another structure.

4.8.4 OUTPUT

The primary output from this function will be the Basic Structural Dimensions File, containing all of the data which will be developed as described in section 4.8.3. A complete description of the format and contents of the file can be found in the appendix.

Other output will be graphical displays of the chosen configuration of figures 4.8-4 and 4.8-7, graphical displays of each

station, and tabular listings of the data. The graphical displays at each station will be patterned after figures 4.8-4 and 4.8-7 and will be scaled to the actual data. Figure 4.8-8 is an example of the tabular display. The format of this display will vary with the type of panel or beam.

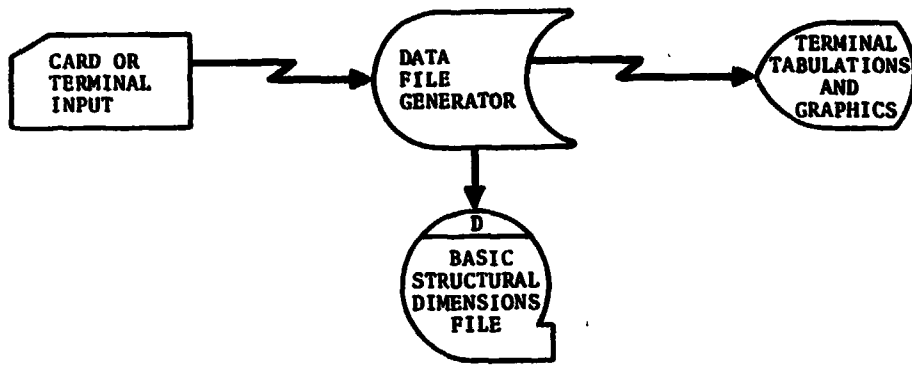

Figure 4.8-1. - Data flow diagram for Basic Structural Dimensions.

ORIGINAL PAGE 15
OF POOR QUALITY

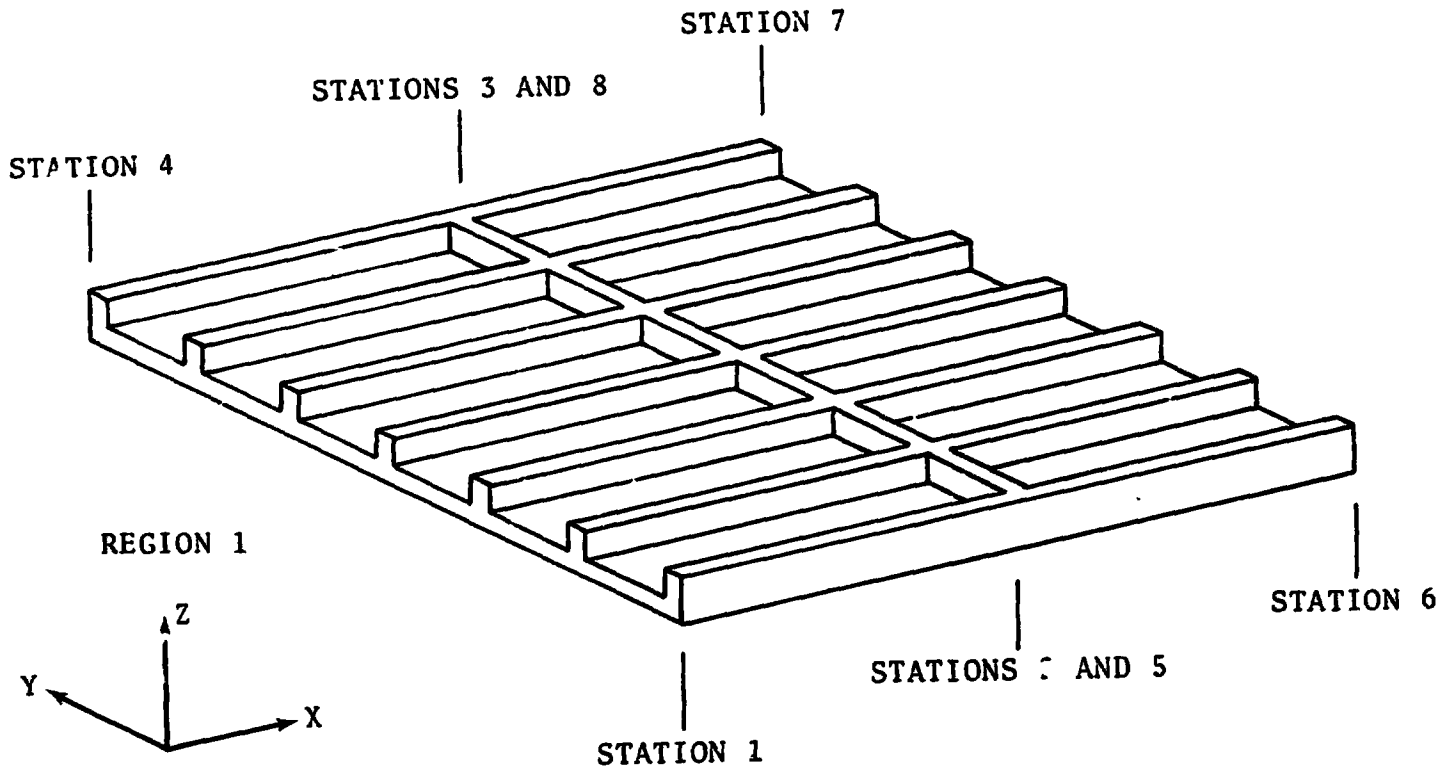

Figure 4.8-2. - Generalized stiffened panel concept.

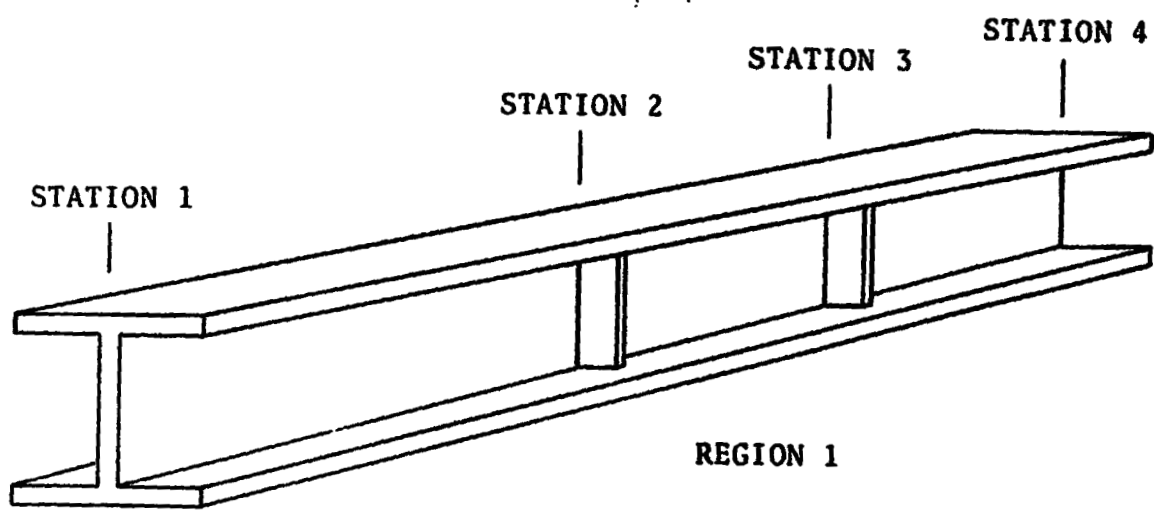

Figure 4.8-3. - Beam concept.

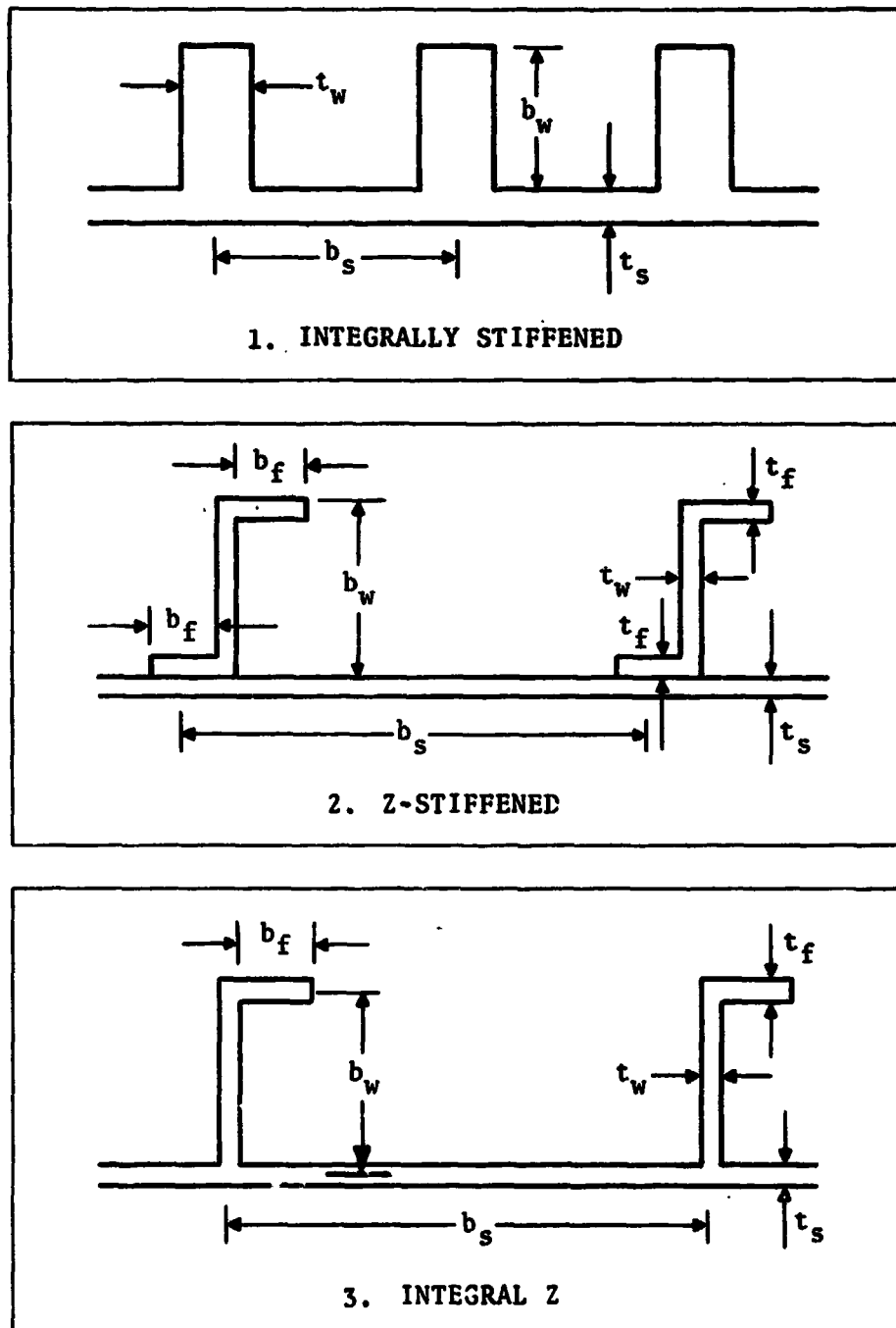

Figure 4.8-4. - Sixteen stiffened panel configurations.

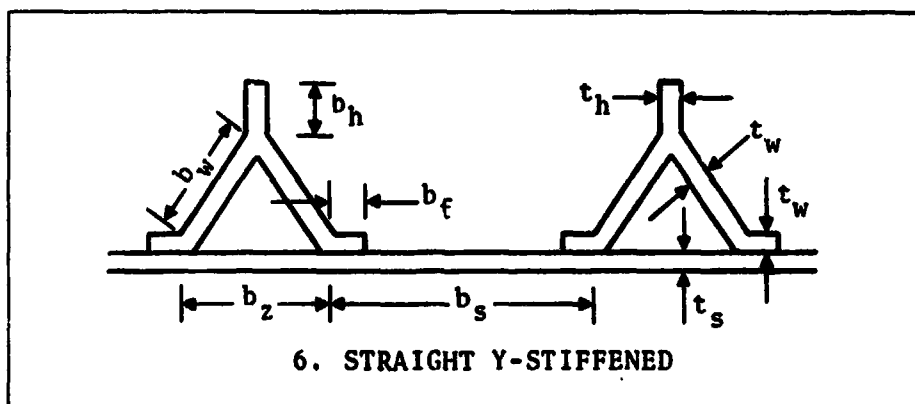
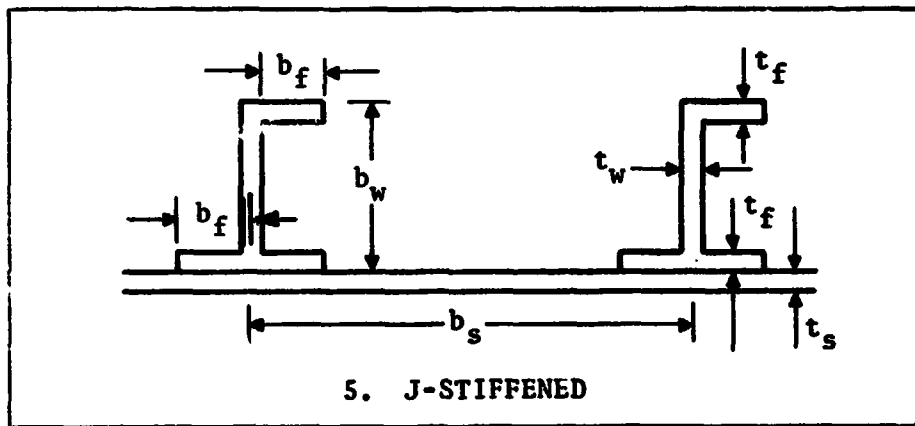
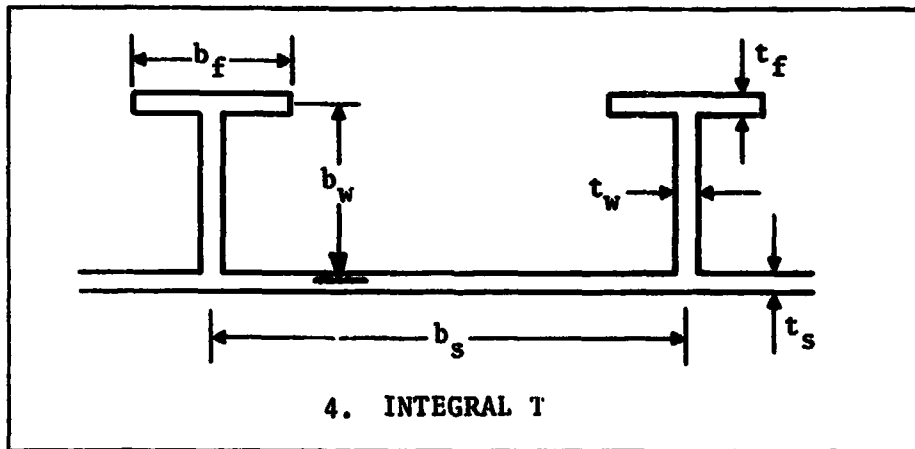

Figure 4.8-4. - Sixteen stiffened panel configurations (continued).

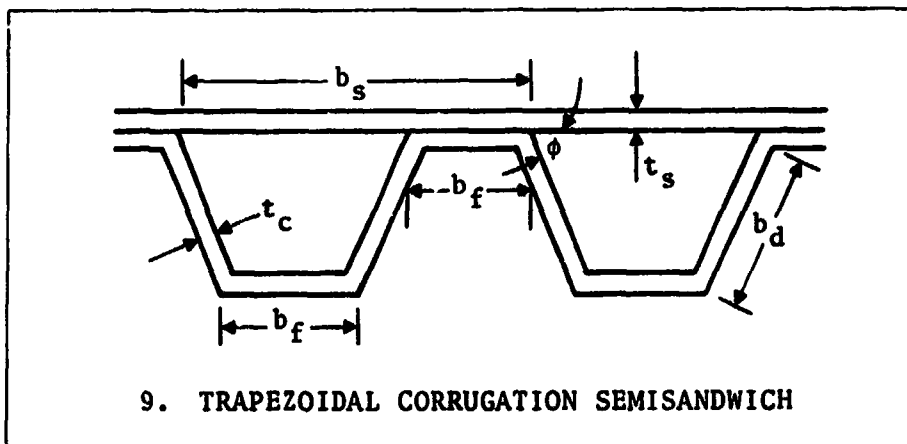
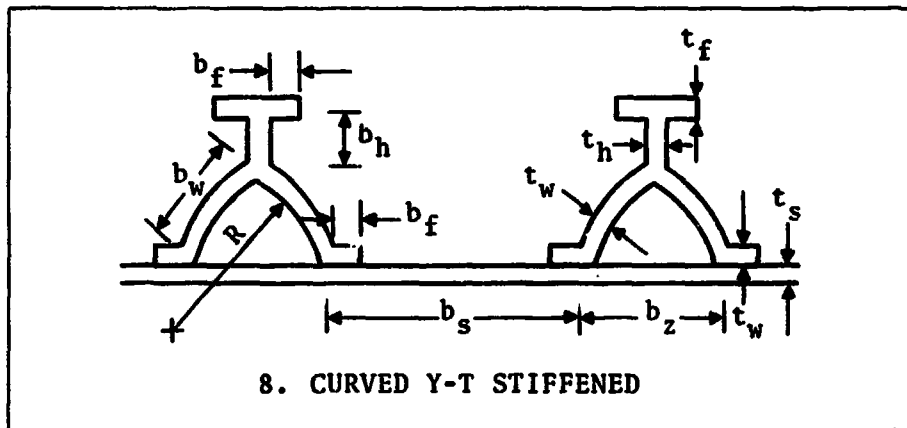
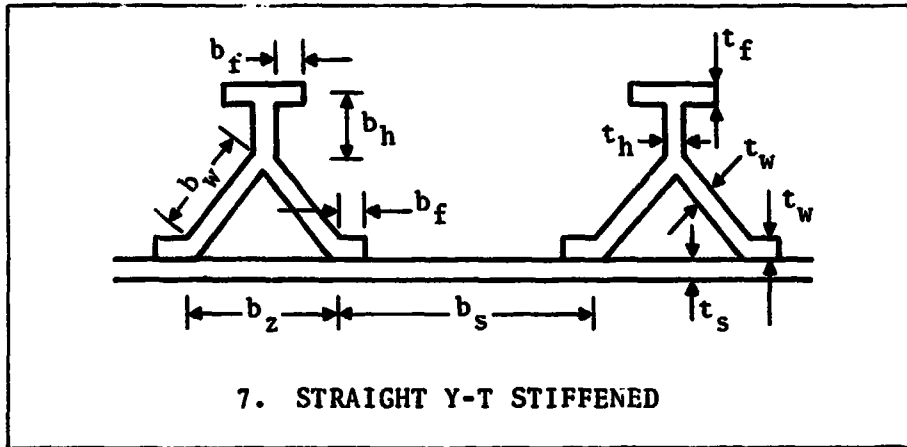

Figure 4.8-4. - Sixteen stiffened panel configurations (continued).

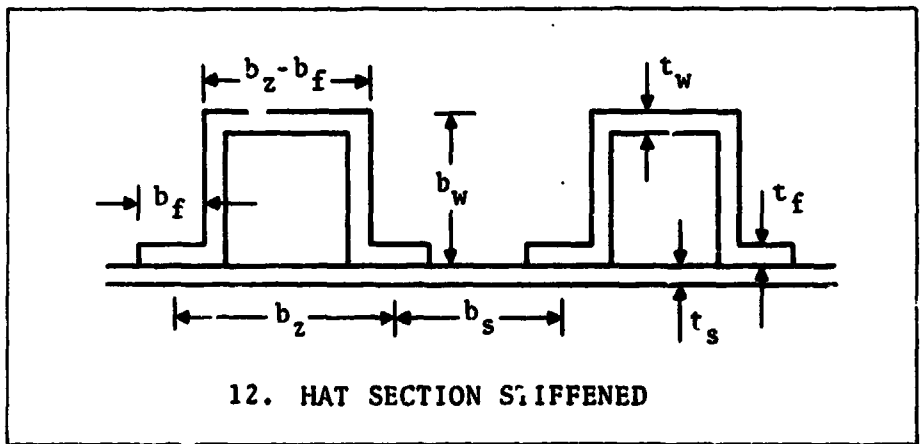
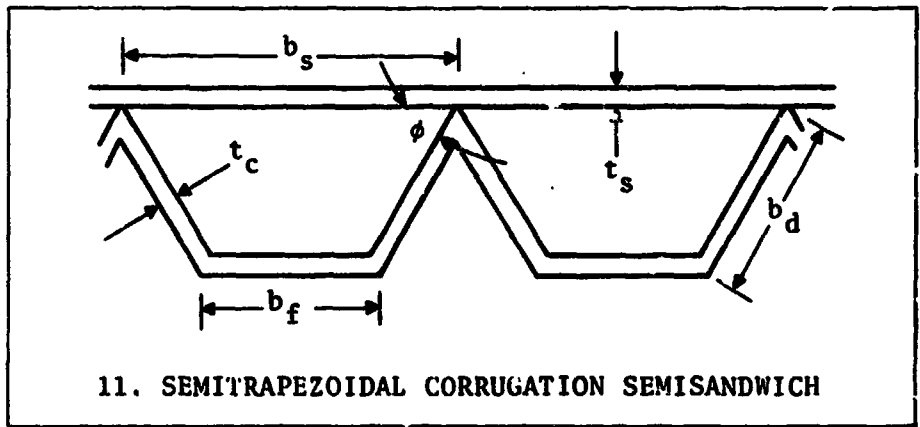
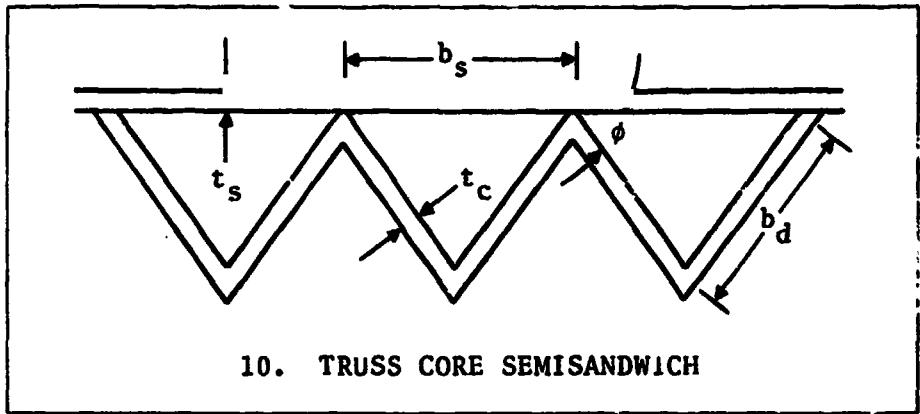
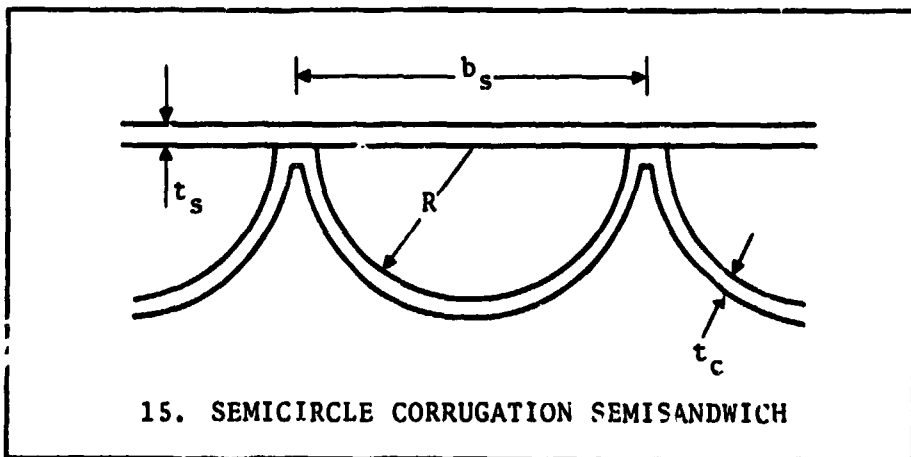
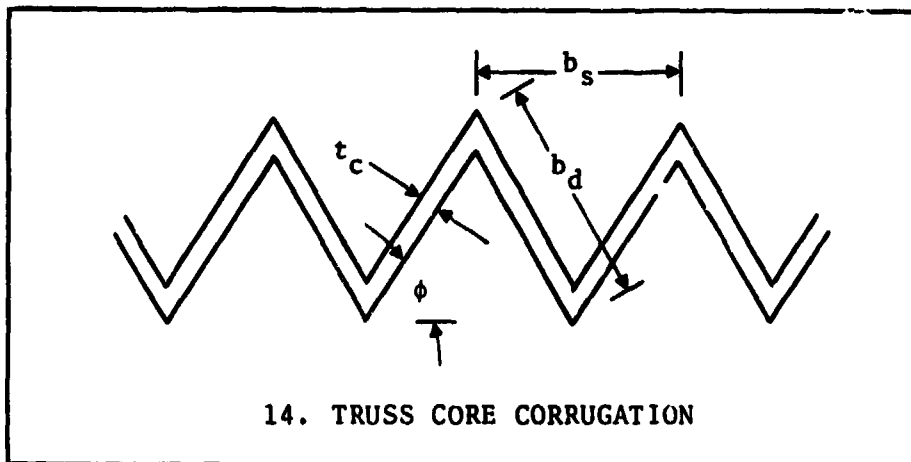
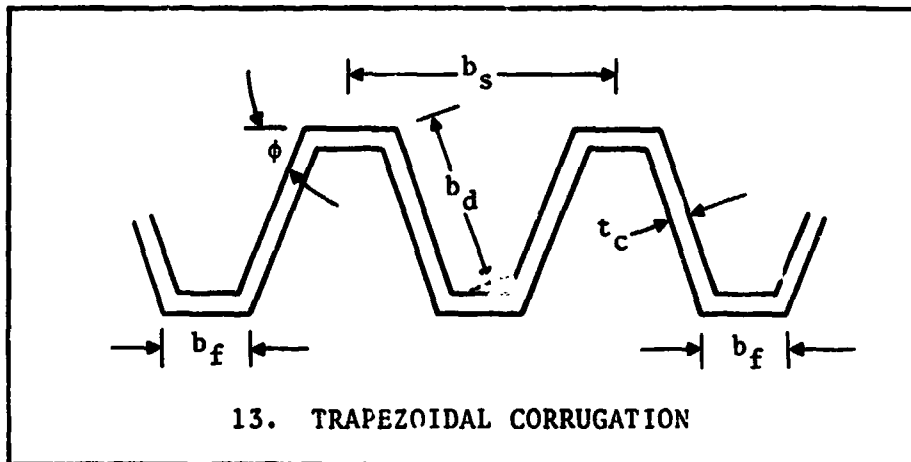

Figure 4.8-4. -- Sixteen stiffened panel configurations (continued).



16. Free Form - The user can describe any form of stiffened panel using this type of input.

Fig 4.8-4. - Sixteen stiffened panel configurations (concluded).

1. INTEGRALLY STIFFENED PANEL

REGION NUMBER	STATION NUMBER	STATION COORDINATES			SECTION PARAMETERS												
		X	Y	Z	b_s	b_w	t_s	t_w									

2. Z-STIFFENED PANEL

REGION NUMBER	STATION NUMBER	STATION COORDINATES			SECTION PARAMETERS												
		X	Y	Z	b_f	b_s	b_w	t_f	t_s	t_w							

3. INTEGRAL Z-STIFFENED PANEL

REGION NUMBER	STATION NUMBER	STATION COORDINATES			SECTION PARAMETERS												
		X	Y	Z	b_f	b_s	b_w	t_f	t_s	t_w							

Figure 4.8-5. - Example of tabular format for panels.

4. INTEGRAL T-STIFFENED PANEL

REGION NUMBER	STATION NUMBER	STATION COORDINATES			SECTION PARAMETERS											
		X	Y	Z	b_f	b_s	b_w	t_f	t_s	t_w						

5. J-STIFFENED PANEL

REGION NUMBER	STATION NUMBER	STATION COORDINATES			SECTION PARAMETERS											
		X	Y	Z	b_f	b_s	b_w	t_f	t_s	t_w						

6. STRAIGHT Y-STIFFENED PANEL

REGION NUMBER	STATION NUMBER	STATION COORDINATES			SECTION PARAMETERS											
		X	Y	Z	b_f	b_h	b_s	b_w	b_z	t_h	t_s	t_w				

4-75

Figure 4.8-5. - Example of tabular format for panels (continued).

7. STRAIGHT Y-T STIFFENED PANEL

REGION NUMBER	STATION NUMBER	STATION COORDINATES			SECTION PARAMETERS									
		X	Y	Z	b_f	b_h	b_s	b_w	b_z	t_f	t_h	t_s	t_w	

8. CURVED Y-T STIFFENED PANEL

REGION NUMBER	STATION NUMBER	STATION COORDINATES			SECTION PARAMETERS									
		X	Y	Z	b_f	b_h	b_s	b_w	b_z	t_f	t_h	t_s	t_w	R

9. TRAPEZOIDAL CORRUGATION SEMISANDWICH PANEL

REGION NUMBER	STATION NUMBER	STATION COORDINATES			SECTION PARAMETERS									
		X	Y	Z	b_d	b_f	b_s	t_c	t_s	ϕ				

Figure 4.8-5. - Example of tabular format for panels (continued).



10. TRUSS CORE SEMISANDWICH PANEL

REGION NUMBER	STATION NUMBER	STATION COORDINATES			SECTION PARAMETERS											
		X	Y	Z	b_d	b_s	t_c	t_s	ϕ							

11. SEMITRAPEZOIDAL CORRUGATION SEMISANDWICH PANEL

REGION NUMBER	STATION NUMBER	STATION COORDINATES			SECTION PARAMETERS											
		X	Y	Z	b_d	b_f	b_s	t_c	t_s	ϕ						

12. HAT SECTION STIFFENED PANEL

REGION NUMBER	STATION NUMBER	STATION COORDINATES			SECTION PARAMETERS											
		X	Y	Z	b_f	b_r	b_w	b_z	t_f	t_s	t_w					

4-77

Figure 4.8-5. - Example of tabular format for panels (continued).

13. TRAPEZOIDAL CORRUGATION PANEL

REGION NUMBER	STATION NUMBER	STATION COORDINATES			SECTION PARAMETERS													
		X	Y	Z	b_d	b_f	b_s	t_c	ϕ									

14. TRUSS CORE CORRUGATION PANEL

REGION NUMBER	STATION NUMBER	STATION COORDINATES			SECTION PARAMETERS													
		X	Y	Z	b_d	b_s	t_c	ϕ										

15. SEMICIRCLE CORRUGATION SEMISANDWICH PANEL

REGION NUMBER	STATION NUMBER	STATION COORDINATES			SECTION PARAMETERS													
		X	Y	Z	b_s	t_c	t_s	R										

Figure 4.8-5. - Example of tabular format for panels (continued).

16. FREE FORM PANEL

REGION NUMBER	STATION NUMBER	STATION COORDINATES			SECTION PARAMETERS*														
		X	Y	Z															

*Maximum of 20 parameters.

Figure 4.8-5. - Example of tabular format for panels (concluded).

REFERENCE AXIS 1

REGION NUMBER	STATION NUMBER	STATION COORDINATES			SECTION PARAMETERS										
		X	Y	Z	b_1	t_1	C_{11}	b_{20}	t_{20}	C_{120}	

REFERENCE AXIS 2

REGION NUMBER	STATION NUMBER	STATION COORDINATES			SECTION PARAMETERS										
		X	Y	Z	b_1	t_1	C_{21}	b_{20}	t_{20}	C_{220}	

4-80

Figure 4.8-6. - Example of beam tabular format.

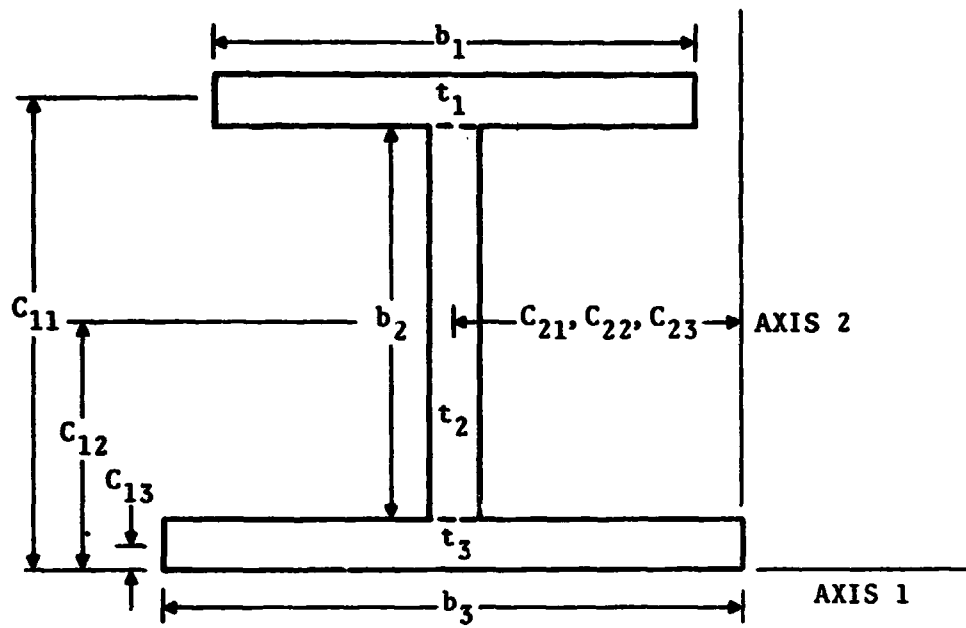

I-SECTION

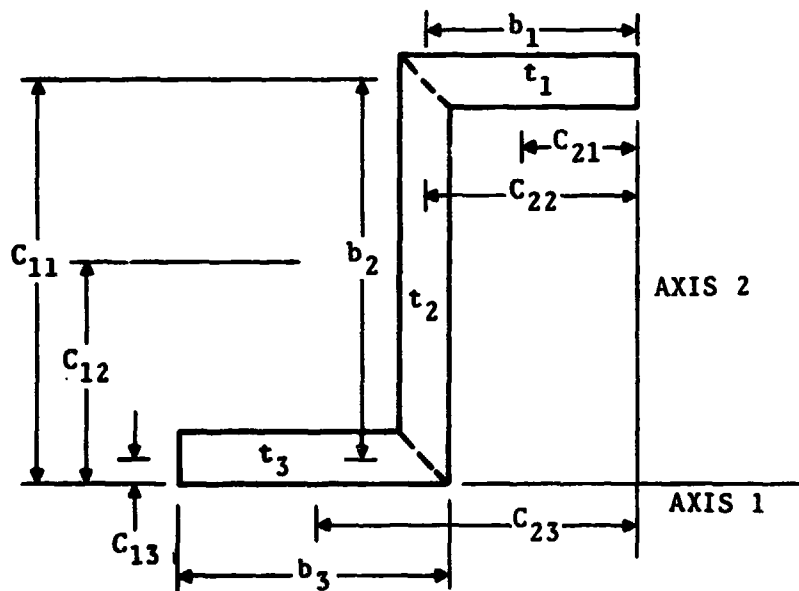

Z-SECTION

Figure 4.8-7. - Typical beam elements.

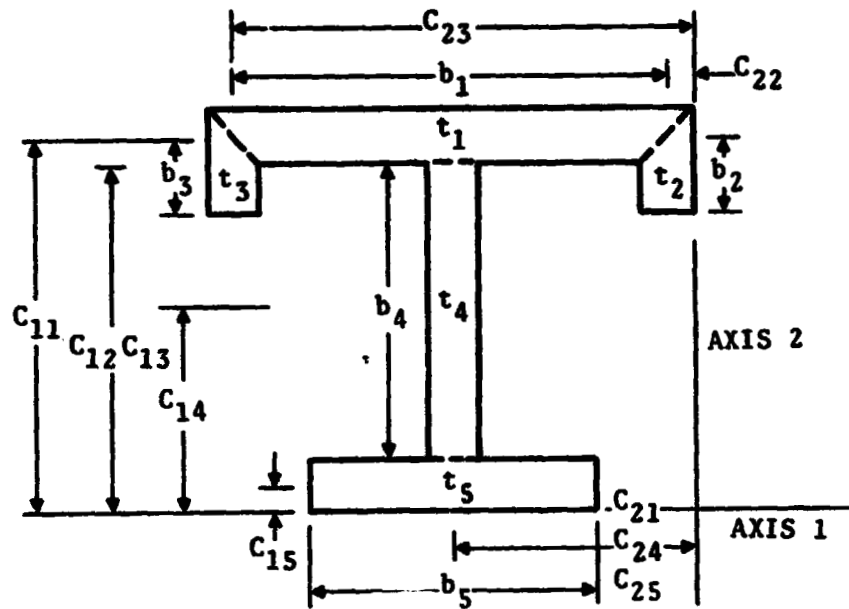

T-SECTION

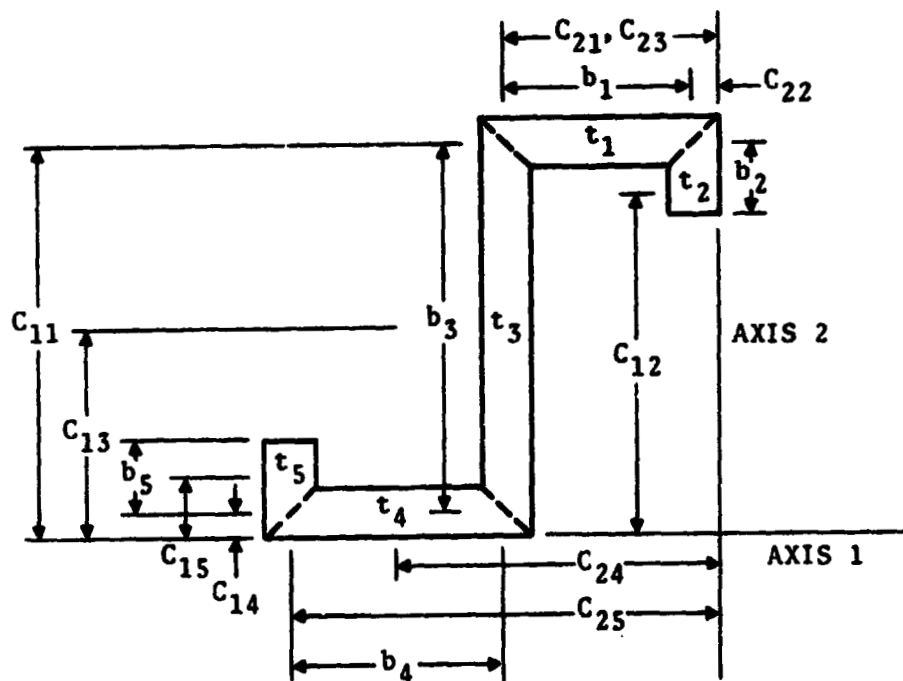

BULBED Z-SECTION

Figure 4.8-7. - Typical beam elements (continued).

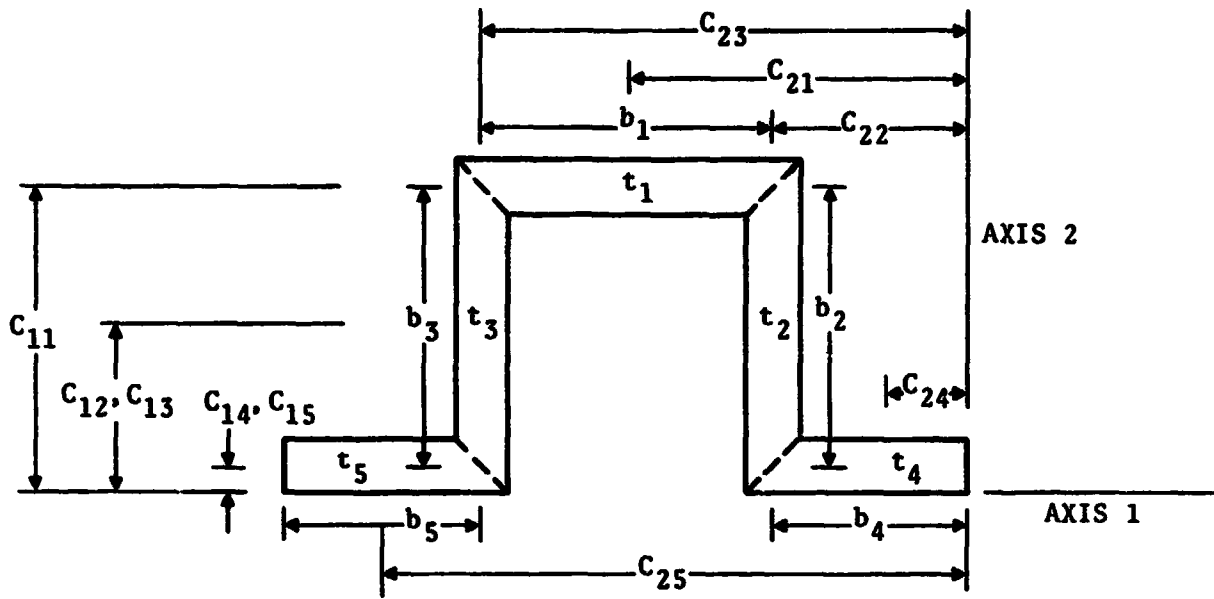

HAT-SECTION

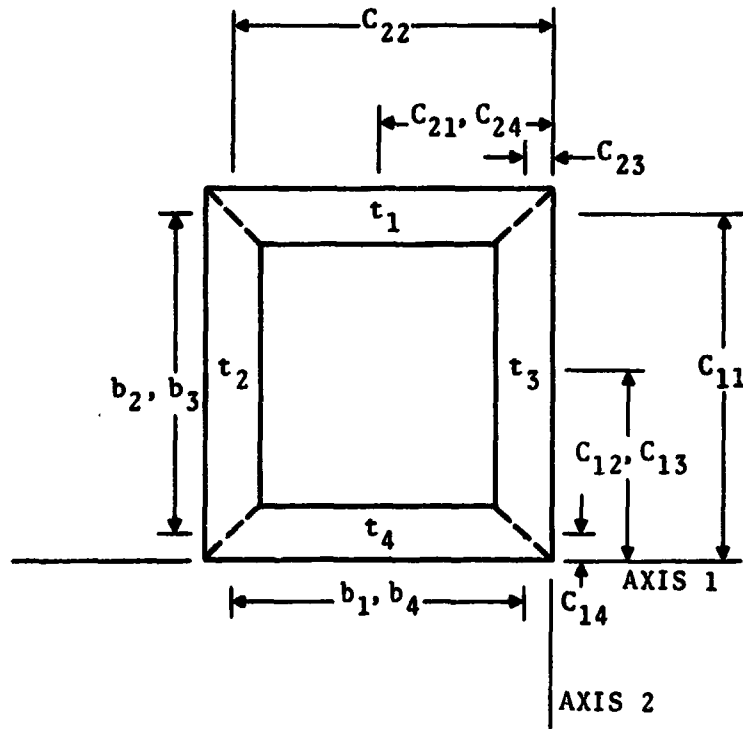

BOX SECTION

Figure 4.8-7. - Typical beam elements (concluded).

TYPE - 4. INTEGRAL T-STIFFENED PANEL
 REGION - NN

STATION NUMBER	COORDINATES			SECTION PARAMETERS					
	X	Y	Z	b_f	b_s	b_w	t_f	t_s	t_w
(I5)	(F9.3)	(F9.3)	(F9.3)	(F9.3)	(F9.3)	(F9.3)	(F9.3)	(F9.3)	(F9.3)

4-84

Figure 4.8-8. - Example of a panel tabular display.

4.9 BOOST FLIGHT CONDITIONS

4.9.1 PURPOSE

This function is needed for evaluating the structural loads on the Space Shuttle launch configuration during boost and recovery phases. Operating in the demand mode from a remote terminal, the user will have the ability to (1) retrieve his input from mass-storage data files, (2) display and modify the input on the console, (3) schedule his job for batch execution, and (4) display the program output in graphical form at the console.

A Batch Flight Conditions File will be created by the Boost Flight Program in order to store the results. This file will be accessed to display the output at the terminal, to produce reports, and for use by other ISAS functions. Figure 4.9-1 is a data flow diagram for Boost Flight Conditions.

4.9.2 INPUT

The input for this function will be obtained from the following sources.

- Basic Data File
- Force Coefficient Data File
- Winds Aloft Data File
- Standard Atmosphere File
- Keyboard input at the terminal

Input for the Boost Flight Program will utilize the FORTRAN defined NAMELIST format. Data from the above sources will be stored in the Input Flight Conditions File and read as input by this function.

4.9.3 PROCESSING

The ISAS system will guide the user in assembling data for the creation of an Input Flight Conditions File. The user will have the capability to enter each input file and select those parameters he wishes to input to the program. Detailed formats and contents for all relevant files can be found in the appendix.

The Basic Data File will contain a reference trajectory, reference dimensions and areas, moments and products of inertia, weight flow rates, and other similar data. Total aerodynamic coefficients will be contained in the Force Coefficient Data File.

The Basic Data File will define the control system parameters, including gains and filter parameters. The Winds Aloft File will contain altitude, wind velocity, and wind direction, indexed by a number. Reference atmospheres for all flight conditions will be contained in the Standard Atmosphere File. The flight conditions will be indexed by altitude and will include pressure, density, temperature, and speed of sound.

Additional data can be input through the keyboard. All of the input can be displayed at the console in tabular form and additions or alterations can be typed from the keyboard. The input may be recorded for report purposes as printouts and/or SC-4060 plots.

These last three files will be included in subroutines of the Boost Flight Program. Thus, unless the Boost Flight Program is revised, the user must input new FORTRAN subroutines in order to vary the built-in parameter values.

The input arrays will be stored in an Input Flight Conditions File. Upon obtaining satisfactory input, the user can call for

execution of the Boost Flight Program; it will execute in the batch mode, reading the Input Flight Conditions File for input.

When the Boost Flight Program has completed execution, output from the program will be stored in the Batch Flight Conditions File and the Boost Plot Data File. The Boost Plot Data File will contain various parameters to be plotted. (Table 4.9-1 lists the available parameters.) There will be three curves to a plot frame. The user may select as many of the curves to be displayed as desired. Hardcopy printouts and SC-4060 plots may also be obtained.

4.9.4 OUTPUT

Output from the function will consist of the following.

- The input data may be displayed in tabular form on the console screen and a hardcopy obtained.
- An Input Flight Conditions File will be created for storing the input for use by the batch program.
- Program output will be stored in the Boost Plot Data File. Graphical displays at the console and SC-4060 plots of the program output can be generated. Table 4.9-1 contains a list of available plots.
- A Batch Flight Conditions File will be created to contain output used by other ISAS functions.

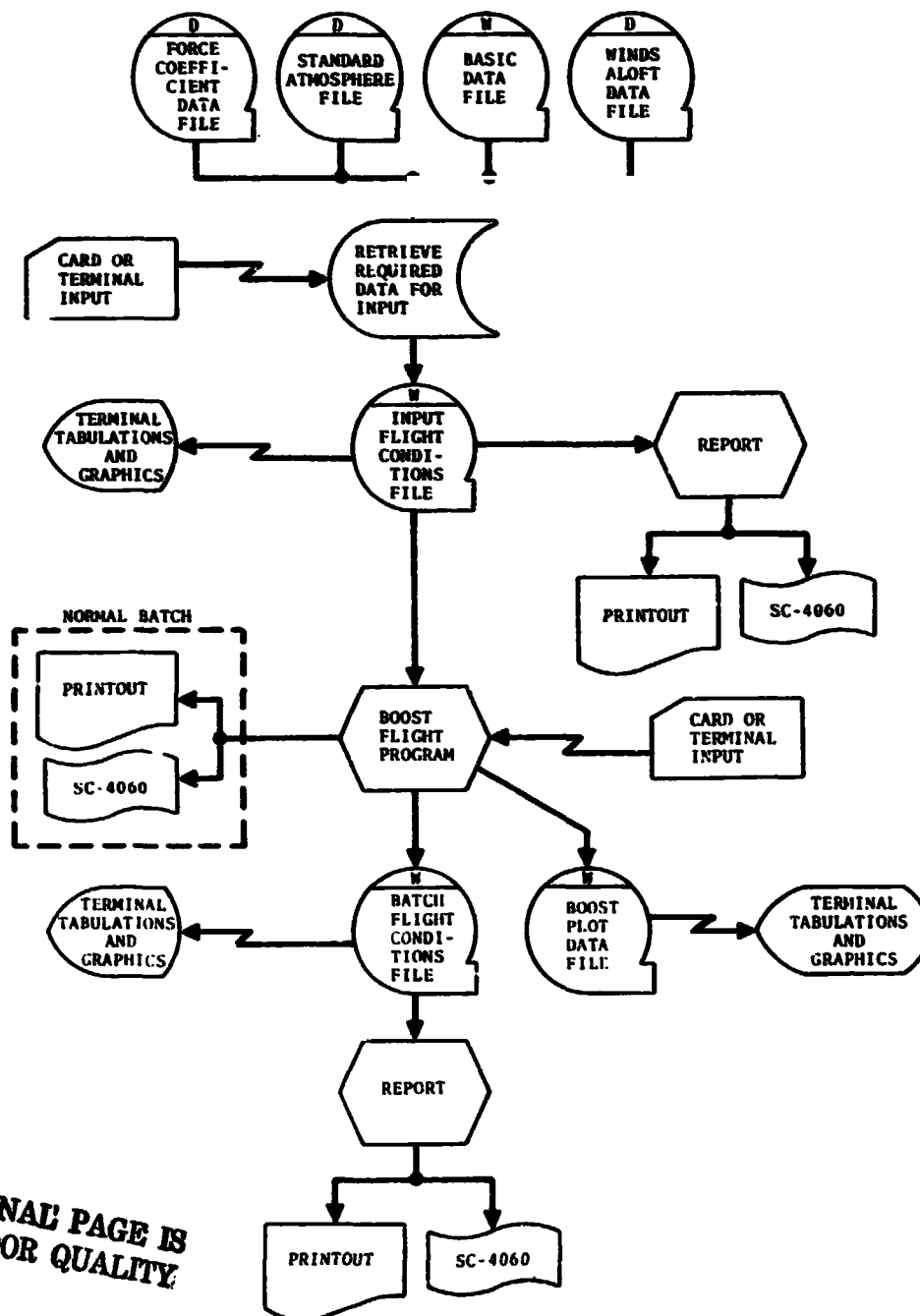

ORIGINAL PAGE IS
OF POOR QUALITY.

Figure 4.9-1. - Data flow diagram for Boost Flight Conditions

TABLE 4.9-1. -- AVAILABLE PLOTS FOR BOOST FLIGHT
CONDITIONS FUNCTION

Frame Number	Variable	Description	Units
1	QBAR	Dynamic pressure	lb/ft ²
	ALT	Altitude	ft
	AMACH	Mach number	
2	VWY	Wind velocity in the platform Y-direction	in./sec
	ALPHAY	Booster body yaw angle of attack	deg
	QBAR* ALPHAY	Dynamic pressure multiplied by booster body yaw angle of attack	deg-lb/ft ²
3	VRELM	Vehicle relative velocity magnitude	in./sec
	THRUST	Booster thrust magnitude	lb/10 ⁶
	WEIGHT	Vehicle weight	lb/10 ⁶
4	VWZ	Wind velocity in the platform Z-direction	in./sec
	ALPHAP	Booster body pitch angle of attack	deg
	QBAR* ALPHAP	Dynamic pressure multiplied by pitch angle	deg-lb/ft ²
5	XDD	X-body acceleration	g
	YDD	Y-body acceleration	g
	ZDD	Z-body acceleration	g
6	PHIDD	X-platform axis, rotational acceleration	rad/sec ²
	THETADD	Y-platform axis, rotational acceleration	rad/sec ²
	PSIDD	Z-platform axis, rotational acceleration	rad/sec ²

TABLE 4.9-1. - AVAILABLE PLOTS FOR BOOST FLIGHT
CONDITIONS FUNCTION - Concluded

Frame Number	Variable	Description	Units
7	PHI	Roll angle	deg
	THETA	Pitch angle	deg
	PSI	Yaw angle	deg
8	PHIC	Commanded roll angle	deg
	THETAC	Commanded pitch angle	deg
	PSIC	Commanded yaw angle	deg
9	Y LOAD	Total lateral reaction on aft fittings	lb
	FORE Y LOAD	Lateral reaction on foreward fitting	lb
	X FIT LOAD	Total longitudinal fitting reaction	lb
10	LEFT Z LOAD	Vertical reaction on left aft fitting	lb
	RT Z LOAD	Vertical reaction on right aft fitting	lb
	FORE Z LOAD	Vertical reaction on forward fitting	lb
11	THRUST	Total thrust for each engine (1 to 5)	10^6 lb
⋮	BETAY	Engine gimbal angle about Y axis	deg
15	BETAZ	Engine gimbal angle about Z axis	deg
16	QBAR	Dynamic pressure vs. Mach number	lb/ft ²
	ALPHAP	Pitch vs. Mach number	deg
	QBAR*ALPHAP	QBAR*ALPHAP vs. Mach number	deg-lb/ft ²
17	ALTITUDE	Altitude vs. Mach number	ft
	ALPHAY	Yaw angle-of-attack vs. Mach number	deg
	QBAR*ALPHAY	Dynamic pressure multiplied by yaw angle-of-attack vs. Mach number	deg-lb/ft ²

4.10 DYNAMIC LOADS

The requirement to provide support in this area was deleted by the Structures Branch (ES2). Figure 4.10-1 is a data flow diagram of the Dynamic Loads function.

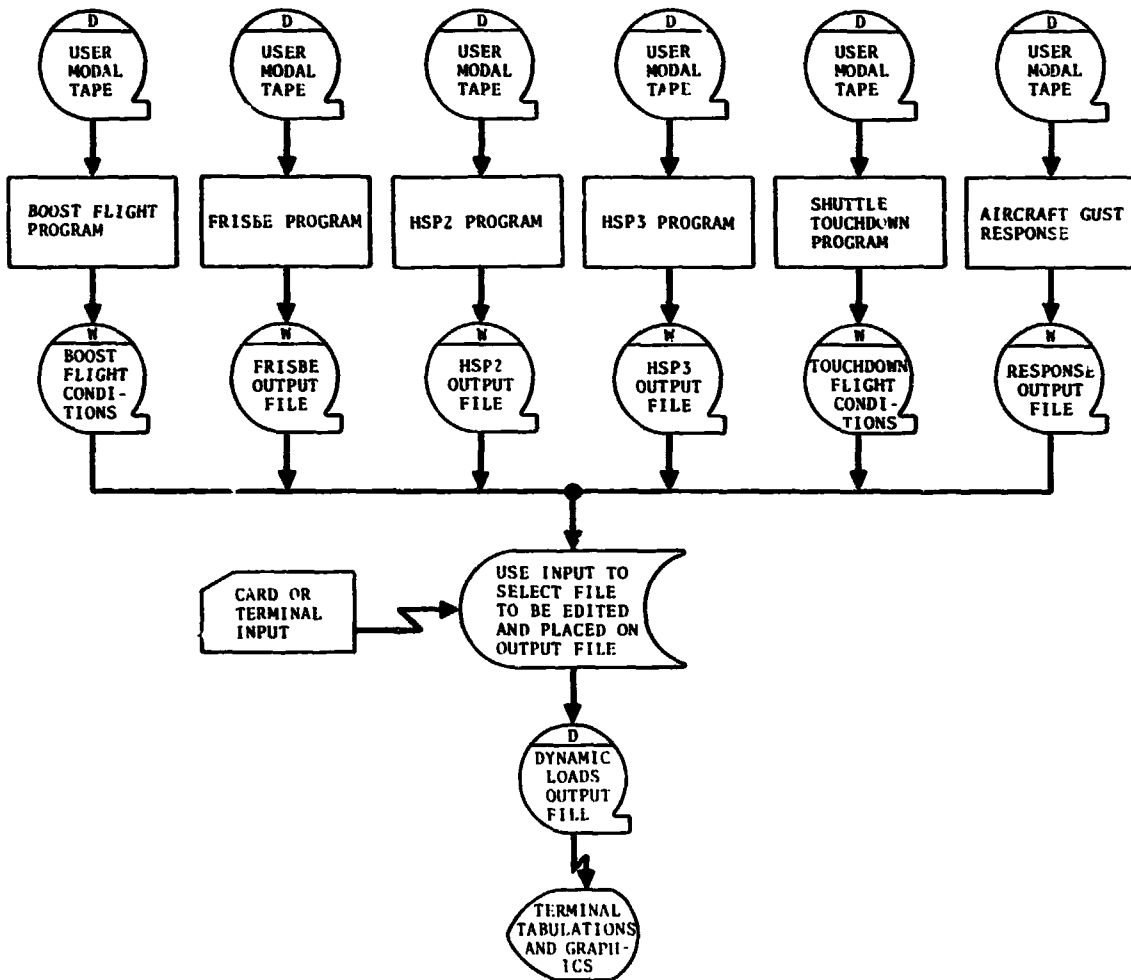

Figure 4.10-1. - Data flow diagram for Dynamic Loads.

ORIGINAL PAGE IS
OF POOR QUALITY

4.11 ELEMENT PROPERTY FILE GENERATOR

4.11.1 PURPOSE

This function will generate the Element Property File, which will provide section properties for each of the elements defined in the User Model File. The Element Property File can then serve as input for other programs in the ISAS system. Figure 4.11-1 is a data flow diagram for this function.

4.11.2 INPUT

The input will consist of the User Model File, Section Properties and Allowables File, and other data provided by the user.

4.11.3 PROCESSING

The demand processing function will use visual displays to lead the user through the procedures. The first input will be the file names of the User Model File and the Section Properties and Allowables File. These two files will provide input data for the processing. The User Model File will contain the type of element, element number, and grid point numbers of the element; the Section Properties and Allowables File will provide section properties information referenced by grid point in each region.

After the file names are verified, the processing function should generate a table of material properties for the elements defined. The function should search the User Model File and Section Properties and Allowables file for corresponding grid point numbers within each region and generate a table for the element number corresponding to the grid point number. The user should be provided with a menu to select the properties to be included in the Element Property File. The properties will be similar to those of the Section Properties and Allowables File and include width, thickness, area, and moments of inertia. The user can

choose several properties or all properties, depending on the anticipated use of the Element Property File.

The user will be able to edit the file after it is generated; i.e., to override the properties by inputting new data values that might be required for design changes. The user will then be requested to input a file name for the Element Property File. The user will be able to display the file in a tabular data form showing element number, element type, and section properties. The data on this file should be referenced by element number. A sample of the format is as follows:

Element Number	Element Type	Section Properties					
	Rod	A	J				
	Beam	A	I1	I2	J	K1	K2

where

A - cross sectional area

J - Torsional Constant

I1 - moment of inertia about first plane

I2 - moment of inertia about second plane

K1 - shear area factor about first plane

K2 - shear area factor about second plane

4.11.4 OUTPUT

The Element Property File will be output. This file is defined in the appendix.

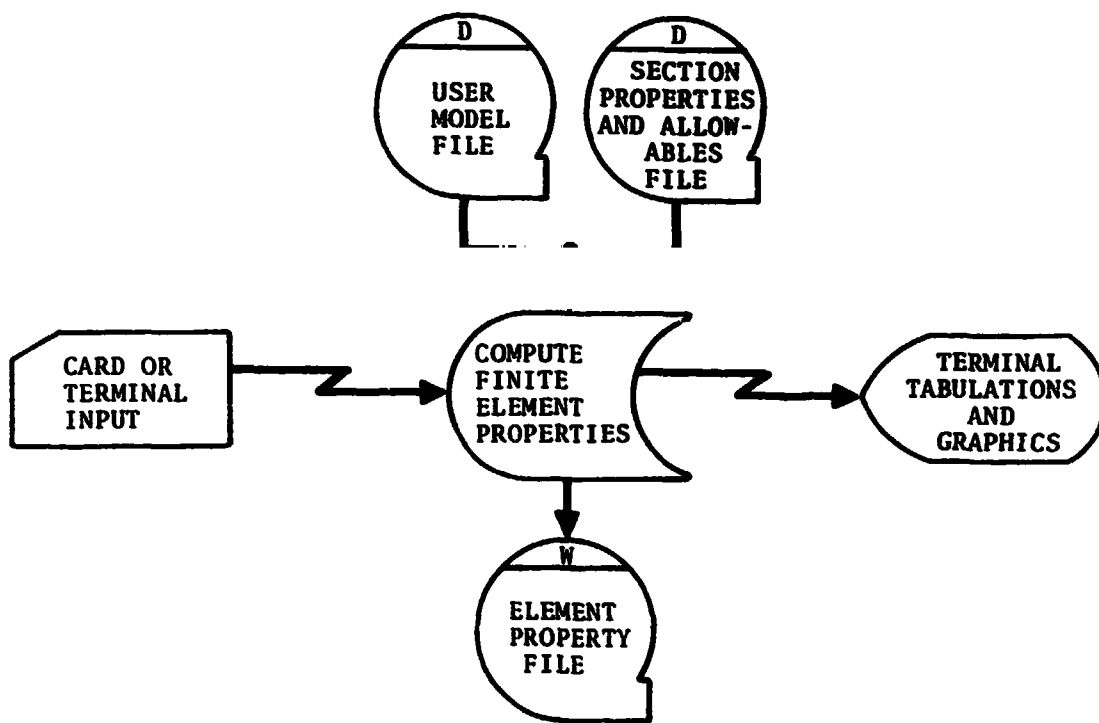

Figure 4.11-1. -- Data flow diagram for Element Property File Generator.

4.12 FATIGUE ASSESSMENT

4.12.1 PURPOSE

This function will provide a method for calculating the damage to structures subjected to a wide range of loading conditions. This analysis will be performed on a wide range of structural materials. The damage will be used in computing the expected fatigue life of the material. Graphical displays will be presented showing the cycles to failure for different stress levels. A data flow diagram for Fatigue Assessment is shown in figure 4.12-1.

4.12.2 INPUT

The input data required by this function will be obtained from the NASTRAN Sorted Data File and the Fatigue Input Data File. Descriptions of these files can be found in the appendix of this document. The user will be able to supplement or modify any of the data obtained from these files by the use of the remote terminal.

At the remote terminal, the user will also input any control information needed by this function. This information will include the location on the vehicle at which stresses are to be analyzed, the type of load to be used in the analysis, the type of element, and the type of material.

4.12.3 PROCESSING

Three subfunctions will be used in the processing to be performed by this function. These subfunctions are: Form Stress Time History and Stress Ratio, Compute Accumulative Damage, and Compute Equivalent Damage Spectra. Each of these subfunctions will create a data file which will be used in the succeeding subfunction. Therefore, in the normal demand mode of operation, the user can terminate his job after any subfunction is completed and later begin his job at the beginning of the next subfunction.

4.12.3.1 Form Stress Time History and Stress Ratio
(Subfunction 1)

This subfunction will create the Stress Data File using the NASTRAN Sorted Data File as input. The NASTRAN Sorted Data File will contain load spectra exceedance curves which will be identified by location on the vehicle; load type such as shear X, moment Y, accelerations, or pressures; type of flight; and flight time. This subfunction will create one load spectrum for each location on the vehicle at which fatigue analysis is to be performed. These spectra will include the data for one entire flight.

The user will select from the NASTRAN Sorted Data File (or input at the terminal) the flight identification, the location on the vehicle at which the analysis is to be performed, and the type load to be used to build this spectrum. The subfunction will retrieve all spectra which satisfy these conditions. The spectra will be for all flight times for the specified flight. For each spectrum, the maximum and minimum load at exceedance values $8 \times 10^{N-1}$, $4.5 \times 10^{N-1}$, and $2 \times 10^{N-1}$ will be saved. A value of -3 will be the lower boundary on N and the upper boundary will have no limit. It will be determined by the data available on the file. The data values at each exceedance value will be considered a load step. For each load step, the cycles per flight will be computed using the following table.

<u>Exceedance Value</u>	<u>Cycles per Flight</u>
$8 \times 10^{N-1}$	$4 \times 10^{N-1}$
$4.5 \times 10^{N-1}$	$3 \times 10^{N-1}$
$2 \times 10^{N-1}$	$2 \times 10^{N-1}$

Also for each load step, the load/stress ratio will be retrieved from the NASTRAN Sorted Data File or will be input at the terminal. The load step numbers, maximum and minimum loads, cycles

per flight, and load/stress ratios will be output on the Stress Data File. The user will then specify the conditions for the next spectrum. This process will be repeated until all desired spectra are output on the Stress Data File.

Output from this subfunction will consist of the Stress Data File, tabulations of the data output on this file, and graphical displays of any of the spectra input from the NASTRAN Sorted Data File.

4.12.3.2 Compute Accumulative Damage (Subfunction 2)

This subfunction will be used to compute the accumulative damage of mechanical or acoustic fatigue for various materials at different locations on the vehicle. Data will be input from the Stress Data File and the Fatigue Input Data File, and the results from the mechanical fatigue analysis will be output on the Fatigue Output Data File. This subfunction will be divided into two parts, mechanical fatigue analysis and acoustic fatigue analysis. The mechanical fatigue is discussed first.

Input to the mechanical fatigue program will consist of load spectra data from the Stress Data File. These data will be identified by flight identification, location on the vehicle on which the analysis is to be performed, and type of load. The user will have the option of processing the entire Stress Data File or selecting which spectra are to be processed. The user may modify the spectra retrieved from the above file or input a spectrum if it is not on the file. After a load spectrum has been input, the load/stress ratio will be used to convert the maximum and minimum loads at each load step to stresses. Next, the stress ratio (R) of the minimum stress to the maximum stress at each load step will be computed. The user will then input the identification of the material to be analyzed. The Fatigue Input Data File will be searched for the stress versus cycles-to-failure (S-N) curve data

for this material. The user will have the option of modifying the S-N data or inputting them if they are not available on the data file. Graphical displays of this S-N data will be required.

For each value of maximum stress and corresponding R, the cycles to failure will be retrieved from the S-N curve data. The incremental damage for each load step will be computed by dividing the cycles per flight (retrieved from the Stress Data File) by the cycles to failure. The accumulative damage will be determined by summing the incremental damage. The life expectancy will be the reciprocal of the accumulative damage. These results will be tabulated and output on the Fatigue Output Data File. The user can then input another type of material to be analyzed using the current load spectrum, or he can request another load spectrum to be input from the Stress Data File. Processing will be terminated when all load spectra and all types of material requested have been processed.

The acoustic fatigue program will receive its input from the Fatigue Input Data File and from the remote terminal. The following information will be input at the terminal.

1. Material identification – This information will include material type, alloy, temper, notch factor (K_T), modulus of elasticity, Poisson's ratio, ultimate tensile stress, and R-factor.
2. Type of element – Analysis will be performed for either a plate or a beam. For a beam, the user will input the length of the beam and the moment of inertia. For a plate, input will consist of the length, width, and thickness.
3. Density factor – For a beam the weight will be input; for a plate the density will be input.
4. Boundary conditions – The boundary conditions for both the beam and the plate will be simple support, free end, or fixed

end. For a beam, the user will input the boundary conditions for each end. For a plate, each of the four sides will be identified.

5. Number of factors - The user will input the number and name of the factors, other than liftoff and aerodynamic noise, which are to be used in the analysis.
6. Time - The user will input time in seconds for each factor.

After the above data are input, the fundamental frequency (f_n) of the element will be computed. For a beam, the formula is:

$$f_n = C \sqrt{\frac{386 EI}{WL^4}}$$

where

C - constant which is retrieved from the Fatigue Input Data File by length of beam and boundary conditions

E - modulus of elasticity

I - moment of inertia

W - density factor per length

L - length

For a plate, the formula is:

$$f_n = \sqrt{\frac{\pi^2 DK}{4a^4 \rho N_{BC}}}$$

where

D - $Et^3/12(1 - \nu^2)$

t - thickness

- μ - Poisson's ratio
- a - length
- ρ - (density factor \times t)/386
- N_{BC}, K - constants retrieved from the Fatigue Input Data File and identified by boundary conditions (length and width)

Next, the sound pressure level (SPL) using one-third octave band frequencies will be determined for each of the factors being considered. Data for the liftoff and aerodynamic noise factors will be stored on the Fatigue Input Data File. Data for the other factors can also be stored on this file. The user will have the option of retrieving these data from the file or entering the data at the terminal.

The SPL using one-third octave band frequencies will then be used in computing the SPL per hertz for each factor as follows.

$$SPL/Hz = SPL\ 1/3 - 10 \log_{10} (\sqrt{2}/6 f_n)$$

Next, the spectral density, $G_p(f_n)$, will be computed for each factor using the equation:

$$G_p(f_n) = (P_{ref}^2) \text{ antilog } \frac{SPL/Hz}{10}$$

where

$$P_{ref} = 2.9 \times 10^{-9} \text{ lb/in.}^2 \text{ or } (.0002) \frac{\text{dynes}}{\text{cm}^2}$$

The static pressure (σ_o) will be determined next. A table of equations will be used to compute the static pressure. The equation to be used will be determined by the type of element being

analyzed and the boundary conditions of the element. The root mean square stress (σ_{rms}) will be computed for each factor using the formula:

$$\sigma_{rms} = \sigma_o \left[\frac{\pi}{4\delta} f_n (G_p(f_n)) \right]^{1/2}$$

where

δ is the damping ratio and is input by the user at the terminal.

The percent root mean square (rms) will be determined for each factor by dividing the σ_{rms} by the ultimate tensile stress. The cycles to failure for each factor will be determined from the percent rms curve data. Several methods can be used to obtain these data. First, the Fatigue Input Data File will be searched using the material identification as the retrieval parameter. If the data are not on this file, the user may input the data. A third method will be to compute the percent rms curve data from the S-N data. The S-N data will be retrieved from the Fatigue Input Data File or will be input at the terminal. After the S-N data have been input, the cycles to failure (N_R) will be computed for each σ_{rms} using the equation:

$$N_R = \frac{1}{\int_A^B \frac{P(x) dx}{N_{\sigma x}}}$$

where

$$P(x) = x e^{-(x^2/2)}$$

$$c = 2.71828$$

$$x = \frac{\sigma_x}{\sqrt{\sigma_R^2}}$$

σ_x - stress level on the S-N curve

$$\sqrt{\sigma_R^{-2} - (\sigma_{rms})^2}$$

N_{σ_x} - cycles to failure of σ_x

A, B - integration limits input by the user at the terminal

The cycles per flight (n) will be computed for each factor by multiplying the time by the fundamental frequency (f_n). The incremental damage will then be computed for each factor by dividing n by N_R . Finally the total damage for acoustic fatigue will be determined by summing the incremental damage of each factor.

Output will consist of a tabulation of the total damage. The user should have the capability to update the Fatigue Input Data File with the new S-N data or SPL data input at the terminal and with the generated percent rms curve data.

4.12.3.3 Compute Equivalent Damage Spectra (Subfunction 3)

This subfunction will be used to compute equivalent damage spectra from data contained on the Fatigue Output Data File and output these data on the Fatigue Spectral Data File. The user will select the location on the vehicle at which the equivalent damage spectrum is to be calculated. The user will also identify the type of material for which the equivalent damage spectrum is to be calculated. The Fatigue Output Data File will be searched for all spectra which satisfy the above conditions.

Each spectrum will be for a given flight. For each of these spectra, the cycles to failure for the maximum and minimum percent stress will be retrieved. The total accumulated damage will also be retrieved. The equivalent applied cycles to failure will be computed by multiplying the cycles to failure by the total

accumulated damage. The maximum and minimum percent stress will be converted to actual stress by multiplying the percent stress times the ultimate tensile stress (FTU) and dividing by 100. The actual maximum and minimum stress and the equivalent applied cycles to failure will be tabulated and output on the Fatigue Spectral Data File. After all flights for the given material and location on the vehicle are processed, the next material and location on the vehicle will be input and the process repeated.

4.12.4 OUTPUT

This function will output the following data files which are described in the appendix of this document.

- Stress Data File
- Fatigue Output Data File
- Fatigue Spectral Data File

This function will also update the Fatigue Input Data File.

Tabulations will be required of the data calculated in each of the subfunctions. Graphical displays are required for the load spectra data from the NASTRAN Sorted Data File, and the S-N data and percent rms data from the Fatigue Input Data File.

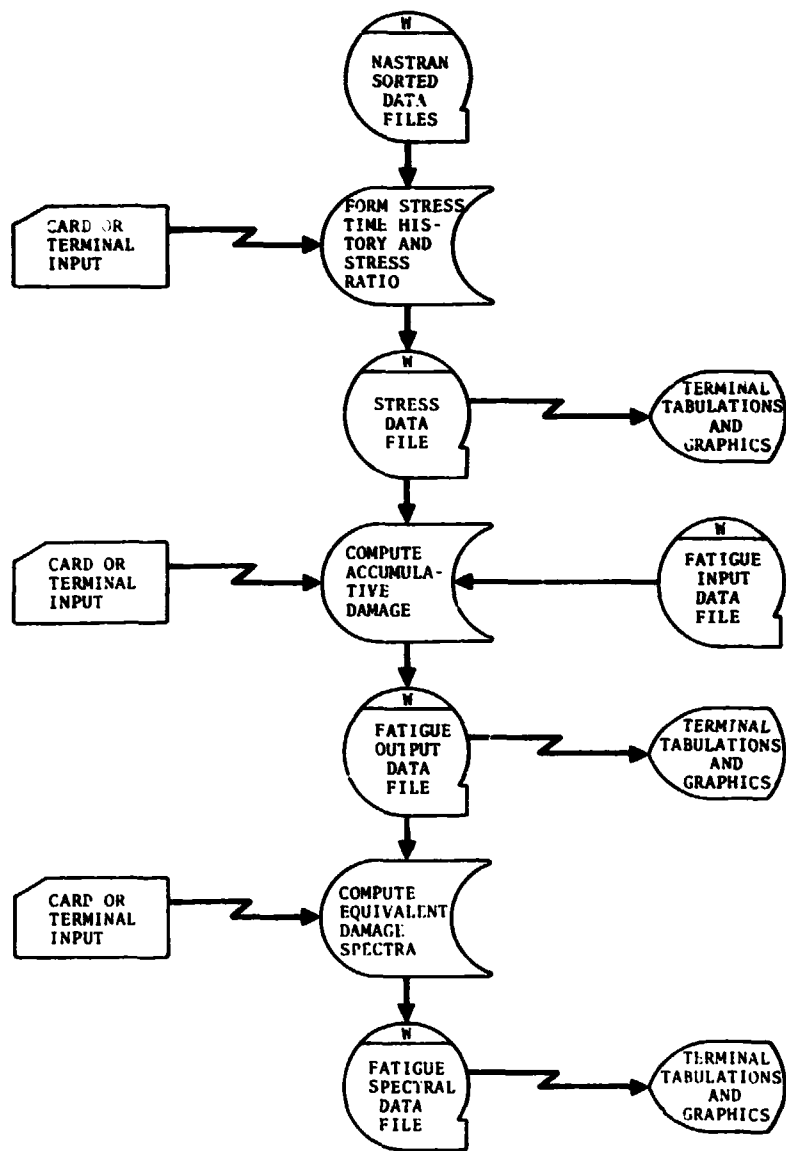

**ORIGINAL PAGE IS
OF POOR QUALITY**

Figure 4.12-1. - Data flow diagram for Fatigue Assessment.

4.13 FLIGHT CONDITIONS MERGE

4.13.1 PURPOSE

This function should provide the capability to merge flight conditions data from multi-input files into a single output file. Figure 4.13-1 is a data flow diagram of the Flight Conditions Merge function.

4.13.2 INPUT

The input to this function will be one or more ISAS Flight Conditions Files and some control information supplied by the user at the demand terminal. This control information will be the file identification and the times used to select the required data.

4.13.3 PROGRAM

In this function, the user should be allowed to merge flight condition data from several ISAS Flight Conditions Files onto a single Merged Flight Conditions File. There should be no limitation on the number of input files or the number of time points transferred. The handling of the output file must allow for additional data to be placed on an already existing Merged Flight Conditions File or to be used to create a new output file.

A restriction will exist that only flight conditions files generated by the same program will be merged; that is, the first two words of the title block must be identical to the same words of the first file used to start this function.

After an input file has been assigned, the program should display the start and stop times. Upon a user command, the times for each data block should be displayed. With this information, the user will be able to select the data blocks to be placed on the

output file. Two methods will be used to select the data to be transferred.

1. Individually selected time point data transfer
2. Range of time point data transfer

In the first method, the user must input a value for time, and the data for that time point will be transferred. The second method will require that all data between the two time values (including both end points) be transferred. It is required that the capability exist to use either one or both of the data selection methods in the same pass through the function. None of the data transferred is to be modified either by the program or by the user. The entire Header Information Block from each input file must be copied onto the output file if any data blocks are transferred. This block should be modified to reflect only those times transferred.

In the file to be output by this function, the individual time points may not be unique. Therefore, another method is required to identify the time blocks. Each block should be assigned a two-word identification in addition to the existing information. The first word will be an alphanumeric word (maximum six of characters) supplied by the user. This word must be used for each data block on the output file. The first data block will be assigned number 1, and the n th block will be n . The header block of the output file should correlate the two identification words with the time of the data block. The file must not have any duplication of the two identification words. The third word of the title of the output file must contain the Fielddata word "MERGED".

4.13.4 OUTPUT

The output of this function will consist of only two items. The first will be a display of times from the input files. The second output will be the Merged Flight Conditions File. A description of this file can be found in the appendix.

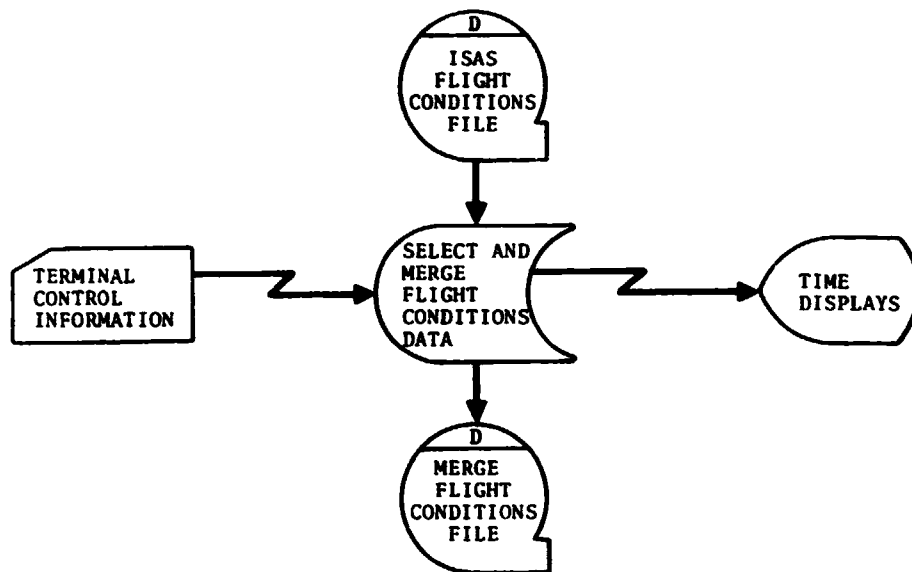

Figure 4.13-1. - Data flow diagram for Flight Conditions Merge.

4.14 FLIGHT CONDITIONS FILE REDUCTION

4.14.1 PURPOSE

The Flight Conditions File Reduction function will allow the user to select important time points from an Input Flight Conditions File and save only the time selected points on a smaller file, thus saving mass storage for more important data. Figure 4.14-1 is a data flow diagram of the Flight Conditions File Reduction function.

4.14.2 INPUT

The input to this function will consist of an ISAS Flight Conditions File and appropriate instructions as to what data are to be transferred to the Batch Flight Conditions File (see file descriptions in the appendix).

4.14.3 PROCESSING

This function will only transfer the data from one file to another. No modification, except in the file identification parameter block, will be made to the data. The change to the title in the parameter block will consist of adding the word "REDUCE" as the third word of the 24-word title block. The other data which will be changed are the start and stop time parameters. After all data have been selected, the program must scan the times and determine the proper values for the new start and stop times.

The function should display the start and stop times from the input data file. The individual times from the data blocks should also be displayed upon user command.

Two methods will be used to select the data to be transferred.

1. Individually selected time point data transfer
2. Range of time point data transfer

For the first method, the user will input values for time and tolerance, and the data for that time point will be transferred to the output file. The user should then be allowed to select the next time or to use method 2.

The second method requires that all data between the two time values input (including both the end points) be transferred. It is required that the capability exist to use either one or both of the data selection methods in the same pass through the function. There should be no restriction on the order in which the user selects times.

After the user has completed all data selection, the function should perform the following actions:

- Order the selected data to assure that the time values are in ascending order
- Delete any duplicate time points (first one saved; any others deleted)
- End the file with a block of words which contains six alphanumeric 9's ("999999").

Data from only one input file will be placed on the output file. This function will not merge data from two or more files.

4.14.4 OUTPUT

The primary output from this function will be a standard Batch Flight Conditions File (see description in the appendix) containing the selected data. The only other output will be displays of the start time, stop time, and individual times from the data blocks. There will be no tabular or graphical displays of any other data.

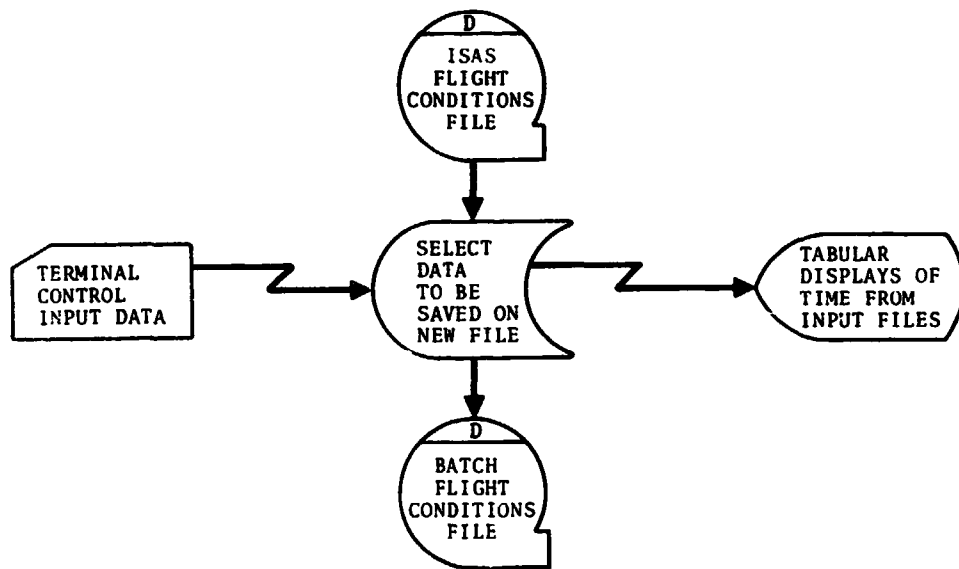

Figure 4.i4-1. - Data flow diagram for Flight Conditions File Reduction.

ORIGINAL PAGE IS
OF POOR QUALITY

4.15 INTERNAL LOADS AND DYNAMIC CHARACTERISTICS

4.15.1 PURPOSE

This function of ISAS will provide the user with the capability to prepare a data file (Runstream Input File) which can be input to the analysis programs listed below. Figure 4.15-1 is a data flow diagram of the Internal Loads and Dynamic Characteristics function.

- NASA Structural Analysis (NASTRAN)
- Automated Structural Optimization (ASOP)
- Analysis of Aerospace Structures by the Displacement Method (Air Force Program)
- Structural Analysis Program (SAP)*
- Acoustic Fatigue Analysis*
- Thermal Protection System (TPS)*

The ability of the Analysis of Aerospace Structures by the Displacement Method program to use the Runstream Input File will be dependent upon modifications which will allow the input of NASTRAN type card images.

4.15.2 NASA STRUCTURAL ANALYSIS SYSTEM (NASTRAN)

4.15.2.1 Input

The type of data to be input to this function will be dependent upon the analysis which is to be performed. Data can be retrieved from any combination of the following seven data files. (See the appendix for file formats.)

*The requirement to prepare a Runstream Input File for the Structural Analysis Program (SAP), Acoustic Fatigue Program, and the Thermal Protection System (TPS) has been removed by NASA (ES2).

- User Model File
- Element Property File
- Model Material File
- Model Temperature File
- Model Weight File
- Model Loads File
- Structural Allowable Data File

Using the manual data entry capability of the remote terminal, the user may supplement or modify any of the data obtained from the above files.

4.15.2.2 Processing

Card images will be prepared for different files used in processing. In describing the card images, some names are flagged using the symbols listed below. These flags give information as to the source of that data.

- + - entry shown is actual entry in the field
- ° - information retrieved from the Model Weight File
- x - information retrieved from the Model Temperature File
- * - information retrieved from User Model File
- ± - information constructed by the software of this function
- @ - information obtained from the Element Property File
- \$ - information obtained from the Model Material File

4.15.2.2.1 Grid Points Description

The entire User Model File will be read in order to obtain all grid points and element descriptions which define the model. For each grid point used in the model, a GRID card image should be constructed in the following format.

1-8	9-16	17-24	25-32	33-40	41-48	49-56	57-64	65-72	73-80
GRID ⁺	ID*	CP*	X1*	Y1*	Z1*	CD	PS		

where

- GRID⁺ - card identification
- ID* - grid point identification number
- CP* - coordinate system (blank unless changed manually)
- X1*, Y1*, Z1* - coordinates of the grid point (real number)
- CD - blank unless changed manually
- PS - blank unless changed manually

4.15.2.2.2 Element Description

Using the property identification number of each element as an index, the program will read the Element Property File and obtain property descriptions of each element. From the information that is obtained from the User Model and Element Property Files, the function can construct element description cards and element property description cards. The type of element will determine which one of the 15 element description cards will be used. If an element property description card is also to be constructed, then the type of card will also be determined by the element type. On the following pages is a description of the 15 element description cards and their related property description cards. Only those data fields in which the program will place data are discussed. The user will have the ability to add data for any remaining data fields using the edit capability of the remote terminal. A detailed description of all NASTRAN cards may be found in the *NASTRAN User's Manual* (NASA SP-222 version 01).

4.15.2.2.2.1 SIMPLE BEAM ELEMENT. The element description card will be constructed as follows.

1-8	9-16	17-24	25-32	33-40	41-48	49-56	57-64	65-72	73-80
CBAR ⁺	EID*	PID [‡]	GA*	GB*	GO*	X	X	F [‡]	abc [‡]
c [‡]	PA	PB	Z1A	Z2A	Z3A	Z1B	Z2B	Z3B	X

where

- CBAR⁺ - card identification for simple beam element description
- EID* - element identification number
- PID[‡] - identification number of property description card (PBAR) for this element
- GA*, GB* - grid point identification numbers of connecting points
- GO* - grid point identification number of third point
- F[‡] - flag indicating contents of GO (always equal to 2)
- abc[‡], abc[‡] - continuation flag
- PA, PB - pin flags for bar ends A and B, respectively
- Z1A, Z2A, Z3A, Z1B, Z2B, Z3B - components of offset vectors \vec{r}_a and \vec{w}_b , respectively, in displacement coordinate systems at GA and GB, respectively (real number)

The element property description card will be constructed as follows:

1-8	9-16	17-24	25-32	33-40	41-48	49-56	57-64	65-72	73-80
PBAR ⁺	FID [‡]	MID [⊖]	A [⊖]	I1 [⊖]	I2 [⊖]	J [⊖]	NSM [⊖]	X	abc [‡]
+bc [‡]	X	X	X	X	X	X	X	X	cd [‡]
+d [‡]	F1 [⊖]	K2 [⊖]	I12 [⊖]	X	X	X	X	X	X

where

- PBAR⁺ - card identification for simple beam property
- PID⁺ - same as on CBAR card
- MID^e - material identification number
- A^a - area of bar cross section (real number)
- I1^e, I2^e, I12^e - area moment of inertial (real number)
- J^e - torsion constants (real number)
- NSM^e - nonstructural mass per unit length (real number)
- K1^e, K2^e - area factor for shear (real number)
- abc⁺, cd⁺ - continuation card flags

4.15.2.2.2.2 ROD ELEMENT. The element description card will be constructed as follows:

1-8	9-16	17-24	25-32	33-40	41-48	49-56	57-64	65-72	73-80
CONROD ⁺	PID ⁺	G1*	G2*	MID ^e	A ^e	J ^e	X	NSM ^e	X

where

- CONROD⁺ - card identification for element description of a rod element property and connection
- G1*, G2* - grid point identification numbers of connecting points

No element property card will be needed.

4.15.2.2.2.3 QUADRILATERAL MEMBRANE ELEMENT. The element description card will be constructed as follows:

1-8	9-16	17-24	25-32	33-40	41-48	49-56	57-64	65-72	73-80
CQDMEM ⁺	LID ⁺	LID ⁺	G1*	G2*	G3*	G4*	X	X	X

where

CQDMEM⁺ – card identification for element description of a quadrilateral membrane element consisting of four overlapping triangular membrane elements (TRMEM)

PID⁺ – identification number of a PQDMEM property card for element EID

G1*, G2*, G3*, G4* – grid point identification numbers

The element property description card will be constructed as follows:

1-8	9-16	17-24	25-32	33-40	41-48	49-56	57-64	65-72	73-80
PQDMEM ⁺	PID ⁺	MID ^e	T ^e	NSM ^a					

where

PQDMEM⁺ – card identification of property card for element described with CQDMEM card

T^e – thickness of membrane (real number)

NSM^e – nonstructural mass per unit area

The properties of two elements may be described per card image of this type.

4.15.2.2.2.4 ISOPARAMETRIC QUADRILATERAL ELEMENT. The element description card will be constructed as follows:

1-8	9-16	17-24	25-32	33-40	41-48	49-56	57-64	65-72	73-80
CQDMEM1 ⁺	IID*	PID ⁺	G1*	G2*	G3*	G4*			



where

CQDMMEM1⁺ – card identification of element description of an isoparametric quadrilateral element

PID⁺ – identification number of PQDMMEM1 card describing properties of element EID

The PQDMMEM1 element property description card will be exactly like the PQDMMEM card with the exception of the new card identification.

4.15.2.2.2.5 QUADRILATERAL MEMBRANE ELEMENT. The element description card will be constructed as follows:

1-8	9-16	17-24	25-32	33-40	41-48	49-56	57-64	65-72	73-80
CQDMMEM2 ⁺	EID*	PID ⁺	G1*	G2*	G3*	G4*			

where

CQDMMEM2⁺ – card identification of element description of a quadrilateral membrane element consisting of four nonoverlapping triangular membrane elements

PID⁺ – identification number of PQDMMEM2 card describing properties of element EID

The PQDMMEM2 element property description card will be exactly like the PQDMMEM card with the exception of the new card identification.

4.15.2.2.2.6 QUADRILATERAL BENDING ELEMENT. The description of this type of structural element will be placed on a CQDPLT card image. The format of the card will be like that of the CQDMMEM card with the exception of the following two fields.

CQDPLT⁺ - card identification of element description of a quadrilateral bending element

PID⁺ - identification number of a PQDPLT property card

The element property description card will be constructed as follows:

1-8	9-16	17-24	25-32	33-40	41-48	49-56	57-64	65-72	73-80
PQDPLT ⁺	PID ⁺	MID1 ^e	I ^e	MID2 ^e	T ^e	NSM ^a	Z1 ^e	Z2 ^e	

where

PQDPLT⁺ - card identification of property card for quadrilateral bending element described on CQDPLT card

MID1^e - material identification number for bending

I^e - bending area of moment of inertia per unit width (real number)

MID2^e - material identification number for transverse shear

T^e - transverse shear thickness (real number)

NSM^a - nonstructural mass per unit area (real number)

Z1^e, Z2^e - fiber distances for stress computations, positive according to the right-hand sequences defined on the CQDPLT card (real number)

4.15.2.2.2.7 QUADRILATERAL MEMBRANE AND BENDING ELEMENT. The description of this type of structural element will be placed on a CQUAD1 card. With the two exceptions of card identification and element property card reference, the format of the CQUAD1 card will be like that of the CQDMEM card, where

CQUAD1⁺ - card identification

PID⁺ - identification number of a PQUAD1 card containing the property description of the element

The element property description card will be constructed as follows:

1-8	9-16	17-24	25-32	33-40	41-48	49-56	57-64	65-72	73-80
PQUAD1 ⁺	PID ^f	MID1 ^e	T1 ^e	MID2 ^e	I ^e	MID3 ^e	T3 ^e	NSM ^e	abc ^f
+bc ^f	Z1 ^e	Z2 ^e							

where

- PQUAD1⁺ - card identification of element property card for a general quadrilateral element, including bending, membrane, and transverse shear effects
- MID1^e - material identification number for membrane
- T1^e - membrane thickness (real number)
- MID2^e - material identification number for bending
- I^e - area moment of inertial per unit width (real number)
- MID3^e - material identification number for transverse shear
- T3^e - transverse shear thickness (real number)
- NSM^e - nonstructural mass per unit area (real number)
- Z1^e, Z2^e - fiber distance for stress computations (real number)

4.15.2.2.2.8 HOMOGENEOUS QUADRILATERAL MEMBRANE AND BENDING ELEMENT. The element description for this type of element will be placed on a CQUAD2 card image. The format will be the same as for the CQDMEM card with the exceptions that the card identification will be changed as noted and the element property card referenced will be the PQUAD2 type.

The format of the PQUAD2 element property card will be the same as that of the PQDMEM, except for the change of the card type identification.

4.15.2.2.2.9 TENSION-COMPRESSION-TORSION ELEMENT (ROD). The element description card will be constructed as follows:

1-8	9-16	17-24	25-32	33-40	41-48	49-56	57-64	65-72	73-80
CROD ⁺	EID*	PID ⁺	G1*	G2*	X	X	X	X	X

where

CROD⁺ – card identification

PID⁺ – identification number of a PROD card containing properties of this element

G1*, G2* – grid point identification numbers of connection points

The element property description card will be constructed as follows:

1-8	9-16	17-24	25-32	33-40	41-48	49-56	57-64	65-72	73-80
PROD ⁺	PID ⁺	MID ^e	A ^e	J ^e	X	NSM ^d	X	X	X

where

PROD⁺ – card identification

MID^e – material identification number

A^e – area of rod (real number)

J^e – torsion constant (real number)

NSM^d – nonstructural mass per unit length (real number)





4.15.2.2.2.10 SHEAR PANEL ELEMENT. The CSHEAR card, used to describe this type of element, will have the same format as the PQDMEM card but with two exceptions as follows:

CSHEAR⁺ – card type identification

PID⁺ – identification number of a PSHEAR property containing properties of the element

The PSHEAR property description card will be exactly like the PQDMEM card with the exception of the new card type identification.

4.15.2.2.2.11 TRIANGULAR MEMBRANE AND BENDING ELEMENT. The element description card will be constructed as follows:

1-8	9-16	17-24	25-32	33-40	41-48	49-56	57-64	65-72	73-80
CTRIA1 ⁺	EID*	PID ⁺	G1*	G2*	G3*				

where

CTRIA1⁺ – card type identification

PID⁺ – identification number of a PTRIA1 card containing property description of the element

The format of the element property card PTRIA1 will be the same as that of the PQAD1 property card with the exception of the new card type identification.

4.15.2.2.2.12 TRIANGULAR ELEMENT. The CTRIA2 card, the element description card for this element, will have the same format as the CTRIA1 card with two exceptions. The card type identification will be CTRIA2⁺ and the variable PID will reference a PTRIA2 type element property card. The PTRIA2 card will have the same format as a PQDMEM card with the exception of the new card type identification.

4.15.2.2.2.13 TRIANGULAR MEMBRANE ELEMENT. With the exceptions of the new card type identification (CTRMEM) and the reference of the variable PID to a PTRMEM property card, this card image will have the same format as the CTRIAL card. The PTRMEM element property card type will have the same format as the PQDMEM card.

4.15.2.2.2.14 TRIANGULAR BENDING ELEMENT. The description of this type of structural element will be placed on a CTRPLT card. The format of the card will be like that of the CTRIAL card with the exceptions of the following two fields:

CTRPLT⁺ – card identification

PID⁺ – identification of a PTRPLT property card

The PTRPLT element property card will have the same format as the PQDPLT card with the exception of the card identification.

4.15.2.2.2.15 TENSION-COMPRESSION-TORSION ELEMENT (TUBE). The element descriptions of this type of element will be described on CTUBE cards. The format of the CTUBE card will be the same as that for the CROD card.

The element property description card will be constructed as follows:

1-8	9-16	17-24	25-32	33-40	41-48	49-56	57-64	65-72	73-80
PTUBE ⁺	PID ⁺	MID ^a	OD ^b	T ^c	NSM ^d				

where

PTUBE⁺ – card identification for property descriptions of tension-compression-torsion elements

OD^a – outside diameter of tube (real number)

T^c – thickness of tube (real number)

NSM^d – nonstructural mass per unit length

4.15.2.2.3 Material Descriptions

The Model Material File will be read in order to obtain material properties for those materials identified on the element property cards. These data will then be used to construct material property definition card images. Before the card images are constructed, the user will indicate if temperature is to be considered in the analysis.

4.15.2.2.3.1 TEMPERATURE INDEPENDENT ANALYSIS. For this analysis, the material properties of each required material will be placed on MAT1 cards. The element description card will be constructed as follows:

1-8	9-16	17-24	25-32	33-40	41-48	49-56	57-64	65-72	73-80
MAT1 ⁺	MID ^e	E ^{\$}	G ^{\$}	MU ^{\$}	RHO ^{\$}	A ^{\$}	TREF	GE	abc [‡]
+bc [‡]	ST ^{\$}	SC ^{\$}	SS ^{\$}						

where

- MAT1⁺ - card identification for material property independent of temperature
- MID^e - material identification number (same as on element property card images)
- E^{\$} - Young's modulus (real number)
- G^{\$} - shear modulus (real number)
- MU^{\$} - Poisson's ratio (real number)
- RHO^{\$} - mass density (real number)
- A^{\$} - thermal expansion coefficient (real number)
- TREF^{\$} - thermal expansion reference temperature (real number)
- GE - structural element damping coefficient (real number)

ST^{\$}, SC^{\$}, SS^{\$} – stress limits for tension, compression and shear (real number)

abc[‡], bc[‡] – continuation flag

4.15.2.2.3.2 TEMPERATURE DEPENDENT ANALYSIS. The temperature of each grid point will be obtained from the Model Temperature File. Using these data and a data set identification number supplied by the user, the program will construct a TEMP card for each grid point as follows:

1-8	9-16	17-24	25-32	33-40	41-48	49-56	57-64	65-72	73-80
TEMP ⁺	SID ^x	G ^x	T ^x	G ^x	T ^x	G ^x	T ^x		

where

TEMP⁺ – card identification for temperature definition

SID^x – data set identification number

G^x – grid point identification number

T^x – temperature at grid point (real number)

From one to three grid point temperatures can be defined on a single card image.

For each material, a MAT1 card will be constructed; it will contain the mass density (ρ) and the thermal expansion reference temperature. These two material properties will not be temperature dependent. The remaining material properties will be dependent on temperature and will be contained on MATT1 and TABLEM1 card images as follows:

1-8	9-16	17-24	25-32	33-40	41-48	49-56	57-64	65-72	73-80
MATT1 ⁺	MID ^{\$}	R1 [‡]	R2 [‡]	R3 [‡]		R5 [‡]			abc [‡]
abc [‡]	R8 [‡]	R9 [‡]	R10 [‡]						

where

- MAT1⁺ – card identification for material property dependent on temperature
- MID^{\$} -- material property identification which matches the identification number from some MAT1 card
- R1[‡] – identification number of a table containing Young's modulus versus temperature
- R2[‡] – identification number of a table containing shear modulus versus temperature
- R3[‡] – identification number of a table containing Poisson's ratio versus temperature
- R5[‡] – identification number of a table containing thermal expansion coefficients versus temperature
- R8[‡] – identification number of a table containing stress limit for tension versus temperature
- R9[‡] – identification number of a table containing stress limit for compression versus temperature
- R10[‡] – identification number of a table containing stress limit for shear versus temperature
- abc[‡],bc[‡] – continuation flag

The temperature versus material properties tables will be contained on TABLEM1 cards. The data for each temperature dependent variable will be on a separate set of TABLEM1 card images.

1-8	9-16	17-24	25-32	33-40	41-48	49-56	57-64	65-72	73-80
TABLEM1 ⁺	ID ^x								abc [‡]
+bc [‡]	X ₁ ^x	X ₁ ^x	X ₂ ^x	Y ₂ ^x	X ₃ ^x	Y ₃ ^x	ENDT ⁺		

where

- TABLEM1 - card type identification
 ID^x - table identification number as on a MATT1 card image
 abc⁺, bc⁺ - continuation card flag; as many continuation cards as needed may be used
 X₁^x, X₂^x, X₃^x - temperature values (real number)
 Y₁^x, Y₂^x, Y₃^x - data values which correspond to the temperature values (real number)
 ENDT⁺ - flag indicating end of table

4.15.2.2.4 Weight Data Descriptions

In order to obtain weight data for each grid point, the User Weight File will be input to the program. The user will determine which of the following two types of card images will be constructed from the weight data.

1-8	9-16	17-24	25-32	33-40	41-48	49-56	57-64	65-72	73-80
CONM1 ⁺	EID*	G*	CID*	M11°	M21°	M22°	M31°	M32°	abc ⁺
+bc ⁺	M33°	M41°	M42°	M43°	M44°	M51°	M52°	M53°	de ⁺
+e ⁺	M54°	M55°	M61°	M62°	M63°	M64°	M65°	M66°	X





where

- CONM1⁺ - identification of a card set containing a 6 × 6 symmetric mass matrix at a grid point
 EID* - unique element identification number as on an element description card
 G* - grid point identification number
 CID* - coordinate system identification number; unless changed manually this value will always be blank

M_{ij}° - mass matrix values (real number); only those values required need to be present, but all these cards are required

abc^{\mp} , de^{\mp} - continuation flags

The CONM2 card type will define a concentrated mass at a grid point of the structural model.

1-8	9-16	17-24	25-32	33-40	41-48	49-56	57-64	65-72	73-80
CONM2 ⁺	EID*	G*	CID*	M [°]	X1 [°]	X2 [°]	X3 [°]		abc^{\mp}
$+bc^{\mp}$	I11 [°]	I21 [°]	I22 [°]	I31 [°]	I32 [°]	I33 [°]			

where

- CONM2⁺ - card identification
- EID* - unique element identification number as on an element description card
- G* - grid point identification number
- CID* - coordinate system identification number
- M[°] - mass value (real)
- X1[°], X2[°], X3[°] - offset distance
- I11[°], I21[°], I22[°],
I31[°], I32[°], I33[°] - mass moments of inertia measured at the mass center of gravity

4.15.2.2.5 Loads Data Descriptions

The Model Loads File prepared by the Force Inputs to Internal Loads Analysis function will be the next input file. The EDIT subfunction of the Force Inputs to Internal Loads Analysis function will provide all the capability needed for the handling of this file.

4.15.2.3 Output

Output from the NASTRAN input subfunction will consist of a Runstream Input File to be input into NASTRAN. A tabulation (fig. 4.15-2) of the constructed data is also required. The output file will contain card images of NASTRAN bulk data cards. A detailed description of file format and contents is contained in the appendix.

4.15.3 ANALYSIS OF AEROSPACE STRUCTURES BY THE DISPLACEMENT METHOD (AIR FORCE PROGRAM)

4.15.3.1 Input

The data to be used in preparing this runstream can be obtained from any combination of the different files and from manual input. The data files, which are described in the appendix, will be:



- User Model File – This file will supply the grid point identification numbers; X, Y, and Z coordinates of the grid points; and complete element descriptions.
- Element Property File – The structural properties for each element will be contained in this data file.
- Model Temperature File – This file will contain data which describe thermal loading conditions.
- Material Data File – This type of file will contain descriptions of the material properties.
- Model Loads File – Card images, which will be constructed by other ISAS functions, can be retrieved from this file and included in the new runstream.

The capability must be provided to enter additional data of any type listed above, to modify any data obtained from files, and to delete any data.

4.15.3.2 Processing

4.15.3.2.1 Grid Points Description

The User Model File will be read in order to obtain descriptions of all grid points and elements which describe the structural model. The grid point descriptions will be used to construct images of NASTRAN GRID cards.

1-8	9-16	17-24	25-32	33-40	41-48	49-56	57-64	65-72	73-80
GRID ⁺	ID*	CP*	X1*	Y1*	Z1*	CD	PS		

where

- GRID⁺ - card identification
ID* - grid point identification number
CP* - coordinate system identification
X1*, Y1*, Z1* - grid point coordinates
PS, CD - blank unless changed manually

The field CP will always contain blanks since the Air Force Program can accept data for only one coordinate system.

From the element descriptions, the program should construct images of the following NASTRAN element cards:

- CONROD
- CROD
- CTRMEM
- CODMEM
- CSHEAR

The Air Force Program will be limited to the preceding listed element types. All other NASTRAN elements must be converted to one of these types. The program will display these NASTRAN elements, and the user will select which elements are to be converted. This conversion will be based on the number of grid points in the element description. Elements having two grid points will be converted to CROD; those having three grid points will be converted to CTRMEM; and those having four grid points will be converted to CQDMEM. The converted results will be displayed for user verification. Detailed descriptions of each of the element cards can be found in section 4.15.2.2 of this document.

4.15.3.2.2 Element Descriptions

Using the property identification number of each element, the program will read the Element Property File and obtain the structural properties for each element. Images of NASTRAN property cards will then be generated for each element described on the element cards. The type of property card created will be dependent on the type of element card used to describe the element. This correspondence is:

- CROD = PROD
- CTRMEM = PTRMEM
- CONROD = (no property card needed)
- CQDMEM = PQDMEM
- CSHEAR = PSHEAR

Each of these property card types is described in section 4.15.2.2.

4.15.3.2.3 Material Descriptions

The Model Material File will be read in order to obtain material properties for those materials identified on the property card images. These data will then be used to construct material

property definition card images. Before these images are constructed, the user will indicate if temperature is to be considered in the analysis.

4.15.3.2.3.1 TEMPERATURE INDEPENDENT ANALYSIS. For this analysis case, the material properties will be placed on images of MAT1 cards.

1-8	9-16	17-24	25-32	33-40	41-48	49-56	57-64	65-72	73-80
MAT1 ⁺	MID ^e	E ^{\$}	G ^{\$}	MU ^{\$}	RHO ^{\$}	A ^{\$}	TREF	GE	abc [⌘]
+bc [⌘]	ST ^{\$}	SC ^{\$}	SS ^{\$}						

where

- MAT1⁺ — card identification
- MID^e — material identification number (same as on element property card image)
- E^{\$} — Young's modulus (real number)
- G^{\$} — shear modulus (real number)
- MU^{\$} — Poisson's ratio (real number)
- RHO^{\$} — mass density (real number)
- A^{\$} — thermal expansion coefficient (real number)
- TREF^{\$} — thermal expansion reference temperature (real number)
- GE^{\$} — structural element damping coefficient (real number)
- abc[⌘], bc[⌘] — continuation flag
- ST^{\$}, SC^{\$}, SS^{\$} — stress limits for tension, compression, and shear (real number)

4.15.3.2.3.2 TEMPERATURE DEPENDENT ANALYSIS. If thermal loading conditions are to be applied, the user will indicate the required

temperatures and the data will be retrieved from the Model Temperature File. The program should then construct material property card images (as described previously) and images of NASTRAN TEMP cards. The format of the card is shown below.

1-8	9-16	17-24	25-32	33-40	41-48	49-56	57-64	65-72	73-80
TEMP ⁺	SID ^x	G ^x	T ^x	G ^x	I ^x	G ^x	T ^x		

where

TEMP⁺ - card identification

SID^x - temperature set identification number

G^x - grid point identification number

T^x - temperature (real number)

Each card of this type can contain data for one to three grid points. The program should provide the capability to prepare several sets of TEMP cards, which describe different thermal loading conditions. Each set of card images will be identified by a unique temperature set identification (SID) number.

If mechanical loading conditions are to be applied, the program should retrieve images of FORCE cards from the Model Loads File for the required grid points. The program will also provide the capability to display all other card images in the file and to have all selected cards included in the output file. As with the TEMP cards, multiple loading conditions may be prepared in a single pass of the program.

The user will have the capability to have all card images displayed, to delete any card images, and to modify any card images. Also he should have the ability to manually input images of any type card.

4.15.3.3 Output

The output of this function will consist of tabulations of the generated card images and a Runstream Input File. Figure 4.15-2 shows an example of the tabulations; all 80 columns of the card will be displayed. A detailed description of the format and contents of the Runstream Input File is contained in the appendix.

There are no requirements for any type of demand graphics in this subfunction.

4.15.4 AUTOMATED STRUCTURAL OPTIMIZATION PROGRAM (ASOP)

4.15.4.1 Input

Depending on the type of problem being set up, this subfunction will obtain the required data from the following input files.

- User Model File
- Element Property File
- Model Material File
- Model Loads File

Also, the user can input additional information from the remote terminal.

4.15.4.2 Processing

The primary processing required from this function of ISAS will be the preparation of input card images for ASOP. The user must be allowed to specify the type of card image to be created, the order, and the data to be placed on the card image. The structure of the runstream to be prepared is shown in figure 4.15-3. Detailed information on the composition and form of individual segments of the input deck is provided in the following sections. Additional information may be obtained from the technical report AFFDL-TR-74-96, *An Improved Automated*

Structural Optimization Program. The following list indicates the types of data which may be placed in the runstream and the options that must be provided to the user. The user must have the capability to select the data types to be placed in the runstream.

<u>Option</u>	<u>Data Type</u>
1	Initialization data
2	Properties of composite material
3	Allowable stress reduction factors
4	Node geometry and boundary conditions
5	Node geometry only
6	Boundary conditions only
7	Material properties update
8	Member data
9	Load data
10	Condensed boundary conditions
11	Deflection constraints
12	Stability tables

4.15.4.2.1 Initialization Card

Prior to the creation of any large blocks of data describing the structure and loading, one data card will be required to control the sequencing of operations. The format for this image is shown below and contains the following information.

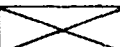
1-2	3-4	5-9	10-14	15-24	25	26-30	31-69	70	71	72	73-80
IS	ID	CC	CD		S	DB	TITLE	CP	CW	CO	TM





where

IS -- maximum number of cycles to be permitted in the initial or stress constraint phase of the synthesis algorithm (I2 format)

- ID - maximum number of cycles to be permitted in the deflection constraint portion of the algorithm (I2 format)
- CC - convergence criterion for weight differences for the initial or stress constraint phase (F5.0 format)
- CD - convergence criterion in the deflection constraint phase (F5.0 format)
- S - clue to select the scaling option; if operative, a "1" will be entered (I1 format)
- DB - five fields (one column each) containing debugging output flags. A nonzero will indicate that the appropriate output has been requested.
- column 26 - intermediate output, such as element matrices, in the initial phase
- column 27 - debugging information in the deflection constraint phase
- column 28 - element corner forces and moments for each cycle
- column 29 - nodal deflections for each cycle
- column 30 - tape and file number locations for the important matrices
- TITLE - any alphanumeric title for the problem (39 characters)
- CP - clue to print element edge shear flows obtained by differencing element nodal forces; if operative, a "1" will be entered (I1 format)
- CW - flag to print orthogonal element warp loads; if operative, a "1" will be entered (I1 format)
- CO - clue to print orthogonal element stresses in the property axis system; if operative, a "1" will be entered (I1 format)
- TM - title of the member matrix following redesign; this may be any alphanumeric name (A8 format)

4.15.4.2.2 Properties Composite Material

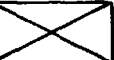
Data describing the properties of the composite materials will follow the initialization. If there are no composite materials in the structure, one blank card should follow the initialization card. Each material used in individual layers of the composite will require two cards to define its properties. A maximum of five composite materials can be placed in a single runstream. The last set of two cards must be followed by a blank card, which will define the end of the Composite Material Table and the beginning of the Allowable Stress Reduction Factor Table. All of the data required to construct these card images will be supplied by the user through the remote terminal. The composite property values that must be supplied will be for the individual layers, in which the fibers will be unidirectional. The cards will be constructed as follows:

Card 1	MATRL	E_{11}	E_{22}	G_{12}	μ_{12}	μ_{21}	THICK	DEN
Card 2	MATRL	F_t	F_c	F_s				

where

- MATRL - identifier for the composite material in the direction of the fibers (I10 format). This may be any number from 1 through 9 and must appear on both cards.
- E_{11} - Young's modulus for the material in the direction of the fibers (E10.0 format)
- E_{22} - Young's modulus for the material transverse to the fibers (E10.0 format)
- G_{12} - shear modulus of the composite (E10.0 format)
- μ_{12} - Poisson's ratio (transverse strain due to axial stress) (E10.0 format)

- μ_{21} - Poisson's ratio (axial strain due to transverse stress)
(E10.0 format)
- THICK - thickness of a single layer (E10.0 format)
- DEN - density in pounds per square inch per layer (E10.0 format)
- F_t - allowable tensile stress in the fiber direction, in
pounds per square inch (E10.0 format)
- F_c - allowable compressive stress in the fiber direction,
in pounds per square inch (E10.0 format)
- F_s - allowable shear stress referred to axes along and trans-
verse to the fiber direction, in pounds per square
inch (E10.0 format)

All of these parameters will be real numbers with the exception of MATRL.

4.15.4.2.3 Allowable Stress Reduction Factors

There will be three allowable stress reduction factor cards: one card each for tension, compression, and shear allowable stresses, in that order. Each card image will contain 20 fields (F4.0) for up to 20 loading conditions, numbered consecutively from left to right. These cards will define factors that will be applied to the metallic element allowable stresses to modify them for different loading conditions. If the allowable stresses are not to be modified, three blank cards should be inserted in the runstream. The allowable stress reduction factors will normally be decimal numbers greater than zero and less than one. All of this data will be input by the user.

4.15.4.2.4 Label Card

All of the data sets in the following description will start with a LABEL card. The LABEL card will have the following form that begins in column 6. The card should contain no blanks between entries.

LABEL(i),NAMEA,NAMEB

where i equals

- 0 - flexible supports (additional stiffness)
 - 1 - geometry and boundary conditions
 - 2 - geometry only
 - 3 - boundary conditions only
 - 4 - material properties update
 - 5 - member data
 - 6 - load data
 - 7 - condensed boundary conditions
 - 8 - deflection constraints
 - 9 - stability tables and splice joint tables
- NAMEA and NAMEB - any alphanumeric names to be associated with the data. Each name may have up to eight characters.

The deck sequence for data sets 1 through 5 must be maintained as shown in figure 4.15-3. The sequence of data sets 8, 9, and 0 will be immaterial.

4.15.4.2.5 Nodal Geometry and Boundary Conditions

At this point, the user will identify the User Model File and the substructures to be included. The program will read the file and construct an image of a geometry and boundary conditions card for each grid point of the selected substructures. The format of this card type will be:

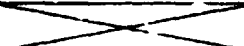
1-4	5-17	18-30	31-43	44-53	54	55	56	57	58	59	60-80
NODE	X	Y	Z		ΔX	ΔY	ΔZ	θX	θY	θZ	

where

NODE - node number (I4 format)
X,Y,Z - coordinates of the node (E13 format)
 $\Delta X, \Delta Y, \Delta Z, \theta X, \theta Y, \theta Z$ - boundary conditions

The boundary conditions can be

- 0 - zero displacement component. This clue will cause the row and column for the particular displacement component to be removed from the structural matrix that is created.
- 1 - "free" (not specified) degrees of freedom.
- 2 - same as 0. (Refer to AFFDL-TR-74-96 for additional information.)

After the program has constructed one of the preceding cards for each node, the user will be required to input the boundary conditions at each node. At the same time, he should be allowed to delete the card or modify any data on the card. The geometry and boundary condition data should be entered with the nodes in ascending numerical order with no numbers missing.

As indicated in the description of the LABEL card, this data set must be preceded by a LABEL(1) card, where:

NAMEA - name for the geometry pseudomatrix (eight characters maximum)

NAMEB - name for the boundary condition pseudomatrix (eight characters maximum)

A blank card must follow the last geometry and boundary conditions card.

4.15.4.2.6 Node Geometry Only

When this option is selected by the user, the program will follow the same procedures as described for the input of geometry and boundary condition data but with two exceptions. The program should not request the user to supply the boundary conditions, and the fields (columns 54 through 59) should be left blank. Also, the data set should be preceded by a LABEL(2) card, where

NAMEA -- name for the geometry pseudomatrix

NAMEB -- blank

4.15.4.2.7 Boundary Conditions Only

All of the data for this data set will be input by the user through the remote terminal. The boundary conditions will be specified using a special condensed format, described below, where the "typical" nodal degrees of freedom will be indicated and all exceptions will be specified. (Refer to page 4-139 for an alternate method of inputting boundary conditions.) The data will be preceded by a LABEL(7), NAMEA card, where NAMEA is the name of the boundary condition pseudomatrix. The first card will indicate the standard degrees of freedom. Columns 1 through 6 will contain 0, 1, or 2 corresponding to the six degrees of freedom -- ΔX , ΔY , ΔZ , θX , θY , and θZ . Columns 7 through 10 will contain the total number of nodes in the structure. The following is an example of the first card:

1	2	3	4	5	6	7-10	11-80
1	1	1	0	0	0	324	

where the standard degrees of freedom are

ΔX -- 1

ΔY -- 1

ΔZ -- 1

0X - 0
 0Y - 0
 0Z - 0

and the number of nodes is 324. The remaining data cards will indicate degrees of freedom that are exceptions to the standard. Twelve fields (starting in column 11) of an I5 format can be used to record this information, with a minus sign indicating "through." For example:

1	2	3	4	5	6	7-10	11-15	16-20	21-25	26-30	31-35	36-40	41-45	46-50	51-55	56-60	61-65	66-70
1	1	2	0	0	0	X	5	8	30	-36	80	X	X	X	X	X	X	X

Nodes 5, 8, 30 through 36, and 80 have degrees of freedom 1, 1, 2, 0, 0, and 0. A blank field within the twelve I5-fields will cause the remaining fields of the card to be ignored. When using this format, all the nodes must appear in the geometry data in consecutive order with no node numbers skipped.

4.15.4.2.8 Material Properties Update

The program ASOP will have a limited number of standard materials that can be incorporated under specific material codes (see table 4.15-1). If the user does not find the appropriate material in the table of standards or if he wishes to input standard minimum and maximum sizes, he can set up his own material codes and associated material tables. This can be done by placing a materials data set in the runstream. The user will first identify a Model Material File and specify the materials to be used. The function will read the file and construct images of standard material cards. For each material, two cards are required as follows:

1	6-8	9-16	17-24	25-32	33-40	41-48	49-56	57-72	73-80
X	MC	ASI	ASC	ASS	LM	PR	D	MI	X

where

- MC - material code always greater than 3 (I3 format)
- AST - allowable stress tension (E8.0 format)
- ASC - allowable stress compression (E8.0 format)
- ASS - allowable stress shear (E8.0 format)
- EM - elastic modulus (E8.0 format)
- PR - Poisson's ratio (E8.0 format)
- D - density (E8.0 format)
- MI - material identity (A15 format)

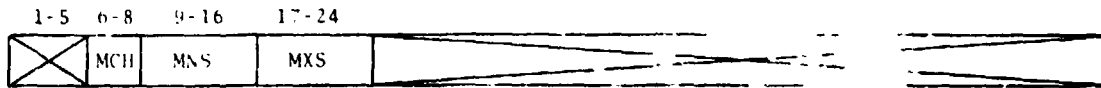

where

- MCH - material code plus 100 (I3 format)
- MNS¹ - minimum size (E8.0 format)
- MXS¹ - maximum size (E8.0 format)

A value for each of the physical properties must be included when inputting a material data set. This data set will be preceded by a LABEL(4) card and will be followed by a blank card. If this data set is used, it must precede the LABEL(5) member data.

4.1.9 4.2.9 Member Data

The member (element) data, which should appear immediately following the load data, will be preceded by a LABEL(5), NAMEA card, where NAMEA is any eight-character alphanumeric name the user wishes to assign to this block of data. The types of

¹Minimum and maximum size will usually denote the thickness or cross-sectional area. Minimum size should never be 0.0.

structure can vary from trusses, which contain bar elements that connect 2 elements and have 1 elastic constant, to anisotropic solids that have members which connect 8 nodes and contain 21 elastic constants. Geometric properties can vary from one for a bar to five for a beam. The only restriction will be when the model includes bar elements adjacent to membrane elements; the data card for any such bar element must not precede the data cards for the adjacent membrane elements.

The member data will be divided into five basic data classes, which in turn will be further subdivided into subclasses. The basic data classes will be:

<u>Data Class</u>	<u>Description</u>
1	Topology and geometric properties
2	Elastic properties
3	Reserved for future use
4	Reserved for future use
5	Allowable stresses and prescribed sizes

Data will be identified as belonging to a specific data class by placing a digit from 1 to 5 in column 15 of the member data card images. The subclasses will be used to identify types of data contained on a member (element) card. The subclass will be placed in column 16. The member data card format is given in figure 4.15-4.

The five data classes will be divided into items according to the following lists. The item number location on the input form is shown in figure 4.15-4. The numbers shown in columns 15 and 16 in figure 4.15-4 are actual data class and subclass numbers. The member number (item 1 in the following lists) must be placed on every card image.

TOPOLOGY AND GEOMETRIC PROPERTIES – DATA CLASS 1

<u>Item</u>	<u>Description</u>
1	Member (element) number. (I4 format)
2	Member type. (See Finite Element Catalog, section 4.15.4.2.10.)
3	Material code will indicate the type of material and its properties. The ASOP program will have built-in standards; however, the user can specify his own material properties by inputting a data set of material properties. (See LABEL(4) data.)
4	Not used.
5	Construction code will be used to select stability tables for the member. (See Stability Tables, section 4.15.4.)
6-25	A maximum of 20 nodes per element. This will be the topological data which will indicate the nodes that a particular member connects. (integer numbers)
26-35	Geometric properties of the member (thickness, area, moment of inertia, etc.). Details of these properties can be found in the Finite Element Catalog. (real numbers)

ELASTIC PROPERTIES – DATA CLASS 2

<u>Item</u>	<u>Description</u>
36-60	These factors will be used to indicate the elastic constants. (real numbers)

DATA FOR FUTURE USE - DATA CLASSES 3 AND 4

<u>Item</u>	<u>Description</u>
61-80	These items will be reserved for possible expansion of ASOP capabilities and will not be used at this time.

ALLOWABLE STRESSES AND PRESCRIBED SIZES - DATA CLASS 5

<u>Item</u>	<u>Description</u>
81-85	The first three items will contain the tension, compression, and shear allowable stresses for the member. As can be seen from figure 4.15-4, they will be entered on the card for 5-1 (class 5, subclass 1). The last two items on the 5-1 card will be reserved for minimum and maximum sizes. (floating point numbers)
86-90	These items, entered on the 5-2 card, will be for the composite layup and, when entered, will serve to establish that the member is of laminated composite construction. Because there will be nine quantities to be entered, the space allocated to each item will be split in half. Starting with the second half of item 86, the following quantities will be entered: l , m , n , l_{min} , m_{min} , n_{min} , l_{max} , m_{max} , and n_{max} , where the first three are starting values of the number of 0° , 90° , and $\pm 45^\circ$ layers, respectively, and the other quantities are present minimum and maximum values of these layers. The quantities in items 86 through 90 are all integers.

The data used to construct this data set (member data) will be obtained from either the User Model File or from the user via the remote terminal keyboard. The element descriptions on the User Model File will be constructed in a way to fit the needs of NASTRAN. This function of ISAS should construct images of ASOP

element cards. The format of these cards is described in the Finite Element Catalog section of this document. With one exception, each NASTRAN element type will have a unique corresponding ASOP element type. The TUBE element type can be converted into either an ASOP type 2 element or a type 11 element. The user must be allowed to control the type of conversion for each TUBE element.

4.15.4.2.10 Finite Element Catalog

The following pages illustrate and describe the input member (element) data for the finite elements that can be input to ASOP. The input data will be placed in fields in accordance with figure 4.15-4. The material code must be provided and may be either a standard code or any code from 1 to 10, provided a material table is included in the runstream (reference LABEL(4) data). Because the 5 1 data class card (containing tension, compression and shear allowable stresses and minimum and maximum sizes) will be in the same format for all the elements (fig. 4.15-4), it is omitted in the following pages. Only topology, elastic property information, and stress output are shown.

Special care should be exercised in entering the angle β , which is used when property axes differ from element axes. This angle will always be measured from the element X_1 -axis. It should also be noted that, in numbering the nodes of the quadrilateral elements, i-j need not be in the counterclockwise direction, as required by NASTRAN.

4.15.4.2.10.1 ELEMENT 1: BAR ELEMENT (NASTRAN - CONROD, CROD)

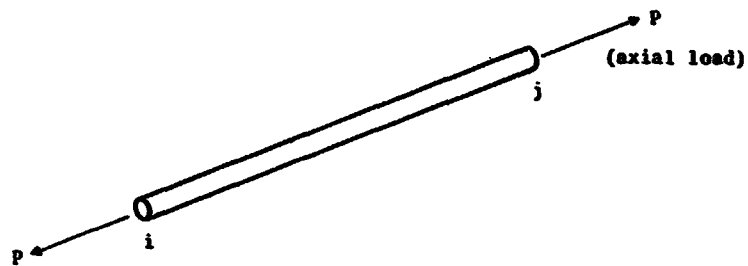

INPUT

Member Number	Member Type	Materials Code	Graphics	Construction Code	Data Class	Subclass	Node 1	Node 2	Node 3	Node 4	Factor 1	Factor 2	Factor 3	Factor 4	Factor 5
No. 1					1	1	i	j			Area				
*					2	1					E				

Note:

E - modulus of elasticity

*This card will be needed on, when overriding program-stored properties.

**ORIGINAL PAGE IS
OF POOR QUALITY**

4.15.4.2.10.2 ELEMENT 2: BEAM ELEMENT (NASTRAN - CBAR)

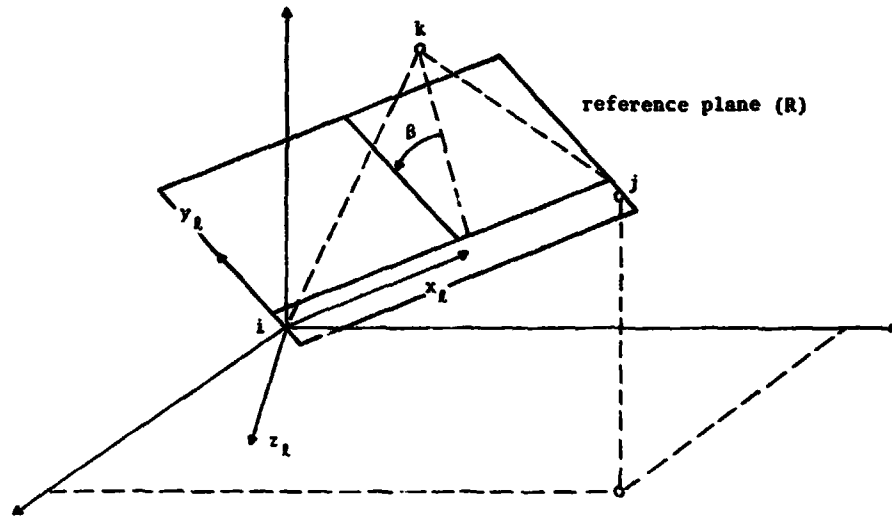

Nodes i, j, and k will determine reference plane R. Angle β will determine orientation of y_L, z_L axes with respect to reference plane R.

For the offset beam, nodes i and j will be the structural connection nodes and nodes k and m will be the beam centroid nodes. Node k will determine the orientation of the beam.

INPUT

Member Number	Member Type	Materials Code	Graphics	Construction Code	Data Class	Subclass	Node 1	Node 2	Node 3	Node 4	Factor 1	Factor 2	Factor 3	Factor 4	Factor 5
No.	2				1	1	i	j	k	l	Area	B	I_{yy}	I_{zz}	J
†					1	2	m								
*					2	1					E				

Note:

B - is in degrees

J - effective polar moment of inertia

E - modulus of elasticity

*This card will be needed only when overriding program-stored properties.

†This card will be needed only when using induced offsets.

ORIGINAL PAGE IS
OF POOR QUALITY

4.15.4.2.10.3 ELEMENT 4: TRIANGULAR MEMBRANE ELEMENT (NASTRAN - CTRMEM)

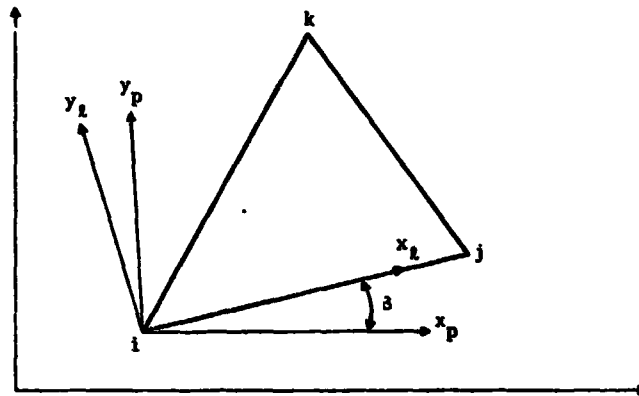

The local axes will be x_l and y_l . The local property axes will be x_p and y_p . Nodes will be numbered in counterclockwise fashion.

input

Isotropic and Orthotropic

Member Number	Member Type	Materials Code	Graphics	Construction Code	Data Class	Subclass	Node 1	Node 2	Node 3	Node 4	Factor 1	Factor 2	Factor 3	Factor 4	Factor 5
No. 4					1 1	i j k					t				
*					2 1						A_{11}	A_{22}	A_{33}	A_{12}	

Anisotropic

No. 4					1 1	i j k					t				
*					2 1						A_{11}	A_{22}	A_{33}	A_{12}	A_{23}
*					2 2						A_{13}				

Note:

t - thickness of element

β - given in degrees

Elastic factors (A_{11} , etc.) will be elements of stress-strain law:

$$\begin{pmatrix} \sigma_x \\ \sigma_y \\ \tau_{xy} \end{pmatrix} = \begin{bmatrix} A_{11} & A_{12} & A_{13} \\ A_{21} & A_{22} & A_{23} \\ A_{31} & A_{32} & A_{33} \end{bmatrix} \begin{pmatrix} \epsilon_x \\ \epsilon_y \\ \gamma_{xy} \end{pmatrix}$$

*This card will be needed only when overriding program-stored properties.

**4.15.4.2.10.4 ELEMENT 5: QUADRILATERAL MEMBRANE ELEMENT
(NASTRAN - CQDMEM, CQDMEM1)**

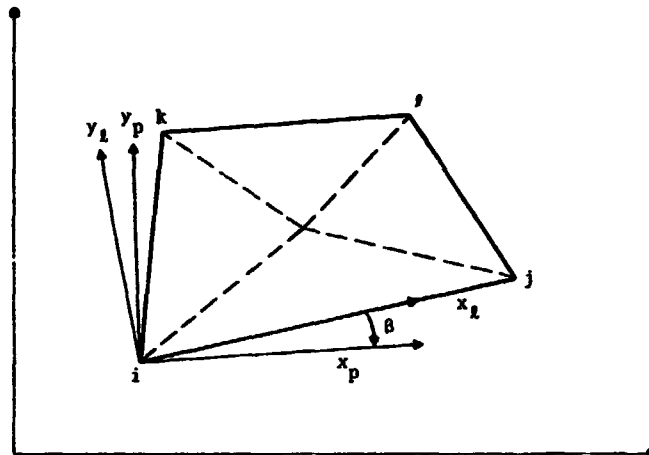

Element 5 will be composed of four triangular elements. The local axes will be x_l and y_l . The local property axes will be x_p and y_p .

INPUT

Isotropic and Orthotropic

Member Number	Member Type	Materials Code	Graphics	Construction Code	Data Class	Subclass	Node 1	Node 2	Node 3	Node 4	Factor 1	Factor 2	Factor 3	Factor 4	Factor 5
No. 5				1	1	i	j	k	l	t	θ				
*				2	1						A_{11}	A_{22}	A_{33}	A_{12}	

Anisotropic

No. 5				1	1	i	j	k	l		θ				
*				2	1						A_{11}	A_{22}	A_{33}	A_{12}	A_{23}
*				2	2						A_{13}				

Note:

t - thickness of element

θ - given in degrees

Elastic factors (A_{11} , etc.) will be elements of stress-strain law:

$$\begin{pmatrix} \sigma_x \\ \sigma_y \\ \tau_{xy} \end{pmatrix} = \begin{bmatrix} A_{11} & A_{12} & A_{13} \\ A_{21} & A_{22} & A_{23} \\ A_{31} & A_{32} & A_{33} \end{bmatrix} \begin{pmatrix} \epsilon_x \\ \epsilon_y \\ \gamma_{xy} \end{pmatrix}$$

*This card will be needed only when overriding program-stored properties.

4.15.4.2.10.5 ELEMENT 6: QUADRILATERAL SHEAR PANEL
(NASTRAN - CSHEAR)

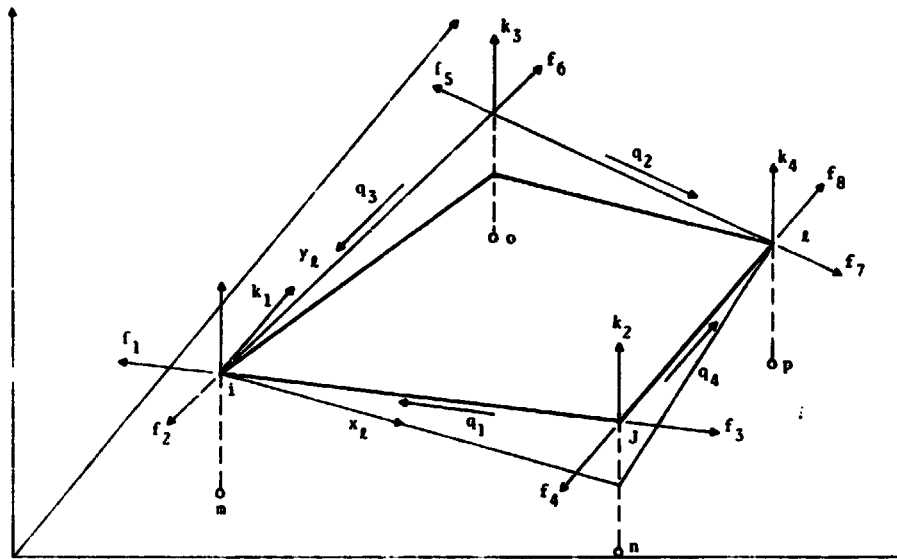

Panel can be warped or planar.

INPUT

Member Number	Member Type	Materials Code	Graphics	Construction Code	Data Class	Subclass	Node 1	Node 2	Node 3	Node 4	Factor 1	Factor 2	Factor 3	Factor 4	Factor 5
No. 6				1	1		i	j	k	l	t				
No.				1	2		m	n	o	p					
No.				2	1						E	G			

Note:

t - thickness of panel

E - modulus of elasticity

G - shear modulus

Nodes m, n, o, and p will be optional (data card 12). They will be used to specify the directions of the "kick" forces. When nodes m, n, o, and p are specified, the direction of the "kick" forces will be from i to m, from j to n, from k to o, and from l to p. When these nodes are not specified (card 12 is left out), the direction of the "kick" forces will be perpendicular to the two adjacent sides at a node and its sense is as shown above.

ORIGINAL PAGE IS
 OF POOR QUALITY

4.15.4.2.10.6 ELEMENT 8: WARPED QUADRILATERAL (NASTRAN - CQDMEM2)

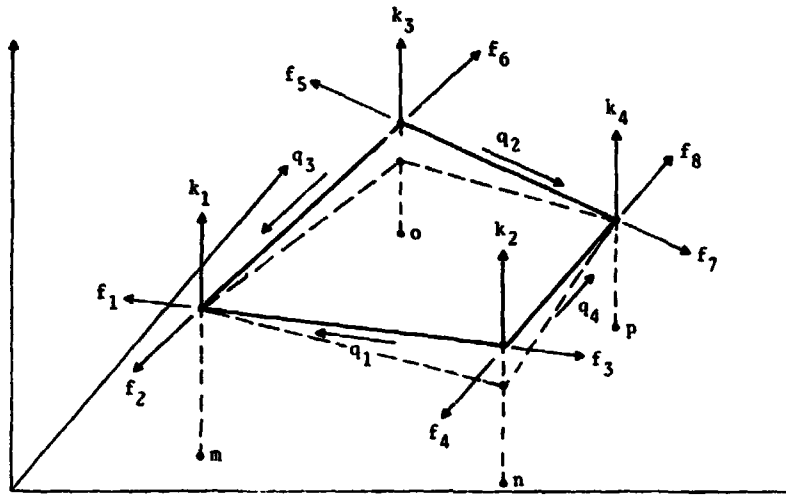

INPUT

Isotropic and Orthotropic

Member Number	Member Type	Materials Code	Graphics	Construction Code	Data Class	Subclass	Node 1	Node 2	Node 3	Node 4	Factor 1	Factor 2	Factor 3	Factor 4	Factor 5
No. 8				1	1	i j k t	t	t	t	t	t	t	t	t	t
No.				1	2	m n o p									
No.				2	1						A_{11}	A_{22}	A_{33}	A_{12}	

Anisotropic

No. 8				1	1	i j k t	t	t	t	t	t	t	t	t	t
No.				1	2	m n o p									
*				2	1						A_{11}	A_{22}	A_{33}	A_{12}	A_{23}
*				2	2						A_{13}				

Note:

Nodes m, n, o, p will be optional (data card 12). They will be used to specify the directions of the "kick" forces. If data card 12 is left out, direction of "kick" forces will be perpendicular to adjacent sides at node and in the directions shown in the figure.

t - thickness of element

β - angle between property axes and side i-j; given in degrees.

Elastic factors (A_{11} , etc.) will be elements of stress-strain law:

$$\begin{matrix} \sigma_x & A_{11} & A_{12} & A_{13} & \epsilon_x \\ \sigma_y & A_{21} & A_{22} & A_{23} & \epsilon_y \\ \tau_{xy} & A_{31} & A_{32} & A_{33} & \gamma_{xy} \end{matrix}$$

*This card will be needed only when overriding program-stored properties.

ORIGINAL PAGE IS
OF POOR QUALITY

4.15.4.2.10.7 ELEMENT 11: BEAM ELEMENT (NASTRAN - CBAR)

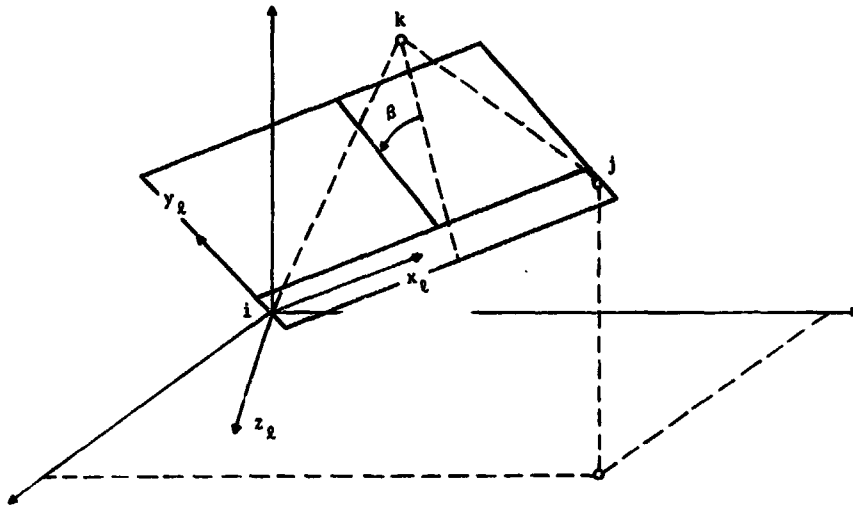

Hinge will exist at node j on z_2 axis. Nodes i, j, and k will determine reference plane R. Angle β will determine orientation of y_2 and z_2 axes with respect to reference plane R.

INPUT

Member Number	Member Type	Materials Code	Graphics	Construction Code	Data Class	Subclass	Node 1	Node 2	Node 3	Node 4	Factor 1	Factor 2	Factor 3	Factor 4	Factor 5
No. 1	1				1	1	i	j	k		Area	β	I_{yy}	I_{zz}	J
*					2	1					E				

Note:

β - given in degrees

J - effective polar moment of inertia

E - modulus of elasticity

*This card will be needed only when overriding program-stored properties.

ORIGINAL PAGE IS
OF POOR QUALITY

4.15.4.2.10.8 ELEMENT 15: TRIANGULAR BENDING ELEMENT (NASTRAN - CTRPLT)

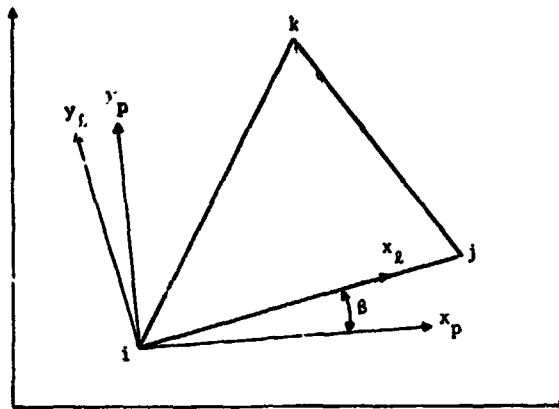

Nodes will be numbered in counterclockwise fashion. The local axes will be x_l and y_l . The local property axes will be x_p and y_p .

INPUT

Isotropic and Orthotropic

Member Number	Member Type	Materials Code	Graphics	Construction Code	Data Class	Subclass	Node 1	Node 2	Node 3	Node 4	Factor 1	Factor 2	Factor 3	Factor 4	Factor 5
No. 15					1	1	i	j	k		t	β			
*					2	1					A_{11}	A_{22}	A_{33}	A_{12}	

Anisotropic

No. 15					1	1	i	j	k		t	β			
*					2	1					A_{11}	A_{22}	A_{33}	A_{12}	A_{23}
*					2	2					A_{13}				

Note:

t - thickness of element

β - given in degrees (positive direction will be clockwise measuring from i-j line)

Elastic factors (A_{11} , etc.) will be elements of stress-strain law:

$$\begin{pmatrix} \sigma_x \\ \sigma_y \\ \tau_{xy} \end{pmatrix} = \begin{bmatrix} A_{11} & A_{12} & A_{13} \\ A_{21} & A_{22} & A_{23} \\ A_{31} & A_{32} & A_{33} \end{bmatrix} \begin{pmatrix} \epsilon_x \\ \epsilon_y \\ \gamma_{xy} \end{pmatrix}$$

*This card will be needed only when overriding program-stored properties.

**4.15.4.2.10.9 ELEMENT 16: QUADRILATERAL BENDING ELEMENT
(NASTRAN - QDPLT)**

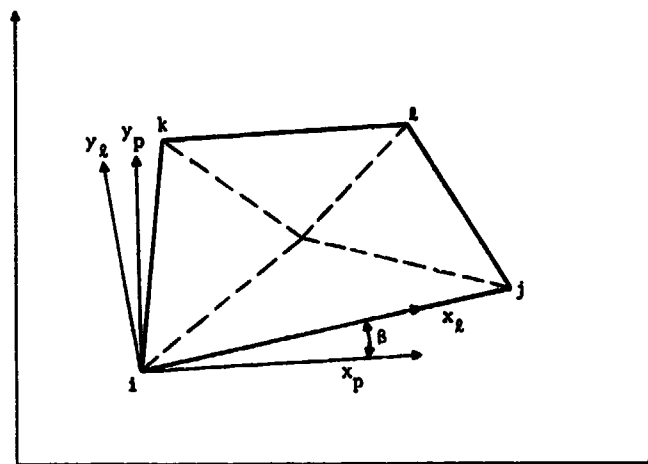

Element 16 will be composed of four triangular elements. The local axes will be x_l and y_l . The local property axes will be x_p and y_p .

INPUT

Isotropic and Orthotropic

Member Number	Member Type	Materials Code	Graphics	Construction Code	Data Class	Subclass	Node 1	Node 2	Node 3	Node 4	Factor 1	Factor 2	Factor 3	Factor 4	Factor 5
No. 16					1	1	i	j	k	l	t	B			
*					2	1					A_{11}	A_{22}	A_{33}	A_{12}	

Anisotropic

No. 16					1		i	j	k	l	t	B			
*					2	1					A_{11}	A_{22}	A_{33}	A_{12}	A_{23}
*					2						A_{13}				

Note:

t - thickness of element

B - given in degrees

Elastic factors (A_{11} , etc.) will be elements of stress-strain law:

$$\begin{pmatrix} \sigma_y \\ \sigma_x \\ \tau_{xy} \end{pmatrix} = \begin{bmatrix} A_{11} & A_{12} & A_{13} \\ A_{21} & A_{22} & A_{23} \\ A_{31} & A_{32} & A_{33} \end{bmatrix} \begin{pmatrix} \epsilon_x \\ \epsilon_y \\ \gamma_{xy} \end{pmatrix}$$

*This card will be needed only when overriding program-stored properties.

4.15.4.2.10.10 ELEMENT 17: TRIANGULAR MEMBRANE AND BENDING ELEMENT (NASTRAN - CTRIA1, CTRIA2). The input format for element type 17 will be the same as for element type 4.

4.15.4.2.10.11 ELEMENT 18: QUADRILATERAL MEMBRANE AND BENDING ELEMENT (NASTRAN - CQUAD1, CQUAD2). The input format for element type 18 will be the same as for element type 5.

4.15.4.2.11 Load Data

This data set will follow the one described in the Boundary Conditions section (LABEL(3), LABEL(4), or LABEL(7)). The first card will be a LABEL(6),NAME(M) card, where NAME is an eight-character name of the pseudomatrix and M is the number of load conditions (columns). The card images containing the loads data will follow the LABEL card. Each of these card images can contain one, two, or three load values. It should be noted that only nonzero values of the loads can be input. The format of the loads card will be as follows:

1-4	5-6	7-10	11-24	25-28	29-30	31-34	35-48	49-52	53-54	55-58	59-72
NODE	COMP	COND	VALUE	NODE	COMP	COND	VALUE	NODE	COMP	COND	VALUE

where

NODE -- grid point identification number

COMP -- component (F_x , F_y , F_z , M_x , M_y , M_z)

COND -- column number

VALUE -- load value (floating point)

As with all data sets, a blank card will follow the last load card. The data to be placed on these card images will be obtained from the Model Loads File and manual input through the remote terminal.

4.15.4.2.12 Condensed Boundary Conditions

This option is the same as that described in the Boundary Conditions Only section (option 6).

4.15.4.2.13 Deflection Constraints

Deflection constraint data will be preceded by a LABEL(8),NAMEA card. Each data card will contain the maximum and minimum values of ΔX , ΔY , and ΔZ for a particular node and the load cases for which these constraints apply. Here "maximum and minimum" will correspond to the largest absolute values of ΔX , ΔY , and ΔZ in the positive and negative directions of the global coordinate axes. The absolute values (i.e., no negative values) are to be entered on the card. The deflection constraints listed on any one card can apply to a maximum of 10 load cases, and the cards must be arranged in ascending numerical order of the nodes. All of the data for this data set will be supplied by the user via the remote terminal. The deflection constraints data will be constructed in the following format.

1-4	5-6	7-14	15-22	23-24	25-32	33-40	41-42	43-50	51-58	59-60	61-80
NODE	ΔX_{max}	ΔX_{min}	ΔY_{max}	ΔY_{min}	ΔZ_{max}	ΔZ_{min}	Load Cases				

where

NODE — grid point identification number

ΔX_{max} ΔX_{min} — real values for maximum and minimum deflection in X-direction

ΔY_{max} ΔY_{min} — real values for maximum and minimum deflection in Y-direction

ΔZ_{max} ΔZ_{min} — real values for maximum and minimum deflection in Z-direction

Load Cases — from 1 to 10 load cases (I2 format)

4.15.4.2.14 Stability Tables

For some structural problems, design allowable stresses may have to be altered to prevent local instability of various members. These allowables will usually be functions of the load levels to which the member has been subjected and will be entered as tables. Stability tables may be supplied for the sizing of element types 1, 5, 6, and 8 only. The stability table data set will begin with the LABEL(9),NAME card. The stability tables (maximum of 17) will follow this card, and the data set will be terminated by a blank card. Each stability table will contain a header card specifying the table number (card columns 9 to 12, I4), the number of values of the abscissa (card columns 13 and 14, I2), and the number of curves in the table (card columns 15 and 16, I2). ASOP will be limited to handling nine abscissas and nine curves per table. Following the header card will be a card specifying the values of the abscissa for which allowable stresses are given. This data card will be constructed using the following format.

1-7	8-14	15-21	22-28	29-35	36-42	43-49	50-56	57-63	64-70	71-77	78-84
X	A_1	A_2	A_3	A_4	A_5	A_6	A_7	A_8	A_9	I	X

where

A_1 through A_9 – values of the abscissa (real number, E7.0 format)

I – sequence number (I2 format)

Next, the value of the second independent variable and corresponding allowable stresses for that variable will be entered, one per card. This card image will be constructed in the following format.

1-7	8-14	15-21	22-28	29-35	36-42	43-49	50-56	57-63	64-70	71-77	78-84
Q	S_1	S_2	S_3	S_4	S_5	S_6	S_7	S_8	S_9	I	X

where

- Q - value of the second independent variable (real number, E7.0 format)
- S₁ through S₉ - values of allowable stresses (real number, E7.0 format)
- I - sequence number (I2 format)

Each succeeding card (curve) will be completed as defined by its header card. Another table header card will follow, and the process will continue until a blank card indicates the end of the data set. All of the data required for this data set will be supplied by the user through the remote terminal.

4.15.4.3 Output

Output from this subfunction will consist of a Runstream Input File to be input into ASOP. A tabulation of the constructed runstream is also required. The user must have the capability to modify, delete, or add to any of the data displayed in the tabulation. The output file will contain card images of ASOP data cards. A detailed description of the file format is contained in the appendix.

This subfunction has no requirement for plot output.

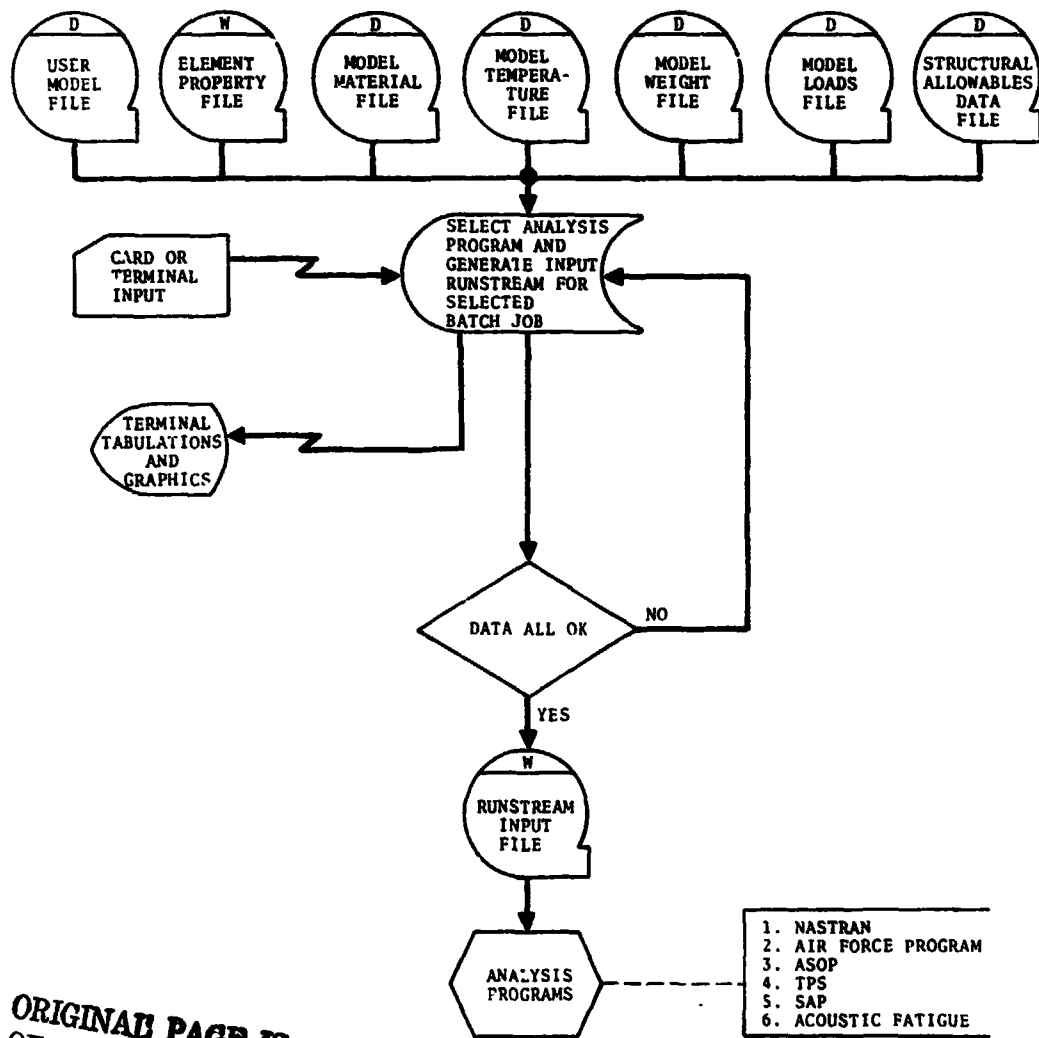

Figure 4.15-1. — Data flow diagram for Internal Loads and Dynamic Characteristics.

LINE	11111111	22222222	33333333	44444444	55555555
	66666666	77777777	88888888	99999999	00000000
1	FORCE	111	1	222	111
		111	111		
2	MOMENT	111	1	222	111
		111	111		
3	FORCE	111	2	222	22
		22	222		
4	MOMENT	111	2	222	222
		222	222		
5	FORCE	111	3	222	333
		333	333		

ANY MODIFICATIONS OR DELETIONS Y OR N

Figure 4.15-2. - Example tabulation of force and moment cards.

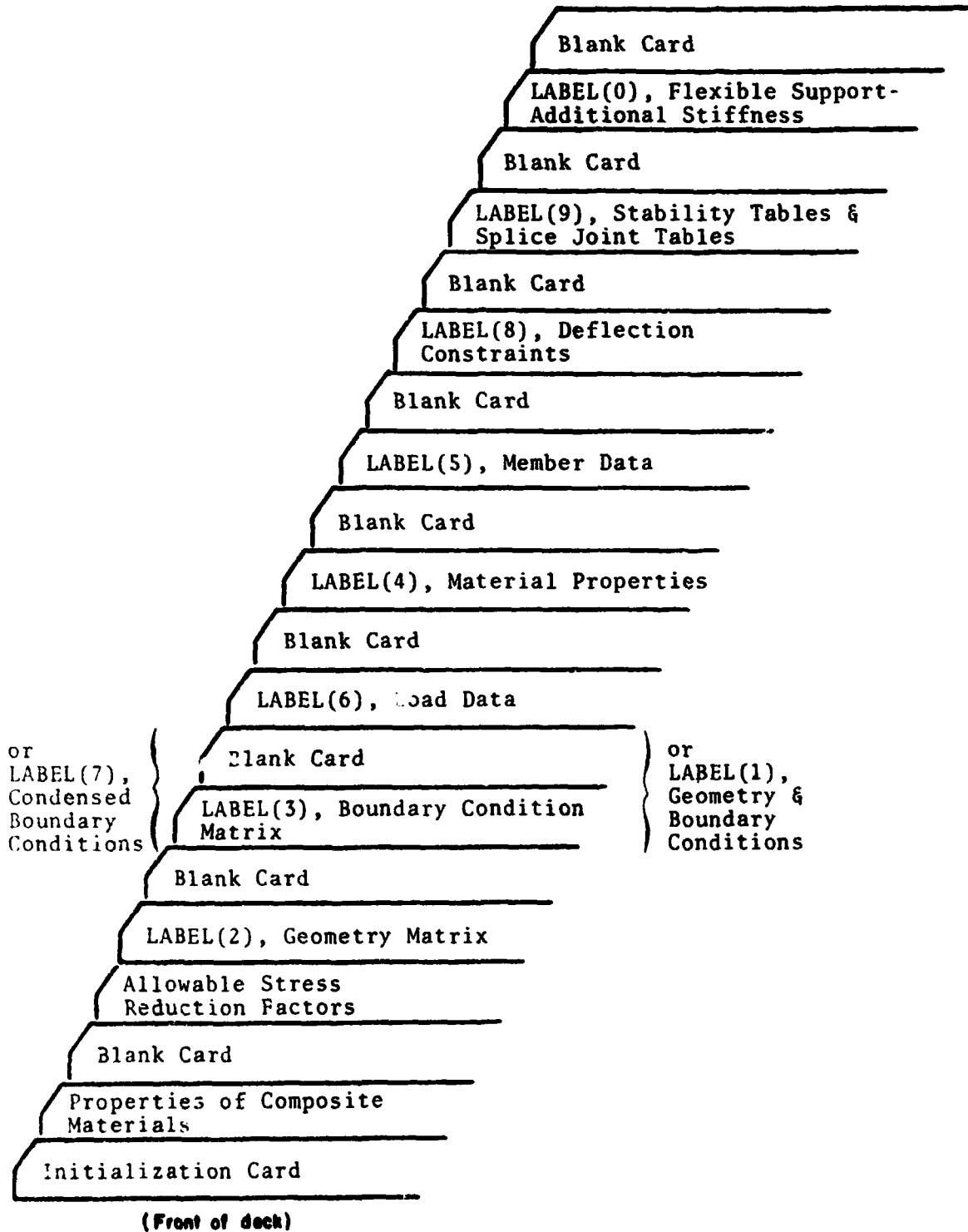

Figure 4.15-3. - Construction of input deck.

TABLE 4.15-1. - STANDARD MATERIALS

Material Code	Material	Density no./in ³	Elastic Modulus	Poisson's Ratio	Allowable Stresses		
					Tension	Comp.	Shear
1	Aluminum	0.100	1.05×10^7	0.3	67,000	57,000	39,000
2	Steel	0.285	2.95×10^7	0.3	220,000	213,000	129,000
3	Titanium	0.160	160×10^7	0.3	130,000	127,000	76,000
.							
.							
.							
10							

4.16 LANDING FLIGHT CONDITIONS

The requirement to provide support in this area w's deleted by the Structures Branch (ES2). Figure 4.16-1 is a data flow diagram of the Landing Flight Conditions function.

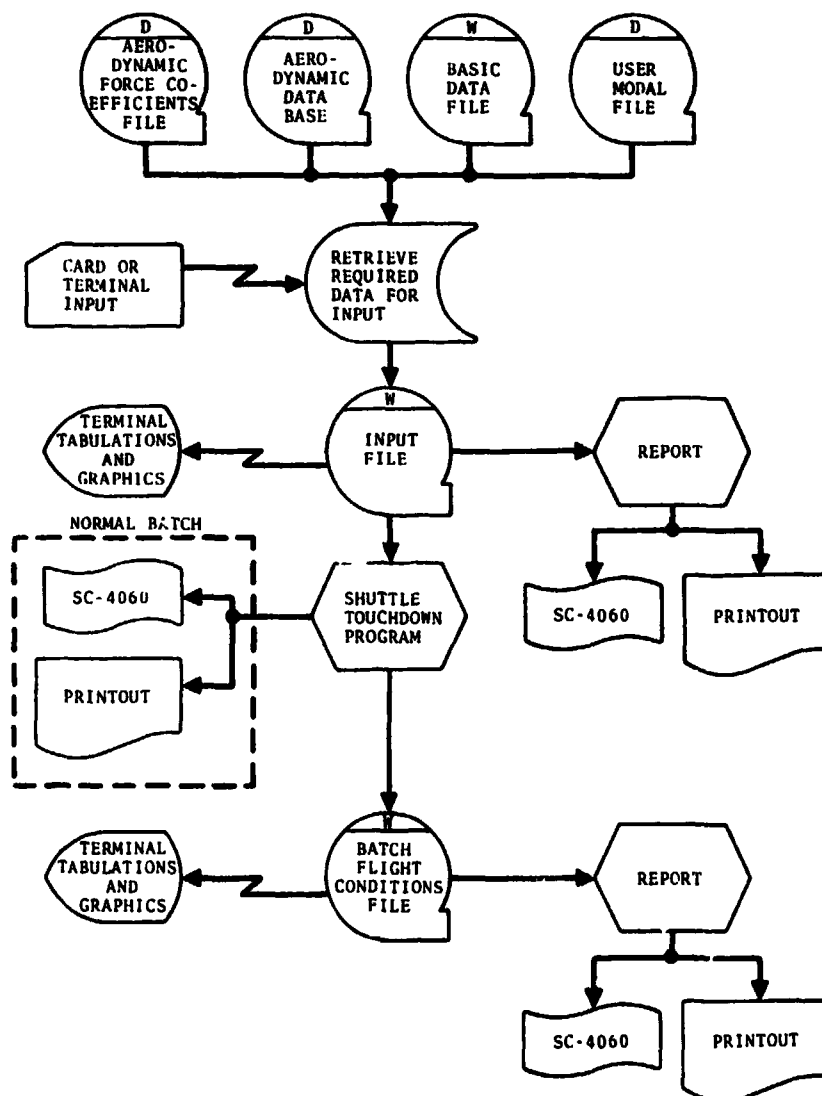

Figure 4.16-1. - Data flow diagram for Landing Flight Conditions.

ORIGINAL PAGE IS
OF POOR QUALITY

4.17 LIFTING SURFACE FLUTTER/UNSTEADY AERODYNAMIC FORCES

The Lifting Surface Flutter/Unsteady Aerodynamic Forces function is divided into two subsystems. The first subsystem is the Unsteady Aerodynamic Forces, which will generate a data file for the second subsystem, the Lifting Surface Flutter. Figure 4.17-1 is a data flow diagram of this function.

4.17.1 UNSTEADY AERODYNAMIC FORCES

4.17.1.1 Purpose

This subsystem is needed in order to create the Unsteady Aerodynamic Input File. This file will contain all the data needed by a series of batch programs to compute unsteady aerodynamic forces and force related quantities.

These data will be output by the batch programs onto the Unsteady Aerodynamic Output File. This subsystem will also produce terminal tabulations and graphical displays of the data contained on this output file.

These data are also required as input to several other ISAS functions. For this purpose, the Unsteady Aerodynamic Forces subsystem will reformat the data to three output files: the Unsteady Flutter Generalized Forces File, the Unsteady Gust Generalized Forces File, and the Static Aerodynamic Influence Coefficients File.

4.17.1.2 Input

The data files required as input to this subsystem will be the User Modal File and the Standard Atmosphere File. The descriptions of these files can be found in the appendix of this document. The user will have the capability to supplement or modify any of the data obtained from these files.

The user will also input by cards or at the remote terminal any information needed by this subsystem to produce the desired output. This information will include:

- Control grid points
- Mach number
- Altitude
- Set of reduced frequencies
- Format ID for tabulations and graphics

4.17.1.3 Processing

The processing to be performed by this subsystem will be divided into four subfunctions which are:

- Interpolate modal data to aerodynamic control points
- Form Unsteady Aerodynamic Input File
- Display data from Unsteady Aerodynamic Output File
- Select and reformat output file

4.17.1.3.1 Interpolate Modal Data to Aerodynamic Control Points (Subfunction 1)

This subfunction will interpolate the normal mode displacement data obtained from the User Modal File to a set of aerodynamic control points. The set of modes and grid points to be used in this analysis will be selected from the User Modal File. For each mode selected, the modal frequency and modal displacement data will be retrieved from the file. The aerodynamic control point numbers and their coordinates will be input by cards or at the terminals.

A three dimensional interpolation routine will be used to interpolate the modal displacement data to the aerodynamic control points. The interpolated modal displacement data along with the

the mode numbers, aerodynamic control points, and modal frequencies will be output on the Interpolated Control Point File.

4.17.1.3.2 Form Unsteady Aerodynamic Input File (Subfunction 2)

This subfunction will generate the Unsteady Aerodynamic Input File which will contain all the input data needed by the series of batch programs to compute unsteady aerodynamic forces and force related quantities.

Modal frequencies and modal displacement data will be input from the Interpolated Control Point File. Mach number, altitude, and a set of reduced frequencies will be input by cards or at the remote terminal. The altitude will be used to retrieve air density from the Standard Atmosphere File. The units of air density on this file will be kilograms per cubic meter. If different units are required by the batch analysis programs, the user can input the units desired and the subfunction will convert air density to the desired units.

All of these data can be tabulated for user verification and will be output on the Unsteady Aerodynamic Input File. Graph displays of the modal displacement data will be required.

4.17.1.3.3 Display Data From Unsteady Aerodynamic Output File (Subfunction 3)

The Unsteady Aerodynamic Output File will contain all unsteady aerodynamic forces and force related quantities output by the series of unsteady aerodynamic batch programs. This subfunction will produce tabulations and graphical output of the data contained on this file.

Tabulations will consist of displaying both the real and imaginary parts of the following complex matrices: downwash distribution, unsteady aerodynamic influence coefficients, aerodynamic

pressure distribution, and unsteady aerodynamic generalized forces. Tabulations will also be required of the area matrix. Examples of these tabulations are given in figures 4.17-2 through 4.17-6.

Graphical displays consisting of planform plots and chordwise plots will be required for the downwash distribution, the aerodynamic pressure distribution, and the unsteady aerodynamic generalized forces. For both types of plot, the user will have the option of selecting the coordinate axis to be used in generating each display. The user will also have the option of displaying both the real and imaginary components on the same display or on separate displays. An example of the chordwise plot is given in figure 4.17-7.

4.17.1.3.4 Select and Reformat Output File (Subfunction 4)

This subfunction will reformat the data from the Unsteady Aerodynamic Output File to the format to be used by other ISAS functions. The user will select which of the three output files (Unsteady Flutter Generalized Forces File, Unsteady Gust Generalized Forces File, or Static Aerodynamics Influence Coefficient File) is to be generated. A description of these files is given in the appendix of this document. After the user selects the output file, this subfunction will automatically reformat the data to this file.

4.17.1.4 Output

Output from this subsystem will consist of the following data files:

- Interpolated Control Point File
- Unsteady Aerodynamic Input File
- Unsteady Aerodynamic Output File

- Unsteady Flutter Generalized Forces File
- Unsteady Gust Generalized Forces File
- Static Aerodynamic Influence Coefficients File

A description of these data files is given in the appendix of this document.

In addition to these files, tabulations and graphical displays of the data contained on these files will be output. This output will be the same as described in the preceding sections.

4.17.2 LIFTING SURFACE FLUTTER

4.17.2.1 Purpose

The purpose of this subsystem is two-fold. First it will create an input file containing all necessary data for the batch Flutter Solution Program; the output from this batch program will be contained on the Lifting Surface Flutter Output File. Secondly, this subsystem will produce tabulations and graphical displays of the data contained on this file.

4.17.2.2 Input

The data files required as input to this subsystem are:

- NASTRAN Output-2 File
- Unsteady Flutter Generalized Forces File
- User Modal File
- Interpolated Control Point File

The descriptions of these files can be found in the appendix of this document. The user will have the capability to supplement or modify any of the data obtained from these files. Any additional data needed by this subsystem will be input by cards or at the remote terminal.

4.17.2.3 Processing

The processing to be performed by this subsystem is divided into two subfunctions, the Form Lifting Surface Flutter Input File and the Display Data from Lifting Surface Flutter Output File.

4.17.2.3.1 Form Lifting Surface Flutter Input File (Subfunction 1)

This subfunction will generate the Lifting Surface Flutter Input File which will contain all the input data needed by the batch Flutter Solution Program. These input data will be retrieved from several different files. Mass data will be retrieved from the User Modal File. Stiffness data will be retrieved from the NASTRAN Output-2 File. The unsteady generalized forces will be retrieved from the Unsteady Flutter Generalized Forces File. After these data have been retrieved, they can be tabulated for user verification. They will then be output on the Lifting Surface Flutter Input File.

4.17.2.3.2 Display Data From Lifting Surface Flutter Output File (Subfunction 2)

The Lifting Surface Flutter Output File will contain all the flutter solution data output by the batch Flutter Solution Program. This subfunction will produce tabulations and graphical displays of the data contained on this file. These data will consist of flutter solution data and flutter mode shape data. The flutter solution data will include Mach number, altitude, flutter velocity, flutter damping, flutter frequency, and reduced frequency and should be tabulated according to the format given in figure 4.17-8. The flutter mode shape data will include mode number, grid points, and modal displacement and should be tabulated according to the format given in figure 4.17-9.

Five graphical displays are required for data contained on this file. Display 1 will be a plot of flutter velocity versus flutter damping for a given Mach number and altitude. The flutter velocity will be along the abscissa and the flutter damping along the ordinate. The user will have the option of specifying the units to be used for flutter velocity.

Display 2 will be a plot of flutter velocity versus flutter frequency. The flutter frequency will be along the ordinate axis, and the user will have the option of specifying the units for both the velocity and frequency.

Display 3 will be a plot of Mach number versus dynamic pressure. The Mach number will be along the abscissa and dynamic pressure along the ordinate. The flight envelope and flutter limit will also be plotted along the ordinate. The flight envelope will be input by the user. The flutter limit will be equal to 1.32 times the flight envelope. Dynamic pressure will be equal to one-half the air density times the flutter velocity squared. The air density will be retrieved from the Lifting Surface Flutter Output File, and the flutter velocity will be retrieved as follows. For each Mach number on the file, the flutter damping value of zero will be located. At this point, the flutter velocity will be retrieved. An example of this display is given in figure 4.17-10.

Displays 4 and 5 will be displays of the flutter mode shapes. Display 4 will be a fixed time point plot of the flutter modal deformation. Display 5 will be a sinusoidal plot of the deformation. This plot will be the same as the modal movies required in the NASTRAN Postprocessing function.

4.17.2.4 Output

The only data files output by this subsystem will be the Lifting Surface Flutter Input File and the Lifting Surface Flutter Output File. Descriptions of these files are given in the appendix of this document. The tabulations and graphical output from this function are described in detail in the preceding discussion of the processing required by each subfunction.

UNSTEADY AERODYNAMIC FORCES

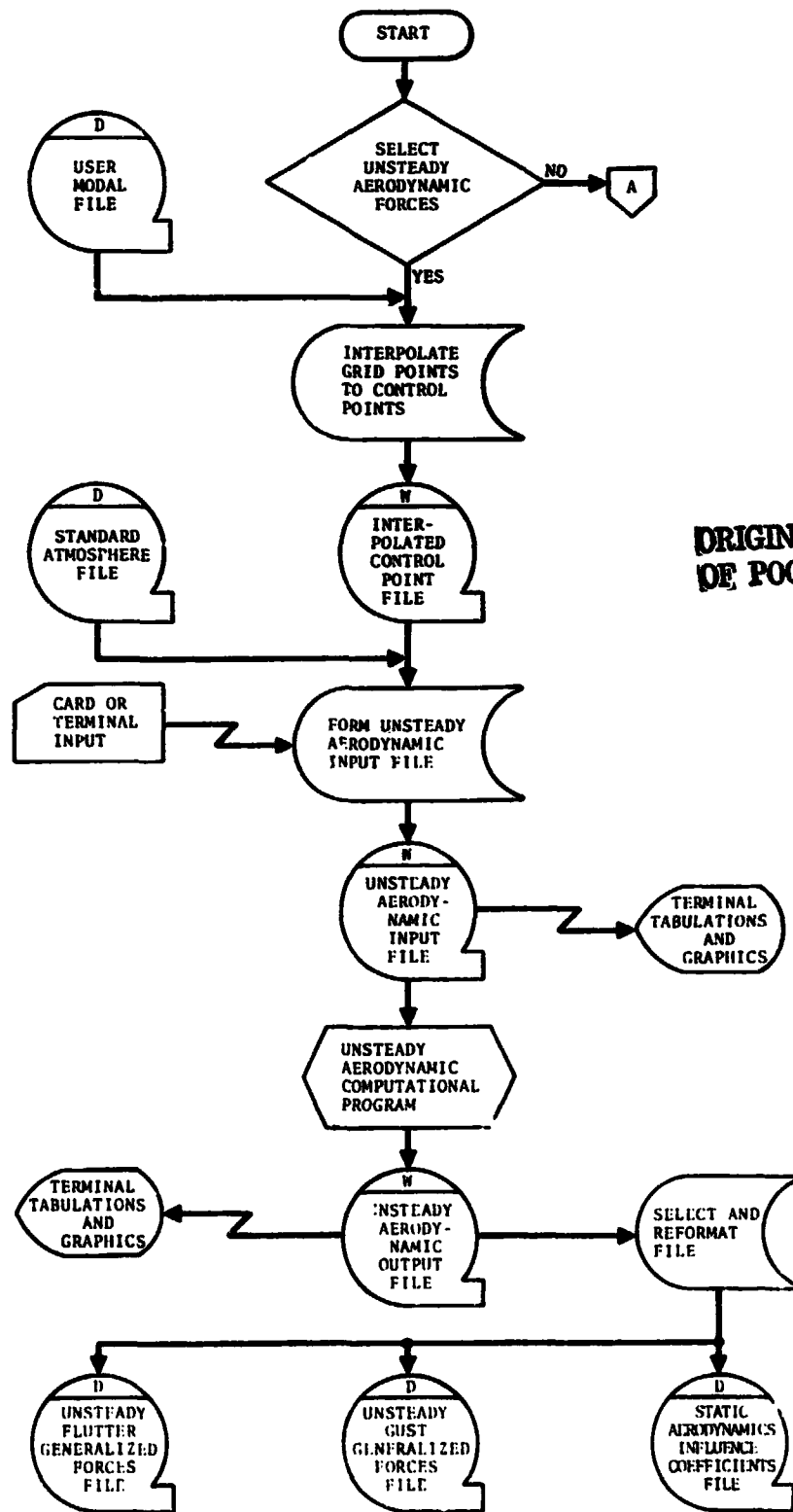

ORIGINAL PAGE IS OF POOR QUALITY

Figure 4.17-1. - Data flow diagram for Lifting Surface Flutter/ Unsteady Aerodynamic Forces.

LIFTING SURFACE FLUTTER

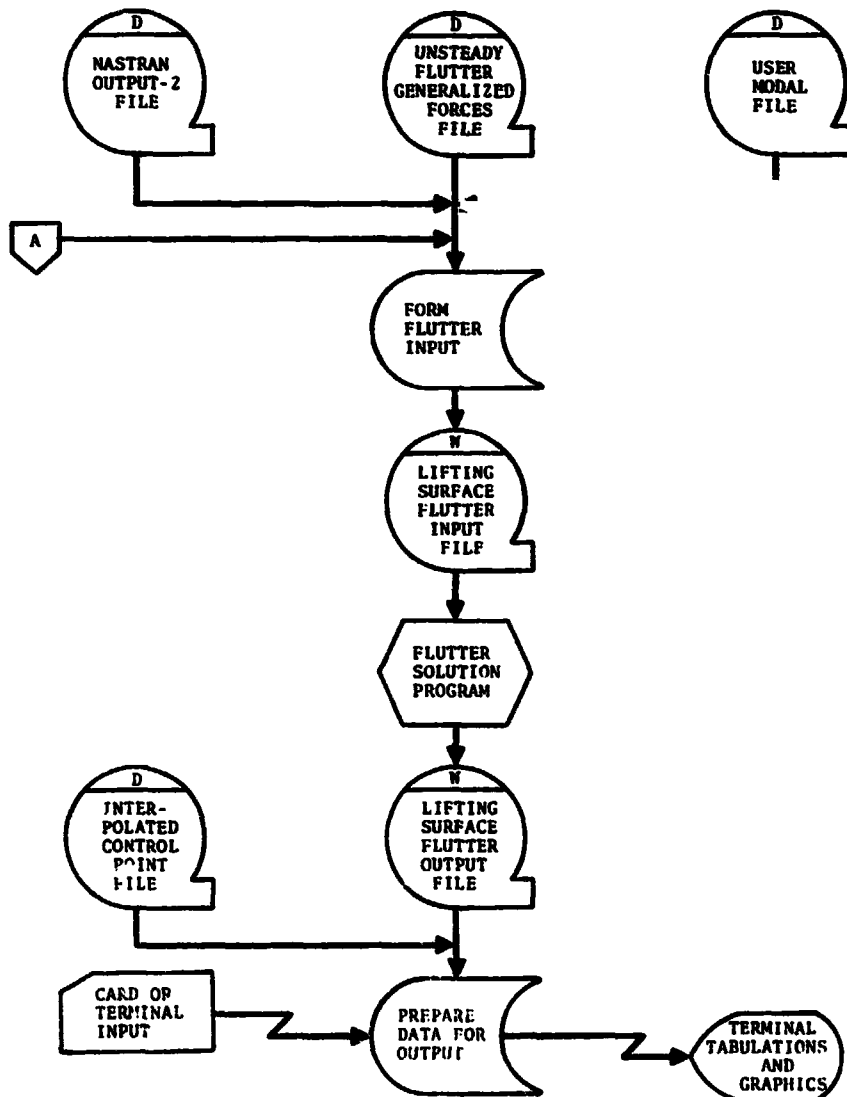

Figure 4.17-1. — Data flow diagram for Lifting Surface Flutter/Unsteady Aerodynamic Forces (concluded).

DOWNWASH DISTRIBUTION

TITLE _____

MACH NO. _____ ALTITUDE _____ REDUCED FREQ. _____

CONTROL POINT NUMBER	DOWNWASH		CONTROL POINT NUMBER	DOWNWASH	
	REAL	IMAGINARY		REAL	IMAGINARY
.
.
.

Figure 4.17-2. - Example of downwash distribution tabulation format.

UNSTEADY AERODYNAMIC INFLUENCE COEFFICIENTS

TITLE _____

MACH NO. _____ ALTITUDE _____ REDUCED FREQ. _____

CONTROL POINT COLUMN NUMBER _____

CONTROL POINT NUMBER	COEFFICIENT		CONTROL POINT NUMBER	COEFFICIENT	
	REAL	IMAGINARY		REAL	IMAGINARY
.
.
.

Figure 4.17-3. — Example of unsteady aerodynamic influence coefficients tabulation format.

PRESSURE DISTRIBUTION

TITLE _____

MACH NO. _____ ALTITUDE _____ REDUCED FREQ. _____

CONTROL POINT NUMBER	PRESSURE		CONTROL POINT NUMBER	PRESSURE	
	REAL	IMAGINARY		REAL	IMAGINARY
.
.
.

Figure 4.17-4. - Example of pressure distribution tabulation format.

GENERALIZED FORCES

TITLE _____

MACH NO. _____ ALTITUDE _____ REDUCED FREQ. _____

MODE NO. _____

CONTROL POINT NUMBER	GEN. FORCE		CONTROL POINT NUMBER	GEN. FORCE	
	REAL	IMAGINARY		REAL	IMAGINARY
.
.
.

Figure 4.17-5. - Example of generalized forces tabulation format.

AREA MATRIX

TITLE _____

MACH NO. _____ ALTITUDE _____ REDUCED FREQ. _____

CONTROL POINT COLUMN NO. _____

CONTROL POINT NUMBER	FORCE TERM	MOMENT TERM	CONTROL POINT NUMBER	FORCE TERM	MOMENT TERM
.
.
.

Figure 4.17-6. - Example of area matrix tabulation format.

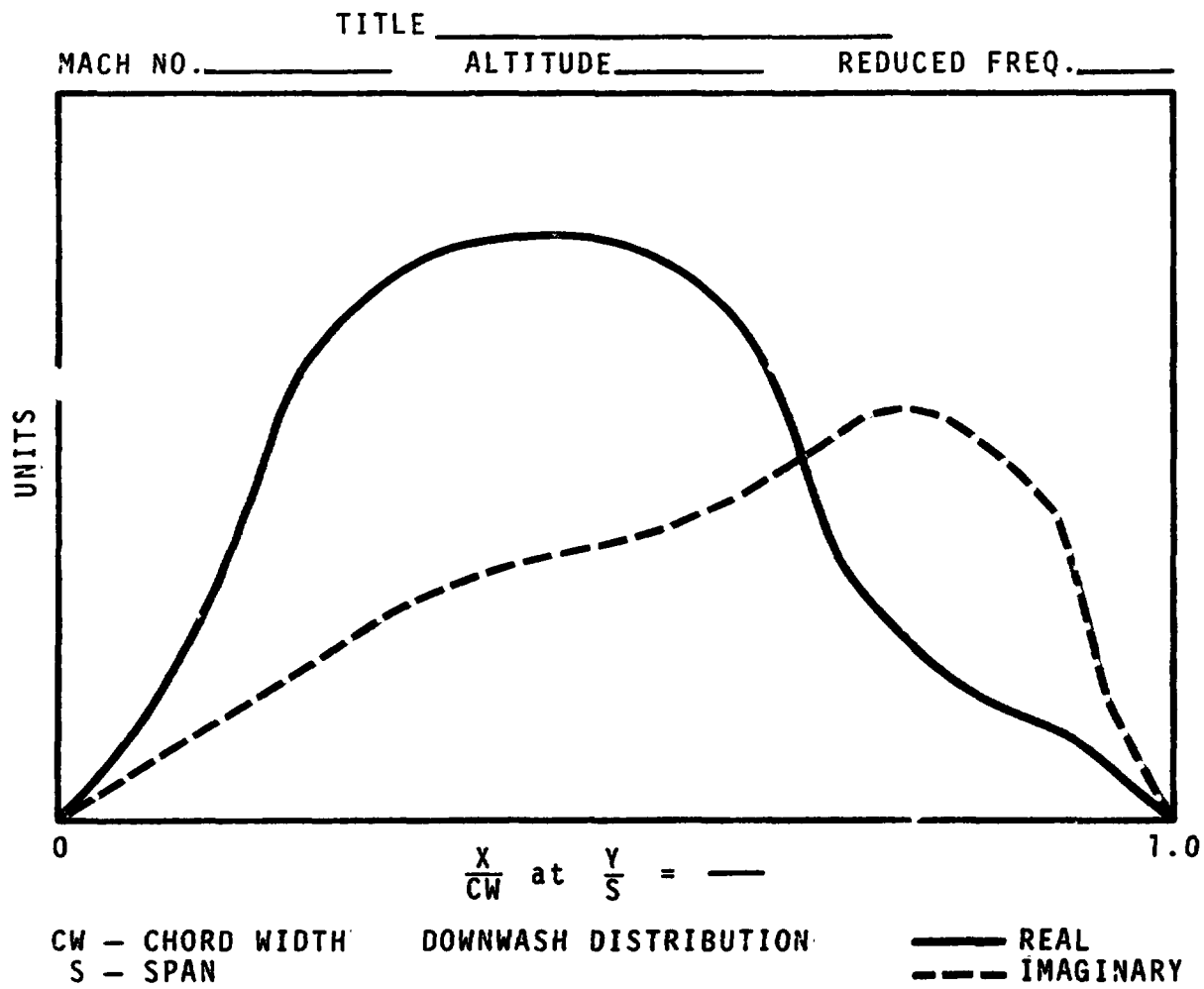

Figure 4.17-7. - Example of chordwise plot.

TITLE _____				
ALTITUDE _____		MACH NO. ____		
REDUCED FREQUENCY	RECIPROCAL REDUCED FREQUENCY	VELOCITY	DAMPING	FREQUENCY
.
.
.

Figure 4.17-8. - Format for tabulation of flutter solution data.

TITLE _____

MACH NO. _____ FLUTTER VELOCITY _____
 ALTITUDE _____ FLUTTER FREQ. _____
 REDUCED FREQ. _____ FLUTTER DAMPING _____
 MODE NO. _____

GRID POINT	DISPLACEMENT		GRID POINT	DISPLACEMENT	
	REAL	IMAGINARY		REAL	IMAGINARY
.
.
.

Figure 4.17-9. - Example of flutter mode shape data.

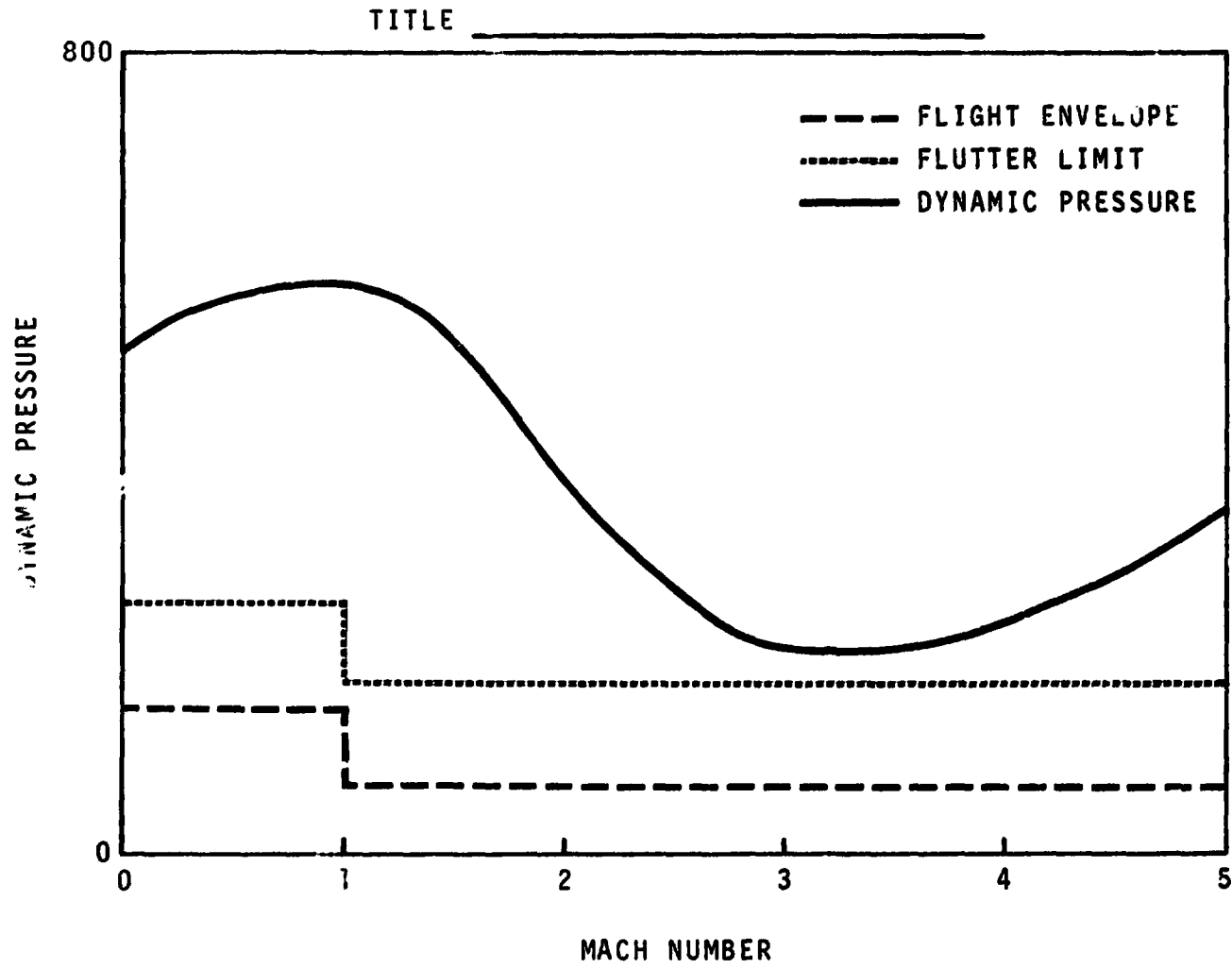

Figure 4.17-10. - Example of Mach number versus dynamic pressure plot.

4.18 LOAD COEFFICIENT GENERATOR

4.18.1 PURPOSE

This function will provide the means of preparing the input data for the Load Coefficient Generator Program and executing a demand version of this program to output the Load Coefficient Data File. The user will be aided in this preparation through menus, tabulations, graphical displays, and data editing capabilities. This function will also allow the user to create and/or edit FORTRAN NAMELIST input for a batch run. The user will be able to designate the names of input and output files and to start the batch program without exiting ISAS. Figure 4.18-1 is a data flow diagram of the Load Coefficient Generator function.

4.18.2 INPUT

The following files may be required as input.

- User Model File
- User Modal File
- Model Weight File
- Running Weight File

The Mass/Grid/Modal File will be created and used in this function as discussed in the Load Coefficient Demand Calculation section. Additionally, the batch Load Coefficient Generator Program will require a NAMELIST data file which will be created and edited in this function.

4.18.3 PROCESSING

The user will have the option of generating the Load Coefficient Data File either by starting the batch Load Coefficient Generator or entirely through a demand process. These two methods are discussed separately.

4.18.3.1 Preparing and Executing Batch Runs

If the user chooses the batch option, he will have the following capabilities for preparing and starting the batch run:

1. The user will be able to create and edit a card image NAME-LIST data file (or update a previously created one) for input to the batch program.
2. The user will be able to specify the following program input by name: the User Modal File, the User Model File, and/or the Model Weight File.
3. The user will be able to specify a mass storage file as the output Load Coefficient Data File.
4. The user will be able to start the batch run without exiting ISAS.

4.18.3.2 Preparing and Executing Demand Runs

If the user chooses the demand option, he will first be asked if the model will be input from the User Modal File. If the answer is yes, the User Modal File will be used to create the Mass/Grid/Modal File. The user will input the User Modal File name and a name for the Mass/Grid/Modal File, which will be created without further user interaction. The User Modal File is assumed to contain only one set of modes.

If the model will not be input from the User Modal File, the user will answer no and will create the Mass/Grid/Modal File using the following procedures. The user will be asked if he wishes to reduce the grid point representation of the substructures of the User Model File. If so, the user will have the following capabilities for redefining the grid point representation of the substructures:

1. The user will be able to graphically display and rotate the model in order to ensure its accuracy and make judgements on how to reduce it to a "beam model."

2. The user will be able to superimpose the grid point number upon the model generated by procedure 1.
3. The capability to display (in tabular form) the three-dimensional coordinates of any specified grid point set will be provided. The user will be able to define this set through the keyboard or graphical entry.
4. When the user has defined and approved the set, the points will automatically be defined as new grid points, whose coordinates and ID will be put in either manually or graphically.

Next, the effective mass matrix will be calculated for each new grid point as follows:

1. A geometry matrix $[G]$ will be developed for each point in each set relative to the new grid point.

$$[G_i] = \begin{bmatrix} 1 & 0 & 0 & 0 & 0 & 0 \\ 0 & 1 & 0 & 0 & 0 & 0 \\ 0 & 0 & 1 & 0 & 0 & 0 \\ 0 & -\Delta Z & \Delta Y & 1 & 0 & 0 \\ \Delta Z & 0 & -\Delta X & 0 & 1 & 0 \\ -\Delta Y & \Delta X & 0 & 0 & 0 & 1 \end{bmatrix}_i$$

where the Δ values will be the locations of the points relative to the new grid point.

2. The operation $[G]_i \cdot [M]_i \cdot [G]_i^T$ will be performed to transform the contribution of each mass point in the set to obtain the mass contribution of each point to the new grid point. ($[M]$ will come from the Model Weight File.) The resulting matrices will be summed algebraically for each set.

At this point, a reduced model on a new User Model File and an associated mass matrix on a new Model Weight File should exist.

However, if the Model Weight File is not available, the model will simply be reduced by defining the new grids and the associated sets that they represent and by retaining only these new grid points and any old ones not specifically reduced. No new Model Weight File will be output in this case.

4.18.3.3 Running Weights

4.18.3.3.1 Running Weights File

This file is described in detail in the Model Weight File Generator section. However, a brief description here is helpful. This file will contain both lumped and distributed weight data along three reference axes. It is assumed for loads coefficient purposes that the reference axes will be made to coincide with those used to calculate loads. If not, this must be corrected in the Model Weight File Generator function before creating the file. The user will be cautioned via a message on the screen that this function assumes that the axes coincide. The following is an example of what the file might contain for one axis.

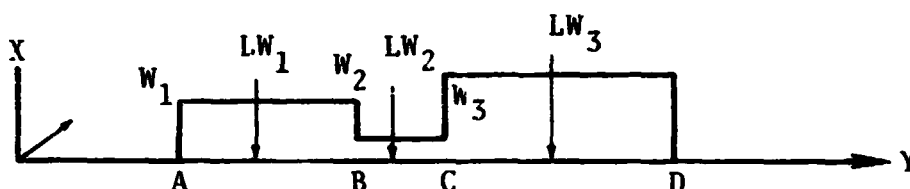

The weight distribution will be identified completely on the file by the Y-axis; points A, B, C, and D; and the running weights W_1 , W_2 , and W_3 . The lumped weights will be identified by their magnitudes LW_1 , LW_2 , and LW_3 and their points of application X_1 , Y_1 , Z_1 , etc.

4.18.3.3.2 Running Weights Calculation

The user will be asked if he wishes to have the loads coefficients calculated from a Running Weight File. If not, this section is skipped. Otherwise, the Running Weight File will be used to create a Model Weight File as follows.

First, the user will be asked to supply the name of the Running Weight File and a name for the output Model Weight File. The distribution will be displayed along the X-axis, and the user will be asked to input breakpoints for integration purposes. This procedure will be repeated for the Y- and Z-axes.

When integrating the running weights, the user will have the option of including calculation of the mass moment of inertia. If he chooses to include it, procedure 1 below is followed. If not, procedure 2 is followed.

1. The program will first display a message stating that the mass distribution of each segment is assumed to be a homogeneous right circular cylinder of radius R . Following this message, a tabular listing of the segment numbers and the breakpoints will be displayed, and the user will be asked to input R for each segment.

Thus for each segment i of a particular axis (X, Y, or Z), the dimensions of a right circular cylinder will be defined. For example, when working on a distributed mass segment along the X-axis, the distribution will look like

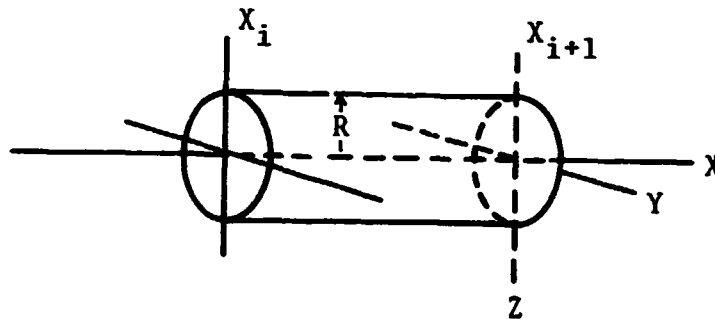

The products of the integration will be a diagonal matrix for each segment defining the lumped weights and inertias.

a. Distribution along X-axis (constant Y and Z)

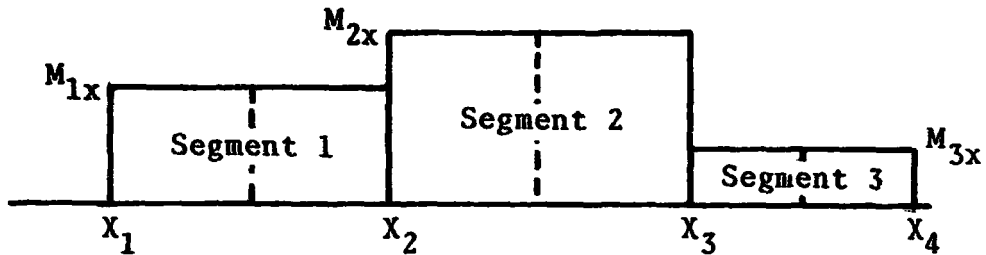

The integration will be done such that the masses are lumped at the breakpoints X_1, X_2, \dots, X_{n-1} and mass moments of inertia are calculated at these points.

The first step will be to calculate the mass of each segment:

$$M_1 = M_{1x} |X_2 - X_1|$$

$$\vdots$$

$$M_i = M_{ix} |X_{i+1} - X_i|$$

The masses are to be distributed at the breakpoints as follows:

$$M_x = M_y = M_z \text{ at breakpoint 1} = \frac{M_1}{2}$$

(at coordinates X_1, Y, Z)

$$M_x = M_y = M_z \text{ at breakpoint 2} = \frac{M_1}{2} + \frac{M_2}{2}$$

(at coordinates X_2, Y, Z)

$$M_x = M_y = M_z \text{ at breakpoint } i = \frac{M_{i-1}}{2} + \frac{M_i}{2}$$

(at coordinates X_i, Y, Z)

$$M_x = M_y = M_z \text{ at last breakpoint } i + 1 = \frac{M_1}{2}$$

(at coordinates X_{i+1}, Y, Z)

The next step will be to calculate the moments of inertia for one half of each segment about its end point:

$$I_{xx} \text{ of } 1/2 \text{ of segment } i = \frac{M_i R_i^2}{4}$$

The distribution of I_{xx} at each breakpoint will be:

$$I_{xx} \text{ at breakpoint } 1 = \frac{M_1 R_1^2}{4}$$

$$I_{xx} \text{ at breakpoint } 2 = \frac{M_1 R_1^2}{4} + \frac{M_2 R_2^2}{4}$$

$$I_{xx} \text{ at breakpoint } i = \frac{M_{i-1} R_{i-1}^2}{4} + \frac{M_i R_i^2}{4}$$

$$I_{xx} \text{ at final breakpoint } (i + 1) = \frac{M_{i-1} R_{i-1}^2}{4}$$

I_{yy} and I_{zz} of one half of segment i at its end point will be:

$$I_{yy}\left(\frac{1}{2} \text{ seg } i\right) = I_{zz}\left(\frac{1}{2} \text{ seg } i\right) = \frac{M_i}{24} \left[3R_i^2 + (X_{i+1} - X_i)^2 \right]$$

Therefore the distribution of I_{yy} and I_{zz} at each breakpoint will be:

$$I_{yy} = I_{zz} \text{ at breakpoint } 1 = I_{yy}\left(\frac{1}{2} \text{ seg } 1\right)$$

The masses are to be distributed at the breakpoints as follows:

$$M_x = M_y = M_z \text{ at breakpoint } 1 = \frac{M_1}{2}$$

(at coordinates X, Y₁, Z)

$$M_x = M_y = M_z \text{ at breakpoint } 2 = \frac{M_1}{2} + \frac{M_2}{2}$$

(at coordinates X, Y₂, Z)

$$M_x = M_y = M_z \text{ at breakpoint } i = \frac{M_{i-1}}{2} + \frac{M_i}{2}$$

(at coordinates X, Y_i, Z)

$$M_x = M_y = M_z \text{ at last breakpoint } i + 1 = \frac{M_i}{2}$$

(at coordinates X, Y_{i+1}, Z)

The next step will be to calculate the moments of inertia for one half of each segment about its end point:

$$I_{yy} \text{ of } 1/2 \text{ segment } i = \frac{M_i R_i^2}{4}$$

Therefore, the distribution of I_{yy} at each breakpoint will be:

$$I_{yy} \text{ at breakpoint } 1 = \frac{M_1 R_1^2}{4}$$

$$I_{yy} \text{ at breakpoint 2} = \frac{M_1 R_1^2}{4} + \frac{M_2 R_2^2}{4}$$

$$I_{yy} \text{ at breakpoint } i = \frac{M_{i-1} R_{i-1}^2}{4} + \frac{M_i R_i^2}{4}$$

$$I_{yy} \text{ at last breakpoint } i + 1 = \frac{M_{i-1} R_{i-1}^2}{4}$$

I_{xx} and I_{zz} of one half of segment i at its end point will be:

$$I_{xx}\left(\frac{1}{2} \text{ seg } i\right) = I_{zz}\left(\frac{1}{2} \text{ seg } i\right) = \frac{M_i}{24} \left[3R_i^2 + (Y_{i+1} - Y_i)^2 \right]$$

Therefore, the distribution of I_{xx} and I_{zz} at each breakpoint will be:

$$I_{xx} = I_{zz} \text{ at breakpoint 1} = I_{xx}\left(\frac{1}{2} \text{ seg } 1\right)$$

$$I_{xx} = I_{zz} \text{ at breakpoint 2} = I_{xx}\left(\frac{1}{2} \text{ seg } 1\right) + I_{xx}\left(\frac{1}{2} \text{ seg } 2\right)$$

$$I_{xx} = I_{zz} \text{ at breakpoint } i = I_{xx}\left(\frac{1}{2} \text{ seg } i - 1\right) + I_{xx}\left(\frac{1}{2} \text{ seg } i\right)$$

$$I_{xx} = I_{zz} \text{ at last breakpoint } i + 1 = I_{xx}\left(\frac{1}{2} \text{ seg } i\right)$$

c. Distribution along Z-axis

The procedure is identical to b except that all Y's and Z's should be interchanged in the equations.

2. Following a "no" reply to the question concerning mass moments of inertia, the calculation of M_x , M_y , and M_z can proceed directly as in procedure 1. I_{xx} , I_{yy} , and I_{zz} will be set to zero and the matrix will be set up as before with the lumped weight located the same way as in procedure 1.

After these procedures for lumping the weights are completed, a menu will ask the user to input a factor to scale masses and inertias with a default value of 1.0.

4.18.3.4 Mass/Grid/Modal File Creation

At this point, data from the Model Weight and User Model Files will be reformatted into the Mass/Grid/Modal File. This file could also be automatically created from a User Modal File in the first step of demand processing if the user so chooses. In this case, the modal portion of the Mass/Grid/Modal File will have valid data entries.

The grid ID's from the Model Weight File will be stored under the names NODES (see file contents page A-115). The corresponding X, Y, and Z coordinates from the User Model File will be stored under the name XYZ. The node description from the User Model File will be stored under NAME. The IDXYZ array will be constructed so that it consists of integers whose last digit will be from 1 to 6, indicating the degree of freedom represented by a nonzero column in the associated individual mass matrix. The leading digits will be the same as the node number. The IDXYZ array will be in one-to-one correspondence with the nonzero columns in the full mass matrix M which is now described.

The full mass matrix array M will be set up as follows. The Model Weight File can be visualized as sets of 6×6 matrices,

one for each node. To form M , they will be arranged in the following manner:

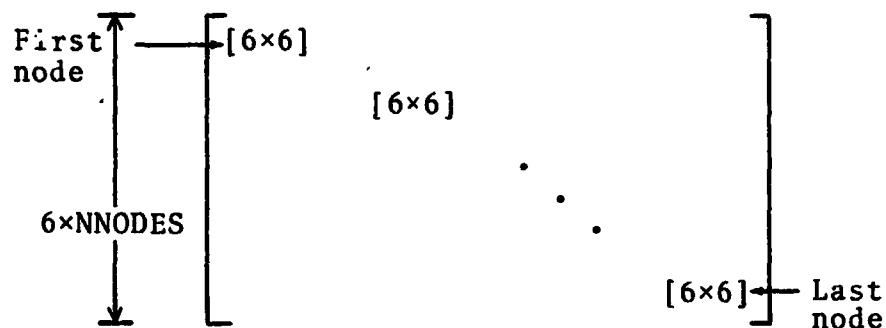

(This matrix could be constructed from a User Modal File, in which case there might be off-diagonal elements.) At this point, there will exist a full mass matrix M , whose columns are identified by distinct IDXYZ elements and whose dimensions are $NDF \times NDF$, where NDF is the number of degrees of freedom in the mass model.

Since grid, mass, and modal data will be on different sources (either User Model File and Model Weight File or User Modal File), they should be collected onto one file to be used in computing loads coefficients. The file will contain:

1. NNODES - Number of node points in the model.
2. NDF - Total number of degrees of freedom in the model.
3. TITLE - Description of model.
4. NMODES - Number of modes copied from User Modal File.
5. NODES - Either the grid point number from the User Model File and a corresponding grid ID from the Model Weight File or the NODEID from the User Modal File.
6. NAME - Word description of each node.

7. XYZ – The three Cartesian coordinates of each node obtained from the User Model File or from the XMAT matrix on the User Modal File.
8. IDXYZ – The degrees-of-freedom ID numbers for each degree of freedom. On the User Modal File, this is identified as IDXYZ. (It must be set up in the Create Mass/Grid/Modal File subfunction if the source of the mass data is the Model Weight File.)
9. M – Full mass matrix retrieved from the Model Weight File as directed in the reformat subfunction or from the User Modal File.
10. PHI – The modal matrix identified as such on the User Modal File.

4.18.3.5 Select and Edit Data Subfunction

This subfunction will enable the user to edit only the Mass/Grid/Modal File in order to specify which data are to be used to calculate the loads coefficients. The user will supply the Mass/Grid/Modal File name. This file will contain the complete set of masses to be used in the calculations, their respective ID numbers, and their Cartesian coordinates.

In editing, the display for each node will consist of the node ID, Cartesian coordinates, node description, and a 6×6 mass matrix. The user will have the option of editing the data serially or specifying a node ID. The user will be able to add, delete, or change any of the foregoing data. The user will also have the capability of naming a blank file and inputting the entire data set manually, but in general, the initial data will come either from the User Model File and Model Weight File or from the User Modal File.

4.18.3.6 Load Coefficient Demand Calculation

The first step in this subfunction will be to graphically display the node point model and permit the user to input new stations by specifying the coordinates. Next, the user will be asked if any data are to be input via an external data element. If so, the user will supply the name of the element on file. These data could include all or part of the following:

1. Coordinates of the stations for which load coefficients will be generated and their vehicle component identifiers.
2. Data defining which nodes are to be included in the loads coefficients calculations for each station
3. Flags denoting symmetric and asymmetric modes
4. A flag to cause a calculation of the center of gravity location
5. Coordinates of the reference point
6. Coordinates of the forward and aft fittings for the calculation of link load coefficients
7. Data defining the node points to be used in calculating link load coefficients
8. Data to group the node points of major components which are to be linked together via the link logic
9. Data specifying which modes are to be used in calculating loads coefficients
10. Data specifying a rigid body diagonal mass matrix and corresponding Cartesian coordinates

This subfunction will provide the capability of listing and editing the preceding data.

Next, the user will be asked if any data are to be input from the terminal. If so, the current coordinates and vehicle identifiers for the load stations (item 1 in the preceding list) will be displayed and the user will decide to accept or change them. The user will also be able to add more load stations at this time.

The user will be asked to input data defining which nodes are to be included in calculating load coefficients at each station (item 2). Corresponding to load station i there should be an array similar to the following:

$$\text{LDNODE}(1,i) = \text{NODES}_{\text{BEGIN1}}, \text{NODES}_{\text{END1}}, \text{NODES}_{\text{BEGIN2}}, \\ \text{NODES}_{\text{END2}}, \dots, \text{NODES}_{\text{BEGINN}}, \text{NODES}_{\text{ENDN}} .$$

Each pair of $\text{NODES}_{\text{BEGIN}}$ and $\text{NODES}_{\text{END}}$ words will include all node points from $\text{NODES}_{\text{BEGIN}}$ to $\text{NODES}_{\text{END}}$ in the calculations for load station i . The nodes will be read, without changing the order, from the NODEID array, which may not necessarily be in numerical order. For example, if nodes 1, 17, 18, 22, and 6 are to be included in the calculation of loads at station 3 and the NODEID array is 2, 1, 3, 17, 18, 22, 5, 6, then $\text{LDNODE}(1,3)$ should be 1, 1, 17, 22, 6, 6.

The menu for inputting the LDNODE array should print out the coordinates of the station, the vehicle component, and the begin and end node ID pairs. The menu should then allow for additions or modifications.

At this time the user must specify whether the current set of nodes is symmetric, asymmetric, or complete. The user will

then be asked whether or not the vehicle's center of gravity is to be calculated. Next, the user will be given the coordinates of the reference point and the option to modify them. Likewise, the coordinates of the three forward and three aft fittings will be displayed with the option to modify them. These coordinates will correspond to the following attachment points.

1. Orbiter-external tank (ET)
2. Left solid rocket booster-external tank (SRB-ET)
3. Right SRB-ET

The next display will consist of the set of node points required for calculation of loads at each of the three sets of fittings.

The array NODFIT will function in the same manner as the LDNODE array. For example, the NODFIT array for the Orbiter-ET attachment will be $NODFIT(1,1) = NODES_{BEGIN1}, NODES_{END1}, \dots, NODES_{BEGINN}, NODES_{ENDN}$, and for the left SRB-ET it will be $NODFIT(1,2) = NODES_{BEGIN1}, NODES_{END1}, \dots, NODES_{BEGINM}, NODES_{ENDM}$. The user will be able to accept, reject, modify, or add to these values with the aid of a menu specifying the node pairs (beginning and ending) and the fitting number.

Primarily due to Space Shuttle requirements, logic must be included in this function to allow calculation of load coefficients for separate bodies linked together as well as appendages like wings and tails. Therefore, the next step will be to ask for a data array (LOADID) specifying which body or appendage is being calculated for each load. Currently, seven choices will exist.

1. Orbiter fuselage
2. Left wing
3. Right wing

4. Vertical tail
5. External tank
6. Left solid rocket
7. Right solid rocket

This notation is for convenience and will be changeable for other configurations. The LOADID array will be an array of integers, one for each load station, e.g., LOADID = 1, 1, 1, 4, 4, 4, 2, 2, 3, 3, etc. The current values of the LOADID array will be displayed, and the user will be able to accept, modify, or add to them.

The next set of data will be used to group the node points by major components which are linked together via the link logic. The node points will be grouped by hundreds; for example, node ID's 200 to 299 will be in the third group. The major components will be the Orbiter, left solid rocket motor, right solid rocket motor, and external tank. A menu will display the components and their groups of node ID's and allow the user to accept or modify them.

The next step will specify what modes are to be used in calculating the loads coefficients. This subfunction will be programmed to automatically bypass this step if there are no modes on the Mass/Grid/Modal File. The user will be able to specify that all modes are to be used; he may individually select them or he may use the first N modes, where N is input by the user.

4.18.3.7 Load Coefficient Matrix Calculation

The following matrix calculations are to be performed. The first matrix that will be calculated is called the geometry (G) matrix. This matrix, when multiplied by the reference point acceleration,

will give the acceleration for each degree of freedom that exists in the model being analyzed. The G-matrix will have the following appearance:

$$G = \begin{bmatrix} 1 & 0 & 0 & 0 & 0 & 0 \\ 0 & 1 & 0 & 0 & 0 & 0 \\ 0 & 0 & 1 & 0 & 0 & 0 \\ 0 & Z_{R1} & Y_{1R} & 1 & 0 & 0 \\ Z_{1R} & 0 & X_{R1} & 0 & 1 & 0 \\ Y_{R1} & X_{1R} & 0 & 0 & 0 & 1 \\ \dots & & & & & \end{bmatrix}$$

where

$$X_{1R} = X_1 - X_R$$

The numerical subscript denotes the node number coordinate, and the R denotes the reference point coordinate. The Y and Z subscripts have similar definitions.

The G-matrix will be constructed only for those degrees of freedom that exist in the math model being used, so all six columns per node point may not exist for all node points. The six columns shown above in the G-matrix correspond to the X, Y, and Z translational and X, Y, and Z rotational degrees of freedom. The G-matrix is $6 \times \text{NDF}$.

Next, if the model is symmetric, the following operation will be performed:

$$[G] = [\text{MOD1}] [G]$$

where

$$[\text{MOD1}] = \begin{bmatrix} 2.0 \\ 0.0 \\ 2.0 \\ 0.0 \\ 2.0 \\ 0.0 \end{bmatrix}$$

If the model is asymmetric, the operation will be:

$$[G] = [\text{MOD2}] [G]$$

where

$$[\text{MOD2}] = \begin{bmatrix} 0.0 \\ 2.0 \\ 0.0 \\ 2.0 \\ 0.0 \\ 2.0 \end{bmatrix}$$

The GTM matrix will be calculated:

$$[\text{GTM}] = [G] [M]$$

where M is the full mass matrix of size NDF × NDF.

These two matrices are to be used to obtain the 6 × 6 vehicle total mass and inertia matrix, as follows:

$$[RM] = [G] [GTM]^T$$

At this point, if the user has set the appropriate flag, the center of gravity will be calculated in the following manner:

$$[RM] = [RM] [CGFACT]$$

For SYM = f and ANTI = f,

$$X'_{CG} = \frac{RM(2,6)}{RM(1,1)} + X_{CG}$$

$$Y'_{CG} = \frac{RM(3,4)}{RM(2,2)} + Y_{CG}$$

$$Z'_{CG} = \frac{RM(1,5)}{RM(3,3)} + Z_{CG}$$

For SYM = T or ANTI = T,

$$X'_{CG} = -\frac{RM(5,3)}{RM(3,3)} + X_{CG}$$

$$Y'_{CG} = \frac{RM(4,3)}{RM(3,3)} + Y_{CG}$$

$$Z'_{CG} = \frac{RM(5,1)}{RM(1,1)} + Z_{CG}$$

where, if SYM = T and ANTI = F,

$$\text{CGFACT} = \begin{bmatrix} 1.0 \\ 0.0 \\ 1.0 \\ 0.0 \\ 1.0 \\ 0.0 \end{bmatrix}$$

If ANTI = T,

$$\text{CGFACT} = \begin{bmatrix} 0.0 \\ 1.0 \\ 0.0 \\ 1.0 \\ 0.0 \\ 1.0 \end{bmatrix}$$

If ANTI = SYM = F,

$$\text{CGFACT} = \begin{bmatrix} 1.0 \\ 1.0 \\ 1.0 \\ 1.0 \\ 1.0 \\ 1.0 \end{bmatrix}$$

if the calculated center of gravity is not the same as the reference point, the reference point will be set equal to the

center of gravity. Execution will then return to the first step, where another G-matrix will be calculated and the process repeated with the new reference point. This step is to be repeated a maximum of 10 times or the difference between the new and old calculated C_G location is less than $1.0E-8$. The RM-matrix will then be displayed and labeled as the Vehicle Total Mass Matrix. Next, the multiplication of the full mass matrix by the modal matrix will be performed:

$$[M\phi] = [M][\phi]$$

The following calculations will be performed for each station at which load coefficients are to be calculated.

The transformation matrix T_R will be calculated as:

$$T_R = \begin{bmatrix} 1 & 0 & 0 & 0 & 0 & 0 \\ 0 & 1 & 0 & 0 & 0 & 0 \\ 0 & 0 & 1 & 0 & 0 & 0 \\ 0 & -Z_{RL} & Y_{RL} & 1 & 0 & 0 \\ Z_{RL} & 0 & -X_{RL} & 0 & 1 & 0 \\ -Y_{RL} & X_{RL} & 0 & 0 & 0 & 1 \end{bmatrix}$$

where

$$X_{RL} = X_R - X_L$$

X_R - X-coordinate of the reference point

X_L - X-coordinate of the load station

Y_{RL} and Z_{RL} are defined in a similar manner.

After calculating T_R , the TEF-matrix will be generated:

$$[TEF] = [T_R] [G_L]$$

Next, the MTEF-matrix will be calculated, where

$$[MTEF] = -[TEF]$$

G_L is a reduced version of the G-matrix, where only the columns of the G-matrix that are to be included in calculating the loads are transferred from the G-matrix into the G_L -matrix. The MTEF-matrix is a required output matrix.

The RBLC and EBLC matrices will be calculated as

$$[RBLC] = [TEF][GTM]^T$$

$$[EBLC] = [TEF][M\phi]$$

and are required output matrices. In addition to these three matrices, load coefficients for the links that connect the Orbiter to the tank, etc., must be calculated.

The link loads coefficients will be calculated in the following manner. For each load station, the node ID number of the first node point being used to calculate link loads coefficients at that station will be checked to see which set of links is involved. For example, if the node ID is in the 300's group and the 300's group is assigned to the left SRB, the link set involved will be that for the left SRB. This check must be done to know which fitting coordinates are to be compared against the load stations. If the group is assigned to the tank, all three sets of fittings must be checked.

The results of this comparison of the X-coordinates will be one of the following three cases:

1. The load station is forward of the forward fitting.
2. The load station is between the two fittings.
3. The load station is aft of the aft fitting.

The results of this test will determine which parts of the LG-matrix (fig. 4.18-2) will be transferred to the LGA-matrix for calculation of link coefficients.

The LGA-matrix will be a zero matrix of the same dimensions (6×36) as the LG-matrix. If case 1 occurs, no part of LG will be transferred to LGA. If case 2 occurs, the 6×6 matrix representing the forward fitting of the component in question will be transferred to the same place in LGA. If case 3 occurs, both 6×6 matrices for the component will be transferred to LGA. If the component is the tank, the load station position will be compared separately with each of the three pairs of fittings, and by the same rules, between zero and six of the 6×6 submatrices will be transferred to LGA. LGA will then be multiplied as follows:

$$[LGA] = [LGA][MOD]$$

where, if the model is symmetric,

$$[MOD] = \begin{bmatrix} 2.0 \\ 0.0 \\ 2.0 \\ 0.0 \\ 2.0 \\ 0.0 \end{bmatrix}$$

If the model is asymmetric,

$$[\text{MOD}] = \begin{bmatrix} 0.0 \\ 2.0 \\ 0.0 \\ 2.0 \\ 0.0 \\ 2.0 \end{bmatrix}$$

In the full case (i.e., model is neither symmetric or asymmetric),

$$[\text{MOD}] = \begin{bmatrix} 1.0 \\ 1.0 \\ 1.0 \\ 1.0 \\ 1.0 \\ 1.0 \end{bmatrix}$$

Next, the calculation

$$[\text{LTEF}] = [\text{LGA}][\text{TR}]$$

will be performed, where

$$[\text{TR}] = \begin{bmatrix} 1 & 0 & 0 & 0 & 0 & 0 \\ 0 & 1 & 0 & 0 & 0 & 0 \\ 0 & 0 & 1 & 0 & 0 & 0 \\ 0 & -Z_{\text{RL}} & Y_{\text{RL}} & 0 & 0 & 0 \\ Z_{\text{RL}} & 0 & -X_{\text{RL}} & 0 & 1 & 0 \\ -Y_{\text{RL}} & X_{\text{RL}} & 0 & 0 & 0 & 1 \end{bmatrix}$$

where

$$X_{PL} = X_R - X_L$$

$$Y_{RL} = Y_R - Y_L$$

$$Z_{RL} = Z_R - Z_L$$

X_R - X-coordinate of the reference point

X_L - X-coordinate of the load station

Y_R , Y_L , Z_R , and Z_L are defined in a similar manner.

LTEF will be multiplied by -1 and referred to as the MLTEF-matrix. This will complete the link loads coefficients calculations.

4.18.4 OUTPUT

Output files will consist of the following:

- Load Coefficient Data File
- Mass/Grid/Modal File
- Load Coefficient NAMELIST Input Data File (for batch run input)

Additional output will consist of terminal tabulations, graphical displays, and menus, as described in the processing section. The user will have the capability of producing a tabular display of the data on the Load Coefficient Data File, whether created by the batch program or the demand program.

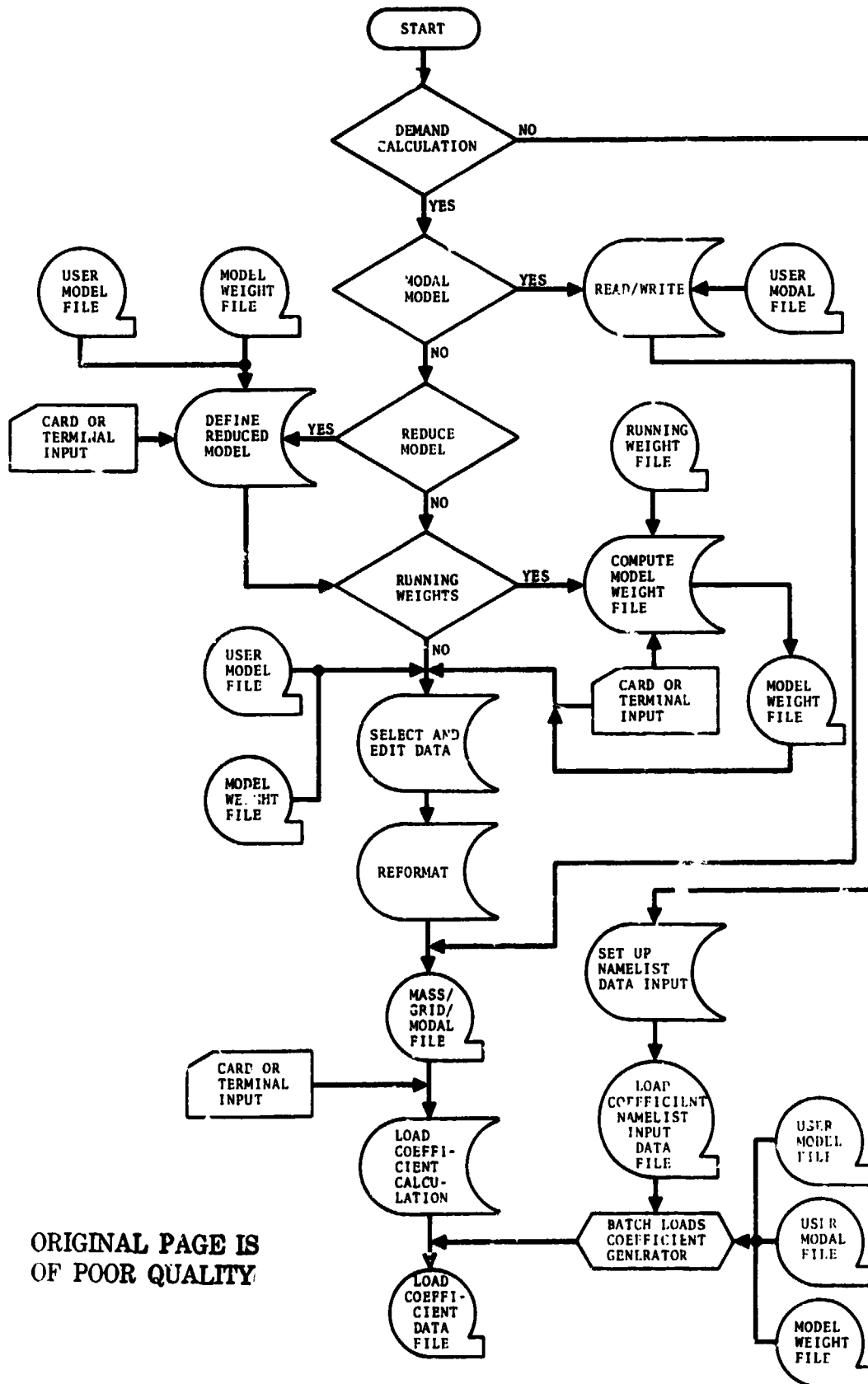

ORIGINAL PAGE IS
OF POOR QUALITY

Figure 4.18-1. -- Data flow diagram for Load Coefficient Generator.

[LG] =	1.0	0	0	0	0	0	FORWARD FITTING	ORBITER 11
	0	1.0	0	0	0	0		
	0	0	1.0	0	0	0		
	0	-ZDF	YDF	1.0	0	0		
	ZDF	0	-XDF	0	1.0	0		
	-YDF	XDF	0	0	0	1.0		
1.0	0	0	0	0	0	FORWARD FITTING	LEFT SRB-11	
0	1.0	0	0	0	0			
0	0	1.0	0	0	0			
0	-ZDF	YDF	1.0	0	0			
ZDF	0	-XDF	0	1.0	0			
-YDF	XDF	0	0	0	1.0			
1.0	0	0	0	0	0	AFT FITTING	RIGHT SRB-11	
0	1.0	0	0	0	0			
0	0	1.0	0	0	0			
0	-ZDF	YDF	1.0	0	0			
ZDF	0	-XDF	0	1.0	0			
YDF	XDF	0	0	0	1.0			
1.0	0	0	0	0	0	FORWARD FITTING	RIGHT SRB-11	
0	1.0	0	0	0	0			
0	0	1.0	0	0	0			
0	-ZDF	YDF	1.0	0	0			
ZDF	0	-XDF	0	1.0	0			
-YDF	XDF	0	0	0	1.0			
1.0	0	0	0	0	0	AF, FITTING	RIGHT SRB-11	
0	1.0	0	0	0	0			
0	0	1.0	0	0	0			
0	-ZDF	YDF	1.0	0	0			
-YDF	0	-XDF	0	1.0	0			
-YDF	XDF	0	0	0	1.0			

ORIGINAL PAGE IS
OF POOR QUALITY

where

$$XDF = X_{fit} - X_{ref}$$

$$YDF = Y_{fit} - Y_{ref}$$

$$ZDF = Z_{fit} - Z_{ref}$$

II = 1, orbiter - FT

II = 2, use left SRB 11

II = 3, use right SRB 11

FIGURE 4.18-2 - LG MATRIX FORMAT

4.19 MATERIAL DATA FILE GENERATOR

4.19.1 PURPOSE

This function will allow a user to input, edit, and display graphically a Material Data File. This file should be a central repository of all material-dependent properties, containing curves and tables for selected materials. Figure 4.19-1 is a data flow diagram for the Material Data File Generator.

4.19.2 INPUT

Two methods of input for this function should exist. Input through a card reader in a batch mode of operation should be available due to the large volume of curves and tables that might be required. However, direct input and editing will also be available. Due to the size and importance of this file, a file manager should be in charge of updating the file contents; the file should be secured and read only.

4.19.3 PROCESSING

Regardless of the method of input, it will be necessary for the user to input a title as the first input item for each curve or table. Each title should consist of the material identifier followed by a description of the input data, such as "aluminum 2024-T81 alpha vs. temperature." The program will check the file table of contents for the title. If it is already in the table of contents, then the user must specify a unique title or have the original data deleted from the file. If the input title is not found in the table of contents, it will be inserted in correct alphanumeric order and the curve or table will be added to the file. The material identifier should be input in the same format for all entries under that material. For example, all curves and tables for aluminum alloy 2024, heat treatment T81, should have a title beginning "aluminum 2024-T81."

When input is by cards or the keyboard, tabular data will be input by rows, including fields for row and column labels. Curve data will be input in terms of X and Y coordinates with a limit of 100 data points. Several curves having common axes will be allowed.

Curve input at the console can be accomplished by typing in X and Y values or by using the light pen. To use the light pen, a set of axes should be generated with limits set by the user. The light pen would then be used to select points on the curve. These points will be connected by a series of straight lines to form the curve.

The user should have the option of displaying on the screen all curve or tabular data stored on the file. To do this, he should first be able to display the table of contents or a portion of it on the screen. Using table 4.19-1 as an example, all titles would be listed if the entire table of contents is desired. The user could then select a curve or table to be displayed by typing in the line number. The user should also have the capability of displaying only a portion of the table of contents. For instance, again using table 4.19-1, he could specify the material "aluminum 2024" and have four titles printed. Alternately, he could specify a metal alloy plus heat treatment number, "aluminum 2024-T81," and have three titles printed.

Curve data can be displayed either as plots or tables. The user should be able to edit both curves and tables by interactively selecting items and inputting new values. With curves in plot form, the user may also type in a parameter and have its corresponding value computed by a linear interpolation routine and displayed on the screen. Table 4.19-2 and figure 4.19-2 are samples of types of tabular and curve data to be included in the Material Data File.

4.19.4 OUTPUT

Output for this function will consist of graphical and tabular displays at the remote terminal, hardcopy output of these displays, and a Material Data File. The Material Data File will contain all properties (structural, thermal, etc.) that are material dependent.

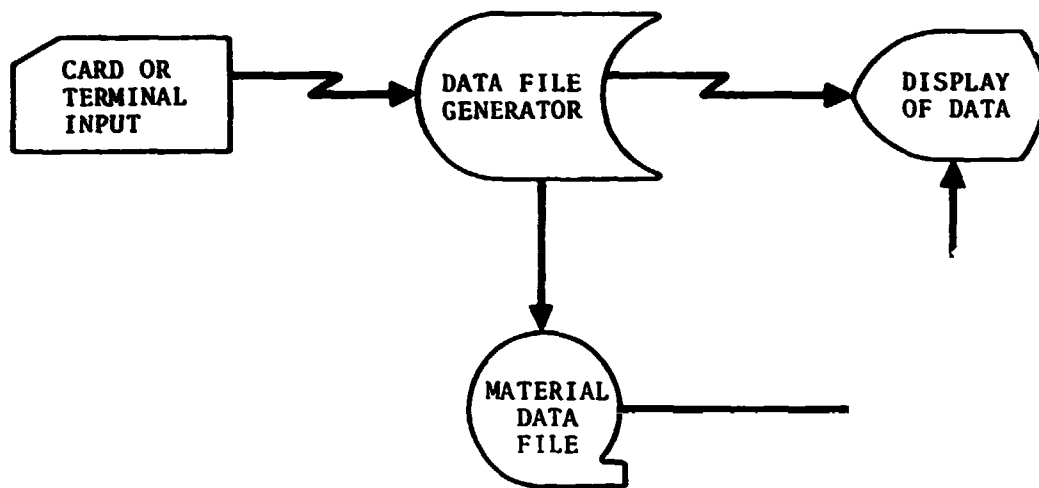
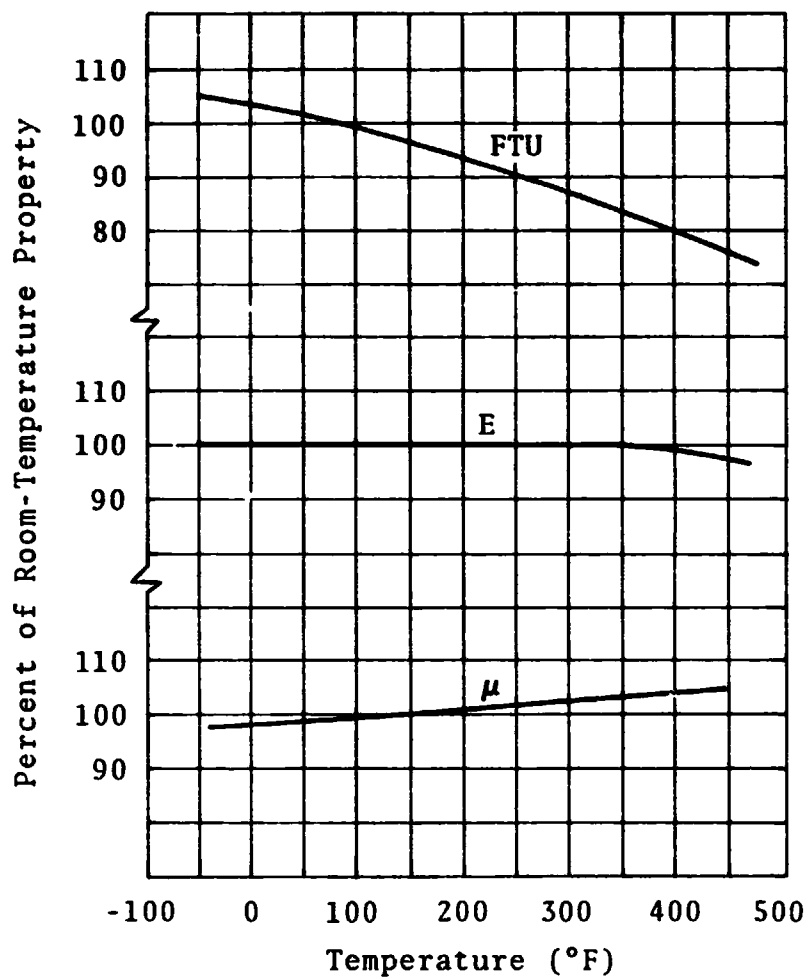

Figure 4.19-1. - Data flow diagram for Material Data File Generator.

PROPERTIES VERSUS TEMPERATURE
 BORON/EPOXY - [0] - LONGITUDINAL TENSION



where

FTU - Tensile ultimate strength

E - Tension modulus

μ - Poisson's ratio

Figure 4.19-2. -- Sample of curve data.

TABLE 4.19-1 – SAMPLE TABLE OF CONTENTS

MATERIAL DATA FILE	
TABLE OF CONTENTS	
<u>Line</u>	<u>Title</u>
1	Aluminum 2024-T81 tab data at r.t.
2	Aluminum 2024-T81 alpha vs. temperature
3	Aluminum 2024-T81 FTU vs. temperature
4	Aluminum 2024-T851 alpha vs. temperature
5	Aluminum 7075-T73 tab data at r.t.
6	Aluminum 7075-T73 alpha vs. temperature
7	Boron-Aluminum tab data at r.t.

TABLE 4.19-2. -- SAMPLE OF TABULAR DATA

Key Room-Temperature Properties

Boron/Aluminum - [0]

$$V_f = 0.50$$

Design Strengths	Symbol	Measurement
Longitudinal tensile ultimate	F _{TU}	160.0 ksi
Transverse tensile ultimate	FTU	16.0 ksi
Longitudinal compression ultimate	FCU	176.0 ksi
Transverse compression ultimate	FCU	23.0 ksi
In-plane shear ultimate	FSU	10.0 ksi
Interlaminar shear ultimate	FISU	18.3 ksi
Ultimate longitudinal strain	e _{TU}	5,000.0 μ in./in. 6,000.0
Ultimate transverse strain	ε _{TU}	6,000.0 μ in./in. 12,000.0
Elastic Properties	Symbol	Measurement
Longitudinal tension modulus	E	34.0 msi
Transverse tension modulus	E	20.0 msi
Longitudinal compression modulus	EC	30.0 msi
Transverse compression modulus	EC	19.0 msi
In-plane shear modulus	G	9.5 msi
Longitudinal Poisson's ratio	μ	0.23
Transverse Poisson's ratio	μ	0.17
Physical Constants	Symbol	Measurement
Density	ρ	0.098 lbs/in. ³
Longitudinal coefficient of thermal expansion	α	3.2 μ in./in./°F
Transverse coefficient of thermal expansion	α	10.6 μ in./in./°F

4.20 MOTION PICTURE GENERATOR

4.20.1 PURPOSE

This function will consist of two separate subfunctions. The first subfunction will provide the capability to have movie displays generated on the Adage CRT. Both two-dimensional and three-dimensional images must be supported by the subfunction. The second subfunction will generate SC-4060 microfilm of any display shown on the Adage CRT. Figure 4.20-1 shows the data flow.

4.20.2 MOVIE SUBFUNCTION

4.20.2.1 Input

The input to this subfunction will be a mass storage data file which describes the image for each increment over the movie span. No format of this file can be developed until the detailed design of the subfunction has been started.

4.20.2.2 Processing

This subfunction will read the input file and generate a series of images which correspond to the span increments. The period of time that each image is displayed must be controllable by the user. The user will have the capability to speed up, slow down, and freeze the apparent motion. The user must also have the capability to change the position, orientation, and size of the displayed image.

This subfunction will not provide any capability to edit the data being displayed. This capability will be provided by the functions which create the input file.

4.20.2.3 Output

The only output from this subfunction will be the two-dimensional or three-dimensional movies described in the preceding sections.

4.20.3 SC-4060 MICROFILM SUBFUNCTION

4.20.3.1 Input

The input to this subfunction will be a data file containing the Adage display list of images shown on the Adage CRT. The file will be created on the Adage graphics terminal 330 system.

4.20.3.2 Processing

Upon user command, this subfunction should capture the display list of the images being exhibited on the Adage CRT. The lists should be retained until the user has completed his activity. Then they should be transmitted to the UNIVAC 1110, where they will be output to the SC-4060 to obtain microfilm. If at all possible, the microfilm images should be exact duplicates of the images displayed on the Adage CRT. This subfunction should be able to recreate all Adage displays, including the movie displays.

4.20.3.3 Output

The output from this subfunction will be SC-4060 microfilm of Adage displays.

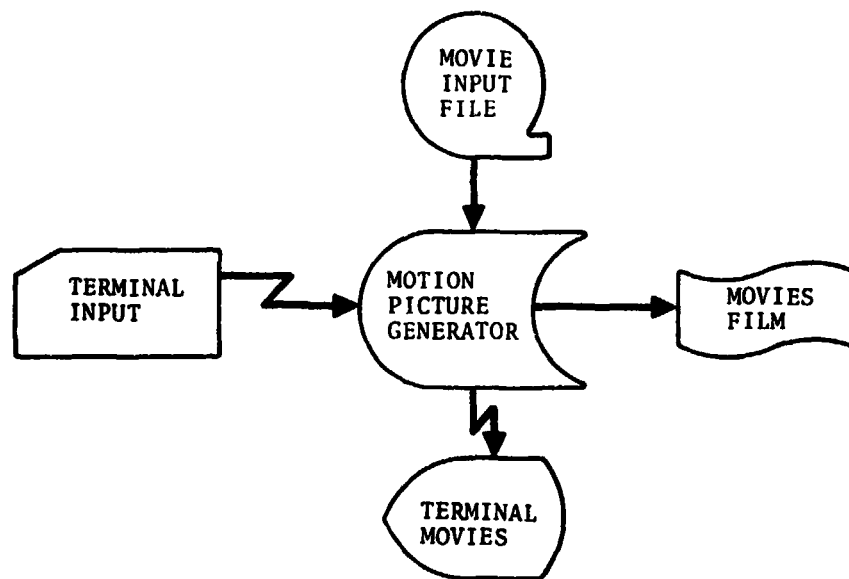

Figure 4.20-1. - Data flow diagram for Motion Picture Generator

4.21 MODEL MATERIAL FILE GENERATOR

4.21.1 PURPOSE

This function will enable a user to select data from the Material Data File, Temperature Data File, and User Model File in order to generate the Model Material File. These data will define temperature-dependent material properties and allowables for each element at a temperature which is input manually or is an average calculated for that element with temperatures from the Temperature Data File. Nontemperature-dependent data can also be included manually or selected from tables and curves constructed from the Material Data File. Figure 4.21-1 is a data flow diagram of the Model Material File Generator.

4.21.2 INPUT

The following files will be used as input to the function:

- User Model File
- Model Temperature File
- Material Data File

Each of these files is described in the appendix.

Input is also required through the remote terminal. Control over the operation of this function will be exercised through the remote terminal.

4.21.3 PROCESSING

The first step in this function will be to read the User Model File and select the data to be displayed. Each element will have a unique number, and the user will have the option of displaying the element list.

Next, the Model Temperature File will be read, and a display will be generated for temperature at each node point. The temperature at each node of an element will then be averaged according to the following formulas. This will be done for all elements, after which the results will be displayed for checking purposes.

If the element is

- CBAR, CONROD, CROD, CTORDRG, or CTUBE

$$T_{avg} = \frac{T_1 + T_2}{2}$$

- CTRBSC, CTRIA1, CTRIA2, CTRIARG, CTRMEM, or CTRPLT

$$T_{avg} = \frac{T_1 + T_2 + T_3}{3}$$

- CDUMi, CQDMEM, CQDPLT, CQUAD1, CQUAD2, CSHEAR, CTRAPRG, or CTWIST

$$T_{avg} = \frac{T_1 + T_2 + T_3 + T_4}{4}$$

- CWEDGE

$$T_{avg} = \frac{T_1 + T_2 + T_3 + T_4 + T_5 + T_6}{6}$$

- CHEXAi

$$T_{avg} = \frac{T_1 + T_2 + T_3 + T_4 + T_5 + T_6 + T_7 + T_8}{8}$$

where:

T_i - temperature at the node point

T_{avg} - element temperature

The user will then specify the material properties and allowables, using data from the Material Data File. Those values which are temperature dependent will be automatically selected from the Material Data File by the program (by referencing the average temperature calculated for the element being processed) unless the user wishes to override and specify another temperature. All data from the Material Data File, whether tabular or curve data, will be display-selectable by the keyboard or by an interactive graphical device, such as a light pen. Additionally, this program will provide for linear interpolation of the curve data.

In the first step of this input, the user will be asked for the material comprising the first element. Next, he will be asked to choose one of the following problem descriptions:

- Isotropic
- Anisotropic
- Orthotropic

Each choice requires a specific group of data for which values will be either selected by the user from tables and curves or manually input. The user will be guided in this selection by menus. The user is not restricted to the data normally grouped under the problem description he has chosen and can input manually any extra data he wishes to enter into the Model Material File. Table 4.21-1 shows the normal groupings of the data. These groupings will determine the data for which the user will specifically be asked, based on his choice of problem descriptions. This input process will be repeated for each element. Finally, displays will enable the user to check and hardcopy his selections. When he is satisfied, the Model Material File will be generated.

4.21.4 OUTPUT

The output from this function will be of two major types, the Model Material File and terminal displays. A description of the Model Material File is contained in the appendix of this document. The detailed format of the file will be developed as part of the functional design specifications. The displays will be developed and presented as described in the previous section and will consist of tabulations and plots.

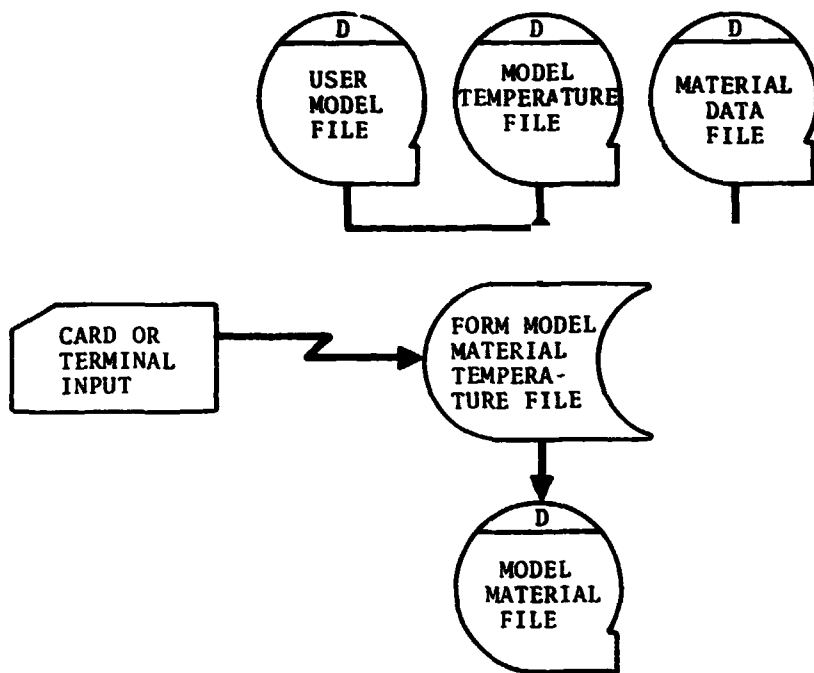

Figure 4.21-1. - Data flow diagram for Model Material File Generator.

ORIGINAL PAGE IS
OF POOR QUALITY

TABLE 4.21-1. - MATERIAL DATA REQUIRED VERSUS
PROBLEM DESCRIPTIONS

Material Data	Isotropic	Anisotropic	Orthotropic	NASTRAN Material Card Name
Material ID number	X	X	X	MID
Young's modulus	X			E
Shear modulus	X			G
Poisson's ratio	X			NU
Mass density	X	X	X	RHO
Thermal expansion coefficient	X			A
Thermal expansion reference temperature	X	X	X	TREF, TO
Structural element damping coefficient	X	X	X	GE
Tension stress limit	X	X		ST
Compression stress limit	X	X		SC
Shear stress limit	X	X		SS
Thermal conductivity	X	X		K
Thermal capacity per unit volume	X	X		CP
Material property matrix		X		G_{ij}
Thermal expansion coefficient vector		X		A_i
Young's moduli in X, Y, and Z			X	EX, EY, EZ
Poisson's ratios (XY, YZ, ZX directions)			X	NUXY, NUYZ, NUZX
Shear moduli for XY, YZ, and ZX			X	GXY, GYZ, GXZ
Thermal expansion coefficients (3)			X	AX, AY, AZ

ORIGINAL PAGE IS
OF POOR QUALITY

4.22 MODEL TEMPERATURE FILE GENERATOR

4.22.1 PURPOSE

This function will be used to generate a data file containing temperature values at each node point of the structural model. Figure 4.22-1 is a data flow diagram of the Model Temperature File Generator function.

4.22.2 INPUT

The major source of data for this function will be the Temperature Data File and the User Model File. The Temperature Data File, which will be created by the Thermal Technology Branch of the Structures and Mechanics Division, will contain a description of the thermal model and the temperature at each node point of the model. The thermal model temperatures must be linearly interpolated to the structural model grid points. The User Model File will contain a complete description (node numbers and their coordinates and element descriptions) of the structural model for which temperature data are required.

A secondary source of data should be the remote terminal. Through this device the user must be allowed to input control information and to manually input temperature values.

4.22.3 PROCESSING

The Temperature Data File will contain data for numerous time frames; the program must provide the capability to display a tabulation of these times. The user will then select the times required for his analysis. The program should allow for the selection of individual times and/or selection of a span of time. After the time frame has been selected, the program will perform a linear interpolation to obtain temperatures at each structural grid point on the User Model File. The user requires the capa-

bility to manually select the thermal node points to be used in the interpolation or to cause the program to select the thermal node points.

4.22.4 OUTPUT

The primary output from this function will be the Model Temperature File. This file will contain the identification and temperature of each structural grid point.

Secondary output will be tabulation and graphical displays from the Model Temperature File, Temperature Data File, and User Model File. The tabulation displays should contain grid point identification; X, Y, and Z coordinates; and temperature. The graphical displays should present the geometry of either the thermal model or the structural model. The program should also have the capability to display the temperature on isotherms on the surface of the model. The user requires the capability to edit the isotherms and to zoom into or out of the displayed image.

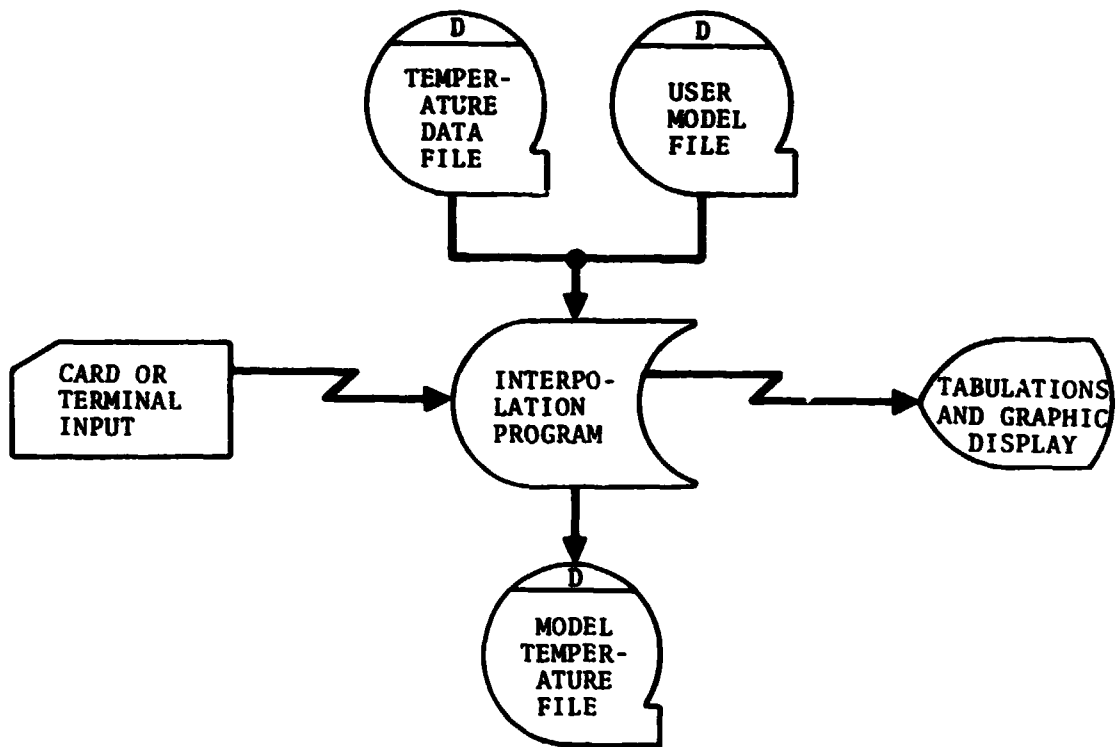

Figure 4.22-1. -- Data flow diagram for Model Temperature File Generator.

4.23 NASTRAN POSTPROCESSING

4.23.1 PURPOSE

This function will analyze the data obtained from a NASTRAN execution. It will use the NASTRAN Output-2 File to tabulate certain stresses, forces, and displacements and to compute several load relationships. This function will also make use of the NASTRAN to FRISBE Modal Tape Conversion Program (NASTOF) to create a User Modal Tape which will supply all dynamic response programs in ISAS with the data required for their analyses. Figure 4.23-1 is the function's data flow diagram.

4.23.2 INPUT

The input will consist of the following files:

- Body Loads Distribution File
- NASTRAN Output-2 File

The NASTRAN Output-2 File will be created in an execution of the NASTRAN program. Input will also consist of data entered by the user from the terminal.

4.23.3 PROCESSING

After execution of the NASTRAN program, the user should have access to the NASTRAN Output-2 File that can be used by this function for postprocessing. The processing function will consist of four subfunctions. These are described as follows:

1. Use of the NASTOF program to convert the NASTRAN Output-2 File to the User Modal Tape
2. Access to the NASTRAN Output-2 File to perform a file search to yield various results (find maximum forces, maximum stresses, plots of displacement, free body diagrams, modal movies, input files, etc.)

3. Computation of internal to external load relationships
4. Calculation of internal loads

Visual displays or menus are to be provided which will lead the user through the processing function. It should be possible for the user to enter this function at the beginning of any of the preceding four subfunctions (a choice made by menu selection). The user should also be able to terminate processing and store all created files at the end of each of the phases; i.e., the user will not be constrained to cycle through the entire process.

4.23.3.1 Execution of NASTOF Program

The first subfunction of processing will be the execution of the NASTOF program. This program will be used to convert the NASTRAN Output-2 File to the User Modal Tape. The User Modal Tape will then supply all dynamic response programs in ISAS with the data required for their analyses.

The first input will be to identify the file name of the NASTRAN Output-2 File. After this name is verified, the terminal user should be requested to input the required data to execute NASTOF. The user should have the choice of entering a file name where these data are stored or entering the data directly from the terminal. This input should consist of title card; coordinate, mass, and modal data conversion factors; and number of modes. After the batch execution of NASTOF, the User Modal Tape will exist on the tape named by the user.

4.23.3.2 File Search on NASTRAN Output-2 File

In the next processing subfunction, a demand program will be used to perform a file search on the NASTRAN Output-2 File to yield results selected from a provided menu. The program will address the NASTRAN Output-2 File to retrieve, sort, calculate, and then display the results. The user will be requested to enter from

the terminal the file name of the NASTRAN Output-2 File to be used as input. The data on the file should be filed by load case number. Any data required to address the program and call up the menu should be requested from the terminal and supplied by the user. After the user has selected an option, there may be additional input for that specific option.

The menu options will be as follows:

1. Load cases can be searched for the maximum displacements of some specified grid points in selected directions. The load cases should be addressable by load case number; the user will be requested to supply the needed data input. The terminal display should be of tabular form containing the load case numbers, grid points, and displacements of that grid in all three directions and the total magnitude of the deflection of that grid.

An example of suitable display is:

TITLE*						
MAXIMUM DISPLACEMENTS						
LOAD CASE	GRID NO.	X (IN.)	Y (IN.)	Z (IN.)	TOTAL DISPLACEMENT (IN.)	
21	213					
	512					
	7012					
	9111					
32	213					
	512					
	7012					
	9111					

The TITLE of the display should be the title on the NASTRAN Output-2 File if available.

2. Load cases can be searched for maximum element forces within "X" percent of the maximum value. For each type of element,

the forces calculated can be unique; i.e., only axial and torsional loads will be computed for a rod, while the shear load and bending moments in two planes will be computed for a bar. Thus, any type of element force comparison must be restricted to similar types.

The user will be requested to supply the needed data input; a display in tabular form should list element numbers and corresponding loads meeting the chosen requirements. The display title should be that of the NASTRAN Output File, and the subtitle should identify the specific option.

An example of a suitable display is:

TITLE	
SUBTITLE	
ROD ELEMENT NUMBER	AXIAL LOAD (LB)
5001	115000.
6115	10351.
7228	10017.

3. Load cases can be searched for specified threshold forces exceeding some input level. As in option 2, any type of force comparison must be restricted to similar types. The element types and force parameters to be searched must be input along with case numbers of interest. A display in tabular form with title and subtitle as in option 2 should list case numbers and threshold forces. The threshold value should also be displayed.
4. Load cases can be searched for forces of defined elements. The terminal user must input the element type, element numbers, forces required, and case numbers. The display should be the same as shown in option 2 with only the subtitle change.

Options 5, 6, and 7 correspond with options 2, 3, and 4 except the processing will be on element stresses instead of element forces.

5. Load cases will be searched for maximum element stresses and all stresses within "X" percent of the maximum value.
6. Load cases will be searched for specified threshold stresses exceeding some input level.
7. Load cases will be searched for stresses of defined elements.
8. Load cases can be chosen and displacements plotted. When this option is selected, all plotting specification data input by the user or taken from the NASTRAN Output-2 File should correspond with the NASTRAN structural plotting controls but be limited to (1) set definition, (2) axes definition, (3) view angle definition, (4) maximum deformation, (5) FIND card, and (6) PLOT card and the options that will be available on each of these cards. The displays should be the selected structural plots, appropriately labeled with title and case number from the NASTRAN Output-2 File.
9. Load cases can be searched and free body diagrams plotted. This option is currently available only when the section to be cut is adjoined by the following elements: (1) rods, (2) bars, (3) shear panels, and (4) triangular membranes. The reason for this limitation is that element loads will only be computed in level 15.5 of NASTRAN for rods, bars, and shear panels. Although the grid loads for triangular membranes will not be computed, it may sometimes be necessary to include them in finite element modeling to simulate irregular geometries; therefore, it will be necessary to include an approximation for the triangular membrane grid forces in the free body calculations. The engineer-user will have the responsibility of being certain that when this option is selected, a proper cutting plane is defined such that the preceding limitation is observed.

An example of using this option follows.

A section of a finite model is to be analyzed in more detail than is included in the structural element modeling. A three-dimensional space should be defined to include the section desired. The program should search the element data and find all elements lying fully in this space. Some elements will connect to grids in the space. These are to be removed, and forces are to be calculated to apply to the grids to which they are connected. The following substitutions will be made.

- Rod – The axial load along the rod axis and the torque along the rod axis will be substituted.
- Bar – The axial load along the bar axis, the torque along the bar axis, and the moments and the shear in two planes at the appropriate end will be substituted.
- Shear panel – The appropriate corner forces to compute total loads on grids in selected space will be substituted.
- Triangular membranes – The corner forces will not be available, so approximate values must be computed. Stress along the appropriate direction will be multiplied by length and thickness to obtain total force. This total force will be divided in one-third and two-third proportions for corner forces.

There should be at least two methods of defining the three-dimensional space to be used in analyzing a section. The first will be by entering the parameters X_1 , X_2 , Y_1 , Y_2 , Z_1 , and Z_2 ; the second by defining eight points in space by coordinates X_i and Y_i .

The capability to plot the structural elements that occupy the selected space should exist, and force vectors with magnitudes should be shown. The plots should be labeled sufficiently.

10. SC-4020 language data tapes will be generated to be processed into modal movies on 16-millimeter movie film. The requirements of this capability are detailed in another section of this document.
11. Modal movies will be generated to be viewed at the Adage user's console. The requirements of this capability are detailed in another section of this document.
12. Application program input files can be generated. In this option, the NASTRAN Sorted Data File should be created as an application program input file. This option should provide the user with a menu of possible application program input files that can be generated; the file should be generated according to the format of the file selected by the user (described in the appendix). A file name should be supplied by the user for storing the created file. Currently, only one file will exist in this menu: the program input file to Fatigue Assessment processing.
13. Grid displacements to a finer model can be generated. This option should be utilized to take the grid point displacements for a specified set of nodes and create a set of single point constraint (SPC) card images to be input to a subsequent, though more detailed analysis. The user should input the SPC identification number along with the set of grid points desired. An option should exist to alter the grid point numbers to correspond to the new model. The data needed for processing should be accessed from the NASTRAN Output-2 File by referencing case numbers. A file name should be supplied by the user for storing the created file.
14. Demand program input files can be generated. In this option, the NASTRAN Sorted Data File should be created as a demand program input file. This option should provide the user with a menu of possible demand program input files that can be generated, and based on the user's choice, the file should

be generated according to the file format (described in the appendix). A file name should be supplied by the user for storing the created file. Currently, only one file (NASTRAN Sorted Data File) will exist in this menu. This file will be used in the next demand program for computing internal-to-external load relationships. The NASTRAN Sorted Data File will be created by addressing the NASTRAN Output-2 File by case number and retrieving the element geometry and stress data. Element stresses for at least six cases are required for processing. These cases must match identically the body load cases of the Body Loads File, which will be used in the same program. The user will be able to verify that the cases are compatible.

15. NASTRAN contour plots will be generated and viewed at the Adage user's console. The option will allow the design engineer to immediately identify the critical design areas and aid in the evaluation of the large amount of data generated in a typical NASTRAN analysis. The user will be able to select NASTRAN output data to be plotted, such as stresses, displacements, and mode shapes for planform surfaces of the structure. The user will be required to define the surface to be plotted by entering grid point sets and to select from a menu the plot or plots to be made. Also, the user will be required to select the loading condition for the plots.

This plotting option will cause the NASTRAN input data to be searched to determine the grid numbers and elements to be included in the surface and the NASTRAN output data to be searched for the deflections, stresses, and mode shapes that correspond to the grid numbers and elements.

After the selected options have been executed, the user should be able to display the NASTRAN Sorted Data File on the terminal. The type of data on the file will be dependent on the options

selected. The file could contain input data for other demand or application programs or the requested terminal displays generated by the subfunctions.

After viewing the NASTRAN Sorted Data File, the user should be able to print out in page size (8 × 10-1/2 inches) tabular form any alphanumeric-type displays generated. After viewing a terminal display of the plots created by the demand program, the user should be able to generate SC-4060 copies of any of these plots.

Processing can be terminated at this point or continue to the next subfunction.

4.23.3.3 Internal-to-External Load Relationship Computation

The next subfunction in processing is the execution of the demand program to compute internal-to-external load relationships. When beginning this phase, the terminal user should be requested to give the names of the input files – NASTRAN Sorted Data File and Body Loads File. The NASTRAN Sorted Data File may be the file just created or it may have been created during a previous post-processing step.

The Body Loads File will contain the shear forces and bending moments about three axes as functions of defined body stations. The data will be arranged by load station (defined by Cartesian coordinates), followed by a component load breakdown of the shears and moments.

As many as six load cases can be required, and since all the cases of interest may not be on one file, the user should be able to enter several file names for this file. The user should also supply the file name of the output file (Load Output File).

After the file names have been verified, the terminal user should be requested to supply the input data. The shears and bending moments to be used in the run must be identified if all three shears and all three moments are not to be considered. The control points of interest (in terms of Cartesian coordinates) must be input for use in retrieving the appropriate data sets from the Body Loads File, and each element set that is associated with each control point must be identified. This should be done by assigning element types and numbers to each control point.

The demand program should then read the NASTRAN Sorted Data File and Body Loads File to retrieve the data to match the set of load points of interest. Components should be summed to obtain the total shears and moments at a station. The program should calculate the relationships between the control point loads and the set of element stresses as defined by the input (i.e., for each control point, there will exist some set of elements whose stresses can be calculated by assuming the loading distribution will change only slightly for the input cases and, thus, will allow a linear solution for the following coefficients).

[L] - load matrix at control point; i.e., $V_x, V_y, V_z, M_x, M_y, M_z$

[A] - coefficient matrix desired

[σ] - element stress matrix

The diagonal matrix [L] can have maximum dimensions of 6×6 . However, if all the components of load at the control points of interest are not to be considered, the matrix can be reduced to some value N , such that $1 \leq N \leq 6$. The rectangular matrix [A] will have dimensions $N \times M$, with N defined as $1 \leq N \leq 6$ and M being dependent on the type of element (i.e., for a rod, M will have a value of 2 since two element stresses, axial and torsional, will be computed by NASTRAN for rods). Each element

type will have some specific set of stresses computed to define the value of M . The rectangular matrix $[\sigma]$ will have dimensions $N \times M$ as above. The computation of the $[A]$ matrix will require the inverse of the $[L]$ matrix as indicated below.

$$\begin{array}{ccccc} [L] & \cdot & [A] & = & [\sigma] \\ N \times N & & N \times M & & N \times M \end{array}$$

or

$$[A] = [L]^{-1} \cdot [\sigma]$$

Since there will be as many $[\sigma]$ matrices as elements associated with a given control point and multiple control points will exist, a number of $[A]$ matrices must be calculated (the maximum will be the total number of elements in the model). There will be, however, only as many $[L]$ matrices as control points selected; consequently, these matrices can be used repeatedly to compute the $[A]$ matrices.

Execution of this demand process will yield the Load Output File. This file should contain the control points, the associated element sets, and the coefficient matrices relating the element stresses to the control point loads.

Processing can be terminated at this point or continue to the next subfunction.

4.23.3.4 Internal Loads Computation

The execution of the demand program to compute internal loads will be the post processing subfunction. The user should identify the name of the input file as the Load Output File just created or created during a previous postprocessing step. The input should cause selection of the control points of interest

with all associated elements in that set or some specified number of elements in that set. An alternate method should allow the user to input element types and numbers and have the program select the appropriate coefficient matrices required from the Load Output File. Then the values of shears and bending moments at the control points of interest must be input for each case.

After the control points and their selected elements have been input, the demand program will take the loads at those control points and compute stresses for the elements of that set. These stresses will be calculated as follows:

$$[\sigma] = [L] \cdot [A]$$

where the matrices are those described in the previous phase of this section. Once stresses are computed for all control points and all cases, the resulting stress data will be stored in a temporary output file.

The temporary output file will not be saved after termination of the run. It should contain the case numbers, control points and applied loads, and element identifications and stresses. All this information should be available for terminal displays. Displays should be in the form of tabulations of the input data and resulting computed stresses per case number and element.

4.23.4 OUTPUT

The following files will be available as output:

- User Modal Tape
- NASTRAN Sorted Data File
- Load Output File

These files are defined in the appendix. Tabular printouts of all displays produced in the analysis of the NASTRAN Output-2 File will also be available.

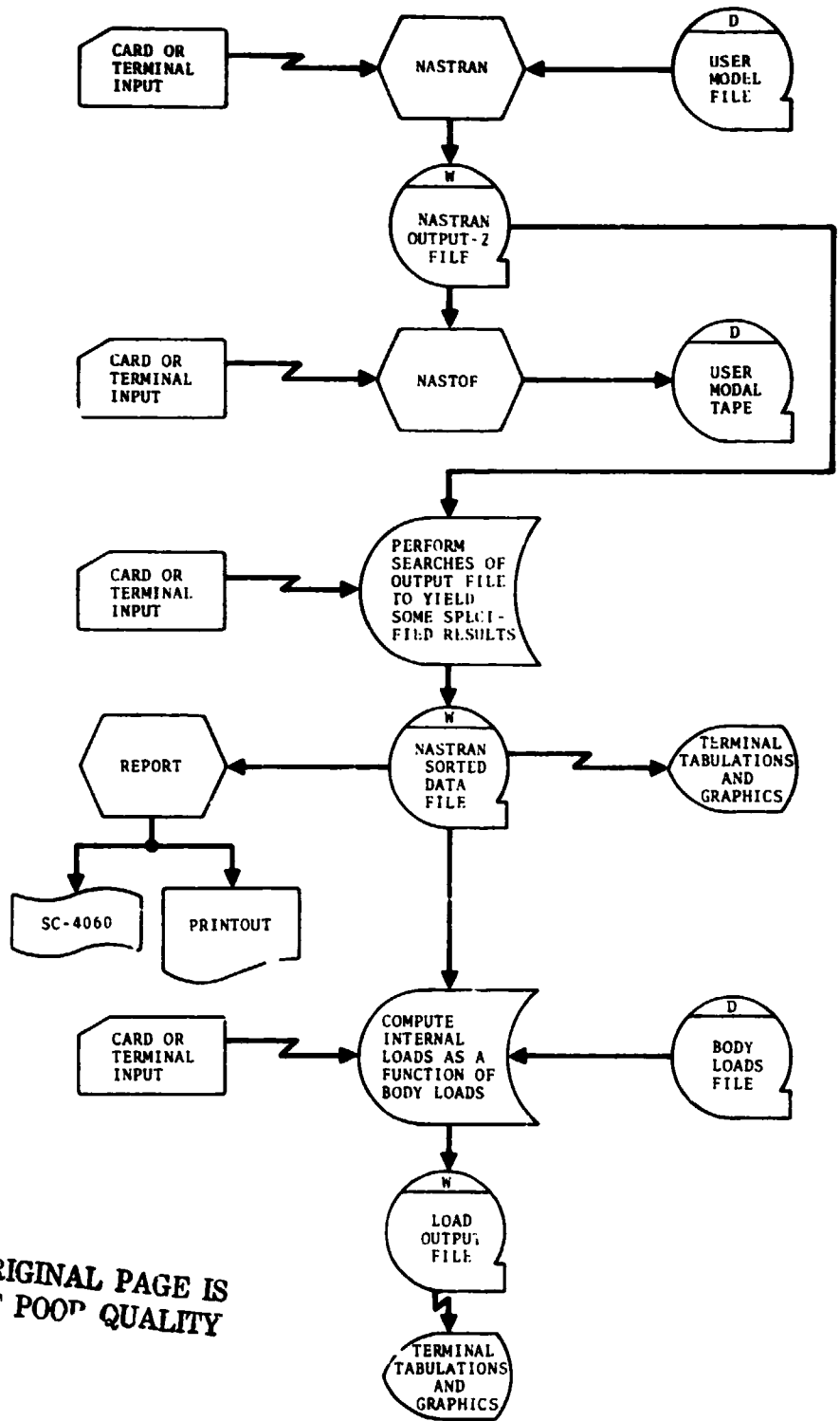

ORIGINAL PAGE IS
OF POOR QUALITY

Figure 4.23-1. - Data flow diagram for NASTRAN Postprocessing.

4.24 PANEL FLUTTER

4.24.1 PURPOSE

This function will consist of two subfunctions. The first subfunction will provide the capability to prepare an input data file for the batch Panel Flutter Program. After creating this input file, the subfunction will output tabulations of the data on the file to ensure it is made correctly. The second subfunction will provide the capability of tabulating data from the Panel Flutter Output File. Figure 4.24-1 is a data flow diagram for Panel Flutter.

4.24.2 INPUT

Input to this function will be obtained from data input at the terminal and from the data files listed below.

- Basic Data File
- Standard Atmosphere File
- User Model File
- Stiffness, Mass, and Modes File
- Panel Flutter Output File

Detailed descriptions of these files can be found in the appendix. The user will have the capability to modify any of the data obtained from the above files by the use of commands input at the remote terminal.

Data input at the terminal will consist of control information, grid point identification, grid point coordinates, element definitions, and nodal constraints. This input will be discussed in detail in the following section.

5 PROCESSING

This function will consist of two subfunctions. The first subfunction will prepare the Panel Flutter Input File to be used

by the batch Panel Flutter Program. The second subfunction will provide the capability for the user to examine the data contained on the Panel Flutter Output File.

4.24.3.1 Panel Flutter Input File Preparation

The Panel Flutter Input File will be prepared primarily from terminal input, with some data being retrieved from the Basic Data File and the Standard Atmosphere File. At this time, the NASTRAN Program does not have a bending plate element compatible with the Panel Flutter Program formulation. Therefore, the Stiffness, Mass, and Modes File (which is output by NASTRAN) and the User Model File are not required at this time. When NASTRAN is updated to contain the desired element formulation, these two files will then be required.

Information from the Basic Data File and the Standard Atmosphere File will be used in determining the Mach number, dynamic pressure, and free-stream velocity. If a Basic Data File is available, the user will input the trajectory ID number and the flight time at the terminal. Using these two parameters, the Mach number, dynamic pressure, and free-stream velocity will be retrieved from the Basic Data File.

If a Basic Data File is not available, the Mach number (M) and altitude will be input at the terminal. Using this altitude, the air density (P_a) and speed of sound (C) will be retrieved from the Standard Atmosphere File. The free-stream velocity (V) will be computed as follows:

$$V = MC$$

The dynamic pressure (q) will be computed as follows:

$$q = \frac{1}{2} P_a V^2$$

After determining the Mach number, dynamic pressure, and free-stream velocity, the following data will be input at the terminal:

- Plate thickness
- Poisson's ratio
- Young's modulus
- Mass density of plate
- Panel Flutter Program control options which are described in the computer program documentation for Panel Flutter Program (Program G131).
- 144-character title
- Grid point ID numbers
- Grid point coordinates
- Grid point external ID numbers
- Definition of elements
- Nodal constraints

After these data are input, they will be tabulated for user verification and then formatted and output on the Panel Flutter Input File. The program will then recycle. The user can create as many files on the Panel Flutter Input File as he wishes.

4.24.3.2 Panel Flutter Output File Display

When this subfunction is selected, the user must input the name of the file to be displayed. Each Panel Flutter Output File can contain several files of data. Each file will be in the same format so the program will have one display format for all files. This display format should tabulate the following data from each file:

- 144-character title information
- Number of grid points

- Smallest grid point ID
- Largest grid point ID
- Number of elements
- Grid point ID and grid point coordinates for each grid point
- Element nodes for each element
- First natural frequency of input panel
- Second natural frequency of input panel
- Calculated flutter frequency
- Calculated dynamic pressure at flutter frequency

4.24.4 OUTPUT

Output from this function will consist of the Panel Flutter Input File, the Panel Flutter Output File, and tabulations of the data contained on the Panel Flutter Input File and the Panel Flutter Output File.

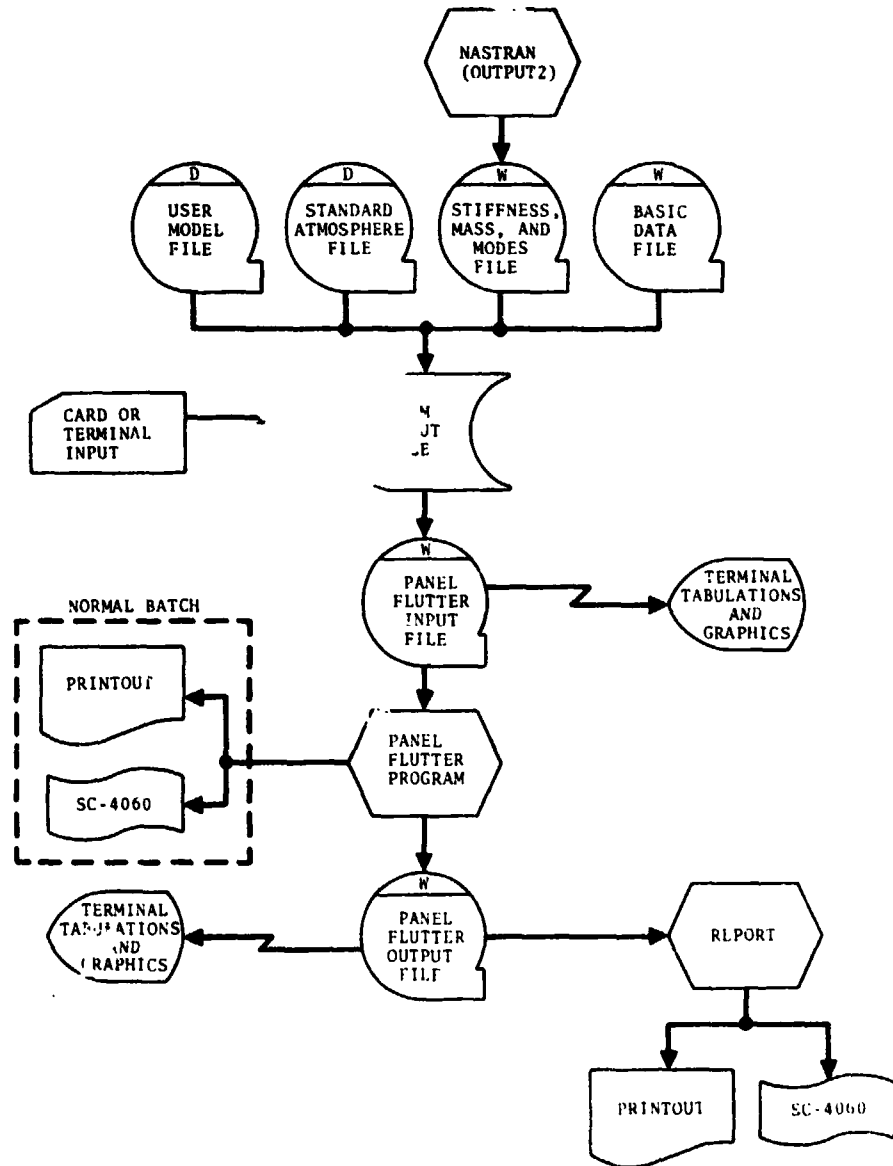

ORIGINAL PAGE IS
OF POOR QUALITY

Figure 4.24-1. - Data flow diagram for Panel Flutter.

4.25 POGO STABILITY

4.25.1 PURPOSE

This function will provide the demand capability to prepare data files for input to the Propulsion System Model Characteristics Program (PSMC) and the Stability Preprocessor Program (SPP). Also included will be the ability to generate graphical and tabular displays of data contained on the NASA POGO Stability Program (NAPSAP) Output Data File and the Linear Systems Dynamics Program Output File. Figure 4.25-1 is the data flow diagram for POGO Stability.

4.25.2 INPUT

The input to this function will consist of the following:

- The Feedline Modal Data File, (in User Modal File format), which will be output by the NASTRAN-to-FRISBE Modal Tape Conversion Program (NASTOF), is required when preparing the Selected Feedline Data File.
- The User Modal File is required when preparing the Selected Modal Data File for the Stability Preprocessor Program.
- The NAPSAP Output Data File is required for the generation of tabular and graphical displays of its data.
- The Linear Systems Dynamics Program Output File is required for the generation of tabular and graphical display of the data contained in that file.

The interactive input capability of the remote terminal will be used in conjunction with the preceding input methods.

4.25.3 PROCESSING

Processing requirements of this function can be separated into two areas:

- Selection of modal data and creation of an input file for the batch analysis programs

- Generation of tabular and graphical displays from input/output files used by the demand function

In the selection of modal data, the user will be required to identify the User Model File to be as input. After the file has been assigned, the program will identify the data sets contained in the file and will request the user to select the data set which is required. The program will then display the title block from the selected data set for validation.

At this point, the program will allow the user to display the modal data, select the degrees of freedom, and select the format. The user must be allowed to select the modes or degrees of freedom either individually, in groups, or by indicating all.

After the selection has been made, the program will provide a display of only the selected data. The modal data will be displayed using two tabular formats. The first tabular display will contain data which describe each node. Figure 4.25-2 is an example of this type of display. The second display (fig. 4.25-3) will contain the mode versus frequency table. Each table will be displayed a page at a time, and the user will control the advancement. The user will have the capability to terminate the display at any time and select another program option.

Another method for selecting modal data will be through the use of modal gain. In this case, the user will select the modes and degrees of freedom either individually, in groups, or by indicating all, and the input file will be used to obtain PHI for each selected mode. One of the following expressions will be evaluated for each selected mode and degree of freedom.

$$\text{Modal gain} = \frac{\text{PHI}(I)**2}{\text{GMASS}} \quad (1)$$

$$\text{Modal gain} = \text{PHI}(I) * \text{PHI}(J) / \text{GMASS} \quad (2)$$

where

PHI(I) – modal displacement of *I*th selected degree of freedom

PHI(J) – modal displacement of selected reference degree of freedom

GMASS – generalized mass

These computed values will be ordered in descending magnitude and displayed for each degree of freedom. (If (1) is used, PHI(J) = PHI(I).) Figure 4.25-4 is an example of this display.

The u. will also have the capability of ordering the mode numbers by the number of occurrences and displaying them as shown in figure 4.25-5. Additionally, the selected modal data versus selected mode numbers are to be displayed as shown in figure 4.25-6.

4.25.4 OUTPUT

Most of the output from this function is described in previous sections. Additional output will consist of tabulations and graphics. Figure 4.25-7 is an example of a frequency versus damping display. The data for this display will be obtained from files created by this function. The graphical displays will consist of plots of magnitude versus phase angle of the eigenvectors with degrees of freedom numbers. Figure 4.25-8 is an example of this display.

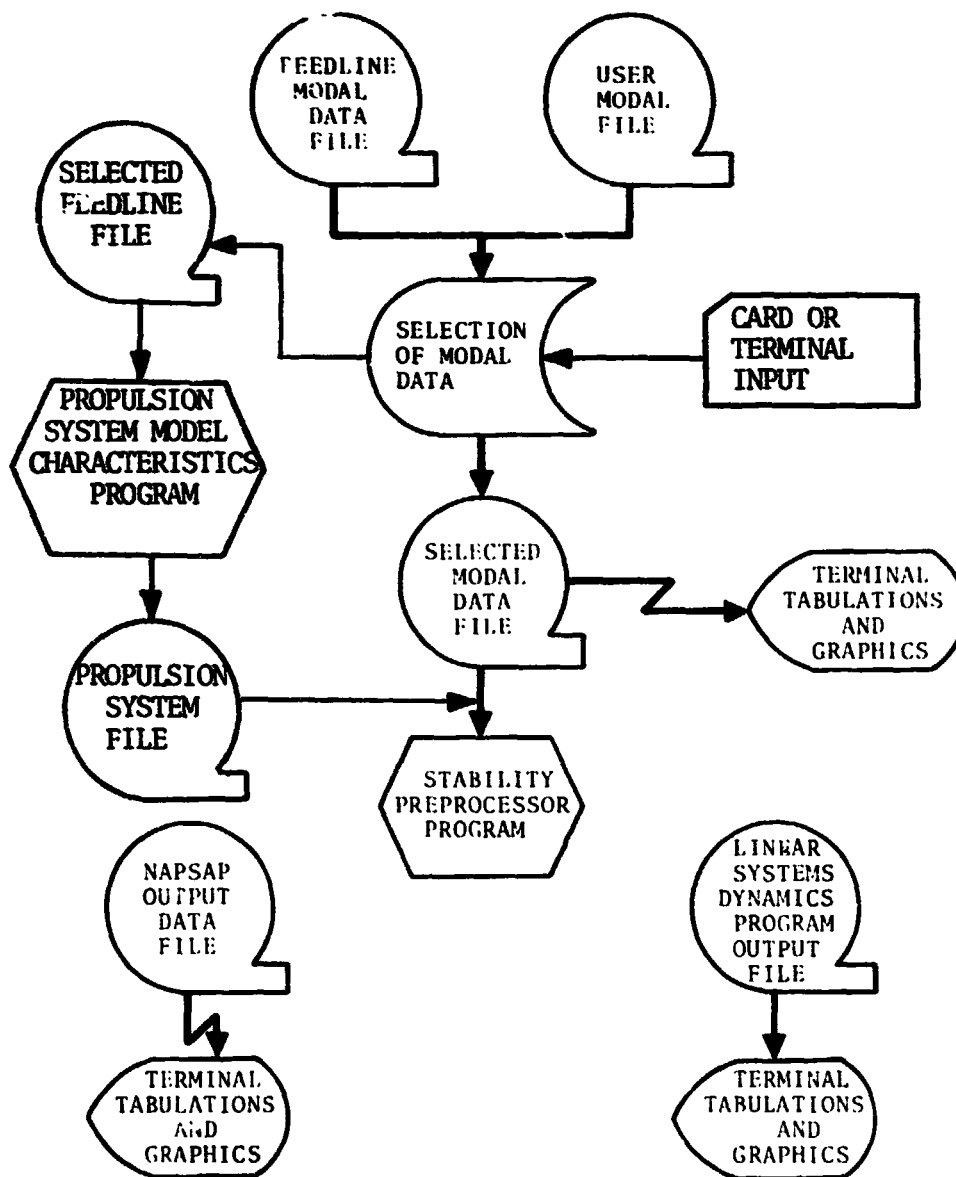

Figure 4.25-1. - Data flow diagram for POGO Stability.

ORIGINAL PAGE IS
OF POOR QUALITY

C.4

NODE ID	X	Y	Z	NODE DESCRIPTION/NAME	DEGREES OF FREEDOM
1	270.00	0.00	346.00	FUSELAGE ORB STA X=270.0	13
2	327.84	21.00	329.34	FWD LANDING GEAR - DRAG	13
3	346.00	0.00	371.00	ORBITER RCS TANKS C.G.	13
4	375.50	21.00	298.00	FWD LANDING GEAR - MAIN	13
5	378.09	0.00	353.20	FUSELAGE ORB STA X=378.0	13

Figure 4.25-2. - Node identification display.

MODE NUMBER	FREQUENCY		MODE NUMBER	FREQUENCY	
	RADS/SEC	HZ		RADS/SEC	HZ
1	14.994	2.3864	2	21.878	3.4821
3	27.328	4.3493	4	32.163	5.1188
7	42.356	6.7412	8	46.050	7.3291
9	48.606	7.7359	10	51.769	8.2292

Figure 4.25-3. - Mode versus frequency display.

FIRST 100 ORDERED MODAL GAINS, PHI(I)= 621, PHI(J)= 631

MODE	GAIN	MODE	GAIN	MODE	GAIN
53	.331199-01	27	.671460-02	49	.638531-02
52	.556015-02	20	.500651-02	24	.374247-02
2	.164820-02	30	.141136-02	56	.136553-02
36	.918382-03	21	.753562-03	58	.721258-03
60	.689881-03	4	.657137-03	51	.649503-03
43	.567410-03	31	.541321-03	8	.387945-03

Figure 4.25-4. - Display of modal gain for selected degree of freedom.

THE ORDERED MODE SAVE ARRAY ACCORDING TO NUMBER OF OCCURANCES IS

MODE	OCCURRED	MODE	OCCURRED	MODE	OCCURRED
8	3	6	3	2	3
9	3	5	3	1	2
3	2	10	1	4	1

Figure 4.25-5. - Display of ordered mode save array according to number of occurrences.

SELECTED MODAL DATA
FOR MODE NUMBER 1

FREQ IN RADS/SEC		FREQ IN HZ	
12.387		1.971	
DOF	PHI	DOF	PHI
631	-.17590733+01	623	.29012012+01
641	-.14110537+01	643	.31095724+01

Figure 4.25-6. - Display of selected modal data.

103074,LOFF,NO ACCUM,GLP=5.0,2 HZ MODE RUN 15

FREQUENCY (RADS/SEC)	FREQUENCY (HZ)	DAMPING (PERCENT CRITICAL)
14.794	2.3545	.80358
17.838	2.8390	23.43909
54.558	8.6832	6.77594
69.625	11.0812	.98263
93.213	14.8353	3.10567
121.364	19.3157	18.59779

Figure 4.25-7. - Frequency versus damping display.

L75 FREQ= 17.773 HZ, DAMP= 1.0239

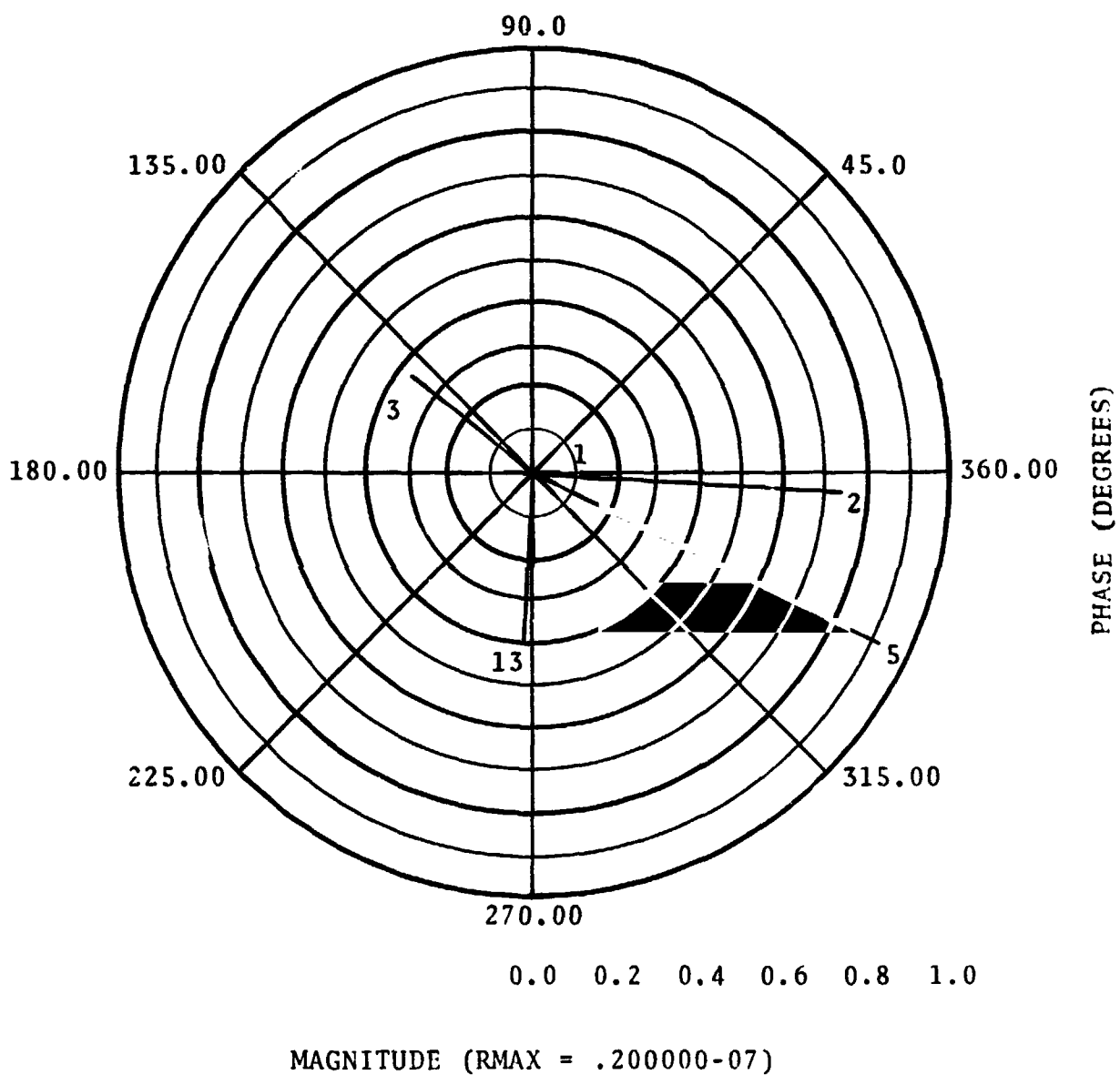

Figure 4.25-8. - Eigenvector display.

4.26 PROPERTIES AND ALLOWABLES

4.26.1 PURPOSE

This function will provide section properties and allowables data for the stress analysis of stiffened panels and built-up beams. A file of section properties will be created and will be available for use by other ISAS functions and batch programs. Figure 4.26-1 is a data flow diagram of the Properties and Allowables function.

4.26.2 INPUT

The input data required by this function can be obtained from the Basic Structural Dimensions File, Model Material File, and manual input. The Basic Structural Dimensions File will contain the section dimensions and element properties of the model generated by the user. The format and description of the file is contained in the appendix. The Model Material File will contain model material properties that will be generated by the user from the User Model File, Model Temperature File, and the Material Data File.

The input information required for this function will be in terms of the coordinates of the stations within the modeled regions versus the material properties. In general, the only information needed will be the material compressive modulus, material tensile ultimate stress, Poisson's ratio, material compressive yield stress, and material shear stress allowable at the design temperature. The manual input capability must allow for the input or modification of any of these data.

4.26.3 PROCESSING

For each station, the program will obtain the station coordinates (X, Y, and Z) and the geometry parameters (b, t, R, ϕ) from the Basic Structural Dimensions File. The Model Material File will then be used as input to retrieve the material compressive

modulus, material tensile ultimate stress, Poisson's ratio (μ), material compressive yield stress, and material shear stress for each station. The data from the two files will be correlated using the station coordinates.

In addition to the information above, there is a requirement for the material secant and tangent moduli to calculate the plasticity correction factors for each station. Most likely these data will not be available from the Model Material File for the design temperature being considered. Therefore, an option will allow the user to input the required parameters if the plasticity correction factor is to be considered in any buckling equations. The data required for input will be the Ramberg-Osgood parameters which can be used to represent the material compressive stress-strain curve in mathematical terms. The user will have the option of inputting one of two sets of data. The first set will be the parameters for the curve shape factor n (one value) and the curve secant yield stress $F_{0.7}$. The second set will be the information from the material compressive stress-strain curve that can be used to calculate the Ramberg-Osgood parameters. This data will be the 0.20 and the 0.05-percent offset stresses $F_{0.20}$ and $F_{0.05}$ from the curve. If the second set of data is given, the function will be required to calculate the parameters from the following relations:

$$n = \frac{\ln(4)}{\ln\left(\frac{F_{0.20}}{F_{0.05}}\right)}$$

$$F_{0.7} = F_{0.2} \left(214.3 \frac{F_{0.2}}{E}\right)^{\frac{1}{(n-1)}}$$

where E is compressive modulus.

All this data must be saved by station number and output into the Interim Properties and Allowables File. The program must provide the capability to tabulate all of the data contained in the Interim Properties and Allowables File. An example of the tabulation format is shown in figure 4.26-2. The user must have the capability to edit all data displayed in the tabulations and, thereby, update the file.

After the Interim Properties and Allowables File has been completed and accepted, the user should be asked if he wants to compute section allowables. If he specifies no, this should cause the program to transfer and prepare section properties (see section 4.26.3.4). A yes choice should cause the program to proceed and calculate local buckling allowables. Regardless of the path selected, the data generated plus the data from the Interim Properties and Allowables File will be output onto the Section Properties and Allowables File.

4.26.3.1 Local Buckling

This part of the program will calculate the section's local buckling allowable for each station. Due to the different data types, user input will direct the program to the proper local buckling calculation. In the event a free form configuration is used, the program will display the data for each station before that station is processed, and the user will identify each parameter. For all configurations or stiffened panels (configuration ID's 1 to 15), the program will use the procedure described in section 4.26.3.1.1 to determine local buckling allowables. The procedure described in section 4.26.3.1.2 will be used for beam configurations. In each of these procedures, user's choice will exist for the calculation of the local buckling equation using the plasticity correction factor. The user may want to ignore this factor for the calculations; for this case, the value of n should be a constant 1.0.

4.26.3.1.1 Stiffened Panels

The following basic buckling expression will be used for stiffened panels with configuration ID's 1 through 14.

$$FC = \frac{\eta K_c \pi^2 E}{12(1 - \mu^2)} \left(\frac{t}{b}\right)^2$$

where

FC - local buckling stress

η - plasticity correction factor

μ - Poisson's ratio

E - material compressive modulus (Young's modulus)

b, t - geometry parameters from Interim Properties and Allowables File

K_c - compressive buckling coefficient (see fig. 4.26-3)

For the semicircle corrugation semisandwich configuration (configuration ID 15), the following equation will be used to calculate local buckling.

$$FC = \frac{K_c E \bar{\eta}}{\sqrt{3}(1 - \mu^2)} \left(\frac{t}{R}\right)$$

where

$\bar{\eta}$ - plasticity correction factor (circle)

R - radius from Interim Properties and Allowables File

K_c - compressive buckling coefficient (see fig. 4.26-6, page 4-294)

Each pair of the section parameters b and t will represent an element of a station. The program will calculate a value for local buckling for each element. Table 4.26-1 shows the required calculations for each configuration and the identification of reference curves. For each calculation, the user will supply either the element aspect ratio a/b or the panel or element length a . If the panel or element length a is input, the program will calculate the element aspect ratio a/b using the value of b from the Interim Properties and Allowables File.

Both buckling equations will contain a plasticity correcting factor η or $\bar{\eta}$. For the first calculation of the element buckling stress, the program will assume that the values of η and $\bar{\eta}$ are 1.0. If the results of the calculation are less than the material compressive yield stress, then the assumption is correct. However, if the results are higher than the material compressive yield stress, an iteration procedure must be performed to determine the correct value of η and $\bar{\eta}$. This procedure is given below.

1. The upper stress is assumed to be 20 percent higher than the material compressive yield stress. This stress is used as the assumed stress for the following calculations.
2. The modulus ratios will be calculated from the following relationship.

$$\frac{E_s}{E} = \frac{1}{1 + (3/7) \left(\frac{F}{F_{0.7}} \right)^{n-1}}$$

$$\frac{E_t}{E_s} = \frac{1 + (3/7) \left(\frac{F}{F_{0.7}} \right)^{n-1}}{1 + (3/7) (n) \left(\frac{F}{F_{0.7}} \right)^{n-1}}$$

where

E_s - material secant modulus

E - material compressive modulus

E_t - material tangent modulus

F - assumed stress

n - curve shape factor (from previous input or calculation)

$F_{0.7}$ - curve secant stress

3. The nonlinear Poisson's ratio will be calculated from the relation:

$$\mu_p = 0.5 - \left(\frac{E_s}{E} \right) (0.5 - \mu)$$

where

μ - elastic Poisson's ratio

4. The plasticity reduction factor will be calculated from one of the following relations. For rectangular elements:

$$\eta = \left[\frac{\left(\frac{E_s}{E} \right) \left(\frac{1 - \mu^2}{1 - \mu_p^2} \right)}{\left(\frac{E_s}{E} \right) \left(\frac{1 - \mu^2}{1 - \mu_p^2} \right)} \right] \left[0.5 + 0.25 \left(1 + \frac{3E_t}{E_s} \right)^{1/2} \right]$$

For circular elements:

$$\bar{\eta} = \frac{1}{\left\{ \left[1 + (3/7) \left(\frac{F}{F_{0.7}} \right)^{n-1} \right] \left[1 + (3/7)n \left(\frac{F}{F_{0.7}} \right)^{n-1} \right] \right\}^{1/2}}$$

5. This value will be substituted for η or $\bar{\eta}$ in the proper buckling equation, and the buckling stress will be

recalculated. The calculated stress will be compared with the assumed stress.

- a. If the results are within 0.1 percent or less of the assumed value, then the assumed stress will become the element local buckling stress. This value for the element will be stored for later use.
 - b. If the calculated stress is higher than the assumed stress, then the assumed stress will become the lower bound stress, and the stress calculated for $\eta = 1.0$ will become the upper bound stress. The actual buckling stress will lie between these two bounds.
 - c. If the calculated stress is lower than the assumed stress, then the assumed stress will become the upper stress, and the material compressive yield stress will become the lower bound stress.
6. Once the upper and lower bound stresses are established, the next step will be to average the difference between the two and add this to the lower bound stress. This stress will then become the assumed stress for the next iteration.
 7. The calculations of steps 2 through 5 will be performed, and the following tests will be performed.
 - a. If the difference between the assumed and calculated stress is within 0.1 percent or less of the assumed value, then the assumed value will be the local buckling stress for the element.
 - b. If the calculated stress is lower than the assumed stress, then the assumed stress will become the new lower bound stress.
 8. Steps 6 and 7 will be repeated until the convergence test of step 7a is satisfied.

The program will perform each of the calculations shown in the columns of table 4.26-1 for the selected panel configuration and save these data for the stress calculations to be performed later. When the last calculation has been completed, the program will compare the stiffener subelement stresses and select the lowest absolute value as the local buckling stress for the station. The selected value will be saved and output on the Section Properties and Allowables File. The stiffener element stresses for each element of the station will also be saved for later use in the crippling calculations.

4.26.3.1.2 Beam Sections

The local buckling expression for beam sections will be:

$$FC_i = \frac{\eta K_c \pi^2 E}{12(1 - \mu^2)} \left(\frac{t_i}{b_i} \right)^2$$

where

- FC_i - element local buckling stress
- K_c - compressive buckling coefficient
- η - plasticity correction factor
- E - material compressive modulus
- t_i, b_i - geometry parameters
- μ - Poisson's ratio

The program will retrieve the data contained on the Interim Properties and Allowables File and start the calculations with region 1, station 1. The program will use the element geometry terms, starting with b_1 and t_1 , and calculate the buckling stress FC_i for each subelement. The user will be required to

furnish the buckling coefficients K_c for each subelement and the edge conditions. The users choice for these conditions may be made from table 4.26-2 or figure 4.26-3. These calculations need be performed for only one beam axis.

The plasticity correction factor η will have the value of 1.0 for the first calculation of each subelement. If the resulting stress calculation for the subelement is less than the material compressive yield stress, then the assumption that η is equal to 1.0 will be correct, and the local buckling stress for the subelement will be stored for later use. If the resulting stress calculation is greater than the material compressive yield stress, then an iterative procedure will be required to find the correct value of η . This procedure will be the same as for the flat rectangular elements (configurations 1 through 14) of the stiffened panel concept.

After the last subelement calculation has been completed, the program will store these local buckling values for later calculations and compare them with each other. The lowest absolute value will be the local buckling stress for the section. This value will be stored in the Section Properties and Allowables File.

4.26.3.2 Crippling Allowable

This subfunction will allow the user to cause the program to calculate the crippling allowables for each station. The program will be interactive and allow the user to control the flow of calculations and to select what data will be input manually.

4.26.3.2.1 Stiffened Panel

The local buckling stress FC_1 for each element of the stiffened panel will be calculated as shown in the previous section. Each configuration of the stiffened panel will require a different

equation to calculate crippling stress, and for convenience, these equations are shown in table 4.26-3. These equations should be programmed so that the user can modify any value. The calculated values will be saved and output on the Section Properties and Allowables File.

4.26.3.2.2 Beam Sections

It is imperative that the correct local buckling stress be coupled with the subelement geometry parameters b and t . Therefore, the user must have the ability to monitor the program as well as make any corrections that might be required. The equation to be used while calculating crippling allowables for beams is:

$$FCC = \frac{\sum_{i=1}^N FC_i b_i t_i}{\sum_{i=1}^N b_i t_i}$$

where

N — the number of subelements at a station

FC_i — element local buckling stress

b_i, t_i -- geometry parameters

FCC — crippling allowable

4.26.3.3 Shear Buckling Allowables

This subfunction is required to calculate the panel shear buckling allowable. This calculation is similar to that described in section 4.26.3.1.1 in that the user will be required to supply the panel shear buckling coefficient K_s to complete the calculation. The basic shear expression follows.

$$FS = \frac{\eta K_s \pi^2 E'}{12(1 - \mu^2)} \left(\frac{t}{b}\right)^2$$

where

- FS - material shear allowable
- η - plasticity correction factor
- K_s - shear buckling coefficient
- E - material compressive modulus
- t, b - geometry parameters
- μ - Poisson's ratio

Also, the user should have the ability to control the calculations for cases where the plasticity correction factor η is not to be considered (therefore, $\eta = 1.0$).

The parameters required for this calculation will be obtained from the Interim Properties and Allowables File with the exception of the shear buckling coefficient K_s and the plasticity correction factor η . The shear buckling coefficient is a function of the panel length and panel edge conditions which will be supplied by the user. Table 4.26-4 shows the shear buckling coefficient to be used with plates that have an aspect ratio a/b greater than 5.0. Figure 4.26-7 shows the shear buckling coefficient to be used with plates that have an aspect ratio less than or equal to 5.0. In general, it will be assumed that the boundary conditions used for design will almost always have all edges simply supported, and the panel aspect ratio will almost always be greater than 5.0. For these cases, the shear buckling coefficient will be assumed to be constant at 5.35. Table 5.26-5 shows the panel geometry parameters that will be required for each of the configurations. As noted in table 4.26-5, some configurations will require more than one calculation.

The shearing stress calculation will be first made by assuming that the plasticity correction factor $\eta = 1.0$. If the calculated stress is less than the material shear allowable from the Interim Properties and Allowables File, then the assumption is correct, and the calculated stress will be the shear buckling allowable for the element. If the results are higher than the material shear allowable, then an iterative procedure must be performed to determine the correct value of the plasticity correction factor η . This procedure is given below:

1. The calculated stress (for $\eta = 1.0$) is assumed to be the upper bound stress, and the material shear allowable is assumed to be the lower bound stress. The actual shear buckling allowable stress will lie between these two limits.
2. The difference between the upper and lower bound stresses will be averaged, and this difference will be added to the lower bound stress. This stress will be the assumed stress for the first iteration.
3. The modulus ratio will be calculated:

$$\frac{E_s}{E} = \frac{1}{1 + (3/7) \left(\frac{F}{F_{0.7}} \right)^{n-1}}$$

where

E_s - material secant modulus

E - material compressive modulus

F - assumed stress

$F_{0.7}$ - curve secant stress

4. The nonlinear Poisson's ratio will be calculated from the relation shown on the following page.

$$\mu_p = 0.5 - \left(\frac{E_s}{E} \right) (0.5 - \mu)$$

where

μ - elastic Poisson's ratio

5. The plasticity reduction factor will be calculated from the relation:

$$\eta = \frac{E_s}{E} \frac{(1 - \mu^2)}{(1 - \mu_p^2)}$$

6. This value will be substituted for the plasticity correction factor in the buckling equation, and the new buckling stress will be calculated. The new stress will be compared with the assumed stress.
- a. If the result is 0.1 percent or less of the assumed value, then the assumed stress will become the element shear buckling stress. This value will be stored for later use.
 - b. If the calculated stress is lower than the assumed stress, then the assumed stress will become the upper bound stress, and the material shear allowable will become the lower bound stress. The actual buckling stress will lie between these two bounds.
 - c. If the calculated stress is higher than the assumed stress then the assumed stress will become the lower bound stress, and the stress calculated for $\eta = 1.0$ will become the upper bound stress. The actual buckling stress will lie between these two bounds.
7. Once the upper and lower bound stresses are defined, the next step will be to average the difference between the two

and add this average to the lower bound stress. This stress will then become the assumed stress for the next iteration.

8. The calculations for steps 3 through 6 will be performed; next, the following tests will be performed.
 - a. If the difference between the assumed and calculated stress is 0.1 percent or less of the assumed value, then the assumed value will be the shear buckling stress for the element.
 - b. If the calculated stress is lower than the assumed stress, then the assumed stress will become the new upper bound stress.
 - c. If the calculated stress is higher than the assumed stress, then the assumed stress will become the new lower bound stress.
9. Steps 7 and 8 will be repeated until the convergence test of step 8a is satisfied. When all the calculations for the chosen panel configuration are completed, the program will compare these shear buckling stresses with the material shear allowable. The lowest absolute value of this comparison will be the shear buckling allowable for the station.

4.26.3.4 Element Section Properties

4.26.3.4.1 Stiffened Panels

For the stiffened panel concept, the section properties to be calculated will be the panel equivalent thickness \bar{t} and the panel radius of gyration ρ_G . In order to make these calculations, the user will again need to designate which panel configuration is to be analyzed. Each configuration will have a set of parameters that the program will have to calculate from the panel geometry defined in the Interim Properties and Allowables File. Table 4.26-6 shows the additional parameters required for the section properties calculation. The basic

equations to be used by the program to calculate the section properties are as follows.

$$r_{bi} = \frac{b_i}{b_s} \quad \text{and} \quad r_{ti} = \frac{t_i}{t_s}$$

$$\bar{t} = \frac{t_s \alpha}{(1 + r_{bz})} \quad \text{and} \quad \rho_G = b_s \left(\frac{\gamma - \frac{\beta^2}{\alpha}}{\alpha} \right)^{1/2}$$

where α , β , and γ are section properties and defined in Table 4.26-6.

4.26.3.4.2 Built-Up Beams

For the built-up beam concept, the program will interact with the user for coordination of the input data. The basic section properties to be calculated for the built-up beam will be the cross-sectional area, the centroid location, the moment of inertia about the beam axis, the radii of gyration about the beam axis, the polar moment of inertia, the torsional constant for the station, and the shear areas of the station. The beam geometry data will be brought into the program from the Interim Properties and Allowables File which will keep the data for each axis system separate. Starting with region 1, station 1, the program will then calculate the data required for each element. A sample beam calculation is shown in figure 4.26-8. Procedures for these calculations will be as follows.

1. Subelement area:

$$A_i = b_i t_i$$

2. Area first moment of inertia:

$$A_i C_{1i} \quad \text{and} \quad A_i C_{2i}$$

where

i - element number

C - vector distance from reference axis to centroid of element

3. Area second moment of inertia:

$$A_i C_{1i}^2 \quad \text{and} \quad A_i C_{2i}^2$$

4. Subelement moment of inertia about its own subelement axis. The user will have control at this point to select the correct subelement dimensions for the correct axis system. The basic equation to be solved is:

$$I_{10} \text{ and } I_{20} = \frac{(\text{element base length})_i (\text{element height})_i^3}{12.0}$$

5. Subelement moment of inertia about the reference axis (axes 1 and 2):

$$I_{1i} = I_{10} + A_i C_{1i}^2$$

$$I_{2i} = I_{20} + A_i C_{2i}^2$$

6. Subelement areas, first moments of inertia, and moments of inertia about the reference axis summed:

$$\sum_{i=1}^N A_i$$

$$\sum_{i=1}^N A_i C_{1i} \quad \text{and} \quad \sum_{i=1}^N A_i C_{2i}$$

$$\sum_{i=1}^N I_{1i} \quad \text{and} \quad \sum_{i=1}^N I_{2i}$$

The program will then be required to calculate the following section properties.

1. Centroid of the station from the reference axis:

$$\bar{C}_1 = \frac{\sum_{i=1}^N A_i C_{1i}}{\sum_{i=1}^N A_i} \quad \text{and} \quad \bar{C}_2 = \frac{\sum_{i=1}^N A_i C_{2i}}{\sum_{i=1}^N A_i}$$

where

- A_i - subelement area
- C_{1i}, C_{2i} - centroid of elements
- N - number of subelements

2. Section moment of inertia about the neutral axis:

$$I_{1na} = \sum_{i=1}^N I_{1i} - \bar{C}_1^2 \sum_{i=1}^N A_i$$

$$I_{2na} = \sum_{i=1}^N I_{2i} - \bar{C}_2^2 \sum_{i=1}^N A_i$$

3. Radius of gyration about the neutral axis:

$$\rho_1 = \sqrt{\frac{I_{1na}}{\sum_{i=1}^N A_i}} \quad \text{and} \quad \rho_2 = \sqrt{\frac{I_{2na}}{\sum_{i=1}^N A_i}}$$

4. Polar moment of inertia for the section:

$$I_{12} = I_{1na} + I_{2na}$$

5. Each subelement aspect ratio for the section torsional constant:

$$S_i = \frac{b_i}{t_i}$$

6. Each subelement torsion factor B_i will be determined from figure 4.26-9.

7. Subelement torsional constant:

$$J_i = B_i b_i t_i^3$$

8. The subelement torsional constants summed:

$$J = \sum_{i=1}^N J_i$$

Steps 5 through 8 will only need to be calculated using data for one of the reference axis.

The following method to determine the section area factors for shear will only be an approximate method due to the idealization of the section into rectangular subelements. The user will interact with the program to select the subelements containing shear.

1. From a list of subelements for a station, the user will select the elements that will resist shear with respect to the section axis system.

2. The selected subelement areas for shear will be gathered and summed.

$$A_{1s} = \sum_{i=1}^N A_{1i} \quad \text{and/or} \quad A_{2s} = \sum_{i=1}^N A_{2i}$$

3. The area factors will be determined from the ratio of the subelement shear areas and the total section area.

$$K_1 = \frac{A_{1s}}{A} \quad \text{and/or} \quad K_2 = \frac{A_{2s}}{A}$$

4.26.3.5 Column Allowables

The program must provide the user the option of continuing with the subfunction or returning to the ISAS Executive at this point. If processing is to be continued, the program will generate the column allowable curve for the identified material. The data required to generate this curve will come from the Interim Properties and Allowables File and the calculations described in the preceding sections. The curve to be developed will be the result of the two following equations.

1. Johnson equation: $\sigma_{CR} = F - \frac{F^2(L/\rho)^2}{4C\pi^2E}$

2. Euler equation: $\sigma_{CR} = \frac{C\pi^2E}{(L/\rho)^2}$

where

E - material compressive modulus

F - configuration cut-off stress

C - column end fixity coefficient

σ_{CR} - critical stress

- ρ - radius of gyration
L - length of panel or column

The cut-off stress to be used with the Johnson equation will be the lower of the two values of the buckling stress F_C and crippling allowable stress F_{CC} . These values will be obtained from the Section Properties and Allowables File. The program must compare the two values and then use the lowest absolute value with the Johnson equation.

The user will input the value of the fixity coefficient C for the curve. A list of values for the coefficient is shown in table 4.26-7 for various end conditions. The program will be required to provide a two dimensional plot showing the critical stress σ_{CR} as the ordinate and the slenderness ratio L/ρ as the abscissa. A sample of the plot is shown in figure 4.26-10. As an aid in plotting this curve from the two previous equations, the tangency point is given by the following relation:

$$L/\rho = 4.44 \sqrt{\frac{CE}{F}}$$

where

- L/ρ - slenderness ratio
C - column end fixity coefficient
F - configuration cut-off stress
E - material compressive modulus

4.26.3.5.1 Stiffened Panel

There will be two methods to calculate the panel compression allowable. The user should have a choice of which calculation method is to be used.

4.26.3.5.1.1 EMERO AND SPUNT METHOD. This method can be performed only on those panel configurations having properties determined by table 4.26-6. The column length L and section radius of gyration ρ will be obtained from the Section Properties and Allowables File. The function will then calculate the slenderness ratio L/ρ for the panel. The program then must either retrieve the column buckling stress from the column allowable curve, which has been generated previously (section 4.26.3.5), or allow the column allowable stress to be calculated from the previous equations. This choice will allow the user to change the end fixity coefficient C manually. The method should be performed in the following steps.

1. The curve tangent point will be calculated from the relation:

$$L/\rho = 4.44 \sqrt{\frac{CE}{F}}$$

where

E - material compressive modulus

F - configuration cut-off stress

C - end fixity coefficient

2. If the slenderness ratio for the panel is less than the slenderness ratio calculated in step 1, then the Johnson equation will be used to calculate the column allowable.

$$\sigma_{CR} = F - \frac{F^2 (L/\rho)^2}{4C\pi^2 E}$$

3. If the slenderness ratio for the panel is equal to or greater than the slenderness ratio calculated in step 1, then the Euler equation will be used to calculate the column allowable stress.

$$\sigma_{CR} = \frac{C\pi^2 E}{(L/\rho)^2}$$

The value of the column allowable stress σ_{CR} for the panel should then be stored in the Structural Allowables Data File as the value for the allowable compressive stress.

4.26.3.5.1.2 EFFECTIVE SKIN METHOD. This method will allow the user to calculate the column allowable stress from the section geometry parameters which will be stored in the Section Properties and Allowables File. The steps used in this method are:

1. The radius of gyration of the stiffener cross-section ρ_{st} about the centroidal axis and the panel length L will be obtained from the Section Properties and Allowables File.
2. The slenderness ratio of the stiffener alone L/ρ_{st} will be calculated.
3. With the slenderness ratio L/ρ_{st} , the critical stress for the stringer will be determined using the column allowable curve (section 4.26.3.5). It should be noted that the previous method used to calculate the column stress from the column equations can be used here; this will allow the user to input the end fixity coefficient.
4. The effective width W_e of the panel sheet acting with the stiffener from the relation will be computed using the critical stress from step 3.

$$W_e = 0.85t_s \sqrt{\frac{E}{\sigma_{CR}}}$$

where

t_s - sheet thickness obtained from the Section Properties and Allowables File

σ_{CR} - critical stress obtained from step 3

If the effective sheet width W_e is larger than the stiffener spacing b_s , the effective sheet width will be set equal to the stiffener spacing.

5. The following parameter will be calculated:

$$d = \bar{c} + \frac{t_s}{2.0}$$

where

d - distance from the stiffener centroid to the middle surface of the sheet

\bar{c} - location of stiffener centroid from the reference axis (see figure 4.26-8)

For single line fastener attachment:

$$z = \frac{2W_e t_s}{A_{st}}$$

For double line fastener attachment:

$$z = \frac{4W_e t_s}{A_{st}}$$

where

z - effective skin width parameter

A_{st} - area of stiffener

W_e - effective width of the panel sheet

t_s - sheet thickness

6. The radius of gyration for the skin and stringer combination will be calculated from the following equation:

$$\rho = \rho_{st} \left\{ \frac{1 + \left[1 + (d/\rho_{st})^2 Z \right]}{(1 + Z)^2} \right\}^{1/2}$$

where

Z - effective skin width parameter

d - value calculated in step 5

ρ_{st} - radius of gyration of stiffener

7. The new slenderness ratio will be computed using the radius of gyration ρ from step 6.
8. The critical buckling stress will be determined from the curve generated in section 4.26.3.5, or it will be calculated from the previous methods (i.e., Johnson or Euler equation).
9. The buckling stress from step 8 will be compared with the stress from step 3. If the difference is greater than 1 percent of the stress from step 3, then steps 4 through 8 will be repeated until the difference becomes equal to or less than 1 percent. When repeating these steps, the stress calculated in step 8 will be used to calculate the new effective skin width parameter Z. Convergence generally will occur after two or three iterations.
10. The column allowable stress will be calculated from the following relations.

For single line attachments:

$$P_{CR} = \sigma_{CR} (A_{st} + 2W_e t_s) + FC_{ss} (b_s - 2W_e) t_s$$

$$\sigma_{\text{allow}} = \frac{P_{\text{CR}}}{(A_{\text{st}} + 2W_e t_s) + t_s (b_s - 2W_e)}$$

For double line attachments:

$$P_{\text{CR}} = \sigma_{\text{CR}} (A_{\text{st}} + 4W_e t_s) + FC_{\text{ss}} (b_s - 4W_e) t_s$$

$$\sigma_{\text{allow}} = \frac{P_{\text{CR}}}{(A_{\text{st}} + 4W_e t_s) + t_s (b_s - 4W_e)}$$

where

P_{CR} – calculated allowable force

A_{st} – stiffener area

W_e – effective width

t_s – sheet thickness

σ_{CR} – critical buckling stress

σ_{allow} – column allowable stress

b_s – stiffener spacing

FC_{ss} – local buckling stress of skin between stiffeners

This calculated column allowable stress value should then be stored in the Structural Allowable Data File as the value for allowable compressive stress.

4.26.3.5.2 Beam Sections

This section of the program should obtain the beam or section length and the section radius of gyration from the Section Properties and Allowables File and should allow the user to select which beam axis radius of gyration is to be used. The program must calculate the slenderness ratio L/ρ and, using the curve generated in section 4.26.3.5, determine the column allowable stress. The user must have the capability to input new column end fixity

coefficient and calculate the stress directly (using the Johnson or Euler equations).

4.26.4 OUTPUT

The output from this function will consist of three data files (Interim Properties and Allowables File, Section Properties and Allowables File, and Structural Allowable Data File) tabulation of data from the input and output files, and plots of data from the input and output files. The Interim Properties and Allowables File and the Section Properties and Allowables File will be used as intermediate storage and will not be used by any other part of ISAS. A description of the contents of these files can be found in the appendix of this document. The final product of this function will be the Structural Allowable Data File. The file will contain the following information:

- Section identification number
- Section type identification
- X, Y, and Z coordinates of the section
- Allowable compressive stress (F_c)
- Allowable shear stress (F_s)
- Allowable tension stress (F_t)

It is also required that this file provide space for the following parameters:

- Allowable torsion stress (F_{tor})
- Allowable bending stress (F_b)
- Allowable stress due to pressure (F_p)
- Allowable biaxial stress field (F_x, F_y)

Phase B of ISAS will not have the ability to calculate these parameters. (This function will allow for them to be input

manually.) At some time in the future, it is expected that this function will be modified to compute these measurements.

The tabulations required will be listings of the contents of the data files versus the section identification numbers. An example of this type of tabulation for the Interim Properties and Allowables File is shown in figure 4.26-2. As data are displayed in this tabulation, the user must have the capability to modify any of the data displayed.

Figure 4.26-10 is an example of one of the plot types to be created by the program. As an example, this particular plot should allow the user to specify the section identification number and then display the critical stress versus the slenderness ratio.

The program should allow the user to view the model as a three-dimensional plot and superimpose on this plot various section properties requested by the user. Figures 4.26-11 and 4.26-12 show examples of this plot in both the stiffened panel concept and the beam concept.

Figure 4.26-13 is an example of an interaction curve. The program should provide the capability to create plots of this type for each of the equations shown in table 4.26-8.

The ratio to be calculated has the following form.

$$R = \frac{\text{applied stress}}{\text{allowable stress}}$$

The user will be required to supply the applied stress, and the Structural Allowable Data File will supply the allowable stress. The subscript associated with the ratio R denotes the type of stress involved; e.g., b denotes bending, tor denotes torsion.

The program will also have the capability to calculate the missing applied stress from the equations shown in table 4.26-8 provided the other applied stresses are given.

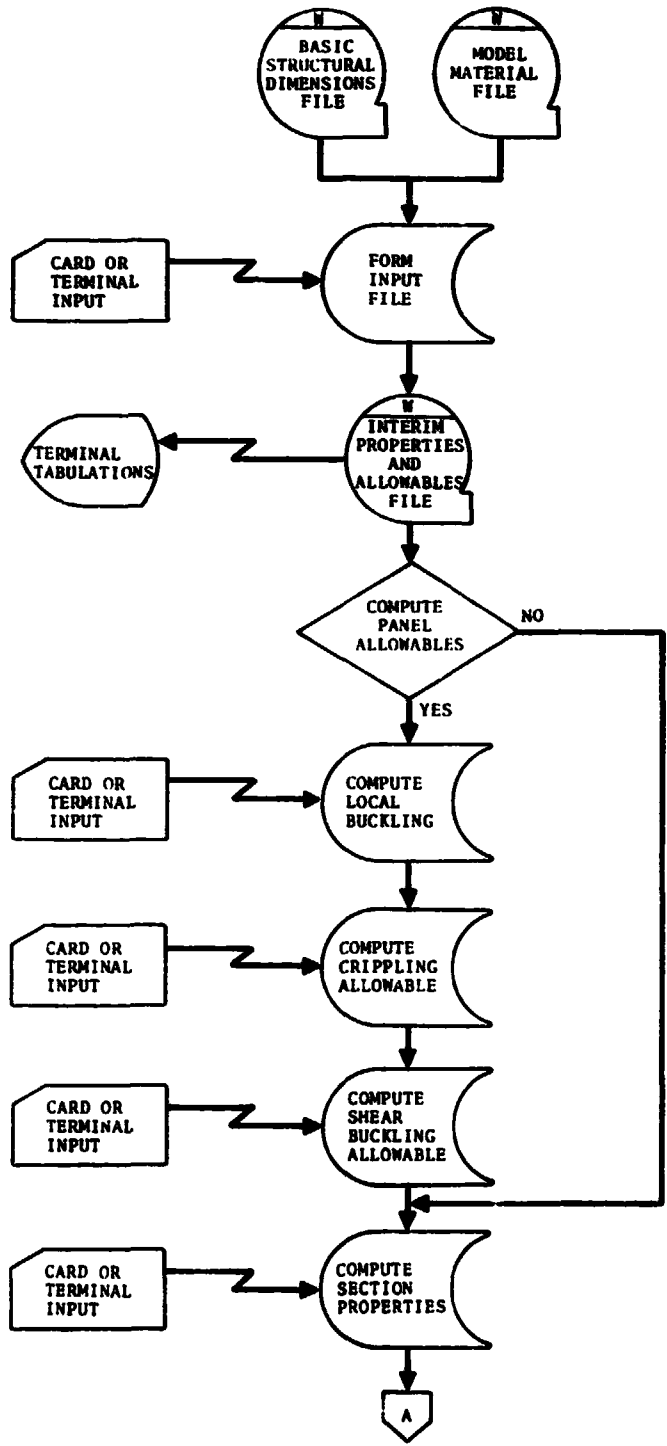
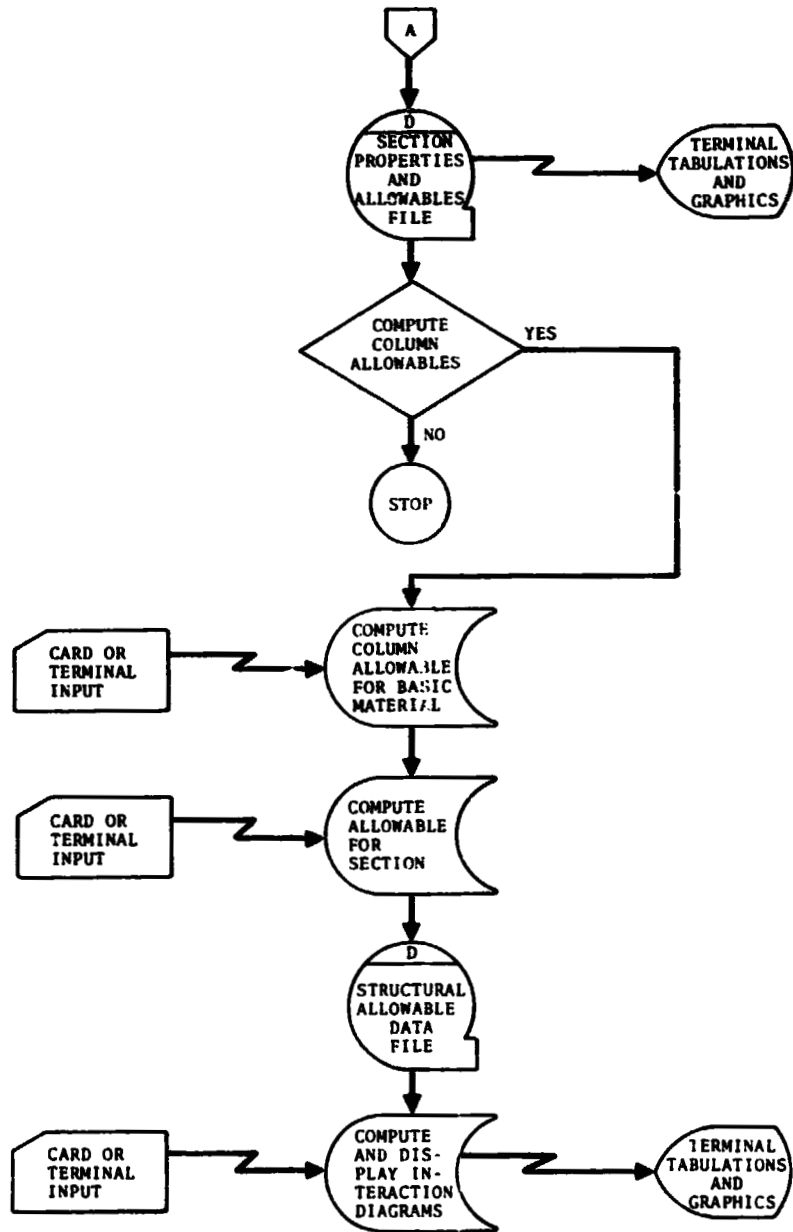

Figure 4.26-1. - Data flow diagram for Properties and Allowables.

ORIGINAL PAGE IS
OF POOR QUALITY



ORIGINAL PAGE IS
OF POOR QUALITY

Figure 4.26-1. - Data flow diagram for Properties and Allowables (concluded).

SECTION TYPE - 12 HAT SECTION STIFFENED

STATION NUMBER	E	FTU	POISSON'S RATIO	FC	FS	E _s	E _t	n	F _{0.7}
(14)	(F10.0)	(F10.0)	(F5.3)	(F10.0)	(F10.0)	(F10.0)	(F10.0)	(F10.2)	(F10.0)

Note:

- E - material compressive modulus
- FTU - material tensile ultimate stress
- FC - material compressive yield stress
- FS - material shear stress
- E_s - material secant modulus
- E_t - material tangent modulus
- n - curve shape factor
- F_{0.7} - curve secant stress

Figure 4.26-2. - Example of tabulation format for Interim Properties and Allowables File.

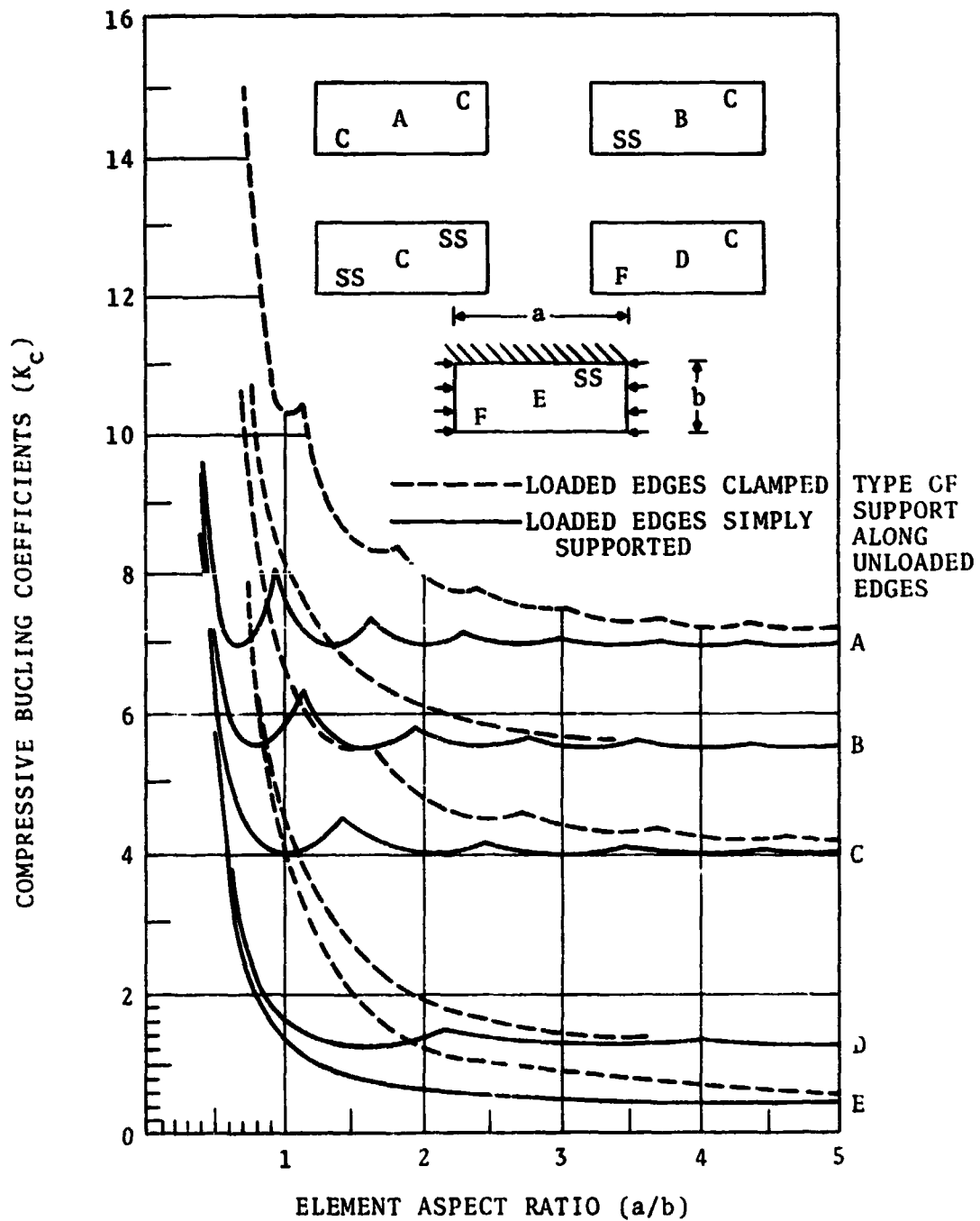

where

SS - simple support
 C - clamped
 F - free

Figure 4.26-3. - Compressive buckling coefficients for flat plates.

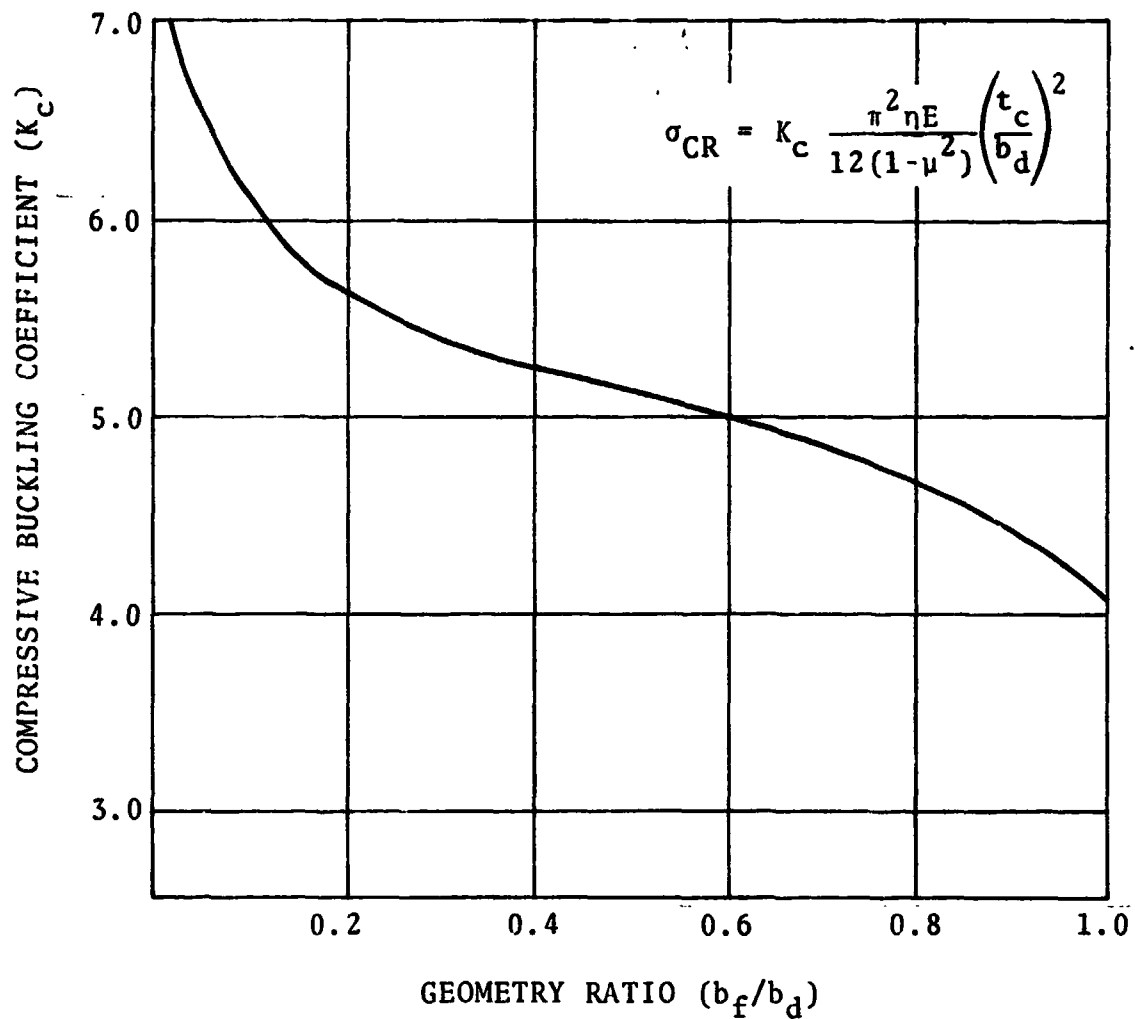

where

- η - plasticity correction factor
- E - material compressive modulus
- b_f, t_c, b_d - geometry parameters
- K_c - compressive buckling coefficient
- μ - Poisson's ratio
- σ_{CR} - critical stress

Figure 4.26-4. - Trapezoidal corrugation local compressive buckling coefficient.

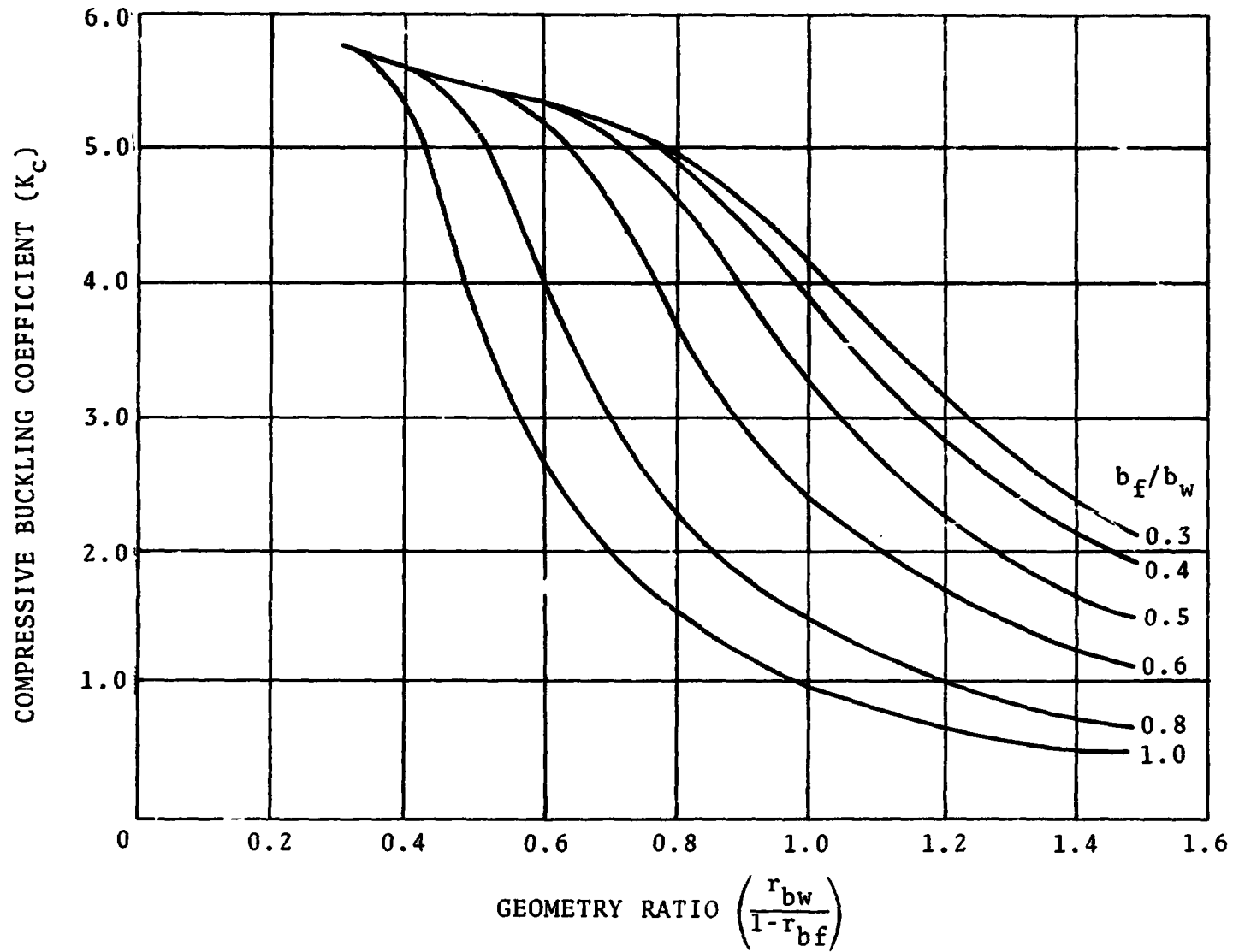

Figure 4.26-5. — Compressive buckling coefficient for hat stiffeners based on constant t_w geometry parameter.

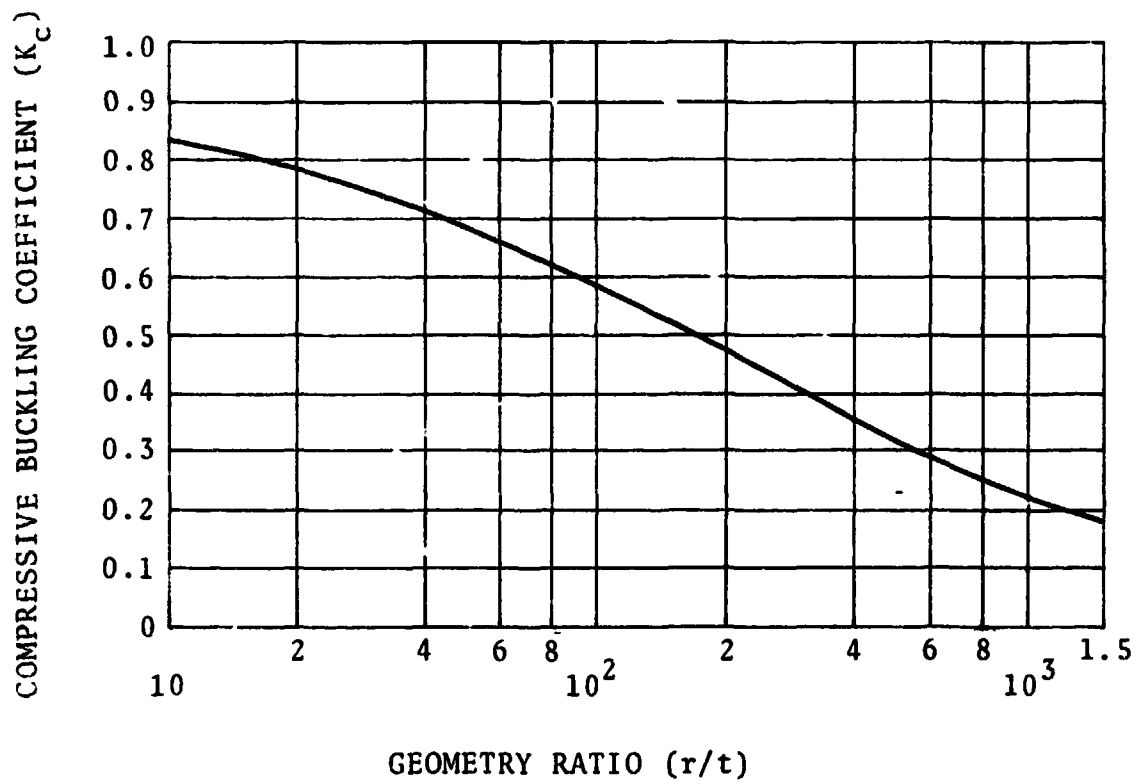

Figure 4.26-6. - Compressive buckling coefficient for cylinders.

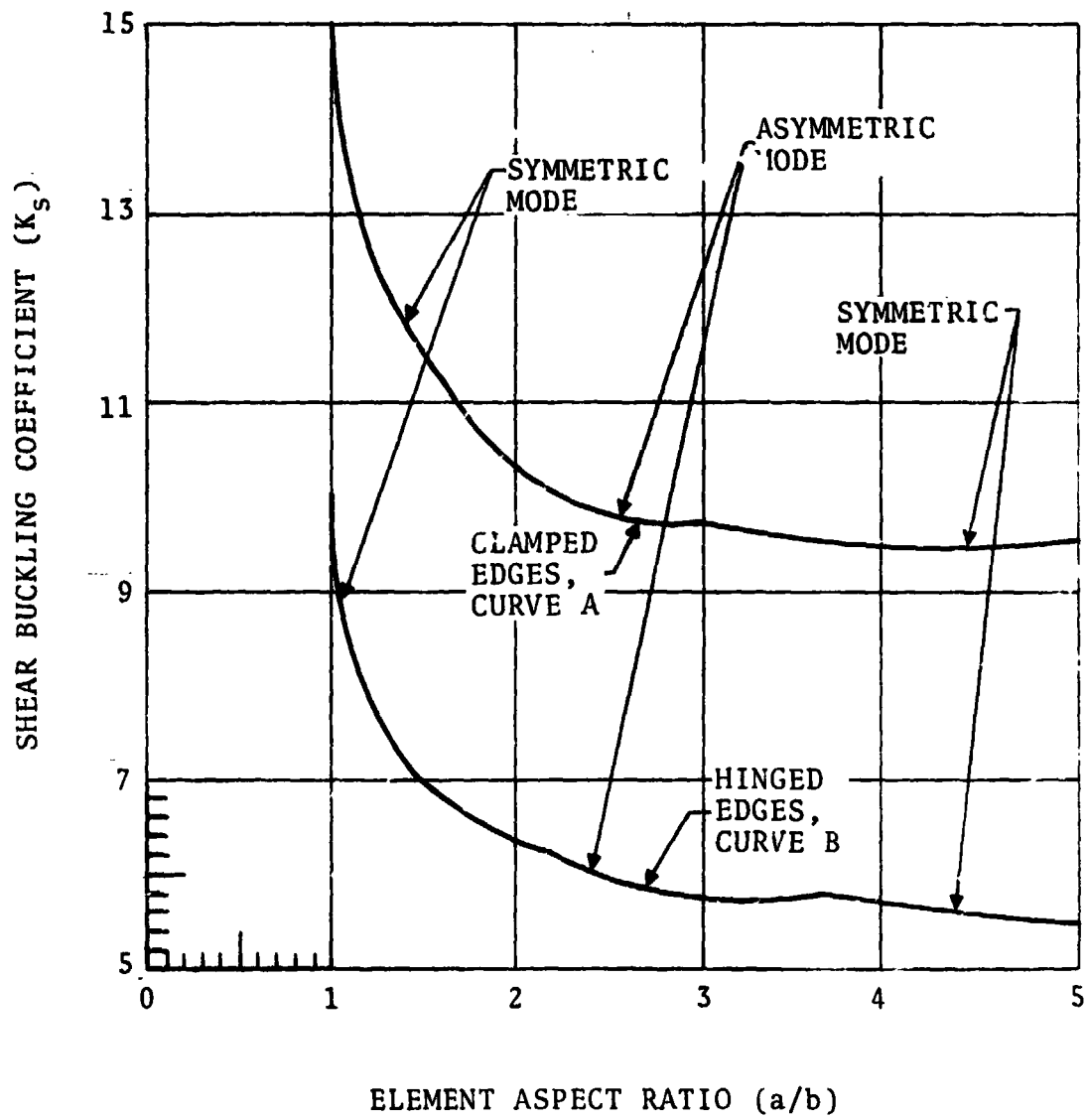
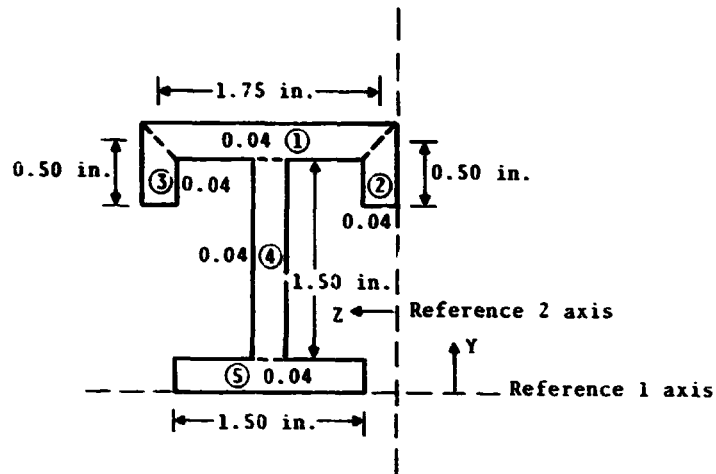

Figure 4.26-7. — Shear buckling coefficient for flat plates.



REFERENCE 1 AXIS

Element	b	t	A = bt	C ₁	AC ₁	AC ₁ ²	I ₁₀	I ₁ = I ₁₀ + AC ₁ ²
1	1.75	0.040	0.070	1.56	0.1092	0.1703	0	0.1703
2	0.50	0.040	0.020	1.31	0.0262	0.0343	0.0004	0.0347
3	0.50	0.040	0.020	1.31	0.0262	0.0343	0.0004	0.0347
4	1.50	0.040	0.060	0.79	0.0474	0.0374	0.01125	0.04595
5	1.50	0.040	0.060	0.02	0.0012	0	0	0
Σ			0.230		0.2102			0.28565

$$\bar{c}_1 = \frac{\Sigma AC_1}{\Sigma A} = \frac{0.2102}{0.23} = 0.9139; \rho_1 = \sqrt{\frac{I_{1NA}}{A}} = \sqrt{\frac{0.09354}{0.230}} = 0.6377$$

$$I_{1NA} = I_1 - AC_1^2 = 0.28565 - (0.23)(0.9139)^2 = 0.09354$$

REFERENCE 2 AXIS

Element	b	t	A = bt	C ₂	AC ₂	AC ₂ ²	I ₂₀	I ₂ = I ₂₀ + AC ₂ ²
1	1.75	0.040	0.070	0.895	0.06265	0.05607	0.01786	0.07393
2	0.50	0.040	0.020	0.020	0.0004	0	0	0
3	0.50	0.040	0.020	1.770	0.0354	0.06265	0	0.06266
4	1.50	0.040	0.060	0.895	0.0537	0.04806	0	0.04806
5	1.50	0.040	0.060	0.895	0.0537	0.04806	0.01125	0.05931
Σ			0.230		0.20585			0.24396

$$\bar{c}_2 = \frac{\Sigma AC_2}{\Sigma A} = \frac{0.20585}{0.230} = 0.895$$

$$I_{2NA} = I_2 - AC_2^2 = 0.24396 - (0.23)(0.895)^2 = 0.05972$$

$$I_{12} = I_1 + I_2 = 0.09354 + 0.05972 = 0.15326$$

$$\rho_2 = \sqrt{\frac{I_{2NA}}{A}} = \sqrt{\frac{0.05972}{0.230}} = 0.5096$$

ORIGINAL PAGE IS
OF POOR QUALITY

Figure 4.26-8. - Sample beam calculations.

4-297

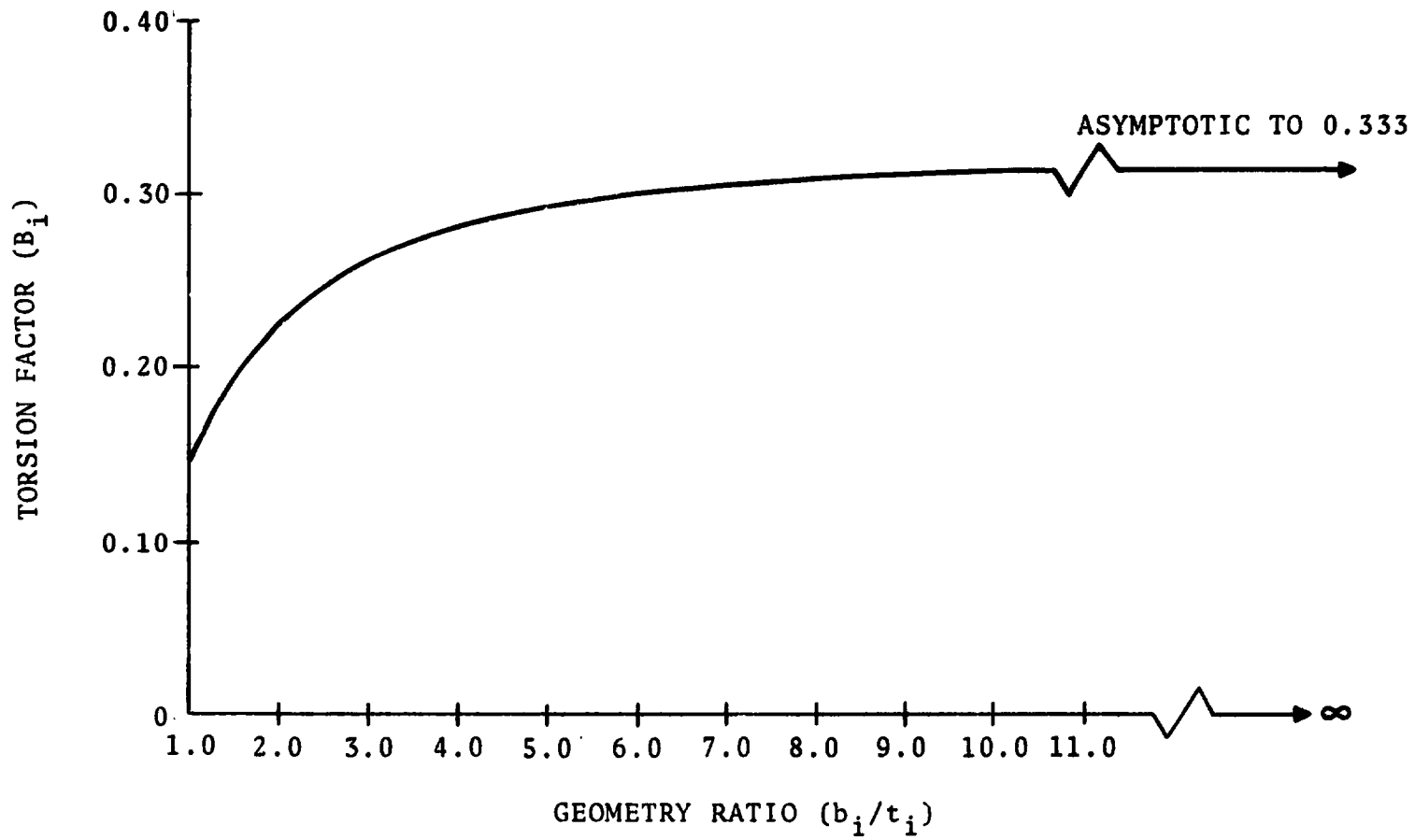

Figure 4.26-9. - Torsion factor for rectangular elements.

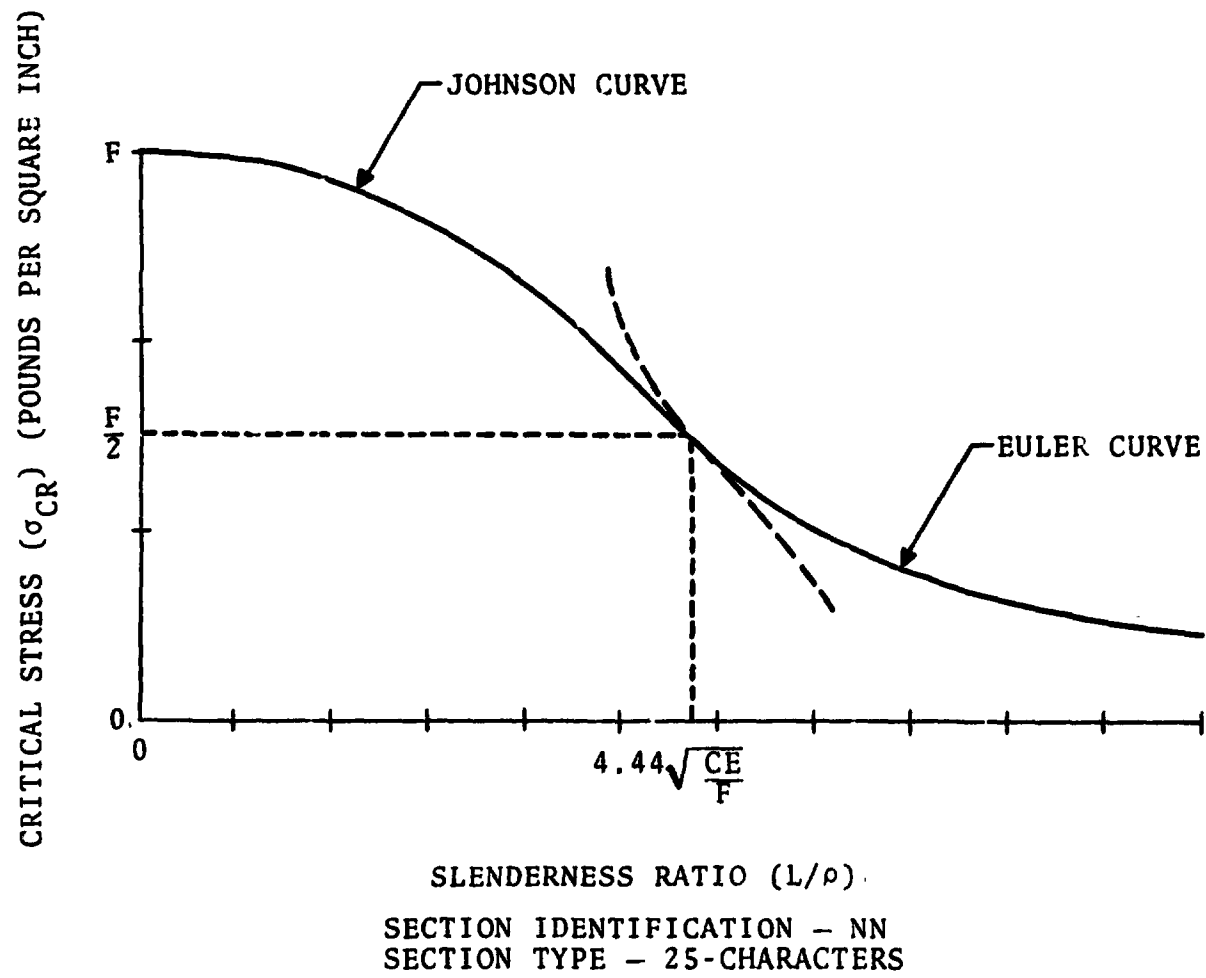

Figure 4.26-10. - Example of column allowable curve.

4-299

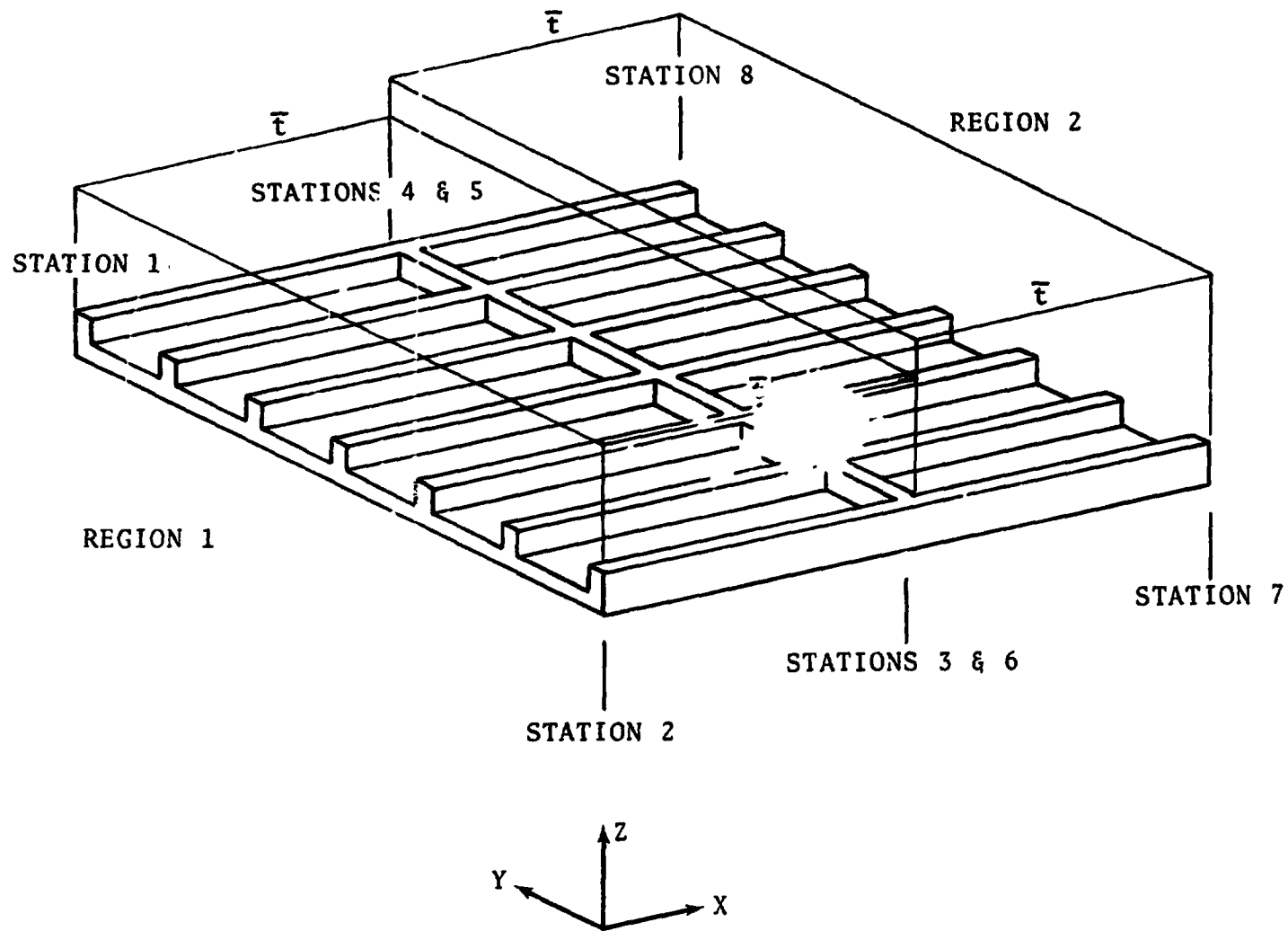

Figure 4.26-11. - Stiffened panel concept.

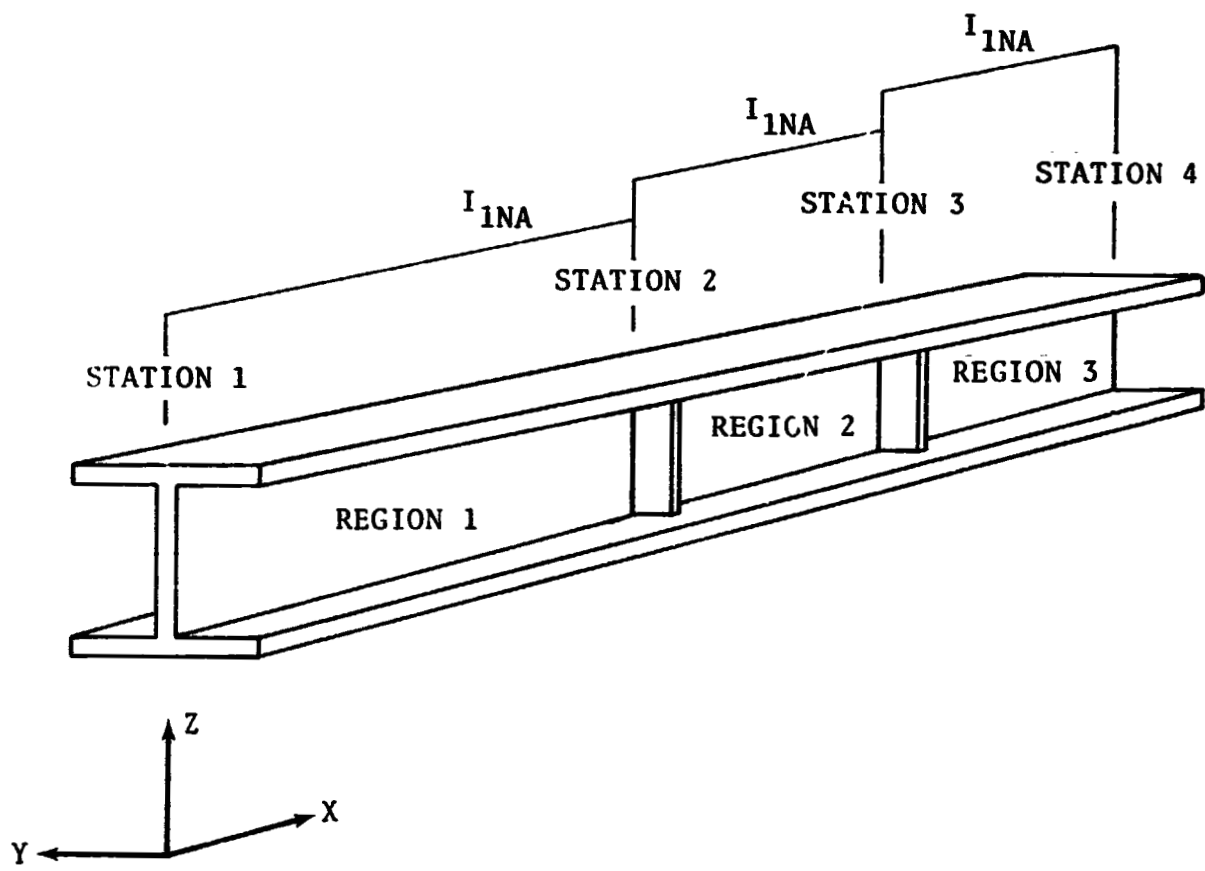

Figure 4.26-12. - Beam concept.

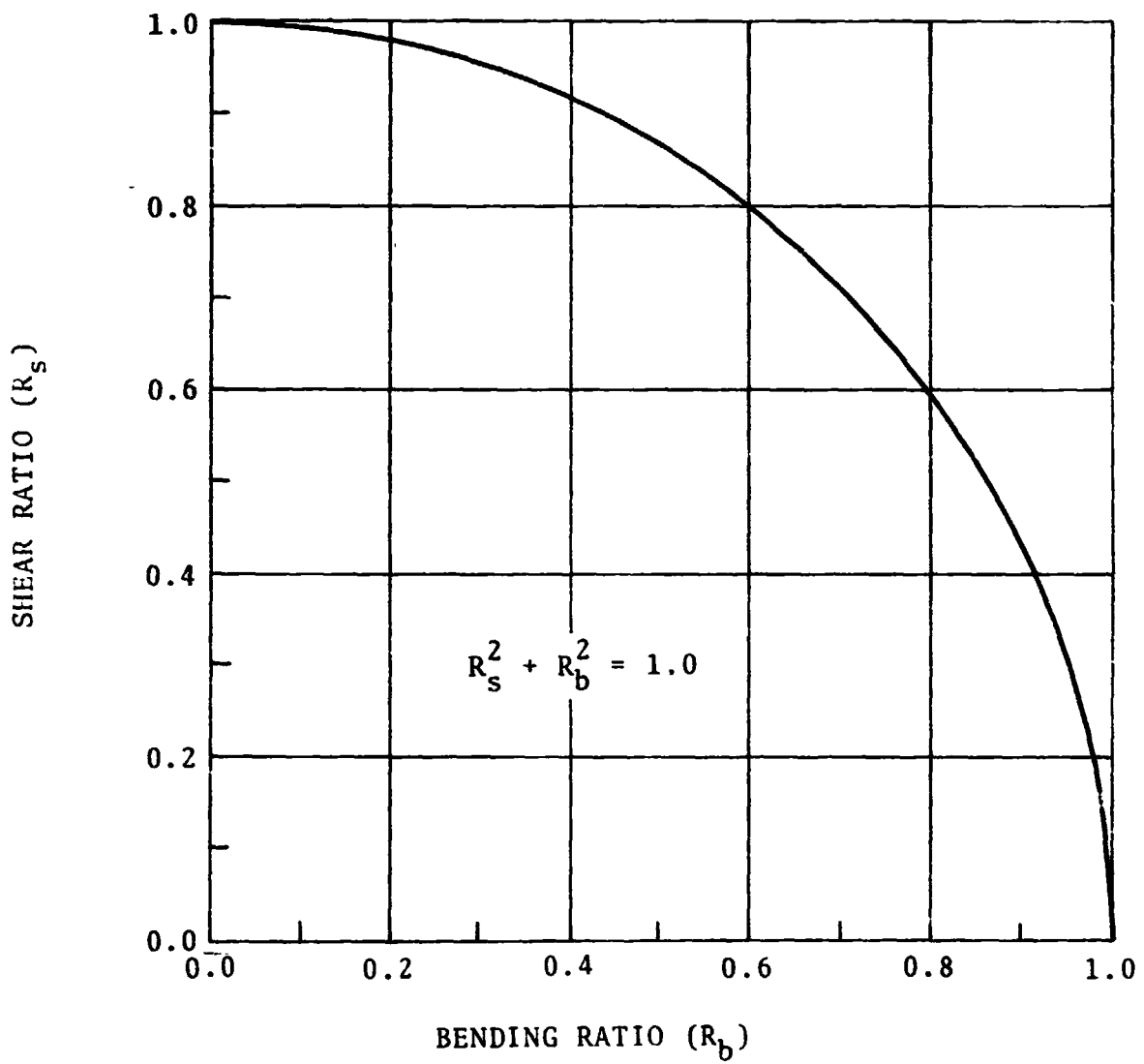

Figure 4.26-13. - Example of interaction curve for combined shear and bending.

TABLE 4.26-1. - PARAMETERS FOR LOCAL BUCKLING

Panel Configuration	Element 1	Element 2	Element 3	Element 4	Element 5	Element 6
1 Integral Stiffened	FC_{tw} for b_w, t_w If $a/b_w \geq 5.0$, use $K_c = 0.43$ If $a/b_w < 5.0$, use curve E, fig. 4.26-3	FC_{23} for b_y, t_y If $a/b_y \geq 5.0$, use $K_c = 4.0$ If $a/b_y < 5.0$, use curve C, fig. 4.26-3				
2 Z-Stiffened	FC_{11} for b_f, t_f If $a/b_f \geq 5.0$, use $K_c = 0.43$ If $a/b_f < 5.0$, use curve E, fig. 4.26-3	FC_{tw} for b_w, t_w If $a/b_w \geq 5.0$, use $K_c = 4.0$ If $a/b_w < 5.0$, use curve C, fig. 4.26-3	FC_{23} for b_y, t_y If $a/b_y \geq 5.0$, use $K_c = 4.0$ If $a/b_y < 5.0$, use curve C, fig. 4.26-3			
3 Integral Z-Stiffened	FC_{11} for b_f, t_f If $a/b_f \geq 5.0$, use $K_c = 0.43$ If $a/b_f < 5.0$, use curve E, fig. 4.26-3	FC_{tw} for b_w, t_w If $a/b_w \geq 5.0$, use $K_c = 4.0$ If $a/b_w < 5.0$, use curve C, fig. 4.26-3	FC_{23} for b_y, t_y If $a/b_y \geq 5.0$, use $K_c = 4.0$ If $a/b_y < 5.0$, use curve C, fig. 4.26-3			
4 Integral T-Stiffened	FC_{11} for $b_f/2, t_f$ If $a/b_f/2 \geq 5.0$, $K_c = 0.43$ If $a/b_f/2 < 5.0$, use curve E, fig. 4.26-3	FC_{tw} for b_w, t_w If $a/b_w \geq 5.0$, use $K_c = 4.0$ If $a/b_w < 5.0$, use curve C, fig. 4.26-3	FC_{23} for b_y, t_y If $a/b_y \geq 5.0$, use $K_c = 4.0$ If $a/b_y < 5.0$, use curve C, fig. 4.26-3			
5 J-Stiffened	FC_{11} for b_f, t_f If $a/b_f \geq 5.0$, use $K_c = 0.43$ If $a/b_f < 5.0$, use curve E, fig. 4.26-3	FC_{tw} for b_w, t_w If $a/b_w \geq 5.0$, use $K_c = 4.0$ If $a/b_w < 5.0$, use curve C, fig. 4.26-3	FC_{23} for b_y, t_y If $a/b_y \geq 5.0$, use $K_c = 4.0$ If $a/b_y < 5.0$, use curve C, fig. 4.26-3			
6 Straight Y-Stiffened	FC_{11} for b_f, t_f If $a/b_f \geq 5.0$, use $K_c = 0.43$ If $a/b_f < 5.0$, use curve E, fig. 4.26-3	FC_{tw} for b_w, t_w If $a/b_w \geq 5.0$, use $K_c = 4.0$ If $a/b_w < 5.0$, use curve C, fig. 4.26-3	FC_{23} for b_y, t_y If $a/b_y \geq 5.0$, use $K_c = 4.0$ If $a/b_y < 5.0$, use curve C, fig. 4.26-3	FC_{1w} for b_f, t_w If $a/b_f \geq 5.0$, use $K_c = 0.43$ If $a/b_f < 5.0$, use curve E, fig. 4.26-3	FC_{23} for b_y, t_y If $a/b_y \geq 5.0$, use $K_c = 4.0$ If $a/b_y < 5.0$, use curve C, fig. 4.26-3	
7 Straight Y-T Stiffened	FC_{11} for b_f, t_f If $a/b_f \geq 5.0$, use $K_c = 0.43$ If $a/b_f < 5.0$, use curve E, fig. 4.26-3	FC_{11} for b_f, t_f If $a/b_f \geq 5.0$, use $K_c = 4.0$ If $a/b_f < 5.0$, use curve C, fig. 4.26-3	FC_{tw} for b_w, t_w If $a/b_w \geq 5.0$, use $K_c = 4.0$ If $a/b_w < 5.0$, use curve C, fig. 4.26-3	FC_{23} for b_y, t_y If $a/b_y \geq 5.0$, use $K_c = 4.0$ If $a/b_y < 5.0$, use curve C, fig. 4.26-3	FC_{1w} for b_f, t_w If $a/b_f \geq 5.0$, use $K_c = 0.43$ If $a/b_f < 5.0$, use curve E, fig. 4.26-3	FC_{23} for b_y, t_y If $a/b_y \geq 5.0$, use $K_c = 4.0$ If $a/b_y < 5.0$, use curve C, fig. 4.26-3
8 Curved Y-T Stiffened	FC_{11} for b_f, t_f If $a/b_f \geq 5.0$, use $K_c = 0.43$ If $a/b_f < 5.0$, use curve E, fig. 4.26-3	FC_{11} for b_f, t_f If $a/b_f \geq 5.0$, use $K_c = 4.0$ If $a/b_f < 5.0$, use curve C, fig. 4.26-3	FC_{tw} for b_w, t_w If $a/b_w \geq 5.0$, use $K_c = 4.0$ If $a/b_w < 5.0$, use curve C, fig. 4.26-3	FC_{23} for b_y, t_y If $a/b_y \geq 5.0$, use $K_c = 4.0$ If $a/b_y < 5.0$, use curve C, fig. 4.26-3	FC_{1w} for b_f, t_w If $a/b_f \geq 5.0$, use $K_c = 0.43$ If $a/b_f < 5.0$, use curve E, fig. 4.26-3	FC_{23} for b_y, t_y If $a/b_y \geq 5.0$, use $K_c = 4.0$ If $a/b_y < 5.0$, use curve C, fig. 4.26-3

ORIGINAL PAGE IS
OF POOR QUALITY

TABLE 4.26-1. - PARAMETERS FOR LOCAL BUCKLING - Concluded

Panel Configuration	Element 1	Element 2	Element 3	Element 4	Element 5	Element 6
9 Trapezoidal Corrugation Semisandwich	FC_{tc} for b_f, t_c If $a/b_f \geq 5.0$, use $K_c = 4.0$ If $a/b_f < 5.0$, use curve C, fig. 4.26-3	FC_{dc} for b_d, t_c If $a/b_d \geq 5.0$, use $K_c = 4.0$ If $a/b_d < 5.0$, use curve C, fig. 4.26-3	FC_{ff} for b_f, t_f If $a/b_f \geq 5.0$, use $K_c = 4.0$ If $a/b_f < 5.0$, use curve C, fig. 4.26-3	FC_{fd} for b_f, b_d, t_c Calculate b_f/b_d and use fig. 4.26-4		
10 Truss Core Semisandwich	FC_{dc} for b_d, t_c If $a/b_d \geq 5.0$, use $K_c = 4.0$ If $a/b_d < 5.0$, use curve C, fig. 4.26-3	FC_{ff} for b_f, t_f If $a/b_f \geq 5.0$, use $K_c = 4.0$ If $a/b_f < 5.0$, use curve C, fig. 4.26-3				
11 Semitrapezoidal Corrugation Semisandwich	FC_{fd} for b_f, b_d, t_c Calculate b_f/b_d and use fig. 4.26-4	FC_{tc} for b_f, t_c If $a/b_f \geq 5.0$, use $K_c = 4.0$ If $a/b_f < 5.0$, use curve C, fig. 4.26-3	FC_{dc} for b_d, t_c If $a/b_d \geq 5.0$, use $K_c = 4.0$ If $a/b_d < 5.0$, use curve C, fig. 4.26-3	FC_{ff} for b_f, t_f If $a/b_f \geq 5.0$, use $K_c = 4.0$ If $a/b_f < 5.0$, use curve C, fig. 4.26-3		
12 Hat Section Stiffened	FC_{ffw} for b_f, b_w, t_w, t_f Calculate b_f/b_w and $t_w/(1 - t_f)$, then use fig. 4.26-5	FC_{zfw} for b_z, b_f, t_w If $a/(b_z - b_f) \geq 5.0$, use $K_c = 4.0$ If $a/(b_z - b_f) < 5.0$, use curve C, fig. 4.26-3	FC_{ffw} for b_w, t_w If $a/b_w \geq 5.0$, use $K_c = 4.0$ If $a/b_w < 5.0$, use curve C, fig. 4.26-3	FC_{ff} for b_f, t_f If $a/b_f \geq 5.0$, use $K_c = 0.43$ If $a/b_f < 5.0$, use curve E, fig. 4.26-3	FC_{z5} for b_z, t_5 If $a/b_z \geq 5.0$, use $K_c = 4.0$ If $a/b_z < 5.0$, use curve C, fig. 4.26-3	FC_{ff} for b_f, t_f If $a/b_f \geq 5.0$, use $K_c = 4.0$ If $a/b_f < 5.0$, use curve C, fig. 4.26-3
13 Trapezoidal Corrugation	FC_{fd} for b_f, b_d, t_c Calculate b_f/b_d , use fig. 4.26-4	FC_{tc} for b_f, t_c If $a/b_f \geq 5.0$, use $K_c = 4.0$ If $a/b_f < 5.0$, use curve C, fig. 4.26-3	FC_{dc} for b_d, t_c If $a/b_d \geq 5.0$, use $K_c = 4.0$ If $a/b_d < 5.0$, use curve C, fig. 4.26-3			
14 Truss Core Corrugation	FC_{dc} for b_d, t_c If $a/b_d \geq 5.0$, use $K_c = 4.0$ If $a/b_d < 5.0$, use curve C, fig. 4.26-3					
15 Semicircle Corrugation Semisandwich	FC_{Rt} for R, t_c K_c obtained from fig. 4.26-6	FC_{ff} for b_f, t_f If $a/b_f \geq 5.0$, use $K_c = 4.0$ If $a/b_f < 5.0$, use curve C, fig. 4.26-3				

TABLE 4.26-2. - BUCKLING COEFFICIENT FOR
INFINITE PLATES IN COMPRESSION

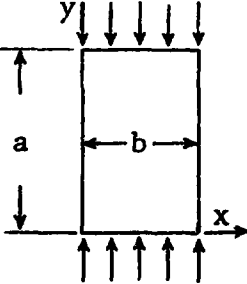
Loading	Edge support	Coefficient
<p style="text-align: center;">Compression</p> 	Simple support on all edges	$K_c = 4.0^*$
	Clamped on all edges	$K_c = 6.98^*$
	Simple support on $y = 0, y = a, x = 0$ Free on $x = b$	$K_c = 0.43^\dagger$
	Clamped on $y = 0, y = a, x = 0$ Free on $x = b$	$K_c = 1.28^\dagger$

*National Advisory Committee on Aeronautics, Report 733.

†National Advisory Committee on Aeronautics, Report 734.

TABLE 4.26-3. -- PANEL CRIPPLING STRESS RELATIONS

Panel Configuration	Crippling Stress Calculation
1 Integrally Stiffened	$FCC = \frac{(FC_{ww})(b_w)(t_w)}{(b_w)(t_w)} = FC_{ww}$
2 Z-Stiffened	$FCC = \frac{2(FC_{ff})(b_f)(t_f) + (FC_{ww})(b_w)(t_w)}{(2)(b_f)(t_f) + (b_w)(t_w)}$
3 Integral Z	$FCC = \frac{(FC_{ff})(b_f)(t_f) + (FC_{ww})(b_w)(t_w)}{(b_f)(t_f) + (b_w)(t_w)}$
4 Integral T	$FCC = \frac{(FC_{ff})(b_f)(t_f) + (FC_{ww})(b_w)(t_w)}{(b_f)(t_f) + (b_w)(t_w)}$
5 J-Stiffened	$FCC = \frac{(3)(FC_{ff})(b_f)(t_f) + (FC_{ww})(b_w)(t_w)}{(3)(b_f)(t_f) + (b_w)(t_w)}$
6 Straight Y-Stiffened	$FCC = \frac{(FC_{hh})(b_h)(t_h) + (2)(FC_{ww})(b_w)(t_w) + (2)(FC_{fw})(b_f)(t_w)}{(b_h)(t_h) + (2)(b_w)(t_w) + (2)(b_f)(t_w)}$
7&8 Straight and Curved Y-T Stiffened	$FCC = \frac{(2)(FC_{ff})(b_f)(t_f) + (FC_{hh})(b_h)(t_h) + (2)(FC_{ww})(b_w)(t_w) + (2)(FC_{fw})(b_f)(t_w)}{(2)(b_f)(t_f) + (b_h)(t_h) + (2)(b_w)(t_w) + (2)(b_f)(t_w)}$
9 Trapezoidal Corrugation Semisandwich	$FCC = \frac{(2)(FC_{fc})(b_f)(t_c) + (2)(FC_{dc})(b_d)(t_c)}{(2)(b_f)(t_c) + (2)(b_d)(t_c)}$

TABLE 4.26-3. - PANEL CRIPPLING STRESS RELATIONS - Concluded

Panel Configuration		
10	Truss Core Semisandwich	$FCC = \frac{(2)(FC_{dc})(b_d)(t_c)}{(2)(b_d)(t_c)} = FC_{dc}$
11	Semitrapezoidal Corrugation Semisandwich	$FCC = \frac{(FC_{fc})(b_f)(t_c) + (2)(FC_{dc})(b_d)(t_c)}{(b_f)(t_c) + (2)(b_d)(t_c)}$
12	Hat Section Stiffened	$FCC = \frac{(FC_{zfw})(b_z - b_f)(t_w) + (2)(FC_{ww})(b_w)(t_w) + (2)(FC_{ff})(b_f)(t_f)}{(b_z - b_f)(t_w) + (2)(b_w)(t_w) + (2)(b_f)(t_f)}$
13	Trapezoidal Corrugation	$FCC = \frac{(2)(FC_{fc})(b_f)(t_c) + (2)(FC_{dc})(b_d)(t_c)}{(2)(b_f)(t_c) + (2)(b_d)(t_c)}$
14	Truss Core Corrugation	$FCC = \frac{(2)(FC_{dc})(b_d)(t_c)}{(2)(b_d)(t_c)} = FC_{dc}$
15	Semicircle Corrugation Semisandwich	$FCC = \frac{(FC_{Rt})(\pi)(R)(t_c)}{\pi R t_c} = FC_{Rt}$

4-306

ORIGINAL PAGE IS
OF POOR QUALITY

TABLE 4.26-4. - BUCKLING COEFFICIENT FOR
INFINITE PLATES IN SHEAR

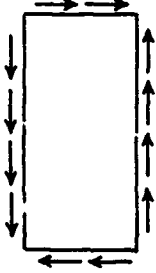
Loading	Edge Support	Coefficient
<p style="text-align: center;">Shear</p> 	<p style="text-align: center;">Simple support on all edges</p> <p style="text-align: center;">Clamped on all edges</p>	<p style="text-align: center;">$K_s = 5.35^*$</p> <p style="text-align: center;">$K_s = 8.98^\dagger$</p>

*National Advisory Committee on Aeronautics, Technical Note 1222.

†National Advisory Committee on Aeronautics, Technical Note 1223.

TABLE 4.26-5. - PARAMETERS FOR SHEAR BUCKLING

Panel Configuration	Shear Buckling Parameters
1 Integral Stiffened	FS for b_s, t_s If $a/b_s > 5.0$, use $K_s = 5.35$ If $a/b_s \leq 5.0$, use curve B, fig. 4.26-8
2 Z-Stiffened	FS for b_s, t_s If $a/b_s > 5.0$, use $K_s = 5.35$ If $a/b_s \leq 5.0$, use curve B, fig. 4.26-8
3 Integral Z-Stiffened	FS for b_s, t_s If $a/b_s > 5.0$, use $K_s = 5.35$ If $a/b_s \leq 5.0$, use curve B, fig. 4.26-8
4 Integral T-Stiffened	FS for b_s, t_s If $a/b_s > 5.0$, use $K_s = 5.35$ If $a/b_s \leq 5.0$, use curve B, fig. 4.26-8
5 J-Stiffened	FS for b_s, t_s If $a/b_s > 5.0$, use $K_s = 5.35$ If $a/b_s \leq 5.0$, use curve B, fig. 4.26-8
6 Straight Y-Stiffened	FS for b_z, t_s If $a/b_z > 5.0$, use $K_s = 5.35$ If $a/b_z \leq 5.0$, use curve B, fig. 4.26-8 FS for b_s, t_s If $a/b_s > 5.0$, use $K_s = 5.35$ If $a/b_s \leq 5.0$, use curve B, fig. 4.26-8
7&8 Straight and Curved Y-T Stiffened	FS for b_z, t_s If $a/b_z > 5.0$, use $K_s = 5.35$ If $a/b_z \leq 5.0$, use curve B, fig. 4.26-8 FS for b_s, t_s If $a/b_s > 5.0$, use $K_s = 5.35$ If $a/b_s \leq 5.0$, use curve B, fig. 4.26-8

TABLE 4.26-5. - PARAMETERS FOR SHEAR BUCKLING - Concluded

Panel Configuration	Shear Buckling Parameters
<p>9</p> <p>Trapezoidal Corrugation Semisandwich</p>	<p>FS for $(b_s - b_f), t_s$ If $a/(b_s - b_f) > 5.0$, use $K_s = 5.35$ If $a/(b_s - b_f) \leq 5.0$, use curve B, fig. 4.26-8</p>
<p>10</p> <p>Truss Core Semisandwich</p>	<p>FS for b_s, t_s If $a/b_s > 5.0$, use $K_s = 5.35$ If $a/b_s \leq 5.0$, use curve B, fig. 4.26-8</p>
<p>11</p> <p>Semitrapezoidal Corrugation Semisandwich</p>	<p>FS for b_s, t_s If $a/b_s > 5.0$, use $K_s = 5.35$ If $a/b_s \leq 5.0$, use curve B, fig. 4.26-8</p>
<p>12</p> <p>Hat Section Stiffened</p>	<p>FS for b_z, t_s If $a/b_z > 5.0$, use $K_s = 5.35$ If $a/b_z \leq 5.0$, use curve B, fig. 4.26-8 FS for b_s, t_s If $a/b_s > 5.0$, use $K_s = 5.35$ If $a/b_s \leq 5.0$, use curve B, fig. 4.26-8</p>
<p>13</p> <p>Trapezoidal Corrugation</p>	<p>FS for b_d, t_c If $a/b_d > 5.0$, use $K_s = 5.35$ If $a/b_d \leq 5.0$, use curve B, fig. 4.26-8 FS for b_f, t_c If $a/b_f > 5.0$, use $K_s = 5.35$ If $a/b_f \leq 5.0$, use curve B, fig. 4.26-8</p>
<p>14</p> <p>Truss Core Corrugation</p>	<p>FS for b_d, t_c If $a/b_d > 5.0$, use $K_s = 5.35$ If $a/b_d \leq 5.0$, use curve B, fig. 4.26-8</p>
<p>15</p> <p>Semicircle Corrugation Semisandwich</p>	<p>FS for b_s, t_s If $a/b_s > 5.0$, use $K_s = 5.35$ If $a/b_s \leq 5.0$, use curve B, fig. 4.26-8</p>

TABLE 4.26-6. — PARAMETERS FOR PANEL SECTION PROPERTIES

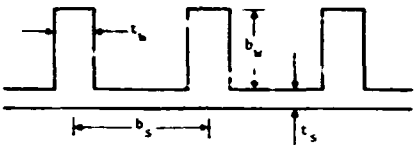
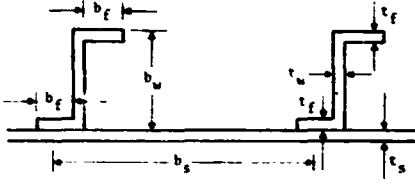
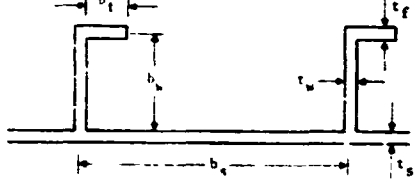
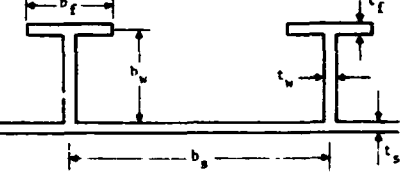
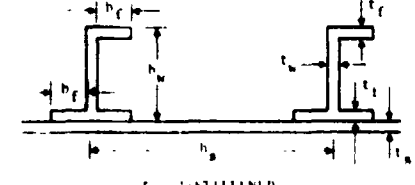
Panel Configuration	Auxiliary Relations	Dimensionless Geometric Expressions
 <p>1. INTEGRALLY STIFFENED</p>	$r_{bz} = 0$ $r_{bw} = \frac{b_w}{b_s}$ $r_{tw} = \frac{t_w}{t_s}$	$\alpha = 1 + r_{bw} r_{tw}$ $\beta = 0.5 r_{bw}^2 r_{tw}$ $\gamma = 0.333 r_{bw}^3 r_{tw}$
 <p>2. 2-STIFFENED</p>	$r_{bw} = \frac{b_w}{b_s}$ $r_{tw} = \frac{t_w}{t_s}$ $r_{bz} = 0$	$\alpha = 1 + 1.6 r_{bw} r_{tw}$ $\beta = 0.8 r_{bw}^2 r_{tw}$ $\gamma = 0.633 r_{bw}^3 r_{tw}$
 <p>3. INTEGRAL 2</p>	$r_{bw} = \frac{b_w}{b_s}$ $r_{tw} = \frac{t_w}{t_s}$ $r_{bz} = 0$	$\alpha = 1 + 1.3 r_{bw} r_{tw}$ $\beta = 0.8 r_{bw}^2 r_{tw}$ $\gamma = 0.633 r_{bw}^3 r_{tw}$
 <p>4. INTEGRAL 1</p>	$r_{bw} = \frac{b_w}{b_s}$ $r_{tw} = \frac{t_w}{t_s}$ $r_{bz} = 0$	$\alpha = 1 + 1.6 r_{bw} r_{tw}$ $\beta = 1.1 r_{bw}^2 r_{tw}$ $\gamma = 0.933 r_{bw}^3 r_{tw}$
 <p>5. 1-STIFFENED</p>	$r_{bw} = \frac{b_w}{b_s}$ $r_{tw} = \frac{t_w}{t_s}$ $r_{bz} = 0$	$\alpha = 1 + 1.9 r_{bw} r_{tw}$ $\beta = 0.8 r_{bw}^2 r_{tw}$ $\gamma = 0.633 r_{bw}^3 r_{tw}$

ORIGINAL PAGE IS
OF POOR QUALITY

TABLE 4.26-6. — PARAMETERS FOR PANEL SECTION PROPERTIES — (Continued)



Panel Configuration	Auxiliary Relations	Dimensionless Geometric Expressions
 <p>6. STRAIGHT Y-STIFFENED</p>	$r_{bw} = \frac{b_w}{b_s}$ $r_{tw} = \frac{t_w}{t_s}$ $r_{bz} = 1.04 r_{bw}$	$\alpha = 1 + r_{bz} + 3.06 r_{bw} r_{tw}$ $\beta = 1.23 r_{bw}^2 r_{tw}$ $\gamma = 0.865 r_{bw}^3 r_{tw}$
 <p>7. STRAIGHT Y-T STIFFENED</p>	$r_{bw} = \frac{b_w}{b_s}$ $r_{tw} = \frac{t_w}{t_s}$ $r_{bz} = 1.04 r_{bw}$	$\alpha = 1 + r_{bz} + 5.17 r_{bw} r_{tw}$ $\beta = 4.83 r_{bw}^2 r_{tw}$ $\gamma = 7.07 r_{bw}^3 r_{tw}$
 <p>8. CURVED Y-T STIFFENED</p>	$r_{bw} = \frac{b_w}{b_s}$ $r_{tw} = \frac{t_w}{t_s}$ $r_{bz} = 1.04 r_{bw}$	$\alpha = 1 + r_{bz} + 5.13 r_{bw} r_{tw}$ $\beta = 5.13 r_{bw}^2 r_{tw}$ $\gamma = 7.58 r_{bw}^3 r_{tw}$
 <p>9. TRAPEZOIDAL CORRUGATION SEMISANDWICH</p>	$r_{bd} = \frac{b_d}{b_s}$ $r_{tc} = \frac{t_c}{t_s}$ $m = \frac{1}{2r_{bd}} - \cos \phi$	$\alpha = 1 + \frac{m + 1}{K_1^{1/2} (m + \cos \phi)^2}$ $\beta = \frac{(m + 1) \sin \phi}{4K_1^{1/2} (m + \cos \phi)^3}$
 <p>10. TRUSS CORE SEMISANDWICH</p>	$r_{bz} = 0$ $K_1^{1/2} = \frac{2r_{bd}}{r_{tc}}$	$\gamma = \frac{(m + 0.667) \sin^2 \phi}{8K_1^{1/2} (m + \cos \phi)^4}$

TABLE 4.26-6. - PARAMETERS FOR PANEL SECTION PROPERTIES - (Continued)

Panel Configuration	Auxiliary Relations	Dimensionless Geometric Expressions
 <p>11. SEMIRAPETOIDAL CORRUGATION SEMISANDWICH</p>	$r_{bd} = \frac{b_d}{b_s}$ $r_{tc} = \frac{t_c}{t_s}$ $m = \frac{1}{2r_{bd}} - \cos \phi$ $r_{bz} = 0$ $K_1^{1/2} = \frac{2r_{bd}}{r_{tc}}$	$\alpha = 1 \cdot \left(\frac{2(m+2)}{K_1^{1/2}(m+2\cos\phi)^2} \right)$ $\beta = \frac{r_{tc}(m+1)\sin\phi}{K_1^{1/2}(m+2\cos\phi)^3}$ $\gamma = \frac{2(m+0.667)\sin^2\phi}{K_1^{1/2}(m+2\cos\phi)^4}$
 <p>12. HAT SECTION STIFFENED</p>	$r_{bf} = \frac{b_f}{b_w} r_{bw}$ $r_{tw} = \frac{2(1-r_{bf})}{K_1^{1/2}}$ $r_{bw} = \frac{b_w}{b_s}$ $r_{bz} = 1.0$	$\alpha = 2 + r_{tw}(1 + 2r_{bw} \cdot r_{bf})$ $\beta = r_{bw} r_{tw}(1 - r_{bf} \cdot r_{bw})$ $\gamma = r_{bw}^2 r_{tw}(1 - r_{bf} \cdot 0.67 r_{bw})$
 <p>13. TRAPEZOIDAL CORRUGATION</p>	$r_{bd} = \frac{b_d}{b_s}$ $m = \frac{1}{2r_{bd}} - \cos \phi$	$\alpha = 2r_{bd}(m+1)$ $\beta = r_{bd}^2(m+1)\sin\phi$
 <p>14. TRUSS CORE CORRUGATION</p>	$r_{bz} = 0$	$\gamma = r_{bd}^3(m+0.667)\sin^2\phi$

ORIGINAL PAGE IS
OF POOR QUALITY

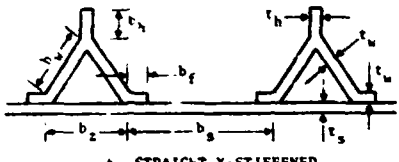
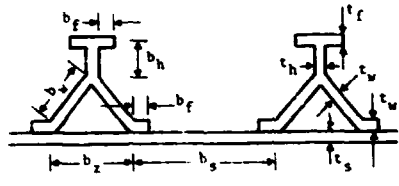
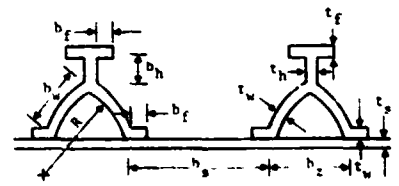
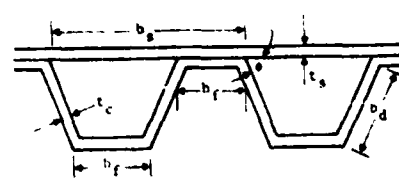
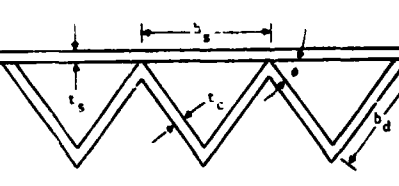
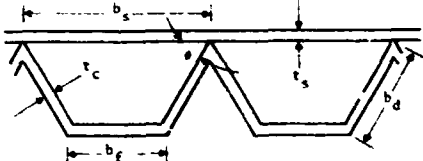
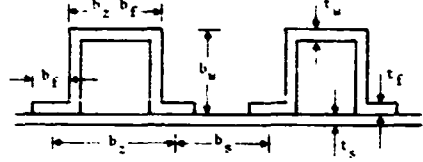
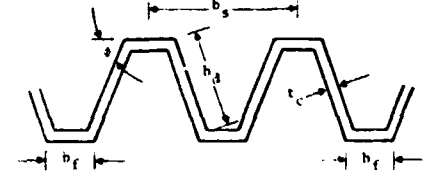
TABLE 4.26-6. - PARAMETERS FOR PANEL SECTION PROPERTIES - (Concluded)

Panel Configuration	Auxiliary Relations	Dimensionless Geometric Expressions
 <p>15. SEMICIRCLE CORRUGATION SANDWICH</p>	$r_{tc} = \frac{t_c}{t_s}$ $\bar{t} = t_s \left(1 + \frac{\pi R}{b_s} r_{tc} \right)$	$\alpha = 1 + 1.57 r_{tc}$ $B = 0.5 r_{tc}$ $\gamma = 0.196 r_{tc}$

TABLE 4.26-7. - COLUMN FIXITY COEFFICIENTS



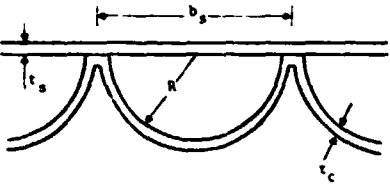

Column Fixed Type	Column End Fixity Coefficient
<p>Both ends pinned.</p> 	<p>$C = 1.0$</p>
<p>Both ends fixed.</p> 	<p>$C = 4.0$</p>
<p>One end pinned. One end fixed.</p> 	<p>$C = 2.25$</p>
<p>One end free. One end fixed.</p> 	<p>$C = 0.25$</p>
<p>Both ends between fixed and pinned.</p> 	<p>$C = 1.78$</p>

TABLE 4.26-8. - INTERACTION EQUATIONS

Interaction Formula	Shear	Axial	Biaxial	Torsion	Bending	Transverse Shear	Normal Pressure
$R_c + R_{tor}^2 = 1$		X		X			
$R_b^{1.5} + R_{tor}^2 = 1$				X	X		
$R_c + R_b + R_{tor}^2 = 1$		X		X	X		
$R_b + R_s^2 = 1$					X	X	
$R_c^2 + R_p = 1$		X					X
$R_x + R_y = 1$			X				
$R_c + R_s^2 = 1$		X				X	
$R_s^2 + R_b^2 = 1$	X				X		
$R_c^2 + R_s^2 = 1$ (Inelastic)	X	X					

4.27 RANDOM VIBRATION ANALYSIS

The requirement to provide this support in ISAS Phase B was deleted by the Structures Branch (ES2). Figure 4.27-1 is a data flow diagram of the Random Vibration Analysis.

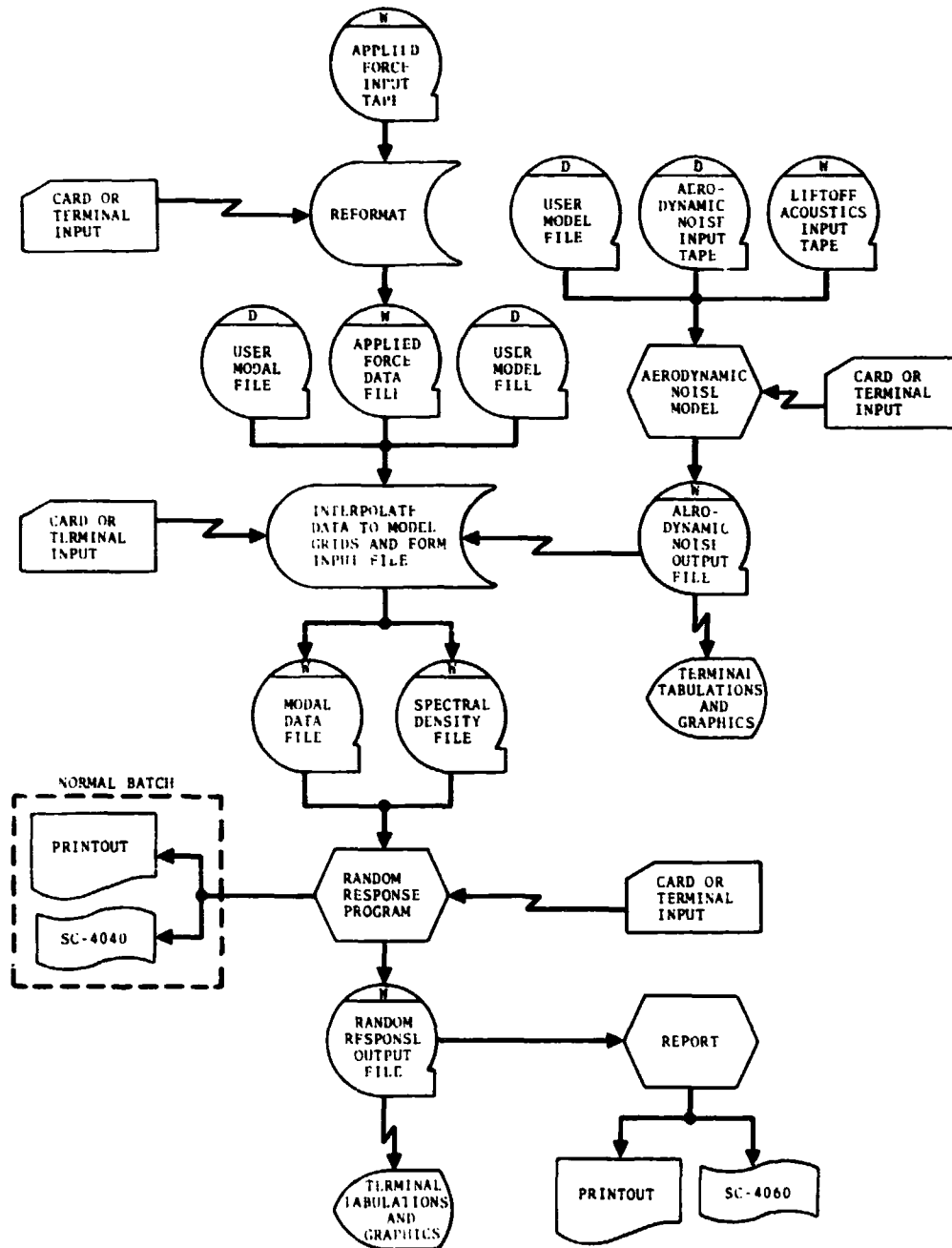

Figure 4.27-1. - Data flow diagram for Random Vibration Analysis.

4.28 STATIC AEROELASTICITY

4.28.1 PURPOSE

This function will allow the user, operating in the demand mode, to prepare an input file for the Static Aeroelasticity Program, to display data on the remote console screen, to calculate flexible-to-rigid factors, and to produce an Aeroelasticity Data Base. Flexible-to-rigid factors will be calculated by the Static Aeroelasticity Correction Program (STAC). STAC will be a demand program and will generate the Aeroelasticity Data Base as a final product of the function. This file will contain force coefficient data adjusted for the effects of structural flexibility. Figure 4.28-1 is a data flow diagram of the Static Aeroelasticity function.

4.28.2 INPUT

Input for this function will be contained in two data files. These are:

- Structural Influence Coefficients File
- Aerodynamic Influence Coefficients File

During the course of processing, three additional files will be created and used by succeeding steps in the function. These are:

- Static Aeroelasticity Input File
- Static Aeroelasticity Output File
- Static Aeroelasticity Force Coefficient Data File

Formats for all files used in this function can be found in the appendix.

The user will be required to enter some data directly at the terminal. These will include such items as file identification and flight conditions.

4.28.3 PROCESSING

Upon entering the function, the user should type in two file ID's and a set of retrieval parameters (Mach number, angle of attack (α), angle of sideslip (β), elevon deflection (Δe), rudder deflection (Δr), etc.). One file ID will specify a Structural Influence Coefficients File. This file will be created in the NASTRAN OUTPUT2 module and will contain the structural grid geometry (X, Y, Z) and the structural influence coefficient matrix [S].

The second file ID will represent the Aerodynamic Influence Coefficients File produced by the ACE function. This file will be accessed to retrieve aerodynamic panel geometry (X, Y, Z), control points, aerodynamic panel areas [B], rigid pressure coefficients (ΔC_p)_R, and the aerodynamic influence coefficient matrix [A] and will be indexed by the retrieval parameters. If the file does not contain data at the required retrieval parameters, the ISAS Flight Conditions Interpolation Routine (described in the Phase A detailed requirements document) will be used to obtain interpolated data at the required retrieval parameter values.

The grid locations relating to geometry in these two files will not correspond. The ISAS Spline Interpolation Procedure, described in the Phase A detailed requirements document, will be used to interpolate the structural influence coefficient matrix and obtain values at the aerodynamic panel geometry locations. This interpolated influence coefficient matrix will be stored along with the aerodynamic panel geometry in an Interpolated Structural Data File. At this point, the user may choose to have the aerodynamic panel geometry data (X, Y, Z) displayed on the

screen in tabular form. The structural slopes can be tabulated or plotted versus the location variable (X for fuselage, Y for wing, and Z for tail) at each user-specified value and tolerance. Figures 4.28-2 and 4.28-3 are examples of the data to be tabulated. The user will specify the values of the location variable and a tolerance for which the slopes are to be plotted. Figure 4.28-4 is an example of a plot.

The next step in the process will be to form a Static Aeroelasticity Input File. From the console, the user will input the title/ID header information, dynamic pressure, wing root Y-coordinate, and vertical tail root Z-coordinate. These data and the grid geometry (X, Y, Z), rigid pressure coefficients $(\Delta C_p)_R$, aerodynamic influence coefficient matrix [A], and aerodynamic panel areas [B] retrieved earlier from the Aerodynamic Influence Coefficients File for the given retrieval parameters should be combined with the interpolated structural influence coefficient matrix to form the input file. This file will be used as input to the Static Aeroelasticity Program (STAP). A description of STAP can be found in the batch program documentation and is not presented here.

STAP will output a Static Aeroelasticity Output File. Data from this file can be displayed and checked at the terminal. The display should include the title/ID header, flight conditions (M, α), total rigid aerodynamic panel load (F_R), total aerodynamic panel load due to flexibility (F_f), wing root moment (\bar{M}_W), vertical tail root moment (\bar{M}_T), flexible-to-rigid load ratio, and divergence dynamic pressure (q_D). The following variables can be either tabulated versus aerodynamic panel control point or plotted versus the X-dimension structural point coordinates: aerodynamic panel area [B], rigid pressure coefficients $(\Delta C_p)_R$, structural slope (θ), pressure coefficients due to flexibility $(\Delta C_p)_f$, flexible-to-rigid pressure ratio, rigid aerodynamic panel load $(\Delta F)_R$, aerodynamic panel load due to flexibility $(\Delta F)_f$, and flexible-to-rigid loading ratio. Figure 4.28-5

shows a sample tabular printout, and figures 4.28-6, 4.28-7, and 4.28-8 are examples of the type of plots that will be available to the user.

The processing starting after the creation of the Static Aeroelasticity Output File and through the creation of the Static Aeroelasticity Force Coefficient Data File (see the function flow chart, fig. 4.28-1) is the same as in the ISAS Aerodynamic Loads function, section 4.3. The Static Aeroelasticity Output File will replace the Interim Aerodynamic Data File as the input source, and the output will be stored in the Static Aeroelasticity Force Coefficient Data File rather than the Force Coefficient Data File. The format of the Static Aeroelasticity Output File will correspond to the format required by the Aerodynamic Loads function.

The Static Aeroelasticity Force Coefficient Data File will have the same format as the Force Coefficient Data File, but it should contain data for wing and vertical tail only. These two files should be used for input to the Static Aeroelasticity Correction Program (STAC). STAC should be a demand program that adjusts the wing and vertical tail aeroelasticity force coefficient data for the effects of structural flexibility. It should search the Force Coefficient Data File and retrieve data for the appropriate flight conditions, using the ISAS Flight Conditions Interpolation Routine, if necessary. For each wing and vertical tail point, STAC should add the static aeroelasticity force coefficient value to the appropriate rigid value. A flexible-to-rigid factor should also be calculated for each data point, where

$$\text{FACTOR} = 1 + (\text{FORCE})_{\text{FLEX}} / (\text{FORCE})_{\text{RIGID}}$$

$(\text{FORCE})_{\text{FLEX}}$ will be the value from the Static Aeroelasticity Force Coefficient Data File, and $(\text{FORCE})_{\text{RIGID}}$ will be the corresponding value from the Force Coefficient Data File.

The Aeroelasticity Data Base will be created by STAC. It will contain the force coefficient data with the corrected wing and vertical tail points and the flexible-to-rigid factors for those points. Terminal tabulations and graphics requirements for the Aeroelasticity Data Base are the same as those detailed for the Aerodynamic Data Base Generator, section 4.2.

4.28.4 OUTPUT

Output for this function will consist of files and graphical displays at the remote terminal. The graphical displays will be tabulations and plots of various data contained in files or calculated by the function. The specific displays available are described in the processing section.

The files output by this function will be:

- Interpolated Structural Data File
- Static Aeroelasticity Output File
- Aeroelasticity Data Base
- Static Aeroelasticity Force Coefficient Data File

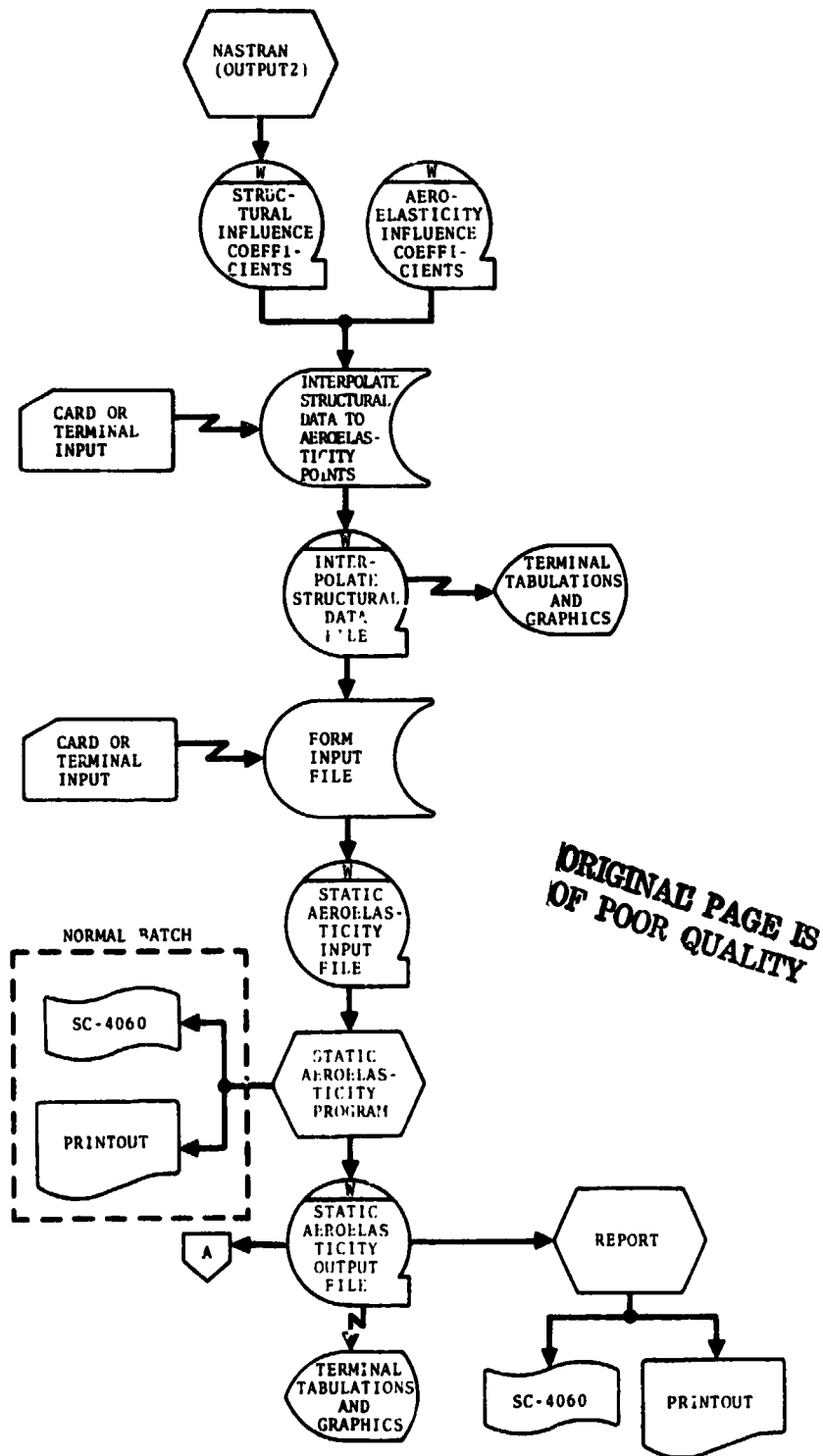

**ORIGINAL PAGE IS
OF POOR QUALITY**

Figure 4.28-1. - Data flow diagram for Static Aeroelasticity.

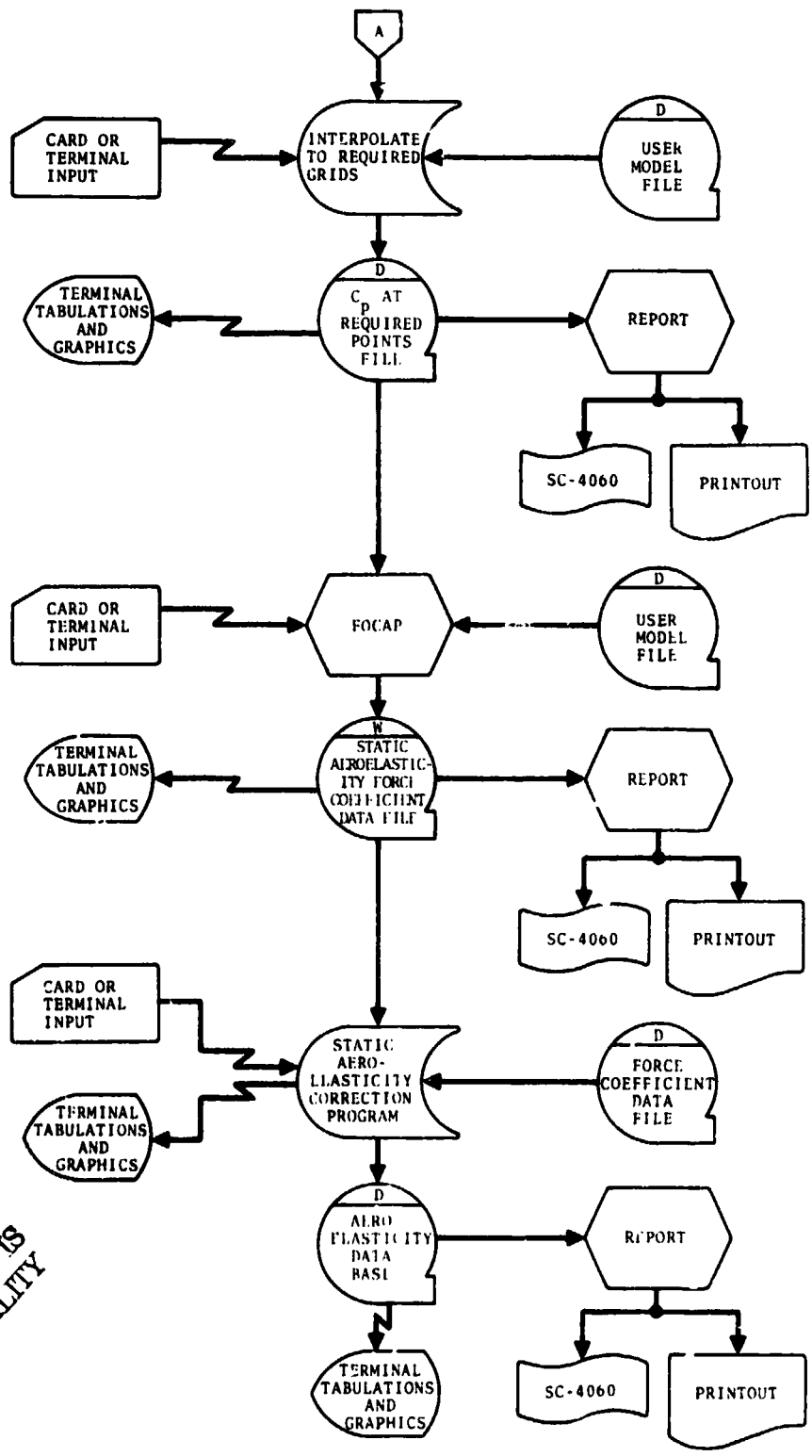

ORIGINAL PAGE IS
OF POOR QUALITY

Figure 4.28-1. - Data flow diagram for Static Aeroelasticity (concluded).

AERODYNAMIC PANEL GEOMETRY

ID	COORDINATES		
	X	Y	Z
1	.99750	1.42000	.00000
2	2.99750	1.42000	.00000
.	.	.	.
.	.	.	.
.	.	.	.
24	7.00000	9.60000	.00000
25	9.00000	9.60000	.00000

Figure 4.28-2. - Example of geometry data tabulation.

ORIGINAL PAGE IS
OF POOR QUALITY

PANEL ID'S	COLUMN(1)	COLUMN(2)	COLUMN(3)	COLUMN(4)	COLUMN(5)	COLUMN(6)	COLUMN(7)	COLUMN(8)	COLUMN(9)	COLUMN(10)
ROW(1)	-4.73000-04	-1.70000-05	2.00000-06	0.00000	0.00000	-4.08000-04	-1.20000-05	1.70000-05	1.20000-05	0.00000
ROW(2)	-7.20000-05	-6.10000-05	0.00000	0.00000	0.00000	-1.61000-04	-4.10000-05	0.00000	0.00000	0.00000
⋮	⋮	⋮	⋮	⋮	⋮	⋮	⋮	⋮	⋮	⋮
ROW(24)	-1.20000-05	-8.00000-06	3.00000-06	8.70000-05	2.43000-04	-8.40000-05	-7.00000-05	3.60000-05	5.87000-04	1.33200-03
ROW(25)	-1.10000-06	-5.00000-06	0.00000	1.02000-04	3.17000-04	-6.00000-05	-6.40000-05	3.00000-06	5.69000-04	1.65000-03
	COLUMN(11)	COLUMN(12)	COLUMN(13)	COLUMN(14)	COLUMN(15)	COLUMN(16)	COLUMN(17)	COLUMN(18)	COLUMN(19)	COLUMN(20)
ROW(1)	-2.30000-04	-2.00000-05	1.20000-05	2.00000-05	0.00000	-1.43000-04	0.00000	1.20000-05	1.60000-05	2.90000-05
ROW(2)	-9.50000-05	-5.00000-06	3.00000-06	3.00000-06	0.00000	-1.23000-04	0.00000	5.00000-06	1.30000-05	0.00000
⋮	⋮	⋮	⋮	⋮	⋮	⋮	⋮	⋮	⋮	⋮
ROW(24)	-1.83000-04	-1.33000-04	6.60000-05	1.28500-03	3.13800-03	-2.24000-04	-1.76000-04	3.80000-05	1.88300-03	4.53500-03
ROW(25)	-1.26000-04	-1.17000-04	1.20000-05	1.09100-03	3.86100-03	-1.87000-04	-1.47000-04	0.00000	1.34700-03	5.67900-03

4-325

Figure 4.28-3. - Example of matrix of structure slopes.

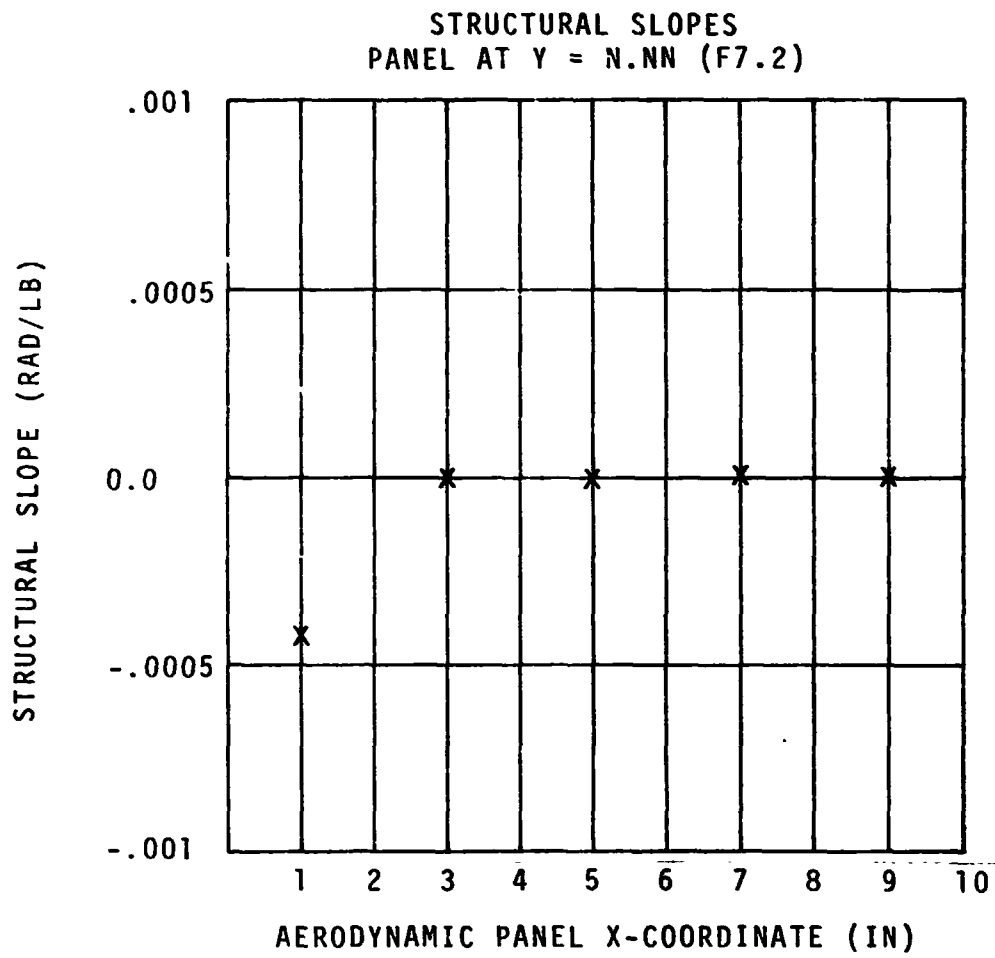

Figure 4.28-4. - Example plot of structural slopes versus chord at each span station.

STATIC AEROELASTICITY OUTPUT

(FILE 'D HEADER)

MACH NUMBER = 2.00
 RIGID AERO PANEL LOAD = 2.74284+01 LB
 WING ROOT MOMENT = 1.14142+02 IN-LB
 FLEX-TO-RIGID LOAD RATIO = 9.53515-01
 ANGLE OF ATTACK = 400 DEG
 AERO PANEL LOAD (FLEX) = 1.27502+00 LB
 VERTICAL TAIL ROOT MOMENT = 0.0000 IN-LB
 DIVERGENCE DYNAMIC PRESSURE = 12.6625 LB/IN**2

PANEL ID	PANEL COORDINATES			AERO PANEL AREA	RIGID PRES COEFF
	X	Y	Z		
1	.99750	1.42000	.00000	2.90	.161227
2	2.99750	1.42000	.50000	5.82	.161227
.
.
24	7.00000	9.60000	.00000	.08000	.039879
25	9.00000	9.60000	.00000	.08000	.034427

PANEL ID	STRL SLOPE (RAD)	PRES COEFF DUE TO FLEXIBILITY	FLEX-TO-RIGID PRESSURE RATIO	RIGID AERO PANEL LOAD(LB)	AERO PANEL LOAD DUE TO FLEX(LB)	FLEX-TO-RIGID LOADING RATIO
1	-.741960-04	-.171348-03	.998937+00	.104169+01	-.110708-02	.998937+00
2	.101090-02	.238912-02	.101482+01	.203372+01	.301371-01	.101482+01
.
.
24	-.979914-02	-.100835-01	.747147+00	.691233-02	-.174781-02	.+00
25	-.110787-01	-.872662-02	.746515+00	.596727-02	-.151261-02	.+00

Figure 4.28-5. - Static Aeroelasticity Output File tabulation.

ORIGINAL PAGE IS
 OF POOR QUALITY

AERODYNAMIC PANEL COORDINATES

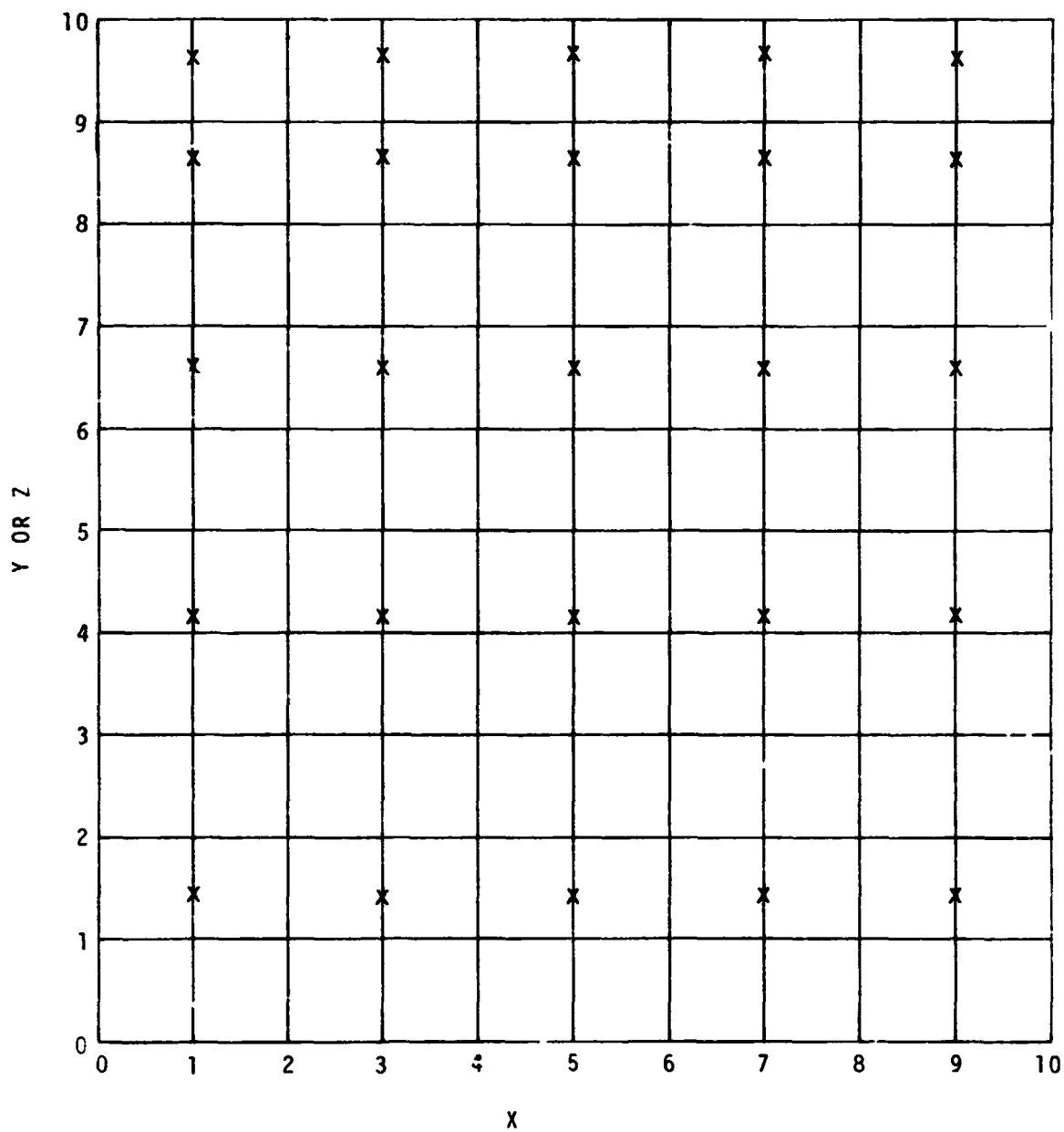

Figure 4.28-6. - Example of plot of aerodynamic panel coordinates.



STRUCTURAL SLOPE

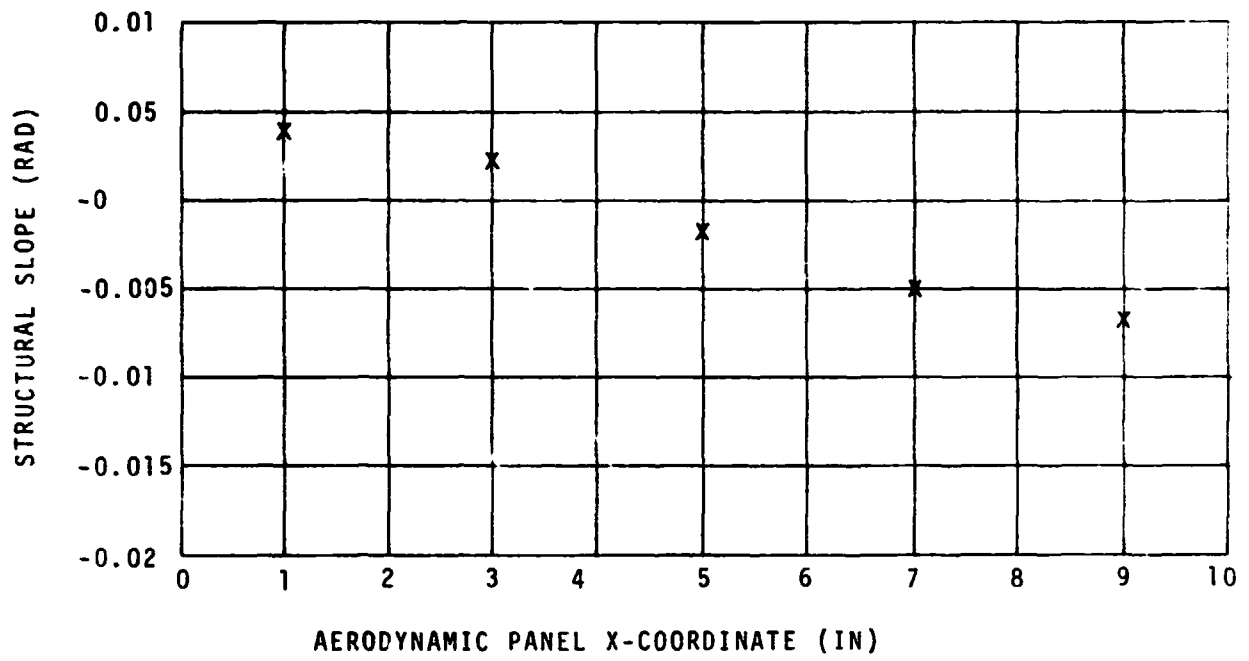

Figure 4.28-7. - Example of plot of structural slope.

RIGID PRESSURE COEFFICIENTS

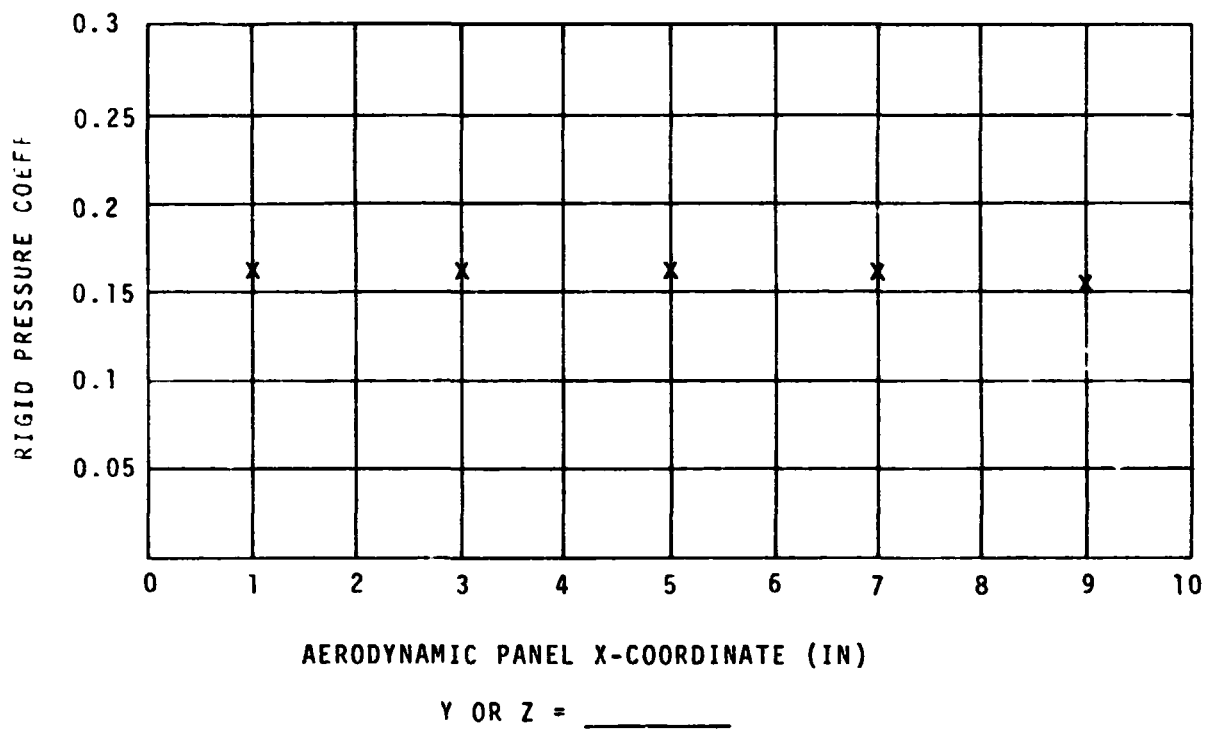
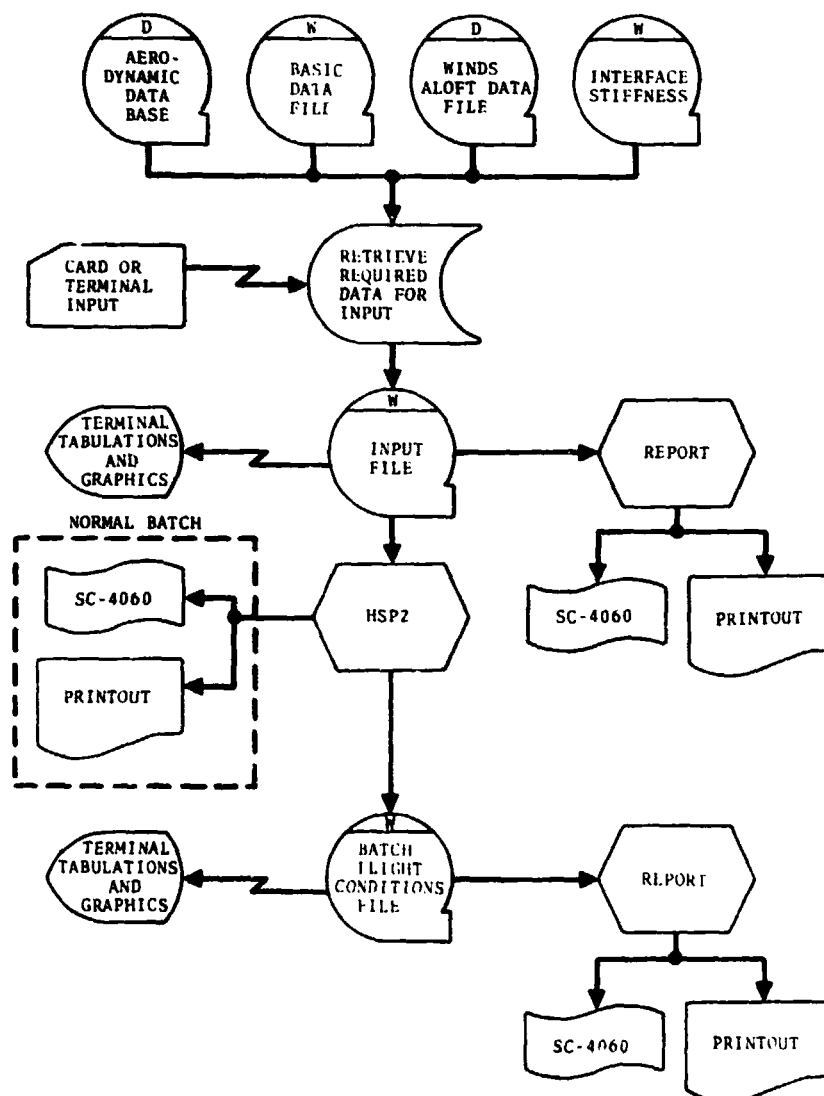

Figure 4.28-8. — Example of plot of rigid pressure coefficients.

4.29 TWO-BODY SEPARATION

The requirement to provide support in this area was deleted by the Structures Branch (ES2). See figure 4.29-1 for a data flow diagram of the Two-Body Separation function.



Figur. 4.29-1. - Data flow diagram for Two-Body Separation.

4.30 THREE-BODY SEPARATION

The requirement to provide support in this area was deleted by the Structures Branch (ES2). Figure 4.30-1 is a data flow diagram of the Three-Body Separation function.

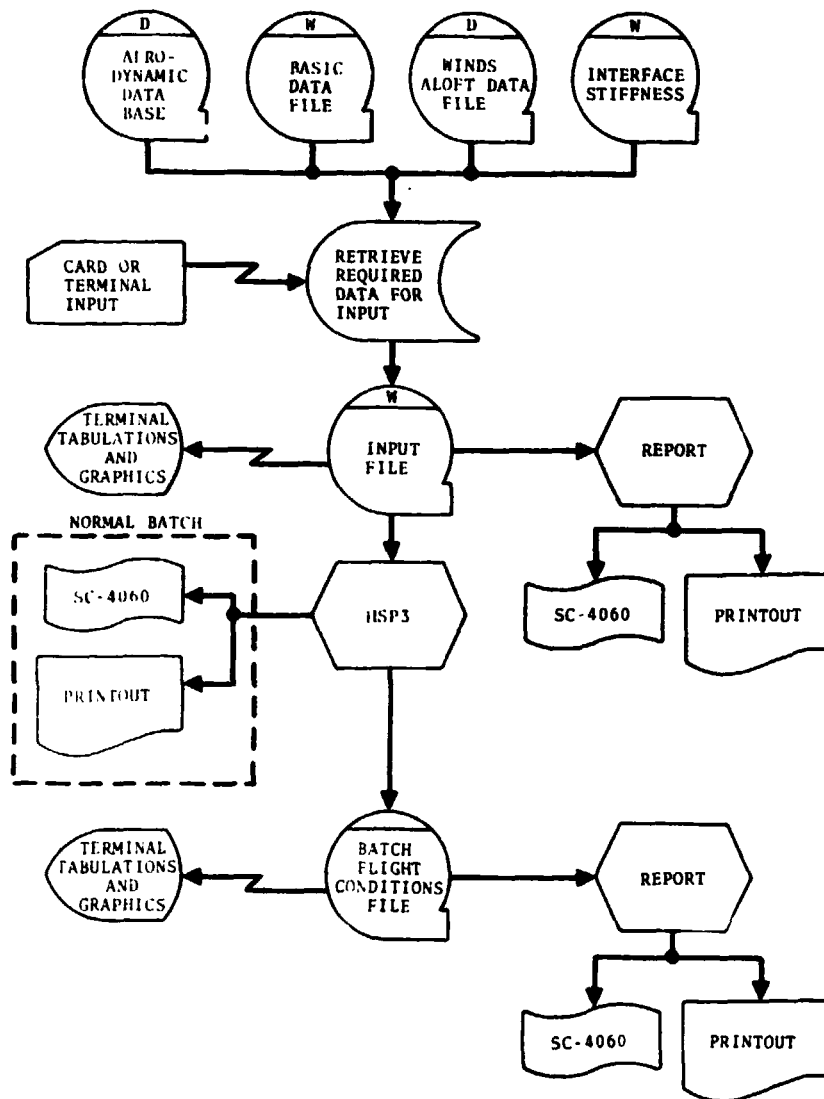

Figure 4.30-1. - Data flow diagram of Three-Body Separation.

ORIGINAL PAGE IS
OF POOR QUALITY

4.31 USER MODEL FILE GENERATOR

4.31.1 PURPOSE

The User Model File Generator function will produce a model definition oriented toward aerodynamic or structural modeling, depending on the phase of the application. Figure 4.31-1 is a data flow diagram of the User Model File Generator function. For the structural model, grid points will be defined, and structural elements will be described as functions of the grid points. For the aerodynamic model, cutting planes or traces will be defined along the model, and coordinates and slopes of grid points will be defined around these traces. An interactive graphics display will be used to assist in the creation of the User Model File by permitting the creator to visually inspect and modify the model at all stages of its development.

4.31.2 INPUT

The input will consist of the Basic Geometry Data File, a previously created User Model File (optional), NASTRAN card files (optional), and interactive terminal entries as required to develop and verify the model definition as the User Model File is generated. The Basic Geometry Data File and the User Model File are defined in the appendix. The terminal input can be either keyboard or display selectable.

The keyboard will be used for:

- Entry of substructure and region identification numbers; X, Y, Z coordinate values; angles of rotation; direction cosines; and other data as needed to define model components as visual aids in the model definition
- Editing of tabular displays of User Model Files

Display selectable input will include:

- Menu selection and paging (forward and backward)
- Submenu item selection
- Indication of cutting plane position
- Grid point positioning
- Grid point selection for element definition
- Structural element type selection
- Cell selection and definition
- Airfoil definition

4.31.3 PROCESSING

The processing function will consist of two major categories, each of which will be composed of a number of subprocesses.

The model generation will include:

- Selection and graphical display of the surface
- Symmetry definition
- Cutting plane specification
- Grid generation
- Element definition (structural, airfoil, cell)

The Data edit phase will include:

- Tabular and graphical display
- Editing
- Merging
- Resequencing by batch program

An interactive graphics terminal will be used in the processing function of this program. This program will contain capabilities which will be inherent to interactive graphics terminal usage. These capabilities will include:

- Display of control points
- Display of lines connecting the control points
- Creation, deletion, and modification of grid points (coordinates and slopes)
- Creation, deletion, and modification of structural elements or aerodynamic airfoil elements
- Means to loop back through the program
- Dialogue in the form of questions and suggestions initiated by the program
- Interpretation of user response to dialogue
- Ability to break (or terminate) the program at any stage and restart it at a later time.

This program will also include less sophisticated capabilities such as tabular display and edit. The dialogue will be such that sequential processing can be accomplished readily when a minimum of interaction is needed. The capability to remove hidden lines will not be included.

4.31.3.1 Model Generation

The first step in the processing function will be the dynamic assignments of the needed files. The User Model File to be created must always be identified. The other files which need to be assigned will depend on the source of the data to be used in the model generation. The user will be able to start with no input files and create the model from scratch using the various input devices to input the data. Alternately, the

user will be able to start with a Basic Geometry Data File and a NASTRAN card image file if desired. The user will be asked to identify all needed files.

When the file names have been entered, the terminal user will be asked to identify the type of model application – aerodynamic or structural. Once the model application is chosen, the user/program dialogue will be slanted toward that discipline.

4.31.3.1.1 Structural Model Generation

When the structural option is selected, the user can choose to continue through the mainstream of the program and create, inspect, and refine the grid points and structural elements for the User Model File. Alternately, he can choose to enter or update the cell information of an existing User Model File.

When the structural model generation option is chosen, the user will be given a choice of methods for selecting the structure and substructure of interest from the Basic Geometry Data File. He can elect to enter coordinates describing a rectangular solid to be used for displaying the structure falling within its bounds, or he can choose to select the structure and substructure identifications.

When the identifications (ID's) are to be used to select the structure and substructure, the user will enter these ID's in either of two ways: with a 1 to 15 alphanumeric character ID or a code corresponding to the alphanumeric ID. The user can display a table containing the codes versus the alphanumeric ID's in order to facilitate the structure or substructure selection.

The contents of the Basic Geometry Data File will be searched for the ID's entered. If either ID is not found, a message will

be displayed informing the terminal user of the problem and giving him the option of entering another ID, of defining a rectangular volume to be displayed, of going to the data edit phase, or of terminating the job.

When the structure/substructure selection is to be made by entering coordinates describing a rectangular solid, the user will enter the X, Y, Z coordinates defining the upper and lower bounds of the solid. At this time, three display-selectable menu items (light buttons) will be established to assist with structure selection and viewing. The zoom and alter view options will be provided to permit viewing the displayed structure in an enlarged format and from other viewing angles and a restore button will also be provided to return the display to its original unzoomed, unaltered view. These viewing aids will always be available throughout the model generation process.

When the user has selected a substructure with which he wishes to work, he will indicate he is ready to go to the next menu by selecting the page option. The selected substructure will be displayed in its entirety, and the user will be asked to identify the region with which he wishes to work.

The method of selecting the region will be the same as for the substructure. The user can enter the desired region identification (1 to 15 characters) or the corresponding code. If the ID is not found on the Basic Geometry Data File, the terminal operator will be given the option of reentering the region identification, making a display selection, or returning to the substructure selection menu.

More than one region can be selected for display at one time. Once the region has been selected and the next page option chosen, the display will change to one of selected regions only.

At this point in the processing, the user can define substructures for the User Model File or use the substructure definition from the Basic Geometry Data File. This function should provide the capability to generate grid points for sections of the model in different coordinate systems. These data will be maintained on the User Model File. Also, the function will provide the capability to transform the coordinates to different coordinate systems upon command.

At this time, the terminal operator will be requested to indicate the symmetry status. If symmetry does not exist or if the user wishes to skip its definition, the none option will be selected. However, if the region is symmetrical and this condition is to be used, the symmetry option will be selected. The axis (or axes) of symmetry is then specified, causing flags to be set which will activate the automatic specification of grid points and elements when their symmetrical counter parts are defined.

When the symmetry condition exists, it may be desirable to reduce the number of lines to be displayed at any one time. A symmetric model light button (display selectable option) will be provided for this purpose. When the symmetric model button is chosen and symmetry exists (the symmetry flag has been set), the model will be reduced to the symmetric display. As with the zoom and alter view light buttons, the symmetric model button may be activated at any time. In addition, there will be a light button which will enable the user to restore the complete display.

The next step will involve the creation of cutting planes for visual inspection of the model and for definition of model lines. The positioning of the cutting plane will be under user control, and the method of identifying this plane will be the same as described in the Basic Geometry File Generator function.

Once a cutting plane is established, its position can be altered or deleted by selecting the appropriate light buttons. Display selections will be available which, when used in conjunction with an established cutting plane, will result in the display of the trace from any selected view made by passing the cutting plane through the region.

The next step in the model definition will be the grid point generation. The terminal user will have the option of selecting automatic or manual grid generation. He also must indicate the mesh or number of divisions between control points.

When the grid is to be automatically generated, the user can choose from several regular shells of revolution to generate the desired grid points or he can use the milling machine lofting routine FMILL from the APT system*. If a shell of revolution is selected the user will be prompted for keyboard entries of the necessary dimensions and grid spacing specifications.

When the FMILL option is selected, the grid spacing will be determined by specifying through the keyboard the number of rows and columns in the grid matrix of the segment. The control points used in the FMILL routine of the Basic Geometry File Generator function will define the segmental subdivision of the regions. Additional FMILL input parameters will define the mesh of each segment. Thus, automatic grid point numbering will make use of the FMILL generated mesh. The grid points automatically created can be numbered automatically also or they can be numbered manually if desired. When a fine mesh has been created automatically, the user will have the option to retain all points as grid points or to select points from the mesh to be saved as grid points. The nonselected points will not be saved.

*APT Encyclopedia, Programmers Reference Manual, UNIVAC 1106-1108, UP4078, rev. 2, pp. 9D-1 through 9D-15.

When the grid is to be manually generated, the user will have several alternate methods available for the creation of any grid point. He can position the tracking cross at the desired location (it may be necessary to alter the view to accomplish this), he can use the keyboard to enter X, Y, Z coordinates, or he can enter ΔX , ΔY , ΔZ incremental values. The grid points created can be numbered in a similar manner by entering the grid point number or by incrementing by a delta grid point number. Manual grid point selection will override the mesh established by the FMILL definition of the region if desired.

Another manual option will be available for grid point definition. This option will provide the capability to read a file containing images of NASTRAN GRID cards. The user can delete or modify a previously created grid point at any time during this phase of processing.

Interrogations of the grid can be made at the completion of the automatic operation and at any time during the manual grid creation. Under this control, all grid point numbers can be superimposed on the display, or individual grid points can be selected for interrogation. The user will have the capability to change the coordinates of any grid point. Another option will be available which will permit display of the just completed region, the previously completed regions, and the undivided regions. The capability will also exist to create grid points offset inward at a prescribed distance along the normal to the outer surface.

The structural elements now can be defined and numbered by associating element types with grid points to form the structural model. Fifteen NASTRAN elements will be available for

use in ISAS. They are CBAR, CONROD, CROD, CTUBE, CQDMEM, CQDMEM1, CQDMEM2, CQDPLT, CQUAD1, CQUAD2, CSHEAR, CTRIA1, CTRIA2, CTRMEM, and CTRPLT. Refer to the *NASTRAN User's Manual* NASA SP-222(01) for a description of these elements. Again, the user can select automatic or manual element definition. Automatic element definition will create axial members for stringers and quadrilateral panels for surfaces. Beam elements will be created for the inner surface frames located at inner mold lines.

Element definitions can be manually entered if desired. The terminal user will have options available for the creation of elements and the deletion, modification, and interrogation of previously defined elements. This procedure will be similar to grid point definition; the user can choose to define some or all structural elements by reading NASTRAN bulk data cards.

Another option which can be used to manually create an element will permit the user to manually select the type of element from a menu list of the 15 NASTRAN elements to be included in ISAS. Next, with a light pen, the user will select the nodes (grid points) necessary to define that element. A visual verification of the successfully defined element will then be displayed or a message will be displayed informing the user of an error in the element definition. When the delete option is chosen, the user will select with the light pen the element to be deleted, thus causing it to brighten or blink. This element will be removed from the structural element list, and its display will be deleted from the screen. When the modify option is selected, the user will select with the light pen the element to be modified, causing its display to brighten or blink, and all information concerning the element will be displayed in a form which

can be changed by various interactive devices. Thus, the modify option will also provide a means of interrogating an element.

In order to number the elements during manual creation, the user can choose to enter the element number as he creates the element or to enter a delta element number for incrementing from a base number.

At the completion of automatic element generation or at any time during manual element generation, the display element option can be chosen. The display element option will permit display of either connected or unconnected nodes and particular element types either separately or in combination. It will also permit the user to select a node and display the elements attached to that node. The procedure will be similar to grid spacing; options will be provided to display the elements in the just completed region, in the previously defined region, and the regions whose elements are undefined. When all regions within the substructure have been defined, the user can graphically examine the model, he can go to the procedure for cell (compartment) information entry, or he can choose to proceed to the data edit phase.

As indicated in the description of the structural option, the capability will exist to enter cell information as the model is built or as a separate function. When the cell identification path is chosen, four options will always be available for entering or changing the cell ID's. They are

- Option 1 - Input the two required cell numbers and a substructure ID number. These cell numbers will then be added to the appropriate locations for all elements that exist for that substructure.

- Option 2 - Input the two required cell numbers and two element ID numbers. With this input, the function will add the input cell numbers to all elements that have element ID numbers between the two and including the two input.
- Option 3 - Input one element ID number and change either or both of the cell numbers that already exist for that element.
- Option 4 - Specify a domain by entering two sets of bounding X, Y, Z coordinates or by giving substructure identifications. The two required cell numbers. These cell numbers will be added to the appropriate locations for all elements that exist for that domain.

The capability will exist for performing any of the preceding options in any sequence for any number of times during one execution.

Menu items will be provided to display the element identification numbers, the X, Y, Z coordinates of the centroid, and the two cell numbers for either a selected element or for the entire substructure or domain. There will be symmetry and nonsymmetry options, which may be selected as applicable.

4.31.3.1.2 Aerodynamic Model Generation

When the aerodynamic option is selected, the user will identify the structure and substructure from the Basic Geometry Data File. This will be done as described for the structural option by entering the appropriate ID's or by specifying a rectangular solid. The portion of the model just described will be displayed on the screen.

The zoom, alter view, and restore options will be provided at this stage in the processing function and will always be available during processing.

The user will be asked to specify the model location (fuselage, wing, vertical tail) of the substructure selected because of the difference in type of data to be entered and calculations to be performed. The dialogue will then be slanted toward this specified portion of the aircraft. For example, if the fuselage is selected, the terminal operator will be asked to input the length (L) and the values of X-reference, Y-reference, and Z-reference.

As with the structural option, the region that will be worked will be identified by entering the 1 to 15 character alphanumeric region identification or by using the light pen to select the region directly from the graphical display. Next, the operator will be requested to indicate the symmetry status. If symmetry does not exist or if the user wishes to skip its definition, the page option will be selected. However, if symmetry does exist within the region and this condition is to be used, the symmetry option will be selected. The axis (or axes) of symmetry will be specified, causing flags to be set. This either will activate the mirror image generation of points around a trace when points from 0° to 180° are input or will cause the automatic generation of points when their symmetric counterparts are defined. The symmetry status can be redefined at any time during the model generation.

The next step will involve the creation of cutting planes for the airfoil definitions. The cutting planes will be positioned along the span by specifying the percent of length or percent of span. The number of cutting planes are desired.

The model definition will continue with the grid point spacing or grid point specification. The user will select a cutting plane location and then proceed with the grid point creation. When a cutting plane is selected, the trace of the plane through the model will be displayed. Grid points will be defined around the trace, and depending on the model location selected, other necessary calculations will be made. Two types of traces are depicted in figure 4.31-2. For the fuselage trace, a polar coordinate grid can be displayed lightly over the trace if desired.

The terminal user will have the option of selecting automatic or manual grid generation. He also must identify each segment of the region and indicate the mesh or grid spacing desired for that segment. The segment will be selected by either entering its identification number through the keyboard or by light penning it on the display.

When the grid is to be automatically generated, the user can choose from several regular shells of revolution to generate the desired grid points or he can use the milling machine lofting routine FMILL from the APT system.* If a shell of revolution is selected, the user will be led through the keyboard entries of the necessary dimension and grid spacing specifications. When the FMILL option is selected, the grid spacing will be determined by specifying through the keyboard the number of rows and columns in the grid matrix of the segment. The grid points automatically created will be numbered by using the last numbered point as a base or by using the keyboard to specify the starting number for the segment.

*APT Encyclopedia, Programmers Reference Manual, UNIVAC 1106-1108, UP4078, rev. 2, pp. 9D-1 through 9D-15.

When the grid is to be manually generated, the user will have several alternate methods available for the creation of any grid point. He can position the tracking cross at the desired location (it may be necessary to alter the view to accomplish this), he can use the keyboard to enter X, Y, Z coordinates, or he can enter ΔX , ΔY , ΔZ incremental values. The grid points created can be numbered in a similar manner by entering the grid point number or by incrementing by a delta grid point number. The user can delete or modify a previously created grid point at any time during this phase of processing.

Interrogations of the grid can be made at the completion of the automatic operation and at any time during the manual grid creation. Under this control, all grid point numbers can be superimposed on the display, or individual grid points can be selected for interrogation. Light pen selection of a grid point will cause the grid point to brighten or blink, and its coordinates and number will be displayed. Another option will be available which will permit display of the just completed region, the previously completed regions, and the regions whose elements are undefined. The terminal user will have options available for the creation of airfoil elements and the deletion, modification, and interrogation of previously defined airfoils. When all regions within the substructure have been defined, the user can graphically reexamine the model, he can go to the data edit phase, or he can terminate the job.

4.31.3.2 Data Edit Phase

The purpose of the data edit phase of the User Model File Generator function is to display card image files in a tabular format. This format will permit editing and merging of the files into one file which can be input to batch resequencing programs (if desired) and subsequently input to NASTRAN. The

possible file combinations which can be involved in the data edit phase are as follows. All of the files will be written in the User Model File format.

For a data edit entered from the User Model File Generator, three conditions can exist.

- The New User Model File without editing will be input to the resequencing program where a Resequenced User Model File will be created.
- The New User Model File will be edited forming the Edited/Merged User Model File which will then be input to the resequencing program where a Resequenced User Model File will be created.
- The New User Model File and an Old User Model File will be edited and merged to form the Edited/Merged User Model File which will then be input to the resequencing program where a Resequenced User Model File will be created.

In addition, for a data edit entered directly, three conditions can exist.

- The contents of two previously created User Model Files will be merged and edited to form the Edited/Merged User Model File which will then be input to the resequencing program where a Resequenced User Model File will be created.
- An Old User Model File will be edited forming the Edited/Merged User Model File which will then be input to the resequencing program where a Resequenced User Model File will be created.
- An Old User Model File without editing will be input to the resequencing program where a Resequenced User Model File will be created.

When the data edit phase is entered from the User Model File Generator function, the "new" User Model File name will be automatically retained for the edit activity. When the data edit phase is entered directly, the user will be asked to enter the file name and will be given a display prompting message as described earlier.

Regardless of the path to this point, the terminal operator will be asked if there is another or "old" User Model File he wishes to merge with the other file. If the response is yes, he will then be asked to enter that file name. Another file name will be required if updating or merging is to be performed, and again, that name must be entered. The terminal operator will then proceed with the tabular display and will edit the files to form the desired set of card images. A tabular display of the updated file can be requested to verify and edit, if necessary, the merged file. The user will select the paging option when he is ready to proceed. Next the terminal will be used to enter the name of the resequencing batch program to be used and to enter any other cards needed for the batch run. Another file to contain the output from the batch program must be identified by file name in the same manner. The batch run will then be entered in the computer backlog, and the interactive terminal session will be ended.

4.31.4 OUTPUT

The primary output from this function will be the User Model File and the graphical displays required for the construction and validation of the file. The contents of the file and the displays are discussed in section 4.31.5. A detailed description of the file can be found in the appendix of this document.

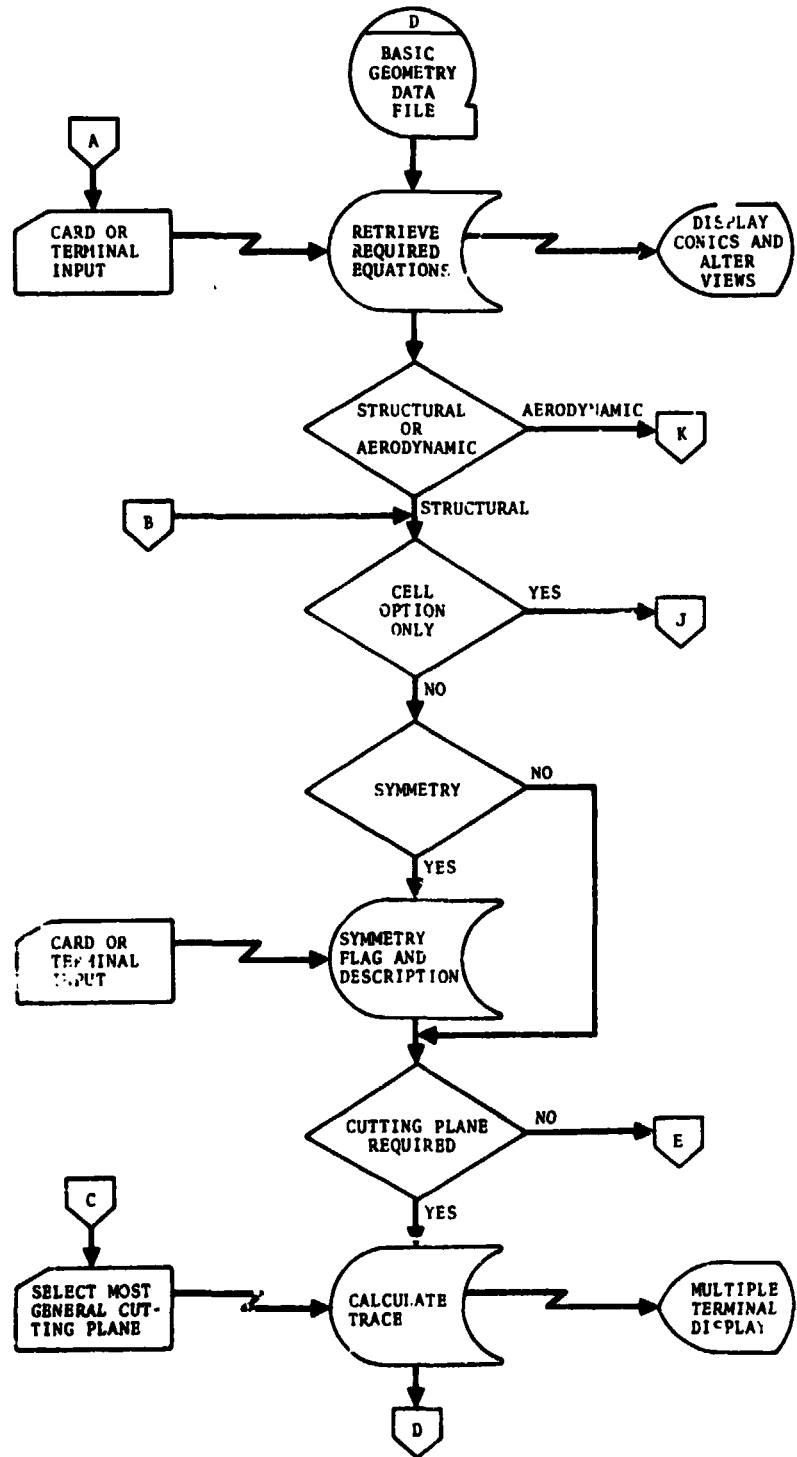

Figure 4.31-1. - Data flow diagram for User Model File Generator.

ORIGINAL PAGE IS
OF POOR QUALITY

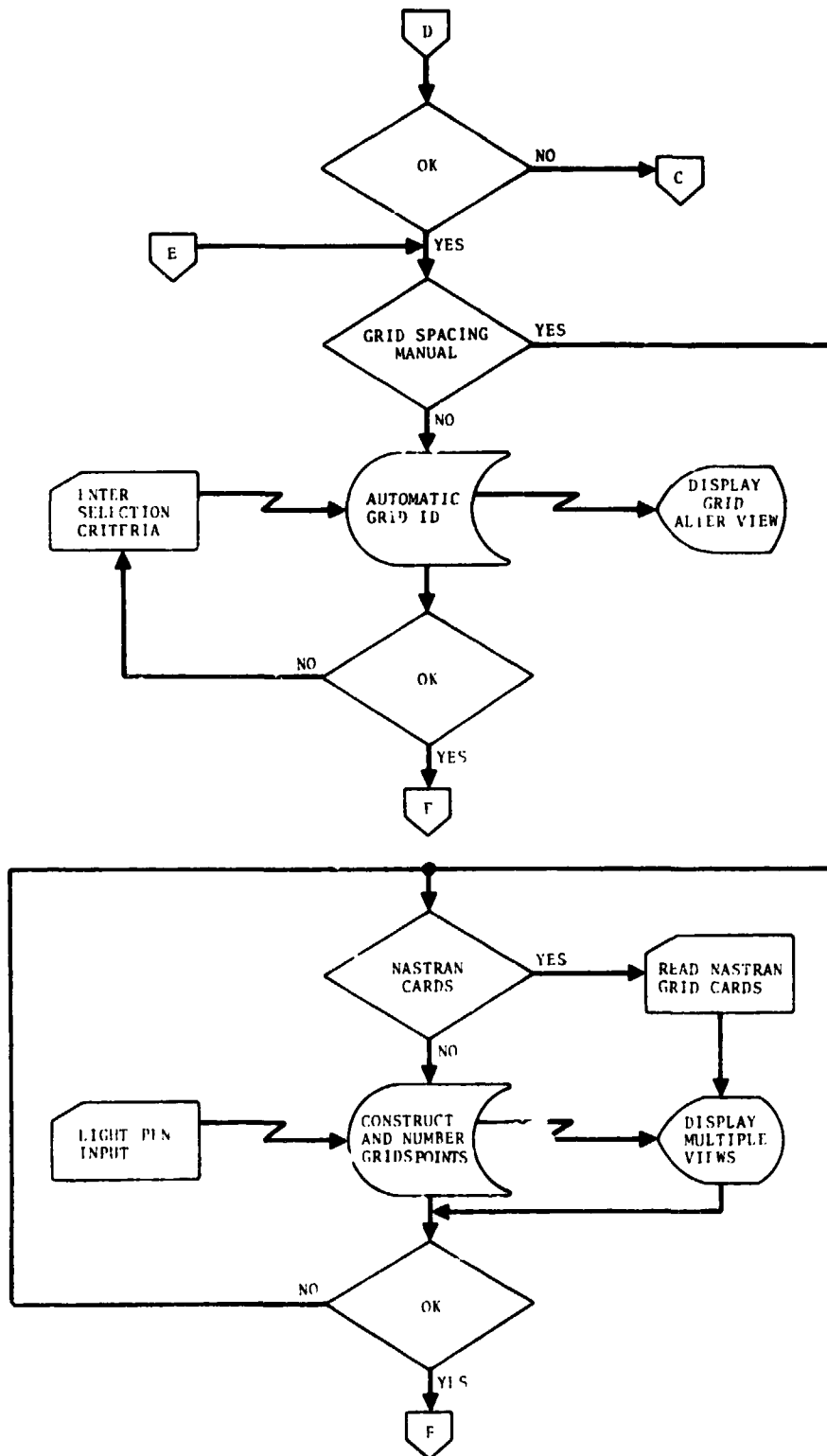
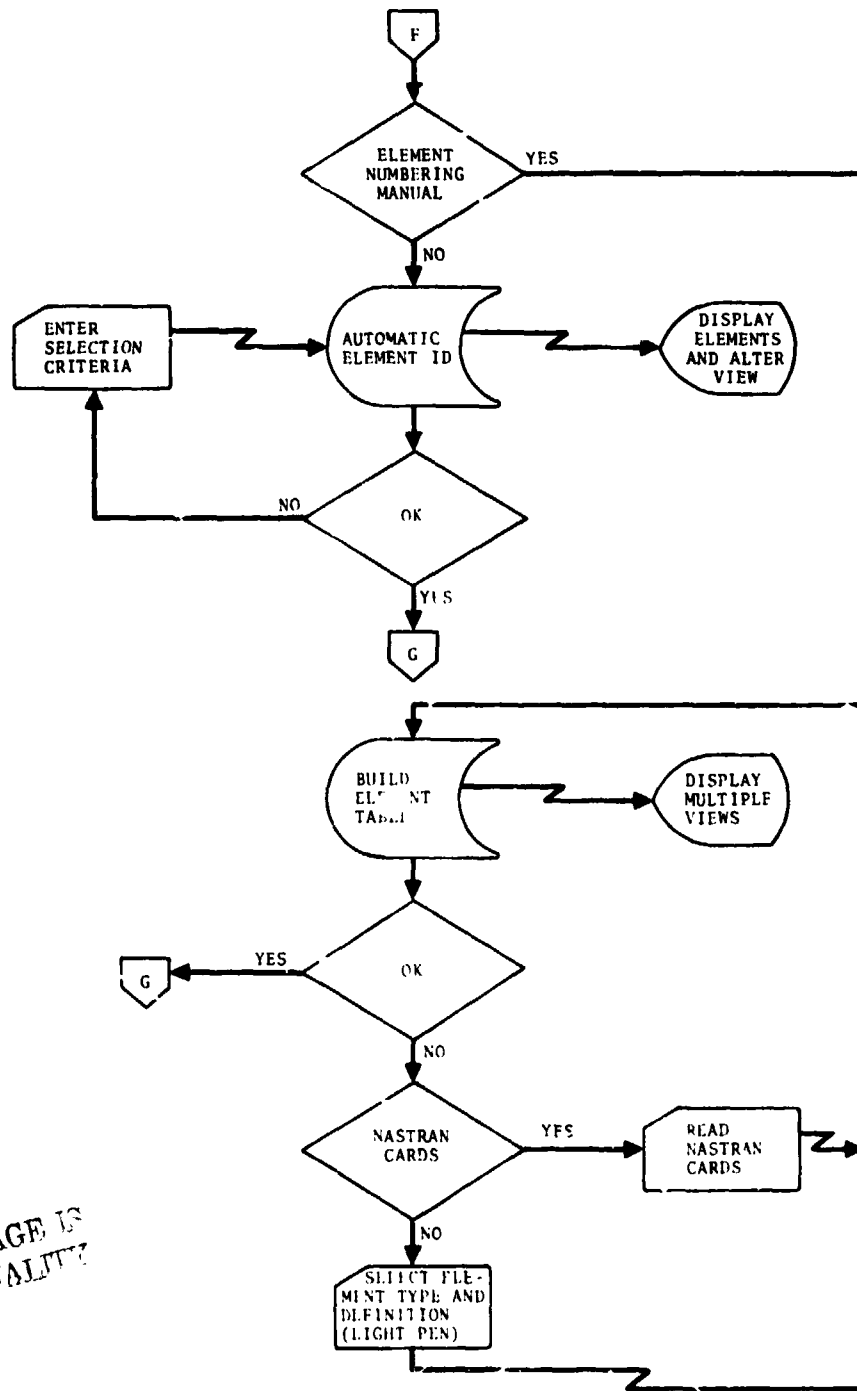

FIGURE 4.31-1 - DATA FLOW DIAGRAM FOR USER MODEL FILE GENERATOR (continued)



ORIGINAL PAGE IS OF POOR QUALITY

FIGURE 4.31-1 - DATA FLOW DIAGRAM FOR USER MODEL FILE GENERATOR (continued)

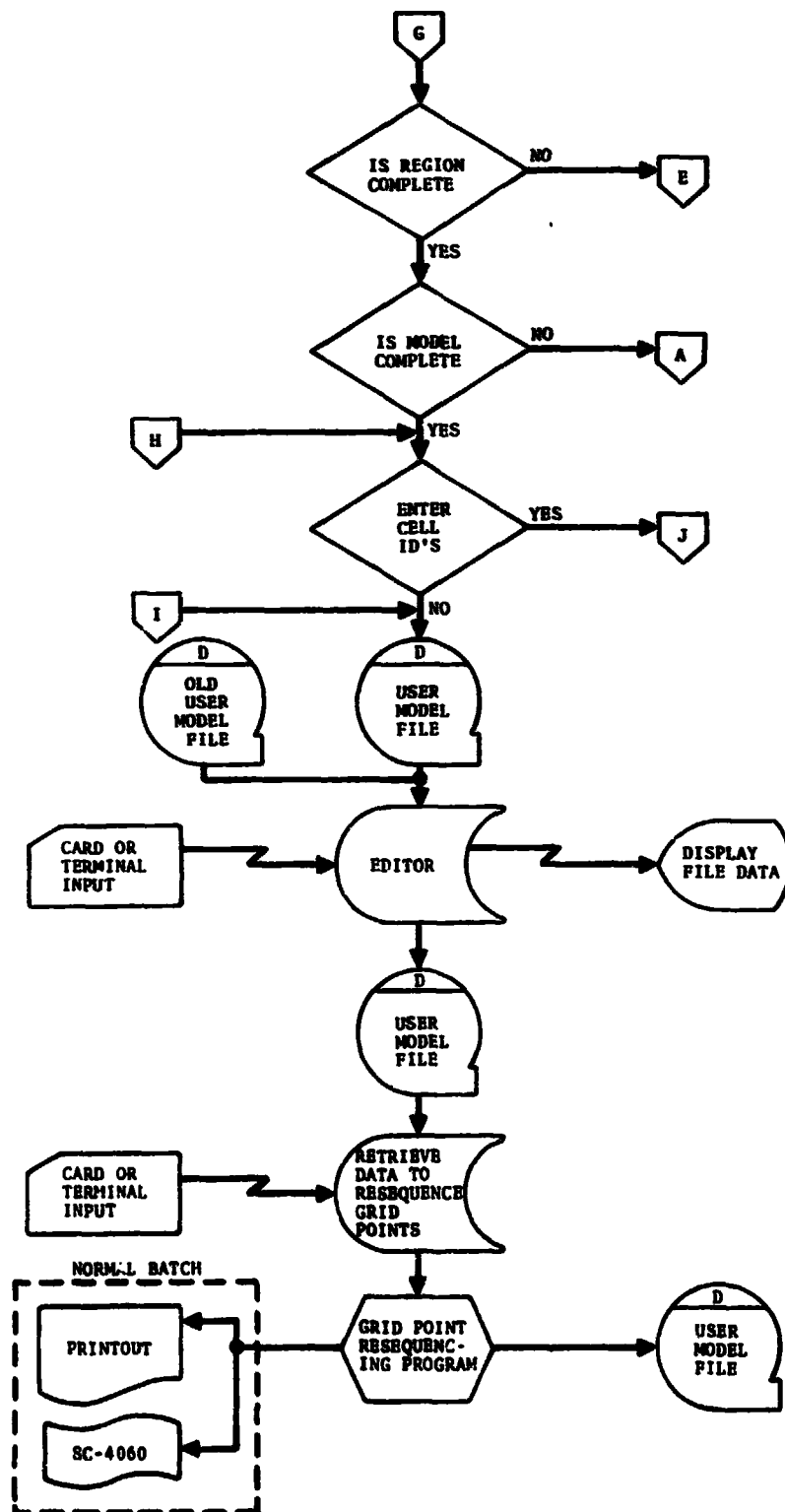
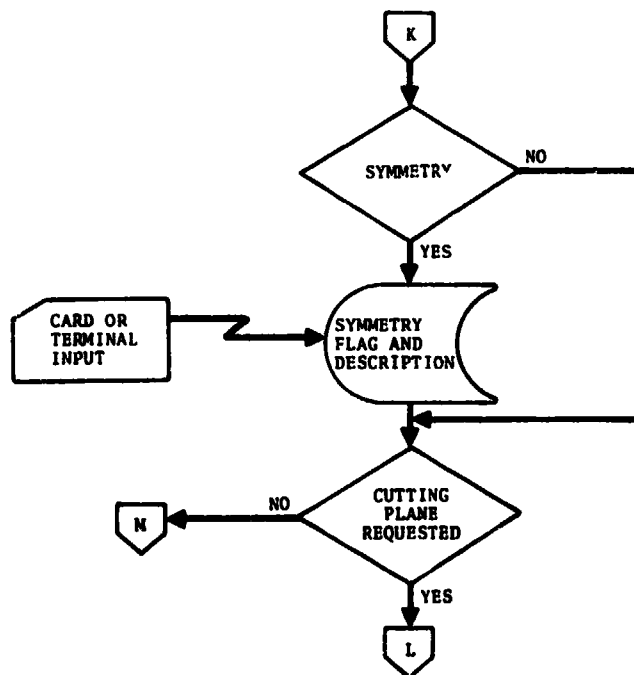
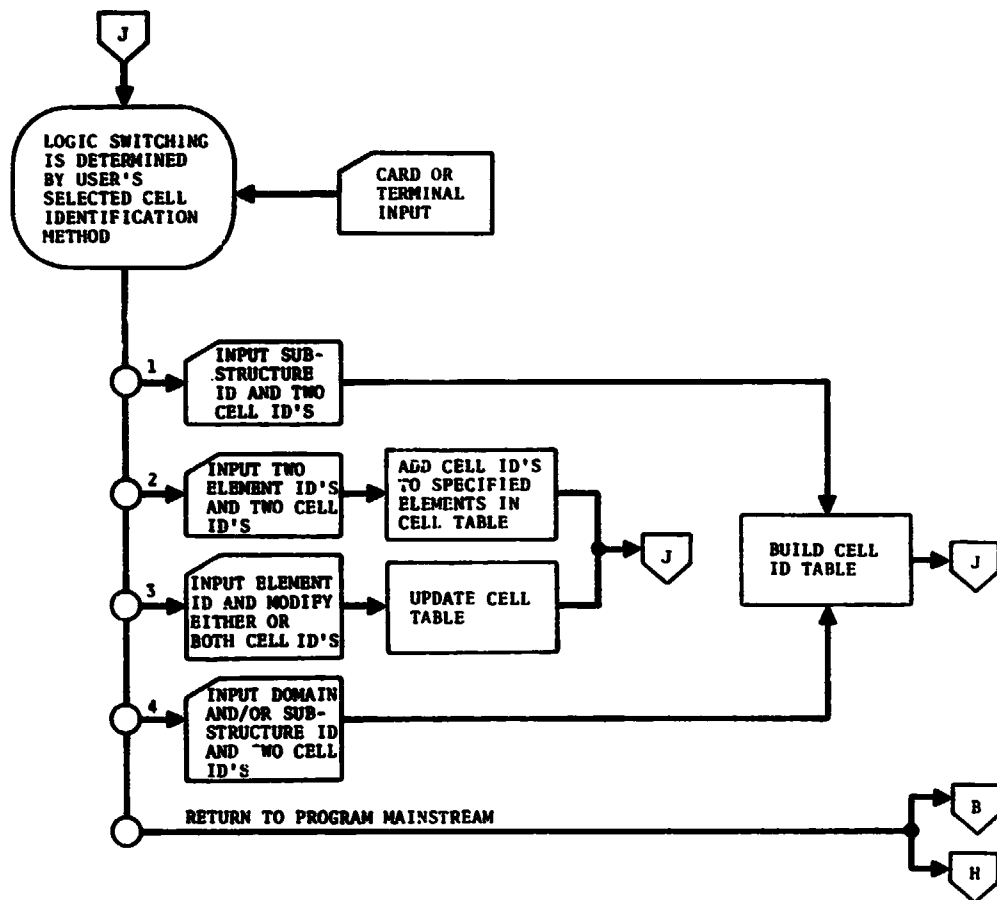

Figure 4.31-1. - Data flow diagram for User Model File Generator (continued).

C.5



ORIGINAL PAGE IS OF POOR QUALITY

Figure 4.31-1. - Data flow diagram for User Model File Generator (continued).

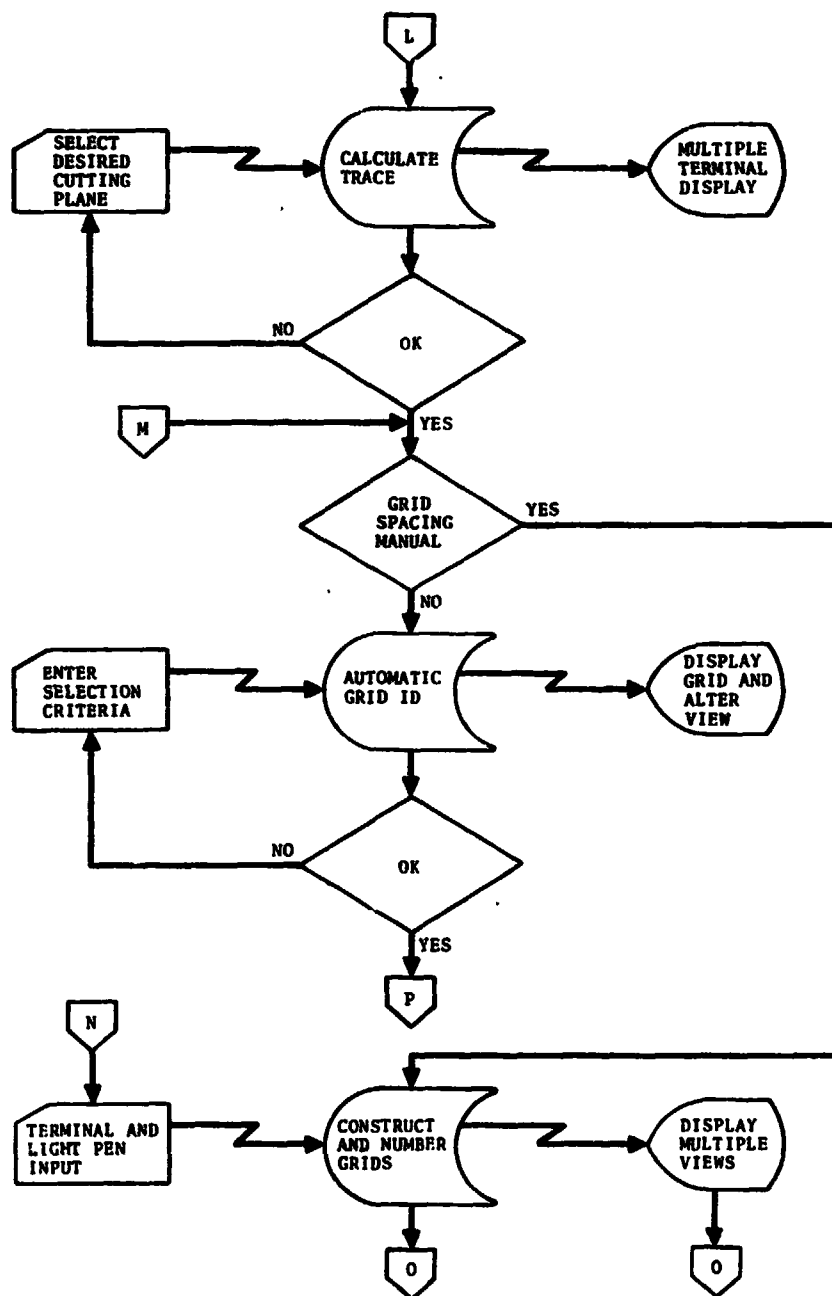
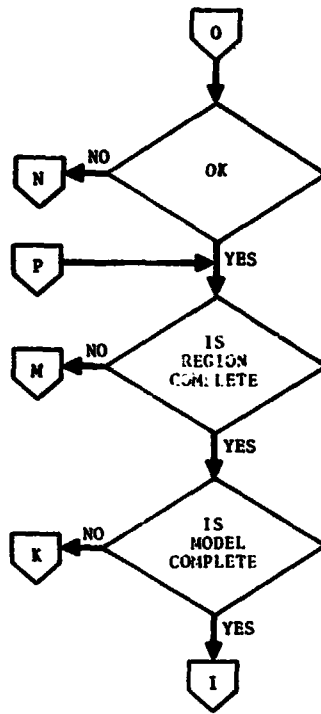
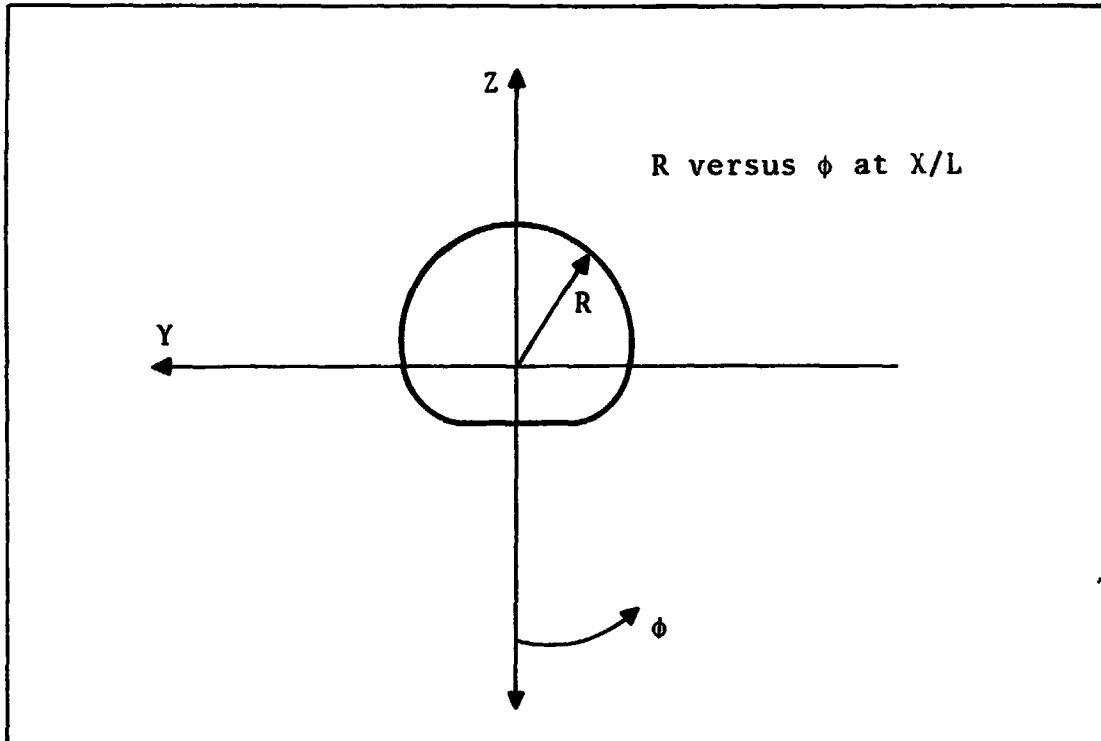

Figure 4.31-1. - Data flow diagram for User Model File Generator (continued).



ORIGINAL PAGE IS
OF POOR QUALITY

Figure 4.31-1. - Data flow diagram for User Model File Generator (concluded).



For fuselage bodies, plot R versus ϕ in polar coordinates at X/L .

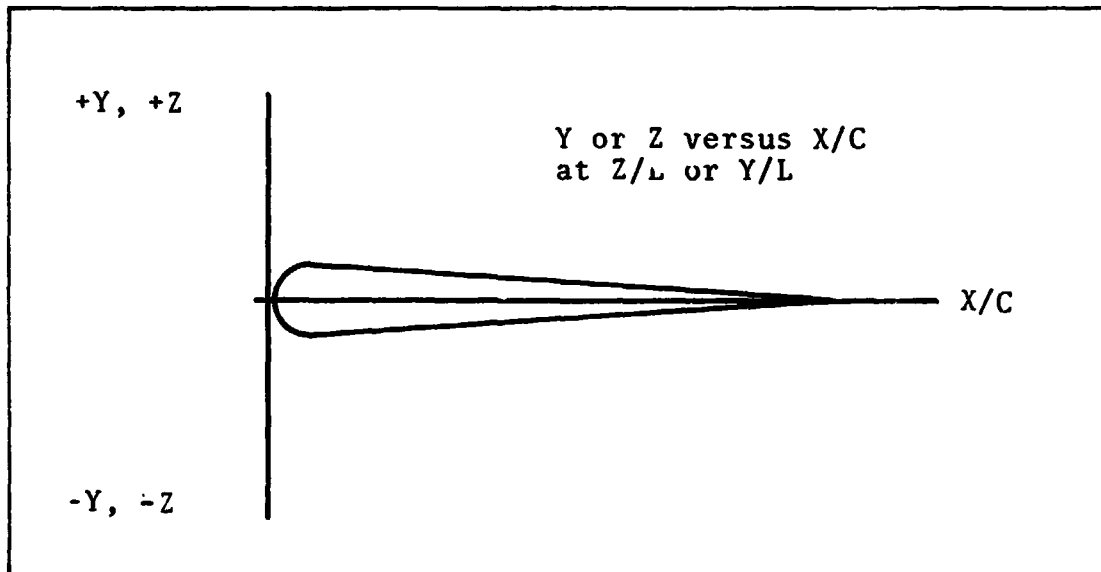

For the wing or vertical tail (and body flap), plot Y versus X/C at Z/L or Z versus X/C at Y/L . Both surfaces must be plotted.

Figure 4.31-2. - Sample traces.

4.32 MODEL WEIGHT FILE GENERATOR

4.32.1 PURPOSE

This function will create a file containing the weight at each structural model grid point for use in structural design and analysis problems. In addition, this function will construct a temporary Model Weight File containing the weight and center of gravity for model subsystems or substructures. Information from this temporary Model Weight File will be used for comparing the structural model weights and the Basic Weight File weights. In addition, a Running Weight File can be created using the Model Weight File. Figure 4.32-1 is a data flow diagram for the Model Weight File Generator.

4.32.2 INPUT

The input data required by this function will be obtained from the User Model File, the Model Material File the Basic Weight File (optional), and interactive terminal entries as needed to develop and verify the structural definition when the Model Weight File is generated. The input will consist of:

- Node numbers, coordinates of each node, and element type from the User Model File
- Nonstructural weights and coordinates of each weight point from the Basic Weight File
- Material density from the Model Material File
- Either keyboard or display-selectable terminal input

4.32.3 PROCESSING

Processing will consist of three major categories (generation of Model Weight File, generation of Running Weight File, data edit phase) each of which will be composed of a number of subprocesses.

The generation of the Model Weight File will include the following subprocesses:

- Selecting and assigning structural weights to the grid points of the model
- Subtotaling weights and calculating the center of gravity by subsystem, substructure, etc., to the lowest identifiable part
- Making comparisons of weight from the Model Weight File (total model structure weight and/or subsection structural weight) with the corresponding weight from the Basic Weight File
- Adding discrete nonstructural weights to the grid point weight to yield the final Model Weight File

The generation of the Running Weight File will include:

- Determining the discrete weights that will not be added to the grid point weights
- Calculating the distributed (or running) weight

The data edit phase will include:

- Tabular display
- Graphics

Visual displays or menus are to be provided which will lead the user through the processing function.

4.32.3.1 Generation of Model Weight File

The Model Weight File generated by this function will contain the following:

- Structural model grid point numbers
- Coordinates of each grid point

- Weight at each grid point, identified as coming from the Basic Weight File or calculated from data from the Model Material File and Element Property File
- Center of gravity of the structural model
- Mass matrix (6×6) for each grid point, which will include the nine mass moments of inertia terms (Calculating the mass matrix will be an option for the terminal user when processing.)

The first step in the processing will be to identify, by name, the files associated with the Model Weight File generation. The file names should be entered from the terminal as they are needed and requested by the display. Each file name should be checked by the EXEC 8 system, and if any file names are not present in the file directory, the terminal user will be informed and given the option of reentering the name or terminating the job. Processing cannot continue until valid file names are entered for the required files.

From the User Model File, the grid point number and grid point coordinates must be extracted. The Model Material File will contain the type of element connecting the model grid points and the element density. Additionally, nonstructural weights and coordinates of each weight point can be obtained from the Basic Weight File. Inclusion of the weights from the Basic Weight File will be optional, and the terminal user will be able to bypass the Basic Weight File input.

When valid file names have been entered, the terminal user will be given the choice of entering the mass moment of inertia terms about the grid points. If the user chooses to enter the terms, the display should provide for entering the grid points and the mass moments of inertia. The number of grid points will be sufficiently large in most instances, so that a total mass matrix and a total mass moment of inertia can be computed from the grid point weights.

At this time, the terminal user should be able to associate the model grid points with the mass grid points. Since each weight from the Basic Weight File will be stored with its coordinates as is each grid point in the User Model File, it will be necessary to assign weights to the grid points of the model. This should be done by linear interpolation or arbitrary assignment by the user. If linear interpolation is chosen, the user must designate the three adjoining grid points for the weights (on inspection of the model), and the weight will then be linearly distributed among the points (see Linear Interpolation section for the description of the method that should be used). If arbitrary assignment is chosen, the grid point number and Cartesian coordinates should be displayed, so that the user can divide the weight arbitrarily from the terminal.

After the weights have been assigned, a temporary Model Weight File should contain the model grid point number, grid point Cartesian coordinates, and interpolated weights (a 6×1 vector for each grid point).

Next, the terminal user should be able to display the temporary Model Weight File card images for inspection and modification. The user can input from the terminal the subtotal calculations that should be made. The subtotals and center of gravity can be calculated for any or all subsystems and substructures, etc., to the lowest identifiable part. The subtotals should be calculated for data in the temporary Model Weight File (just created) and the Basic Weight File (if selected) and should be stored in a temporary data file. The terminal user can request displays of this temporary data file for comparison of subtotals between the temporary Model Weight File and the Basic Weight File. If weight comparisons are not satisfactory, the user will be given the options of rebuilding or changing the Model Weight File or terminating the job.

When the comparison is satisfactory, the next process of adding a discrete or nonstructural weight to yield the final Model Weight File can be initiated. The terminal user will request that the nonstructural weights and their location coordinates from the Basic Weight File be loaded into the Model Weight File. The user can also request that the mass matrix be calculated by dividing the Model Weight File by the gravitational constant. (See the description of the method for deriving the mass matrix in section 4.32.3.4.) Modeling requirements exist in which the mass will not be equal for all coordinate directions per mass point because of structural considerations. Therefore, the terminal user can make arbitrary assignment of the mass for the affected coordinate direction. Then this arbitrary assignment of mass should be entered into the Model Weight File.

After adding the nonstructural weights and calculating the mass matrix, all required data for the Model Weight File will be available. The user should be able to have the file displayed at the terminal. The capability should exist for displaying the mass matrix; also, the vector representing the weight at the model grid points can be displayed at the terminal by referencing the grid point.

4.32.3.2 Processing the Running Weight File

Calculation of the Running Weight File will be an optional procedure for the system user. If the file is to be created, the user will have the option of inputting all of the data or having the system that builds the Running Weight File use data from the Basic Weight File and the structural weight part of the temporary Model Weight File.

In the calculation of running weights, discrete weights of significant magnitude representing nonstructural masses cannot be apportioned to the grid points. Instead, they can be moved in an

orthogonal manner to a line of reference. The user will be requested to make this choice.

The next phase will be the calculation of the distributed or running weight. The structural weight and insignificant non-structural discrete weights will be converted to a distributed weight along the reference line. Some nonstructural weight of significant magnitude will become a distributed or running weight after first being assigned to a grid point.

Two types of records for each of the substructures considered should be available on the file and for display. The discrete weights will be recorded vis-a-vis their Cartesian coordinates, while the running weight will be recorded in pounds per inch along with the Cartesian coordinates of the terminal points which will define the range of the reference line over which the loading applies. Terminal input should include the total reference line range and orientation with the initial entry of model weight data.

4.32.3.3 Linear Interpolation of the Basic Weight File

The division of the weights among three grid points will be accomplished by the use of area coordinates. The weight to be distributed is assumed to be in the plane of the three points (L, M, N). Lines connecting the three points will form a triangle of area A. Three lines drawn from the weight W to the apexes of triangle A will subdivide the triangle into three smaller triangles (l, m, n). The area of a triangle will be equal to one-half of the magnitude of the vector defined by the cross product of two of its sides.

The first step will be to calculate the coordinates \bar{X}_w , \bar{Y}_w , and \bar{Z}_w from the points of interest X_w , Y_w , and Z_w (\bar{X}_w , \bar{Y}_w , and \bar{Z}_w lie in the plane LMN).

$$\frac{\bar{X}_w - X_w}{a} = \frac{\bar{Y}_w - Y_w}{b} = \frac{\bar{Z}_w - Z_w}{c} \quad (1)$$

The variables a , b , and c will be directional numbers from the equation of the plane LMN:

$$a(x - x_L) + b(y - y_L) + c(z - z_L) = 0$$

or

$$ax + by + cz = d \quad (2)$$

Solving (1) explicitly for \bar{X}_w and \bar{Z}_w as functions of \bar{Y}_w , will yield

$$\bar{X}_w = \frac{a}{b}(\bar{Y}_w - Y_w) + X_w \quad \text{and} \quad \bar{Z}_w = \frac{c}{b}(\bar{Y}_w - Y_w) + Z_w$$

Substituting \bar{X}_w and \bar{Z}_w into (2) will yield

$$a\left[\frac{a}{b}(\bar{Y}_w - Y_w) + X_w\right] + b\bar{Y}_w + c\left[\frac{c}{b}(\bar{Y}_w - Y_w) + Z_w\right] = d$$

$$\bar{Y}_w\left(\frac{a^2}{b} + b + \frac{c^2}{b}\right) + a\left(X_w - \frac{a}{b}Y_w\right) + c\left(Z_w - \frac{c}{b}Y_w\right) = d$$

$$\bar{Y}_w = \frac{d + a\left(\frac{a}{b}Y_w - X_w\right) + c\left(\frac{c}{b}Y_w - Z_w\right)}{\left(\frac{a^2}{b} + b + \frac{c^2}{b}\right)}$$

$$\bar{Y}_w = \frac{(a^2 + c^2)Y_w - b(aX_w + cZ_w - d)}{(a^2 + b^2 + c^2)}$$

Similarly,

$$\bar{X}_w = \frac{(b^2 + c^2)X_w - a(bY_w + cZ_w - d)}{(a^2 + b^2 + c^2)}$$

and

$$\bar{Z}_w = \frac{(a^2 + b^2)Z_w - c(aX_w + bY_w - d)}{(a^2 + b^2 + c^2)}$$

The coordinates \bar{X}_w , \bar{Y}_w , and \bar{Z}_w in the plane LMN will be used for the definitions of the vectors \overline{WL} , \overline{WN} , and \overline{WM} .

The cross product of two vectors ($A \times B$) can be defined in determinant form as

$$A \times B = \begin{bmatrix} i & j & k \\ A_x & A_y & A_z \\ B_x & B_y & B_z \end{bmatrix}$$

where i , j , and k are unit vectors. The magnitude of the resulting vector will be twice the area of a triangle, two sides of which are A and B . Thus, linear distribution of a quantity can be easily accomplished given the Cartesian coordinates of the grid point and the point of interest.

$$2A = |\overline{LM} \times \overline{LN}|$$

$$2m = |\overline{WN} \times \overline{WL}|$$

C

$$2n = |\vec{WL} \times \vec{WM}|$$

$$2l = |\vec{WM} \times \vec{WN}|$$

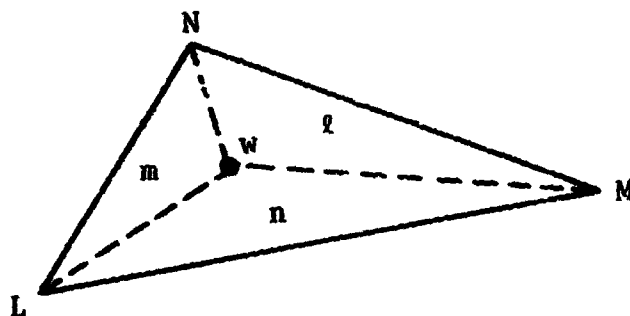

where

A = area of triangle LMN

$$\vec{LM} = (X_m - X_L)\mathbf{i} + (Y_m - Y_L)\mathbf{j} + (Z_m - Z_L)\mathbf{k}$$

$$\vec{LN} = (X_N - X_L)\mathbf{i} + (Y_N - Y_L)\mathbf{j} + (Z_N - Z_L)\mathbf{k}$$

$$\vec{WL} = (\bar{X}_w - X_L)\mathbf{i} + (\bar{Y}_w - Y_L)\mathbf{j} + (\bar{Z}_w - Z_L)\mathbf{k}$$

$$\vec{WN} = (\bar{X}_w - X_N)\mathbf{i} + (\bar{Y}_w - Y_N)\mathbf{j} + (\bar{Z}_w - Z_N)\mathbf{k}$$

$$\vec{WM} = (\bar{X}_w - X_m)\mathbf{i} + (\bar{Y}_w - Y_m)\mathbf{j} + (\bar{Z}_w - Z_m)\mathbf{k}$$

The weight W will be distributed to the three grid points N, L, and M as follows:

$$W_N = \frac{n}{A}W$$

$$W_L = \frac{l}{A}W$$

$$W_M = \frac{m}{A}W$$

The interpolated value for W will be

$$W = \frac{W_L l + W_M m + W_N n}{A}$$

4.32.3.4 Derivation of Mass Matrix for Each Grid Point

The mass properties per grid point about some reference point or the mass center of gravity will be

$$\begin{bmatrix} \mathbf{I} & \mathbf{0} \\ \mathbf{X} & \mathbf{I} \end{bmatrix} \begin{bmatrix} \mathbf{M} & \mathbf{0} \\ \mathbf{0} & \mathbf{0} \end{bmatrix} \begin{bmatrix} \mathbf{I} & \mathbf{X}^T \\ \mathbf{0} & \mathbf{I} \end{bmatrix}$$

$$\begin{bmatrix} \mathbf{M} & \mathbf{0} \\ \mathbf{XM} & \mathbf{0} \end{bmatrix} \begin{bmatrix} \mathbf{I} & \mathbf{X}^T \\ \mathbf{0} & \mathbf{I} \end{bmatrix} = \begin{bmatrix} \mathbf{M} & \mathbf{MX}^T \\ \mathbf{XM} & \mathbf{XMX}^T \end{bmatrix}$$

Or in expanded notation, the mass properties per grid point will be

$$\begin{bmatrix} M_x & 0 & 0 & 0 & ZM_x & -YM_x \\ 0 & M_y & 0 & -ZM_y & 0 & XM_y \\ 0 & 0 & M_z & YM_z & -XM_z & 0 \\ 0 & -ZM_y & YM_z & I_{xx} & I_{xy} & I_{xz} \\ ZM_x & 0 & -XM_z & I_{xy} & I_{yy} & I_{yz} \\ -YM_x & XM_y & 0 & I_{xz} & I_{yz} & I_{zz} \end{bmatrix}$$

where

$$I_{xx} = z^2 M_y + y^2 M_z$$

$$I_{yy} = z^2 M_x + x^2 M_z$$

$$I_{zz} = y^2 M_x + x^2 M_y$$

$$I_{xy} = -xy M_z$$

$$I_{xz} = -xz M_y$$

$$I_{yz} = -yz M_x$$

Coordinate distances from mass points to the center of total mass of the structure will be X, Y, and Z.

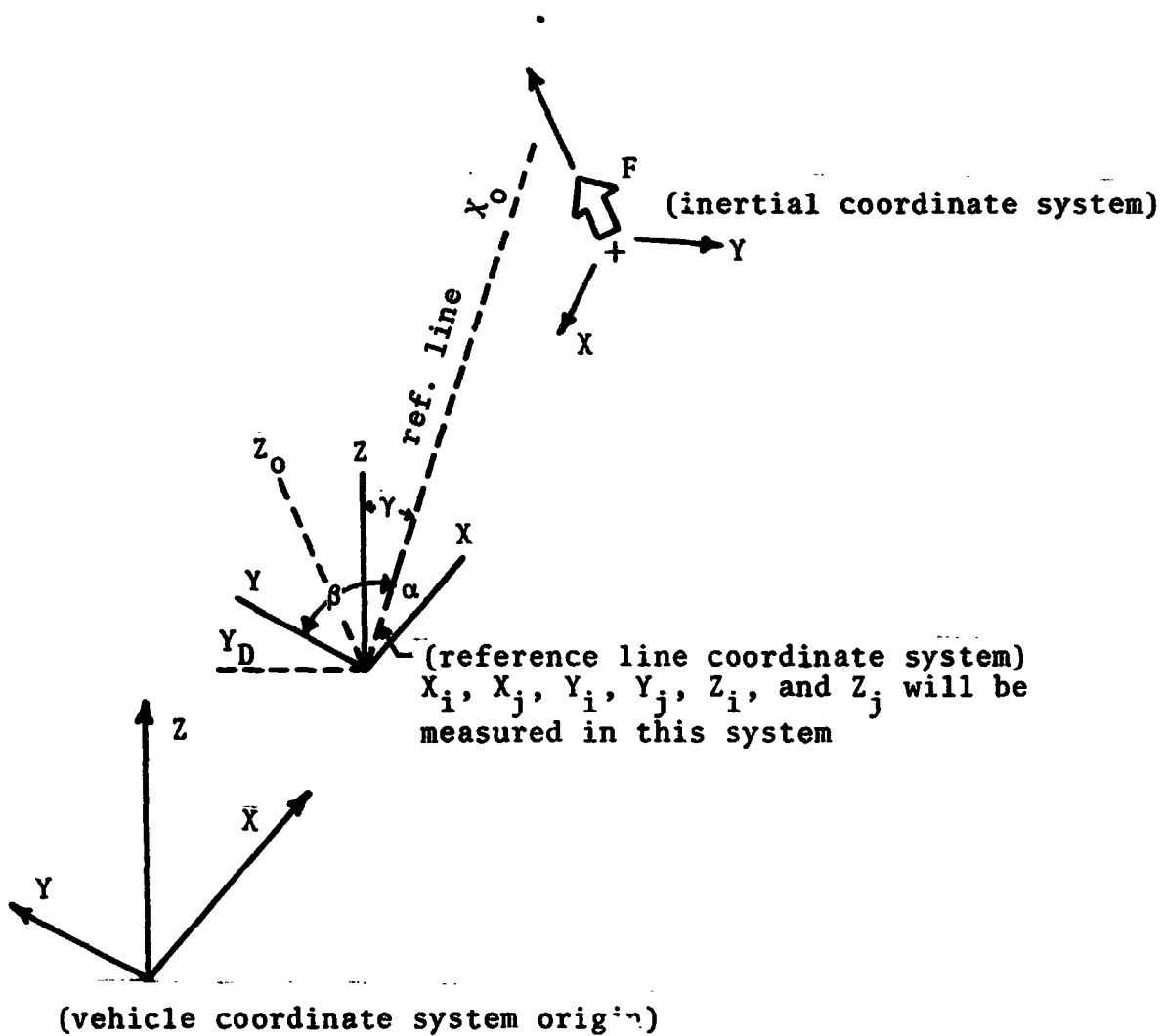

$$R_{OF} = \begin{bmatrix} \lambda_{OF} & 0 \\ 0 & \lambda_{OF} \end{bmatrix} \quad R = \begin{bmatrix} \lambda & 0 \\ 0 & \lambda \end{bmatrix} \quad T = \begin{bmatrix} I & 0 \\ X & I \end{bmatrix}$$

(6 × 6) (6 × 6) (6 × 6)

where

λ_{OF} - direction cosines of inertial and reference line coordinate systems

λ - direction cosines of vehicle and reference line coordinate systems

I - unit matrix

O - null matrix

$$X = \begin{bmatrix} 0 & -(Z_j - Z_i) & (Y_j - Y_i) \\ (Z_j - Z_i) & 0 & -(X_j - X_i) \\ -(Y_j - Y_i) & (X_j - X_i) & 0 \end{bmatrix}$$

4.32.4 OUTPUT

The primary output from this function will be the Model Weight File. In addition, the Running Weight File will be an optional output file.

The user can request output (tabulations and displays) as the files are being created.

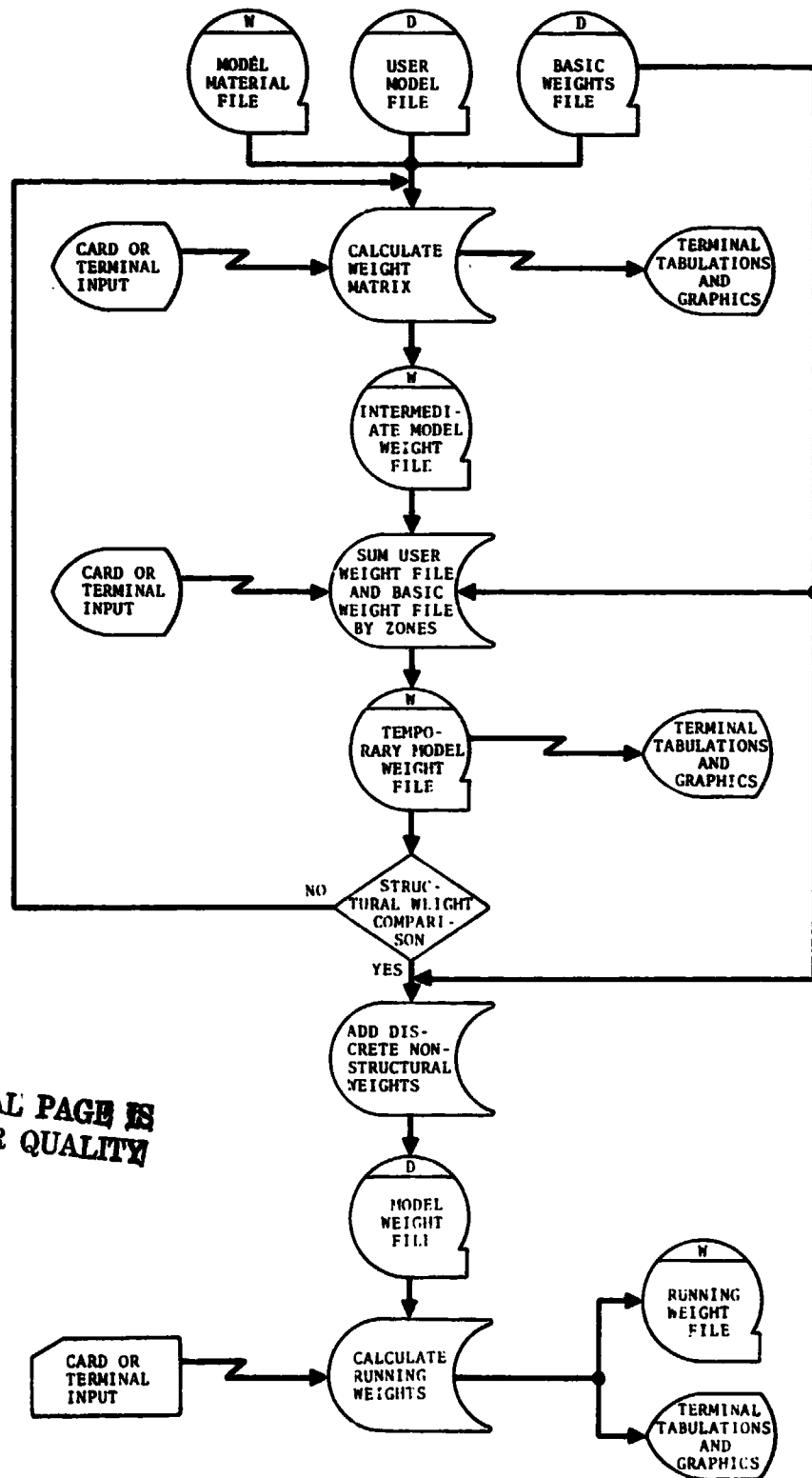

ORIGINAL PAGE IS
OF POOR QUALITY

Figure 4.32-1. - Data flow diagram for Model Weight File Generator.

4.33 VENTING ANALYSIS

4.33.1 PURPOSE

This function will be used to provide remote terminal displays (tabulations and graphics) of data retrieved from the C_p at Required Points File and the VADIC Output File. The standard feature of data editing should also be provided in this function. Figure 4.33-1 is a data flow diagram of the Venting Analysis function.

4.33.2 INPUT

The only two files input to this demand function are the C_p at Required Points File and the VADIC Output File (see the appendix). Some manual input at the remote terminal will be required in order to control the function and to edit the data. The batch program which will be used in conjunction with this function will obtain data from the Standard Atmosphere File and the Trajectory Data File. However, no capability is required of the demand function in respect to these files.

4.33.3 PROCESSING

The only processing required of this function will be the construction of displays for the remote terminal (see section 4.33.4). No calculations will be performed, and no data files will be created.

4.33.4 OUTPUT

The display capability described in the section for the Aerodynamic Data Base Generator will be required for the C_p at Required Points File. An additional three types of tabulation are required. For the case where one Mach number, a few angles of attack (α), and several angles of sideslip (β) exist, the pressure coefficients will be tabulated as shown in figure 4.33-2. If additional pages are required in order to have columns for

the different angles of sideslip, they should be in the same format. The reverse case will also exist where there are only two or three angles of sideslip and many angles of attack. In this event, the data should be tabulated in the format shown by figure 4.33-3. The third type of tabulation (figure 4.33-4) will be used when there are only one or two angles of attack and angles of sideslip but several Mach numbers.

Three types of graphical displays are required for data extracted from the C_p at Required Points File. Figure 4.33-5 shows an example of the first plot type. At a given X station, angular position on fuselage about X axis (ϕ), and angle of sideslip, the interpolated pressure coefficients (C_p) will be plotted versus Mach number. All data for all angles of attack should be plotted.

The second type will be similar to the first except that C_p will be plotted versus X vehicle station for a specified Mach number, angle of sideslip, and ϕ . An example of this type of plot is shown in figure 4.33-6. A plot of the vehicle at the given ϕ is also shown at the bottom of the plot.

For the third type of plot, the vehicle cross section at a given X station will be plotted surrounded by a plot of the pressure coefficients at all values for ϕ . Also, a reference guide for C_p equals zero should be plotted about the cross section. Figure 4.33-7 shows an example of this plot type.

All plots required of data from the VADIC Output Data File will conform to the example shown in figure 4.33-8. These plots will be either ambient pressure (P_∞), dynamic pressure (q), or cell pressure plotted versus time.

Tabulation displays will be generated in one of two formats for data from the VADIC Output File. Figure 4.33-9 is the first

type, and it shows how dynamic pressure and ambient pressure should be tabulated versus time. The second format (figure 4.33-10) should be used when cell (compartment) pressure is tabulated versus time.

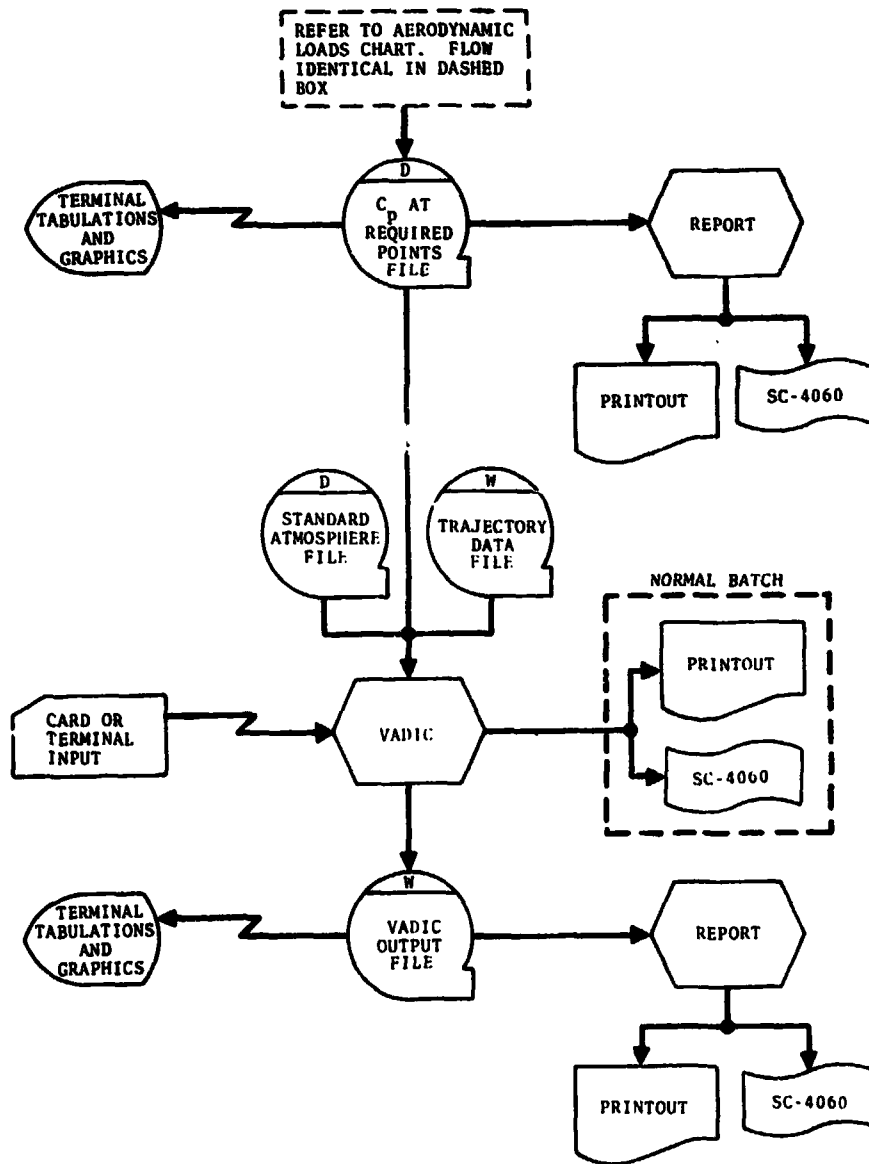

ORIGINAL PAGE IS
OF POOR QUALITY

Figure 4.33-1. - Data flow diagram for Venting Analysis.

TITLE

MACH NUMBER = XX.X

ALPHA = XX.XX

STATION			BETA = X.X	BETA = X.X	BETA = X.X
X	Y	Z	Cp	Cp	Cp
.
.
.

Figure 4.33-2. — Example tabulation of pressure coefficients for several angles of sideslip.

TITLE

MACH NUMBER = XX.X

BETA = XX.XX

STATION			ALPHA = X.X	ALPHA = X.X	ALPHA = X.X
X	Y	Z	Cp	Cp	Cp
.
.
.

Figure 4.33-3. — Example tabulation of pressure coefficients for many angles of attack.

TITLE						
ALPHA = XX.X			BETA = XX.X			
STATION			MACH = X.X	MACH = X.X	MACH = X.X	
X	Y	Z	Cp	Cp	Cp	
.	
.	
.	

Figure 4.33-4. — Example tabulation of pressure coefficients for several Mach numbers.

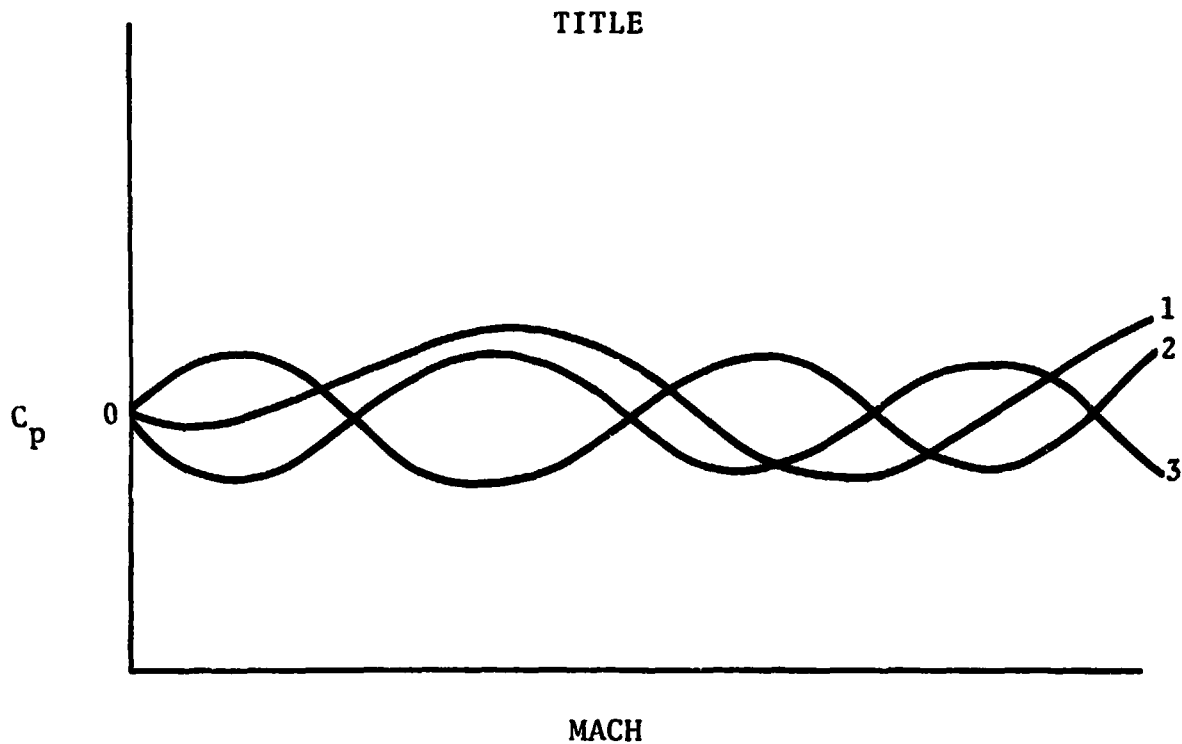

ALPHA 1 = XX.XX BETA =
 ALPHA 2 = XX.X DELTA E =
 ALPHA 3 = XX.X DELTA R =
 STATION =
 X FOR FUSELAGE, Y FOR WING, Z FOR TAIL* =
 SECOND DIMENSION VARIABLE =
 φ FOR FUSELAGE, X/C_w FOR WING, X/C_v FOR TAIL* =

*The user will have indicated to the program which part (fuselage, wing, or tail) of the vehicle is being studied.

Figure 4.33-5. - Example of plot for pressure versus Mach.

TITLE

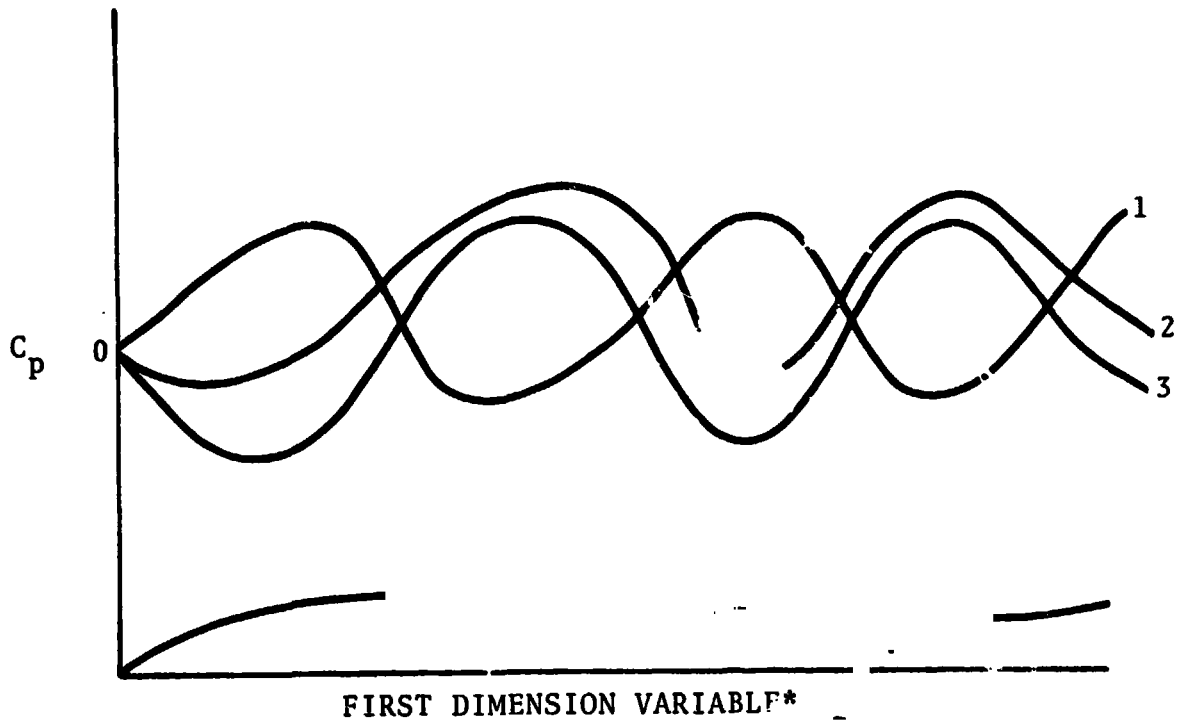

ALPHA 1 = XX.X
ALPHA 2 = XX.X
ALPHA 3 = XX.X

DRAWING OF THE VEHICLE
AT THE PARTICULAR VALUE
OF THE SECOND DIMENSION
VARIABLE †

MACH = XXX
BETA = XXX
DELTA E = XX
DELTA R = XX
PHI = XX.X

*First dimension variable (station) = X for fuselage,
Y for wing, and Z for tail.

†Second dimension variable = ϕ for fuselage, X/C_w for
wing, and X/C_v for tail.

The user will have indicated to the program which part
(fuselage, wing, or tail) is being studied and the correct
dimension variable will be used.

Figure 4.33-6. - Example of plot for pressure versus
X vehicle station.

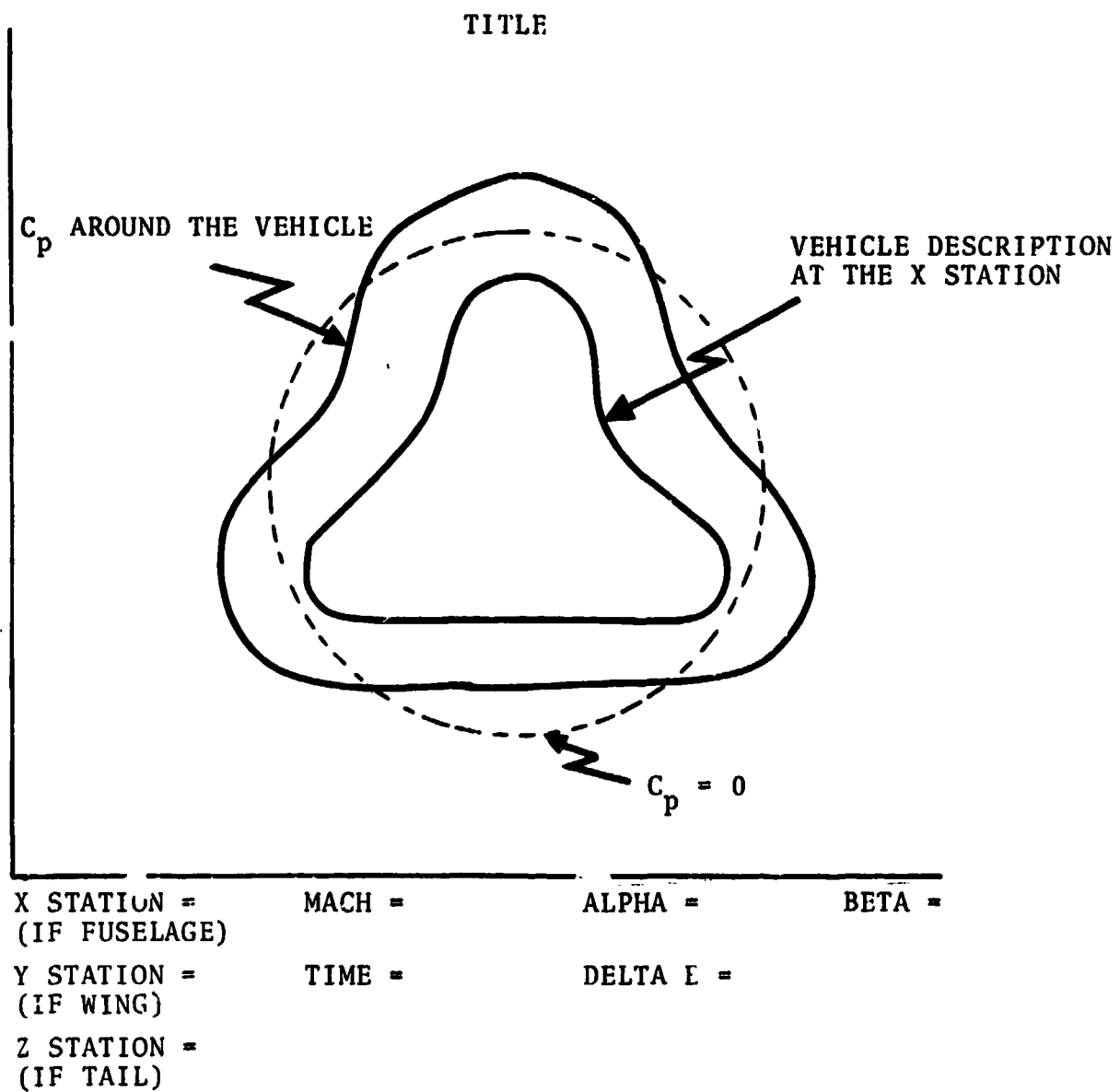
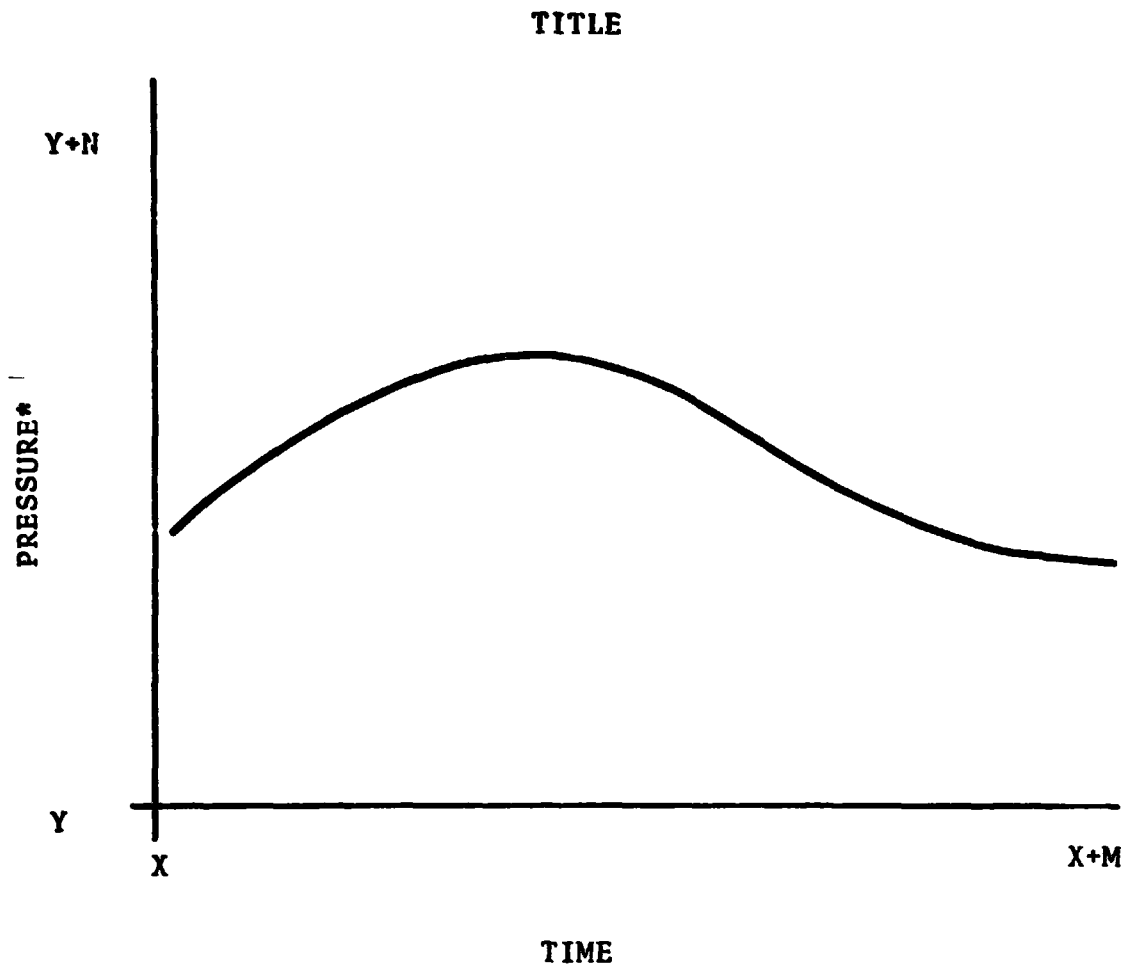

Figure 4.33-7. - Example of plot for vehicle cross section at a given X station.



*The pressure plotted against time may be either:

- (1) Dynamic pressure (q)
- (2) Ambient pressure (P_{∞})
- (3) Cell pressure (one plot per cell); if cell pressure, cell numbers or cell names will be displayed.

Figure 4.33-8. — ' plot for pressure versus time.

	TITLE	
TIME	DYNAMIC PRESSURE	AMBIENT PRESSURE
.	.	.
.	.	.
.	.	.

Figure 4.33-9. - VADIC output data.

	TITLE			
TIME =	CELL NUMBER	CELL PRESSURE	CELL NUMBER	CELL PRESSURE
.
.
.

Figure 4.33-10. - Tabulation format for cell pressure versus time.

5. PERFORMANCE REQUIREMENTS

5.1 RESPONSE TIME

Response time is defined to be the interval between the start of an event and the system response to that event. The start of an event is defined as the completion of the last user-required task that elicits a response, and the end of an event is the completion of the response by the system. The following list of structural displays defines the necessary interaction (required by ISAS) with specific response time requirements and estimates of percent usage for each display type.

Response Time and Usage

Display Type

Less than 1 second each, eighty-percent usage	● Character displays
	● Vector (line between two points)
	● Translation of displayed objects
	● Rotation of displayed objects
	● Zoom into/out of displayed structures
	● Point detection when selected by light pen
	● Point detection when selected by tracking cross
Less than 4 seconds each, fifteen-percent usage	● Minimum configuration displays (less than 1000 points)
	● Average configuration displays (less than 3000 points)
	● Plots
Less than 10 seconds, two-percent usage	● Hardcopy

Less than 20 seconds,
one-percent usage

- Maximum configuration displays
(less than 10,000 points)

Greater than 20 seconds
each, two-percent usage

- Not considered conversational
interaction
- Some complex task may require
this amount of time; however, the
system must give some indication
that the task is being performed.

5.2 AVAILABILITY

For the normal mode of operation, ISAS requires the availability of the interactive graphics system for 8 hours per day during the prime shift. Also, this hardware is required on a regular basis for 4 or more hours per day during the nonprime shift. The UNIVAC 1110 to Adage communication link must be available at all times when the graphics hardware is in use. An additional line will be required to drive a teletype compatible CRT located in Building 13.

It is estimated that the ISAS development will require approximately 1 standard unit of processing (SUP) hour per week. When ISAS reaches a productional state, the computer time requirement could reach 20 SUP hours per week. The computer time requirement is reflected in the Engineering and Development Directorates computer resource requirements.

All of the data required by ISAS could approach 60 to 75 million words of mass storage. However, since the Space Shuttle analysis will be phased, it is reasonable to estimate that only 22 million words will be required to reside in mass storage at any one time.

5.3 STABILITY/RELIABILITY

The stability of the UNIVAC 1110 must be maintained for a period greater than 8 hours between failures during the prime shift. Due to the size of the analysis to be performed, any less stability would be considered unreliable. The maximum duration for a Univac

1110 failure must not exceed 4 hours in order to not affect the ISAS project. The stability of the interactive graphics system should be equal or better than the UNIVAC 1110. Corrective action must be initiated within 24 hours of any Adage hardware problem detection. The Scientific Computing Branch (FD3) is responsible for monitoring the Adage hardware maintenance for the ISAS Adage System. ISAS will be designed so that it will operate on either Adage GS340 system.

5.4 HUMAN FACTORS

The system must be designed in such a manner that the user need not be a data processing expert. The system should not require the user to make frequent reference to literature such as an *ISAS User's Guide* or the *EXEC 8 Reference Manual*.

The user will control the operation of ISAS via a remote interactive terminal equipped with a high resolution graphics display. This control will include recalling data from storage, loading the applications programs into the host computer, retrieving the output from the host computer, displaying the data in various ways, and the capability of adding, deleting or modifying the parameters used in the thermal analysis programs.

6. IMPLEMENTATION

6.1 DATA BASE ESTABLISHMENT

The technical content, structure, source, and other information about the data files which comprise the data base are described in the appendix. The files are arranged alphabetically and are designed to provide data to all users and reduce the time required to retrieve any data segment. Common data storage and retrieval routines will be developed for data files which are used by one ISAS function.

6.2 OPERATIONAL STAGES

All of the ISAS functions described in this document will be developed as a single operating system. However, each function will be developed, tested, and made available to the user as it is completed. When all functions have been completed, the total system will undergo integrated testing and then be officially released.

APPENDIX
FILE DESCRIPTIONS

APPENDIX - FILE DESCRIPTIONS
CONTENTS

File	Page
ACE DATA FILE.	A-1
ACE OUTPUT DATA FILE	A-2
AERODYNAMIC DATA BASE.	A-5
AERODYNAMIC DATA FILE.	A-17
AERODYNAMIC INFLUENCE COEFFICIENTS FILE.	A-19
AEROELASTICITY DATA BASE	A-20
AEROELASTICITY INFLUENCE COEFFICIENTS FILE	A-21
AIRCRAFT PLOT DATA FILE.	A-22
BASIC DATA FILE.	A-24
BASIC GEOMETRY DATA FILE	A-25
BASIC STRUCTURAL DIMENSIONS FILE	A-32
BASIC WEIGHT FILE.	A-33
BATCH FLIGHT CONDITIONS FILE	A-34
BODY LOADS FILE.	A-39
BOOST AND AIRCRAFT FLIGHT CONDITIONS FILE.	A-44
BOOST PLOT DATA FILE	A-45
COMBINED DATA FILE	A-46
COMPRESSED AERODYNAMIC FORCES AND CONDITIONS FILE.	A-47
C_p AT REQUIRED POINTS FILE	A-53
ELEMENT PROPERTY FILE.	A-54
EXTERNAL PRESSURE FILE	A-55
FATIGUE INPUT DATA FILE.	A-58

File	Page
FATIGUE OUTPUT DATA FILE	A-59
FATIGUE SPECTRAL DATA FILE	A-60
FEEDLINE MODAL DATA FILE	A-61
FORCE COEFFICIENT DATA FILE.	A-62
FORCE COEFFICIENT FILE	A-72
GUST INPUT FILE.	A-74
INPUT FLIGHT CONDITIONS FILE	A-75
INTERIM AERODYNAMIC DATA FILE.	A-76
INTERIM PROPERTIES AND ALLOWABLES FILE	A-77
INTERIM SADSAC DATA FILE	A-79
INTERMEDIATE MODEL WEIGHT FILE	A-80
INTERPOLATED CONTROL POINT FILE.	A-81
INTERPOLATED STRUCTURAL DATA FILE.	A-83
ISAS FLIGHT CONDITIONS FILE.	A-84
LIFTING SURFACE FLUTTER INPUT FILE	A-89
LIFTING SURFACE FLUTTER OUTPUT FILE.	A-90
LINEAR SYSTEMS DYNAMICS PROGRAM OUTPUT FILE.	A-92
LOAD COEFFICIENT DATA FILE	A-93
LOAD COEFFICIENT NAMELIST INPUT DATA FILE.	A-100
LOAD INPUT DATA FILE	A-101
LOAD OUTPUT FILE	A-106
MASS/GRID/MODAL FILE	A-107
MATERIAL DATA FILE	A-108
MAXIMUM LOADS DATA FILE.	A-109
MERGED FLIGHT CONDITIONS FILE.	A-110

File	Page
MODEL LOADS FILE	A-111
MODEL MATERIAL FILE.	A-113
MODEL TEMPERATURE FILE	A-114
MODEL WEIGHT FILE.	A-115
MODIFIED BODY LOADS FILE	A-117
MOVIE INPUT FILE	A-118
NAPSAP OUTPUT DATA FILE.	A-119
NASTRAN INPUT LOADS FILE	A-120
NASTRAN OUTPUT-2 FILE.	A-123
NASTRAN SORTED DATA FILE	A-125
PANEL FLUTTER INPUT FILE	A-126
PANEL FLUTTER OUTPUT FILE.	A-128
RESPONSE OUTPUT FILE	A-131
RUNNING WEIGHT FILE.	A-132
RUNSTREAM INPUT FILE	A-133
SADSAC TAPE.	A-135
SCRIBL OUTPUT FILE	A-147
SECTION PROPERTIES AND ALLOWABLES FILE	A-151
SELECTED MODAL DATA FILE	A-153
SKIN FRICTION DATA FILE.	A-154
STANDARD ATMOSPHERE FILE	A-155
STATIC AERODYNAMIC INFLUENCE COEFFICIENTS FILE	A-156
STATIC AEROELASTICITY FORCE COEFFICIENT DATA FILE.	A-157
STATIC AEROELASTICITY INPUT FILE	A-158
STATIC AEROELASTICITY OUTPUT FILE.	A-162

File	Page
STIFFNESS, MASS, AND MODES FILE.	A-164
STRESS DATA FILE	A-165
STRUCTURAL ALLOWABLE DATA FILE	A-166
STRUCTURAL INFLUENCE COEFFICIENTS FILE	A-168
TEMPERATURE DATA FILE.	A-169
TEMPORARY MODEL WEIGHT FILE.	A-171
TRAJECTORY DATA FILE	A-172
TRANSFORM EQUATIONS FILE	A-173
TURBULENCE SPECTRA FILE.	A-174
UNSTEADY AERODYNAMIC GENERALIZED FORCES FILE	A-175
UNSTEADY AERODYNAMIC INPUT FILE.	A-176
UNSTEADY AERODYNAMIC OUTPUT FILE	A-178
UNSTEADY FLUTTER GENERALIZED FORCES FILE	A-180
UNSTEADY GUST GENERALIZED FORCES FILE.	A-181
USER MODAL FILE.	A-182
USER MODEL FILE.	A-185
VADIC OUTPUT FILE.	A-203
WINDS ALOFT DATA FILE.	A-206

ACE DATA FILE

TBD

ACE OUTPUT DATA FILE

GENERAL

This data file will contain calculated pressure coefficients (C_p) for area panel control points on the vehicle.

Type of interface: I
Interface medium: Tape
Output method: FORTRAN unformatted write
Created by: Analytic Pressure Distribution (ACE) Program
Modified by: None
Used by: Aerodynamic Data Base Generator and ISAS
ACE display

PURPOSE OF INTERFACE

Due to various problems or time restraints, pressure coefficients for a certain flight or other conditions cannot be obtained from the wind tunnel test (SADSAC). Under these conditions, the program ACE will be used to generate the data, and this file will be output for ISAS.

CONFIGURATION CONSTRAINTS

All records shown in the format will be logical records and may contain one or more physical records. Each physical record will have the following format:

- One FORTRAN control word
- From 1 to 249 data words
- Two FORTRAN control words

ACE OUTPUT DATA FILE - Continued

FORMAT

		<u>Typ</u>	<u>Description</u>
Logical Record 1	24 data words	A	A 144 character alphanumeric title
Logical Record 2	1 data word	I	Integer number of wing panels (NWING) on one wing surface (upper or lower), maximum = 200
Logical Record 3	NWING data words	I	ID numbers of the panels (and control points) for the upper wing surface
Logical Record 4	NWING data words	I	ID numbers of the panels (and control points) for the lower wing surface
Logical Record 5	2*NWING data words	R	Percent chord location and percent span location for each control point
Logical Record 6	6*NWING data words	DP	Cartesian coordinates (X, Y, and Z) of each control point
Logical Record 7	4*NWING data words	R	Location of first control point from the root chord
		R	Location of first control point from the leading edge
			Spare
			Spare
			.
			.
			.
		R	Location of NWINGth control point from the root chord
		R	Location of NWINGth control point from the leading edge
			Spare
	Spare		
Logical Record 8	1 word	R	Mach number
	1 word	R	Angle of attack if run for wing, zero if run for tail
	1 word	K	Elevon deflection if run for wing, zero if run for tail
	1 word	R	Rudder deflection if run for tail, zero if run for wing

ORIGINAL PAGE IS
OF POOR QUALITY

ACE OUTPUT DATA FILE - Concluded

FORMAT - Concluded

	<u>Type</u>	<u>Description</u>
Logical Record 8 (conc.)	1 word	R Drag coefficient for tail or wing
	1 word	R Lift coefficient if run for wing, zero if run for tail
	1 word	R Lateral force coefficient if run for tail, zero if for wing run
	1 word	R Spare
	1 word	R Pitch moment coefficient if run for wing, zero if run for tail.
	1 word	R Yaw moment coefficient if run for tail, zero if for wing
	4 words	Spare
	1 word	R X-location reference for pitch moment if run for wing, zero if run for tail
	1 word	Spare
	1 word	Yaw moment coefficient reference X-location if run for tail, zero if run for wing
Logical Record 9	NWING words	R Pressure coefficients on each upper wing (left tail) panel
Logical Record 10	NWING words	R Pressure coefficients on each lower wing (right tail) panel
		Logical records 8 through 10 for other sets of aerodynamic conditions
	6 words	Six words containing six Fielddata 9's to indicate end-of-data

AERODYNAMIC DATA BASE

GENERAL

This file will contain the geometry information describing the standard set of grid points and pressure coefficients at each of the grid points for all the aerodynamic flight conditions tested in wind tunnels.

Type of interface: III

Interface medium: Random access mass storage

Output method: NTRAN, a UNIVAC Systems buffered input/output routine

Created by: Aerodynamic Data Base Generator

Modified by: Aerodynamic Loads, Venting Analysis, Boost Flight Conditions, Aircraft Flight Conditions, Landing Flight Conditions, Two-Body Separation, and Three-Body Separation

PURPOSE OF INTERFACE

This file will provide a central storage area for the pressure coefficients. The data stored in the file will have been validated previously and distributed over a standard model. Through the use of this file, all users will be assured of obtaining controlled quality data.

CONFIGURATION CONSTRAINTS

- Data for a maximum of four configurations can be contained in the data base at any one time.
- No configuration can have more than 15,000 sets of data in the data base at one time. However, due to mass storage requirements, the actual number should be maintained at a much lower limit.

AERODYNAMIC DATA BASE – Continued

CONFIGURATION CONSTRAINTS – Continued

- A configuration can have a maximum of 30 sections, and the same sections must be present for each set of flight conditions. (For a given flight condition, the reference data array, parameter data array, and data set creation date will apply for all sections.)
- The grid points for a given section of a configuration will be the same for each flight condition (each data set).
- The first and second dimension variable name for a given section will not change.
- The number of retrieval parameters, which will be contained on the data base, must be a minimum of 3 and a maximum of 15.
- The first three retrieval parameters must be Mach, angle of attack (α), and angle of sideslip (β), in this order. The remaining retrieval parameters will be variable
- The maximum number of unique values for each of the retrieval parameters for a configuration will be:

<u>Retrieval Parameter</u>	<u>Maximum</u>
1 (Mach)	31
2 (α)	31
3 (β)	15
4	15
5	15
6	15
7	15
8	15
9	15
10	15
11	15

AERODYNAMIC DATA BASE – Continued

CONFIGURATION CONSTRAINTS – Continued

<u>Retrieval Parameter</u>	<u>Maximum</u>
12	15
13	15
14	15
15	7

- The retrieval parameters must be the same for all configurations in the data base.
- Retrieval parameter tables will contain the unique values for each measurement. For example, if the angle of attack for two sets of data is equal to 1.5, the angle of attack for the second set (second retrieval parameter table) will contain only one value of 1.5.
- The coded index will be two 36-bit words which will be used to identify a set of data for a specific set of retrieval parameters. The words will contain pointers to the location of the real values of each of the retrieval parameters, the number of reference measurements, and the number of parameters. The format for the coded index will be:

	1	2-6	7-11	12-15	16-19	20-23	24-27	28-31	32-35	36
First word	0	Mach index	Angle of attack index	Angle of sideslip index	4th retrieval parameter index	5th retrieval parameter index	6th retrieval parameter index	7th retrieval parameter index	8th retrieval parameter index	Update
	1	2-5	6-9	10-13	14-17	18-21	22-25	26-28	29-32	33-36
Second word	0	9th retrieval parameter index	10th retrieval parameter index	11th retrieval parameter index	12th retrieval parameter index	13th retrieval parameter index	14th retrieval parameter index	15th retrieval parameter index	Number of reference measurements (NREF)	Number of parameters (NPR)

AERODYNAMIC DATA BASE - Continued

CONFIGURATION CONSTRAINTS - Continued

- When the coded index is being used to identify data for a retrieve, only bits 2 through 23 and 33 through 36 of the first word and bits 1 through 36 of the second word will be used. Bits 24 through 31 (number of reference measurements and number of parameters) of the first word will be used to determine the number of words in the Reference and Parameter Block and will be placed in the word as the data base is constructed. Bit 32 of the first word will be reserved for internal use by the Aerodynamic Data Base Generator as an update flag.
- The index reference table of the Configuration Data Block will contain the first coded index of each Block Index Record. This table will be used to determine which Block Index Record is to be read, and the starting sector number will be obtained from the sector address table.
- In order to retrieve a set of data, the following procedure will be used:
 - a. The configuration identifier and the specified values for the retrieval parameters will be obtained from the user.
 - b. The header block will be read, and the address of the required Configuration Data Block will be determined.
 - c. The Configuration Data Block will be read, the coded index will be constructed, and the address of the Block Index Record will be determined.
 - d. The Block Index Record will be read, and the address of the required Pressure Coefficient Data Block will be found.
 - e. The required Pressure Coefficient Data Block, Reference and Parameter Block, and Section Identification Block

AERODYNAMIC DATA BASE - Continued

CONFIGURATION CONSTRAINTS - Concluded

will be read. (The sector address of the Section Identification Block will be contained in the Configuration Data Block.)

- Four measurements that will be a part of the reference data array are reference area, reference chord, reference diameter, and reference length.
- All nonused words will contain a negative zero (all bits on).
- In the Block Index Records, the sector number for a specific coded index word will point to the start of the Reference and Parameter Block. The C_p data for the sections will follow immediately behind this block.
- All data blocks will start with the first word of a sector.
- When data for a configuration is to be placed in the data base, the total number of sections that will exist for that configuration must be supplied to the generating program.

AERODYNAMIC DATA BASE - Continued

FORMAT

	<u>Type</u>	<u>Description</u>							
1 Header Block	24 words	A 144 characters of any information which can be used to identify the data file							
	8 words	A	Configuration identifier for first configuration						
		I	<table border="1" style="width: 100%; border-collapse: collapse;"> <tr> <td style="width: 50%;">Sector address of first Configuration Data Block</td> <td style="width: 50%;">Number of words (NWRD) in first Configuration Data Block</td> </tr> <tr> <td style="text-align: center;">1-18</td> <td style="text-align: center;">19-36</td> </tr> <tr> <td style="text-align: center;">⋮</td> <td style="text-align: center;">⋮</td> </tr> </table>	Sector address of first Configuration Data Block	Number of words (NWRD) in first Configuration Data Block	1-18	19-36	⋮	⋮
		Sector address of first Configuration Data Block	Number of words (NWRD) in first Configuration Data Block						
		1-18	19-36						
	⋮	⋮							
	A	Configuration identifier for last configuration							
	I	<table border="1" style="width: 100%; border-collapse: collapse;"> <tr> <td style="width: 50%;">Sector address of last Configuration Data Block</td> <td style="width: 50%;">NWRD in last Configuration Data Block</td> </tr> <tr> <td style="text-align: center;">1-18</td> <td style="text-align: center;">19-36</td> </tr> </table>	Sector address of last Configuration Data Block	NWRD in last Configuration Data Block	1-18	19-36			
	Sector address of last Configuration Data Block	NWRD in last Configuration Data Block							
	1-18	19-36							
24 words		Spare							
2 sectors	1 word	I Sector address of first unused sector							
	1 word	I Number of retrieval parameters (NRET) used in this data file, minimum = 3, maximum = 15							
	2*NRET words	A	First six characters of identification of the first retrieval parameter						
		A	Second six characters of identification of the first retrieval parameter						
		⋮	⋮						
		A	First six characters of identification of retrieval parameter number NRET						
	X [†] words	A	Second six characters of identification of retrieval parameter number NRET						
			Spare						
	NWRD words		Configuration Data Block for first configuration (see format on page A-12).						

[†]The number of spare words (X) = 56 - 2 - 2*NRET.

AERODYNAMIC DATA BASE - Continued

FORMAT - Continued

	<u>Type</u>	<u>Description</u>
NBIT Blocks	504 words	First Block Index Record (see format on page A-14)
	· · ·	· · ·
	504 words	Last Block Index Record (see format on page A-14)
NSEC Blocks	MWRD words	Section Identification Block for first section of first configuration (see format on page A-15)
	· · ·	· · ·
	MWRD words	Section Identification Block for last section of first configuration (see format on page A-15)
NSEC Blocks	KWRD words	Reference and Parameter Block for first set of flight conditions (see format on page A-16)
	NPTS words	R Pressure Coefficient Data Block for first section of first configuration for first set of flight conditions (see format on page A-16)
	· · ·	· · ·
	NPTS words	R Pressure Coefficient Data Block for last section of first configuration for first set of flight conditions
	· · ·	Reference and Parameter Blocks and Pressure Coefficient Data Blocks for first configuration for remaining sets of flight conditions
	NWRD words	Configuration Data Block for second configuration (see format on page A-12)
		Block Index Records, Section Identification Blocks, Reference and Parameter Blocks, and Pressure Coefficient Data Blocks for second configuration
		Continuation of the above structure for any remaining configurations

**ORIGINAL PAGE IS
OF POOR QUALITY**

AERODYNAMIC DATA BASE - Continued

FORMAT - Continued

CONFIGURATION DATA BLOCK

	<u>Type</u>	<u>Description</u>				
20 words	A	Configuration identification				
1 word	I	Number of sections (NSEC), maximum = 30				
2*NSEC words	A	Section identifier				
	I	<table border="1"> <tr> <td>Number of words in the Section Identification Block</td> <td>Sector address of the Section Identification Block</td> </tr> <tr> <td>1-18 ⋮</td> <td>19-36 ⋮</td> </tr> </table>	Number of words in the Section Identification Block	Sector address of the Section Identification Block	1-18 ⋮	19-36 ⋮
	Number of words in the Section Identification Block	Sector address of the Section Identification Block				
	1-18 ⋮	19-36 ⋮				
A	Section identifier					
I	<table border="1"> <tr> <td>Number of words in the last Section Identification Block</td> <td>Sector address of the last Section Identification Block</td> </tr> <tr> <td>1-18</td> <td>19-36</td> </tr> </table>	Number of words in the last Section Identification Block	Sector address of the last Section Identification Block	1-18	19-36	
Number of words in the last Section Identification Block	Sector address of the last Section Identification Block					
1-18	19-36					
NRET words	I	Number of values for first retrieval parameter (NMACH), maximum = 31 ⋮				
	I	Number of values for last retrieval parameter (NRT15), maximum = 7				
1 word	I	Number of Block Index Records (NBIT), maximum = 55				
Retrieval Parameter Tables	R	Values of first retrieval parameter				
	R	Values of second retrieval parameter				
	R	Values of third retrieval parameter				

AERODYNAMIC DATA BASE - Continued

FORMAT - Continued

CONFIGURATION DATA BLOCK - Continued

	<u>Type</u>	<u>Description</u>
Retrieval Parameter Tables (conc.)	NRT4 words	R Values of fourth retrieval parameter [†]
	NRT5 words	R Values of fifth retrieval parameter [†]
	NRT6 words	R Values of sixth retrieval parameter [†]
	NRT7 words	R Values of seventh retrieval parameter [†]
	NRT8 words	R Values of eighth retrieval parameter [†]
	NRT9 words	R Values of ninth retrieval parameter [†]
	NRT10 words	R Values of 10th retrieval parameter [†]
	NRT11 words	R Values of 11th retrieval parameter [†]
	NRT12 words	R Values of 12th retrieval parameter [†]
	NRT13 words	R Values of 13th retrieval parameter [†]
	NRT14 words	R Values of 14th retrieval parameter [†]
	NRT15 words	R Values of 15th retrieval parameter [†]
	NBIT words	I Index Reference Table (see description on page A-8)

[†]The number of these tables actually in the file will be indicated by the number of retrieval parameters (NRET).

AERODYNAMIC DATA BASE - Continued

FORMAT - Continued

CONFIGURATION DATA BLOCK - Concluded

	<u>Type</u>	<u>Description</u>
NBIT words	I	Sector Address Table (contains the starting sector number of each Block Index Record)
	I	Number of grid points (NPTS) in first section
NSEC words	:	:
	I	NPTS in last section

Total number of words = 22 + NRET + 3*NSEC + 2*NBIT + NALPHA + NBETA + NRT4 + NRT5 + NRT6 + NRT7 + NRT8 + NRT9 + NRT10 + NRT11 + NRT12 + NRT13 + NRT14 + NRT15.

BLOCK INDEX RECORD

	<u>Type</u>	<u>Description</u>	
3 words	I	First word of coded index for first set of retrieval parameters (see format on page A-7)	
	I	Second word of coded index for first set of retrieval parameters (see format on page A-7)	
	I	Sector address where Pressure Coefficient Data Blocks are located	
	:	:	
	:	:	
	:	:	
	3 words	I	First word of coded index for 168th set of retrieval parameters (see format on page A-7)
		I	Second word of coded index for 168th set of retrieval parameters (see format on page A-7)
		I	Sector address where Pressure Coefficient Data Blocks are located

504 words
(18 sectors)

AERODYNAMIC DATA BASE - Continued

FORMAT - Continued

SECTION IDENTIFICATION BLOCK

<u>Type</u>	<u>Description</u>												
NPTS words	I Identification number of grid points												
3*NPTS words	R X, Y, and Z coordinates of grid points												
3*NPTS words	R Cylindrical coordinates for each grid point <table style="margin-left: auto; margin-right: auto; border-collapse: collapse;"> <tr> <td style="text-align: center; padding: 0 10px;"><u>Fuselage</u></td> <td style="text-align: center; padding: 0 10px;"><u>Wing</u></td> <td style="text-align: center; padding: 0 10px;"><u>Tail</u></td> </tr> <tr> <td style="text-align: center; padding: 0 10px;">R</td> <td style="text-align: center; padding: 0 10px;">C</td> <td style="text-align: center; padding: 0 10px;">C</td> </tr> <tr> <td style="text-align: center; padding: 0 10px;">θ</td> <td style="text-align: center; padding: 0 10px;">α_i</td> <td style="text-align: center; padding: 0 10px;">α_i</td> </tr> <tr> <td style="text-align: center; padding: 0 10px;">ϕ</td> <td style="text-align: center; padding: 0 10px;">A</td> <td style="text-align: center; padding: 0 10px;">A</td> </tr> </table>	<u>Fuselage</u>	<u>Wing</u>	<u>Tail</u>	R	C	C	θ	α_i	α_i	ϕ	A	A
<u>Fuselage</u>	<u>Wing</u>	<u>Tail</u>											
R	C	C											
θ	α_i	α_i											
ϕ	A	A											
3 words	A Section identification												
1 word	A Identification of first dimension variable												
1 word	A Identification of second dimension variable												
1 word	I Number of values (NDX) of the first dimension variable												
NDX words	I Number of values of the second dimension variable per value of the first dimension variable												
NDX words	R Values of the first dimension variable												
NPTS words	R Values of the second dimension variable												
2*NDX words	R Span and chord length for each first dimension variable. This data will be present only if the section is the tail or wing.												

Total number of words = M*RD = 4*NDX + 8*NPTS + 6

AERODYNAMIC DATA BASE - Concluded

FORMAT - Concluded

REFERENCE AND PARAMETER BLOCK

<u>Type</u>	<u>Description</u>
3 words	R Total force components for the configuration F_x , F_y , and F_z
3 words	R Total moment components for the configuration M_x , M_y , and M_z
3 words	R X, Y, and Z coordinates for totals
3*NREF words	Reference data array (REF) REF(n,1) - reference measurement name REF(n,2) - value for the reference measurement REF(n,3) - reference measurement units
2*NPR words	Parameter data array (PAR) PAR(n,1) - parameter name PAR(n,2) - parameter value
2 words	A Data set creation date
8 words	A Data set configuration name

Total number of words = KWRD = 3*NREF + 2*NPR + 19

PRESSURE COEFFICIENT DATA BLOCK

<u>Type</u>	<u>Description</u>
NPTS words	R Pressure coefficient (C_p) for each grid point

Total number of words = NPTS

ORIGINAL PAGE IS
OF POOR QUALITY

AERODYNAMIC DATA FILE

GENERAL

This temporary data file will be generated by the batch Aerodynamic Force Coefficient Program (FOCAP). The file will contain the computed incremental forces and moments at each specified load station and the integrated totals (F_x , F_y , F_z , M_x , M_y , M_z) at the aerodynamic reference joints of the configuration.

Type of interface: I
Interface medium: Random access mass storage
Output method: NTRAN
Created by: Aerodynamic Data Base Generator/FOCAP
Modified by: None
Used by: Aerodynamic Data Base Generator

PURPOSE OF INTERFACE

The display of data from this file, together with data from the C_p at Required Points File, will allow the user to determine how well the model represents the data measured in the wind tunnel. None of the data contained on this file will be carried forward to any other file.

CONFIGURATION CONSTRAINTS

The configuration constraints for this file will be the same as those described on page A-62 for the Force Coefficient Data File. However, this file can contain data for only one configuration.

AERODYNAMIC DATA FILE - Concluded

FORMAT

The format of this file will be the same as that of the Force Coefficient Data File on page A-66 with the following exceptions:

- The file will contain data for only one configuration.
- The Reference and Parameter Block will contain only the first nine words.

AERODYNAMIC INFLUENCE COEFFICIENTS FILE

GENERAL

This file will be generated by the Analytic Pressure Distribution (ACE) Program. This file will contain coefficients versus panel control points.

Type of interface: III, IV

Interface medium: TBD

Output method: TBD

Created by: ACE

Modified by: None

Used by: Static Aeroelasticity

PURPOSE OF INTERFACE

This file will be used to make pressure coefficient data available for use by the Static Aeroelasticity function.

CONFIGURATION CONSTRAINTS

The only constraints will be those existing for the file in the batch version of the ACE Program.

FORMAT

Data on this file will conform to the format specified in ACE documentation.

AEROELASTICITY DATA BASE

GENERAL

This file will be produced by the Static Aeroelasticity Correction Program (STAC) and will contain force coefficient data corrected for the effects of aeroelasticity.

Type of interface: IV
Interface medium: TBD
Output method: TBD
Created by: Static Aeroelasticity
Modified by: None
Used by: Static Aeroelasticity

PURPOSE OF INTERFACE

The file will be needed for storing corrected force coefficient data and displaying it at the terminal.

CONFIGURATION CONSTRAINTS

Constraints will be the same as those for the Force Coefficient Data File. (See page A-62).

FORMAT

The format for this file will correspond to that of the Force Coefficient Data File. In addition, this file will contain flexible-to-rigid factors for wing and vertical tail points.

AEROELASTICITY INFLUENCE COEFFICIENTS FILE

TBD

AIRCRAFT PLOT DATA FILE

GENERAL

This file will contain various parameters that can be displayed in graphical form at a remote terminal or with SC-4060 plots.

Type of interface: IV
Interface medium: TBD
Output method: TBD
Created by: Aircraft Flight Conditions
Modified by: None
Used by: Aircraft Flight Conditions

PURPOSE OF INTERFACE

This file will be used to store output parameters from the Aircraft Maneuvers Program for display at a remote terminal.

CONFIGURATION CONSTRAINTS

Data will be indexed by time.

FORMAT

The file will be determined at a later date. The file will contain the following:

- Linear and angular accelerations with respect to body axes
- Fifteen flight conditions
- Relative velocity magnitude
- Altitude
- Gimbal angle
- Thrust
- Wind velocity components

AIRCRAFT PLOT DATA FILE - Concluded

FORMAT - Concluded

- Atmospheric conditions
- Components of relative velocity
- Body velocity and acceleration
- Roll, pitch, and yaw rates
- Roll, pitch, and yaw accelerations
- Roll pitch, and yaw angles
- Roll, pitch, and yaw inertial coordinates
- Inertial velocity
- Position coordinates

BASIC DATA FILE

TBD

BASIC GEOMETRY DATA FILE

GENERAL

This permanent data file will contain a general description of the vehicle.

Type of interface: III
Interface medium: Random access mass storage
Output method: NTRAM
Created by: Basic Geometry File Generator
Modified by: None
Used by: User Model File Generator

PURPOSE OF INTERFACE

This data file will contain the functions or control points which define the surface of the vehicle and will be used by the User Model File Generator as a base upon which to construct the model.

CONFIGURATION CONSTRAINTS

There will be no constraints unless the milling machine lofting routine (FMILL) is used. When it is, there will be a maximum of 100 control points per region.

BASIC GEOMETRY DATA FILE - Continued

FORMAT

Description

ORIGINAL PAGE IS
OF POOR QUALITY

	24 words	Title	
	4 words	Spare	
	1 word	Number of structures (NST) contained on file	
2*NST words	2 words	ID of first structure	Pointer (word count) to data for first structure = word (NST + 2)
	.	36 bits	36 bits
	⋮	⋮	⋮
	.	⋮	⋮
	2 words	ID of NST th structure	Pointer (word count) to data for NST th structure
		36 bits	36 bits
	1 word	Number of substructures in the first structure (NSS ₁)	
2*NSS ₁ words	2 words	ID of first substructure in first structure	Pointer to next level of information for first substructure
	.	36 bits	36 bits
	⋮	⋮	⋮
	2 words	ID of last substructure in first structure	Pointer to next level of information for last substructure in first structure
		36 bits	36 bits
	1 word	Number of substructures in the second structure (NSS ₂)	
2*NSS ₂ words	2 words	ID of first substructure in second structure	Pointer to next level of information for first substructure of second structure
		36 bits	36 bits

FORMAT - Continued

		<u>Description</u>	
2*NSS ₂ words (conc.)	⋮	⋮	⋮
	2 words	ID of last substructure in second structure	Pointer to next level of information for last sub- structure of second structure
		36 bits	36 bits
2*NSS _N words	⋮	⋮	⋮
	2 words	ID of NSS _N th substructure in NST structure	Pointer to next level of information for last NSS _N of last NST structure
		36 bits	36 bits
NREGN + 1 words	1 word	Number of regions in substructure (NREGN)	
	1 word	Region ID of region 1	Pointer to region data (sector count)
	⋮	1-18	19-36
	⋮	⋮	⋮
	⋮	⋮	⋮
	1 word	Region ID of last region	Pointer to region data
		1-18	19-36
1 word	Number of segments in first region (NSEG ₁)		
1 word	ID of first segment in first region	Number of control points in first segment	
	1-18	19-36	

BASIC GEOMETRY DATA FILE - Continued

FORMAT - Continued

		<u>Description</u>
10 words	1 word	X-coordinate of first control point in first segment in first region
	1 word	Y-coordinate of first control point in first segment in first region
	1 word	Z-coordinate of first control point in first segment in first region
	1 word	Direction cosine with respect to X of normal to surface for first control point
	1 word	Direction cosine with respect to Y of normal to surface for first control point
	1 word	Direction cosine with respect to Z of normal to surface for first control point
	1 word	R, local radius of surface $R = [Y^2 + Z^2]^{1/2}$ for first control point
	1 word	θ , local slope of surface for first control point
	1 word	ϕ , $\tan^{-1}(Y/Z)$ for first control point
	1 word	d, bulkhead depth along normal to outer surface for first control point
10 words	1 word	X-coordinate of second control point in first segment in first region
	1 word	Y-coordinate of second control point in first segment in first region
	1 word	Z-coordinate of second control point in first segment in first region
	1 word	Direction cosine with respect to X of normal to surface for second control point

BASIC GEOMETRY DATA FILE - Continued

FORMAT - Continued

10 words (conc.)	1 word
	1 word
	1 word
	1 word
	1 word
	1 word
	:
:	
:	
1 word	
1 word	
10 words	1 word
	1 word
	1 word
	1 word
	1 word

Description

Direction cosine with respect to Y of normal to surface for second control point

Direction cosine with respect to Z of normal to surface for second control point

R, local radius of surface $R = [Y^2 + Z^2]^{1/2}$ for first control point

θ , local slope of surface for second control point

ϕ , $\tan^{-1}(Y/Z)$ for second control point

d, bulkhead depth along normal to outer surface for second control point

:
:
:

Number of segments in last NREGN region (NSEGN)

ID of first segment in last region	Number of control points in first segment
1-18	19-36

X-coordinate of first control point in first segment in last region

Y-coordinate of first control point in first segment in last region

Z-coordinate of first control point in first segment in last region

Direction cosine with respect to X of normal to surface for first control point

Direction cosine with respect to Y of normal to surface for first control point

ORIGINAL PAGE IS
OF POOR QUALITY

BASIC GEOMETRY DATA FILE - Continued

FORMAT - Continued

			<u>Description</u>				
10 words (conc.)	1 word		Direction cosine with respect to Z of normal to surface for first control point				
	1 word		R, local radius of surface for first control point of first segment in last region				
	1 word		θ , local slope of surface for first control point of first segment in last region				
	1 word		ϕ , $\tan^{-1}(Y/Z)$ for first control point of first segment in last region				
	1 word		d, bulkhead depth along normal to outer surface for first control point				
	.	.	.				
	1 word						
		<table style="width: 100%; border-collapse: collapse;"> <tr> <td style="width: 50%; padding: 2px;">ID of last segment in last region</td> <td style="width: 50%; padding: 2px;">Number of control points in last segment (NCP_N)</td> </tr> <tr> <td style="text-align: center; padding: 2px;">1-18</td> <td style="text-align: center; padding: 2px;">19-36</td> </tr> </table>	ID of last segment in last region	Number of control points in last segment (NCP_N)	1-18	19-36	
ID of last segment in last region	Number of control points in last segment (NCP_N)						
1-18	19-36						
10 words	1 word		X-coordinate of last control point in last segment in last region				
	1 word		Y-coordinate of last control point in last segment in last region				
	1 word		Z-coordinate of last control point in last segment in last region				
	1 word		Direction cosine with respect to X of normal to surface for last control point				
	1 word		Direction cosine with respect to Y of normal to surface for last control point				
	1 word		Direction cosine with respect to Z of normal to surface for last control point				
	1 word						

↓

BASIC GEOMETRY DATA FILE - Concluded

FORMAT - Concluded

Description

10 words (conc.)	}	1 word	R, local radius of surface for last control point in last segment in last region
		1 word	θ , local slope of surface for last control point in last segment in last region
		1 word	ϕ , $\tan^{-1}(Y/Z)$ for last control point in last segment in last region
		1 word	d, bulkhead depth along normal to outer surface for last control point

BASIC STRUCTURAL DIMENSIONS FILE

TBD

BASIC WEIGHT FILE

GENERAL

This file will be developed outside of ISAS for use in creating the Model Weight File.

Type of interface: I
Interface medium: TBD
Output method: TBD
Created by: Spacecraft Design Office
Modified by: None
Used by: Model Weight File Generator

PURPOSE OF INTERFACE

This file will furnish nonstructural weights of the model.

CONFIGURATION CONSTRAINTS

TBD

FORMAT

The format of this file will not be available until the ISAS Functional Specifications have been completed. The following will be contained in the file:

- Grid point number of weight location
- X, Y, and Z coordinates of the grid point
- Nonstructural weight at the grid point

BATCH FLIGHT CONDITIONS FILE

GENERAL

Flight data for one of the following stages of the vehicle will be contained in this file: boost flight, separation, aircraft flight, or landing.

Type of interface: I

Interface medium: Tape simulated mass storage

Output method: FORTRAN unformatted write

Created by: Boost Flight Program, Aircraft Maneuvers Program, Shuttle Touchdown Program, HSP2 Program, HSP3 Program, Aircraft Gust Response Program, FRISBE

Modified by: None

Used by: Flight Conditions Reformat Function (REFOR) and Batch Analysis Programs

PURPOSE OF INTERFACE

This file will be used to provide the flight conditions data to the batch analysis programs and as an input to the demand Flight Conditions Reformat (REFOR) function.

CONFIGURATION CONSTRAINTS

All records shown on the format will be logical records and may contain one or more physical records. Each physical record will have the following format:

- One FORTRAN control word
- From 1 to 249 data words
- Two FORTRAN control words

BATCH FLIGHT CONDITIONS FILE - Continued

CONFIGURATION CONSTRAINTS - Concluded

If the value for the number of engines (NENG) is equal to zero, the file will not contain a logical record 3. A zero value for the number of external forces (NEXT) will indicate that the file does not contain a logical record 4.

If the number of modes (NMODES) is equal to zero, the file will not contain mode identifications, modal accelerations, modal velocities, and modal displacements. The file will not contain any link forces or a Link Identification Block if the number of links (NLINK) is equal to zero.

BATCH FLIGHT CONDITIONS FILE - Continued

FORMAT

		<u>Type</u>	<u>Description</u>
Logical Record 1	24 words	A	Title information
	1 word	L	Logical variable (ENGID) used to identify engines; if True - use engine ID numbers False - use X, Y, and Z coordinates
Logical Record 2 (9 words)	1 word	L	Logical variable (EXTFOR) to identify external forces; if True - use ID numbers False - use X, Y, and Z coordinates
	1 word	I	Number of engines (NENG)
	1 word	I	Number of external forces (NEXT)
	1 word	I	Number of link forces (NLINK)
	1 word	I	Number of modes (NMODES)
	1 word	L	Logical variable (LNK) to identify link forces; if True - use ID numbers False - use X, Y, and Z coordinates
	1 word	R	Start time of data in seconds
Logical Record 3	1 word	R	Stop time of data in seconds
	NENG or NENG/2 words	I	If ENGID = true, this block will contain engine identification numbers (NENG words)
	NENG or NENG/2 words	R	If ENGID = false, this block will contain X, Y, and Z coordinates of engine locations (NENG/2 words), maximum size = 30 words

BATCH FLIGHT CONDITIONS FILE (continued)

2.2.5.4 continued

		<u>Type</u>	<u>Description</u>
Logical Record 4	NEXT or NEXT/2 words	I	If EXTFOR = true, this block will contain external force identification numbers (NEXT words)
		R	If EXTFOR = false, this block will contain X, Y, and Z coordinates of external forces (NEXT/2 word), maximum record size = 200 words
Logical Record 5	NMODES words	I	Identification numbers of modes, maximum record size = 100 words
Logical Record 6	NLINK or NLINK/2 words	I	If LNK = true, this block will contain link identification numbers (NLINK words)
		R	If LNK = false, this block will contain X, Y, and Z coordinates of the links (NLINK/2 words), maximum record size = 50 words
NAME Record	1 word	I	Number of Retrieval Parameters
	30 words	A	Retrieval parameter identification (two words per parameter)
Logical Record 7A (26 + NENG + NEXT words)	1 word	R	Time (seconds)
	15 word	R	Retrieval Parameters
	1 word	R	Dynamic pressure
	NENG words	R	Thrust for each engine, maximum words = 30
	NEXT words	R	Force value for each external force, maximum words = 200

ORIGINAL PAGE IS
OF POOR QUALITY

BATCH FLIGHT CONDITIONS FILE - Concluded

FORMAT - Concluded

	<u>Type</u>	<u>Description</u>
Logical Record 7A (conc.)	R	X, Y, and Z translational accelerations
	R	X, Y, and Z rigid body rotational accelerations
	R	X, Y, and Z coordinates of center of gravity
Logical Record 7B		If NLINK = 0 and NMODES = 0, there will not be a record 7B
		If NLINK = 0 and NMODES ≠ 0, record 7B will contain:
	R	Modal accelerations (NMODES words)
	R	Modal velocities (NMODES words)
	R	Modal displacements (NMODES words)
		Total number of words = 3*NMODES
		If NLINK ≠ 0 and NMODES = 0, record 7B will contain:
	R	Link forces (NLINK words)
		Total number of words = NLINK
		If NLINK ≠ 0 and NMODES ≠ 0, record 7B will contain:
R	Link forces (NLINK words)	
R	Modal accelerations (NMODES words)	
R	Modal velocities (NMODES words)	
R	Modal displacements (NMODES words)	
	Total words = NLINK + 3*NMODES	
	Logical records 7A and 7B will contain data for the remaining times	

BODY LOADS FILE

GENERAL

The Body Loads File will contain the calculated body loads force and moment components for each of the load stations and times contained on the Load Input Data File.

Type of interface: III, IV
Interface medium: Random access mass storage
Output method: NTRAN
Created by: Body Loads Analysis
Modified by: None
Used by: Body Loads Analysis

PURPOSE OF INTERFACE

All output from the body loads calculations will be stored on this file. This file will then be used to produce selected tabulations and graphical displays. It also will be used as input to the NASTRAN postprocessing function.

CONFIGURATION CONSTRAINTS

The maximum number of vehicle components (NVEHCO) will be equal to 10. The maximum number of load stations (NOLOAD) will be equal to 100.

BODY LOADS FILE - Continued

FORMAT

		<u>Description</u>
Header Block Information (56 words)	24 words	Title information
	1 word	Flag = 0, Body Loads File = 1, Modified Body Loads File
	1 word	Number of vehicle components (NVECHO)
	1 word	Number of load stations (NOLOAD)
	1 word	Number of times (NOTIME) contained on this file
	1 word	Start time
	1 word	Stop time
	26 words	Spare
Vehicle Component* ID Block (NVECHO*3 words)	3 words	Identification of first vehicle component
	.	.
	.	.
Load Station ID Block (NOLOAD*4 words)	3 words	Identification of last vehicle component
	1 word	X-coordinate of first load station
	1 word	Y-coordinate of first load station
	1 word	Z-coordinate of first load station

ORIGINAL PAGE IS
OF POOR QUALITY

BODY LOADS FILE - Continued

FORMAT - Continued

		<u>Description</u>
Load Station ID Block (NOLOAD*4 words) (conc.)	1 word	Pointer for first load station to vehicle component block identifying vehicle component for this load station
	.	.
	.	.
	.	.
Time Block (NOTIME words)	1 word	X-coordinate of last load station
	1 word	Y-coordinate of last load station
	1 word	Z-coordinate of last load station
	1 word	Pointer for last load station to vehicle component block identifying vehicle component for this load station
	1 word	First time
Body loads force and moment com- ponents for first time and first load station (38 words)	.	
	.	
	.	
	1 word	Last time
	6 words	Rigid body loads: force components in X, Y, and Z directions, moment components in X, Y, and Z directions
6 words	Elastic body loads: force components in X, Y, and Z directions, moment components in X, Y, and Z directions	
6 words	Engine and external force loads: force components in X, Y, and Z directions, moment components in X, Y, and Z directions	
6 words	Aerodynamic loads: force components in X, Y, and Z directions, moment components in X, Y, and Z directions	

ORIGINAL PAGE 12
OF 1000 QUALITY

BODY LOADS FILE - Continued

FORMAT - Continued

		<u>Description</u>
	6 words	Link loads: force components in X, Y, and Z directions, moment components in X, Y, and Z directions
Body loads force and moment components for first time and first load station (38 words) (conc.)	6 words	Total loads: force components in X, Y, and Z directions, moment components in X, Y, and Z directions
	1 word	Root summed square force
	1 word	Root summed square moment
	38 words	
Body loads force and moment components for first time and second load station	.	
	.	
	.	
Body loads force and moment components for first time and last load station	38 words	
Body loads force and moment components for second time and first load station	38 words	
	.	
	.	
Body loads force and moment components for second time and last load station	38 words	
	.	
	.	
	.	

BODY LOADS FILE - Concluded

FORMAT - Concluded

Description

Body loads force
and moment com-
ponents for last
time and first
load station

38 words
· · ·

Body loads force
and moment com-
ponents for last
time and last
load station

ORIGINAL PAGE IS
OF POOR QUALITY

BOOST AND AIRCRAFT FLIGHT CONDITIONS FILE

This file was replaced by the Batch Flight Conditions File.

BOOST PLOT DATA FILE

GENERAL

This file will contain various parameters that can be displayed in graphical form at a remote terminal or with SC-4060 plots.

Type of interface: IV
Interface medium: TBD
Output method: TBD
Created by: Boost Flight Conditions
Modified by: None
Used by: Boost Flight Conditions

PURPOSE OF INTERFACE

This file will be used to store output parameters from the Boost Flight Program for display at a remote terminal.

CONFIGURATION CONSTRAINTS

Data will be indexed by time.

FORMAT

The file format will be determined at a later date. The file will contain time; 15 flight conditions; weight; linear and rotational body accelerations; Euler angles and comma Euler angles; wind velocity components; total thrust; altitude; length of thrust moment arms; relative velocity; fittings loads and vertical reactions; and thrust, pitch gimbal command, and yaw gimbal command for engines 1 to 5.

COMBINED DATA FILE

GENERAL

This temporary file will contain modal data from the User Modal tape and force data from the Force Coefficient Data File. It will be created if the user wishes to execute the Adjusted Aerodynamics Program.

Type of interface: IV

Interface medium: TBD

Output method: TBD

Created by: Aircraft Gust and Boost Turbulence Loads

Modified by: None

Used by: Aircraft Gust and Boost Turbulence Loads

PURPOSE OF INTERFACE

This file will be used as input to the batch Adjusted Aerodynamics Program. It will contain the modal and force data required by that program.

CONFIGURATION CONSTRAINTS

TBD

FORMAT

TBD

COMPRESSED AERODYNAMIC FORCES AND CONDITIONS FILE

GENERAL

This file will contain data for selected times from the ISAS Flight Conditions File. It will also contain aerodynamic force and moment coefficients from the Force Coefficient Data File for the flight conditions at the selected times.

Type of interface: IV
Interface medium: Random access mass storage
Output method: NTRAN
Created by: Body Loads Analysis
Modified by: None
Used by: Body Loads Analysis

PURPOSE OF INTERFACE

This file will contain all flight data and aerodynamic force and moment coefficient data for each time point needed by the user to perform his body loads analysis.

CONFIGURATION CONSTRAINTS

- If the value for the number of engines (NENG) is equal to zero, this file will not contain an Engine Identification Block or engine thrust data.
- If the number of external forces (NEXT) is equal to zero, this file will not contain an External Force Identification Block or any external force data.
- If the number of modes (NMCDES) is equal to zero, this file will not contain a Mode Identification Block or any modal accelerations, modal velocities, or modal displacements.

COMPRESSED AERODYNAMIC FORCES AND CONDITIONS FILE – Continued

CONFIGURATION CONSTRAINTS – Concluded

- If the number of links (NLINK) is equal to zero, this file will not contain a Link Identification Block or any link forces.

COMPRESSED AERODYNAMIC FORCES AND CONDITIONS FILE - Continued

FORMAT

Description

Header Information Block (56 words)	24 words	Title information
	1 word	Logical variable (ENGID) to identify engines; if True - use engine ID numbers False - use X, Y, and Z coordinates
	1 word	Logical variable (EXTFOR) to identify external forces; if True - use ID numbers False - use X, Y, and Z coordinates
	1 word	Logical variable (LNK) to identify link forces; if True - use ID numbers False - use X, Y, and Z coordinates
	1 word	Number of engines (NENG), maximum = 30
	1 word	Number of external forces (NEXT), maximum = 200
	1 word	Number of link forces (NLINK), maximum = 50
	1 word	Number of modes (NMODES), maximum = 200
	1 word	Start time for data contained on this file
	1 word	Stop time for data contained on this file
	1 word	Number of times (NOTIME) contained on this file
	1 word	Number of grid points in loads model (NOGP), maximum = 400
	1 word	Beginning word location of data blocks

ORIGINAL PAGE IS
OF POOR QUALITY

COMPRESSED AERODYNAMIC FORCES AND CONDITIONS FILE - Continued

FORMAT - Continued

		<u>Description</u>
Header Information Block (conc.)	1 word	Number of words per data block
	1 word	0 - link forces of Flight Conditions File are used 1 - link forces are to be computed
	18 words	Spare
Engine ID Block	NENG or (NENG/6)3	Logical variable (ENGID) to identify engines; if True - use engine ID numbers (NENG words) False - use X, Y, and Z coordinates (NENG/2 words)
External Force ID Block	NEXT or (NEXT/6)3	Logical variable (EXTFOR) to identify external forces; if True - use ID numbers (NEXT words) False - use X, Y, and Z coordinates (NEXT/2 words)
Mode ID Block	NMODES	Identification numbers for each of the modes
Link ID Block	NLINK or (NLINK/6)3	Logical variable (LNK) to identify link forces; if True - use ID numbers (NLINK words) False - use X, Y, and Z coordinates (NLINK/2 words)
Point ID Block	NOGP	Load model grid point identification numbers
Point Coordinate Block	NOGP*3	X, Y, and Z coordinates of each point
Data Block for first time	1 word	Time
	15 words	15 flight retrieval parameters

COMPRESSED AERODYNAMIC FORCES AND CONDITIONS FILE - Continued

FORMAT - Continued

	<u>Description</u>
3 words	X, Y, and Z coordinates of center of gravity
3 words	X, Y, and Z directions translational rigid body acceleration
3 words	X, Y, and Z directions rotational rigid body acceleration
NENG	Thrust for engine number 1 : : : Thrust for engine number NENG
NEXT	Force for external force number 1 : : : Force for external force number NEXT
NMODES	Modal acceleration for first mode : : : Modal acceleration for last mode
NMODES	Modal velocity for first mode : : : Modal velocity for last mode
NMODES	Modal displacement for first mode : : : Modal displacement for last mode

Data Block for
first time
(27 + NENG +
NEXT + NLINK
+ 3*NMODES +
6*NOGP words)

ORIGINAL PAGE IS
OF POOR QUALITY

COMPRESSED AERODYNAMIC FORCES AND CONDITIONS FILE - Concluded

FORMAT - Concluded

		<u>Description</u>	
Data Block for first time (27 * NENG * NEXT * NLINK * 3*NMODES + 6*NOGP words) (conc.)	NLINK	Force for first link : :	
	3 words	Force for last link	
	3 words	X, Y, and Z aerodynamic force coefficient components for first aerodynamic force station	
	3 words	X, Y, and Z aerodynamic moment coefficient components for first aerodynamic force station	
	:	:	
	:	:	
	3 words	X, Y, and Z aerodynamic force coefficient components for last aerodynamic force station	
	3 words	X, Y, and Z aerodynamic moment coefficient components for last aerodynamic force station	
	Data Block for second time		
		:	:
Data Block for last time			
Time Block		Time for first data block on this file : :	
	NOTIME	Time for last data block on this file	

C_p AT REQUIRED POINTS FILE

GENERAL

This data file will contain pressure coefficient (C_p) data for the set of grid points required by the individual user. Also contained in the file will be the geometry information which describes the grid points.

Type of interface: II, III

Interface medium: Random access mass storage

Output method: NTRAN

Created by: Aerodynamic Loads, Aerodynamic Data Base Generator

Modified by: None

Used by: Force Inputs to Internal Loads Analysis, Static Aeroelasticity/FOCAP, Aerodynamic Data Base Generator/FOCAP, Venting Analysis/VADIC, Aerodynamic Loads/FOCAP

PURPOSE OF INTERFACE

This file will be used to provide pressure coefficient data and geometry data for the specified values of the retrieval parameters and grid points to other ISAS functions.

CONFIGURATION CONSTRAINTS

The configuration constraints for this file will be the same as for the Aerodynamic Data Base but with one exception. This file will contain data for only one configuration.

FORMAT

The format and description of this file will be identical to the one described on page A-5 for the Aerodynamic Data Base.

ELEMENT PROPERTY FILE

GENERAL

This file will contain finite element properties of the user model.

Type of interface: III

Interface medium: TBD

Output method: TBD

Created by: Element Property File Generator

Modified by: None

Used by: Model Weight File Generator, Internal Loads and Dynamic Characteristics, Properties and Allowables

PURPOSE OF INTERFACE

This file will be used to supply element properties to NASTRAN.

CONFIGURATION CONSTRAINTS

None exist at this time.

FORMAT

Data on the file should include finite element properties at each model point.

EXTERNAL PRESSURE FILE

GENERAL

This file will contain element geometry information and either differential pressure or external pressure. The type of pressure data contained will be dependent upon user decision. This file will be temporary and should be resident for short periods of time.

Type of interface: III, IV

Interface medium: Tape or sequential mass storage

Output method: NTRAN

Created by: Force Inputs to Internal Loads Analysis

Modified by: None

Used by: Force Inputs to Internal Loads Analysis

PURPOSE OF INTERFACE

This file will be used to provide easy accessibility to data which is to be tabulated, plotted, or formatted into PLOAD2 cards.

CONFIGURATION CONSTRAINTS

Data for only one vehicle configuration can be contained in the file, and the configuration can have a maximum of 30 sections.

EXTERNAL PRESSURE FILE - Continued

FORMAT

	<u>Type</u>	<u>Description</u>
Header Block (28 words)	A	File identification
	I	Number of elements (NELEM), maximum = 6000
	I	Number of timepoints (NTIME)
		Configuration ID
	I	Number of sections in this configuration
Subheader Block (200 words)	I	Sector address of elements in first section
	I	Word address of elements in first section
	I	Number of elements in this section
	A	Section ID
	I	Number of elements selected for each element type 1-15
	A	Spare
		Repeat for each section
	A	Spare

Total number of words = 280

EXTERNAL PRESSURE FILE - Concluded

FORMAT - Concluded

	<u>Type</u>	<u>Description</u>	
Geometry Block (560 words)	I	1 word First element identification number	
	R	9 words X, Y, and Z coordinates of center point of first element and ϕ Number of connections Connection specifications	
		.	.
		.	.
	I	1 word 56th element identification	
Pressure Block [†]	R	9 words X, Y, and Z coordinates of center point of 56th element and ϕ Number of connections Connection specifications each connection	
		.	Geometry blocks containing identification numbers and coordinates of remaining elements
	R	1 word First time (seconds)	
	R	15 words 15 flight conditions	
	R	NELEM words Differential or external pressure at each element	
		.	Pressure Blocks for remaining time points

[†]Written out in 560-word buffers.

ORIGINAL PAGE IS
OF POOR QUALITY

FATIGUE INPUT DATA FILE

TBD

FATIGUE OUTPUT DATA FILE

TBD

FATIGUE SPECTRAL DATA FILE

TBD

C. 6

FEEDLINE MODAL DATA FILE

TBD

FORCE COEFFICIENT DATA FILE

GENERAL

This permanent data file will contain incremental forces and moment coefficients at specified grid points and the integrated totals (F_x , F_y , F_z , M_x , M_y , M_z). Data for multiple sets of flight conditions and for four different configurations will be contained on the same file.

Type of interface: I, III
Interface medium: Random access mass storage
Output method: NTRAN
Created by: Aerodynamic Loads
Modified by: None
Used by: Static Aeroelasticity, Aircraft Gust and Boost
Turbulence Loads, Body Loads Analysis, Force
Inputs to Internal Loads Analysis, FRISBE

PURPOSE OF INTERFACE

This file will be used as a common source within ISAS for force coefficient data.

CONFIGURATION CONSTRAINTS

- Data for a maximum of four configurations can be contained in this file at any one time.
- No configuration can have more than 15,000 sets of data in the data base at one time. However, due to mass storage requirements, the actual number should be maintained at a much lower limit.
- The grid points describing the configuration will be the same for each set of flight conditions (each data set).

FORCE COEFFICIENT DATA FILE - Continued

CONFIGURATION CONSTRAINTS - Continued

- A configuration can have a maximum of 30 sections, and the same sections must be present for each set of reference conditions.
- The reference data array, parameter data array, and data set creation data will apply for all sections for a given set of values for the retrieval parameters.
- The number of retrieval parameters, which will be contained on the data base, will be a minimum of 3 and a maximum of 15.
- The maximum number of unique values for each of the retrieval parameters for a configuration will be:

<u>Retrieval Parameter</u>	<u>Maximum</u>
1 (Mach)	31
2 (α)	31
3 (β)	15
4	15
5	15
6	15
7	15
8	15
9	15
10	15
11	15
12	15
13	15
14	15
15	7

FORCE COEFFICIENT DATA FILE – Continued

CONFIGURATION CONSTRAINTS – Continued

- The first three retrieval parameters must be Mach, angle of attack (α), and angle of sideslip (β), in this order. The remaining retrieval parameters will be variable.
- The retrieval parameter tables will contain the unique values for each measurement. For example, if the angle of attack in two data sets is equal to 1.5, the Angle of Attack Table (second retrieval parameter table) will contain only one value of 1.5.
- The coded index will be two 36-bit words which will be used to identify a set of data for a specific set of retrieval parameters. The words will contain pointers to the location of the real values of each of the retrieval parameters, the number of reference measurements, and the number of parameters. The format for the coded index will be:

	1	2-6	7-11	12-15	16-19	20-23	24-27	28-31	32-35	36
First word	0	Mach index	Angle of attack index	Angle of sideslip index	4th retrieval parameter index	5th retrieval parameter index	6th retrieval parameter index	7th retrieval parameter index	8th retrieval parameter index	Update

	1	2-5	6-9	10-13	14-17	18-21	22-25	26-28	29-32	33-36
Second word	0	9th retrieval parameter index	10th retrieval parameter index	11th retrieval parameter index	12th retrieval parameter index	13th retrieval parameter index	14th retrieval parameter index	15th retrieval parameter index	Number of reference measurements (NREF)	Number of parameters (NPR)

- When the coded index is being used to identify data for a retrieve, only bits 2 through 35 of the first word and bits 2 through 28 of the second word will be used. Bits 29

FORCE COEFFICIENT DATA FILE - Continued

CONFIGURATION CONSTRAINTS - Concluded

through 36 (number of reference measurements and number of parameters) of the second word will be used to determine the number of words in the Reference and Parameter Block and will be placed in the word as the data base is constructed. Bit 36 of the first word will be reserved for internal use by the Aerodynamic Data Base Generator as an update flag.

- The index reference table of the Configuration Data Block will contain the first coded index of each Block Index Record. This table will be used to determine which Block Index Record is to be read, and the starting sector number will be obtained from the sector address table.
- All data blocks will start with the first word of a sector.

FORCE COEFFICIENT DATA FILE - Continued

FORMAT

		<u>Type</u>	<u>Description</u>	
2 sectors	24 words	A	144 characters of any information which can be used to identify the file	
	8 words	A	Configuration identifier of first configuration	
		I	Sector address of first Configuration Data Block	Number of words (NWRD) in Configuration Data Block
			1-18	19-36
		:	:	:
	:	:	:	
	A	Configuration identifier of fourth configuration		
	I	Sector address of fourth Configuration Data Block	NWRD in fourth Configuration Data Block	
		1-18	19-36	
	24 words		Spare	
1 word		Spare		
1 word	I	Number of retrieval parameters (NRET) used in this data file, minimum = 3, maximum = 15		
2*NRET words	A	First six characters of identification of the first retrieval parameter		
	A	Second six characters of identification of the first retrieval parameter		
	:	:		
	:	:		
	A	First six characters of identification of retrieval parameter number NRET		
	A	Second six characters of identification of retrieval parameter number NRET		
X [†] words		Spare		

[†]The number of spare words (X) = 56 - 2 - 2*NRET

FORCE COEFFICIENT DATA FILE - Continued

FORMAT - Continued

		<u>Type</u>	<u>Description</u>
NBIT Blocks	NWRD words		First Configuration Data Block
	560 words		First Block Index Record
	· · ·		· · ·
	560 words		Last Block Index Record
	MWRD words		Geometry Data Block
	KWRD words		Reference and Parameter Block
	IWRD words		Incremental Data Block for first set of flight conditions for first configuration
	· · ·		Incremental Data Blocks for remaining sets of flight conditions for first configuration
			Configuration Data Blocks, Block Index Records, Geometry Data Blocks, Reference and Parameter Blocks, and Incremental Data Blocks for remaining configurations

CONFIGURATION DATA BLOCK

	<u>Type</u>	<u>Description</u>
20 words	A	Configuration identification
1 word	I	Integer value of 1
1 word	A	Section identifier = ADBFCD

ORIGINAL PAGE IS
OF POOR QUALITY

FORCE COEFFICIENT DATA FILE - Continued

FORMAT - Continued

CONFIGURATION DATA BLOCK - Continued

	<u>Type</u>	<u>Description</u>				
1 word	I	<table border="1"> <tr> <td>Number of words in Geometry Data Block (MWRD)</td> <td>Sector address of Geometry Data Block</td> </tr> <tr> <td>1-18</td> <td>19-36</td> </tr> </table>	Number of words in Geometry Data Block (MWRD)	Sector address of Geometry Data Block	1-18	19-36
Number of words in Geometry Data Block (MWRD)	Sector address of Geometry Data Block					
1-18	19-36					
NRET words	I	Number of values for first retrieval parameter, Mach (NMACH), maximum = 31 :				
	I	Number of values for last retrieval parameter, (NRT15), maximum = 7				
1 word	I	Number of Block Index Records (NBIT), maximum = 55				
NMACH words	R	Values of first retrieval parameter				
NALPHA words	R	Values of second retrieval parameter				
NBETA words	R	Values of third retrieval parameter				
NRT4 words	R	Values of fourth retrieval parameter				
NRT5 words	R	Values of fifth retrieval parameter				
NRT6 words	R	Values of sixth retrieval parameter				
NRT7 words	R	Values of seventh retrieval parameter				
NRT8 words	R	Values of eighth retrieval parameter				
NRT9 words	R	Values of ninth retrieval parameter				
NRT10 words	R	Values of 10th retrieval parameter				

FORCE COEFFICIENT DATA FILE - Continued

FORMAT - Continued

CONFIGURATION DATA BLOCK - Concluded

	<u>Type</u>	<u>Description</u>
NRT11 words	R	Values of 11th retrieval parameter
NRT12 words	R	Values of 12th retrieval parameter
NRT13 words	R	Values of 13th retrieval parameter
NRT14 words	R	Values of 14th retrieval parameter
NRT15 words	R	Values of 15th retrieval parameter

BLOCK INDEX RECORD

	<u>Type</u>	<u>Description</u>
3 words		First word of coded index for first set of retrieval parameters
		Second word of coded index for first set of retrieval parameters
		Sector address where Force Data Block is located
504 words		:
		:
		:
3 words		First word of coded index for 168th set of retrieval parameters
		Second word of coded index for 168th set of retrieval parameters
		Sector address where Force Data Block is located

FORCE COEFFICIENT DATA FILE - Continued

FORMAT - Continued

GEOMETRY DATA BLOCK

	<u>Type</u>	<u>Description</u>
NPTS words	I	Identification numbers of points
3*NPTS words	R	X, Y, and Z coordinates for each point
NPTS words	A	Section identifier for each plot

Total number of words = MWRD = 5*NPTS

REFERENCE AND PARAMETER BLOCK

	<u>Type</u>	<u>Description</u>
3 words	R	Total force components for the configuration F_x , F_y , and F_z
3 words	R	Total moment components for the configuration M_x , M_y , and M_z
3 words	R	X, Y, and Z coordinates for totals
3*NREF words		Reference data array (REF) REF(n,1) - reference measurement name REF(n,2) - value for the reference measurement REF(n,3) - reference measurement units
2*NPR words		Parameter data array (PAR) PAR(n,1) - parameter name PAR(n,2) - parameter value
2 words	A	Data set creation date
8 words	A	Data set configuration name

Total number of words = KWRD = 3*NREF + 2*NPR + 19

FORCE COEFFICIENT DATA FILE - Concluded

FORMAT - Concluded

INCREMENTAL DATA BLOCK

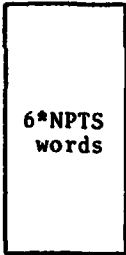
	<u>Type</u>	<u>Description</u>
		Incremental data array (FDA)
		FDA(n,1) = X-force component F_x
		FDA(n,2) = Y-force component F_y
	R	FDA(n,3) = Z-force component F_z
		FDA(n,4) = X-moment component M_x
		FDA(n,5) = Y-moment component M_y
		FDA(n,6) = Z-moment component M_z

Total number of words = IWRD = 6*NPTS

ORIGINAL PAGE IS
OF POOR QUALITY

FORCE COEFFICIENT FILE

GENERAL

The Force Coefficient File will be a temporary data file which will be generated by the batch program FCCAP. The file will contain the computed incremental forces and moment coefficients at each specified grid point and the integrated totals (F_x , F_y , F_z , M_x , M_y , M_z) at the aerodynamic reference points.

Type of interface: I
Interface medium: Random access mass storage
Output method: NTRAN
Created by: Aerodynamic Loads/FOCAP
Modified by: None
Used by: Aerodynamic Loads

PURPOSE OF INTERFACE

This file will be used to provide increment forces and moments for specified grid points and totals to the Aerodynamic Loads function and for later use by other ISAS functions.

CONFIGURATION CONSTRAINTS

The configuration constraints for this file will be the same as those described on page A-62 for the Force Coefficient Data File. However, this file can contain data for only one configuration.

FORCE COEFFICIENT FILE - Concluded

FORMAT

The format of this file will be the same as that of the Force Coefficient Data File on page A-66 with the following exceptions:

- It will contain data for only one configuration.
- The Reference and Parameter Block will contain only the first nine words.

GUST INPUT FILE

GENERAL

The Gust Input File will be a temporary file created in the Aircraft Gust and Boost Turbulence Loads function. It will contain data selected from the following four files: Basic Data File, Unsteady Aerodynamic Generalized Forces File, Load Coefficient Data File, Standard Atmosphere File.

Type of interface: IV

Interface medium: TBD

Output method: TBD

Created by: Aircraft Gust and Boost Turbulence Loads

Modified by: None

Used by: Aircraft Gust and Boost Turbulence Loads

PURPOSE OF INTERFACE

This file will be used as input to the Gust Response and Turbulence Response Programs. It will contain all necessary input for these programs.

CONFIGURATION CONSTRAINTS

TBD

FORMAT

TBD

INPUT FLIGHT CONDITIONS FILE

TBD

INTERIM AERODYNAMIC DATA FILE

GENERAL

This temporary data file will contain pressure coefficients (C_p) and geometry data for the standard set of grid points for specified flight conditions.

Type of interface: IV
Interface medium: Random access mass storage
Output method: NTRAN
Created by: Aerodynamic Loads
Modified by: None
Used by: Aerodynamic Loads

PURPOSE OF INTERFACE

This file will be used as temporary storage for data which has been developed from the Aerodynamic Data Base and is to be used to determine pressure coefficients for a new model.

CONFIGURATION CONSTRAINTS

With the exception that data for only one configuration will be contained on this file, the configuration constraints will be the same as for the Aerodynamic Data Base described on page A-5.

FORMAT

The format of this file will be identical to that of the Aerodynamic Data Base (page A-5), except that data for only one configuration will be contained on the file.

INTERIM PROPERTIES AND ALLOWABLES FILE

GENERAL

This file will contain the collected material and geometric properties for each section of a vehicle model.

Type of interface: IV
Interface medium: TBD
Output method: TBD
Created by: Properties and Allowables
Modified by: None
Used by: Properties and Allowables

PURPOSE OF INTERFACE

This file will be used by the Properties and Allowables function as a central storage area for all of the input required to calculate allowables.

CONFIGURATION CONSTRAINTS

Data for only one structure can be placed on the file. The structure can have a maximum of 30 regions (substructures).

FORMAT

The actual format of the file will not be developed until the functional design specifications are completed. The information listed below will be contained in the file for each station of each region.

- Section identification number
- Section type identification
- X, Y, and Z coordinates of station

INTERIM PROPERTIES AND ALLOWABLES FILE – Concluded

FORMAT – Concluded

- Geometry parameters (b, t, R, ϕ)
- Material compressive modulus (E)
- Material tensile ultimate stress (FTU)
- Poisson's ratio (μ)
- Material compressive yield stress (FC)
- Material shear stress (FS)
- Material secant modulus (E_s)
- Material tangent modulus (E_t)
- Curve shape factor (η)
- Curve secant yield stress ($F_{0.7}$)

INTERIM SADSAC DATA FILE

GENERAL

The Interim SADSAC Data File will contain pressure coefficients (C_p) and geometry data for pressure tabulations. This data will be obtained from System for Automatic Development of Static Aerothermodynamic Criteria (SADSAC) tapes which are created during wind tunnel tests.

Type of interface: I
Interface medium: Random access mass storage
Output method: NTRAN
Created by: SADSAC Reformat Program
Modified by: None
Used by: Aerodynamic Data Base Generator

PURPOSE OF INTERFACE

This data file will be used to provide data from the SADSAC tapes to ISAS. The SADSAC data will have been verified and minor corrections completed before the new data file is created.

CONFIGURATION CONSTRAINTS

With the exception that data for only one configuration will be contained on this file, the constraints will be the same as for the Aerodynamic Data Base described on page A-5.

FORMAT

Except for the constraint described above, the format will be the same as for the Aerodynamic Data Base (see page A-5).

INTERMEDIATE MODEL WEIGHT FILE

GENERAL

This temporary data file will contain interpolated weights for grid points of the model. The file will be created by the Model Weight File Generator.

Type of interface: IV

Interface media: TBD

Output method: TBD

Created by: Model Weight File Generator

Modified by: Model Weight File Generator

Used by: Model Weight File Generator

PURPOSE OF INTERFACE

This file will be created as an interim file in the process of developing the Model Weight File. The file will provide temporary storage and allow for safe-points.

CONFIGURATION CONSTRAINTS

TBD

FORMAT

This interim file should include the following information:

- Grid point identification numbers
- X, Y, and Z coordinates of grid points
- Interpolated weights (6 × 1 vector for each grid point)

INTERPOLATED CONTROL POINT FILE

GENERAL

This data file will be used exclusively in the Lifting Surface Flutter/Unsteady Aerodynamic Forces function. It will contain modal frequency and interpolated modal displacement data.

Type of interface: IV

Interface medium: Random access mass storage

Output method: NTRAN

Created by Lifting Surface Flutter/Unsteady Aerodynamic Forces

Modified by: None

Used by: Lifting Surface Flutter/Unsteady Aerodynamic Forces

PURPOSE OF INTERFACE

This file will be used as a storage for the modal displacement data which has been interpolated to the aerodynamic control points. Data will be selected from this file to form the Unsteady Aerodynamic Input File.

CONFIGURATION CONSTRAINTS

TBD

FORMAT

The format of this file will be determined during the functional design stage; however, it will contain the following information.

- Title information
- Number of grid points

INTERPOLATED CONTROL POINT FILE - Concluded

FORMAT - Concluded

- Grid point ID numbers and grid point coordinates
- Number of modes
- Modal frequencies
- Interpolated modal displacement data

INTERPOLATED STRUCTURAL DATA FILE

GENERAL

This file will contain structural data interpolated to aerodynamic grid points.

Type of interface: I
Interface medium: TBD
Output method: TBD
Created by: Static Aeroelasticity
Modified by: None
Used by: Static Aeroelasticity

PURPOSE OF INTERFACE

This file will allow the user to store the interpolated structural data and examine it at the console. The data will subsequently be used to form an input file for the Static Aeroelasticity Program.

CONFIGURATION CONSTRAINTS

A maximum of 1000 grid locations will exist. A matrix will be limited to 100 × 100.

FORMAT

The file format will be determined in the functional specifications phase. A file will contain grid locations, control point numbers, and an interpolated influence coefficient matrix.

ISAS FLIGHT CONDITIONS FILE

GENERAL

Flight data for one of the following stages of the vehicle will be contained in this file: boost flight, separation, aircraft flight, or landing.

Type of interface: III
Interface medium: Random access mass storage
Output method: NTRAN
Created by: Flight Conditions Reformat function (REFOR)
Modified by: None
Used by: Force Inputs to Internal Loads Analysis, Body Loads Analysis, Flight Conditions Merge, Flight Conditions File Reduction

PURPOSE OF INTERFACE

This file will be used to transmit the flight data to the analysis programs.

CONFIGURATION CONSTRAINTS

- If the value for the number of engines (NENG) is equal to zero, the file will not contain an Engine Identification Block or engine thrust data.
- A zero value for the number of external forces (NEXT) will indicate that the file does not contain an External Force Identification Block or any external force values.
- If the number of modes (NMODES) is equal to zero, the file will not contain a Mode Identification Block or any modal accelerations, modal velocities, or modal displacements.
- The file will not contain any link forces or a Link Identification Block if the number of links (NLINK) is equal to zero.

ISAS FLIGHT CONDITIONS FILE - Continued

FORMAT

		<u>Description</u>
Header Information Block (56 words)	24 words	Title information
	1 word	Logical variable (ENGID) to identify engines; if True - use engine ID numbers; False - use X, Y, and Z coordinates
	1 word	Logical variable (EXTFOR) to identify external forces; if True - use ID numbers False - use X, Y, and Z coordinates
	1 word	Logical variable (LNK) to identify link forces; if True - use ID numbers False - use X, Y, and Z coordinates
	1 word	Number of engines (NENG)
	1 word	Number of external forces (NEXT)
	1 word	Number of link forces (NLINK)
	1 word	Number of modes (NMODES)
	1 word	Start time for data contained on this file (floating point seconds)
	1 word	Stop time for data contained on this file (floating point seconds)
	1 word	Increment between times = TINC [†] (floating point seconds)

[†]Time increment (TINC) will be equal to zero if the data points are not for a regular time increment.

ORIGINAL PAGE IS
OF POOR QUALITY

ISAS FLIGHT CONDITIONS FILE - Continued

FORMAT - Continued

		<u>Description</u>
Header Information Block (cont.)	1 word	Demand FLAG = 'ISAS^^'
	1 word	Number of times (NIME) Equal to zero if time increment is regular
	1 word	Starting sector number of first time block
	19 words	Spare
Engine ID Block	NENG or (NENG/2)	Logical variable (ENGID) to identify engines; if True - use ID numbers (NENG words) False - use X, Y, and Z coordinates (NENG/2 words) Maximum size = 30 words
External Force ID Block	NEXT or (NEXT/2)	Logical variable (EXTFOR) to identify external forces; if True - use ID numbers (NEXT words) False - use X, Y, and Z coordinates (NEXT/2 words) Maximum size = 200 words
Mode ID Block	NMODES	If NMODES = 0, no entry If NMODES > 0, identification of each of the modes will be entered here Maximum size = 200 words
Link ID Block	NLINK or (NLINK/2)	If LNK = 0, no entry Logical variable (LNK) to identify link forces; if True - use ID numbers (NLINK words) False - use X, Y, and Z coordinates (NLINK/2 words) Maximum size = 50 words
Data Block for first time [†] (27 + NENG + NEXT + NLINK + 3*NMODES words)	1 word	Time (floating point seconds)
	15 words	15 retrieval parameters

[†]Number of words per data block = 16 + NENG + NEXT + NLINK + 3*NMODES + TWRD

ISAS FLIGHT CONDITIONS FILE - Continued

FORMAT - Continued

Description

Data Block
for first time[†]
(cont.)
(27 + NENG +
NEXT + NLINK +
3*NMODES words)

NENG words	Thrust for each engine in order 1 through NENG (real number)
NEXT words	Force value for each external force in numerical order (real number)
1 word	
1 word	X, Y, and Z translational accelerations
1 word	
1 word	X-direction rigid body rotational acceleration (real number)
1 word	Y-direction rigid body rotational acceleration (real number)
1 word	Z-direction rigid body rotational acceleration (real number)
1 word	X-coordinate of center of gravity (real number)
1 word	Y-coordinate of center of gravity (real number)
1 word	Z-coordinate of center of gravity (real number)

[†]Number of words per data block = 16 + NENG + NEXT + NLINK + 3*NMODES = TWRD

ORIGINAL PAGE IS
OF POOR QUALITY

ISAS FLIGHT CONDITIONS FILE - Concluded

FORMAT - Concluded

			<u>Description</u>
Data Block for first time [†] (conc.)	}	NLINK words	Force value for each link in numerical order (real number). If NLINK is equal to zero, this block will not be on file
		NMODES words	Modal acceleration for each mode in numerical order (real number)
		NMODES words	Modal velocities for each mode in numerical order (real number)
		NMODES words	Modal displacements for each mode (real number)
Data Block for second time		TWRD	
		.	.
		.	.
Data Block for last time		TWRD words	
		280 words	} The number of time blocks is equal to the number of times (NTIME) divided by 280. If the time increment is regular (TINC ≠ 0), there will not be any time blocks
		.	
		.	
		280 words	

[†]Number of words per data block = 16 + NENG + NEXT + NLINK + 3*NMODES = TWRD

LIFTING SURFACE FLUTTER INPUT FILE

GENERAL

This file will be used exclusively in the Lifting Surface Flutter/Unsteady Aerodynamic Forces function and will contain mass data, stiffness data, and unsteady generalized forces data.

Type of interface: IV

Interface medium: Random access mass storage

Output method: NTRAN

Created by: Lifting Surface Flutter/Unsteady Aerodynamic Forces

Modified by: None

Used by: Lifting Surface Flutter/Unsteady Aerodynamic Forces

PURPOSE OF INTERFACE

This file will contain all the data needed by the batch Flutter Solution Program.

CONFIGURATION CONSTRAINTS

TBD

FORMAT

The format of this file will be determined during the functional design stage.

LIFTING SURFACE FLUTTER OUTPUT FILE

GENERAL

This file will contain such flutter solution data as flutter frequency, flutter velocity, and flutter damping. It will also contain flutter mode shape data.

Type of interface: IV
Interface medium: Random access mass storage
Output method: NTRAN
Created by: Flutter Solution Program (batch)
Modified by: None
Used by: Lifting Surface Flutter/Unsteady Aerodynamic Forces

PURPOSE OF INTERFACE

This file will be a storage area for flutter solution data and flutter mode shape data. This file will be used to produce terminal tabulations and graphical displays of the flutter data.

CONFIGURATION CONSTRAINTS

TBD

FORMAT

The format of this file will be determined during the functional design stage; however, it will contain the following information.

- Title information
- Number of grid points
- Grid point ID numbers and coordinates
- Number of modes

1
LIFTING SURFACE FLUTTER OUTPUT FILE - Concluded

FORMAT - Concluded

- Altitude
- Mach number
- Reduced frequency
- Flutter velocity
- Flutter damping
- Flutter frequency
- Modal displacement

LINEAR SYSTEMS DYNAMICS PROGRAM OUTPUT FILE

TBD

LOAD COEFFICIENT DATA FILE

GENERAL

This data file will contain vehicle component identification, load station identification, and the load coefficients for each of the load stations.

Type of interface: III, IV

Interface medium: Random access mass storage

Output method: NTRAN

Created by: Load Coefficient Generator

Modified by: None

Used by: Body Loads Analysis, Load Coefficient
Generator

PURPOSE OF INTERFACE

This file will provide the load coefficients needed for the body loads calculations.

CONFIGURATION CONSTRAINTS

The major file variables will have the following maximum limits:

Subfiles (NOFILE) = 25

Vehicle components (NVEHCO) = 10

Load stations (NLOADS) = 100

Modes (NMODES) = 200

Degrees of freedom (NDF) = 1200

Nodes (NNODE) = 400

Links (NLINK) = 50

LOAD COEFFICIENT DATA FILE - Continued

FORMAT

		<u>Description</u>
	24 words	Title
	4 words	Spare
File Location and Identification Block (336 words)	1 word	Number of files (NOFILE), maximum = 25
	1 word	Pointer to beginning location of file number 1
	12 words	Identification information for file number 1
	:	:
	:	:
	1 word	Pointer to beginning location of last file
	12 words	Identification information for last file
	1 word	Number of vehicle components (NVEHCO)
	1 word	Number of load stations (NOLOAD)
	1 word	Number of modes (NMODES)
Block describing file size (28 words)	1 word	Number of degrees of freedom (NDF)
	1 word	Number of nodes (NNODE)
	1 word	Number of degrees of freedom for link forces (NOLN)
	1 word	Number of links (NLINK)
	1 word	X-coordinate reference point

ORIGINAL PAGE IS OF POOR QUALITY

LOAD COEFFICIENT DATA FILE - Continued

FORMAT - Continued

		<u>Description</u>
Block describing file size (conc.)	1 word	Y-coordinate reference point
	1 word	Z-coordinate reference point
	1 word	SYM - logical variable which, if true, indicates symmetric modes are used
	1 word	ANTI - logical variable which, if true, indicates antisymmetric modes are used
	16 words	Spare
Vehicle Component ID Block (NVEHCO*3 words)	3 words	Identification of first vehicle component
	.	.
	.	.
Load coefficients for load station number 1	3 words	Identification of last vehicle component
	18 words	Load coefficients for rigid body X, Y, and Z force components (6 words each component)
	18 words	Load coefficients for rigid body X, Y, and Z moment components (6 words each component)
	NMODES*3 words	Load coefficients for elastic body loads X, Y, and Z force components (NMODES words for each component)
	NMODES*3 words	Load coefficients for elastic body loads X, Y, and Z moment components (NMODES words for each component)
	NDF*3 words	Load coefficients for force loads X, Y, and Z force components (NDF words for each component)
	NDF*3 words	Load coefficients for force loads X, Y, and Z moment components (NDF words for each component)

ORIGINAL PAGE IS OF POOR QUALITY

LOAD COEFFICIENT DATA FILE - Continued

FORMAT - Continued

		<u>Description</u>
Load coefficients for load station number 1 (conc.)	NOLN*3 words	Load coefficients for link force loads X, Y, and Z force components (NOLN words for each component)
	NOLN*3 words	Load coefficients for link force loads X, Y, and Z moment components (NOLN words for each component)
Load coefficients for load station number 2	36 words	Rigid body load coefficients
	NMODES*6 words	Elastic body load coefficients
	NDF*6 words	Force load coefficients
	NOLN*6 words	Link force load coefficients
	:	:
	:	:
Load coefficients for last load station	36 words	Rigid body load coefficients
	NMODES*6 words	Elastic body load coefficients
	NDF*6 words	Force load coefficients
	NOLN*6 words	Link force load coefficients

LOAD COEFFICIENT DATA FILE - Continued

FORMAT - Continued

	<u>Description</u>
1 word	X-coordinate of first load station
1 word	Y-coordinate of first load station
1 word	Z-coordinate for first load station
1 word	Pointer for first load station to Vehicle Component Block identifying vehicle component for this load station
.	.
.	.
1 word	X-coordinate for last load station
1 word	Y-coordinate for last load station
1 word	Z-coordinate for last load station
1 word	Pointer for last load station to Vehicle Component Block identifying vehicle component for this load station

(NLOADS*4 words)
Load Station
ID Block

ORIGINAL PAGE IS
OF POOR QUALITY

LOAD COEFFICIENT DATA FILE - Continued

FORMAT - Continued

		<u>Description</u>
NODE Coordinate ID Block (NNODE*3 words)	1 word	X-coordinate for first node
	1 word	Y-coordinate for first node
	1 word	Z-coordinate for first node
	.	.
	.	.
	.	.
	1 word	X-coordinate for last node
	1 word	Y-coordinate for last node
	1 word	Z-coordinate for last node
NODE ID block (NNODE words)	1 word	ID number for first node
	.	.
	.	.
NDF words	1 word	ID number for last node
	1 word	
	.	ID number for each degree of freedom
	.	
	1 word	

LOAD COEFFICIENT DATA FILE - Concluded

FORMAT - Concluded

		<u>Description</u>
Link Coordinate ID Block (NLINK*3 words)	1 word	X-coordinate of link number 1
	1 word	Y-coordinate of link number 1
	1 word	Z-coordinate of link number 1
	.	.
	.	.
	.	.
	1 word	X-coordinate of link number NLINK
	1 word	Y-coordinate of link number NLINK
	1 word	Z-coordinate of link number NLINK
Link ID Block (NLINK words)	1 word	ID number for first link
	.	.
	.	.
	1 word	ID number for last link

ORIGINAL PAGE IS
OF POOR QUALITY

LOAD COEFFICIENT NAMELIST INPUT DATA FILE

TBD

LOAD INPUT DATA FILE

GENERAL

This file will contain the required load coefficients at the selected load stations from the Load Coefficient Data file. It will also contain the times from the Compressed Aerodynamic Forces and Conditions File at which loads are to be calculated.

Type of interface: IV
Interface medium: Random access mass storage
Output method: NTRAN
Created by: Body Loads Analysis
Modified by: None
Used by: Body Loads Analysis

PURPOSE OF INTERFACE

All information needed for the body load calculations will be contained on this file in an easily accessible format.

CONFIGURATION CONSTRAINTS

The major file variables will have the following maximum limits:

Vehicle components (NVEHCO) = 10

Load stations (NOLOAD) = 100

Degrees of freedom for elastic body forces (NOEB) = 200

Degrees of freedom for engine and external forces (NOEF) = 200

Degrees of freedom for aerodynamic forces (NOAE) = 1200

Degrees of freedom for link forces (NOLN) = 50

LOAD INPUT DATA FILE - Continued

FORMAT

		<u>Description</u>
	24 words	Title and identification information
	8 words	Identification of Compressed Aerodynamic Force and Conditions File used to create this file
	1 word	Number of vehicle components (NVEHCO)
	1 word	Number of load stations (NOLOAD)
Header Information Block (56 words)	1 word	Number of degrees of freedom for elastic body forces (NOEB)
	1 word	Number of degrees of freedom for engine and external forces (NOEF)
	1 word	Number of degrees of freedom for aerodynamic forces (NOAE)
	1 word	Number of degrees of freedom for link forces (NOLN)
	1 word	Number of time (NITIME) contained on this file
	17 words	Spare
	3 words	Identification of first vehicle component
Vehicle Component ID Block (NVEHCO*3 words)	.	.
	.	.
	.	.
	3 words	Identification of last vehicle component

ORIGINAL PAGE IS
OF POOR QUALITY

LOAD INPUT DATA FILE - Continued

FORMAT - Continued

		<u>Description</u>
Load coefficients for load station number 1	18 words	Load coefficients for rigid body X, Y, and Z force components (6 words for each component)
	18 words	Load coefficients for rigid body X, Y, and Z moment components (6 words for each component)
	NOEB*3 words	Load coefficients for elastic body loads X, Y, and Z force components (NOEB words for each component)
	NOEB*3 words	Load coefficients for elastic body loads X, Y, and Z moment components (NOEB words for each component)
	NOEF*3 words	Load coefficients for external force loads X, Y, and Z moment components (NOEF words for each component)
	NOEF*3 words	Load coefficients for external force loads X, Y, and Z moment components (NOEF words for each component)
	NOAE*3 words	Load coefficients for aerodynamic force loads X, Y, and Z force components (NOAE words for each component)
	NOAE*3 words	Load coefficients for aerodynamic force loads X, Y, and Z moment components (NOAE words for each component)
	NOLN*3 words	Load coefficients for link force loads X, Y, and Z force components (NOLN words for each component)
	NOLN*3 words	Load coefficients for link force loads X, Y, and Z moment components (NOLN words for each component)
Load coefficients for load station number 2	36 words	Rigid body load coefficients
	NOEB*6 words	Elastic body load coefficients
	NOEF*6 words	External force load coefficients

ORIGINAL PAGE IS
OF POOR QUALITY

LOAD INPUT DATA FILE - Continued

FORMAT - Continued

		<u>Description</u>
Load coefficients for load station number 2 (conc.)	NOAE*6 words	Aerodynamic force load coefficients
	NOLN*6 words	Link force load coefficients
	:	:
Load coefficients for last load station	36 words	Rigid body load coefficients
	NOEB*6 words	Elastic body load coefficients
	NOEF*6 words	External force load coefficients
	NOAE*6 words	Aerodynamic force load coefficients
	NOLN*6 words	Link force load coefficients
	1 word	X-coordinate of first load station
Load Station ID Block (NOLOAD)*4 words)	1 word	Y-coordinate of first load station
	1 word	Z-coordinate of first load station
	1 word	Pointer for first load station to vehicle component block identifying vehicle component for this load station
	:	:
	1 word	X-coordinate for last load station

LOAD INPUT DATA FILE - Concluded

FORMAT - Concluded

		<u>Description</u>
Load Station ID Block (NOLOAD*4 words) (conc.)	1 word	Y-coordinate for last load station
	1 word	Z-coordinate for last load station
	1 word	Pointer for last load station to vehicle component block identifying vehicle component for this load station
Time and Data Pointer Block (NITIME*2 words)	1 word	First time for data contained on this file
	1 word	Data block number on Compressed Aerodynamic Force and Conditions File where the data for the first time is stored
	.	.
	.	.
	.	.
	1 word	Last time for data contained on this file
	1 word	Data block number on Compressed Aerospace Force and Conditions File where the data for the last time is stored

LOAD OUTPUT FILE

GENERAL

The Load Output File will contain the influence coefficients which will define the loads or stresses in a predefined set of elements as a function of the externally applied loads.

Type of interface: IV
Interface medium: TBD
Output method: TBD
Created by: NASTRAN Postprocessing
Modified by: TBD
Used by: NASTRAN Postprocessing

PURPOSE OF INTERFACE

This file will store the stress or load influence coefficients as developed in the NASTRAN Postprocessing and will be used as input to calculate internal loads in that same function.

CONFIGURATION CONSTRAINTS

The existing constraints will be the same as those of the Body Loads File.

FORMAT

This file should contain the following parameters:

- Control points of the model (in terms of Cartesian coordinates)
- Element sets associated with each control point
- Coefficient matrices for each element

MASS/GRID/MODAL FILE

TBD

MATERIAL DATA FILE

TBD

Q

MAXIMUM LOADS DATA FILE

TBD

Q

Q

MERGED FLIGHT CONDITIONS FILE

GENERAL

This file will contain selected flight conditions data to be used by other ISAS functions.

Type of interface: III

Interface medium: TBD

Output method: TBD

Created by: Flight Conditions Merge

Modified by: None

Used by: Flight Conditions Merge, Force Inputs to
Internal Loads Analysis

PURPOSE OF INTERFACE

This file will be a highly selected source of flight conditions data from multiple ISAS Flight Conditions Files to be used in Force Inputs to Internal Loads Analysis.

CONFIGURATION CONSTRAINTS

TBD

FORMAT

The actual format of this file will not be available until the functional design specifications have been developed. The information in this file will be the same as for the ISAS Flight Conditions File but with some additional data, as specified in section 4.13 (Flight Conditions Merge).

MODEL LOADS FILE

GENERAL

This temporary data file will contain images of NASTRAN cards. The card images will be constructed by ISAS from data contained in the ISAS data base files.

Types of interface: II, III, IV

Interface medium: Tape or tape-simulated mass storage

Output method: FORTRAN formatted write

Created by: Force Inputs to Internal Loads Analysis

Modified by: Force Inputs to Internal Loads Analysis

Used by: NASTRAN, Internal Loads and Dynamic Characteristics

PURPOSE OF INTERFACE

This file will be used to transmit data (in images of NASTRAN cards) to the batch program NASTRAN.

CONFIGURATION CONSTRAINTS

Each card will be composed of 80 Fieldata characters and contained in a single record.

FORMAT

One record
(14 words)

One record
(14 words)

End-of-file mark

End-of-file mark

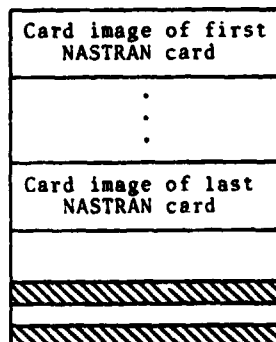

MODEL LOADS FILE - Concluded

FORMAT - Concluded

DETAILED FORMAT OF A NASTRAN CARD IMAGE

Fielddata characters for the 14 words on a NASTRAN card will be contained in card columns as shown below.

Word	Card Column
1	1-6
2	7-12
3	13-18
4	19-24
5	25-30
6	31-36
7	37-42
8	43-48
9	49-54
10	55-60
11	61-66
12	67-72
13	73-78
14	79-80

MODEL MATERIAL FILE

GENERAL

This file will contain the material properties of the model.

Type of interface: III

Interface medium: TBD

Output method: TBD

Created by: Model Material File Generator

Modified by: None

Used by: Model Weight File Generator, Properties and Allowables, Internal Loads and Dynamic Characteristics

PURPOSE OF INTERFACE

The parameters of this file will be used to provide structural material properties data to any analysis program and iSAS functions.

CONFIGURATION CONSTRAINTS

None exist at this time.

FORMAT

The format of this file will be developed as a part of the functional design specifications. Table 4.21-1 lists the data to be contained in this file.

MODEL TEMPERATURE FILE

GENERAL

This data file will contain time history temperature data for a structural model.

Type of interface: III

Interface medium: TRD

Output media: TBD

Created by: Model Temperature File Generator

Modified by: Model Temperature File Generator

Used by: Internal Loads and Dynamic Characteristics,
Model Material File Generator

PURPOSE OF INTERFACE

This file will serve as a central source for time histories of the temperature at each grid point of a structural model.

CONFIGURATION CONSTRAINTS

TBD

FORMAT

The actual format of this file will not be available until the ISAS functional design specification has been completed. The following information will be contained in the file for each time frame.

- Grid point identification
- Temperature at each grid point

MODEL WEIGHT FILE

GENERAL

The Model Weight File will contain the weight at each structural model grid point.

Type of interface: III
Interface medium: TBD
Output method: TBD
Created by: Model Weight File Generator
Modified by: Model Weight File Generator
Used by: Force Inputs to Internal Loads Analysis,
Internal Loads and Dynamic Characteristics,
Load Coefficient Generator, Model Weight
File Generator

PURPOSE OF INTERFACE

This file will provide weight data of the model for other ISAS functions.

CONFIGURATION CONSTRAINTS

TBD

FORMAT

The data on this file will include:

- Structural model grid point numbers
- Coordinates of each grid point
- Weight at each grid point, identified as taken from the Basic Weight File or calculated from data from the Model Material File

MODEL WEIGHT FILE – Concluded

FORMAT – Concluded

- Mass at each grid point
- Mass matrix [6 × 6] for each grid point, including the nine mass moment of inertia terms
- Center of gravity of the structural model
- The 24-word title information

MODIFIED BODY LOADS FILE

GENERAL

This file has the same format as the Body Loads File. The difference is that this file will contain updated elastic body loads force and moment components.

Type of interface: III, IV
Interface medium: Random access mass storage
Output method: NTRAN
Created by: Body Loads Analysis
Modified by: None
Used by: Body Loads Analysis

PURPOSE OF INTERFACE

This file will be used to produce selected tabulations and graphical displays of the body loads data.

CONFIGURATION CONSTRAINTS

The constraints for this file will be the same as for the Body Loads File (see page A-39).

FORMAT

The format for this file will be the same as for the Body Loads File (see page A-40).

MOVIE INPUT FILE

TBD

NAPSAP OUTPUT DATA FILE

TBD

NASTRAN INPUT LOADS FILE

GENERAL

This temporary data file will be used to store large numbers of different types of NASTRAN card images.

Type of interface: I, III, IV

Interface medium: Tape or tape-simulated mass storage

Output method: NTRAN

Created by: Force Inputs to Internal Loads Analysis,
Body Loads Analysis

Modified by: Force Inputs to Internal Loads Analysis

Used by: Force Inputs to Internal Loads Analysis

PURPOSE OF INTERFACE

The NASTRAN Input Loads File will be used as a storage area for a large number of NASTRAN card images which can be used to create input to NASTRAN. The blocking of the file will allow for the rapid retrieval of data and compressed storage.

CONFIGURATION CONSTRAINTS

Each data record will contain 280 words. The first unused word of the last data record will contain "999999" in Fielddata.

NASTRAN INPUT LOADS FILE - Continued

FORMAT

	<u>Type</u>	<u>Description</u>
	28 words	Header record
First record (280 words)	14 words	Image of first NASTRAN card
	.	.
	.	.
	.	.
	14 words	Image of 20th NASTRAN card
	.	.
	.	.
Last record	280 words	
	"999999"	End-of-file indicator

HEADER RECORD

24 words	A	144 characters of file identification information
1 word	I	Number of NASTRAN card images
3 words		Spare

ORIGINAL PAGE IS
OF POOR QUALITY

NASTRAN INPUT LOADS FILE - Concluded

FORMAT - Concluded

DETAILED FORMAT OF A NASTRAN CARD IMAGE

Fielddata characters for the 14 words on a NASTRAN card are contained in the file words, as shown below.

Word	Card Column
1	1-6
2	7-12
3	13-18
4	19-24
5	25-30
6	31-36
7	37-42
8	43-48
9	49-54
10	55-60
11	61-66
12	67-72
13	73-78
14	79-80

NASTRAN OUTPUT-2 FILE

GENERAL

This file will be used as input to the NASTRAN Postprocessing function. It will be created by a NASTRAN execution prior to processing the ISAS function.

Type of interface: I
Interface medium: TBD
Output method: NTRAN
Created by: Outside ISAS (NASTRAN)
Modified by: None
Used by: NASTRAN Postprocessing

PURPOSE OF INTERFACE

This file will be used to store the input bulk data defining the problem and the results of the structural analysis.

CONFIGURATION CONSTRAINTS

The constraint existing at this time is that all analysis data should be filed by load case number.

FORMAT

The data on this file should include:

- Title and subtitle
- Grid definition and coordinates
- Element definitions and properties
- Applied loads, pressures, and temperatures filed by subcase number

NASTRAN OUTPUT-2 FILE – Concluded

FORMAT – Concluded

Supplementary data that may be included on the file are:

- Grid point displacements
- Element forces
- Element stresses
- Total applied loads
- Constraint forces
- Dynamic characteristics (modes and frequencies)
- Grid point velocities and accelerations
- Mass Data

NASTRAN SORTED DATA FILE

GENERAL

This data file will be used to store several different types of data output created in the NASTRAN Postprocessing function.

Type of interface: III, IV

Interface medium: TBD

Output method: TBD

Created by: NASTRAN Postprocessing

Modified by: TBD

Used by: NASTRAN Postprocessing, Fatigue Assessment

PURPOSE OF INTERFACE

The NASTRAN Sorted Data File will store various types of data, depending on the processing option chosen in the NASTRAN Postprocessing. The file may contain results for terminal displays, and input for demand or application programs.

CONFIGURATION CONSTRAINTS

None exist at this time.

FORMAT

The format is not fixed for this file and will be dependent on its application.

PANEL FLUTTER INPUT FILE

GENERAL

This file will contain all information needed as input to the Panel Flutter Program.

Type of interface: II
Interface medium: Sequential mass storage
Output method: NTRAN
Created by: Panel Flutter function
Modified by: None
Used by: Panel Flutter Program (batch)

PURPOSE OF INTERFACE

This file will be used as a storage area for all input data needed by the Panel Flutter Program. The user can input the data at the terminal and verify that all input is correct.

CONSTRAINTS

- The maximum number of grid points will be 100.
- The maximum number of elements will be 100.

FORMAT

The format of this file will be determined during the functional design. The following information will be contained on this file.

- A 24-word title block
- Plate thickness
- Poisson's ratio
- Young's modulus
- Mass density of plate

PANEL FLUTTER INPUT FILE - Concluded

FORMAT - Concluded

- Dynamic pressure
- Mach number
- Free-stream velocity
- Panel Flutter Program control options
- 120-character title
- Grid point ID numbers
- Grid point coordinates
- Grid point external ID numbers
- Definition of elements
- Nodal constraints

PANEL FLUTTER OUTPUT FILE

GENERAL

This file will contain all data output from the Panel Flutter Program.

Type of interface: I
Interface medium: Sequential mass storage
Output method: NTRAN
Created by: Panel Flutter Program (batch)
Modified by: None
Used by: Panel Flutter function

PURPOSE OF INTERFACE

This file will be used as storage for data output by the batch Panel Flutter Program. The demand Panel Flutter function will tabulate all data contained on this file.

CONFIGURATION CONSTRAINTS

- The data will be output following the header block in 504-word (18 sector) blocks.
- The maximum number of grid points will be 100.
- The maximum number of elements will be 100.

FORMAT

The exact format of this file (header blocks, etc.) has not been determined at this time; however, it will contain multiple files and each file will have the following format.

PANEL FLUTTER OUTPUT FILE - Continued

FORMAT - Continued

		<u>Type</u>	<u>Description</u>
Header Block (28 words)	24 words	A	144 characters of file identification information
	1 word	I	Number of grid points
	1 word	I	Smallest grid point ID
	1 word	I	Largest grid point ID
	1 word	I	Number of elements
	1 word	I	First grid point ID
	3 words	R	X, Y, and Z coordinates of first grid point
	.	.	.
	1 word	I	Last grid point number
	3 words	R	X, Y, and Z coordinates of last grid point
	4 words	I	Element nodes of first element
	.	.	.
	4 words	I	Element nodes of last element

ORIGINAL PAGE IS
OF POOR QUALITY

PANEL FLUTTER OUTPUT FILE -- Concluded

FORMAT - Concluded

	<u>Type</u>	<u>Description</u>
1 word	R	First natural frequency of input panel
1 word	R	Second natural frequency of input panel
1 word	R	Calculated flutter frequency
1 word	R	Calculated dynamic pressure at flutter frequency
1 word	A	End data flag = "999999" (six alphanumeric 9's)

RESPONSE OUTPUT FILE

GENERAL

This file will be produced as output by the Gust Response and Turbulence Response Programs.

Type of interface: IV
Interface medium: TBD
Output method: TBD
Created by: Aircraft Gust and Boost Turbulence Loads
Modified by: None
Used by: Aircraft Gust and Boost Turbulence Loads

PURPOSE OF INTERFACE

This output file of the Gust Response and Turbulence Response Programs will contain the aircraft response to the power spectra for the various load conditions. The user will be able to view graphic plots and tabulations of the data. Data from this file will also be used in the formation of a Boost and Aircraft Flight Conditions File.

CONFIGURATION CONSTRAINTS

TBD

FORMAT

The file format will be determined as part of the functional design phase.

RUNNING WEIGHT FILE

GENERAL

This file will contain "running weight" data of the model calculated from the Basic Weight File and Model Weight File.

Type of interface: III

Interface medium: TBD

Output method: TBD

Created by: Model Weight File Generator

Modified by: None

Used by: Load Coef: nt Data File

PURPOSE OF INTERFACE

This file will be used to produce distributed weight data of the model.

CONFIGURATION CONSTRAINTS

TBD

FORMAT

This file should include:

- Model grid point numbers
- Coordinates of each grid point
- Discrete weights at coordinates
- Cartesian coordinates of terminal points for running weight data
- Running weight across each pair of terminal points

RUNSTREAM INPUT FILE

GENERAL

The Runstream Input File will contain images of 80-column cards to be used as input for batch analysis programs.

Type of interface: II
Interface medium: Tape or tape simulated mass storage
Output method: Simulated FORTRAN write
Created by: Internal Loads and Dynamic Characteristics
Modified by: Internal Loads and Dynamic Characteristics
Used by: NASA Structure Analysis Program (NASTRAN), Automated Structural Optimization Program (ASOP), Analysis of Aerospace Structures by the Displacement Method Program (Air Force Program), Internal Loads and Dynamic Characteristics

PURPOSE OF INTERFACE

This file will be used to store card images of a runstream, which will be constructed by the Internal Loads and Dynamic Characteristics function of ISAS, and will be input to the batch analysis programs - NASTRAN, ASOP, and Analysis of Aerospace Structures by the Displacement Method. The type of data to be included will be dependent upon the problem being analyzed and the batch program to be used.

CONFIGURATION CONSTRAINTS

Each card will be composed of 80 Fielddata characters and each card will comprise a logical record.

RUNSTREAM INPUT FILE – Concluded

FORMAT

The format of this file will be identical to the Model Loads
File format (see page A-110).



SADSAC TAPE

GENERAL

The SADSAC aerodynamic data set tape will be a binary tape created on the UNIVAC 1108 with FORTRAN write statements at medium density (556 bpi). The tape will contain pressure, force, and loads data obtained from wind tunnel tests.

Type of interface: I
Interface medium: Tape
Output method: FORTRAN write
Created by: SADSAC System
Modified by: None
Used by: SADSAC Reformat Program

PURPOSE OF INTERFACE

This tape will be the source of experimental wind tunnel pressure data for ISAS. At the present time only the pressure part, total force, and moment of the data will be retrieved for ISAS.

CONFIGURATION CONSTRAINTS

None known.

FORMAT

The data on this tape will be divided into groups (aerodynamic data sets) which will be identified by a data set type and a data set name. The three types of aerodynamic data sets will be force, local loads, and pressure data sets.

Each data set will begin with a FORTRAN logical record containing the data set type identifier written 25 times. These type

SADSAC TAPE – Continued

FORMAT – Continued

identifiers will be *FDSET (force data sets), *LDSET (local loads data sets), and *PDSET (pressure data sets). The body of the data sets will be subdivided into two sections, a header record and data records. The header record will contain the data set descriptor, reference data, and independent variable data. The data records will contain the dependent variable data.

The aerodynamic data set tape will contain one or more data sets stacked consecutively but without regard to order of data set type or name. The end of the tape will be indicated by two indicator records and a FORTRAN end-of-file mark. The first indicator record will contain the word END written 25 times, which will indicate the end of the data sets. The second indicator record will contain the word ENDFIL written 25 times, which will indicate that the FORTRAN end-of-file mark is next on the tape.

PRESSURE DATA SET CONTENT DESCRIPTION

The body of the pressure data set will be subdivided into two sections, a header record and the dependent variable data records.

Pressure Data Set Header Record

The header record will be one FORTRAN logical record written in binary. This record will contain $1020 + NMN + 2*(NPAR + NXDIM + NUMTAP)$ words. The variables in this expression are described in the header record description which follows.

<u>Variable Name</u>	<u>Type</u>	<u>Description</u>
PDSET	A	Contains the characters *PDSET, which are the pressure data set identifier

SADSAC TAPE - Continued

FORMAT - Continued

<u>Variable Name</u>	<u>Type</u>	<u>Description</u>
IDENT	A	Six-character label used to reference the data set
DDATE	A	Data set creation date, 2 words
CNFNAM	A	Data set configuration name, 8 words
ITYPE	I	Data set type: 1 = raw data; 2 = nominalized data
NMN	I	Number of values for the first independent variable (<u>≤</u> 20)
NUMTAP	I	Number of taps (positions) at which the dependent variable is measured (<u>≤</u> 2500)
NAMDEP	A	Name of the dependent variable
ANCMIN	F	The lower range used in gradient computation
ANGMAX	F	The upper range used in gradient computation
DLIMIT	F	The lower and upper limits of the first independent variable, the second independent variable, the tap position data (X, Y, and Z dimensions), and the dependent variable, respectively
NPAR	I	Number of parameter values in the data set (<u>≤</u> 10)
NAMPAR	A	Names of parameter values, NPAR words
PARVAL	F	Parameter values, NPAR words
REF	F,A	Reference data values and units, 14 words; these values represent REFS, REFL, REFB, XMPR, YMRP, ZMRP, and SCALE

SADSAC TAPE -- Continued

FORMAT -- Continued

<u>Variable Name</u>	<u>Type</u>	<u>Description</u>
IDPVAR	A	Names of the independent variables, 2 words
NAAX	I	The number of values of the second independent variable associated with each value of the first independent variable, 20 words
XMACH	F	Values of the first independent variable, 400 words
ALPHA	F	Values of the second independent variable, 400 words
IRUNNO	I	Run and rerun numbers associated with each value of the first independent variable, 40 words
NAMCON	A	Names of the wind tunnel test conditions, 4 words
TSTCON	F	Values of the wind tunnel test conditions, 80 words
NAMDIM	A	Names of the dimension variables (position of pressure taps), 3 words
NXDIM	I	Number of values for the first dimension variable (X position of pressure taps) (<250)
XDIM	F	Values of the first dimension variable (X position of pressure taps), NXDIM words
NSEC	I	Number of configuration sections (<10)
SECLIM	F	The upper and lower limit that defines each section, 11 words

SADSAC TAPE - Continued

FORMAT - Continued

<u>Variable Name</u>	<u>Type</u>	<u>Description</u>
NAMSEC	A	Names of each section, 3 words per section, 30 words
IX	I	Array of indices that associates YDIM and ZDIM with XDIM; i.e., IX(N) - IX(N-1) is the number of YDIM and ZDIM values associated with the value XDIM(N)
YDIM	F	Values of the second dimension variable (Y-position of pressure taps), NUMTAP words
ZDIM	F	Values of the third dimension variable (Z-position of pressure taps), NUMTAP words

Pressure Data Set Dependent Variable Data Records

The dependent variable data records will be $\sum_{I=1}^{NMN}$ NAAX(I) FORTRAN logical records written in binary. Each record will contain NUMTAP words.

<u>Variable Name</u>	<u>Type</u>	<u>Description</u>
CP	F	Discrete dependent variable data, NUMTAP words

FORCE DATA SET CONTENT DESCRIPTION

The body of the force data set will be subdivided into a header record and the dependent variable data records section.

Force Data Set Header Record

The header record will be one FORTRAN logical record written in binary. It will contain $64 + 4*NDV + 2*NPAR + NMN*(2*MAXNAA + 24)$

SADSAC TAPE – Continued

FORMAT – Continued

words. The variables in this expression are described in the following header record description.

<u>Variable Name</u>	<u>Type</u>	<u>Description</u>
FDSET	A	Contains the characters *FDSET, which are the force data set identifier
IDENT	A	Six-character label used to reference the data set
DDATE	A	Data set creation date, 2 words
CNFNAM	A	Data set configuration name, 3 words
ITYPE	I	Data set type: 1 = raw data; 2 = nominalized data
MODE	I	Data set mode: 1 = pitch angle varies; 2 = yaw angle varies
NMN	I	Number of values for the first independent variable (≤ 20)
MAXNAA	I	Maximum number of values for the second independent variable for the data set (largest values in the NAAZ array) (≤ 50)
NAAX	I	Number of values of the second independent variable associated with each value of the first independent variable, NMN words
XMACH	F	Values of the first independent variable, NMN*MAXNAA words
ALPHA	F	Values of the second independent variable, NMN*MAXNAA words

SADSAC TAPE -- Continued

FORMAT -- Continued

<u>Variable Name</u>	<u>Type</u>	<u>Description</u>
IRUNNO	I	Run and rerun numbers associated with each value of the first independent variable, 2*NMN words
RNL	F	Reynolds numbers, NMN words
NDM	I	Number of univariate dependent variables (<20)
NAMDM	A	Names of the univariate dependent variables, 20 words
DM	F	Univariate dependent variable data, 20*NMN words

Force Data Set Dependent Variable Data Records

There will be one unformatted FORTRAN logical record per dependent variable. Each record will contain $NMN * (MAXNAA + 1)$ words. These records will be written in the same order as the dependent variable names (NAMDEP) in the header record. The description of this record follows.

<u>Variable Name</u>	<u>Type</u>	<u>Description</u>
D	F	Discrete dependent variable data, $NMN * MAXNAA$ words
GD	F	Gradient dependent variable data, NMN words

LOADS DATA SET CONTENT DESCRIPTION

The body of the local loads data set will be subdivided into two sections, a header record and the dependent variable data records.

SADSAC TAPE - Continued

FORMAT - Continued

Loads Data Set Header Record

The header record will be one FORTRAN logical record written in binary. This record will contain $1031 + 4*NDV + 2*NPAR + NUMDIM$ words. The variables in this expression are described in the following header record description.

<u>Variable Name</u>	<u>Type</u>	<u>Description</u>
LDSET	A	Contains the characters *LDSET, which are the local data set identifier
IDENT	A	Six-character label to reference the data set
DDATE	A	Data set creation date, 8 words
CNFAM	A	Data set configuration name, 8 words
ITYPE	I	Data set type: 1 = raw data; 2 = re-analyzed data
ANGMIN	F	The lower range used in the gradient computations
ANGMAX	F	The upper range used in the gradient computations
NMN	I	Number of values for the first independent variable (≤ 20)
NDV	I	Number of dependent variables in the data set (≤ 5)
NAMDV(I,1)	A	Names of the dependent variables in the data set
NAMDV(I,2)	I	Relative sector addresses of values for the dependent variables
XMLIM	F	The lower and upper limits for the first independent variable

SADSAC TAPE - Continued

FORMAT - Continued

<u>Variable Name</u>	<u>Type</u>	<u>Description</u>
APLIM	F	The lower and upper limits for the second independent variable
DIMLIM	F	The lower and upper limits for the third independent variable
DLIMIT	F	The lower and upper limits for the dependent variable data, 2*NDV words
NP/R	I	Number of parameter values in the data set (≤ 10)
NAMPAR	A	Names of the parameter values, NPAR words
PARVAL	F	Parameter values, NPAR values
REF	F,A	Reference data values and units, 14 words
IDPVAR	A	Names of first and second independent variables, 2 words
FILREF	A	Document reference description, 3 words
NAAX	I	Number of values of the second independent variable associated with each value of the first independent variable, NMN values
XMACH	F	Values of the first independent variable, 400 words
ALPHA	F	Values of the second independent variable, 400 words
IRUNNO	I	Run and rerun numbers associated with each value of the first independent variable, 4 words

SADSAC TAPE – Continued

FORMAT – Continued

<u>Variable Name</u>	<u>Type</u>	<u>Description</u>
NAMCON	A	Names of the wind tunnel test conditions, 4 words
TSTCOM	F	Values of the wind tunnel test conditions, 80 words
NAMDIM	A	Name of the third independent (dimension) variable, 1 word
NUMDIM	I	Number of values of the dimension variable (≤ 250)
DIM	F	Values of the dimension variable, NUMDIM words
NSEC	I	Number of configuration sections (≤ 10)
SECLIM	F	The upper and lower limits that define each section, 11 words
NAMSEC	A	Names of each section, 3 words per section, 30 words

Logical Data Set Dependent Variable Data Records

The dependent variable data records will be NDV*NMN FORTRAN logical records written in binary. Each record will contain $21 \times (1 + \text{NUMDIM} + \text{NSEC})$ words. These records will be written in the same order as the dependent variable names [NAMDV(I,1)] in the header record. There will be NMN records for each dependent variable.

<u>Variable Name</u>	<u>Type</u>	<u>Description</u>
NDV	I	Number of dependent variables in the data set (≤ 10)

SADSAC TAPE - Continued

FORMAT - Continued

<u>Variable Name</u>	<u>Type</u>	<u>Description</u>
NDPVAR	,I	Names and relative sector addresses of the dependent variables, 2*NDV words
XMDIM	F	The lower and upper limit for the first independent variable, 2 words
APLIM	F	The lower and upper limit for the second independent variable, 2 words
DLIMIT	F	The lower and upper limits for the dependent variable data, 2*NDV words
ANGMIN	F	The lower range used in the gradient computations
ANGMAX	F	The upper range used in the gradient computations
NPAR	I	Number of parameter values in the data set (<10)
NAMPAR	A	Names of the parameter values, NPAR words
PARVAL	F	Parameter values, NPAR words
REF	F,A	Reference data values and units, 14 words; these values represent REFS, REFL, REFB, XMRP, YMRP, ZMRP, and SCALE
IDPVAR	A	Names of the independent variable, 2 words
FILREF	A	Document reference description, 3 words
D	F	Discrete dependent variable data, 20*NUMDIM words
GD	F	Gradient dependent variable data, NUMDIM words

SADSAC TAPE -- Concluded

FORMAT -- Concluded

<u>Variable Name</u>	<u>Type</u>	<u>Description</u>
DS	F	Section dependent variable data, 20*NSEC words
GDS	F	Gradient section dependent variable data, NSEC words
DV	F	Vehicle dependent variable data, 20 words
GDV	F	Gradient vehicle dependent variable data

SCRIBL OUTPUT FILE

GENERAL

This permanent data file will contain NASTRAN force and moment card images. For each grid point, there will be one of each card type. This data will include scaled force components (F_x , F_y , F_z) and the scaled moment components (M_x , M_y , M_z).

Type of interface: I

Interface medium: Random access mass storage

Output method: NTRAN

Created by: Scaled Rigid Body Loads Program (SCRIBL)

Modified by: None

Used by: Force Inputs to Internal Loads Analysis

PURPOSE OF INTERFACE

This file will be used as input to produce images of NASTRAN cards, which will contain scaled body loads to be included in a NASTRAN analysis.

CONFIGURATION CONSTRAINTS

The length of the Structure ID Block and the Substructure ID Blocks will be fixed at 84 words. Only the number of structures and substructures defined in these 84 words will be allowed on this file.

SCRIBL OUTPUT FILE -- Continued

FORMAT

		<u>Type</u>	<u>Description</u>
Title Block	24 words	A	144 characters of file identification information
	1 word	I	Sector address of first unused sector
	3 words		Spare
Structure ID Block	1 word	I	Number of structures contained on file
	1 word	A	ID of first structure
	1 word	I	Pointer (word index within this record) to location of substructures associated with first structure
	.		.
	.		.
	1 word	A	ID of last structure
	1 word	I	Pointer (word index within this record) to location of substructures associated with last structure
	1 word	I	Number of substructures in the first structure
	1 word	A	ID of first substructure in the first structure
	1 word	I	Sector address of data for this first substructure
Substructure ID Block of first structure	1 word	I	Number of grid points in this substructure
	.		.
	.		.
	1 word	A	ID of last substructure in the first structure
	1 word	I	Sector address of data for this last substructure
	1 word	I	Number of grid points in this substructure
	.		.
	.		.

SCRIBL OUTPUT FILE - Continued

FORMAT - Continued

	<u>Type</u>	<u>Description</u>
Substructure ID Block of last structure	1 word	I Number of substructures in the last structure
	1 word	A ID of first substructure in the last structure
	1 word	I Sector address of data for this substructure
	1 word	I Number of grid points in this substructure
	.	.
	.	.
	1 word	A ID of last substructure in the last structure
	1 word	I Sector address of data for this substructure
	1 word	I Number of grid points in this substructure
	.	Unused words at the end of the Structure and Substructure ID Blocks. The total length of these blocks is fixed at 84 words. These unused words will be used as additional structures and substructures are added to the file
	.	
	First Data Block	Data block for first substructure in the first structure. See description of data block on following page
	.	
	.	
Last Data block	Data block for last substructure in the last structure. See description of data block on following page	
24 words	A 144 characters of information describing this substructure	
4 words	Spare	
1 word	I Load set identification (SID) for first grid point	
1 word	I Grid point identification number for first grid point	
1 word	R Scale factor (S) for first grid point	

ORIGINAL PAGE IS OF POOR QUALITY

SCRIBL OUTPUT FILE – Concluded

FORMAT – Concluded

	<u>Type</u>	<u>Description</u>
1 word	R	X-force component (F_x) for first grid point
1 word	R	Y-force component (F_y) for first grid point
1 word	R	Z-force component (F_z) for first grid point
1 word	R	X-moment component (M_x) for first grid point
1 word	R	Y-moment component (M_y) for first grid point
1 word	R	Z-moment component (M_z) for first grid point
.		.
.		.
.		.
1 word	I	Load set identification (SID) for last grid point
1 word	I	Grid point identification number for last grid point
1 word	R	Scale factor (S) for last grid point
1 word	R	X-force component (F_x) for last grid point
1 word	R	Y-force component (F_y) for last grid point
1 word	R	Z-force component (F_z) for last grid point
1 word	R	X-moment component (M_x) for last grid point
1 word	R	Y-moment component (M_y) for last grid point
1 word	R	Z-moment component (M_z) for last grid point

SECTION PROPERTIES AND ALLOWABLES FILE

GENERAL

This file will contain the collected material properties, geometric properties, and computed allowable stress for each section of a vehicle.

Type of interface: IV
Interface medium: TBD
Output method: TBD
Created by: Properties and Allowables
Modified by: None
Used by: Properties and Allowables

PURPOSE OF INTERFACE

This file will be used by the Properties and Allowables function as a central storage area for all of the input data required to calculate allowables.

CONFIGURATION CONSTRAINTS

Data for only one structure can be placed on the file. The structure can have a maximum of 30 regions (substructures).

FORMAT

The actual format of this file will not be developed until the functional design specifications are completed. The information listed below will be contained in the file for each station of each region.

- Section identification number
- Section type identification
- X, Y, and Z coordinates of station

SECTION PROPERTIES AND ALLOWABLES FILE – Concluded

FORMAT – Concluded

- Geometry parameters (b , t , R , ϕ)
- Material compressive modulus (E)
- Material tensile ultimate stress (FTU)
- Poisson's ratio (μ)
- Material compressive yield stress (FC)
- Material shear stress (FS)
- Material secant modulus (E_s)
- Material tangent modulus (E_t)
- Curve shape factor (η)
- Curve secant yield stress ($F_{0.7}$)
- Local buckling allowable stress (FCR)
- Crippling allowable stress (FCC)
- Shear buckling allowable stress (FSCR)
- Section properties
 - a. For panels – equivalent thickness (\bar{t}), radius of gyration (ρ)
 - b. For beams – cross sectional area, centroid location, moment of inertia about each beam axis, radii of gyration about each beam axis, the polar moment of inertia, the torsional constant for the section, and the shear areas of the section
- 24-words of title information

↓

SELECTED MODAL DATA FILE

TBD

(

SKIN FRICTION DATA FILE

TBD

STANDARD ATMOSPHERE FILE

TBD

STATIC AERODYNAMIC INFLUENCE COEFFICIENTS FILE

GENERAL

This file will be created by the Lifting Surface Flutter/Unsteady Aerodynamic Forces function and will contain grid points, aerodynamic influence coefficients, and other aerodynamic parameters.

Type of interface: III

Interface medium: Random access mass storage

Output method: NTRAN

Created by: Lifting Surface Flutter/Unsteady Aerodynamic Forces

Modified by: None

Used by: Static Aeroelasticity

PURPOSE OF INTERFACE

This file will be used as a storage area for aerodynamic influence coefficients data and will be used as input to the Static Aeroelasticity function.

CONFIGURATION CONSTRAINTS

TID

FORMAT

The format of this file will be the same as the Aerodynamic Influence Coefficients file.

STATIC AEROELASTICITY FORCE COEFFICIENT DATA FILE

GENERAL

This file will contain force coefficient data for the wing and vertical tail and will be a product of the Aerodynamic Loads function.

Type of interface: I, III
Interface medium: Random access mass storage
Output method: NTRAN
Created by: Aerodynamic Loads
Modified by: None
Used by: Static Aeroelasticity

PURPOSE OF INTERFACE

Wing and vertical tail force coefficient data will be calculated in the Aerodynamic Loads function and stored in this file. The data can be displayed at the terminal. The file will subsequently be used as input to the demand Static Aeroelasticity Correction Program (STAC).

CONFIGURATION CONSTRAINTS

Constraints will correspond to those of the Force Coefficient Data File (see page A-62). However, data will be limited to the wing and vertical tail only.

FORMAT

The format for this file will be identical to that for the Force Coefficient Data File (see page A-66).

STATIC AEROELASTICITY INPUT FILE

GENERAL

The input data for the batch Static Aeroelasticity Program will be obtained from three sources – card or terminal, Structural Influence Coefficients File, and Aerodynamic Influence Coefficients File. The demand Static Aeroelasticity function will provide the user with a method of collecting all of the required data and will supply the data to the Static Aeroelasticity Program through the Static Aeroelasticity Input File.

Type of interface: II
Interface medium: Sequential mass storage
Output method: NTRAN
Created by: Static Aeroelasticity function
Modified by: Static Aeroelasticity function
Used by: Static Aeroelasticity Program (STAP01)

PURPOSE OF INTERFACE

This file will contain all of the input required by the Static Aeroelasticity Program. The input will consist of output options, grid point identifications, grid point location data, pressure coefficients, aerodynamic influence coefficient matrices, structural influence coefficient matrices, and other data.

CONFIGURATION CONSTRAINTS

- The maximum number of aerodynamic panel control points will be 100.
- The maximum number of columns of C_p points will be 16.
- The maximum number of words in case description will be 144.

STATIC AEROELASTICITY INPUT FILE - Continued

FORMAT

Description

	Description block for first case (see format on page A-158)
	Data block for first case (see format on page A-159)
⋮	⋮
	Description block for last case (see format on page A-158)
	Data block for last case (see format on page A-159)

DESCRIPTION BLOCK

Type

Description

24 words	A	File title and information block
1 word	I	If first case, number of cases contained on file (NCASAS); for all other cases, spare
1 word	I	Number of words in case description (NT), maximum = 144
1 word	I	Total number of aerodynamic panel control points (NP), maximum = 100
1 word	I	Number of columns of C_p points (NPNL), maximum = 16
10 words	I	Batch program output options (IOPT) IOPT(1) = 2, will list input and output data = 0, will not list IOPT(2) = 1, will generate 4060 plots associated with input data = 2, will generate 4060 plots associated with output data = 3, will generate 4060 plots associated with both input and output data IOPT(3) = 1, wing structure = 2, vertical tail structure IOPT(4) = 1, will compute divergent dynamic pressure

ORIGINAL PAGE IS
OF POOR QUALITY

STATIC AEROELASTICITY INPUT FILE - Continued

FORMAT - Continued

DESCRIPTION BLOCK - Concluded

	<u>Type</u>	<u>Description</u>
NPNL words	I	Number of C_p points per column (NC)
$X^†$ words		Spare

DATA BLOCK

	<u>Type</u>	<u>Description</u>
NP words	I	Identification (ID) of aerodynamic panel control points
NT words	A	General description of case (TITLE)
1 word	R	Angle of attack (alpha) in degrees.
1 word	R	Mach number (RMACH)
1 word	R	Dynamic pressure (DP) in lb/in. ²
1 word	R	Y-coordinate of wing root (YR) in inches
1 word	R	Z-coordinate of vertical tail root (ZR) in inches
NP words	R	X-coordinate of each C_p point (X) in inches
NP words	R	Y-coordinate of each C_p point (Y) in inches
NP words	R	Z-coordinate of each C_p point (Z) in inches

[†]X - 56 14 - NPNL.

L

STATIC AEROELASTICITY INPUT FILE - Concluded

FORMAT - Concluded

DATA BLOCK - Concluded

	<u>Type</u>	<u>Description</u>
NP words	R	Aerodynamic panel areas (B) in inches squared
NP words	R	Rigid pressure coefficients (DCPR)
NP*NP words	R	Aerodynamic influence coefficients matrix (A) in radians
NP*NP words	R	Structure influence coefficients matrix (S) in radians

ORIGINAL PAGE IS
OF POOR QUALITY

0

STATIC AEROELASTICITY OUTPUT FILE

GENERAL

This file will contain the program output of the Static Aeroelasticity Program (STAP).

Type of interface: I
Interface medium: TBD
Output method: TBD
Created by: Static Aeroelasticity Program (STAP)
Modified by: Static Aeroelasticity
Used by: Static Aeroelasticity, Aerodynamic Loads

PURPOSE OF INTERFACE

With this file, the user can view, on the remote terminal, data produced by STAP. The file will then be reformatted as necessary and used as input to the Aerodynamic Loads function.

CONFIGURATION CONSTRAINTS

A maximum of five cases (NCASES) will be the only configuration constraint.

FORMAT

The file format will be determined during the functional specifications phase. The file will contain the following:

- Job title/ID information
- Angle of attack
- Mach number
- Wing root Y-coordinate

STATIC AEROELASTICITY OUTPUT FILE – Concluded

FORMAT – Concluded

- Vertical tail root Z-coordinate
- Divergent dynamic pressure
- Total rigid panel load
- Total aeroelastic panel load due to flexibility
- Wing and tail moments
- Flexible-to-rigid load ratio
- Control point X, Y, and Z coordinates
- Aeroelastic panel areas
- Rigid pressure coefficients
- Structural slope
- Pressure coefficients due to flexibility
- Flexible-to-rigid panel pressure ratio
- Rigid aeroelastic panel load
- Aeroelastic panel load due to flexibility
- Flexible-to-rigid panel loading ratio

STIFFNESS, MASS, AND MODES FILE

TBD

STRESS DATA FILE

TBD

STRUCTURAL ALLOWABLE DATA FILE

GENERAL

This file will represent a central source for structural allowable data for each section of a unique model.

Type of interface: III

Interface medium: TBD

Output method: TBD

Created by: Properties and Allowables

Modified by: Properties and Allowables

Used by: Internal Loads and Dynamic Characteristics

PURPOSE OF INTERFACE

This file will provide structural allowable data for a unique model to other ISAS functions and to batch structural analysis programs.

CONFIGURATION CONSTRAINTS

Data for only one structure can be placed on the file. The structure can contain a maximum of 30 regions (substructures).

FORMAT

The actual format of this file will not be developed until the ISAS functional design specifications are completed. The information listed below will be contained in the file for each section of each region.

- Section identification number
- Section type identification
- X, Y, and Z coordinates of station

STRUCTURAL ALLOWABLE DATA FILE - Concluded

FORMAT - Concluded

- Allowable compressive stress (F_c)
- Allowable torsion stress (F_{tor})*
- Allowable bending stress (F_b)*
- Allowable shear stress (F_s)
- Allowable stress due to pressure (F_p)*
- Allowable biaxial stress field (F_x, F_y)*
- Allowable tension stress (F_t)

*The software to calculate values for these parameters has not been defined and will not be included in the initial Phase B detailed requirements document.

STRUCTURAL INFLUENCE COEFFICIENTS FILE

TBD

TEMPERATURE DATA FILE

GENERAL

The Temperature Data File, which will be created outside of ISAS, will contain a time history of the thermal loading of a vehicle.

Type of interface: I
Interface medium: TBD
Output method: TBD
Created by: Thermal Technology Branch
Modified by: No ISAS function
Used by: Model Temperature File Generator

PURPOSE OF INTERFACE

This file will be used to transmit a description of the thermal model and values of temperature at each thermal node to the Structures Branch (FS2) and ISAS. The data, contained in this file, will be used to calculate temperature at each structural grid point.

CONFIGURATION CONSTRAINTS

TBD

FORMAT

The actual format of this file will not be available until the ISAS functional design specifications have been completed. The following is a partial list of the information to be contained in the file.

- Thermal node point identification
- X, Y, Z coordinates of thermal node points

TEMPERATURE DATA FILE - Concluded

FORMAT - Concluded

- Time
- Temperature (°F) of each thermal node point

The file can contain more than one time frame.

TEMPORARY MODEL WEIGHT FILE

GENERAL

This file will contain subtotal values of weights calculated while processing the Model Weight File.

Type of interface: IV
Interface medium: TBD
Output method: TBD
Created by: Model Weight File Generator
Modified by: None
Used by: Model Weight File Generator

PURPOSE OF INTERFACE

A comparison of the subtotals on this file will be used to determine that the Model Weight File is being built satisfactorily.

CONFIGURATION CONSTRAINTS

Subtotals can be calculated for subsystems, substructures, and so forth, to the lowest identifiable part of the model.

FORMAT

This file should include:

- Substructure or identifiable part of model
- Subtotal for that part
- Identification of subtotal as to source (Basic Weight File or structural model data)

TRAJECTORY DATA FILE

TBD

TRANSFORM EQUATIONS FILE

TBD

TURBULENCE SPECTRA FILE

TBD

UNSTEADY AERODYNAMIC GENERALIZED FORCES FILE

GENERAL

This file will be a product of the batch Adjusted Aerodynamics Program.

Type of interface: IV

Interface medium: TBD

Output method: TBD

Created by: Aircraft Gust and Boost Turbulence Loads

Modified by: None

Used by: Aircraft Gust and Boost Turbulence Loads

PURPOSE OF INTERFACE

This file will contain grid points, reduced frequencies, generalized forces, aerodynamic influence coefficients matrix, and other aerodynamic parameters. It will be used to furnish data for the creation of the Gust Input File. Data tabulations and graphics will be available at the terminal.

CONFIGURATION CONSTRAINTS

TBD

FORMAT

TBD

UNSTEADY AERODYNAMIC INPUT FILE

GENERAL

This file will contain modal frequency data, interpolated modal displacement data, Mach number, air density, and set of reduced frequencies.

Type of interface: IV

Interface medium: Random access mass storage

Output method: NTRAN

Created by: Lifting Surface Flutter/Unsteady Aerodynamic Forces

Modified by: None

Used by: Lifting Surface Flutter/Unsteady Aerodynamic Forces

PURPOSE OF INTERFACE

All data needed by the Unsteady Aerodynamic Computational Program will be contained on this single input file.

CONFIGURATION CONSTRAINTS

TBD

FORMAT

The format of this file will be determined during the functional design stage; however, it will contain the following information:

- Title information
- Number of grid points
- Grid point ID numbers and grid point coordinates
- Number of modes

UNSTEADY AERODYNAMIC INPUT FILE - Concluded

FORMAT - Concluded

- **Modal frequencies**
- **Interpolated modal displacement data**
- **Mach number**
- **Air density**
- **Set of reduced frequencies**

UNSTEADY AERODYNAMIC OUTPUT FILE

GENERAL

This file will contain aerodynamic influence coefficients, downwash distribution matrix, aerodynamic pressure distribution matrix, unsteady aerodynamic generalized forces, and the area matrix.

Type of interface: IV
Interface medium: Random access mass storage
Output method: NTRAN
Created by: Lifting Surface Flutter/Unsteady Aerodynamic Forces
Modified by: None
Used by: Lifting Surface Flutter/Unsteady Aerodynamic Forces

PURPOSE OF INTERFACE

This file will be a storage area for all unsteady aerodynamic data output by the batch Unsteady Aerodynamic Computational Program. This file will be used to produce terminal tabulations and graphical displays.

CONFIGURATION CONSTRAINTS

TBD

FORMAT

The format of this file will be determined during the functional design stage; however, it will contain the following information.

- Title information
- Number of grid points

UNSTEADY AERODYNAMIC OUTPUT FILE – Concluded

FORMAT – Concluded

- Grid point ID numbers and coordinates
- Number of modes
- Altitude
- Mach number
- Reduced Frequency
- Downwash distribution matrix
- Unsteady aerodynamic influence coefficients matrix
- ARea matrix
- Aerodynamic pressure distribution matrix
- Unsteady aerodynamic generalized forces matrix

UNSTEADY FLUTTER GENERALIZED FORCES FILE

GENERAL

This file will be used exclusively in the Lifting Surface Flutter/Unsteady Aerodynamic Forces function and will contain grid points, reduced frequencies, unsteady aerodynamic generalized forces, and other aerodynamic parameters.

Type of interface: IV

Interface medium: Random access mass storage

Output method: NTRAN

Created by: Lifting Surface Flutter/Unsteady Aerodynamic Forces

Modified by: None

Used by: Lifting Surface Flutter/Unsteady Aerodynamic Forces

PURPOSE OF INTERFACE

This file will be used as a storage area for unsteady aerodynamic generalized forces data. This file will be used to transmit data from the Unsteady Aerodynamic Forces subsystem to the Lifting Surface Flutter subsystem of the Lifting Surface Flutter/Unsteady Aerodynamic Forces function.

CONFIGURATION CONSTRAINTS

TBD

FORMAT

The format of this file will be determined during the functional design stage.

UNSTEADY GUST GENERALIZED FORCES FILE

GENERAL

This file will be created by the Lifting Surface Flutter/Unsteady Aerodynamic Forces function and will contain grid points, reduced frequencies, unsteady aerodynamic generalized forces, and other aerodynamic parameters.

Type of interface: III

Interface medium: Random access mass storage

Output method: NTRAN

Created by: Lifting Surface Flutter/Unsteady Aerodynamic Forces

Modified by: None

Used by: Aircraft Gust and Boost Turbulence Loads

PURPOSE OF INTERFACE

This file will be used as a storage area for unsteady aerodynamic generalized forces data. This file will be used as input to the Aircraft Gust and Boost Turbulence Loads function.

CONFIGURATION CONSTRAINTS

TBD

FORMAT

The format of this file will be determined during the functional design stage.

USER MODAL FILE

GENERAL

This data file will contain modal information required by ISAS and several batch analysis programs.

Type of interface: I
Interface medium: Tape
Output method: Unformatted FORTRAN write
Created by: NASTRAN-to-FRISBE Modal Tape Conversion Program (NASTOF)
Modified by: TBD
Used by: POGO Modal Response Program, Lifting Surface Flutter/Unsteady Aerodynamic Forces, Random Vibration Analysis, Aircraft Gust and Boost Turbulence Loads, Load Coefficient Generator, FRISBE, FLAP, BOLO, FREQ, TAPCAR, TAPMOD, BROWN, TRANS, MERGE, FTD, LOCO, SATOF, NRDBOK, MODCON, TAPCON, CONDIM

PURPOSE OF INTERFACE

This data file will provide a necessary data link between NASTRAN and other programs and ISAS functions which require modal information.

CONFIGURATION CONSTRAINTS

- The maximum number of grid points (NNODES) will be 300.
- The maximum total number of degrees of freedom (NDF) will be 750.

USER MODAL FILE - Continued

FORMAT

		<u>Type</u>	<u>Description</u>
	1 word	I	Number of data sets on tape + 1 (NFILES)
	EOF		
Title Record	12 words	A	72-characters of alphanumeric title
	1 word	I	Total number of degrees of freedom (NDF)
Record type 2	1 word	I	Number of modes (NMODE)
	NDF words	I	Array of degree-of-freedom indicators
	1 word	I	Number of grid points (NNODES)
	NNODES words	I	Identification numbers of grid points
	3*NNODES words	R	X, Y, and Z coordinates of each grid point
	NDF words	R	Diagonal mass matrix
	1 word	R	Generalized mass
Record type 3	1 word	R	Modal frequency
	NDF words	R	Modal deflections at that frequency
	.		Record type 3 for modes 2 through NMODES

ORIGINAL PAGE IS
OF POOR QUALITY

USER MODAL FILE - Concluded

FORMAT - Concluded

	<u>Type</u>	<u>Description</u>
Record type 4	I	1 word First grid point identification number
	A	4 words 24-character descriptive name associated with first grid point
	.	.
	.	.
Record type 5	I	1 word Identification number of NNODEth grid point
	A	4 words 24-character descriptive name associated with NNODEth grid point
	R	NDF words First row of mass matrix
	.	.
	.	.
	R	NDF words NDFth row of mass matrix
	EOF	
		Data for data set 2 (record types 1 through 5)
		EOF
		.
		.
		.
		Data for data set NFILES-1 (record types 1 through 5)
		EOF

USER MODEL FILE

GENERAL

This file will contain the detailed geometry of the model to be analyzed. The model can be of differing types consistent with the type of analysis to be performed.

Type of interface: II, III

Interface medium: Random access mass storage

Output method: NTRAN

Created by: User Model File Generator

Modified by: User Model File Generator, Force Inputs to Internal Loads Analysis

Used by: Aerodynamic Data Base Generator, Static Aeroelasticity, FOCAP, Aerodynamic Loads, Skin Friction Drag Program, Model Material File Generator, Element Property File Generator, Load Coefficient Generator, Lifting Surface Flutter/Unsteady Aerodynamic Forces, Panel Flutter, Model Weight File Generator, Random Vibration Analysis, Aerodynamic Calculations for Wing and Body Elements, Internal Loads and Dynamic Characteristics, Force Inputs to Internal Loads Analysis, POGO Stability

PURPOSE OF INTERFACE

Various ISAS functions and structural analysis batch programs require information which describes the model. This file will represent a common source for geometry data for all of these programs. The use of a single source and unique format will allow the same data to be used in multiple programs without any transformation and the resulting chance of error.

USER MODEL FILE - Continued

CONFIGURATION CONSTRAINTS

The constraints for this file will be the same as for the Basic Geometry Data File.

USER MODEL FILE - Continued

FORMAT

DETAILED FORMAT

		<u>Description</u>				
Title Record	28 words	162 characters of title information				
	1 word	Pointer (sector count) to table containing NASTRAN resequencing information				
2 words	1 word	Number of structures (NST) contained on file				
	1 word	<table border="1"> <tr><td align="center" colspan="2">First six characters of ID of first structure</td></tr> <tr><td align="center" colspan="2">36 bits</td></tr> </table>	First six characters of ID of first structure		36 bits	
First six characters of ID of first structure						
36 bits						
4*NST words	1 word	<table border="1"> <tr><td align="center" colspan="2">Second six characters of ID of first structure</td></tr> <tr><td align="center" colspan="2">36 bits</td></tr> </table>	Second six characters of ID of first structure		36 bits	
	Second six characters of ID of first structure					
	36 bits					
	1 word	<table border="1"> <tr> <td align="center">Last three characters of ID of first structure</td> <td align="center">Code corresponding to ID of first structure</td> </tr> <tr> <td align="center">1-18</td> <td align="center">19-36</td> </tr> </table>	Last three characters of ID of first structure	Code corresponding to ID of first structure	1-18	19-36
	Last three characters of ID of first structure	Code corresponding to ID of first structure				
	1-18	19-36				
	1 word	<table border="1"> <tr><td align="center" colspan="2">Pointer (word index within this record) to location of data for first structure</td></tr> <tr><td align="center" colspan="2">36 bits</td></tr> </table>	Pointer (word index within this record) to location of data for first structure		36 bits	
	Pointer (word index within this record) to location of data for first structure					
	36 bits					
	.	.				
.	.					
.	.					
1 word	<table border="1"> <tr><td align="center" colspan="2">First six characters of ID of last structure</td></tr> <tr><td align="center" colspan="2">36 bits</td></tr> </table>	First six characters of ID of last structure		36 bits		
First six characters of ID of last structure						
36 bits						
1 word	<table border="1"> <tr><td align="center" colspan="2">Second six characters of ID of last structure</td></tr> <tr><td align="center" colspan="2">36 bits</td></tr> </table>	Second six characters of ID of last structure		36 bits		
Second six characters of ID of last structure						
36 bits						
1 word	<table border="1"> <tr> <td align="center">Last three characters of ID of last structure</td> <td align="center">Code corresponding to ID of last structure</td> </tr> <tr> <td align="center">1-18</td> <td align="center">19-36</td> </tr> </table>	Last three characters of ID of last structure	Code corresponding to ID of last structure	1-18	19-36	
Last three characters of ID of last structure	Code corresponding to ID of last structure					
1-18	19-36					
1 word	<table border="1"> <tr><td align="center" colspan="2">Pointer (word index within this record) to location of data for last structure</td></tr> <tr><td align="center" colspan="2">36 bits</td></tr> </table>	Pointer (word index within this record) to location of data for last structure		36 bits		
Pointer (word index within this record) to location of data for last structure						
36 bits						
1 word	1 word	Number of substructures in the first structure (NSS ₁)				

ORIGINAL PAGE IS OF POOR QUALITY

USER MODEL FILE - Continued

FORMAT - Continued

DETAILED FORMAT - Continued

		<u>Description</u>				
4*NSS ₁ words	1 word	<table border="1" style="width: 100%;"> <tr> <td colspan="2">First six characters of ID of first substructure of first structure</td> </tr> <tr> <td colspan="2" style="text-align: center;">36 bits</td> </tr> </table>	First six characters of ID of first substructure of first structure		36 bits	
	First six characters of ID of first substructure of first structure					
	36 bits					
	1 word	<table border="1" style="width: 100%;"> <tr> <td colspan="2">Second six characters of ID of first substructure of first structure</td> </tr> <tr> <td colspan="2" style="text-align: center;">36 bits</td> </tr> </table>	Second six characters of ID of first substructure of first structure		36 bits	
	Second six characters of ID of first substructure of first structure					
	36 bits					
	1 word	<table border="1" style="width: 100%;"> <tr> <td style="width: 50%;">Last three characters of ID of first substructure of first structure</td> <td style="width: 50%;">Code corresponding to ID of first substructure of first structure</td> </tr> <tr> <td style="text-align: center;">1-18</td> <td style="text-align: center;">19-36</td> </tr> </table>	Last three characters of ID of first substructure of first structure	Code corresponding to ID of first substructure of first structure	1-18	19-36
	Last three characters of ID of first substructure of first structure	Code corresponding to ID of first substructure of first structure				
	1-18	19-36				
	1 word	<table border="1" style="width: 100%;"> <tr> <td colspan="2">Pointer (word index within this record) to location of data for first substructure of first structure</td> </tr> <tr> <td colspan="2" style="text-align: center;">36 bits</td> </tr> </table>	Pointer (word index within this record) to location of data for first substructure of first structure		36 bits	
	Pointer (word index within this record) to location of data for first substructure of first structure					
	36 bits					
.	.					
.	.					
.	.					
1 word	<table border="1" style="width: 100%;"> <tr> <td colspan="2">First six characters of ID of last substructure of first structure</td> </tr> <tr> <td colspan="2" style="text-align: center;">36 bits</td> </tr> </table>	First six characters of ID of last substructure of first structure		36 bits		
First six characters of ID of last substructure of first structure						
36 bits						
1 word	<table border="1" style="width: 100%;"> <tr> <td colspan="2">Second six characters of ID of last substructure of first structure</td> </tr> <tr> <td colspan="2" style="text-align: center;">36 bits</td> </tr> </table>	Second six characters of ID of last substructure of first structure		36 bits		
Second six characters of ID of last substructure of first structure						
36 bits						
1 word	<table border="1" style="width: 100%;"> <tr> <td style="width: 50%;">Last three characters of ID of last substructure of first structure</td> <td style="width: 50%;">Code corresponding to ID of last substructure of first structure</td> </tr> <tr> <td style="text-align: center;">1-18</td> <td style="text-align: center;">19-36</td> </tr> </table>	Last three characters of ID of last substructure of first structure	Code corresponding to ID of last substructure of first structure	1-18	19-36	
Last three characters of ID of last substructure of first structure	Code corresponding to ID of last substructure of first structure					
1-18	19-36					
1 word	<table border="1" style="width: 100%;"> <tr> <td colspan="2">Pointer (word index within this record) to location of data for last substructure of first structure</td> </tr> <tr> <td colspan="2" style="text-align: center;">36 bits</td> </tr> </table>	Pointer (word index within this record) to location of data for last substructure of first structure		36 bits		
Pointer (word index within this record) to location of data for last substructure of first structure						
36 bits						
.	.					
.	.					
.	.					
1 word	Number of substructures in NSTth structure (NSS _N)					

USER MODEL FILE - Continued

FORMAT - Continued

DETAILED FORMAT - Continued

		<u>Description</u>	
4*NSS _N words	1 word	First six characters of ID of first substructure of NST _t structure	
	:	:	
	:	:	
	:	:	
	1 word	First six characters of ID of NSS _N th substructure of NST _t structure	
		36 bits	
	1 word	Second six characters of ID of NSS _N th substructure of NST _t structure	
		36 bits	
	1 word	Last three characters of ID of NSS _N th substructure of NST _t structure	Code corresponding to ID of NSS _N th substructure of NST _t structure
		1-18	19-36
	1 word	Pointer (word index within this record) to location of data for NSS _N th substructure of last NST _t structure	
		36 bits	
10 words repeated for each substructure contained on the file	1 word	Not used	Number of grid points/tap positions (NGP)
		1-18	19-36
	1 word	Not used	Pointer (sector count) to grid point/tap position and X, Y, Z Coordinate table for first substructure of first structure
		1-18	19-36
	1 word	Not used	Pointer (sector count) to aerodynamics information for fuselage, wing, or vertical tail
	1-18	19-36	
	1 word	Not used	Pointer (sector count) to Element Header Block
		1-18	19-36

ORIGINAL PAGE IS
OF POOR QUALITY

USER MODEL FILE - Continued

FORMAT - Continued

DETAILED FORMAT - Concluded

		<u>Description</u>	
10 words repeated for each substructure contained on the file (conc.)	1 word	Not used 1-18	Pointer (sector count) to Coordinate System Identification Table 19-36
	1 word	Not used 1-18	Pointer (sector count) to additional surface definition data 19-36
	1 word	Not used 1-18	Pointer (sector count) to Cell Identification Table 19-36
	1 word	Not used 1-18	Not used 19-36
	1 word	Not used 1-18	Pointer (sector count) to grid point description data 19-36
	1 word	Not used 1-18	Not used 19-36

USER MODEL FILE - Continued

FORMAT - Continued

AERODYNAMIC INFORMATION TABLE

		<u>Description</u>
6 words	1 word	L for fuselage B _w for wing B _v for vertical tail
	1 word	X _{REF} for fuselage C _w for wing C _v for vertical tail
	1 word	Y _{REF} for fuselage X _{LE} for wing X _{LE} for vertical tail
	1 word	Z _{REF} for fuselage X _{TE} for wing X _{TE} for vertical tail
	1 word	Not used for fuselage Z _{LE} for wing Not used for vertical tail
	1 word	Not used for fuselage Z _{TL} for wing Not used for vertical tail
4*NSEF words	1 word	X/L for fuselage at first C _p position Y/B _w for wing at first C _p position Z/B _v for vertical tail at first C _p position
	1 word	φ for fuselage at first C _p position X/C _w for wing at first C _p position X/C _v for vertical tail at first C _p position
	1 word	θ in radians for fuselage at first C _p position α for incidence angle in degrees for wing at first C _p position Not used for vertical tail

ORIGINAL PAGE IS
OF POOR QUALITY

USER MODEL FILE - Continued

FORMAT - Continued

AERCDYNAMIC INFORMATION TABLE - Continued

		<u>Description</u>
4*NSET words (conc.)	1 word	R for radius of fuselage at first C_p position Ω for dihedral angle in degrees for wing at first C_p position Not used for vertical tail
	:	:
	:	:
3*NSC+1 words	1 word	X/L for fuselage at last C_p position Y/B_w for wing at last C_p position Z/B_v for vertical tail at last C_p position
	1 word	ϕ for fuselage at last C_p position X/C_w for wing at last C_p position X/C_v for vertical tail at last C_p position
	1 word	θ in radians for fuselage at last C_p position α for incidence angle in degrees for wing at last C_p position Not used for vertical tail
	1 word	R for radius of fuselage at last C_p position Ω for dihedral angle in degrees for wing at last C_p position Not used for vertical tail
	1 word	Not used for fuselage NSC for number of sections taken along wing NSC for number of sections taken along vertical tail
	1 word	Not used for fuselage C_l for chord for first section along wing C_l for chord for first section along vertical tail
	1 word	Not used for fuselage S_l for span along wing to first section S_l for span along vertical tail to first section

USER MODEL FILE - Continued

FORMAT - Continued

AERODYNAMIC INFORMATION TABLE - Concluded

		<u>Description</u>
3*NSC+1 words (conc.)	1 word	Not used for fuselage X for value to front edge of flap at first section along wing (= 0 if not applicable) X for value to front edge of rudder at first section along vertical tail (= 0 if not applicable)
	.	.
	.	.
	.	.
	1 word	Not used for fuselage C_{ℓ} for chord for last section along wing C_{ℓ} for chord for last section along vertical tail
1 word	Not used for fuselage S_{ℓ} for span along wing to last section S_{ℓ} for span along vertical tail to last section	
1 word	Not used for fuselage X for value to front edge of flap at last section along wing (= 0 if not applicable) X for value to front edge of rudder at last section along vertical tail (= 0 if not applicable)	

ORIGINAL PAGE IS
OF POOR QUALITY

USER MODEL FILE - Continued

FORMAT - Continued

LOGICAL RECORD LAYOUT FOR GRID POINT/ C_p POSITION-COORDINATE DATA

		<u>Description</u>
NSET words	1 word	<u>Grid point</u> <u>C_p position</u> number of first <u>grid point</u> <u>C_p position</u> in substructure (NGP)
	.	.
	.	.
3*NSET words	1 word	<u>Grid point</u> <u>C_p position</u> number of last NSET <u>grid point</u> <u>C_p position</u> in substructure
	1 word	X-coordinate of first <u>grid point</u> <u>C_p position</u> in substructure
	1 word	Y-coordinate of first <u>grid point</u> <u>C_p position</u> in substructure
	1 word	Z-coordinate of first <u>grid point</u> <u>C_p position</u> in substructure
	.	.
	.	.
	.	.
	1 word	X-coordinate of last NSET <u>grid point</u> <u>C_p position</u> in substructure
	1 word	Y-coordinate of last NSET <u>grid point</u> <u>C_p position</u> in substructure
	1 word	Z-coordinate of last NSET <u>grid point</u> <u>C_p position</u> in substructure

Each logical record of grid point C_p position-coordinate data has a maximum word size of 560 words, which equal 140 grid point-coordinate sets.

USER MODEL FILE - Continued

FORMAT - Continued

ELEMENT HEADER BLOCK

Maximum length of this block is 28 words (1 sector).

		<u>Description</u>	
NTELE+1 words	1 word	Number of elements in the substructure (NELT) 1-18	Number of types of elements in the substructure (NTELE) (program documentation will contain type codes) 19-36
	1 word	First element type [†] 1-18	Pointer (sector count) to elements of this type 19-36
	.	.	.
	.	.	.
	1 word	Last NTELE element type [†] 1-18	Pointer (sector count) to elements of this type 19-36
	X [†] words	Spare	

[†]For element type code, refer to the following table.

Number of spare words (X) = 27 - NTELE

Type Code	Element Identification	NASTRAN Bulk Data ID
1	Simple beam element	CBAR
2	Rod element	CONROD
3	Tension-compression-torsion element (ROD)	CROD
4	Tension-compression-torsion element (TUBE)	CTUBE
5	Quadrilateral membrane element	CQDMEM
6	Isoparametric quadrilateral element	CQDMEM1
7	Quadrilateral membrane element	CQDMEM2
8	Quadrilateral element connection	CQDPLT
9	Quadrilateral membrane and bending element	CQUAD1
10	Homogeneous quadrilateral membrane and bending element	CQUAD2
11	Shear panel element	CSHLAR
12	Triangular membrane and bending element	CTRIA1
13	Triangular element	CTRIA2
14	Triangular membrane element	CTRMEM
15	Triangular bending element	CTRPLT

ORIGINAL PAGE IS
OF POOR QUALITY

USER MODEL FILE - Continued

FORMAT - Continued

ELEMENT IDENTIFICATION TABLE

Maximum logical record size is 560 words. The indicator bits will be present only if the NASTRAN elements have optional data. NFIELD is the total number of six-bit indicators required by an element.

		<u>Description</u>					
Number of words [‡]	1 word	Number of elements of first element type in substructure					
	1 word	Element ID number of first element of this type in substructure					
	1 word	First required connection specification [†]					
	⋮	⋮					
	1 word	Last required connection specification [†]					
NFIELD words	1 word	Indicator number 1	Indicator number 2	Indicator number 3	+		
		1-6	7-12	13-18	19-24	25-30	31-36
	1 word	Indicator number 7			+		Indicator number 12
		1-6	7-12	13-18	19-24	25-30	31-36
	⋮	⋮	⋮	⋮	⋮	⋮	⋮
	⋮	⋮	⋮	⋮	⋮	⋮	⋮
	1 word	Indicator number NFIELD			+		
		1-6	7-12	13-18	19-24	25-30	31-36
	1 word	Data value corresponding to indicator number 1 above					
	1 word	Data value corresponding to indicator number 2 above					
	1 word	Data value corresponding to indicator number 3 above					
	⋮	⋮					
1 word	Data value corresponding to indicator number NFIELD above						

[†]For explanation of these words refer to descriptions of individual element types in the NASTRAN User's Guide.

[‡]Number of words equals 1 if 1 ≤ NF ≤ 6, equals 2 if 7 ≤ NF ≤ 12, equals 3 if 13 ≤ NF ≤ 18, etc.

USER MODEL FILE - Continued

FORMAT - Continued

ELEMENT IDENTIFICATION TABLE - Concluded

Description

1 word	Element ID number of next element of the element type continued from previous logical record																								
1 word	First required connection specification																								
.	.																								
.	.																								
1 word	<table border="1" style="width: 100%; border-collapse: collapse;"> <thead> <tr> <th style="text-align: center;">Indicator number</th> <th style="text-align: center;">Indicator number</th> <th style="text-align: center;">Indicator number</th> <th style="text-align: center;">Indicator number</th> <th style="text-align: center;">Indicator number</th> <th style="text-align: center;">Indicator number</th> </tr> </thead> <tbody> <tr> <td style="text-align: center;">1-6</td> <td style="text-align: center;">7-12</td> <td style="text-align: center;">13-18</td> <td style="text-align: center;">19-24</td> <td style="text-align: center;">25-30</td> <td style="text-align: center;">31-36</td> </tr> <tr> <td style="text-align: center;">.</td> <td style="text-align: center;">.</td> <td style="text-align: center;">.</td> <td style="text-align: center;">.</td> <td style="text-align: center;">.</td> <td style="text-align: center;">.</td> </tr> <tr> <td style="text-align: center;">.</td> <td style="text-align: center;">.</td> <td style="text-align: center;">.</td> <td style="text-align: center;">.</td> <td style="text-align: center;">.</td> <td style="text-align: center;">.</td> </tr> </tbody> </table>	Indicator number	Indicator number	Indicator number	Indicator number	Indicator number	Indicator number	1-6	7-12	13-18	19-24	25-30	31-36
Indicator number	Indicator number	Indicator number	Indicator number	Indicator number	Indicator number																				
1-6	7-12	13-18	19-24	25-30	31-36																				
.																				
.																				
.																									
.																									
1 word	Data value corresponding to indicator number FIELD																								

ORIGINAL PAGE IS
OF POOR QUALITY

USER MODEL FILE - Continued

FORMAT - Continued

COORDINATE SYSTEM IDENTIFICATION TABLE

		<u>Description</u>				
	1 word	Number of coordinate systems defined for substructure (NCID)				
	1 word	<table border="1" style="width: 100%;"> <tr> <td style="width: 50%;">Number of grid points defined using this coordinate system (NGPC₁)</td> <td style="width: 50%;">Coordinate system identification number</td> </tr> <tr> <td style="text-align: center;">1-18</td> <td style="text-align: center;">19-36</td> </tr> </table>	Number of grid points defined using this coordinate system (NGPC ₁)	Coordinate system identification number	1-18	19-36
Number of grid points defined using this coordinate system (NGPC ₁)	Coordinate system identification number					
1-18	19-36					
NGPC ₁ words	1 word	Grid point number				
	1 word	Grid point number				
	.	.				
	.	.				
	1 word	Grid point number				
	1 word	Code for type [†] of coordinate system (refer to coordinate system notes in <i>NASTRAN User's Guide</i> for definition of type of coordinate system).				
N words	1 word	Data for coordinate system definition [‡]				
	.	.				
	.	.				
	1 word	Data for coordinate system definition [‡]				
	1 word	<table border="1" style="width: 100%;"> <tr> <td style="width: 50%;">Number of grid points defined using this coordinate system (NGPC_N)</td> <td style="width: 50%;">Coordinate system identification number</td> </tr> <tr> <td style="text-align: center;">1-18</td> <td style="text-align: center;">19-36</td> </tr> </table>	Number of grid points defined using this coordinate system (NGPC _N)	Coordinate system identification number	1-18	19-36
Number of grid points defined using this coordinate system (NGPC _N)	Coordinate system identification number					
1-18	19-36					

[†]For coordinate system type code refer to this table format description.

[‡]Refer to coordinate system notes in the *NASTRAN User's Guide* for the number and meaning of the data words required to define the coordinate system.

USER MODEL FILE - Continued

FORMAT - Continued

COORDINATE SYSTEM IDENTIFICATION TABLE - Concluded

NGPCN words	}	1 word	Grid point number
		1 word	Grid point number
		.	.
		.	.
M words	}	1 word	Grid point number
		1 word	Code for type of coordinate system (refer to coordinate system notes)
		1 word	Data for coordinate system definition [†]
		.	.
		1 word	Data for coordinate system definition [†]

[†]Refer to coordinate system notes in *NASTRAN User's Guide* for the number and meaning of the data words required to define the coordinate system.

COORDINATE SYSTEM TYPE CODE TABLE

Type Code	Description	NASTRAN Card Type
1	Cylindrical coordinate system definition	CORD1C
2	Rectangular coordinate system definition	CORD1R
3	Spherical coordinate system definition	CORD1S
4	Cylindrical coordinate system definition	CORD2C
5	Rectangular coordinate system definition	CORD2R
6	Spherical coordinate system definition	CORD2S

ORIGINAL PAGE IS
OF POOR QUALITY

USER MODEL FILE - Continued

FORMAT - Continued

ADDITIONAL SURFACE DEFINITION DATA

Description

9*NGP per substructure	3 words	Direction cosine of normal with respect to X, Y, and Z axes of first grid point in substructure
	3 words	Tangent of curve with respect to X, Y, and Z axes
	3 words	Tangent of stringer with respect to X, Y, and Z axes of first grid point in substructure
	3 words	Direction cosine of normal with respect to X, Y, and Z axes of second grid point in substructure
	3 words	Tangent of curve with respect to X, Y, and Z axes of second grid point in substructure
	3 words	Tangent of stringer with respect to X, Y, and Z axes of second grid point in substructure
	.	.
	3 words	Tangent of stringer with respect to X, Y, and Z axes of last NGP grid point in substructure

USER MODEL FILE - Continued

FORMAT - Continued

CELL IDENTIFICATION TABLE FOR ELEMENTS

		<u>Description</u>	
NTELE words	1 word	First element type 1-18	Pointer (sector count) to Cell Identification Table for first element type 19-36
	1 word	Second element type 1-18	Pointer (sector count) to Cell Identification Table for second element type 19-36
	.	.	.
	.	.	.
	1 rd	Last NTELE element type 1-18	Pointer (sector count) to Cell Identification Table for last NTELE element type 19-36

Cell Identification Table Format for Each Element Type Within a Substructure

		<u>Description</u>	
5 words	1 word	Element ID number of first element of this type in substructure	
	1 word	First cell ID number of first element of this type 1-18	Second cell ID number of first element of this type 19-36
	1 word	X-coordinate of center of first element in substructure	
	1 word	Y-coordinate of center of first element in substructure	
	1 word	Z-coordinate of center of first element in substructure	

USER MODEL FILE - Continued

FORMAT - Continued

CELL IDENTIFICATION TABLE FOR ELEMENTS - Concluded

Cell Identification Table Format for Each Element Type Within a Substructure - Concluded

		<u>Description</u>				
5 words	1 word	Element ID number of second element of this type in substructure				
	1 word	<table border="1" style="width: 100%; border-collapse: collapse;"> <tr> <td style="padding: 2px;">First cell ID number of second element of this type</td> <td style="padding: 2px;">Second cell ID number of second element of this type</td> </tr> <tr> <td align="center">1-18</td> <td align="center">19-36</td> </tr> </table>	First cell ID number of second element of this type	Second cell ID number of second element of this type	1-18	19-36
	First cell ID number of second element of this type	Second cell ID number of second element of this type				
	1-18	19-36				
	1 word	X-coordinate of center of second element in substructure				
1 word	Y-coordinate of center of second element in substructure					
1 word	Z-coordinate of center of second element in substructure					
	⋮					
5 words	1 word	Element ID number of last element of this type in substructure				
	1 word	<table border="1" style="width: 100%; border-collapse: collapse;"> <tr> <td style="padding: 2px;">First cell ID number of last element of this type</td> <td style="padding: 2px;">Second cell ID number of last element of this type</td> </tr> <tr> <td align="center">1-18</td> <td align="center">19-36</td> </tr> </table>	First cell ID number of last element of this type	Second cell ID number of last element of this type	1-18	19-36
	First cell ID number of last element of this type	Second cell ID number of last element of this type				
	1-18	19-36				
	1 word	X-coordinate of center of last element in substructure				
1 word	Y-coordinate of center of last element in substructure					
1 word	Z-coordinate of center of last element in substructure					

USER MODEL FILE - Concluded

FORMAT - Concluded

NODAL DESCRIPTION DATA

		<u>Description</u>
3*NSET words	3 words	Grid point description for first grid point
	3 words	Grid point description for second grid point
	.	.
	3 words	Grid point description for last grid point

**ORIGINAL PAGE IS
OF POOR QUALITY**

VADIC OUTPUT FILE

GENERAL

This data file, generated by the batch program VADIC, will be used to supply ambient pressure, dynamic pressure, and compartment pressure to ISAS.

Type of interface: I

Interface medium: Random access mass storage

Output method: NTRAN

Created by: Venting Analysis (VADIC)

Modified by: None

Used by: Force Inputs to Internal Loads Analysis,
Venting Analysis

PURPOSE OF INTERFACE

For selected flight times, this data file will contain pressure data and will be used as a common source for this type of data.

CONFIGURATION CONSTRAINTS

The file can contain data for a maximum of 56 compartments.

VADIC OUTPUT FILE – Concluded

FORMAT

		<u>Type</u>	<u>Description</u>
Header Block	24 words	A	File title
	1 word	I	Number of compartments (NCDUM) [†]
	NCDUM words	I	Compartment ID numbers
	1 word	R	First time on file (seconds)
	1 word	R	Last time on file (seconds)
	1 word	R	Time increment (seconds)
Time Block [‡]	1 word	R	Time (seconds)
	1 word	R	Ambient pressure
	1 word	R	Dynamic pressure
	NCDUM words	R	Compartment pressures

[†]Maximum size of NCDUM is 56 compartments.

[‡]Time blocks always start in word 1 of a sector.

**ORIGINAL PAGE IS
OF POOR QUALITY**

WINDS ALOFT DATA FILE

TBD