

NASA TECHNICAL NOTE

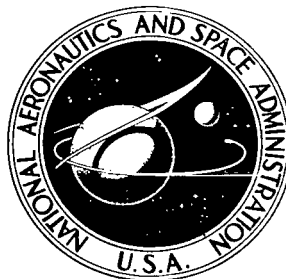

NASA IN D-8209 *el*

NASA TN D-8209



**LOAN COPY: RETURN TO
AFWL TECHNICAL LIBRARY
KIRTLAND AFB, N. M.**

**PRACTICAL ASPECTS OF USING A MAXIMUM
LIKELIHOOD ESTIMATION METHOD
TO EXTRACT STABILITY AND CONTROL
DERIVATIVES FROM FLIGHT DATA**

Kenneth W. Iliff and Richard E. Maine

Dryden Flight Research Center

Edwards, Calif. 93523





0133768

1. Report No. NASA TN D-8209		2. Government Accession No.		3. Rept. No. 0133768	
4. Title and Subtitle PRACTICAL ASPECTS OF USING A MAXIMUM LIKELIHOOD ESTIMATION METHOD TO EXTRACT STABILITY AND CONTROL DERIVATIVES FROM FLIGHT DATA				5. Report Date April 1976	
7. Author(s) Kenneth W. Iliff and Richard E. Maine				6. Performing Organization Code	
9. Performing Organization Name and Address NASA Dryden Flight Research Center P.O. Box 273 Edwards, California 93523				8. Performing Organization Report No. H-908	
12. Sponsoring Agency Name and Address National Aeronautics and Space Administration Washington, D.C. 20546				10. Work Unit No. 512-53-03	
15. Supplementary Notes A condensed version of this report is included in AGARD-CP-172, May 1975.				11. Contract or Grant No.	
16. Abstract This paper discusses the application of a maximum likelihood estimation method (sometimes referred to as the Newton-Raphson method) to flight data and describes procedures to facilitate the routine analysis of a large amount of flight data. Flight data are used to illustrate the procedures described. Techniques that can be used to obtain stability and control derivatives from aircraft maneuvers that are less than ideal for this purpose are described. The techniques involve detecting and correcting the effects of dependent or nearly dependent variables, structural vibration, data drift, inadequate instrumentation, and difficulties with the data acquisition system and the mathematical model. The use of uncertainty levels and multiple maneuver analysis also proved to be useful in improving the quality of the estimated coefficients. The procedures used for editing the data and for overall analysis are also discussed.				13. Type of Report and Period Covered Technical Note	
17. Key Words (Suggested by Author(s)) Identification Parameter estimation Maximum likelihood estimation Stability and control derivatives Flight data analysis				14. Sponsoring Agency Code	
19. Security Classif. (of this report) Unclassified		20. Security Classif. (of this page) Unclassified		21. No. of Pages 32	
18. Distribution Statement Unclassified - Unlimited Category: 08				22. Price* \$3.75	

*For sale by the National Technical Information Service, Springfield, Virginia 22161

PRACTICAL ASPECTS OF USING A MAXIMUM LIKELIHOOD
ESTIMATION METHOD TO EXTRACT STABILITY AND CONTROL
DERIVATIVES FROM FLIGHT DATA

Kenneth W. Iliff and Richard E. Maine
Dryden Flight Research Center

INTRODUCTION

The extraction of stability and control derivatives from flight data has been of interest for many years. The derivatives are used to provide final verification of the predicted full-scale aircraft aerodynamic characteristics and for the verification of prediction techniques. The derivatives are needed to improve vehicle design and to assist in the flight testing and verification of overall aircraft system performance. After the analysis of the flight test data, the aircraft stability and control characteristics can be compared with calculated derivatives and wind tunnel predictions, and this comparison can be used to update prediction methods for the improvement of future aircraft designs. Once an aircraft is built, the derivatives play an important role in the expansion of the flight test envelope. As estimates of the derivatives become available, they are used to upgrade fixed-base simulators to assist in flight planning and the modification of the aircraft control system. In addition, the flight-determined derivatives can be used to assess compliance with the desired design specifications. Stability and control derivatives are also used to establish the accuracy of airborne simulations and to identify aircraft parameters for adaptive control.

Automating the means of obtaining stability and control derivatives can improve the efficiency of flight testing and provide a more consistent set of flight-estimated derivatives. To attain these objectives, in 1966 the Dryden Flight Research Center started to develop a digital nonlinear minimization program for derivative extraction. The maximum likelihood estimation program (sometimes referred to as the Newton-Raphson program, as in refs. 1 and 2) evolved from that effort.

Some investigators maintain that the maximum likelihood estimation method is not practical for routine use on a large quantity of flight data. With certain qualifications, it has been found that most difficulties arise from modeling or data problems and that these difficulties can be isolated and, in some instances, accounted for.

This paper discusses the Dryden Flight Research Center's experience with the maximum likelihood estimation method, with emphasis on derivative extraction in a batch processing mode. Although the report deals with the digital computer program developed at the Dryden Flight Research Center, much of the discussion applies to any maximum likelihood estimation program with the same basic options. The paper also describes analytical techniques that can be applied to flight data to increase the usefulness of the data or to provide additional insight into the meaning of the estimates obtained.

SYMBOLS

A	stability matrix
a_n	normal acceleration, g
a_x	longitudinal acceleration, g
a_y	lateral acceleration, g
B	control matrix
$C_{D_{trim}}$	coefficient of drag at trim condition
$C_{L_{trim}}$	coefficient of lift at trim condition
C_m	pitching-moment coefficient
C_{m_α}	coefficient of partial derivative of pitching moment with respect to angle of attack, per deg
C_{n_p}	coefficient of partial derivative of yawing moment with respect to roll rate, per rad
C_{Y_β}	coefficient of partial derivative of side force with respect to angle of sideslip, per deg
C_{Z_α}	coefficient of partial derivative of normal force with respect to angle of attack, per deg
c	vector of unknown coefficients
c_0	vector of <i>a priori</i> estimates of unknown coefficients
D_1	weighting matrix for observation vector

D_2	weighting matrix for <i>a priori</i> estimate vector
G	partition of matrix relating state vector to observation vector
g	acceleration due to gravity, m/sec ² (ft/sec ²)
H	partition of matrix relating control vector to observation vector
I	identity matrix
I_X	moment of inertia about roll axis, kg-m ² (slug-ft ²)
I_{XZ}	cross moment of inertia between roll and yaw axes, kg-m ² (slug-ft ²)
I_Y	moment of inertia about pitch axis, kg-m ² (slug-ft ²)
I_Z	moment of inertia about yaw axis, kg-m ² (slug-ft ²)
J	cost functional
K	scale weighting factor for <i>a priori</i> weighting matrix
L_β	dihedral effect, per sec
n	measurement noise vector
p	roll rate, deg/sec or rad/sec
q	pitch rate, deg/sec
R	acceleration transformation matrix
r	yaw rate, deg/sec or rad/sec
T	total observation time, sec
t	intermediate or incremental time, sec
u	control vector
V	velocity, m/sec (ft/sec)
v	variable bias vector for nonstate measurements
x	state vector
y	calculated observation vector

z	measurement of observation vector
α	angle of attack, deg or rad
α_{gust}	angle of attack due to gust, deg
α_m	measured angle of attack, deg
α_0	angle of attack of principal axis, deg or rad
β	angle of sideslip, deg or rad
δ_a	aileron deflection, deg
δ_e	elevator deflection, deg
δ_r	rudder deflection, deg
θ	pitch angle, deg or rad
$\rho(\bullet)$	probability density function of (\bullet)
φ	bank or roll angle, deg or rad
$\mathbf{0}$	null matrix

Subscript:

b referenced to body axis

Superscripts:

$*$ matrix transpose

\bullet derivative with respect to time

MAXIMUM LIKELIHOOD ESTIMATION METHOD

The maximum likelihood estimation method is one technique that can be used to estimate aircraft stability and control derivatives from flight maneuvers.

The equations that are used to describe an aircraft system in the maximum likelihood estimation method are as follows:

$$R\dot{x}(t) = Ax(t) + Bu(t)$$

$$y(t) = \begin{bmatrix} I \\ G \end{bmatrix} x(t) + \begin{bmatrix} 0 \\ H \end{bmatrix} u(t) + \begin{bmatrix} 0 \\ v \end{bmatrix} \quad (1)$$

$$z(t) = y(t) + n(t)$$

where the unknown coefficients of the system appear in the A , B , G , and H matrices, the vector v , and the initial state vector $x(0)$. All the unknown coefficients can be considered to form a vector c .

The maximum likelihood estimates of the unknown coefficients, c , are obtained by minimizing the following cost functional with respect to c :

$$J = \frac{1}{T} \int_0^T \left[z(t) - y(t) \right]^* D_1 \left[z(t) - y(t) \right] dt \quad (2)$$

If $n(t)$ in equation (1) is Gaussian white noise and the weighting matrix D_1 is the inverse of the measurement noise covariance matrix, the minimization results in the maximum likelihood estimates. The controls are assumed to be known and noiseless.

Figure 1 illustrates the maximum likelihood estimation concept. The response of the aircraft measured in flight can be compared with the response computed on the basis of the mathematical model of the airplane. The difference between these responses is called the response error. The likelihood functional is then maximized with the modified Newton-Raphson computational algorithm, providing a new

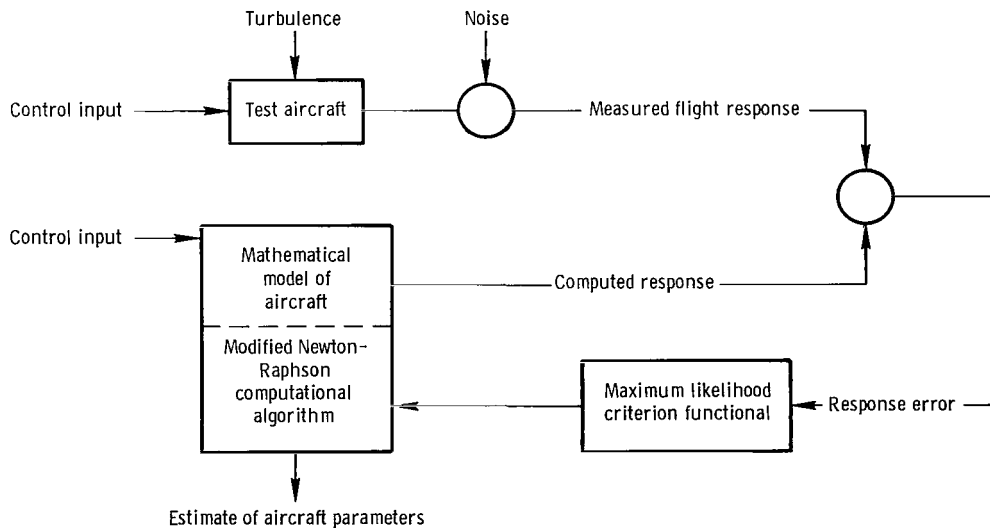

Figure 1. Maximum likelihood estimation concept.

estimate of the unknown coefficients on the basis of the response error. These unknown coefficients are then used to update the mathematical model of the aircraft. The updated mathematical model is used to provide a new computed response and therefore a new response error. The updating of the mathematical model continues iteratively until the response error satisfies some convergence criterion. This procedure for estimating the unknown coefficients is called the maximum likelihood estimation method. It is described more fully in reference 2.

Independent estimates of the unknown coefficients are often available from wind tunnel data, previously obtained flight data, or calculated derivatives. It is desirable to use this *a priori* information in conjunction with the maximum likelihood estimation method so that all available information is used to obtain the estimates. No change is made in the derivatives from the *a priori* values unless there is sufficient information in the flight data to justify a change. This feature can be incorporated in the technique by expanding the cost functional to include a penalty for departing from the *a priori* values. With this feature, the technique is referred to as the modified maximum likelihood estimation method, and it is implemented by minimizing the following cost functional with respect to the vector of unknown coefficients, c :

$$J = \frac{1}{T} \int_0^T \left\{ [z(t) - y(t)]^* D_1 [z(t) - y(t)] \right\} dt + (c - c_0)^* KD_2 (c - c_0) \quad (3)$$

where c_0 is the vector of *a priori* estimates of the vector c and KD_2 is the weighting matrix for the *a priori* information. This cost functional can be derived in the same way as that for the maximum likelihood estimator by using the joint probability, $\rho(z, c)$, instead of the conditional probability, $\rho(z/c)$. The modified maximum likelihood estimation method is discussed in greater detail in references 1 and 2.

DESCRIPTION OF DRYDEN FLIGHT RESEARCH CENTER COMPUTER PROGRAM

The maximum likelihood estimation method is used routinely at the Dryden Flight Research Center to extract stability and control derivatives from flight data. Three FORTRAN programs are used to implement the technique. The first program, called the SETUP program, automates data handling and preparation for analysis; the second, the MMLE program, contains the modified maximum likelihood estimation algorithm; and the third, the SUMMARY program, provides a way to display and summarize the results. Figure 2 summarizes the relationship of these programs in the extraction process.

The SETUP program automatically determines the appropriate flight condition and the necessary startup values from the flight data for use in the second program. The SETUP program punches a startup card deck and creates a file containing the flight's time history. Each of these automatic features can be overridden. Only the following information is absolutely necessary for analyzing a maneuver: the start and stop time for each maneuver; the quantities required for each maneuver, including flight condition; the geometric characteristics of the vehicle, including instrument locations; the nondimensional derivatives that are used as the starting

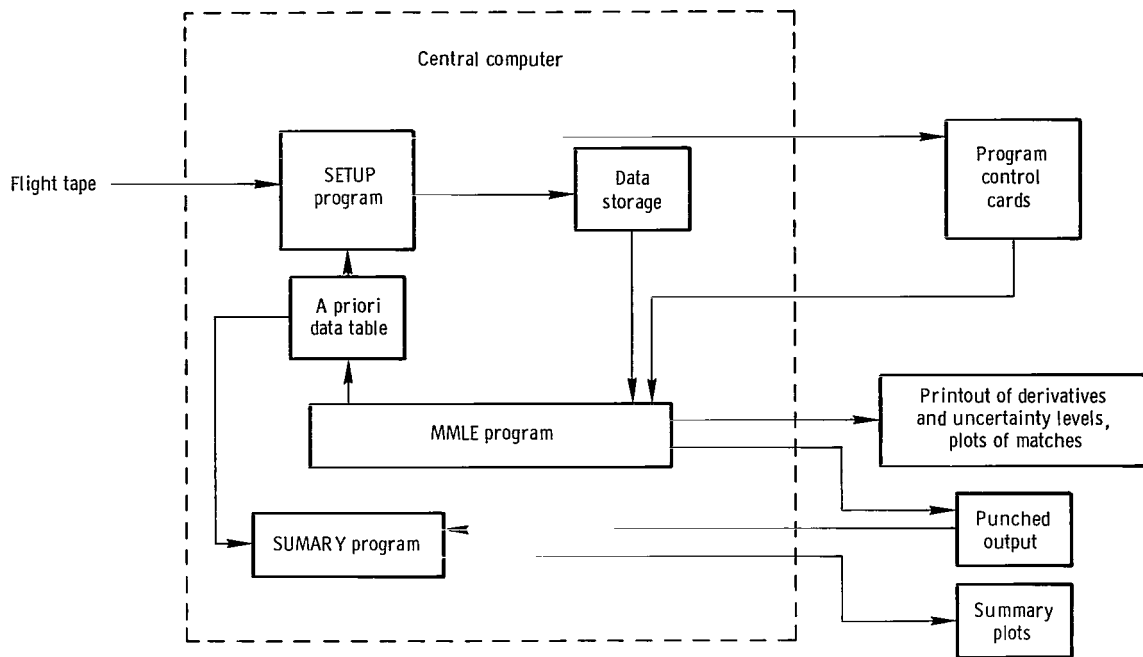

Figure 2. Relationship of SETUP, MMLE, and SUMMARY programs in estimation of stability and control derivatives from flight data.

values of the algorithm; and an indication as to which controls move independently during each maneuver.

The MMLE program provides estimates of the unknown coefficients in equation (1). The measured response vector usually consists of aircraft attitudes, angular rates, and linear accelerations. The aircraft equations are written with respect to arbitrary accelerometer locations so that they can be matched directly, without the need for corrections involving angular accelerations.

To use the MMLE program, the D_1 and D_2 matrices in equation (3) must be known. The matrices are usually determined from flight data that agree with data based on the mathematical model (*i.e.*, the matrices found when the response error is approximately equal to the measurement noise). The matrices should remain fixed until there is a major change in instrumentation. The program has a mode that determines the D_1 or the D_2 matrix or both. The D_1 matrix, which is assumed to be diagonal, is determined in such a way that the weighted error of each measurement is approximately unity. This is achieved by letting the algorithm converge to a solution, adjusting the elements in the D_1 matrix appropriately, and letting the algorithm converge with this new D_1 matrix. This procedure is repeated automatically until the weighted error of each measurement is within some tolerance of unity. Once the D_1 matrix has been determined, the elements in the D_2 matrix can be evaluated. The D_2 matrix, which is also assumed to be diagonal, is obtained by

allowing the algorithm to converge with a fixed D_2 matrix and various values of K (eq. (3)). Then each converged estimate is plotted as a function of K . The elements in the D_2 matrix can be adjusted so that all the coefficients start to deviate from the *a priori* estimates at approximately the same value of K . The D_1 and D_2 matrix determination is discussed in more detail in reference 2.

Three features in the MMLE program make it possible to modify the input data to account for errors or to specify changes in the model being used. First, the input measurements can be biased or multiplied by a constant, and angle of attack, angle of sideslip, and linear acceleration can be corrected for instrument location. Second, extra inputs can be made to add any information necessary to correct the model (a nonlinear function of one or more of the measured variables, for example). Finally, the time histories of maneuvers made at approximately the same flight condition can be analyzed simultaneously, resulting in one set of estimates.

The SUMMARY program provides plots of the estimated derivatives and uncertainty levels (proportional to Cramèr-Rao bounds, ref. 2) from the punched card output of the MMLE program. These derivatives are plotted as a function of angle of attack. The symbols can be designated to distinguish between Mach numbers, configurations, or other parameters of interest. *A priori* estimates (or any other estimates) can also be included in the plots.

A detailed description of the SETUP, MMLE, and SUMMARY programs is given in reference 3 along with complete FORTRAN listings and computer check cases.

DRYDEN FLIGHT RESEARCH CENTER EXPERIENCE

The Dryden Flight Research Center has been using the maximum likelihood estimation method to extract stability and control derivatives from flight data for 9 years. More than 2200 maneuvers, from 20 aircraft, have been successfully analyzed. The method was used routinely for 70 percent of these maneuvers. The flight conditions have included Mach numbers up to 5, altitudes up to 30,700 meters (100,000 feet), angles of attack from -20° to 53° , and normal accelerations up to $4g$. Virtually all the derivative extraction at the Dryden Flight Research Center is done with the modified maximum likelihood estimation program discussed in this paper.

The Dryden Flight Research Center's experience with maximum likelihood estimation derivative extraction is summarized in the following table. As the table shows, the data from nearly 100 percent of the maneuvers performed with the more conventional aircraft provide acceptable results. The percentage of maneuvers successfully analyzed is as low as 71 percent for the more experimental aircraft, with which it is more difficult to maintain a given set of flight conditions. Overall, 89 percent of the maneuvers were successfully analyzed. Most of the M2-F3 lifting body maneuvers that were not successfully analyzed were those during which unsteady transonic flow occurred. The low percentage of maneuvers successfully analyzed for the F-111A airplane is attributed to lateral-directional motion, which occurred during more than half of the longitudinal maneuvers performed at high normal accelerations. The lateral-directional variables were not recorded, so the

Aircraft	Number of maneuvers analyzed	Number of maneuvers successfully analyzed	Maneuvers successfully analyzed, percent
X-15	Unknown	10 ^a	---
XB-70	Unknown	30 ^a	---
M2-F2	Unknown	5 ^a	---
HL-10	Unknown	75 ^a	---
M2-F3	155	110	71
X-24A	Unknown	15 ^a	---
F-111A	Unknown	10 ^a	---
CV-990	90	90	100
F-8 (supercritical wing)	320	260	81
YF-12	30	30	100
F-8C	11	10	91
JetStar	352	343	97
F-111A	181	150	83
F-111A (transonic aircraft technology)	324	288	89
X-24B	161	148	92
F-15 (3/8-scale model)	168	136	81
PA-30	214	213	99
YT-2B	15	11	73
YF-16	33	32	97
T-37B	166	162	98

^aRounded to the nearest 5.

effect of cross coupling on the longitudinal mode could not be corrected for on this airplane. The 3/8-scale model of the F-15 airplane experienced buffet at angles of attack between 20° and 35°, and this accounts for most of the unsuccessfully analyzed maneuvers. For longitudinal maneuvers of average length, approximately 20 seconds of CDC 6500 computer time are necessary per submittal, and for lateral-directional maneuvers approximately 40 seconds are necessary. In this context, a submittal refers to submitting a maneuver for processing or to resubmitting a maneuver for

processing or for additional analysis after changes have been made to the procedure to improve the derivative extraction process.

In general, the use of the maximum likelihood estimation method to extract derivatives has been very successful. Most of the resulting fits were nearly perfect, particularly when the percentage of maneuvers successfully analyzed was high. Recently, 86 maneuvers performed during a flight of the PA-30 airplane, during which the airplane was in three different configurations, were analyzed in the batch processing mode. After the flight, the data were stripped out on a Sanborn recorder and the maneuver times were read off. The raw data were in pulse code modulation (PCM) form in engineering units. A typical lateral-directional maneuver was 10 seconds long, and a typical longitudinal maneuver was 6 seconds long. The entire derivative extraction process, including the creation of the original data files and the summary plots of the derivatives for the three PA-30 configurations throughout the angle of attack range, required only 12 engineering hours and 1.75 hours of CDC 6500 computer time. Eighty-five of the 86 maneuvers were successfully analyzed; therefore, each maneuver required less than 9 minutes of engineering time and approximately 1.25 minutes of computer time. These results are typical for maneuvers analyzed under ideal conditions.

Data acquired for the unpowered, remotely piloted 3/8-scale model of the F-15 airplane exemplify data obtained under difficult conditions. Twenty-five stability and control maneuvers, covering an angle of attack range from -20° to 38° , were performed during two flights. The maneuvers required much more careful analysis because the vehicle was unpowered and at extreme angles of attack, and the flight conditions changed quickly. The entire derivative extraction process required 9.25 engineering hours and 1.25 hours of CDC 6500 computer time. Twenty-two of the 25 maneuvers were successfully analyzed; therefore, each maneuver required approximately 22 minutes of engineering time and 3 minutes of computer time, more than twice as much time as was necessary for the analysis of the PA-30 data.

For data of high quality, such as those for the PA-30 airplane, the average maneuver required fewer than 1.2 submittals per maneuver. Data obtained when flight conditions were difficult to maintain, as when the F-111A airplane performed elevated normal acceleration maneuvers or the 3/8-scale F-15 remotely piloted research vehicle performed maneuvers at high angles of attack, 2.3 submittals per maneuver were required. When a maneuver is marginal for analysis purposes, when the derivative estimates are important because only one maneuver is available, or when the estimates are needed before further flight envelope expansion, five or six submittals may be desirable.

IMPROVING QUALITY OF ESTIMATES

Although the use of the maximum likelihood estimation method has in general been successful at the Dryden Flight Research Center, difficulties have been encountered in analyzing from 10 percent to 15 percent of the maneuvers. These maneuvers required more extensive analysis before good estimates of the stability and control derivatives were obtained from them.

Sometimes no estimates, or only poor estimates, of the unknown coefficients could be obtained. This was occasionally the result of applying the maximum likelihood estimation method carelessly even though the standard mathematical model (ref. 3) was valid. Certain other situations also affect the derivative extraction process, and if they are avoided or identified, the estimation process can proceed routinely.

Dependent Variables

One reason that poor estimates result is that the set of unknown coefficients is not completely independent. Dependence is most common in the aerodynamic and instrument biases. If the two sets of biases are not linearly independent, the estimates of the biases are obviously meaningless. Although linearly dependent biases usually have little effect on the estimates of the stability and control derivatives, they can slow the convergence of the algorithm. Of course, the determination of too few biases can result in significant errors in the stability and control derivatives. When both aerodynamic and instrument biases exist, one safe way to choose these biases is to permit the aerodynamic biases to vary for each state being fit and the instrument biases to vary only for the nonstate measurements, such as the accelerometer measurements. This insures a linearly independent set of biases.

Another type of linear dependence occurs when a vehicle operates with the stability augmentation system on and the controls in the augmentation system are not used independently to make control inputs. An independent input is always preferable. The implementation of the stability augmentation system results in one of the control variables being nearly dependent on the state variable being fed back. This can be overcome by not allowing the derivatives of the control in question to vary. Of course, the control is only nearly dependent on the state, because several electrical and mechanical devices must be engaged before the state measurement can affect the control. Usually this near dependence results in poor estimates of several of the derivatives if these control derivatives are allowed to vary.

Another kind of dependence occurs when two controls, such as an interconnected aileron and spoiler, move together throughout most of the command range. Usually this is best dealt with by using the average deflection of the two controls and estimating one set of control derivatives for both. Sometimes the effect of one of the controls is much greater than that of the other. In this instance, the derivative should be determined with respect to the more effective control, and the derivatives with respect to the other control should be fixed.

In cases of linear dependence or near linear dependence, *a priori* weighting, with the weighting somewhat higher on the derivatives of the nearly dependent variables than on the derivatives of the independent variables, has been used with some success. This approach can sometimes be successful in apportioning the values of the dependent derivatives, particularly when stability augmentation is used.

Structural Vibration

All aircraft have observable modes of structural vibration. They usually cause no difficulty because their frequencies are high compared with the aerodynamic frequencies. In general, if the structural frequencies are more than a factor of 5 or 10 higher than the highest aerodynamic frequency, they can be neglected unless they interfere with control position measurements. The estimates of the derivatives are usually unaffected by high-frequency structural vibration. However, if the structural frequency is near the aerodynamic frequency, three approaches can be taken to account for it. If the characteristics of the structural mode are known or can be determined by using other techniques, such as power spectral analysis, their effect can be removed from the data before the derivatives are extracted. A second and more difficult approach is to model the structural modes as well as the aerodynamic modes and then to estimate the unknown coefficients for all the modes. This does not require any modification of the theory of maximum likelihood estimation but may require significant modification to specific maximum likelihood estimation computer programs. The third method is to analyze the data as if the structural modes were not there and to determine a set of equivalent coefficients reflecting the effects of the structural modes.

If it is felt that structural vibrations are interfering with the vehicle response computation, the power spectra of the control measurement can be determined. The frequency of the structural vibration can then be identified. If the structural frequency is much higher than the aerodynamic frequencies, it can be filtered out of the raw data with a notch digital filter. It is usually desirable to filter all the measurements with the same filter. Structural vibration should always be excluded from control measurements, because the maximum likelihood estimation method is based on the assumption that the control input measurements are noiseless.

Drift

Drift in the states, which is caused by the small vehicle nonlinearities that sometimes result from unsteady aerodynamics or the variation of the flight condition, is another type of problem. Usually drift causes no particular problem, since a maneuver need only be shortened to improve the analysis. However, when there is more than one sharp control input, the adverse effects of drift become significant. Figure 3(a) compares data measured for aileron and rudder control inputs with data computed from estimated derivatives. As the figure shows, drift was significant before any rudder input was made. The algorithm attempted to match the time history during the rudder input, but was unable to compensate for the drift, and the resulting rudder derivatives are poor.

This problem can be overcome by treating a maneuver as two separate maneuvers and reinitializing the algorithm just before the sharp control input is made. This technique, referred to as multiple maneuver analysis, results in no significant error in the states at the time of the input. In multiple maneuver analysis, the A and B matrices are assumed to be identical for each maneuver. Figure 3(b) shows the fit obtained from the data in figure 3(a) when multiple maneuver analysis was used. The fit is excellent and results in good rudder derivatives. This procedure can be used to delete data that do not change appreciably with time. The multiple

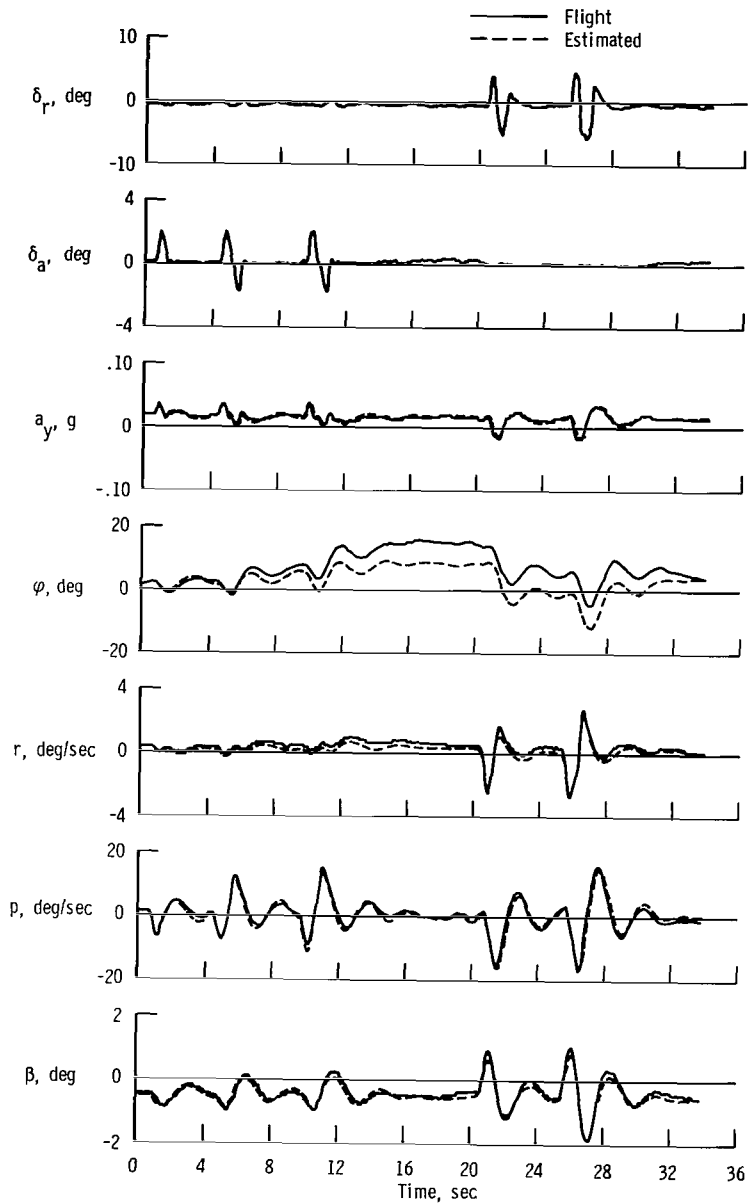

(a) Single maneuver analysis.

Figure 3. Fit of computed and flight data for single and multiple maneuver analysis when drift effects are evident.

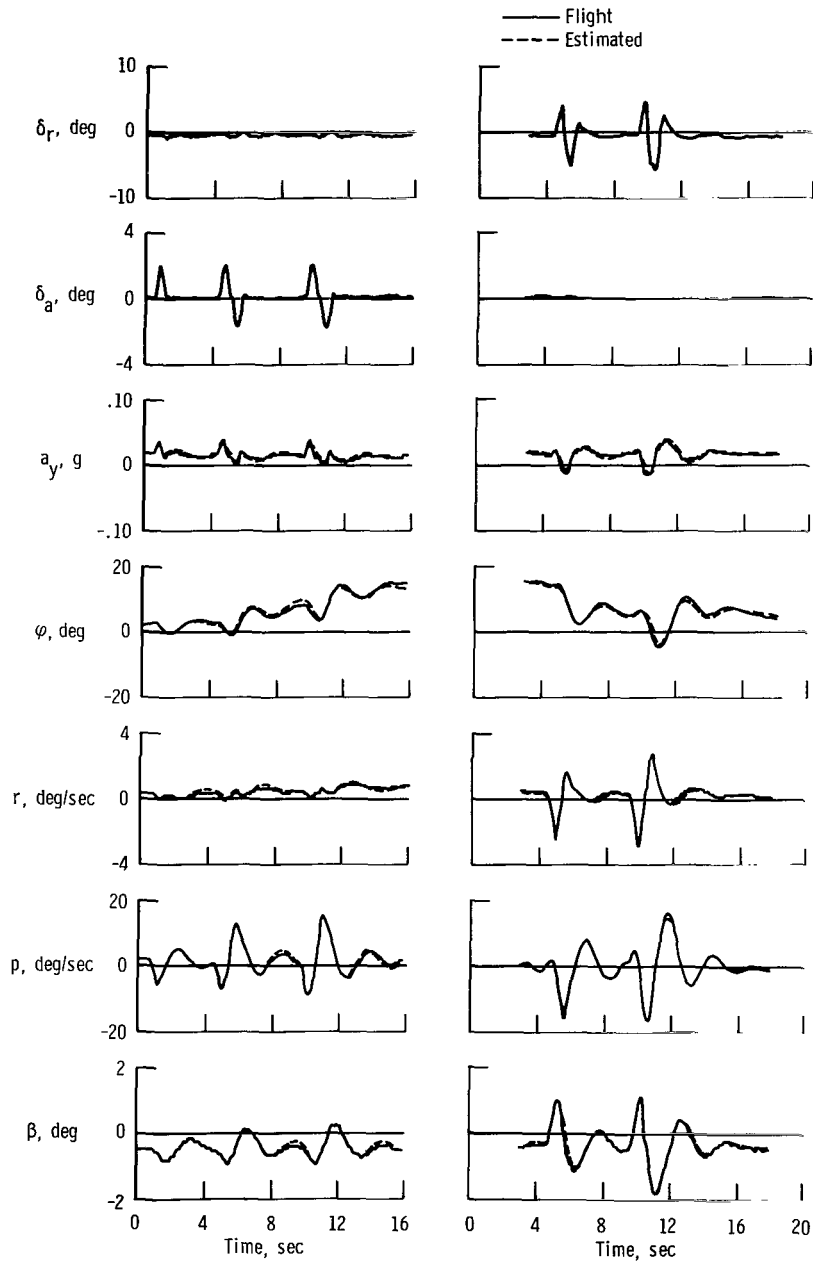

(b) Multiple maneuver analysis.

Figure 3. Concluded.

maneuver approach can also be used to enhance the data analysis by providing one set of estimates for several maneuvers made at the same flight condition.

Uncertainty Levels

Measures of the uncertainty of the estimated coefficients can be determined by calculating uncertainty levels. Uncertainty levels are proportional to the approximation of the Cramèr-Rao bounds described in reference 2 and are analogous to standard deviations of the estimates.

The Cramèr-Rao bound determined from flight data should not itself be used to define the standard deviations of the estimates, however. Although the bound provides a good estimate of the standard deviation of computed data, even the small modeling errors always present in flight data significantly affect the validity of the bound. Misinterpreting the Cramèr-Rao bounds in this manner can result in indications of much higher confidence than is justified. However, the careful interpretation of the uncertainty levels, which are formed by multiplying the Cramèr-Rao bounds by a constant to offset the tendency for overconfidence, can produce useful information.

The primary function of the uncertainty levels is to select the best estimates of a given derivative. The larger the uncertainty level, the greater the uncertainty. Therefore, a comparison of the uncertainty levels associated with the values obtained for a coefficient from different maneuvers may show one estimate to be more valid than another. If a coefficient agrees with an *a priori* estimate and has a small uncertainty level, the information from the maneuver agrees with the *a priori* estimate. If the coefficient agrees with an *a priori* estimate and has a large uncertainty level, little new information was obtained from the maneuver and the *a priori* estimate is still the best estimate. If the coefficient does not agree with the *a priori* estimate and has a small uncertainty level, new information was obtained from the maneuver and the new coefficient becomes the best estimate.

Sometimes the *a priori* weighting is not sufficient to force a poorly defined coefficient to the *a priori* value, and there is a good deal of scatter in the estimates. In this instance, the uncertainty levels show the best estimates — the estimates with the smallest uncertainty levels — and permit the data to be faired accurately. In figure 4(a), for example, there is a large amount of scatter in estimates of C_{n_p} that were obtained with three flap settings. These data yield little information about C_{n_p} . If the data in figure 4(a) are supplemented by uncertainty levels, as in figure 4(b), and the data with the small uncertainty levels are faired, a consistent trend with angle of attack which is independent of flap setting appears.

As might be expected, small uncertainty levels for C_{n_p} are usually obtained from maneuvers in which all the control inputs are made with the aileron. Data acquired with aileron control alone and rudder control alone are shown separately in figure 5(a). The fairing in the plot of the aileron data is taken from figure 4(b) and is based on the uncertainty levels. As mentioned previously, the use of multiple maneuver analysis permits the simultaneous analysis of several maneuvers,

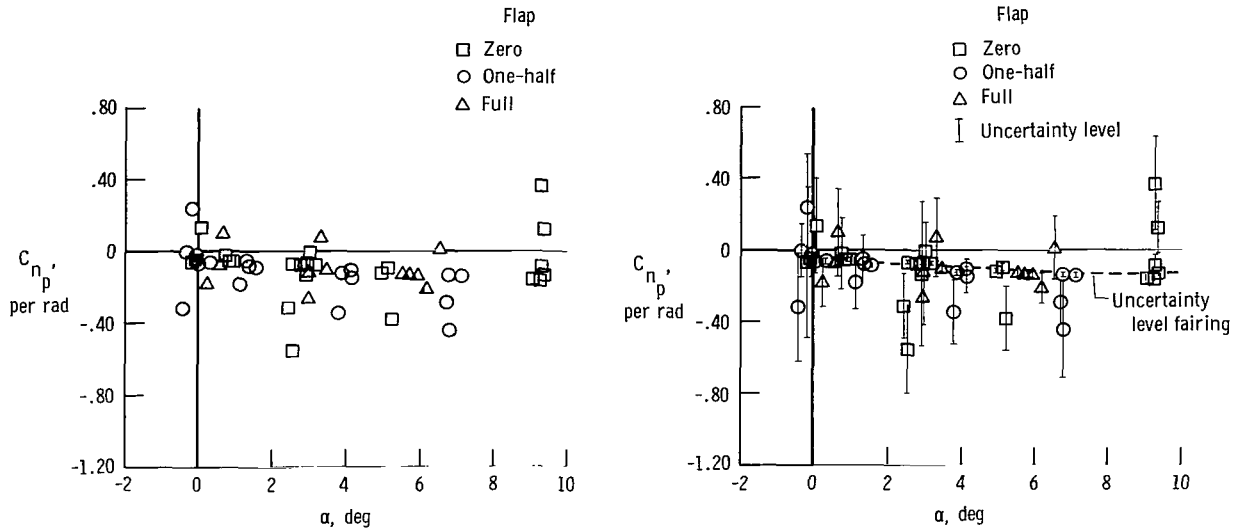

(a) Without uncertainty levels.

(b) With uncertainty levels.

Figure 4. Variation of C_{n_p} with angle of attack showing advantage of using uncertainty levels.

each of which may lack information about one or more of the derivatives. By combining them, the best overall estimate of the derivatives can be obtained. Thus, because the rudder data in figure 5(a) provide poor estimates and the aileron data provide good estimates, it seems reasonable to combine the data for the aileron and rudder inputs made at the same flight condition and to use the multiple maneuver approach. The results of this approach are shown in figure 5(b) for the data presented in figure 4(b). The fairing is that shown in figure 4(b) based on the uncertainty level analysis. The fairing agrees well with the data obtained from the multiple maneuver analysis. In this instance the uncertainty levels were not needed in the multiple maneuver analysis, because all the spurious points disappeared, but this cannot be counted on. Usually, both the uncertainty levels and the multiple maneuver analysis provide information that improves the estimates of the coefficients.

Assessing Angle of Attack

Sometimes discrepancies between derivatives estimated from a given flight and the previously available estimates are explained by uncertainties in the measured angle of attack, α_m . This uncertainty can be resolved by making an independent estimate of angle of attack. The angle of attack of the principal axis, α_0 , can be estimated by using the unknown coefficient, $\sin \alpha_0$, which occurs in the lateral-directional equations of motion. This coefficient is extremely important when no measurement of angle of attack is made. In this case an estimate of angle of attack can be obtained from $\sin \alpha_0$ so that the derivatives obtained from flight can be

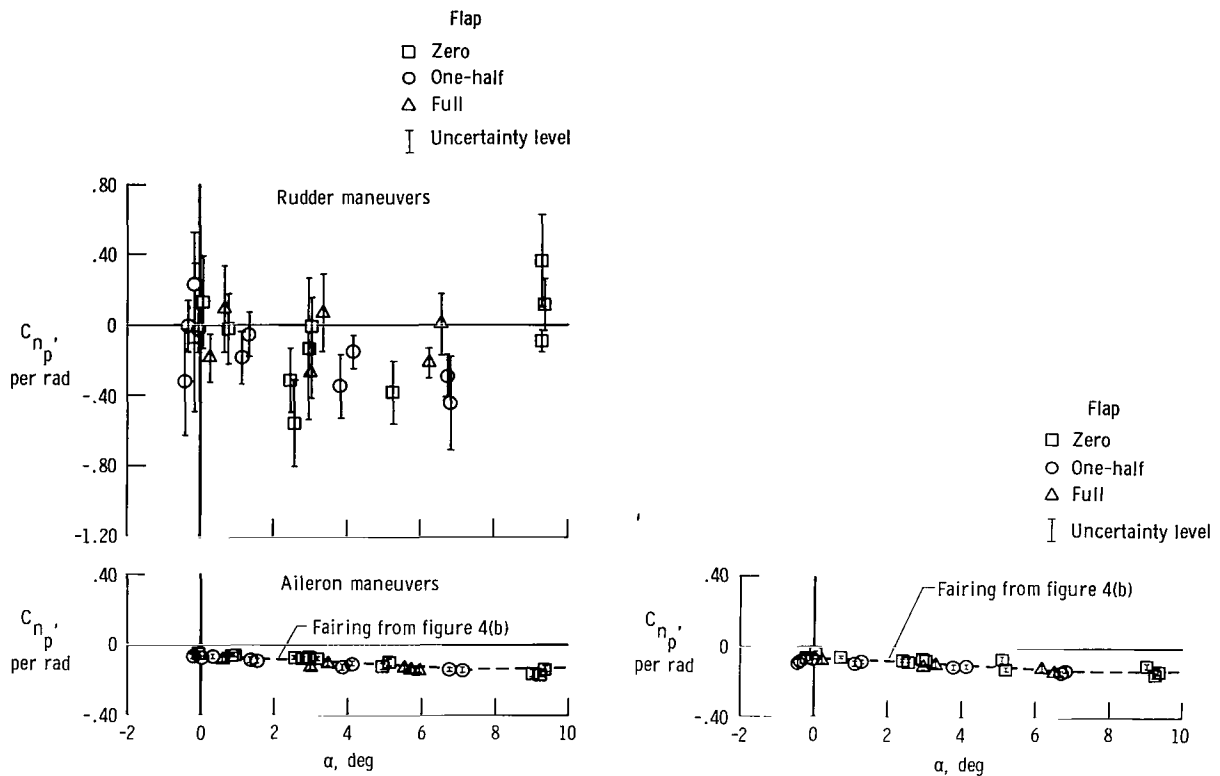

(a) Single maneuver analysis.

(b) Multiple maneuver analysis.

Figure 5. Variation of C_{n_p} with angle of attack for single and multiple maneuver analysis.

compared more meaningfully with derivatives obtained by other methods. This technique for obtaining angle of attack is particularly effective when many maneuvers are available. Figure 6 compares $\sin \alpha_0$ with α_m for a measured angle of attack range from -20° to 53° . The solid line corresponds to perfect agreement between α_0 and α_m . For the data plotted, the cross moment of inertia is approximately zero, so the principal axis is nearly coincident with the body axis; therefore, α_0 should equal α_m . As the figure shows, the bulk of the data falls near the line for α_0 equals α_m , verifying that the measured angle of attack is a fairly good indication of the actual angle of attack. As figure 6 shows, if no measurement of angle of attack had been made for this vehicle, the actual value of angle of attack could have been determined fairly accurately from $\sin \alpha_0$.

Instrumentation and Data Acquisition System

In any stability and control flight test program, difficulties with data are to be

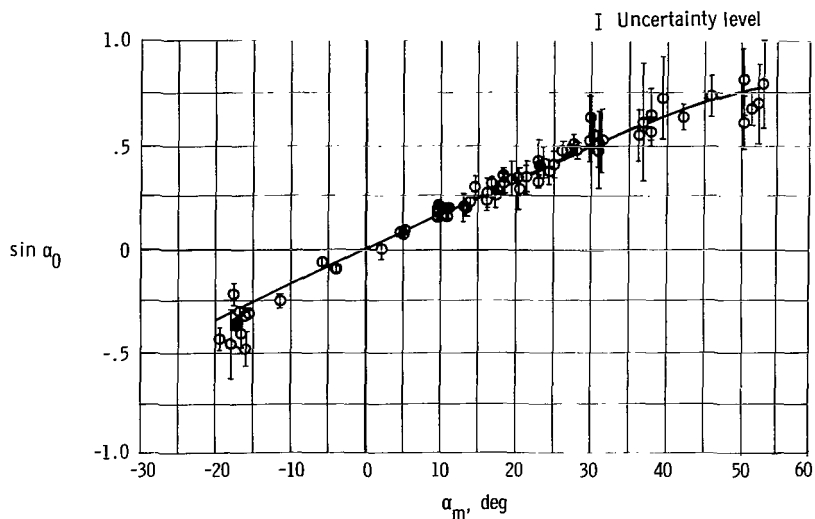
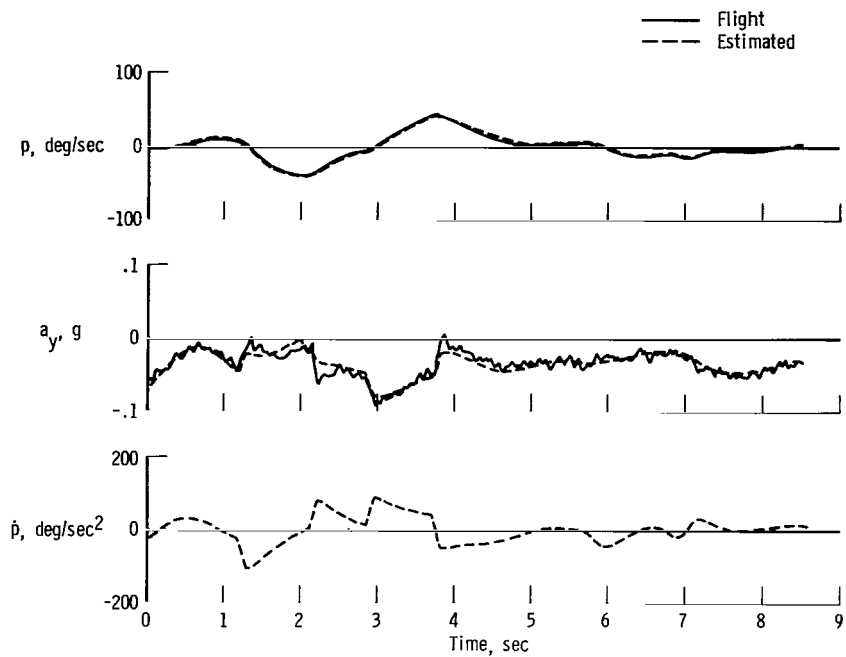

Figure 6. Comparison of angle of attack estimated from flight data and measured angle of attack.

expected. Sometimes these problems, such as data spikes, are apparent from even a cursory look at the flight test results; however, other, less obvious problems should also be expected. One of the most common sources of major error is the improper specification within the model of the instrumentation and data acquisition system.

The instruments on the aircraft must be positioned to prevent them from being affected by structural vibration or flow phenomena. Aircraft stability and control analyses must include the capability for making corrections for differences between the actual and assumed instrument locations. The accurate modeling of the angle of attack and angle of sideslip vane positions and accelerometer positions is particularly important, and corrections for these positions can be made in the MMLE program. If the data are not corrected for vane location, the fit of the data is poor, particularly when angular rates are high. If the data are not corrected for accelerometer position, some of the estimated derivatives ($C_{Y\beta}$ and $C_{Z\alpha}$, in particular) are affected. It usually becomes evident that the latter correction has not been made when the measured and computed data are compared. In figure 7(a), for example, the fit of the data for roll rate, p , is excellent, but there are some discrepancies in the fit of the data for a_y . If the figure were plotted on a less sensitive scale, the mismatch between the measured and computed values of a_y when \dot{p} is large might be overlooked. This is the type of mismatch that occurs if the accelerometer location is different from that assumed in the model. If a more precise determination of the lateral accelerometer location is made and included in the estimation process, a better fit results. The fit that resulted when the assumed location of the lateral accelerometer was changed by 15 centimeters (6 inches) is shown in figure 7(b). The fit for a_y is much better, and the fit for p is slightly improved.



(a) *Incorrect accelerometer location.*

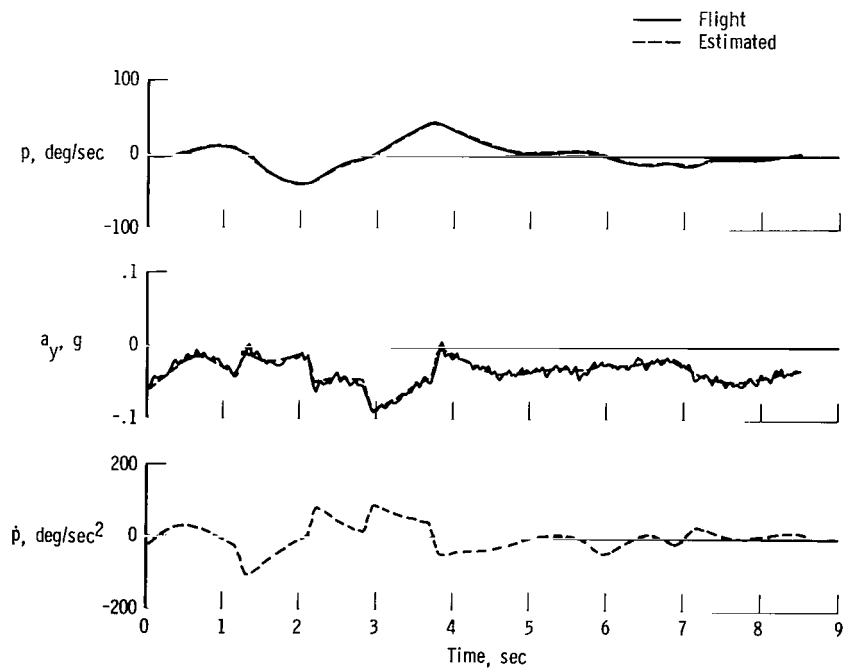

(b) *Correct accelerometer location.*

Figure 7. Effect of correct identification of lateral accelerometer location on fit of computed and flight data.

It might be thought that such a small inconsistency would have an insignificant effect on the estimates of the derivatives. Figure 8(a) shows the coefficients of $C_{Y\beta}$ estimated from the accelerometer position assumed in figure 7(a). Figure 8(b) shows the coefficients estimated when the assumed accelerometer position was changed by 15 centimeters (6 inches) as in figure 7(b). The values of $C_{Y\beta}$ in figure 8(b) are approximately 50 percent greater than in figure 8(a); obviously, the stability and control derivatives are extremely sensitive to instrument location.

The resolution and accuracy of the instrumentation must also be taken into account. If measurement noise is small, fairly low resolution can be tolerated in any noncontrol measurement, although the lower the resolution, the poorer the estimates. Low resolution in a control measurement can be intolerable, because most motions are derived from control movement. If the position of a control is not accurately defined in a sampled time history, the predicted motion will not be acceptable. If

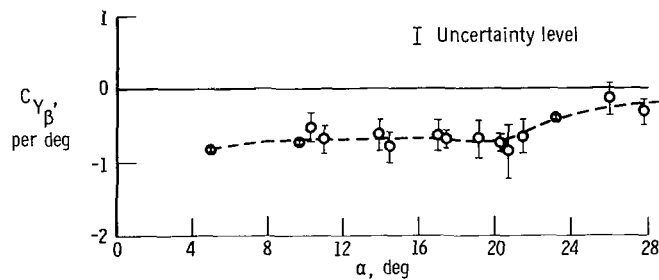

(a) Incorrect accelerometer location.

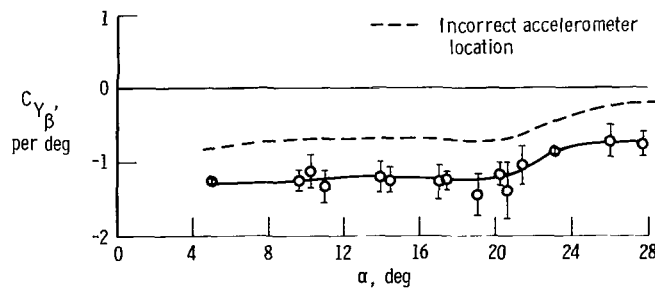

(b) Correct accelerometer location.

Figure 8. Values of $C_{Y\beta}$ found when location of lateral accelerometer is specified correctly and incorrectly.

the predicted motion is incorrect, the estimates of the derivatives, particularly the control derivatives, will be severely degraded. When the resolution of a control measurement is extremely low, the movement of the control may be missed completely.

The sampling rate chosen for the data can also affect the quality of the estimated derivatives significantly. In most aircraft stability and control analyses, the determining factor is the accurate definition of control motion. Rapid excursions are caused by rapid control inputs, and these dictate the required sampling rate. With a low sampling rate, the initiation of control motion might be missed, causing the vehicle to appear to respond before the control is moved. The resulting control time history would result in unacceptable predictions of motion, degrading the estimated derivatives. For most aircraft, a sampling rate of 20 samples per second is acceptable, but a rate of 50 samples per second is more desirable. For very slow control motions, a rate of less than 20 samples per second might prove to be acceptable.

For considerations other than control motion requirements, a sampling rate of 5 to 10 samples per cycle has been found to be acceptable. In phugoid mode analysis, for example, a sampling rate of 10 samples per cycle may result in low sampling rates. It should be noted that any integration routine used in the maximum likelihood estimation method may have to be modified if the sampling rates are low.

To economize on computer utilization, each vehicle being tested should be studied to determine the lowest sampling rate that can be tolerated. After this lowest level has been established, the effect of sampling rate should be checked periodically to make sure that the estimation process yields sufficiently good estimates.

Time and phase shifts must also be considered. Time shifts occur when digitally acquired data are sampled sequentially. Particularly when the sample interval is large, the time shift between a measurement sampled at the beginning of the interval and a measurement sampled at the end of the interval is significant. The maximum likelihood estimation algorithm assumes that all measurements are sampled simultaneously, so this time shift causes errors in the estimated coefficients. This becomes particularly important when the control input is sampled at a significantly different time than one or more of the other measurements within the sample interval. If the instrumentation system cannot otherwise meet the requirement for a minimum time between the beginning and end of the sample interval, this effect can be compensated for in the data before the analysis begins by time shifting the appropriate signals.

A phase shift due to instrumentation filters can cause a similar problem. All filter rolloff frequencies should be kept much higher than the aerodynamic frequencies of interest. If a filter is unavoidable, all the measurements should be filtered with the same filter or phase shift corrections should be applied to the raw data for all the filtered measurements.

The effects of time and phase shifts in the flight data on the stability and control derivatives are documented in reference 4. An example from reference 4 of the effect on L_β of a time shift in p , β , or δ_a is shown in figure 9. In reference 4, the yaw rate, r , and lateral acceleration, a_y , were also used in the analysis, but they were not time shifted. A positive time shift indicates that all the other

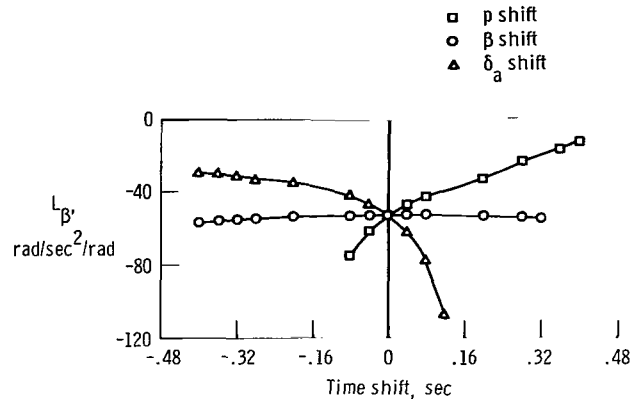

Figure 9. Estimated L_{β} as a function of time shift.

signals lead the shifted variable. As shown by the figure, shifts in p or δ_a have significant effects on the estimated value of L_{β} . The zero-shifted value is assumed to be the correct value. A positive time shift of 0.10 second for δ_a results in a 100-percent error in L_{β} . A negative time shift of 0.10 second in p results in a 50-percent error. Time shifts larger than 0.10 second have been observed in flight data. An important derivative like L_{β} can, therefore, be greatly affected by time shifts in the data. Reference 4 shows similar results for most of the stability and control derivatives of five different aircraft, although the magnitude and direction of the shift effects on the derivatives are not necessarily the same as shown in figure 9.

Modeling Problems

Modeling problems result when the assumptions made in the standard linear system model are violated. The standard model, which is defined in reference 3, assumes that all motion occurs in either the longitudinal or the lateral-directional mode. That is, the standard model is valid for level flight, steep descents, steady turns (elevated normal acceleration maneuvers), or spiral descents. Thus, when aircraft motion does not fit this description, modeling problems arise. In some instances, the linear model no longer adequately approximates aircraft motion, but a nonlinear model is known. Problems more difficult to solve arise when the aircraft is subjected to unknown external inputs or when no model is known for a phenomenon that affects the aircraft. Problems of each type are discussed below. Meaningful results can sometimes be obtained by modifying either the maximum likelihood estimation algorithm or the model itself.

Known nonlinear model. - The nonlinear problem that is easiest to solve occurs when the model, reflecting aircraft nonlinearities, is nonlinear but can be made linear with additional known inputs. Mode coupling between the lateral-directional and the longitudinal modes is an example of model nonlinearities of this type. Coupling usually occurs during stability and control maneuvers when the vehicle cannot be completely stabilized. This lack of stability occurs frequently during steady

turns or high angle of attack maneuvers. If it is assumed that the measurements of the motions in the modes not being analyzed are sufficiently accurate, these motions can be treated as known. Therefore, the coupling terms appear as known external inputs to the mode under investigation. The model is once again linear, and the maximum likelihood estimator in equations (2) or (3) can be applied and the additional terms treated as extra controls.

Figure 10(a) is a time history of a longitudinal maneuver during which lateral-directional motion was significant. The fit of the flight and estimated data is not particularly good, because the aircraft was at an extreme angle of attack and was difficult to stabilize in the lateral-directional mode. If the refinements and additions listed in the following table were made to the longitudinal equations of motion, the fit would be that shown in figure 10(b). The fit in figure 10(b) is considered exceptionally good for a high angle of attack maneuver, and the resulting derivatives are in good agreement with derivatives obtained from maneuvers performed at the same flight condition but with little lateral-directional motion.

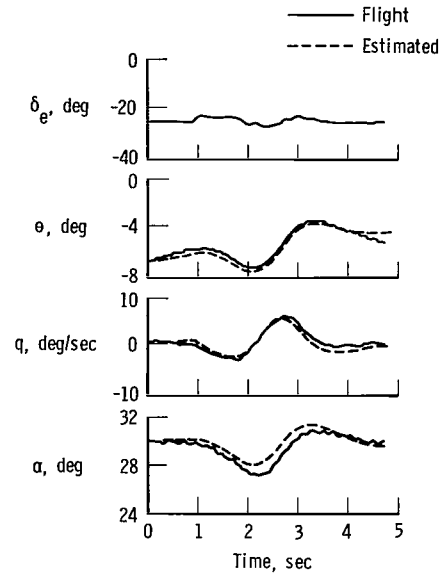

(a) Lateral-directional coupling terms ignored.

Figure 10. Effect of lateral-directional coupling terms on fit of computed and flight data for a longitudinal maneuver.

Equation defining-	Refinement or addition
$\dot{\alpha}$	$\frac{1}{\cos \beta} \left[\frac{g}{V} (\cos \theta \cos \varphi \cos \alpha + \sin \theta \sin \alpha) \right] - \tan \beta (p_b \cos \alpha + r_b \sin \alpha)$
\dot{q}	$r_b p_b \frac{I_Z - I_X}{I_Y} + (r_b^2 - p_b^2) \frac{I_{XZ}}{I_Y}$
$\dot{\theta}$	$-r_b \sin \varphi$

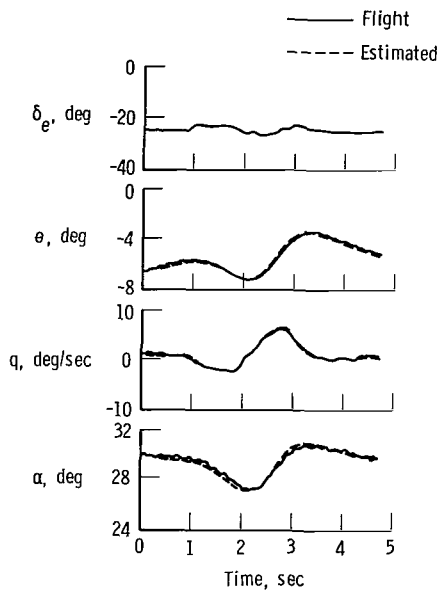

(b) Lateral-directional coupling terms included.

Figure 10. Concluded.

Sometimes the linear model of the aircraft becomes inadequate and the nonlinear model is known but cannot be put into linear form. An example of this type of problem is the need to include the drag polar in the model. The cost functional to be minimized is an extension of equation (2). The algorithm is essentially the same as that for the maximum likelihood estimator used to minimize equation (2), but the state and observation equations are no longer linear. Figure 11 is a comparison of longitudinal maneuver data and data computed on the basis of estimates from a nonlinear model for the algorithm just discussed. The fit is excellent. The drag polar obtained from this maneuver is compared in figure 12 with wind tunnel estimates of the drag polar. Agreement is reasonably good.

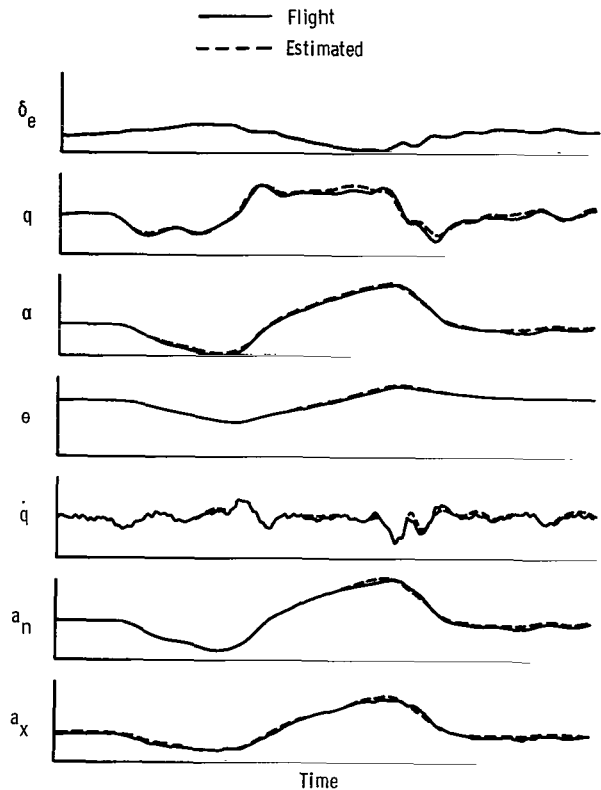

Figure 11. Comparison of flight data and data estimated by using a nonlinear model.

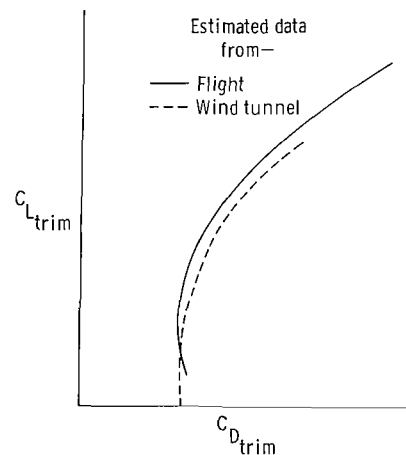
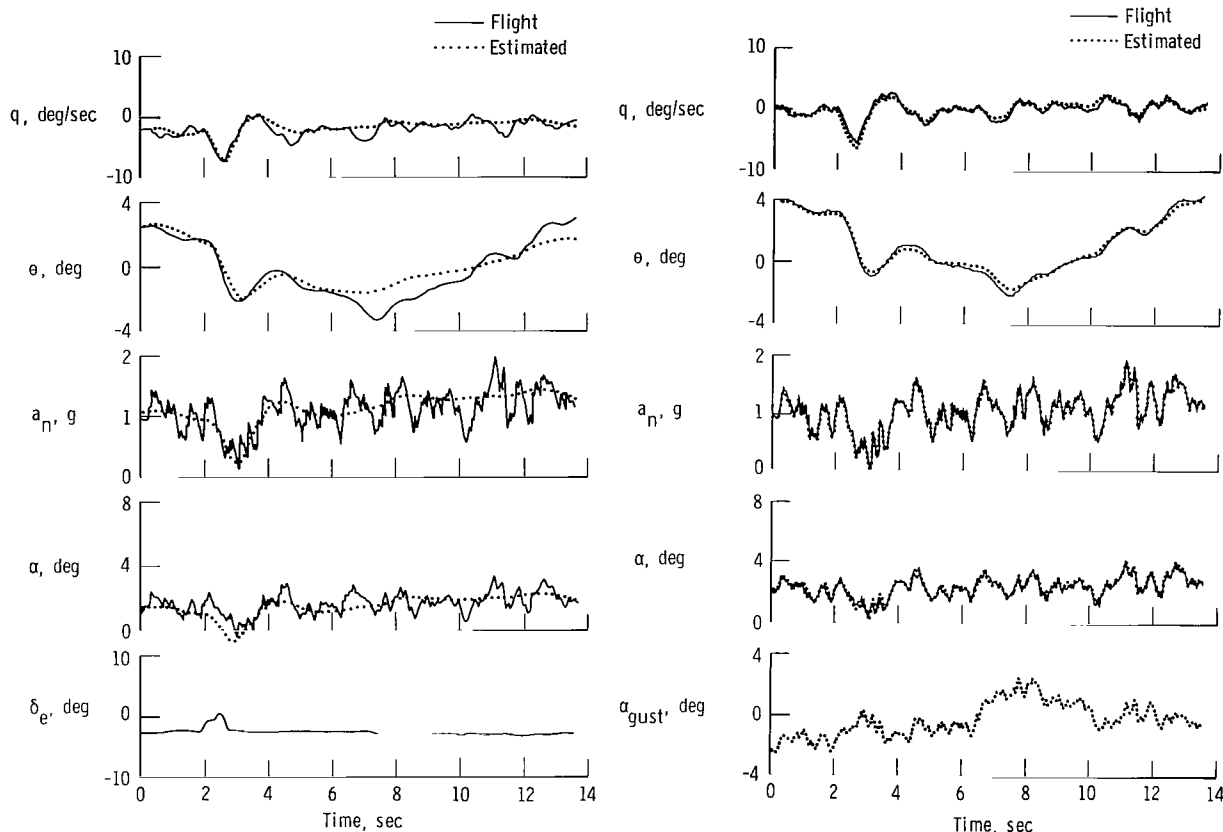

Figure 12. Comparison of drag polars obtained from estimates based on wind tunnel and flight data.

Unknown external disturbances. - Modeling problems caused by unknown external disturbances are encountered when an aircraft flies in atmospheric turbulence or in the vortex of another aircraft. Figure 13(a) is a comparison of flight data obtained in atmospheric turbulence with data obtained with the maximum likelihood estimator in equation (2). The fit is obviously unacceptable. A maximum likelihood estimator derived by Balakrishnan (ref. 5) can be applied to data obtained in atmospheric turbulence if the Dryden model of turbulence is used. The method estimates the turbulence as a function of time in addition to the unknown coefficients. The data shown in figure 13(a) were analyzed in reference 6 by using Balakrishnan's maximum likelihood estimator. As shown in figure 13(b), the fit that results is virtually perfect.



(a) Estimates that do not account for turbulence.

(b) Estimates that account for effects of turbulence.

Figure 13. Fit of computed and flight data when turbulence effects are present.

Unknown model. - The third type of modeling problem, the case in which no known model exists, usually cannot be handled. Many nonlinear models can be approximated easily by a power series expansion, but the results of this type of analysis are meaningless in that the coefficients extracted have little physical meaning. An example of a modeling problem for which even a power series expansion

does not approximate the nonlinearity occurs during flow separation. Although there are many causes of flow separation, the time at which the separation occurs and the frequency with which it occurs are random. Thus, little can be done to extract meaningful stability and control derivatives unless the separation is mild enough to permit a known model to approximate the overall resulting motion adequately. Figure 14 shows data obtained during a period when flow separation was known to exist. These data are compared with data computed from the maximum likelihood estimates obtained by using equation (2). The fit, although sometimes poor, indicates that the computed data approximate the flight data. Therefore, a fairly good linear approximation of the data was obtained with flow separation. The separation shows as a poor fit in roll rate, but the resulting estimated coefficients agreed well with those obtained when aerodynamic separation was not evident.

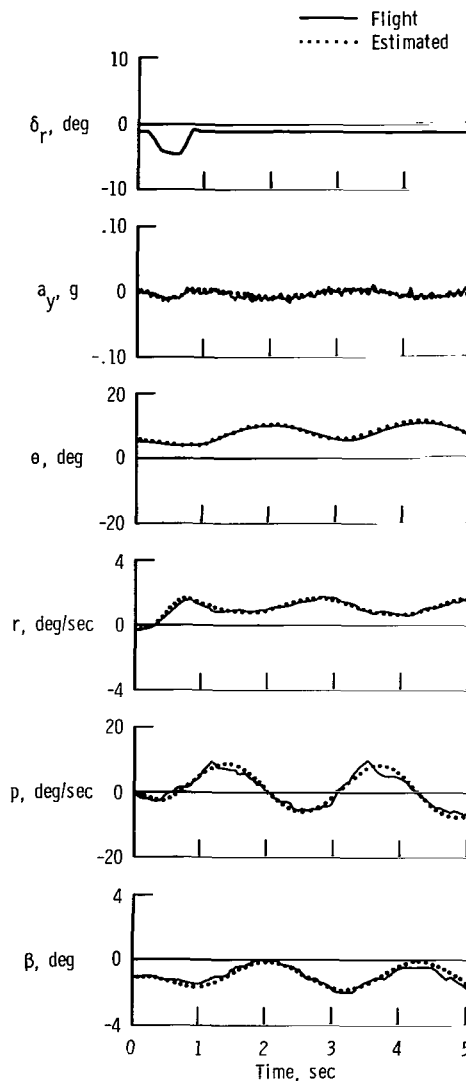

Figure 14. Comparison of flight data obtained in separated flow with data estimated without accounting for effects of separated flow.

Another time when no proven model exists is when maneuvers are performed at high angles of attack. One way to treat this problem when perturbations about the nominal are small is to assume that the system is still described by the linear equations of motion. For example, pitching coefficient, C_m , as a function of α is quite nonlinear over a large angle of attack range. If the change in angle of attack can be kept small enough for a given flight condition, the derivative C_{m_α} can be estimated and plotted as a function of angle of attack. Figure 15 shows C_{m_α} as a function of α for an angle of attack range from -20° to 50° . The estimates are in relatively good agreement with each other and show a well defined trend which is in fairly good agreement with the wind tunnel estimates. Therefore, by linearizing for small excursions from the nominal condition, a linearly approximated model can sometimes be used where there is no known nonlinear model.

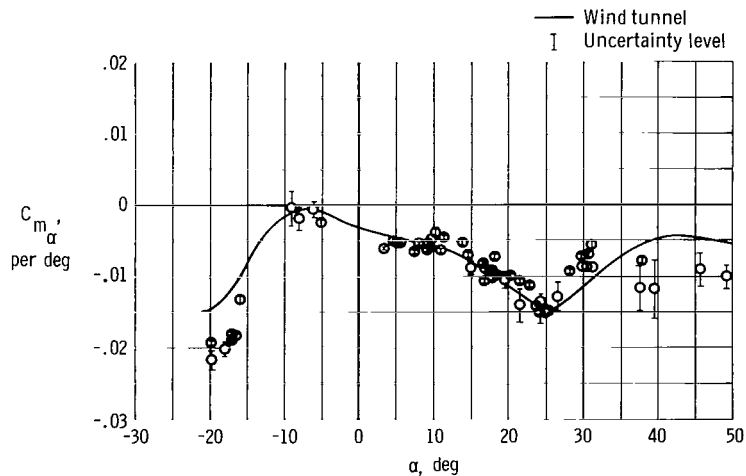

Figure 15. Comparison of flight and wind tunnel estimates of C_{m_α} over a large angle of attack range.

Overly complex models. - The three preceding sections suggest various alterations to the standard linear aircraft model for specific situations. Care must be taken, however, not to introduce unnecessary complications in the model. In some cases, such alterations significantly degrade the estimates. An example of this is an attempt to make a full six-degree-of-freedom match for a longitudinal maneuver. Since the lateral inputs are small, normally insignificant modeling errors can predominate in the analysis of lateral motion. This, in combination with the greater number of unknowns, can seriously affect the estimates of all the unknowns. If lateral motion is to be considered, the best approach is to use the measured lateral data as mentioned before. A similar procedure should be used for longitudinal motion during a lateral-directional maneuver. Many problems similar to these can arise from overly complex models. Thus, the use of the simplest model found to produce acceptable results is recommended; alterations should be made to the model only when the basic model is obviously inadequate.

DATA EDITING

Data editing problems that can be rectified fall into two categories: problems with the measurements and problems caused by inconsistencies in the model, which may be the result of something as simple as using the wrong values of some of the geometric constants. Common data and modeling problems are listed in the following table. Ways to identify the origins of the problems are indicated in the table in order of their effectiveness, based on the amount of effort required. The designations MMLE-1, MMLE-2, and MMLE-3 refer to features in the MMLE program and are subsequently described.

Problem	To identify origin of problem use-
Data spikes	Raw data, MMLE-1, MMLE-2, MMLE-3
Time dropouts	Raw data, MMLE-1, MMLE-2, MMLE-3
Data dropouts	Raw data, MMLE-1, MMLE-2, MMLE-3
Improper time increment for maneuver	Raw data, MMLE-1, MMLE-2, MMLE-3
Coupling between modes	Raw data, MMLE-3, MMLE-1
Wrong magnitudes or signs in measurements	Raw data, MMLE-3, MMLE-2, MMLE-1
Data nonlinear	MMLE-3, MMLE-2, MMLE-1, SUMMARY
Wrong sample rate	MMLE-3, MMLE-2, MMLE-1
Wrong modes being analyzed	MMLE-1, MMLE-2, MMLE-3
Low resolution in measurements	MMLE-1, MMLE-2, MMLE-3
Noise in controls	MMLE-1, MMLE-2, MMLE-3
Maneuver needs to be shortened	MMLE-1, MMLE-2, MMLE-3
Phase or time shift in signals	MMLE-3
Different frequency and damping in different signals	MMLE-3
Turbulence or wind shear during maneuver	MMLE-3
Needs to be broken into several maneuvers	MMLE-3
Low resolution in controls	MMLE-1, MMLE-2, MMLE-3, SUMMARY
Control derivatives vary but control fixed	MMLE-3, SUMMARY, MMLE-1
Velocity, dynamic pressure, or geometric constant wrong	SUMMARY, MMLE-3
Stability augmentation system on (no independent control motion)	MMLE-3, SUMMARY
Wrong center of gravity or accelerometer position	MMLE-3, SUMMARY
Poorly chosen weighting matrix	MMLE-3, SUMMARY
Wrong flight condition	SUMMARY

All the problems in the table can be isolated by looking at the raw data or by using the MMLE or SUMMARY program to find inconsistencies. Although the inspection of the raw data plots is always the easiest approach, the origin of many problems cannot be detected this way. The use of the MMLE program, although it involves more effort than inspecting the raw data, points out the origin of all the problems in the table except an incorrect specification of flight condition.

The MMLE program has several features that make this possible. First, a time history of the measured data is printed out if the weighted error (the value of the cost functional) exceeds a given error. The operation of this feature, identified as MMLE-1 in the table, usually indicates a major problem in the measured data that can be identified by studying the printout. Second, the program can be used to create plots that compare the computed data based on the startup values of the A and B matrices with the measured data (MMLE-2). Finally, the program can be used to make time history plots that compare the computed data, based on the values of the converged estimated derivatives, with the measured data (MMLE-3). These plots have high resolution for assessing modeling errors. The MMLE-3 feature can often be made more useful by increasing the *a priori* weighting when a converged solution cannot otherwise be obtained.

The SUMMARY program creates plots of all the estimated coefficients, the uncertainty levels, and any *a priori* coefficients that are available. Many types of data problems become apparent when the individual estimates, and their uncertainty levels, are compared with the rest of the estimates and uncertainty levels.

Reference 3 gives a more complete description of the options of the MMLE and SUMMARY programs that are useful in data editing.

ANALYSIS PROCEDURE

A multitude of problems can occur when flight data are analyzed, especially if the data processing is hasty and attempts to untangle problems and interpret results are left until the end. However, with careful attention to detail at the appropriate times, the analysis can proceed smoothly and quickly enough to meet the requirements of the most demanding flight test schedules.

The following outline is a guide to a desirable procedure for the analysis of flight data. The outline does not include such special situations as the concurrent use and updating of a flight simulator. The procedures followed change during the flight test program as the data system stabilizes and the expansion of the flight envelope begins.

Preflight Procedures

Before flight, the maneuvers and flight conditions are chosen, the details of the instrumentation system are specified, and the basic model is chosen. The test pilot should be informed of the requirements for each maneuver and the reasons for these requirements. Keeping the pilot informed can result in superior maneuvers, particularly if unexpected difficulties require innovations in flight. The

pilot's opinion of the feasibility of a given maneuver can also prevent wasting flight time.

In-Flight Data Inspection

During or after a flight, the raw data should be inspected for obvious data acquisition system problems. The analyst should also make a quick check for violations of basic modeling assumptions such as mode coupling, varying flight conditions, or large bank angle excursions. If such problems are recognized in time, the maneuver can be repeated during the same flight.

Data Selection and Handling

Most of the data handling required between flight and data analysis can be automated, as in the SETUP program. The maneuver times can be read by a data technician from strip charts.

Data Analysis

The MMLE program can be run by using the standard model with any alterations decided upon. All the runs should be examined for data or modeling problems. Fit errors or other abnormalities should be classified, and modeling or data problems that might cause such behavior should be considered. These problems should be verified from external sources if possible (for instance, if the flight condition seems misidentified). Cases where problems are identified or suspected should be rerun. This step should be repeated as necessary, depending on the urgency of the analysis, the economics of analyst and computer time, and the extent of the problems encountered.

Summary Plots

A plotting program like SUMMARY is used to produce derivative plots with uncertainty levels. Unexpected results should be studied to see if they could have been caused by the misidentification of the flight condition, the improper specification of instrument location, or error in the model or data. If reruns are indicated, the data analysis stage should be returned to; otherwise, the preliminary analysis is finished. Further stages might include an explanation of discrepancies or modifications to the aircraft.

The emphasis of the procedure described above is on the continual reevaluation of the modeling assumptions. When the analysis is finished, many analysts question the data acquisition system or the maximum likelihood estimation method, but they should also examine the modeling assumptions as a likely cause of difficulties.

One point remains to be mentioned. Because of the nature of parameter identification, no single maneuver, no matter how carefully analyzed, can provide a definitive description of an aircraft, or even of an aircraft at a given flight condition. This is true because all automatic tests for validity, including the uncertainty levels,

make certain assumptions about the validity of the model. Thus, there is no substitute for making several maneuvers at a single flight condition or a series of maneuvers that show a consistent trend as the flight condition changes. The purpose of the maximum likelihood estimation method is to prevent the flight time and the effort required to analyze these maneuvers from being prohibitive.

CONCLUDING REMARKS

A maximum likelihood estimation computer program has been used at the Dryden Flight Research Center for 9 years to extract stability and control derivatives from flight data. The program has been effective in analyzing 89 percent of the aircraft stability and control maneuvers attempted. More than 2200 maneuvers from 20 aircraft have been successfully analyzed. For maneuvers analyzed under ideal conditions, each successful analysis required less than 9 minutes of engineering time and approximately 1.25 minutes of CDC 6500 computer time; each maneuver required fewer than 1.2 submittals. Maneuvers that could not be analyzed successfully in a routine manner were often salvaged with more extensive analysis.

The technique used to salvage the less satisfactory maneuvers included detecting and correcting the effects of dependent or nearly dependent variables, structural vibration, data drift, inadequate instrumentation, and difficulties with the data acquisition system and the mathematical model. The use of uncertainty levels and multiple maneuver analysis also proved to be useful in improving the quality of the estimated coefficients.

*Dryden Flight Research Center
National Aeronautics and Space Administration
Edwards, California 93523
November 11, 1975*

REFERENCES

1. Taylor, Lawrence W., Jr.; and Iliff, Kenneth W.: A Modified Newton-Raphson Method for Determining Stability Derivatives From Flight Data. Computing Methods in Optimization Problems, Lotfi A. Zadeh, Lucien W. Neustadt, and A. V. Balakrishnan, eds., Academic Press, 1969, pp. 353-364.
2. Iliff, Kenneth W.; and Taylor, Lawrence W., Jr.: Determination of Stability Derivatives From Flight Data Using a Newton-Raphson Minimization Technique. NASA TN D-6579, 1972.
3. Maine, Richard E.; and Iliff, Kenneth W.: A FORTRAN Program for Determining Aircraft Stability and Control Derivatives From Flight Data. NASA TN D-7831, 1975.
4. Steers, Sandra Thornberry; and Iliff, Kenneth W.: Effects of Time-Shifted Data on Flight-Determined Stability and Control Derivatives. NASA TN D-7830, 1975.
5. Balakrishnan, A. V.: Stochastic Differential Systems I. Filtering and Control — A Function Space Approach. Lecture Notes in Economics and Mathematical Systems, 84, M. Beckmann, G. Goos, and H. P. Künzi, eds., Springer-Verlag (Berlin), 1973.
6. Iliff, K. W.: Identification and Stochastic Control With Application to Flight Control in Turbulence. UCLA-ENG-7340, School of Engineering and Applied Science, Univ. of Calif., Los Angeles, Calif., May 1973.



472 001 C1 U A 760416 S00903DS
DEPT OF THE AIR FORCE
AF WEAPONS LABORATORY
ATTN: TECHNICAL LIBRARY (SUL)
KIRTLAND AFB NM 87117

POSTMASTER: If Undeliverable (Section 158
Postal Manual) Do Not Return

"The aeronautical and space activities of the United States shall be conducted so as to contribute . . . to the expansion of human knowledge of phenomena in the atmosphere and space. The Administration shall provide for the widest practicable and appropriate dissemination of information concerning its activities and the results thereof."

—NATIONAL AERONAUTICS AND SPACE ACT OF 1958

NASA SCIENTIFIC AND TECHNICAL PUBLICATIONS

TECHNICAL REPORTS: Scientific and technical information considered important, complete, and a lasting contribution to existing knowledge.

TECHNICAL NOTES: Information less broad in scope but nevertheless of importance as a contribution to existing knowledge.

TECHNICAL MEMORANDUMS: Information receiving limited distribution because of preliminary data, security classification, or other reasons. Also includes conference proceedings with either limited or unlimited distribution.

CONTRACTOR REPORTS: Scientific and technical information generated under a NASA contract or grant and considered an important contribution to existing knowledge.

TECHNICAL TRANSLATIONS: Information published in a foreign language considered to merit NASA distribution in English.

SPECIAL PUBLICATIONS: Information derived from or of value to NASA activities. Publications include final reports of major projects, monographs, data compilations, handbooks, sourcebooks, and special bibliographies.

TECHNOLOGY UTILIZATION PUBLICATIONS: Information on technology used by NASA that may be of particular interest in commercial and other non-aerospace applications. Publications include Tech Briefs, Technology Utilization Reports and Technology Surveys.

Details on the availability of these publications may be obtained from:

**SCIENTIFIC AND TECHNICAL INFORMATION OFFICE
NATIONAL AERONAUTICS AND SPACE ADMINISTRATION
Washington, D.C. 20546**