

# NASA CR-144758

MCR 75 17 1

Volume I

Final Report

April 1975

Theory

## Computer Program System for Dynamic Simulation and Stability Analysis of Passive and Actively Controlled Spacecraft

(NASA-CR-144758) COMPUTER PROGRAM SYSTEM FOR DYNAMIC SIMULATION AND STABILITY ANALYSIS OF PASSIVE AND ACTIVELY CONTROLLED SPACECRAFT. VOLUME I. THEORY. FINAL REPORT (MARTIN MARIETTA CORP.) 115 P. HC \$5.50

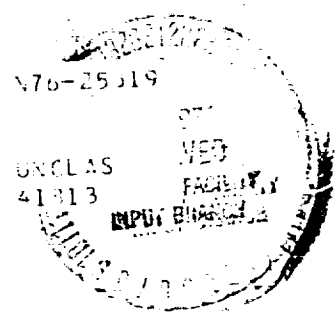

Prepared for:  
Goddard Space Flight Center  
Greenbelt, Maryland 20770



608796  
111p.

MCR-75-17  
Contract NAS5-11996

Volume I

Final  
Report

April 1975

THEORY

COMPUTER PROGRAM SYSTEM  
FOR DYNAMIC SIMULATION AND  
STABILITY ANALYSIS OF PASSIVE  
AND ACTIVELY CONTROLLED  
SPACECRAFT

Authors

Carl S. Bodley  
A. Darrell Devers  
A. Colton Park

Approved



George Morosow  
Program Manager

MARTIN MARIETTA CORPORATION  
P. O. Box 179  
Denver, Colorado 80201

## FOREWORD

---

This report, prepared by the Dynamics and Loads Section, Martin Marietta Corporation, Denver Division, under Contract NAS5-11996, presents the results of a study whose purpose was to develop a computer program system for dynamic simulation and stability analysis of passive and actively controlled spacecraft. The study was performed from May 1973 to April 1975 and was administered by the National Aeronautics and Space Administration, Goddard Space Flight Center, Greenbelt, Maryland, under the direction of Mr. Joseph P. Young.

The report is published in four volumes:

- Volume I - Theory
- Volume II - Program Users' Guide
- Volume III - Demonstration Problems
- Volume IV - Program Listing

CONTENTS

	<u>page</u>
I. INTRODUCTION . . . . .	I-1
A. Overview . . . . .	I-1
B. Description of the Physical System . . . . .	I-2 thru I-6
II. EQUATIONS OF STATE - TIME DOMAIN SIMULATION . . . . .	II-1
A. Introductory Discussion . . . . .	II-1
B. Derivation of Equations of Dynamic Equilibrium . . . . .	II-7
C. Kinematics and System Topology . . . . .	II-24
D. Development of the $\{G\}$ Force Vector . . . . .	II-35
E. Momentum Wheel Coupling . . . . .	II-40
F. Gravity Gradient Effects . . . . .	II-45
G. Provision for Inclusion of Thermal Environments . . . . .	II-48 and II-49
III. SYNTHESIS AND ANALYSIS OF THE LINEARIZED SYSTEM . . . . .	III-1
A. Introductory Discussion . . . . .	III-2
B. The Linearization Process . . . . .	III-3
C. Exchange of Variables . . . . .	III-7
D. System Transfer Functions . . . . .	III-13
E. Linear Time Domain Response . . . . .	III-30 and III-31
APPENDIX	
DEVELOPMENT OF THE INERTIAL INTEGRALS . . . . .	A-1 thru A-5
DEVELOPMENT OF ROTATION TRANSFORMATIONS . . . . .	B-1 thru B-4
TIME DERIVATIVES OF KINEMATIC COEFFICIENTS . . . . .	C-1 thru C-3
MONITOR OF SYSTEM MOMENTA AND ENERGY . . . . .	D-1 thru D-3
ROOT LOCUS SOLUTION TECHNIQUES . . . . .	E-1 thru E-5
SIMULATION NOMENCLATURE . . . . .	F-1

Figure

---

I-1	Labeling Scheme for Example System . . . . .	I-4
I-2	Typical Contiguous Bodies of the System . . . . .	I-4
II-1	The rth Flexible Body . . . . .	II-14
II-2	Two Typical Contiguous Bodies of the System . . . . .	II-29
II-3	Topology of a Typical System . . . . .	II-32
II-4	Typical Body - Momentum Wheel Relationship . . . . .	II-40
II-5	Geometry for Gravity Effects on a Typical Body . . . . .	II-45
III-1	The Quadratic Formula . . . . .	III-4
III-2	Plant/Controller Block Diagram . . . . .	III-14
III-3	Conventional Feedback System . . . . .	III-29

## ABSTRACT

---

A theoretical development and associated digital computer program system for the dynamic simulation and stability analysis of passive and actively controlled spacecraft is presented. The dynamic system (spacecraft) is modeled as an assembly of rigid and/or flexible bodies not necessarily in a topological tree configuration. The computer program system may be used to investigate total system dynamic characteristics including interaction effects between rigid and/or flexible bodies, control systems, and a wide range of environmental loadings. Additionally, the program system may be used for design of attitude control systems and for evaluation of total dynamic system performance including time domain response and frequency domain stability analyses.

Volume I presents the theoretical developments including a description of the physical system, the equations of dynamic equilibrium, discussion of kinematics and system topology, a complete treatment of momentum wheel coupling, and a discussion of gravity gradient and environmental effects.

The development of synthesis and analysis techniques for the linearized system includes a discussion of the numerical linearization technique, procedures for definition of system transfer functions, and linear time domain response.

Volume II is a program users' guide and includes a description of the overall digital program code, individual subroutines and a description of required program input and generated program output.

Volume III presents the results of selected demonstration problems that illustrate all program system capabilities.

Volume IV contains a listing of the digital code.

Applications of such methods and program systems are numerous and include simulation of the Space Shuttle payload deployment/retrieval mechanism, solar panel array deployment, antenna deployment, analysis of multispin satellites, and analysis of large, highly flexible satellites.

Our approach provides a general-purpose modeling capability for dynamic simulation and stability analysis of passive and actively controlled spacecraft. In particular, the following items are considered: (1) time domain solution of the nonlinear differential equations of motion that describe total or nominal response\* of the complete spacecraft system idealized as a collection of interconnected flexible (or rigid) bodies, (2) linearization of the governing equations by numerical means, (3) time domain solution of the linearized equations that describe the perturbation response of the complete spacecraft system about some predetermined (calculated or user-specified) nominal motion, (4) general frequency domain stability analysis corresponding to the linearized spacecraft representation, and (5) provision for arbitrary (explicitly time-dependent) loadings and environment interaction such as gravity gradient and thermally induced deformations resulting from solar radiation.

## B. DESCRIPTION OF THE PHYSICAL SYSTEM

The physical system undergoing analysis may be generally described as a cluster of contiguous, flexible structures (bodies) that comprise a mechanical system such as a spacecraft. The entire system (spacecraft) or portions thereof may be spinning or non-spinning. Member bodies of the spacecraft are capable of undergoing large relative excursions such as those of appendage deployment, or rotor/stator motions. The general system of bodies is, by its inherent nature, a feedback system wherein inertial forces (such as those due to centrifugal and Coriolis acceleration) and the restoring and damping forces are motion dependent. Also, the system may possess a control system, wherein certain position and rate errors are actively controlled through use of reaction control jets, servomotors, or momentum wheels.

---

\* The total response of the dynamic system may be, in certain cases, considered to be equilibrium state motion (nominal response) plus perturbation motion with respect to the equilibrium state.

Bodies of the system may be interconnected by linear or nonlinear springs and dampers; they may be interconnected via a mechanism that is a combination of gimbal and slider block, or any combination of the above. Also, any two bodies of the system may be free (one from the other) and possess six degrees of relative motion freedom. Also, several or all of the six degrees of relative motion freedom, between two bodies, may be a prescribed function of time (including zero motion).

For purposes of further introduction of the physical system, let us consider an illustrative example, such as the system of bodies of Figure I-1, and let this example be the prototype for all subsequent discussion and development.

In Figure I-1, we have deliberately indicated a nontopological tree configuration. There are five hinges and four bodies, thus one closed path. Consecutive integer labels are used for body reference points, for hinges, for sensor points, and for momentum wheels. The numerical order within each of the four label sets may be random; however, it is understood that body 1 (which may be any body of the system) is associated with hinge 1.

For each body of the system, there is a body-fixed, right-handed reference frame, whose origin may be at the body's mass center or at some structural hard point on the body (a body's elastic deformation is measured in its reference frame).

In this work a hinge is defined to be a pair of structural hard points (see Figure I-2) with a point situated on each of two contiguous bodies. In Figure I-2, point p and point q comprise a hinge. Clearly, a typical body may contain one or more hinge points, but a hinge may be associated with only two bodies. Hinge 1 is given special consideration. It is also a pair of points; but one of the pair is coincident with the reference point of body 1, and the other point of the pair is coincident with the inertial origin. Thus, motion "across the hinges" is used to represent system motion. The reference point of body 1 is located with respect to the inertial origin by an inertially referenced position vector. The attitude of the reference frame of body 1, with respect to the inertial frame, is represented by three Euler angles. Thus, there are six position/attitude coordinates associated with hinge 1.



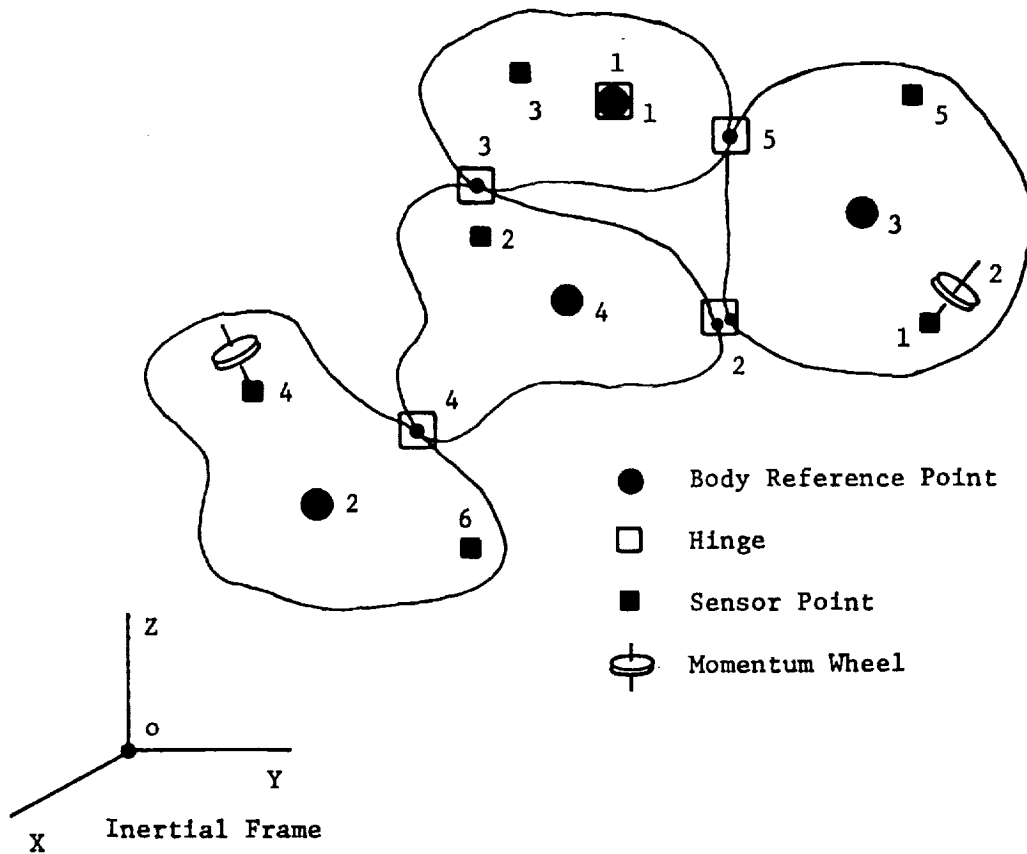

Figure I-1 Labeling Scheme for Example System

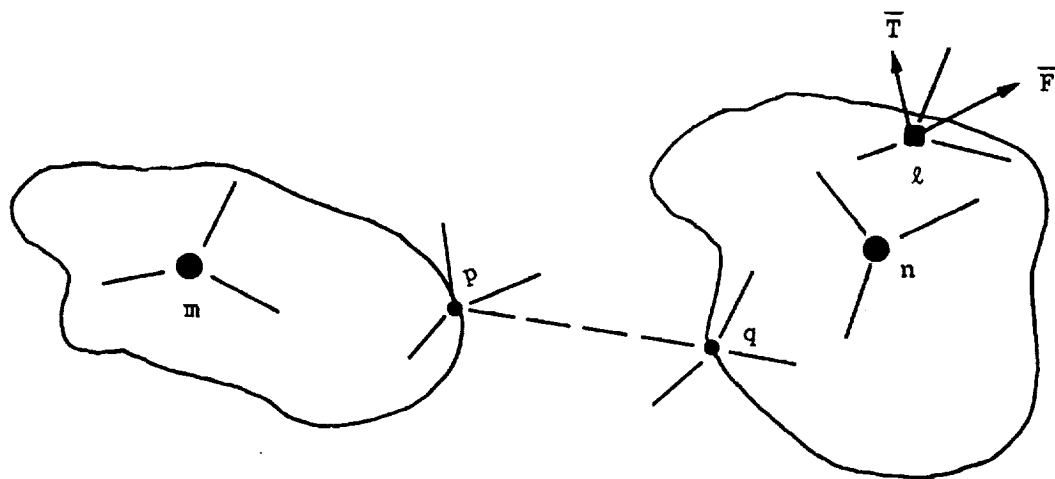

Figure I-2 Typical Contiguous Bodies of the System

Each of the remaining hinges is considered in a manner somewhat similar to that of hinge 1. Referring to Figure I-2, we note that there is an orthogonal reference frame attached to point p and another to point q. The triad of point p may have a "natural" (or undeformed) misalignment with respect to the triad of body point m plus additional misalignment due to elastic deformation. The same relationship is true concerning the points n and q.

Now there are, associated with the hinge of points p and q, six relative position/attitude coordinates. Point q is located from point p with a p-frame referenced position vector. The attitude of the q-frame with respect to the p-frame is represented by three Euler rotations. Thus, if NH is the number of system hinges, then there are  $6 \times NH$  position coordinates to be used in conjunction with modal displacement coordinates to define the system's position state. Let it be noted that only the time variable position coordinates of the  $6 \times NH$  set of candidates are considered as state vector elements (the position coordinates whose rates are constrained to zero are not included; however, the position coordinates themselves need not be zero).

The system of bodies generally has a number of so-called "sensor points." We define a sensor point to be a structural hard point, which has a right-handed orthogonal reference frame attached, that is used for a variety of purposes. A sensor point may be used to enable the program system to monitor the position, attitude, or the rates associated with a specific structural hard point. For example, a rate gyro, a star tracking device, or other motion/position sensing device is physically situated at a sensor point. Also, a sensor point is used as a point of application of a force or torque vector (see Figure I-2).

The system of bodies may contain built-in momentum wheels, some of which are constant speed wheels and others are variable speed. The variable speed momentum wheels are motor driven; the shaft torque results from a given control law. Each momentum wheel of the system must be associated with a sensor point because, for a general flexible body, the gyroscopic coupling is influenced by elastic motion.

As is indicated in Figure I-1, the system may be in a non-topological tree configuration. The methods employed in this development are such that closed loop configurations (generally referred to as nontopological) may be considered. If every body of the N-Body system is rigid, then of course there may be no closed loops, because such a system has an indeterminate "load path."

To accommodate closed loops, the system must contain sufficient structural flexibility (compliance), and therefore modal displacement coordinates, that the kinematic equations of interconnection constraint are algebraically consistent.

The program development is such that none, several, or all bodies of the N-Body system may be flexible. The system may be "forced" by such environmental factors as gravity, gravity gradient, solar pressure, thermal gradient, and aerodynamic drag.

The computer program system described herein falls into several categories of capability: (1) synthesis and time domain solution of the nonlinear differential equations of motion of the complete spacecraft system idealized as a collection of interconnected flexible (or rigid) bodies, (2) linearization of the governing equations by numerical means, (3) time domain solutions of the linearized equations that describe perturbation response of the complete spacecraft system about some predetermined (calculated or user-specified) nominal motion, and (4) general frequency domain stability analysis corresponding to the linearized spacecraft representation.

## II. EQUATIONS OF STATE - TIME DOMAIN SIMULATION

---

### A. INTRODUCTORY DISCUSSION

The state equations governing the dynamic response of a system of interconnected flexible bodies, that may be actively or passively controlled and that may be "forced" by environmental factors such as solar pressure, gravity gradient, aerodynamic drag, etc. are presented here in a concise summary form as:

$$[\text{II-1}] \quad \{\dot{U}\}_j = [m]_j^{-1} \left( \{G\}_j + [b]_j^T \{\lambda\} \right),$$

$$[\text{II-2}] \quad \{\dot{\xi}\}_j = [S_\xi]_j \{U\}_j,$$

$$[\text{II-3}] \quad \{\dot{\beta}\} = \sum_j [B]_j \{U\}_j,$$

$$[\text{II-4}] \quad \{\dot{\delta}\} = f(\{\beta\}, \{\dot{\beta}\}, \{\xi\}, \{\dot{\xi}\}, \{\delta\}),$$

subject to the constraint equations

$$[\text{II-5}] \quad \sum_j [b]_j \{U\}_j = \{\dot{\alpha}\}.$$

In Equations II-1 through II-5 the index  $j$  ranges from 1 through the number of bodies of the system. Equations II-1 through II-4 represent  $n$  first order, nonlinear, ordinary differential equations while Equation II-5 represents  $m$  additional conditions of kinematic constraint. Thus, the dimension of the state space for a given system of controlled bodies is  $(n-m)$ . That is, there are  $n-m$  state variables required to define the configuration at any instant of time  $t$ .

State variables of the configuration space include absolute velocities,  $\{U\}_j$ , modal displacements  $\{\xi\}_j$ , position coordinates (both angular and cartesian position)  $\{\beta\}$ , and additional variables  $\{\delta\}$  that we will subsequently refer to as control variables; they are variables associated with the differential equations that define a given control law. However, they may reflect any other auxiliary differential equations that are necessary to define the overall feedback system; for example, they may include thermal equilibrium states or other state variables necessary to complete definition of a state dependent environment.

The right-hand sides of Equations II-1 through II-4 are functionally dependent on all the state variables and time, although the relationships may be only termed implicit at this point. Let it suffice that, in a way of introduction, a description of the nature of the governing Equations II-1 through II-5 be given here, and that more explicit development and discussion follow in subsequent chapters.

The Equations of II-1 represent the dynamic equilibrium equations for the typical  $j$ th body of the system. They are of the form shown whether the body is treated as rigid or flexible. They state, in effect, that a deformation dependent mass matrix  $[m]_j$ , postmultiplied by a vector of relative accelerations  $\{\ddot{U}\}_j$ , produces a vector of inertial forces that is balanced by all other state and time dependent forces  $\{G\}_j$  and interconnection constraint forces,  $[b]_j^T \{\lambda\}$ . The vector  $\{G\}_j$  includes inertial forces due to centrifugal and Coriolis acceleration, as well as elastic restoring forces, damping forces, control actuator forces, and so forth. The constraint forces  $[b]_j^T \{\lambda\}$  are necessary in order that the kinematic constraint equations (II-5) are satisfied; elements of the vector  $\{\lambda\}$  are actually Lagrange multipliers, evaluated and used in the solution process.

The Equations of II-2 simply represent a selection transformation, because the vector of modal velocities  $\{\dot{\xi}\}_j$  is a subvector of  $\{U\}_j$ . The Equations of II-3, used to develop  $\{\dot{\beta}\}$ , represent a kinematical transformation, transforming nonholonomic velocities to time derivatives of position coordinates. Finally, the Equations of II-4 are auxiliary differential equations that are user defined and may be used to implement control dynamics and other feedback effects.

The constraint Equations of II-5 are kinematic conditions of a form similar to those of Equation II-3. In either case, we have a velocity transformation. We might term Equation II-5 an active set of kinematic conditions and those of Equation II-3 a passive set. The active set is used to calculate  $m$  of the dependent elements of the  $\{U\}_j$  vectors in terms of the remaining independent elements and the prescribed velocities  $\{\dot{\alpha}\}$ , some of which may be zero and some user-defined functions of time. Thus, the constraint equations are of a general form because nonholonomic, rheonomic conditions may be so represented. Given that the  $\{U\}_j$  vectors satisfy the required conditions of Equation II-5, then the position rates,  $\{\dot{\beta}\}$ , may be evaluated via the passive conditions of Equation II-3, resulting in a kinematically consistent system.

Note that there are  $m$  equations of constraint represented by II-5. There are also  $m$  Lagrange multipliers in the vector  $\{\lambda\}$ . Most often, in studies of dynamic systems, the Lagrange multipliers and the dependent velocities and accelerations are entirely eliminated from the governing equations. Such is not the case in our development. We have chosen to involve Lagrange multipliers in our equations for two reasons: (1) we wish to monitor the multipliers as a function of system motion, as they are interconnection forces and torques, and (2) for purposes of numerical implementation it is convenient to calculate and use the  $\{\lambda\}$  vector in Equation II-1. The Lagrange multipliers are calculated by differentiating Equation II-5 and combining that result with equation II-1 giving

$$[\text{II-6}] \quad \{\lambda\} = \left( \sum_j [b]_j [m]_j^{-1} [b]_j^T \right)^{-1} \left[ \{\ddot{a}\} - \sum_j \left( [\dot{b}]_j \{U\}_j + [b]_j [m]_j^{-1} \{G\}_j \right) \right].$$

Notice the following functional dependencies:

$$[\text{II-7}] \quad [b]_j = f \left( \{\beta\}_j, \{\xi\}_j \right),$$

$$[\text{II-8}] \quad [B]_j = f \left( \{\beta\}_j, \{\xi\}_j \right),$$

thus

$$[\text{II-9}] \quad \{\dot{\beta}\} = f \left( \{\beta\}, \{\xi\}, \{U\} \right),$$

$$[\text{II-10}] \quad \{\dot{\xi}\}_j = f \left( \{U\}_j \right),$$

$$[\text{II-11}] \quad \{\dot{\delta}\} = f \left( \{\beta\}, \{\dot{\beta}\}, \{\xi\}, \{\dot{\xi}\}, \{\delta\}; t \right),$$

$$[\text{II-12}] \quad \{G\}_j = f \left( \{\xi\}, \{U\}, \{\delta\}; t \right),$$

$$[\text{II-13}] \quad [m]_j = f \left( \{\xi\}_j \right),$$

$$[\text{II-14}] \quad [\dot{b}]_j = f \left( \{\beta\}, \{\dot{\beta}\}, \{\xi\}, \{\dot{\xi}\} \right),$$

thus

$$[\text{II-15}] \quad \{\lambda\} = f \left( \{\xi\}, \{\beta\}, \{U\}, \{\dot{\xi}\}, \{\dot{\beta}\}, \{\delta\}; t \right),$$

$$[\text{II-16}] \quad \text{and } \{\dot{U}\} = f \left( \{\xi\}, \{\beta\}, \{U\}, \{\dot{\xi}\}, \{\dot{\beta}\}, \{\delta\}; t \right)$$

where, in the above notation, we mean that the elements of the matrices/vectors on the left are functions of the elements of the vectors on the right. The chronology of evaluations indicated is that which must be followed in the solution process.

The differential equations of motion for the system are therefore, of the general form:

$$[II-17] \dot{y}_i = f(y_1, y_2, \dots, y_{n-m}; t),$$

and the state vector and its time derivative are arranged as follows:

$$\{y\} = \begin{bmatrix} \{U\}_1 \\ \{U\}_2 \\ \vdots \\ \{U\}_{NB} \\ \{\xi\}_1 \\ \{\xi\}_2 \\ \vdots \\ \{\xi\}_{NB} \\ \beta_1 \\ \beta_2 \\ \vdots \\ \beta_{NB} \\ \delta_1 \\ \delta_2 \\ \vdots \\ \delta_{N\delta} \end{bmatrix} \quad \{\dot{y}\} = \begin{bmatrix} \{\dot{U}\}_1 \\ \{\dot{U}\}_2 \\ \vdots \\ \{\dot{U}\}_{NB} \\ \{\dot{\xi}\}_1 \\ \{\dot{\xi}\}_2 \\ \vdots \\ \{\dot{\xi}\}_{NB} \\ \dot{\beta}_1 \\ \dot{\beta}_2 \\ \vdots \\ \dot{\beta}_{NB} \\ \dot{\delta}_1 \\ \dot{\delta}_2 \\ \vdots \\ \dot{\delta}_{N\delta} \end{bmatrix}$$

with NB the total number of bodies of the system,  $N\beta$  the total number of position coordinates necessary to orient the system and  $N\delta$  the total number of auxiliary (control) differential equations required.

Now, given that the  $\{y\}$  vector is known (numerically) from prescribed initial conditions or from numerical integration of  $\{\dot{y}\}$ , the primary task of the solution process is to numerically establish the  $\{\dot{y}\}$  vector. The  $\{\dot{y}\}$  vector is numerically (step by step) integrated so as to produce an incremented  $\{y\}$  vector, thus a sequence of time point solutions.

In way of summary, a narrative description of the steps (numerical evaluations) necessary to produce  $\{\dot{y}\}$  given  $\{y\}$ , follows.

The matrices  $[B]_j$  and  $[b]_j$  are kinematic coefficients that depend on position and modal displacement variables, and are evaluated as the first step.

Now, if available numerical techniques (also computer software and hardware) were absolutely accurate, we would be assured that the  $\{U\}_j$  vectors, resulting from numerical integration of the  $\{\dot{U}\}_j$  vectors, would satisfy the constraint equation II-5. This is not the case, therefore the second step of the solution process is to calculate the dependent elements of the  $\{U\}_j$  vectors by using Equation II-5. In fact, due to anticipating numerical inaccuracies, only the independent elements of the  $\{U\}_j$  vectors are obtained by numerical integration. There are only  $n-m$  "integrators" involved in the solution process even though all of the elements of the  $\{\dot{U}\}_j$  vectors are numerically evaluated (by use of Equation II-1); we have good numerical resolution in the independent  $\{\dot{U}\}_j$  elements due to using the Lagrange multipliers  $\{\lambda\}$ .

A kinematically consistent system results from satisfying Equation II-5. The  $\{U\}_j$  vectors may now be used with the selection and kinematic transformations as indicated by Equations II-2 and II-3 to produce (numerically) all the modal velocities  $\{\dot{\xi}\}_j$  and position coordinate rates  $\{\dot{\beta}\}$  completing the third step of the process.

Sufficient calculation has been completed to this point to then evaluate the control variable rates as per Equation II-4, producing  $\{\delta\}$ . During the process of calculating the  $\{\delta\}$  vector, all of the required control actuator torques (or forces) are calculated, because sufficient numerical information is available. All of the constituents of the torques/force vectors  $\{G\}_j$ , are now available and therefore  $\{G\}_j$ ,  $[m]_j$  and  $[b]_j$  are numerically evaluated, (refer to the functional expressions of Equations II-11 through II-14), which completes the fourth step of the process.



With reference to Equation II-6, we note that there is now sufficient numerical information to evaluate  $\{\lambda\}$ , which is then used in Equation II-1 to calculate the  $\{\dot{U}\}_j$ , completing the fifth and final step of the process.

It is noted in the above discussions that the solution process may be carried out through completion, providing the state vector is numerically known. At any step of a simulation, the  $\{y\}$  vector is known, of course, as the result of numerical integration. The initial state vector is another matter. It is difficult, if not impossible, for a user to prescribe  $\{U\}_j$  vectors that are kinematically consistent with the conditions of Equation II-5; also, the nonholonomic velocities of  $\{U\}_j$ , when considered as a complete set, are of a somewhat abstract nature. The user is in a much better posture to prescribe initial values of  $\{\dot{\beta}\}$  and  $\{\dot{\xi}\}$  (the initial velocities that are physically meaningful to him). Thus, to initiate the simulation (that is, to create an initial state vector from information the user is in a position to prescribe) some preliminary steps must be taken, as follows.

The user must prescribe initial values of the  $\{\xi\}_j$ ,  $\{\dot{\xi}\}_j$ ,  $\{\beta\}$ ,  $\{\dot{\beta}\}$  and  $\{\delta\}$  vectors; also the variable speed momentum wheel spin velocities  $\dot{\theta}$ . Now, in that  $\{\alpha\}$  (the prescribed position rates), are explicitly dependent on time and are always available, the kinematic Equations II-3 and II-5 may be used together to establish initial values of all  $\{U\}_j$ . The question inevitably arises: are the number of equations represented by II-3 and II-5 sufficient to solve for the elements of the  $\{U\}_j$ ? Let us consider the typical  $\{U\}_j$  vector. We note that there are six reference frame velocities in each  $\{U\}_j$ , namely,  $\omega_x$ ,  $\omega_y$ ,  $\omega_z$ ,  $u$ ,  $v$ , and  $w$ . There are also six relative velocities associated with each hinge. Now, if the system is a topological tree configuration, then the Equations of II-3 and II-5 comprise exactly the required number of equations to establish the reference frame velocities; that is, there are as many hinge points as there are bodies and even if every body were rigid, the system would be determinate. In this case, the initial sets of six reference frame velocities are computed via Equations II-3 and II-5; the prescribed initial  $\{\dot{\xi}\}$  vectors and momentum wheel spin velocities are simply placed in the appropriate  $\{U\}_j$  vectors, and the initial state vector is thus defined.

In the event that the system is not a topological tree configuration, then there are more equations (II-3 and II-5) to be satisfied than there are reference frame velocities (or in other words, there are more hinges than bodies). In this case, elements of the  $\{\xi\}_j$  vectors must take on the responsibility of helping to satisfy the kinematic conditions. For each hinge in excess of the number of system bodies there must be at least six deformation modes, represented by  $\xi$  coordinates, and they must be distributed throughout the system in such a way that the kinematic conditions of Equation II-5 are independent. Clearly then, when there are more hinges than bodies (nontopological tree), one or more of the bodies must be flexible for the system to be determinate. Now, when the configuration is nontopological, the user will specify initial values for all of the  $\xi$ , but he must acknowledge that they are not all independent and the dependent ones (automatically determined by the program) are calculated and replace the values that he has specified.

From these considerations, we note that the initial state vector is created by the program from information that is user supplied and that is physically meaningful to him. His only concern, regarding initial conditions, is: whether he has supplied an adequate description of system flexibility, in the event of a nontopological tree configuration, for the system's kinematical equations to be determinate.

## B. DERIVATION OF EQUATIONS OF DYNAMIC EQUILIBRIUM

The differential equations of motion and auxiliary equations that characterize a physical system may take any one of several equivalent forms. By equivalent form, we mean that the same physical system can be characterized by more than one set of mathematical variables; in any case, the number of variables must be the same. For example, the motion equations for a rigid body might be derived by using Lagrange's equations (resulting in six second-order equations), or one might use the Newton-Euler equations where translational motion is represented by three second-order equations while rotational motion is represented by six first-order equations (three moment-momentum equations and three attitude equations). In each case, there are 12 state variables.

There are a variety of alternative methods of analytical dynamics that one may select from to develop his final (programmable) equation format. A timely and valuable commentary accompanies the comprehensive comparative evaluation of these methods in a recent report by Likens\*. The basis for our development is effectively included in his discussion.

Our intent is not to highlight any particular method of analytical dynamics as being superior to the others. Clearly, the methods are all equivalent providing that they are developed through completion without any compromising simplifications. The choice of method is made after considering the requirements associated with a particular problem or computer simulation program. Our development begins with a Lagrangian approach, then through algebraic manipulation we arrive at the format of Equations II-1 through II-5.

Lagrange's equations for the general situation appear as

$$[\text{II-18}] \quad \frac{d}{dt} \left( \frac{\partial T}{\partial \dot{q}_j} \right) + \frac{\partial D}{\partial \dot{q}_j} - \frac{\partial T}{\partial q_j} + \frac{\partial V}{\partial q_j} = Q_j + \sum_{i=1}^m a_{ji} \lambda_i$$

for  $(j=1,2,\dots,n)$

$$\sum_{j=1}^n a_{ij} \dot{q}_j + a_{it} = 0$$

for  $(i=1,2,\dots,m)$

In these equations, T and V are system kinetic and potential energies, respectively, and D is the Rayleigh dissipation function (accounting for internal damping). The generalized constraint

forces  $\left( \sum_i a_{ji} \lambda_i \right)$  augment the generalized forces  $Q_j$  (that arise

due to the action of external factors) and are necessary in order that the additional conditions of constraint (the second set of Equation II-13) be satisfied. The form of the Equations II-18 is complete and general, in that they include unconservative forces (explicitly time dependent  $Q_j$  and dissipative forces  $\partial D / \partial \dot{q}_j$  and the auxiliary constraint equations (the second set of Equation II-13) are in an all encompassing form, because

---

\*Likens, P. W., "Analytical Dynamics and Nonrigid Spacecraft Simulation," Technical Report 32-1593, Jet Propulsion Laboratory, Pasadena, California, July 15, 1974.

holonomic conditions may be so represented. The coefficients ( $a_{ij}$ ,  $j=1, 2, \dots, n$ ;  $t$ ) may depend explicitly on the time ( $t$ ), thus the constraint conditions as shown account for both rheonomic and scleronomic situations.

In the equations,  $n$  is the number of generalized coordinates involved in the representation and  $m$  is the number of auxiliary conditions of constraint. Note that, although the  $q_j$  are generalized coordinates (as they must be for the Lagrangian formulation) they are independent *only* in the isolated case when  $m=0$ , or when there are no auxiliary constraint conditions. The writer has observed that some engineers share a misconception on this point, thinking that if the variables  $q_i$  are not independent then they are not generalized coordinates. In view of the  $m$  constraint equations, we simply have a set of generalized coordinates that are not independent.

In cases where all of the constraint equations are holonomic, it is theoretically possible to eliminate  $m$  of the  $q_i$  in terms of the remaining  $n-m$ . However, if any of the constraint conditions are nonholonomic, a Lagrange multiplier ( $\lambda_i$ ) must be used in conjunction with that equation. Lagrange multipliers may, of course, be used for either holonomic or nonholonomic constraints.

In that the simulation program includes mathematical representation of active or passive control for elements of the spacecraft system, there are state equations involving control variables that are additional to II-13. The manner in which the additional control equations enter into the composite system state equations is the same whether we are talking about the form given by Equation II-1 or that of Equation II-13. The control system state variables retain their identity in either case although the control forces/torques necessary to "close the loop" are transformed differently. In the case of Lagrange's equations, the control torques contribute to the generalized forces  $Q_j$  whereas in the case of the summary Equations II-1, they contribute to elements of  $\{G\}$  and may be interpreted to be ordinary forces or torques, acting at a structural hard point (or at a sensor point). Thus we will postpone further discussion of the control system until later, concentrating on the "mainline" motion equations until such a point when we can clearly indicate control system coupling.

In order to "solve" Lagrange's equations of motion, one must first define the explicit form of the kinetic and potential energy functions, the dissipation function  $D$ , and he must also define the form of the transformation relating ordinary cartesian position coordinates (positioning the typical system particle or element) to the generalized coordinates  $q_i$ ; the form of the transformation is necessary to be able to express generalized forces  $Q_j$  in terms of external ordinary forces. Having defined the form of the energy functions and coordinate transformation, one merely performs the indicated differentiations (II-13). He has not yet solved the motion equations but has only explicitly defined a system of ordinary second-order differential equations, which in many cases are nonlinear, and which require solution using numerical integration techniques.

With numerical implementation and digital programming in mind, we wish to recast the form of the ordinary differential equations. First of all, we would like for them to result in canonical first order form (the highest time derivatives appear uncoupled on the left hand side). Also, we would like to group complicated combinations of generalized velocities and displacements so that we may replace such groups with new variable names. The new variables we refer to have been called "quasi-coordinates" in the literature. This will simplify the required computer programming and minimize arithmetic computation. Also, it helps considerably in organizing the numerical algorithms necessary to evaluate the left hand side of the state equations. Thus, recasting the form of the governing equations is sufficiently justified.

We begin the recasting process by defining the forms of kinetic and potential energy, and the required transformation. First let us note that bodies of the system of flexible bodies are tentatively treated as though they were completely independent, one of the other. The influence of any one body on another is accounted for through the additional constraint conditions and the Lagrange multipliers. Thus, if we express kinetic and potential energies for the typical body and apply Lagrange's equations to it, the ordinary differential equations pertaining to it are simply a subset of Equation II-13; and we will have accounted for the total system through the representative form of the typical body.

The generalized coordinates chosen to represent the configuration of the typical body include three Euler angles to indicate attitude of the body fixed axis system relative to an inertial frame, three projections (components) of the position vector from the origin of the inertial frame to the origin of the body fixed reference system, onto the inertial axes, and N elastic displacement coordinates. We note that the origin of the body fixed axis system needn't necessarily coincide with the body's mass center. Also, the elastic displacement coordinates may be measurements of displacement at a discrete set of points on the body or they may be coordinates associated with normal vibration modes. In either case, they represent displacements measured in the body axis system. For the  $r^{th}$  flexible body, we tabulate its generalized coordinates as:

$$\{q_r\} = \left. \begin{array}{c} \phi \\ \theta \\ \psi \\ X \\ Y \\ Z \\ \xi_1 \\ \xi_2 \\ \cdot \\ \cdot \\ \xi_N \end{array} \right\}_r$$

} Attitude  
Euler Angles  
  
 } Body's Reference  
Point Position  
Coordinates  
  
 } Elastic Displace-  
ment Coordinates

Now, there exists a transformation that relates a set of nonholonomic velocities to the generalized velocities that is extensively used in recasting the equations. The transformation appears as follows:

$$\begin{array}{c}
 \omega_x \\
 \omega_y \\
 \omega_z \\
 \hline
 u \\
 v \\
 w \\
 \hline
 \dot{\xi}_1 \\
 \dot{\xi}_2 \\
 \cdot \\
 \cdot \\
 \cdot \\
 \dot{\xi}_N
 \end{array}
 =
 \begin{array}{c}
 \begin{array}{ccc|c}
 \pi_{11} & \pi_{12} & \pi_{13} & \\
 \pi_{21} & \pi_{22} & \pi_{23} & \\
 \pi_{31} & \pi_{32} & \pi_{33} & \\
 \hline
 & & & \gamma_{11} \quad \gamma_{12} \quad \gamma_{13} \\
 & & & \gamma_{21} \quad \gamma_{22} \quad \gamma_{23} \\
 & & & \gamma_{31} \quad \gamma_{32} \quad \gamma_{33} \\
 \hline
 & & & 1 \\
 & & & \quad 1 \\
 & & & \quad \cdot \\
 & & & \quad \cdot \\
 & & & \quad \cdot \\
 & & & \quad \cdot \\
 & & & 1
 \end{array}
 \end{array}
 \begin{array}{c}
 \dot{\phi} \\
 \dot{\theta} \\
 \dot{\psi} \\
 \hline
 \dot{X} \\
 \dot{Y} \\
 \dot{Z} \\
 \hline
 \dot{\xi}_1 \\
 \dot{\xi}_2 \\
 \cdot \\
 \cdot \\
 \cdot \\
 \dot{\xi}_N
 \end{array}
 \quad [II-19]$$

where in Equation II-19 the vector of nonholonomic velocities  $\{U\}$  contains the three projections  $(\omega_x, \omega_y, \omega_z)$  of the angular velocity vector  $\bar{\omega}$  onto the body fixed axes ( $\bar{\omega}$  is the angular velocity of the body reference frame), the three projections of the reference point translational velocity  $(u, v, w)$  onto the body fixed axes and the displacement rates  $\{\dot{\xi}\}$ . The elements of the transformation  $\gamma_{ij}$  ( $i, j=1, 2, 3$ ) are direction cosines; the submatrix  $[\gamma]$  is an orthonormal rotation transformation relating the attitude of the body fixed axis system to the inertial frame. The submatrix  $[\pi]$  is also a rotation transformation; however, it is not orthonormal because it relates vector components based on an orthogonal basis to those of a skew (non-orthogonal) basis; namely the axes about which Euler rotations are measured.

In short, we write

$$[II-20] \{U\} = [\beta] \{\dot{q}\}.$$

Clearly the elements of  $[\beta]$  are functions of the three Euler angles. There are 12 possible sets of Euler angles. Any one set is valid for use in subsequent development; the resulting equation form is independent of selection from the 12 sets of angles.

Elements of the transformation  $[\beta]$  may be explicitly defined in terms of three of the generalized coordinates (the Euler angles).

The kinetic energy expression for the  $r$ th body is most easily expressed (initially) in terms of the nonholonomic velocities  $\{U\}$ . Having done this,  $[\beta]$  is used to replace  $\{U\}$  with  $[\beta] \{\dot{q}\}$ . The kinetic energy is then expressed completely in terms of generalized displacements and velocities (the form necessary for applying Equation II-18).

Kinetic energy for the typical body is

$$[\text{II-21}] \quad T = \frac{1}{2} \int_V \bar{\mathbf{v}} \cdot \bar{\mathbf{v}} \sigma dV$$

where  $\bar{\mathbf{v}}$  is the velocity field,  $\sigma$  is mass density, and where integration is carried out over the volume  $V$  of the body.

The inertial position of any point  $p$  of the body is (See Figure II-1.)

$$[\text{II-22}] \quad \bar{\mathbf{r}} = \bar{\mathbf{X}}_R + \bar{\rho}_0 + \bar{\eta}$$

with  $\bar{\mathbf{X}}_R$  being the inertial position of the body's reference point ( $R$ , the origin of the body axis system),  $\bar{\rho}_0$  positions the point  $p'$  (which coincides with  $p$  in the undeformed configuration) from point  $R$ , and where  $\bar{\eta}(x, y, z, t)$  is a measure of elastic displacement.

The vectors  $\bar{\rho}_0$  and  $\bar{\eta}$  are referenced to the body axis system, thus

$$[\text{II-23}] \quad \bar{\rho}_0 = \begin{bmatrix} \bar{i} & \bar{j} & \bar{k} \end{bmatrix} \begin{bmatrix} x \\ y \\ z \end{bmatrix}$$

and

$$[\text{II-24}] \quad \bar{\eta}(x, y, z, t) = \begin{bmatrix} \bar{i} & \bar{j} & \bar{k} \end{bmatrix} \sum_{k=1}^N \left( \begin{bmatrix} \phi_{xk}(x, y, z) \\ \phi_{yk}(x, y, z) \\ \phi_{zk}(x, y, z) \end{bmatrix} \xi_k(t) \right);$$

the elastic displacement  $\bar{\eta}$  is represented as the superposition of a finite number of single valued space functions  $\bar{\phi}_k$ .



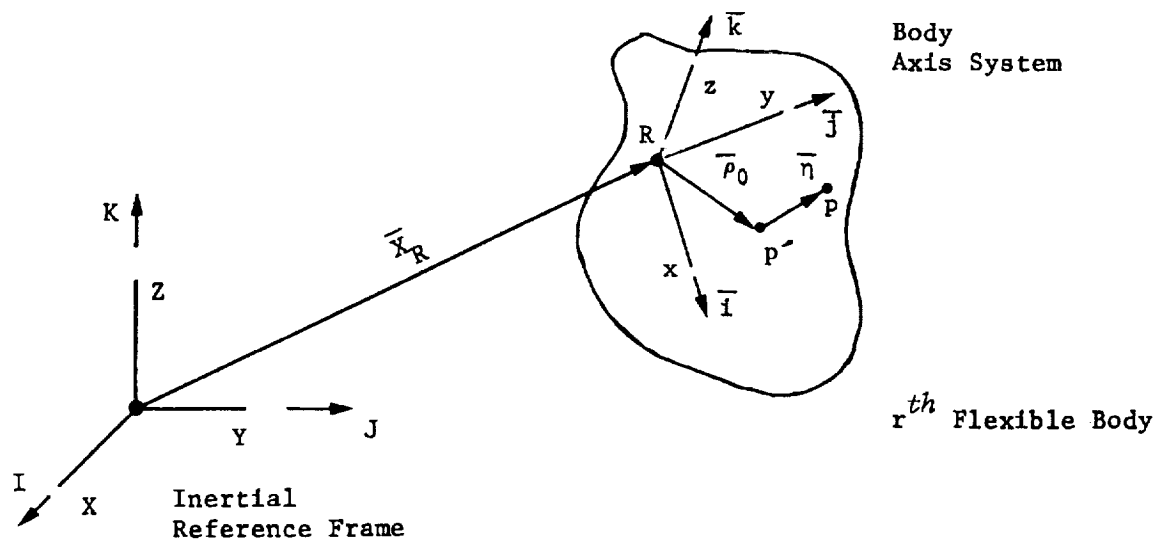

Figure II-1 The  $r^{th}$  Flexible Body

The velocity field  $\bar{v}$  is obtained as

$$[\text{II-25}] \quad \bar{v} = \frac{d\bar{r}}{dt} = \bar{v}_R + \bar{\omega} \times (\bar{p}_0 + \bar{r}) + \sum_{k=1}^N \bar{\phi}_k \dot{\xi}_k$$

$$\text{with } \bar{v}_R = \frac{d\bar{X}_R}{dt}.$$

The velocity of the reference point R may be expressed in terms of components referenced to either the inertial frame or the body frame, that is

$$[\text{II-26}] \quad \bar{v}_R = \begin{bmatrix} I & J & K \end{bmatrix} \begin{bmatrix} \dot{X} \\ \dot{Y} \\ \dot{Z} \end{bmatrix},$$

also

$$\bar{v}_R = \begin{bmatrix} \bar{I} & \bar{J} & \bar{K} \end{bmatrix} \begin{bmatrix} u \\ v \\ w \end{bmatrix}.$$

The unit vectors  $\{\bar{i}, \bar{j}, \bar{k}\}$ ,  $\{I, J, K\}$  are related through the rotation transformation  $[\gamma]$  and it follows that

$$[\text{II-27}] \quad \begin{bmatrix} u \\ v \\ w \end{bmatrix} = [\gamma] \begin{bmatrix} \dot{X} \\ \dot{Y} \\ \dot{Z} \end{bmatrix}.$$

At this point, let us introduce the repeated index summation convention to be concise. With this convention, when any two factors of a term have the same index, summation over the range of that index is implied and the  $\sum$  sign is deleted. For example, the third term on the right of Equation II-25 is

$$\bar{\phi}_k \dot{\xi}_k$$

and represents

$$\sum_{k=1}^N \bar{\phi}_k \dot{\xi}_k.$$

Now, if we substitute II-25 into II-21, the kinetic energy is

$$\begin{aligned}
\text{[II-28]} \quad T = \frac{1}{2} \int_V \left\{ \bar{v}_R \cdot \bar{v}_R + [\bar{\omega} \times (\bar{\rho}_0 + \bar{\eta})] \cdot [\bar{\omega} \times (\bar{\rho}_0 + \bar{\eta})] \right. \\
+ \bar{\phi}_k \cdot \bar{\phi}_j \dot{\xi}_k \dot{\xi}_j \\
+ 2 \bar{v}_R \cdot [\bar{\omega} \times (\bar{\rho}_0 + \bar{\eta})] + 2 \bar{v}_R \cdot \bar{\phi}_k \dot{\xi}_k \\
\left. + 2 [\bar{\omega} \times (\bar{\rho}_0 + \bar{\eta})] \cdot \bar{\phi}_k \dot{\xi}_k \right\} \text{odV}
\end{aligned}$$

or, integrating term by term over V,

$$\begin{aligned}
\text{[II-29]} \quad T = \frac{1}{2} m \begin{bmatrix} u & v & w \end{bmatrix} \begin{bmatrix} u & v & w \end{bmatrix} \\
+ \frac{1}{2} \begin{bmatrix} \omega_x & \omega_y & \omega_z \end{bmatrix} \begin{bmatrix} J_{xx} & -J_{xy} & -J_{xz} \\ -J_{yx} & J_{yy} & -J_{yz} \\ -J_{zx} & -J_{zy} & J_{zz} \end{bmatrix} \begin{bmatrix} \omega_x \\ \omega_y \\ \omega_z \end{bmatrix} \\
+ \frac{1}{2} e_{j k} \dot{\xi}_j \dot{\xi}_k \\
+ \begin{bmatrix} u & v & w \end{bmatrix} \begin{bmatrix} 0 & S_z & -S_y \\ -S_z & 0 & S_x \\ S_y & -S_x & 0 \end{bmatrix} \begin{bmatrix} \omega_x \\ \omega_y \\ \omega_z \end{bmatrix} \\
+ \begin{bmatrix} u & v & w \end{bmatrix} \begin{bmatrix} a_{xk} \\ a_{yk} \\ a_{zk} \end{bmatrix} \dot{\xi}_k \\
+ \begin{bmatrix} \omega_x & \omega_y & \omega_z \end{bmatrix} \begin{bmatrix} d_{xk} \\ d_{yk} \\ d_{zk} \end{bmatrix} \dot{\xi}_k
\end{aligned}$$

where we have used

$$\text{[II-30]} \quad m = \int_V \text{odV}$$

$$J_{xx} = \int_V [(y + \phi_{yj} \xi_j)^2 + (z + \phi_{zj} \xi_j)^2] \text{odV}$$

$$\text{[II-31]} \quad = J_{xx0} + 2(b_{yyj} + b_{zzj}) \xi_j + (c_{yjyk} + c_{zjzk}) \xi_j \xi_k$$

with

$$[\text{II-32}] \quad b_{yyj} = \int_V y \phi_{yj} \sigma dV,$$

$$b_{zzj} = \int_V z \phi_{zj} \sigma dV,$$

and

$$c_{yjzk} = \int_V \phi_{yj} \phi_{zk} \sigma dV \quad .$$

Also, we have used

$$[\text{II-33}] \quad a_{xk} = \int_V \phi_{xk} \sigma dV,$$

$$[\text{II-34}] \quad e_{jk} = \int_V \left( \phi_{xj} \phi_{xk} + \phi_{yj} \phi_{yk} + \phi_{zj} \phi_{zk} \right) \sigma dV$$

and

$$[\text{II-35}] \quad s_x = \int_V \left( x + \phi_{xj} \xi_j \right) \sigma dV$$

$$= s_{xo} + a_{xj} \xi_j,$$

$$[\text{II-36}] \quad d_{xk} = \int_V \left[ \left( y + \phi_{yj} \xi_j \right) \phi_{zk} - \left( z + \phi_{zj} \xi_j \right) \phi_{yk} \right] \sigma dV$$

$$= b_{yzk} - b_{zyk} + \left( c_{yjzk} - c_{zjyk} \right) \xi_j,$$

and also,

$$[\text{II-37}] \quad J_{xy} = \int_V \left( x + \phi_{xj} \xi_j \right) \left( y + \phi_{yj} \xi_j \right) \sigma dV$$

$$= J_{xyo} + \left( b_{xyj} + b_{yxj} \right) \xi_j + c_{xjyk} \xi_j \xi_k.$$

All other quantities involved in Equation II-29 are obtained by cyclic permutation of the indexes x, y, and z. Finally, as the kinetic energy is of quadratic form in the elements of {U}, we may express it as a triple matrix product

$$[\text{II-38}] \quad T = \frac{1}{2} [\mathbf{U}] [\mathbf{m}] \{\mathbf{U}\}$$

with

$$[\text{II-39}] \quad [\mathbf{m}] = \left[ \begin{array}{ccc|cc} J_{xx} & -J_{xy} & -J_{xz} & -S_z & S_y & d_{x1} & d_{x2} & \cdots & d_{xN} \\ & J_{yy} & -J_{yz} & S_z & -S_x & d_{y1} & d_{y2} & \cdots & d_{yN} \\ & & J_{zz} & -S_y & S_x & d_{z1} & d_{z2} & \cdots & d_{zN} \\ \hline & & & m & & a_{x1} & a_{x2} & \cdots & a_{xN} \\ & & & & m & a_{y1} & a_{y2} & \cdots & a_{yN} \\ & & & & & a_{z1} & a_{z2} & \cdots & a_{zN} \\ \hline \text{(Symmetric)} & & & & & e_{11} & e_{12} & \cdots & e_{1N} \\ & & & & & & e_{22} & \cdots & e_{2N} \\ & & & & & & & \cdots & e_{NN} \end{array} \right]$$

or in short,

$$[\text{II-40}] \quad [\mathbf{m}] = \left[ \begin{array}{c|c|c} \mathbf{J} & -\mathbf{S} & \mathbf{d} \\ \hline \mathbf{S} & \mathbf{m} & \mathbf{a} \\ \hline \mathbf{d}^T & \mathbf{a}^T & \mathbf{e} \end{array} \right] .$$

Using Equations II-40, II-19, and II-38 gives

$$[\text{II-41}] \quad T = \frac{1}{2} [\dot{\mathbf{q}}] [\beta]^T [\mathbf{m}] [\beta] \{\dot{\mathbf{q}}\} .$$

Clearly, the elements of  $[\mathbf{m}]$  depend on only the  $\xi_k$ ; the elements of  $[\beta]$  depend on the Euler angles and therefore kinetic energy is a function of generalized velocities and the generalized coordinates themselves, thus, the functional notation

$$T = T \left( q_1, q_2, \cdots, q_n; \dot{q}_1, \dot{q}_2, \cdots, \dot{q}_n \right)$$

is applicable; terms such as  $\partial T / \partial q_j$  will come about and play an important role in the simulation.

To continue it is necessary to express the potential energy  $V$  and dissipation function  $D$ . Let us assume that the elastic strain energy can be written as a positive-definite quadratic form in the elastic displacement coordinates, or

$$[\text{II-42}] \quad V = \frac{1}{2} [\xi] [k] \{\xi\};$$

the symmetric matrix  $[k]$  is developed by standard finite element techniques such as those embodied in NASTRAN. In the event  $\{\xi\}$  is a set of normal modal coordinates, then  $[k]$  is diagonal with the  $j^{\text{th}}$  diagonal element appearing as

$$[\text{II-43}] \quad k_{jj} = \omega_j^2$$

with  $\omega_j$  being the  $j^{\text{th}}$  natural frequency. Of course, normalization of the eigenvectors (mode shapes) is assumed such that the generalized mass for the  $j^{\text{th}}$  vibration mode is unity.

Now, since

$$[\text{II-44}] \quad \{\xi\} = [0|0|I_N] \{q\} \\ = [S_\xi] \{q\}$$

it follows that

$$[\text{II-45}] \quad V = \frac{1}{2} [q] [S_\xi]^T [k] [S_\xi] \{q\}.$$

Similarly,  $D$  is written as

$$[\text{II-46}] \quad D = \frac{1}{2} [\dot{q}] [S_\xi]^T [C] [S_\xi] \{\dot{q}\},$$

the matrix  $[C]$  being equivalent viscous damping for the structure; it is also developed using standard finite element techniques.

Let us now refer back to Lagrange's Equations (II-18), and re-express them in matrix format

$$[\text{II-47}] \quad \frac{d}{dt} \left( [S_\xi]^T [m] [S_\xi] \{\dot{q}\} \right) = -[S_\xi]^T \left( [k] [S_\xi] \{q\} + [C] [S_\xi] \{\dot{q}\} \right) \\ + \{Q\} + \frac{1}{2} \left\{ [\dot{q}] [\beta_{,j}]^T [m] [S_\xi] \{\dot{q}\} \right\} \\ + \frac{1}{2} \left\{ [\dot{q}] [S_\xi]^T [m] [\beta_{,j}] \{\dot{q}\} \right\} + \frac{1}{2} \left\{ [\dot{q}] [S_\xi]^T [m_{,j}] [S_\xi] \{\dot{q}\} \right\} + [a]^T \{\lambda\}$$

and

$$[\text{II-48}] \quad [a]\{\dot{q}\} = -\{a_t\}.$$

What is meant by  $[\beta_{,j}]$  and  $[m_{,j}]$  is the partial derivative of every element of  $[\beta]$  and  $[m]$  with respect to the  $j^{\text{th}}$  generalized coordinate.

Let us now define the ordinary momenta

$$[\text{II-49}] \quad \{p\} = [m] [\beta] \{\dot{q}\} \\ = [m] \{U\}.$$

Also, since  $\{U\} = [\beta] \{\dot{q}\}$

$$[\text{II-50}] \quad \text{it follows that } \{\dot{q}\} = [\beta]^{-1} \{U\}.$$

Using Equations II-49, II-50, II-47, and II-48, we may write

$$[\text{II-51}] \quad \{\dot{p}\} = -[\beta]^{-1T} [S_\xi]^T \left( [k] [S_\xi] \{q\} + [C] [S_\xi] \{\dot{q}\} \right) \\ + [\beta]^{-1T} \{Q\} + [\beta]^{-1T} \left( \left\{ [\dot{q}] [\beta_{,j}]^T \{p\} \right\} - [\dot{\beta}]^T \{p\} \right) \\ + \frac{1}{2} [\beta]^{-1T} \left\{ [U] [m_{,j}] \{U\} \right\} + [\beta]^{-1T} [a]^T \{\lambda\},$$

and

$$[\text{II-52}] \quad [a] [\beta]^{-1} \{U\} = \{-a_t\}.$$

Several observations can be made on studying Equations II-51 and II-52:

First of all, recall the form of  $[\beta]$  and  $[S_\xi]$  (Equations II-19 and II-44). It is clear from these forms that

$$[\text{II-53}] \quad [\beta]^{-1T} [S_\xi]^T \equiv [S_\xi]^T$$

$$[\text{II-54}] \quad \text{and that } [S_\xi] \{q\} = \{\xi\}$$

$$[\text{II-55}] \quad \text{and } [S_\xi] \{\dot{q}\} = \{\dot{\xi}\}.$$

Also, since the elements of  $[m]$  depend only on  $\xi_k$ , the first six elements of  $\left\{ [U] [m_{,j}] \{U\} \right\}$  are null, thus

$$[\text{II-56}] \quad [\beta]^{-1T} \left\{ [U] [m_{,j}] \{U\} \right\} = \left\{ [U] [m_{,j}] \{U\} \right\}.$$

Further, we note that the matrix  $[\beta]^{-1T}$  transforms the generalized forces  $\{Q\}$  to forces "acting in the quasi-coordinates," or let us call

$$[\text{II-57}] \{G_{\text{ex}}\} = [\beta]^{-1T} \{Q\},$$

thus  $\{G_{\text{ex}}\}$  contains ordinary forces and moments due to external sources and corresponds to time derivatives of the ordinary momenta.

Because the transformation  $[\beta]$  depends only on the Euler angles, it follows that only the first six elements of the column

$$[\beta]^{-1T} \left( \left\{ [\dot{q}] [\beta_{,j}] \{p\} \right\} - [\dot{\beta}]^T \{p\} \right)$$

are non-zero, and one finds after considerable algebraic manipulation that this column may be reexpressed as

$$[\tilde{\Omega}] \{p\}$$

or

$$[\text{II-58}] [\tilde{\Omega}] \{p\} = \left[ \begin{array}{ccc|ccc} 0 & \omega_z & -\omega_y & 0 & w & -v \\ -\omega_z & 0 & \omega_x & -w & 0 & u \\ \omega_y & -\omega_x & 0 & v & -u & 0 \\ \hline & & & 0 & \omega_z & -\omega_y \\ & & & -\omega_z & 0 & \omega_x \\ & & & \omega_y & -\omega_x & 0 \\ \hline & & & & & & p(\omega_x) \\ & & & & & & p(\omega_y) \\ & & & & & & p(\omega_z) \\ & & & & & & \hline & & & & & & p(u) \\ & & & & & & p(v) \\ & & & & & & p(w) \\ & & & & & & \hline & & & & & & p(\xi_1) \\ & & & & & & \vdots \\ & & & & & & \vdots \\ & & & & & & p(\xi_N) \end{array} \right]$$

With these observations and definitions, the Equations II-51 and II-52 may be reexpressed as

$$[\text{II-59}] \{\dot{p}\} = \{G_{\text{ex}}\} - \begin{bmatrix} 0 \\ k \end{bmatrix} \{\xi\} - \begin{bmatrix} 0 \\ c \end{bmatrix} \{\dot{\xi}\} + [\tilde{\Omega}] \{p\} \\ + \frac{1}{2} \{ [U]_{[m,j]} \{U\} \} + [b]^T \{\lambda\},$$

$$[\text{II-60}] \text{ and } [b] \{U\} = \{\dot{a}\}$$



where we have used

$$[\text{II-61}] \quad [b] = [a] [\beta]^{-1}$$

and

$$[\text{II-62}] \quad \{\dot{a}\} = -\{a_t\}.$$

Notice that the constraint equations (II-60) are now expressed in terms of the nonholonomic velocities  $\{U\}$ ; the coefficients  $[b]$  are obtained directly from relatively simple, vectorial expressions of kinematic constraint. The same  $[b]$  coefficients are transposed and used to multiply  $\{\lambda\}$ , producing constraint forces/torques corresponding to the ordinary momenta.

If we now define the  $\{G\}$  vector to be

$$[\text{II-63}] \quad \{G\} = \{G_{ex}\} - \begin{bmatrix} 0 \\ k \end{bmatrix} \{\xi\} - \begin{bmatrix} 0 \\ c \end{bmatrix} \{\dot{\xi}\} + [\tilde{\Omega}] [m] \{U\} \\ + \frac{1}{2} \left\{ [U] [m_{,j}] \{U\} \right\} - [\dot{m}] \{U\}$$

it follows that we may write dynamic equilibrium equations for the typical  $r^{th}$  body as

$$[\text{II-64}] \quad \{\dot{U}\}_r = [m]_r^{-1} \left( \{G\}_r + [b]_r^T \{\lambda\} \right)$$

to be used in conjunction with system kinematic constraint equations

$$[\text{II-65}] \quad \sum_r [b]_r \{U\}_r = \{\dot{a}\}$$

which is the same form as that given by Equations II-1 and II-5.

The last three terms of  $\{G\}$  given in Equation II-63 are inertial forces that involve velocities and displacements of the body. The matrix  $[m]$  is an instantaneous inertia matrix, depending on instantaneous values of the deformation coordinates  $\{\xi\}$ . The centrifugal and Coriolis effects are completely accounted for within the framework of the assumed velocity field (given by Equation II-25). These effects would not be accounted for if we neglected "tangential" velocity due to elastic displacement; that is, if we assumed that  $|\bar{\omega} \times \bar{\eta}| \ll |\bar{\omega} \times \bar{\rho}_0|$ . In this case, the inertia would be constant, independent of  $\{\xi\}$ .

An accurate definition of the dynamic equilibrium equations clearly hinges on a complete and accurate definition of the constituents of the  $\{G\}_r$  vector, which includes the inertia matrix  $[m]_r$ . Also, the kinematic coefficients  $[b]_r$  must be developed in an exact fashion. Kinematics and a more explicit development of  $\{G\}$  are given in subsequent sections.

### C. KINEMATICS AND SYSTEM TOPOLOGY

From a Lagrangian formulation all of the generalized forces, not derivable from a potential function, ordinarily appear as  $\{Q\}$  on the right side of Lagrange's equations of motion. We have accounted for internal damping forces with the use of Rayleigh's dissipation function  $D$  and for generalized constraint forces through use of Lagrange's multipliers.

Thus, the generalized forces that remain to deal with include those due to external factors such as aerodynamic drag, solar pressure, and other commonly encountered environmental loadings.

We also intend to treat control forces (servodrive torques, reaction jets, etc.) as though they were external. They are not explicitly external, of course, because they depend on time through position and rate errors that are functions of elements of the state vector and on control system state variables that arise from a given control law.

Let us assume that there is a finite number of points on the typical body where a force vector (or torque) is known to act. Each of these force/torque vectors contributes to the generalized forces  $\{Q\}$ . The generalized forces are calculated by expressing the virtual work of the external ordinary forces in terms of virtual displacements of the points of force application. The transformation relating ordinary coordinates to generalized coordinates is then used to define the explicit form of the generalized forces.

For example, suppose that a force  $\bar{f}_p$  and torque  $\bar{T}_p$  act at point  $p$  of the typical body. Their virtual work is

$$[II-66] \delta W = \bar{f}_p \cdot \delta \bar{r}_p + \bar{T}_p \cdot \delta \bar{\theta}_p.$$

Notice that we treated the virtual rotation  $\delta \bar{\theta}_p$  as a vector quantity. This is valid, even though a general rotation is not a vector quantity, for the virtual rotation is infinitesimal and therefore is a vector. Further, because virtual displacements are infinitesimal, we may express  $\delta \bar{r}_p$  and  $\delta \bar{\theta}_p$  in terms of virtual displacements of the quasi-coordinates; that is

$$\begin{aligned}
 \text{[II-67]} \quad \delta \bar{r}_p = [\bar{i} \quad \bar{j} \quad \bar{k}] & \left( \begin{bmatrix} \delta r_1 \\ \delta r_2 \\ \delta r_3 \end{bmatrix} + \begin{bmatrix} 0, & (z_p + \eta_{zp}), & -(y_p + \eta_{yp}) \\ -(z_p + \eta_{zp}), & 0, & (x_p + \eta_{xp}) \\ (y_p + \eta_{yp}), & -(x_p + \eta_{xp}), & 0 \end{bmatrix} \begin{bmatrix} \delta \theta_x \\ \delta \theta_y \\ \delta \theta_z \end{bmatrix} \right. \\
 & \left. + \begin{bmatrix} \phi_{xj}(x_p, y_p, z_p) \\ \phi_{yj}(x_p, y_p, z_p) \\ \phi_{zj}(x_p, y_p, z_p) \end{bmatrix} \delta \xi_j \right)
 \end{aligned}$$

and

$$\text{[II-68]} \quad \delta \bar{\theta}_p = [\bar{i} \quad \bar{j} \quad \bar{k}] \left( \begin{bmatrix} \delta \theta_x \\ \delta \theta_y \\ \delta \theta_z \end{bmatrix} + \begin{bmatrix} \sigma_{xj}(x_p, y_p, z_p) \\ \sigma_{yj}(x_p, y_p, z_p) \\ \sigma_{zj}(x_p, y_p, z_p) \end{bmatrix} \delta \xi_j \right)$$

where  $(\delta r_1, \delta r_2, \delta r_3)$  are components of virtual displacement of the body's reference point R,  $(\delta \theta_x, \delta \theta_y, \delta \theta_z)$  are components of virtual rotation of the body axis system, and  $(\sigma_{xj}, \sigma_{yj}, \sigma_{zj})$  are components of the  $j^{\text{th}}$  space function  $\bar{\sigma}_j$  representing elastic rotation at point p (modal slopes, for example).

Now, let us assume that the force and torque vectors ( $\bar{f}_p$  and  $\bar{T}_p$ ) are referenced to the body axis system, thus they may be written as

$$\text{[II-69]} \quad \bar{f}_p = [\bar{i} \quad \bar{j} \quad \bar{k}] \begin{bmatrix} f_{xp} \\ f_{yp} \\ f_{zp} \end{bmatrix}$$

and

$$\text{[II-70]} \quad \bar{T}_p = [\bar{i} \quad \bar{j} \quad \bar{k}] \begin{bmatrix} T_{xp} \\ T_{yp} \\ T_{zp} \end{bmatrix} .$$

We note that virtual displacements of the quasi-coordinates are related to virtual generalized displacements by the same transformation that relates nonholonomic velocities to generalized velocities (See II-19). It follows that the virtual work due to

$\bar{f}_p$  and  $\bar{T}_p$  may be written as

$$[II-71] \delta W = [\delta q] [3]^T \begin{bmatrix} 1 & & & & -(z_p + \eta_{zp}) & y_p + \eta_{yp} \\ & 1 & & z_p + \eta_{zp} & & -(x_p + \eta_{xp}) \\ & & 1 & -(y_p + \eta_{yp}) & x_p + \eta_{xp} & \\ & & & 1 & & \\ & & & & 1 & \\ & & & & & 1 \\ \sigma_{x1})_p & \sigma_{y1})_p & \sigma_{z1})_p & \phi_{x1})_p & \phi_{y1})_p & \phi_{z1})_p \\ \vdots & \vdots & \vdots & \vdots & \vdots & \vdots \\ \sigma_{xN})_p & \sigma_{yN})_p & \sigma_{zN})_p & \phi_{xN})_p & \phi_{yN})_p & \phi_{zN})_p \end{bmatrix} \begin{bmatrix} T_{xp} \\ T_{yp} \\ T_{zp} \\ f_{xp} \\ f_{yp} \\ f_{zp} \end{bmatrix} \quad (6+N \times 6)$$

The virtual work is also expressed

$$\delta W = [\delta q] \{Q\},$$

and because  $\delta q_j$  is arbitrary and independent (it is treated as though independent in the face of Lagrange multipliers and constraint equations) it follows that

$$[II-72] \{Q\} = [\beta]^T [b_p]^T \begin{Bmatrix} T_p \\ f_p \end{Bmatrix}.$$

The Equations II-71 or II-72 have a noteworthy geometrical interpretation. Notice that the first three lines of  $[b_p]^T \begin{Bmatrix} T_p \\ f_p \end{Bmatrix}$  are components of the resultant torque vector  $\bar{T}_p + (\bar{\rho}_0 + \bar{\eta}) \times \bar{f}_p$ , acting at the body's reference point R. The second three lines are

components of the resultant force vector  $\bar{f}_p$ , while the  $j^{th}$  line ( $j > 6$ ) corresponds to the standard procedure (of structural dynamicists) to calculate  $Q_{\epsilon j}$ , or as it is usually expressed, generalized forces acting in deformation modes are

$$\{Q\} = [\phi]^T \{f\}.$$

Also, recalling the form of  $[\beta]$ , (Equation II-19), we note that  $[\pi]^T$  resolves the resultant torque vector (about orthogonal body axes) to components about skew axes about which Euler rotations are measured while  $[\gamma]^T$  resolves the resultant force vector (about orthogonal body axes) to components along the inertial axes. Further, we notice that  $[b_p]$  is a matrix of coefficients that relates the velocity of any point  $p$  to the vector  $\{U\}$ . This gives us some additional insight as to why the same coefficients that are used in the kinematic constraint equations (II-60) are used (in transposed form) to multiply  $\{\lambda\}$  producing resultant constraint forces.

Thus, we have pointed out the remarkable duality of purpose associated with  $[b]$  type coefficients. They are initially expressed by writing simple kinematic velocity relationships. The coefficients  $[b]^T$  are then used to transform discrete ordinary forces and torques to equivalent forces and torques acting through the body's reference point  $R$ . The matrix  $[\beta]$ , which is also a velocity transformation, is transposed to produce the transformation to generalized forces (should they be desired).

For our ordinary momenta equations we simply wish to express  $\{G_{ex}\}$  which (following Equation II-57) is given by

$$\begin{aligned} \text{[II-73]} \quad \{G_{ex}\}_p &= [\beta]^{-1T} \{Q\} \\ &= [\beta]^{-1T} [\beta]^T [b_p]^T \begin{Bmatrix} T_p \\ f_p \end{Bmatrix} \\ &= [b_p]^T \begin{Bmatrix} T_p \\ f_p \end{Bmatrix}. \end{aligned}$$

This  $\{G_{ex}\}_p$  given by II-73 reflects only the contribution of the force/torque acting at a single point  $p$ . The total  $\{G_{ex}\}$  must be obtained by summing over all the points of the body where forces and torques act, or

$$\text{[II-74]} \quad \{G_{ex}\} = \sum_{i=1}^{NP} [b_{p_i}]^T \begin{Bmatrix} T_{p_i} \\ f_{p_i} \end{Bmatrix}.$$

Kinematic coefficients  $[b_p]$  such as those of the previous example, will be required throughout in our formulation of the state equations. They are used to synthesize the constraint equations, to produce  $\{G\}$ , and they are even involved in the velocity transformation of II-3. It is therefore advantageous for us to think of a "bank" or collection of all the required kinematic coefficients to be put together in a semiautomatic fashion by using input specifications to the digital program.

1. Sensor Point Kinematics - Force/Torque Transformations

Consider the typical structural hard point  $s$  (See Figure II-2). Let us assume a right-handed triad is fixed to point  $s$  and that the elements of the triad are unit vectors labeled  $\bar{l}$ ,  $\bar{m}$ , and  $\bar{n}$ . Now body  $n$  (which has point  $s$  on it) also has a right-handed triad fixed to point  $n$ . Suppose that, even when body  $n$  is in an undeformed state, the  $s$ -triad is misaligned with respect to the  $n$ -triad. When the body deforms there may be further angular misalignment between the two triads. Thus, the relationship linking the two sets of unit vectors is

$$[\text{II-75}] \begin{bmatrix} \bar{l} \\ \bar{m} \\ \bar{n} \end{bmatrix} = \begin{bmatrix} R_{s-s'} \\ \end{bmatrix} \begin{bmatrix} R_{s'-n} \\ \end{bmatrix} \begin{bmatrix} \bar{i} \\ \bar{j} \\ \bar{k} \end{bmatrix}$$

with  $[R_{s-s'}]$  and  $[R_{s'-n}]$  being orthonormal rotation transformations, the first relating the "naturally" misaligned triads via constant Euler rotations and the second accounting for additional rotation due to the body's deformation at point  $s$ .

The structural deformation at point  $s$  is assumed to be sufficiently small that the Euler rotations associated with  $[R_{s'-n}]$  may be evaluated through use of

$$[\text{II-76}] \begin{bmatrix} \theta_1 \\ \theta_2 \\ \theta_3 \end{bmatrix} = [\sigma_s] \{\xi\},$$

where  $[\sigma_s]$  is a  $(3 \times N)$  matrix of modal rotation amplitudes (each of the  $N$  columns corresponds to a deformation mode) at point  $s$ . Let us consisely denote the triads associated with points  $n$  and  $s$  by  $\{\bar{e}_n\}$  and  $\{\bar{e}_s\}$  respectively. Then we may express the relationship linking the two sets of unit vectors as

$$[\text{II-77}] \{\bar{e}_s\} = \begin{bmatrix} R_{s-n} \\ \end{bmatrix} \{\bar{e}_n\}.$$

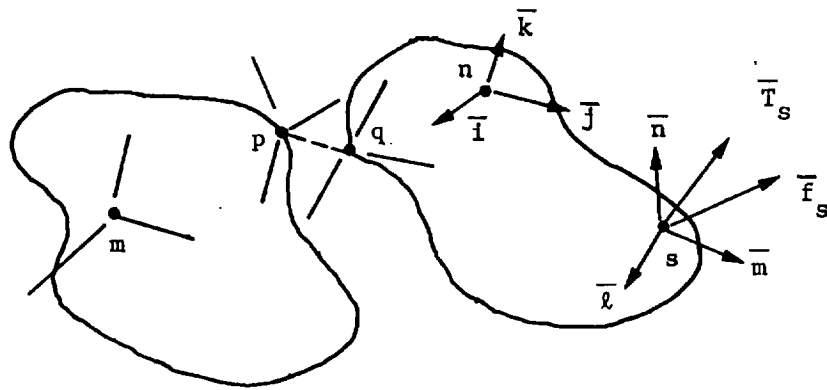

Figure II-2 Two Typical Contiguous Bodies of the System



There is a requirement for expressing the absolute velocity of a typical s-point and the angular velocity of the typical s-triad, in subsequent kinematic development, in terms of velocity states of a given body. Let us think of a six long vector (column) of velocity components (three rotational and three translational) that are projections of  $\bar{\omega}_s$  and  $\bar{v}_s$  onto the s-triad axes. It is related to the  $\{U\}_n$  vector for the body by the transformation

$$\text{[II-78]} \quad \begin{bmatrix} \omega_{xs} \\ \omega_{ys} \\ \omega_{zs} \\ u_s \\ v_s \\ w_s \end{bmatrix}^{(s)} = \begin{bmatrix} \left[ \begin{array}{c|c} [sR_n] & [0] \\ \hline [sR_n] & [\sigma_s] \end{array} \right] \\ \left[ \begin{array}{c|c} [sR_n] & [S_{ns}^{(n)}] \\ \hline [sR_n] & [h_s] \end{array} \right] \end{bmatrix} \begin{bmatrix} \omega_x \\ \omega_y \\ \omega_z \\ u \\ v \\ w \\ \cdot \\ \xi_1 \\ \cdot \\ \xi_2 \\ \cdot \\ \cdot \\ \cdot \\ \cdot \\ \xi_N \end{bmatrix}^{(n)}$$

with  $[h_s]$  and  $[\sigma_s]$  representing matrices of displacement and rotation amplitudes, respectively, and with  $[S_{ns}^{(n)}]$  being an anti-symmetric matrix accounting for a vector cross product, or

$$\text{[II-79]} \quad \left[ S_{ns}^{(n)} \right] = \begin{bmatrix} 0 & z_s + \eta_{zs} & -(y_s + \eta_{ys}) \\ -(z_s + \eta_{zs}) & 0 & x_s + \eta_{xs} \\ y_s + \eta_{ys} & -(x_s + \eta_{xs}) & 0 \end{bmatrix}$$

The superscripts used in Equations II-73 and II-79 are used to indicate the frame to which the velocity components are referenced.

Kinematic coefficients such as those of Equation II-78 are generated for each so-called sensor point of the system of bodies. They are used by the simulation program to produce contributions to  $\{G_{ex}\}$  from given force/torque components in the manner indicated by Equation II-74.

## 2. Hinge Point Kinematics

Kinematics associated with hinges follows a line of development somewhat similar to that of sensor points. Consider the points p and q (refer to Figure II-2) to be two structural hard points associated with a given hinge. All necessary kinematics information pertinent to the hinge is obtained through expressing the velocity of point q relative to point p and in expressing the relative angular velocity between the q and p frames. It is convenient that the angular velocity components are projections onto skew axes (Euler angle rates) and that translational velocity components are projections onto the axes of the p triad. Let us assemble the six relative velocity components into a column matrix as

$$[II-30] \{\dot{\beta}\}_k = \begin{bmatrix} \{\dot{\theta}\} \\ \{\dot{\Delta}\}_k \end{bmatrix}$$

with  $\{\dot{\theta}\}_k$  being the three relative Euler angle rates and  $\{\dot{\Delta}\}_k$  being the three relative translational velocity components all pertaining to the k<sup>th</sup> hinge. Now the column of relative velocities may be expressed as

$$[II-31] \{\dot{\beta}\}_k = [b_p]_k \{U\}_m + [b_q]_k \{U\}_n$$

with

$$[II-32] [b_p] = \begin{bmatrix} -[\pi]^{-1} \begin{bmatrix} R \\ q \\ p \end{bmatrix} \begin{bmatrix} R \\ p \\ m \end{bmatrix} & [0] & -[\pi]^{-1} \begin{bmatrix} R \\ q \\ p \end{bmatrix} \begin{bmatrix} R \\ p \\ m \end{bmatrix} \begin{bmatrix} \sigma \\ p \end{bmatrix} \\ - \begin{bmatrix} R \\ p \\ m \end{bmatrix} \begin{bmatrix} S \\ m \\ p \end{bmatrix}^{(m)} & - \begin{bmatrix} R \\ p \\ m \end{bmatrix} & - \begin{bmatrix} R \\ p \\ m \end{bmatrix} \begin{bmatrix} h \\ p \end{bmatrix} \end{bmatrix}$$

and

$$[II-33] [b_q] = \begin{bmatrix} [\pi]^{-1} \begin{bmatrix} R \\ q \\ n \end{bmatrix} & [0] & [\pi]^{-1} \begin{bmatrix} R \\ q \\ n \end{bmatrix} \begin{bmatrix} \sigma \\ q \end{bmatrix} \\ \begin{bmatrix} R \\ p \\ q \end{bmatrix} \begin{bmatrix} R \\ q \\ n \end{bmatrix} \begin{bmatrix} S \\ n \\ q \end{bmatrix}^{(n)} & \begin{bmatrix} R \\ p \\ q \end{bmatrix} \begin{bmatrix} R \\ q \\ n \end{bmatrix} & \begin{bmatrix} R \\ p \\ q \end{bmatrix} \begin{bmatrix} R \\ q \\ n \end{bmatrix} \begin{bmatrix} h \\ q \end{bmatrix} \end{bmatrix}.$$

In Equations II-82 and II-83 the rotation transformations  $[_p R_m]$  and  $[_q R_n]$  are developed to include the effects of structural deformation in the sense indicated in Equation II-75; the rotation transformations  $[\pi]^{-1}$  and  $[_p R_q]$  are developed in standard fashion using the three Euler rotations  $\{\theta\}_k$ .

NOTE:

Hinge labels are circled;  
body labels are not circled.

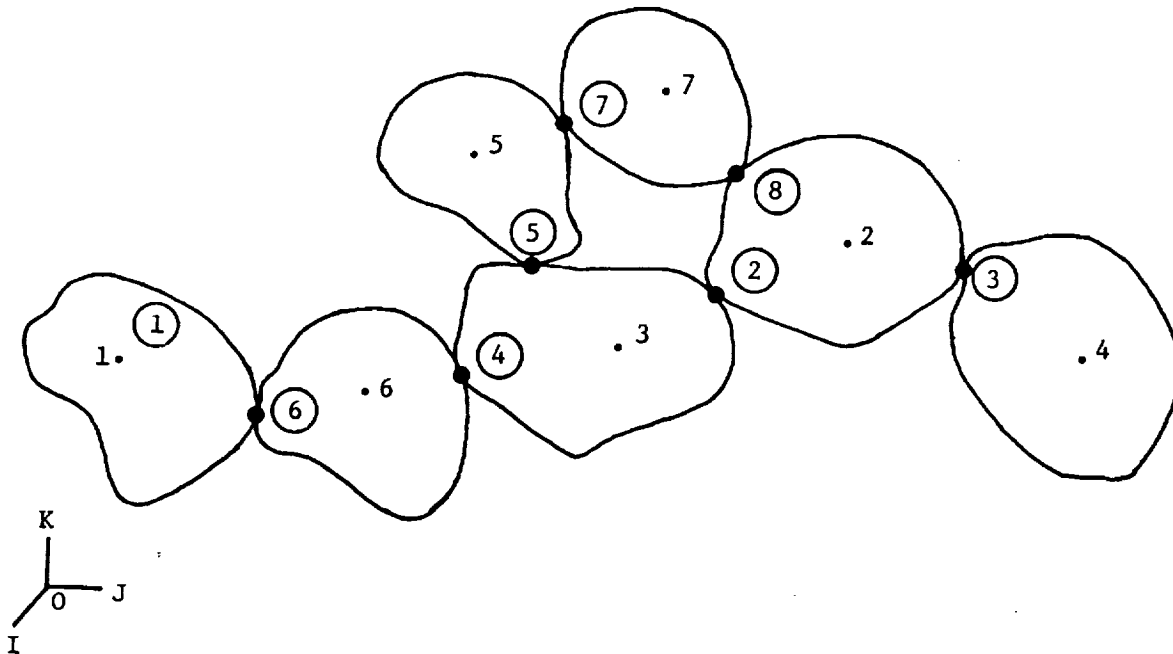

Figure II-3 Topology of a Typical System

For purposes of further discussion, consider the system of bodies of Figure II-3. Topology of the system is simply indicated by an integer array we call ITOPOL, which is as follows:

	1	2	3	4	5	6	7	8	
[ITOPOL] =	1	2	4	3	5	6	7	7	← Hinge number
	0	3	2	6	3	1	5	2	← Body (n) relative to
									← Body (m)

The [ITOPOL] array, which is actual input to the simulation program, is used to define system topology as indicated. Now, with reference to the example shown in Figure II-3 and the corresponding (ITOPOL) array, let us indicate the form of the velocity transformation. We may write

[II-84]

Hinge	Body	(1)	(2)	(3)	(4)	(5)	(6)	(7)
(1)		$b_{q_{1,1}}$						
(2)			$b_{q_{2,2}}$	$b_{p_{2,3}}$				
(3)			$b_{p_{3,2}}$		$b_{q_{3,4}}$			
(4)				$b_{q_{4,3}}$			$b_{p_{4,6}}$	
(5)				$b_{p_{5,3}}$		$b_{q_{5,5}}$		
(6)		$b_{p_{6,1}}$					$b_{q_{6,6}}$	
(7)						$b_{p_{7,5}}$		$b_{q_{7,7}}$
(3)			$b_{p_{8,2}}$					$b_{q_{8,7}}$

$$\begin{bmatrix} \{U\}_1 \\ \{U\}_2 \\ \{U\}_3 \\ \{U\}_4 \\ \{U\}_5 \\ \{U\}_6 \\ \{U\}_7 \\ \{U\}_8 \end{bmatrix} = \begin{bmatrix} \{\dot{\beta}\}_1 \\ \{\dot{\beta}\}_2 \\ \{\dot{\beta}\}_3 \\ \{\dot{\beta}\}_4 \\ \{\dot{\beta}\}_5 \\ \{\dot{\beta}\}_6 \\ \{\dot{\beta}\}_7 \\ \{\dot{\beta}\}_8 \end{bmatrix}$$

where  $[b_{p_{i,j}}]$  and  $[b_{q_{i,j}}]$  are matrices as defined in Equations

II-81 and II-83 (with  $i$ =Hinge number and  $j$ =Body number). The velocity transformations of Equation II-84 represent the "bank" of all hinge kinematics coefficients previously mentioned, and produces every possible velocity component pertinent to hinges. Referring to the basic system equations II-3 and II-5, we note that selected lines, or equations, from the bank (II-84) are taken to represent constraint equations or position coordinate rate equations. The  $[B]_j$  and  $[b]_j$  coefficients of Equations II-3 and II-5 are simply subpartitions extracted from Equation II-84.

To implement calculation of Lagrange's multipliers (refer to Equation II-6) it is necessary to develop time derivatives of  $[b]_j$  coefficients. In a manner similar to above, where all  $[b]_j$  coefficients are extracted from the complete collections, the  $[\dot{b}]_j$  matrices come from a collection of matrices whose members are  $[\dot{b}_{q_{i,j}}]$  and  $[\dot{b}_{p_{i,j}}]$  which are developed in Appendix C.

D. DEVELOPMENT OF THE  $\{G\}_j$  FORCE VECTOR

The equations of dynamic equilibrium for the  $j^{th}$  body of the systems are given in an earlier section as Equations II-1. As was noted there, the right-hand side includes a so-called  $\{G\}_j$  vector, which accounts for all state dependent forces except for those of interconnection constraint. Earlier in Chapter II (Equation II-63), the  $\{G\}_j$  vector is presented in a somewhat more developed form.

The purpose of this section is to provide more explicit development of the elements contributing to  $\{G\}_j$ . Let us account for all contributions in the following expression (we omit the  $j$  subscript, understanding that we are dealing with the typical, or  $j^{th}$  body):

$$\begin{aligned}
 \text{[II-85]} \quad \{G\} = \{G_{ex}\} - \begin{bmatrix} 0 \\ k \end{bmatrix} \{\xi\} - \begin{bmatrix} 0 \\ C \end{bmatrix} \{\dot{\xi}\} + [\tilde{\Omega}] [m] \{U\} \\
 + \frac{1}{2} \left\{ [U] [m, k] \{U\} \right\} - [\dot{m}] \{U\} + \{G_{mw}\} + \{G_{gg}\}.
 \end{aligned}$$

The first term  $\{G_{ex}\}$  has already been discussed in the previous section (See Equation II-74), but we note here that the ordinary force/torque components that produce  $\{G_{ex}\}$  may be thought of as a miscellaneous force vector. Its presence provides the program user latitude to include a variety of additional effects. Clearly, it is the implement through which control forces/torques are "fed back" to the dynamic system.

The second and third terms of Equation II-85 have been previously introduced. There is no implicit restriction on the stiffness and damping matrices  $[k]$  and  $[C]$ , nor is there a restriction on definition of the  $\{\xi\}$  coordinates; they will likely be coordinates associated with orthonormal vibration modes in the majority of cases. However, they may be physical (ordinary-discrete) displacement coordinates as well. In the latter case, the  $[k]$  and  $[C]$  matrices are generally coupled.

The last two terms of Equation II-85 are included to account for momentum wheel coupling and gravity effects respectively. The treatment given to built-in momentum wheels is such that, in addition to producing a contribution to {G}, there is also a required extension to the form of the  $[m]_j$  matrices. This is because momentum wheels are *inertially* coupled. Thus, there is sufficient requirement for a dedicated development concerning momentum wheels. The following two sections deal exclusively with momentum wheel and gravity effects, respectively.

The remaining terms contributing to {G} are basic inertial effects and involve the matrices  $[m]$ ,  $[m]_{,k}$ , and  $[\ddot{m}]$ . With reference to Equation II-39, the form of  $[m]$  is given corresponding to the case where one has single valued space functions  $\bar{\phi}_k$  available to him. Ordinarily, one does *not* have access to such a description of the structure's deformation modes, due to the structural complexity of typical spacecraft. The analyst should always be able to obtain, as data, matrices of modal amplitude ratios ("mode shapes") and the corresponding structural mass matrix (generated by use of finite element techniques). To accommodate data based on the more practical definition of structural characteristics, it is necessary to recast the inertia matrices  $[m]$  in a similar but more general format. The generality of the development of Section II.B is not compromised by extending the form of the inertia matrix. The extended, or more general, inertia matrix is developed in Appendix A, but here, for purposes of developing inertial contributions to the {G} vector, let us accept the resulting form; and present the kinetic energy expression as

$$[II-86] \quad T = \frac{1}{2} [U] \left( [m_0] + [m_1]_j \xi_j + [m_2]_{jk} \xi_j \xi_k \right) \{U\},$$

with the repeated index summation convention implied, and with  $[m_0]$  of the form

$$[II-87] \quad [m_0] = \begin{bmatrix} J & -S & d \\ \hline S & m & a \\ \hline d^T & a^T & e \end{bmatrix}$$

that is it is just like the  $[m]$  given by Equation II-39 except it is constant, independent of deformation. The constant inertia matrix  $[m_0]$ , as given by Equation II-87, is always of the form shown regardless of the choice of "modal" columns. The form of the matrices  $[m_1]$  and  $[m_2]$  is such as to accommodate the general situation; that is, their definition includes inertial integrals as defined for a continuous system, (Equations II-30 through II-37), or as defined by structural mass matrices that are called "lumped" or "consistent."

The inertia matrix associated with  $\xi_j$  is

$$[II-88] [m_1]_j = \begin{bmatrix} 2b_1 & -b_4 & -b_5 & \alpha_1 & \alpha_2 & \alpha_3 & \begin{bmatrix} (C_{yz})_{jk} \\ \end{bmatrix} \\ & 2b_2 & -b_6 & \alpha_4 & \alpha_5 & \alpha_6 & \begin{bmatrix} (C_{zx})_{jk} \\ \end{bmatrix} \\ & & 2b_3 & \alpha_7 & \alpha_8 & \alpha_9 & \begin{bmatrix} (C_{xy})_{jk} \\ \end{bmatrix} \\ \hline & & & 0 & 0 & 0 & \begin{bmatrix} 0 & 0 & 0 \\ 0 & 0 & 0 \\ 0 & 0 & 0 \end{bmatrix} \\ \hline \text{(Symmetric)} & & & & & & \begin{bmatrix} 0 & 0 & 0 \\ 0 & 0 & 0 \\ 0 & 0 & 0 \end{bmatrix} \end{bmatrix}_j$$

and the one associated with  $\xi_j \xi_k$  is

$$[II-89] [m_2]_{jk} = \begin{bmatrix} C_{11} & -C_{12} & -C_{13} & & \\ & C_{22} & -C_{23} & 0 & 0 \\ & & C_{33} & & \\ \hline & & & 0 & 0 \\ \hline \text{(Symmetric)} & & & & 0 \end{bmatrix}_{jk}$$

Now, for  $N$  deformation modes associated with a given body, it is understood that the range of the indices  $j$  and  $k$  is  $N$ , thus the coefficients  $(C_{11})_{jk}$ ,  $(C_{12})_{jk}$ ,  $\dots$ ,  $(C_{xy})_{jk}$  are stored as 9 ( $N \times N$ ) arrays of inertial integrals while  $(b_1)_j$ ,  $(b_2)_j$ ,  $\dots$ ,  $(b_6)_j$  and  $(\alpha_1)_j$ ,  $(\alpha_2)_j$ ,  $\dots$ ,  $(\alpha_9)_j$  are stored as a ( $6 \times N$ ) array and a ( $9 \times N$ ) array respectively. Thus, from a programming standpoint, we



note that there are  $9N^2 + 15N$  storage locations required to accommodate the inertial integrals necessary to account for the deformation dependent mass matrix. Of course, if a particular body is rigid ( $N=0$ ) then only the first (6x6) diagonal partition of  $[m_0]$  is used.

When the body is flexible ( $N>0$ ) then the inertia matrix is calculated from deformation states ( $\xi_j$ ) and inertia integrals in the manner indicated by Equation II-86; the redundant operations due to symmetry and null operations are avoided in the digital code.

Having an instantaneous numerical evaluation of the inertia matrix, the term  $[\dot{\Omega}] [m] \{U\}$  is calculated and added to  $\{G\}$ , consistent with the expression of Equation II-58.

It is now possible to express explicitly, the combination of the remaining two inertial force vectors in terms of the inertial integrals given in Equations II-88 and II-89. For purposes of further development, let us define the combination as

$$[\text{II-90}] \{G_c\} = \left\{ [U] [m, k] \{U\} \right\} - [\dot{m}] \{U\}.$$

Thus, the first element of  $\{G_c\}$ , corresponding to  $\omega_x$  is

$$[\text{II-91}] (G_c)_1 = \left\{ \begin{aligned} & -2\omega_x (b_1)_j + \omega_y (b_4)_j + \omega_z (b_5)_j \\ & -u (\alpha_1)_j - v (\alpha_2)_j - w (\alpha_3)_j \\ & -(C_{yz})_{jk} \dot{\xi}_k - 2\omega_x (C_{11})_{lj} \xi_l \\ & +\omega_y [(C_{12})_{lj} + (C_{12})_{jl}] \xi_l + \omega_z [(C_{13})_{lj} + (C_{13})_{jl}] \xi_l \end{aligned} \right\} \dot{\xi}_j,$$

the second element, corresponding to  $\omega_y$  is

$$[\text{II-92}] (G_c)_2 = \left\{ \begin{aligned} & \omega_x (b_4)_j - 2\omega_y (b_2)_j + \omega_z (b_6)_j \\ & -u (\alpha_4)_j - v (\alpha_5)_j - w (\alpha_6)_j \\ & -(C_{zx})_{jk} \dot{\xi}_k + \omega_x [(C_{12})_{lj} + (C_{12})_{jl}] \xi_l \\ & -2\omega_y (C_{22})_{lj} \xi_l + \omega_z [(C_{23})_{lj} + (C_{23})_{jl}] \xi_l \end{aligned} \right\} \dot{\xi}_j,$$

the third element, corresponding to  $\omega_z$  is

$$\begin{aligned}
\text{[II-93]} \quad (G_c)_3 = & \left\{ \begin{aligned} & \omega_x (b_5)_j + \omega_y (b_6)_j - 2\omega_z (b_3)_j \\ & -u (\alpha_7)_j -v (\alpha_8)_j -w (\alpha_9)_j \\ & -(C_{xy})_{jk} \dot{\xi}_k + \omega_x [(C_{13})_{lj} + (C_{13})_{jl}] \xi_l \\ & + \omega_y [(C_{23})_{lj} + (C_{23})_{jl}] \xi_l - 2\omega_z (C_{33})_{lj} \xi_l \end{aligned} \right\} \dot{\xi}_j ,
\end{aligned}$$

the fourth element, corresponding to  $u$  is

$$\text{[II-94]} \quad (G_c)_4 = - \left\{ \omega_x (\alpha_1)_j + \omega_y (\alpha_4)_j + \omega_z (\alpha_7)_j \right\} \dot{\xi}_j ,$$

the fifth element, corresponding to  $v$  is

$$\text{[II-95]} \quad (G_c)_5 = - \left\{ \omega_x (\alpha_2)_j + \omega_y (\alpha_5)_j + \omega_z (\alpha_8)_j \right\} \dot{\xi}_j$$

and the sixth element, corresponding to  $w$  is

$$\text{[II-96]} \quad (G_c)_6 = - \left\{ \omega_x (\alpha_3)_j + \omega_y (\alpha_6)_j + \omega_z (\alpha_9)_j \right\} \dot{\xi}_j .$$

Finally, for the element  $k+6$ , corresponding to an inertial force acting in the  $\xi_k$  coordinate we have

$$\begin{aligned}
\text{[II-97]} \quad (G_c)_{k+6} = & \omega_x^2 [(C_{11})_{kj} \xi_j + (b_1)_k] \\
& + \omega_y^2 [(C_{22})_{kj} \xi_j + (b_2)_k] \\
& + \omega_z^2 [(C_{33})_{kj} \xi_j + (b_3)_k] \\
& - \omega_x \omega_y \left\{ [(C_{12})_{kj} + (C_{12})_{jk}] \xi_j + (b_4)_k \right\} \\
& - \omega_x \omega_z \left\{ [(C_{13})_{kj} + (C_{13})_{jk}] \xi_j + (b_5)_k \right\} \\
& - \omega_y \omega_z \left\{ [(C_{23})_{kj} + (C_{23})_{jk}] \xi_j + (b_6)_k \right\} \\
& + \omega_x [(\alpha_1)_k u + (\alpha_2)_k v + (\alpha_3)_k w] \\
& + \omega_y [(\alpha_4)_k u + (\alpha_5)_k v + (\alpha_6)_k w] \\
& + \omega_z [(\alpha_7)_k u + (\alpha_8)_k v + (\alpha_9)_k w] \\
& + \left\{ \omega_x [(C_{yz})_{kj} - (C_{yz})_{jk}] + \omega_y [(C_{zx})_{kj} - (C_{zx})_{jk}] \right. \\
& \left. + \omega_z [(C_{xy})_{kj} - (C_{xy})_{jk}] \right\} \dot{\xi}_j .
\end{aligned}$$

From examining the composition of the inertial force  $(G_c)_{k+6}$  we note that the first six bracketed terms represent centrifugal forces (distance  $\times$  omega-squared) acting in the deformation coordinates, while the last bracketed terms of Equation II-97 represents Coriolis forces (velocity  $\times$  omega).

#### E. MOMENTUM WHEEL COUPLING

The spacecraft system undergoing analysis may have several "built-in" momentum wheels. A momentum wheel is generally taken to mean a cylindrical or disk-shaped mass that spins about an axis that is fixed to a structural hard point of a given body. The wheel can be spun up or despun by an electric motor whose rotor is part of the rotating mass. The shaft torque that acts to accelerate the wheel also acts on the body in a negative sense providing active attitude control. The shaft torque is generally governed by a control law that "senses" attitude and rate errors of the body. In this development a momentum wheel is assumed to be inertially symmetric about its spin axis.

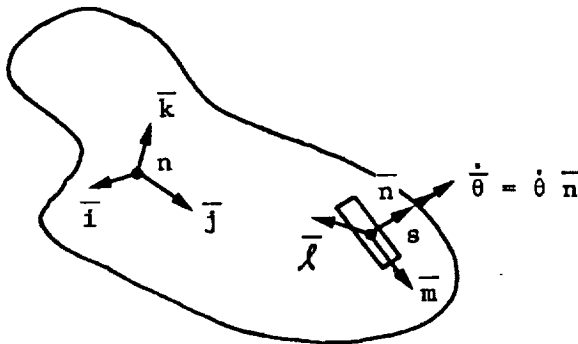

Figure II-4 Typical Body-Momentum Wheel Relationship

To develop the inertial coupling effects of the typical momentum wheel let us consider three unit vector bases:

$$[\text{II-98}] \quad \{\bar{e}_n\} = \{\bar{i}, \bar{j}, \bar{k}\},$$

$$[\text{II-99}] \quad \{\bar{e}_s\} = \{\bar{l}, \bar{m}, \bar{n}\},$$

$$[\text{II-100}] \text{ and } \{\bar{e}_w\} = \{\bar{l}', \bar{m}', \bar{n}'\}.$$

The first triad is the body reference triad for body n, the second is a sensor point triad (fixed to point s), and the third triad is fixed in the momentum wheel. Now, one of the three unit vectors of  $\{\bar{e}_s\}$  is coincident with one of the unit vectors of  $\{\bar{e}_w\}$ ; that is,  $\bar{l}$ ,  $\bar{m}$ , or  $\bar{n}$  may be the spin axis depending on the preference of the analyst. In Figure II-4 we have elected to show  $\bar{n} = \bar{n}'$  as the common, or spin axis.

The absolute angular velocity of the  $\{\bar{e}_w\}$  frame can be expressed as

$$[\text{II-101}] \quad \bar{\omega}_w = \{\bar{e}_w\} [{}^w R_s] \left( \{\omega_s\} + \{P_w\} \dot{\theta} \right)$$

where  $\{P_w\}$  is an elementary 3-long position vector (it is null except for unity in the first, second, or third locations corresponding to  $\bar{l}$ ,  $\bar{m}$ , or  $\bar{n}$  being the spin axis) and  $\dot{\theta}$  is the relative angular speed of the  $\{\bar{e}_w\}$  frame with respect to the  $\{\bar{e}_s\}$  frame.

With the inertial characteristics assumed (axisymmetry) for the wheel, and with the velocity expression of Equation II-101 the total angular momentum vector for the wheel may be written as

$$[\text{II-102}] \quad \bar{h} = \{\bar{e}_w\} [J_w] \{\omega_w\} \\ = \{\bar{e}_s\} [J_w] \left( \{\omega_s\} + \{P_w\} \dot{\theta} \right)$$

with  $[J_w]$  diagonal with all diagonal values equal to  $J_T$  except the position corresponding to the spin axis, which is  $J_s$ :  $J_T$  is the mass moment of inertia about any axis perpendicular to the spin axis and  $J_s$  is the spin inertia for the wheel.

The torque acting on the wheel (resolved to the  $[\bar{e}_s]$  frame) is

$$\begin{aligned}
 \text{[II-103]} \quad \bar{T} &= [e_s] \{T\} = \frac{d}{dt} \bar{h} \\
 &= [e_s] \left( [J_w] \{\dot{\omega}_s\} + \{P_w\} J_s \ddot{\theta} \right. \\
 &\quad \left. - [\Omega_s] [J_w] \{\omega_s\} - [\Omega_s] \{P_w\} J_s \dot{\theta} \right)
 \end{aligned}$$

where we define an SK\* operator such that

$$\begin{aligned}
 &[\Omega_s] = SK^* \{\omega_s\}, \text{ or} \\
 \text{[II-104]} \quad &\begin{bmatrix} 0 & \omega_{s3} & -\omega_{s2} \\ -\omega_{s3} & 0 & \omega_{s1} \\ \omega_{s2} & -\omega_{s1} & 0 \end{bmatrix} = SK^* \begin{bmatrix} \omega_{s1} \\ \omega_{s2} \\ \omega_{s3} \end{bmatrix}.
 \end{aligned}$$

The torque acting on body n at point s, due to the wheel is  $-\bar{T}$  and it drives the body's quasi-coordinate as

$$\begin{aligned}
 \text{[II-105]} \quad \{G_{mw}^r\} &= -[\hat{b}_s]^T \left( [J_w] [\hat{b}_s] \{\dot{U}\}_n + [J_w] [\hat{b}_s] \{U\}_n + \{P_w\} J_s \ddot{\theta} \right. \\
 &\quad \left. - [\Omega_s] [J_w] \{\omega_s\} - [\Omega_s] \{P_w\} J_s \dot{\theta} \right)
 \end{aligned}$$

with

$$\text{[II-106]} \quad [\hat{b}_s] = \begin{bmatrix} R_n \\ s R_n \end{bmatrix} \begin{bmatrix} I & 0 \\ 0 & \sigma_s \end{bmatrix}$$

and also, as can be easily shown,

$$\text{[II-107]} \quad [\dot{\hat{b}}_s] \{U\}_n = [SK^* \left( \begin{bmatrix} R_n \\ s R_n \end{bmatrix} [\sigma_s] \{\dot{\xi}\}_n \right)] [\hat{b}_s] \{U\}_n.$$

Now, the shaft torque is simply the projection of  $\bar{T}$  onto the spin axis, or

$$\begin{aligned}
 \text{[II-108]} \quad T_s &= [P_w] \{T\} \\
 &= J_s [P_w] [\hat{b}_s] \{\dot{U}\}_n + J_s [P_w] [\hat{b}_s] \{U\}_n + J_s \ddot{\theta}.
 \end{aligned}$$

Equations II-105 and II-108 allow us to now express the coupled equations for body n and several momentum wheels as

$$\begin{aligned}
& \left[ \begin{array}{ccc|ccc}
m_n + \hat{b}_1^T J_{w1} \hat{b}_1 + \hat{b}_2^T J_{w2} \hat{b}_2 & \hat{b}_1^T P_{w1} J_{s1} & \hat{b}_2^T P_{w2} J_{s2} & & & \\
\hline
J_{s1} P_{w1}^T \hat{b}_1 & J_{s1} & 0 & & & \\
\hline
J_{s2} P_{w2}^T \hat{b}_2 & 0 & J_{s2} & & & \\
\hline
\end{array} \right] \begin{bmatrix} \{\dot{U}\}_n \\ \ddot{\theta}_1 \\ \ddot{\theta}_2 \end{bmatrix} = \\
& \left[ \begin{array}{c} \{\hat{G}\}_n + [b]_n^T \{\lambda\} \\ \hline 0 \\ \hline 0 \end{array} \right] + \left[ \begin{array}{c} \sum_w [\hat{b}_s]^T [\Omega_s] [J_w] \{\omega_s\} - \sum_w [\hat{b}_s]^T [J_w] [\dot{b}_s] \{U\}_n \\ \hline 0 \\ \hline 0 \end{array} \right] \\
\text{[II-109]} + \left[ \begin{array}{c} - \sum_w [\hat{b}_s]^T (SK^* \{P_w\}) [\hat{b}_s] \{U\}_n J_s \dot{\theta} \\ \hline T_{s1} - J_{s1} \begin{bmatrix} P_{w1} \\ \vdots \end{bmatrix} [\hat{b}_1] \{U\}_n \\ \hline T_{s2} - J_{s2} \begin{bmatrix} P_{w2} \\ \vdots \end{bmatrix} [\hat{b}_2] \{U\}_n \end{array} \right] .
\end{aligned}$$

The inertially coupled body-momentum wheel equations (for two wheels) are shown as Equation II-109 simply for the purpose of indicating the form. One may notice that within the equations, there effectively resides the original form of the dynamic equilibrium equations for body n, namely

$$\text{[II-110]} [m]_n \{\dot{U}\}_n = \{\hat{G}\}_n + [b]_n^T \{\lambda\}$$

which govern in the event that there are no momentum wheels associated with body n. In Equation II-110 we have placed the caret (^) over G to represent the right-hand side force vector excluding momentum wheel effects.

Now, on further study of the form of the Equations II-109, we note that if the "locked" momentum wheel effects are already included in the definition of  $[m]_n$  (which is the standard practice when inertially coupling systems together), then the (1, 1) partition of the coefficients on the left of Equation II-109 becomes simply  $[m]_n$ . Also, the second column on the right of Equation II-109 is absorbed in  $\{\hat{G}\}_n$ , having already been accounted for in development of dynamic equilibrium equations.

Thus, it follows that in order to implement momentum wheel coupling with one of the flexible bodies, it is only necessary to extend the  $\{U\}_n$  vector to contain momentum wheel spin values

$(\dot{\theta})$ , to extend the inertia (except for the [1, 1] partition) as indicated in Equation II-109 and to add to the right-hand side force vector

$$[\text{II-111}] \{G_{mw}\} = - \left[ \begin{array}{c} \sum_w \{ \hat{b}_s \}^T (SK^* \{P_w\}) \{ \hat{b}_s \} \{U\}_n J_s \dot{\theta} \\ \hline T_{s1} - J_{s1} \begin{bmatrix} P_{w1} \\ \hat{b}_1 \end{bmatrix} \{U\}_n \\ \hline T_{s1} - J_{s2} \begin{bmatrix} P_{w2} \\ \hat{b}_2 \end{bmatrix} \{U\}_n \end{array} \right].$$

The values for shaft torque  $T_s$  that appear in  $\{G_{mw}\}$  are established by a given control law, if the wheels are to be considered variable speed. If a given momentum wheel is of constant speed (used only for "gyroscopic damping") then the torque equation for it is deleted from the form of Equation II-109; however, its effects are still included in the upper partition of the vector  $\{G_{mw}\}$  (the gyroscopic torque due to constant  $\dot{\theta}$ ).

Clearly, the equations of dynamic equilibrium for a body, after having been augmented to include momentum wheel coupling, are still of the general form

$$[\text{II-112}] \{\dot{U}\}_j = [m]_j^{-1} \left( \{G\}_j + [b]_j^T \{\lambda\} \right).$$

F. GRAVITY GRADIENT EFFECTS

Attitude dynamics of orbiting spacecraft can be significantly influenced by the gravitational force that is distributed according to the system's position and deformation state. The gravitational force per unit mass varies (in a central force field) simply because different mass particles are at different distances from the earth's mass center. Figure II-5 describes the geometry associated with a typical elastic body.

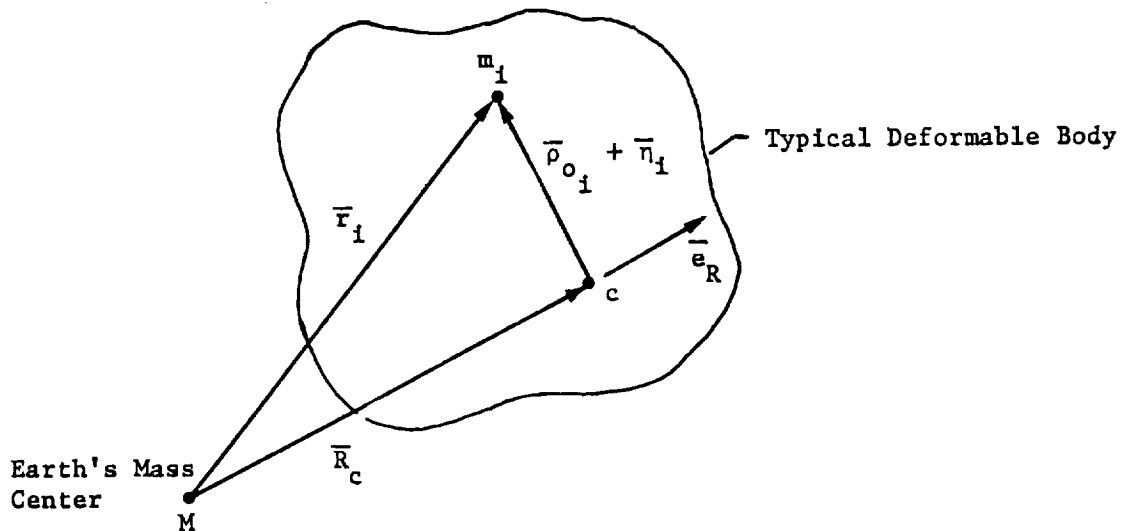

Figure II-5 Geometry for Gravity Effects on a Typical Body

For a central force field, the gravitational force per unit mass is given as

$$[II-113] \quad \left( \frac{\bar{F}}{m} \right)_i = - \frac{GM}{r_i^2} \frac{\bar{r}_i}{r_i},$$

which, to a first order approximation, is

$$[II-114] \quad \left( \frac{\bar{F}}{m} \right)_i = - g_c \left[ \bar{e}_R + \frac{\bar{\rho}_{o_i} + \bar{\eta}_i}{R_c} - 3 \bar{e}_R \left( \bar{e}_R \cdot \frac{\bar{\rho}_{o_i} + \bar{\eta}_i}{R_c} \right) \right]$$

where  $GM$  is the Earth's gravitational constant,

$m_i$  is the typical mass particle,

$g_c$  is local gravitational acceleration

$\bar{e}_R$  is a unit vector directed along  $\bar{R}_c$

and  $c$  is the origin of the body reference system.



The virtual work due to gravitational force can be written as

$$\delta W_g = \sum_i \left( \frac{\bar{F}}{m} \right)_i \cdot \delta \bar{r}_i m_i$$

[II-115] 
$$= \int_V \left( \frac{\bar{F}}{m} \right) \cdot \delta \bar{r} \sigma dV$$

with  $m_i$  replaced by differential mass  $\sigma dV$ .

The virtual displacement field is expressed in terms of virtual displacements of the quasi-coordinates as

[II-116] 
$$\delta \bar{r} = \delta \bar{r}_c + \delta \bar{\theta}_c \times (\bar{\rho}_0 + \bar{\eta}) + \delta \bar{\eta}.$$

In combining Equation II-115 with Equation II-116, the torque about point c, due to gravity gradient effects, is

[II-117] 
$$\left( \bar{T}_c \right)_g = g_c \bar{e}_R \times \bar{S} + \frac{3g_c}{R_c} \bar{e}_R \times \left( \bar{J} \cdot \bar{e}_R \right)$$

where  $\bar{S}$  is the first mass moment about point c,

and  $\bar{J}$  is the instantaneous inertia tensor (deformation dependent) for the body.

The resultant force due to gravity effects is

[II-118] 
$$\left( \bar{F}_c \right)_g = -g_c m \bar{e}_R - \frac{g_c}{R_c} \bar{S} + \frac{3g_c}{R_c} \left( \bar{e}_R \cdot \bar{S} \right) \bar{e}_R$$

and the force acting in the kth deformation coordinate,  $\xi_k$ , is

$$\left( G_{\xi_k} \right)_g = -g_c \left\{ \int_V \bar{\phi}_k \cdot \bar{e}_R \sigma dV + \frac{1}{R_c} \int_V \bar{\phi}_k \cdot (\bar{\rho}_0 + \bar{\eta}) \sigma dV \right.$$

[II-119] 
$$\left. - 3 \frac{\bar{e}_R}{R_c} \cdot \int_V \bar{\phi}_k \left[ \bar{e}_R \cdot (\bar{\rho}_0 + \bar{\eta}) \right] \sigma dV \right\}.$$

Now, the unit vector  $\bar{e}_R$  has projections onto the body axis system that continually vary as the body changes attitude. Let us express the unit vector  $\bar{e}_R$  in terms of direction cosines and the three unit vectors associated with the body reference frame as

$$[\text{II-120}] \quad \bar{e}_R = [\bar{e}_B] \{ \gamma_g \}$$

and also define

$$[\text{II-121}] \quad [\tilde{\gamma}_g] = SK^* \{ \gamma_g \},$$

$$[\text{II-122}] \quad \bar{s} = [\bar{e}_B] \{ s \},$$

$$[\text{II-123}] \quad [\tilde{s}] = SK^* \{ s \},$$

$$[\text{II-124}] \quad \text{and} \quad \{ a \}_k = \int_V \{ \phi \}_k \sigma dV.$$

With these definitions and the force and torque expressions of Equations II-117, II-118, and II-119, it follows that the first three elements of the contribution to the right-hand force vector, due to gravity effects are:

$$[\text{II-125}] \quad \{ G_{gg} \}_{1,2,3} = g_c [\tilde{s}] \{ \gamma_g \} - \frac{3g_c}{R_c} [\tilde{\gamma}_g] [J] \{ \gamma_g \},$$

the second three elements are

$$[\text{II-126}] \quad \{ G_{gg} \}_{4,5,6} = -g_c^m \{ \gamma_g \} + \frac{g_c}{R_c} \left( 3 \{ \gamma_g \} [\gamma_g] - [I] \right) \{ s \},$$

and the force, due to gravity, acting in the kth deformation mode is

$$\begin{aligned} G_{\xi_k} = & -g_c [\gamma_g] \{ a \}_k - \frac{g_c}{R_c} \left[ \frac{(b_1)_k + (b_2)_k + (b_3)_k}{2} + e_{kj} \xi_j \right] \\ & + \frac{3g_c}{2R_c} \left\{ \left( 1 - 2\gamma_{g1}^2 \right) \left[ (b_1)_k + (c_{11})_{kj} \xi_j \right] \right. \\ & \left. + \left( 1 - 2\gamma_{g2}^2 \right) \left[ (b_2)_k + (c_{22})_{kj} \xi_j \right] \right\} \end{aligned}$$

$$\begin{aligned}
& + \left(1 - 2\gamma_{g3}^2\right) \left[ (b_3)_k + (C_{33})_{kj} \xi_j \right] \\
& + 2\gamma_{g1} \gamma_{g2} \left[ (b_4)_k + (C_{12})_{kj} \xi_j + (C_{12})_{jk} \xi_j \right] \\
& + 2\gamma_{g1} \gamma_{g3} \left[ (b_5)_k + (C_{13})_{kj} \xi_j + (C_{13})_{jk} \xi_j \right] \\
\text{[II-127]} \quad & + 2\gamma_{g2} \gamma_{g3} \left[ (b_6)_k + (C_{23})_{kj} \xi_j + (C_{23})_{jk} \xi_j \right] \left. \vphantom{\begin{aligned} & + \left(1 - 2\gamma_{g3}^2\right) \left[ (b_3)_k + (C_{33})_{kj} \xi_j \right] \\ & + 2\gamma_{g1} \gamma_{g2} \left[ (b_4)_k + (C_{12})_{kj} \xi_j + (C_{12})_{jk} \xi_j \right] \\ & + 2\gamma_{g1} \gamma_{g3} \left[ (b_5)_k + (C_{13})_{kj} \xi_j + (C_{13})_{jk} \xi_j \right] \right\}
\end{aligned}
\right.
\end{aligned}$$

where the inertia integrals  $(b_n)_k$ ,  $(n = 1, 2, \dots, 6)$ , and  $(C_{\ell m})_{kj}$ ,  $(\ell, m = 1, 2, 3)$ , are consistent with the development of Chapter II, Section D and Appendix A.

#### G. PROVISION FOR INCLUSION OF THERMAL ENVIRONMENTS

All problems associated with thermally-induced deflections have in common the requirement of knowing the spacecraft's attitude relative to the sun to determine the effect of solar heating. This required information can be extracted, at any point in time, from the state vector. It is then necessary to have a model of the flexible structure's response, either static or dynamic, to solar heating.

Considerable work has been done on modeling flexible appendages in thermal environments\* and the results indicate that the response

---

\*For example, refer to:

- 1) Fixler, S. Z., "Effects of Solar Environment and Aerodynamic Drag on Structural Booms in Space." *J. Spacecraft*, Vol 4, No. 3, March 1967,
- 2) Frisch, H. P., "Coupled Thermally-Induced Transverse Plus Torsional Vibrations of a Thin-Walled Cylinder of Open Sections," NASA TR R-333, March 1970.
- 3) Goldman, R. L., "Influence of Thermal Distortion on the Anomalous Behavior of a Gravity Gradient Satellite," AIAA Paper 74-922, AIAA Mechanics and Control of Flight Conference, Anaheim, California, August 1974.

depends on the radiation properties of the booms and the attitude relative to the sun.

The simulation program accounts for time-dependent thermal deformations in the following manner. It is assumed that a model exists whereby the structural deformation of a flexible boom (or appendage) resulting from solar heating can be determined from elements of the state vector and time. This deformation is subtracted from the actual deformation; the difference is premultiplied by the appendage stiffness matrix. The result is a vector of modified, generalized restoring forces for the appendage, which is summed into the  $\{G\}_j$  vector for the appendage body.

In terms of the development in Sections II.B and II.D where  $-[k]\{\xi\}$  is seen to be the generalized restoring forces (in the deformation coordinates), we note that this is replaced with  $-[k](\{\xi\} - \{\xi_e\})$ . The thermal deformation state  $\{\xi_e\}$  is that which must be established from a thermal deformation model.

In this way, a closed loop response analysis can be achieved using external subroutines to develop the thermal deformations. Some problems may require only open loop operation if the variations of  $\{\xi_e\}$  in time is slow with respect to general dynamic response.

Rather than building in a rigid (or irrevocable) model of thermal deformation, the dynamic simulation program provides the user with an interface whereby he can formulate and code a particular model, thus latitude with respect to user requirements is retained.

### III. SYNTHESIS AND ANALYSIS OF THE LINEARIZED SYSTEM

---

Developments to this point have described the analytical techniques used to synthesize the nonlinear characteristics of a dynamical system consisting of an assembly of interconnected flexible (or rigid) bodies. Particular emphasis has been placed on spacecraft systems where individual bodies that comprise the system may be spinning or nonspinning and may have large excursions with respect to each other.

In this chapter we present a comprehensive summary of the techniques developed for synthesis and analysis of the linearized dynamic system with particular emphasis on frequency domain techniques. For the purposes of this discussion it has been found to be convenient to redefine the nature of the system under consideration and to describe the techniques not in the sense of a spacecraft system consisting of interconnected bodies that may be subjected to a control system but rather to consider the total dynamic system as a *plant* subject to a *controller*.

Linearization of the nonlinear state equations is necessary to permit application of the powerful analytical techniques associated with linear system stability synthesis. Whenever a nonlinear system can be reduced to a linear system in the vicinity of a particular state of interest, it is much more desirable to work with the linearized state equations. An additional feature related to the linearized system permits the analyst to observe linearized perturbation time response characteristics for the system. The linearized time response can be quite easily automated by recursive formula, which are generally more efficient than nonlinear numerical integration algorithms.

A. INTRODUCTORY DISCUSSION

The mainline nonlinear time domain analysis is structured to assemble a collection of interconnected bodies, including a control law. The general form of the governing equations may be concisely indicated as

$$[\text{III-1}] \dot{Y}^i = F(Y^i, t) \quad i = 1, 2, \dots$$

and the form of the function  $F$  is the essence of the nonlinear time domain solution. In fact, it can be stated that Equation III-1 is the fundamental basis for the entire DISCOS program. Algorithms for evaluating the nonlinear state vector time derivatives (and auxiliary equations) are centered in a subprogram and its supporting routines. These same functional algorithms are used for linearizing the governing equations about a specified state. In addition, it has been found desirable to introduce some new variables including sensor signals,  $X_{SS}$ , and control

torques,  $B$ . These new variables extend the number of equations and these additional expressions are linearized along with the basic state equations. Additional remarks concerning the use and manipulation of the additional variables is deferred for a later section. The remainder of this subsection will address specifics relating to the linearization process.

We first focus our attention on a single variable,  $\dot{y}_k$ , and its dependence on the system state,  $Y^1$ , through a known (though possibly nonlinear) functional relationship. Arguments begin by considering an initial system state,  $Y^1(0)$ , and a functional algorithm with which to evaluate the expression,  $\dot{y}_k = \frac{d}{dt} Y_k$ . We first express the unknown,  $\dot{y}_k$ , in terms of a Taylor's series expansion about the given state,  $Y^1(0)$  as

$$[\text{III-2}] \dot{y}_k = \dot{y}_k(0) + \frac{\partial \dot{y}_k}{\partial Y^j} dY^j + \frac{\partial^2 \dot{y}_k}{\partial Y^j \partial Y^l} dY^j dY^l + \dots$$

As our interest lies in the linear part only, the series is truncated for all partial derivatives greater than one and we have

$$[\text{III-3}] \dot{y}_k - \dot{y}_k(0) = \frac{\partial \dot{y}_k}{\partial Y^j} dY^j = \dot{y}_{k,j} dY^j$$

The task at hand then is to establish the partial derivatives indicated as  $\dot{y}_{k,j}$ , thus yielding an expression of the form (for all  $\Delta \dot{Y}^i = \dot{Y}^i - \dot{Y}^i(o)$ ,  $i = 1, 2, \dots$ )

$$[\text{III-4}] \Delta \dot{Y}^i = H_{i,j} \Delta Y^j$$

Because it would be a nearly impossible (certainly impractical) task to generalize determination of the partial derivatives as explicit analytical expressions involving the independent state variables, we have adopted a numerical approach. This task is accomplished by employing numerical perturbation techniques in conjunction with quadratic functions to establish the desired partial derivatives. Symbolically, we seek to determine the elements of  $H_{i,j}$  such that

$$[\text{III-5}] \dot{Y}^i = \dot{Y}^i(o) + H_{i,j} \Delta Y^j$$

where it is assumed that

- 1) The functions,  $\dot{Y}^i$ , are indeed linear sufficiently near the state,  $Y^i(o)$
- 2) The functions,  $\dot{Y}^i$ , (although possibly nonlinear) can be represented as a quadratic (or lower order) in the neighborhood of  $Y^i(o)$ .

The basic approach is concisely summarized in two steps:

- 1) Establish quadratic coefficients for  $\dot{Y}^i$  in the vicinity of the state,  $Y^i(o)$
- 2) Evaluate the partial derivatives  $H_{i,j}$  at the state,  $Y^i(o)$ , using the quadratic coefficients and perturbation values on the independent variables.

## B. THE LINEARIZATION PROCESS

With reference to Figure III-1, the quadratic formula can be stated in matrix form as

$$[\text{III-6}] f(\eta) = \begin{bmatrix} \eta^2 & \eta & 1 \end{bmatrix} \begin{Bmatrix} d \\ e \\ f \end{Bmatrix}$$

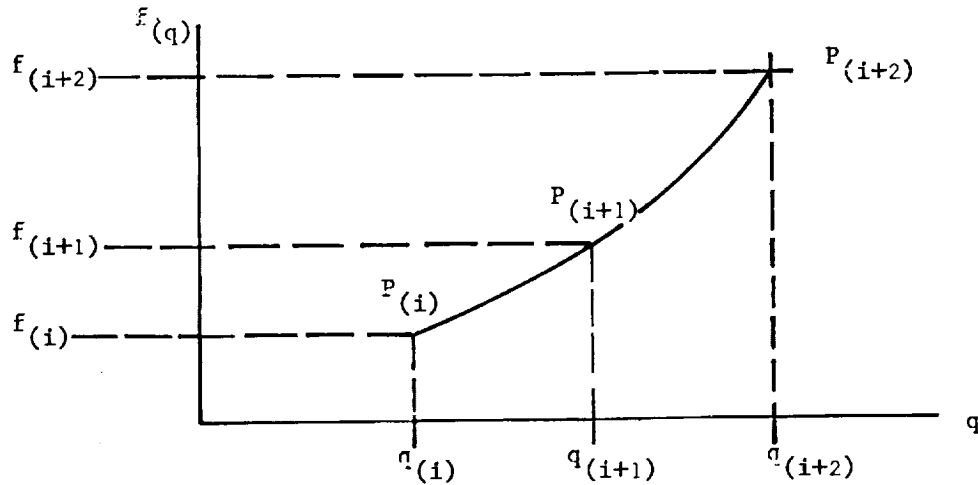

Figure III-1 The Quadratic Formula

where  $\eta$  is a local spacial coordinate with origin corresponding to  $q_{(i)}$  and it is desired to establish the derivative,  $\frac{\partial f}{\partial q}$ , evaluated at  $q_{(i)}$ .

In general, the required partial derivative is

$$[\text{III-7}] \quad \frac{\partial f}{\partial q} = \frac{\partial f}{\partial \eta} \frac{\partial \eta}{\partial q}$$

The three values,  $f_{(i)}$ ,  $f_{(i+1)}$ ,  $f_{(i+2)}$ , are evaluated via the previously discussed functional algorithm, thus these values do in fact satisfy Equation III-6. More specifically, consider

$$[\text{III-8}] \quad \begin{Bmatrix} f_i \\ f_{i+1} \\ f_{i+2} \end{Bmatrix} = \begin{bmatrix} \eta_i^2 & \eta_i & 1 \\ \eta_{i+1}^2 & \eta_{i+1} & 1 \\ \eta_{i+2}^2 & \eta_{i+2} & 1 \end{bmatrix} \begin{Bmatrix} d \\ e \\ f \end{Bmatrix}$$

and by matrix manipulation it follows that

$$[\text{III-9}] \quad f(\eta) = \begin{bmatrix} \eta^2 & \eta & 1 \end{bmatrix} \begin{bmatrix} \eta_i^2 & \eta_i & 1 \\ \eta_{i+1}^2 & \eta_{i+1} & 1 \\ \eta_{i+2}^2 & \eta_{i+2} & 1 \end{bmatrix}^{-1} \begin{Bmatrix} f_i \\ f_{i+1} \\ f_{i+2} \end{Bmatrix}$$

where the local coordinate,  $\eta$ , is defined to be



$$[\text{III-10}] \quad \eta = \frac{q - q_i}{q_{i+2} - q_i}$$

and it can be noted that

$$[\text{III-11}] \quad \eta_i = 0; \quad \eta_{i+2} = 1; \quad \frac{\partial \eta}{\partial q} = \frac{1}{q_{i+2} - q_i}.$$

It then follows that

$$[\text{III-12}] \quad f(n) = \begin{bmatrix} n^2 & n & 1 \end{bmatrix} \begin{bmatrix} 0 & 0 & 1 \\ \eta_{i+1}^2 & \eta_i & 1 \\ 1 & 1 & 1 \end{bmatrix}^{-1} \begin{pmatrix} f_i \\ f_{i+1} \\ f_{i+2} \end{pmatrix}$$

and if we specify  $\eta_{i+1} = 1/2$  and note that  $f_{(i)} = f_{(n=i)}$  we have

$$[\text{III-13}] \quad f(n) = \begin{bmatrix} n^2 & n & 1 \end{bmatrix} \begin{bmatrix} 0 & 0 & 1 \\ 1/4 & 1/2 & 1 \\ 1 & 1 & 1 \end{bmatrix}^{-1} \begin{pmatrix} f_{(0)} \\ f_{(1/2)} \\ f_{(1)} \end{pmatrix},$$

$$[\text{III-14}] \quad f(n) = \begin{bmatrix} n^2 & n & 1 \end{bmatrix} \begin{bmatrix} 2 & -4 & 2 \\ -3 & 4 & -1 \\ 1 & 0 & 0 \end{bmatrix} \begin{pmatrix} f_{(0)} \\ f_{(1/2)} \\ f_{(1)} \end{pmatrix},$$

$$[\text{III-15}] \quad f'(n) = \begin{bmatrix} 2n & 1 & 0 \end{bmatrix} \begin{bmatrix} 2 & -4 & 2 \\ -3 & 4 & -1 \\ 1 & 0 & 0 \end{bmatrix} \begin{pmatrix} f_{(0)} \\ f_{(1/2)} \\ f_{(1)} \end{pmatrix},$$

and, in particular,

$$[\text{III-16}] \quad \left. \frac{\partial f}{\partial n} \right|_{(0)} = f'_n (n=0) = e,$$

and

$$[\text{III-17}] \quad \left. \frac{\partial f}{\partial q} \right|_{(0)} = f'_q (q=q_i) = \frac{e}{q_{(i+2)} - q_{(i)}}.$$

1. Comments

Selection of an initial perturbation value,  $q(i+2)$ , from an initial specified state,  $q(o) = Y_k(o)$ , is somewhat arbitrary. A value of 1% of the initial value has been successfully used for all example problems during the course of the study. In the case where the initial value is null, an infinitesimal value must be chosen. A value of  $1 \times 10^{-5}$  has been accommodated in the digital code. The intermediate choice of  $\eta(i+1) = 1/2$  was selected for other reasons. Consider first that a single evaluation of a partial derivative  $\frac{\partial f}{\partial Y^i}$  is not sufficient to qualify its validity.

We have employed an approach whereby two successive evaluations of  $\partial f / \partial Y^i$  obtained by successively cutting the perturbation in half must agree to a predetermined number of significant digits (e.g., 5). The choice of  $\eta(i+1) = 1/2$  requires but a single new evaluation for each element in  $\dot{Y}^i$  at each successive reduction in the perturbation value. In summary, the linearization employs an iterative technique to establish the desired partial derivatives.

2. System Resonance Properties

The linearization process has provided a system of first order differential equations that describe the dynamical simulation in terms of perturbation variables about an equilibrium state. The linearized canonical form appears as

$$[\text{III-18}] \dot{\Delta Y}^i = H_{i,j} \Delta Y^j \quad (i, j = 1, 2, \dots)$$

The coefficients  $H_{i,j}$  contain all of the resonance frequency properties of the dynamical system. The standard eigensolution form is indicated by taking the transform of this expression

$$[\text{III-19}] \left( \delta_i^j s - H_{i,j} \right) \Delta Y^j(s) = 0.$$

Extraction of the roots (eigenvalues) from  $H_{i,j}$  then gives the roots of the dynamical system. There will be  $N$  of these roots and any complex roots will appear as conjugate pairs because the elements of  $H_{i,j}$  are all real. The imaginary part of the complex pairs represents the resonance (or characteristic) frequencies of the system.

C. EXCHANGE OF VARIABLES

It is often necessary for the analyst to require additional variables with which to assess the stability characteristics of the dynamical system. These additional variables ordinarily take the form of plant sensor signals and control system output forces and torques. Although the desired variables may not be explicitly contained in the system state vector,  $Y^i$ , they are known in terms of the state variables through an expression of the form

$$[\text{III-20}] \quad w^j = g(Y^i).$$

Recall also from previous discussions that either directly or through linearization we have established

$$[\text{III-21}] \quad \Delta \dot{Y}^i = H_{i,j} \Delta Y^j$$

Now rewriting Equation III-20 in matrix form and identifying variables to retain,  $Y_1$ , and variables to eliminate,  $Y_2$ , gives

$$[\text{III-22}] \quad \{w\} = \begin{bmatrix} C_1 & | & C_2 \end{bmatrix} \begin{Bmatrix} Y_1 \\ Y_2 \end{Bmatrix}$$

and it can readily be established that

$$[\text{III-23}] \quad \{Y\} = [R] \{Z\}$$

where

$$[R] = \begin{bmatrix} I & | & 0 \\ -C_2^{-1}C_1 & | & C_2^{-1} \end{bmatrix}$$

and

$$\{Z\} = \begin{Bmatrix} Y_1 \\ w \end{Bmatrix}.$$

Thus, the state equations for the dynamical system can be written (in terms of variables that include the desired plant sensor signals and control system forces and torques) as

$$[\text{III-24}] \quad \{\dot{Z}\} = [R]^{-1} [H_{i,j}] [R] \{Z\}.$$

and the transformation  $A_{ij} = R^{-1} H_{i,j} R$ , is commonly referred to as a similarity transformation. The matrix  $A_{ij}$  is said to be the transform of  $H_{i,j}$  by the matrix  $R$ .\*

The similarity transformation  $A_{ij}$  possesses a unique property in that the eigenvalues of  $A_{ij}$  are equal to the eigenvalues of  $H_{i,j}$ ! A simple proof establishes this point.

Proof:

The characteristic matrix of  $A_{ij}$  is given by

$$\text{[III-25]} \quad (A_{ij} - sI) = (R^{-1} H_{i,j} R - sI) = R^{-1} (H_{i,j} - sI) R.$$

It follows that  $Q(s)$ , the characteristic polynomial of  $A_{ij}$ , is

$$Q(s) = \det (A_{ij} - sI) = \det R^{-1} \left( \det (H_{i,j} - sI) \right) \det R$$

and as  $(\det R^{-1}) = \frac{1}{\det(R)}$  it is apparent that

$$Q(s) = \det (H_{i,j} - sI) = P(s)$$

where  $P(s)$  is the characteristic polynomial of  $H_{i,j}$ . Thus it is evident that the matrices  $H_{i,j}$  and  $A_{ij}$  have the same characteristic equations

$$Q(s) = P(s) = 0$$

and therefore, the eigenvalues of  $A_{ij}$  are equal to the eigenvalues of  $H_{i,j}$ .

Application of this property now permits isolation of the plant and controller, even for a state space representation of an inherently nonlinear system that can be linearized about a specified state. Separation of plant and control system variables is an important facet of linear system stability synthesis.

---

\*S. Hovanessian and L. A. Pipes: *Digital Computer Methods in Engineering*, McGraw-Hill Book Company, New York, 1969.

1. Evaluation of the Similarity Transformation

This discussion relates to a procedural approach for determination of the similarity transformation matrix,  $[R]$ , that will relieve the user from the burden of having to select those variables to eliminate from the original state vector such that the auxiliary variables,  $B^i$  and  $X_{ss}^i$ , can become an independent constituent of the modified state vector for use in the linearized studies. With reference to Equation III-22, all of the  $C_{ij}$  coefficients are known as they have been obtained through linearization of the auxiliary equations. The  $C_{ij}$  coefficients simply define the dependence of the auxiliary variables,  $w^j$ , on the original state variables,  $Y^i$ . In general, it is not possible to directly partition the  $C_{ij}$  in the  $C_1$  and  $C_2$  partitions as indicated in Equation III-22, for we have yet not made the decision as to which state variables to retain and which ones to discard in preference to introduction of the auxiliary variables,  $w^j$ . In this light we would like to make a *best possible* choice with regard to which of the variables to eliminate from the state vector,  $Y^i$ , such that the auxiliary variables,  $w^j$ , may be included. Many times there will be a one to one variable exchange between an element of  $w^j$  and an element of  $Y^i$ . In any case a variable exchange is necessary to structure the total system into the desired plant/controller framework whereby the plant and controller can be isolated along with the plant sensor signals and the control system inputs.

The following approach is employed in this simulation to accomplish the desired result; namely, an optimum selection from  $Y^i$  as to which variables to eliminate such that  $w^j$  can be introduced as a part of the state vector. With reference to Equation III-22 we can write

$$[\text{III-26}] \quad \left[ C \mid -I \right] \begin{Bmatrix} Y^i \\ w^j \end{Bmatrix} = \{0\}.$$

Our primary focus of attention is now directed to a systematic examination of the  $C_{ij}$  coefficients such that the variable exchange is accomplished in an optimum manner. We will first make note of some size identifications to help clarify the discussion.

$C_{ij}$  has size NR by NS

$Y^i$  has size NS by 1

$w^j$  has size NR by 1

and

$$NJQ = NS + NR.$$

Clearly, there exists at least one nonzero element in each row of the  $C_{ij}$  array. Otherwise  $Y^i$  does not represent an independent set.

Now a search through the first NS elements of row 1 in the matrix array

$$[\text{III-27}] \left[ C \mid -I \right]$$

will identify the largest element (absolute value) in row 1. Assuming that this element occurs in column JBIG ( $1 \leq \text{JBIG} \leq \text{NS}$ ) allows us to divide each element of row 1 by this largest element and subsequent elementary row operations on rows 1 through NR will eliminate those elements below the pivotal element in column JBIG.

This procedure is repeated for each of the NR rows contained in the matrix and the following observations are noted;

- 1) the appearance of a one (1.0) in a row identifies a variable that will be eliminated in preference to inclusion of an element of  $w^j$ .
- 2) The absence of a zero or one in columns of a given row indicates which variables will survive the exchange process.
- 3) All variables in  $w^j$  (NR of them) will become part of a new and independent state vector (the modified state vector).
- 4) The transformation,  $R_{ij}$  ( $i, j = 1 \dots \text{NS}$ ) can be constructed from the matrix that remains after the procedural approach has exhausted all of the NR rows of the expression III-27.

## 2. Illustrative Example

A simple example is presented to further describe the actual mechanics used for evaluation of the similarity transformation. Linearization of the auxiliary equations has established

$$\begin{Bmatrix} w_1 \\ w_2 \end{Bmatrix} = [C] \begin{Bmatrix} Y_1 \\ Y_2 \\ Y_3 \\ Y_4 \end{Bmatrix}$$

and to implement the proposed algorithm, we first write down the C matrix augmented with -I and further identify the elements of C as

$$\left[ \begin{array}{cccc|c} \text{NS} & & & & 2 \\ \hline C & & & & -I \end{array} \right] = \left[ \begin{array}{cccc|c} b_{11} & b_{12} & b_{13} & b_{14} & -1 \\ b_{21} & b_{22} & b_{23} & b_{24} & -1 \end{array} \right].$$

For illustrative purposes assume that  $|b_{13}| > |(b_{11}, b_{12}, b_{14})|$  and hence  $b_{13}$  is the pivotal element for the first row. It follows then that row 2 is modified by the relation

$$\text{ele}_{2j} = \frac{-b_{23} * b_{1j}}{b_{13}} + b_{2j}$$

giving the matrix

$$\left[ \begin{array}{cc|c|c|c|c} b_{11} & b_{12} & 1 & b_{14} & -\frac{1}{b_{13}} & 0 \\ \hline -b_{23} & b_{11} & -b_{23} & b_{12} & -b_{23} & b_{14} \\ & b_{13} & b_{13} & b_{13} & b_{13} & b_{13} \\ & +b_{21} & +b_{22} & +b_{24} & \frac{b_{23}}{b_{13}} & -1 \end{array} \right]$$

$$= \left[ \begin{array}{cc|c|c|c|c} c_{11} & c_{12} & 1 & c_{14} & c_{15} & 0 \\ \hline c_{21} & c_{22} & 0 & c_{24} & c_{25} & -1 \end{array} \right].$$

We continue the process by first dividing row 2 by the largest element and again using row operations to eliminate the other element in that column. Again, for illustrative purposes, we will assume we know the pivotal element of row 2 (say  $c_{22}$ ) and row 1 will be modified as follows by row operations

$$\text{ele}_{1j} = \frac{-c_{12} * c_{2j}}{c_{22}} + c_{1j}$$

giving

$$d_{ij} = \left[ \begin{array}{cc|c|c|c|c} -c_{12} & \frac{c_{21}}{c_{22}} & 0 & 1 & -c_{12} & \frac{c_{24}}{c_{22}} & -c_{12} & \frac{c_{25}}{c_{22}} & \frac{c_{12}}{c_{22}} \\ +c_{11} & c_{22} & & & +c_{14} & c_{22} & +c_{15} & c_{22} & \\ \hline \frac{c_{21}}{c_{22}} & & 1 & 0 & \frac{c_{24}}{c_{22}} & & \frac{c_{25}}{c_{22}} & & -\frac{1}{c_{22}} \end{array} \right]$$

$$= \left[ \begin{array}{cc|c|c|c|c} d_{11} & 0 & 1 & d_{14} & d_{15} & d_{16} \\ \hline d_{21} & 1 & 0 & d_{24} & d_{25} & d_{26} \end{array} \right]$$

from which we establish the desired similarity transformation as

$$R_{ij} = \begin{bmatrix} 1 & 0 & 0 & 0 \\ -d_{21} & -d_{24} & -d_{25} & -d_{26} \\ -d_{11} & -d_{14} & -d_{15} & -d_{16} \\ 0 & 1 & 0 & 0 \end{bmatrix}.$$

Now it follows that the original state variables are written in terms of the modified state variables as

$$\begin{Bmatrix} Y_1 \\ Y_2 \\ Y_3 \\ Y_4 \end{Bmatrix} = \begin{bmatrix} 1 & 0 & 0 & 0 \\ -d_{21} & -d_{24} & -d_{25} & -d_{26} \\ -d_{11} & -d_{14} & -d_{15} & -d_{16} \\ 0 & 1 & 0 & 0 \end{bmatrix} \begin{Bmatrix} Y_1 \\ Y_4 \\ w_1 \\ w_2 \end{Bmatrix}.$$



#### D. SYSTEM TRANSFER FUNCTIONS

The entire system transfer function synthesis can be concisely summarized in a chronological sequence of steps that began with linearization of the coupled mechanical/control law equations that govern the dynamical motion. This process included linearization of additional equations that contained specific variables required for further consideration in the stability analysis; namely, plant sensor signals and control system outputs. A similarity transformation has been introduced which in effect, exchanges original state variables for these desired sensor signals and controller outputs such that the resulting modified state vector still is representative of an independent set of state variables. The resulting system of state space equations is later identified as Equation III-28.

The system characteristic matrix,  $A_{ij}$ , provides the basis for evaluating the coupled mechanical/control system resonant characteristics (natural frequencies) as well as providing the fundamental basis for specification and determination of the various types of transfer functions. The next subsection addresses some of the more specific details regarding specific transfer function relationships. A particular transfer function is identified by a *type* along with the desired output/input variable designation. An eigenvalue problem is then stated, which leads to determination of the numerator roots (zeros) and denominator roots (poles) for the particular transfer function. Once the poles and zeros are known for a transfer function, this information can be further processed and displayed by any of the conventional display modes: Bode, Nichols, Nyquist, and/or root locus.

The conventional block diagram representation for the coupled plant/controller system (Figure III-2) provides additional insight for determination of system transfer functions.

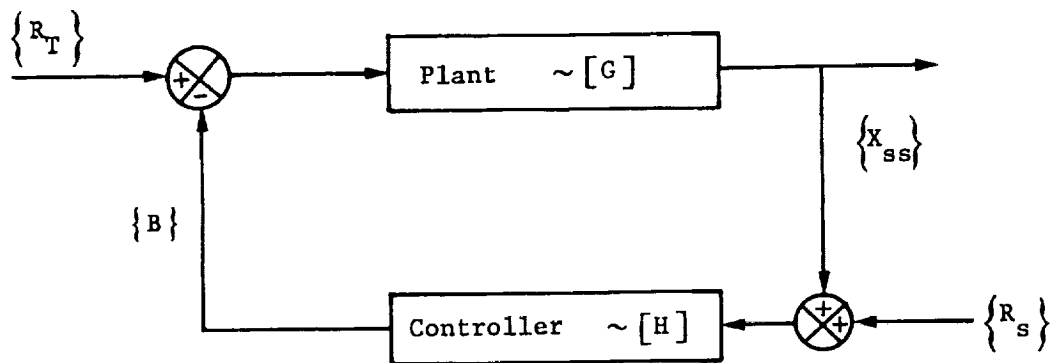

Figure III-2 Plant/Controller Block Diagram

The first-order differential equations for the system are written as

$$[\text{III-28}] \dot{Z}^i = A_{ij} Z^j + B_{Tij} R_T^j + B_{Sij} R_S^j$$

and it is helpful at this point to express the equation in matrix form and indicate the separate partitioned subsets of  $\dot{Z}^i$ ,  $A_{ij}$ ,  $Z^j$ ,  $B_{Tij}$ ,  $R_T^j$ ,  $B_{Sij}$  and  $R_S^j$  as

$$[\text{III-29}] \begin{Bmatrix} \dot{y} \\ \dot{x}_{ss} \\ \delta \\ \dot{B} \end{Bmatrix} = \begin{bmatrix} a_{11} & a_{12} & a_{13} & a_{14} \\ a_{21} & a_{22} & a_{23} & a_{24} \\ a_{31} & a_{32} & a_{33} & a_{34} \\ a_{41} & a_{42} & a_{43} & a_{44} \end{bmatrix} \begin{Bmatrix} y \\ x_{ss} \\ \delta \\ B \end{Bmatrix} + \begin{bmatrix} b_{T1} \\ b_{T2} \\ b_{T3} \\ b_{T4} \end{bmatrix} \{R_T\} + \begin{bmatrix} b_{S1} \\ b_{S2} \\ b_{S3} \\ b_{S4} \end{bmatrix} \{R_S\} .$$

The following observations are noted;

$$\begin{aligned} a_{31} &= 0 & b_{T1} &= -a_{14} & b_{S1} &= 0 \\ a_{41} &= 0 & b_{T2} &= -a_{24} & b_{S2} &= 0 \\ a_{13} &= 0 & b_{T3} &= 0 & b_{S3} &= a_{32} \\ a_{23} &= 0 & b_{T4} &= 0 & b_{S4} &= a_{42} \end{aligned}$$

and Equation III-29 can be restated as

$$[\text{III-30}] \begin{Bmatrix} \dot{y} \\ \dot{X}_{ss} \\ \dot{\delta} \\ \dot{B} \end{Bmatrix} = \begin{bmatrix} a_{11} & a_{12} & & a_{14} \\ a_{21} & a_{22} & & a_{24} \\ & a_{32} & a_{33} & a_{34} \\ & a_{42} & a_{43} & a_{44} \end{bmatrix} \begin{Bmatrix} y \\ X_{ss} \\ \delta \\ B \end{Bmatrix} + \begin{bmatrix} -a_{14} \\ -a_{24} \\ 0 \\ 0 \end{bmatrix} \{R_T\} + \begin{bmatrix} 0 \\ 0 \\ a_{32} \\ a_{42} \end{bmatrix} \{R_S\}.$$

Equations III-30 are the operating basis for stating particular transfer function relationships for the plant/controller system.

The general procedure is to establish a system transfer function between inputs  $R_T$  and  $R_S$  and outputs  $X_{ss}$  and  $B$ . Loops may be opened to provide open loop information by manipulation of the  $A_{ij}$  coefficients to prohibit certain feedbacks.

To symbolically describe specification of a transfer function we begin by consolidating the  $b$  coefficients and taking the Laplace transform of Equation III-30 to give

$$[\text{III-31}] [Is] \{Z(s)\} = [A] \{Z(s)\} + [b] \{U(s)\}$$

or

$$[\text{III-32}] \left[ [Is] - [A] \right] \{Z(s)\} = [b] \{U(s)\}$$

and then employ Cramer's Rule to evaluate a given element  $Z(s)^p$  due to a particular input  $U(s)^q$  where

$$[\text{III-33}] Z(s)^{p/U(s)^q} = \frac{\text{aug} \begin{vmatrix} Is - A \\ \phantom{Is - A} \end{vmatrix}}{\begin{vmatrix} Is - A \end{vmatrix}}$$

and where  $\text{aug} \begin{vmatrix} Is - A \\ \phantom{Is - A} \end{vmatrix}$  is accomplished by placing column  $q$  of  $b$  into column  $p$  of  $\begin{vmatrix} Is - A \end{vmatrix}$ .

The Q-R algorithm\* is a useful tool with which to extract the indicated determinants in Equation III-33.

---

\* J. G. F. Francis, "The QR-Transformation - A Unitary Analogue to the LR-Transformation." *The Computer Journal*, Volume 4, October 1961 (Part 1) and Volume 5, January 1962 (Part 2).

## 1. The Root Extraction Process

With reference to Equation III-33 it is desired to evaluate both the numerator and denominator roots. The denominator root extraction is straightforward in that we wish to find  $p_1, p_2, p_3, \dots, p_n$  from an expression of the form

$$D(s) = \det([I]s - [A])$$

such that

$$[\text{III-34}] D(s) = (s - p_1)(s - p_2) \cdots (s - p_n) = \prod_{i=1}^n (s - p_i).$$

This evaluation is completed by extracting the characteristic roots of the matrix  $A_{ij}$ . In general these roots will be complex because  $A_{ij}$  is not symmetric.

The process employed for evaluating the numerator is best illustrated with an example. Consider that we have the (4x4) characteristic system matrix,

$$[A_{ij}] = \begin{bmatrix} a_{11} & a_{12} & a_{13} & a_{14} \\ a_{21} & a_{22} & a_{23} & a_{24} \\ a_{31} & a_{32} & a_{33} & a_{34} \\ a_{41} & a_{42} & a_{43} & a_{44} \end{bmatrix}$$

and the column of coefficients  $b_i$  which premultiply the desired input variable  $U^q$ . Further, let it be desired to obtain the transfer function relating output of the third variable in the state equations  $y_3$  to the input  $U^q$ .

The state equations for this system would appear as

$$[\text{III-35}] \begin{Bmatrix} \dot{y}_1 \\ \dot{y}_2 \\ \dot{y}_3 \\ \dot{y}_4 \end{Bmatrix} = \begin{bmatrix} a_{11} & a_{12} & a_{13} & a_{14} \\ a_{21} & a_{22} & a_{23} & a_{24} \\ a_{31} & a_{32} & a_{33} & a_{34} \\ a_{41} & a_{42} & a_{43} & a_{44} \end{bmatrix} \begin{Bmatrix} y_1 \\ y_2 \\ y_3 \\ y_4 \end{Bmatrix} + \begin{Bmatrix} b_1 \\ b_2 \\ b_3 \\ b_4 \end{Bmatrix} U^q$$

and, with reference to Equation III-33, the numerator is

$$N(s) = \text{aug} |Is - A| \text{ or}$$

$$[\text{III-36}] N(s) = \det \begin{vmatrix} s - a_{11} & -a_{12} & b_1 & -a_{14} \\ -a_{21} & s - a_{22} & b_2 & -a_{24} \\ -a_{31} & -a_{32} & b_3 & -a_{34} \\ -a_{41} & -a_{42} & b_4 & s - a_{44} \end{vmatrix} .$$

After performing elementary row operations, Equation III-36 can be restated in the form

$$[\text{III-37}] N(s) = b_3 \det \begin{vmatrix} s - a_{11} + a_{31} b_1/b_3 & -a_{12} + a_{32} b_1/b_3 & -a_{14} + a_{34} b_1/b_3 \\ -a_{21} + a_{31} b_2/b_3 & s - a_{22} + a_{32} b_2/b_3 & -a_{24} + a_{34} b_2/b_3 \\ -a_{41} + a_{31} b_4/b_3 & -a_{42} + a_{32} b_4/b_3 & s - a_{44} + a_{34} b_4/b_3 \end{vmatrix}$$

or, in symbolic terms as

$$[\text{III-38}] N(s) = b_3 \det |[Is] - [\bar{a}]|$$

where the matrix  $\bar{a}$  is given as

$$\begin{bmatrix} a_{11} - a_{31} b_1/b_3 & a_{12} - a_{32} b_1/b_3 & a_{14} - a_{34} b_1/b_3 \\ a_{21} - a_{31} b_2/b_3 & a_{22} - a_{32} b_2/b_3 & a_{24} - a_{34} b_2/b_3 \\ a_{41} - a_{31} b_4/b_3 & a_{42} - a_{32} b_4/b_3 & a_{44} - a_{34} b_4/b_3 \end{bmatrix} .$$

Note that the previous expression for  $N(s)$  is finite only if  $b_3 \neq 0$  and the question is--can  $b_3$  realistically be null? The answer is *yes* as the following example indicates.

#### Example

Consider the simple mechanical system consisting of two masses connected by a single spring/dashpot combination as shown in the sketch.

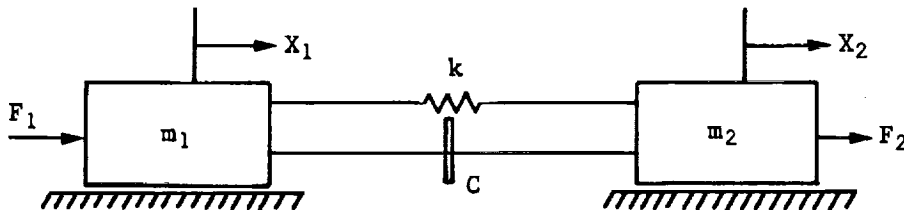

The state space representation is

$$\frac{d}{dt} \begin{Bmatrix} \dot{X}_1 \\ \dot{X}_2 \\ X_1 \\ X_2 \end{Bmatrix} = \begin{bmatrix} -c/m_1 & c/m_1 & -k/m_1 & k/m_1 \\ c/m_2 & -c/m_2 & k/m_2 & -k/m_2 \\ 1 & & & \\ & 1 & & \end{bmatrix} \begin{Bmatrix} \dot{X}_1 \\ \dot{X}_2 \\ X_1 \\ X_2 \end{Bmatrix} + \begin{bmatrix} 1/m_1 & 0 \\ 0 & 1/m_2 \\ 0 & 0 \\ 0 & 0 \end{bmatrix} \begin{Bmatrix} F_1 \\ F_2 \end{Bmatrix}$$

and the frequency domain (or transformed) equations in  $s$  are

$$\left[ [I]s - [A] \right] \begin{Bmatrix} \dot{X}_1(s) \\ \dot{X}_2(s) \\ X_1(s) \\ X_2(s) \end{Bmatrix} = \begin{bmatrix} 1/m_1 & 0 \\ 0 & 1/m_2 \\ 0 & 0 \\ 0 & 0 \end{bmatrix} \begin{Bmatrix} F_1 \\ F_2 \end{Bmatrix}$$

where

$$[A] = \begin{bmatrix} -c/m_1 & c/m_1 & -k/m_1 & k/m_1 \\ c/m_2 & -c/m_2 & k/m_2 & -k/m_2 \\ 1 & 0 & 0 & 0 \\ 0 & 1 & 0 & 0 \end{bmatrix}$$

Consider now the transfer function  $\dot{X}_1(s)/F_1$  where the augmented numerator is

$$N(s) = \det \begin{vmatrix} 1/m_1 & -c/m_1 & k/m_1 & -k/m_1 \\ 0 & s + c/m_2 & -k/m_2 & k/m_2 \\ 0 & 0 & s & 0 \\ 0 & -1 & 0 & s \end{vmatrix}$$

and the pivot element is the (1, 1) element or  $1/m_1 \neq 0$ . On the other hand, the transfer function  $X_1(s)/F_1$  has the augmented numerator

$$N(s) = \det \begin{vmatrix} s + c/m_1 & -c/m_1 & 1/m_1 & -k/m_1 \\ -c/m_2 & s + c/m_2 & 0 & k/m_2 \\ -1 & 0 & 0 & 0 \\ 0 & -1 & 0 & s \end{vmatrix}$$

and the pivot element is the (3, 3) element, which is null.

The problem we now address involves evaluation of the numerator determinant  $N(s)$  when the pivotal element is null. The particular mathematical problem may be restated as

$$[\text{III-39}] \quad N(s) = \det \left| \begin{bmatrix} \tilde{I} \end{bmatrix} s - \begin{bmatrix} \tilde{A} \end{bmatrix} \right|$$

where

$\begin{bmatrix} \tilde{I} \end{bmatrix}$  is the identity matrix  $\begin{bmatrix} I \end{bmatrix}$  of size  $N$  with a null diagonal element.

Addition and subtraction of the quantity  $\begin{bmatrix} \tilde{I} \end{bmatrix} \chi$  (where  $\chi$  is an arbitrary constant not equal to one of the roots of  $\begin{bmatrix} \tilde{A} \end{bmatrix}$ ) yields

$$[\text{III-40}] \quad N(s) = \det \left| \begin{bmatrix} \tilde{I} \end{bmatrix} (s - \chi) - \left[ \begin{bmatrix} \tilde{A} \end{bmatrix} - \begin{bmatrix} \tilde{I} \end{bmatrix} \chi \right] \right|$$

and if we define  $(s - \chi) \equiv 1/p$ , there results

$$[\text{III-41}] \quad N(s) = \frac{(-1)^N}{p^N} \det \left| \tilde{A} - \tilde{I}\chi \right| \left( \det \left| I p - (\tilde{A} - \tilde{I}\chi)^{-1} \tilde{I} \right| \right).$$

The roots,  $(p_i, i=1, N)$  are found as the eigenvalues of the expression

$$[\text{III-42}] \quad \left[ \begin{bmatrix} \tilde{A} \end{bmatrix} - \begin{bmatrix} \tilde{I} \end{bmatrix} \chi \right]^{-1} \begin{bmatrix} \tilde{I} \end{bmatrix}$$

and the eigensolution permits  $N(s)$  to be written as

$$[\text{III-43}] \quad N(s) = \frac{(-1)^N}{p^N} \det \left| \tilde{A} - \tilde{I}\chi \right| \left\{ (p - p_1) (p - p_2) \cdots (p - p_N) \right\}.$$

We now make the following observation: a  $p_i$  equal to zero implies a root at infinity (or a characteristic polynomial having order less than  $N$ ). Thus, the null  $p_i$ 's are eliminated from the expression giving the characteristic polynomial an order  $n$ , which is less than  $N$ . It is a rather common occurrence for the number of zeros (order of  $N(s)$ ) to be significantly less than the number of poles (order of  $D(s)$ ). With reference to Equation III-43, the numerator expression,  $N(s)$  can be written as

$$[\text{III-44}] \quad N(s) = (-1)^N \det \left| \tilde{A} - \tilde{I}\chi \right| \left\{ \left(1 - \frac{p_1}{p}\right) \left(1 - \frac{p_2}{p}\right) \cdots \left(1 - \frac{p_n}{p}\right) \right\}$$

and, recalling that  $p = \frac{1}{s-\chi}$ , yields

$$[\text{III-45}] \quad N(s) = \frac{(-1)^N}{\prod_{i=1}^n (\chi - s_i)} \det \left| \tilde{A} - \tilde{I}\chi \right| \left\{ (s - s_1) (s - s_2) \cdots (s - s_n) \right\}.$$

Next, we note that

$$[\text{III-46}] \quad \prod_{i=1}^n (\chi - s_i) = \prod_{i=1}^n \left( \frac{-1}{p_i} \right)$$

and it follows that

$$[\text{III-47}] \quad N(s) = (-1)^{N-n} \prod_{i=1}^n p_i \det \left| \tilde{A} - \tilde{I}\chi \right| \prod_{i=1}^n (s - s_i).$$

The numerator root gain,  $k_R$ , can now be identified as

$$[\text{III-48}] \quad k_R = (-1)^{N-n} \prod_{i=1}^n p_i \det \left| \tilde{A} - \tilde{I}\chi \right|$$

and the Bode gain,  $k_B$ , for the numerator is

$$k_B = k_R (-1)^m \prod_{i=1}^m s_i \quad \text{where } m \leq n.$$

## 2. Transfer Function Classification

With reference to Figure III-2 it is possible to directly identify six transfer function types. Each type is characterized by the specific variables involved and by the presence of feedback. Additionally, a seventh type will also be described whereby certain of the control variables feed back and others do not. This type is similar to an open loop transfer function but treats selected channels of the controller as part of the mechanical system (plant). During the course of this discussion it will become apparent that additional transfer function types are easily accommodated by rather simple manipulations with the system characteristic matrix,  $A_{ij}$ .



In general it should be noted that the process of obtaining the desired transfer function involves but a few basic steps. The transfer function characteristic matrix,  $\mathbb{R}_{ij}$ , and the desired force coefficient vector,  $b_i$  are obtained directly from the system characteristic matrix  $A_{ij}$ . These two matrices are then put in a form such that the Q-R algorithm can be employed to extract system roots.

#### Type I (Plant Only)

Type I is the forward path transfer function for the plant with no feedback and is of the form

$$[\text{III-49}] \quad X_{ss}^P / R_T^q = G(s).$$

The control variables  $\delta^i$  and control outputs,  $B^i$ , do not feed back into the plant. The matrix expression depicting the system of interest is

$$[\text{III-50}] \quad \frac{d}{dt} \begin{Bmatrix} y \\ X_{ss} \end{Bmatrix} = \begin{bmatrix} a_{11} & a_{12} \\ a_{21} & a_{22} \end{bmatrix} \begin{Bmatrix} y \\ X_{ss} \end{Bmatrix} + \begin{bmatrix} b_{T1} \\ b_{T2} \end{bmatrix} \{R_T\}.$$

The matrix,  $A_{ij}$ , to use in the general expression given as Equation III-33 is referred to as  $\mathbb{R}_{ij}$  or the reduced  $A_{ij}$  matrix,

$$[\text{III-51}] \quad \mathbb{R}_{ij} = \begin{bmatrix} a_{11} & a_{12} \\ a_{21} & a_{22} \end{bmatrix}.$$

The augmented  $\mathbb{R}_{ij}$  matrix is obtained by removing the column corresponding to the input variable,  $R_T^q$ , from the expression  $b_T$  and inserting this column into the column in  $\mathbb{R}_{ij}$ , which corresponds to the desired output,  $X_{ss}^P$ . The resulting transfer function is then given as

$$[\text{III-52}] \quad X_{ss}^P / R_T^q = \frac{\text{aug } |Is - \mathbb{R}|}{|Is - \mathbb{R}|}.$$

Type II (Controller Only)

Type II represents the feedback path,  $H(s)$ , for the controller only. The desired transfer function relates control system outputs  $B^i$  to sensor signal inputs,  $X_{SS}^j$ ,

[III-53]  $B^P/X_{SS}^q = H(s)$ .

The reduced characteristic matrix  $R_{ij}$  and the corresponding input coefficients,  $b_{ik}$ , are given as

[III-54]  $R_{ij} = \begin{bmatrix} a_{33} & a_{34} \\ a_{43} & a_{44} \end{bmatrix}$ ,  $b_{ik} = \begin{bmatrix} a_{32} \\ a_{42} \end{bmatrix}$ .

Type III (Open Loop, GH)

Type III falls within the framework of the classical open-loop transfer function designation and relates control system outputs  $B^i$  to external plant inputs  $R_T^j$ . The algebraic expression for a given output variable,  $B^P$ , due to an external input,  $R_T^q$ , is indicated as

[III-55]  $B^P/R_T^q = (GH)(s)$ .

The open-loop system characteristic matrix  $R_{ij}$  and corresponding input coefficients,  $b_{ik}$ , are

[III-56]  $R_{ij} = \begin{bmatrix} a_{11} & a_{12} & & \\ a_{21} & a_{22} & & \\ & a_{32} & a_{33} & a_{43} \\ & a_{42} & a_{43} & a_{44} \end{bmatrix}$ ,  $b_{ik} = \begin{bmatrix} -a_{14} \\ -a_{24} \\ 0 \\ 0 \end{bmatrix}$ .

Previously it was noted that  $a_{31} = a_{41} = a_{13} = a_{23} = 0$  and, in addition, the partitions  $a_{14}$  and  $a_{24}$  are set to zero to prohibit the  $B^i$  feedback. Thus, the loop is opened to establish GH, the open-loop transfer function in  $s$ . Note that the negative sign in the  $b_{ik}$  coefficients simply indicates that the  $B^i$  feedback is negative with respect to the external plant inputs,  $R_T^j$ .

Type IV (Open Loop, HG)

An additional open-loop transfer function is often desired to assess the plant sensor signal outputs due to controller noise inputs. The transfer function then relates sensor signal outputs,  $X_{ss}^i$ , to control system noise inputs,  $R_s^j$ . The plant sensor signal vector does not feed back into the system so that we have

$$[III-57] X_{ss}^P/R_s^Q = (HG)_{(s)}$$

and the system characteristic matrix,  $R_{ij}$ , and the external input coefficients,  $b_{ik}$ , are identified as

$$[III-58] R_{ij} = \begin{bmatrix} a_{11} & a_{12} & & a_{14} \\ a_{21} & a_{22} & & a_{24} \\ & & a_{33} & a_{34} \\ & & a_{43} & a_{44} \end{bmatrix}, b_{ik} = \begin{bmatrix} 0 \\ 0 \\ a_{32} \\ a_{42} \end{bmatrix}.$$

Note that the  $a_{32}$  and  $a_{42}$  partitions have been nulled to eliminate sensor signal feedback.

Type V (Closed Loop - Control Ratio)

The system control ratio is given as the transfer function that relates plant variable outputs to externally applied plant inputs with the control system entirely active. We express this transfer function as

$$[III-59] X_{ss}^P/R_T^Q = \left( \frac{G}{1+GH} \right)_{(s)}.$$

and the system characteristic matrix  $R_{ij}$  and the external input coefficients  $b_{ik}$  are identified as

$$[III-60] R_{ij} = \begin{bmatrix} a_{11} & a_{12} & & a_{14} \\ a_{21} & a_{22} & & a_{24} \\ & a_{32} & a_{33} & a_{34} \\ & a_{42} & a_{43} & a_{44} \end{bmatrix}; b_{ik} = \begin{bmatrix} -a_{14} \\ -a_{24} \\ 0 \\ 0 \end{bmatrix}.$$

The negative sign in the matrix  $b_{ik}$  indicates that the feedback is negative.

Type VI (Closed Loop)

An additional closed-loop transfer function has been accommodated within the digital simulation. Specifically, Type VI relates plant sensor signal outputs to sensor signal noise inputs with all control system loops active. The transfer function is symbolically indicated as:

$$[III-61] X_{ss}^P = (\text{transfer function}) R_s^Q$$

where the system characteristic matrix,  $R_{ij}$ , and corresponding input coefficients are identified as

$$[III-62] R_{ij} = \begin{bmatrix} a_{11} & a_{12} & a_{14} \\ a_{21} & a_{22} & a_{24} \\ & a_{32} & a_{33} & a_{34} \\ & a_{42} & a_{43} & a_{44} \end{bmatrix}, b_{ik} = \begin{bmatrix} 0 \\ 0 \\ a_{32} \\ a_{42} \end{bmatrix}.$$

Type VII (Quasi-Open Loop)

An additional transfer function type is identified here and referred to as quasi-open loop. It is of the open loop type in that we are interested in control system outputs,  $B^i$ , due to plant variable inputs,  $R_T^j$ . For example, suppose that for a multi-channel control system (such as azimuth and elevation), we desire outputs  $B^i$  on the controller channel that do not feed back and that the other channel is active in that it feeds back into the plant.

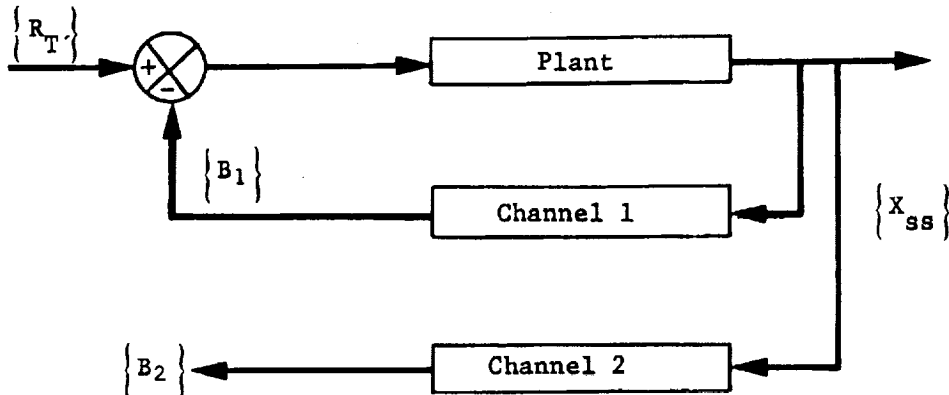

For the configuration indicated, a typical Type VII transfer function (TF) would be given by

$$B_2^P = (\text{transfer function}) R_T^Q$$

and the form of the system characteristic matrix,  $\mathbb{R}_{ij}$ , and plant input coefficient matrix  $b_{ik}$  would be

[III-63] 
$$\mathbb{R}_{ij} = \begin{bmatrix} a_{11} & a_{12} & & \tilde{a}_{14} \\ a_{21} & a_{22} & & \tilde{a}_{24} \\ & a_{32} & a_{33} & a_{34} \\ & a_{42} & a_{43} & a_{44} \end{bmatrix}, \quad b_{ik} = \begin{bmatrix} -a_{14} \\ -a_{24} \\ 0 \\ 0 \end{bmatrix}.$$

The subpartitions  $\tilde{a}_{14}$  and  $\tilde{a}_{24}$  indicate modification of the original partitions  $a_{14}$  and  $a_{24}$ . Specifically,  $\tilde{a}_{mn}$  is a subset of  $a_{ij}$  obtained by keeping only those  $n$  columns of  $a_{mn}$  that correspond to the  $B^i$  variables that feed back to the plant.

### 3. Transfer Functions - Polynomial Description

This subsection is addressed to implementation of control system transfer functions described as the ratio of two polynomials in the frequency domain,  $s$ . Specifically, we consider

[III-64] 
$$TF = P(s)/Q(s)$$

where

$$Q(s) = a_0 + a_1s + a_2s^2 + a_3s^3 + \dots + a_ns^n$$

and

$$P(s) = b_0 + b_1s + b_2s^2 + \dots + b_ms^m.$$

Because the previously described governing equations have been stated in canonical first-order form, we propose to restate the polynomial description for the transfer function in the form

[III-65] 
$$\dot{\delta}^i = A_{ij} \delta^j + B_i U$$

The block diagram for the system is

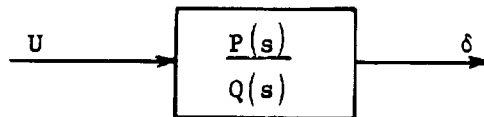

[III-66] from which we write

$$\delta = \frac{P(s)}{Q(s)} U$$

and expansion of the implied operator in  $s$  results in a differential equation of the form

$$[\text{III-67}] \quad a_n \delta^n + a_{n-1} \delta^{n-1} + \dots + a_1 \dot{\delta} + a_0 \delta = b_m U^m + b_{m-1} U^{m-1} + \dots + b_1 \dot{U} + b_0 U$$

$$\text{where } \delta^n = \frac{d^n \delta}{dt^n}.$$

In general, the order of  $P(s)$  will be no greater than the order of  $Q(s)$  or  $m \leq n$ .

a.  $m=n$

We divide Equation III-67 by  $a_n$  to obtain

$$[\text{III-63}] \quad \delta^n + C_{n-1} \delta^{n-1} + \dots + C_1 \dot{\delta} + C_0 \delta = d_m U^m + d_{m-1} U^{m-1} + \dots + d_1 \dot{U} + d_0 U$$

$$\text{where } C_i = \frac{a_i}{a_n} \text{ and } d_i = \frac{b_i}{a_n}$$

An example will be used for illustration.

*Example:* Consider the equation with  $m=n=4$ ,

$$\delta^4 + C_3 \delta^3 + C_2 \delta^2 + C_1 \dot{\delta} + C_0 \delta = d_4 \ddot{\ddot{U}} + d_3 \dot{\ddot{U}} + d_2 \dot{\dot{U}} + d_1 \dot{U} + d_0 U$$

or, in operator form

$$s^4 \delta + s^3 C_3 \delta + s^2 C_2 \delta + C_1 s \delta + C_0 \delta = s^4 d_4 U + s^3 d_3 U + s^2 d_2 U + s d_1 U + d_0 U.$$

This can be rewritten as

$$s^4 (\delta - d_4 U) + s^3 (C_3 \delta - d_3 U) + s^2 (C_2 \delta - d_2 U) + s (C_1 \delta - d_1 U) + (C_0 \delta - d_0 U) = 0.$$

and the substitution

$$\delta_1 = \delta - d_4 U$$

permits a reduction in order to

$$s^3 (\delta_1 + C_3 \delta - d_3 U) + s^2 (C_2 \delta - d_2 U) + s (C_1 \delta - d_1 U) + (C_0 \delta - d_0 U) = 0.$$

we can again introduce a new variable

$$\delta_2 = (\delta_1 + C_3 \delta - d_3 U)$$

and rewrite the previous as

$$s^2(\dot{\delta}_2 + C_2\delta - d_2U) + s(C_1\delta - d_1U) + (C_0\delta - d_0U) = 0.$$

It follows that if we define

$$\delta_3 = \dot{\delta}_2 + C_2\delta - d_2U$$

there results

$$s(\dot{\delta}_3 + C_1\delta - d_1U) + C_0\delta - d_0U = 0,$$

and the substitution

$$\delta_4 = \dot{\delta}_3 + C_1\delta - d_1U$$

gives

$$\dot{\delta}_4 = -C_0\delta + d_0U.$$

The variable  $\delta$  can now be eliminated from each of the above expressions and the results generalized to  $n^{th}$  order systems.

The result is concisely stated as a matrix equation that is recognized to be of the desired form initially given as Equation III-65,

$$[III-69] \begin{Bmatrix} \dot{\delta}_1 \\ \dot{\delta}_2 \\ \vdots \\ \dot{\delta}_{n-1} \\ \dot{\delta}_n \end{Bmatrix} = \begin{bmatrix} -C_{n-1} & 1 & 0 & \cdot & \cdot & 0 \\ -C_{n-2} & 0 & 1 & \cdot & \cdot & 0 \\ \cdot & \cdot & \cdot & \cdot & \cdot & \cdot \\ \cdot & \cdot & \cdot & \cdot & \cdot & \cdot \\ -C_1 & 0 & 0 & \cdot & \cdot & 1 \\ -C_0 & 0 & 0 & \cdot & \cdot & 0 \end{bmatrix} \begin{Bmatrix} \delta_1 \\ \delta_2 \\ \vdots \\ \delta_{n-1} \\ \delta_n \end{Bmatrix} + \begin{Bmatrix} d_{n-1} - C_{n-1}d_n \\ d_{n-2} - C_{n-2}d_n \\ \vdots \\ d_1 - C_1d_n \\ d_0 - C_0d_n \end{Bmatrix} U$$

where  $\delta_1$  and  $\delta$ , the original variable of the equation, are related as shown previously and  $U$  is the input variable to the transfer function expression as indicated in Equation III-65.

b.  $m < n$

The general expression for the case where  $m < n$  is easily accommodated by restricting the  $d_i$  coefficients to reflect the limit  $m$ .

Commonly, only the  $d_0$  coefficient will be finite.

#### 4. Frequency Response

Transfer function poles, zeros, and root gain can be converted to the standard Bode form for frequency response by combining time constants, damping, and resonant frequencies as

$$[III-70] \text{ TF} = k_B \frac{s^r \prod_{i=1}^{N1} (1 + \tau_i s) \prod_{i=1}^{N2} \left( 1 + \frac{2\zeta_i s}{\omega_i} + \frac{s^2}{\omega_i^2} \right)}{\prod_{j=1}^{M1} (1 + \tau_j s) \prod_{j=1}^{M2} \left( 1 + \frac{2\zeta_j s}{\omega_j} + \frac{s^2}{\omega_j^2} \right)}$$

where the Bode gain is

$$k_B = k \frac{\prod_{i=1}^n z_i}{\prod_{j=1}^m p_j} \quad \text{where } k = \text{root gain and}$$

$\tau$  = system constants

$\zeta$  = system damping at frequency  $\omega$

$\omega$  = system resonant frequency.

The frequency response is then calculated by substituting  $j\omega$  for  $s$  and evaluating the transfer function expression at various  $\omega$ 's. The digital simulation uses a vernier frequency incrementing approach that automatically introduces smaller frequency increments near the poles and zeros. This variable frequency incrementing technique permits better transfer function resolution near the resonances where amplitude and phase can vary rapidly.

#### 5. Root Locus

The root locus method of analysis and design is based on the relationship between the poles and zeros of the closed loop transfer function and those of the open loop transfer function. The method is used to determine the location of the roots of the characteristic equation as a function of a single open loop gain parameter. The locations of these roots are indicative of the relative system stability. The analyst may use the method as a design tool by adjusting the poles and zeros and the open-loop gain parameters in such a way as to yield a closed loop system with satisfactory critical frequencies (poles and zeros).



To further describe the theoretical basis for the method we refer to the conventional control ratio for a feedback system as shown in Figure III-3.

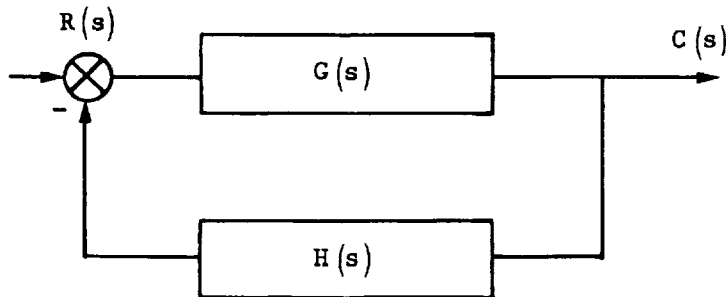

Figure III-3 Conventional Feedback Control System

The control ratio  $C(s)/R(s)$  is

$$[\text{III-71}] \frac{C(s)}{R(s)} = \frac{G(s)}{1 + G(s) H(s)}$$

and the open loop transfer function  $G(s) H(s)$  is identified as a ratio of two functions in  $s$ ,

$$[\text{III-72}] G(s) H(s) = k \frac{P(s)}{Q(s)}$$

The characteristic system equation is

$$[\text{III-73}] 1 + G(s) H(s) = 0$$

$$\text{or} \\ 1 + k \frac{P(s)}{Q(s)} = 0.$$

The conventional root locus plot portrays the loci of the values of  $s$  that satisfy the characteristic equation as  $k$  varies from zero to infinity and we note

- 1) at  $k=0$ , the roots of the characteristic equation are equal to the roots of  $Q(s)$ , which are the same as the poles of the open loop transfer function,  $k \frac{P(s)}{Q(s)}$ ;

2) as  $k$  approaches infinity, the roots approach the roots of  $P(s)$ , the open loop zeros.

Thus, as  $k$  varies from 0 to infinity, the loci of the closed loop poles migrate from the open loop poles to the open loop zeros and the direction of migration depends on the sign of the open loop gain parameter,  $k$ .

Rewriting Equation III-73 yields a more conventional expression for the characteristic equation as

$$\text{[III-74]} \quad k \frac{P(s)}{Q(s)} = -1$$

and two conditions are required;

$$1) \quad \left| k \frac{P(s)}{Q(s)} \right| = 1;$$

$$2) \quad \angle P(s)/Q(s) = 130^\circ, \quad k \geq 0 \quad .$$

The first of these conditions can be expressed as

$$k = \left| \frac{Q(s)}{P(s)} \right|$$

for those values of  $s$  that satisfy the angle criterion. The conditions that govern the migration of the roots in the complex plane can be solved by an iterative procedure. The iterative procedure for evaluation of a single root locus\* is described in Appendix E.

#### E. LINEAR TIME DOMAIN RESPONSE

The linearized canonical first-order system of equations can also provide a basis for studying system time history in terms of perturbations about a specified state when the system indeed behaves

---

\* Welch, Raymond V. National Aeronautics and Space Administration  
Goddard Space Flight Center, Branch Report No. 254, October 2,  
1973.

in a linear manner in the vicinity of the state. The nonhomogeneous form of the equations was the basis for determination of system transfer functions and appeared previously as

$$[\text{III-75}] \dot{z}^i = A_{ij} z^j + b_{ik} U^k(t).$$

The external system inputs are the elements of  $U^k$ . It is convenient to establish the solution for the above system through use of a recursive formula numerical integration procedure rather than through the Runge-Kutta approach.

Consider the Adams' corrector formula\* at time  $t+1$ ,

$$[\text{III-76}] \eta_{t+1} = \eta_t + \frac{h}{24} \left[ 9 \dot{\eta}_{t+1} + 19 \dot{\eta}_t - 5 \dot{\eta}_{t-1} + \dot{\eta}_{t-2} \right]$$

where  $h$  is the incremented time step.

Application of this formula to our system of equations gives

$$z_{t+1}^i = z_t^i + \frac{h}{24} \left[ 9 A_{ij} z_{t+1}^j + 9 b_{ik} U_{t+1}^k + 19 \dot{z}_t^i - 5 \dot{z}_{t-1}^i + \dot{z}_{t-2}^i \right]$$

and manipulation yields the solution for all the  $z^i$  at time step,  $t+1$

$$\begin{Bmatrix} z \\ \dot{z} \end{Bmatrix}_{t+1} = \left[ \begin{bmatrix} I \\ -\frac{3h}{8} [A] \end{bmatrix} \right]^{-1} \left\{ \begin{Bmatrix} z \\ \dot{z} \end{Bmatrix}_t + \frac{h}{24} \left( 9 \begin{bmatrix} b \\ U \end{bmatrix}_{t+1} + 19 \begin{Bmatrix} \dot{z} \\ \dot{z} \end{Bmatrix}_t - 5 \begin{Bmatrix} \dot{z} \\ \dot{z} \end{Bmatrix}_{t-1} + \begin{Bmatrix} \dot{z} \\ \dot{z} \end{Bmatrix}_{t-2} \right) \right\}.$$

Note the requirement for  $\dot{z}^i$  at time step  $t-2$ ; hence, the requirement for a starter (e.g., Runge-Kutta) to initiate the solution process.

---

\*F. Schied. "Theory and Problems of Numerical Analysis," *Schaum's Outline Series*, McGraw-Hill Book Company, New York 1968.

APPENDIX A--DEVELOPMENT OF THE INERTIAL INTEGRALS

---

In the development of the equations of motion (Refer to Chapter II, Sections B and D.) there are certain inertial integrals identified that are required to account for the deformation-dependent inertia matrix and that are involved in calculating the effects of centrifugal and Coriolis forces.

The basis for calculating these integrals is a triple matrix product involving a so-called discrete mass matrix  $[M]$ , which is assembled by use of finite element techniques, and which may be used in calculation of vibration modes. The other constituent of the triple matrix product is a modal transformation that transforms ordinary velocities, associated with the finite element model, to the velocities of the  $\{U\}_j$  vector.

Let us refer to the transformation as  $[\phi]$ , thus the triple matrix product is

$$[A-1] \quad [m] = [\phi]^T [M] [\phi],$$

which is the basis of the kinetic energy expression of Equation II-21. Now, the mass matrix  $[M]$  is invariable with respect to the body's deformation. The modal transformation  $[\phi]$  does, however, depend on the  $\{\xi\}$  in a linear fashion, or we may expand  $[\phi]$  as

$$[A-2] \quad [\phi] = [\phi]_0 + [\Delta\phi],$$

with  $[\phi]_0$  a matrix of constant elements and  $[\Delta\phi]$  variable with respect to deformation.

On substituting Equation A-2 into Equation A-1 and referring to Equation II-86 it follows that

$$[A-3] \quad [m_0] = [\phi_0]^T [M] [\phi_0],$$

$$[A-4] \quad [m_1]_j \xi_j = [\Delta\phi]^T [M] [\phi_0] + [\phi_0]^T [M] [\Delta\phi],$$

and

$$[A-5] \quad [m_2]_{jk} \xi_j \xi_k = [\Delta\phi]^T [M] [\Delta\phi].$$

Assume that the finite element model of the body has a "global" cartesian frame in which the ordinary velocities are measured, and further assume that the generalized coordinates of the finite element model are grouped (or ordered) such that all the x-translations are together, followed by all the y- then z- translations, and that the translations are followed by sets of x, y, and z rotations. With this implied ordering, it follows that the discrete mass matrix is partitioned in the form:

$$[A-6] \quad [M] = \begin{bmatrix} m_{xx} & m_{xy} & m_{xz} & m_{xp} & m_{xq} & m_{xr} \\ & m_{yy} & m_{yz} & m_{yp} & m_{yq} & m_{yr} \\ & & m_{zz} & m_{zp} & m_{zq} & m_{zr} \\ & & & m_{pp} & m_{pq} & m_{pr} \\ & & & & m_{qq} & m_{qr} \\ & & & & & m_{rr} \end{bmatrix}$$

(SYMMETRIC)

with p, q, and r corresponding to rotation coordinates about x, y, and z axes, respectively. Similarly, the modal transformation is partitioned as

$$[A-7] \quad [\phi] = \begin{bmatrix} & \{z+\eta_z\} & \{-y+\eta_y\} & \{1\} & & & [h_x] \\ \{z+\eta_z\} & & \{x+\eta_x\} & & \{1\} & & [h_y] \\ \{y+\eta_y\} & \{-x+\eta_x\} & & & & \{1\} & [h_z] \\ \{1\} & & & & & & [\sigma_x] \\ & \{1\} & & & & & [\sigma_y] \\ & & \{1\} & & & & [\sigma_z] \end{bmatrix}$$

Each square subpartition of Equation A-6 has rows equal to the number of structural joints (collocation points) of the finite element model, as does each subpartition of Equation A-7. The submatrices in the last column partition of Equation A-7, ( $[h_x]$ ,  $[h_y]$ ,  $\dots$ ,  $[\sigma_z]$ ), have columns equal to the number of deformation modes used to represent the body and are matrices of modal translation and rotation amplitudes.

The form of  $[\phi_0]$  and of  $[\Delta\phi]$  is seen immediately from Equation A-7 in that the only nonzero parts of  $[\Delta\phi]$  are due to the  $\{n\}$  vectors. The  $[\phi]$  matrix is effectively a kinematic velocity transformation consistent with the form of Equation II-25, and it follows that

$$\begin{aligned}
 \{\eta_x\} &= [h_x]\{\xi\}, \\
 \{\eta_y\} &= [h_y]\{\xi\}, \\
 \text{and } \{\eta_z\} &= [h_z]\{\xi\}.
 \end{aligned}
 \tag{A-8}$$

In the Equation A-4, there is seen the product of two constant matrices; namely  $[M][\phi_0]$ . The two triple products on the right of Equation A-4 require evaluation of only the first three row partitions of  $[M][\phi_0]$ . Thus let us define

(The first 3 row partitions of  $[M][\phi_0]$ ) =

$$\begin{array}{c}
 \left[ \begin{array}{cccccc|c}
 \{P_{x1}\} & \{P_{x2}\} & \{P_{x3}\} & \{P_{x4}\} & \{P_{x5}\} & \{P_{x6}\} & [P_{xk}] \\
 \{P_{y1}\} & \{P_{y2}\} & \{P_{y3}\} & \{P_{y4}\} & \{P_{y5}\} & \{P_{y6}\} & [P_{yk}] \\
 \{P_{z1}\} & \{P_{z2}\} & \{P_{z3}\} & \{P_{z4}\} & \{P_{z5}\} & \{P_{z6}\} & [P_{zk}]
 \end{array} \right]
 \end{array}
 \tag{A-9}$$

with, for example,

$$\{P_{x1}\} = [m_{xp}] \{1\} + [m_{xz}] \{y\} - [m_{xy}] \{z\}
 \tag{A-10}$$

and

$$\begin{aligned}
 [P_{xk}] &= [m_{xx}][h_x] + [m_{xy}][h_y] + [m_{xz}][h_z] \\
 &+ [m_{xp}][\sigma_x] + [m_{xq}][\sigma_y] + [m_{xr}][\sigma_z].
 \end{aligned}
 \tag{A-11}$$

It is unnecessary to expand each partition of Equation A-9; the partial product is numerically obtained and the examples of Equations A-10 and A-11 are just for purposes of illustration.

Now with reference to the intermediate constant matrices given by Equation A-9 and the definitions of Equations A-4 and A-5, the following inertial integrals are developed (the reader is urged to refer back to Chapter II, Section D, particularly Equations II-88 and II-89):

$$[A-12] \quad \begin{bmatrix} \alpha_1 \end{bmatrix} = \begin{bmatrix} P_{z4} \end{bmatrix} \begin{bmatrix} h_y \end{bmatrix} - \begin{bmatrix} P_{y4} \end{bmatrix} \begin{bmatrix} h_z \end{bmatrix}$$

$$[A-13] \quad \begin{bmatrix} \alpha_2 \end{bmatrix} = \begin{bmatrix} P_{z5} \end{bmatrix} \begin{bmatrix} h_y \end{bmatrix} - \begin{bmatrix} P_{y5} \end{bmatrix} \begin{bmatrix} h_z \end{bmatrix}$$

$$[A-14] \quad \begin{bmatrix} \alpha_3 \end{bmatrix} = \begin{bmatrix} P_{z6} \end{bmatrix} \begin{bmatrix} h_y \end{bmatrix} - \begin{bmatrix} P_{y6} \end{bmatrix} \begin{bmatrix} h_z \end{bmatrix}$$

$$[A-15] \quad \begin{bmatrix} \alpha_4 \end{bmatrix} = \begin{bmatrix} P_{x4} \end{bmatrix} \begin{bmatrix} h_z \end{bmatrix} - \begin{bmatrix} P_{z4} \end{bmatrix} \begin{bmatrix} h_x \end{bmatrix}$$

$$[A-16] \quad \begin{bmatrix} \alpha_5 \end{bmatrix} = \begin{bmatrix} P_{x5} \end{bmatrix} \begin{bmatrix} h_z \end{bmatrix} - \begin{bmatrix} P_{z5} \end{bmatrix} \begin{bmatrix} h_x \end{bmatrix}$$

$$[A-17] \quad \begin{bmatrix} \alpha_6 \end{bmatrix} = \begin{bmatrix} P_{x6} \end{bmatrix} \begin{bmatrix} h_z \end{bmatrix} - \begin{bmatrix} P_{z6} \end{bmatrix} \begin{bmatrix} h_x \end{bmatrix}$$

$$[A-18] \quad \begin{bmatrix} \alpha_7 \end{bmatrix} = \begin{bmatrix} P_{y4} \end{bmatrix} \begin{bmatrix} h_x \end{bmatrix} - \begin{bmatrix} P_{x4} \end{bmatrix} \begin{bmatrix} h_y \end{bmatrix}$$

$$[A-19] \quad \begin{bmatrix} \alpha_8 \end{bmatrix} = \begin{bmatrix} P_{y5} \end{bmatrix} \begin{bmatrix} h_x \end{bmatrix} - \begin{bmatrix} P_{x5} \end{bmatrix} \begin{bmatrix} h_y \end{bmatrix}$$

$$[A-20] \quad \begin{bmatrix} \alpha_9 \end{bmatrix} = \begin{bmatrix} P_{y6} \end{bmatrix} \begin{bmatrix} h_x \end{bmatrix} - \begin{bmatrix} P_{x6} \end{bmatrix} \begin{bmatrix} h_y \end{bmatrix}$$

$$[A-21] \quad \begin{bmatrix} b_1 \end{bmatrix} = \begin{bmatrix} P_{z1} \end{bmatrix} \begin{bmatrix} h_y \end{bmatrix} - \begin{bmatrix} P_{y1} \end{bmatrix} \begin{bmatrix} h_z \end{bmatrix}$$

$$[A-22] \quad \begin{bmatrix} b_2 \end{bmatrix} = \begin{bmatrix} P_{x2} \end{bmatrix} \begin{bmatrix} h_z \end{bmatrix} - \begin{bmatrix} P_{z2} \end{bmatrix} \begin{bmatrix} h_x \end{bmatrix}$$

$$[A-23] \quad \begin{bmatrix} b_3 \end{bmatrix} = \begin{bmatrix} P_{y3} \end{bmatrix} \begin{bmatrix} h_x \end{bmatrix} - \begin{bmatrix} P_{x3} \end{bmatrix} \begin{bmatrix} h_y \end{bmatrix}$$

$$[A-24] \quad \begin{bmatrix} b_4 \end{bmatrix} = \begin{bmatrix} P_{z1} \end{bmatrix} \begin{bmatrix} h_x \end{bmatrix} - \begin{bmatrix} P_{x1} \end{bmatrix} \begin{bmatrix} h_z \end{bmatrix} + \begin{bmatrix} P_{y2} \end{bmatrix} \begin{bmatrix} h_z \end{bmatrix} - \begin{bmatrix} P_{z2} \end{bmatrix} \begin{bmatrix} h_y \end{bmatrix}$$

$$[A-25] \quad \begin{bmatrix} b_5 \end{bmatrix} = \begin{bmatrix} P_{x1} \end{bmatrix} \begin{bmatrix} h_y \end{bmatrix} - \begin{bmatrix} P_{y1} \end{bmatrix} \begin{bmatrix} h_x \end{bmatrix} + \begin{bmatrix} P_{y3} \end{bmatrix} \begin{bmatrix} h_z \end{bmatrix} - \begin{bmatrix} P_{z3} \end{bmatrix} \begin{bmatrix} h_y \end{bmatrix}$$

$$[A-26] \quad \begin{bmatrix} b_6 \end{bmatrix} = \begin{bmatrix} P_{x2} \end{bmatrix} \begin{bmatrix} h_y \end{bmatrix} - \begin{bmatrix} P_{y2} \end{bmatrix} \begin{bmatrix} h_x \end{bmatrix} + \begin{bmatrix} P_{z3} \end{bmatrix} \begin{bmatrix} h_x \end{bmatrix} - \begin{bmatrix} P_{x3} \end{bmatrix} \begin{bmatrix} h_z \end{bmatrix}$$

$$[A-27] \quad \begin{bmatrix} C_{yz} \end{bmatrix} = \begin{bmatrix} h_y \end{bmatrix}^T \begin{bmatrix} P_{zk} \end{bmatrix} - \begin{bmatrix} h_z \end{bmatrix}^T \begin{bmatrix} P_{yk} \end{bmatrix}$$

$$[A-28] \quad \begin{bmatrix} C_{zx} \end{bmatrix} = \begin{bmatrix} h_z \end{bmatrix}^T \begin{bmatrix} P_{xk} \end{bmatrix} - \begin{bmatrix} h_x \end{bmatrix}^T \begin{bmatrix} P_{zk} \end{bmatrix}$$

$$[A-29] \quad \begin{bmatrix} C_{xy} \end{bmatrix} = \begin{bmatrix} h_x \end{bmatrix}^T \begin{bmatrix} P_{yk} \end{bmatrix} - \begin{bmatrix} h_y \end{bmatrix}^T \begin{bmatrix} P_{xk} \end{bmatrix}$$

$$[A-30] \quad \begin{bmatrix} C_{11} \end{bmatrix} = \begin{bmatrix} h_y \end{bmatrix}^T \begin{bmatrix} m_{zz} \end{bmatrix} \begin{bmatrix} h_y \end{bmatrix} - \begin{bmatrix} h_y \end{bmatrix}^T \begin{bmatrix} m_{zy} \end{bmatrix} \begin{bmatrix} h_z \end{bmatrix}$$





## APPENDIX B--DEVELOPMENT OF ROTATION TRANSFORMATIONS

---

There are 12 possible orthonormal rotation transformations, in terms of Euler angles, that the analyst may choose from in order to orient one orthogonal triad with respect to another. For each one of the 12 orthonormal rotation transformations there is an associated rotation transformation that is not orthonormal and that is used to transform angular velocity projections (onto a nonorthogonal vector basis), which are time derivatives of Euler angles, to projections (onto an orthogonal vector basis) that are commonly referred to as time derivatives of angular quasi-coordinates ( $\omega_x$ ,  $\omega_y$  and  $\omega_z$ ).

It is possible, for purposes of digital computation, to automate the generation of these transformations, given a selected order of rotation. It is the purpose of this appendix to indicate the steps and numerical manipulations that are required. To this end, let us consider one of the 12 types (say a 2-3-2 permutation) as an illustrative example.

Consider the two orthogonal vector bases, whose relative orientation we want to describe, to be

$$[B-1] \quad \{\bar{a}\} = \begin{bmatrix} I \\ J \\ K \end{bmatrix}$$

and

$$[B-2] \quad \{\bar{e}\} = \begin{bmatrix} \bar{i} \\ \bar{j} \\ \bar{k} \end{bmatrix}.$$

Now if  $\theta_1$ ,  $\theta_2$ , and  $\theta_3$  are the three successive Euler rotations about axes (2-3-2) respectively, then it follows that

$$[B-3] \quad \{\bar{a}\} = [T_1]\{\bar{e}'\} \\ = \begin{bmatrix} \cos\theta_1 & & \\ & 1 & \\ -\sin\theta_1 & & \end{bmatrix} \begin{bmatrix} \sin\theta_1 & \\ & \cos\theta_1 \end{bmatrix} \begin{bmatrix} \bar{i}' \\ \bar{j}' \\ \bar{k}' \end{bmatrix},$$

$$\begin{aligned}
 \{\bar{e}'\} &= [T_2]\{\bar{e}''\} \\
 \text{[B-4]} \quad &= \begin{bmatrix} \cos\theta_2 & -\sin\theta_2 & \\ \sin\theta_2 & \cos\theta_2 & \\ & & 1 \end{bmatrix} \begin{bmatrix} \bar{i}'' \\ \bar{j}'' \\ \bar{k}'' \end{bmatrix},
 \end{aligned}$$

and

$$\begin{aligned}
 \{\bar{e}''\} &= [T_3]\{\bar{e}\} \\
 \text{[B-5]} \quad &= \begin{bmatrix} \cos\theta_3 & & \sin\theta_3 \\ & 1 & \\ -\sin\theta_3 & & \cos\theta_3 \end{bmatrix} \begin{bmatrix} \bar{i} \\ \bar{j} \\ \bar{k} \end{bmatrix}.
 \end{aligned}$$

On combining Equations B-3, B-4, and B-5 there results

$$\text{[B-6]} \quad \{\bar{a}\} = [T_1][T_2][T_3]\{\bar{e}\}.$$

Now, a 2-3-2 permutation means that the first rotation ( $\theta_1$ ) is about the 2nd axis of the  $\{\bar{a}\}$  basis, the second rotation ( $\theta_2$ ) is about the 3rd axis of the  $\{\bar{e}'\}$  basis and the third rotation ( $\theta_3$ ) is about the 2nd axis of the  $\{\bar{e}''\}$  basis.

Consider the following reference table, which shows the correlation between Euler rotations and the corresponding axis:

Table B-1 Correlation of Euler Rotations and Axes

Type	1	2	3	4	5	6	7	8	9	10	11	12
$\theta_1$ about	1,I	1,I	1,I	1,I	2,J	2,J	2,J	2,J	3,K	3,K	3,K	3,K
$\theta_2$ about	2, $\bar{j}'$	2, $\bar{j}'$	3, $\bar{k}'$	3, $\bar{k}'$	3, $\bar{k}'$	3, $\bar{k}'$	1, $\bar{i}'$	1, $\bar{i}'$	1, $\bar{i}'$	1, $\bar{i}'$	2, $\bar{j}'$	2, $\bar{j}'$
$\theta_3$ about	3, $\bar{k}''$	1, $\bar{i}''$	1, $\bar{i}''$	2, $\bar{j}''$	1, $\bar{i}''$	2, $\bar{j}''$	2, $\bar{j}''$	3, $\bar{k}''$	2, $\bar{j}''$	3, $\bar{k}''$	3, $\bar{k}''$	1, $\bar{i}''$

Now it is clear that the elementary rotation transformations ( $[T_1]$ ,  $[T_2]$ , and  $[T_3]$ ) always involve  $\theta_1$ ,  $\theta_2$ ,  $\theta_3$  respectively, but any one of them may have three different forms depending on the axis associated with its rotation. That is, when  $\theta_i$  ( $i = 1, 2, 3$ ) is about axis (1) then

$$\text{[B-7]} \quad [T_i] = \begin{bmatrix} 1 & & \\ & \cos\theta_i & -\sin\theta_i \\ & \sin\theta_i & \cos\theta_i \end{bmatrix},$$

when  $\theta_i$  is about axis (2),

$$[B-8] \quad [T_1] = \begin{bmatrix} \cos\theta_1 & \sin\theta_1 \\ -\sin\theta_1 & \cos\theta_1 \end{bmatrix},$$

and finally, when  $\theta_1$  is about axis (3),

$$[B-9] \quad [T_1] = \begin{bmatrix} \cos\theta_1 & -\sin\theta_1 \\ \sin\theta_1 & \cos\theta_1 \end{bmatrix}.$$

Thus, it is evident that one need only specify a rotation type (referring to Table B-1) and the three Euler rotations to create his required orthonormal rotation transformation Equation B-6.

The associated rotational velocity transformations are developed as follows. Consider, again, the 2-3-2 permutation. For this case, it is possible to express the angular velocity vector  $\bar{\omega}$  in two ways:

$$[B-10] \quad \bar{\omega} = \bar{i}\omega_x + \bar{j}\omega_y + \bar{k}\omega_z$$

and as

$$[B-11] \quad \bar{\omega} = \bar{j}\dot{\theta}_1 + \bar{k}\dot{\theta}_2 + \bar{j}\dot{\theta}_3.$$

Combining Equations B-10 with B-11 there results

$$[B-12] \quad \{\omega\} = [\pi]\{\dot{\theta}\},$$

$$\text{or} \quad \begin{bmatrix} \omega_x \\ \omega_y \\ \omega_z \end{bmatrix} = \begin{bmatrix} \cos\theta_3 & -\sin\theta_3 \\ \sin\theta_3 & \cos\theta_3 \end{bmatrix} \begin{bmatrix} \sin\theta_2 & 1 \\ \cos\theta_2 & 1 \end{bmatrix} \begin{bmatrix} \dot{\theta}_1 \\ \dot{\theta}_2 \\ \dot{\theta}_3 \end{bmatrix}$$

$$[B-13] \quad \text{or} \quad [\pi] = [T_3]^T [A]^T.$$

Now, the inverse transformation of Equation B-12 is required for hinge kinematics applications, or it is necessary to express

$$\begin{aligned}
[\pi]^{-1} &= [A]^{T^{-1}} [T_3] \\
&= ([E]^{-1} [E][A]^T)^{-1} [T_3]
\end{aligned}$$

$$\text{[B-14]} \quad = ([E][A]^T)^{-1} [E][T_3]$$

with [E] an elementary row interchange transformation, which for the (2-3-2) example is

$$\text{[B-15]} \quad [E] = \left[ \begin{array}{c|c|c} 1 & & \\ \hline & 1 & \\ \hline & & 1 \end{array} \right]$$

and causes  $([E][A]^T)$  to be of the form:

$$\text{[B-16]} \quad [E][A]^T = \left[ \begin{array}{c|c|c} \alpha & & \\ \hline & 1 & \\ \hline \beta & & 1 \end{array} \right]$$

such that

$$\text{[B-17]} \quad ([E][A]^T)^{-1} = \left[ \begin{array}{c|c|c} 1/\alpha & & \\ \hline & 1 & \\ \hline -\beta/\alpha & & 1 \end{array} \right]$$

with  $\alpha = \sin\theta_2$ ,

and  $\beta = \cos\theta_2$ .

The form of Equation B-17 is the same for all 12 types of Euler rotations, which was the purpose of introducing [E], and this is convenient with respect to programming considerations. It follows that

for types 1, 5, 9  $\alpha = \cos\theta_2, \beta = \sin\theta_2$ ,

for types 2, 6, 10  $\alpha = \sin\theta_2, \beta = \cos\theta_2$ ;

for types 3, 7, 11  $\alpha = -\sin\theta_2, \beta = \cos\theta_2$ ,

and for types 4, 8, 12  $\alpha = \cos\theta_2, \beta = -\sin\theta_2$ .

Also, for each of the 12 types, there is an elementary row interchange transformation [E] that can be constructed from simple inspection of the permutation integers of Table B-1 (2-3-2 for example). In fact, it is unnecessary to actually construct [E] because information to construct it is merely applied to  $[T_3]$  (interchanging its rows), which produces  $[E][T_3]$ . Thus, the velocity transformation of Equation B-14 can be created for any one of the 12 possible types with comparative ease.

APPENDIX C--TIME DERIVATIVES OF KINEMATIC COEFFICIENTS

---

The formulation and numerical implementation of motion equations for the system of interconnected bodies involves a vector of Lagrange multipliers,  $\{\lambda\}$  (Refer to Equations II-1 and II-6). In order to numerically evaluate  $\{\lambda\}$  there is seen to be the requirement of calculating time derivatives of kinematic coefficients (velocity transformations) associated with hinges.

With reference to Chapter II, Section C, it is noted that for each hinge there is a  $[b_p]$  and a  $[b_q]$  matrix of kinematic coefficients. The basic form of these matrices is repeated here, then the sequence of steps necessary to develop their time derivatives is indicated.

The  $[b_p]$  array is

$$[C-1] \quad [b_p] = - \left[ \begin{array}{c|c|c} [\pi]^{-1} \begin{bmatrix} R \\ q \end{bmatrix}_m & [0] & [\pi]^{-1} \begin{bmatrix} R \\ q \end{bmatrix}_m \begin{bmatrix} \sigma \\ p \end{bmatrix} \\ \hline \begin{bmatrix} R \\ p \end{bmatrix}_m \begin{bmatrix} S \\ mp \end{bmatrix}^{(m)} & \begin{bmatrix} R \\ p \end{bmatrix}_m & \begin{bmatrix} R \\ p \end{bmatrix}_m \begin{bmatrix} h \\ p \end{bmatrix} \end{array} \right]$$

and

$$[C-2] \quad [b_q] = \left[ \begin{array}{c|c|c} [\pi]^{-1} \begin{bmatrix} R \\ q \end{bmatrix}_n & [0] & [\pi]^{-1} \begin{bmatrix} R \\ q \end{bmatrix}_n \begin{bmatrix} \sigma \\ q \end{bmatrix} \\ \hline \begin{bmatrix} R \\ p \end{bmatrix}_n \begin{bmatrix} S \\ nq \end{bmatrix}^{(n)} & \begin{bmatrix} R \\ p \end{bmatrix}_n & \begin{bmatrix} R \\ p \end{bmatrix}_n \begin{bmatrix} h \\ q \end{bmatrix} \end{array} \right].$$

Now to develop  $[\dot{b}_p]$  and  $[\dot{b}_q]$  it is necessary to expand the following as:

$$[C-3] \quad \frac{d}{dt} \left( [\pi]^{-1} \begin{bmatrix} R \\ q \end{bmatrix}_m \right) = [\dot{\pi}^{-1}] \begin{bmatrix} R \\ q \end{bmatrix}_m + [\pi]^{-1} \left( \begin{bmatrix} \dot{R} \\ q \end{bmatrix}_p \begin{bmatrix} R \\ p \end{bmatrix}_m + \begin{bmatrix} R \\ q \end{bmatrix}_p \begin{bmatrix} \dot{R} \\ p \end{bmatrix}_m \right),$$

$$[C-4] \quad \frac{d}{dt} \left( \begin{bmatrix} R \\ p \end{bmatrix}_m \begin{bmatrix} S \\ mp \end{bmatrix}^{(m)} \right) = \begin{bmatrix} \dot{R} \\ p \end{bmatrix}_m \begin{bmatrix} S \\ mp \end{bmatrix}^{(m)} + \begin{bmatrix} R \\ p \end{bmatrix}_m \begin{bmatrix} \dot{S} \\ mp \end{bmatrix}^{(m)},$$

$$[C-5] \quad \frac{d}{dt} \left( [\pi]^{-1} \begin{bmatrix} R \\ q \end{bmatrix}_n \right) = [\dot{\pi}^{-1}] \begin{bmatrix} R \\ q \end{bmatrix}_n + [\pi]^{-1} \begin{bmatrix} \dot{R} \\ q \end{bmatrix}_n$$

and

$$[C-6] \quad \frac{d}{dt} \left( \begin{bmatrix} p & R & n \\ S & (n) & nq \end{bmatrix} \right) = \begin{bmatrix} p & \dot{R} & n \\ S & (n) & nq \end{bmatrix} + \begin{bmatrix} p & R & n \\ \dot{S} & (n) & nq \end{bmatrix}.$$

The 3x3 matrix time derivatives defined by Equations C-3 through C-6 have factors (also 3x3 matrix time derivatives) that are expanded in terms of previously defined quantities as follows:

$$[C-7] \quad \begin{bmatrix} p & \dot{R} & m \\ S & (m) & mq \end{bmatrix} = \left[ SK^* \left( \begin{bmatrix} p & R & m \\ \sigma & p & \{\dot{\xi}_m\} \end{bmatrix} \right) \right] \begin{bmatrix} p & R & m \\ S & (m) & mq \end{bmatrix},$$

$$[C-8] \quad \begin{bmatrix} q & \dot{R} & n \\ S & (n) & nq \end{bmatrix} = \left[ SK^* \left( \begin{bmatrix} q & R & n \\ \sigma & q & \{\dot{\xi}_n\} \end{bmatrix} \right) \right] \begin{bmatrix} q & R & n \\ S & (n) & nq \end{bmatrix},$$

$$[C-9] \quad \begin{bmatrix} p & \dot{R} & q \\ S & (p) & pq \end{bmatrix} = \begin{bmatrix} \Omega & (p) \\ p & q \end{bmatrix} \begin{bmatrix} p & R & q \\ S & (p) & pq \end{bmatrix},$$

with

$$[C-10] \quad \begin{bmatrix} \Omega & (p) \\ p & q \end{bmatrix} = SK^* \left( \begin{bmatrix} p & R & m \\ \omega & m & \{\dot{\xi}_m\} \end{bmatrix} \right) - \begin{bmatrix} p & R & q \\ q & R & n \end{bmatrix} \left( \begin{bmatrix} \omega & n & \{\dot{\xi}_n\} \end{bmatrix} \right),$$

$$[C-11] \quad \begin{bmatrix} p & \dot{R} & n \\ S & (n) & nq \end{bmatrix} = \begin{bmatrix} p & \dot{R} & q \\ S & (p) & pq \end{bmatrix} \begin{bmatrix} q & R & n \\ S & (n) & nq \end{bmatrix} + \begin{bmatrix} p & R & q \\ S & (p) & pq \end{bmatrix} \begin{bmatrix} q & \dot{R} & n \\ S & (n) & nq \end{bmatrix},$$

$$[C-12] \quad \begin{bmatrix} \dot{S} & (m) \\ S & (m) & mq \end{bmatrix} = \left[ SK^* \left( \begin{bmatrix} h & p & \{\dot{\xi}_m\} \end{bmatrix} \right) \right],$$

$$[C-13] \quad \begin{bmatrix} \dot{S} & (n) \\ S & (n) & nq \end{bmatrix} = \left[ SK^* \left( \begin{bmatrix} h & q & \{\dot{\xi}_n\} \end{bmatrix} \right) \right].$$

Finally, the time derivative of  $[\pi]^{-1}$  requires additional consideration. Refer to Appendix B.

The rotation transformation  $[\pi]^{-1}$  is developed as

$$[C-14] \quad [\pi]^{-1} = \left( \begin{bmatrix} E & A \\ E & T_3 \end{bmatrix} \right)^{-1} \begin{bmatrix} E & T_3 \end{bmatrix},$$

and it is shown that the form

$$[C-15] \quad \left( \begin{bmatrix} E & A \\ E & T_3 \end{bmatrix} \right)^{-1} = \begin{bmatrix} \tilde{A} \\ \tilde{A} \end{bmatrix} = \begin{bmatrix} 1/\alpha & & & \\ & 1 & & \\ -\beta/\alpha & & & 1 \end{bmatrix}$$

holds for each of the 12 possible Euler rotations. In that  $[E]$  is constant,  $[\tilde{A}]$  depends *only* on  $\theta_2$  and  $[T_3]$  depends *only* on  $\theta_3$ , it follows that

$$\begin{aligned}
 \text{[C-16]} \quad \frac{d}{dt} [\pi]^{-1} &= \dot{\theta}_2 \frac{\partial}{\partial \theta_2} [\tilde{A}] [E] [T_3] \\
 &+ \dot{\theta}_3 \left( [\tilde{A}] [E] \right) \frac{\partial}{\partial \theta_3} [T_3] ,
 \end{aligned}$$

where the Euler angle rates ( $\dot{\theta}_2$  and  $\dot{\theta}_3$ ) are numerically evaluated before their use in Equation C-16 through application of Equation II-3; that is, they reside in that part of the state vector time derivative  $\{\dot{y}\}$  that has been evaluated.

## APPENDIX D--MONITOR OF SYSTEM MOMENTA AND ENERGIES

---

Development of state equations for predicting dynamic response of a system of interconnected flexible bodies involves a considerable amount of complicated formulation and programming code. This is certainly a true statement, independent of the particular method of analytical mechanics on which one might select to base development.

The inherent complexity of such a digital simulation program gives rise to the question: is there any way of checking the program validity? In an attempt to answer this question, one might suggest comparing results with those of other dynamic simulations or hardware tests. If such a comparison is positive, then credibility (to a degree) is established. However, there is another absolutely necessary (if not sufficient) condition that must be passed to establish validity. For a dynamic system free of external forces and torques, angular and linear momenta must be conserved; also, total energy (kinetic plus potential) must not increase in time.

It is a desirable feature for such a digital simulation program to have a built-in monitor of momenta and energy. The purpose of this appendix is to develop (in terms of previously identified state variables and system parameters) the expressions for total system angular and linear momentum vectors and the total system energy.

The total angular momentum about the inertial reference can be expressed (from definition) as

$$[D-1] \quad \bar{H} = \sum_{j=1}^{NB} \int_{V_j} (\bar{x} \times \bar{v}) \, dm$$

with the summation over the number of bodies (NB) of the system, with  $\bar{x}$  being the vector positioning the elemental mass (dm) from the inertial origin, with  $\bar{v}$  being the absolute velocity of dm, and with integration taken over the volume of the  $j^{th}$  body ( $V_j$ ).

Also, from definition, the total linear momentum with respect to the inertial frame is



$$[D-2] \quad \bar{L} = \sum_{j=1}^{NB} \int_{V_j} \bar{v} \, dm.$$

Now, consistent with the notion of a body fixed axis system and with a consistent velocity field assumed (Refer to Chapter II, Section B.), it follows that, over the volume of the  $j^{th}$  body,

$$[D-3] \quad \bar{x} = \bar{x}_{Rj} + \bar{\rho}_0 + \bar{\eta},$$

and

$$[D-4] \quad \bar{v} = \bar{v}_{Rj} + \bar{\omega}_j \times (\bar{\rho}_0 + \bar{\eta}) + \bar{\phi}_k \dot{\xi}_k.$$

On substituting Equations D-3 and D-4 into D-1 and D-2 and integrating, it becomes clear that the first six elements of the product

$$[D-5] \quad \{p\}_j = [m]_j \{U\}_j \\ = \begin{bmatrix} \{p_\omega\} \\ \{p_v\} \\ \{p_\xi\} \end{bmatrix}_j$$

are projections of the  $j^{th}$  body's angular and linear momentum vectors onto the moving body axis system. In fact,  $\{p_\omega\}$  includes the effect of momentum wheels (See Equation II-109), which surely must be accounted for.

Thus, the angular momentum of the  $j^{th}$  body (about its body-origin) is

$$[D-6] \quad \bar{h}_j = [\bar{e}_j] \{p_\omega\}_j,$$

while the linear momentum of the  $j^{th}$  body is

$$[D-7] \quad \bar{l}_j = [\bar{e}_j] \{p_v\}_j$$

where  $[\bar{e}_j]$  is the unit vector basis associated with the body fixed reference triad.

Now rotation transformations that relate vector components in each body system to the inertial system exist; also, position vector from the inertial origin to the reference point of each body exists. It follows that

$$[D-8] \quad \bar{L} = \sum_{j=1}^{NB} \bar{l}_j \\ = \sum_{j=1}^{NB} [{}^0R_j] \{p_v\}_j,$$

and that

$$[D-9] \quad \bar{H} = \sum_{j=1}^{NB} \left( \bar{h}_j + \bar{x}_{Rj} \times \bar{l}_j \right) \\ = \sum_{j=1}^{NB} \left( [{}^0R_j] \{p_\omega\}_j + [SK* \left( [{}^0R_j] \{p_v\} \right)] \{x_R\}_j \right).$$

The total angular and linear momentum vectors are calculated by the program in the manner indicated in Equations D-8 and D-9. For a variety of torque/force-free configurations that have been examined, momentum has been conserved within acceptable numerical tolerances.

The total energy is calculated (Refer to Equations II-38 and II-42.) as

$$[D-10] \quad T + V = \frac{1}{2} \sum_{j=1}^{NB} \left( [U]_j [m]_j \{U\}_j + \right. \\ \left. [\xi]_j [k]_j \{\xi\}_j \right).$$

The kinetic energy contribution of embedded momentum wheels is included (as it must be), because  $[m]_j$  includes momentum wheel inertial coupling terms and  $\{U\}_j$  includes momentum wheel spin rates ( $\dot{\theta}_s$ ).

Potential energy, additional to that shown in Equation D-10, comes about in the event that there is a "sprung" hinge; say for example, associated with the  $\beta_k$  coordinate. If the spring force/torque is linear with  $\beta_k$ , then additional potential energy is

$$[D-11] \quad \checkmark \text{ (additional)} = \frac{1}{2} \sum_k K_k \beta_k^2.$$

## APPENDIX E--ROOT LOCUS SOLUTION TECHNIQUES

---

The Root Locus solution procedure that is included in the digital program was supplied by Goddard Space Flight Center (GSFC) personnel and is included here for completeness. The following discussion has been extracted from GSFC Branch Report No 254 dated October 2, 1973 (Mr. Raymond V. Welch, author).

Two expressions are identified as the basis for initiating the solution process.

$$[E-1] \quad \left| K \frac{P(s)}{Q(s)} \right| = 1$$

$$[E-2] \quad \angle \frac{P(s)}{Q(s)} = 180^\circ \quad K \geq 0$$

Expressions E-1 and E-2 contain polynomial expressions for the conventional open loop expression

$$[E-3] \quad KG(s)H(s) = KP(s)/Q(s).$$

The solution process requires a starting point (known to lie somewhere on the loci) from which to generate the desired locus; therefore, assume there exists a known value of  $s$ , say  $s_0$ , such that

$$[E-4] \quad \angle \frac{P(s_0)}{Q(s_0)} = 180^\circ$$

i.e.,  $s_0$  is a point on the locus. A good starting point might be an open loop pole or zero as these points are usually known *a priori*; however, any point along the branch of the locus to be determined may be used. The locus is then traced using the following procedure.

### Step 1

Draw a "small" circle of radius  $r$  centered at  $s_0$  and define  $s_c$  to be the values of  $s$  which lie on this circle (See Figure E-1.). These values of  $s_c$  are determined analytically by:

$$[E-5] \quad s_c = s_0 + re^{j\theta}$$

where  $\theta$  is measured as the angle generated by a counterclockwise rotation from the positive real axis of the  $s$ -plane. If the locus does not terminate inside the circle, then there must exist at least two values of  $\theta$  between zero and 360 degrees such that

$$[E-6] \quad \angle \frac{P(s_c)}{Q(s_c)} = 180^\circ$$

(More than two values of  $\theta$  will exist that satisfy this equation if breakway points of the locus are encircled or if the circle is large enough to intersect other branches of the locus. Consequently, to avoid changing branches,  $r$  must be kept smaller than the distance between the branches of the locus). Suppose that for  $\theta = \theta_1$  and  $\theta = \theta_2$  the above equation is satisfied, then  $s_{c1}$  and  $s_{c2}$  are points on the locus where

$$[E-7] \quad s_{c1} = s_o + re^{j\theta_1}$$

$$s_{c2} = s_o + re^{j\theta_2}$$

See Figure E-1. These roots are found by an iterative process.

### Step 2

Define  $\psi(\theta)$  by

$$[E-8] \quad \psi(\theta) = \angle \frac{P(s_c)}{Q(s_c)}$$

where  $s_c$  is defined above and  $\theta$  is any arbitrary angle. If  $\psi(\theta)$  does not equal 180 degrees increment  $\theta$  by  $\Delta\theta$  and reevaluate  $\psi(\theta)$ . Continue this process until  $\psi(\theta)$  passes through 180 degrees. ( $\psi(\theta)$  is a monotonic function across the locus, thus  $\psi(\theta)$  crossing 180 degrees implies the locus has been crossed). When  $\psi(\theta)$  passes through 180 degrees, redefine  $\Delta\theta$  as

$$[E-9] \quad \Delta\theta_{\text{new}} = -K\Delta\theta_{\text{old}}; \quad 0 < K < 1$$

and again calculate  $\psi(\theta)$ . If  $\psi(\theta)$  does not equal 180 degrees for this point, increment  $\theta$  by this new  $\Delta\theta$  and recalculate  $\psi(\theta)$ . Continue this process until  $\psi(\theta)$  again crosses 180 degrees. Reduce  $\Delta\theta$  again as above and repeat the previous operation until  $\Delta\theta = \delta$ , where  $\delta$  is some predefined small positive number. At this time  $\psi(\theta)$  will be  $180 \pm \epsilon$  degrees, where  $\epsilon$  is a "small" angle whose size is a function of  $\delta$ ; thus a root on the locus has been found. This root is either  $s_{c1}$  or  $s_{c2}$ , depending on the initial choice of  $\theta$  and on the initial sign of  $\Delta\theta$ . For this subprogram, the initial

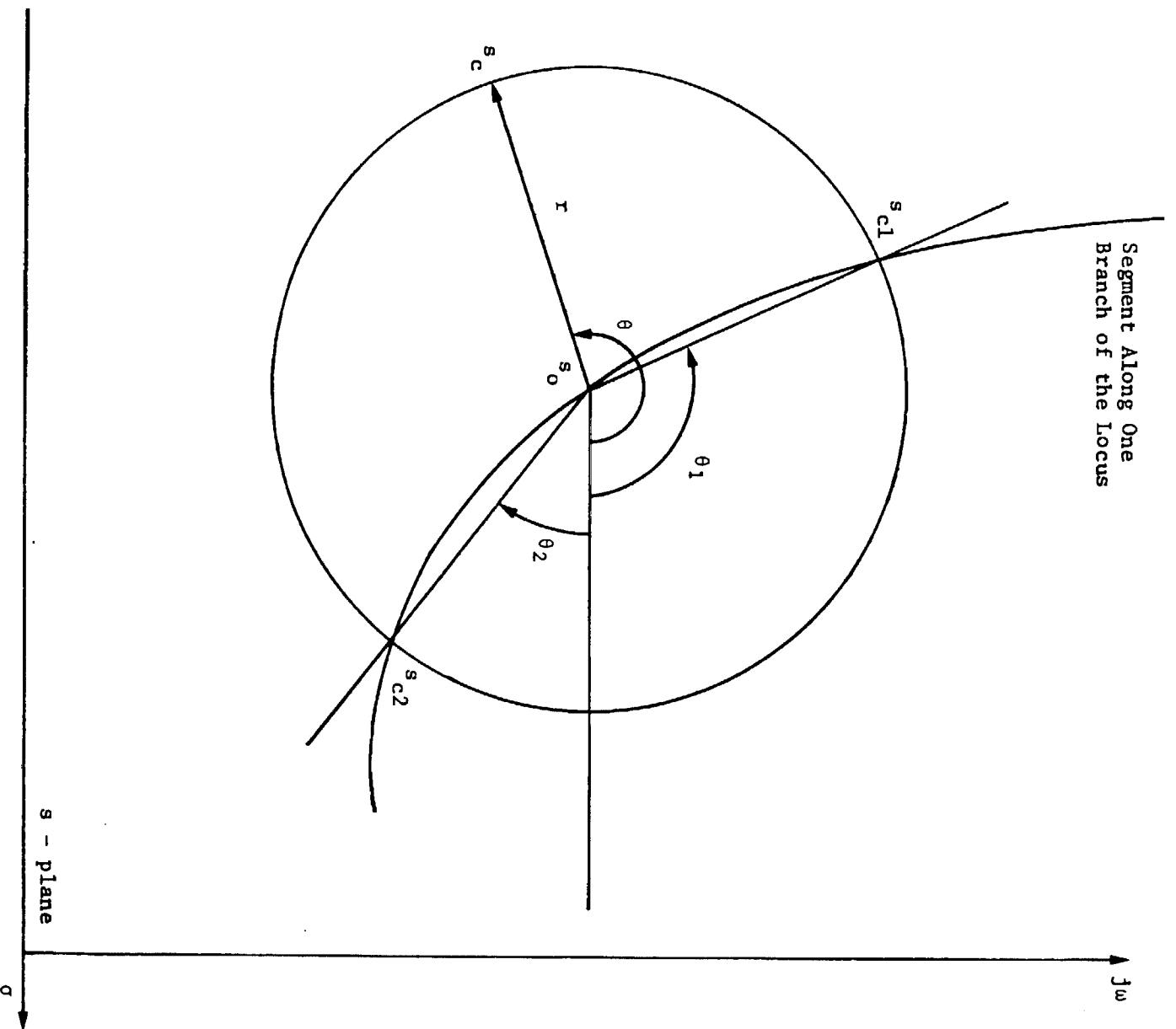

Figure E-1 Variable Definitions at Starting Point of Locus

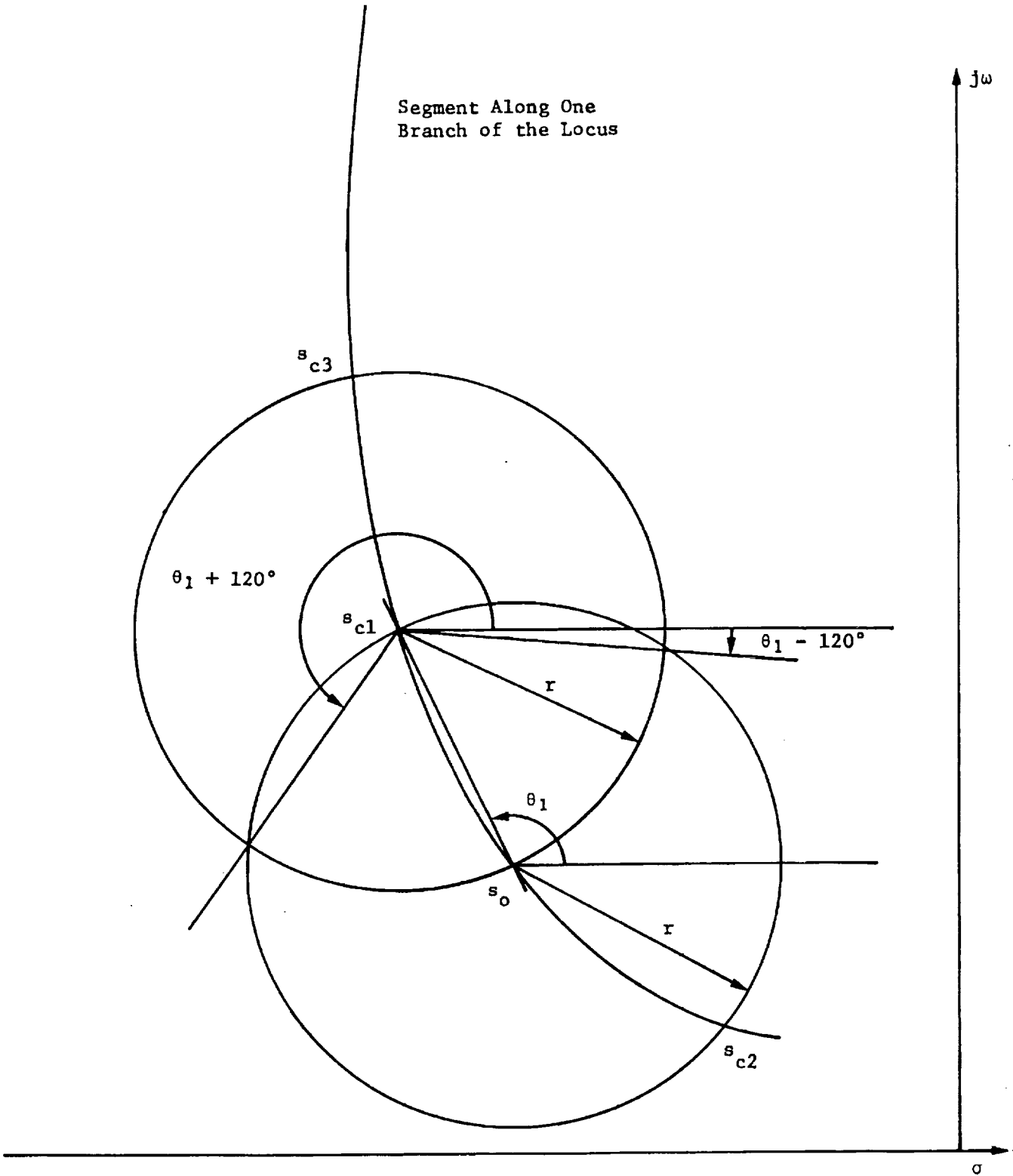

Figure E-2 Search Area Definition for Finding Roots After the First Root is Found.

value of  $\theta$  is optional, but if no choice is made a value of 180 degrees is used. Also the initial increment  $\Delta\theta$  is set at 10 degrees with the change in  $\Delta\theta$  for every 180 degrees crossing defined by

$$[\text{E-10}] \quad \Delta\theta_{\text{new}} = -\frac{1}{10} \Delta\theta_{\text{old}}$$

It was found that  $\delta = 10^{-8}$  degrees was sufficiently small to insure  $\epsilon < .001$  degrees except possibly for values of  $s$  near the open loop poles or zeros. Assume that  $\theta$  is chosen initially so that the root found is located at the point  $s_{c1}$  as defined above and as shown in Figure E-1, and suppose it is desired to continue the locus in this direction.

### Step 3

Draw a circle of radius  $r$  centered at  $s_{c1}$ . Again if the locus does not terminate inside the circle, the locus will intersect the circle in at least two points. Because the circles located at  $s_o$  and  $s_{c1}$  are of equal radius, one of these points is  $s_o$  as shown in Figure E-2. This root is eliminated from the search routine by restricting the range of  $\theta$  to

$$[\text{E-11}] \quad \theta_1 - 120^\circ < \theta < \theta_1 + 120^\circ$$

These limits are chosen as they are the points where the circles located at  $s_o$  and  $s_{c1}$  intersect. Thus the search for a new root is conducted only in a previously unsearched region. The initial angle is chosen at  $\theta = \theta_1 - 120$  degrees with  $\Delta\theta > 0$  and step 2 is repeated until  $\Delta\theta = \delta$ , i.e., another root is found.

### Step 4

Draw a circle of radius  $r$  centered at the root found in the previous step and repeat Step 2 with the restrictions on  $\theta$  as defined in Step 3.

Repeating Step 4, the roots along one branch of the locus are determined. The value of the gain,  $K$ , for each of these roots is calculated from

$$[\text{E-12}] \quad K = \left| \frac{Q(s)}{P(s)} \right|.$$

**TYPICAL MULTIBODY CONFIGURATION**

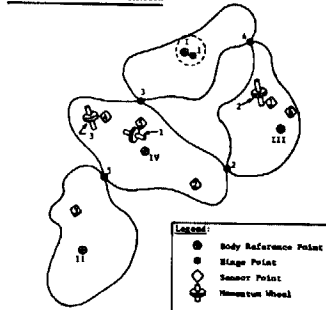

- Notes:**
- All connector wheels must also have a sensor point.
  - Body I must always be positioned relative to the inertial reference.
  - Hinge I is always between Body I and the inertial reference.

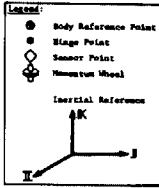

**TYPICAL TWO BODY/HINGE POINT ARRANGEMENT**

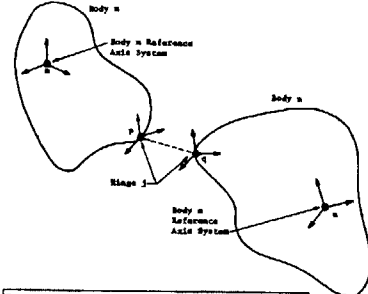

- Notes:**
- Motion of the q frame on Body n is measured relative to the p frame on Body m.
  - The p and q frames are positioned with respect to Body n and a reference axis system.
  - Hinge j is identified via array ITOPCL.
  - Array IMDATA contains additional hinge information.

**PROGRAM SIMULATION INTERFACE ARRAYS**

**ITOPCL** Topology, Size = 3 x NN

Hinge No.	1 2 3 4 5	Body n has frame q
Body No.	1 3 4 5 1	Body m has frame p
	0 4 1 1 4	

Example: Refer to Column 3 (Hinge 3) and note Body 4 intersects with Body 1 via Hinge 3.

**INCPKX** No. of Elastic Modes/Body, Size = 1 x NN

Body No.	1 2 3 4
	5 0 0 2

Example: Body No. 4 has 2 elastic modes, Body No. 2 has no elastic modes.

**IPTSM** Sensor Point Locations, Size = 1 x NN

Sumner Pt.	1 2 3 4 5 6
	3 4 2 4 4 1

Example: Sumner Point 4 is located on Body 4 (see also Sensor Points 4 and 6).

**IMDATA** Hinge Information, Size = 7 x NN

	1 2 3 4 5	Hinge No.
ITYPE	2 2 2 2 4	
$\delta_1$	0 0 0 1 0	
$\delta_2$	0 0 0 1 2	
$\delta_3$	0 0 0 0 1	
$\delta_4$	0 1 1 1 1	
$\delta_5$	0 1 0 1 1	
$\delta_6$	0 1 1 1 0	

**Notes:**

- ITYPE = Euler Type
- Eliminate in rows 2-7 identify hinge constraint type.
- 0: Free/locked
- 1: Fixed Constraint (Same relative velocity)
- 2: Rheonomic Constraint (time dependent)

- Additional Remarks:**
- The number of zeros in the state vector equals the sum of "zeros" plus the sum of the "ones" (excluding row 1) in the array.
  - The number of Lambdas (constraints) equals the number of "nonzeros" (excluding row 1) in the array.

**IMD** Momentum Wheel Information, Size = 3 x NNPD and 2 x NNPD

	1 2 3	Momentum Wheel No.
	5 1 4	Sensor Point No.
	2 1 3	Spin Axis (1, 2, or 3)
	1 1 0	1 = Active; 0 = Constant Speed
	$\delta_1 \delta_2 \delta_3$	Wheel Rates (Initial)
	$J_1 J_2 J_3$	Wheel Inertia about Spin Axis

**EULER ANGLE PERMUTATION CANDIDATES - ITYPE**

**ITYPE** - 1 2 3 4 5 6 7 8 9 10 11 12

1st Rotation	Axis of $\theta_1$	1 1 1 1 2 2 2 3 3 3 3
2nd Rotation	Axis of $\theta_2$	2 2 3 3 3 3 1 1 1 1 2 2
3rd Rotation	Axis of $\theta_3$	3 1 1 2 1 2 2 2 3 3 3 1

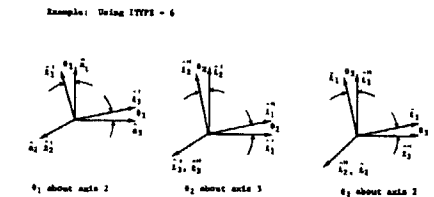

$\theta_1$  about axis 2

$$\begin{bmatrix} c_1 & 0 & -s_1 \\ s_1 & 0 & 0 \\ 0 & 1 & 0 \end{bmatrix} \begin{bmatrix} c_2 & 0 & -s_2 \\ s_2 & 0 & 0 \\ 0 & 1 & 0 \end{bmatrix} \begin{bmatrix} c_3 & 0 & -s_3 \\ s_3 & 0 & 0 \\ 0 & 1 & 0 \end{bmatrix} \begin{bmatrix} a_1 \\ a_2 \\ a_3 \end{bmatrix}$$

also  $\hat{e}_i = \hat{h}_j \hat{k}_3$

**CONSOLIDATION OF KINEMATICAL COEFFICIENTS**

(The "b" Coefficients)

	1	2	3	4	
1	q				$(b)_1$
2		q			$(b)_2$
3			q		$(b)_3$
4				q	$(b)_4$
5					$(b)_5$

- Notes:**
- Only a single entry is in partition for Hinge 1 and it is a q type partition from the connection kinematical array above.
  - All other row partitions have both a p and a q coefficient for each "hinge" between contiguous bodies.

**CONNECTION KINEMATICS - TYPICAL HINGE**

"q" Point      "p" Point

$$\begin{bmatrix} \delta \dot{\theta}_1 \\ \delta \dot{\theta}_2 \\ \delta \dot{\theta}_3 \\ \delta \dot{u}_1 \\ \delta \dot{u}_2 \\ \delta \dot{u}_3 \end{bmatrix} = \begin{bmatrix} -s_1^2 \theta_2 \theta_3 & -s_1^2 \theta_2 \theta_3 \theta_4 & -s_1^2 \theta_3 & s_1^{-1} \theta_2 \theta_3 \\ s_1^2 \theta_2 \theta_3 & s_1^2 \theta_2 \theta_3 \theta_4 & s_1^2 \theta_3 & -s_1^{-1} \theta_2 \theta_3 \\ s_1 \theta_2 \theta_3 & s_1 \theta_2 \theta_3 \theta_4 & s_1 \theta_3 & s_1^{-1} \theta_2 \theta_3 \\ s_1 \theta_2 \theta_3 & s_1 \theta_2 \theta_3 \theta_4 & s_1 \theta_3 & -s_1^{-1} \theta_2 \theta_3 \\ s_1 \theta_2 \theta_3 & s_1 \theta_2 \theta_3 \theta_4 & s_1 \theta_3 & s_1^{-1} \theta_2 \theta_3 \\ s_1 \theta_2 \theta_3 & s_1 \theta_2 \theta_3 \theta_4 & s_1 \theta_3 & s_1^{-1} \theta_2 \theta_3 \end{bmatrix} \begin{bmatrix} \dot{\theta}_1 \\ \dot{\theta}_2 \\ \dot{\theta}_3 \\ \dot{u}_1 \\ \dot{u}_2 \\ \dot{u}_3 \end{bmatrix}$$

**Notes:**

- $s_{ij}$  is a rotation transformation from the j to the i reference frame.
- In general,  $s_{ij} s_{jk} = s_{ik}$  and  $s_{ij}^{-1}$  is a transformation relating Euler rates to body axis projections of the angular velocity vector.
- $\theta_i$  is a nodal slope matrix in the i frame.
- $h_i$  is a nodal deflection matrix in the i frame.
- $s_{ij}$  is a skew symmetric matrix whose elements are the components of the vector i to j in the i frame.

**STATE VECTOR ARRANGEMENT**

**CONSTRAINT FORCE/TORQUE VECTOR**

$$(v) = \begin{bmatrix} (v)_1 \\ (v)_2 \\ (v)_3 \\ (v)_4 \\ (v)_5 \\ (v)_6 \\ (v)_7 \\ (v)_8 \\ (v)_9 \\ (v)_{10} \\ (v)_{11} \\ (v)_{12} \\ (v)_{13} \\ (v)_{14} \\ (v)_{15} \\ (v)_{16} \\ (v)_{17} \\ (v)_{18} \\ (v)_{19} \\ (v)_{20} \end{bmatrix}; \quad (q) = \begin{bmatrix} (q)_1 \\ (q)_2 \\ (q)_3 \\ (q)_4 \\ (q)_5 \\ (q)_6 \\ (q)_7 \\ (q)_8 \\ (q)_9 \\ (q)_{10} \\ (q)_{11} \\ (q)_{12} \\ (q)_{13} \\ (q)_{14} \\ (q)_{15} \\ (q)_{16} \\ (q)_{17} \\ (q)_{18} \\ (q)_{19} \\ (q)_{20} \end{bmatrix}$$

where  $(v)_j = \begin{bmatrix} v_x \\ v_y \\ v_z \\ \omega_x \\ \omega_y \\ \omega_z \\ \dot{u}_1 \\ \dot{u}_2 \\ \dot{u}_3 \\ \dot{\theta}_1 \\ \dot{\theta}_2 \\ \dot{\theta}_3 \end{bmatrix}_j$

For this example, prescribed as function of time, i.e., a rheonomic constraint as used in IMDATA

Figure F-1 Simulation Nomenclature F-1