

NASA TECHNICAL NOTE



NASA TN D-8202 *CL*

NASA TN D-8202

LOAN COPY: RETI
AFWL TECHNICAL
KIRTLAND AFB,



SOME EFFECTS OF ADVERSE WEATHER CONDITIONS ON PERFORMANCE OF AIRPLANE ANTISKID BRAKING SYSTEMS

*Walter B. Horne, John L. McCarty,
and John A. Tanner*

*Langley Research Center
Hampton, Va. 23665*

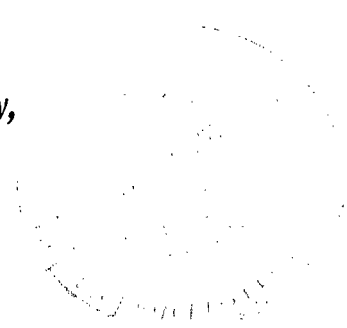



0133761

1. Report No. NASA TN D-8202	2. Government Accession No.	3. Recipient's Catalog No.	
4. Title and Subtitle SOME EFFECTS OF ADVERSE WEATHER CONDITIONS ON PERFORMANCE OF AIRPLANE ANTISKID BRAKING SYSTEMS		5. Report Date July 1976	
		6. Performing Organization Code	
7. Author(s) Walter B. Horne, John L. McCarty, and John A. Tanner		8. Performing Organization Report No. L-10690	
9. Performing Organization Name and Address NASA Langley Research Center Hampton, Va. 23665		10. Work Unit No. 505-08-31-01	
		11. Contract or Grant No.	
12. Sponsoring Agency Name and Address National Aeronautics and Space Administration Washington, D.C. 20546		13. Type of Report and Period Covered Technical Note	
		14. Sponsoring Agency Code	
15. Supplementary Notes			
16. Abstract <p>The performance of current antiskid braking systems operating under adverse weather conditions was analyzed in an effort to both identify the causes of locked-wheel skids which sometimes occur when the runway is slippery and to find possible solutions to this operational problem. This analysis was made possible by the quantitative test data provided by recently completed landing research programs using fully instrumented flight test airplanes and was further supported by tests performed at the Langley aircraft landing loads and traction facility. The antiskid system logic for brake control and for both touchdown and locked-wheel protection is described and its response behavior in adverse weather is discussed in detail with the aid of available data. The analysis indicates that the operational performance of the antiskid logic circuits is highly dependent upon wheel spin-up acceleration and can be adversely affected by certain pilot braking inputs when accelerations are low. Normal antiskid performance is assured if the tire-to-runway traction is sufficient to provide high wheel spin-up accelerations or if the system is provided a continuous, accurate ground speed reference. The design of antiskid systems is complicated by the necessity for trade-offs between tire braking and cornering capabilities, both of which are necessary to provide safe operations in the presence of cross winds, particularly under slippery runway conditions.</p>			
17. Key Words (Suggested by Author(s)) Braking Antiskid systems Adverse weather Landing operations		18. Distribution Statement Unclassified - Unlimited Subject Category 03	
19. Security Classif. (of this report) Unclassified	20. Security Classif. (of this page) Unclassified	21. No. of Pages 31	22. Price* \$3.75

SOME EFFECTS OF ADVERSE WEATHER CONDITIONS ON PERFORMANCE OF AIRPLANE ANTISKID BRAKING SYSTEMS

Walter B. Horne, John L. McCarty, and John A. Tanner
Langley Research Center

SUMMARY

The performance of current antiskid braking systems operating under adverse weather conditions was analyzed in an effort to both identify the causes of locked-wheel skids which sometimes occur when the runway is slippery and to find possible solutions to this operational problem. This analysis was made possible by the quantitative test data provided by recently completed landing research programs using fully instrumented flight test airplanes and was further supported by tests performed at the Langley aircraft landing loads and traction facility. The antiskid system logic for brake control and for both touchdown and locked-wheel protection is described and its response behavior in adverse weather is discussed in detail with the aid of available data. The analysis indicates that the operational performance of the antiskid logic circuits is highly dependent upon wheel spin-up acceleration and can be adversely affected by certain pilot braking inputs when accelerations are low. Normal antiskid performance is assured if the tire-to-runway traction is sufficient to provide high wheel spin-up accelerations or if the system is provided a continuous, accurate ground speed reference. The design of antiskid systems is complicated by the necessity for trade-offs between tire braking and cornering capabilities, both of which are necessary to provide safe operations in the presence of cross winds, particularly under slippery runway conditions.

INTRODUCTION

Operating statistics of modern jet transport airplanes indicate that the antiskid braking systems used on these airplanes are both effective and dependable. The several million landings that are made each year in routine fashion with no serious operating problems attest to this fact. However, as pointed out in reference 1, approximately 30 to 40 landing incidents or accidents are reported each year in which the pilot could not control the airplane sufficiently to prevent the airplane from either overrunning the end of the runway or departing from the side of it. Most of these reported skidding incidents or accidents occur during adverse weather conditions when the runway is damp, flooded, or covered with ice, snow, or slush. Many other skidding incidents also occur each year under such conditions but go unreported.

Historically, airplane skidding accidents under adverse conditions result most often in hull damage to the airplane with occasional passenger and crew injuries, but seldom is there loss of life. However, the potential does exist for catastrophic skidding accidents to occur, especially since the advent of wide-body jet transports carrying large numbers of passengers. Thus, a need exists to uncover and to eliminate the causes for skidding.

Studies of airplane skidding incidents and accidents have revealed that there were a considerable number of instances in which skid patches (flat spots) were found on the tires during post incident/accident inspection; this would indicate that the wheels had locked up. However, in many of these instances, inspection also showed that all elements of the landing gear system, including wheels, brakes, and skid-control units, were operating properly and within their respective tolerances. The fact that wheel skids were occurring with normally functioning antiskid systems suggested the possibility that inaccurate or erroneous information was being supplied to the antiskid logic circuits when slippery runway conditions existed.

It is, of course, highly desirable to avoid wheel lockups because they lead to tire blowouts on high friction surfaces, they reduce braking friction on wet surfaces, and they cause a complete loss of steering control on all surfaces. (See refs. 2 and 3 for examples.) However, it should be pointed out that, even without wheel lockups, landing incidents or accidents that occur when the airplane departs the runway may still be a problem due to insufficient tire-runway traction.

The purpose of this paper is to analyze the performance of antiskid braking systems under adverse weather conditions in an effort to both identify the causes of locked-wheel skids that sometimes occur when the runway is slippery and to find possible solutions to this operational problem. This analysis is made possible by a large amount of data that were obtained under actual and simulated adverse weather conditions during the recently completed landing research programs involving the Federal Aviation Administration (FAA), the United States Air Force (USAF), and the National Aeronautics and Space Administration (NASA). Fully instrumented flight test airplanes such as the Boeing B-727, Boeing B-737, McDonnell Douglas DC-9, Lockheed L-1011, General Dynamics CV-990, Lockheed C-141, and McDonnell Douglas F-4 were used in the investigation. (See refs. 1 and 4 to 8.) In addition, supporting data were recently generated at the Langley aircraft landing loads and traction facility in a program designed to study the performance of various operational skid-control devices over a range of surface wetness conditions.

WHEEL SPIN-UP CHARACTERISTICS

The precision of the antiskid control systems over braked wheel motion depends to a great extent upon wheel spin-up characteristics. Proper operation of the antiskid

system requires positive wheel acceleration after touchdown and after brake release following spin-down. This section of the paper discusses wheel spin-up characteristics, especially under adverse weather conditions, by examining the wheel equation of motion and by presenting some tire hydroplaning considerations.

Equation of Motion

The external forces and moments acting on an airplane wheel under braked rolling conditions are identified in figure 1. The equation of motion which relates the net torques or moments acting on the wheel may be written as follows:

$$(W - L)\mu r_1 + F_w r_1 \pm (W - L)x_c - T_b = I\alpha$$

where

- W fraction of airplane weight supported by a wheel and tire
- L fraction of airplane lift acting on a wheel and tire
- μ tire-ground friction coefficient (includes unbraked rolling resistance)
- r_1 radius of loaded tire, Tire free radius - Vertical tire deflection
- F_w fluid drag acting on tire (zero on dry surface)
- x_c fore-and-aft location of wheel ground reaction with respect to axle center line
- T_b brake torque acting on wheel
- I moment of inertia of tire, wheel, and rotating parts of wheel brake
- α wheel angular acceleration (positive during wheel spin-up)

The first term in the equation, $(W - L)\mu r_1$, is the moment due to the tire-ground friction forces and represents the major spin-up moment acting on the wheel. The prime variables in this term are the airplane lift L , over which the pilot has some control during a landing maneuver, and the tire-ground friction coefficient μ , which is principally a function of tire and surface characteristics and the airplane speed.

The second term, F_{wr1} , represents the spin-up moment acting on the wheel and is due to the fluid (water, slush, etc., on the runway) drag force. This moment, which tends to produce a positive or wheel spin-up acceleration, increases with increasing fluid depth and airplane ground speed up to the onset of dynamic hydroplaning. However, the accelerations due to this moment in no way compensate for the loss in spin-up acceleration associated with reduced tire-ground friction under conditions of higher speeds and fluid depths.

The next term in the equation, $(W - L)x_c$, represents the moment which is developed when the ground reaction force $(W - L)$ does not pass through the wheel axle center line. The location of this force relative to the axle center line is a function of the tire operating mode and of the surface wetness condition. The moment $(W - L)x_c$ tends to spin up the wheel during braking on high friction surfaces as the reaction force moves behind the axle center line. However, as pointed out in reference 9, the reaction force tends to move ahead of the axle, producing a spin-down moment under all unbraked rolling conditions and under some high-speed, low friction, braked conditions.

The last term in the equation of motion, T_b , is the torque on the wheel; this torque results from either brake application or residual torque in the system.

Hydroplaning Considerations

Research has indicated that nonrotating, unbraked wheels, such as exist at airplane touchdown, will not spin up on a flooded runway surface due to dynamic hydroplaning until the airplane has decreased its ground speed to a value equal to or below a critical ground speed. That critical ground speed in knots is approximately $0.093\sqrt{p_t}$, where p_t is the tire inflation pressure measured in pascals ($7.7\sqrt{p_t}$, p_t measured in psi). Note that the wheel spin-up speed is roughly 15 percent less than the more familiar, corresponding hydroplaning spin-down speed developed empirically in reference 10. Fortunately, for full dynamic hydroplaning to occur, the runway must be covered with water or slush beyond a depth which is a function of the tire tread depth and of the surface texture, although partial hydroplaning can occur at shallower depths. Although the water or slush depth for full hydroplaning cannot be precisely defined, full-scale airplanes and NASA track tests suggest that fluid depths as low as 0.13 cm (0.05 in.) can result in tire hydroplaning when tires are worn and the runway surface is smooth. On the other hand, new tires with a full-tread groove depth operating on a textured runway require fluid depths in excess of 0.25 cm (0.1 in.) for this phenomenon to occur. In the latter case, the deep grooves in the tire tread combined with the rough surface of the runway provide interfacial water drainage in the tire-ground contact patch. It should be noted that the rear wheels of tandem wheel landing gears may require as much as 1.3 cm (0.5 in.) of

standing water or slush on the runway for dynamic hydroplaning to occur, because of the path-clearing action of the front wheels.

ANTISKID BRAKING SYSTEM OPERATING PRINCIPLES

Originally, antiskid braking systems were designed purely to prevent the deleterious effects of wheel lockups. Current systems are much more sophisticated, however, in that they are required not only to prevent the tire from skidding but also to maintain maximum braking effort under all weather conditions. Ideally, these systems are designed to operate at wheel slip ratios (the ratio of relative slip velocity between the tire and the surface to the airplane ground speed) up to and including that ratio necessary for developing the maximum available friction coefficient between the tire and the surface. To meet these design objectives, the antiskid control system must have knowledge of both the airplane ground speed and the instantaneous angular velocity of each braking wheel. Further, the system must provide a means for reducing the hydraulic pressure to a braked wheel when an excessive skid is detected and a means for reapplying the pressure when the wheel speed recovers.

Each braking wheel of the airplane is equipped with a sensor which produces a signal proportional to the angular velocity of the wheel. Most current antiskid systems depend upon these braked wheel-speed sensors to provide the information to the antiskid electronic logic circuits needed to determine both the airplane ground speed and the wheel angular velocity. However, some systems have been developed which rely upon sensors located on either unbraked nose gear wheels or on small auxiliary wheels which provide the airplane ground speed to the skid-control logic.

The hydraulic pressure applied to each landing gear wheel brake is modulated by a servo control valve according to signals from the antiskid logic system. In the early antiskid systems, these valves were of the simple "on-off" type and hydraulic pressure was either applied or released at a single rate. However, later and most current antiskid systems use constant- or variable-gain servo control valves to modulate the application of brake pressure in order to obtain the desired wheel motion control.

ANTISKID BRAKING SYSTEM LOGIC

The primary logic circuit in an antiskid system provides individual wheel brake control to maintain maximum braking effort with minimum tire slippage. Most antiskid systems also provide additional logic circuits for touchdown protection to guard against landing with brakes applied and for differential locked-wheel protection and to serve as a

backup to the brake control circuit. These circuits are described in some detail and are analyzed in terms of their behavior under adverse weather conditions in the following paragraphs.

Brake Control

General description.- The primary function of the antiskid system is to control the braking effort by constantly readjusting the brake pressure so as to maintain a brake torque sufficient to balance the maximum friction force available between the tire and the runway. Better and more efficient brake control has been the object of engineering development since antiskid systems were first introduced. In the earlier systems, the antiskid logic circuits monitored the rate of change in the wheel angular velocity by means of a braked wheel-speed sensor as hydraulic pressure was applied to the wheel brake. When the tire-to-ground adhesion limit was exceeded, the wheel began to skid and rapidly decelerated toward a locked-wheel condition. However, upon reaching or surpassing a preset wheel angular acceleration (velocity rate threshold), the antiskid system generated an electrical signal that commanded the servo control valve to reduce hydraulic brake pressure to zero. Once the pressure was relieved, the wheel was free to spin up, provided that the tire/runway friction torque exceeded any residual brake drag and bearing friction torques. The full brake pressure was then reapplied and the cycle was repeated when another skid was entered.

Later antiskid systems modulated the reapplication of brake pressure following entry into a skid. In these systems, the hydraulic pressure was modulated on the basis of the depth of the previous wheel skid; that is, the rate of change of the angular velocity of the wheel was compared with the velocity rate threshold, and the difference in the two rates determined the magnitude of the command signal to the servo control valve to relieve brake pressure. Whereas earlier antiskid systems of this type employed a fixed velocity rate threshold, later versions employed variable rate thresholds in an effort to improve braking efficiency. In these latter systems, the velocity rate threshold was constantly changing and the magnitude of the command signal at any instant was determined by the previous behavior of the braked wheels and, as such, was dependent upon the available runway traction. The general operating principle of such a system is as follows: an initial reference rate is set and when it is exceeded, the brake pressure is reduced in proportion to the error signal. The error signal is then stored. When the next skid commences, the brake pressure is automatically reduced and the velocity rate threshold is changed in proportion to the difference between the present error signal and the stored error signal. With additional skid signals, the pressure is reduced to a stabilized level that, in theory, provides the maximum available deceleration.

The latest antiskid systems have departed from the use of velocity rate thresholds as governing parameters. Instead, these systems rely upon either slip velocity or slip ratio, either of which requires a knowledge of both the airplane ground speed reference and the braked wheel speed. For example, one of the latest systems tries to maintain a slip velocity of approximately 3 m/sec (10 ft/sec). During braking, the skid-control logic continuously compares the instantaneous wheel angular velocity with the reference ground speed as determined from a braked wheel-speed sensor. When the braked wheel slip velocity exceeds the 3 m/sec (10 ft/sec) threshold, a signal is generated to the servo control valve to reduce brake pressure, allowing the wheel to spin up. When the wheel speed approaches or equals the reference ground speed, a signal is transmitted to the servo control valve to increase brake pressure; this pressure generates another wheel skid and the process is repeated. Another antiskid system tries to maintain a preselected or calculated slip ratio by continuously comparing the instantaneous wheel angular velocity with the airplane ground speed as determined from a nose wheel sensor. In this model, brake pressure is relieved when the braked wheel slip ratio exceeds the command value and is reapplied when the wheel speed approaches the reference ground speed. Note that, as opposed to the later systems, most early antiskid systems did not require a reference speed or an actual measure of the braked wheel speed in their skid detection logic. Instead, the information provided by the braked wheel-speed sensor was used only to determine wheel deceleration levels. However, most of the advanced antiskid systems still retain the adaptive pressure modulation feature of the early systems; that is, the level of applied brake pressure is a function of the runway traction as detected in the previous skid.

Behavior in adverse weather.- The effectiveness of antiskid brake control can be lost or, at least, severely reduced if the friction generated between the tire and the runway is sufficiently poor so as to produce low wheel spin-up accelerations following brake release. Such low friction levels are generally associated with adverse weather operations and high airplane ground speeds. In addition to high-speed, low friction conditions, certain pilot inputs can also adversely affect brake control. These inputs generally consist of either early brake application at touchdown wherein the brakes are applied before the wheels are fully spun up, or rapid (hard) braking after spin-up. Neither of these situations constitutes normal or routine braking situations; however, the potential for their occurrence does exist as the result of extended touchdown points, excessive landing velocities, equipment malfunctions, or other similar conditions. In the case of early brake application, the skid-control logic fails to obtain an accurate airplane ground speed reference; in the case of rapid brake application, the logic system fails to retain an accurate airplane ground speed reference. Both of these cases are discussed in more detail in the following paragraphs with the aid of data obtained from flight tests conducted with different airplanes employing different antiskid braking systems.

Figure 2 illustrates the antiskid brake control response of the wheels on a four-wheel bogie of a large jet transport to brake applications that took place prior to and after full wheel spin-up during a landing on a runway wetted to an average water depth of approximately 0.06 cm (0.024 in.). (See ref. 7.) Time histories of the angular velocity of the four wheels during and following brake application which occurred prior to wheel spin-up are presented in figure 2(a). Based upon the wheel-speed information that was received up until the time the brakes were applied, it is apparent that the airplane ground speed assumed by the skid-control logic circuits for the two front wheels immediately following brake application is considerably below the actual speed of the airplane. The low wheel spin-up accelerations following brake release during each braking cycle prevented the two front wheels from attaining synchronous speed (equivalent vehicle ground speed) until approximately 30 sec after touchdown. By that time, the airplane had slowed to the point where the friction between the tires and the pavement had increased sufficiently so as to produce overpowering wheel spin-up accelerations; thus, the wheels are caused to exceed the assumed low ground speed reference and to acquire a higher one. Figure 2(a) shows that, after several cycles of such behavior, the skid-control logic finally acquired the proper ground speed reference. At that point satisfactory control of braked wheel motion was established and maintained down to a stop.

The benefit path clearing provided by tandem wheels is also illustrated by the data of figure 2(a). The data obtained from the antiskid logic circuits clearly indicate that the rear tandem wheels recover synchronous speed at a much faster rate than the front tandem wheels. The higher wheel spin-up rates associated with the rear wheels suggest that they develop better traction than the front wheels of the landing gear. The leading wheel in a tandem gear removes the bulk water and tends to penetrate any thin fluid film on the pavement; thus, a less slippery surface is presented to the trailing wheel.

The curves of figure 2(b) suggest that the pilot should delay brake application during landings on a wet runway to allow more time for the wheels to fully spin up at touchdown; this delay allows the antiskid system to commence operating in its most efficient mode. By providing the skid-control logic system with an accurate ground speed reference to diminish the relative slip between the tire and the surface, cornering capability is improved and tire wear is reduced. In figure 2(a), the data gathered when brakes were applied early indicate that all tires experienced considerable skidding, particularly the front tires that were subjected to deep skids for approximately 30 sec. The skidding also degraded the stopping performance of the airplane, although this is not evident from a comparison of the data from the test runs described in figure 2. Relative braking effectiveness is not evident from the figures because the two test runs were made at different airplane gross weights and different brake application speeds.

Figure 3 illustrates brake control loss on a low friction surface due to rapid brake application after full wheel spin-up. This figure is a reproduction of an oscillograph record obtained during flight tests of an airplane equipped with a dual wheel main landing gear in the Joint FAA/USAF/NASA Runway Research program described in reference 1. For this test, the airplane first touched down on a dry surface to assure full spin-up of all wheels and then traversed a section of the runway that had been wetted by water trucks. Following entry into the wet section, the pilot called for immediate maximum braking. The outputs from sensors which monitored the applied brake pressure and the angular velocity of each of the four wheels over a time period extending for roughly 7 sec after braking was initiated are presented in figure 3. The figure shows that the time histories of both the brake pressure and the wheel angular velocity of the outboard wheels (wheels 1 and 4) were approximately the same shape and magnitude; both wheels locked up after only three brake pressure cycles. From the figure, it is apparent that the antiskid control for these two wheels dropped out at about 2.6 sec, allowing full-system pressure application to the wheel brakes and thus preventing any possibility of wheel spin-up. This loss of brake control is typical for velocity-rate dependent, skid-detection logic circuits that do not require or even use a ground speed reference. Newer antiskid systems supplied with an accurate ground speed reference would not have experienced this loss of brake control. The skid-control logic system for these two wheels assumed that the airplane was simply rapidly decelerating on the runway rather than decelerating at a rate defined by the slope of the dashed line noted on all four wheel angular velocity traces. (See fig. 3.)

The test results presented in figure 3 show that the right inboard wheel (wheel 3) was the only wheel on the main gear of the airplane over which the antiskid system exhibited optimum control. The left inboard wheel (wheel 2) was allowed to overbrake and to enter into deep skids. As was true for the outboard wheels (wheels 1 and 4), the behavior of wheel 2 resulted from the fact that the antiskid logic could not estimate the wheel synchronous speed and therefore allowed hydraulic pressure to be applied before wheel synchronous speed was achieved. The fact that wheel 2 did not lock up as did the two outboard wheels (wheels 1 and 4) is attributed to the locked-wheel protection circuitry that is discussed in a subsequent section.

Figure 3 also illustrates how a runway crown can affect the performance of antiskid braking systems on airplanes which have gears with wheels mounted side by side as is true for dual and dual-tandem wheel arrangements. Due to the presence of the crown, more of the vertical load supported by each gear is carried by the inboard wheels than by the outboard wheels. Thus, for any slippery conditions on a runway, the spin-up torque, and hence the spin-up acceleration, associated with the inboard wheels will be greater than that of the outboard wheels. A comparison of the inboard and outboard wheel responses that are presented in figure 3 does illustrate significant differences in brake control; these

differences can be attributed to the runway crown. Both lighter loaded outboard wheels (wheels 1 and 4) rapidly spun down to a locked-wheel skid, but the logic circuits for the inboard wheels (wheels 2 and 3) maintained skid control, although wheel 2 did encounter some deep skids.

Figure 4 presents the angular velocities of the outboard wheels on a four-wheel bogie of an airplane equipped with an early antiskid design. These angular velocities were recorded during heavy braking on flooded grooved and ungrooved surfaces. The longitudinal deceleration of the airplane is also presented in order to provide some measure of the overall braking effort. The purpose of this figure, which was taken from reference 5, is to illustrate the effects of tire tread and surface texture on antiskid braking response. As was done in the previous example, the airplane entered the wet section of the runway following full wheel spin-up on a dry surface. Figure 4(a) presents data from smooth-tread tires, whereas figure 4(b) presents data from relatively new, rib-tread tires equipped with five grooves. In both tests, the airplane traversed first the grooved and then the ungrooved runway test section. Figure 4(a) shows that the leading wheel rapidly spun down as a result of braking action. The 105-knot airplane ground speed at entry into the test section is well above the hydroplaning speed for this tire ($p_t = 758 \text{ kPa (110 psi)}$); hence, the wheel spin-up acceleration following any brake release is too low to permit the wheel to reacquire synchronous speed. Actually, the tire is in a hydroplaning mode as it leaves the grooved section and it remains in that mode over the entire length of the ungrooved section. The benefits of path clearing are clearly illustrated in this figure by comparing the angular velocities of the leading and trailing wheels. The depth of water traversed by the rear tire is apparently less than that encountered by the front tire since the rear tire is not hydroplaning on the grooved section. The good skid control that was noted while the trailing tire was negotiating the grooved section, however, is not apparent on the ungrooved section because the antiskid system permits the wheel to "ratchet" down to a locked wheel. Thus, two aids to better antiskid operation, runway grooving and wheel path clearing, both of which tend to improve tire traction in adverse weather, are depicted here.

Figure 4(b) illustrates how the addition of a tread pattern to the tire (in this case, five circumferential grooves) improves traction in wet conditions and hence improves the performance of the antiskid system. The figure shows that the skid control associated with both the leading and trailing wheels appeared to be adequate on the flooded grooved surface although, without benefit of path clearing, the leading wheel did experience deeper skids than the trailing wheel. Control on the flooded ungrooved surface, however, was not as adequate as on the flooded grooved surface although no locked-wheel skids were evident. In this test, it was estimated that the airplane ground speed went below the hydroplaning spin-up speed of 81 knots at approximately 2 sec, if an average airplane deceleration of 0.2g is assumed up to that time. The change in frequency of the angular velocity trace

for the leading wheel, which occurred at roughly 2 sec, seems to verify this estimate. Although the wheel is operating at below hydroplaning speed beyond that point, the ungrooved surface is still sufficiently slippery to retard wheel spin-up accelerations and thus to hinder antiskid performance.

To remedy the partial or complete loss of brake control in present antiskid systems, the pilot must release the brakes, allow the wheels to spin up to the airplane synchronous speed, and then recycle the braking effort. This action is necessary whether loss of brake control is attributed to brake application prior to or subsequent to full wheel spin-up. It would appear from the data presented here that brake control problems could be avoided with new antiskid systems by providing their logic circuits with an accurate reference ground speed that can be continuously related to the speed of each braked wheel. Brake control problems with both current and future antiskid systems essentially could be avoided if sufficient traction existed between the tire and the runway to provide rapid wheel spin-up following brake release. Good traction is generally available under dry runway conditions, but in adverse weather the keys to good traction include rib-tread tires and a runway surface which provides good drainage. (Good runway drainage can be obtained by grooving or by applying a porous overlay.)

Touchdown Protection

General description.- Most antiskid systems are provided with a touchdown protection circuit to prevent hydraulic pressure from being applied during the touchdown phase of a landing should the pilot inadvertently apply brakes. This circuit is generally deactivated by squat switches on each landing gear, by the wheels spinning up to or exceeding a predetermined angular velocity, or by a combination of the two. Upon deactivation, normal skid-control braking is available.

In some touchdown protection circuits, an artificial ground speed is supplied while the airplane is in the air and once the main gear squat switches have been energized, protection is then provided until this speed has decayed to zero at a predetermined rate. In other circuits, touchdown protection is provided for a preset time period following squat switch engagement. The protection in both types of circuits may extend over a time period as long as 7 sec. During this time, no hydraulic pressure can be applied to the brake by pilot action until the wheel has spun up to or beyond a preset threshold angular velocity, typically equivalent to 25 to 50 knots ground speed. However, if the wheel has not spun up to the threshold velocity by the end of the time period, the antiskid system is not activated and the pilot is in a manual braking mode. The purpose of this portion of the circuitry is to allow the brakes to be applied (albeit manually) in the event of a faulty wheel sensor.

Behavior in adverse weather.- Experience has shown that touchdown protection can be lost under certain adverse weather and landing conditions. The primary cause of this

loss is delayed wheel spin-up. Delayed wheel spin-up can result from either landing on a flooded runway when the touchdown speed is in excess of the tire dynamic hydroplaning speed or from landing on a low traction runway under low tire loading which would result, for example, from a delayed spoiler deployment.

Figure 5 illustrates a prolonged spin-up of an unbraked wheel during touchdown on a flooded test surface with an average water depth of 0.5 cm (0.2 in.) at the Langley aircraft landing loads and traction facility. Touchdown occurs when vertical load is first applied to the tire. The figure indicates that the tire was essentially fully loaded at 80 kN (18 000 lb) approximately 1 sec after initial touchdown; however, the wheel did not spin up to full vehicle (carriage) speed until approximately 5 sec later. Although the wheel did attempt to spin up $2\frac{1}{2}$ sec after touchdown, perhaps due to shallow water conditions in a runway section, the wheel speed never actually approached synchronous speed until the carriage had slowed to approximately 90 knots. It is interesting to note that with the tire test inflation pressure of 965 kPa (140 psi), the calculated wheel spin-up speed was 91.1 knots. The significance of figure 5 is that, for those airplanes whose touchdown protection schemes incorporate delay periods of less than about 5 sec, the antiskid system would not have been activated and the pilot would have been in a manual braking mode following that period.

The test described in figure 6 was similar to the test described in figure 5, but with brake application approximately $2\frac{1}{2}$ sec after touchdown. Since the carriage speed remained above the tire hydroplaning spin-up speed throughout the initial $2\frac{1}{2}$ sec, the tire did not spin up. Obviously, if the touchdown protection delay period had been within that time frame, the antiskid system would not have been activated and brake pressure would have been applied to the wheel. Although the wheel locked up, no skid signal was generated because the antiskid system detected no wheel speed and therefore had no indication of any carriage speed; hence, it assumed that the vehicle was parked and it resorted to manual braking. Thus, if the pilot had landed with brakes fully applied, the touchdown protection circuit would have prevented any hydraulic pressure from being transmitted to the brakes until some threshold, such as wheel angular velocity or some time duration had been reached. When that threshold or time period was reached, touchdown protection would have ceased and the antiskid braking system may or may not have been activated, depending upon the wheel angular velocity. If it had not been activated, the airplane would have been in a manual braking mode and the extent of braking would have been a function of the pilot's brake pedal depression.

In present antiskid systems, the remedy to this touchdown protection problem is for the pilot to release brakes, to allow the wheel to spin up to the airplane synchronous speed, and then to recycle the braking action. In the test described in figure 6, the brakes were released at 6 sec; since the vehicle speed was under 91 knots, the wheel immediately spun

up to the carriage synchronous speed. Although it is not shown here, the application of brakes beyond that point resulted in good antiskid control. The information provided suggests that the loss of touchdown protection could be avoided in new antiskid systems by providing the logic circuit for those systems with as accurate a reference ground speed as could be obtained from, for example, an onboard navigational aid system. With an accurate knowledge of the ground speed, the logic circuit for touchdown protection could determine when antiskid protection is needed and when the airplane is parked. Of course, all current touchdown protection schemes would be satisfactory if the runway surface offered sufficient traction to avoid prolonged wheel spin-ups.

Locked-Wheel Protection

General description.- Locked-wheel protection circuits are provided in antiskid logic systems to guard against a dragging brake or an otherwise abnormally slow wheel recovery from a deep braking skid. These circuits prevent hydraulic pressure from being applied to the slow wheel until it has recovered to a speed determined by the logic system. In essence, the locked-wheel protection circuit is a backup to the skid-control circuit. On some aircraft, the rotational speed of all wheels is incorporated under a single locked-wheel protection circuit; however, most antiskid systems provide this protection by either pairing two wheels or combining wheels from opposite sides of the airplane in separate circuits. For example, the front outboard wheels of the left and right main landing gears may be paired together. In this and other like pairs, the two wheel speeds are continuously compared and, whenever the speed of one wheel is below a preselected value of its compared mate, the brake of that wheel is released to permit the slow wheel to spin up.

Behavior in adverse weather.- To be completely fail-safe, the speed of the slow wheel should be compared with the airplane synchronous speed since all the wheels on a given circuit may be either slow or slowing down at a faster rate than the airplane is decelerating. When all wheels on a circuit decelerate too rapidly, the system logic may fail to recognize an impending locked-wheel condition. Few airplanes are equipped with locked-wheel protection circuits which rely upon sources other than braked wheels to provide a measure of the airplane ground speed. Thus, the pairing or combining of wheels to take advantage of both the path-clearing benefits available with gears having tandem wheels and the differential wheel loadings on crowned runways becomes significant. For example, the test airplane used to obtain the data presented in figure 2 was equipped with a main gear which consisted of two four-wheel bogies that depended upon two locked-wheel protection circuits, as illustrated by the dashed lines in sketch (a): All inboard wheels were on one circuit and all outboard wheels were on the other. The benefits of path clearing in minimizing tire skids on wet runways have

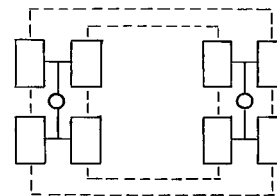

Sketch (a)

already been pointed out by using figure 2; however, were it not for the "dialogue" between the front and rear wheels in each locked-wheel protection circuit, the front wheels in this test would have most assuredly locked up because of their deep skids and slow spin-up accelerations.

Ineffective wheel pairing for locked-wheel protection is illustrated in figure 3 where the inboard and outboard wheels are again on separate circuits, only in this case the airplane is equipped with a dual wheel gear and the benefits of path clearing cannot be realized. As pointed out in the earlier discussion of this figure, the wheel loading which results when the airplane lands on or near the center line of a crowned runway subjects the inboard wheels to higher spin-up accelerations than the outboard wheels. The low traction conditions associated with this test forced both of the lighter loaded outboard wheels to lose brake control and rapidly spin down at essentially the same rate, although this rate is higher than that of the airplane. Since the two outboard wheels together comprised one locked-wheel protection circuit and there was no other source of airplane ground speed information for comparison purposes, protection was lost and both wheels locked up. Figure 3 does show, however, that a pairing of the inboard wheels appeared to have prevented lockup of the number 2 wheel which, for some reason, lost brake control logic. It is interesting to note that the runway used in the test described in figure 2 was a tilted slab with no center-line crown; hence, the loading and braked behavior of the corresponding inboard and outboard wheels were essentially the same.

To summarize, loss of locked-wheel protection can occur under adverse weather conditions as the result of both poor tire traction, which causes a loss of brake control and permits large wheel motion excursions, and ineffective wheel pairing. The effect of this loss is that paired wheels decelerate to a locked-wheel condition because, although they are both decelerating at the same rate, they are decelerating at a rate higher than that of the airplane. For present systems, the remedy for this loss is the same as that for loss of brake control; that is, to release brakes to allow the wheels to spin up to synchronous speed and then to recycle. However, present systems can be revised for safer operations by optimizing wheel pairings to account for differential wheel loadings and path-clearing benefits and by providing the logic system with an alternate ground speed reference.

BRAKING CONSIDERATIONS DURING CROSS-WIND OPERATIONS

The effects of cross winds on airplane braking and directional control performance under adverse weather conditions are not well defined because it is difficult to acquire quantitative test data. Safety considerations of the airplane and crew, as well as the unpredictability of surface winds, preclude full-scale flight testing to fully explore the limits of airplane cross-wind performance under slippery runway conditions. However,

data obtained from a single braked wheel over a range of yaw (steering) angles during track test programs can shed some light on airplane behavior under antiskid control during cross-wind operations. For example, the data of figure 7, which were generated during the program described in reference 11, show the variation of drag- and side-force friction coefficients with slip ratio during a single brake cycle from free rolling to wheel lockup. The test was performed for a 20×4.4 airplane tire at nominal yaw angles of 0° , 5° , and 16° . Data are included for a dry surface (fig. 7(a)) and a wet surface (fig. 7(b)), both at a nominal ground speed of 100 knots. The figure shows that, regardless of the surface condition, the maximum available cornering capability occurs when there is no braking (Slip ratio = 0) and that there is a rapid decrease in cornering capability with increasing brake effort (increasing slip ratio) until all cornering is lost at or before wheel lockup (Slip ratio = 1.0). On the other hand, the figure shows that a certain amount of wheel slip is required to develop a measurable braking force.

Similar braking and cornering characteristics were observed during track tests of tires undergoing the cyclic braking of antiskid control. As an example, figure 8 presents the time history of the brake pressure recorded during a 75-knot test of a tire with anti-skid protection operating on a dry surface at a yaw angle of 6° with corresponding drag- and side-force friction coefficients as related to the wheel slip ratio. Two sets of friction coefficients are presented: one includes the data from all brake cycles during the test and the other describes the variation of the coefficients with slip ratio during a selected brake cycle. A comparison of the curves of this figure with those of figure 7(a) does suggest that tire frictional behavior under antiskid control can be approximated by its behavior during single cycle braking tests.

In adverse weather, the friction levels for both drag and cornering become quite low as shown by the wet surface condition of figure 7(b) and by the cyclic braking data under a flooded condition in figure 9. Of perhaps more importance from the standpoint of antiskid operation is the fact that the slip ratio for maximum drag (braking) on a slippery surface is generally higher and not as clearly defined as on a dry surface. As a result, skid-control systems which rely upon velocity-rate detection logic tend to maximize braking at the expense of cornering on a slippery surface. The skid-control systems that use either slip velocity or slip ratio detection logic generally tend to maximize cornering at the expense of braking on such surfaces. Thus, under low traction conditions, particularly at high speeds where tire hydroplaning effects are more pronounced, most current skid-control systems tend to either underbrake or overbrake the wheel.

Examples of antiskid control at low and high slip ratios (underbraked and overbraked conditions, respectively) are given in figure 10. This figure presents typical time histories of airplane main gear wheel behavior under antiskid-controlled braking at high speeds on slippery surfaces. These time histories are traces of actual oscillograph

records obtained during flight tests of a two-engine and a three-engine jet transport in the Joint FAA/USAF/NASA Runway Research program described in reference 1. The low wheel slip ratio operation of a two-engine jet transport illustrated in figure 10(a) results in extensive periods of no braking, thereby preserving tire cornering capability for directional control purposes in the presence of a cross wind, but reducing the airplane stopping performance. For the high wheel slip ratio operation of a three-engine jet transport (fig. 10(b)), the wheel spends much of the time (at least during the time period shown) in a deep skid, thereby almost totally destroying its cornering capability. The overall braking effectiveness in this example is also undoubtedly diminished in view of the wide range of slip ratios apparent from a comparison of the airplane ground speed (wheel synchronous speed) and the instrumented wheel speed. Thus, antiskid system design necessitates trade-offs between tire braking and cornering capabilities.

Both good braking and cornering are provided at low wheel slip ratios when the runway friction level is high, as exemplified by figures 7(a) and 8. Hence, one means of avoiding potential braking and/or steering problems in adverse weather, including the presence of cross winds, is to provide surfaces with adequate texture so that tire traction losses during wet runway operations are minimal.

CONCLUDING REMARKS

The behavior of current antiskid braking systems operating under adverse weather conditions has been analyzed. This analysis, which considered brake control and both touchdown and locked-wheel protection, indicated that the operational performance of these systems is highly dependent upon wheel spin-up acceleration and can be adversely affected by certain pilot braking inputs when these accelerations are low. Normal antiskid performance is assured if the tire-to-runway traction is sufficient to provide high wheel spin-up accelerations or if the system is provided a continuous, accurate ground speed reference. Most current antiskid systems, however, rely upon braked wheel-speed sensors alone to acquire information on both wheel-skid detection and airplane speed. Under certain landing conditions, this dependence upon braked wheel sensors can lead to anomalous antiskid performance such as wheel speeds that are far below the airplane ground speed or locked-wheel skids that are accompanied by a partial or complete loss of cornering and a much decreased braking capability. Anomalous performance generally occurs under landing conditions where adverse weather and airplane speed on the runway combine to produce low to nil ground traction (low to nil wheel spin-up accelerations) and where wheel braking by the pilot is applied either before full wheel spin-up following touchdown or too hard after full wheel spin-up. This anomalous antiskid operation can be avoided largely by proper adjustments in the pilot braking technique and by optimizing wheel pairings in the locked-wheel protection circuit to account for differential wheel loadings

and path-clearing benefits. The design of antiskid systems is complicated by the necessity for trade-offs between the tire braking and cornering capabilities, both of which are necessary to provide safe operations in the presence of cross winds, particularly under slippery runway conditions.

Langley Research Center
National Aeronautics and Space Administration
Hampton, Va. 23665
May 24, 1976

REFERENCES

1. Merritt, Leslie R.: Impact of Runway Traction on Possible Approaches to Certification and Operation of Jet Transport Aircraft. Paper 740497, Soc. Automot. Eng., Apr.-May 1974.
2. Horne, Walter B.; Yager, Thomas J.; and Taylor, Glenn R.: Review of Causes and Alleviation of Low Tire Traction on Wet Runways. NASA TN D-4406, 1968.
3. McCarty, John L.; and Leland, T. J. W.: Recent Studies of Tire Braking Performance. Tire Sci. & Technol., vol. 1, no. 2, May 1973, pp. 121-137.
4. Pavement Grooving and Traction Studies. NASA SP-5073, 1969.
5. Yager, Thomas J.; Phillips, W. Pelham; Horne, Walter B.; and Sparks, Howard C. (appendix D by R. W. Sugg): A Comparison of Aircraft and Ground Vehicle Stopping Performance on Dry, Wet, Flooded, Slush-, Snow-, and Ice-Covered Runways. NASA TN D-6098, 1970.
6. Model 737 Data - FAA Evaluation of Proposed Landing Certification Rules. Doc. No. D6-43078, Boeing Co., Dec. 1973.
7. Model L-1011 (Base Aircraft) Landing Performance Report for FAA Evaluation of Concorde SST Special Condition 25-43-EU-12. Rep. No. LR 26267, Lockheed Aircraft Corp., Jan. 14, 1974.
8. Merritt, Leslie R.: Concorde Landing Requirement Evaluation Tests. Rep. No. FAA-FS-160-74-2, 1974.
9. Horne, Walter B.; and Leland, Trafford J. W.: Influence of Tire Tread Pattern and Runway Surface Condition on Braking Friction and Rolling Resistance of a Modern Aircraft Tire. NASA TN D-1376, 1962.
10. Horne, Walter B.; and Dreher, Robert C.: Phenomena of Pneumatic Tire Hydroplaning. NASA TN D-2056, 1963.
11. Dreher, Robert C.; and Yager, Thomas J.: Friction Characteristics of 20×4.4 , Type VII, Aircraft Tires Constructed With Different Tread Rubber Compounds. NASA TN D-8252, 1976.

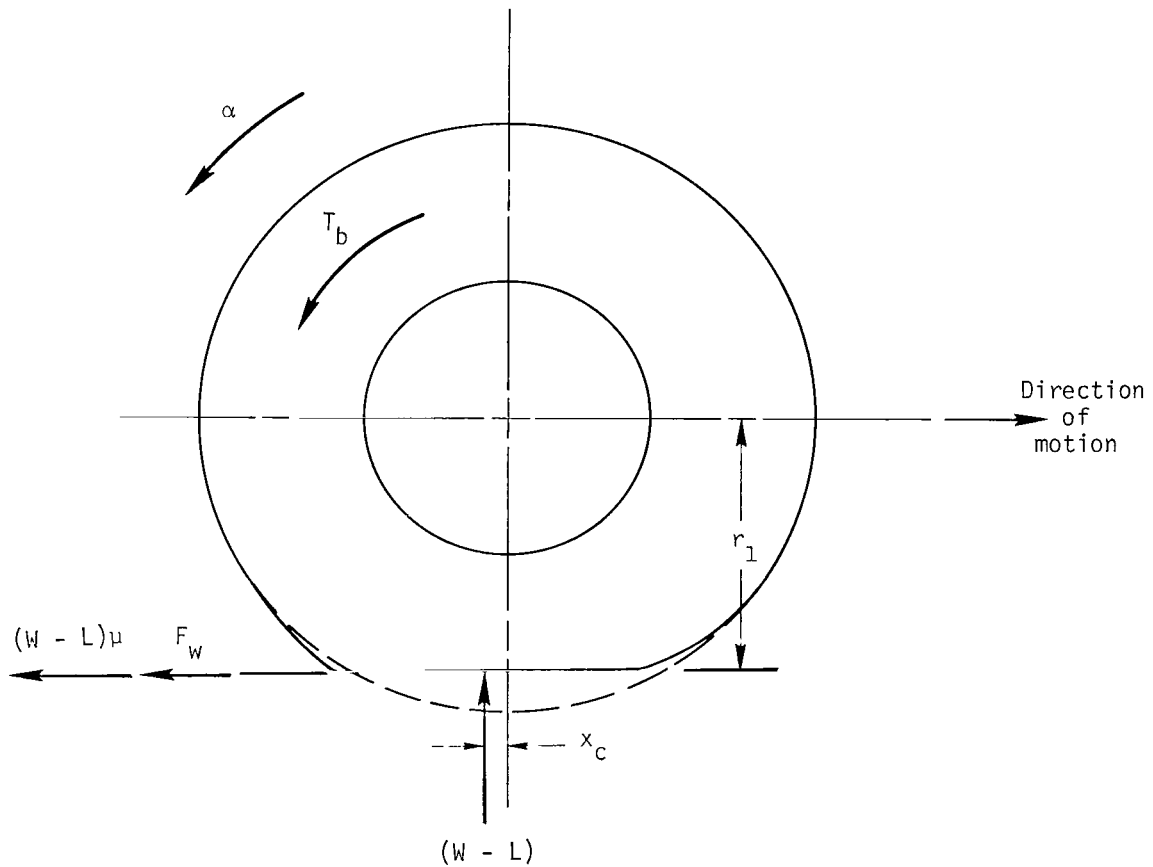
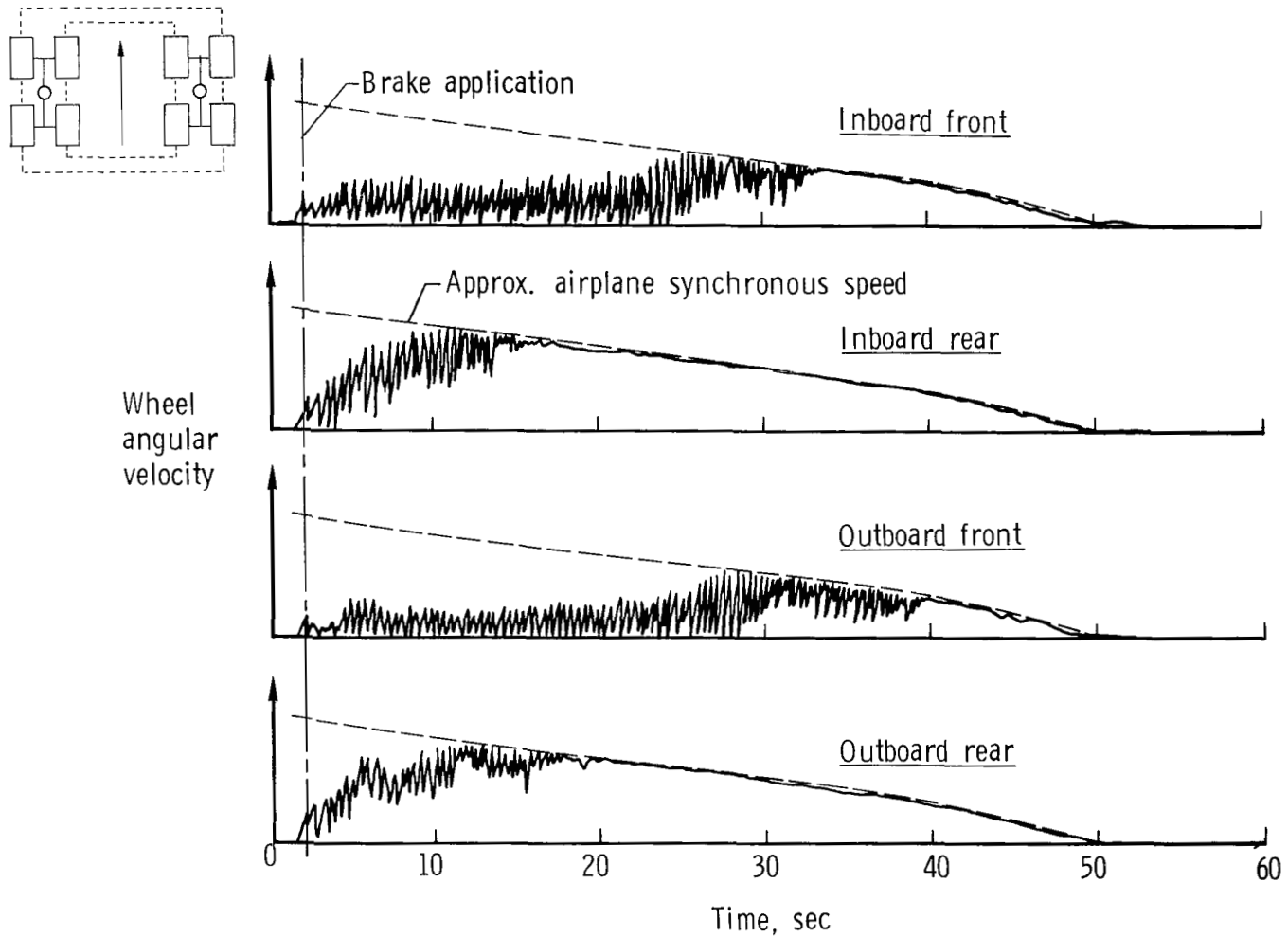
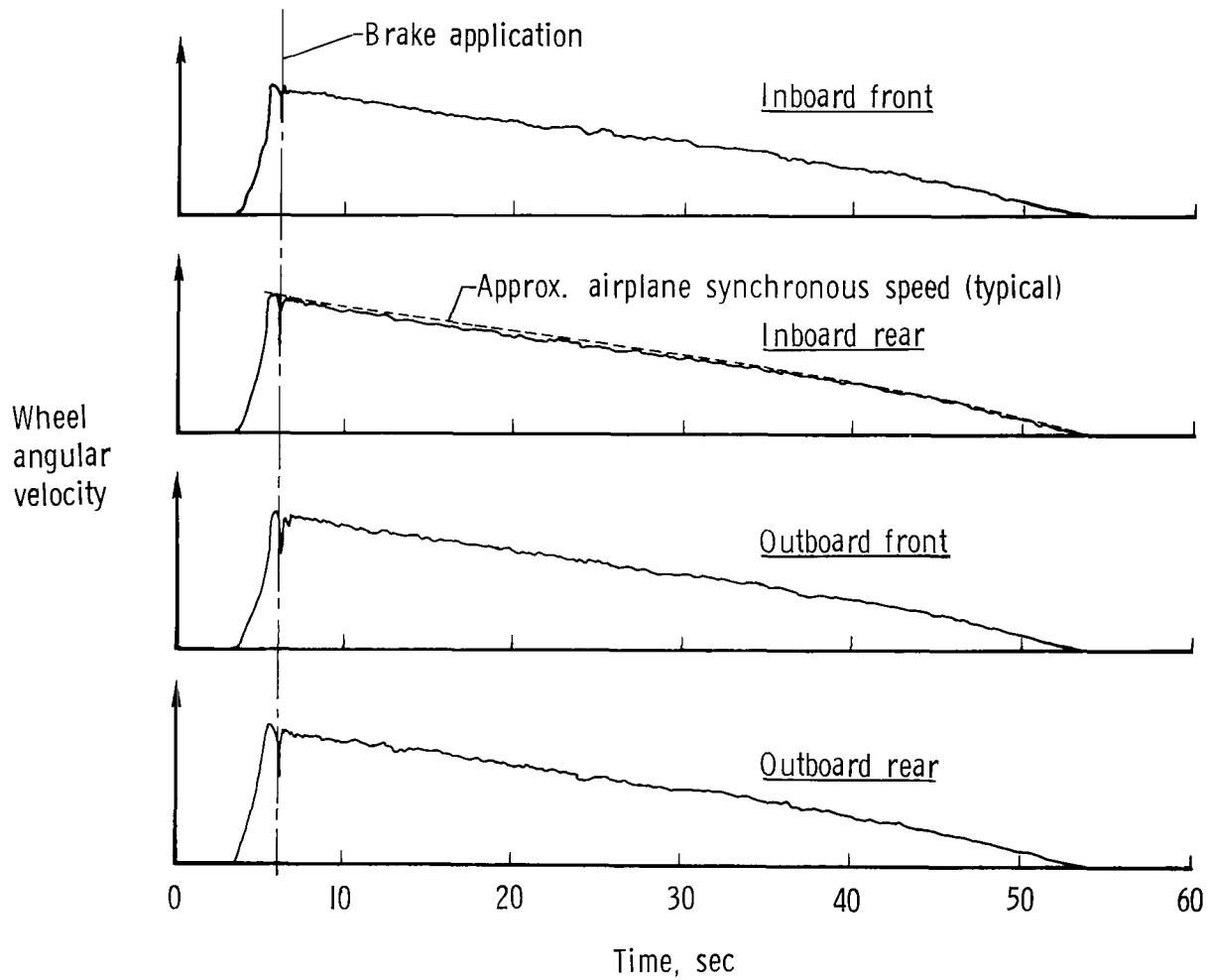

Figure 1.- Forces and moments acting on airplane wheel under braked rolling conditions.



(a) Brake application prior to full wheel spin-up.

Figure 2.- Wheel-speed time histories of angular velocity of four-wheel bogie showing antiskid brake control response to brake application prior to and after full wheel spin-up during landing on wet surface. Average water depth, 0.06 cm (0.024 in.). (See ref. 7.)



(b) Brake application after full wheel spin-up.

Figure 2.- Concluded.

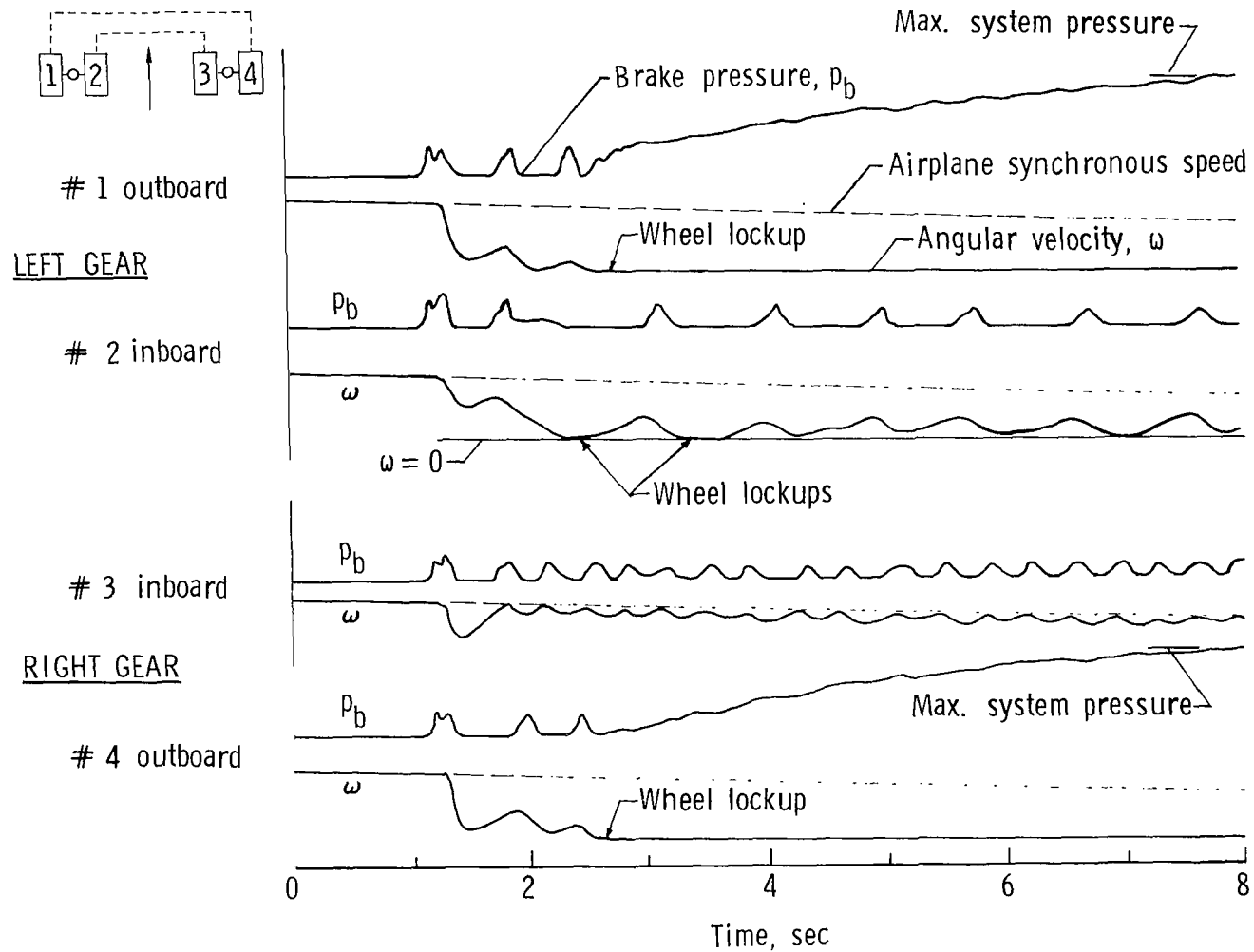
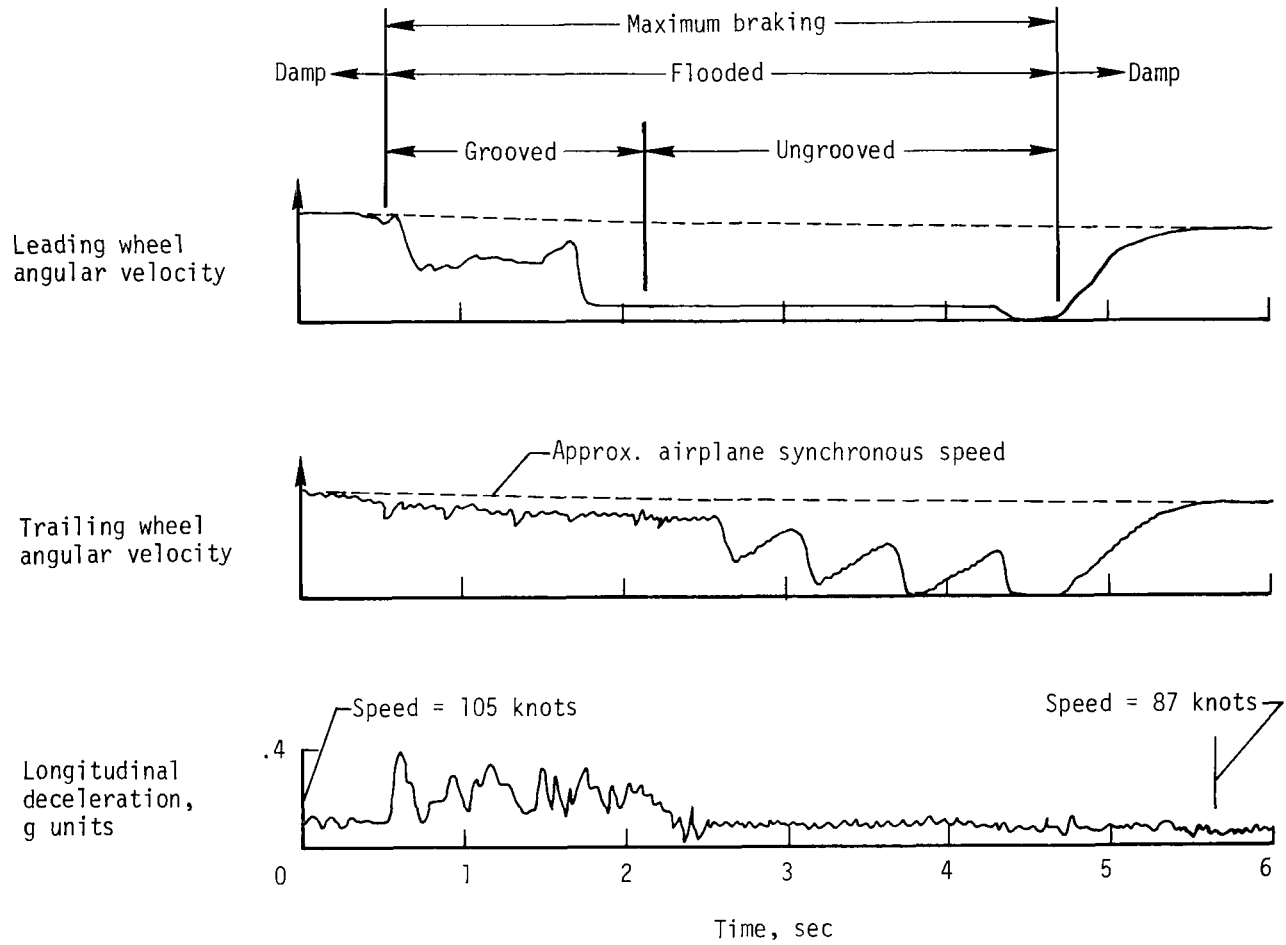
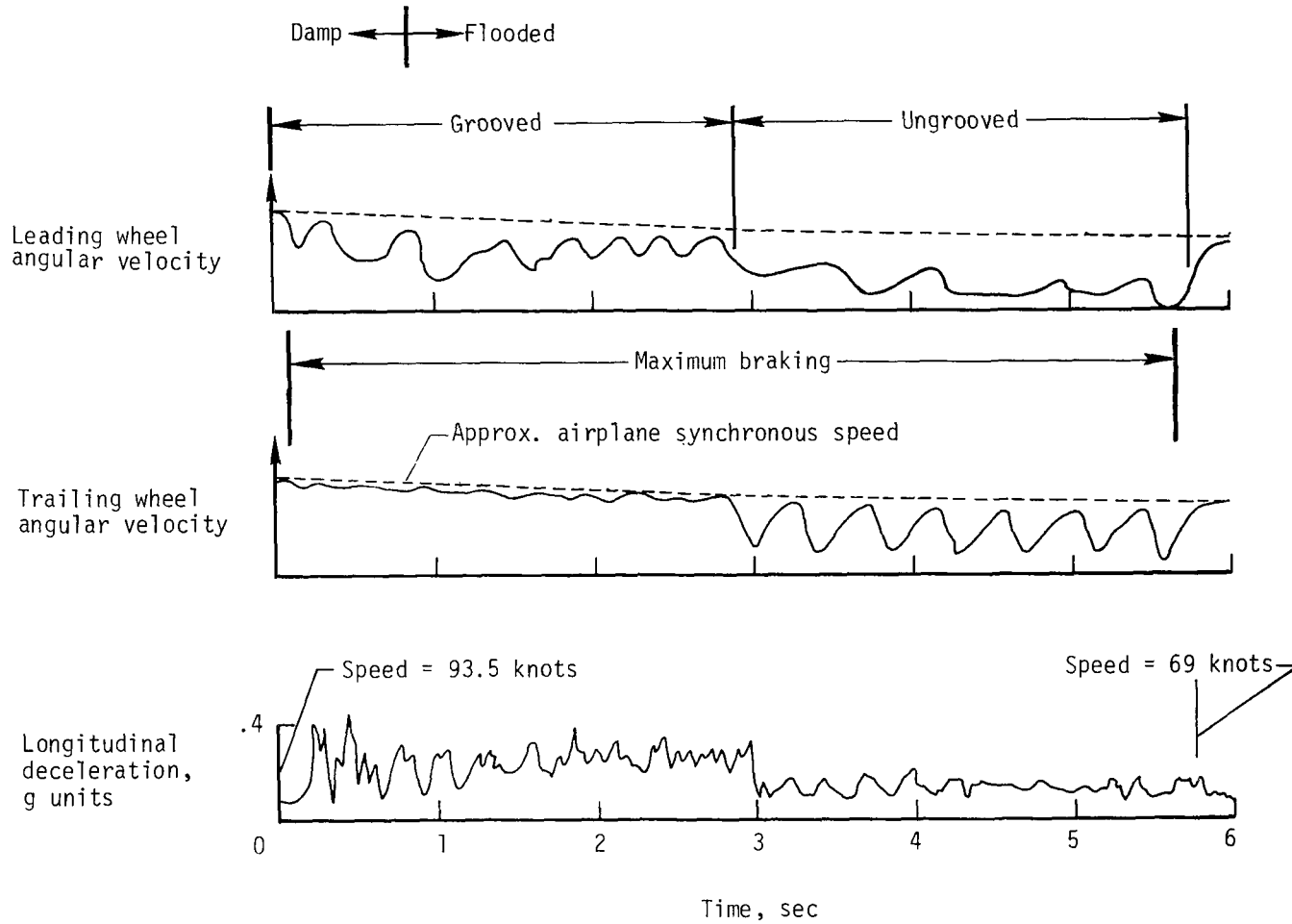

Figure 3.- Wheel and brake time histories from wet runway braking tests of airplane equipped with dual wheel gear. Average water depth, 0.1 cm (0.04 in.).



(a) Smooth-tread tires.

Figure 4.- Braking behavior of smooth- and rib-tread tires on outboard wheels of four-wheel bogie gear while traversing flooded grooved and ungrooved surfaces (ref. 5).



(b) Rib-tread tires (five grooves).

Figure 4.- Concluded.

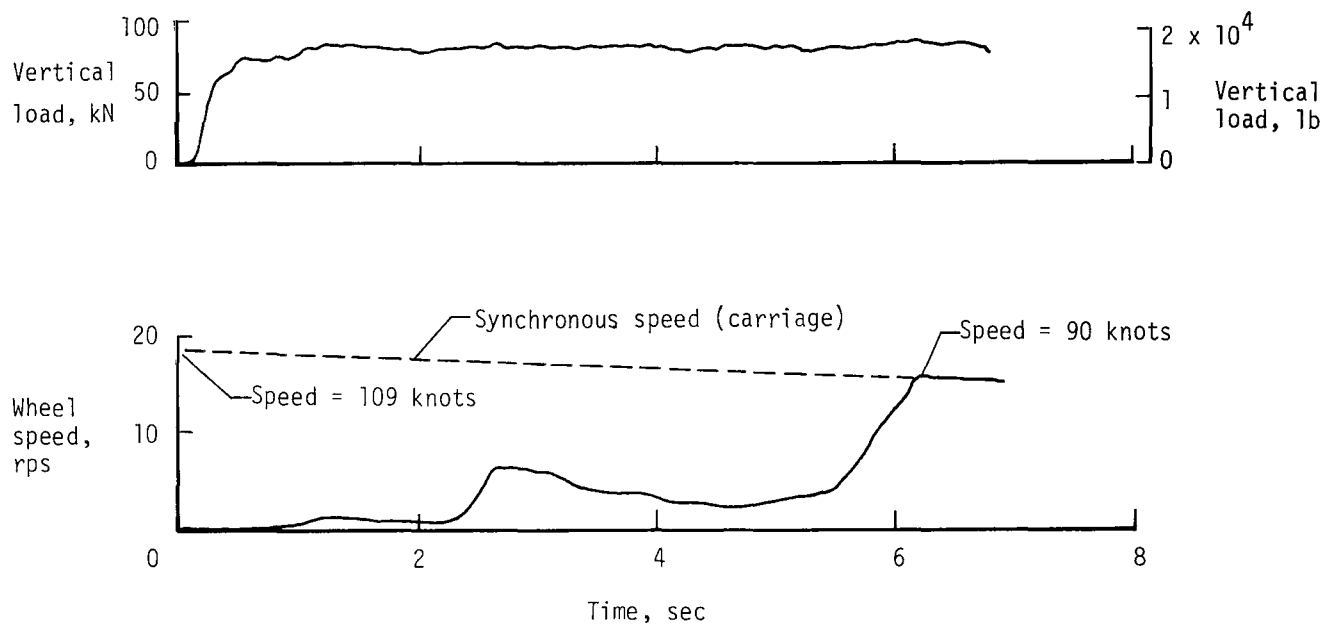

Figure 5.- Unbraked wheel response during touchdown on flooded runway test surface at Langley aircraft landing loads and traction facility. Average water depth, 0.5 cm (0.2 in.).

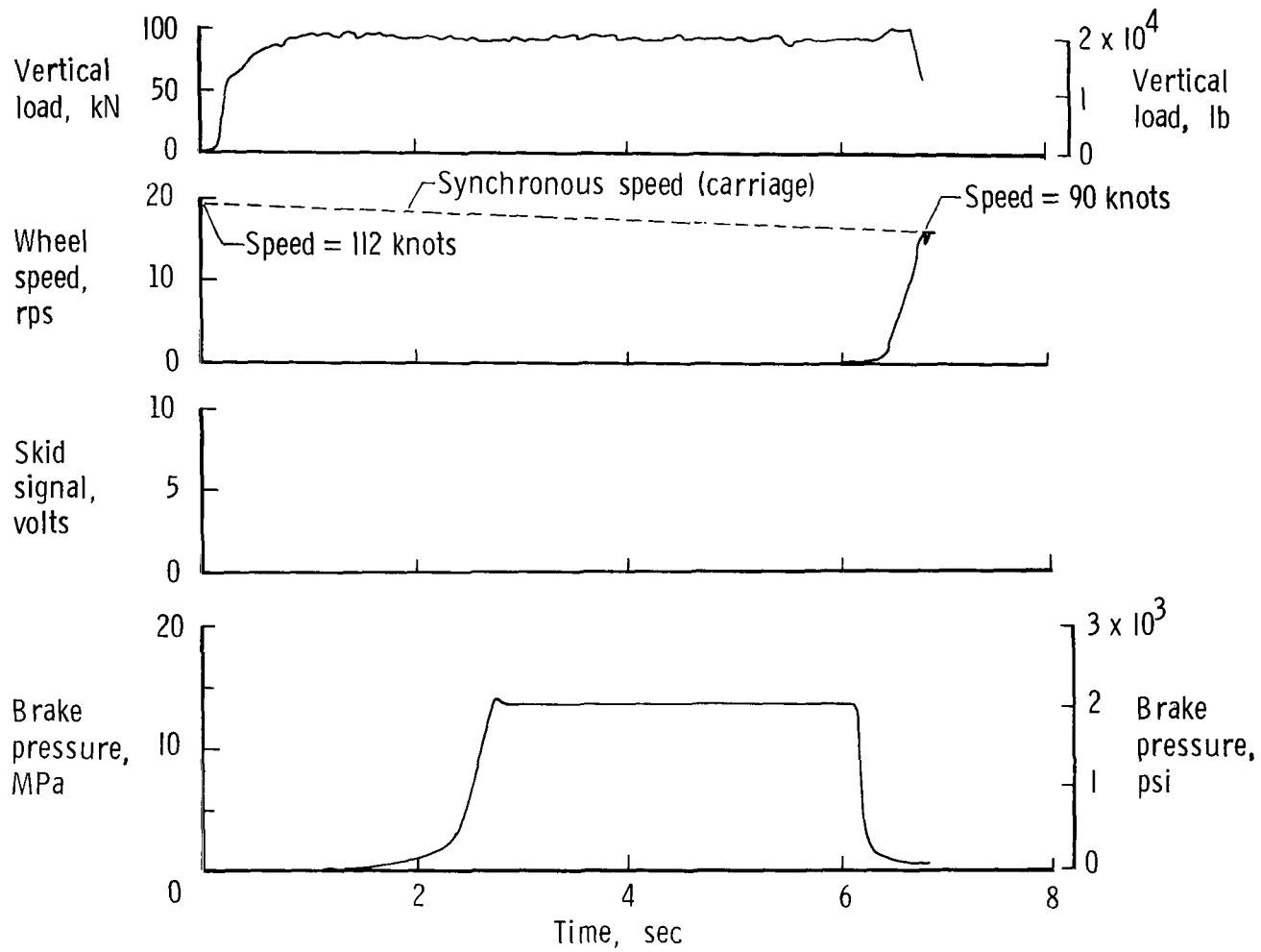
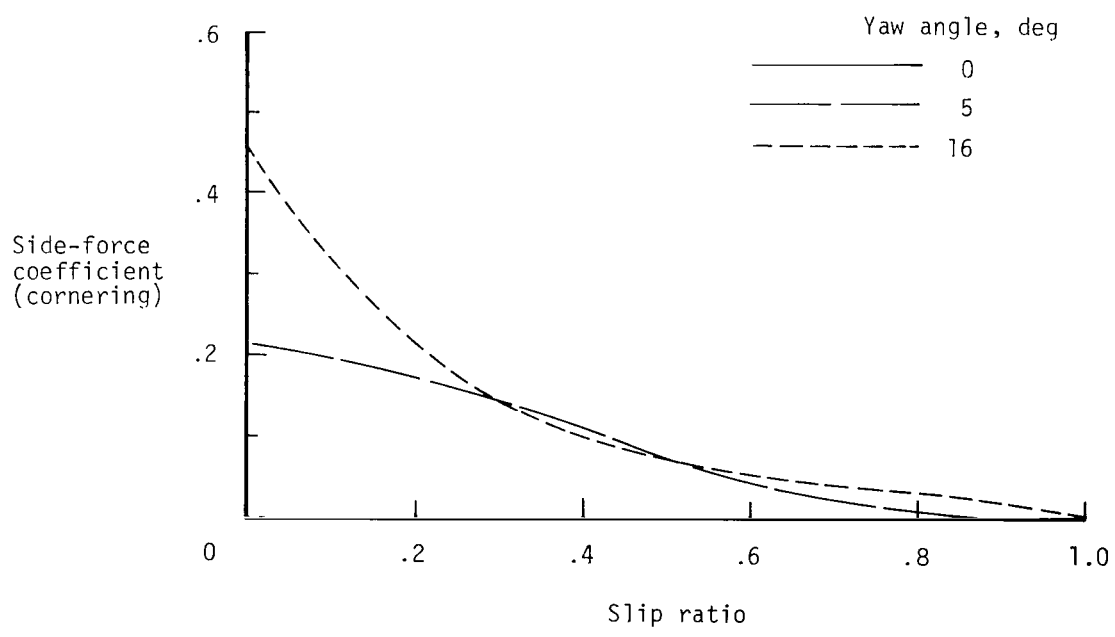
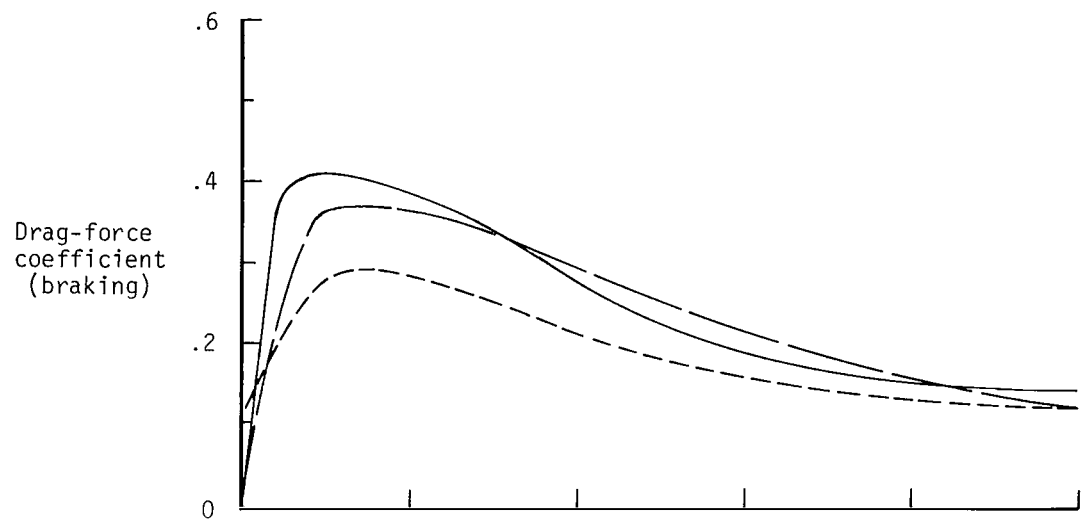
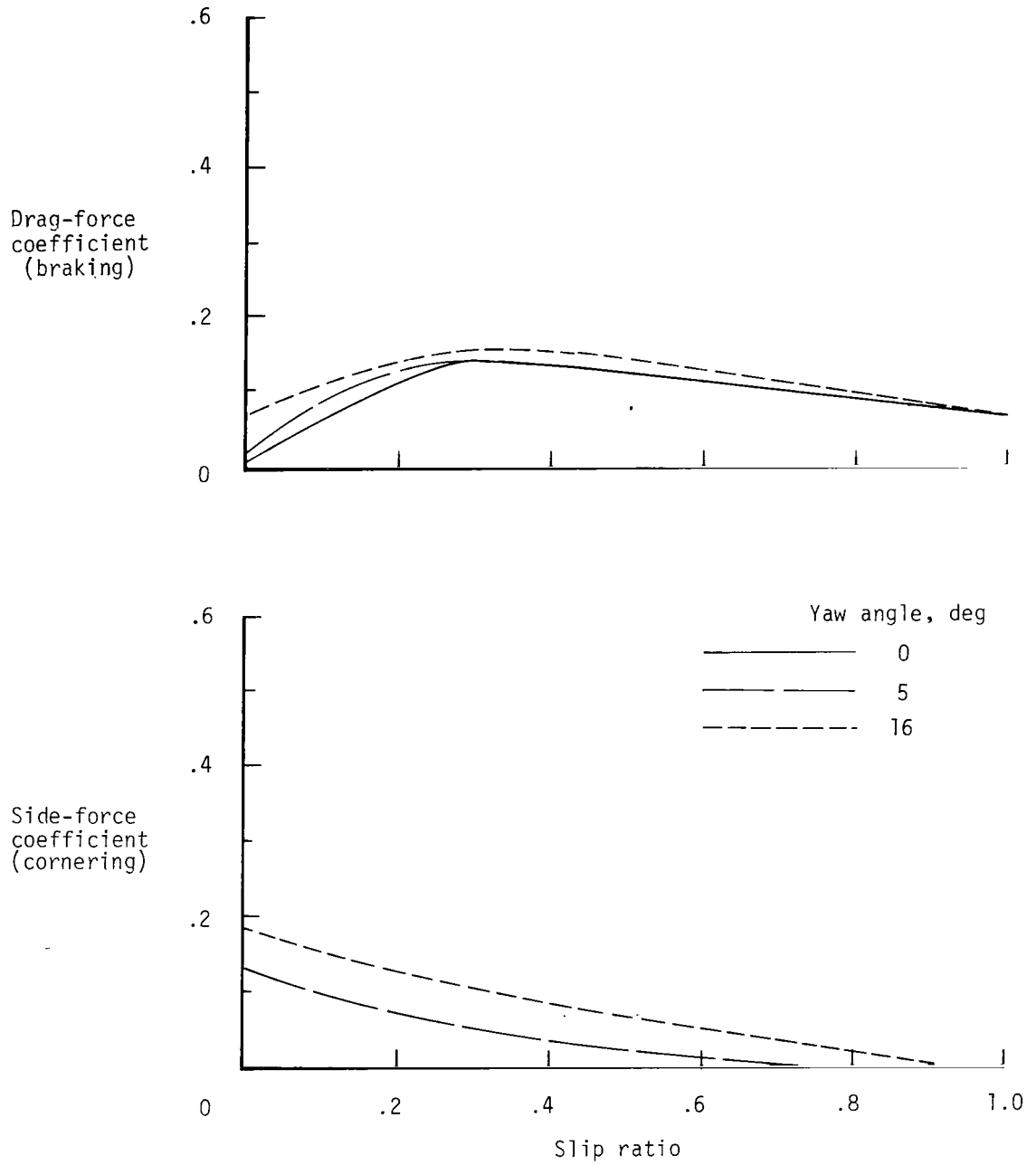

Figure 6.- Effect of tire hydroplaning on touchdown protection.
Average water depth, 0.5 cm (0.2 in.).



(a) Dry surface.

Figure 7.- Variation of drag- and side-force friction coefficients with slip ratio on dry and wet surfaces showing effect of yaw angle. Nominal ground speed, 100 knots.



(b) Wet surface.

Figure 7.- Concluded.

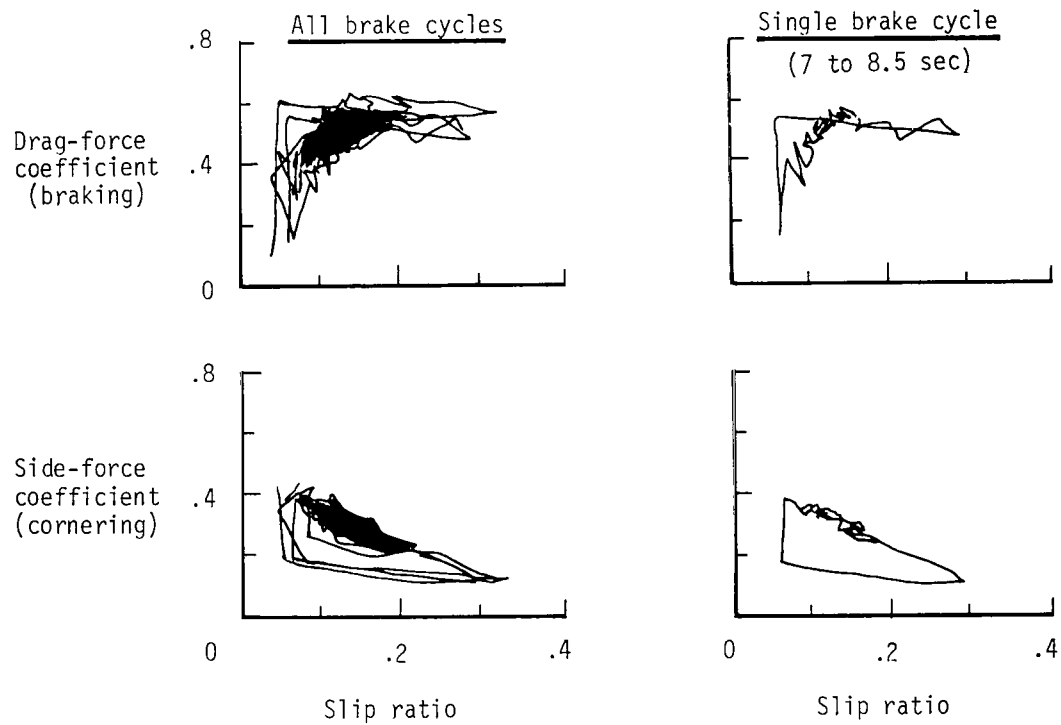
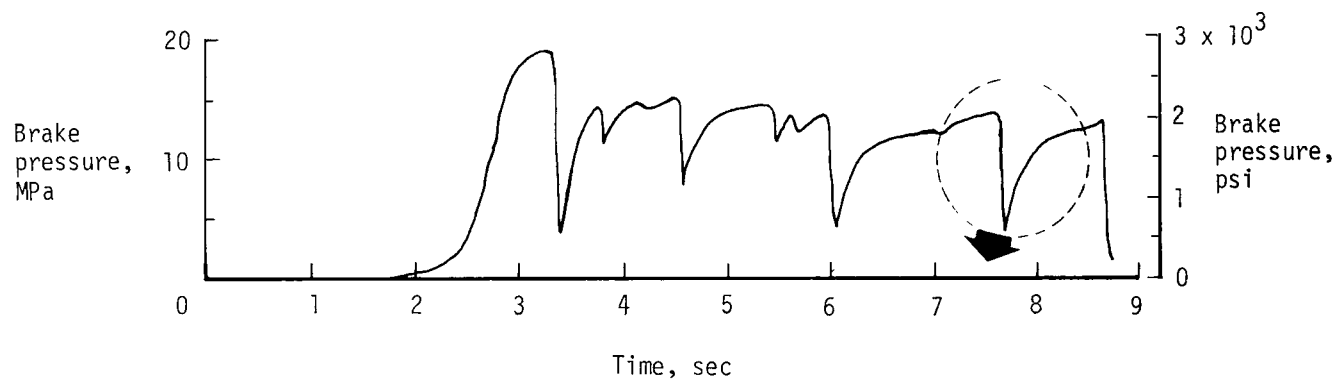

Figure 8.- Variation of drag- and side-force friction coefficients with slip ratio during cyclic braking at 75 knots on dry surface. Yaw angle = 6° .

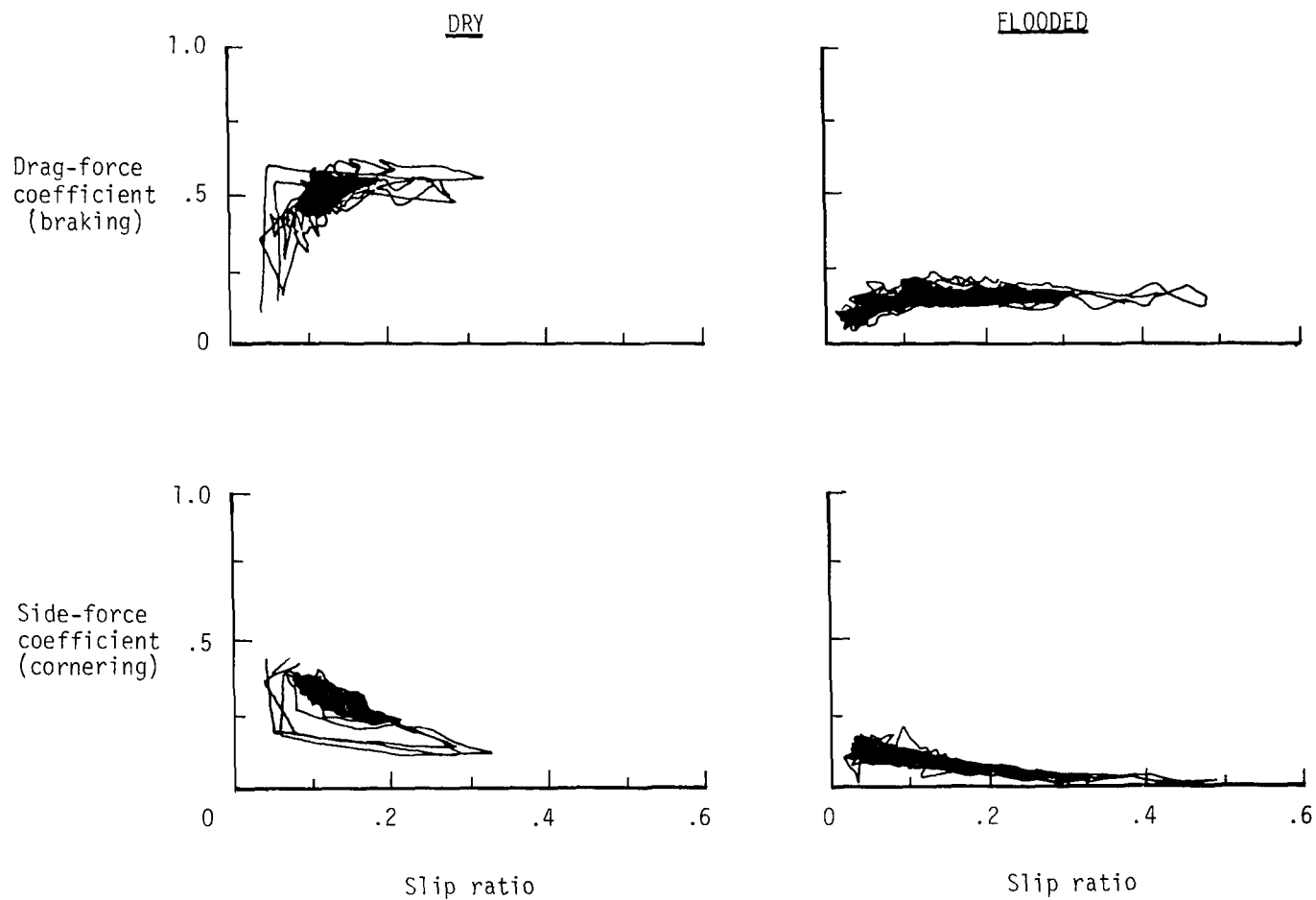
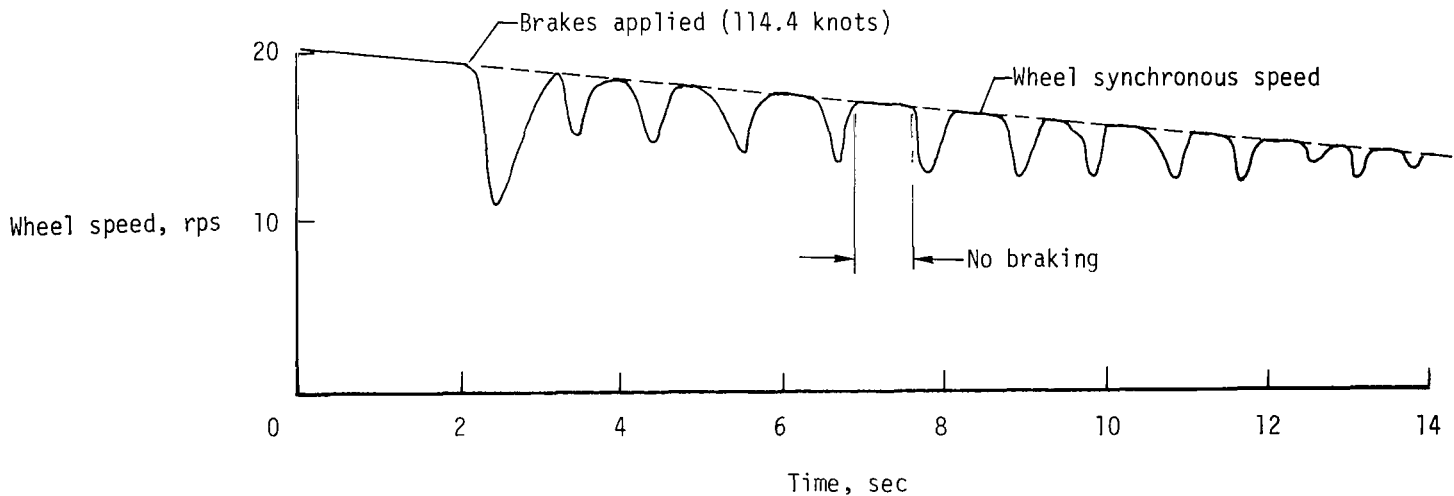
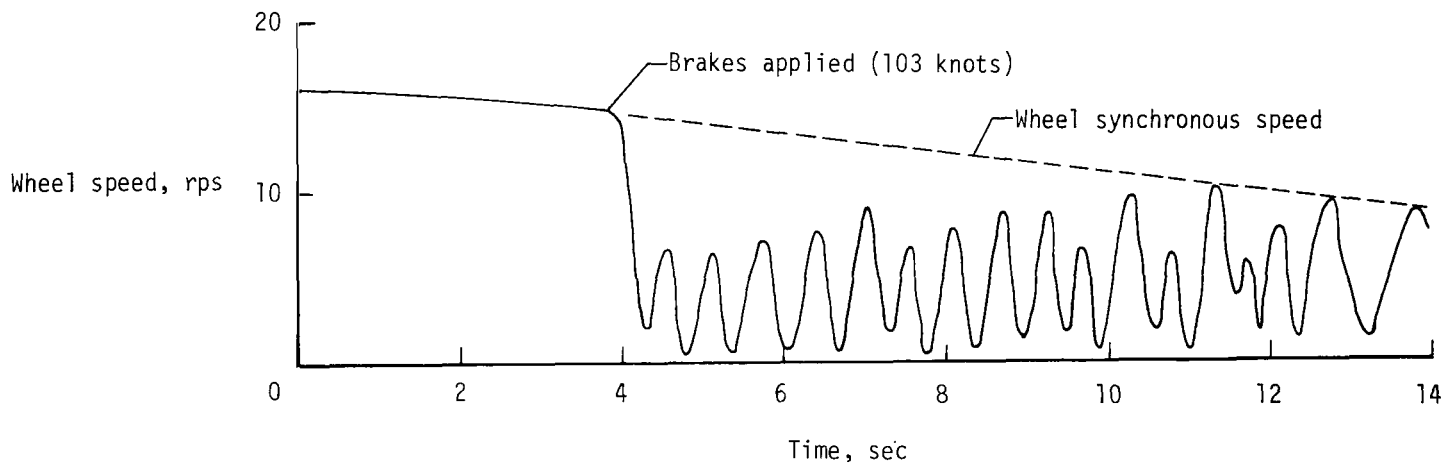

Figure 9.- Comparison of friction coefficients developed during cyclic braking on dry and flooded surfaces at 75 knots. Yaw angle = 6° .



(a) Low wheel slip ratio operation (two-engine jet transport).



(b) High wheel slip ratio operation (three-engine jet transport).

Figure 10.- Typical airplane wheel behavior under antiskid-controlled braking at high speeds on slippery surfaces