

General Disclaimer

One or more of the Following Statements may affect this Document

- This document has been reproduced from the best copy furnished by the organizational source. It is being released in the interest of making available as much information as possible.
- This document may contain data, which exceeds the sheet parameters. It was furnished in this condition by the organizational source and is the best copy available.
- This document may contain tone-on-tone or color graphs, charts and/or pictures, which have been reproduced in black and white.
- This document is paginated as submitted by the original source.
- Portions of this document are not fully legible due to the historical nature of some of the material. However, it is the best reproduction available from the original submission.

**NASA TECHNICAL
MEMORANDUM**

NASA TM X- 73,135

NASA TM X- 73,135

**UNCERTAIN DYNAMICAL SYSTEMS – A DIFFERENTIAL
GAME APPROACH**

Shaul Gutman

**Ames Research Center
Moffett Field, California 94035**

**(NASA-TM-X-73135) UNCERTAIN DYNAMICAL
SYSTEMS: A DIFFERENTIAL GAME APPROACH
(NASA) 25 p HC \$3.50 C SCL 12E**

N76-26217

**Unclas
G3/08 42354**

April 1976

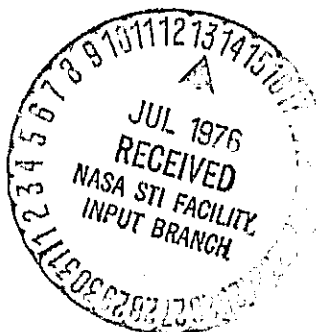

1. Report No. NASA TM X-73,135	2. Government Accession No.	3. Recipient's Catalog No.	
4. Title and Subtitle UNCERTAIN DYNAMICAL SYSTEMS - A DIFFERENTIAL GAME APPROACH		5. Report Date	
		6. Performing Organization Code	
7. Author(s) Shaul Gutman*		8. Performing Organization Report No. A-6606	
		10. Work Unit No. 505-07-11-06	
9. Performing Organization Name and Address Ames Research Center Moffett Field, Calif. 94035		11. Contract or Grant No.	
		13. Type of Report and Period Covered Technical Memorandum	
12. Sponsoring Agency Name and Address National Aeronautics and Space Administration Washington, D. C. 20546		14. Sponsoring Agency Code	
		16. Supplementary Notes *NRC Research Associate, Ames Research Center, NASA, Moffett Field, Calif. 94035	
16. Abstract A class of dynamical systems in a conflict situation is formulated and discussed, and the formulation is applied to the study of an important class of systems in the presence of uncertainty. The uncertainty is deterministic and the only assumption is that its value belongs to a known compact set. Asymptotic stability is fully discussed with application to variable structure and model reference control systems.			
17. Key Words (Suggested by Author(s)) Uncertainty Asymptotic stability Differential game Variable structure		18. Distribution Statement Unlimited STAR Category - 08	
19. Security Classif. (of this report) Unclassified	20. Security Classif. (of this page) Unclassified	21. No. of Pages 26	22. Price* \$3.75

UNCERTAIN DYNAMICAL SYSTEMS -- A DIFFERENTIAL GAME APPROACH

Shaul Gutman

Ames Research Center

SUMMARY

A class of dynamical systems in a conflict situation is formulated and discussed, and the formulation is applied to the study of an important class of systems in the presence of uncertainty. The uncertainty is deterministic and the only assumption is that its value belongs to a known compact set. Asymptotic stability is fully discussed with application to variable structure and model reference control systems.

1. INTRODUCTION

In the past two decades an extensive effort has been made, mainly in the U.S.S.R., to improve dynamic performances of linear systems, using the concept of variable structure systems (VSS) (ref. 1). Roughly speaking, given a linear dynamical system, it is possible to use a "linear" feedback whose gain values vary with the state. In the case of linear systems, VSS is related to bilinear control (ref. 2); the reader can consult reference 3 for this subject. Furthermore, under some conditions, such nonlinear controllers can operate against parameter uncertainty and input disturbances (refs. 4 and 5). In references 4 and 5, the approach is to find an attractive hyperplane in the state space such that the motion there is independent of the disturbance (invariance property). Then, it is possible to study the asymptotic behavior of the system in this hyperplane using the usual linear technique. Since attractivity is a local property, one has to add conditions that guarantee either reaching the attractive hyperplane or approaching the origin outside it (in ref. 4 such conditions are called "fall conditions"). However, for some multivariable systems this procedure may be too complicated. In addition, references 4 and 5 lack a priori conditions for stability. It should be mentioned that in some non-trivial cases it is possible to stabilize a linear system in the presence of parameter uncertainty using a linear feedback (ref. 6) by modifying the Riccati equation. Although the feedback control is simple, there are no a priori conditions for stability. In the case of linear time invariant systems with some unknown parameters, it is useful to use an adaptive model reference scheme (refs. 7 and 8) which assumes some "matching conditions" (ref. 9).

In this article, we develop stabilizing controllers for a class of non-linear systems homogeneous in the input, in the presence of uncertainty. We consider the uncertain system from the viewpoint of a conflict between uncertainty and controller. We associate with the dynamics a cost function and find a saddle point for finite transfer time. In checking asymptotic

properties of the system we note that the saddle point controller may be discontinuous. Thus, we use "generalized dynamical systems" theory to define a solution of the resulting discontinuous dynamical system (refs. 11-12; see also 13). Some results with respect to nominal linear systems (i.e., the system without uncertainty is linear) are reported in reference 14. Stability and optimal control for the nonlinear case without uncertainty are studied in reference 15. It is interesting to note that our conditions on the system's structure and the "invariance condition" of references 4 and 5 are both equivalent to the "matching conditions" (refs. 7-9). The main drawback of the present method (as in optimal control) is the necessity to measure the complete state vector.

In section 2 we formulate and solve a simple differential game for finite terminal time. Motivated by the saddle point strategy, we study in sections 3 and 4 the asymptotic behavior of uncertain systems. In section 5 we apply the results to nominal linear systems with special attention to VSS. Applications to model reference control in the presence of uncertainty are discussed in section 6.

I am grateful to Prof. G. Leitmann for his critical reading and encouragement, and to Prof. E. Polak for drawing my attention to reference 5.

2. A SIMPLE DIFFERENTIAL GAME

Consider the dynamics

$$\dot{x} = f(x,t) + B(x,t)(u + \eta), \quad x(t_0) = x_0 \quad (1)$$

$$u \in U = \{u: u'R^{-1}u \leq \rho^2(x,t)\} \quad (2)$$

$$\eta \in V = \{\eta: \eta'R^{-1}\eta \leq \rho^2(x,t)\}$$

where $x \in \mathbb{R}^n$, $u, \eta \in \mathbb{R}^m$, $B \in \mathbb{R}^{n \times m}$, $B(\cdot)$ is continuous on \mathbb{R}^{n+1} , $f(\cdot)$ will be specified later, $R = M'M$ is a constant positive definite symmetric matrix, and $\rho(\cdot)$ is a continuous scalar function on \mathbb{R}^{n+1} . With (1)-(2) we associate the cost

$$J = \int_{t_0}^T g(x,t) dt \quad (3)$$

where T is fixed and $g(\cdot)$ will be specified later. For system (1)-(2) we seek a saddle point strategy pair $\{p^*(\cdot), e^*(\cdot)\}$ in the class of strategy pairs $\{p(\cdot), e(\cdot)\}$ satisfying the hypotheses of reference 16, such that $u(t) = p(x(t), t)$, $\eta(t) = e(x(t), t)$; and $\forall (x_0, t_0) \in \mathbb{R}^n \times (-\infty, T]$

$$J(x_0, t_0, p^*(\cdot), e(\cdot)) \leq J(x_0, t_0, p^*(\cdot), e^*(\cdot)) \leq J(x_0, t_0, p(\cdot), e^*(\cdot)) \quad (4)$$

In order to find $\{p^*(\cdot), e^*(\cdot)\}$, we restrict $f(\cdot), g(\cdot)$ as follows:

Assumption 1: The functions $f(\cdot), g(\cdot)$ are C^1 on \mathbb{R}^{n+1} .

Since U and V are identical sets, we expect (4) to be satisfied at $p^*(\cdot) = -e^*(\cdot)$. Then, equation (1) becomes $\dot{x}^* = f(x^*, t)$ and the cost (3) is evaluated along $x^*(\cdot)$; namely $J = J(x_0, t_0, p^*(\cdot), e^*(\cdot)) \triangleq v^*(x_0, t_0)$. Since $f(\cdot), g(\cdot)$ are C^1 , the above cost is C^1 with respect to (x_0, t_0) .

Using Isaacs' equation (ref. 17),

$$\text{Min}_{u \in U} \text{Max}_{\eta \in V} \left[g(x, t) + \text{grad } v^*(x, t) \cdot (f(x, t) + B(x, t)(u + \eta)) \right] = 0,$$

we find

$$p^*(x, t) = -e^*(x, t) = -\rho(x, t) M' \frac{MB'(x, t) \text{grad}' v^*(x, t)}{\|MB'(x, t) \text{grad}' v^*(x, t)\|} V(x, t) \notin \mathcal{N}$$

$$\{p^*(\cdot), e^*(\cdot)\} \quad \text{is any admissible pair} \quad V(x, t) \in \mathcal{N} \quad (5)$$

$$\mathcal{N} \triangleq \{(x, t) : B'(x, t) \text{grad}' v^*(x, t) = 0\}$$

Remark 1: If (2) is replaced by

$$\begin{aligned} U &= \{u \in \mathbb{R}^m : |u_i| \leq \rho_i(x, t)\} \\ V &= \{\eta \in \mathbb{R}^m : |\eta_i| \leq \rho_i(x, t)\}, \end{aligned} \quad (2')$$

then $\{p^*(\cdot), e^*(\cdot)\}$ becomes

$$p_i^*(x, t) = -e_i^*(x, t) = -\rho_i(x, t) \text{sgn} \left[b_i'(x, t) \text{grad}' v^*(x, t) \right] V(x, t) \notin \mathcal{N}_1$$

$$\{p_i^*(\cdot), e_i^*(\cdot)\} \quad \text{is any admissible pair} \quad V(x, t) \in \mathcal{N}_1 \quad (5')$$

$$\mathcal{N}_1 \triangleq \{(x, t) : b_i'(x, t) \text{grad}' v^*(x, t) = 0\}, \quad B \triangleq [b_1 \dots b_m].$$

We conclude with

Theorem 1: Consider the differential games (1), (2), (3) and (1), (2'), (3). The strategy pairs $\{p^*(\cdot), e^*(\cdot)\}$ given by (5) and (5'), respectively, are saddle points on $\mathbb{R}^n \times (-\infty, T]$.

Now that theorem 1 is established, the application to the control of uncertain systems is straightforward. If a system of the form $\dot{x} = F(x, t, u)$ has an uncertainty (in the parameters, input or both) that can be transformed into a system of the form $\dot{x} = f(x, t) + B(x, t)(u + \eta)$ and if the controller

u uses $p^*(\cdot)$ given by (5) or (5'), he is guaranteed the cost (3) evaluated along solution of $\dot{x} = f(x,t)$. Note that the identity of sets U and V is essential for establishing the saddle point. Practically speaking, after verifying the above form, we bound the uncertainty by V as in (2) or (2'), even if we have to be conservative. Then we define U to be identical to V as in (2) or (2').

3. STABILITY OF A CLASS OF UNCERTAIN SYSTEMS

We now turn our attention to the asymptotic behavior of (1). We first relax assumption 1 by making the following assumption.

Assumption 2: The function $f(\cdot)$ is continuous on \mathbb{R}^{n+1} and $f(0,t) = 0 \quad \forall t \in \mathbb{R}_+^1$.

We also need

Assumption 3: The origin $x = \{0\}$ is uniformly asymptotically stable in the large for $\dot{x} = f(x,t)$, such that there exists a C^1 function $v(\cdot): \mathbb{R}^{n+1} \rightarrow \mathbb{R}^1$ satisfying (ref. 18):

1. $v(x,t)$ is positive definite (p.d.): \exists a continuous, nondecreasing scalar function $\alpha(\cdot)$ with $\alpha(0) = 0$, such that $\forall t \in \mathbb{R}_+^1$ and $\forall x \in \mathbb{R}^n, x \neq 0$

$$0 < \alpha(\|x\|) \leq v(x,t)$$

2. $v(x,t)$ has an "infinitely small upper bound": \exists a continuous non-decreasing scalar function $\beta(\cdot)$ with $\beta(0) = 0$, such that $\forall t \in \mathbb{R}_+^1$

$$v(x,t) \leq \beta(\|x\|)$$

3. $\alpha(\|x\|) \rightarrow \infty$ as $\|x\| \rightarrow \infty$

4. $W_0(x,t) \triangleq \frac{\partial v}{\partial t} + \text{grad } v \cdot f$ is negative definite (n.d.).

Assumption 4: Admissible strategy $e(\cdot): \mathbb{R}^n \times \mathbb{R}_+^1 \rightarrow V$ is continuous on \mathbb{R}^n and piecewise continuous on any compact subinterval of \mathbb{R}_+^1 .

Motivated by (5) and (5') we associate with (2) and (2'), respectively, the feedback strategies $\tilde{p}(\cdot): \mathbb{R}^n \times \mathbb{R}_+^1 \rightarrow U$ given, respectively, by

$$\tilde{p}(x,t) = \begin{cases} -\rho(x,t)M' \frac{MB'(x,t)\text{grad}' v(x,t)}{\|MB'(x,t)\text{grad}' v(x,t)\|} & V(x,t) \notin A \\ u \in U = \{u \in \mathbb{R}^m : u'R^{-1}u \leq \rho^2(x,t)\} & V(x,t) \in A \end{cases} \quad (6)$$

$$A \triangleq \{(x,t) : B'(x,t)\text{grad}' v(x,t) = 0\} \quad (6a)$$

and

$$\tilde{p}_i(x,t) = \begin{cases} -\rho_i(x,t) \operatorname{sgn}[b_i'(x,t) \operatorname{grad}' v(x,t)] & v(x,t) \notin \mathcal{N}_i \\ u_i \in U_i = \{u_i \in \mathbb{R}^1 : |u_i| \leq \rho_i(x,t)\} & v(x,t) \in \mathcal{N}_i \end{cases} \quad (7)$$

$$\mathcal{N}_i \triangleq \{(x,t) : b_i'(x,t) \operatorname{grad}' v(x,t) = 0\}, \quad i \in \{1, 2, \dots, m\}, \quad (7a)$$

where the b_i' 's are the columns of B .

We now have

Theorem 2: Consider the dynamical systems (1)-(2) and (1)-(2'). If we suppose that assumptions 2-4 are met, then there exists a feedback control $\tilde{p}(\cdot)$ satisfying (6) and (7), respectively, such that the origin $x = \{0\}$ is uniformly asymptotically stable in the large for all admissible disturbances $e(\cdot)$.

Proof: Since $\tilde{p}(\cdot)$ is discontinuous and hence considered not unique, equation (1) becomes a generalized dynamical system (refs. 11 and 12),

$$x \in E(x,t) \quad (8)$$

where the set valued function $E(\cdot)$ is given by

$$E(x,t) = \{f(x,t) + B(x,t)u + B(x,t)e(x,t) : u = \tilde{p}(x,t)\} \quad (8a)$$

It can be shown (see appendix) that

1. $E(x,t)$ is convex $V(x,t) \in \mathbb{R}^n \times \mathbb{R}_+^1$
2. $E(x,t)$ is compact $V(x,t) \in \mathbb{R}^n \times \mathbb{R}_+^1$
3. $E(\cdot)$ is upper semicontinuous on $\mathbb{R}^n \times \mathbb{R}_+^1$

Thus, given any $(x_0, t_0) \in \mathbb{R}^n \times \mathbb{R}_+^1$ there exists at least one solution of (8). That any such solution can be continued¹ on \mathbb{R}_+^1 is one of the consequences of the properties of the following Lyapunov function. Let $v(\cdot) : \mathbb{R}^n \times \mathbb{R}_+^1 \rightarrow \mathbb{R}^1$ of assumption 3 be a Lyapunov function candidate. We now show that $\dot{v}x(t)$ decreases along a solution $x(\cdot)$ of (1) generated by $\{\tilde{p}(\cdot), e(\cdot)\}$.

¹At points of discontinuity of $e(x, \cdot)$, solutions can be joined in the usual way.

For $(x(t), t) \notin \mathcal{N}$ in system (1)-(2),²

$$\begin{aligned}
 W(t) &\triangleq \frac{\partial U}{\partial t} + \text{grad } u \cdot \dot{x} \\
 &= \frac{\partial U}{\partial t} + \text{grad } u \cdot [f + B\tilde{p} + Be] \\
 &= \frac{\partial U}{\partial t} + \text{grad } u \cdot f - \rho \frac{\text{grad } u B M' M B' \text{grad}' u}{\|M B' \text{grad}' u\|} \\
 &= W_0(x(t), t) - \rho \|M B' \text{grad}' u\| + \text{grad } u \cdot Be \\
 &\leq W_0(x(t), t) - \rho \|M B' \text{grad}' u\| + \rho \|M B' \text{grad}' u\| \\
 &= W_0(x(t), t) < 0
 \end{aligned}$$

For $(x(t), t) \in \mathcal{N}$ but $x(t) \neq 0$,

$$W(t) = W_0(x(t), t) < 0 .$$

Q.E.D.

Similar results are obtained for system (1)-(2').

Remark 2: If in equation (2)

$$U = \{u : u' R^{-1} u \leq \rho_u^2(x, t)\}$$

$$V = \{\eta : \eta' R^{-1} \eta \leq \rho_v^2(x, t)\}$$

then we use $\rho_u(x, t)$ in (6), where $\rho_u(x, t) \geq \rho_v(x, t)$. A similar statement holds for (2'), (7).

Integrating $W(t)$, we find

Corollary 1: The average measure of deviation from the origin along a solution $x(\cdot) : [t_0, \infty] \rightarrow \mathbb{R}^n$, $x(t_0) = x_0$, generated by $\{p(\cdot), e(\cdot)\}$ is

$$\int_{t_0}^{\infty} -W_0(x(t), t) dt \leq u(x_0, t_0) .$$

4. APPLICATION TO PARAMETER AND INPUT UNCERTAINTY

Consider the uncertain dynamical system

$$\dot{x} = f(x, t) + \delta f(x, t, v) + B(x, t)u + C(x, t)w \quad (9)$$

²For simplicity we drop function's arguments.

where $f, \delta f \in \mathbb{R}^n$, $B \in \mathbb{R}^{n \times m}$, $C \in \mathbb{R}^{n \times r}$, $u \in \mathbb{R}^m$, $\delta f(\cdot)$ is continuous. The uncertainty vector functions $v(\cdot): \mathbb{R}^n \times \mathbb{R}_+^1 \rightarrow \mathbb{R}^q$, $w(\cdot): \mathbb{R}^n \times \mathbb{R}_+^1 \rightarrow \mathbb{R}^r$ are continuous and satisfy $(v, w) \in \Omega$, where

$$\Omega \triangleq \left\{ v \in \mathbb{R}^q, w \in \mathbb{R}^r : |v_i| \leq 1, \quad i = 1, 2, \dots, q; \quad \|w\| \leq \rho_w \right\} \quad (10)$$

We now require

Assumption 5: For all $(x, t) \in \mathbb{R}^n \times \mathbb{R}_+^1$ there exists a continuous vector function $h(x, t, v) \in \mathbb{R}^m$ and a continuous matrix function $D(x, t) \in \mathbb{R}^{m \times r}$, such that

$$\begin{aligned} (i) \quad \delta f(x, t, v) &= B(x, t)h(x, t, v) \\ (ii) \quad C(x, t) &= B(x, t)D(x, t) \end{aligned} \quad (11)$$

We refer to (i)-(ii) as "matching conditions".

Remark 3: The matching conditions are properties only of the system's structure. They guarantee that the controller u influences the dynamics in equation (10) as "well" as the disturbance $\delta f + Cw$ does.

If (11) is satisfied, (10) becomes

$$\dot{x} = f(x, t) + B(x, t)(u + h(x, t, v) + D(x, t)w) \quad (12)$$

Denoting $h + Dw$ by η , equation (12) reduces to the form of (1).

Remark 4: If $\dot{x} = f(x, t)$ is not asymptotically stable, we have to stabilize it via $B(x, t)u$. The subject of stabilizing a system of the form $\dot{x} = f(x, t) + B(x, t)u$ is considered in reference 15.

Applying theorem 2 to equation (12), we find

Theorem 3: Consider the uncertain system (9)-(10) and suppose assumptions 2-5 are satisfied. If $\tilde{p}(\cdot): \mathbb{R}^n \times \mathbb{R}_+^1 \rightarrow U$ is given by (6) with $\rho(x, t) \geq \rho_w + \sqrt{\text{Max} \|h(x, t, v)\|}$, $u = \tilde{p}(x, t)$, then the origin $x = \{0\}$ is uniformly asymptotically stable in the large for all admissible (v, w) .

5. APPLICATIONS TO NOMINALLY³ LINEAR SYSTEMS

5.1 Parameter Uncertainty

Consider the uncertain system (9) with $f(x, t) \triangleq Ax$; that is

$$\dot{x} = (A + \Delta A(v))x + Bu$$

³That is, without uncertainty the system is linear.

where $A \in \mathbb{R}^{n \times n}$, $B \in \mathbb{R}^{n \times m}$ are constant matrices, A is asymptotically stable: all its eigenvalues have negative real parts, $A \triangleq [a_{ij}]$; $\Delta A(v) \triangleq [\alpha_{ij} v_{ij}]$; $\alpha_{ij} = \text{constant}$, $i, j \in \{1, 2, \dots, n\}$. The uncertainty vector function $v(\cdot): \mathbb{R}^n \times \mathbb{R}_+^1 \rightarrow \mathbb{R}^q$ is continuous and satisfies $v \in \Omega$, where

$$\Omega \triangleq \{v \in \mathbb{R}^q : |v_{ij}(\cdot)| \leq 1, \quad i, j \in \{1, 2, \dots, n\}\}$$

Let matching conditions (11) be satisfied:

There exists a continuous $F(\cdot): \mathbb{R}^k \rightarrow \mathbb{R}^{m \times n}$ such that $\forall v \in \Omega$

$$\Delta A(v) = BF(v)$$

The state equation becomes

$$\dot{x} = Ax + B(u + F(v)x)$$

$$\hat{=} Ax + B(u + \eta)$$

Applying the results of section 5 (eq. (6) with $R = I$, $v(x, t) = x'Px$), we find a stabilizing feedback control $\tilde{p}(\cdot): \mathbb{R}^n \times \mathbb{R}_+^1 \rightarrow \mathbb{R}^m$, $u(t) = \tilde{p}(x(t), t)$, satisfying

$$\tilde{p}(x, t) = \begin{cases} -\frac{\text{Max}_v \|F(v)x\|}{v} \frac{B'Px}{\|B'Px\|} & (x, t) \notin \mathcal{N} \\ u \in U = \{u \in \mathbb{R}^m : \|u\| \leq \frac{\text{Max}_v \|F(v)x\|}{v}\} & (x, t) \in \mathcal{N} \end{cases} \quad (13)$$

where

$$PA + A'P + Q = 0, \quad Q = Q' > 0, \quad \text{and} \quad \mathcal{N} \triangleq \{(x, t) : B'Px = 0\}$$

Remark 5: Here the origin is an equilibrium point in the usual sense, since $\lim_{x \rightarrow 0} \tilde{p}(x, t) = 0$. This holds in the following two examples as well.

5.2 System of Section 5.1 in Companion Form with Single Input

Let

$$\dot{x} = (A + \Delta A(v))x + bu; \quad \Delta A(v) = \sum_{i=1}^k A_i v_i(x, t)$$

where⁴

$$A = \begin{bmatrix} 0 & 1 & 0 & \dots & 0 \\ 0 & 0 & 1 & \dots & 0 \\ \vdots & \vdots & \vdots & \ddots & \vdots \\ \vdots & \vdots & \vdots & \ddots & \vdots \\ 0 & 0 & 0 & \dots & 1 \\ -a_1 & -a_2 & -a_3 & \dots & -a_n \end{bmatrix} \quad A_i = \begin{bmatrix} \text{---} & \text{---} & \text{---} & \text{---} & \text{---} \\ \text{---} & \text{---} & \text{---} & \text{---} & \text{---} \\ \text{---} & \text{---} & \text{---} & \text{---} & \text{---} \\ \text{---} & \text{---} & \text{---} & \text{---} & \text{---} \\ 0 & \dots & 0 & \alpha_i & 0 & \dots & 0 \end{bmatrix} \quad b = \begin{bmatrix} 0 \\ \vdots \\ 1 \end{bmatrix}$$

$a_j = \text{constant}, j = 1, 2, \dots, n$

$\alpha_i = \text{constant}, i = 1, 2, \dots, k; k \leq n$

$$|v_i(x, t)| \leq 1$$

Here, $F(v) = c'(v)x$ where $c'(v) = [\alpha_1 v_1 \dots \alpha_n v_n]$.

Equation (13) becomes

$$\tilde{p}(x, t) = \begin{cases} -\text{Max}_{|v_i| \leq 1} [c'(v)x] \text{sgn } \pi'x & V(x, t) \notin \mathcal{N} \\ u \in \{u \in \mathbb{R}^1 : |u| \leq \text{Max}_{|v_i| \leq 1} [c'(v)x]\} & V(x, t) \in \mathcal{N} \end{cases} \quad (14a)$$

where π is the n -th column of the symmetric matrix P satisfying $PA + A'P + Q = 0, Q = Q' > 0$, and $\mathcal{N} = \{(x, t) : \pi'x = 0\}$.

Remark 6: Note that $\text{Max}_{|v_i| \leq 1} [c'(v)x] \leq \left(\sum_{i=1}^k \alpha_i^2\right)^{1/2} \|x\|$

Equation (14a) subject to remark 6 yields one possible solution for $\tilde{p}(\cdot)$. A second one is found by noting that

$$\text{Max}_{|v_i| \leq 1} [c'(v)x] = \sum_i \alpha_i \text{Max}_{|v_i| \leq 1} (v_i x_i) = \sum_i \alpha_i |x_i|$$

⁴In the terminology of section 5.1, $v_i \triangleq v_{ni}, i = 1, 2, \dots, n$.

Thus, $(x, t) \in \mathcal{N}$,

$$\begin{aligned} \tilde{p}(x, t) &= - \sum_1 \alpha_1 |x_1| \operatorname{sgn} \pi' x = - \sum_1 \alpha_1 x_1 \operatorname{sgn} x_1 \pi' x \\ &\triangleq [\alpha_1 \xi_1 \dots \alpha_n \xi_n] x \end{aligned}$$

where

$$\xi_1 = - \operatorname{sgn} x_1 \pi' x$$

We conclude that

$$\tilde{p}(x, t) = K(\xi) x$$

$$K(\xi) = [\alpha_1 \xi_1 \dots \alpha_n \xi_n]$$

$$\xi_1 = \begin{cases} -\operatorname{sgn} x_1 \pi' x & V(x, t) \notin \mathcal{N} \\ \gamma_1 \in \{\gamma_1 \in \mathbb{R}^1 : |\gamma_1| \leq 1\} & V(x, t) \in \mathcal{N} \end{cases} \quad (14b)$$

$$\mathcal{N} = \{(x, t) : \pi' x = 0\},$$

π is the n -th column of P , $PA + A'P + Q = 0$, $Q = Q'$ is any positive definite matrix.

Example 1: Let $x \in \mathbb{R}^2$ with

$$\dot{x} = \begin{bmatrix} 0 & 1 \\ -a_1 + \Delta a_1 & -a_2 \end{bmatrix} x + \begin{bmatrix} 0 \\ 1 \end{bmatrix} u$$

where $\Delta a_1 = \alpha_1 v_1$, $|v_1| \leq 1$, $\alpha_1 = \text{constant}$. We assume that

$$A = \begin{bmatrix} 0 & 1 \\ -a_1 & -a_2 \end{bmatrix}$$

has all its eigenvalues in the left half plane (otherwise it must be stabilized by linear feedback). Equation (14b) becomes

$$\tilde{p}(x, t) = K(\xi) x = [\alpha_1 \xi_1 \mid 0] \begin{bmatrix} x_1 \\ \dots \\ x_2 \end{bmatrix}$$

where $\xi_1(x, t) = -\operatorname{sgn}(x_1 \pi' x)$.

If $D_1 \triangleq D_1' \cup D_1''$, then

$$x \in D_1: \dot{p}(x, t) = - \begin{bmatrix} -\alpha_1 & 0 \\ \dots & \dots \end{bmatrix} \begin{bmatrix} x_1 \\ \dots \\ x_2 \end{bmatrix}$$

$$x \in D_2: \dot{p}(x, t) = - \begin{bmatrix} \alpha_1 & 0 \\ \dots & \dots \end{bmatrix} \begin{bmatrix} x_1 \\ \dots \\ x_2 \end{bmatrix}$$

where $\{D_1, D_2\}$ is defined in figure 1.

Example 2: Let $x \in \mathbb{R}^2$ with

$$\dot{x} = \begin{bmatrix} 0 & 1 \\ -a_1 + \Delta a_1 & -a_2 + \Delta a_2 \end{bmatrix} x + \begin{bmatrix} 0 \\ 1 \end{bmatrix} u$$

where $\Delta a_i = \alpha_i v_i$, $|v_i| \leq 1$, $\alpha_i = \text{constant}$, $i = 1, 2$. As in example 1, let A have all its eigenvalues in the left half plane. Equation (14b) becomes

$$\dot{p}(x, t) = K(\xi)x = \begin{bmatrix} \alpha_1 \xi_1 & \alpha_2 \xi_2 \\ \dots & \dots \end{bmatrix} \begin{bmatrix} x_1 \\ \dots \\ x_2 \end{bmatrix}$$

where $\xi_i(x, t) = -\text{sgn}(x_i \pi' x)$, $i = 1, 2$.

If $D_1 \triangleq D_1' \cup D_1''$, then

$$x \in D_1: \dot{p}(x, t) = - \begin{bmatrix} -\alpha_1 & \alpha_2 \\ \dots & \dots \end{bmatrix} \begin{bmatrix} x_1 \\ \dots \\ x_2 \end{bmatrix}$$

$$x \in D_2: \dot{p}(x, t) = - \begin{bmatrix} \alpha_1 & \alpha_2 \\ \dots & \dots \end{bmatrix} \begin{bmatrix} x_1 \\ \dots \\ x_2 \end{bmatrix}$$

$$x \in D_3: \dot{p}(x, t) = - \begin{bmatrix} \alpha_1 & -\alpha_2 \\ \dots & \dots \end{bmatrix} \begin{bmatrix} x_1 \\ \dots \\ x_2 \end{bmatrix}$$

where $\{D_1, D_2, D_3\}$ is defined in figure 2.

5.3 Variable Structure Systems

An alternative way to stabilize the systems of sections 5.1 and 5.2 is as follows:

Let

$$\dot{x} = (A + \Delta A(v))x + Bu \tag{15}$$

where A and B are constant matrices. As before, let

$$\Delta A(v) = BF(v) \quad (15a)$$

where $v \in \Omega$ is the parameter uncertainty vector with

$$\Omega \triangleq \{v \in \mathbb{R}^k : |v_{1j}| \leq 1; \quad 1, j = 1, 2, \dots, n\}.$$

We wish to use a stabilizing control of the form

$$u = K(\xi)x$$

where $\xi \in \Omega$ is the control parameter vector, and $\xi(\cdot): \mathbb{R}^n \times \mathbb{R}_+^1 \rightarrow \mathbb{R}^k$. That is, we use a "linear" feedback whose "coefficients" vary with the state and time. Using (15a) and (15b) in (15), we find

$$\dot{x} = Ax + B(K(\xi) + F(v))x \quad (16)$$

Equation (16) can always be written in the form

$$\dot{x} = Ax + M(x)(\xi + v) \quad (17)$$

where $M(x)$ has the proper dimension.

Since equation (17) has the form of (1), we can use our previous results. In particular, consider the system of section 5.2. Here,

$$\begin{aligned} F(v) &= \begin{bmatrix} \alpha_1 v_1 & \dots & \alpha_n v_n \end{bmatrix} \\ K(\xi) &= \begin{bmatrix} \alpha_1 \xi_1 & \dots & \alpha_n \xi_n \end{bmatrix} \end{aligned} \quad (17a)$$

$$M(x) = \begin{bmatrix} \text{---} \text{---} \text{---} \text{---} \text{---} \text{---} \\ \alpha_1 x_1 & \dots & \alpha_n x_n \end{bmatrix} \quad (17b)$$

A stabilizing control $\tilde{p}(\cdot): \mathbb{R}^n \times \mathbb{R}_+^1 \rightarrow \mathbb{R}^n$, $\xi(t) = \tilde{p}(x(t), t)$ is found from (7)

$$\tilde{p}(x, t) = \begin{cases} -\text{sgn}(x_1 \pi' x) & v(x, t) \notin \mathcal{N} \\ \xi_1 \in \{\xi_1 \in \mathbb{R}^1 : |\xi_1| \leq 1\} & v(x, t) \in \mathcal{N} \end{cases} \quad (18)$$

where π is as in section 5.2. As expected, this result agrees with (14b).

5.4 A Simple Input Disturbance

Let $\dot{x} = Ax + Bu + Bv$, $V = \{v: \|v\| \leq \rho_v = \text{constant}\}$, A, B are constant matrices, and A is asymptotically stable. Choose $U = \{u: \|u\| \leq \rho_u, \rho_u \geq \rho_v\}$. Equation (6) becomes

$$\tilde{p}(x, t) = -\rho_u \frac{B'Px}{\|B'Px\|} \quad V(x, t) \notin \mathcal{N} = \{(x, t): B'Px = 0\}$$

where $PA + A'P + Q = 0$, $Q = Q' > 0$.

Remark 7: Here the origin is not an equilibrium state in the usual sense. Compare with remark 5.

Remark 8: If a system has both input and parameter uncertainty, we sum the corresponding " ρ s."

5.5 An Extension

In the previous sections we assumed that the nominal matrix A is asymptotically stable (i.e., all its eigenvalues have negative real parts). Here we show a way to stabilize A^5 and simultaneously to overcome the uncertainty. Consider the nominally time-invariant linear dynamical system (9)-(12) with $f(x, t) = Ax$, $v \in h + Dw$; that is,

$$\begin{cases} \dot{x} = Ax + B(u + v) \\ x(t_0) = x_0, \quad t \in [t_0, \infty) \\ \|u\| \leq \rho_u(x, t), \quad \|v\| \leq \rho_v(x, t), \end{cases} \quad (19)$$

where A and B are constant matrices. Now consider a control strategy $\tilde{p}(\cdot): \mathbb{R}^n \times \mathbb{R}_+^1 \rightarrow \mathbb{R}^m$ such that

$$\tilde{p}(x, t) = \begin{cases} -L^{-1}B'Px - \rho_u(x, t) \frac{B'Px}{\|B'Px\|} & V(x, t) \notin \mathcal{N} \\ u \in \{u \in \mathbb{R}^m: \|u\| \leq \rho_u(x, t)\} & V(x, t) \in \mathcal{N} \end{cases} \quad (20)$$

where

$$\begin{aligned} \mathcal{N} &= \{(x, t): B'Px = 0\} \\ PA + A'P - PBL^{-1}B'P + Q &= 0, \end{aligned} \quad (20a)$$

L is a constant $m \times m$ p.d. matrix, and Q is a constant $n \times n$ positive semi-definite matrix.

⁵We keep in mind that other methods to stabilize A are available, for example pole placement.

Assumption 6: (F, A, B) , $Q = F'F$, is completely controllable and observable.

Assumption 7: F is an $l \times n$ matrix and $l + m > n$.

Assumption 8: The matrix $[F' | PB]$ has full rank.

Note: If Q is p.d., assumptions 7 and 8 can be dropped.

Theorem 4: Consider the dynamical system (19). Suppose that assumptions 4 and 6-8 are met. Then there exists a control function $\tilde{p}(\cdot): \mathbb{R}^n \times \mathbb{R}^1 \rightarrow \mathbb{R}^m$ satisfying (20) with $\rho_u(x, t) \geq \rho_v(x, t) \quad \forall(x, t)$, where $u(t) = \tilde{p}(\dot{x}(t), t)$, such that the origin $x = \{0\}$ is uniformly asymptotically stable in the large for all admissible disturbances.

Proof: It is similar to the proof of theorem 2 with $v(x, t) = x'Px$ as a Lyapunov function. See also section 5 of reference 19.

Example 3: Consider the system of section 5.2. Using (20) and (14b) we have

$$\tilde{p}(x, t) = [-L^{-1}\pi' + K(\tilde{\eta})]x \quad (21)$$

where

$$K(\tilde{\eta}) = [a_1 \tilde{\eta}_1 \quad \dots \quad a_n \tilde{\eta}_n]$$

$$\tilde{\eta}_i = \begin{cases} -\text{sgn}(x_i \pi' x) & \forall(x, t) \notin \mathcal{N} \\ \eta_i \in \{\eta_i \in \mathbb{R}^1 \mid |\eta_i| \leq 1\} & \forall(x, t) \in \mathcal{N} \end{cases} \quad (21a)$$

$\mathcal{N} = \{(x, t) : \pi'x = 0\}$, π is the n -th column of P , $PA + A'P - PBL^{-1}B'P + Q = 0$; $Q = Q'$, $L = L'$ are p.d.

Example 4: Let $x \in \mathbb{R}^2$ with

$$\dot{x} = \begin{bmatrix} 0 & 1 \\ \Delta a_1 & \Delta a_2 \end{bmatrix} x + \begin{bmatrix} 0 \\ 1 \end{bmatrix} u$$

where $\Delta a_i = \alpha_i v_i$; $|v_i| \leq 1$, $i = 1, 2$. Here

$$A = \begin{bmatrix} 0 & 1 \\ 0 & 0 \end{bmatrix}.$$

Choose

$$L = 1, \quad Q = \begin{bmatrix} q & 0 \\ 0 & 0 \end{bmatrix}, \quad q > 0.$$

Then, by (21a),

$$P = \begin{bmatrix} \sqrt{2q\sqrt{q}} & \sqrt{q} \\ \sqrt{q} & \sqrt{2\sqrt{q}} \end{bmatrix};$$

thus

$$[F' | PB] = \begin{bmatrix} \sqrt{q} & \sqrt{q} \\ 0 & \sqrt{2\sqrt{q}} \end{bmatrix}.$$

It is evident that assumptions 6-8 are met.

We further choose $q = 4$. Using (21) we find

$$x \in D_1: \tilde{p}(x, t) = -[2 - \alpha_1 | 2 + \alpha_2] \begin{bmatrix} x_1 \\ \dots \\ x_2 \end{bmatrix},$$

$$x \in D_2: \tilde{p}(x, t) = -[2 + \alpha_1 | 2 + \alpha_2] \begin{bmatrix} x_1 \\ \dots \\ x_2 \end{bmatrix}$$

$$x \in D_3: \tilde{p}(x, t) = -[2 + \alpha_1 | 2 - \alpha_2] \begin{bmatrix} x_1 \\ \dots \\ x_2 \end{bmatrix}$$

where $\{D_1, D_2, D_3\}$ is defined in figure 2, and the slope of $\{x: \pi'x = 0\}$ is 1.

6. MODEL REFERENCE CONTROL IN THE PRESENCE OF UNCERTAINTY

In many applications it is convenient to have a given system follow an ideal model from an input-output point of view. Suppose a nonlinear system has parameter uncertainty and we wish it to follow its nominal response. Following the usual scheme of "model reference control," we write the equations of the system (plant) and the model, respectively, as

$$\begin{aligned} \dot{x}_p &= f(x_p, t) + \delta f(x_p, t, v) + B(u + r) \\ \dot{x}_m &= Gx_m + f(x_p, t) - Gx_p + Br \end{aligned} \tag{22}$$

where r is a reference signal, $B \in \mathbb{R}^{n \times m}$ is constant, and $G \in \mathbb{R}^{n \times n}$ is any constant matrix with all its eigenvalues in the left half plane. Let $e = x_p - x_m$. Then

$$\dot{e} = Ge + \delta f(x_p, t, v) + Bu \tag{23}$$

If "matching conditions" (11) are satisfied, equation (23) reduces to the form of (12), and theorem 2 is applicable. The block diagram for this situation is given in figure 3, with the choice $G = -\alpha I$ and $Q = \beta I$.

Remark 9: Note that as $e \rightarrow 0$, the model description approaches the desired nominal system

$$\dot{x}_m = f(x_m, t) + Br \quad (24)$$

Remark 10: Since, in general, x_p does not approach zero, the origin $e = \{0\}$ in (23) with the feedback control shown in figure 3 is not an equilibrium state in the usual sense. (Compare with remarks 5 and 7.)

Remark 11: In the light of (24), it is possible to design the model using any convenient method, and then to use an additional feedback to overcome the uncertainty.

Remark 12: Finally note that the "Variable Structure Model" in (22) permits us to drop the necessity to know the Lyapunov function $v(\cdot)$ in assumption 3.

CONCLUSIONS

In this paper some results from the theory of differential games and Lyapunov stability of generalized dynamical systems are combined to produce simple results concerning a class of uncertain dynamical systems. The basic assumption on the system's structure is the "matching condition" which is common in adoptive schemes as well. The basic feature of the present approach is the possibility to steer a system asymptotically to its nominal behavior against any bounded uncertainty. The extension of this theory to systems with incomplete state measurement is left for a future investigation.

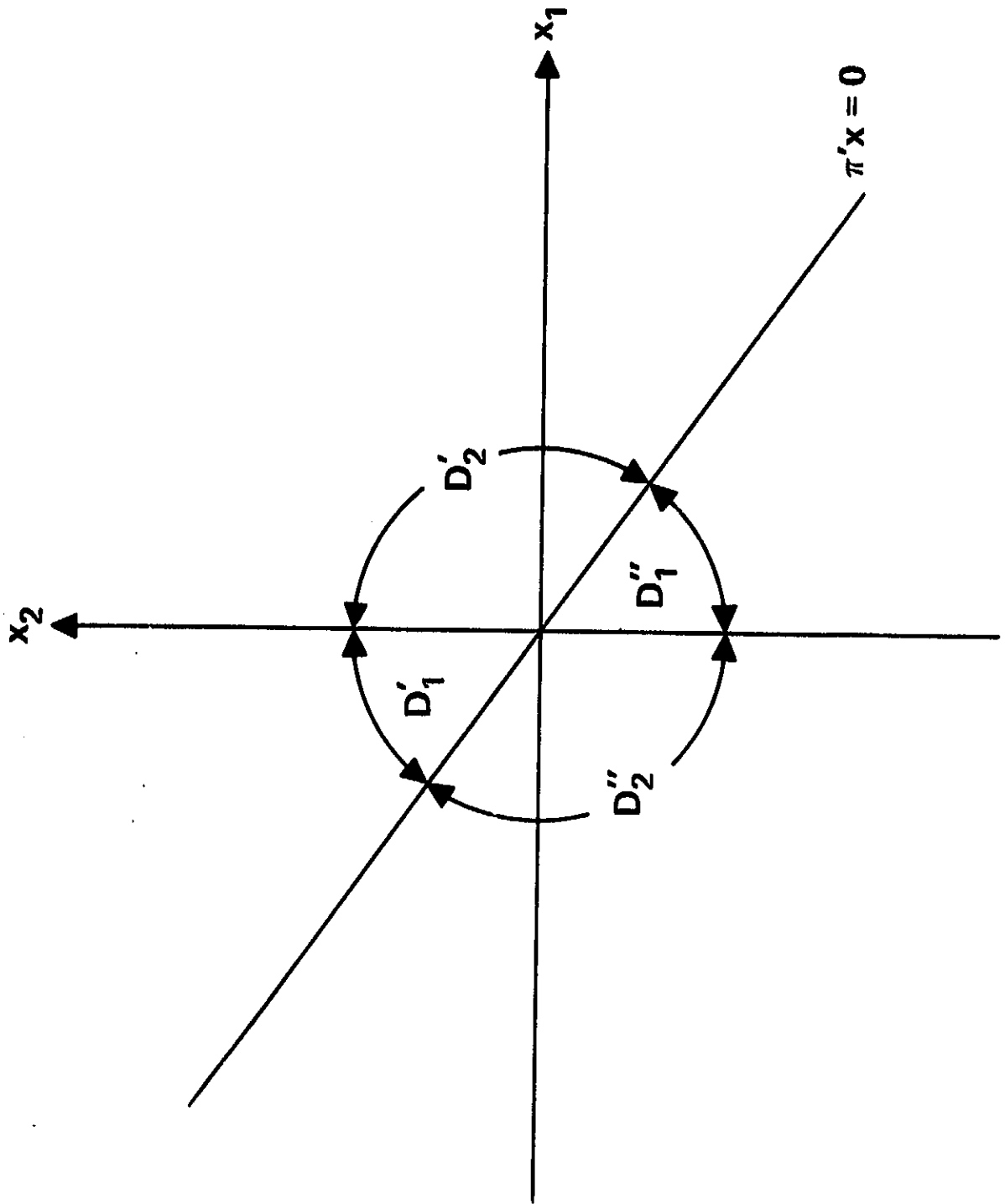

Figure 1.- Example 1.

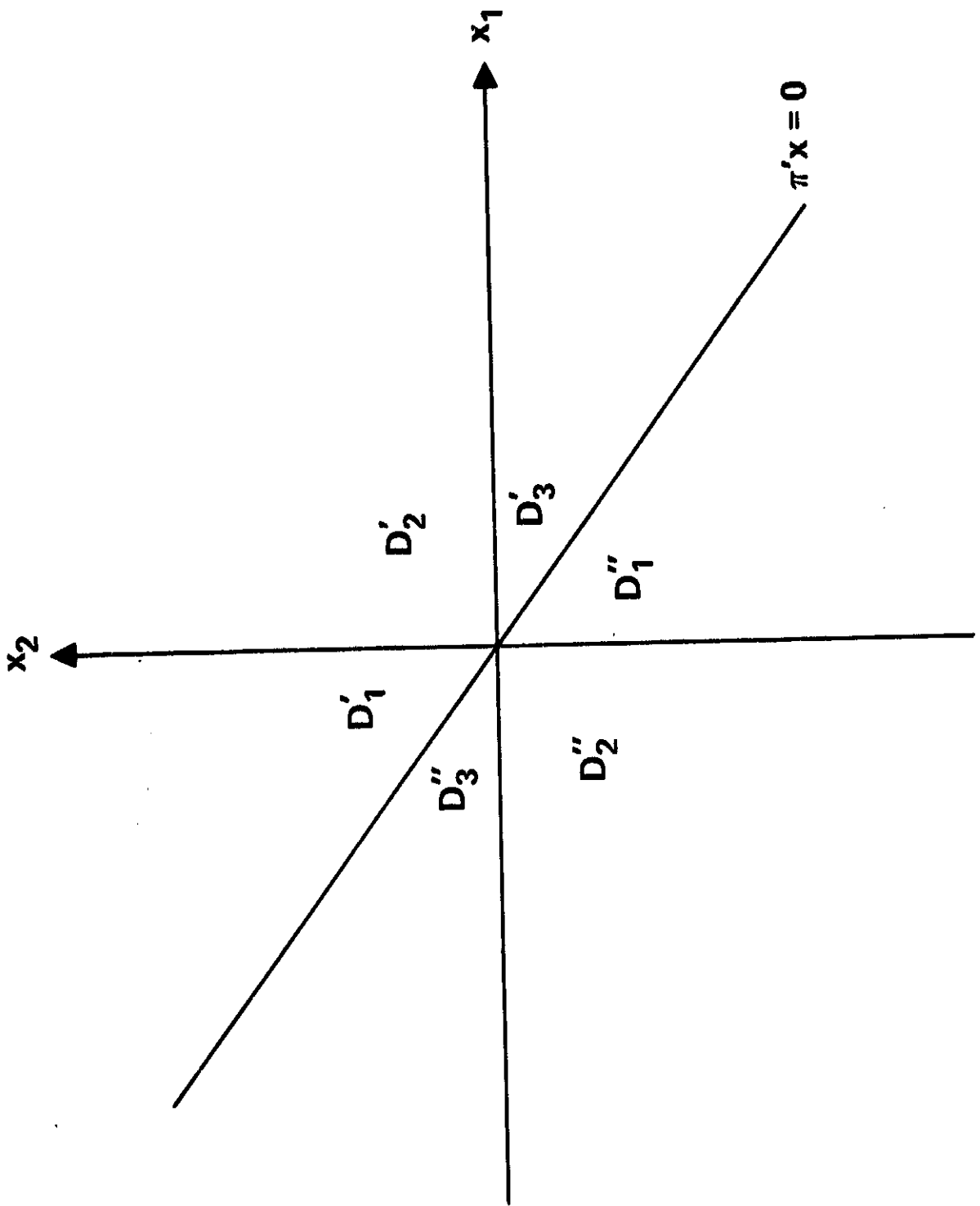

Figure 2.- Example 2.

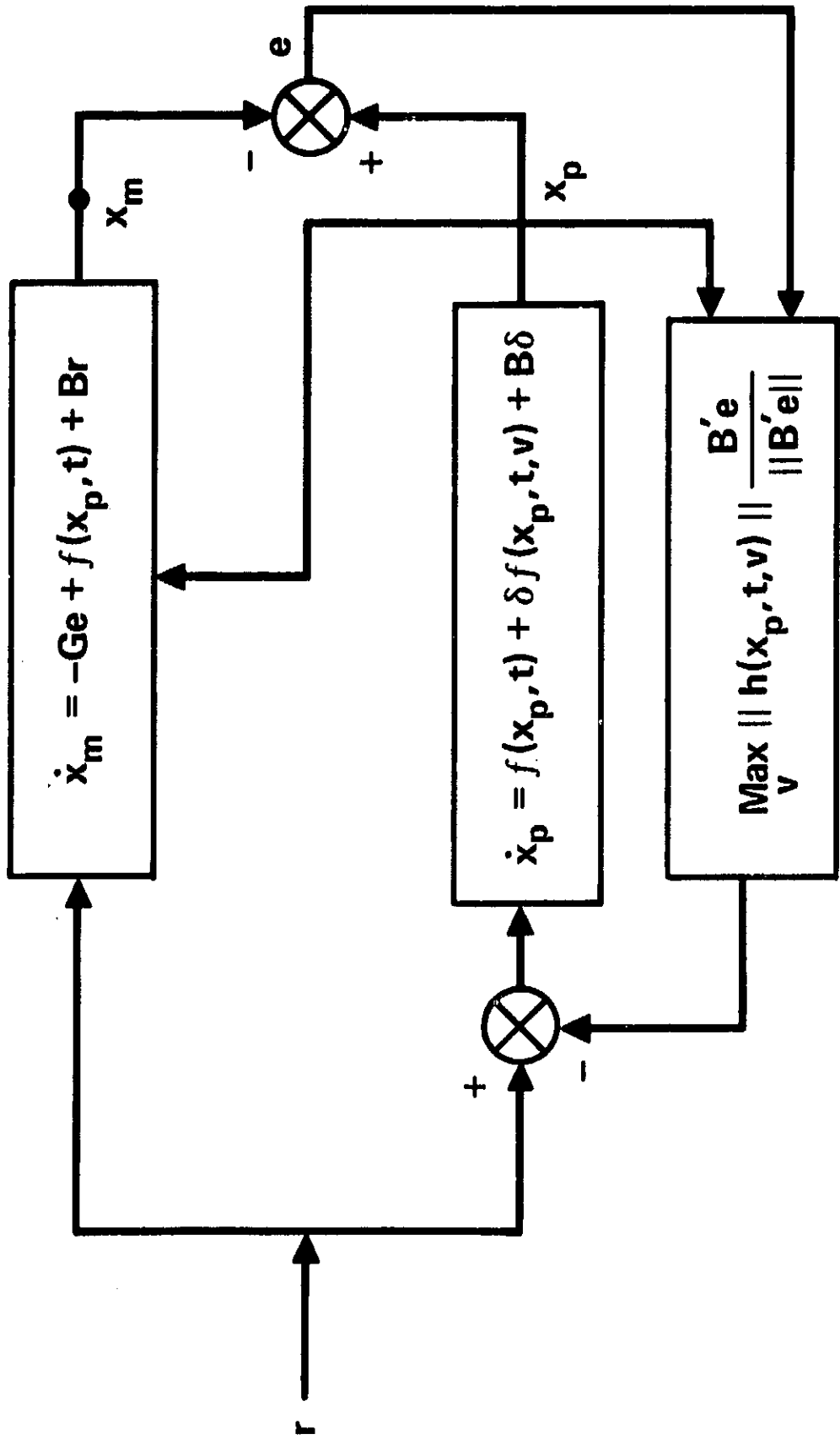

Figure 3.- Model reference scheme.

APPENDIX

DIFFERENTIAL EQUATIONS WITH DISCONTINUOUS R.H.S.

A.1 Some Results from the Theory of "Generalized Dynamical Systems," (Ref. 11)

Definition 1: The *distance* between a point $x \in \mathbb{R}^n$ and a set $A \in \mathbb{R}^n$ is defined by

$$d(x, A) = \inf\{\|x - a\| : a \in A\}$$

Definition 2: The *separation* of set A from set B is defined by

$$d^*(A, B) = \sup\{d(a, B) : a \in A\}$$

Definition 3: The variable set $E(\alpha) \subset \mathbb{R}^n$, $\alpha \in \mathbb{R}^n \times \mathbb{R}^1$, is said to be *upper semi-continuous* at α_0 , if for every $\delta > 0$ there exists some neighborhood $\bar{N}(\alpha_0)$ of α_0 such that $\forall \alpha \in \bar{N}(\alpha_0)$

$$d^*(E(\alpha), E(\alpha_0)) < \delta$$

In other words, $E(\cdot)$ is upper semicontinuous at a point, if its separation is continuous there.

Definition 4: Let $c = \{x(t) : x : [t', t''] \rightarrow \mathbb{R}^n\}$ be a curve defined on $[t', t'']$. Let

$$y(t_1) = \frac{x(t_1) - x(t_0)}{t_1 - t_0}, \quad t_0, t_1 \in [t', t''] .$$

The set of all $y_0 \in \mathbb{R}^n$ such that there exists a sequence $\{t_1\}$, $i = 1, 2, 3, \dots$, $t_1 \rightarrow t_0$, $t_1 \neq t_0$, and $\lim_{i \rightarrow \infty} y(t_1) = y_0$ is called the *contingent derivative* of c at $x(t_0)$; at $x(t)$ it will be designated by $D^*x(t)$.

Definition 5: An expression $D^*x \in E(x, t)$, where the set $E(x, t)$ depends on (x, t) and is defined on $\mathbb{R}^n \times \mathbb{R}_+^1$ is called a *contingent equation*.

Definition 6: A solution of $D^*x \in E(x, t)$ is any curve $c = \{x(t) : x(\cdot) : [t', t''] \rightarrow \mathbb{R}^n\}$ such that

1. $x(\cdot)$ is absolutely continuous
2. $\dot{x}(t) \in E(x(t), t)$ for almost all $t \in [t', t'']$.

Theorem A.1: Let $E(x, t) \subset \mathbb{R}^n$ defined on some compact neighborhood $\bar{N}(x_0, t_0)$ be compact, convex and upper semicontinuous. Then there exists at least one

solution to the above contingent equation, passing through a given point (x_0, t_0) and this solution can be continued until reaching the boundary of $N(x_0, t_0)$.

A.2 Existence of a Solution to Equation (8)

1. Clearly, at a point $(x, t) \in \mathcal{N}$, the set $E(x, t)$ is a point in \mathbb{R}^n , and $E(\cdot)$ is continuous there; thus, the usual existence theorem holds.

2. At a point $(\bar{x}, \bar{t}) \in \mathcal{N}$, (see fig. A-1), convexity and compactness are trivial by construction. To prove upper semicontinuity, let $\phi(\cdot): \mathbb{R}^n \times \mathbb{R}_+^1 \rightarrow \mathbb{R}^n$ be given by

$$\phi(x, t) = f(x, t) + B(x, t)e(x, t)$$

(i) $(x_1, t_1) \notin \mathcal{N}$ (fig. A-1).

Since $E(x_1, t_1)$ is a point in \mathbb{R}^n ,

$$\begin{aligned} d^*(E(x_1, t_1), E(\bar{x}, \bar{t})) &= d(E(x_1, t_1), E(\bar{x}, \bar{t})) \\ &= \inf_{\bar{u} \in U} \|\phi(\bar{x}, \bar{t}) - \phi(x_1, t_1) + B(\bar{x}, \bar{t})\bar{u} \\ &\quad - B(x_1, t_1)\bar{p}(x_1, t_1)\| \\ &\leq \|\phi(\bar{x}, \bar{t}) - \phi(x_1, t_1)\| + \|\rho B(\bar{x}, \bar{t}) - \rho B(x_1, t_1)\| \\ &\triangleq \|\Delta\phi_1\| + \|\rho\Delta B_1\| \end{aligned}$$

(ii) $(x_2, t_2) \in \mathcal{N}$ (fig. A-1).

$$\begin{aligned} d^*(E(x_2, t_2), E(\bar{x}, \bar{t})) &= \sup_{u_2 \in U} \inf_{\bar{u} \in U} \|\phi(\bar{x}, \bar{t}) - \phi(x_2, t_2) + B(\bar{x}, \bar{t})\bar{u} - B(x_2, t_2)u_2\| \\ &\leq \|\Delta\phi_2\| + \sup_{u_2 \in U} \inf_{\bar{u} \in U} \|B(\bar{x}, \bar{t})\bar{u} - B(x_2, t_2)u_2\| \\ &= \|\Delta\phi_2\| + \sup_{u_2 \in U} \inf_{\bar{u} \in U} \|B(\bar{x}, \bar{t})(\bar{u} - u_2) + \Delta B_2 u_2\| \\ &\leq \|\Delta\phi_2\| + \sup_{u_2 \in U} \inf_{\bar{u} \in U} \left[\|B(\bar{x}, \bar{t})\| \|\bar{u} - u_2\| + \|\Delta B_2\| \|u_2\| \right] \\ &= \|\Delta\phi_2\| + \sup \{ \|\Delta B_2\| \|u_2\| \\ &\quad + \|B(\bar{x}, \bar{t})\| \inf \{ \|\bar{u} - u_2\| : \bar{u} \in U \} : u_2 \in U \} \\ &= \|\Delta\phi_2\| + \|\Delta B_2\| \sup \{ \|u_2\| : u_2 \in U \} \\ &= \|\Delta\phi_2\| + \|\rho\Delta B_2\| \end{aligned}$$

(iii) Since $\rho(\cdot)$, $\phi(\cdot)$ and $B(\cdot)$ are continuous, given any $\delta_1, \tilde{\delta}_1 > 0$, $\exists \epsilon_1, \tilde{\epsilon}_1 > 0$ such that

$$\|(\bar{x}, \bar{t}) - (x_1, t_1)\| < \epsilon_1 \Rightarrow \|\Delta\phi_1\| < \delta_1$$

$$\|(\bar{x}, \bar{t}) - (x_1, t_1)\| < \tilde{\epsilon}_1 \Rightarrow \|\rho\Delta B_1\| < \tilde{\delta}_1.$$

Thus, given any $\delta > 0$ choose any $\delta_1, \tilde{\delta}_1 > 0$ such that $\delta_1 + \tilde{\delta}_1 = \delta$. Then $\exists \epsilon = \text{Min}\{\epsilon_1, \tilde{\epsilon}_1\}$ such that

$$\|(\bar{x}, \bar{t}) - (x_1, t_1)\| < \epsilon \Rightarrow d^*(E(x_1, t_1), E(\bar{x}, \bar{t})) \leq \|\Delta\phi_1\| + \|\rho\Delta B_1\| < \delta_1 + \tilde{\delta}_1 = \delta.$$

A similar result holds for (x_2, t_2) . We conclude that the separation $d^*(\cdot)$ is continuous, which implies that $E(\cdot)$ is upper semicontinuous.

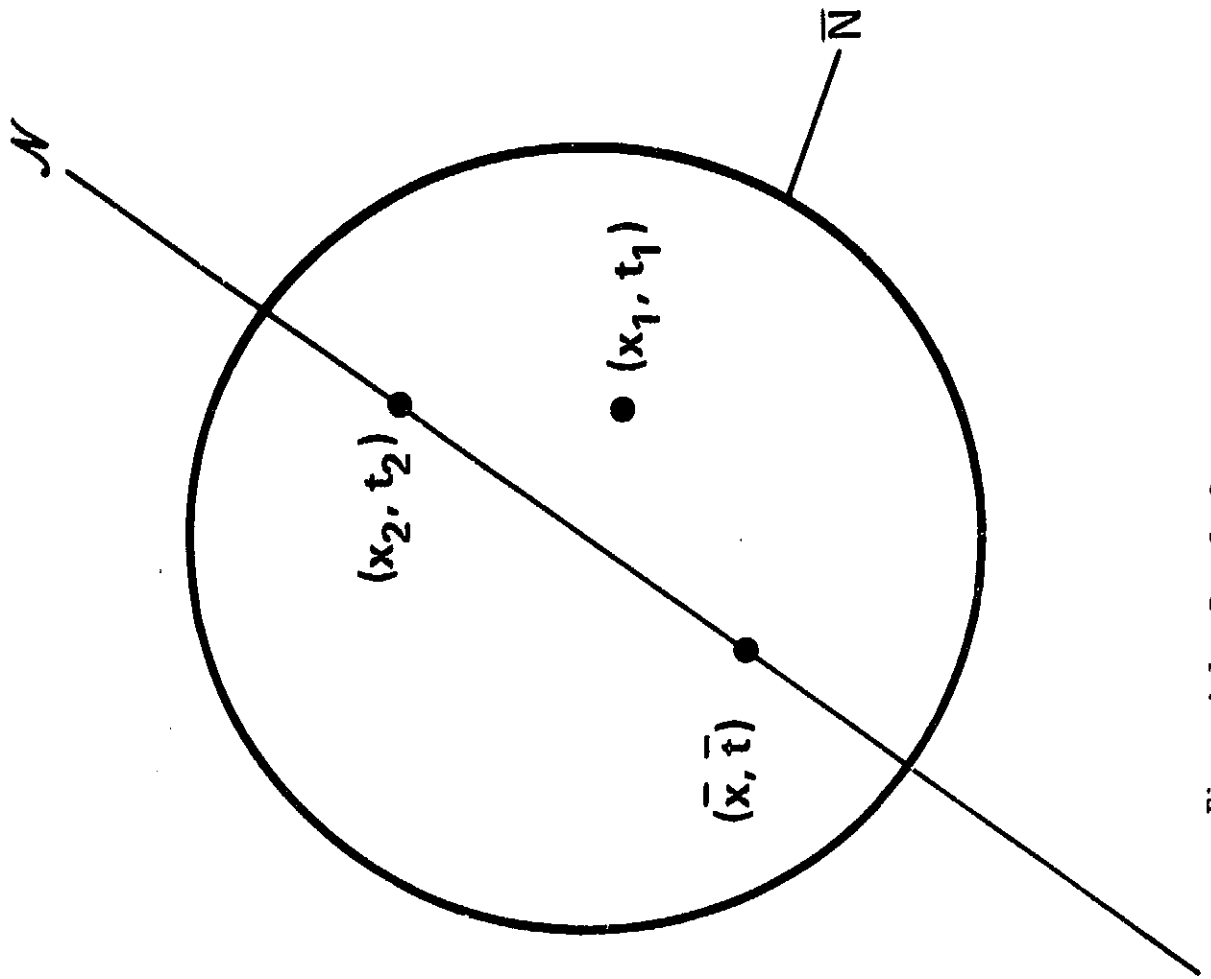

Figure A-1.- Proof of upper semicontinuity.

References

1. Taran, V. A.: Improving the Dynamic Properties of Automatic Control Systems by Means of Nonlinear Corrections and Variable Structure. Automation and Remote Control, vol. 25, January 1964, pp. 140-149.
2. Buyakas, V. I.: Optimal Control by Systems with Variable Structure. Automation and Remote Control, vol. 27, April 1966, pp. 57-68.
3. Bruni, C.; Dipillo, G.; and Koch, G.: Bilinear Systems: An Appealing Class of "Nearly Linear" Systems in Theory and Application. IEEE Trans. on A-C, vol. AC-19, August 1974, pp. 334-348.
4. Drazenovic, B.: The Invariance Conditions in Variable Structure Systems. Automatica, vol. 5, 1969, pp. 287-295.
5. Utkin, V. I.: Sliding Regimes and Their Applications in Variable Structure Systems. Nauka, Moscow, 1974.
6. Chang, S. S. L.; and Peng, T. K. C.: Adaptive Guarantee Cost Control of Systems with Uncertain Parameters. IEEE Trans. on A-C, vol. AC-17, August 1972, pp. 474-483.
7. Narendra, K. S.; and Kudva, P.: Stable Adaptive Schemes for System Identification and Control I. IEEE Trans. on Systems, Man and Cybernetics, vol. SMC-4, November 1974, pp. 542-551.
8. Landau, I. D.; and Courtiol, B.: Design of Multivariable Adaptive Model Following Control Systems. Automatica, vol. 10, 1974, pp. 483-494.
9. Erzberger, H.: On the Use of Algebraic Methods in the Analysis and Design of Model-Following Control Systems. NASA TN D-4663, April 1968.
10. Alimov, Y. I.: On the Application of Lyapunov's Direct Method to Differential Equations with Ambiguous Right Sides. Automation and Remote Control, vol. 22, July 1961, pp. 817-830.
11. Roxin, E.: On Generalized Dynamical Systems Defined by a Contingent Equation. J. Differential Equations, vol. 1, 1965, pp. 188-205.
12. Roxin, E.: On Asymptotic Stability in Control Systems. Rend. Circ. Mat. di Palermo, Serie II, Tomo XV, 1966, pp. 193-208.
13. Utkin, V. I.: Equations of the Slipping Regime in Discontinuous Systems I, II. Automation and Remote Control, vol. 32, Dec. 1971, pp. 42-54, and vol. 33, Feb. 1972, pp. 51-61.
14. Gutman, S.; and Leitmann, G.: Stabilizing Control for Linear Systems with Bounded Parameter and Input Uncertainty. Proc. 7th IFIP Conf. on Optimization Techniques, Nice, Springer Verlag, 1975.

15. Jacobson, D. H.: Stabilization and Optimal Control of Nonlinear Systems Homogeneous in the Input. CSIR Special Report, WISK 170, Pretoria, June 1975.
16. Blaquiere, A.; Gerard, F.; and Leitmann, G.: Quantitative and Qualitative Games. Academic Press, New York, 1969.
17. Isaacs, R.: Differential Games. John Wiley and Sons, New York, 1965.
18. Kalman, R. E.; and Bertram, J. E.: Control System Analysis and Design via the "Second Method" of Lyapunov. J. Basic Engin., ASME Trans., vol. 82, June 1960, pp. 371-393.
19. Gutman, S.; and Leitmann, G.: On a Class of Linear Differential Games. J. of Optimization Theory and Applications., vol. 17, Dec. 1975, pp. 511-522.