

NASA TECHNICAL NOTE



NASA TN D-8249

NASA TN D-8249

CASE FILE
COPY

APOLLO EXPERIENCE REPORT -
GUIDANCE AND CONTROL SYSTEMS

Raymond E. Wilson, Jr.

*Lyndon B. Johnson Space Center
Houston, Texas 77058*



1. Report No. NASA TN D-8249	2. Government Accession No.	3. Recipient's Catalog No.	
4. Title and Subtitle APOLLO EXPERIENCE REPORT GUIDANCE AND CONTROL SYSTEMS		5. Report Date June 1976	
		6. Performing Organization Code JSC-08630	
7. Author(s) Raymond E. Wilson, Jr.		8. Performing Organization Report No. JSC S-418	
		10. Work Unit No. 914-50-00-00-72	
9. Performing Organization Name and Address Lyndon B. Johnson Space Center Houston, Texas 77058		11. Contract or Grant No.	
		13. Type of Report and Period Covered Technical Note	
12. Sponsoring Agency Name and Address National Aeronautics and Space Administration Washington, D.C. 20546		14. Sponsoring Agency Code	
		15. Supplementary Notes	
16. Abstract The Apollo guidance and control systems for both the command module and the lunar module are described in a summary report. General functional requirements are discussed, and general functional descriptions of the various subsystems and their interfaces are provided. The differences between the original in-flight maintenance concept and the final lunar-orbital- rendezvous concept are discussed, and the background in philosophy, the system development, and the reasons for the change in concept are chronologically presented. Block diagrams showing the command module guidance and control system under each concept are included. Significant conclusions and recommendations contained in more detailed reports on specific areas of the guidance and control systems are included.			
17. Key Words (Suggested by Author(s)) <ul style="list-style-type: none"> * Navigation * Stabilization Control * Attitude Control * Reaction Control * Descent Trajectories * Flight Control * Rendezvous * Reentry Guidance * Gyroscopes 		18. Distribution Statement Star Subject Category: 12 (Astronautics, General)	
19. Security Classif. (of this report) Unclassified	20. Security Classif. (of this page) Unclassified	21. No. of Pages 20	22. Price* \$3.50

CONTENTS

Section	Page
SUMMARY	1
INTRODUCTION	1
DESCRIPTION OF SYSTEMS	3
Command and Service Module	3
Lunar Module	9
CONCLUDING REMARKS AND RECOMMENDATIONS	13
REFERENCES	16

FIGURES

Figure		Page
1	Diagram of Block I command module guidance and control system	4
2	Diagram of Block II command module guidance and control system	5
3	Command module primary guidance, navigation, and control system	6
4	Command module stabilization and control system	8
5	Entry monitor system	9
6	The ORDEAL assembly, showing panel and switch positions	9
7	Lunar module guidance and control system configuration diagrams	10
8	Lunar module primary guidance, navigation, and control system	11
9	Lunar module stabilization and control system	12
10	Lunar module abort guidance system	12

APOLLO EXPERIENCE REPORT

GUIDANCE AND CONTROL SYSTEMS

By Raymond E. Wilson, Jr.
Lyndon B. Johnson Space Center

SUMMARY

This report contains general descriptions of the Apollo guidance and control systems for the command module and the lunar module and is the general summary document for a series of more detailed reports on specific areas of the guidance and control systems. The Apollo Block I guidance and control system is briefly described to show the differences between the original in-flight maintenance concept and the final lunar-orbital-rendezvous concept. Even with the in-flight maintenance concept, the reliability of the Block I design was less than that of the Block II design, which incorporated built-in redundancy and alternate modes of operation. The Block II concept includes several unique systems that provide the necessary primary operational functions and the necessary redundancy for backup and abort requirements. Some of the more significant recommendations and conclusions contained in the other Apollo guidance and control system reports are included in this summary report.

INTRODUCTION

The Apollo guidance and control (G&C) systems for the command and service module (CSM) and the lunar module (LM) were designed and qualified to support the 14-day lunar mission. (Information regarding the control of unmanned Apollo missions is given in refs. 1 and 2.) The design of the G&C systems included the following subsystems: the stabilization and control system (SCS); the primary guidance, navigation, and control system (PGNCS); the entry monitor system (EMS); the orbital-rate drive, Earth and lunar (ORDEAL) assembly; the service propulsion system (SPS) gimbal actuators; the mission control programer (used on the Block I command module (CM) unmanned flights); and the abort guidance system (AGS).

The Block I CM design philosophy was based on an in-flight maintenance concept. From early in the Apollo Program until the major Block II CM change in June 1964, the SCS was the primary method of flight control. The initial Apollo proposal indicated that the control system would also encompass a lunar landing capability. This idea, however, was eliminated when the lunar-orbital-rendezvous concept was adopted by NASA. As the primary method of flight control, the Block I system had to meet a standard of high reliability that could be achieved only through the use of in-flight

maintenance. Despite the best efforts of reliability and design engineers, the mean time between failures for the equipment was of the same order of magnitude as the mission time. Hence, the most feasible solution to the problem of maintaining high system reliability was to provide standby redundancy in the form of onboard spares.

At the time the Block II concept was being defined in June 1964, the in-flight maintenance requirement was abandoned. Because the Block I Earth-orbital reliability requirement was considerably less stringent than that for the Block II lunar mission, additional redundant circuits were not added to the Block I vehicle in lieu of onboard spares. Instead, the Block II system was redesigned to include redundant control paths.

The concept of in-flight maintenance was discarded because it proved to be impractical. Although it was technically feasible for the astronaut to detect and replace a defective module, it was not an easy task. For example, in the control system laboratory, experienced and highly trained technicians often required many hours to locate and change a defective element. Furthermore, the changes necessary for meeting a new requirement to withstand much greater humidity made the installation and removal of the modules even more difficult.

In the summer of 1964, the Apollo Program was divided into the Block I and Block II vehicle programs; the difference was that the Block II vehicles would have lunar-mission capability. The underlying concept of this change was that the PGNCs should be considered the primary mode of control and the SCS the backup mode; that is, the SCS was to be used for control when the PGNCs was not used.

The Block II design of built-in redundancy and alternate modes of operational capability has resulted in a G&C system that is more reliable and that weighs less than the Block I system. In addition, the standard connectors used on Block II have been less troublesome than the connectors used on Block I. The problem of single-point failures will limit the reliability of any system. The complexity of space systems produces a maze of failure modes and subtle circuits that are almost impossible to analyze by "brute force" methods. Analysis tools and methods are needed to assist in the total design process and to ensure the operation of the system.

The initial concept and configuration of the LM G&C system evolved during 1963 and 1964. The initial concept was that the Government-furnished primary guidance system would provide the necessary guidance and navigation (G&N) functions and the contractor-furnished SCS would provide the vehicle stabilization and control functions. In addition, the SCS was to provide a backup guidance capability sufficient to permit insertion into a safe lunar orbit if primary guidance were lost.

By mid-1964, the stabilization and control functions had become fairly well defined, and design-control specifications had been completed and subcontracts awarded for most assemblies. During the fall and winter of 1964, NASA (with contractor participation) reviewed the LM G&C requirements and the hardware capabilities of the primary guidance system and the SCS. This review resulted in implementation of the integrated G&C concept. In addition, the backup or abort guidance requirements proved to be more complex than originally envisioned.

The LM G&C system includes two partial paths or systems for vehicle guidance and control. The PGNCS provides the necessary G&C capability for mission completion. The AGS provides the necessary G&C capability for mission abort in the event of PGNCS failure, but does not provide a mission completion capability. Such a capability would have required a backup system having the same capability as the PGNCS and was prohibitive in cost, weight, and power. The SCS forms an integral part of both the primary and abort systems. As part of the primary system, the SCS includes the drivers for reaction control system (RCS) jet operation; the electronic interface for descent-engine thrust and gimbal control; and the hand controllers for manual-attitude, descent-thrust, and translational input commands. In the abort system, the SCS provides jet-select logic, signal summing, and gain control, and the hand controllers used for manual input commands are the same as those used in the primary system. Attitude reference or steering errors are provided to the SCS by the AGS.

The development of the PGNCS digital autopilot is described in reference 3. The development of the G&C hybrid simulation facility by the LM contractor is described in reference 4.

DESCRIPTION OF SYSTEMS

The CSM and LM G&C systems are described in the following paragraphs.

Command and Service Module

A brief functional description of the CSM G&C systems follows. The relationship of the SCS and the PGNCS for the Block I and Block II vehicles is shown in figures 1 and 2, respectively.

The PGNCS is Government-furnished equipment (GFE) and is common to both the CSM and the LM except for differences in the optics, minor differences in the inertial measurement unit (IMU) (accelerometer scaling and location of accelerometer electronics components), and differences in the computer software programming. These differences are described in greater detail in reference 5. The PGNCS is divided into three major subsystems — inertial, optical, and computer — and designed so that each subsystem can be operated independently during an emergency or backup mode. Therefore, the failure of one subsystem will not disable the entire PGNCS. The three subsystems, or combinations of them, can perform the following functions.

1. Periodically establish an inertial reference used for measurements and computations
2. Calculate the position and velocity of the spacecraft by optical navigation and inertial guidance
3. Generate steering signals and calculate targeting data and thrust commands necessary to maintain the required spacecraft trajectory
4. Provide the astronaut with a data display that indicates the status of the G&N

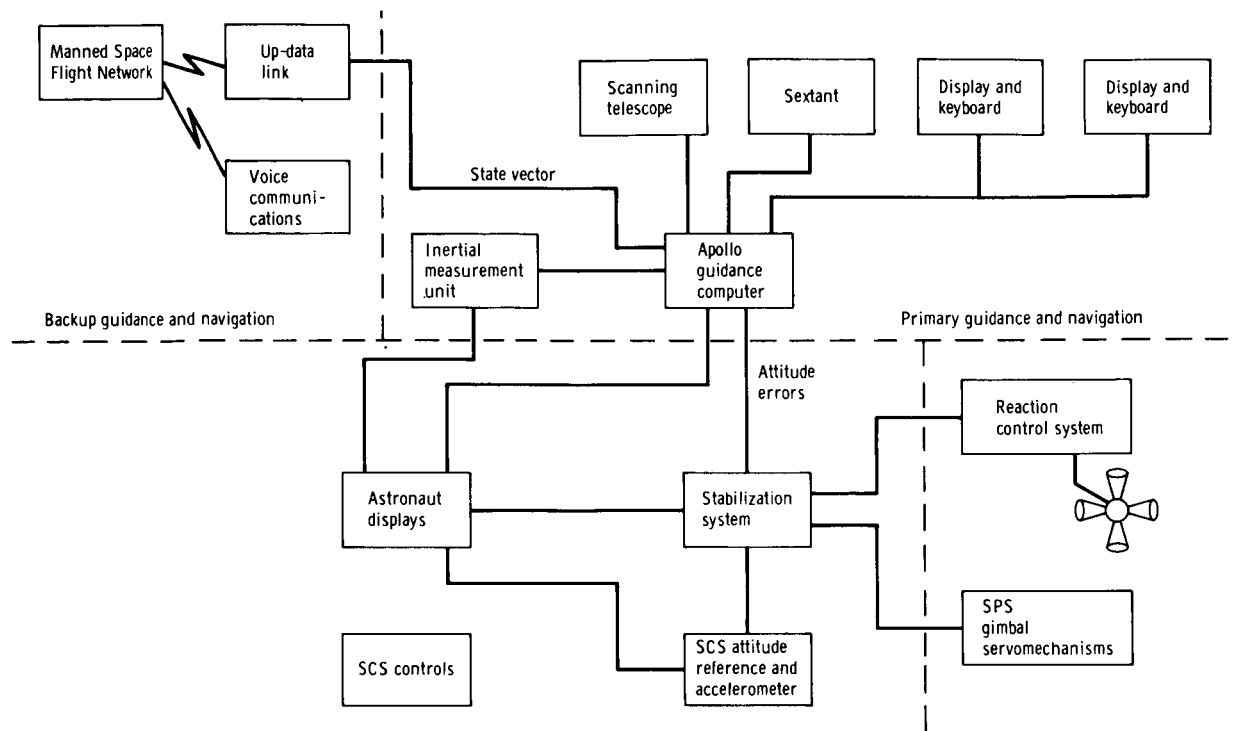

Figure 1. - Diagram of Block I command module guidance and control system.

The PGNCS equipment (fig. 3 and refs. 5 and 6) consists of a navigation base, an IMU, an optical assembly, a power and servo assembly (PSA), an Apollo CM computer (CMC), display and control panels, and an electronic coupling data unit. The navigation base is mounted to the spacecraft sidewall and is used as a holding fixture for the IMU and the optical assembly. The IMU and the optical assembly are attached to and precisely aligned with the navigation base. The display and control panels comprise the front of the G&N structure and are located so that an astronaut can view and manually operate them. The PSA is located on a shelf below the navigation base. The electronic coupling data unit and the CMC are located on a shelf below the PSA. Two display and keyboard (DSKY) units are located in the vehicle, one at the main panel and the other in the lower equipment bay. The DSKY provides access to the CMC and furnishes status information to the astronauts.

The inertial subsystem (ISS) consists of the IMU, the electronic coupling data unit, and portions of the PSA and the display and control panels. The ISS measures changes in spacecraft attitude, assists in generating steering commands, and measures spacecraft velocity changes. The IMU provides an inertial reference consisting of a stable member gimballed for three degrees of freedom and stabilized by signals from three integrating gyros. Acceleration of the spacecraft is sensed by three pendulous accelerometers mounted on the stable member and having orthogonal input axes. The resultant signals from the accelerometers are supplied to the CMC, which then calculates the total velocity. The modes of operation of the ISS can be initiated either automatically by the CMC or manually by the astronaut.

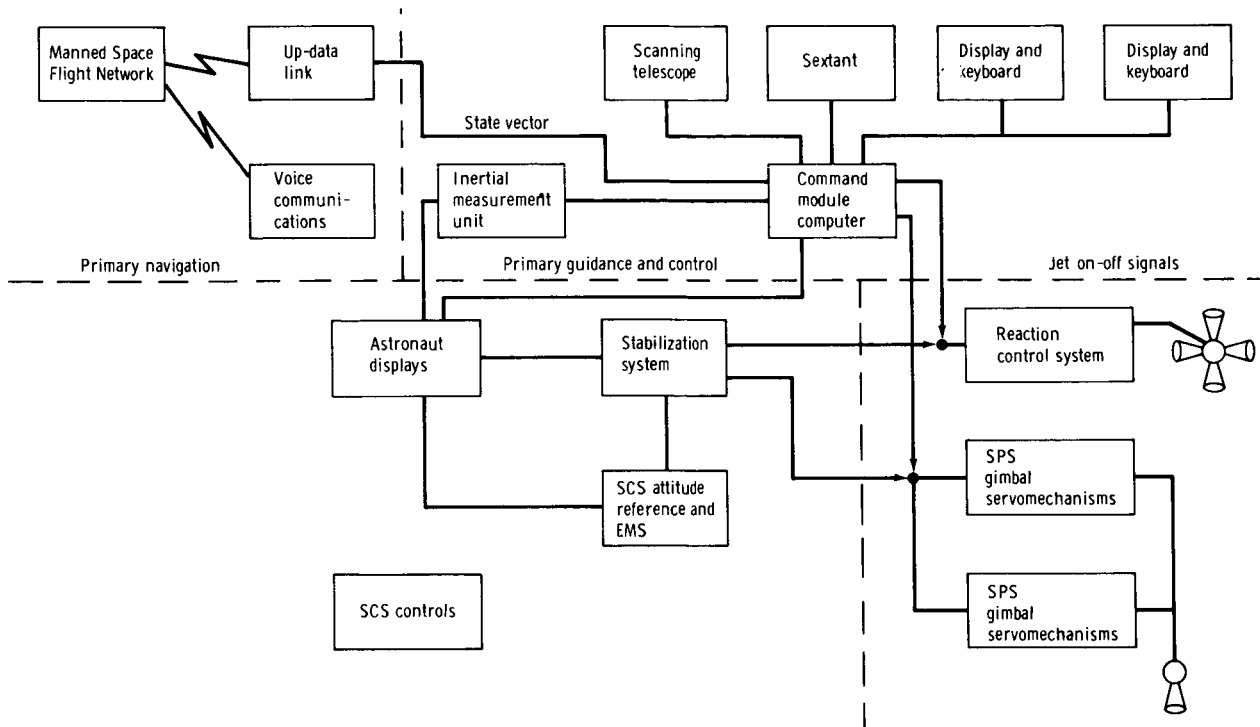

Figure 2. - Diagram of Block II command module guidance and control system.

The optical subsystem (OSS) consists of a sextant and telescope, the electronic coupling data unit, and portions of the PSA and the display and control panels. The OSS provides the CMC with data obtained by measuring angles between lines of sight to celestial objects and provides measurements for establishing the inertial reference. The sextant is a high-magnification (28 \times), dual-line-of-sight device used for precise angular measurements. The telescope has a wide field of view and one line of sight and is used for coarse acquisition or orbital tracking of landmarks. A manual control stick is manipulated to position the optical lines of sight. A manually initiated timing mark causes the CMC to record both the angle and the time at the instant the sextant is properly pointed for a measurement.

The computer subsystem consists of the CMC and portions of the display and control panels. The CMC, which is used to perform space-flight data handling and computations, is a general-purpose digital computer consisting of a core memory, parallel operations, and a built-in self-check capability. Programs stored in the CMC are selected to control and solve flight equations. The selection of the programs can be controlled either manually or by automatic sequencing. The computer subsystem calculates the steering signals and the engine discrete commands necessary to keep the spacecraft on a required trajectory, positions the stable member in the IMU to a coordinate system defined by precise optical measurements, performs limited malfunction isolation, and supplies pertinent spacecraft-condition information to the display and control panels.

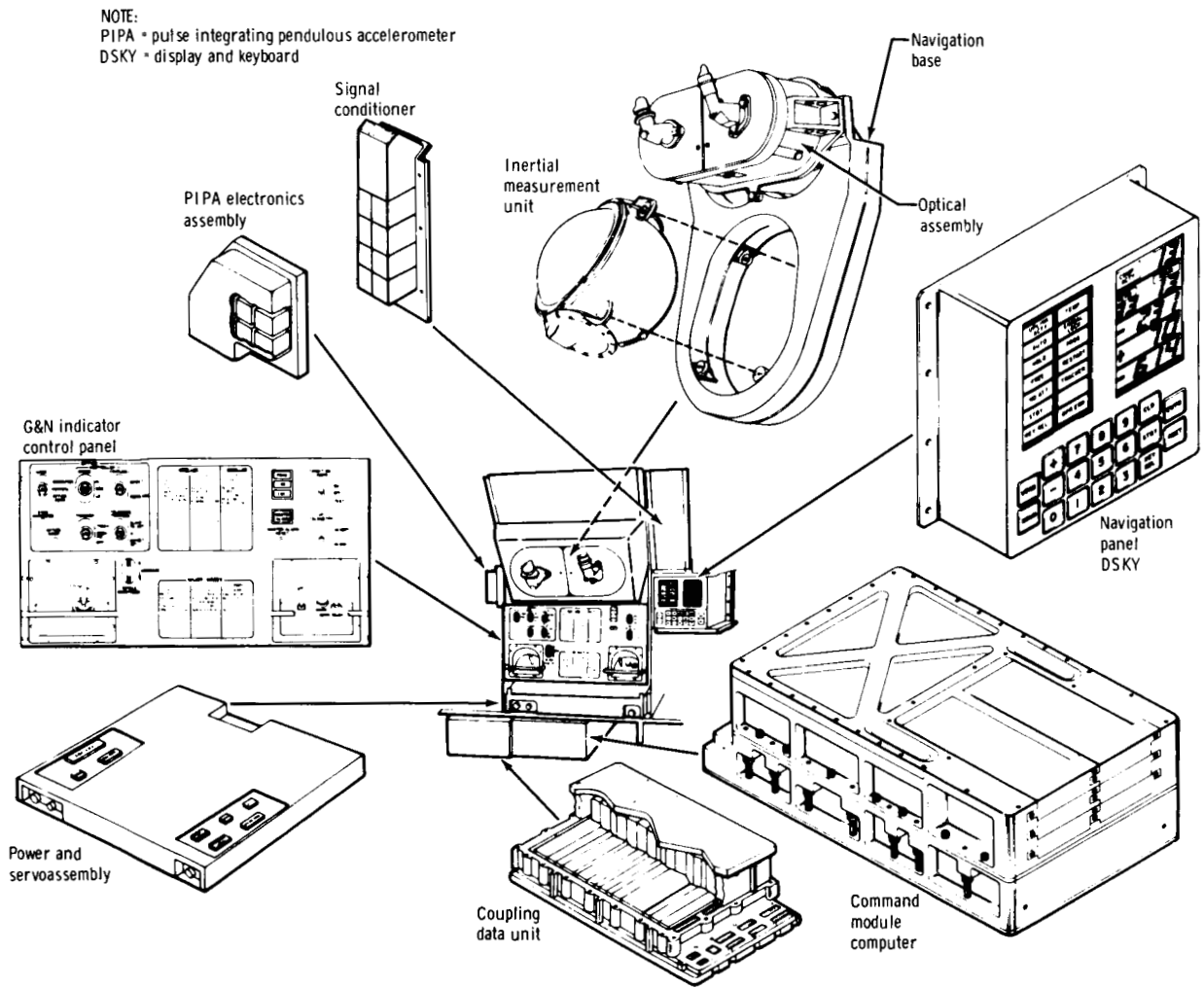

Figure 3. - Command module primary guidance, navigation, and control system.

The SCS (fig. 4 and ref. 7) provides (to the PGNCS) backup stabilization and control of the spacecraft for rotational, translational, and SPS thrusting, using the CSM RCS and SPS-engine gimbal servomechanisms. The SCS also provides the displays and controls required for crew interface. The SCS is divided into three basic subsystems: attitude reference, attitude control, and thrust-vector control. The subsystems contain the elements that provide selectable functions for display, automatic and manual attitude control, and thrust-vector control. The components and functions of the SCS hardware are as follows.

1. The reaction-jet and engine on-off control contain the solenoid drivers and the logic circuits necessary to control the reaction-jet automatic solenoid coils and the SPS-engine solenoid control valves and relays.

2. The electronic control assembly contains the circuit elements required for summing, shaping, and switching the rate and attitude-error signals and the manual

input signals necessary to maintain backup stabilization and control in all axes for thrust-vector and attitude control.

3. The electronic display assembly provides the logic circuits for establishing the signal sources to be displayed and the displays to be used.
4. The gyro displays coupler provides the interface between the body rate sensors and displays to give an accurate readout of spacecraft attitude relative to a given reference coordinate system.
5. The thrust-vector position servoamplifier provides the electrical interfaces between the command electronics and the gimbal actuator for positioning the SPS engine.
6. Each of the two gyro assemblies contains three sensing elements, body-mounted attitude gyros, and the electronics components necessary to provide output signals proportional to angular rate or to angular displacement for each of the three body axes.
7. Two flight director attitude indicators display spacecraft attitude, attitude-error, and angular rate information to the crewmen.
8. The gimbal position and fuel-pressure indicator provides a redundant display of the SPS-engine pitch and yaw gimbal angles and a means of introducing manual trim of the engine gimbals. The indicator has the alternate capability for providing a display of Saturn II and Saturn IV-B fuel and oxidizer pressures.
9. The attitude-set control panel provides a means of manually establishing an attitude reference coordinate system and a visual readout of the coordinates commanded.
10. The translational controller provides a means of exercising manual control over rectilinear motion of the spacecraft in both directions along the three principal body axes. The translational controller also provides the capability for manual abort initiation during launch by counterclockwise rotation and for transfer of spacecraft control from the PGNCS to the SCS by clockwise rotation.
11. Two rotational controllers provide a means of exercising manual control of spacecraft rotation in either direction about the three main axes and provides for manual thrust-vector control in the pitch and yaw axes.

The EMS (fig. 5 and ref. 8) provides information that enables the crewmen to monitor the PGNCS-controlled entry performance and velocity changes, to provide thrust termination signals under SCS-controlled velocity changes, to manually control entry if the PGNCS fails, and to display very-high-frequency ranging information obtained between the undocked CM and LM. The system includes both hardware and software. The software aspects refer to the generation of flight-pattern limit lines. The EMS consists of two basic assemblies: the entry monitor control assembly (EMCA) and the entry monitor scroll assembly (EMSA). The EMCA contains the electronics components and is made up of integrated circuits, a range indicator, an accelerometer, the velocity-change/range-to-go counter logic, a pulse scaler, power supplies, and switches. The EMSA or load-factor/velocity (g-V) plotter assembly consists of a scroll of Mylar tape or film imprinted with g-onset, g-offset, and range potential lines.

The EMS display comprises four functional components essential to trajectory monitoring and flight control: the roll attitude indicator, the entry threshold indicator, the corridor verification indicator, and the flight monitor or scroll.

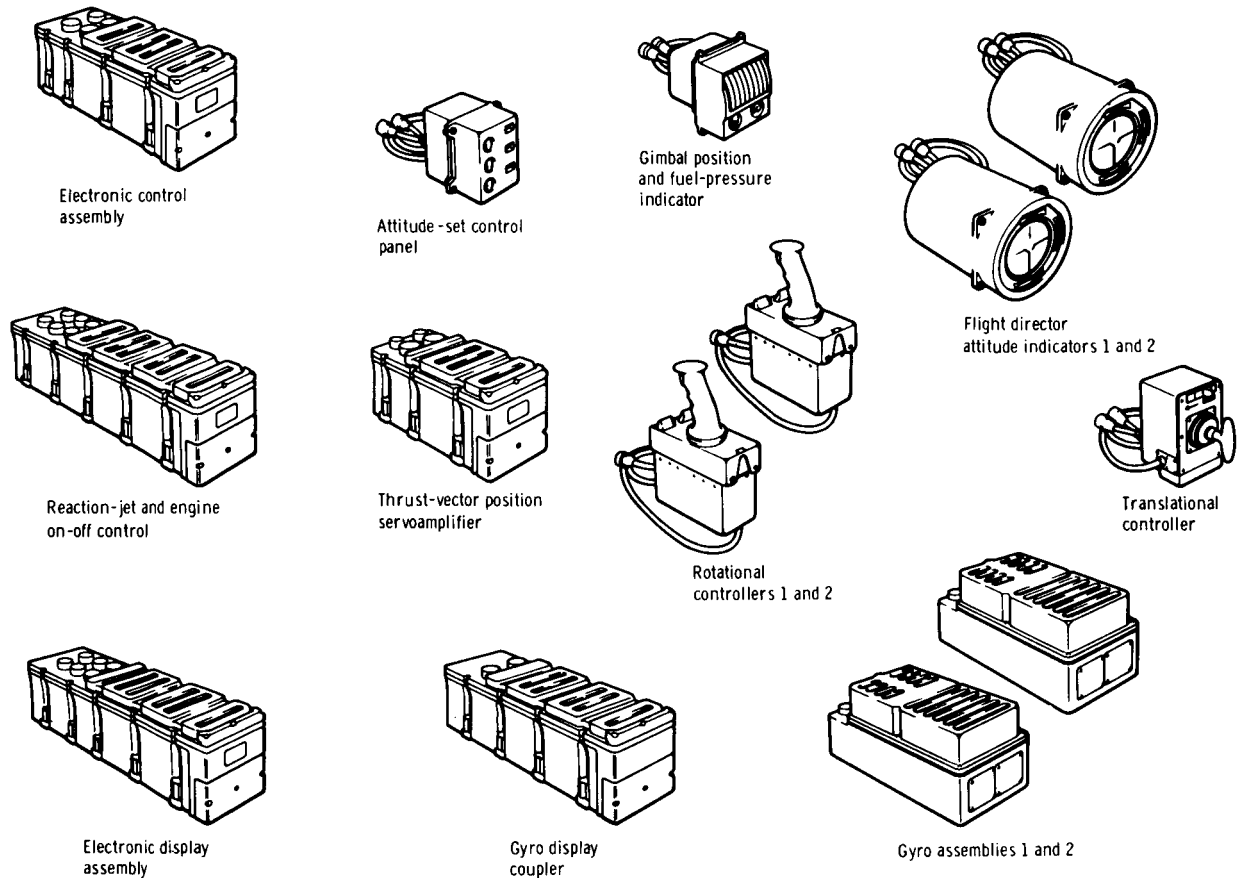

Figure 4. - Command module stabilization and control system.

The roll attitude indicator displays the angular position of the lift vector about the relative wind vector of the vehicle. The entry threshold indicator is a lamp that illuminates when the vehicle encounters a threshold aerodynamic acceleration level, normally an acceleration load factor of 0.05g. The corridor verification indicator consists of two lamps, one of which illuminates at a prescribed time (normally 10 seconds) after the entry threshold is reached. The particular lamp illuminated depends on the measured acceleration level. The flight monitor or scroll is the major component and provides a rectilinear presentation of the entry-acceleration load factor (g) as a function of inertial velocity (V). The display is created with a Mylar tape that has a monitoring pattern printed on the format and an emulsion bonded on the back. The vertical axis is driven in proportion to the acceleration load factor. A scribe removes the emulsion to create the entry trajectory g-V trace as the tape translates horizontally; the flight crew then compares the trace to the permanently displayed monitoring pattern.

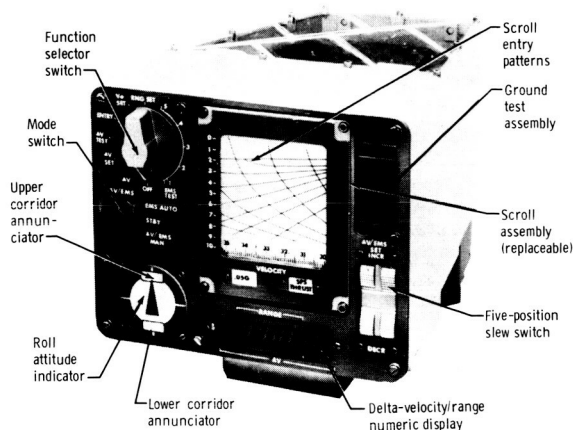

Figure 5. - Entry monitor system.

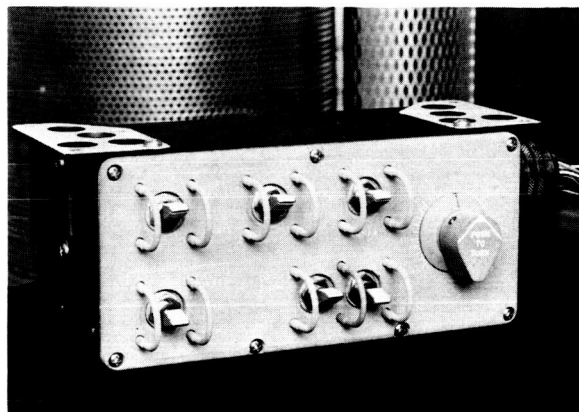

Figure 6. - The ORDEAL assembly, showing panel and switch positions.

The ORDEAL (fig. 6 and ref. 9) is a device that can be switched directly into the FDAI total-attitude circuits to perform a coordinate transformation of spacecraft pitch from an inertial to a local-vertical reference frame. The ORDEAL assembly is supplied as GFE and is common to both the CM and the LM. When the spacecraft panel switches are in the orbital-rate position, sines and cosines of the pitch angle are applied as inputs to a pair of resolvers in the ORDEAL electromechanical module. When the spacecraft panel switches are in the normal position, the ORDEAL is bypassed and the indicators display pitch attitudes to the inertial frame of reference.

Lunar Module

A brief functional description of the LM G&C system follows. The functional relationship between the systems that make up the G&C system is shown in figure 7.

The PGNCs (fig. 8) serves as the autopilot in controlling the LM throughout the mission. Normal guidance requirements include transferring the LM from a lunar orbit to the descent profile, achieving a successful landing at a preselected or crew-selected site, and performing a powered ascent and rendezvous maneuver that results in terminal rendezvous with the CSM. If the mission is to be aborted, the PGNCs performs guidance maneuvers that place the LM in a parking orbit or in a trajectory that intercepts the CSM trajectory. The LM mission programmer is described in reference 10.

The PGNCs includes three major subsystems: inertial, optical, and computer. The ISS establishes the inertial reference frame that is used as the central coordinate system from which all measurements and computations are made. The ISS measures attitude and incremental velocity changes and assists in converting data for computer use, onboard display, or telemetry. Operation is started automatically by the guidance computer or by an astronaut using the computer keyboard. Once the system is energized and aligned to the inertial reference, any LM rotation is sensed by the stable member. The alignment optical telescope, a unity-power, periscope-type device with a

60° conical field of view, is operated manually by the astronauts, and data are read out and manually inserted into the computer through the DSKY. This feature is the major difference between the CSM PGNCS and the LM PGNCS.

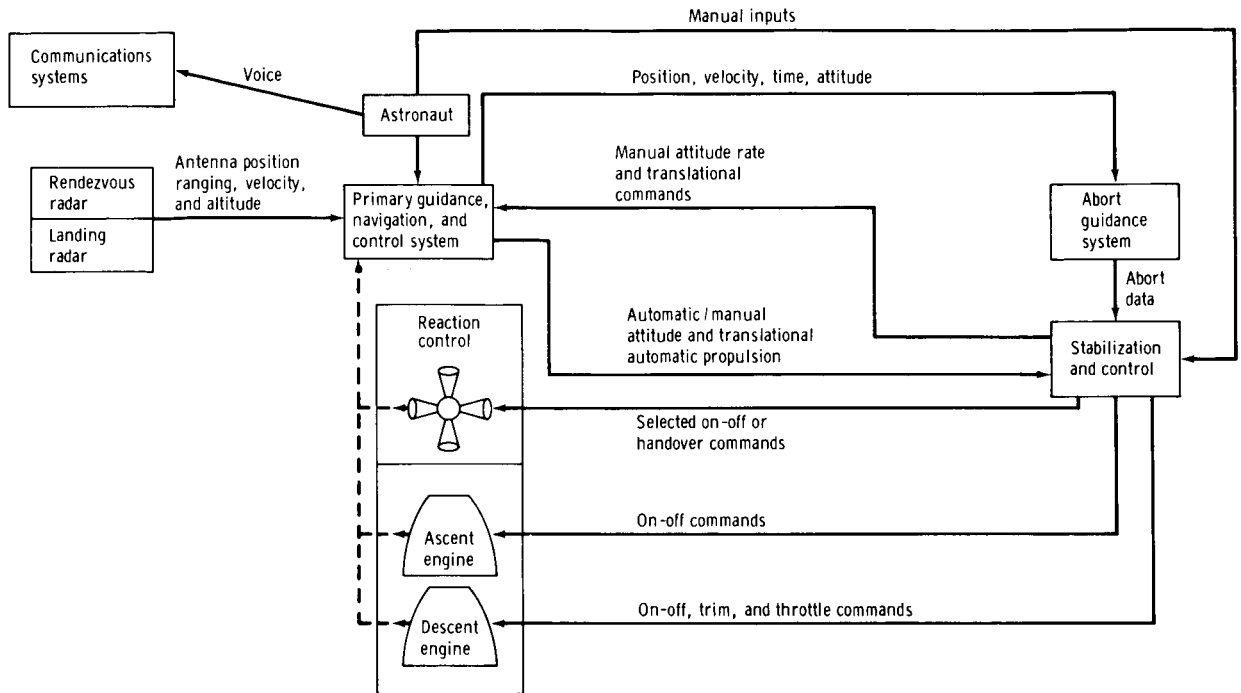

Figure 7. - Lunar module guidance and control system configuration diagrams.

The computer system, as the control and data-processing center of the LM, enables all the G&N functions necessary for automatic control of the path and attitude of the vehicle. The LM computer is identical to the CSM computer except for the absence of stored programs.

The SCS processes RCS and main propulsion system control signals for vehicle stabilization and control (fig. 9 and ref. 11). To stabilize the LM during all phases of the mission, the SCS provides signals that fire proper combinations of 16 RCS thrusters. These signals control attitude and translation about or along all axes; data inputs originate from either the PGNCS or the AGS. The SCS also processes on and off commands for the ascent and descent engines and routes automatic and manual throttle commands to the descent engine. Trim control of the gimballed descent engine is also provided by means of gimbal drive actuators, to ensure that the thrust vector passes through the LM center of gravity. The SCS consists of two attitude controller assemblies (ACA), two thrust and translation controller assemblies (TTCA), an attitude and translation control assembly (ATCA), a rate gyro assembly (RGA), gimbal drive actuator (GDA), and a descent-engine control assembly (DECA).

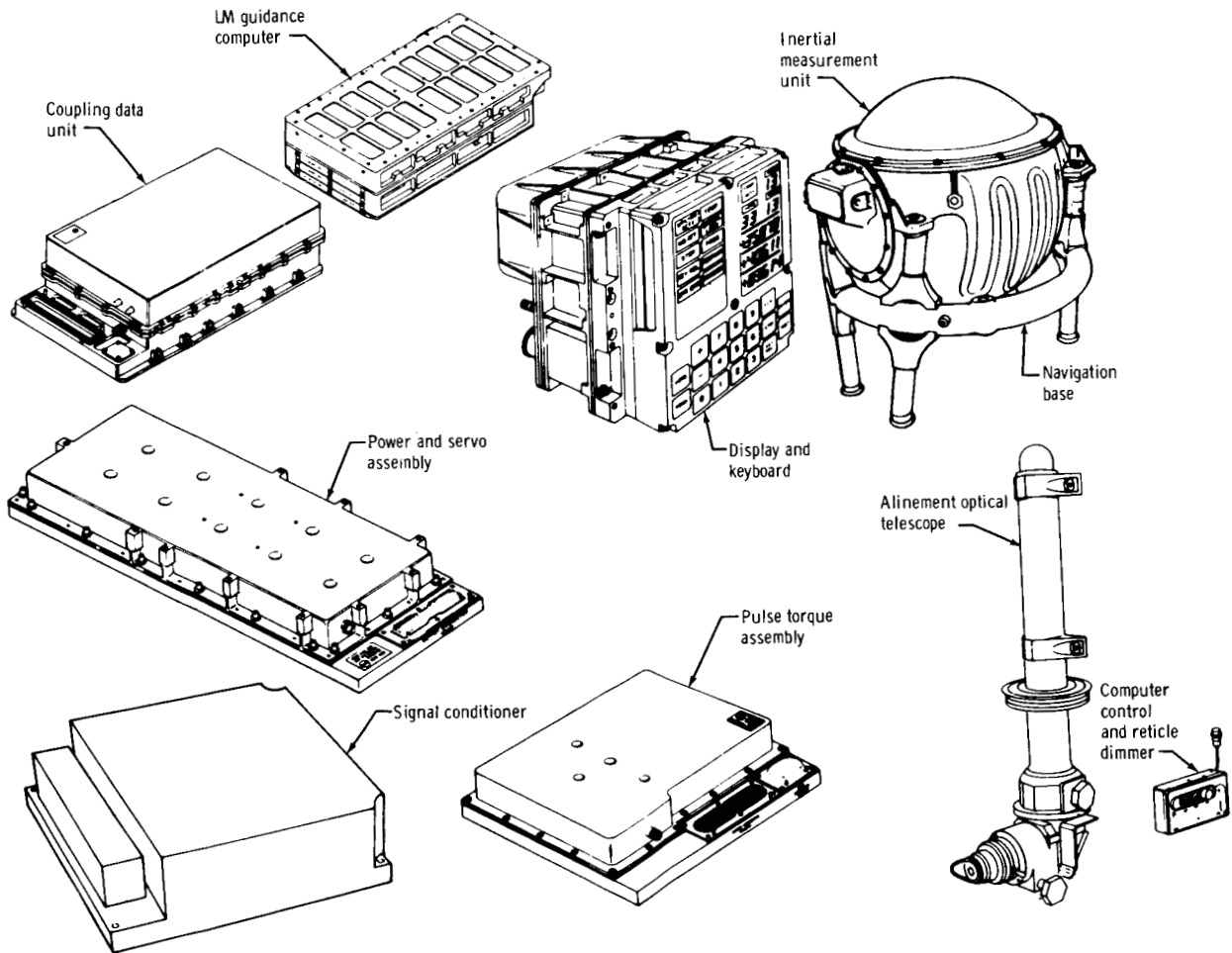

Figure 8. - Lunar module primary guidance, navigation, and control system.

The ACA supply attitude rate commands (proportional to the displacement of the stick) to the computer and to the ATCA, supply an out-of-detent discrete command each time the handle is out of its neutral position, and supply a followup discrete command to the AGS.

Functionally, the TTCA are three-axis integrated translation and thrust controllers that enable astronauts to command vehicle translations by firing RCS thrusters and to throttle the descent engine between 10- and 92.5-percent thrust levels.

The ATCA controls LM attitude and translation. In the PGNCS path, attitude and translational commands are generated and applied directly to jet drivers within the assembly. In the AGS path, the ATCA receives translational commands from the TTCA, rate-damping signals from the RGA, and attitude/rate commands and pulse commands from the ACA. The assembly combines attitude and translational commands in its logic network to select the proper thrusters to be fired for the combination of translation and rotation. The DECA accepts engine-on and engine-off commands from

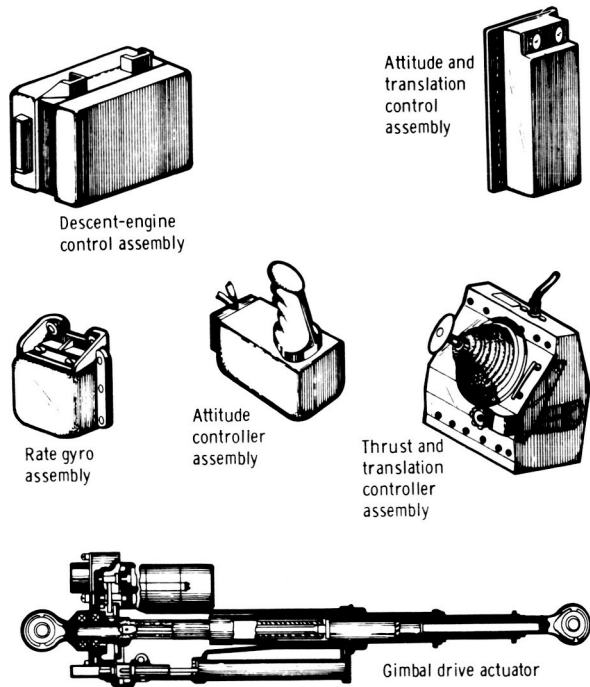

Figure 9. - Lunar module stabilization and control system.

rebalanced, single-degree-of-freedom, rate-integrating gyros and three pendulous reference accelerometers. The data entry and display assembly consists of a control

the SCS control assemblies, throttle commands from the PGNCs and the TTCA, and trim commands from the PGNCs or the ATCA. The assembly applies throttle commands to the descent engine and routes trim commands to the GDA.

The AGS (fig. 10 and ref. 12), which is used as a backup for the PGNCs during an LM mission abort, determines the LM trajectory or trajectories required for rendezvous with the CSM and can guide the LM from any point in the mission, from CSM/LM separation to CSM/LM rendezvous and docking, including ascent from the lunar surface. The AGS can provide data for displays and for explicit guidance computations and can also enable engine ignition and shutdown.

The AGS consists of a nongimbaled inertial reference package (the abort sensor assembly) that is rigidly strapped to the LM rather than mounted on a gimbaled, stabilized platform. The abort sensor assembly contains three floated, pulse-

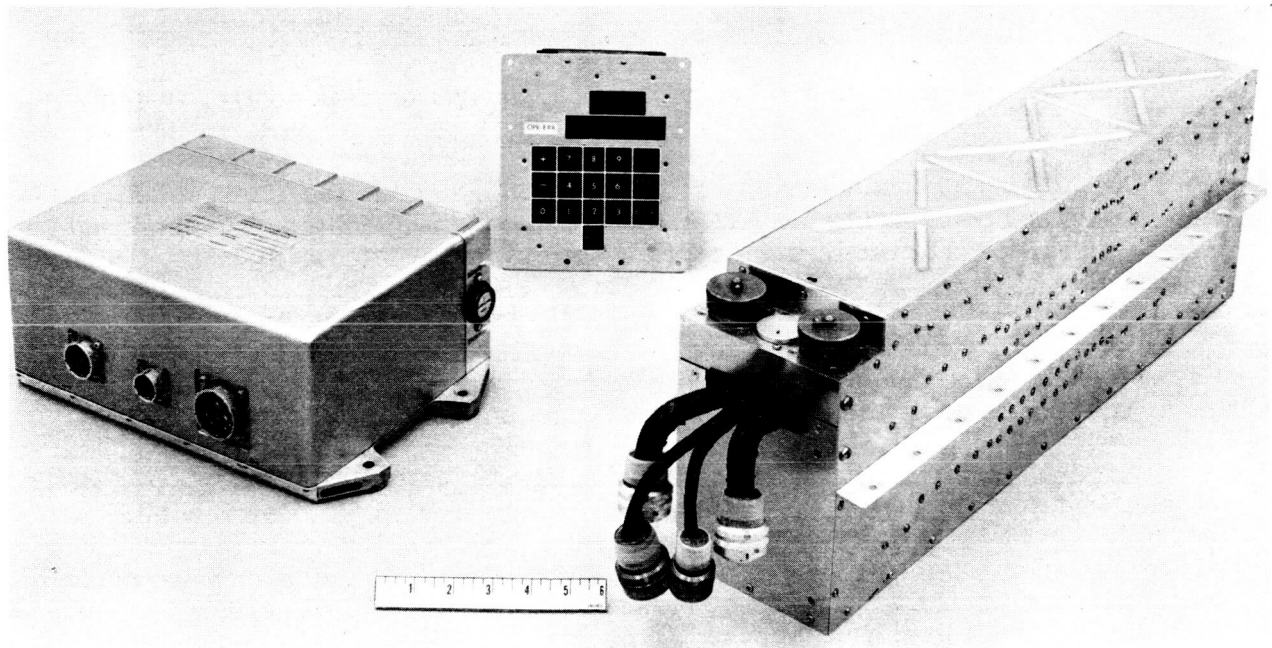

Figure 10. - Lunar module abort guidance system.

panel (to which electroluminescent displays and data entry pushbuttons are mounted) and a logic enclosure that houses logic and input/output circuits. The abort electronics assembly is a high-speed, general-purpose computer with special-purpose input/output electronics components. The computer has a memory capacity of 4096 words, of which half are permanent and half are temporary.

The ORDEAL assembly in the LM is identical to the unit used in the CSM.

CONCLUDING REMARKS AND RECOMMENDATIONS

During the course of the development, qualification, and flight programs, the Apollo guidance and control systems performed in an outstanding manner. There were no guidance and control failures or malfunctions that precluded mission completion or that placed the flight crew or the mission in jeopardy.

In general, the approaches that were used to establish and implement guidance and control system interfaces and checkout procedures during the integration of the systems in the spacecraft appear to have been sound. Consequently, few interface problems appeared during the integration of the systems into the spacecraft. Some of the more significant items that deserve careful consideration on future programs are as follows.

1. A strong effort should be made to establish baseline requirements before the start of hardware design and software development processes. For example, changes affecting hand controllers, humidity, and in-flight maintenance caused major redesign efforts.
2. A failure-analysis technique should be developed to assist in the identification of single-point failures. The Apollo method, in which many engineers must search diagrams for problems, is not altogether successful for complex systems.
3. Criteria and methods to obtain extended-duration hardware reliability should be established. The long checkout times and the extended durations of some missions put a premium on checkout, storage, and long-life operation of equipment.
4. Serious consideration should be given to the use of solid-state devices for switching instead of relays and switches. If relays are used, superscreening tests should be established to ensure high reliability.
5. System integration can be best achieved if a single vendor supplies the hardware for system-level requirements such as the command and service module stabilization and control system. This approach contrasts with the lunar module stabilization and control system procurement, which was at the assembly level with the contractor retaining responsibility for integration. Although system-level procurement is not a panacea for all problems, interface problems are more easily avoided than with assembly-level procurement.
6. Thermal-vacuum testing revealed as many failures as vibration testing revealed. Both environments should be used in assembly acceptance testing.

7. Numerous experiences in the program have demonstrated the necessity for having immediate access to an alternate source of qualified parts to support scheduled program milestones.

8. Because of schedule constraints, the abort guidance system program (as an example) did not include the use of an engineering model for design evaluation before the system was committed to production. Many manufacturing and circuit-design problems could have been corrected early if an engineering evaluation model had been available.

9. The initial integration of the guidance and control systems with the spacecraft caused many problems during vehicle checkout. The participation of the subcontractors (for example, those who built the individual parts of the lunar module stabilization and control system) would have been valuable during the resolution of those problems. A review by the subcontractor of vehicle checkout procedures and onsite support during spacecraft integration would prove beneficial in future programs.

10. Definition of vehicle test methods, particularly combined-systems and integrated-systems testing, should be established early to avoid interface and interference problems.

11. Experience gained during the development of the Apollo digital autopilots may be used to avoid future design problems. Logical decision techniques should be applied with care in design development because conditions may exist in which these techniques can unexpectedly lock out entire system functions. The use of logic in avoiding degraded performance has to be traded off with unintended restrictions.

12. Further research effort should be expended to develop additional analytical techniques for digital control system design. Adaptive design techniques making use of the inherent flexibility available in digital systems should also be established.

13. Design requirements should include the requirement to preserve the capability for monitoring system effectiveness. For example, efficient use of the delta-velocity capability of the Apollo service propulsion system placed only mild constraints on maintaining small vehicle-attitude errors and rates during the start transient; however, a design goal was to produce a system that minimized these start transients for nominal operation so that the transients would be useful indicators of potentially serious off-nominal conditions.

14. Caution must also be exercised in placing too much reliance on simulation results for design verification without a full appreciation of the approximations that have been made in developing the process models and in implementing these models in the simulations. The implementation becomes particularly important when simulating high frequency dynamics in a digital computer.

15. Engineering simulation should be recognized as a potentially large, expensive operation and, as such, should be given appropriate attention during the initial contract definition and negotiations to ensure the establishment of well-defined baseline plans and costs.

16. The role that simulation is expected to have in the program should be defined in enough specific detail to enable establishment of an appropriate simulation plan that is adequate, but not unnecessarily elaborate. If possible, this definition should be included in the request for proposal so that the contractor can provide appropriate plans and costs.

17. Management of the simulation activity should be delegated in some appropriate way so that the activity will receive adequate full-time attention.

18. Consideration should be given to having large simulators that require system hardware constructed at Government facilities. Contractor personnel would be used as required during construction and during initial phases of operation; civil service personnel would be used later in the program.

19. Detailed planning for large simulators should begin early in the program, but actual implementation should be delayed as long as possible to avoid tracking and incorporating interim changes to the system being simulated.

20. Detailed planning should be designed to ensure the inclusion of requirements for special-purpose equipment needed for interface or system simulation, requirements for external scene generators, and provisions for data input and output. Careful planning is important because these requirements can become expensive.

21. At the beginning of the proposed program, the degree of desired formality associated with the simulator operation should be determined so that proper plans can be made. Configuration control, documentation, extra sets of hard-copy data, formal test-readiness reviews, and anomaly reporting can create a greatly increased workload for support personnel.

Lyndon B. Johnson Space Center
National Aeronautics and Space Administration
Houston, Texas, November 8, 1974
914-50-00-00-72

REFERENCES

1. Holloway, Gene F. : Apollo Experience Report – Guidance and Control Systems: Automated Control System for Unmanned Mission AS-201. NASA TN D-7991, 1975.
2. Holloway, Gene F. : Apollo Experience Report – Guidance and Control Systems: Mission Control Programmer for Unmanned Missions AS-202, Apollo 4, and Apollo 6. NASA TN D-7992, 1975.
3. Peters, William H.; and Cox, Kenneth J. : Apollo Experience Report – Guidance and Control Systems: Digital Autopilot Design Development. NASA TN D-7289, 1973.
4. Gilbert, David W. : Apollo Experience Report – Guidance and Control Systems: Engineering Simulation Program. NASA TN D-7287, 1973.
5. Holley, M. D.; Swingle, W. L.; et al. : Apollo Experience Report – Guidance and Control Systems: Primary Guidance, Navigation, and Control System Development. NASA TN D-8227, 1976.
6. McMahon, William A. : Apollo Experience Report – Guidance and Control Systems: CSM Service Propulsion System Gimbal Actuators. NASA TN D-7969, 1975.
7. Littleton, Orval P. : Apollo Experience Report – Guidance and Control Systems: Command and Service Module Stabilization and Control System. NASA TN D-7785, 1974.
8. Reina, Ben, Jr.; and Patterson, Herbert G. : Apollo Experience Report – Guidance and Control Systems: Command and Service Module Entry Monitor Subsystem. NASA TN D-7859, 1975.
9. Parker, Roy B.; and Sollock, Paul E. : Apollo Experience Report – Guidance and Control Systems: Orbital Rate Drive Electronics for the Apollo Command Module and Lunar Module. NASA TN D-7784, 1974.
10. Vernon, Jesse A. : Apollo Experience Report – Guidance and Control Systems: Lunar Module Mission Programmer. NASA TN D-7949, 1975.
11. Shelton, D. H. : Apollo Experience Report – Guidance and Control Systems: Lunar Module Stabilization and Control System. NASA TN D-8086, 1975.
12. Kurten, Pat M. : Apollo Experience Report – Guidance and Control Systems: Lunar Module Abort Guidance System. NASA TN D-7990, 1975.