

NATIONAL AERONAUTICS AND SPACE ADMINISTRATION

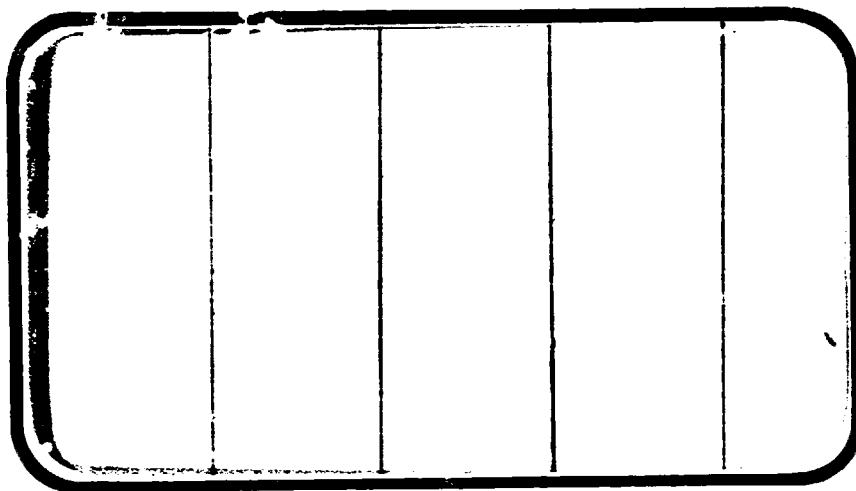

(NASA-CR-147608) AN INVESTIGATION TO
DETERMINE THE PRESSURE DISTRIBUTION ON THE
0.0137 SCALE SOLID ROCKET BOOSTER FOREBODY
(MSPC MODEL 467) AT ANGLES OF ATTACK AT OR
NEAR 90 DEG AND HIGH FREYNOLDS NUMBERS IN THE G3/18

N76-27343
HC 6.00

Unclas
45766

SPACE SHUTTLE

AEROTHERMODYNAMIC DATA REPORT

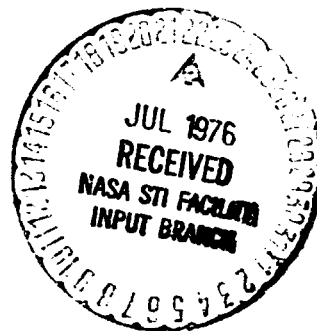

JOHNSON SPACE CENTER

HOUSTON, TEXAS

DATA Management services



May, 1976

DMS-DR-2207
NASA-CR-147,608
AN INVESTIGATION TO DETERMINE
THE PRESSURE DISTRIBUTION ON THE 0.0137 SCALE
SOLID ROCKET BOOSTER FOREBODY
(MSFC MODEL 467) AT ANGLES OF ATTACK AT
OR NEAR 90° AND HIGH REYNOLDS NUMBERS IN THE
MSFC HIGH REYNOLDS NUMBER WIND TUNNEL (SA29F)

by

Paul E. Ramsey, NASA/MSFC

Prepared under NASA Contract Number NAS9-13247

by

Data Management Services
Chrysler Corporation Space Division
New Orleans, La. 70189

for

Engineering Analysis Division
Johnson Space Center
National Aeronautics and Space Administration
Houston, Texas

WIND TUNNEL TEST SPECIFICS:

Test Number: MSFC HRWT 033
NASA Series No.: SA29F
Model Number: 467
Test Dates: August 8 - September 18, 1974
June 25 - July 14, 1975

FACILITY COORDINATOR:

Mr. Dale Andrews
Marshall Space Flight Center
Mail Stop ED32
Huntsville, Alabama 35801

Phone: (205) 453-3174

PROJECT ENGINEER:

Mr. Paul E. Ramsey
Marshall Space Flight Center
Mail Stop ED32
Huntsville, Alabama 35801

Phone: (205) 453-3152

DATA MANAGEMENT SERVICES:

Prepared by: Liaison--V. W. Sparks
Operations--V. W. Sparks

Reviewed by: G. G. McDonald

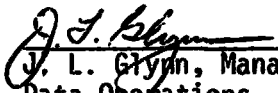
Approved: 
J. L. Glynn, Manager
Data Operations

Concurrence: 
N. D. Kemp, Manager
Data Management Services

Chrysler Corporation Space Division assumes no responsibility for the data presented other than display characteristics.

AN INVESTIGATION TO DETERMINE THE PRESSURE
DISTRIBUTION ON THE 0.0137 SCALE SOLID ROCKET
BOOSTER FOREBODY (MSFC MODEL 467) AT ANGLES
OF ATTACK AT OR NEAR 90° AND HIGH REYNOLDS NUMBERS
IN THE MSFC HIGH REYNOLDS NUMBER WIND TUNNEL (SA29F)

by

Paul E. Ramsey, NASA/MSFC

ABSTRACT

An aerodynamic investigation was conducted in the MSFC High Reynolds Number Wind Tunnel to determine the pressure distribution over the fore-section of the current 146 inch diameter Shuttle SRB. The test model consisted of a 0.0137 scale version of the SRB nose cone and a forward portion of the cylindrical body which was approximately 2.7 calibers in length. The external configuration was defined by MSFC drawing number 10A00313 Revision A.

Data were obtained for Mach numbers of 0.4, 0.5, 0.6, 0.8, and 2.0; Reynolds numbers of from $2.3(10)^6$ to $20.1(10)^6$ based on body diameter; angle of attack of 72°, 90°, and 108°, circumferential body locations from 0° to 180°; and longitudinal station ratioed to body diameter (X/D) of from 0.340 to 2.160. Yaw was zero and no protuberances were fitted.

The pressure distributions are plotted as a function of longitudinal station ratioed to body diameter and circumferential location for

ABSTRACT (Concluded)

each angle of attack and Mach number. A Reynolds number variation study was made for Mach numbers of 0.4 and 0.6 at an angle of attack of 270° and roll angle of 180° .

TABLE OF CONTENTS

	Page
ABSTRACT	iii
INDEX OF MODEL FIGURES	2
INDEX OF DATA FIGURES	3
NOMENCLATURE	4
INTRODUCTION	6
TEST HARDWARE	8
INSTRUMENTATION	9
TEST FACILITY DESCRIPTION	10
DATA REDUCTION	11
REFERENCES	12
TABLES	
I. TEST CONDITIONS	13
II. DATA SET/RUN NUMBER COLLATION SUMMARY	15
III. MODEL DIMENSIONAL DATA	19
IV. ORIFICE NUMBERING SYSTEM	20
FIGURES	
MODEL	21
DATA	25
APPENDIX - TABULATED SOURCE DATA	

INDEX OF MODEL FIGURES

Figure	Title	Page
1	Body and Missile Axis Systems	21
2.	Details and Major Dimensions of SRB Forward Section and Sting	22
3.	Pressure Orifice Location and Identification System	23
4.	SRB Foresection Model Installed in the MSFC HRWT Transonic Test Section	24

INDEX OF DATA FIGURES

	SCHEDULE OF COEFFICIENTS PLOTTED	CONDITIONS VARYING	PAGES
PRESSURE COEFFICIENT ALONG THE BODY AT VARIOUS POSITIONS AROUND THE BODY	(A)	THETA MACH ALPHA	1-46
PRESSURE COEFFICIENT AROUND THE BODY AT VARIOUS STATIONS AROUND THE BODY	(B)	X/D MACH ALPHA	47-78
EFFECT OF REYNOLDS NUMBER ON PRESSURE COEFFICIENTS AT VARIOUS BODY STATIONS	(B)	RN X/D ALPHA MACH	79-90

PLOTTED COEFFICIENTS SCHEDULE:

- (A) CP versus X/D
- (B) CP versus THETA

NOMENCLATURE

General

<u>SYMBOL</u>	<u>PLOT SYMBOL</u>	<u>DEFINITION</u>	<u>UNITS</u>
C_p	CP	pressure coefficient; $(p_1 - p_\infty)/q_\infty$	
D		reference diameter (body diameter)	
l_B	LBODY	length of the ET	in.
M		Mach number	
P_1		local pressure	psi
P_t		total pressure	psi
P_∞		freestream pressure	psi
q_∞	Q(PST)	freestream dynamic pressure unit	psi
R_N	RN	Reynolds number based on model diameter	
R_N/L	RN/L	Reynolds number per unit length	
SRB		Solid Rocket Booster	
S_{Ref}	SREF	base area or reference area, ft ²	
T_t		freestream total temperature (°F)	deg.
X		distance from nose of SRB along X axis	in.
X_T, Y_T, Z_T		SRB stations	in.
X/D	X/D	longitudinal location of pressure measurement, expressed as a fraction of the SRB length, measured from the SRB nose	
P_0		plenum chamber pressure	psia

NOMENCLATURE (Concluded)

<u>SYMBOL</u>	<u>PLOT SYMBOL</u>	<u>DEFINITION</u>	<u>UNITS</u>
<u>GREEK SYMBOLS</u>			
α	ALPHA	angle of attack	deg.
ϕ	PHI	angle of roll	deg.
θ	THETA	circumferential location	deg.
<u>SUBSCRIPTS</u>			
ref		reference conditions	
∞		freestream conditions	
l		local	
t		total conditions	

INTRODUCTION

During the descent of the SRB, an atmospheric pressure switch or baroswitch will be used to initiate the Shuttle SRB parachute deployment system. This device will be located in a forward compartment which will be vented to the exterior environment. The internal pressure of this compartment is a function of the external conditions such as SRB velocity, attitude, and altitude which are predicted from aerodynamic force inputs into a dynamics analysis program. Based on the internal pressure, which corresponds to the desired parachute deployment altitude for a given entry trajectory, the baroswitch can be preset for recovery system initiation at the proper time. Initiation must occur within narrow altitude limits to assure the occurrence of the dynamic pressure needed for proper functioning of the parachute system. To obtain an accurate prediction of the forward compartment pressure needed to set the baroswitch, the external pressure distribution must be known for the full scale flight conditions.

Since the SRB will enter at an angle of attack near 90° where the flow around the body can be very sensitive to Reynolds number, a test Reynolds number as near to full scale as possible is necessary if adequate data are to be obtained.

Based on these observations, a test was conducted in the MSFC High Reynolds Number Wind Tunnel to determine the SRB forebody pressure distribution at 72° to 108° angle of attack. Pressures were measured over the nose cone and approximately one caliber of the cylindrical body. The

INTRODUCTION (Concluded)

Mach range consisted of 0.4, 0.5, 0.6, 0.8, and 2.0 at Reynolds numbers based on the SRB diameter. No protuberances were fitted for this investigation.

TEST HARDWARE

The model configuration consisted of a spherically blunted cone/cylinder which simulated the forward portion of the current 146-inch-diameter SRB. The model was mounted at the aft end with a 90° "dog leg" sting which was then supported in an available tunnel sting. Major dimensions of the model and sting are presented in Figure 2.

Because only 18 pressure tubes of 0.125-inch O.D. could be accommodated in the model, 4 interchangeable nose sections were provided, each containing 18 pressure orifices. The pressure tubing passed out of the nose through an O-ring sealed quick-disconnect system which allowed easy interchangeability of the nose sections. From this disconnect the tubing passed through cavities in the sting to the tunnel exterior.

No protuberances were included on the test models. The model diameter was 2 inches, which resulted in a scale of 0.0137. The MSFC model number is 467 and was fabricated using drawings 80M42699, 80M42700, 80M42714 - 80M42717, and 80M51377.

INSTRUMENTATION

The orifice location and arrangement are shown in Figure 3. The pressure lines were tubed to 18 Statham 1000 psia pressure transducers, which were monitored real time during each run. Combining data from each nose resulted in a total set of data for 72 orifice locations distributed over the test SRB configuration. In effect, four blows or runs were required to obtain a complete set of data for each test condition; i.e., Mach number, α , P_0 , and Reynolds number.

Two check orifices at thetas of $202\frac{1}{2}^\circ$ and $337\frac{1}{2}^\circ$ at longitudinal station 7 were included on nose 4 to give an indication of model misalignment or flow asymmetries. Because of the limited interior volume available near the front of the model, pressure taps were located on both sides of the nose for longitudinal station 1 on nose 4.

TEST FACILITY DESCRIPTION

The MSFC High Reynolds Number Wind Tunnel (HRWT) is a Ludwig tube tunnel capable of producing a Reynolds number range of 7×10^6 to 200×10^6 per foot over a Mach number range of 0.25 to 3.50. The test section is 32 inches in diameter by 64 inches in length.

The supply tube has a 52-inch inside diameter and is 386 feet long. It is terminated on one end with a hemispherical head and on the other end with a stilling chamber. The stilling chamber is 20 feet long and has a maximum diameter of 78 inches. The entrance cone has an 8-degree included angle.

The facility uses six interchangeable, axisymmetric, contoured nozzles. The diameters at the entrance and exit of each nozzle are 52 and 32 inches, respectively. The "sonic" nozzle is used to produce all subsonic and transonic speeds. The other five nozzles are designed for discrete Mach numbers 1.4, 1.7, 2.0, 2.75, and 3.5. Further details and performance characteristics of the HRWT are presented in Reference 1.

DATA REDUCTION

The data were reduced to pressure coefficients as follows.

$$C_p = \frac{P_1 - P_\infty}{q_\infty}$$

and tabulated in the format shown in Table IV. The data were also formatted for inclusion in the CCSD data management system. Tunnel test condition parameters such as run number, Mach number, α , q_∞ , T , RN , and P_0 are included in the tabulated data of the Appendix.

REFERENCES

1. Gwin, H. S., "The George C. Marshall Space Flight Center High Reynolds Number Wind Tunnel Technical Handbook," NASA TM X-64831, December 1973.

TABLE I.

TEST: MSFC HRWT 033			DATE: 10/17/75	
TEST CONDITIONS				
MACH NUMBER	REYNOLDS NUMBER (per unit length)	DYNAMIC PRESSURE (pounds/sq. inch)	STAGNATION TEMPERATURE (degrees Fahrenheit)	STAGNATION PRESSURE (pounds/sq. inch)
0.4	2.3 x 10 ⁶	7.3	37	67.8
	4.0	13.4	51	128.1
	6.0	19.9	46	191.4
	7.5	25.4	49	238.8
	8.4	28.2	51	263.1
	8.9	30.2	49	286.8
	10.2	32.7	38	315.9
	13.3	44.6	48	424.2
	18.1	61.2	48	589.8
Y	18.8	61.3	44	590.1
0.5	18.1	75.2	49	506.7
0.6	2.8	13.0	48	64.3
T	4.0	18.7	41	92.2
	6.0	27.3	46	136.6
	7.5	34.4	51	175.4
Y	8.9	40.3	47	204.2
BALANCE UTILIZED: <u>NONE - STATHAM PRESSURE TRANSDUCERS</u>				
	CAPACITY:	ACCURACY:	COEFFICIENT TOLERANCE:	
NF	<u>1000 PSI</u>	<u>± 5 PSI</u>	<u>± .06 @ q = 83 PSI</u>	
SF	_____	_____	_____	
AF	_____	_____	_____	
PM	_____	_____	_____	
RM	_____	_____	_____	
YM	_____	_____	_____	
COMMENTS:				

TABLE I. (Concluded)

TEST: MSFC HRWT 033		DATE:		
TEST CONDITIONS				
MACH NUMBER	REYNOLDS NUMBER (per unit length)	DYNAMIC PRESSURE (pounds/sq. inch)	STAGNATION TEMPERATURE (degrees Fahrenheit)	STAGNATION PRESSURE (pounds/sq. inch)
0.6	9.7 x 10 ⁶	44.8	51	228.9
	12.8	58.9	47	298.8
	13.3	60.1	41	303.6
	16.1	74.6	49	378.9
	18.1	82.6	46	412.4
↓	20.1	90.4	36	451.4
0.8	18.1	98.0	42	346.1
2.0	9.0 ↓	71.7	61	200.3

BALANCE UTILIZED: _____

	CAPACITY:	ACCURACY:	COEFFICIENT TOLERANCE:
NF	_____	_____	_____
SF	_____	_____	_____
AF	_____	_____	_____
PM	_____	_____	_____
RM	_____	_____	_____
YM	_____	_____	_____

COMMENTS:

TABLE II.

TEST: MSFC HRWT 035		DATA SET/RUN NUMBER COLLATION SUMMARY												DATE: 10/17/75																												
DATA SET IDENTIFIER	CONFIGURATION	SCHED. PARAMETERS/VALUES			NO. OF RUNS	MACH NUMBERS (OR ALTERNATE INDEPENDENT VARIABLE)								TEST RUN NUMBERS																												
		α	β	γ		0.4	0.5	0.6	0.8	2.0																																
R1E101	SRB NOSE	92	0	0	18	1					9	14																														
		90				2					11	16																														
R1E102		108				3					13	18																														
		72								14																																
		80								5	10	15																														
		90								6																																
		100								7	12	17																														
R1E103		108								8																																
		72																																								
		80																																								
		90																																								
		100																																								
R1E104		108																																								
		72																																								

α OR β
SCHEMULES

TABLE II. (Continued)

TEST: MSFC HWWT 033		DATA SET/RUN NUMBER COLLATION SUMMARY								DATE: 10/17/95																										
DATA SET IDENTIFIER	CONFIGURATION	PARAMETER				REYNOLDS NUMBER				(OR ALTERNATE INDEPENDENT VARIABLE)				TEST RUN NUMBERS																						
		α	β	M	ϕ	2.3	2.8	4.0	6.0	7.5	8.9	9.7	10.2	12.8	13.3	16.1	18.8	20.1																		
R/E 105	SRB NOSE	270	0	180	0.4			44/6	45/6	43/6	46/6			47/6																						
R/E 105	SRB NOSE	90	0	180	0.4							39/6																								
R/E 106	SRB NOSE	270	0	180	0.6			41/2	48/6	49/6	52/6	50/6	53/6			40/1	51/1	56/6																		

COEFFICIENTS

α OR β SCHEDULES

IDVAR (1) IDVAR (2) NDV

ALPHA

75 76 67 61 55 49 43 37 31 25 19 13 7

TABLE II (Continued)

DATAMAN RUN NUMBER CORRELATION WITH TUNNEL RUN NUMBER

New Run Number	Tunnel Number	α	M
1	24/0, 19/0, 13/0, 18/0	72	0.4
2	1/0, 6/1, 12/1, 7/0	90	↓
3	25/0, 30/1, 36/0, 31/1	108	
4	57/0, 83/0	72	0.5
5	59/1, 79/0	80	↓
6	63/1, 77/2	90	
7	65/1, 73/0	100	
8	69/0, 71/3	108	
9	23/2, 20/0, 14/0, 17/0	72	0.6
10	60/1, 80/0	80	↓
11	2/0, 5/0, 11/1, 8/0	90	
12	66/1, 74/0	100	
13	26/0, 29/1, 35/0, 32/0	108	↓
14	22/2, 21/0, 15/0, 16/0	72	0.8
15	61/3, 81/0	80	↓
16	3/0, 4/0, 10/3, 9/0	90	
17	67/2, 75/0	100	
18	27/0, 28/0, 34/0, 33/0	108	
19	58/0, 84/0	72	2.0
20	62/0, 82/0	80	2.0

TABLE II. (Concluded)

New Run Number	Tunnel Number	α	M
21	64/2, 78/0	90	2.0
22	68/0, 76/1	100	2.0
23	70/0, 72/0	108	2.0

TABLE III.
MODEL DIMENSIONAL DATA

MODEL COMPONENT: BODY - SRB FORWARD SECTION

GENERAL DESCRIPTION: SPHERICALLY BLUNTED 18° HALF ANGLE NOSE CONE AND FORWARD PORTION OF CYLINDRICAL SECTION APPROXIMATELY 2.7 CALIBERS IN LENGTH.

SCALE = 0.0137

DRAWING NUMBER: MSFC DWG. 10A00313 REV. A

DIMENSIONS:	THEORETICAL		ACTUAL MEASURED
	FULL-SCALE	MODEL SCALE	MODEL SCALE
Length	<u>583.9 in.</u>	<u>8 in.</u>	_____
Max. Width	<u>146 in.</u>	<u>2 in.</u>	_____
Max. Depth	<u>146 in.</u>	<u>2 in.</u>	_____
Fineness Ratio	_____	_____	_____
Area			
Max. Cross-Sectional	<u>16,741.5 in.²</u>	<u>3.142 in.²</u>	_____
Planform	_____	_____	_____
Wetted	_____	_____	_____
Base	<u>16,497.6 in.²</u>	<u>3.096 in.²</u>	_____

Table IV. PRESSURE ORIFICE LONGITUDINAL/CIRCUMFERENTIAL LOCATIONS

NOSE NO. LONGITUDINAL STA. NO. X/D LONGITUDINAL LOCATION X (in.) CIRCUMFERENTIAL STA. NO. CIRCUMFERENTIAL LOCATION θ (deg.)	4								3			1			2				
	1		2		3		4		3	4	5	6	7	8	5	6	7	8	
0	A	1	8	17	26	35	44	53	62										
22 1/2	B	-----	9	18	27	36	45	54	63										
45	C	2	10	19	28	37	46	55	64										
67 1/2	D	3	11	20	29	38	47	56	65										
90	E	4	12	21	30	39	48	57	66										
112 1/2	F	5	13	22	31	40	49	58	67										
135	G	6	14	23	32	41	50	59	68										
157 1/2	H	---	15	24	33	42	51	60	69										
180	I	7	16	25	34	43	52	61	70										
202 1/2	B'	-----	-----	-----	-----	-----	-----	71*	-----										
337 1/2	H'	-----	-----	-----	-----	-----	-----	72*	-----										

*Note that 71 and 72 are check orifices located on nose 4 and at longitudinal Station 7 position.

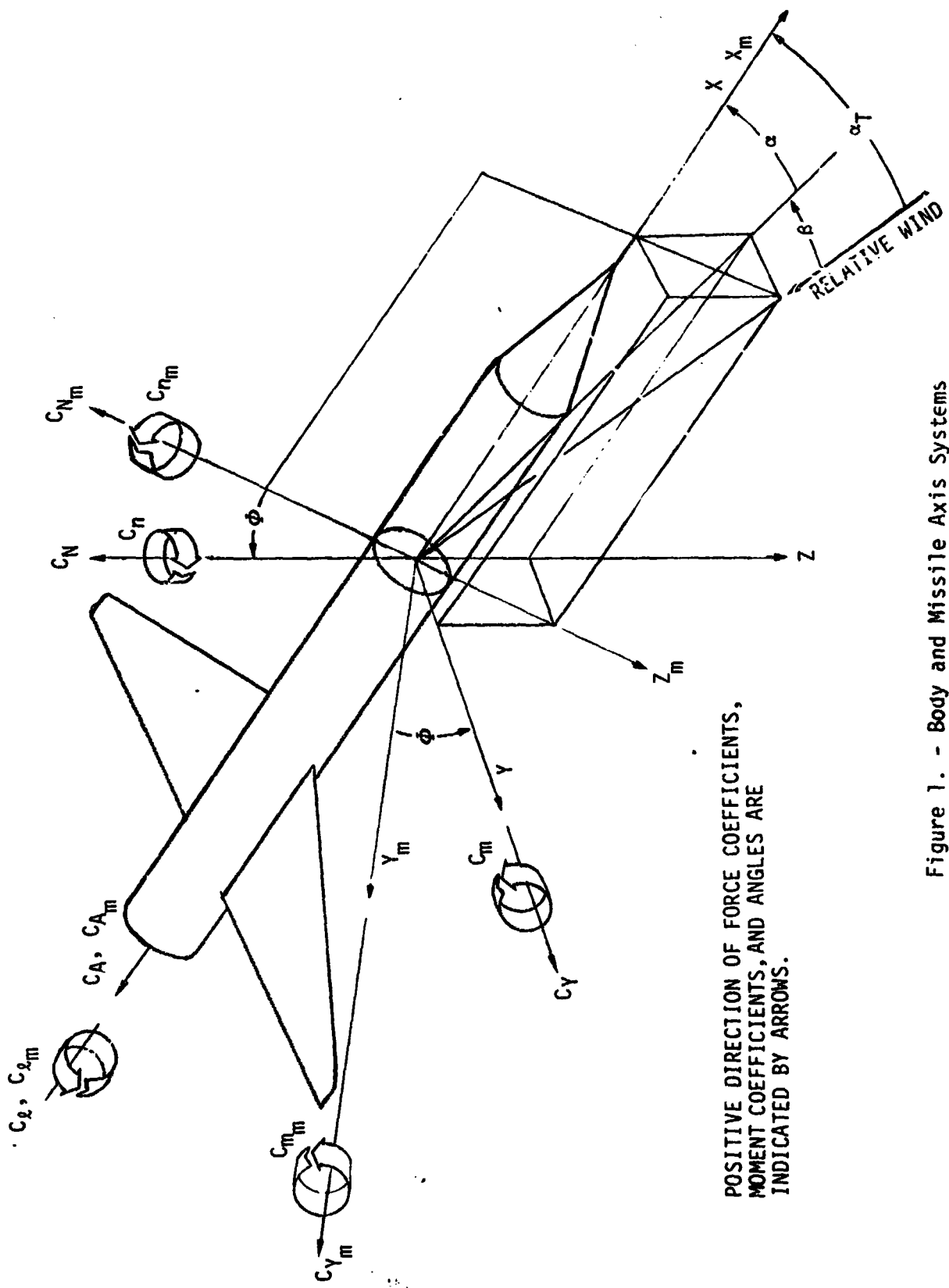

POSITIVE DIRECTION OF FORCE COEFFICIENTS,
MOMENT COEFFICIENTS, AND ANGLES ARE
INDICATED BY ARROWS.

Figure 1. - Body and Missile Axis Systems

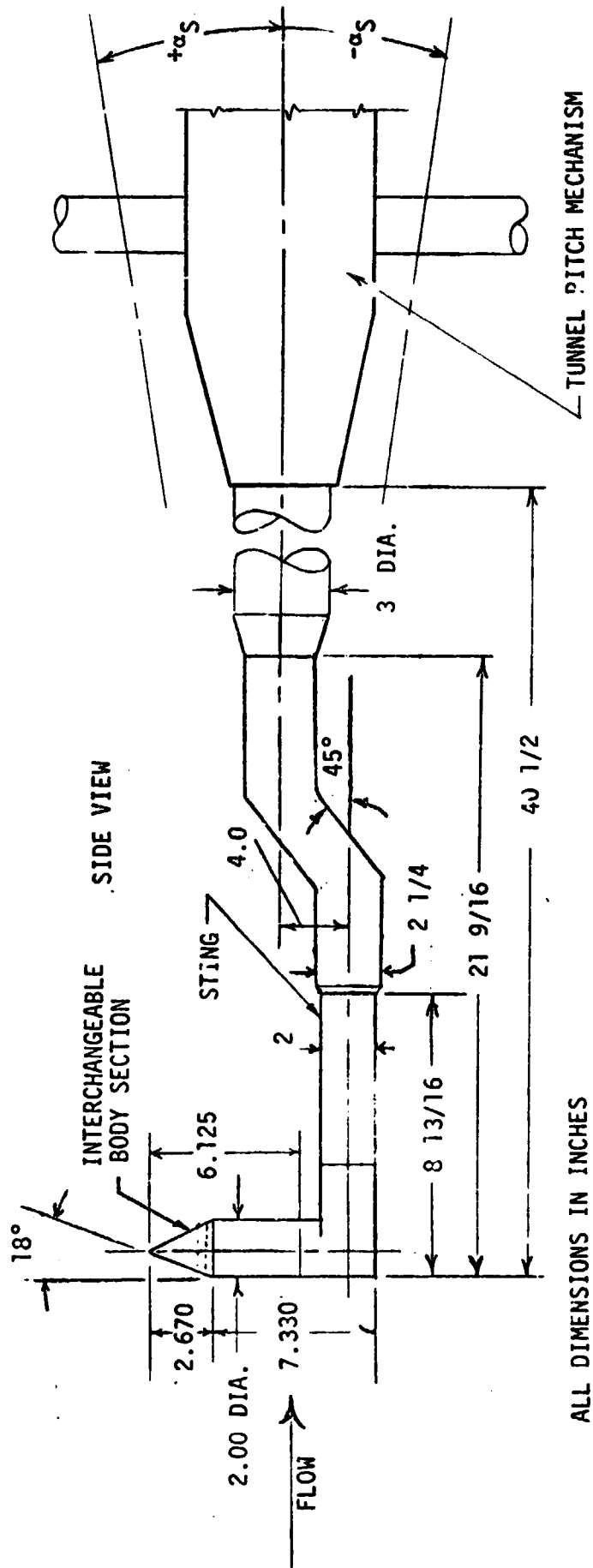

Figure 2. Details and Major Dimensions of SRB Forward Section and Sting

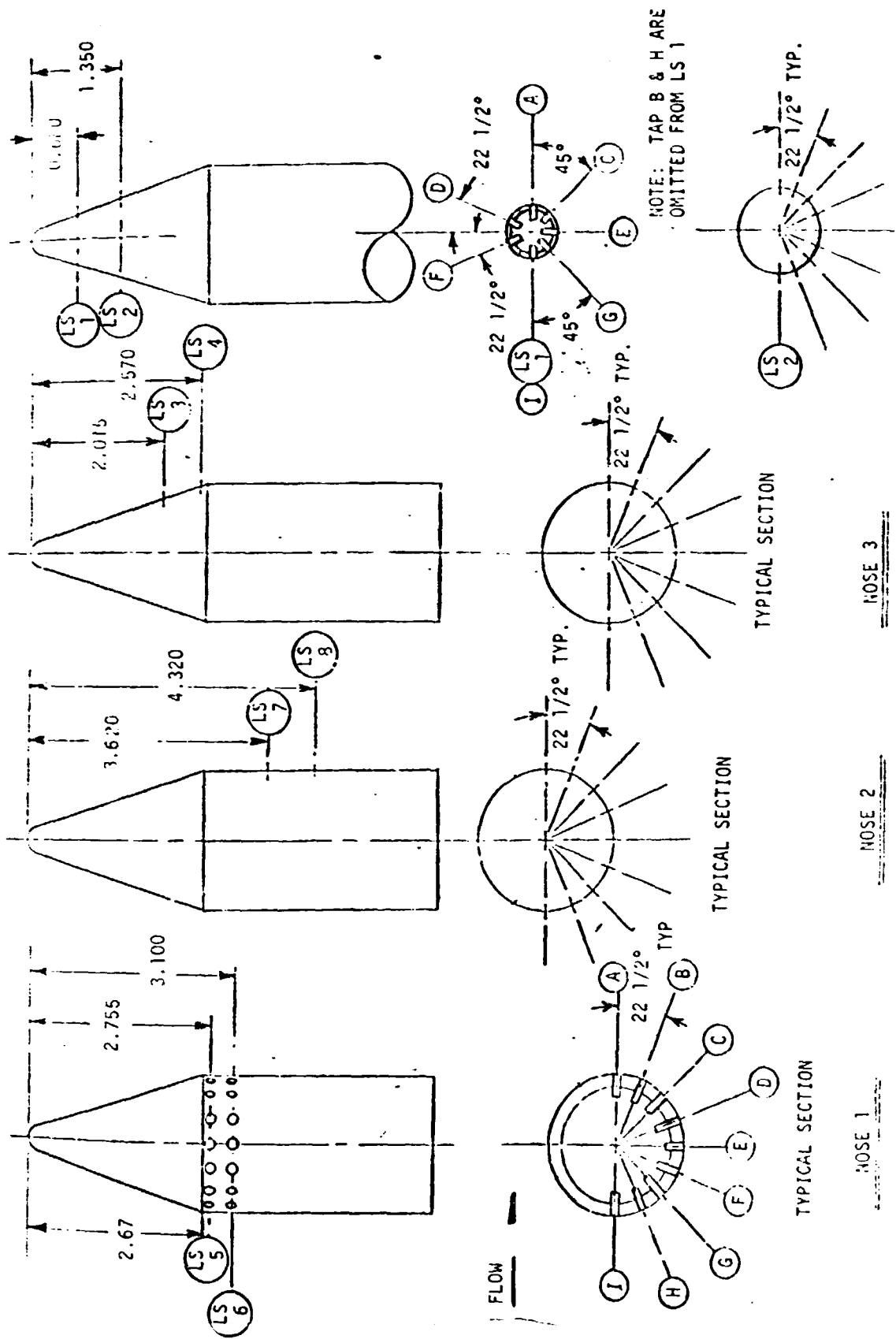

Figure 3. Pressure Orifice Location and Identification System

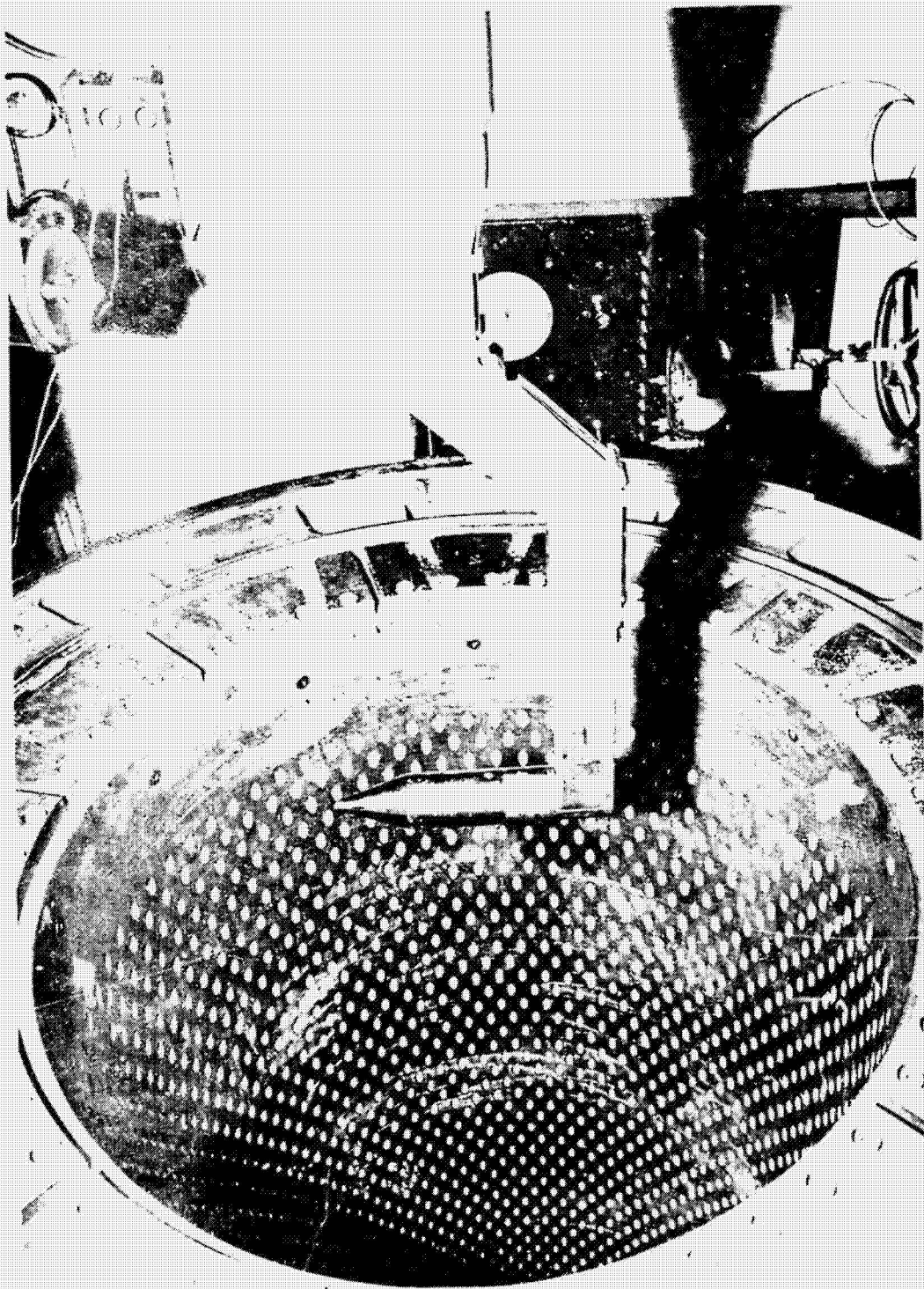
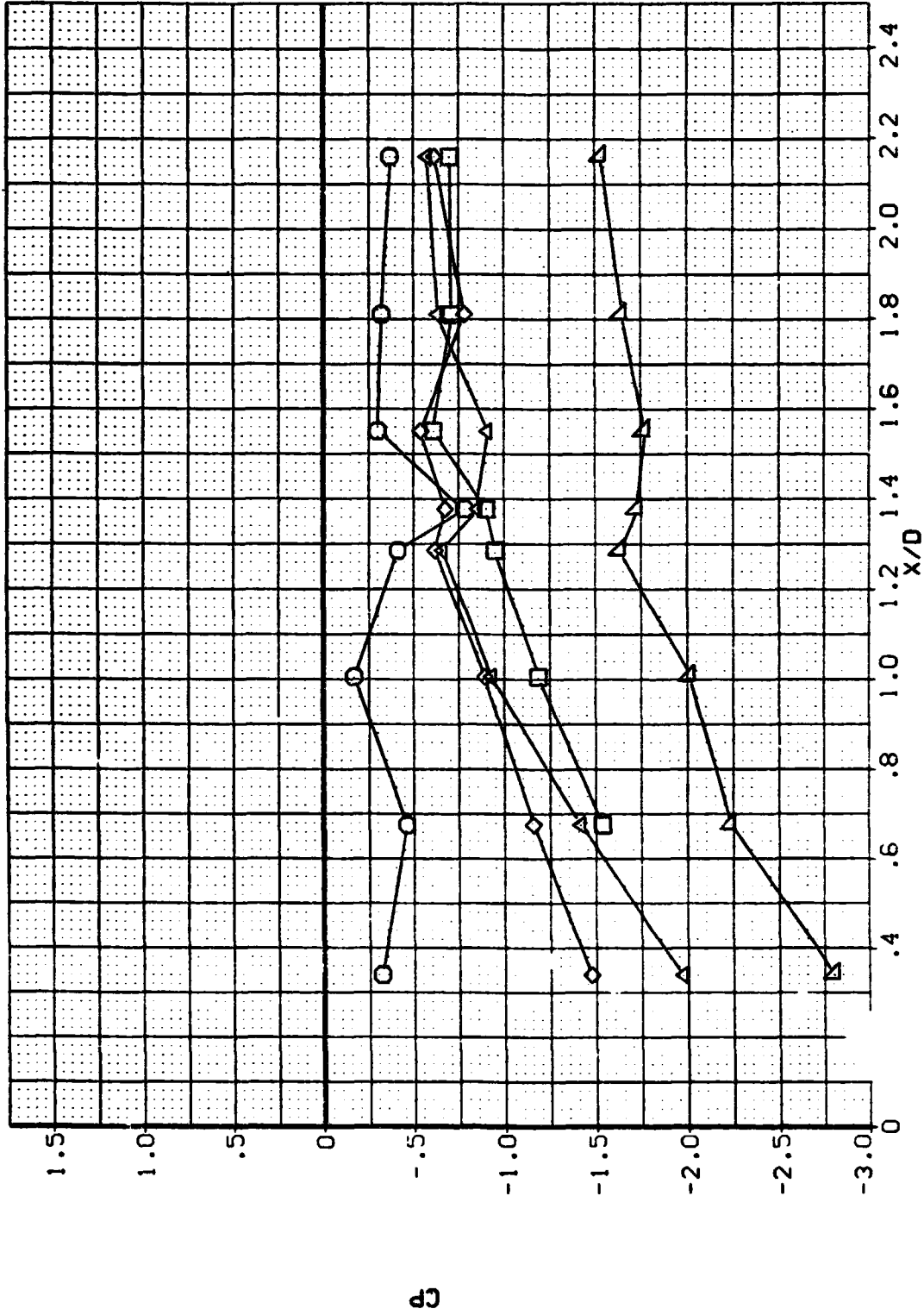

Figure 4. SRB Foresection Model Installed in the
MSFC HRWT Transonic Test Section

DATA FIGURES

MSFC HRWT 033 (SA29F) SRB FORWARD NOSE SECTION (A1E101)

SYMBOL	THETA	ALPHA	MACH	BETA	PARAMETRIC VALUES
	.000	72.100	.410	RN	.000 PHI
○	22.500				18.100
□	45.000				
◇	67.500				
△	90.000				



PRESSURE COEFFICIENT ALONG THE BODY AT VARIOUS POSITIONS AROUND THE BODY

MSFC HRWT 033 (SA29F) SRB FORWARD NOSE SECTION (A1E101)

SYMBOL	THETA	IA	MACH	BETA	PARAMETRIC VALUES
○	112.500	74.100	.410	RN	.000 PHI
□	135.000				18.100
◇	157.500				
△	180.000				

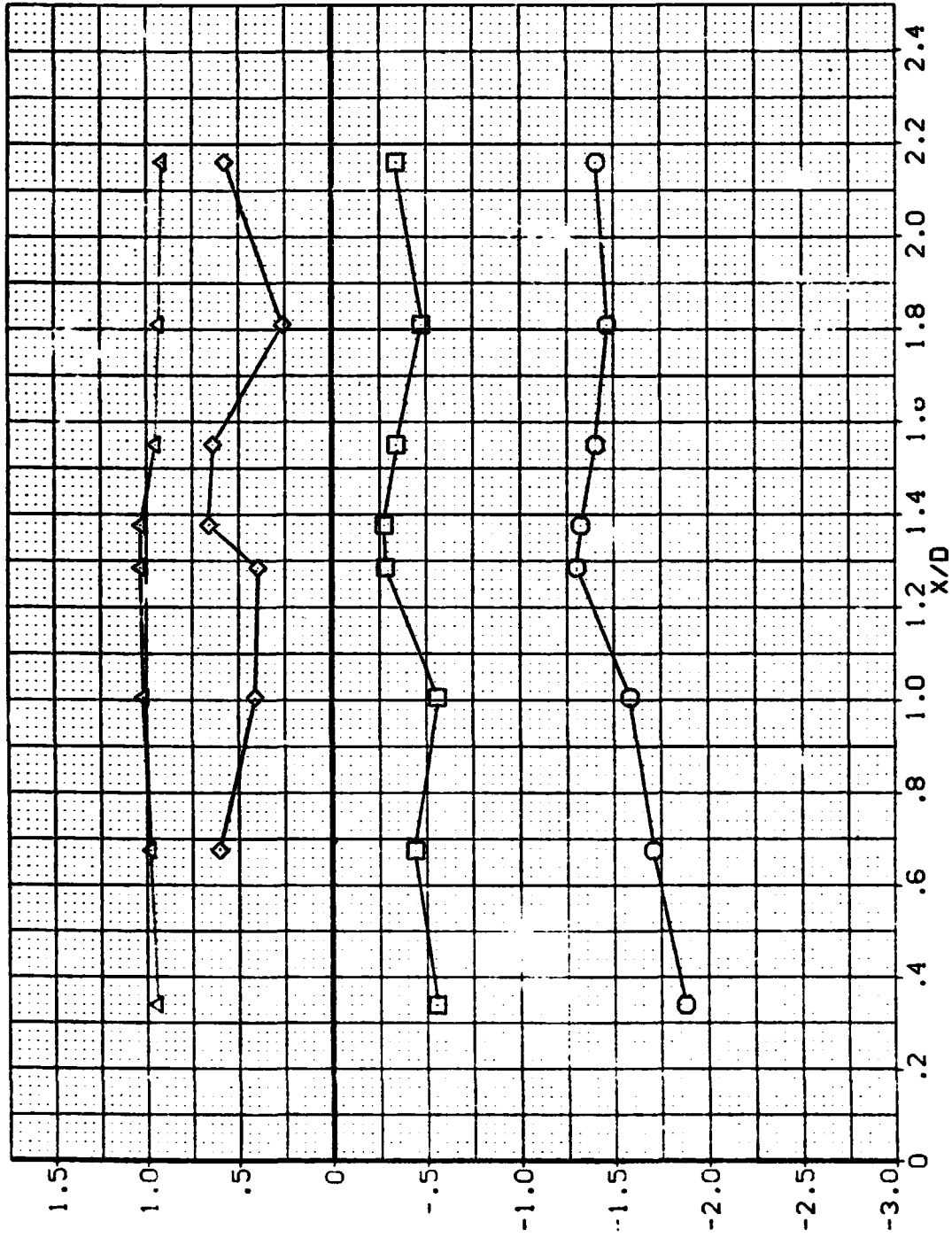

PRESSURE COEFFICIENT ALONG THE BODY AT VARIOUS POSITIONS AROUND THE BODY

MSFC HRWT 033 (SA29F) SRB FORWARD NOSE SECTION (A1E102)

PARAMETRIC VALUES
 .000 PHI .000
 18.100

BETA
 RN

ALPHA MACH
 72.000 .500

THETA
 .000
 22.500
 45.000
 67.500
 90.000

SYMBOL
 ○ □ ◇ △

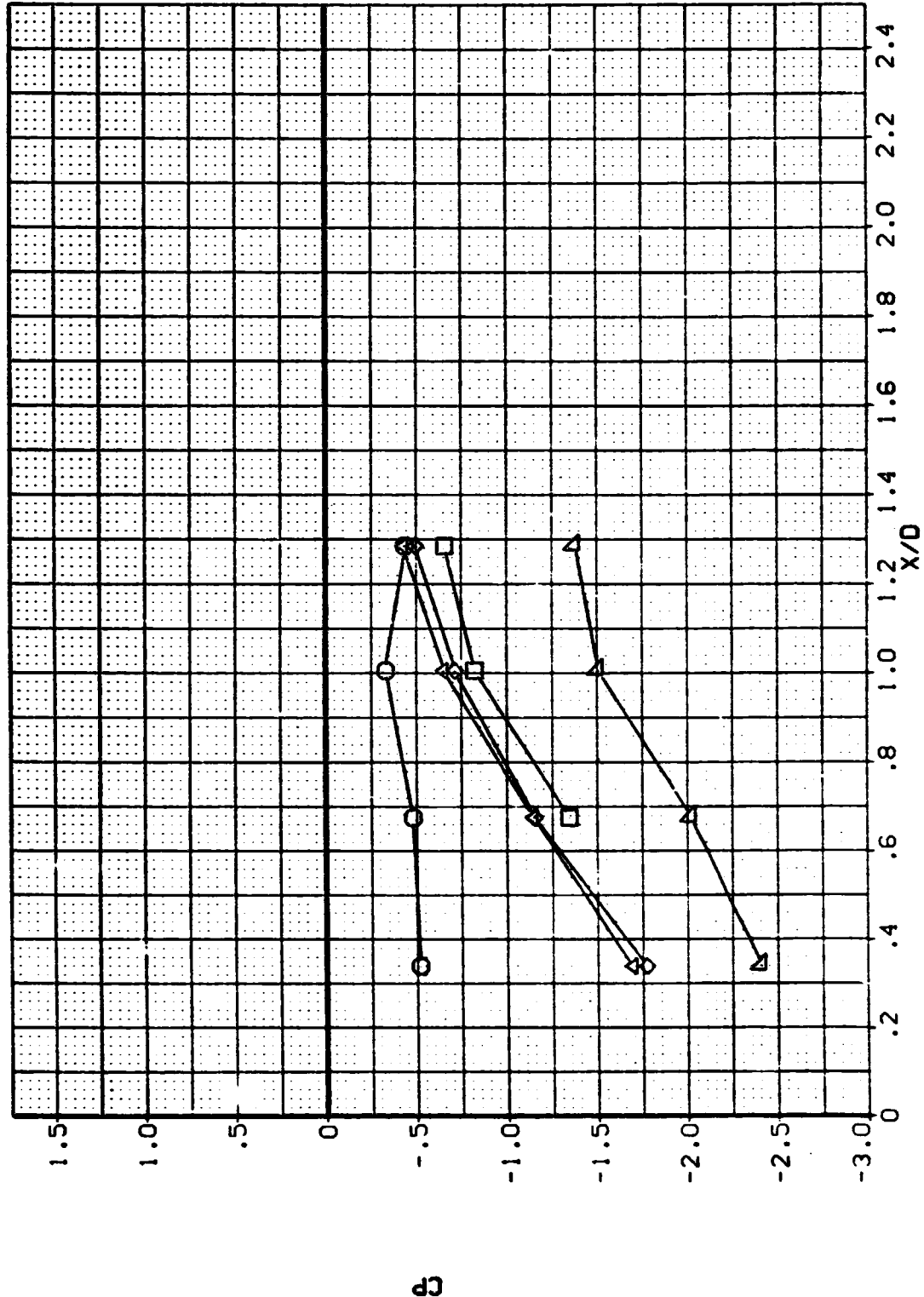

PRESSURE COEFFICIENT ALONG THE BODY AT VARIOUS POSITIONS AROUND THE BODY

MSFC HRWT 033 (SA29F) SRB FORWARD NOSE SECTION (A1E102)

SYMBOL	THETA	ALPHA	MACH	BETA	PHI
○	112.500	72.000	.500	RN	.000
□	135.000				16.100
◇	157.500				
△	180.000				

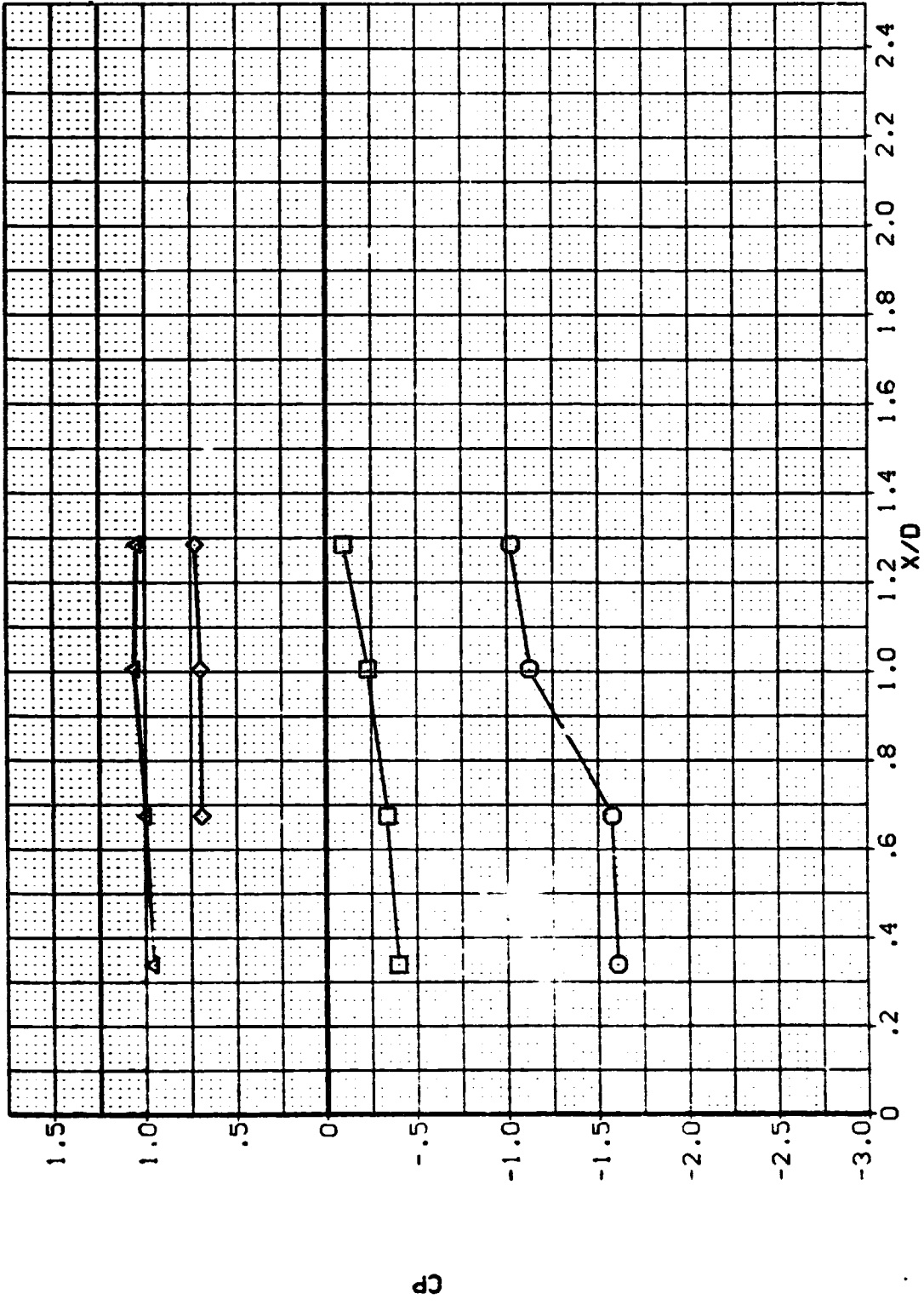

PRESSURE COEFFICIENT ALONG THE BODY AT VARIOUS POSITIONS AROUND THE BODY

MSFC HRWT 033 (SA29F) SRB FORWARD NOSE SECTION (B1E101)

SYMBOL	THETA	ALPHA	MACH	BETA	PARAMETRIC VALUES
	.000	72.100	.600	RN	.000 PHI
○	22,500				18.100
□	45,000				
◇	67,500				
△	80,000				

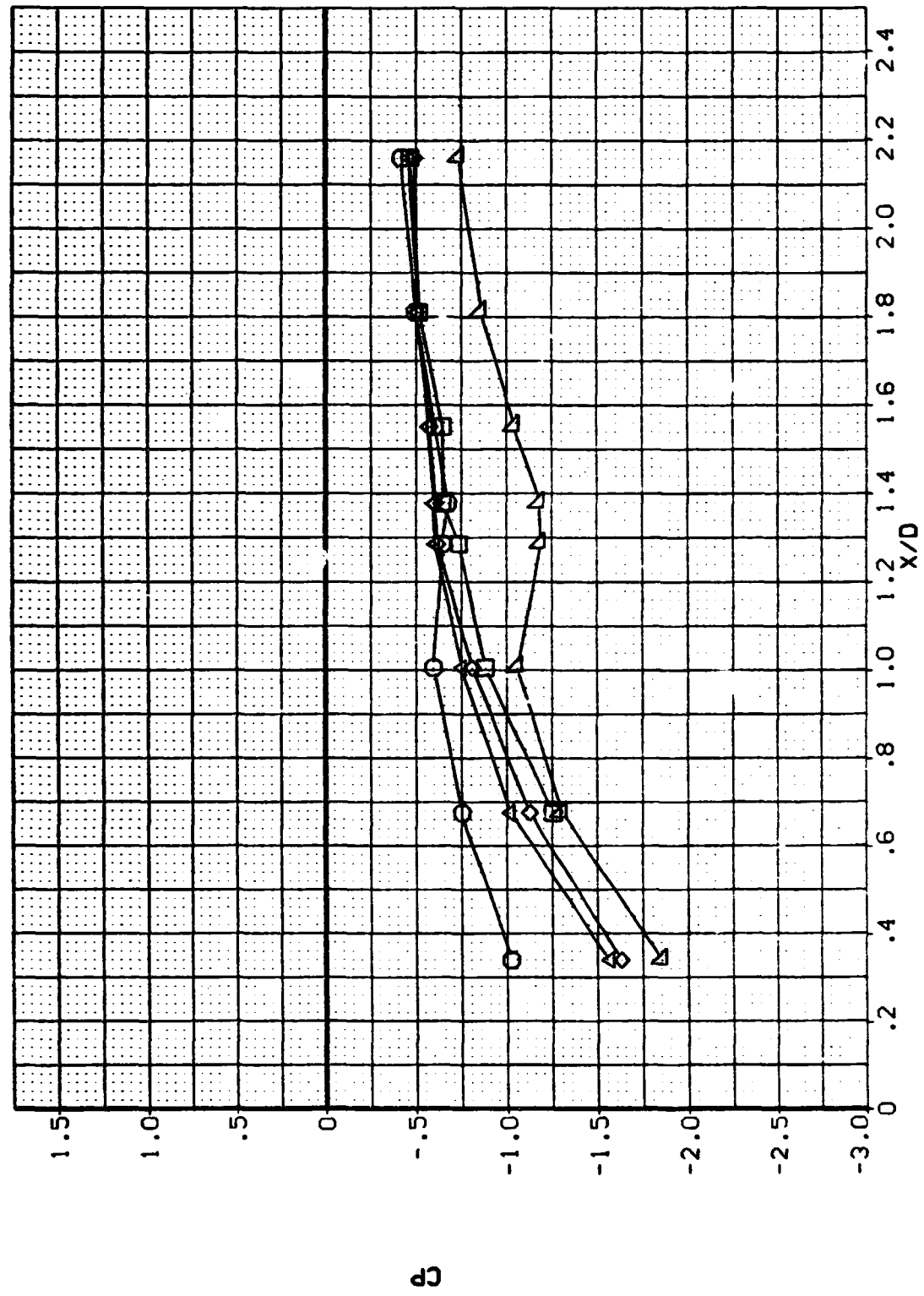

Pressure Coefficient Along the Body at Various Positions Around the Body

MSFC HRWT 033 (SA29F) SRB FORWARD NOSE SECTION (B1E101)

SYMBOL	THETA	ALPHA	MACH	BETA	PHI
○	112.500	72.100	.600	RN	.000
□	135.000				18.100
◇	157.500				
△	180.000				

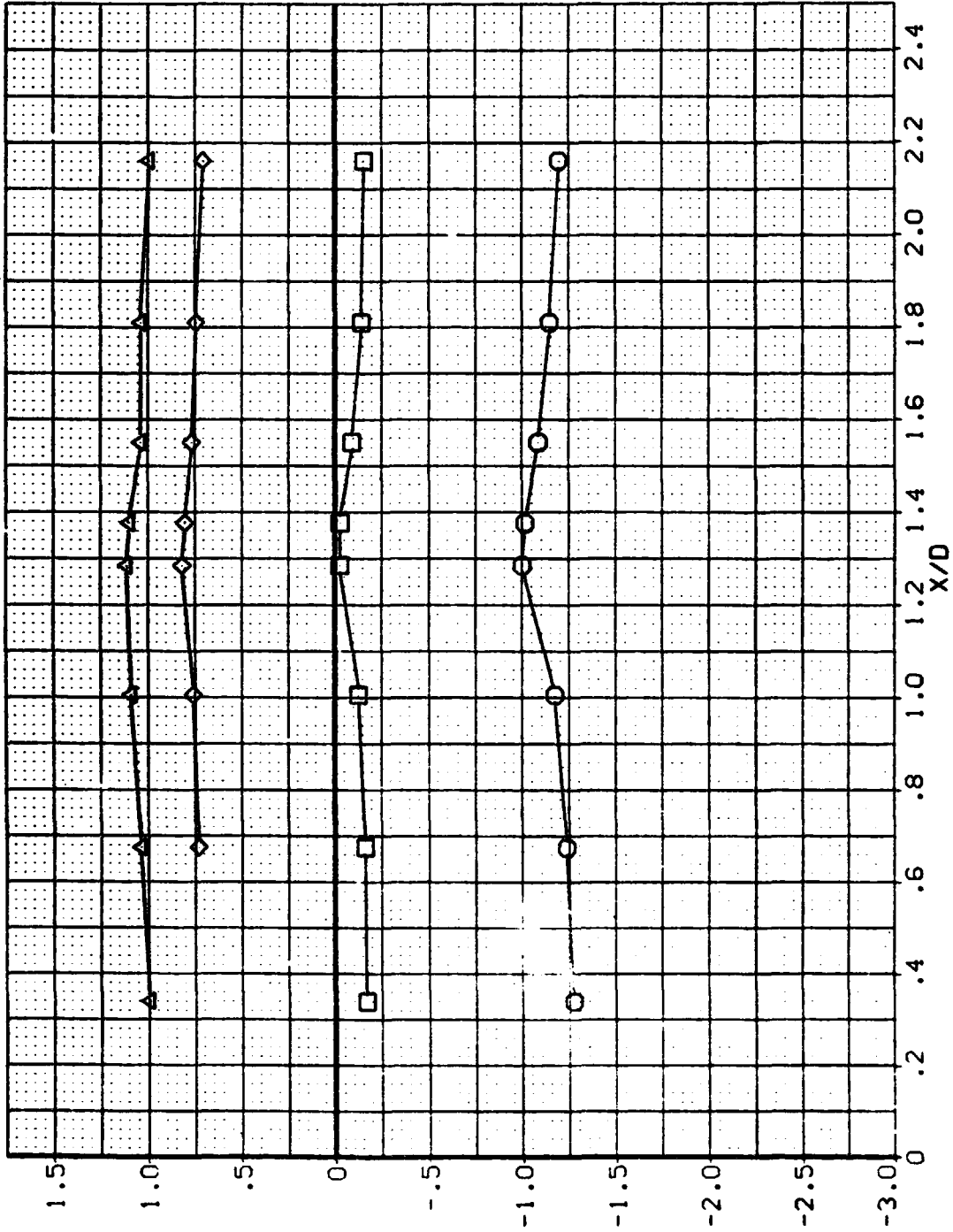

9

PRESSURE COEFFICIENT ALONG THE BODY AT VARIOUS POSITIONS AROUND THE BODY



MSFC HRWT 033 (SA29F) SRB FORWARD NOSE SECTION (B1E101)

SYMBOL
 □ ○ ◇ △

THETA .000
 22.500
 45.000
 67.500
 90.000

ALPHA 72.100
 MACH .760

BETA 18.100
 RN

PARAMETRIC VALUES
 .000 PHI
 .000

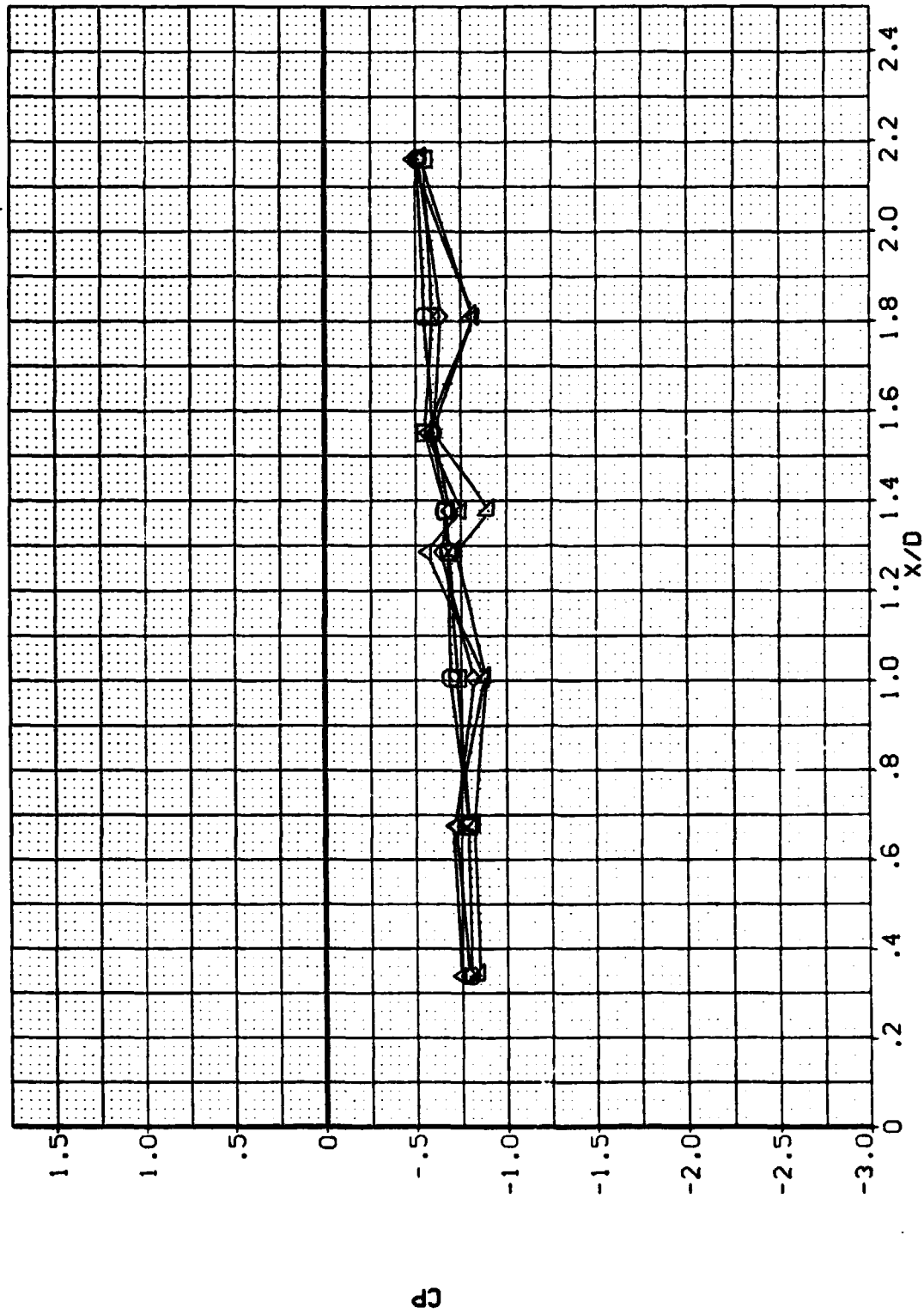

PRESSURE COEFFICIENT ALONG THE BODY AT VARIOUS POSITIONS AROUND THE BODY

MSFC HRWT 033 (SA29F) SRB FORWARD NOSE SECTION (B1E101)

SYMBOL	THETA	ALPHA	MACH	BETA	PHI
○	112.500	72.100	.760	RN	.000
□	135.000			19.100	
◇	157.500				
△	180.000				

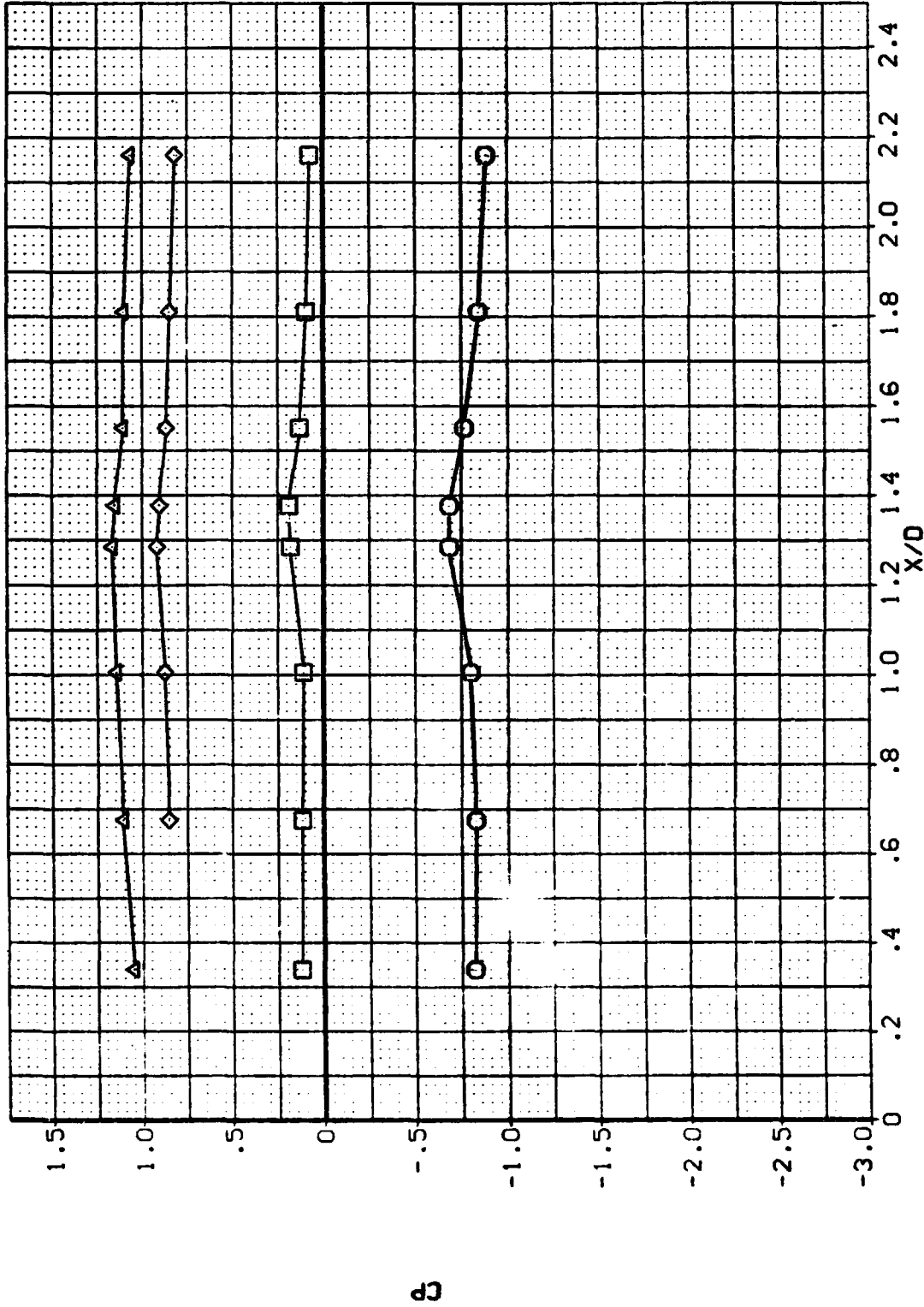

PRESSURE COEFFICIENT ALONG THE BODY AT VARIOUS POSITIONS AROUND THE BODY

MSFC LPWT 033 (SA29F) SRB FORWARD NOSE SECTION (B1E103)

PARAMETRIC VALUES
 BETA .000 PH: .000
 RN 9.000

ALPHA MACH
 72.000 2.000

THETA
 .000
 22.500
 45.000
 67.500
 90.000

SYMBOL
 □
 ◇
 △

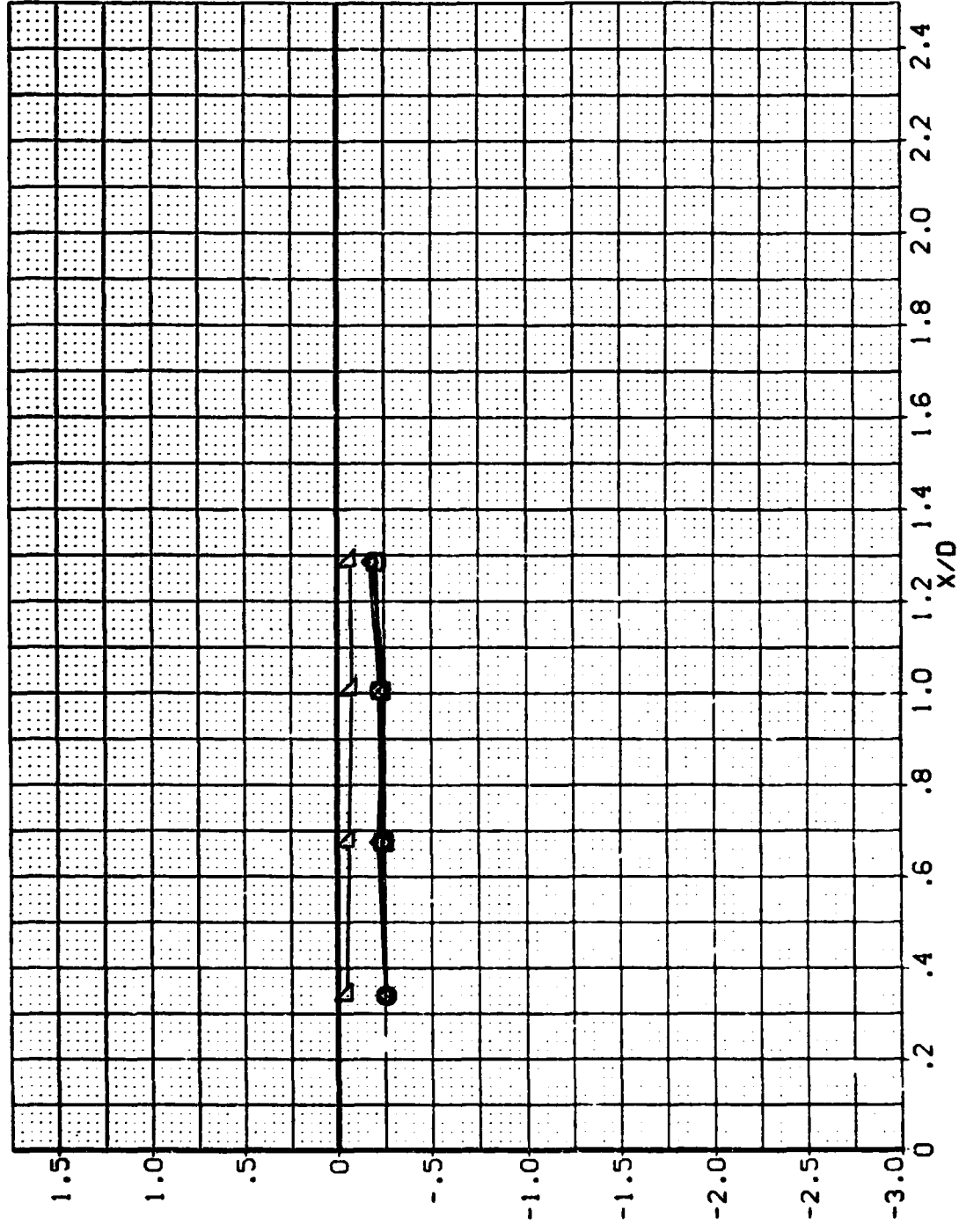

PRESSURE COEFFICIENT ALONG THE BODY AT VARIOUS POSITIONS AROUND THE BODY

MSFC HRWT 033 (SA29F) SRB FORWARD NOSE SECTION (B1E103)

SYMBOL	THETA	ALPHA	MACH	BETA	PARAMETRIC VALUES
○	112.500	72.000	2.000	RN	.000
□	135.000			RN	9.000
◇	157.500				
△	180.000				

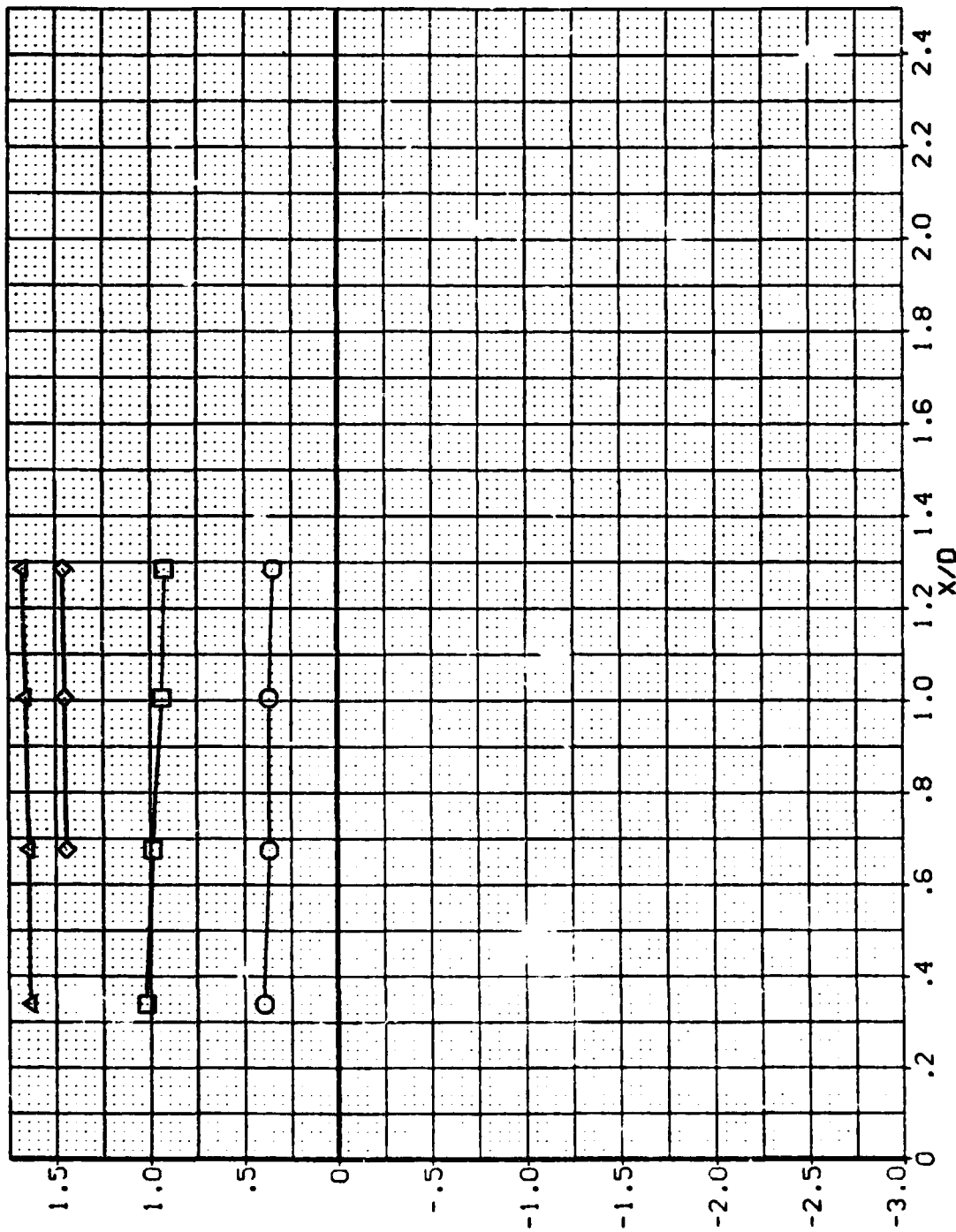

8

PRESSURE COEFFICIENT ALONG THE BODY AT VARIOUS POSITIONS AROUND THE BODY

MSFC HRWT 033 (CA29F) SR., FORWARD NOSE SECTION (B1E102)

PARAMETRIC VALUES
 BETA .000
 PHI .000
 RN 10.100

ALPHA MACH
 80.000 .510

SYMBOL
 ○ □ ◇ △

THETA
 .000
 22.500
 45.000
 67.500
 90.000

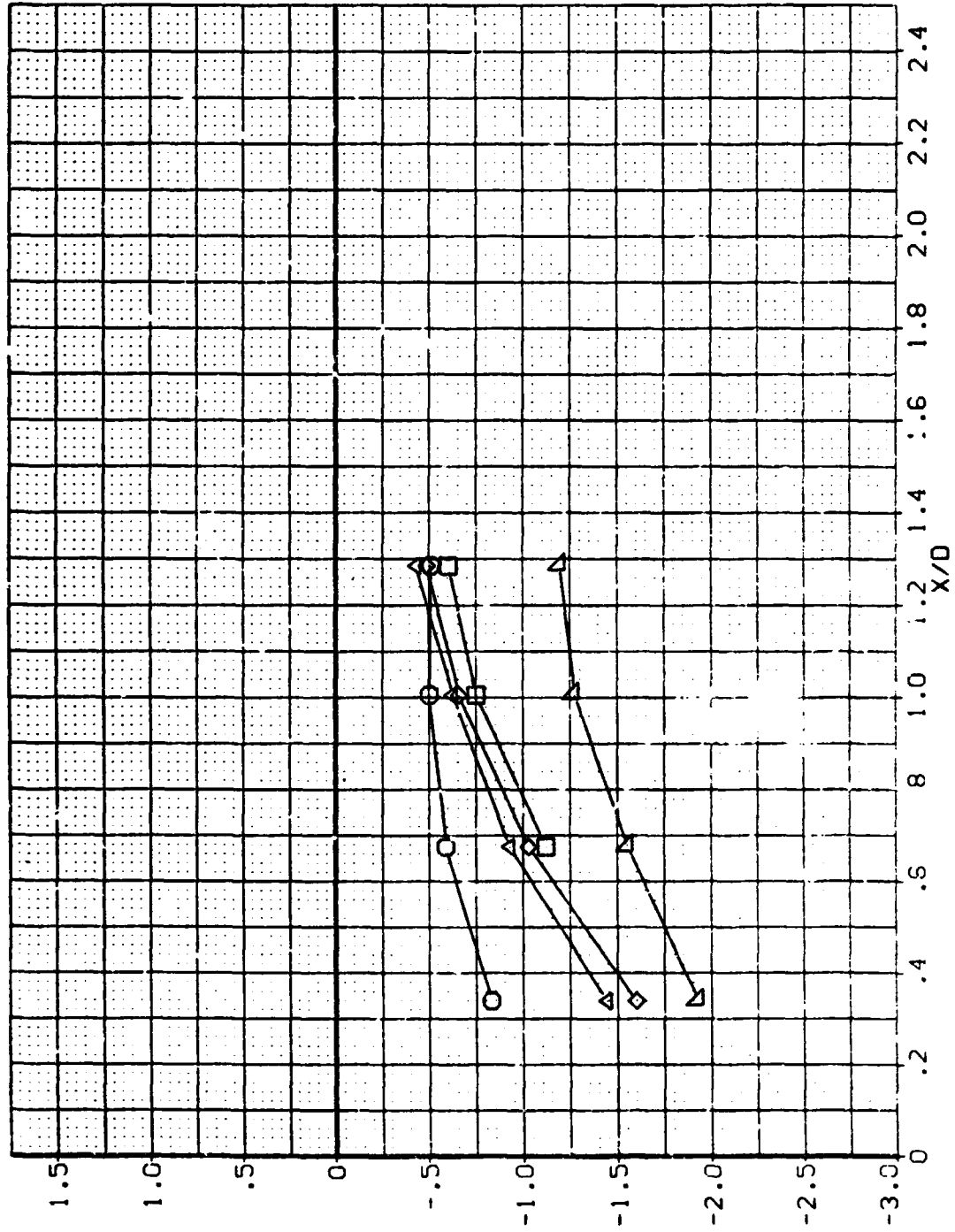

PRESSURE COEFFICIENT ALONG THE BODY AT VARIOUS POSITIONS AROUND THE BODY

MSFC HRWT 033 (SA29F) SRB FORWARD NOSE SECTION (B1E1U2)

SYMBOL	THETA	ALPHA	MACH	BETA	PHI
□	112.500	80.000	.510	16.100	.000
◇	135.000				
△	157.500				
△	180.000				

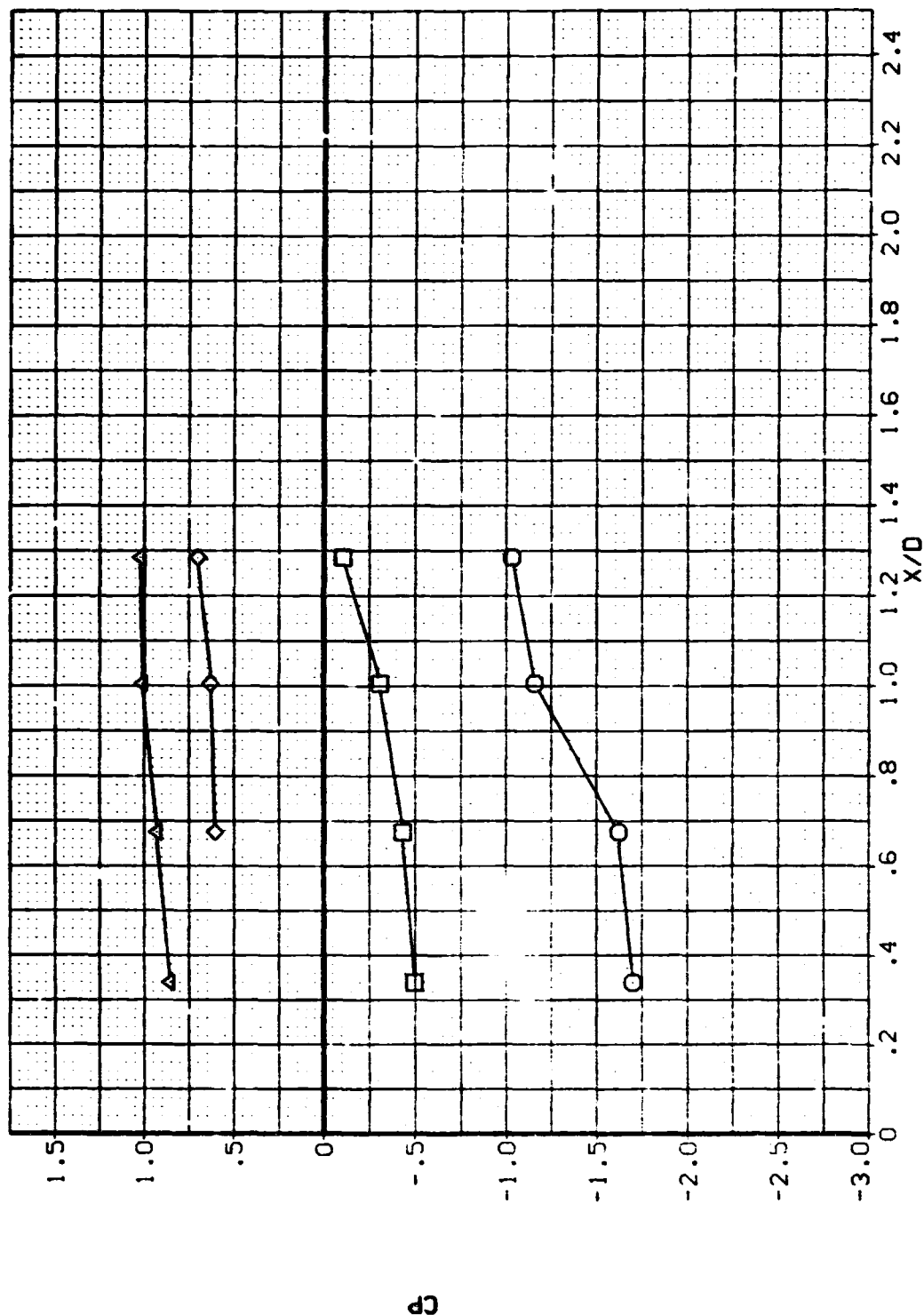

PRESSURE COEFFICIENT ALONG THE BODY AT VARIOUS POSITIONS AROUND THE BODY



MSFC HRWT 033 (S129F) SRB FORWARD NOSE SECTION (BIE102)

BYMBOL	THETA	ALPHA	MACH	BETA	PHI
	.000	80.000	.600	RN	.000
○	22.500			18.100	
□	45.000				
◇	67.500				
△	90.000				

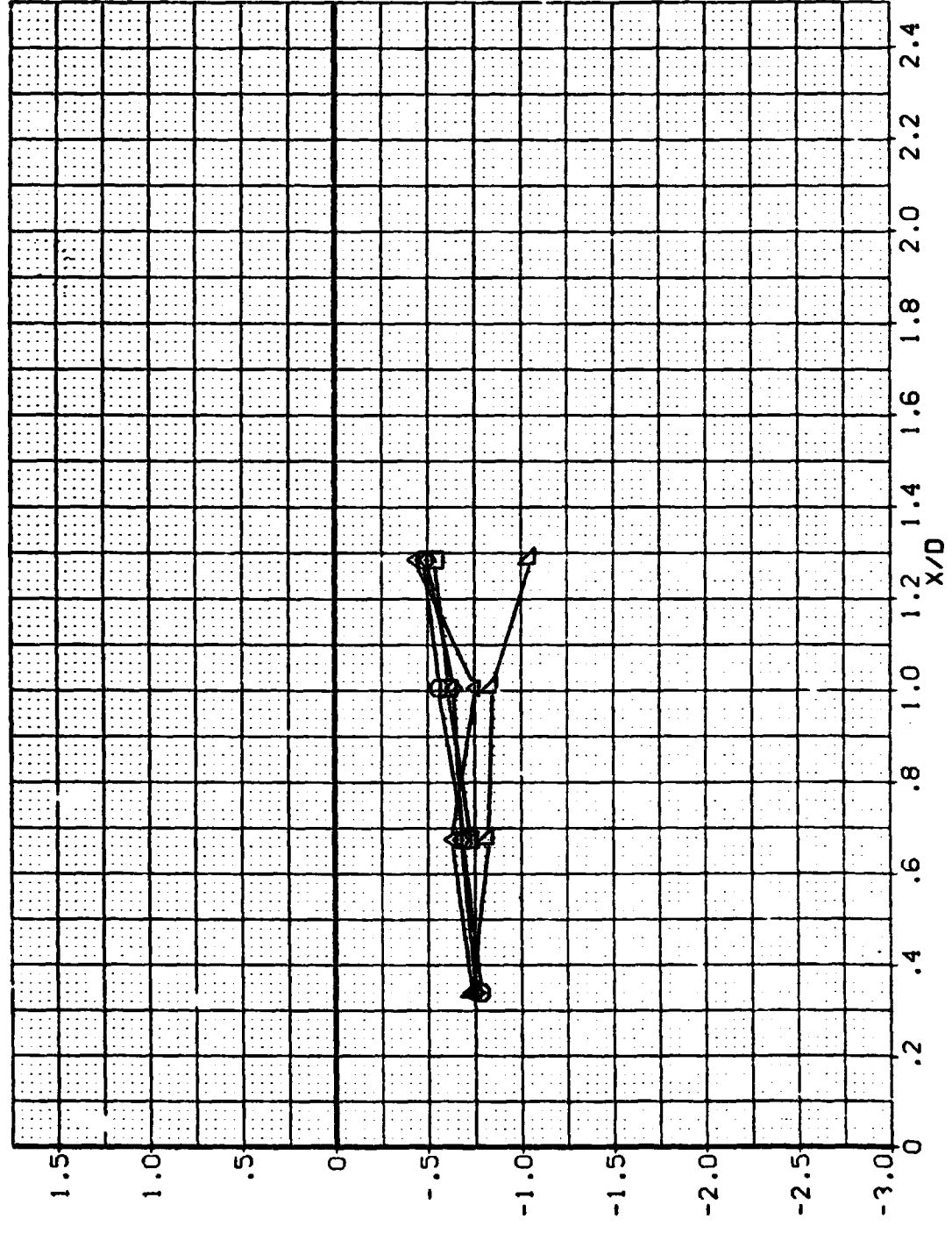

3

PRESSURE COEFFICIENT ALONG THE BODY AT VARIOUS POSITIONS AROUND THE BODY

MSFC HRWT 033 (SA29F) SRB FORWARD NOSE SECTION (B1E102)

SYMBOL	THETA	ALPHA	MACH	BETA	PHI
○	112.500	80.000	.600	RN	.000
□	135.000				18.100
◇	157.500				
△	180.000				

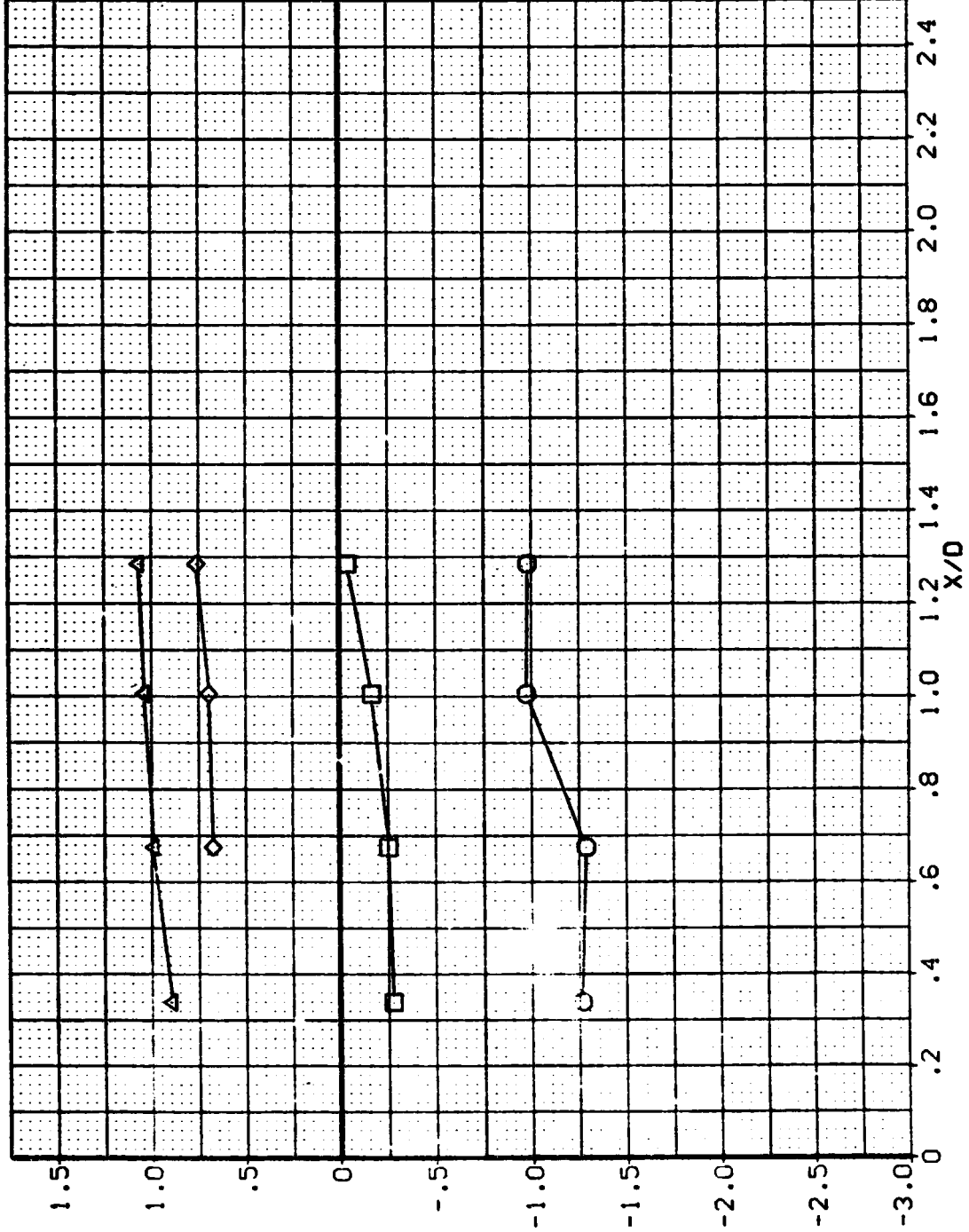

93

PRESSURE COEFFICIENT ALONG THE BODY AT VARIOUS POSITIONS AROUND THE BODY

MSFC HRWT 0J3 (S429F) SRB FORWARD NOSE SECTION (B1E102)

PARAMETRIC VALUES
 .000 PHI .000
 18.100 BETA RN

ALPHA MACH
 80.000 .790

THETA
 .000
 22.500
 45.000
 67.500
 90.000

SYMBOL
 □ ◇ ▲

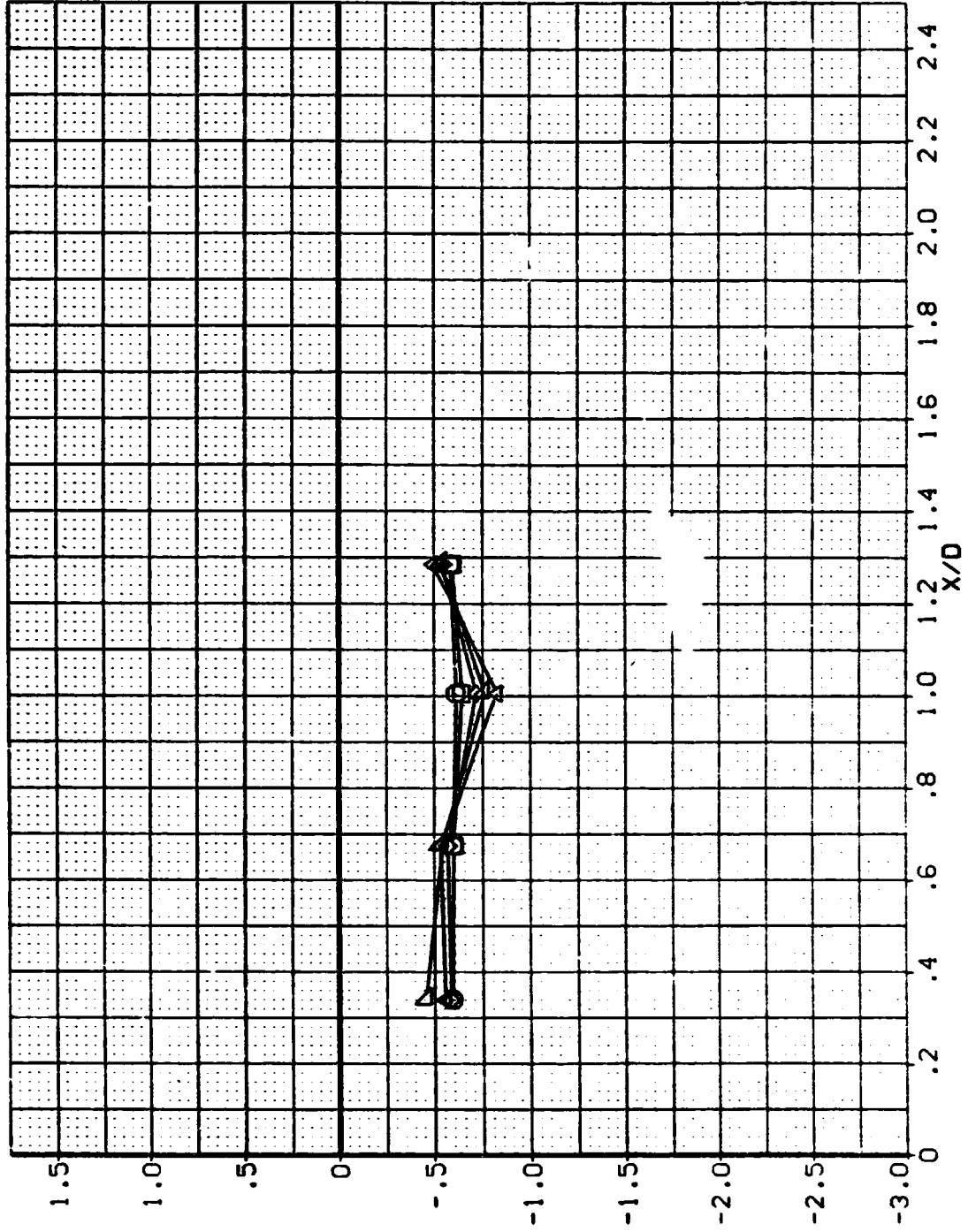

PRESSURE COEFFICIENT ALONG THE BODY AT VARIOUS POSITIONS AROUND THE BODY

MSFC HRWT 033 (SA29F) SRB FORWARD NOSE SECTION (B1E102)

SYMBOL	THETA	ALPHA	MACH	BETA	PARAMETRIC VALUES
○	112.500	60.000	.790	RN	.000 PHI
□	135.000				18.100
◇	157.500				
△	180.000				

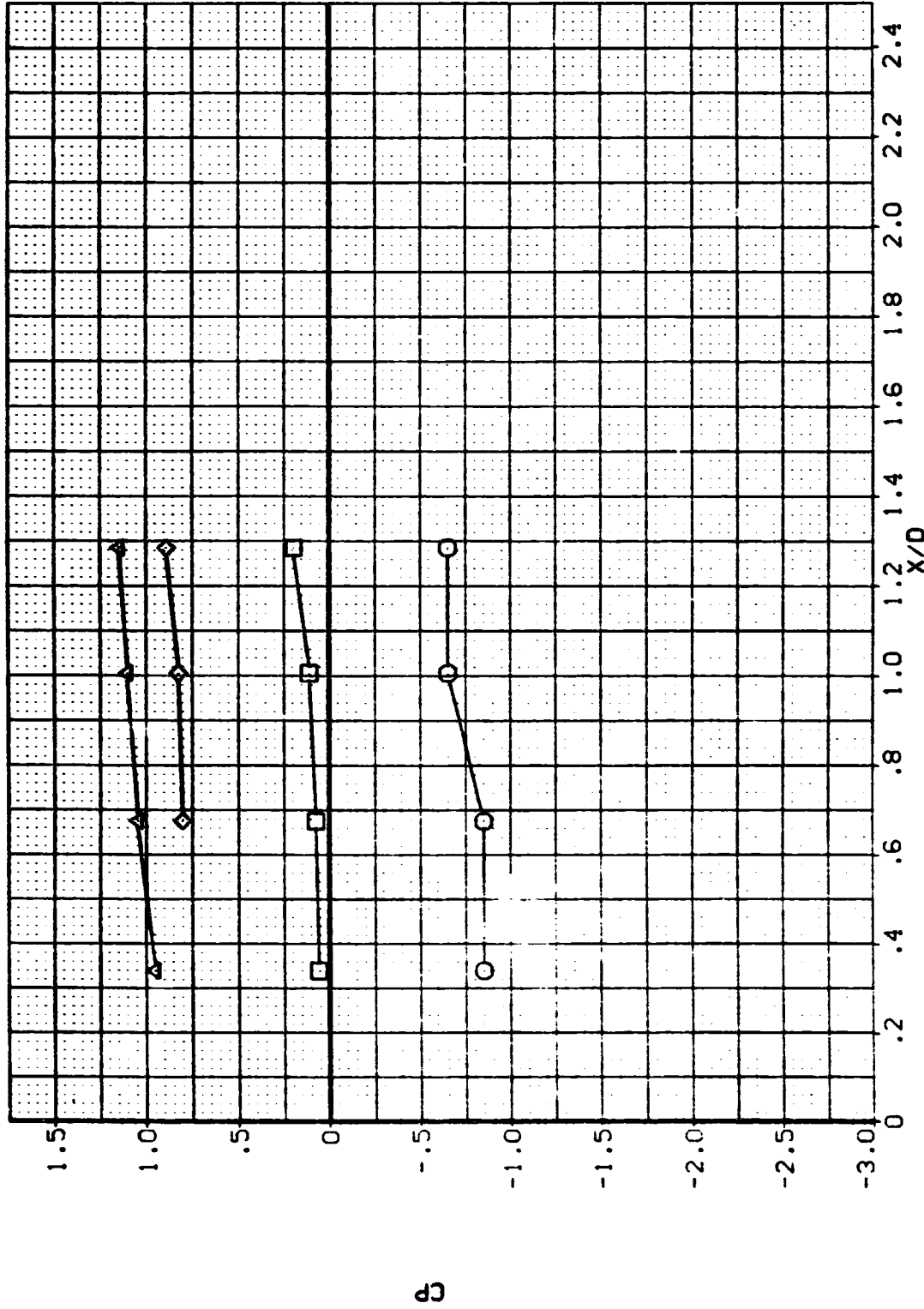

PRESSURE COEFFICIENT ALONG THE BODY AT VARIOUS POSITIONS AROUND THE BODY

MSFC HRWT 033 (SA29F) SRB FORWARD NOSE SECTION (C1E103)

SYMBOL	THETA	ALPHA	MACH	BETA	PARAMETRIC VALUES
□	.000	60.000	2.000	RN	.000 PHI
◇	22.500				8.000
◇	45.000				
△	67.500				
△	90.000				

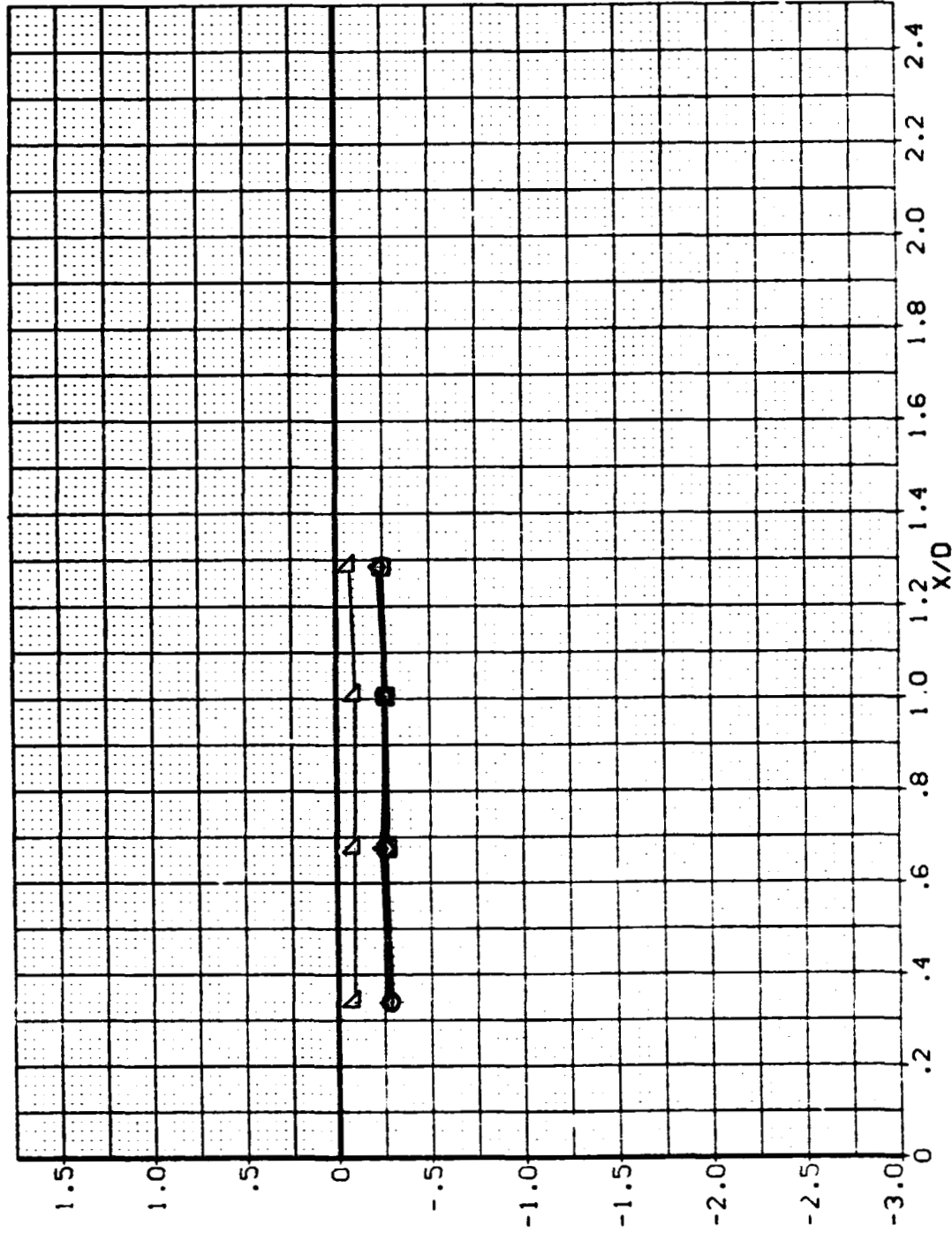

3

PRESSURE COEFFICIENT ALONG THE BODY AT VARIOUS POSITIONS AROUND THE BODY

MSFC HRWT 033 (SA29F) SRB FORWARD NOSE SECTION (C1E103)

SYMBOL	THETA	ALPHA	MACH	BETA	PHI
○	112.500	60.000	2.000	9.000	.000
□	135.000				
◇	157.500				
△	180.000				

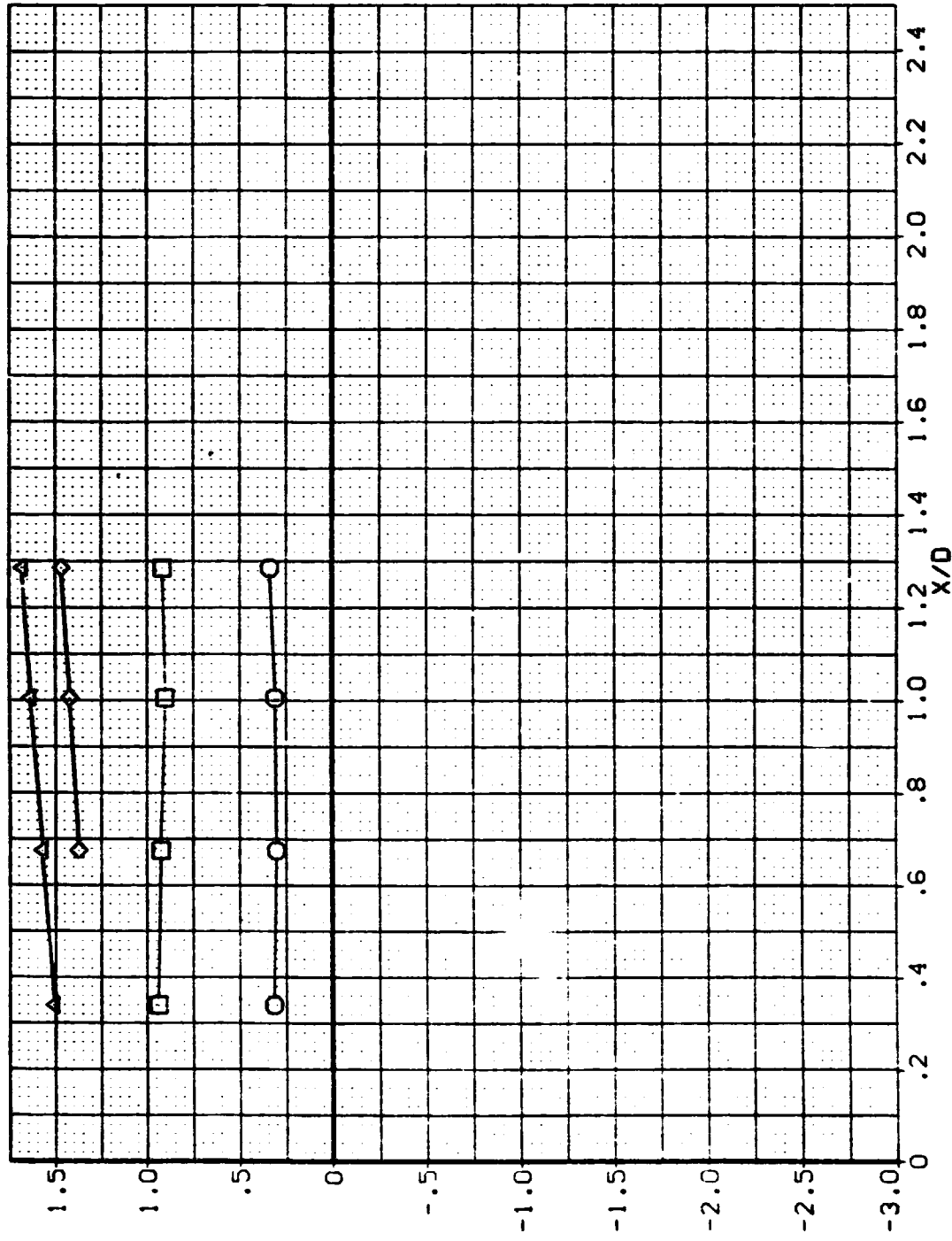

93

PRESSURE COEFFICIENT ALONG THE BODY AT VARIOUS POSITIONS AROUND THE BODY

MSFC HRWT 033 (SA29F) SRB FORWARD NOSE SECTION (C1E101)

THETA .000 ALPHA 90.000 MACH .400
 22.500
 45.000
 67.500
 90.000

BETA RN
 .000
 18.100

PARAMETRIC VALUES
 .000 PHI
 .000

SYMBOL
 ○ □ ◇ △

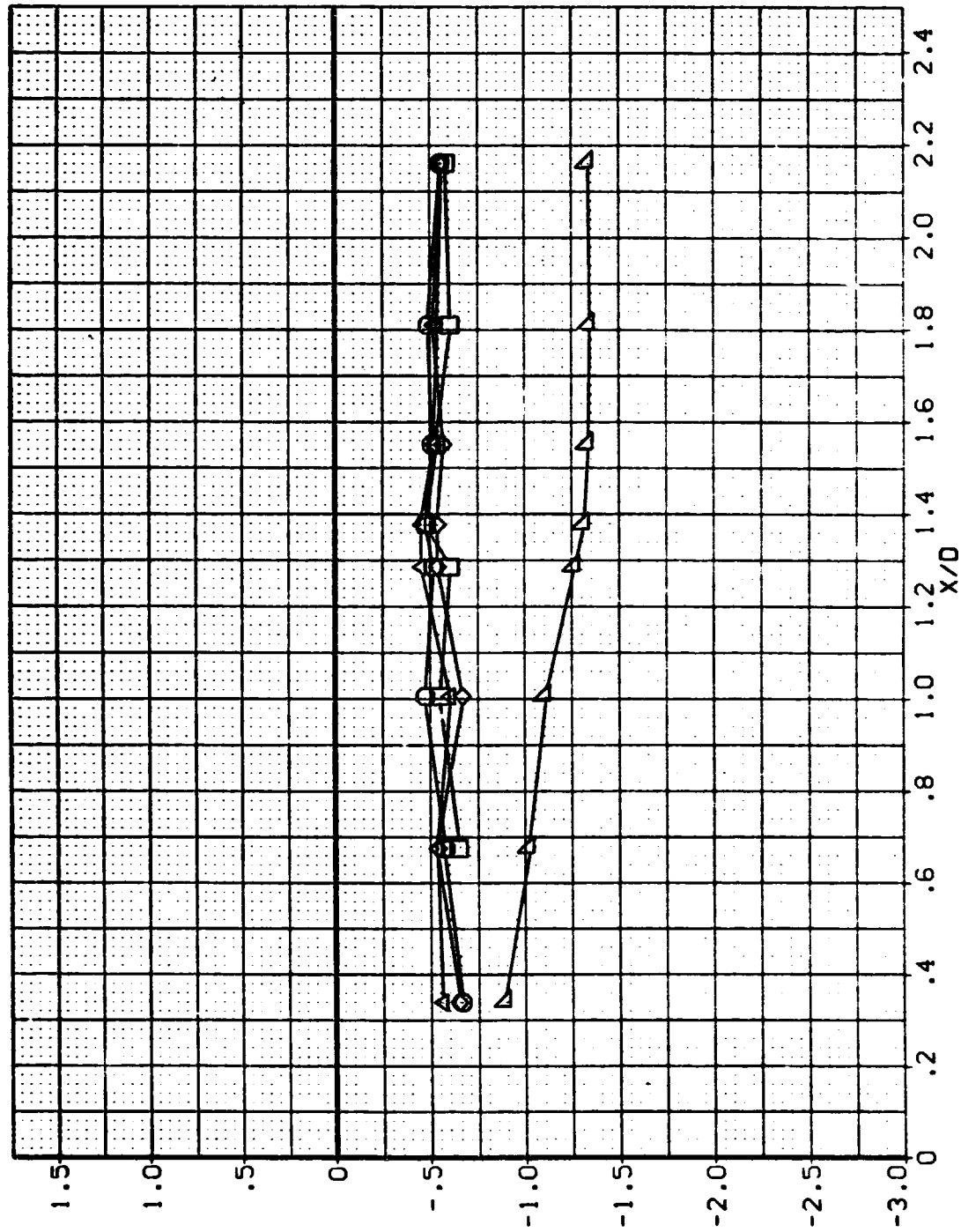

93

MSFC HRWT 033 (SA29F) SRB FORWARD NOSE SECTION (C1E101)

SYMBOL	THETA	ALPHA	MACH	BETA	PARAMETRIC VALUES
○	112.500	90.000	.400	RN	.000 PHI
□	135.000				18.100
◇	157.500				
△	180.000				

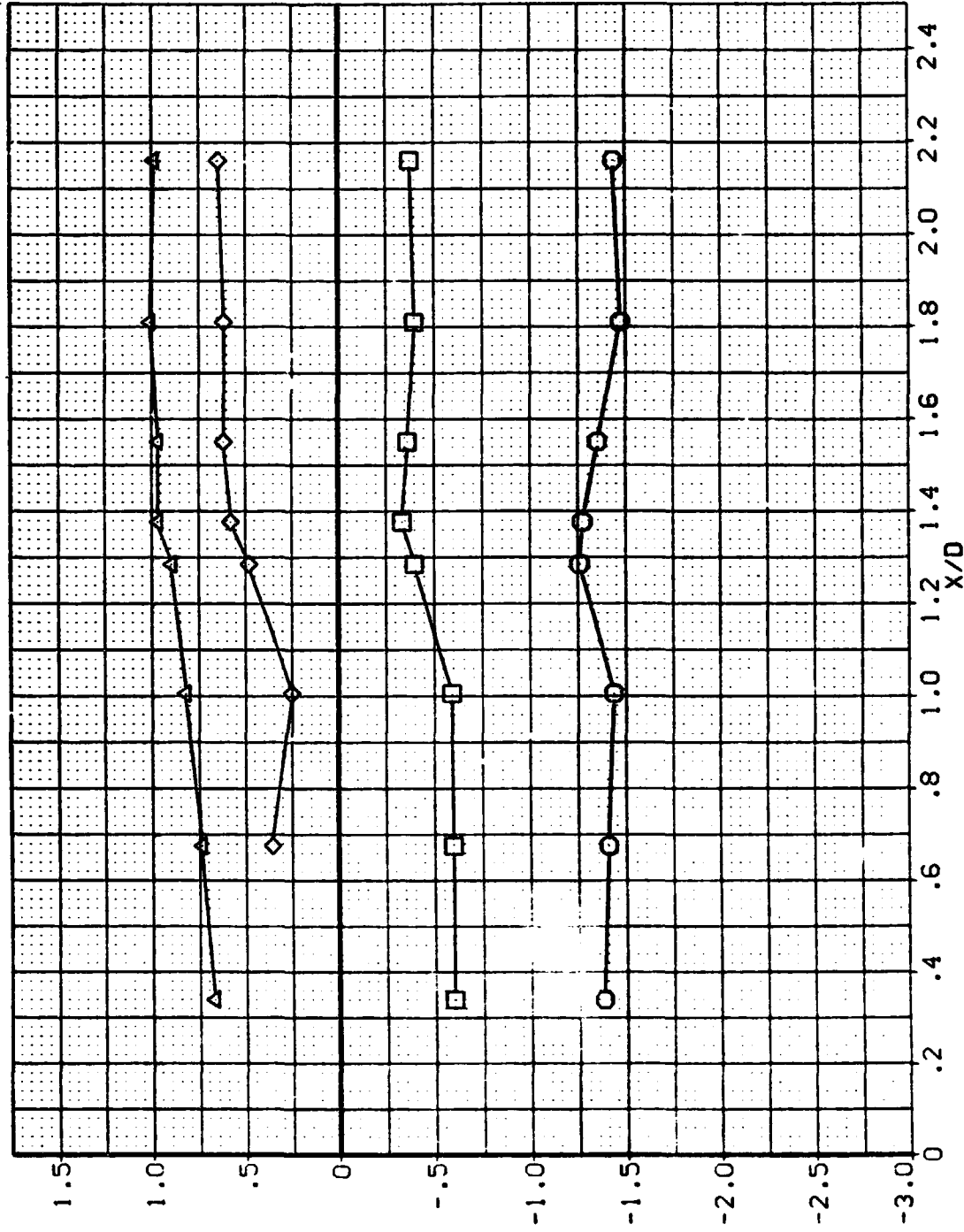

95

PRESSURE COEFFICIENT ALONG THE BODY AT VARIOUS POSITIONS AROUND THE BODY

MSFC HRWT 033 (SA29F) SRB FORWARD NOSE SECTION (C1E102)

PARAMETRIC VALUES
 .000 PM1
 .000
 BETA RN
 18.100

ALPHA EACH
 90.000 .490

THETA
 .000
 22.500
 45.000
 67.500
 90.000

SYMBOL
 ○ □ ◇ △

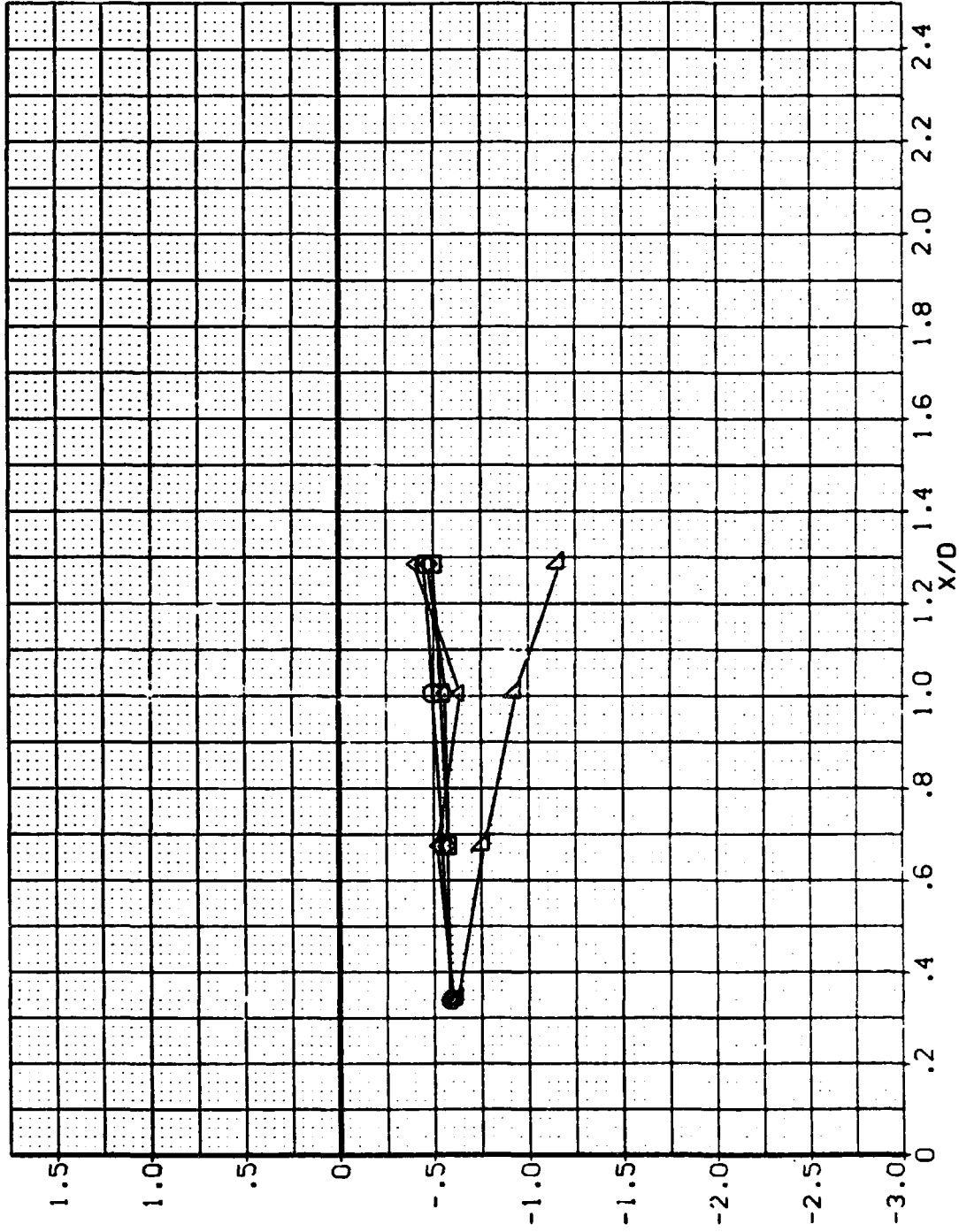

PRESSURE COEFFICIENT ALONG THE BODY AT VARIOUS POSITIONS AROUND THE BODY

MSFC HRWT 033 (SA29F) SRB FORWARD NOSE SECTION (C1E102)

SYMBOL	THETA	ALPHA	MACH	BETA	PARAMETRIC VALUES
○	112.500	90.000	.490	RN	.000 PMJ
□	135.000				19.100
◇	157.500				
△	180.000				

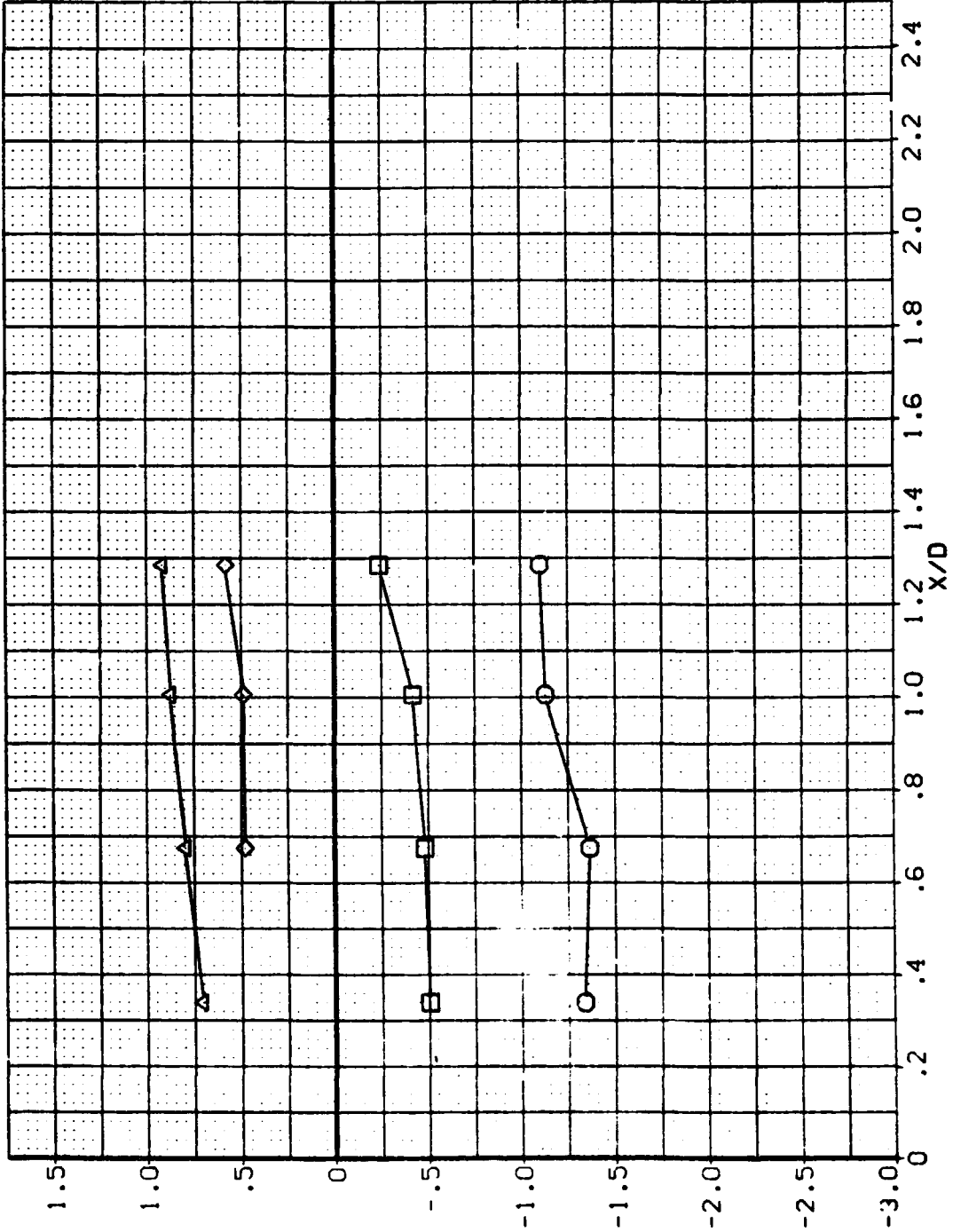

93

PRESSURE COEFFICIENT ALONG THE BODY AT VARIOUS POSITIONS AROUND THE BODY

MSFC HRWT 033 (SA29F) SRB FORWARD NOSE SECTION (D1E101)

THETA .000 ALPHA 90.000 MACH .600
 22.500
 45.000
 67.500
 90.000

BETA RN
 18.100

PARAMETRIC VALUES
 .000 PHI .000

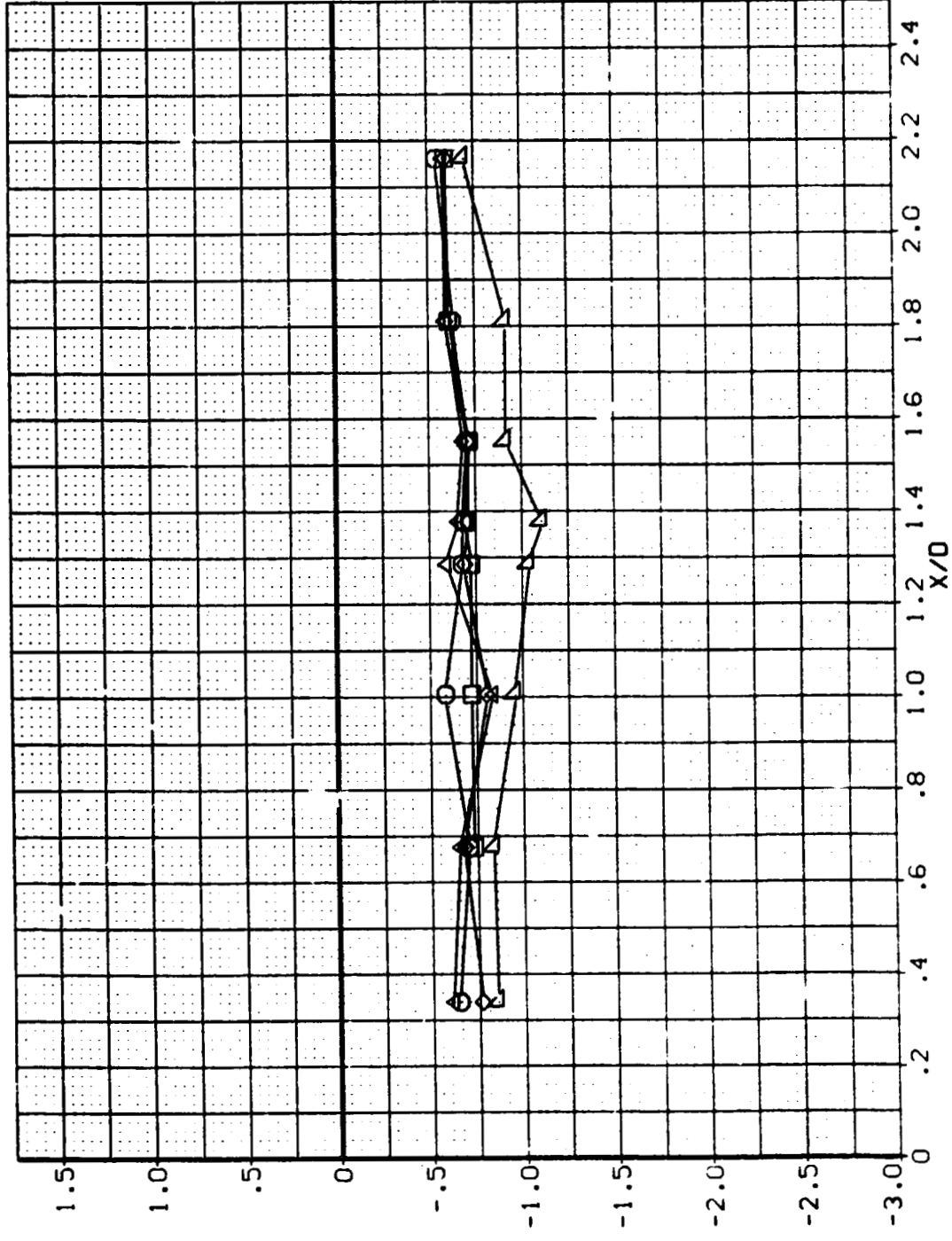

93

PRESSURE COEFFICIENT ALONG THE BODY AT VARIOUS POSITIONS AROUND THE BODY

MSFC HRWT 033 (SA29F) SRB FORWARD NOSE SECTION (DIE101)

SYMBOL	THETA	ALPHA	MACH	BETA	PHI
○	112.500	90.000	.600	RN	.000
□	135.000			18.100	
◇	157.500				
△	180.000				

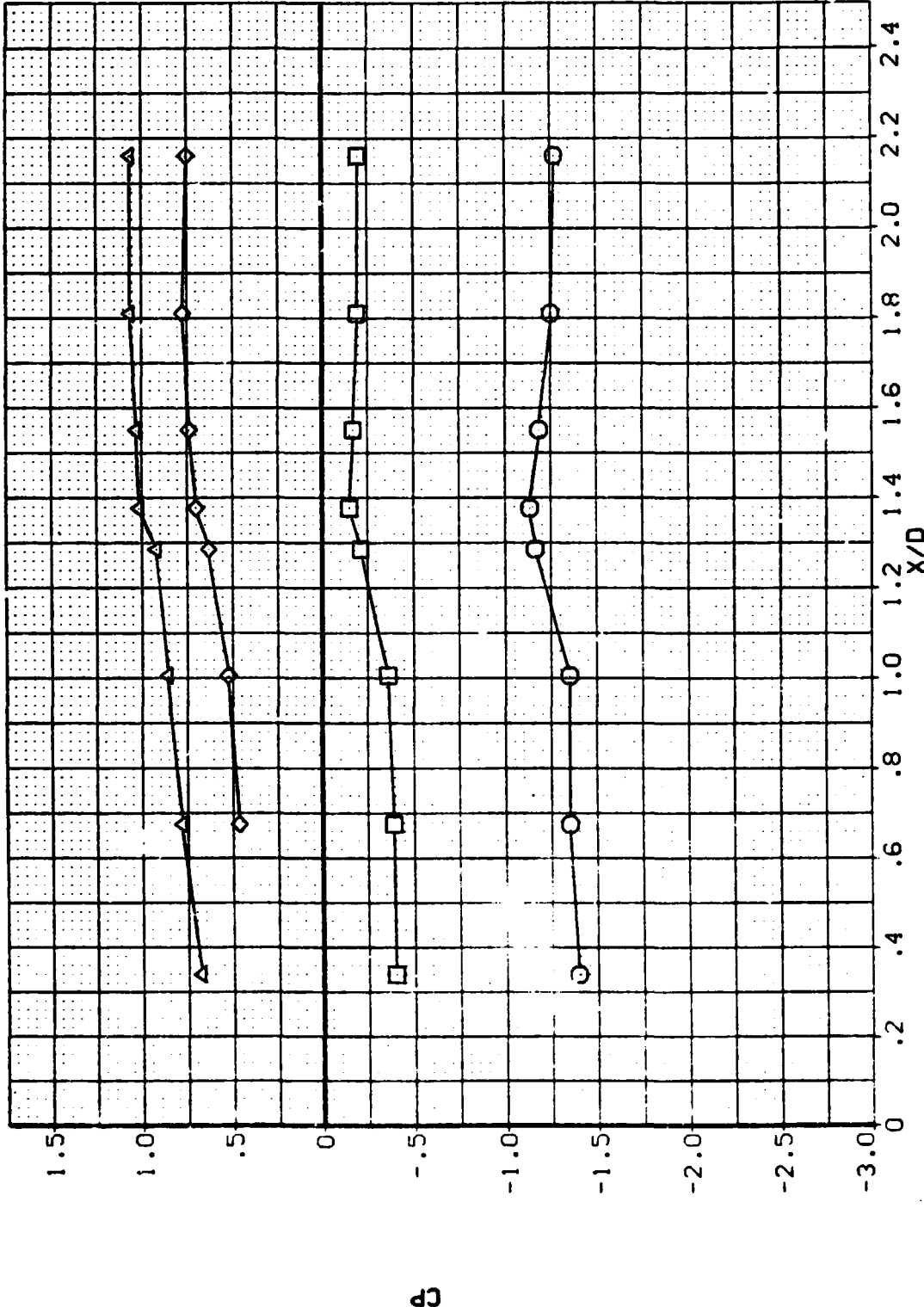

PRESSURE COEFFICIENT ALONG THE BODY AT VARIOUS POSITIONS AROUND THE BODY

MSFC HRWT 033 (SA29F) SR6 FORWARD NOSE SECTION (D1E101)

PARAMETRIC VALUES
 .000 PHI
 .000

BETA
 RN 18.100

MACH
 .780

ALPHA
 90.000

THETA
 .000
 22.500
 45.000
 67.500
 90.000

SYMBOL
 ○ □ ◇ △

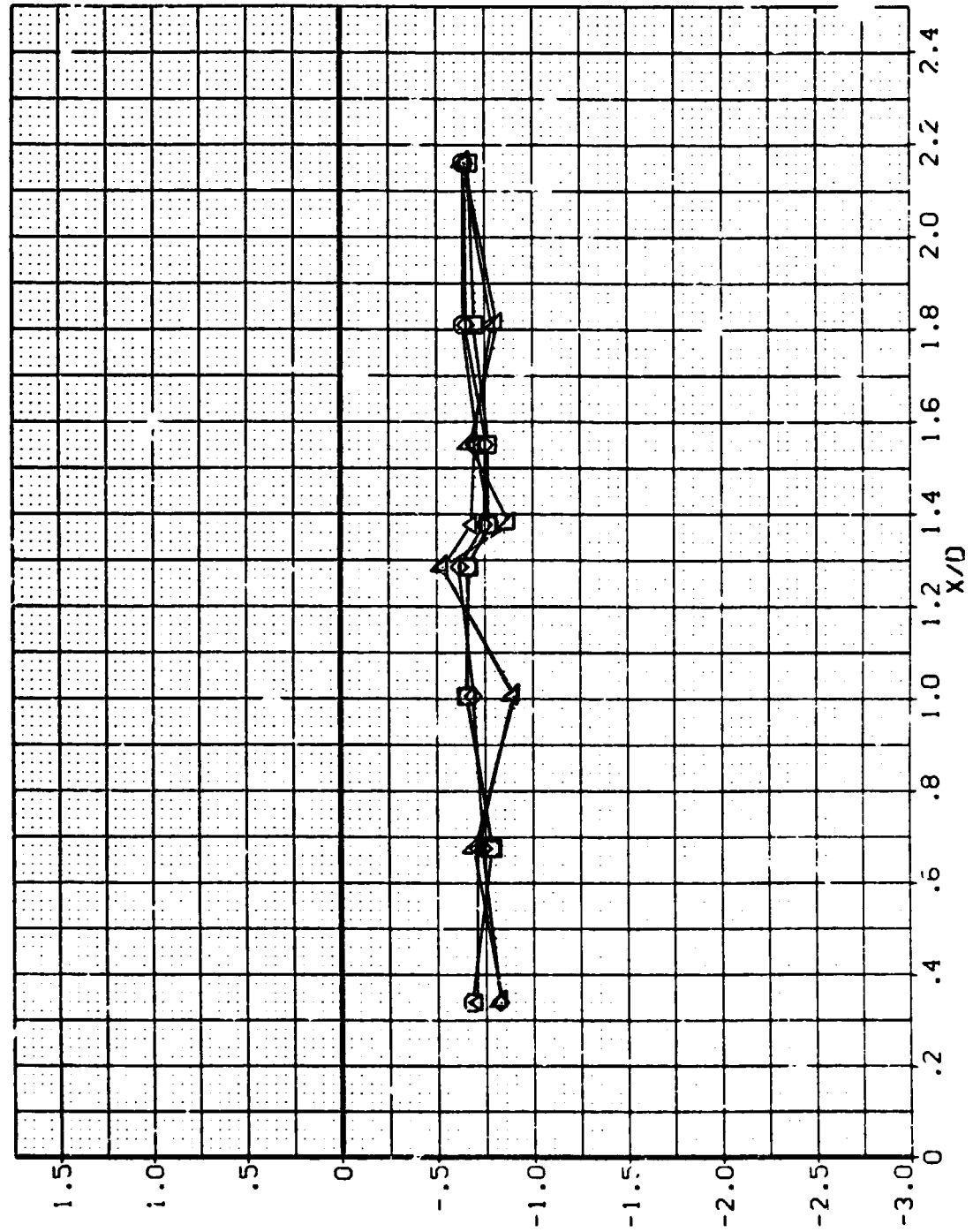

3

PRESSURE COEFFICIENT ALONG THE BODY AT VARIOUS POSITIONS AROUND THE BODY

MSFC HRWT 033 (SA29F) SRB FORWARD NOSE SECTION (DIE101)

SYMBOL	THETA	ALPHA	MACH	BETA	PARAMETRIC VALUES
○	112.500	90 °00	.780	RN	.000 PHI
□	135.000				.000
◇	157.500				18.100
△	180.000				

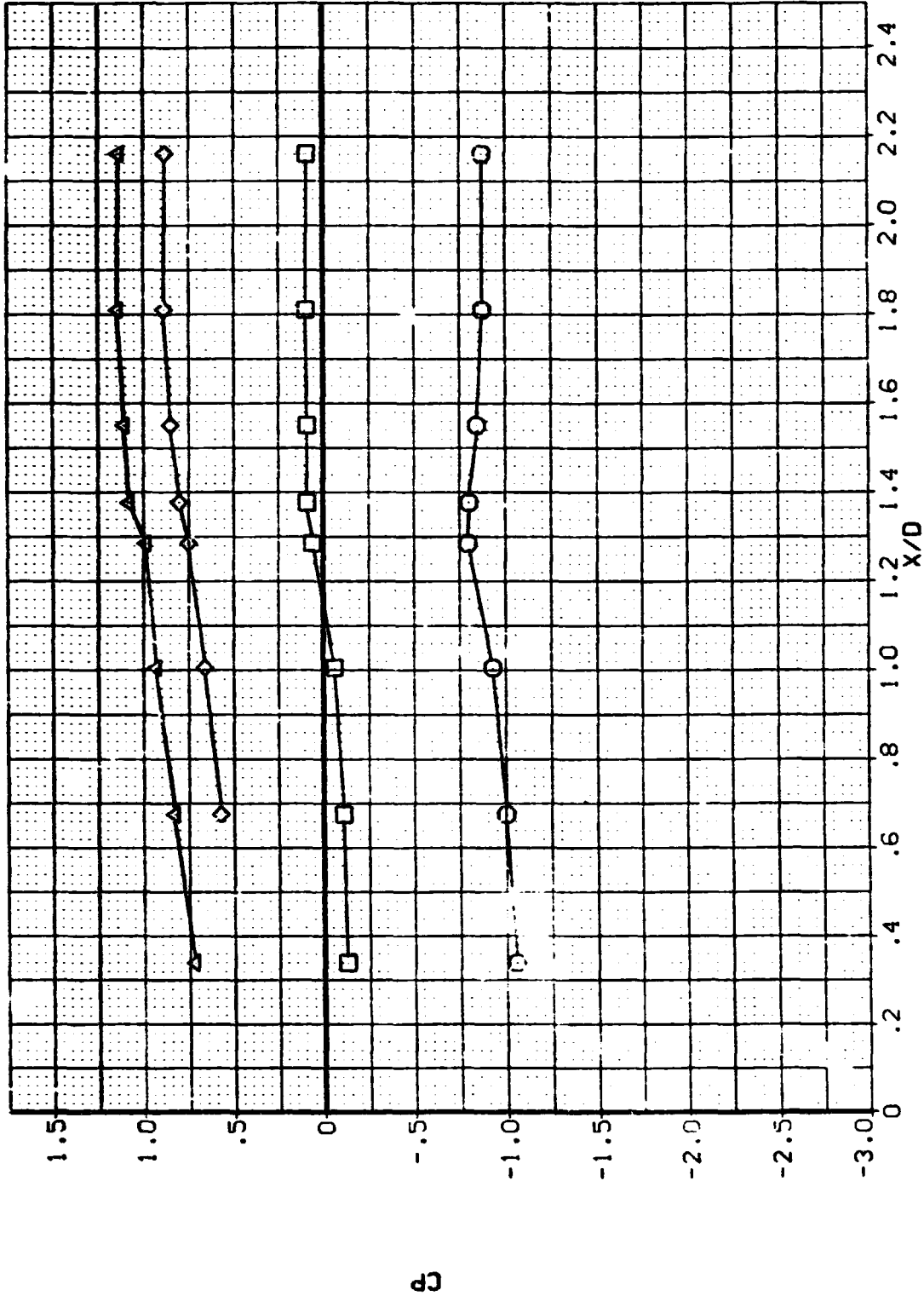

PRESSURE COEFFICIENT ALONG THE BODY AT VARIOUS POSITIONS AROUND THE BODY

MSFC HWRT 033 (S_A29F) SRB FORWARD NOSE SECTION (D1E103)

SYMBOL	THETA	ALPHA	MACH	BETA	PHI
□	.000	90.000	2.000	.RN	.000
◇	22.500				9.000
◇	45.000				
△	67.500				
△	90.000				

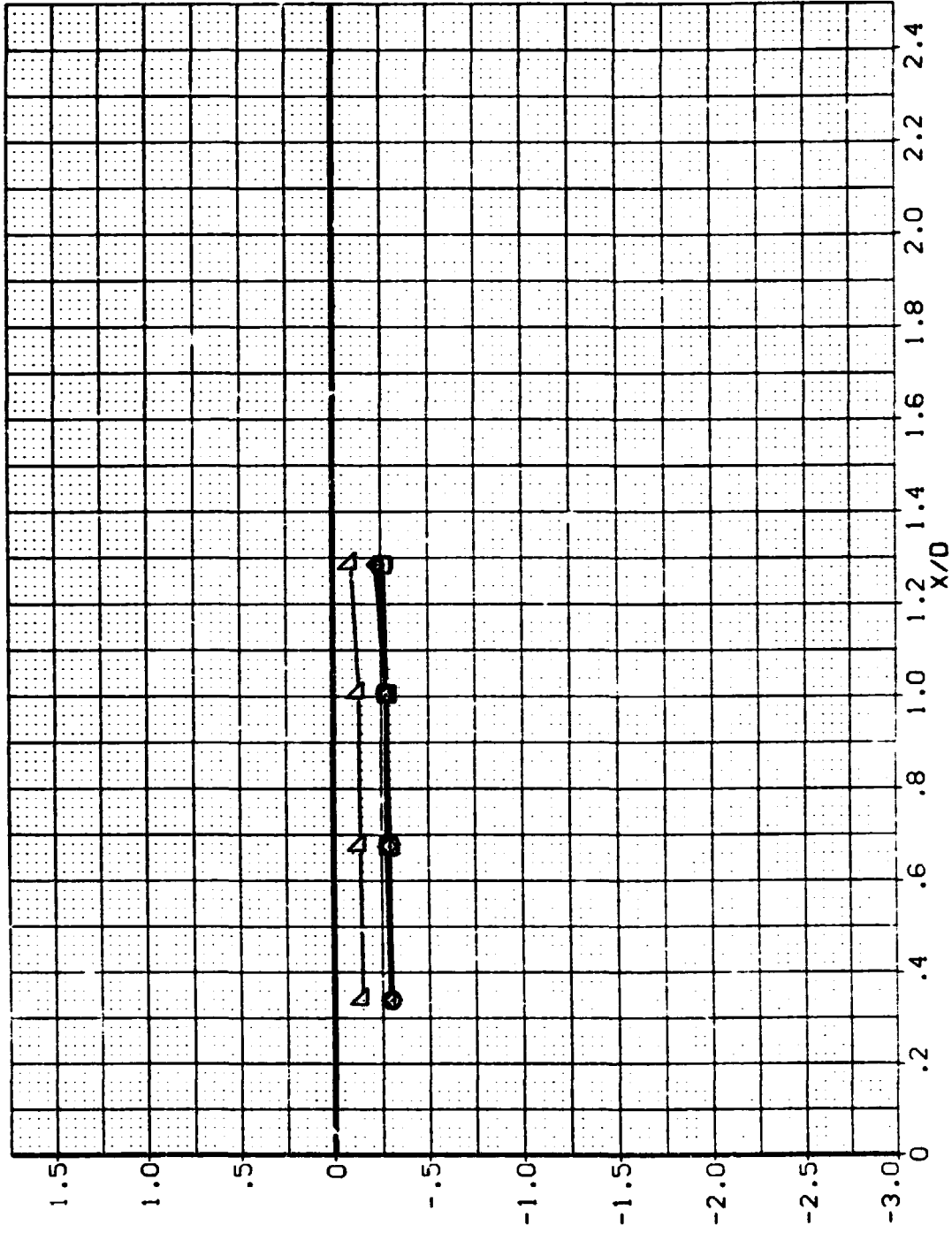

PRESSURE COEFFICIENT ALONG THE BODY AT VARIOUS POSITIONS AROUND THE BODY

3

MSFC HRWT 033 (SA29F) SRB FORWARD NOSE SECTION (DIE103)

SYMBOL	THETA	ALPHA	MACH	BETA	PARAMETRIC VALUES
○	112.500	90.000	2.000	RN	.000 PHI
□	135.000				9.000
◇	157.500				
△	180.000				

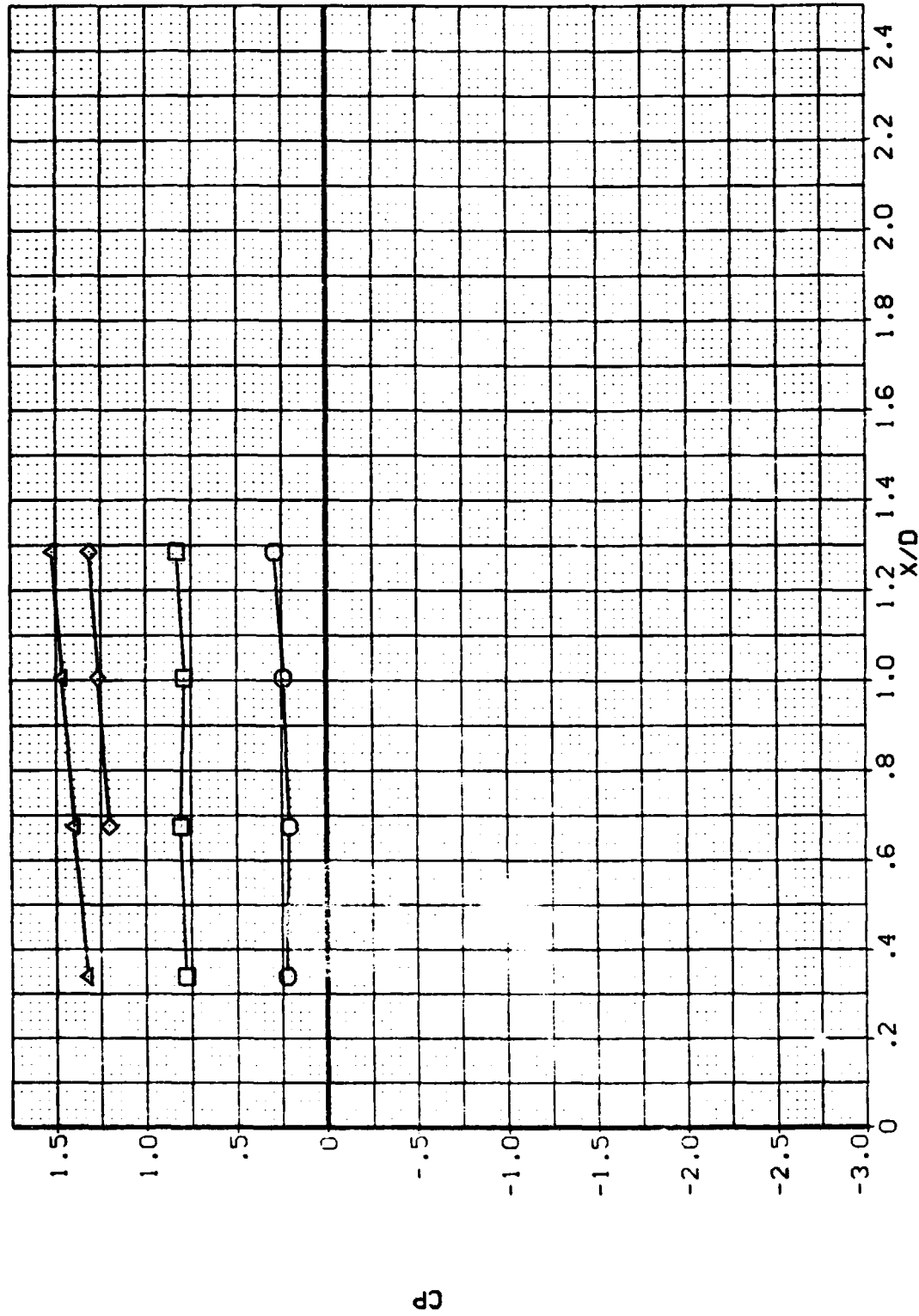

PRESSURE COEFFICIENT ALONG THE BODY AT VARIOUS POSITIONS AROUND THE BODY

MSFC HRWT 033 (SA29F) SRB FORWARD NOSE SECTION (D1E102)

PARAMETRIC VALUES
 .000 PHI
 18.100

BETA
 RN

ALPHA
 100.000
 .500

THETA
 .000
 22.500
 45.000
 67.500
 90.000

SYMBOL
 □ ◇ ◊ ▲

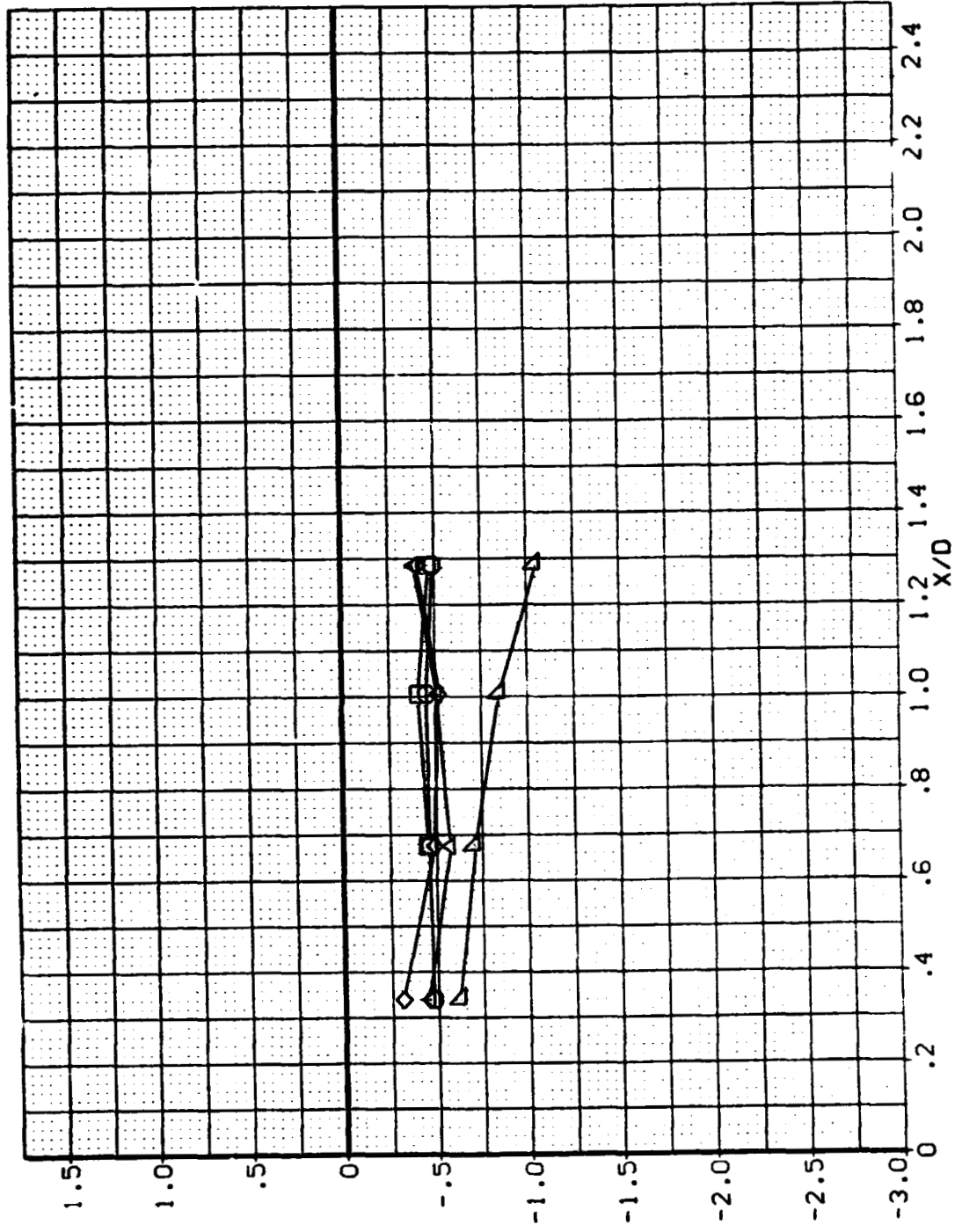

83

PRESSURE COEFFICIENT ALONG THE BODY AT VARIOUS POSITIONS AROUND THE BODY

MSFC HRWT 033 (SA29F) SRB FORWARD NOSE SECTION (D1E102)

SYMBOL	THETA	ALPHA	MACH	BETA	PARAMETRIC VALUES
○	112.500	100.000	.500	RN	.000 PH: .000
□	135.000				
◇	157.500				
△	180.000				

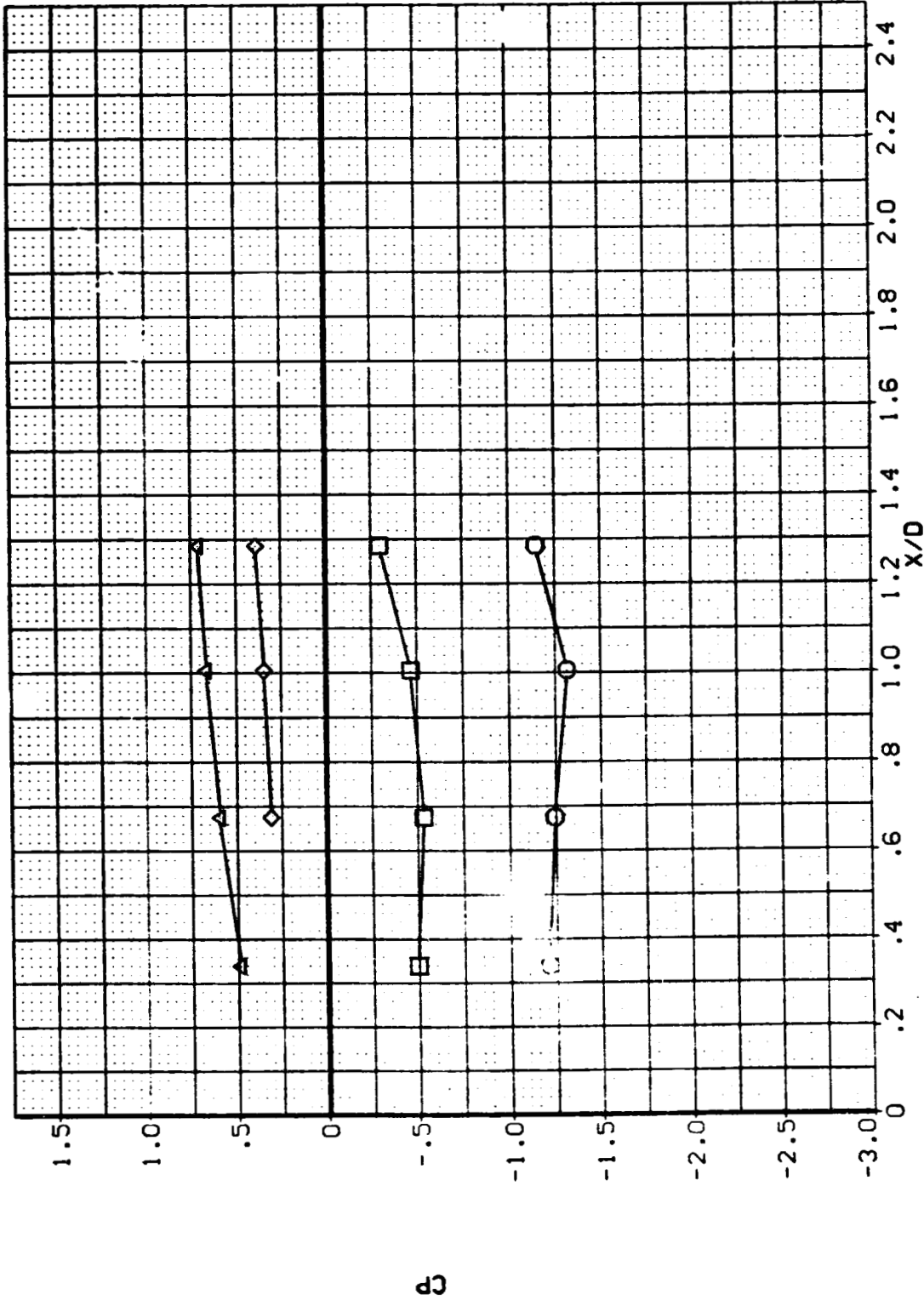

PRESSURE COEFFICIENT ALONG THE BODY AT VARIOUS POSITIONS AROUND THE BODY PAGE 30

MSFC HRW i J33 (SA29F) SRB FORWARD NOSE SECTION (OIE102)

THETA .000 ALPHA 100.000 MACH .600
 22.500
 45.000
 67.500
 90.000

BETA RN 18.100
 PHI .000

SYMBOL
 □ ◇ △

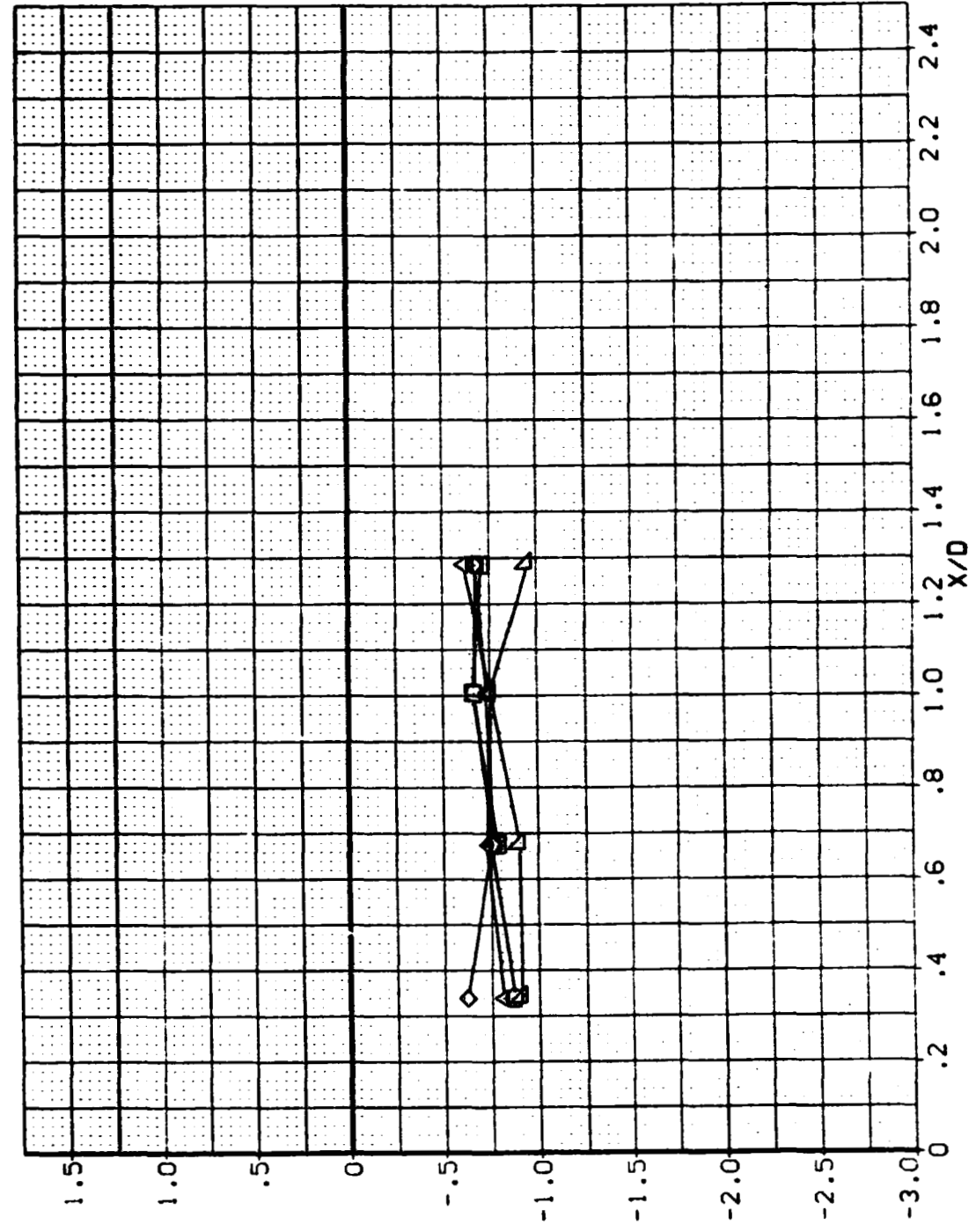

PRESSURE COEFFICIENT ALONG THE BODY AT VARIOUS POSITIONS AROUND THE BODY

MSFC HRWT 033 (SA29F) SRB FORWARD NOSE SECTION (D1E102)

SYMBOL	THETA	ALPHA	MACH	BETA	PARAMETRIC VALUES
□	112.500	100.000	.600	RN	.000 PHI
◇	135.000				18.100
△	157.500				.000
△	180.000				

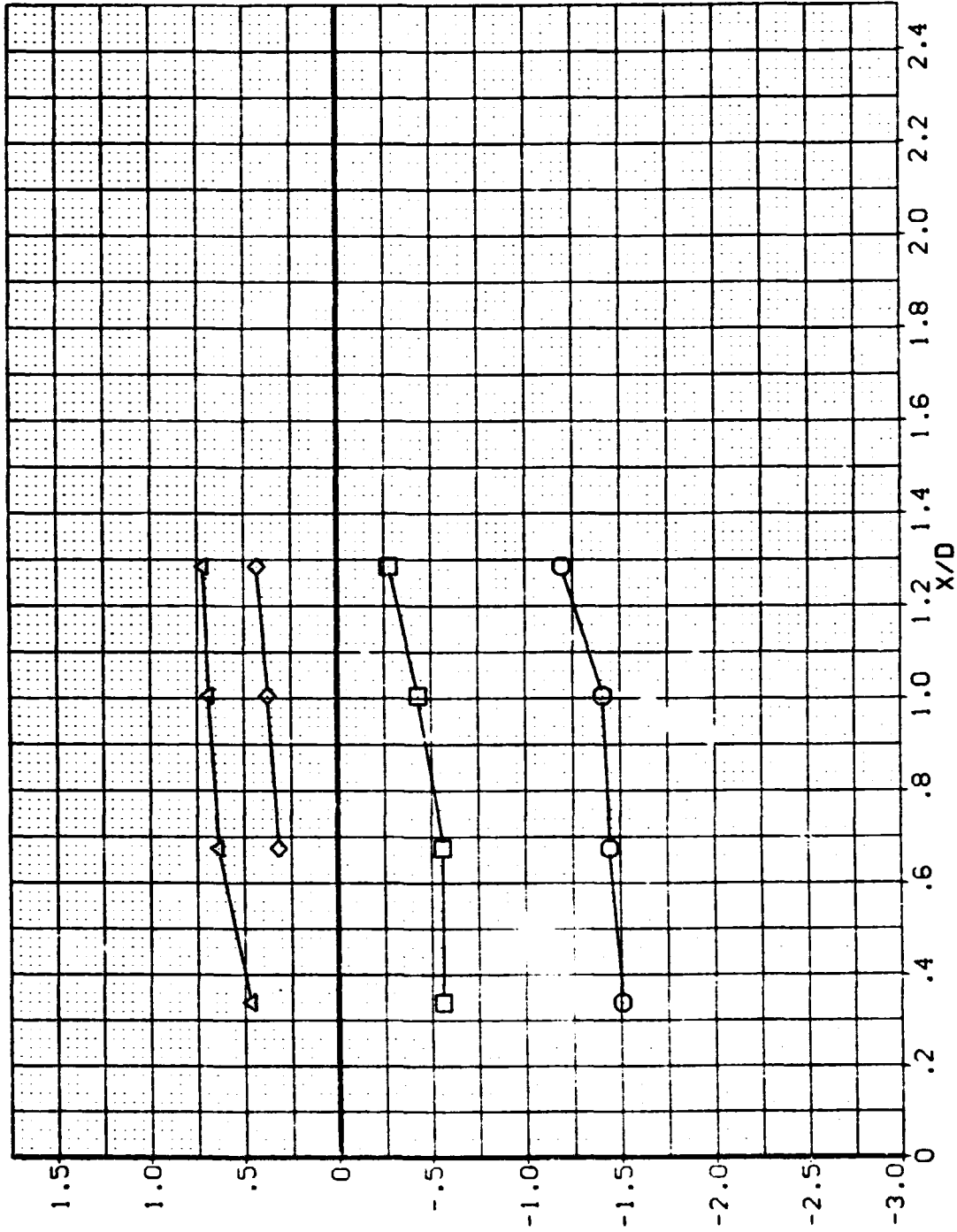

PRESSURE COEFFICIENT ALONG THE BODY AT VARIOUS POSITIONS AROUND THE BODY

MSFC HRWT G33 (S.29F) SRB FORWARD NOSE SECTION (D1E102)

PARAMETRIC VALUES
 .000 PHI .000
 BETA 18.100
 RN

ALPHA MACH
 .000 .790
 22.500
 45.000
 67.500
 90.000

SYMBOL
 □ ◇ △ ▽

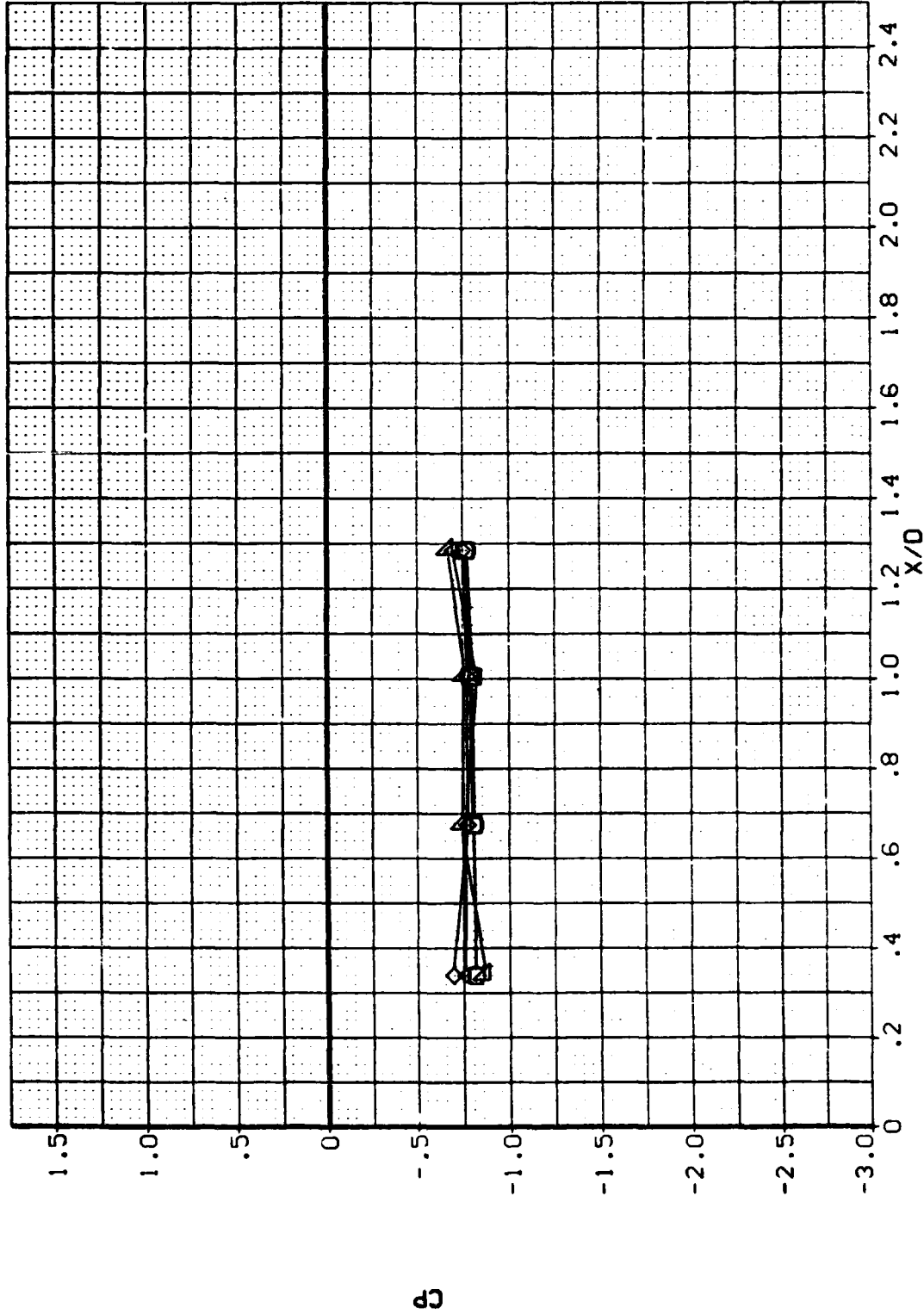

PRESSURE COEFFICIENT ALONG THE BODY AT VARIOUS POSITIONS AROUND THE BODY

MSFC HRWT 033 (SA29F) SRB FORWARD NOSE SECTION (D1E102)

SYMBOL	THETA	ALPHA	MACH	BETA	PHI
○	112,500	100,000	.790	RN	.000
□	135,000			18.100	
◇	157,500				
△	180,000				

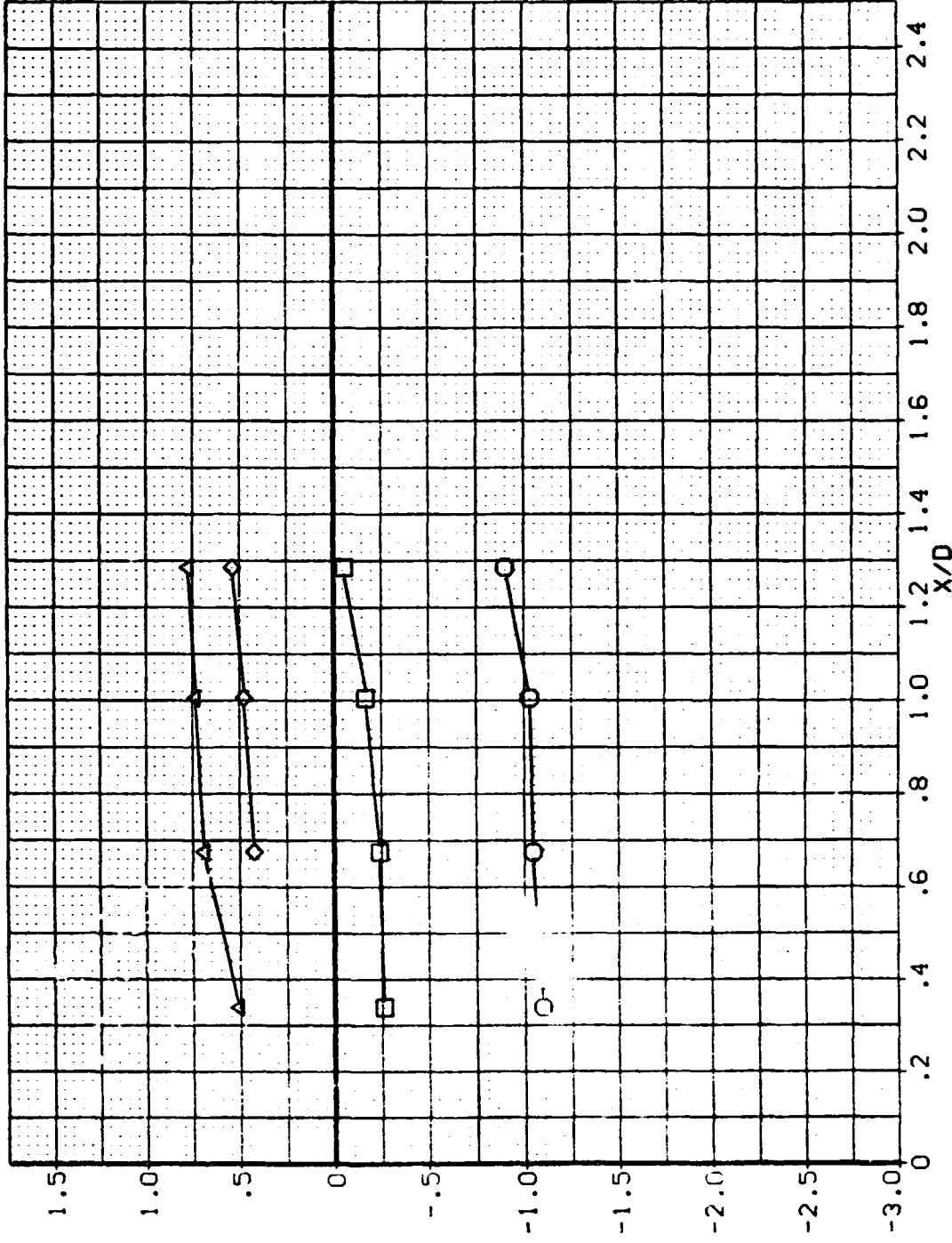

43

PRESSURE COEFFICIENT ALONG THE BODY AT VARIOUS POSITIONS AROUND THE BODY

MSFC HRWT 033 (SA29F) SRB FORWARD NOSE SECTION (E1E103)

SYMBOL	THETA	ALPHA	MACH	BETA	PARAMETRIC VALUES
□	.000	100.000	2.000	RN	.000 PHI
◇	22.500				9.000
◇	45.000				
◇	67.500				
◇	90.000				

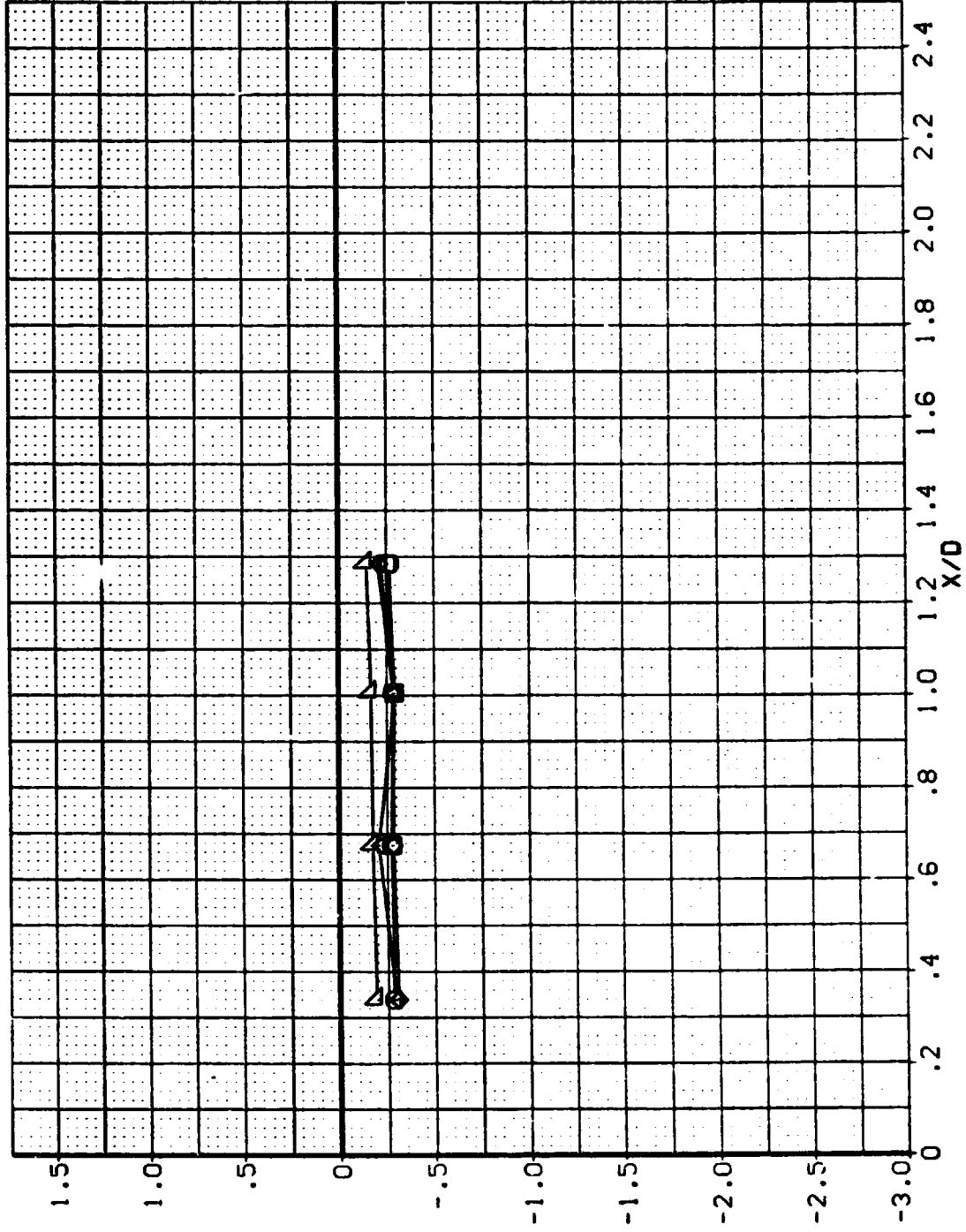

PRESSURE COEFFICIENT ALONG THE BODY AT VARIOUS POSITIONS AROUND THE BODY

MSFC HRWT 033 (SA29F) SRB FORWARD NOSE SECTION (E1E103)

SYMBOL	THETA	ALPHA	MACH	BETA	PARAMETRIC VALUES
○	112.500	100.000	2.000	RN	.000 PM1
□	135.000				9.000
◇	157.500				.000
△	180.000				

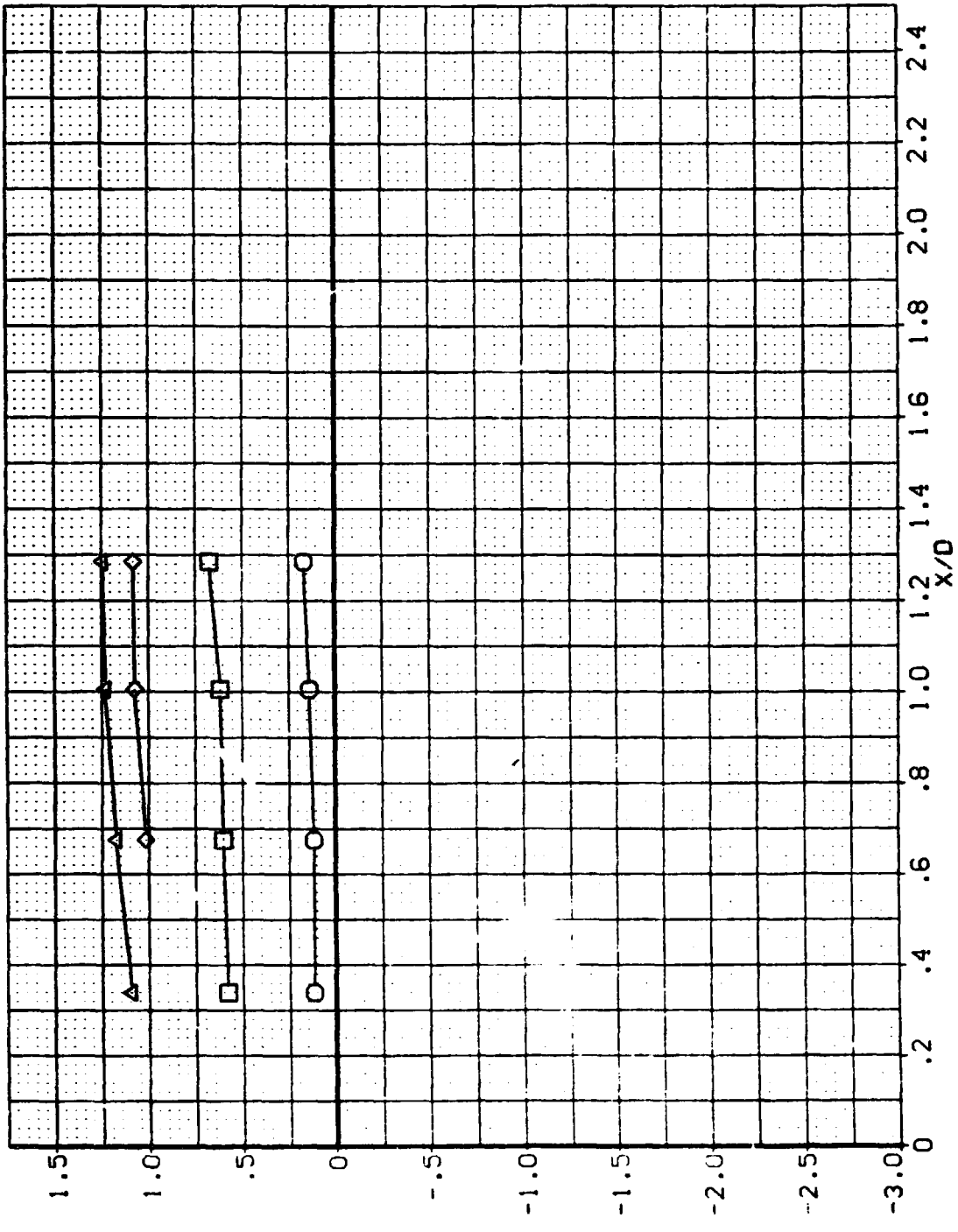

PRESSURE COEFFICIENT ALONG THE BODY AT VARIOUS POSITIONS AROUND THE BODY

MSFC HEAT 033 (SM29F) SRB FORWARD NOSE SECTION (E1E101)

THETA	ALPHA	MACH	PARAMETRIC VALUES
.000	107.900	.410	000 PHI
22.500			18.100
45.000			
67.500			
90.000			

SYMBOL
 □
 ○
 ◇
 △

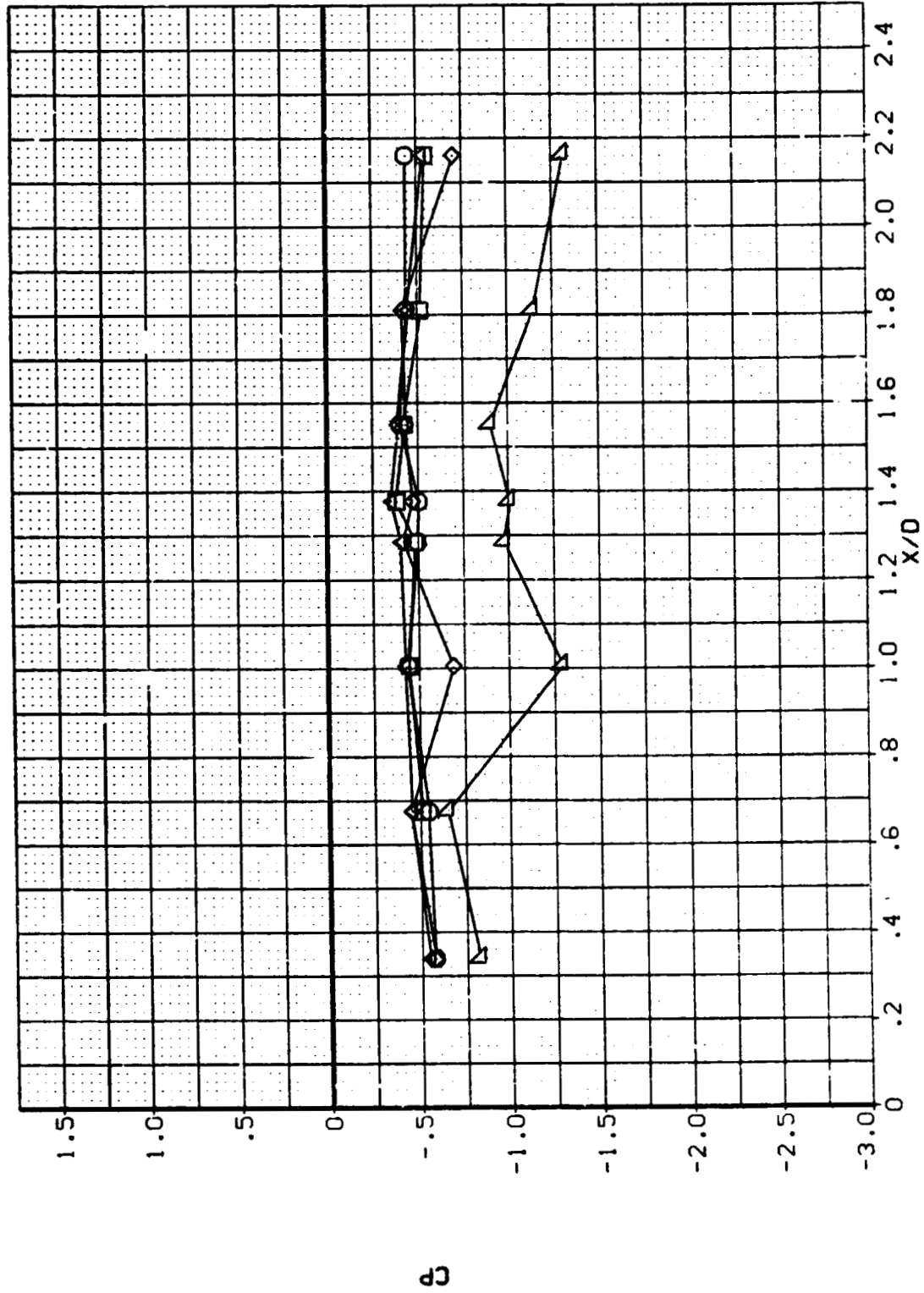

PRESSURE COEFFICIENT ALONG THE BODY AT VARIOUS POSITIONS AROUND THE BODY

MSFC HRWT U-3 (SA29F) SRB FORWARD NOSE SECTION (E1E101)

SYMBOL	THETA	ALPHA	MACH	BETA	PARAMETRIC VALUES
○	112.500	107.900	.410	RN	.000 PHI
□	135.000				18.100
◇	157.500				
△	180.000				

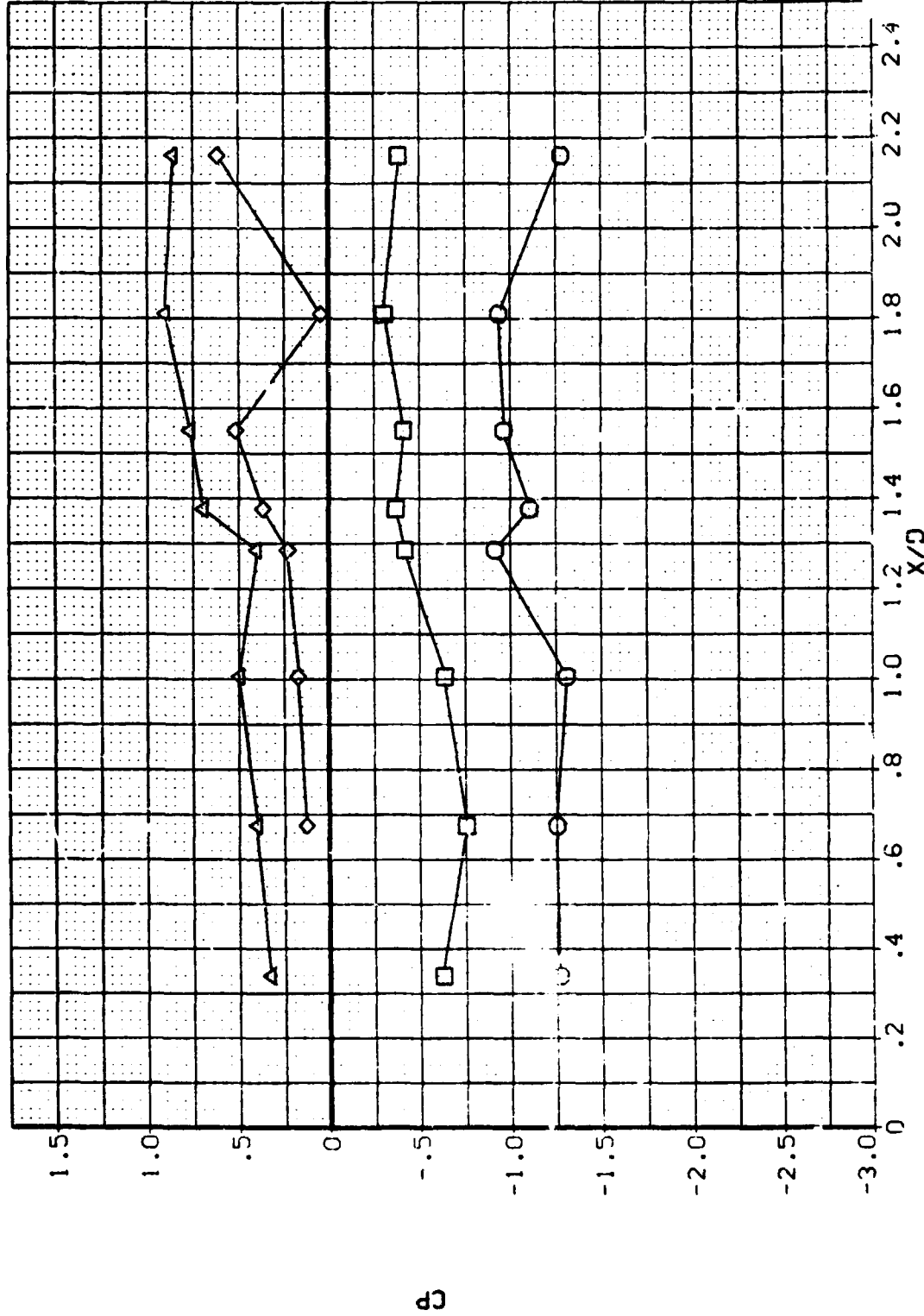

PRESSURE COEFFICIENT ALONG THE BODY AT VARIOUS POSITIONS AROUND THE BODY

MSFC HRWT U33 (SA29F) SRB FORWARD NOSE SECTION (E1E1C2)

SYMBOL	THETA	ALPHA	MACH	BETA	PHI
□	.000	108.000	.500	RN	.000
◇	22.500				
○	45.000				
△	67.500				
▽	90.000				

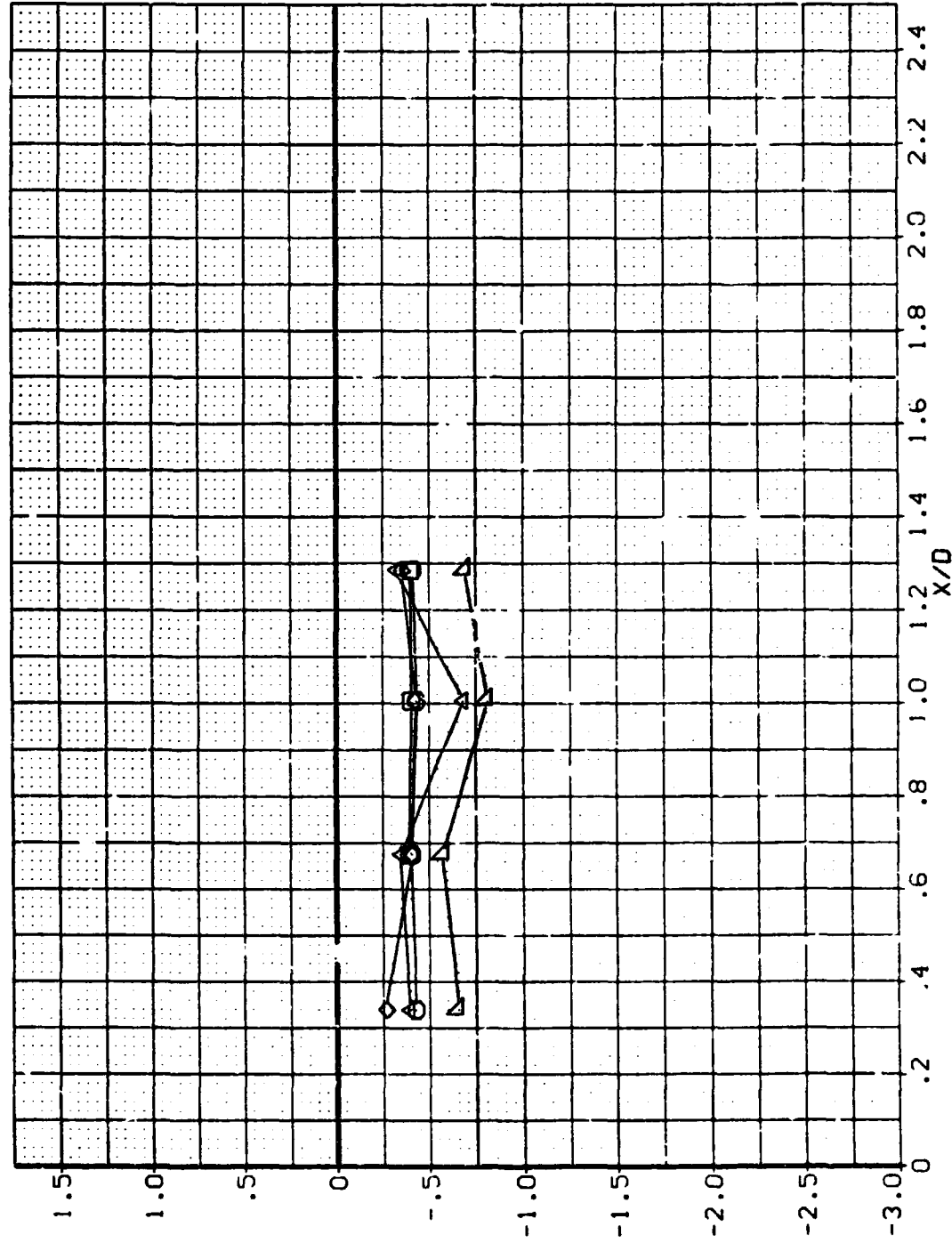

PRESSURE COEFFICIENT ALONG THE BODY AT VARIOUS POSITIONS AROUND THE BODY

MSFC HRWT 033 (SA29F) SRB FORWARD NOSE SECTION (E1E102)

SYMBOL	THETA	ALPHA	MACH	BETA	PARAMETRIC VALUES
○	112.500	108.000	.500	RN	.000 PHI
□	135.000				18.100
◇	157.500				
△	180.000				

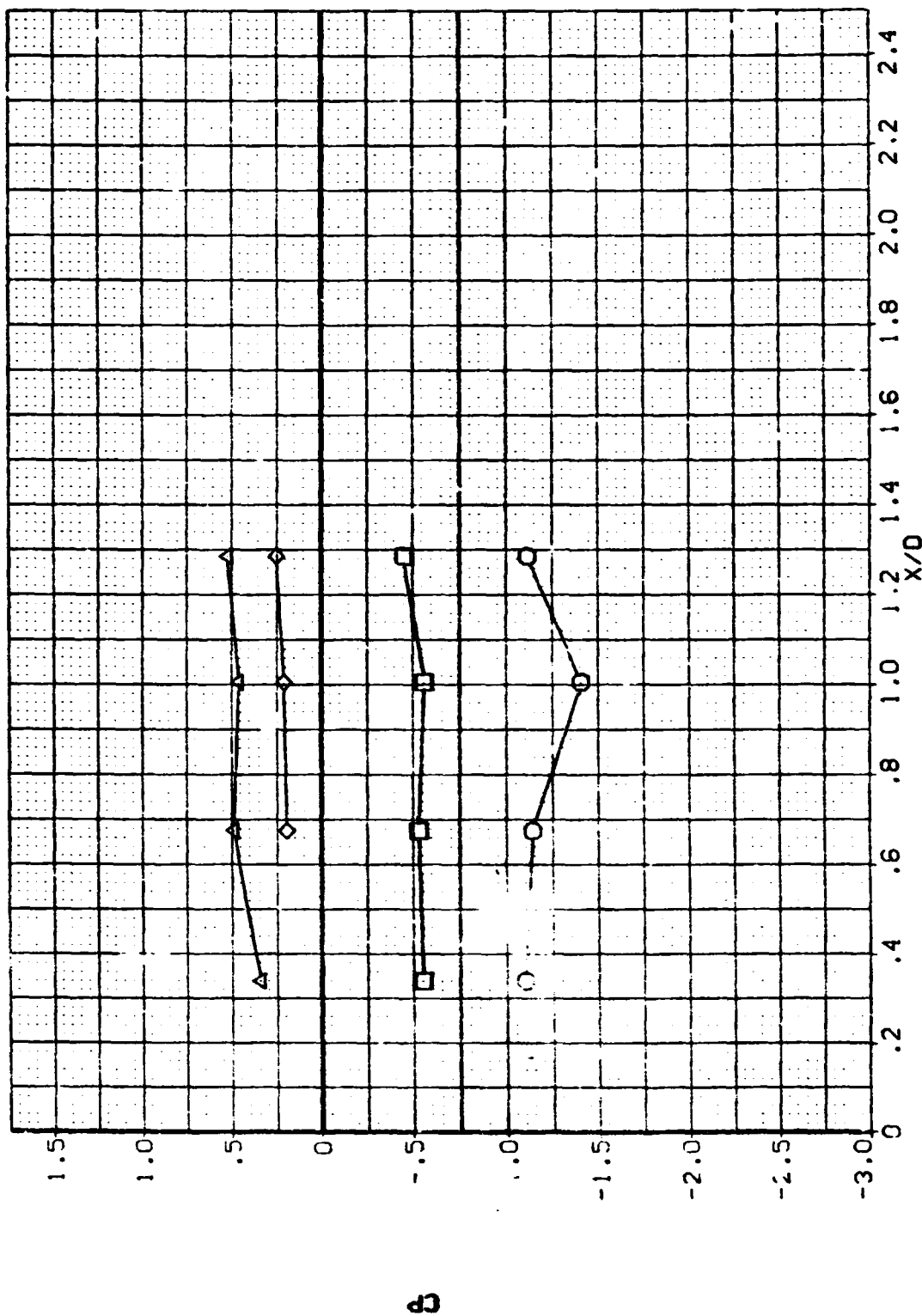

PRESSURE COEFFICIENT ALONG THE BODY AT VARIOUS POSITIONS AROUND THE BODY

MSFC HWRT 033 (5A29F) SRB FORWARD NOSE SECTION (F1E101)

PARAMETRIC VALUES
 .000 PHI .000
 19.100 RN

ALP . MACH
 107.900 .610

THETA
 .000
 22.500
 45.000
 67.500
 90.000

SYMBOL
 □ ◇ ▲

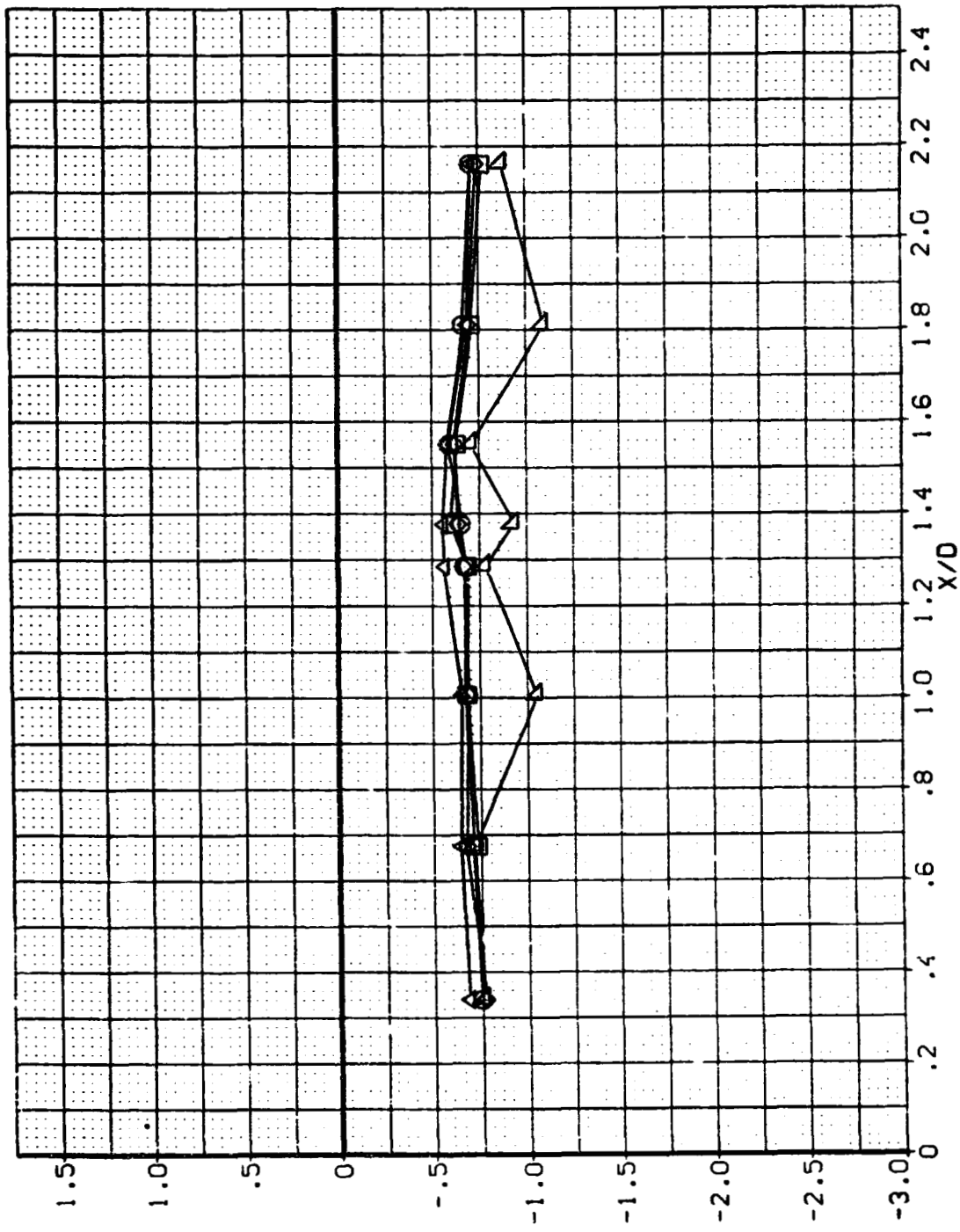

PRESSURE COEFFICIENT ALONG THE BODY AT VARIOUS POSITIONS AROUND THE BODY

MSFC HRWT 033 (SA29F) SRB FORWARD NOSE SECTION (F1E101)

SYMBOL	THETA	ALPHA	MACH	BETA	PHI
○	112.500	107.900	.610	RN	.000
□	135.000			RN	18.100
◇	157.500				
△	180.000				

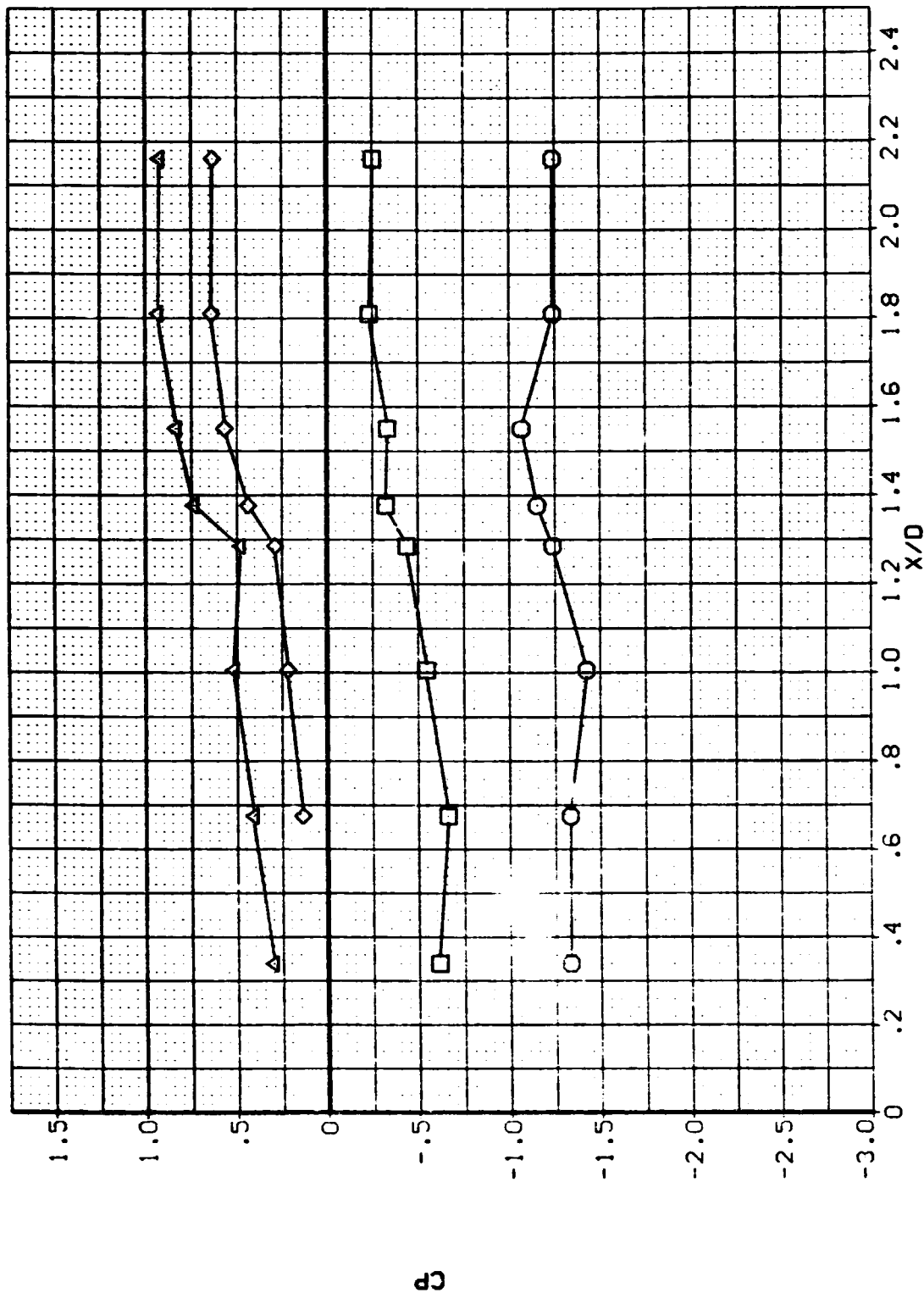

PRESSURE COEFFICIENT ALONG THE BODY AT VARIOUS POSITIONS AROUND THE BODY

MSFC HRWT 03 (SA29F) SRB FORWARD NOSE SECTION (FIE101)

SYMBOL	THETA	ALPHA	MACH	BETA	PHI
	.000	107.900	.760	RN	.000
□	22.500			18.100	
◇	45.000				
△	67.500				
▽	90.000				

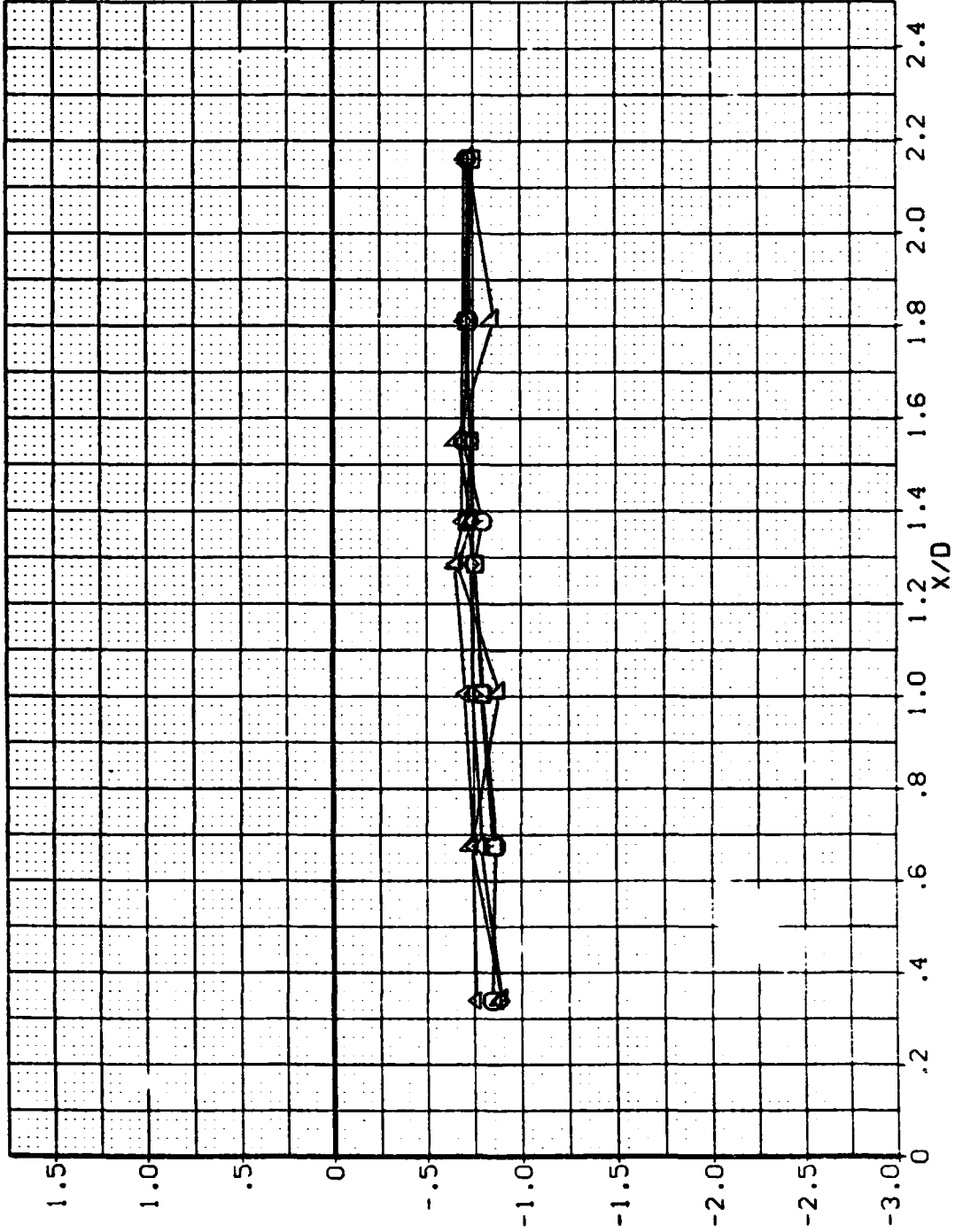

63

PRESSURE COEFFICIENT ALONG THE BODY AT VARIOUS POSITIONS AROUND THE BODY

MSFC HRWT 033 (SA29F) SRB FORWARD NOSE SECTION (F1E101)

SYMBOL	THETA	ALPHA	MACH	BETA	PHI
○	112.500	107.900	.760	RN	.000
□	135.000				
◇	157.500				
△	180.000				

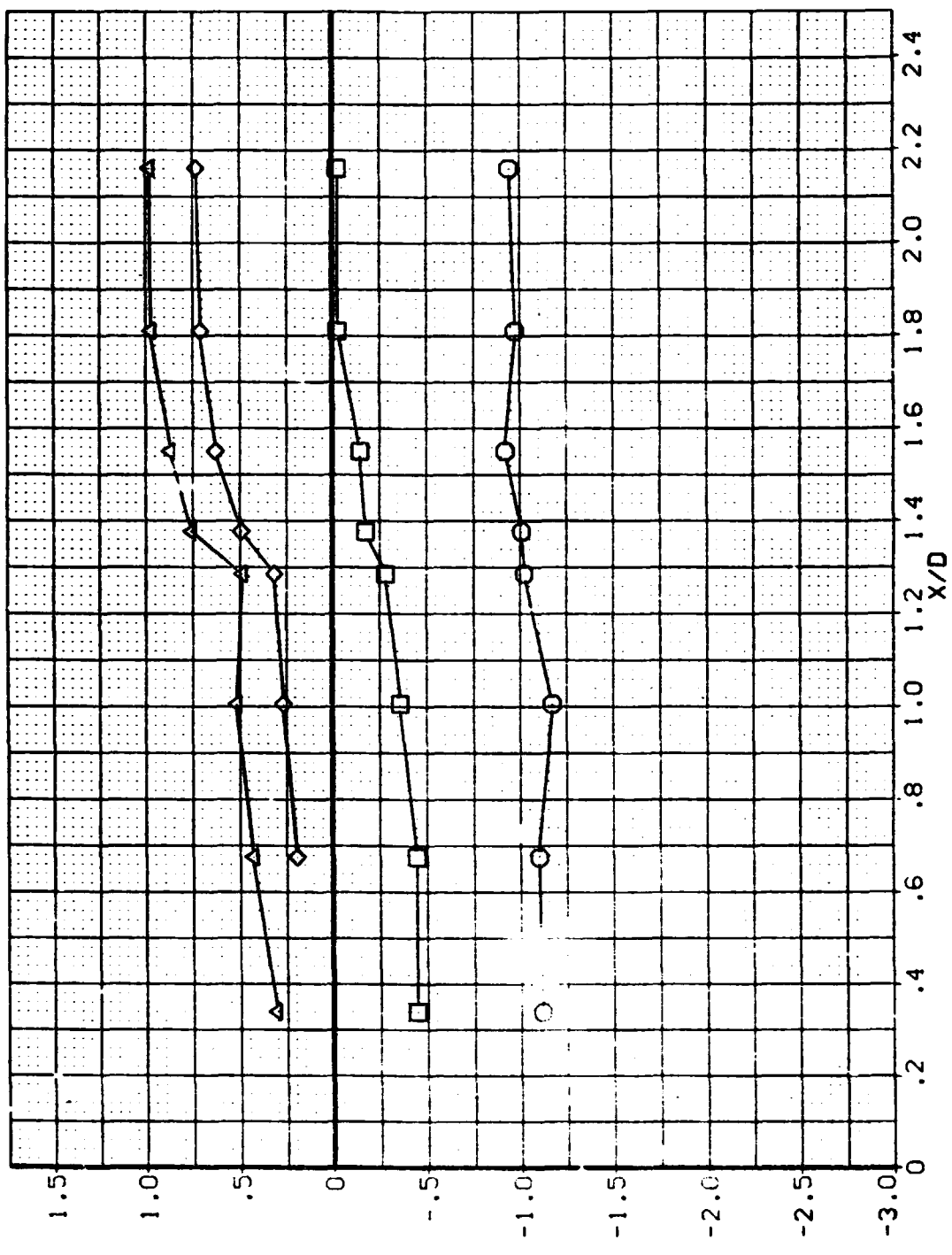

83

PRESSURE COEFFICIENT ALONG THE BODY AT VARIOUS POSITIONS AROUND THE BODY

MSFC HRV J33 (29F) SRB FORWARD NOSE SECTION (F1E103)

SYMBOL
 □ ◇ ◊ ◻

THETA .000 ALPHA 108.000 MACH 2.000
 22.500
 45.000
 67.500
 90.000

BETA RN
 .000 9.000
 PHI .000

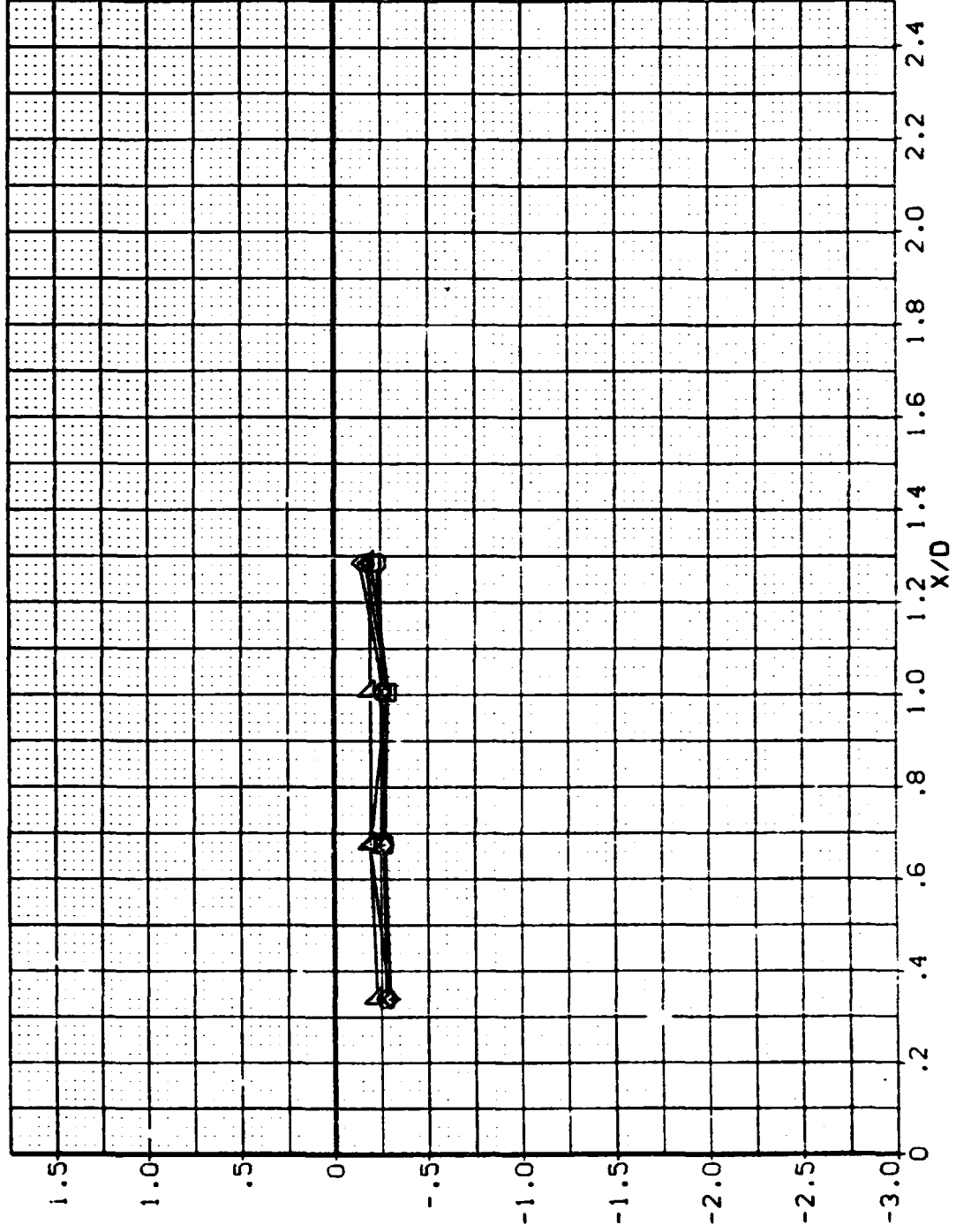

8

PRESSURE COEFFICIENT ALONG THE BODY AT VARIOUS POSITIONS AROUND THE BODY

MSFC HRWT 033 (SA29F) SRB FORWARD NOSE SECTION (F1E103)

SYMBOL	THETA	ALPHA	MACH	BETA	PARAMETRIC VALUES
○	112.500	108.000	2.000	RN	.000 PHI
□	135.000				8.000
◇	157.500				
△	180.000				

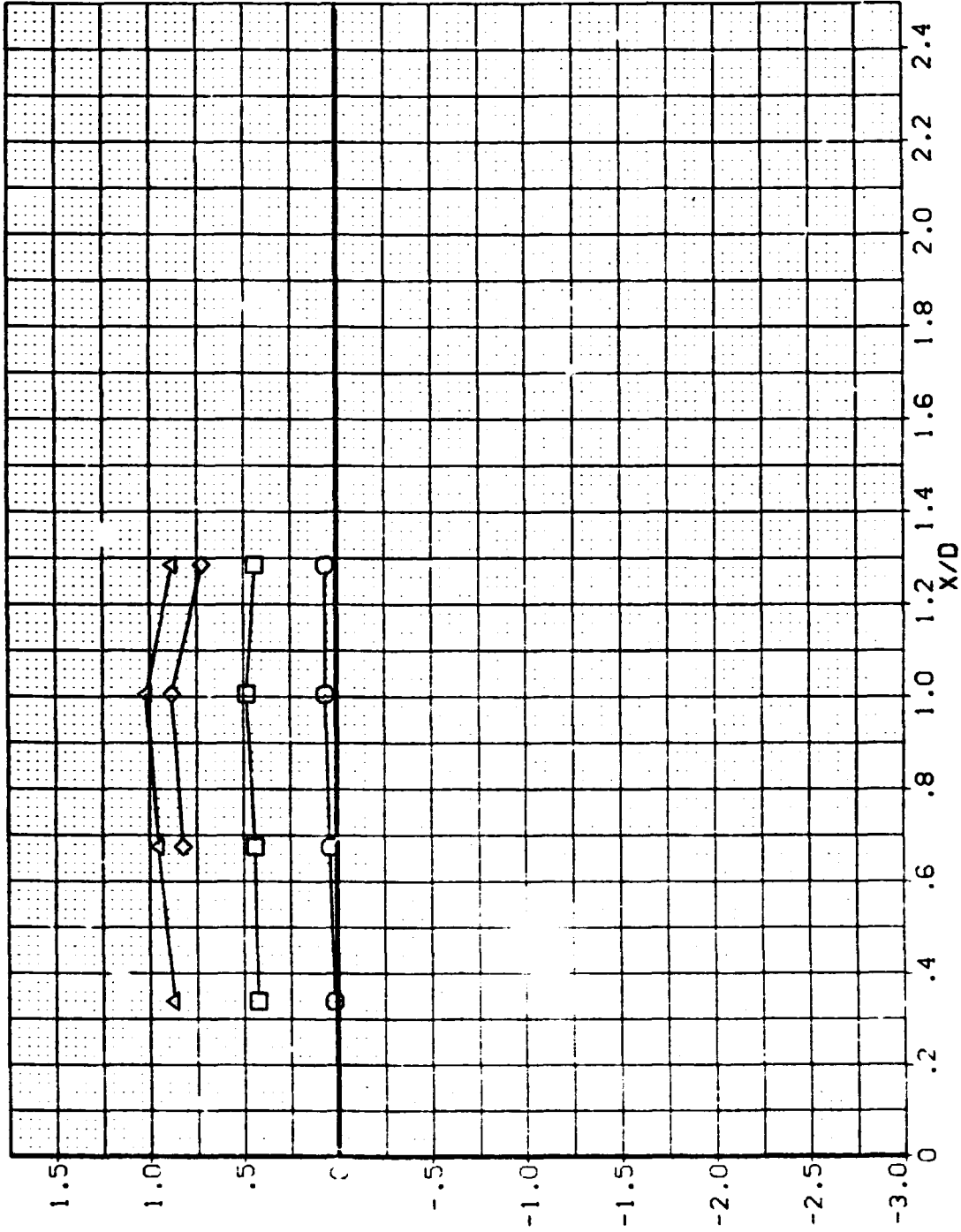

93

PRESSURE COEFFICIENT ALONG THE BODY AT VARIOUS POSITIONS AROUND THE BODY

MSFC HRWT 033 (S₀29F) SRB FORWARD NOSE SECTION (A1E101)

SYMBOL	X/D	ALPHA	MACH	BETA	PHI
	.340	72.100	.410	RN	.000
○	.675				18.100
□	1.007				
◇	1.265				

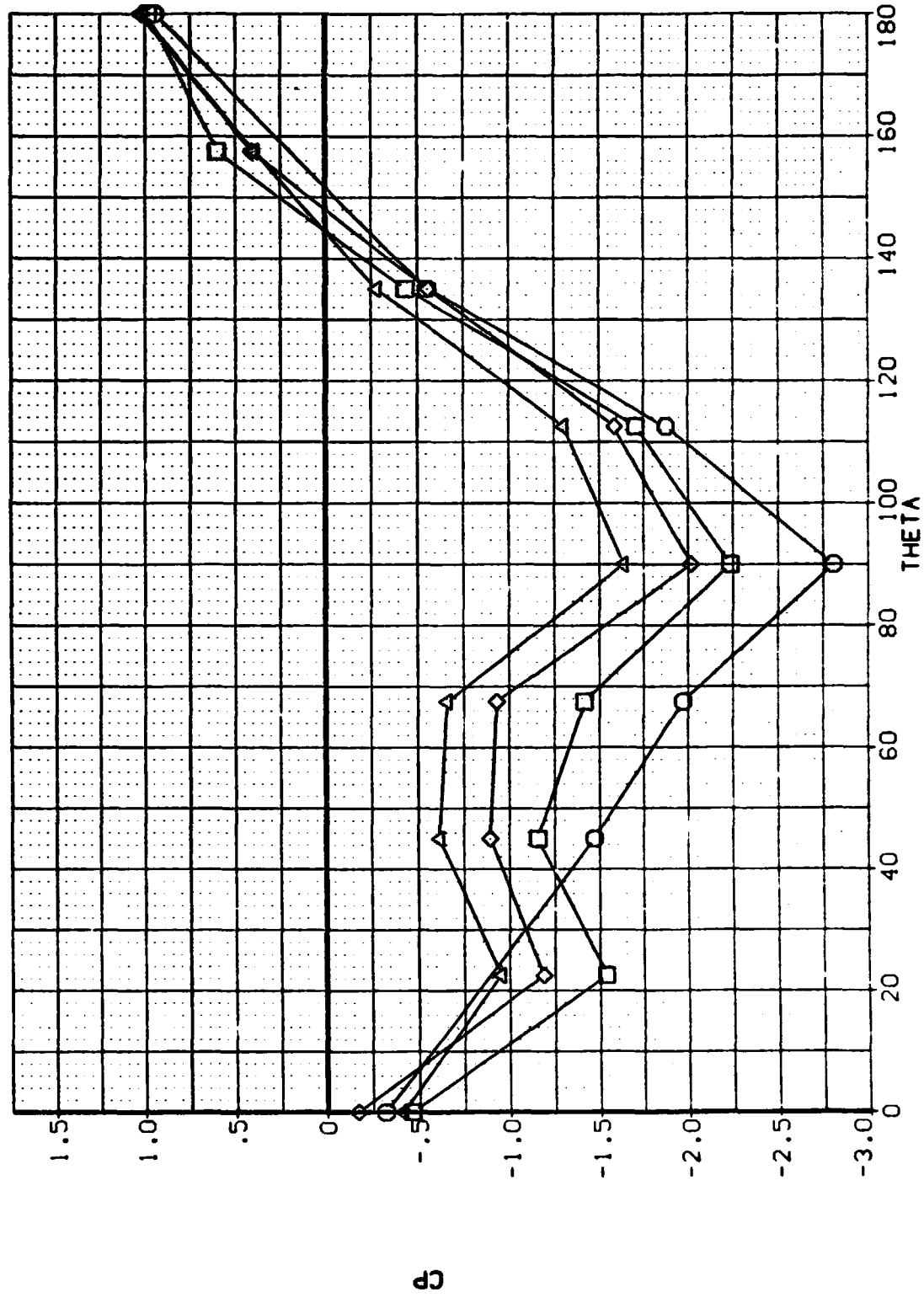

PRESSURE COEFFICIENT AROUND THE BODY AT VARIOUS STATIONS ALONG THE BODY

MSFC HRWT 033 (SA29F) SRB FORWARD NOSE SECTION (A1E101)

SYMBOL	X/D	ALPHA	MACH	BETA	PHI
○	1.377	72.100	.410	RN	.000
□	1.550				
◇	1.810				
△	2.160				

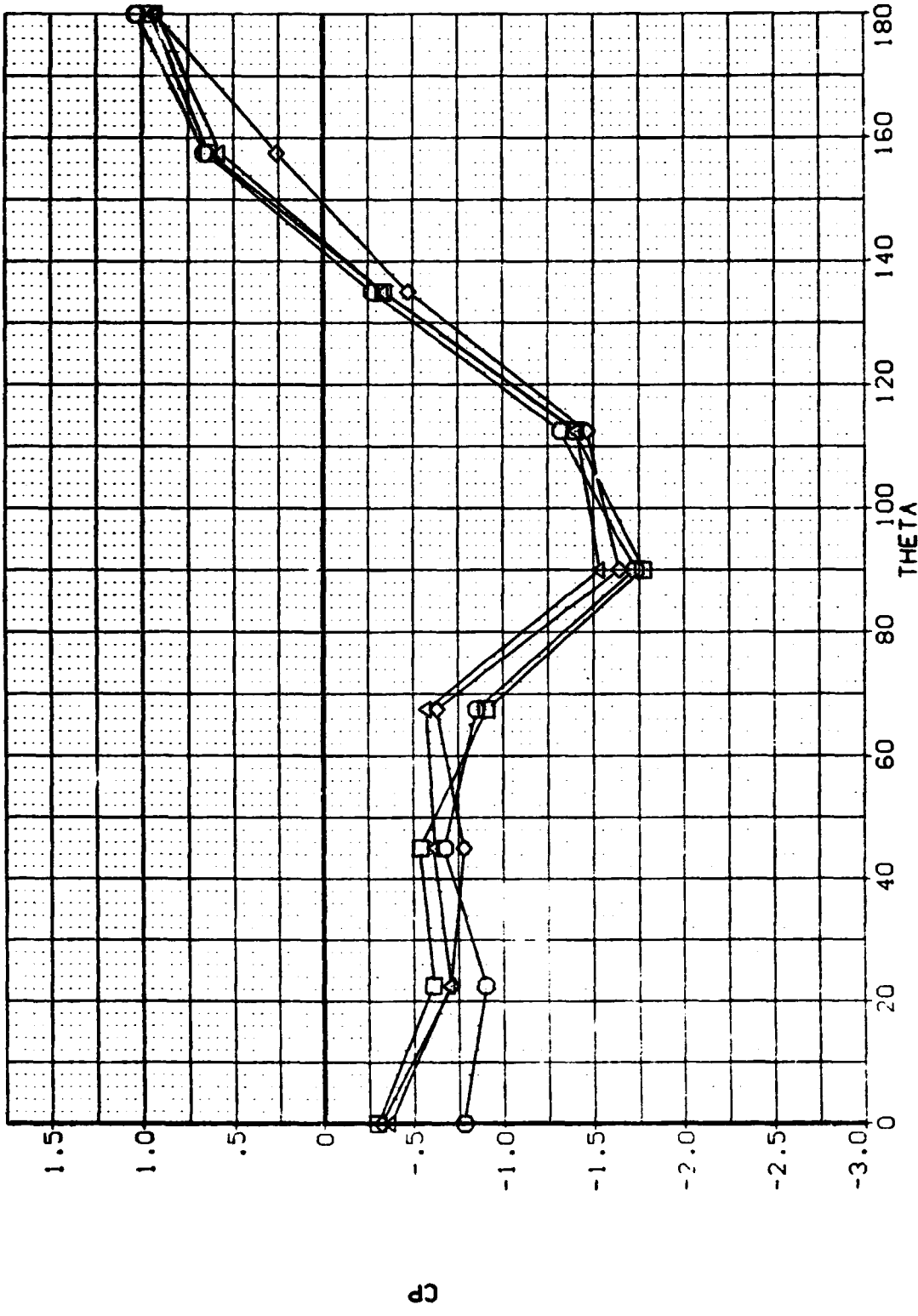

PRESSURE COEFFICIENT AROUND THE BODY AT VARIOUS STATIONS ALONG THE BODY

MSFC HWPT 033 (SA29F) SRB FORWARD NOSE SECTION (A1E102)

SYMBOL	○	□	◇	△	PARAMETRIC VALUES	
	X/D	ALPHA	MACH	BETA		PHI
	.340	72.000	.500	RN		.000
	.675			18.100		.000
	1.007					
	1.285					

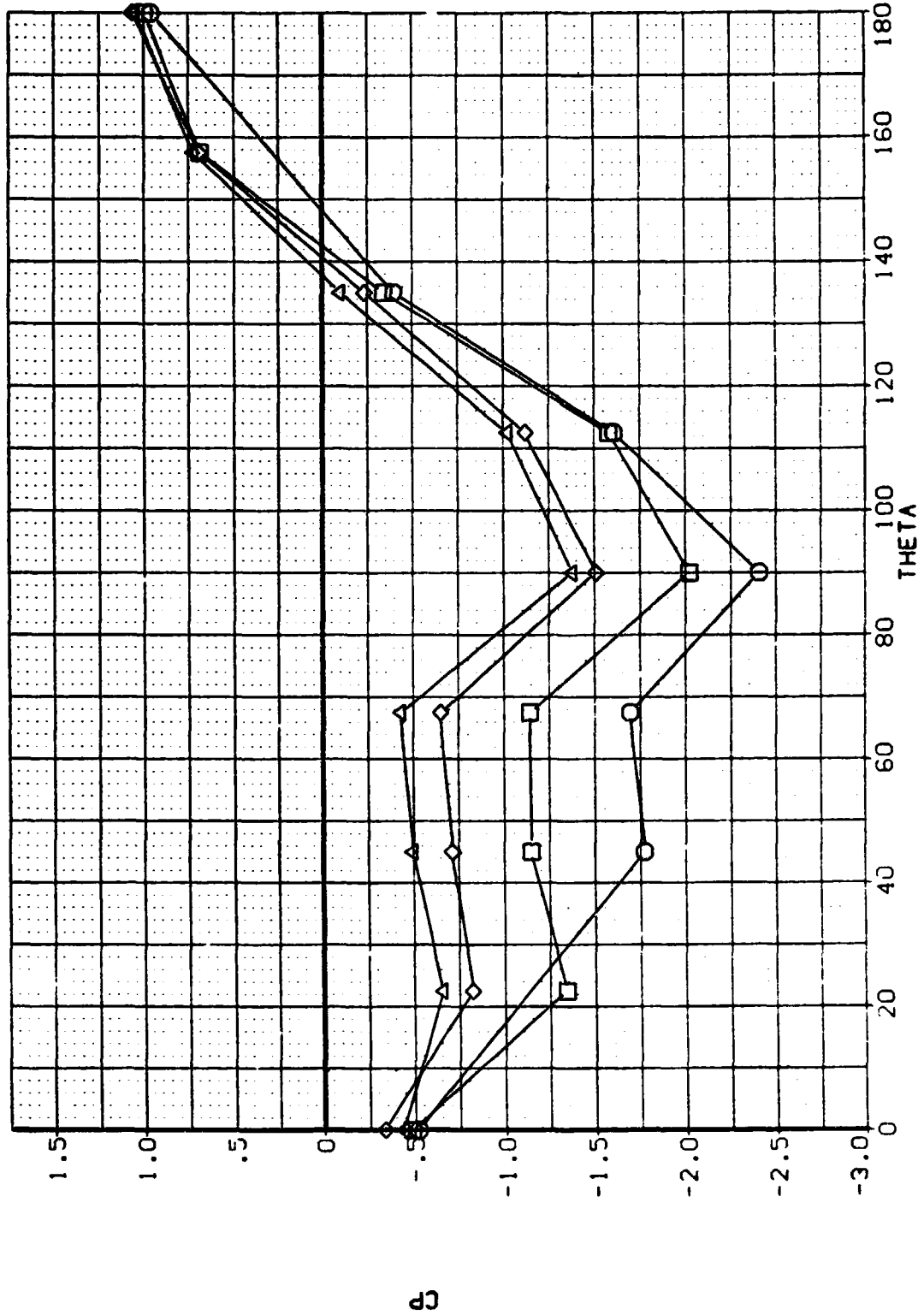

PRESSURE COEFFICIENT AROUND THE BODY AT VARIOUS STATIONS ALONG THE BODY

MSFC HRWT 033 (SA29F) SRB FORWARD NOSE SECTION (B1E101)

SYMBOL	X/D	ALPHA	MACH	BETA	PHI
○	.340	72.100	.600	RN	.000
□	.675				18.100
◇	1.007				
△	1.285				

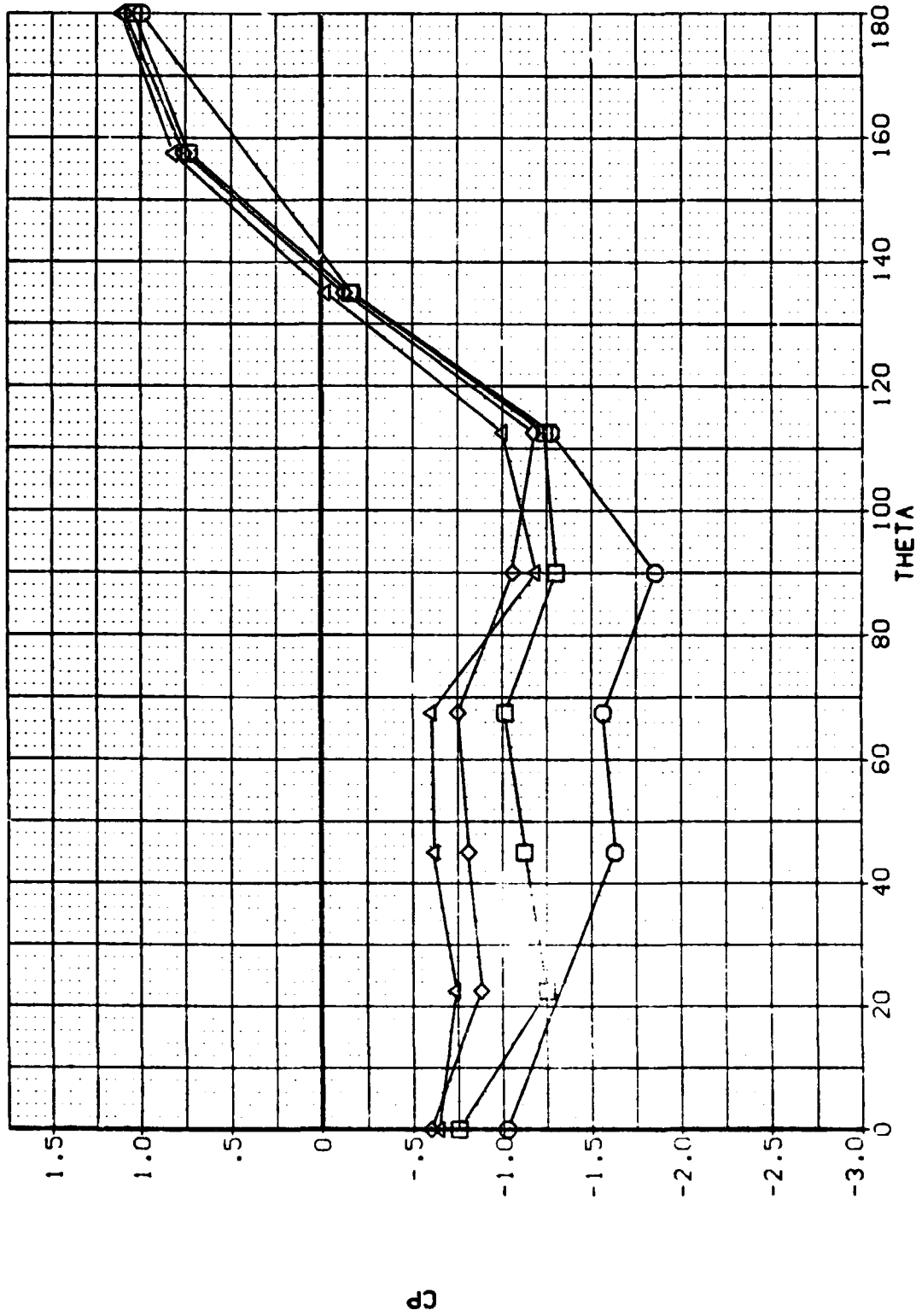

PRESSURE COEFFICIENT AROUND THE BODY AT VARIOUS STATIONS ALONG THE BODY

MSFC HRW 033 (CA29F) SRB FORWARD NOSE SECTION (B1E101)

SYMBOL	X/C	ALPHA	MACH	BETA	PHI
○	1.377	72.100	.600	RN	18.100
□	1.550				.000
◇	1.810				
△	2.160				

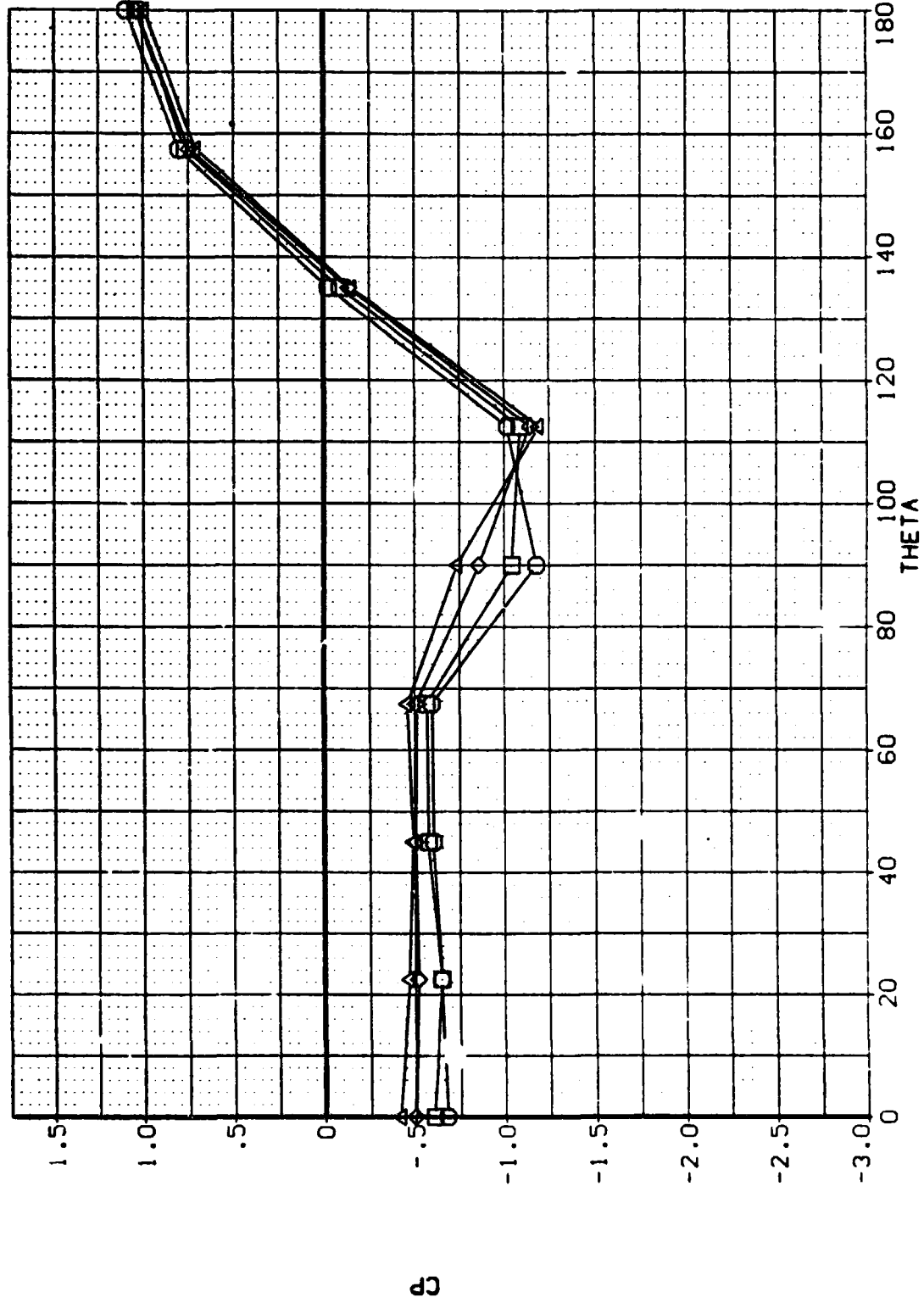

PRESSURE COEFFICIENT AROUND THE BODY AT VARIOUS STATIONS ALONG THE BODY

MSFC HRWT 033 (SA29F) SRB FORWARD NOSE SECTION (B1E101)

SYMBOL	X/D	ALPHA	MACH	BETA	PHI
○	.340	72.100	.760	RN	.000
□	.675			RN	18.100
◇	1.007				
△	1.285				

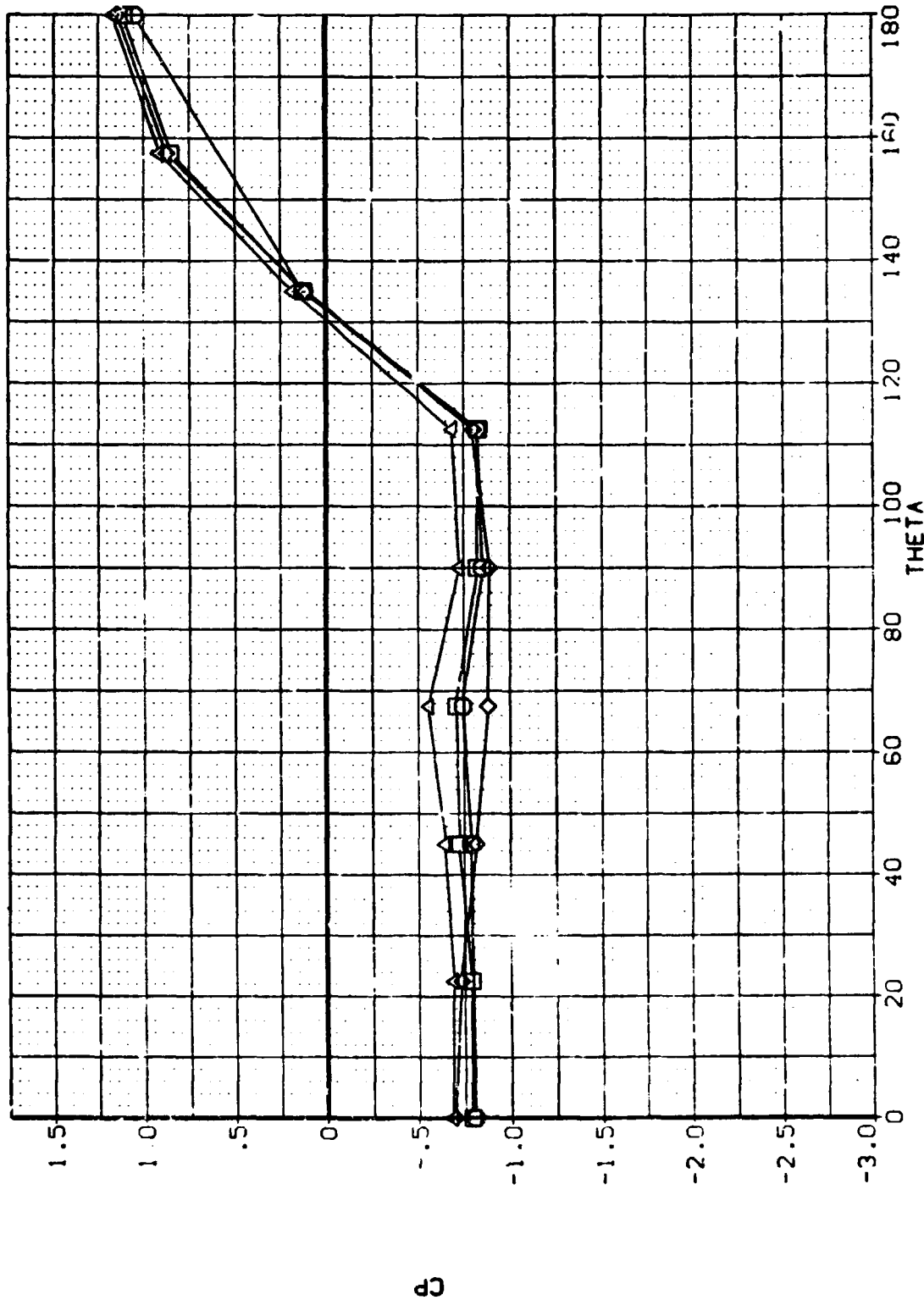

PRESSURE COEFFICIENT AROUND THE BODY AT VARIOUS STATIONS ALONG THE BODY

MSFC HWRT 033 (SA29F) SRB FORWARD NOSE SECTION (B1E101)

SYMBOL	X/D	ALPHA	MACH	BETA	PHI
○	1.377	72.100	.760	RN	18.100
□	1.590				
◇	1.810				
△	2.160				

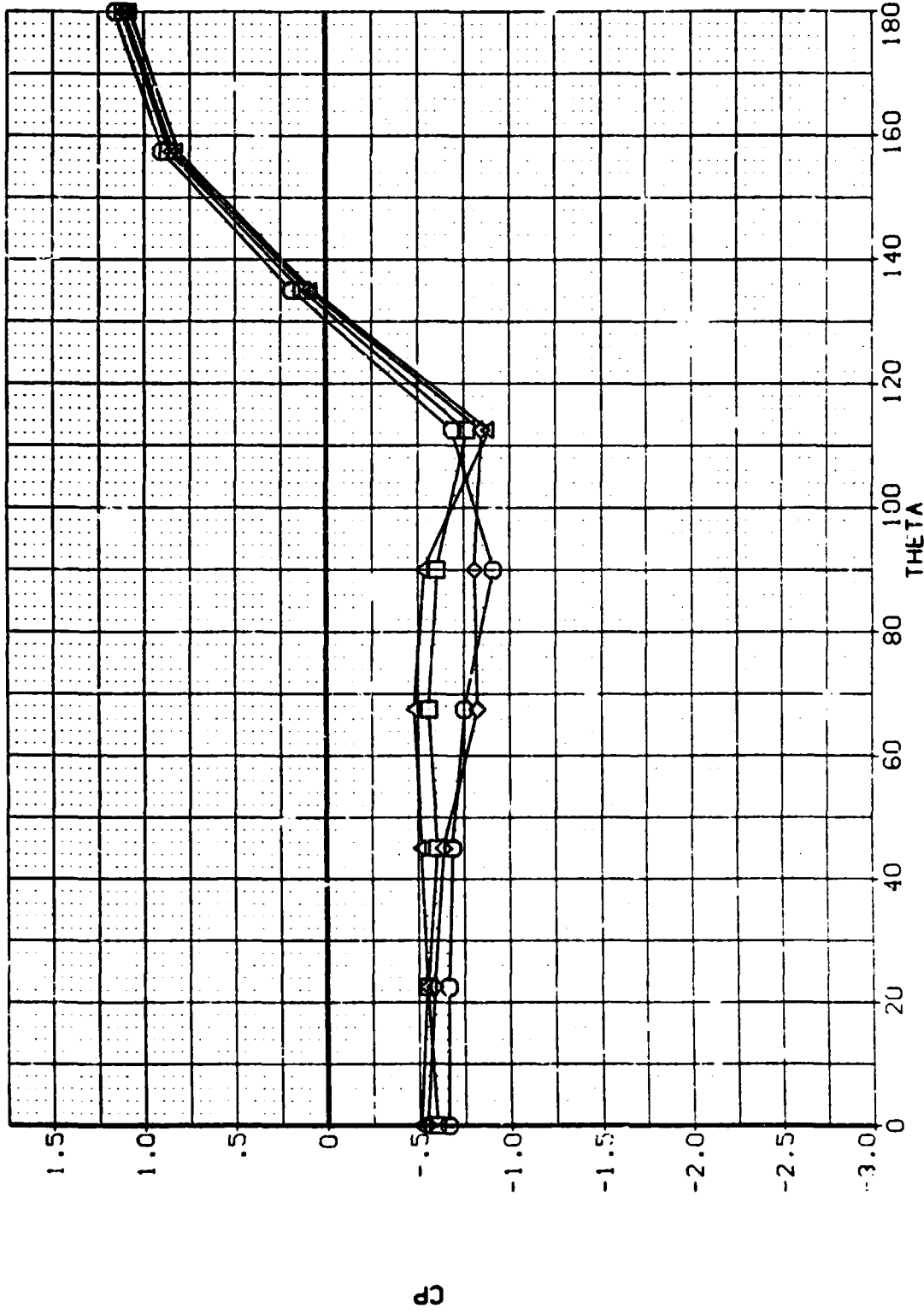

PRESSURE COEFFICIENT AROUND THE BODY AT VARIOUS STATIONS ALONG THE BODY

MSFC HRWT 033 (SA29F) SRB FORWARD NOSE SECTION (81E103)

SYMBOL	X/D	ALPHA	MACH	BETA	PHI
○	.340	72.000	2.000	9.000	.000
□	.675				
◇	1.007				
△	1.285				

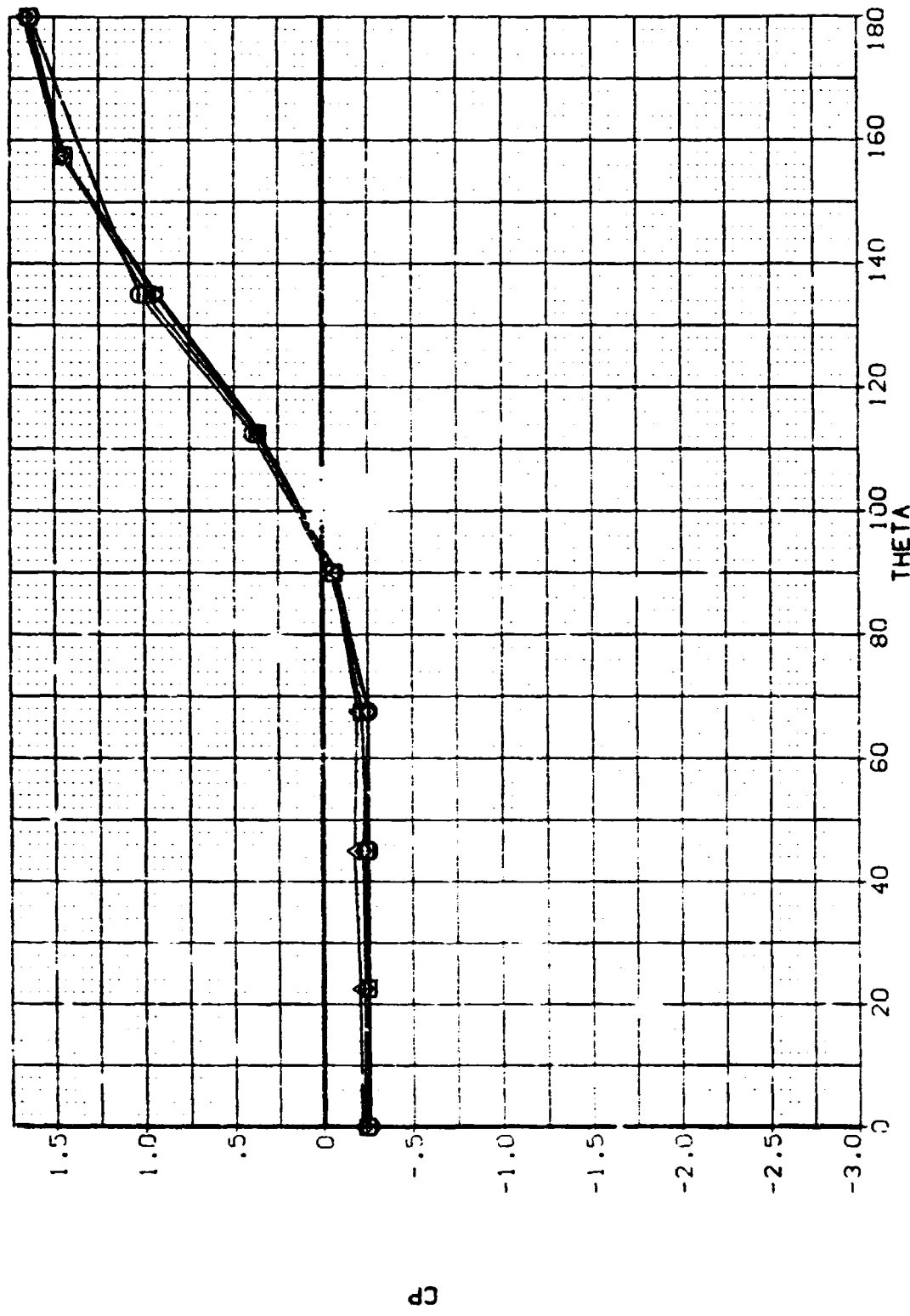

PRESSURE COEFFICIENT AROUND THE BODY AT VARIOUS STATIONS ALONG THE BODY

MSFC HRWI 033 (SA29F) SRB FORWARD NOSE SECTION (B1E102)

PARAMETRIC VALUES
 .000 PHI .000
 18.100 BETA
 RN

ALPHA MACH
 80.000 .510

X/D
 .340
 .675
 1.07
 1.285

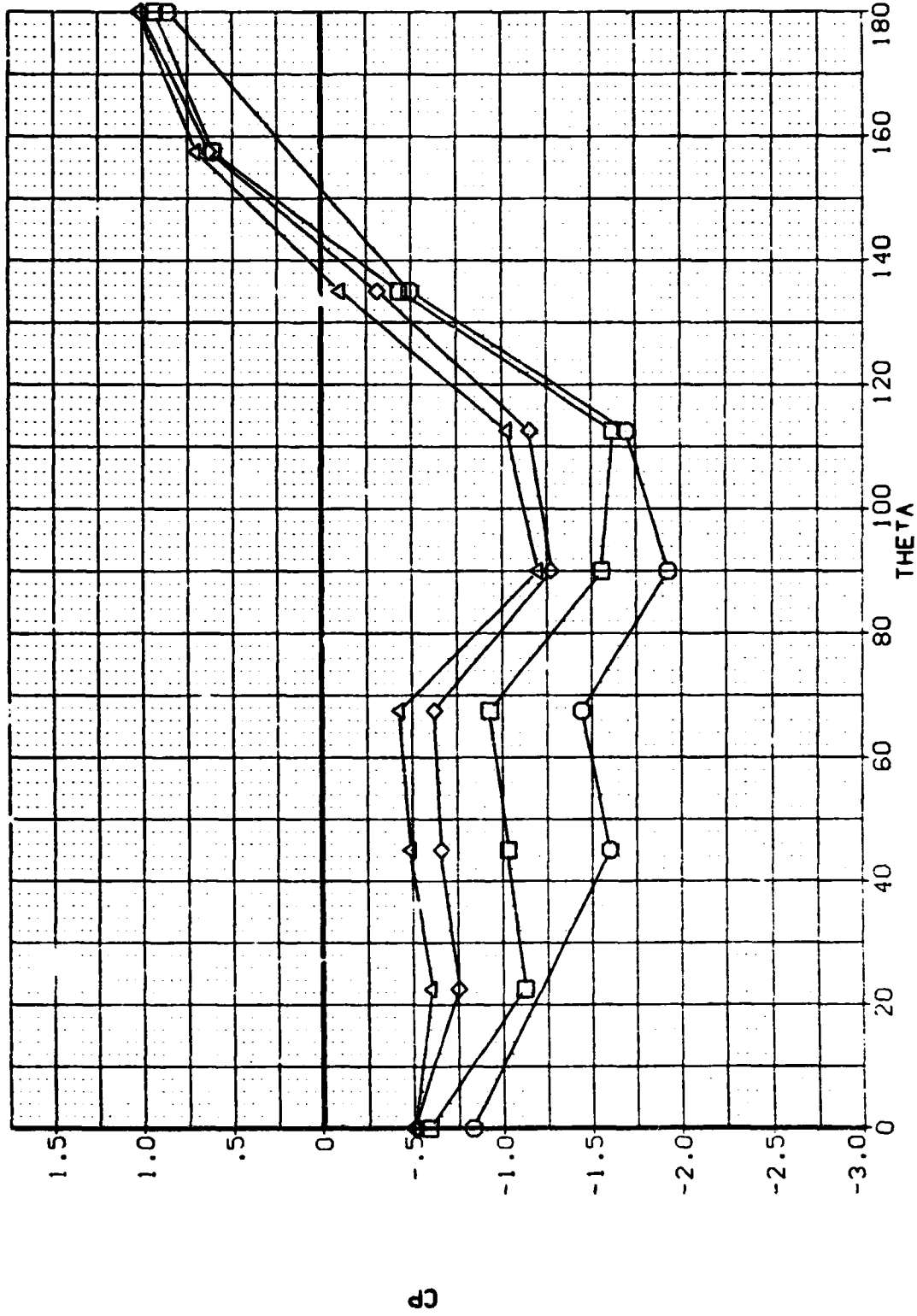

PRESSURE COEFFICIENT AROUND THE BODY AT VARIOUS STATIONS ALONG THE BODY

MSFC HRWT 033 (SA295) FORWARD NOSE SECTION (B1E102)

SYMBOL	X/D	ALPHA	MACH	BETA	PHI
○	.340	80.000	.600	18.100	.000
□	.675				
◇	1.007				
△	1.285				

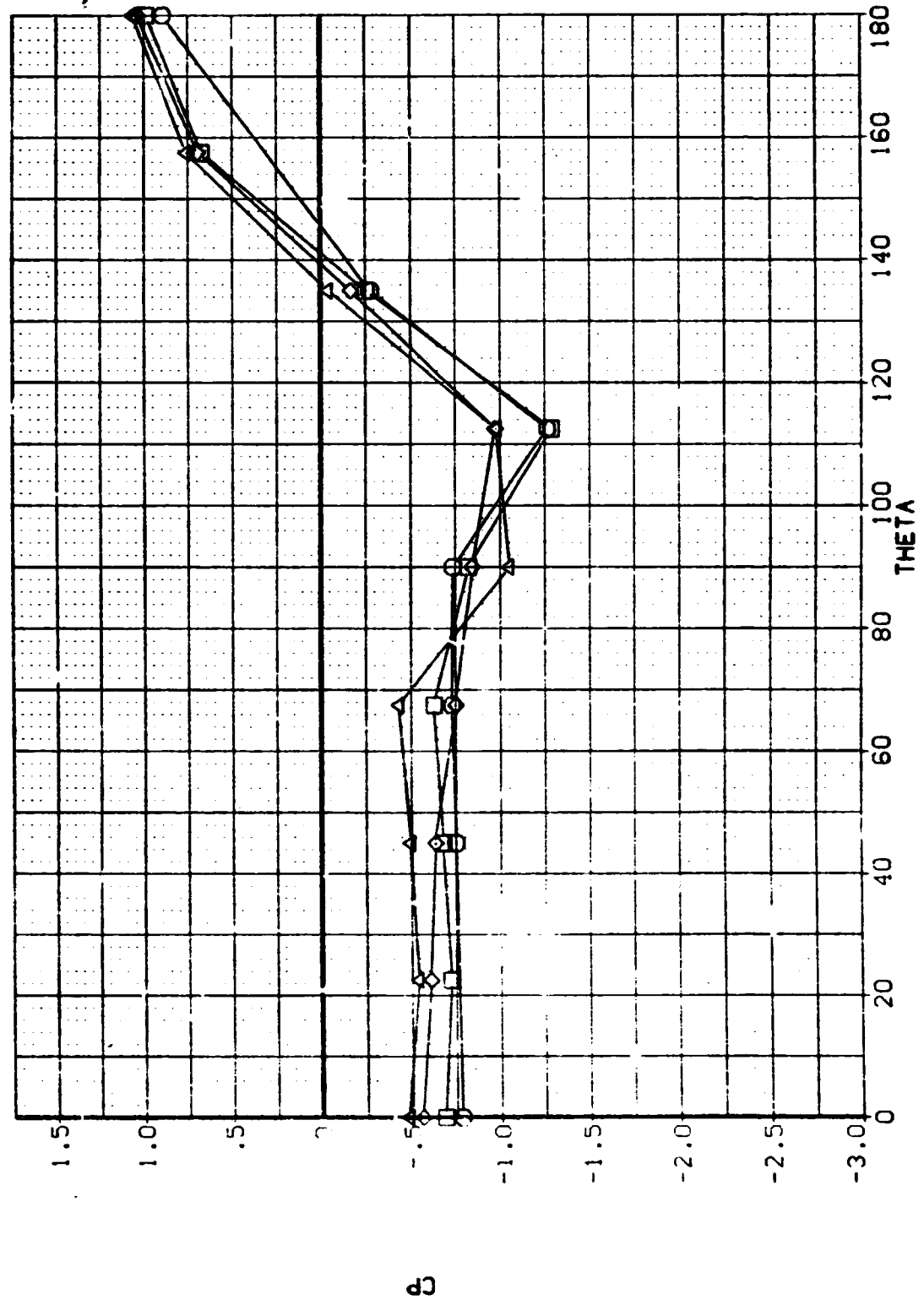

PRESSURE COEFFICIENT AROUND THE BODY AT VARIOUS STATIONS ALONG THE BODY

MSFC HRWT 033 (SA29F) SRB FORWARD NOSE SECTION (B1E102)

SYMBOL	X/D	ALPHA		BETA		PARAMETRIC VALUES	
		80.000	F/ACH	RN	PHI	.000	.000
○	.340		.790				
□	.675						
◇	1.007						
△	1.285						

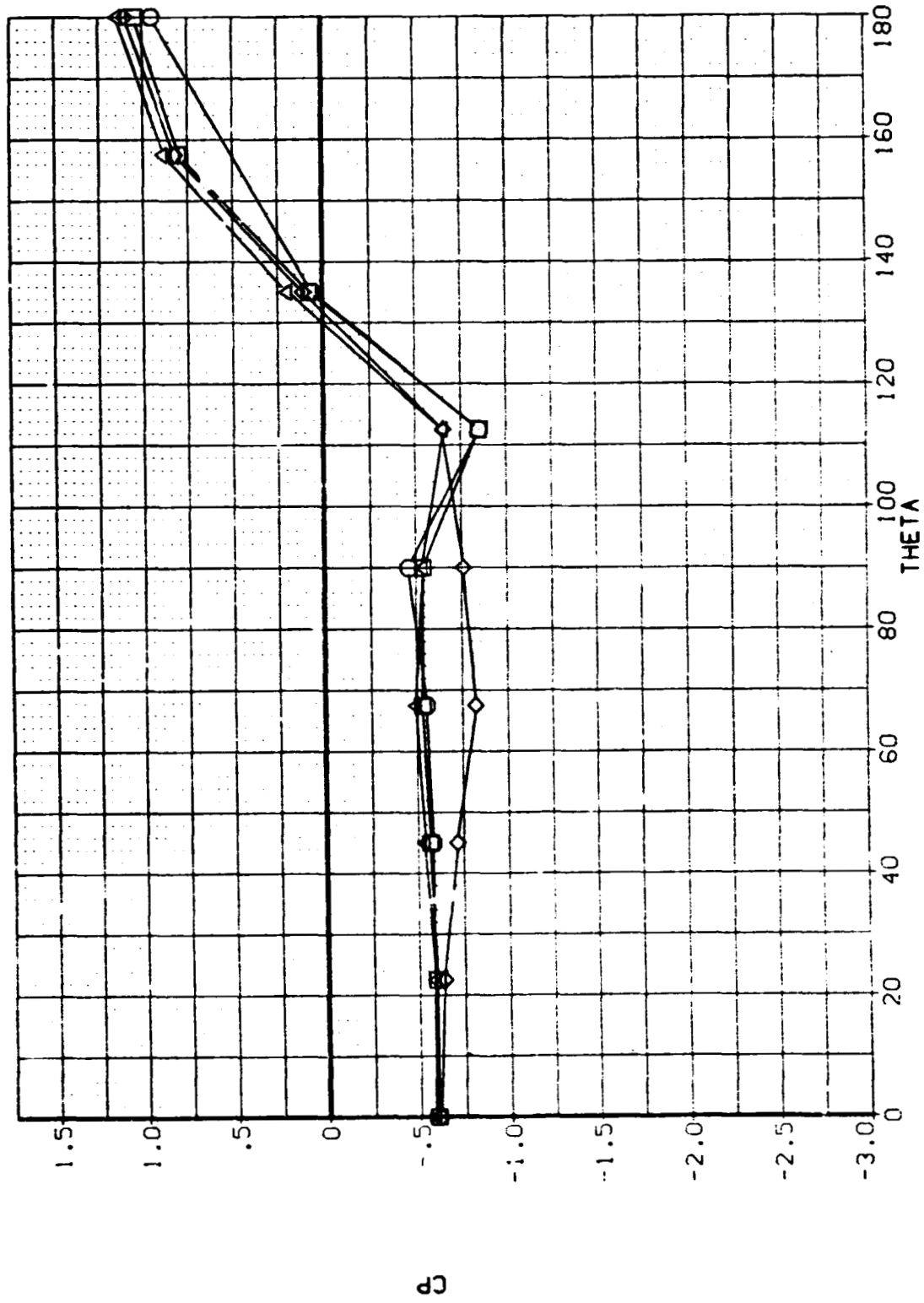

PRESSURE COEFFICIENT AROUND THE BODY AT VARIOUS STATIONS ALONG THE BODY

MSFC HRWT 033 (SA29F). SRB FORWARD NOSE SECTION (C1E103)

SYMBOL	X/D	ALPHA	MACH	BETA	PHI
○	.340	80.000	2.000	9.000	.000
□	.675				
◇	1.007				
△	1.285				

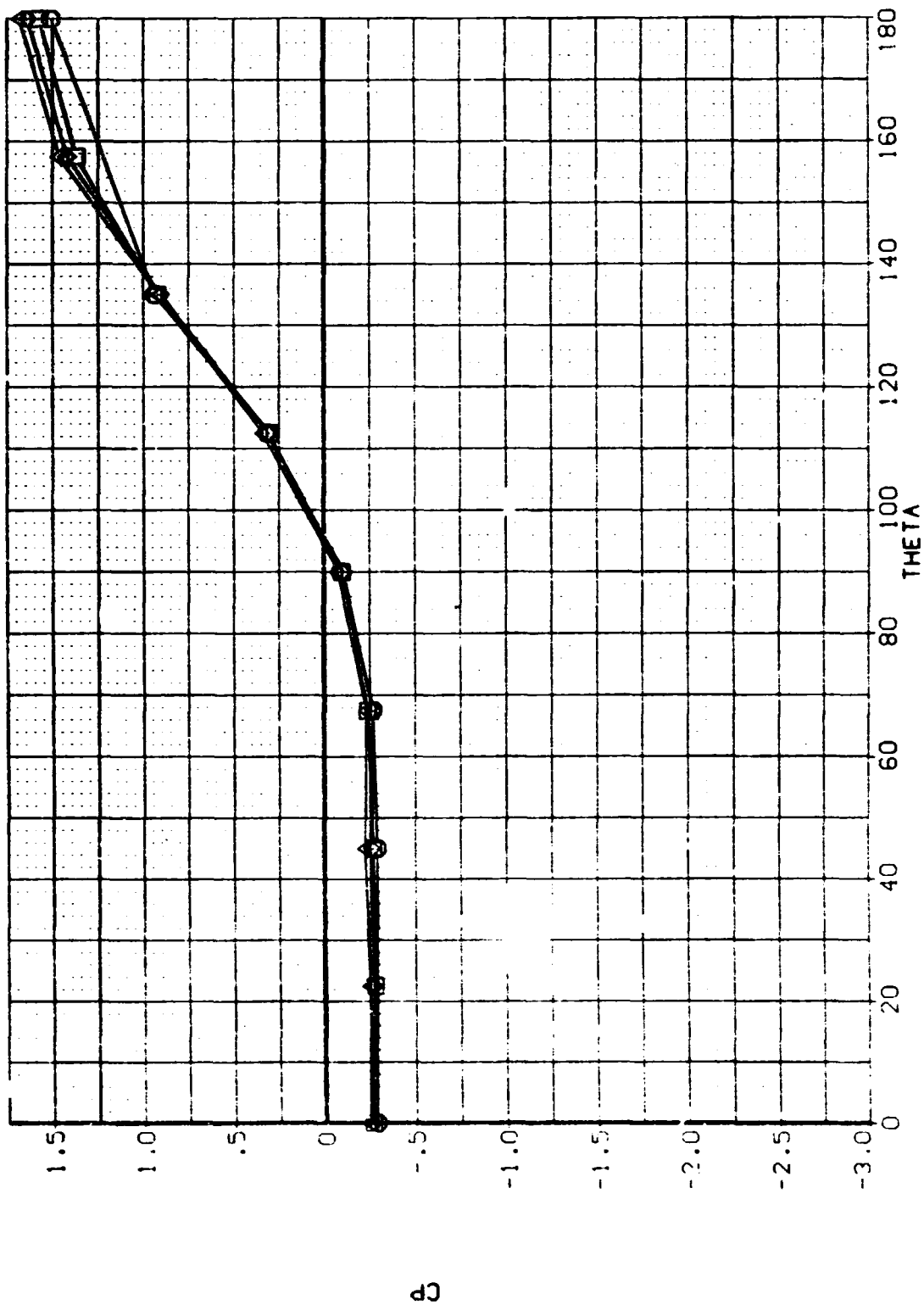

PRESSURE COEFFICIENT AROUND THE BODY AT VARIOUS STATIONS ALONG THE BODY

MSFC HWRT 03 (5A29F) SRB FORWARD NOSE SECTION (C1E101)

SYMBOL	X/D	ALPHA	MACH	BETA	PHI
○	.340	90.000	400	RN	.000
□	.675			RN	18.100
◇	1.007				
△	1.285				

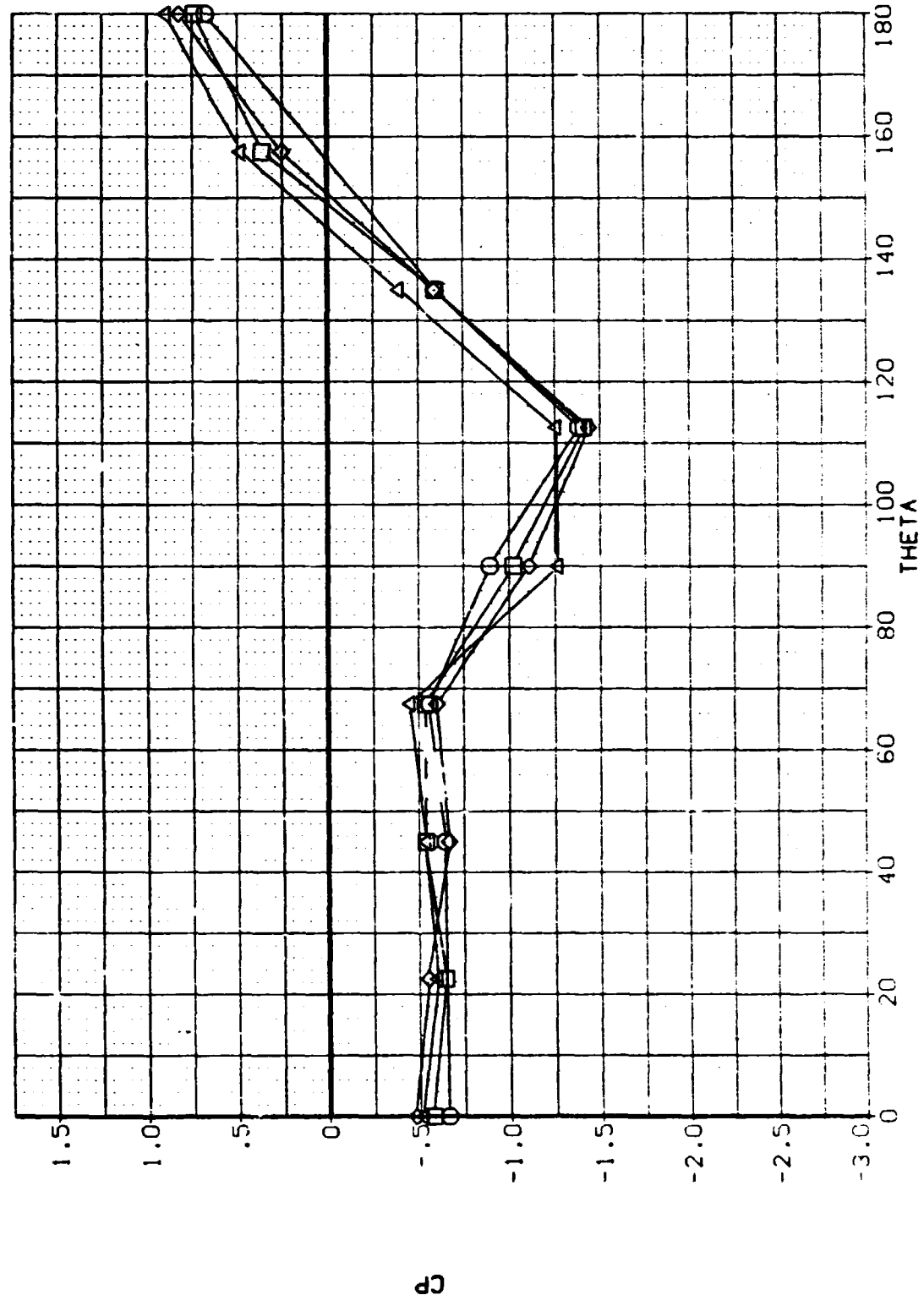

PRESSURE COEFFICIENT AROUND THE BODY AT VARIOUS STATIONS ALONG THE BODY

MSFC HRWT 033 (SA29F) SRB FORWARD NOSE SECTION (C1E101)

SYMBOL	X/D	ALPHA	MACH	BETA	PHI
	1.377	90.000	.400	18.100	.000
□	1.550				
◇	1.810				
△	2.160				

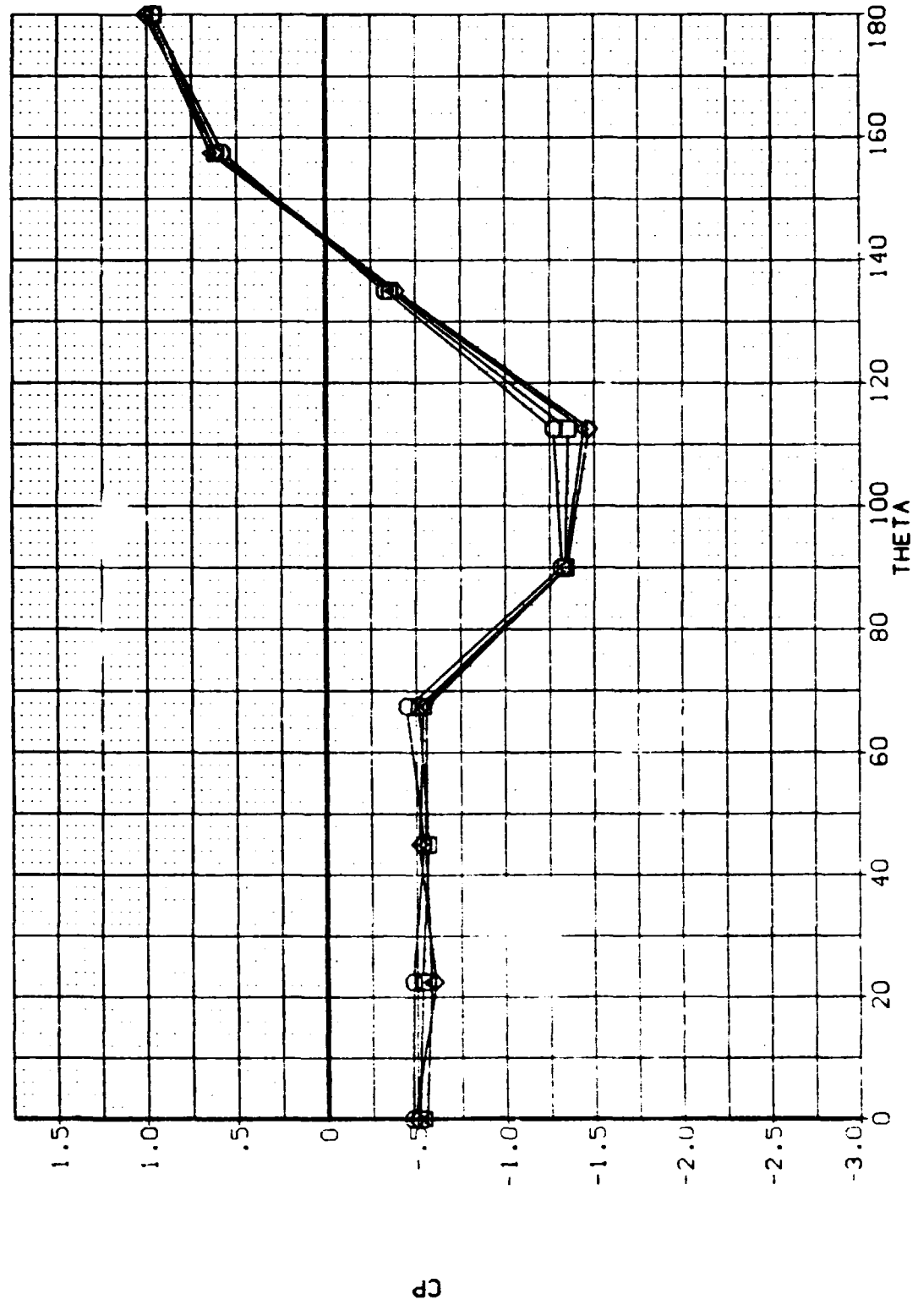

PRESSURE COEFFICIENT AROUND THE BODY AT VARIOUS STATIONS ALONG THE BODY

MSFC HRWT J33 (SA29F) SRB FORWARD NOSE SECTION (C1E102)

SYMBOL	X/D	ALPHA	MACH	BETA	PHI
○	.340	90.000	.490	RN	.000
□	.675			RN	18.100
◇	1.007				
△	1.285				

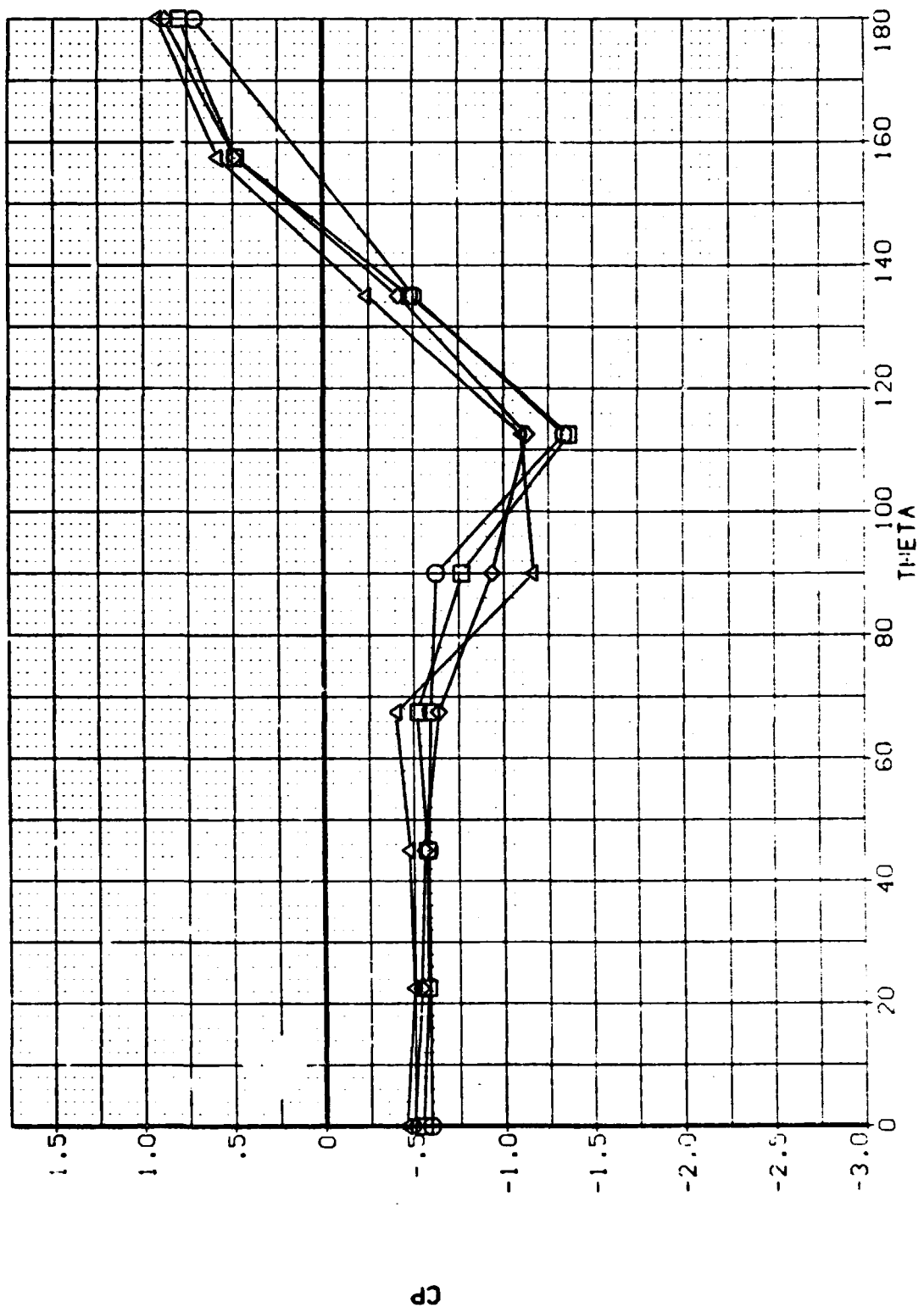

PRESSURE COEFFICIENT AROUND THE BODY AT VARIOUS STATIONS ALONG THE BODY

MSFC HRWT 033 (SA29F) SRB FORWARD NOSE SECTION (D1E101)

SYMBOL	X/D	ALPHA	MACH	BETA	PARAMETRIC VALUES
	.340	90.000	.600	RN	.000
□	.675				18.100
◇	1.007				
△	1.285				

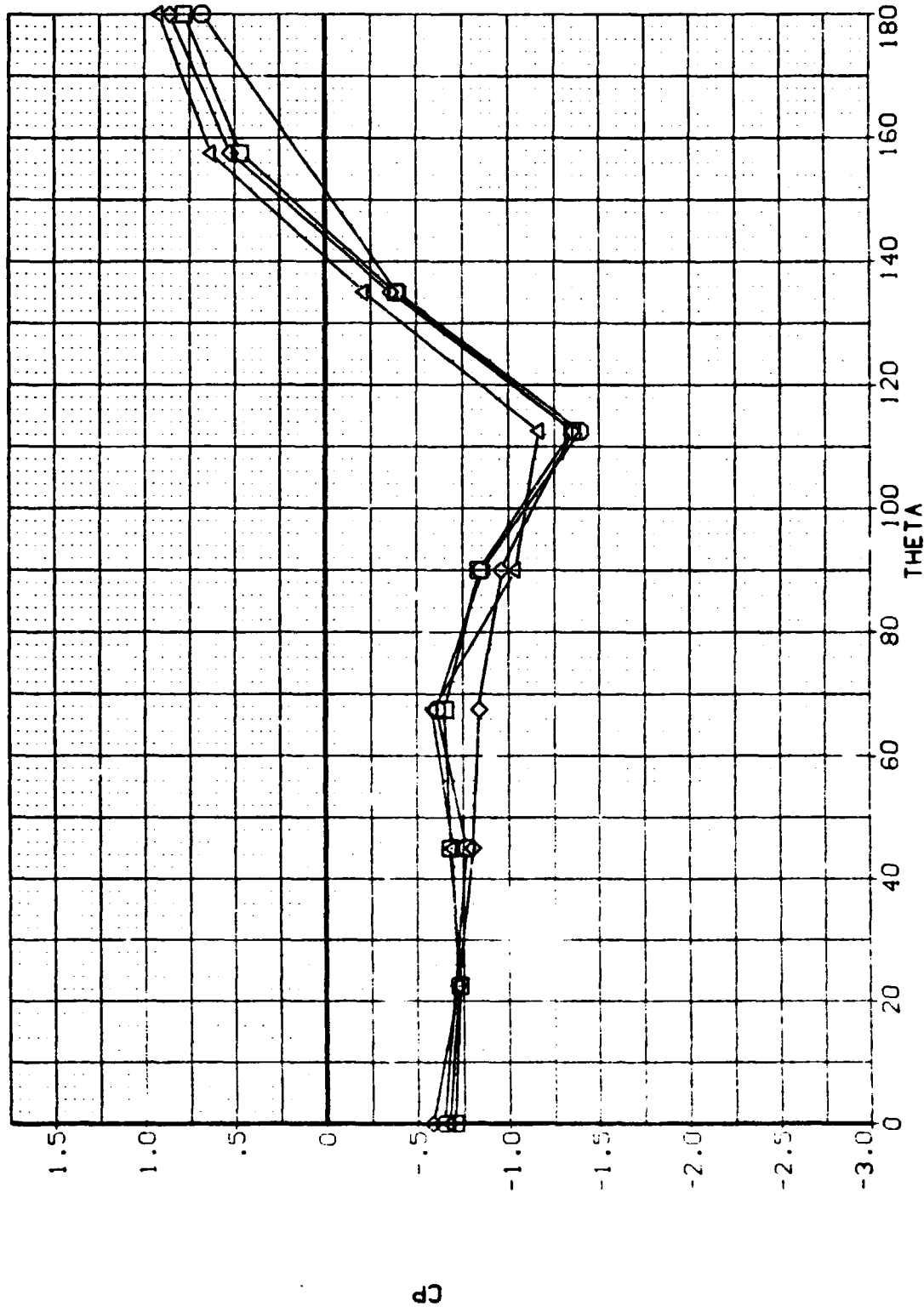

PRESSURE COEFFICIENT AROUND THE BODY AT VARIOUS STATIONS ALONG THE BODY

MSFC HRW: 033 (S:29F) SRB FORWARD NOSE SECTION (D1E101)

SYMBOL	X/D	ALPHA	MACH	BETA	PHI
○	1.377	90.000	.600	RN	.000
□	1.550				16.100
◇	1.810				
△	2.160				

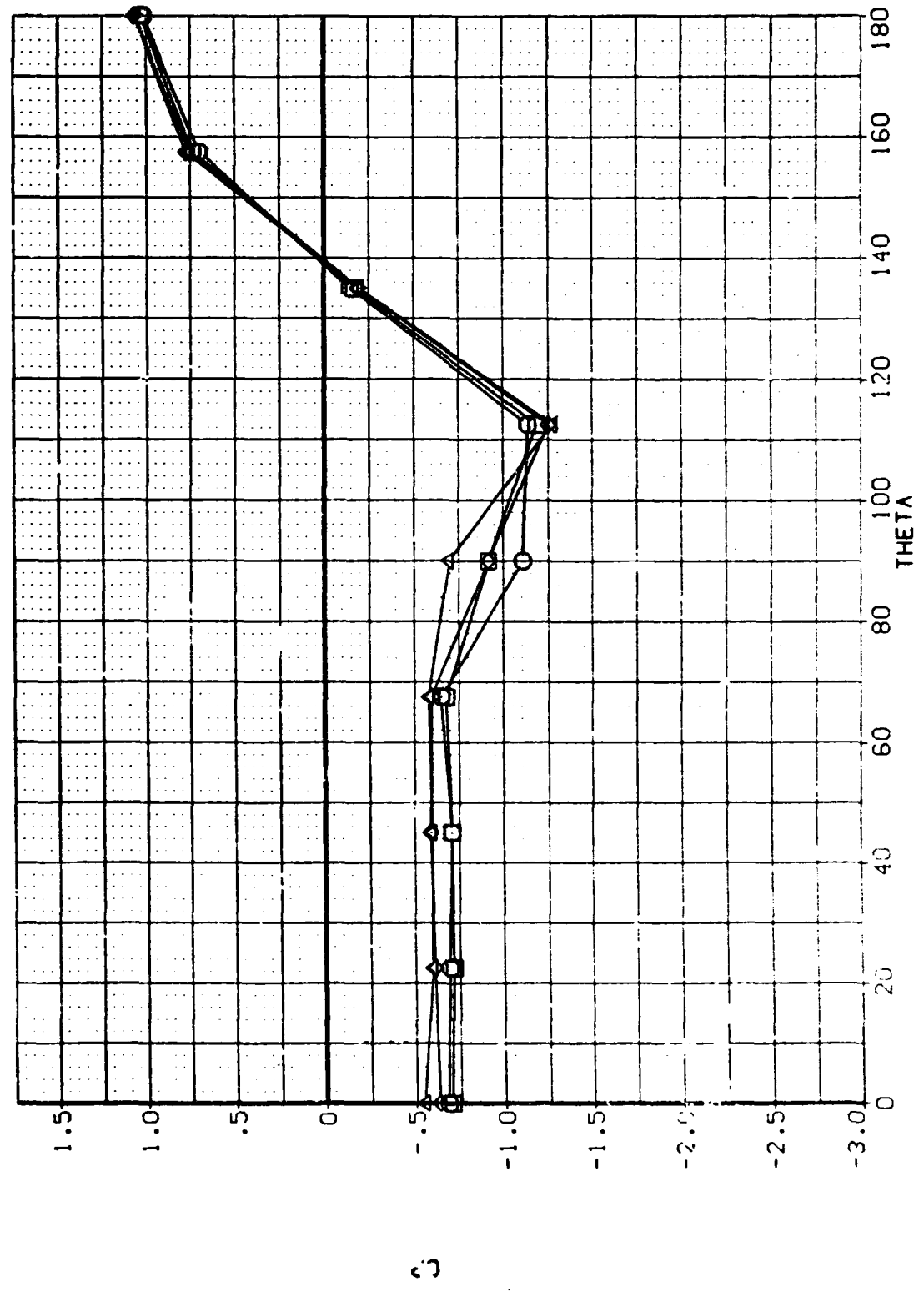

PRESSURE COEFFICIENT AROUND THE BODY AT VARIOUS STATIONS ALONG THE BODY

MSFC HRWT 033 (SA29F) SRB FORWARD NOSE SECTION (D1E101)

SYMBOL	X/D	ALPHA	MACH	BETA	PARAMETRIC VALUES
○	.340	90.000	.780	RN	.000 PHI .000
□	.675				18.100
◇	1.007				
△	1.285				

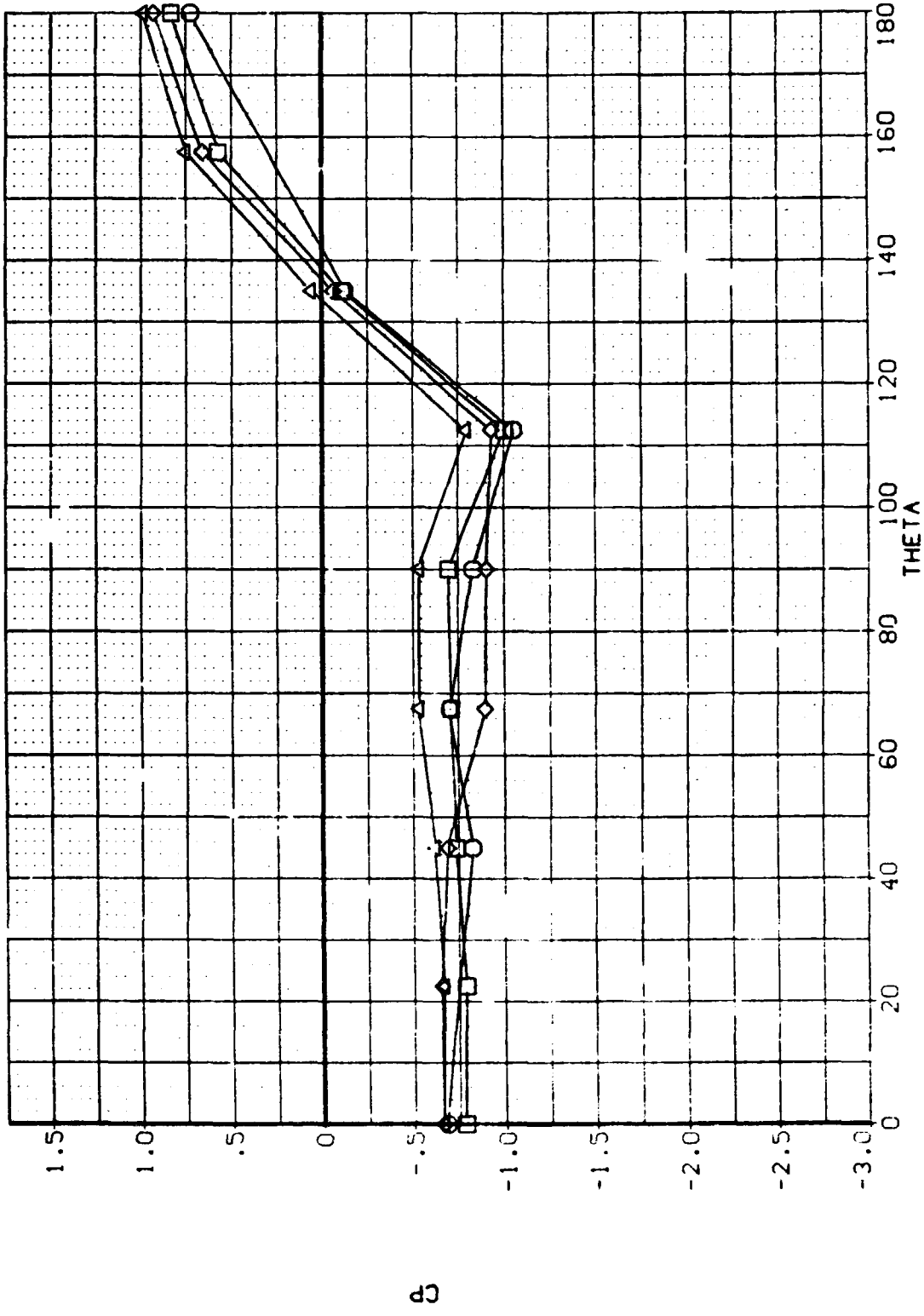

PRESSURE COEFFICIENT AROUND THE BODY AT VARIOUS STATIONS ALONG THE BODY

MSFC HRWT 033 (S429F) SRB FORWARD NOSE SECTION (DIE101)

SYMBOL	X/D	ALPHA	MACH	BETA	PHI
○	1.377	90.000	.780	RN	.000
□	1.550			18.100	
◇	1.810				
△	2.160				

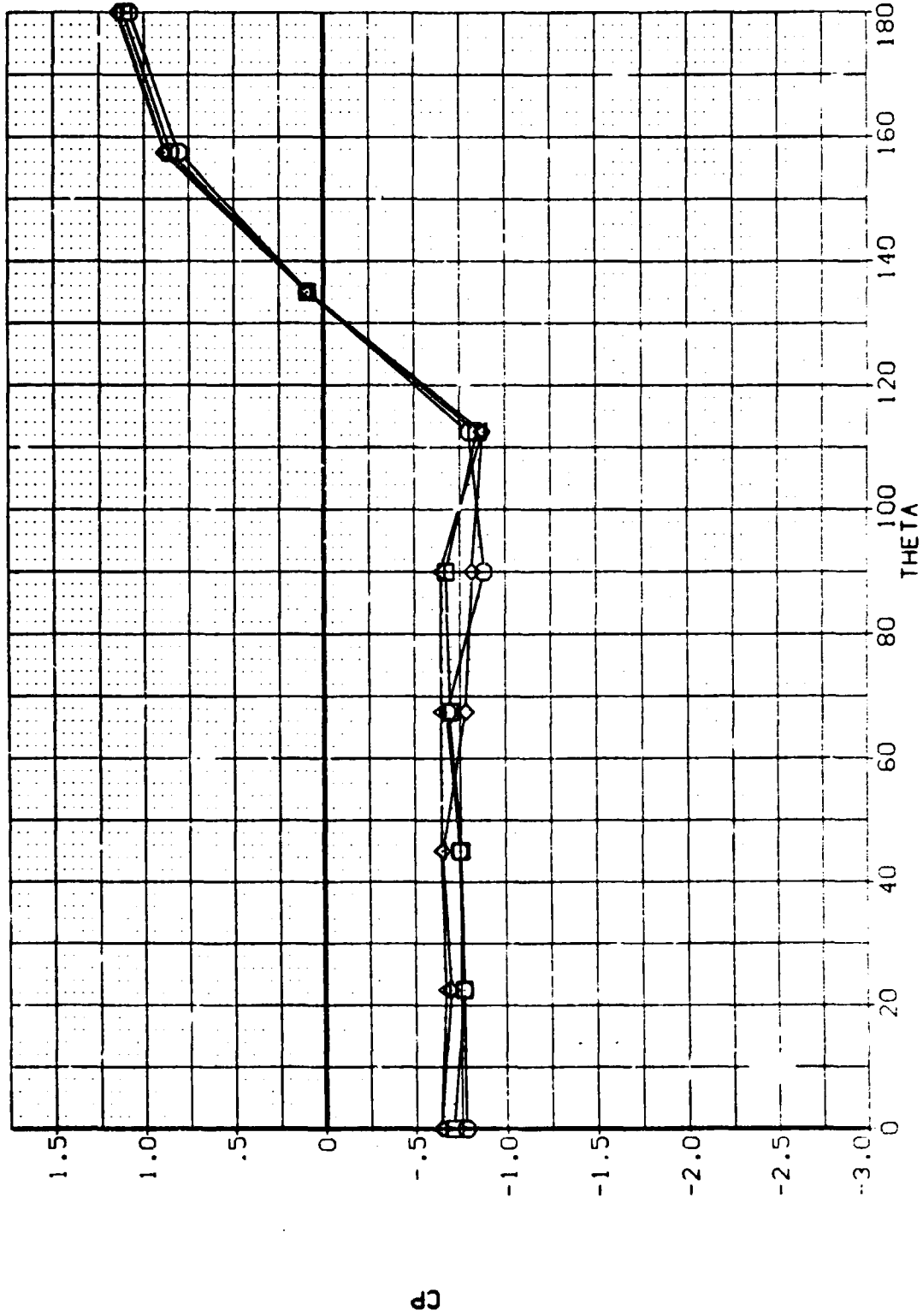

PRESSURE COEFFICIENT AROUND THE BODY AT VARIOUS STATIONS ALONG THE BODY

MSFC H. J33 (SA29F) SRB FORWARD NOSE SECTION (DIE103)

SYMBOL	X/D	PARAMETRIC VALUES	
		ALPHA	PHI
○	.340	90.000	.000
□	.675	90.000	.000
◇	1.007	9.000	.000
△	1.285	9.000	.000

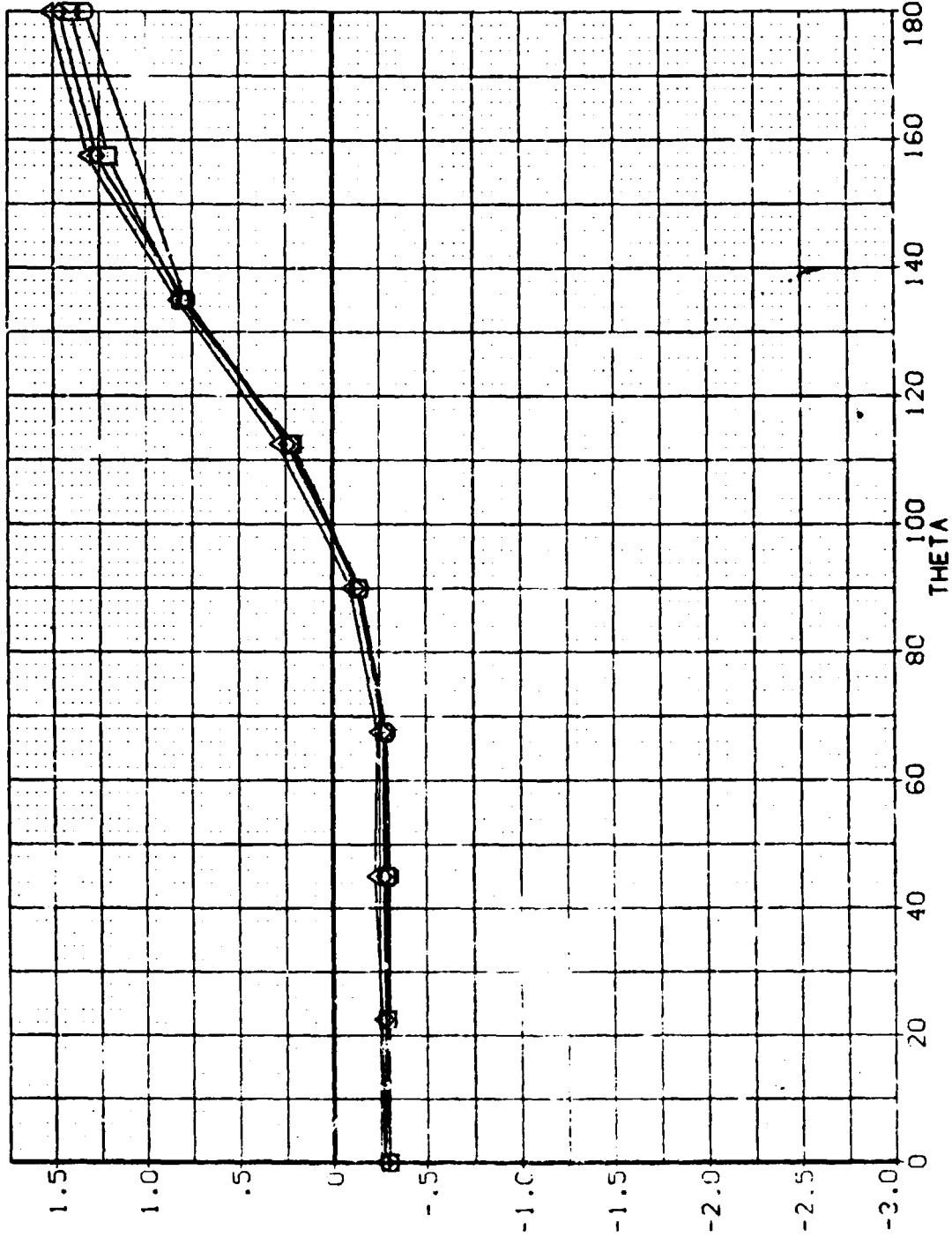

93

MSFC HRWT J33 (SA29F) SPS FORWARD NOSE SECTION (D1E102)

SYMBOL	X,0	ALPHA	MACH	BETA	PHI
C	.340	100.000	.500	18.100	.000
□	.675				
◇	1.007				
△	1.285				

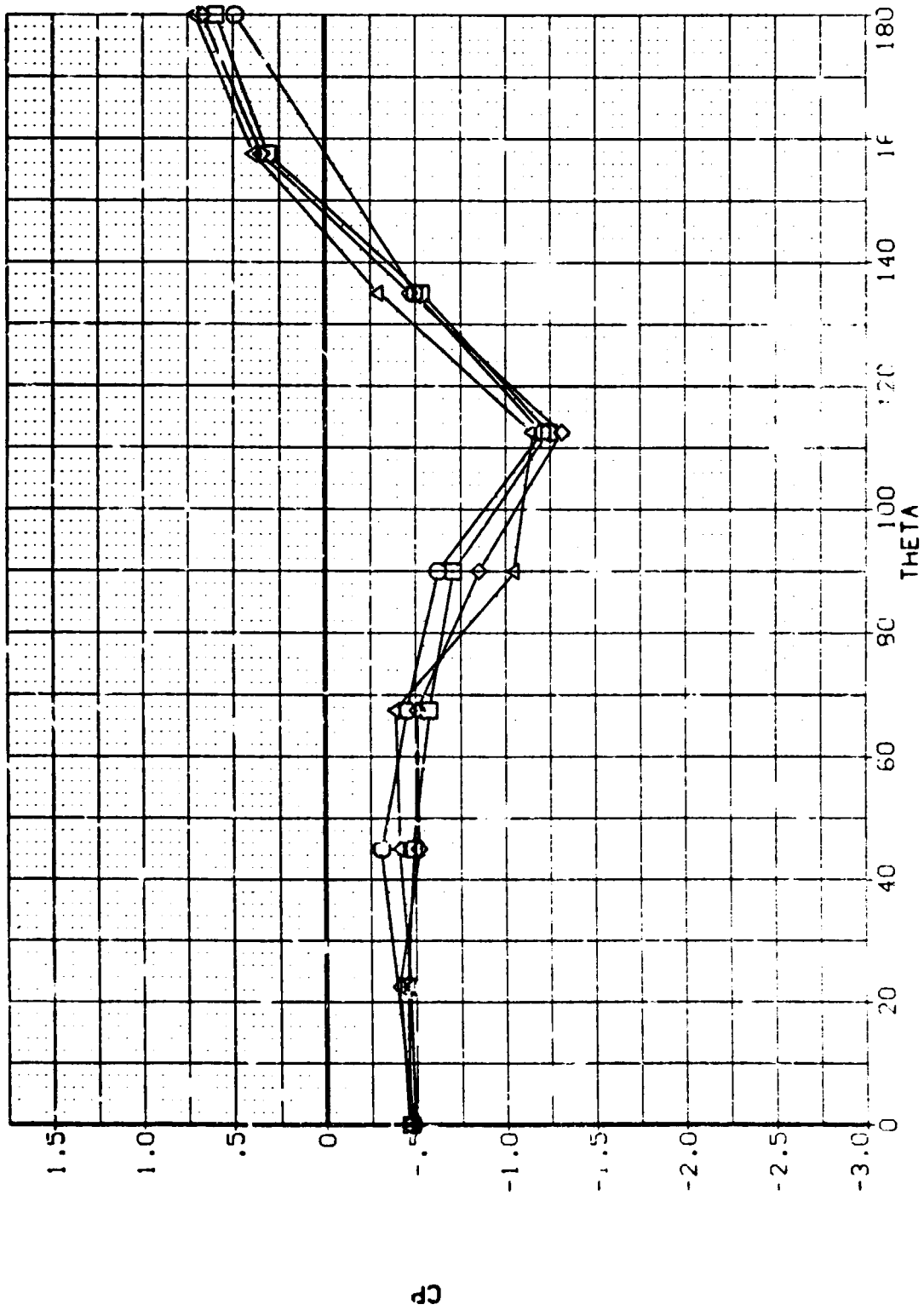

PRESSURE COEFFICIENTS AROUND THE BODY AT VARIOUS STATIONS ALONG THE BODY

MSFC HRWT 033 (SA29F) SRB FORWARD NOSE SECTION (01E102)

SYMBOL
 ○ □ ◇

X/D ALPHA MACH
 .340 100.000 .600
 .675
 1.007
 1.265

BETA RN
 18.100
 .000 PMI
 .000

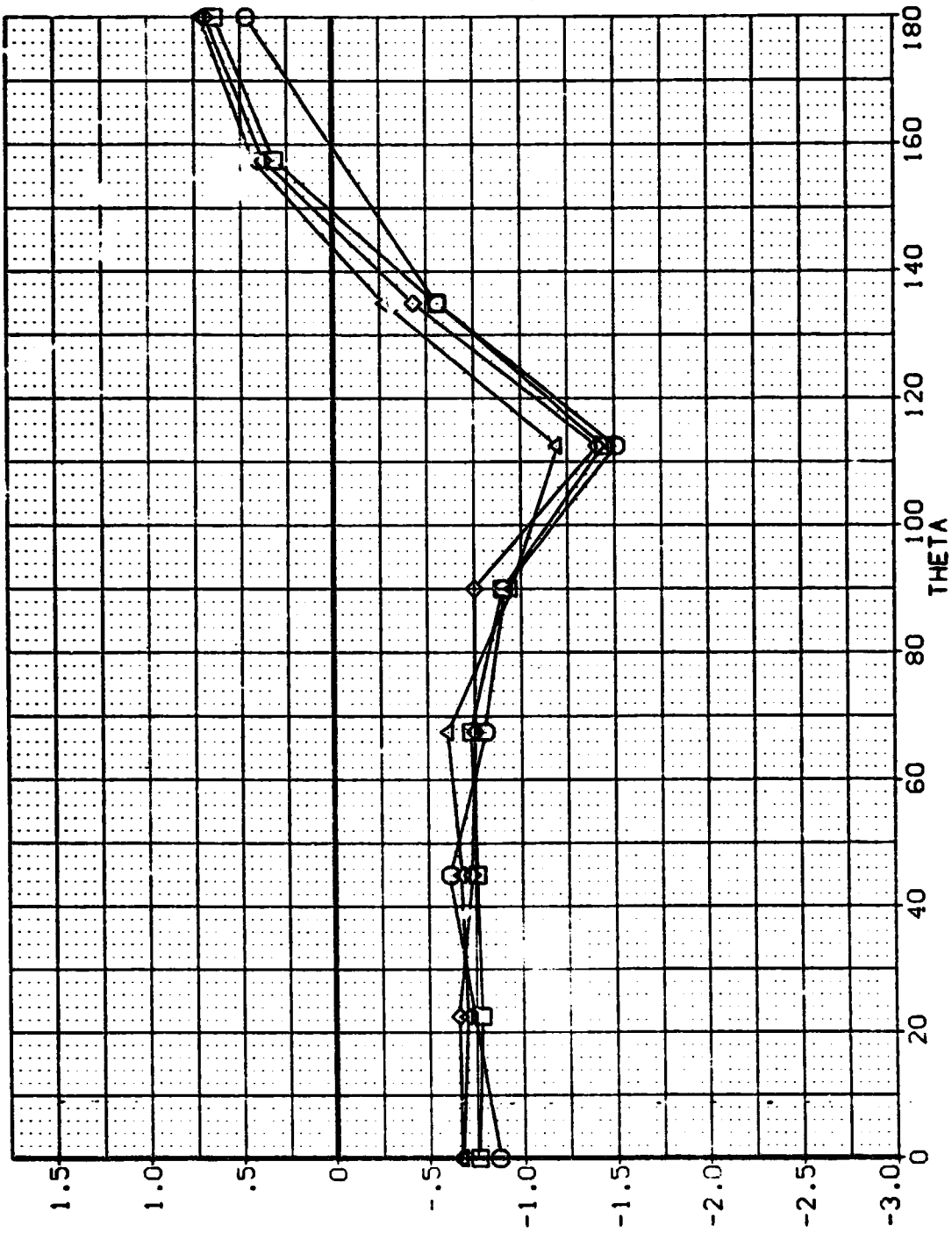

PRESSURE COEFFICIENT AROUND THE BODY AT VARIOUS STATIONS ALONG THE BODY

62

MSFC HRWT 033 (SA29F) SRB FORWARD NOSE SECTION (D1E102)

SYMBOL	X/D	ALPHA	MACH	BETA	PHI
□	.340	100.000	.790	RN	.000
◇	.675				18.100
△	1.007				
△	1.285				

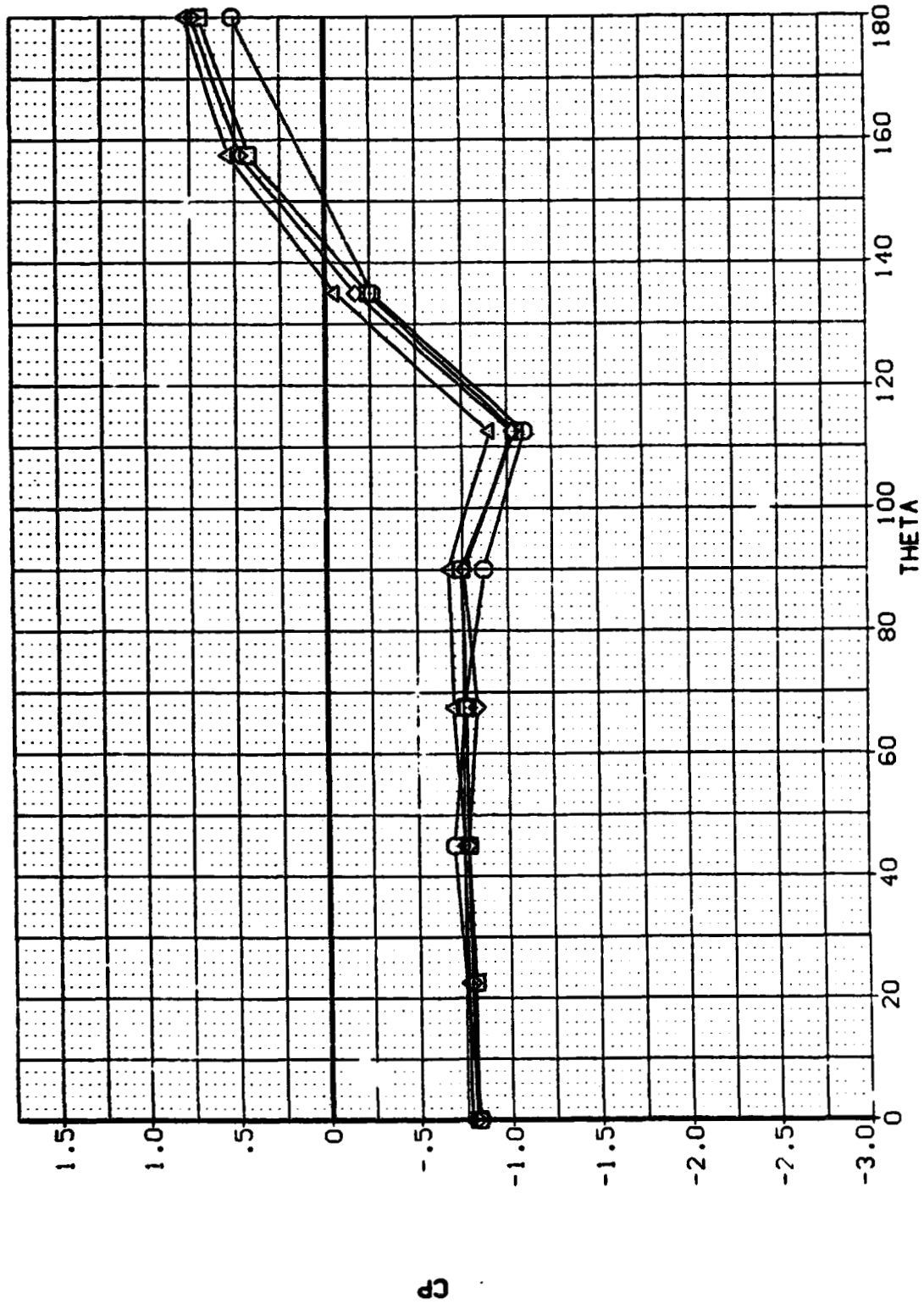

PRESSURE COEFFICIENT AROUND THE BODY AT VARIOUS STATIONS ALONG THE BODY

MSFC HRWT 033 (SA29F) SRB FORWARD NOSE SECTION (E1E103)

SYMBOL	X/D	ALPHA	MACH	BETA	PHI
○	.340	100.000	2.000	RN	.000
□	.675				
◇	1.007				
△	1.285				

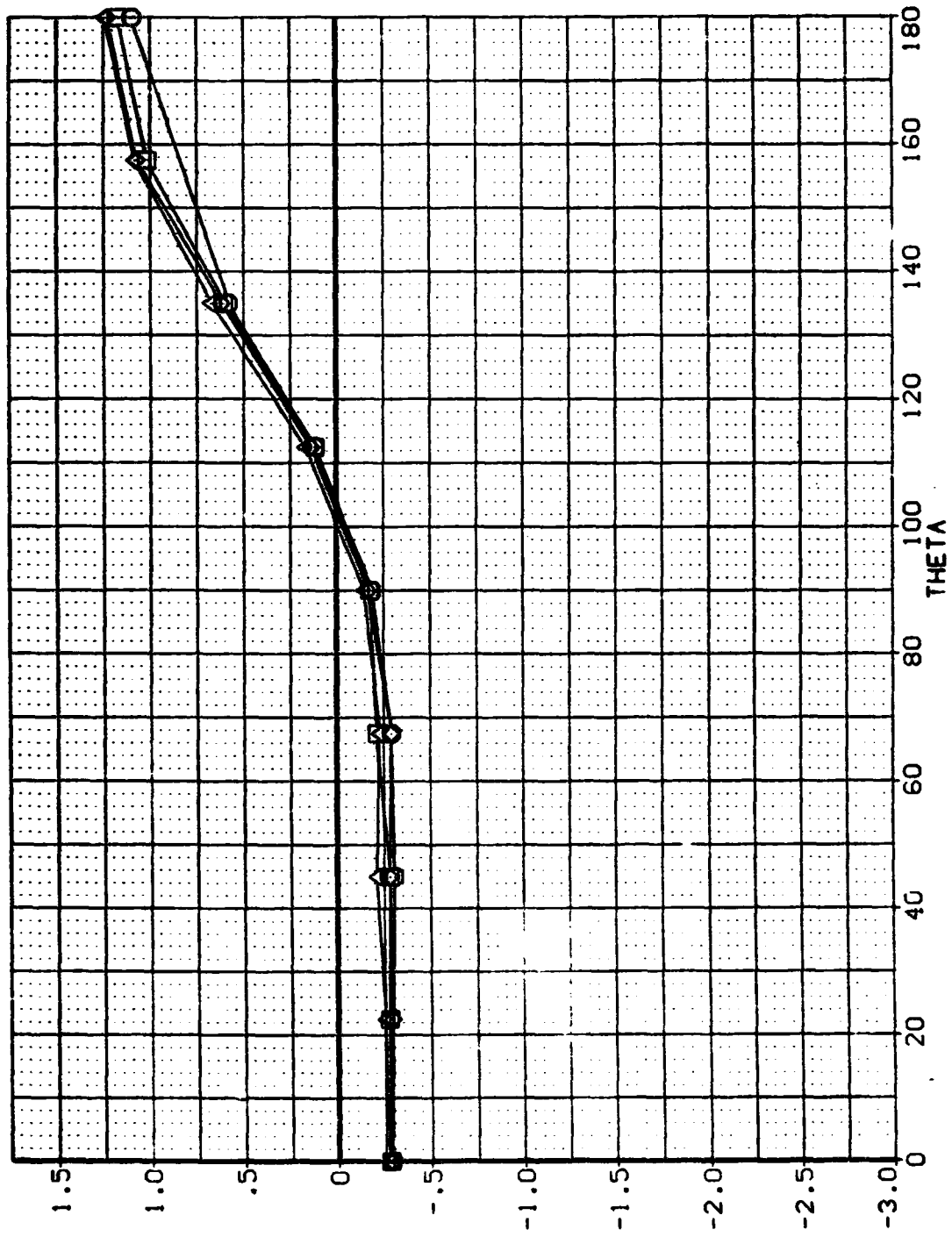

PRESSURE COEFFICIENT AROUND THE BODY AT VARIOUS STATIONS ALONG THE BODY

MSFC HRWT 033 (SA29F) SRB FORWARD NOSE SECTION (E1E101)

SYMBOL	X/D	ALPHA	MACH	BETA	PARAMETRIC VALUES
○	.340	107.900	.410	RN	.000 PHI
□	.675				19.100
◇	1.007				
△	1.285				

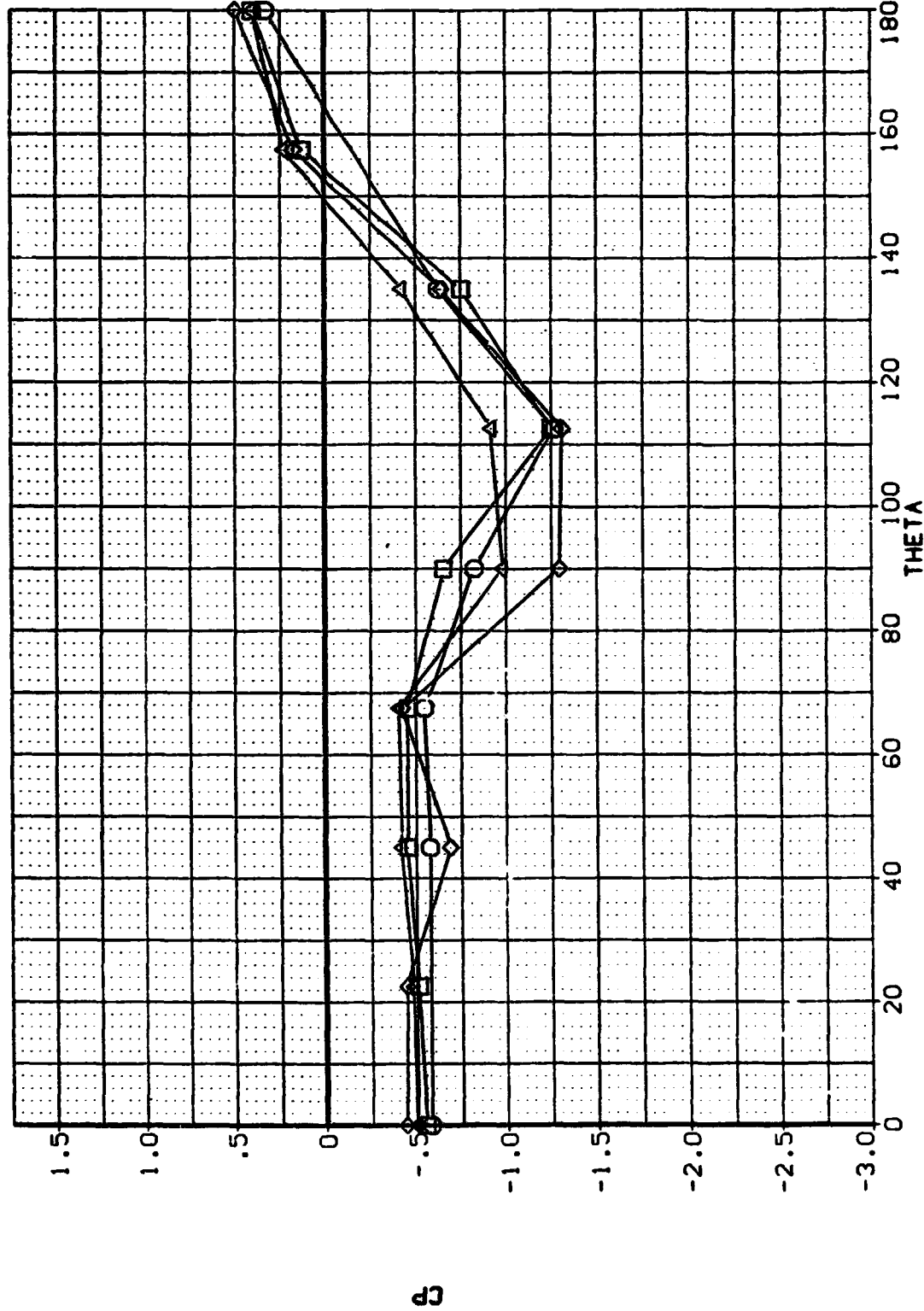

PRESSURE COEFFICIENT AROUND THE BODY AT VARIOUS STATIONS ALONG THE BODY

MSFC HRWT 033 (SA29F) SRB FORWARD NOSE SECTION (E1E101)

SYMBOL	X/D	ALPHA	MACH	BETA	PARAMETRIC VALUES
□	1.377	107.900	.410	RN	.000 PHI
○	1.550			16.100	.000
◇	1.810				
△	2.160				

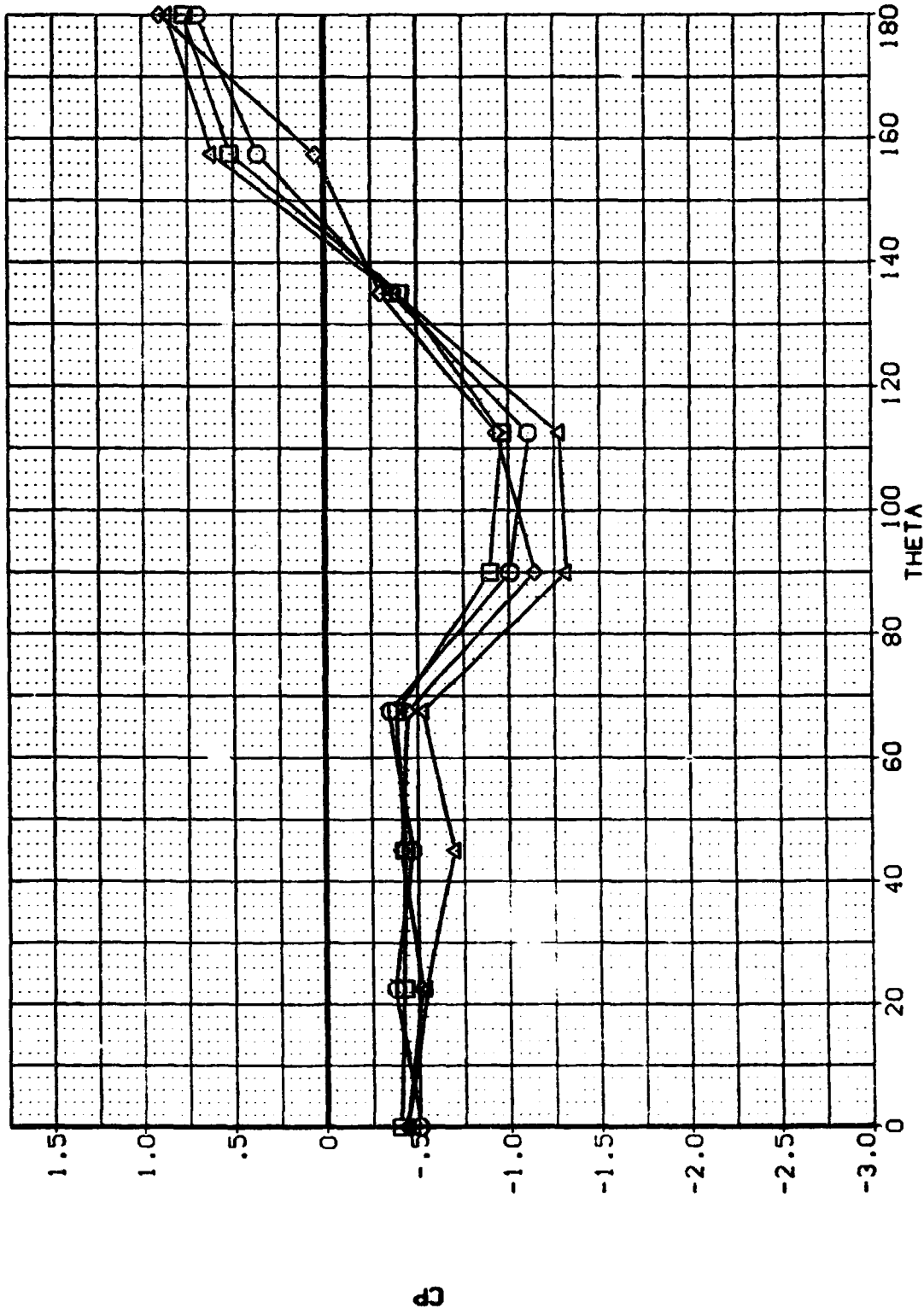

PRESSURE COEFFICIENT AROUND THE BODY AT VARIOUS STATIONS ALONG THE BODY

MSFC HRWT 033 (SΛ29F) SRB FORWARD NOSE SECTION (E1E102)

SYMBOL	X/D	ALPHA	MACH	BETA	PHI
○	.340	108.000	.500	RN	18.100
□	.675				.000
◇	1.007				
△	1.285				

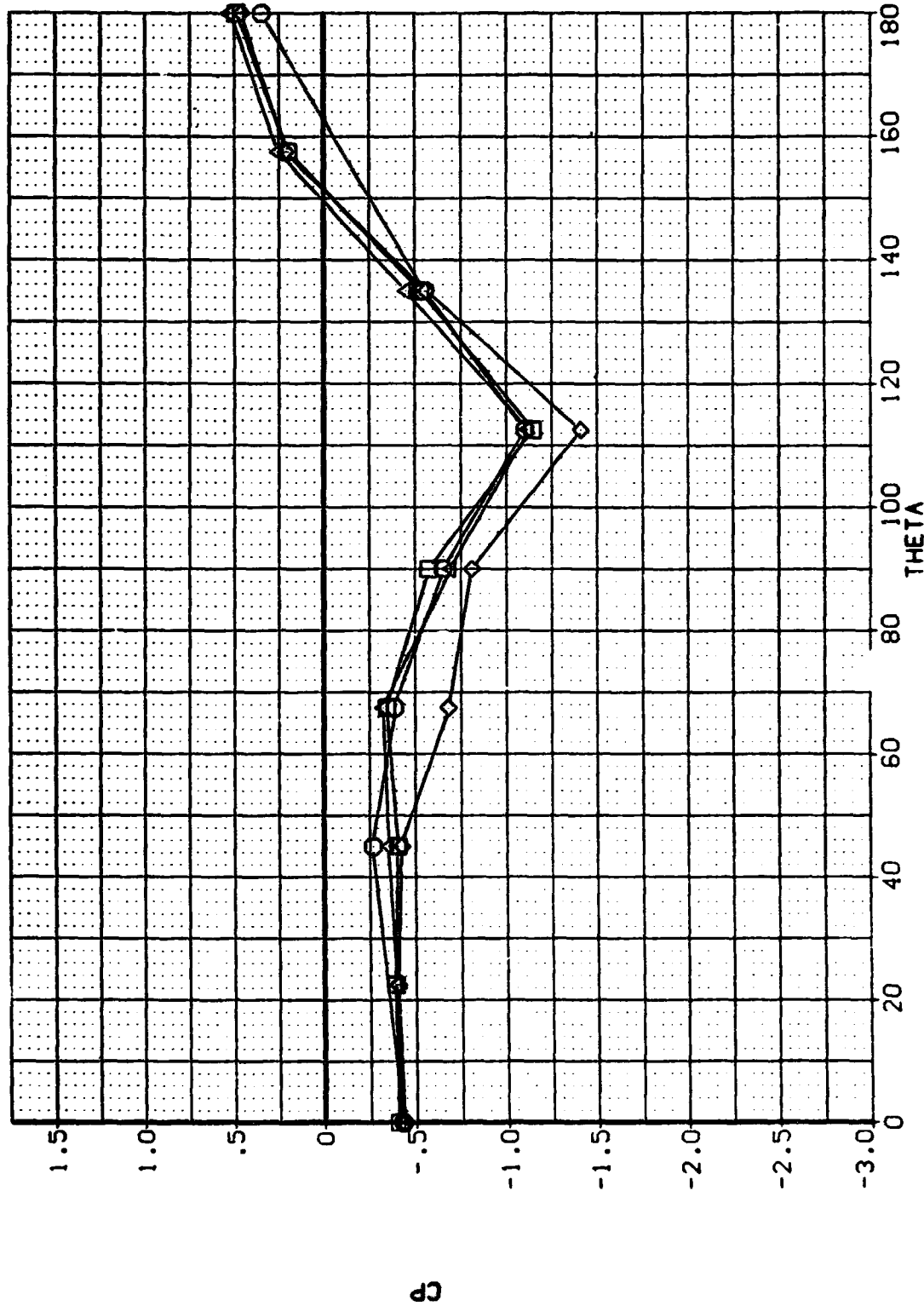

PRESSURE COEFFICIENT AROUND THE BODY AT VARIOUS STATIONS ALONG THE BODY

MSFC HRWT 033 (SA29F) SRB FORWARD NOSE SECTION (F1E101)

SYMBOL	X/D	ALPHA	MACH	BETA	PHI
○	.340	107.900	.610	RN	.000
□	.675			18.100	
◇	1.007				
△	1.285				

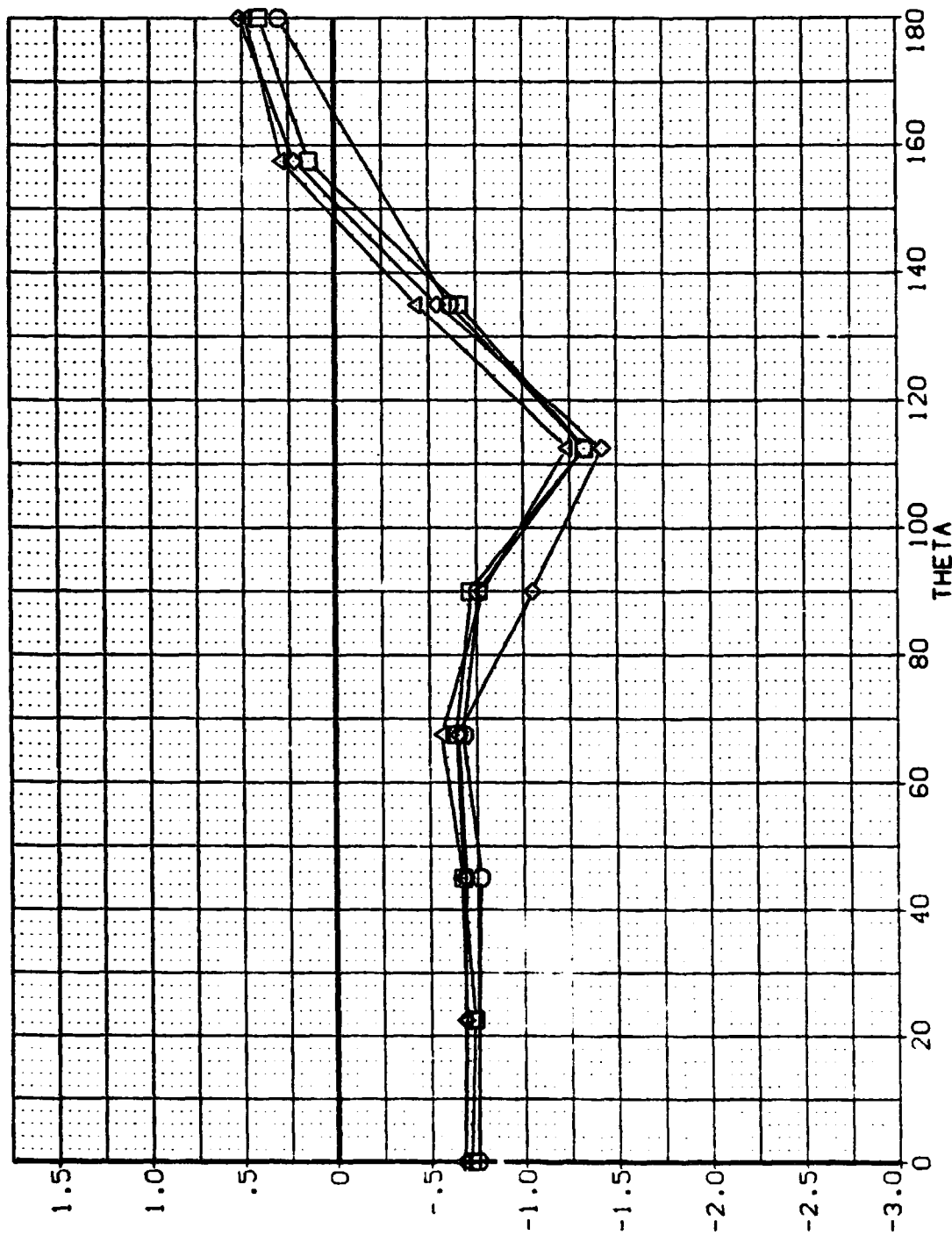

PRESSURE COEFFICIENT AROUND THE BODY AT VARIOUS STATIONS ALONG THE BODY

MSFC HRW 033 (SA29F) SRB FORWARD NOSE SECTION (F1E101)

SYMBOL	X/D	ALPHA	MACH	BETA	PHI
○	1.377	107.900	.610	RN	.000
□	1.550			RN	18.100
◇	1.810				
△	2.160				

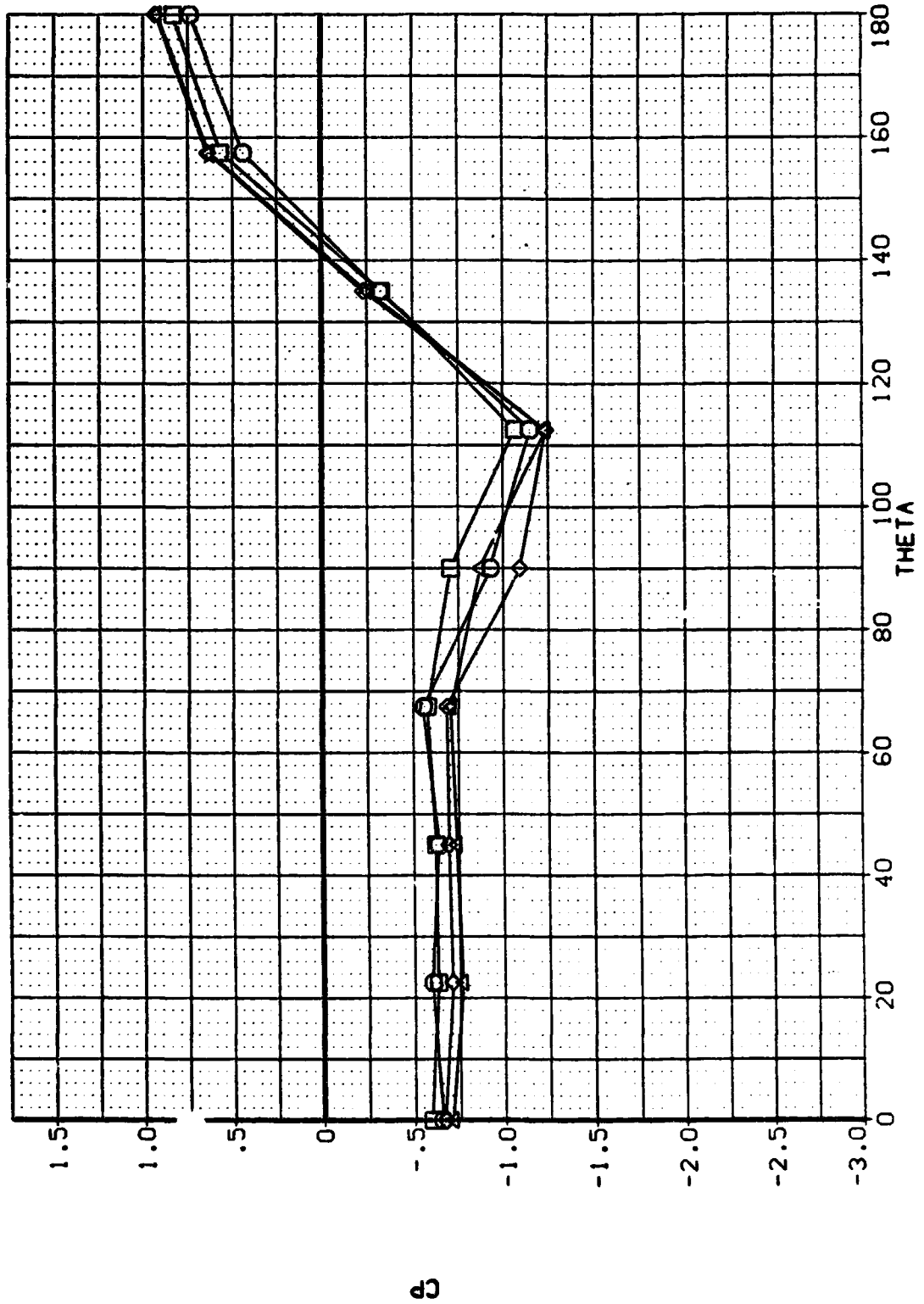

PRESSURE COEFFICIENT AROUND THE BODY AT VARIOUS STATIONS ALONG THE BODY

MSFC HRWT 033 (SA29F) SRB FORWARD NOSE SECTION (F1E101)

SYMBOL	X/D	ALPHA	MACH	BETA	PHI
○	.340	107.900	.760	RN	.000
□	.675				18.100
◇	1.007				
△	1.285				

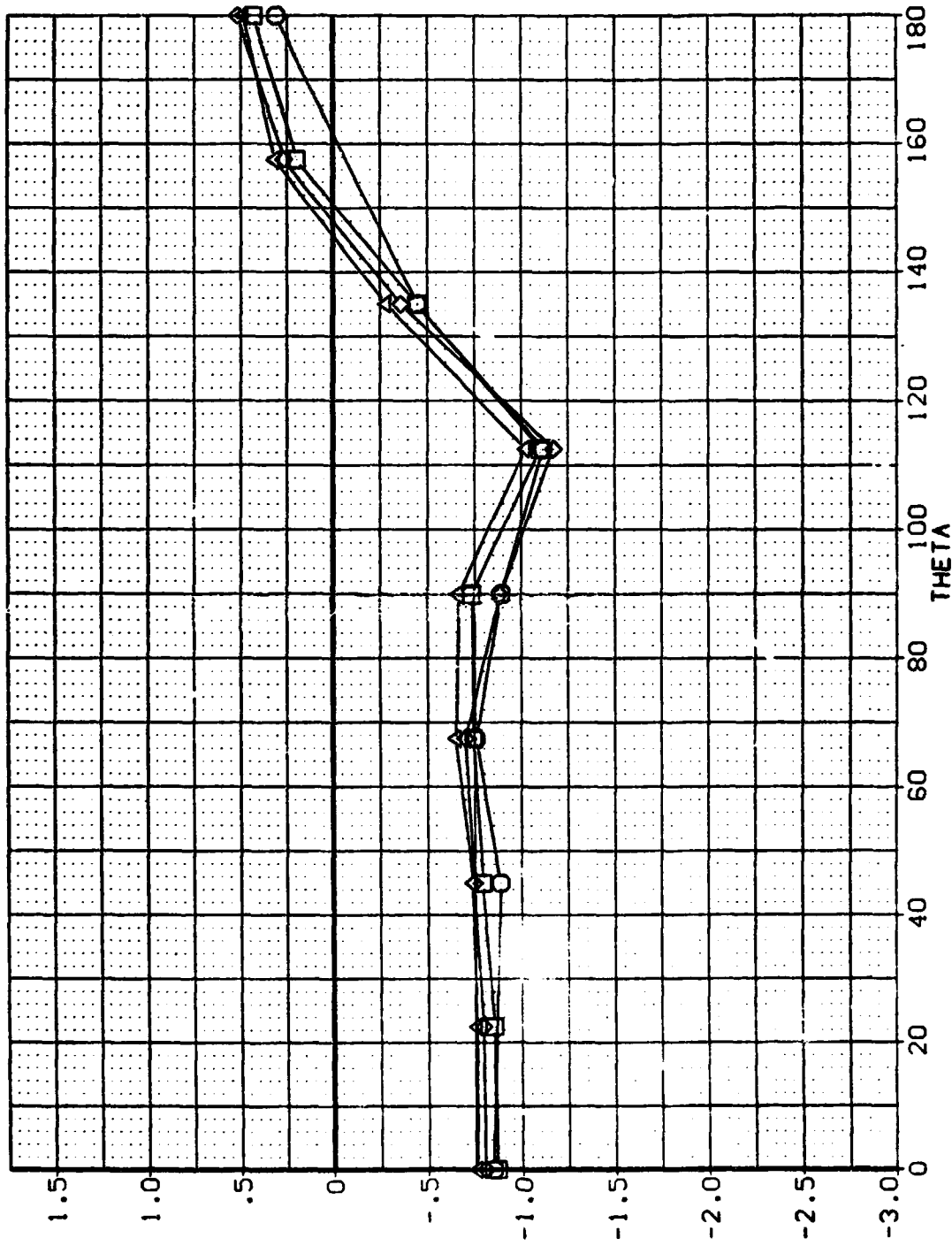

PRESSURE COEFFICIENT AROUND THE BODY AT VARIOUS STATIONS ALONG THE BODY

MSFC HRWT 033 (SA29F) SRB FORWARD NOSE SECTION (F1E101J)

SYMBOL	K/D	ALPHA	MACH	BET'	PHI
○	1.377	107.900	.760	RN	.000
□	1.550			18.100	
◇	1.810				
△	2.160				

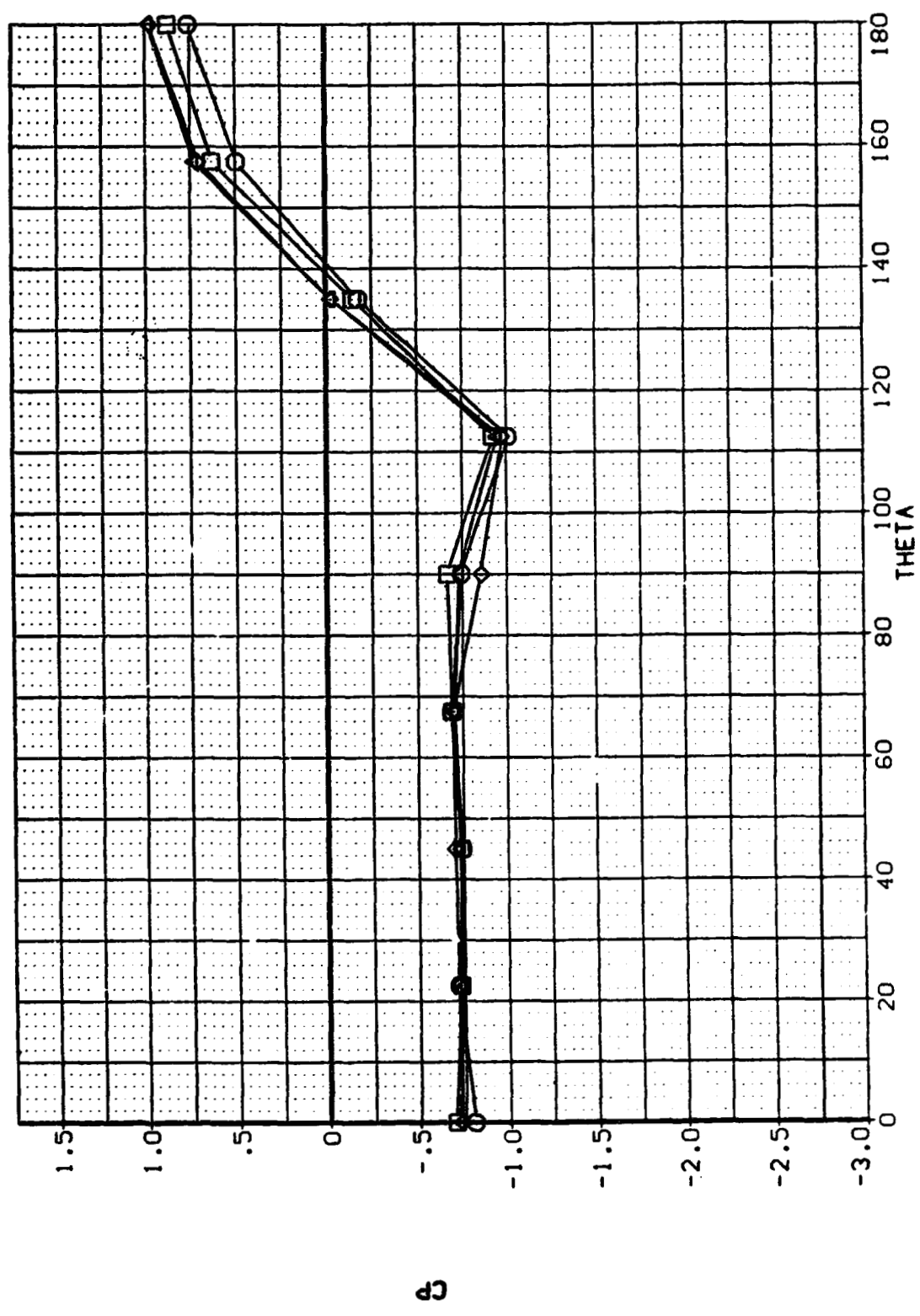

PRESSURE COEFFICIENT AROUND THE BODY AT VARIOUS STATIONS ALONG THE BODY

MSFC HRWT 033 (SA29F) SRB FORWARD NOSE SECTION (F1E103)

SYMBOL	X/D	ALPHA	MACH	BETA	PARAMETRIC VALUES
○	.340	108.000	2.000	RN	.000 PHI
□	.875				9.000
◇	1.007				
△	1.285				

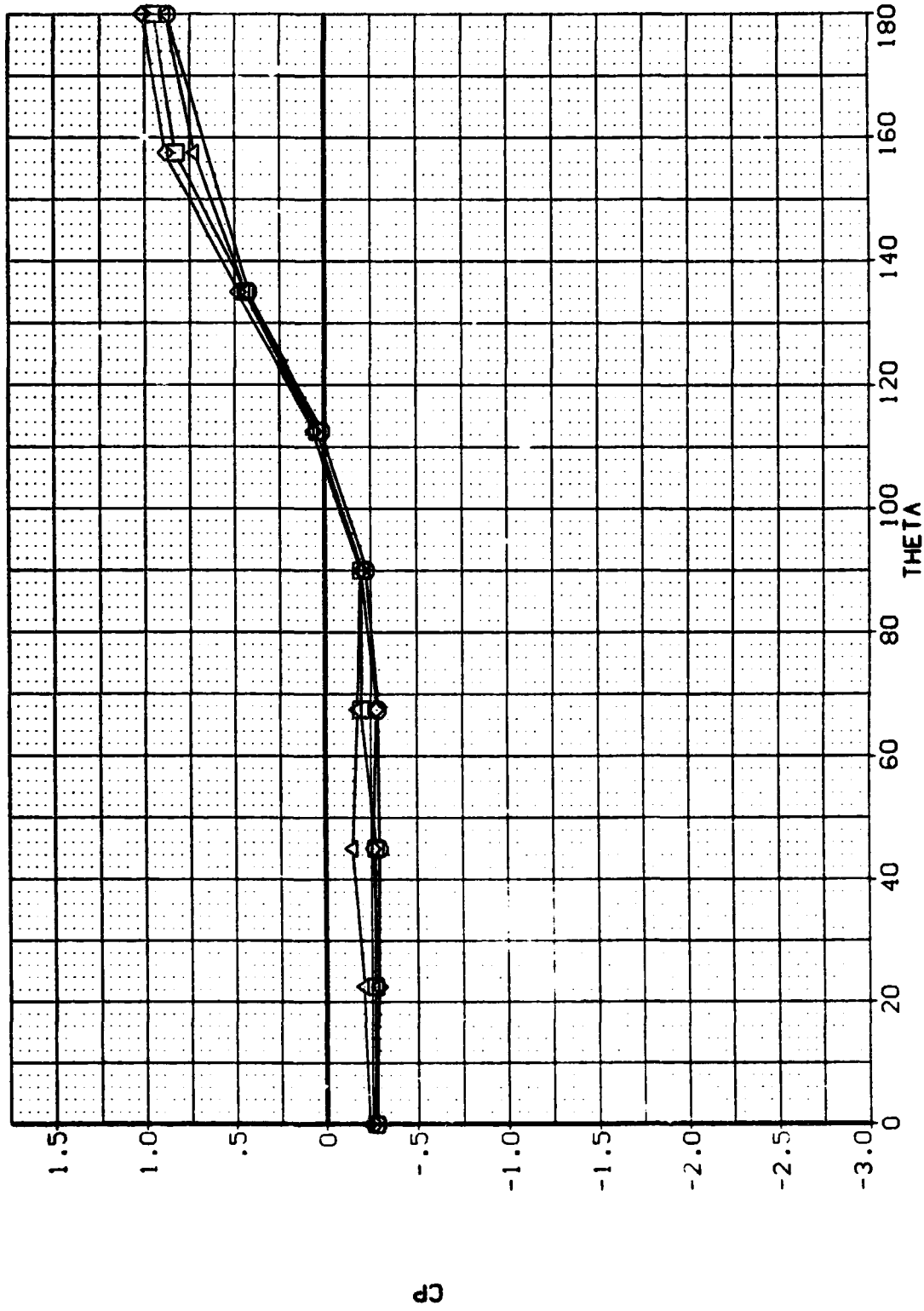

PRESSURE COEFFICIENT AROUND THE BODY AT VARIOUS STATIONS ALONG THE BODY

MSFC HRWT 033 (S429F) SRB FORWARD NOSE SECTION (RIE105)

SYMBOL	RN	X/D	ALPHA	BETA	PHI
○	2.250	1.810	90.000	MACH	180.000
□	10.217				.400

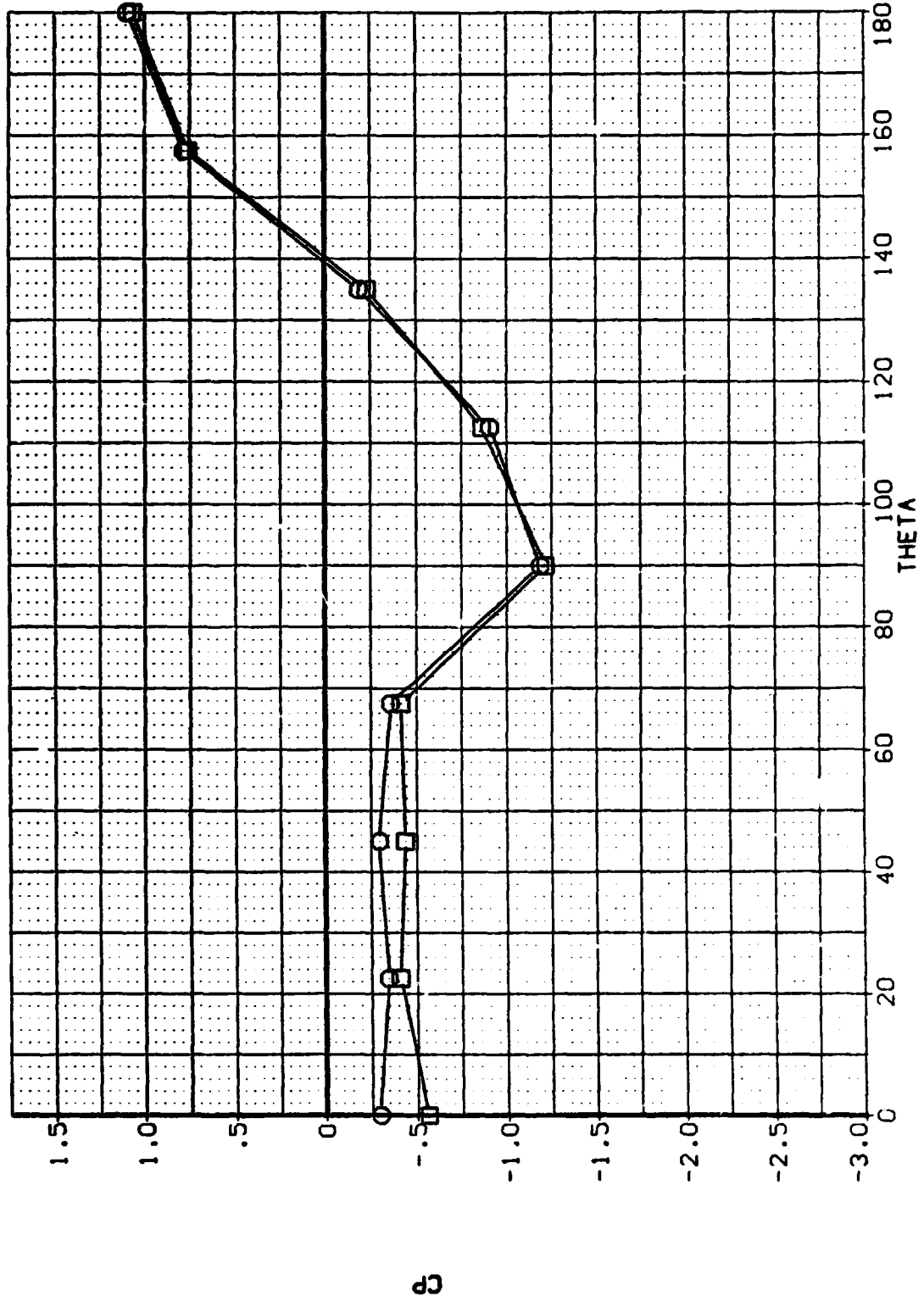

EFFECT OF REYNOLDS NUMBER ON PRESSURE COEFFICIENTS AT VARIOUS BODY STATIONS

MSFC HRWT 033 (SA29F) SRB FORWARD NOSE SECTION (R1E105)

SYMBOL
 ○
 □

RN 2.250
 10.217

K/D 2.160
 ALPHA 90.000

BETA MACH

PARAMETRIC VALUES
 .000 PHI 180.000
 .400

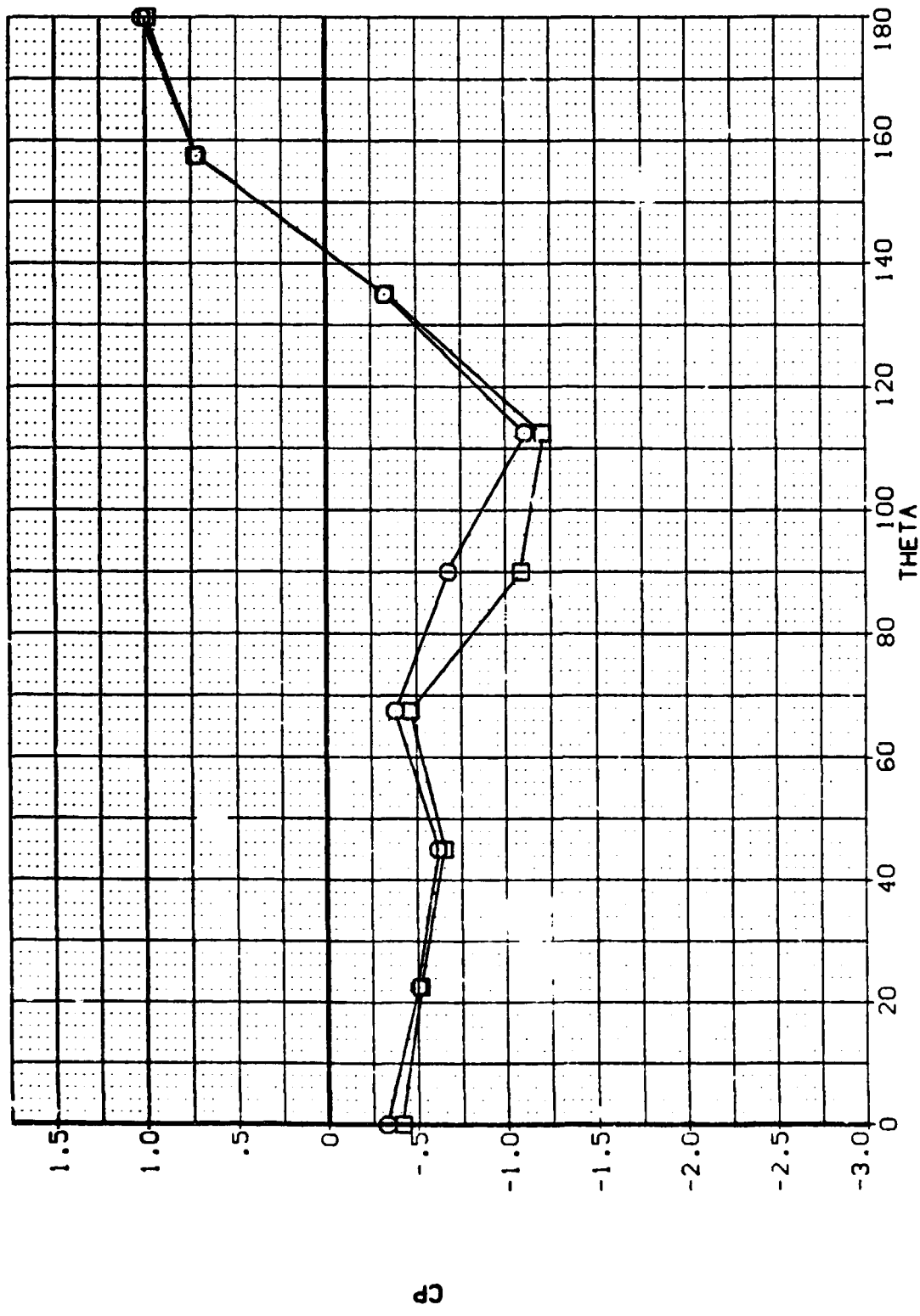

EFFECT OF REYNOLDS NUMBER ON PRESSURE COEFFICIENTS AT VARIOUS BODY STATIONS

MSFC HRWT 033 (SA29F) SRB FORWARD NOSE SECTION (R1E105)

SYMBOL	RN	X/D	ALPHA	BETA	PHI
○	4.017	1.810	270.000	MACH	180.000
□	6.087				.400
◇	7.517				
△	9.017				

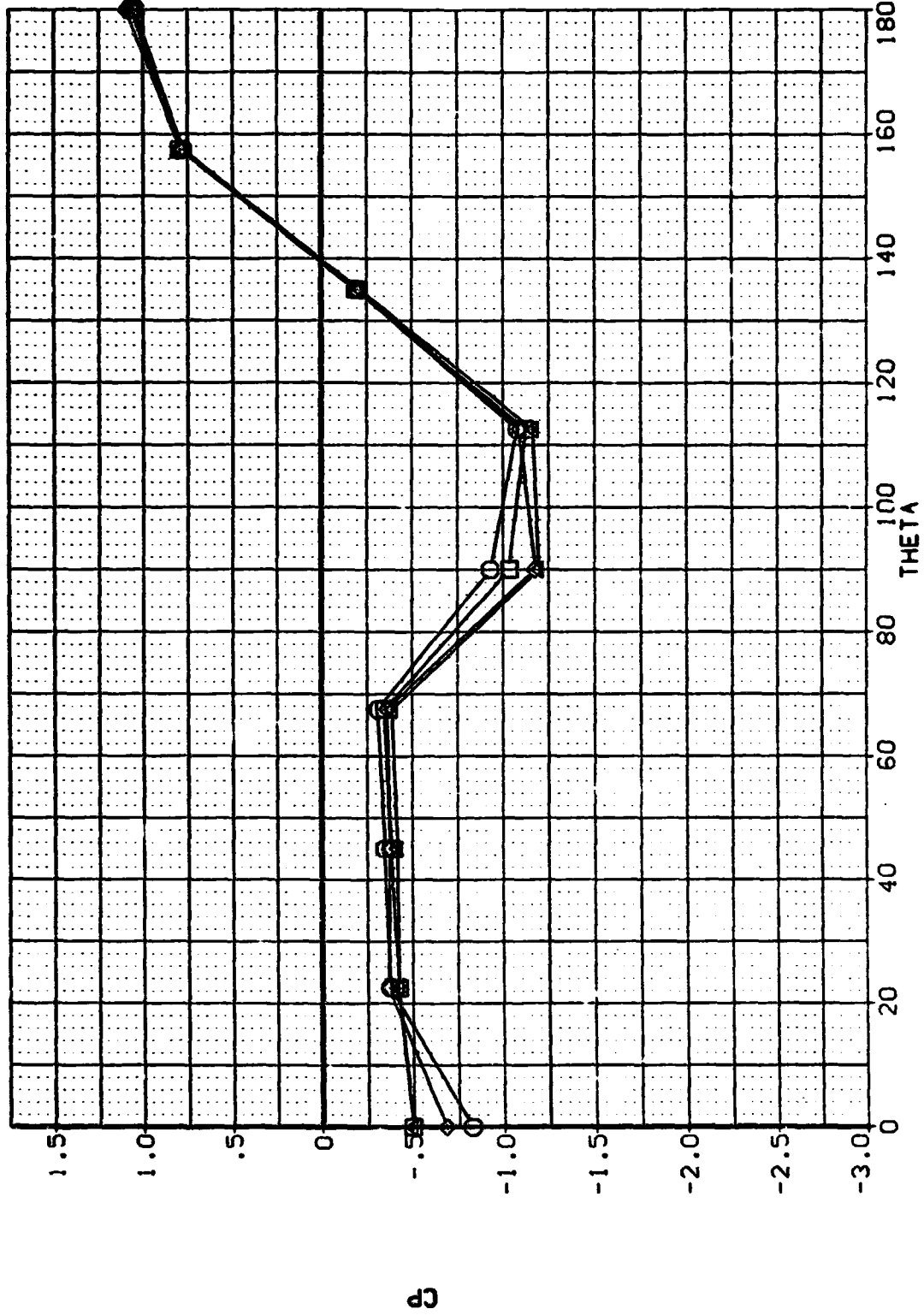

EFFECT OF REYNOLDS NUMBER ON PRESSURE COEFFICIENTS AT VARIOUS BODY STATIONS

MSFC HRWT 033 (SA29F) SRB FORWARD NOSE SECTION (R1E105)

SYMBOL	RN	X/D	ALPHA	BETA	PHI
○	13.383	1.810	270.000	MACH	.000
□	18.800				.400

PARAMETRIC VALUES
180.000

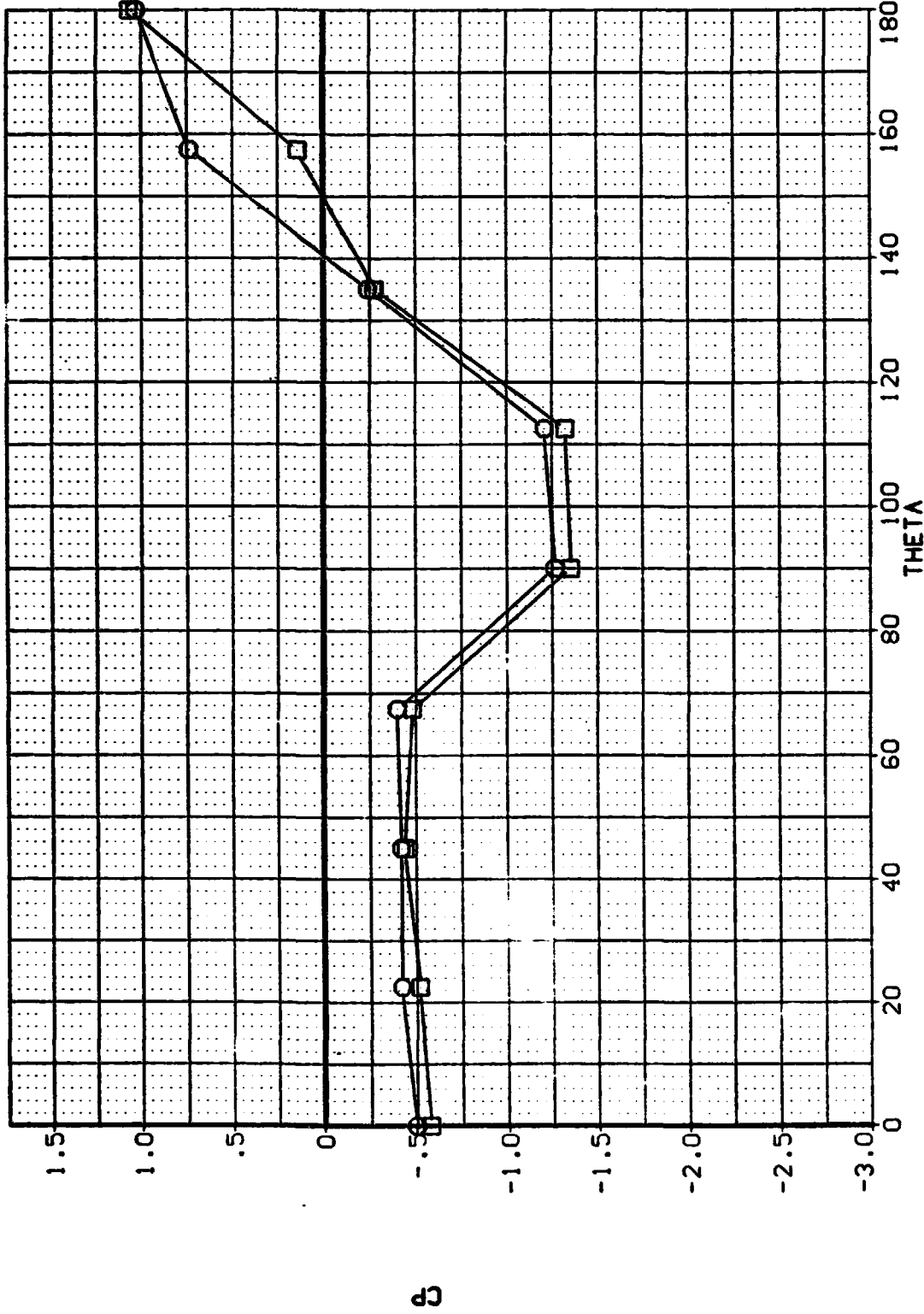

EFFECT OF REYNOLDS NUMBER ON PRESSURE COEFFICIENTS AT VARIOUS BODY STATIONS

MSFC HRWT 033 (SA29F) SRB FORWARD NOSE SECTION (RIE105)

SYMBOL	FN	X/D	ALPHA	BETA	PHI
○	4.017	2.160	270.000	MACH	.000
□	6.067				.400
◇	7.517				180.000
△	9.017				

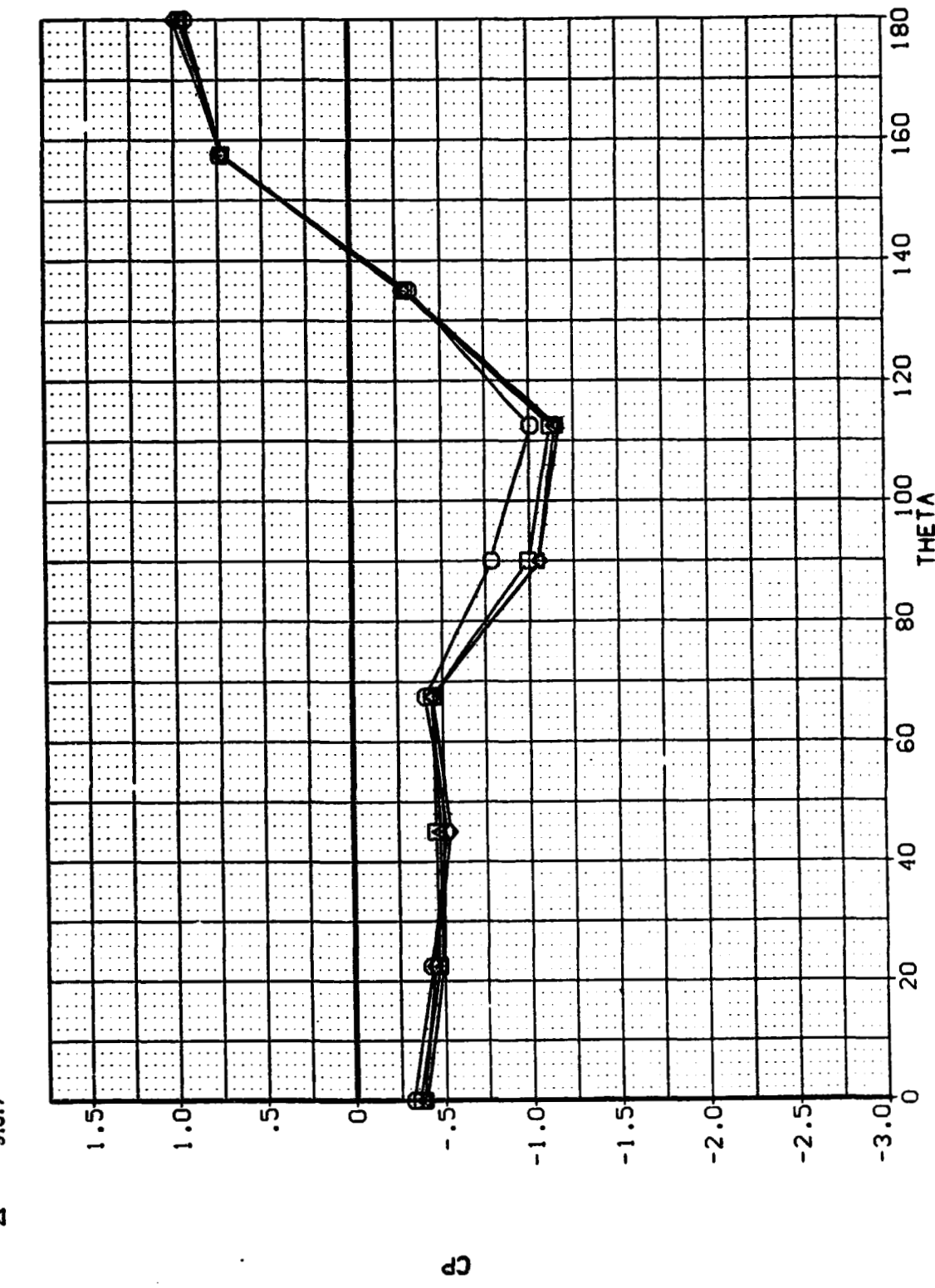

EFFECT OF REYNOLDS NUMBER ON PRESSURE COEFFICIENTS AT VARIOUS BODY STATIONS

MSFC HRWT 033 (SA29°) SRB FORWARD NOSE SECTION (R1E105)

SYMBOL	RN	X/D	ALPHA	PARAMETRIC VALUES	
○	13,363	2.160	270.000	BETA	PHI
□	18,800			MACH	
					180.000

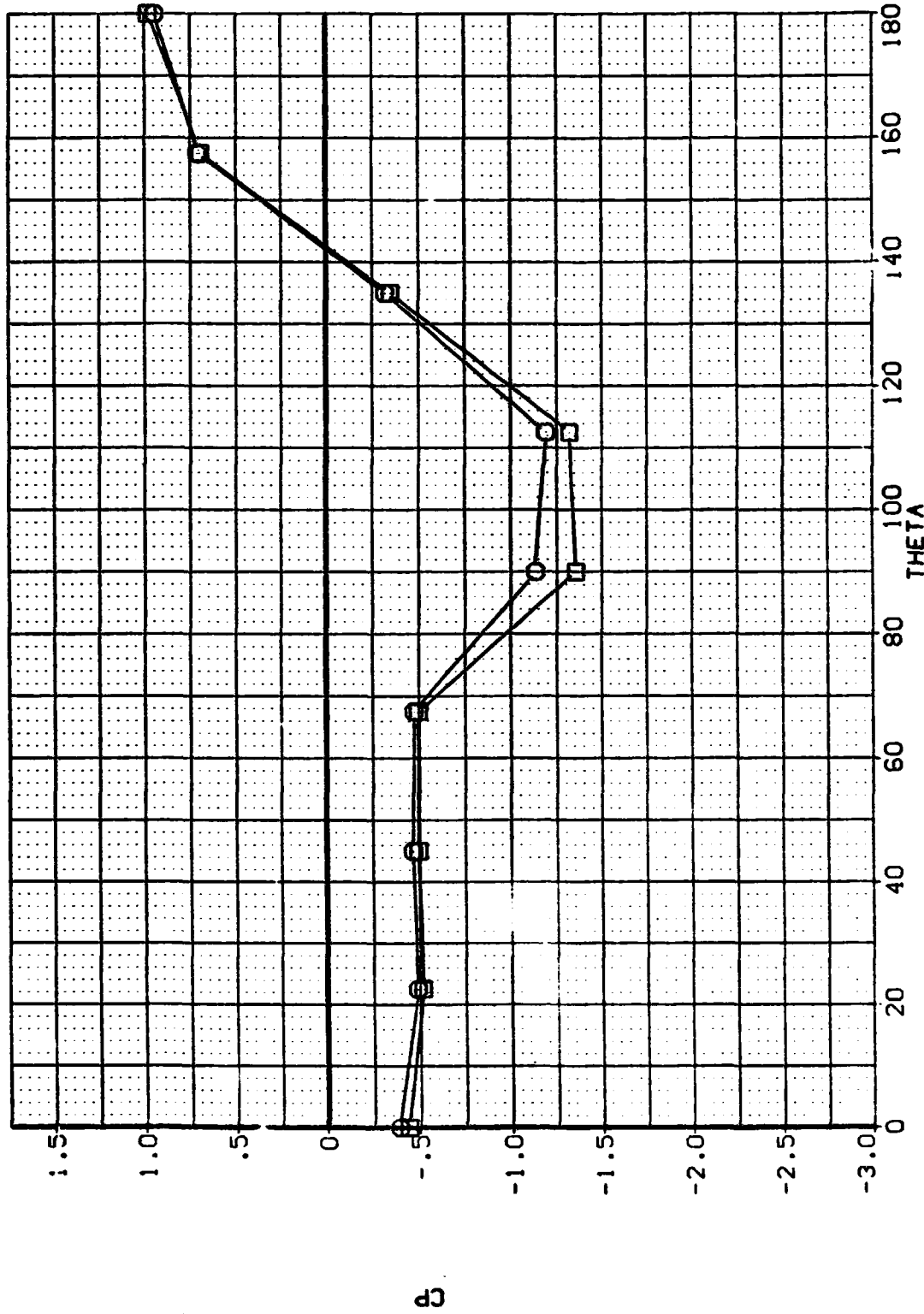

EFFECT OF REYNOLDS NUMBER ON PRESSURE COEFFICIENTS AT VARIOUS BODY STATIONS

MSFC HRWT 033 (SA29F) SRB FORWARD NOSE SECTION (B1E106)

SYMBOL	RM	X/D	ALPHA	BETA	PHI
○	2.767	1.810	270.000	KACH	.000
□	4.050				.600
△	5.650				1.800
◇	7.17				

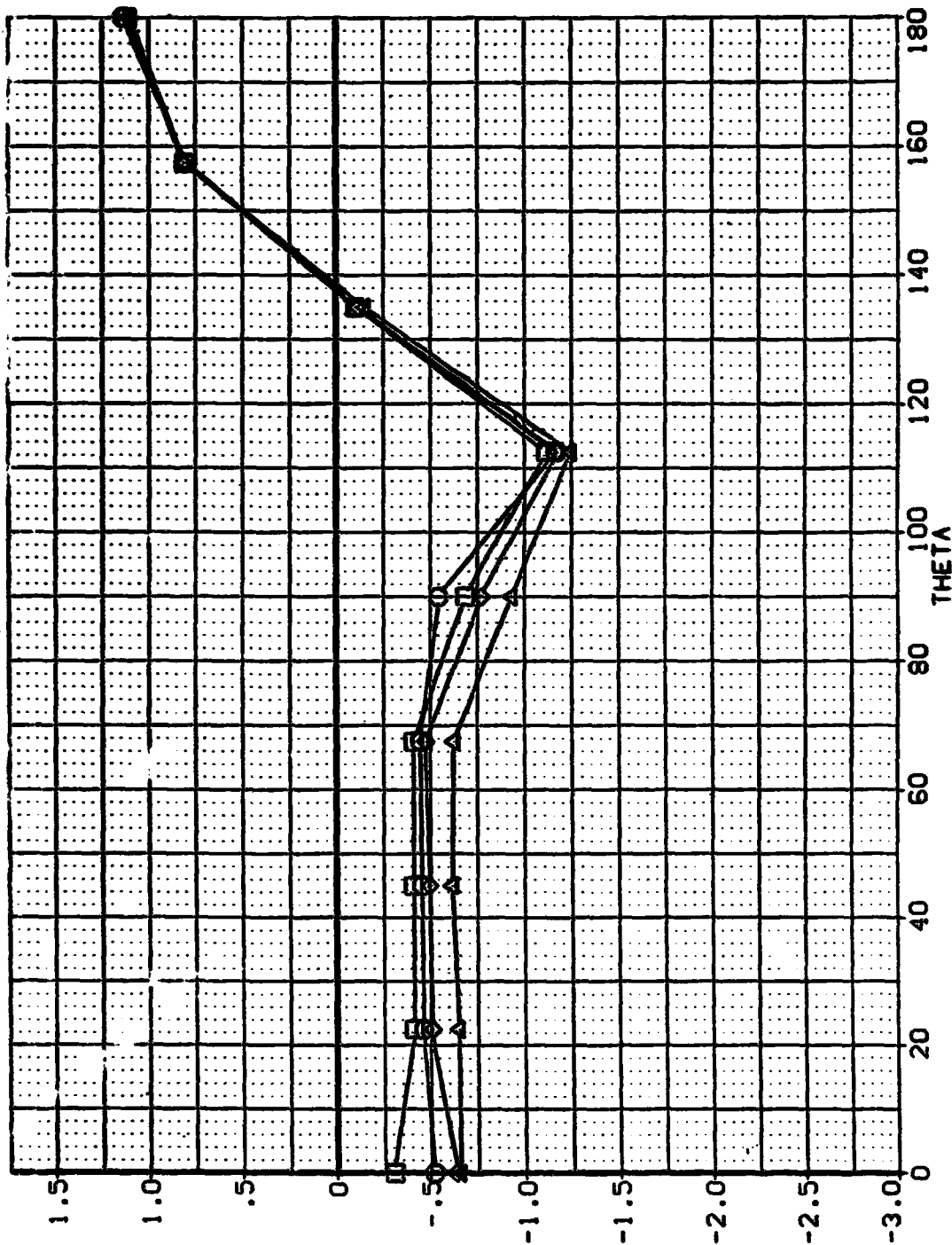

EFFECT OF REYNOLDS NUMBER ON PRESSURE COEFFICIENTS AT VARIOUS BODY STATIONS

MSFC HRWT 033 (SA29F) SRB FORWARD NOSE SECTION (B1E106)

SYMBOL	RM	X/D	ALPHA	BETA	PHI
□	8.717	1.810	270.000	MACH	.600
○	9.687				180.000
◇	12.750				
△	13.167				

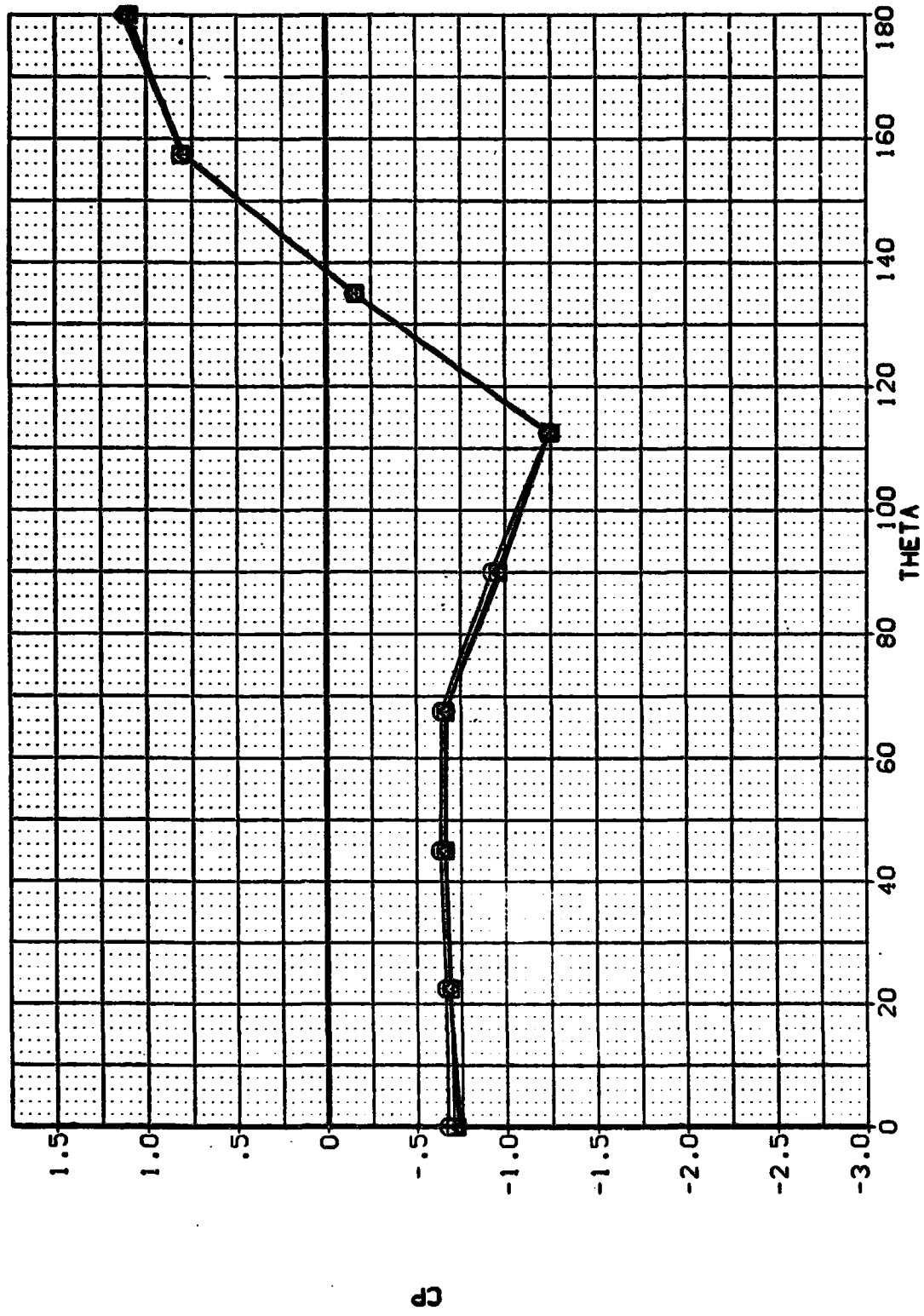

EFFECT OF REYNOLDS NUMBER ON PRESSURE COEFFICIENTS AT VARIOUS BODY STATIONS

MSFC HRWT 033 (SA29F) SRB FORWARD NOSE SECTION (B1E106)

SYMBOL RN X/O ALPHA BETA MACH .000 PHI 180.000
 ○ 16.083 1.810 270.000
 □ 20.050

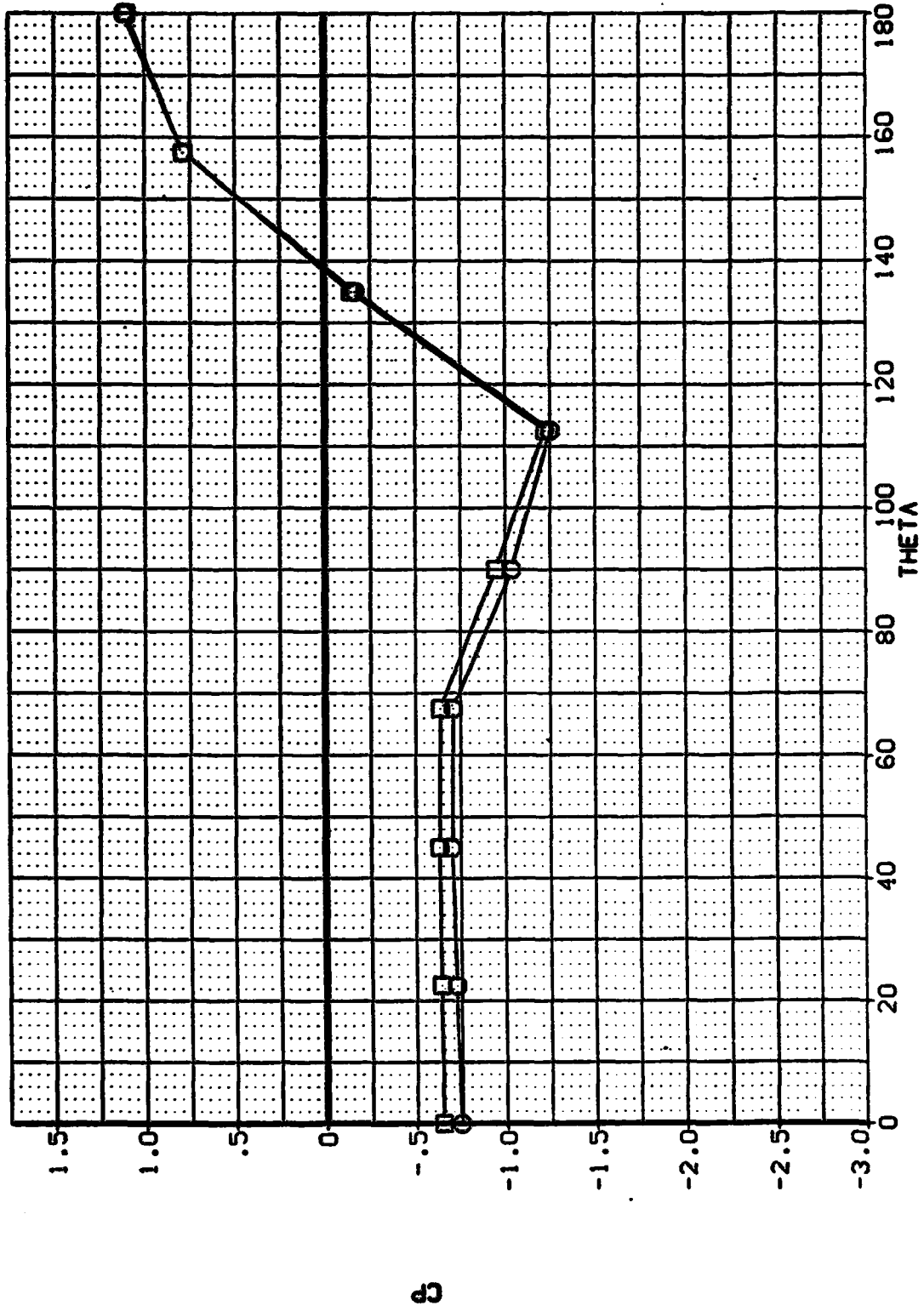

EFFECT OF REYNOLDS NUMBER ON PRESSURE COEFFICIENTS AT VARIOUS BODY STATIONS

MSFC HRWT 033 (SA29F) SRB FORWARD NOSE SECTION (B1E106)

SYMBOL	REYN	X/D	ALPHA	BETA	PARAMETRIC VALUES
□	2.767	2.160	270 °	MACH	.800
○	4.080				.600
◇	5.850				180.000
△	7.417				

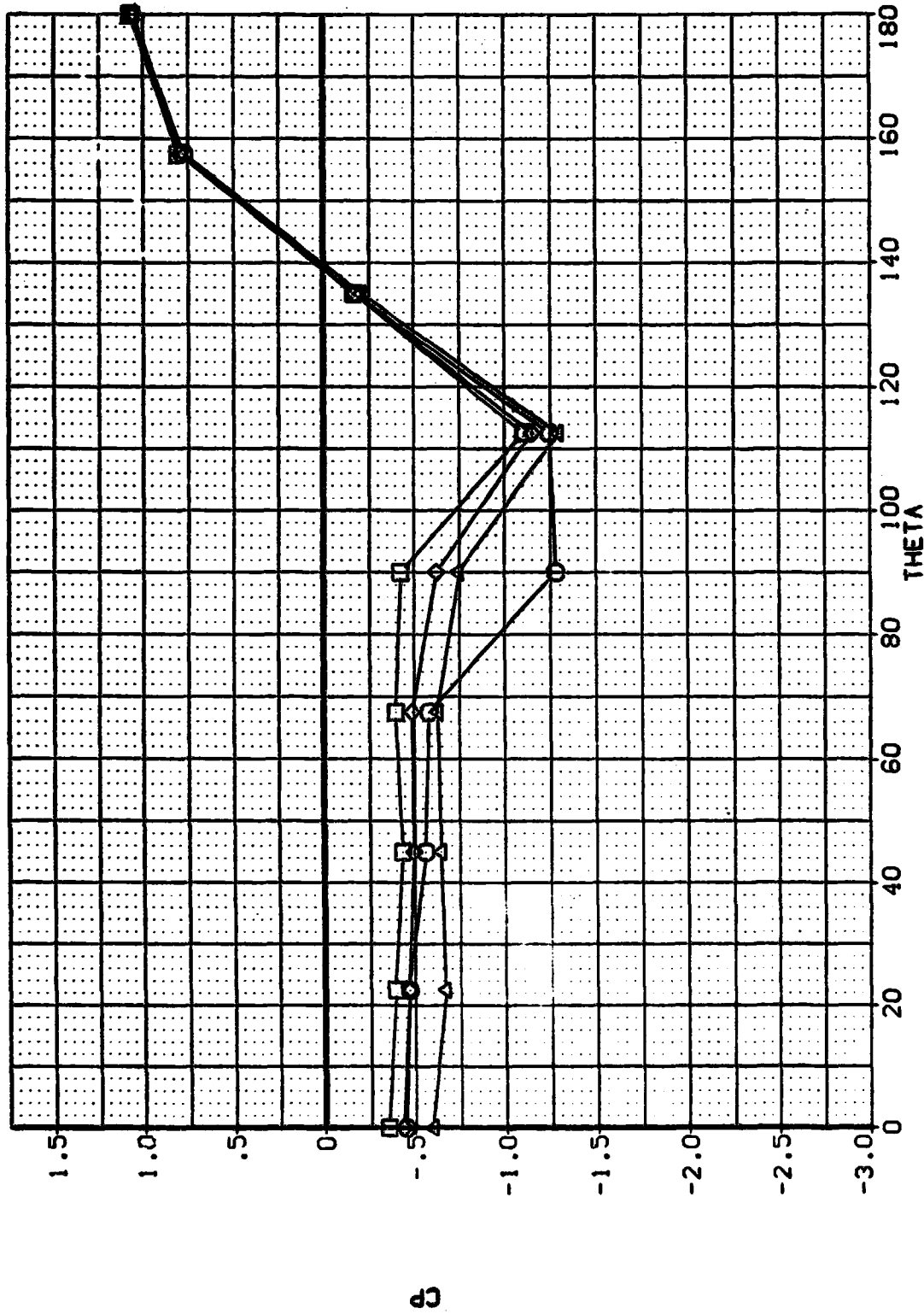

EFFECT OF REYNOLDS NUMBER ON PRESSURE COEFFICIENTS AT VARIOUS BODY STATIONS

MSFC HRWT 033 (SA29F) SRB FORWARD NOSE SECTION (B1E106)

SYMBOL	FN	X/O	ALPHA	BETA	PARAMETRIC VALUES
□	8.717	2.160	270.000	MACH	.000 PHI 180.000
◇	9.667				.600
△	12.750				
	13.167				

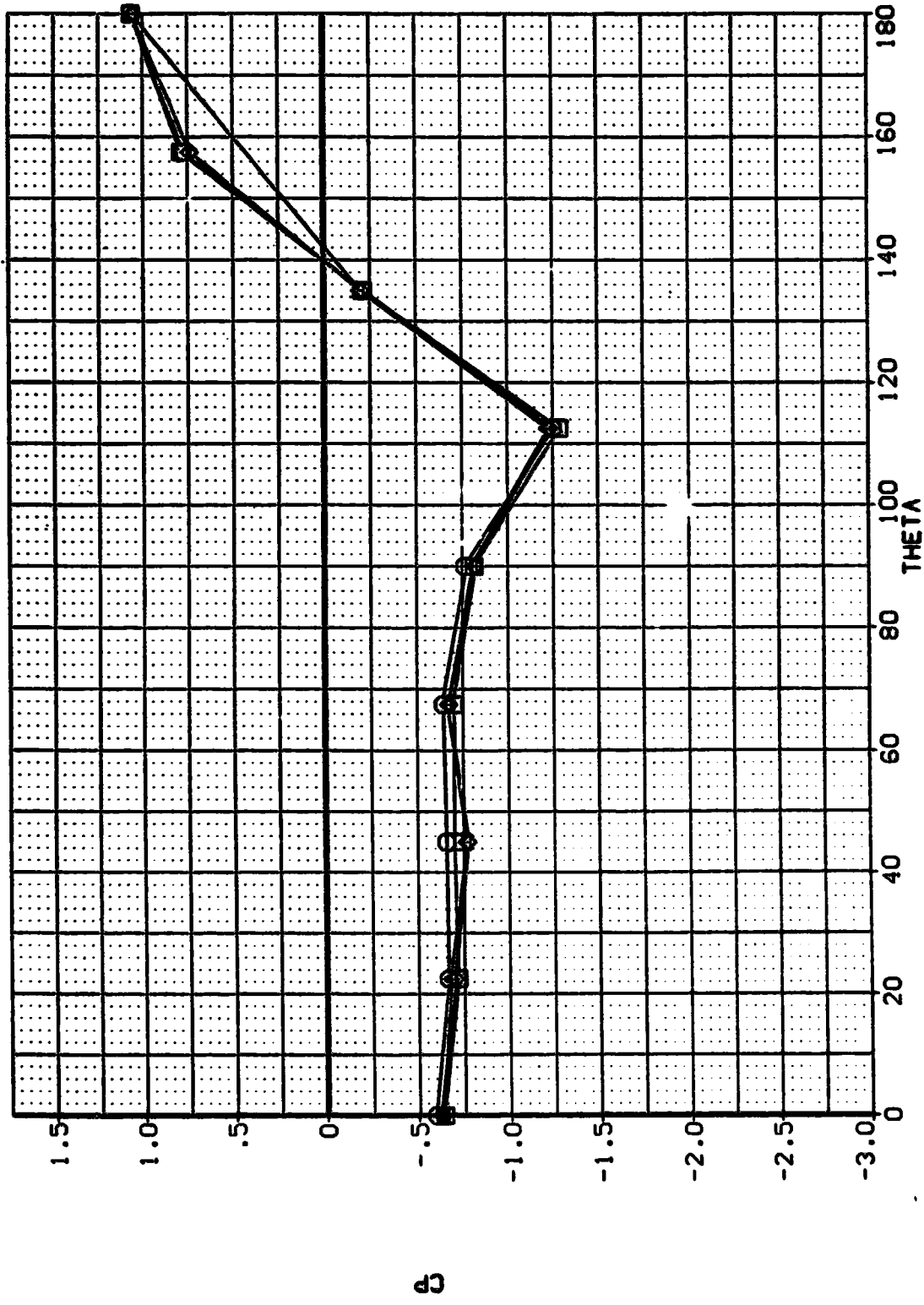

EFFECT OF REYNOLDS NUMBER ON PRESSURE COEFFICIENTS AT VARIOUS BODY STATIONS

MSFC HRWT 033 (SA29F) SRB FORWARD NOSE SECTION (B1E106)

SYMBOL	FN	X/D	ALPHA	BETA	PARAMETRIC VALUES
□	16.083	2.160	270.000	MACH	.000 PHI 180.000
□	20.050				.600

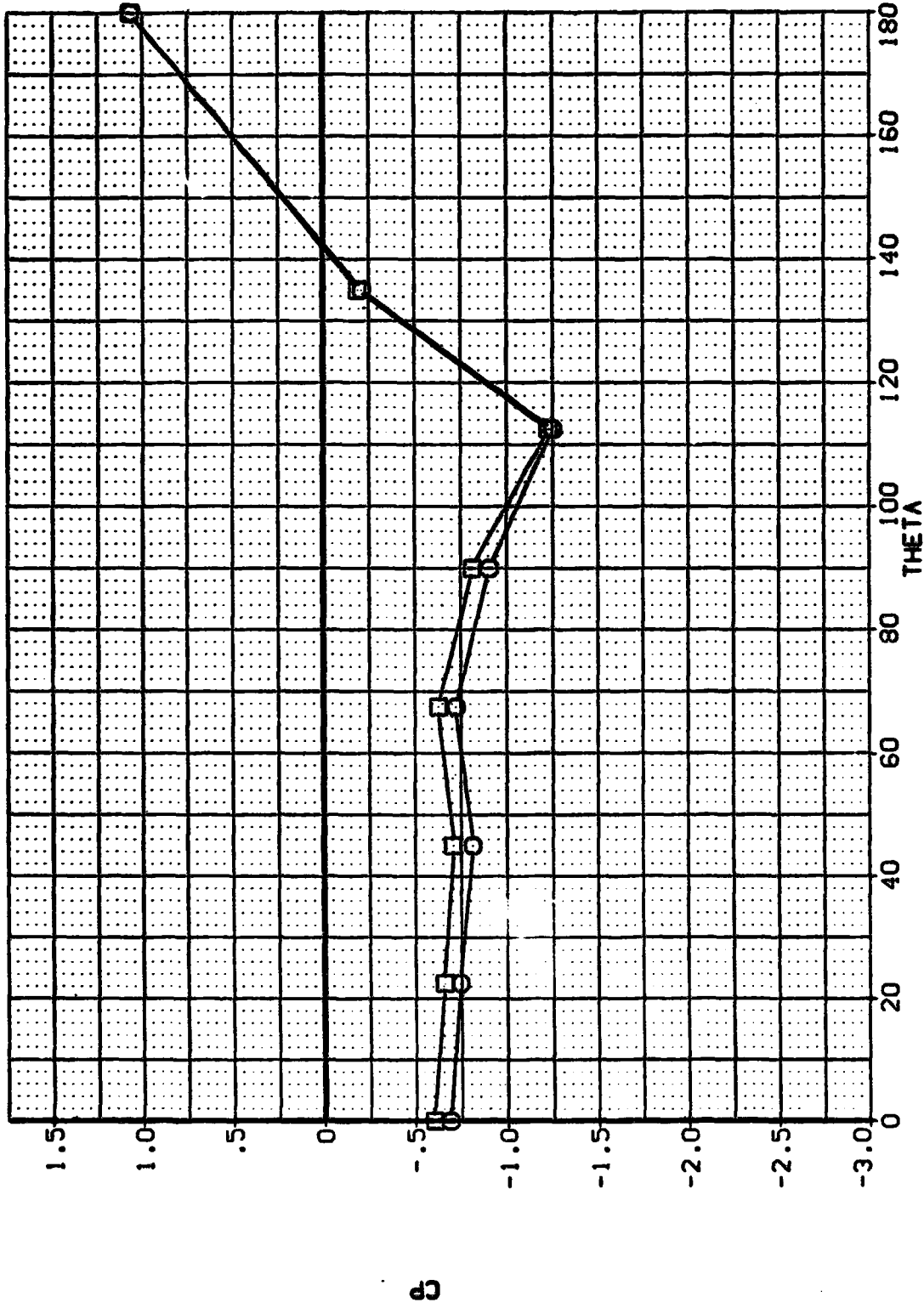

EFFECT OF REYNOLDS NUMBER ON PRESSURE COEFFICIENTS AT VARIOUS BODY STATIONS

APPENDIX
TABULATED SOURCE DATA

DATE 19 FEB 76

TABULATED SOURCE DATA, MSFC HRMT 033 (SA29F)

PAGE 1

MSFC HRMT 033 (SA29F) SRB FORWARD NOSE SECTION

(R1E101) (15 DEC 75)

REFERENCE DATA

SREF = 116.2600 SQ.FT. XMRP = 1044.0000 IN. XS
LREF = 146.0000 IN. YMRP = .0000 IN. YS
BREF = 146.0000 IN. ZMRP = .0000 IN. ZS
SCALE = .0137

PARAMETRIC DATA

BETA = .000 PHI = .000
RN = 18.100

MACH (1) = .410 ALPHA (1) = 72.100 Q(P1) = 61.000 TO = 47.667 RN = 18.517 PO = 590.45

SECTION (1) SRB NOSE DEPENDENT VARIABLE CP

X/D	.3400	.6750	1.0070	1.2850	1.3770	1.5500	1.8100	2.1600
THETA								
.000	-.3160	-.4600	-.1690	-.4140	-.7830	-.2960	-.3180	-.3690
22.500	-1.5360	-1.1870	-.9510	-.9010	-.6090	-.7140	-.7000	-.7000
45.000	-1.4720	-1.1590	-.8930	-.6210	-.6730	-.5370	-.7830	-.6200
67.500	-1.9710	-1.4140	-.9320	-.6590	-.8560	-.9080	-.6310	-.5750
90.000	-2.8050	-2.2320	-2.0130	-1.6340	-1.7280	-1.7700	-1.6450	-1.5350
112.500	-1.8760	-1.7050	-1.5840	-1.3050	-1.3210	-1.3990	-1.4650	-1.4060
135.000	-.5510	-.4380	-.5610	-.2830	-.2770	-.3410	-.4770	-.3430
157.500	.6020	.4060	.3940	.6580	.6370	.2590	.5680	.5680
180.000	.9390	.9750	1.0130	1.0270	1.0270	.9500	.9270	.9160

MACH (2) = .400 ALPHA (2) = 90.000 Q(P2) = 61.000 TO = 47.667 RN = 18.517 PO = 590.45

SECTION (1) SRB NOSE DEPENDENT VARIABLE CP

X/D	.3400	.6750	1.0070	1.2850	1.3770	1.5500	1.8100	2.1600
THETA								
.000	-.6620	-.5720	-.4790	-.5210	-.4770	-.5130	-.4880	-.5540
22.500	-.6430	-.5540	-.5540	-.6070	-.4830	-.5290	-.6030	-.5800
45.000	-.6440	-.5390	-.6650	-.5410	-.5390	-.5660	-.5190	-.5570
67.500	-.5620	-.5390	-.6040	-.4510	-.4560	-.5190	-.5390	-.5580
90.000	-.8940	-1.0240	-1.1080	-1.2690	-1.3140	-1.3370	-1.3440	-1.3370
112.500	-1.3220	-1.4090	-1.4380	-1.2590	-1.2720	-1.3500	-.4760	-1.4370
135.000	-.5980	-.5930	-.5920	-.4000	-.3360	-.3630	-.3980	-.3780
157.500	.3620	.3620	.2490	.4780	.5810	.6120	.6160	.6450
180.000	.6690	.7360	.8200	.8940	.9660	.9620	1.0090	.9870

ORIGINAL PAGE IS
OF POOR QUALITY

MSFC HRMT 033 (SA29F) SRB FORWARD NOSE SECTION (RIE101)

MACH (1) = .410 ALPHA (3) = 107.900 Q(PSI) = 61.000 TO = 47.667 RN = 18.517 PO = 560.45

SECTION (1) SRB NOSE DEPENDENT VARIABLE CP

X/D	.3400	.6750	1.0070	1.2850	1.3770	1.5500	1.8100	2.1600
THETA								
.000	-.5780	-.5480	-.4390	-.4980	-.5010	-.1070	-.4420	-.4410
22.500	-.5100	-.4480	-.4650	-.4650	-.4280	-.5200	-.5450	-.5450
45.000	-.5730	-.4530	-.6890	-.4180	-.4700	-.4310	-.4220	-.7010
67.500	-.5490	-.4950	-.4260	-.4070	-.3570	-.3930	-.4450	-.5290
90.000	-.8250	-.6550	-.2920	-.9790	-.10120	-.9020	-.11440	-.13150
112.500	-.12680	-.12490	-.13060	-.9190	-.11110	-.9650	-.9370	-.12810
135.000	-.16270	-.7500	-.16420	-.4200	-.3720	-.4140	-.3030	-.3820
157.500	.1310	.1710	.2320	.3650	.5110	.0410	.6170	.6170
180.000	.3060	.4020	.4900	.3970	.6920	.7660	.8980	.8570

MACH (2) = .600 ALPHA (1) = 72.100 Q(PSI) = 82.293 TO = 49.333 RN = 18.517 PO = 411.36

SECTION (1) SRB NOSE DEPENDENT VARIABLE CP

X/D	.3400	.6750	1.0070	1.2850	1.3770	1.5500	1.8100	2.1600
THETA								
.000	-1.0260	-.7520	-.5940	-.6490	-.6740	-.6010	-.4980	-.4200
22.500	-1.2500	-.8830	-.8830	-.7410	-.6440	-.6450	-.5180	-.4680
45.000	-1.6290	-1.1210	-.8120	-.6180	-.6020	-.5760	-.5030	-.4870
67.500	-1.5630	-1.0160	-.7510	-.6020	-.6000	-.5660	-.5120	-.4600
90.000	-1.8580	-1.3020	-1.0620	-1.1900	-1.1790	-1.0480	-.8610	-.7370
112.500	-1.2720	-1.2370	-1.1730	-1.0040	-1.0150	-1.0850	-1.1480	-1.1920
135.000	-.1670	-.1620	-.1300	-.0270	-.0270	-.0910	-.1420	-.1520
157.500	.7270	.7550	.8130	.7960	.7640	.7420	.7070	.7070
180.000	.9890	1.0330	1.0860	1.1060	1.0890	1.0360	1.0310	.9930

MACH (2) = .600 ALPHA (2) = 90.000 Q(PSI) = 82.293 TO = 49.333 RN = 18.517 PO = 411.36

SECTION (1) SRB NOSE DEPENDENT VARIABLE CP

X/D	.3400	.6750	1.0070	1.2850	1.3770	1.5500	1.8100	2.1600
THETA								
.000	-.6480	-.7010	-.5810	-.6730	-.6810	-.7020	-.6290	-.5480
22.500	-.7340	-.7280	-.6030	-.7260	-.6970	-.7160	-.6080	-.5970
45.000	-.7700	-.6800	-.8030	-.6900	-.7070	-.7090	-.5910	-.5980
67.500	-.6140	-.6510	-.8370	-.5890	-.6560	-.6830	-.5930	-.5840
90.000	-.8950	-.8410	-.9600	-1.0400	-1.1090	-.9140	-.8200	-.8980
112.500	-1.3940	-1.3540	-1.3530	-1.1640	-1.1400	-1.1870	-1.2500	-1.2730
135.000	-.4000	-.3930	-.3620	-.2120	-.1470	-.1570	-.1880	-.1990
157.500	.4570	.5240	.6310	.6360	.7330	.7710	.7490	.7490
180.000	.6910	.7760	.8540	.9170	1.0140	1.0300	1.0630	1.0610

MACH (2) = .610 ALPHA (3) = 107.900 Q(PS1) = 82.293 TO = 49.333 RW = 18.517 PO = 411.38 (RIE101)

SECTION (1) SRB NOSE DEPENDENT VARIABLE CP

X/D	.3400	.6750	1.0070	1.2850	1.3770	1.5500	1.8100	2.1600
THETA								
.000	-.7480	-.7120	-.6760	-.6760	-.6520	-.5970	-.6710	-.7080
22.500	-.7290	-.6790	-.6910	-.6040	-.6320	-.7140	-.7650	-.7650
45.000	-.7670	-.6870	-.6710	-.6360	-.6240	-.6970	-.7420	-.7420
67.500	-.6840	-.6430	-.6560	-.5700	-.5620	-.6880	-.7070	-.7070
90.000	-.7620	-.7150	-.7010	-.7850	-.9290	-.7130	-.0930	-.8760
112.500	-.1.3320	-.1.3330	-.1.4260	-.1.2410	-.1.1540	-.1.0700	-.1.2370	-.1.2380
135.000	-.6080	-.6580	-.5500	-.4410	-.3240	-.3310	-.2350	-.2530
157.500	.1350	.2170	.2840	.4380	.5670	.6330	.6310	.6310
180.000	.2990	.4060	.5120	.4780	.7320	.8310	.9310	.9220

MACH (3) = .760 ALPHA (1) = 72.100 Q(PS1) = 96.323 TO = 43.333 RW = 18.517 PO = 345.35

SECTION (1) SRB NOSE DEPENDENT VARIABLE CP

X/D	.3400	.6750	1.0070	1.2850	1.3770	1.5500	1.8100	2.1600
THETA								
.000	-.8030	-.7910	-.6940	-.6800	-.6620	-.5970	-.5450	-.5130
22.500	-.7870	-.7340	-.6890	-.6890	-.6650	-.5510	-.5910	-.5470
45.000	-.7860	-.7230	-.8200	-.6490	-.6860	-.6040	-.6390	-.5210
67.500	-.7460	-.7080	-.8830	-.5640	-.7540	-.5600	-.8230	-.4800
90.000	-.8530	-.8260	-.8850	-.7260	-.9080	-.6060	-.8120	-.5340
112.500	-.8270	-.8280	-.8040	-.6880	-.6900	-.7690	-.8490	-.8870
135.000	.1220	.1170	.1110	.1770	.1840	.1310	.0940	.0730
157.500	.8180	.8680	.9110	.8930	.8660	.8420	.8130	.8130
180.000	1.0500	1.1020	1.1430	1.1610	1.1460	1.1020	1.0990	1.0620

MACH (3) = .760 ALPHA (2) = 90.000 Q(PS1) = 96.323 TO = 43.333 RW = 18.517 PO = 345.35

SECTION (1) SRB NOSE DEPENDENT VARIABLE CP

X/D	.3400	.6750	1.0070	1.2850	1.3770	1.5500	1.8100	2.1600
THETA								
.000	-.6800	-.7830	-.6620	-.6620	-.7760	-.7110	-.6380	-.6400
22.500	-.7870	-.6540	-.6690	-.6690	-.7700	-.7650	-.6940	-.6700
45.000	-.8210	-.7360	-.8320	-.6160	-.7480	-.7520	-.6520	-.6480
67.500	-.7050	-.7090	-.8960	-.5340	-.6790	-.6960	-.7810	-.6460
90.000	-.8300	-.6900	-.9050	-.5290	-.6830	-.6740	-.8160	-.6440
112.500	-.1.0530	-.1.0200	-.9280	-.7990	-.8060	-.7490	-.8730	-.8770
135.000	-.1240	-.1140	-.0690	-.0580	-.0850	-.0890	-.0920	-.0840
157.500	.5680	.6550	.7480	.8010	.8470	.8880	.8770	.8770
180.000	.7220	.8310	.9250	.9850	1.0740	1.1030	1.1380	1.1370

MSFC HWMT 033 (SABSF) SRB FORWARD NOSE SECTION (RIE101)

MACH (3) = .760 ALPHA (3) = 107.600 Q(P31) = 66.323 TO = 43.333 RW = 16.917 PO = 348.36

SECTION (1) SRB NOSE

DEPENDENT VARIABLE CP

X/D	.750	1.0070	1.2650	1.37.0	1.5500	1.8100	2.1600
THETA							
.000	-.8480	-.8690	-.8050	-.7600	-.8000	-.7310	-.7210
22.500	-.8530	-.7960	-.7570	-.7190	-.7300	-.7210	-.7440
45.000	-.8890	-.7930	-.7360	-.7470	-.7360	-.7020	-.7350
67.500	-.7570	-.7470	-.7000	-.6530	-.6670	-.6990	-.7040
90.000	-.8930	-.7420	-.6910	-.6660	-.7480	-.6650	-.7320
112.500	-1.1140	-1.1050	-1.1740	-1.0260	-1.0120	-.9770	-.9450
135.000	-.4480	-.4440	-.3640	-.2660	-.1760	-.0300	-.0260
157.500	.1930	.2640	.3140	.4900	.6260	.7060	.7270
180.000	.3110	.4270	.5140	.4870	.7530	.6730	.9790

DATE 19 FEB 76

TABLATED SOURCE DATA, MSFC HRMT 033 (SABGF)

PAGE 5

MSFC HRMT 033 (SABGF) SRB FORWARD NOSE SECTION

(RIE102) (19 DEC 75)

REFERENCE DATA

SREF = 116.2600 SQ.FT. XMRP = 1044.0000 IN. XS
LREF = 146.0000 IN. YMRP = .0000 IN. YS
BREF = 146.0000 IN. ZMRP = .0000 IN. ZS
SCALE = .0137

PARAMETRIC DATA

BETA = .000 PHI = .000
RN = 18.100

MACH (1) = .500 ALPHA (1) = 72.000 Q(P51) = 75.080 T0 = 49.200 RN = 18.757 PO = 506.68

SECTION (1) SRB NOSE DEPENDENT VARIABLE CP

X/D	.3400	.6750	1.0070	1.2850
THETA				
.000	-.5160	-.4820	-.3300	-.4380
22.500	-1.3410	-.8230	-.6640	
45.000	-1.7690	-1.1490	-.7190	-.4960
67.500	-1.6930	-1.1470	-.6570	-.4320
90.000	-2.4020	-2.0230	-1.5080	-1.3800
112.500	-1.6110	-1.5810	-1.1240	-1.0230
135.000	-.3970	-.3380	-.2330	-.0970
157.500		.6870	.6910	.7210
180.000	.9540	.9910	1.0540	1.0430

MACH (1) = .510 ALPHA (2) = 80.000 Q(P51) = 75.080 T0 = 49.200 RN = 18.757 PO = 506.68

SECTION (1) SRB NOSE DEPENDENT VARIABLE CP

X/D	.3400	.6750	1.0070	1.2850
THETA				
.000	-.8350	-.5910	-.5030	-.5140
22.500	-1.1250	-.7530	-.6030	
45.000	-1.6030	-1.0340	-.6590	-.4870
67.500	-1.4440	-.9330	-.6270	-.4350
90.000	-1.9270	-1.5610	-1.2710	-1.2030
112.500	-1.6990	-1.6200	-1.1560	-1.0300
135.000	-.4960	-.4310	-.3090	-.1060
157.500		.6100	.6250	.6990
180.000	.8590	.9250	1.0030	1.0200

ORIGINAL PAGE IS
OF POOR QUALITY

MSFC HRMT 033 (SA29F) SRB FORWARD NOSE SECTION (RIE102)

MACH (1) = .490 ALPHA (3) = 90.000 Q(PSI) = 75.080 TO = 49.200 RN = 18.757 PO = 506.66

SECTION (1) SRB NOSE DEPENDENT VARIABLE CP

X/D .3400 .6750 1.0070 1.2850

THETA	CP
.000	-.5920
.000	-.5460
.000	-.5410
.000	-.5000
.000	-.5720
.000	-.5640
.000	-.4750
.000	-.5240
.000	-.6360
.000	-.4090
.000	-.5410
.000	-.1690
.000	-.1.3350
.000	-.1.3670
.000	-.1.1320
.000	-.1.1040
.000	-.5060
.000	-.4810
.000	-.4180
.000	-.2440
.000	.4810
.000	.5780
.000	.7040
.000	.7900
.000	.6690
.000	.9110

MACH (1) = .500 ALPHA (4) = 100.000 Q(PSI) = 75.080 TO = 49.200 RN = 18.757 PO = 506.66

SECTION (1) SRB NOSE DEPENDENT VARIABLE CP

X/D .3400 .6750 1.0070 1.2850

THETA	CP
.000	-.4740
.000	-.4590
.000	-.4560
.000	-.4900
.000	-.4520
.000	-.4140
.000	-.4680
.000	-.3110
.000	-.4920
.000	-.5210
.000	-.4090
.000	-.5730
.000	-.5120
.000	-.3870
.000	-.6280
.000	-.7080
.000	-.8520
.000	-.1.0320
.000	-.1.2080
.000	-.1.2430
.000	-.1.3130
.000	-.1.1530
.000	-.4970
.000	-.5350
.000	-.4690
.000	-.2990
.000	.3060
.000	.3410
.000	.3830
.000	.4680
.000	.5920
.000	.6630
.000	.7070

MACH (1) = .500 ALPHA (5) = 108.000 Q(PSI) = 75.080 TO = 49.200 RN = 18.757 PO = 506.66

SECTION (1) SRB NOSE DEPENDENT VARIABLE CP

X/D .3400 .6750 1.0070 1.2850

THETA	CP
.000	-.4260
.000	-.4060
.000	-.4340
.000	-.4110
.000	-.3920
.000	-.4060
.000	-.3980
.000	-.2720
.000	-.4030
.000	-.4290
.000	-.3580
.000	-.3680
.000	-.3450
.000	-.6810
.000	-.3290
.000	-.6520
.000	-.5760
.000	-.8090
.000	-.6940
.000	-.1.1030
.000	-.1.1470
.000	-.1.4100
.000	-.1.1160
.000	-.1.5530
.000	-.5320
.000	-.5600
.000	-.4510
.000	.1970
.000	.2110
.000	.2530
.000	.3420
.000	.4630
.000	.4560
.000	.5180

MACH (2) = .600 ALPHA (1) = 80.000 O(PSI) = 82.715 TO = 48.000 RN = 18.757 PO = 414.82
 MSFC HRWT 033 (SA28F) SRB FORWARD NOSE SECTION (RIE108)

SECTION (1) SRB NOSE DEPENDENT VARIABLE CP

X/D	.3400	.6750	1.0070	1.2850
THETA				
.000	-.7820	-.6880	-.5610	-.4840
22.500	-.7250	-.6130	-.5400	-.5000
45.000	-.7340	-.6840	-.6420	-.5000
67.500	-.7300	-.6340	-.7540	-.4350
90.000	-.7400	-.8250	-.8460	-.10520
112.500	-1.2670	-1.2870	-.9760	-.9790
135.000	-.2730	-.2530	-.1680	-.0410
157.500	.6730	.6910	.7600	
180.000	.8900	.9820	1.0370	1.0540

MACH (2) = .600 ALPHA (2) = 100.000 O(PSI) = 82.715 TO = 48.000 RN = 18.757 PO = 414.82

SECTION (1) SRB NOSE DEPENDENT VARIABLE CP

X/D	.3400	.6750	1.0070	1.2850
THETA				
.000	-.8670	-.7590	-.6650	-.6750
22.500	-.7820	-.6580	-.7000	-.7000
45.000	-.6180	-.7600	-.7330	-.6720
67.500	-.8090	-.7320	-.7510	-.6140
90.000	-.9120	-.9040	-.7520	-.9510
112.500	-1.5050	-1.4430	-1.4050	-1.1940
135.000	-.5600	-.5600	-.4300	-.2730
157.500	.3140	.3690	.4290	
180.000	.4540	.6330	.6830	.7160

MACH (3) = .790 ALPHA (1) = 80.000 O(PSI) = 101.19 TO = 41.000 RN = 18.757 PO = 347.11

SECTION (1) SRB NOSE DEPENDENT VARIABLE CP

X/D	.3400	.6750	1.0070	1.2850
THETA				
.000	-.5920	-.5930	-.6120	-.5850
22.500	-.5990	-.6400	-.5900	-.5900
45.000	-.5820	-.5710	-.7190	-.5420
67.500	-.5550	-.5350	-.6260	-.4950
90.000	-.4600	-.5380	-.7600	-.5410
112.500	-.8530	-.8510	-.6550	-.6560
135.000	.0590	.0730	.1100	.1930
157.500	.7970	.8200	.8860	
180.000	.9520	1.0420	1.0970	1.1400

MSFC HRWT 033 (SAL97) SRB FORWARD NOSE SECTION (RIE102)

MACH (3) = .790 ALPHA (2) = 100.000 Q(P51) = 101.19 TO = 41.000 RN = 18.757 PO = 347.11

SECTION (1) SRB NOSE DEPENDENT VARIABLE CP

X/D .3400 .6750 1.0070 1.2850

THETA	CP
.000	-.8140
22.507	-.8100
45.000	-.8020
67.500	-.7770
90.000	-.7630
112.500	-.7670
135.000	-.7450
157.500	-.8660
180.000	-1.0940
	-1.0460
	-1.0310
	-.2370
	-.1720
	.4230
	.6940
	.5070
	.7290
	.7740
	-.7760
	-.7570
	-.7550
	-.6990
	-.6740
	-.9030
	-.0530
	.5340
	.7740

DATE 19 FEB 76

TABULATED SOURCE DATA, MSFC HRWT 033 (SA28F)

PAGE 9

MSFC HRWT 033 (SA28F) SRB FORWARD NOSE SECTION (RIE107) (15 DEC 75)

REFERENCE DATA

SREF = 116.2600 SQ.FT. XMRP = 1044.0000 IN. X5
LREF = 146.0000 IN. YMRP = .0000 IN. Y5
BREF = 146.0000 IN. ZMRP = .0000 IN. Z5
SCALE = .0137

PARAMETRIC DATA

BETA = .000 PHI = .000
RN = 9.000

MACH (1) = 2.000 ALPHA (1) = 72.000 Q(PS1) = 71.840 T0 = 59.600 RN = 9.0467 PO = 200.21

SECTION (1) SRB NOSE DEPENDENT VARIABLE CP

X/O	.3400	.6750	1.0070	1.2850
THETA				
.000	-.2520	-.2390	-.2280	-.2110
22.500	-.2460	-.2340	-.2270	-.2040
45.000	-.2580	-.2380	-.2270	-.1740
67.500	-.2520	-.2160	-.2040	-.1940
90.000	-.0500	-.0590	-.0780	-.0700
112.500	.3900	.3650	.3620	.3400
135.000	1.0200	.9820	.9350	.9200
157.500	1.4420	1.4490	1.4490	1.4580
180.000	1.6360	1.6410	1.6520	1.6710

MACH (1) = 2.000 ALPHA (2) = 80.000 Q(PS1) = 71.840 T0 = 59.600 RN = 9.0467 PO = 200.21

SECTION (1) SRB NOSE DEPENDENT VARIABLE CP

X/O	.3400	.6750	1.0070	1.2850
THETA				
.000	-.2830	-.2620	-.2640	-.2490
22.500	-.2760	-.2670	-.2670	-.2490
45.000	-.2890	-.2660	-.2640	-.2260
67.500	-.2710	-.2380	-.2670	-.2310
90.000	-.0920	-.0960	-.1070	-.0740
112.500	.3180	.3020	.3080	.3360
135.000	.9330	.9180	.9000	.9150
157.500	1.2680	1.4190	1.4190	1.4600
180.000	1.5070	1.5710	1.6330	1.6760

ORIGINAL PAGE IS OF POOR QUALITY

MSFC HRMT 033 (SA28F) SRB FORWARD NOSE SECTION (RIE103)

MACH (1) = 2.000 ALPHA (3) = 90.000 Q(PSI) = 71.640 TO = 59.600 RN = 9.0467 FO = 200.21

SECTION (1) SRB NOSE DEPENDENT VARIABLE CP

X/D .3400 .6750 1.0070 1.2850

THETA	.000	-.2990	-.2940	-.2750	-.2670
22.500	-.2910	-.2810	-.2620		
45.000	-.3040	-.2870	-.2770	-.2260	
67.500	-.2920	-.2790	-.2780	-.2380	
90.000	-.1470	-.1390	-.1350	-.1000	
112.500	.2200	.2060	.2390	.2830	
135.000	.7800	.8070	.7880	.8310	
157.500	1.2000	1.2610	1.3150		
180.000	1.3280	1.3970	1.4620	1.5190	

MACH (1) = 2.000 ALPHA (4) = 100.000 Q(PSI) = 71.640 TO = 59.600 RN = 9.0467 FO = 200.21

SECTION (1) SRB NOSE DEPENDENT VARIABLE CP

X/D .3400 .6750 1.0070 1.2850

THETA	.000	-.2840	-.2770	-.2810	-.2660
22.500	-.2750	-.2920	-.2580		
45.000	-.3020	-.2810	-.2140	-.2580	
67.500	-.2930	-.2140	-.2890	-.2240	
90.000	-.1930	-.1740	-.1700	-.1500	
112.500	.1130	.1170	.1390	.1690	
135.000	.5770	.5970	.6170	.6740	
157.500	1.0140	1.0680	1.0790		
180.000	1.0910	1.1720	1.2280	1.2380	

MACH (1) = 2.000 ALPHA (5) = 108.000 Q(PSI) = 71.640 TO = 59.600 RN = 9.0467 FO = 200.21

SECTION (1) SRB NOSE DEPENDENT VARIABLE CP

X/D .3400 .6750 1.0070 1.2850

THETA	.000	-.2790	-.2710	-.2600	-.2320
22.500	-.2670	-.2890	-.2070		
45.000	-.2970	-.2770	-.2610	-.1490	
67.500	-.2910	-.1960	-.2850	-.1760	
90.000	-.2230	-.2000	-.1980	-.1940	
112.500	.0180	.0340	.0610	.0560	
135.000	.4190	.4380	.4780	.4380	
157.500	.8220	.8780	.8780	.7200	
180.000	.8690	.9520	1.0110	.8910	

MSFC HRWT 033 (SAB2F) SRB FORWARD NOSE SECTION (R1E104) (15 DEC 75)

REFERENCE DATA

SREF = 116.2600 SO.FT. XMRP = 1044.0000 IN. XS
 LREF = 146.0000 IN. YMRP = .0000 IN. YS
 BREF = 146.0000 IN. ZMRP = .0000 IN. ZS
 SCALE = .0137

MACH (1) = .420 ALPHA (1) = 28.210 Q(PSI) = 51.000 TO = 8.4000 PO = 263.12

PARAMETRIC DATA

BETA = .000 PHI = .000
 RN = 8.400

SECTION (1) SF:3 NOSE DEPENDENT VARIABLE CP

X/D	THETA
.3400	.6750
.000	-.3360
.000	-.4240
22.500	-1.5200
45.000	-1.1110
67.500	-1.4640
90.000	-1.9910
112.500	-1.2530
135.000	-2.7080
157.500	-2.0720
180.000	-1.7980
	-1.6390
	-.4200
	.6080
	.9530
	.9790

MSFC HRWT 033 (SA29F) SRB FORWARD NOSE SECTION (R1E105) (15 DEC 75)

REFERENCE DATA

SREF = 116.2600 SQ.FT. XMRP = 1044.0000 IN. XS
LREF = 146.0000 IN. YMRP = .0000 IN. YS
BREF = 146.0000 IN. ZMRP = .0000 IN. ZS
SCALE = .0137

RN (1) = 2.250 ALPHA (1) = 90.000 Q(PS1) = 7.2900 TO = 37.000 RN = 2.2500 PO = 67.600

SECTION (1) SRB NOSE DEPENDENT VARIABLE CP

X/D 1.8100 2.1600

THETA
.000
22.500
45.000
67.500
90.000
112.500
135.000
157.500
180.000

RN (2) = 4.017 ALPHA (1) = 270.000 Q(PS1) = 13.370 TO = 51.000 RN = 4.0167 PO = 128.12

SECTION (1) SRB NOSE DEPENDENT VARIABLE CP

X/D 1.8100 2.1600

THETA
.000
22.500
45.000
67.500
90.000
112.500
135.000
157.500
180.000

PARAMETRIC DATA

BETA = .000 PHI = 180.000
MACH = .400

MSFC HRNT 033 (SA29F) SRB FORWARD NOSE SECTION (R1E106)
 RN (3) = 6.067 ALPHA (1) = 270.000 Q(PS1) = 19.930 TO = 46.000 RN = 6.0667 PO = 191.41

SECTION (1) SRB NOSE DEPENDENT VARIABLE CP

X/D	1.8100	2.1600
THETA		
.000	-.4970	-.3640
22.500	-.4230	-.4710
45.000	-.3860	-.4620
67.500	-.3500	-.4470
90.000	-1.0390	-.9970
112.500	-1.1240	-1.1270
135.000	-.1930	-.3040
157.500	.7940	.7260
180.000	1.0570	.9570

RN (4) = 7.517 ALPHA (1) = 270.000 Q(PS1) = 25.360 TO = 49.000 RN = 7.5167 PO = 236.79

SECTION (1) SRB NOSE DEPENDENT VARIABLE CP

X/D	1.8100	2.1600
THETA		
.000	-.6830	-.3810
22.500	-.3710	-.4440
45.000	-.3770	-.5360
67.500	-.3590	-.4490
90.000	-1.1760	-1.0560
112.500	-1.0970	-1.1430
135.000	-.1880	-.2910
157.500	.7840	.7290
180.000	1.0930	.9920

RN (5) = 9.017 ALPHA (1) = 270.000 Q(PS1) = 30.220 TO = 49.000 RN = 9.0167 PO = 266.83

SECTION (1) SRB NOSE DEPENDENT VARIABLE CP

X/D	1.8100	2.1600
THETA		
.000	-.4970	-.3990
22.500	-.4270	-.4900
45.000	-.4190	-.4210
67.500	-.3890	-.4190
90.000	-1.1960	-1.0620
112.500	-1.1630	-1.1630
135.000	-.2150	-.3070
157.500	.7860	.7240
180.000	1.0400	.9510

MSFC HRMT 033 (S429F) SRB FORWARD NOSE SECTION (R1E105)

RN (6) = 10.217 ALPHA (1) = 90.000 Q(PSI) = 32.730 TO = 38.000 RN = 10.217 PO = 315.68

SECTION (1) SRB NOSE DEPENDENT VARIABLE CP

X/D 1.8100 2.1600

THETA	.000	-.5620	-.4110
22.500	-.4120	-.5210	
45.000	-.4410	-.6560	
67.500	-.4160	-.4710	
90.000	-1.2170	-1.0880	
112.500	-.8640	-1.2060	
135.000	-.2320	-.3320	
157.500	.7580	.7240	
180.000	1.0640	.9870	

RN (7) = 13.383 ALPHA (1) = 270.000 Q(PSI) = 44.620 TO = 48.000 RN = 13.383 PO = 424.20

SECTION (1) SRB NOSE DEPENDENT VARIABLE CP

X/D 1.8100 2.1600

THETA	.000	-.4980	-.3680
22.500	-.4220	-.4910	
45.000	-.4210	-.4700	
67.500	-.4000	-.4750	
90.000	-1.2630	-1.1380	
112.500	-1.2110	-1.1970	
135.000	-.2370	-.3190	
157.500	.7380	.7060	
180.000	1.0250	.9430	

RN (8) = 18.800 ALPHA (1) = 270.000 Q(PSI) = 61.330 TO = 44.000 RN = 18.800 PO = 560.08

SECTION (1) SRB NOSE DEPENDENT VARIABLE CP

X/D 1.8100 2.1600

THETA	.000	-.5780	-.4420
22.500	-.5150	-.5190	
45.000	-.4410	-.4950	
67.500	-.4810	-.5000	
90.000	-1.3490	-1.3620	
112.500	-1.3240	-1.3260	
135.000	-.2740	-.3500	
157.500	.1340	.6350	
180.000	1.0550	.9790	

DATE 19 FEB 76

TABULATED SOURCE DATA, MSFC HRNT 033 (SA29F)

PAGE 15

(R1E106) (15 DEC 75)

MSFC HRNT 033 (SA29F) SRB FORWARD NOSE SECTION

REFERENCE DATA

SREF = 116.2600 SO.FT. XMRP = 1044.0000 IN. XS
LREF = 146.0000 IN. YMRP = .0000 IN. YS
BREF = 146.0000 IN. ZMRP = .0000 IN. ZS
SCALE = .0137

PARAMETRIC DATA

BETA = .000 PHI = 180.000
MACH = .600

RN (1) = 2.767 ALPHA (1) = 270.000 Q(PF1) = 12.990 TO = 49.000 RN = 2.7667 PO = 64.300

SECTION: (1) SRB NOSE DEPENDENT VARIABLE CP

X/D 1.8100 2.1600

THETA
.000
22.500
45.000
67.500
90.000
112.500
135.000
157.500
180.000

RN (2) = 4.050 ALPHA (1) = 270.000 Q(PF1) = 19.680 TO = 41.000 RN = 4.0500 PO = 92.220

SECTION: (1) SRB NOSE DEPENDENT VARIABLE CP

X/D 1.8100 2.1600

THETA
.000
22.500
45.000
67.500
90.000
112.500
135.000
157.500
180.000

MSFC HRMT 033 (SA29F) SRB FORWARD NOSE SECTION (RIE106)

RN (3) = 5.850 ALPHA (1) = 270.000 Q(PS1) = 27.260 TO = 46.000 RN = 5.8500 PO = 136.57

SECTION (1) SRB NOSE DEPENDENT VARIABLE CP

X/D 1.8100 2.1600

THETA

.000 - .6340 - .4350
22.500 - .5110 - .4700
45.000 - .4950 - .4970
67.500 - .4740 - .4930
90.000 - .7760 - .6240
112.500 - 1.1700 - 1.1540
135.000 - 1.180 - 1.1770
157.500 .8110 .7890
180.000 1.1360 1.0600

RN (4) = 7.417 ALPHA (1) = 270.000 Q(PS1) = 34.410 TO = 51.000 RN = 7.4167 PO = 175.40

SECTION (1) SRB NOSE DEPENDENT VARIABLE CP

X/D 1.8100 2.1600

THETA

.000 - .6520 - .5930
22.500 - .6470 - .6690
45.000 - .6190 - .6430
67.500 - .6260 - .6350
90.000 - .9320 - .7470
112.500 - 1.2460 - 1.2930
135.000 - .1580 - .2140
157.500 .8030 .7730
180.000 1.0950 1.0590

RN (5) = 8.717 ALPHA (1) = 270.000 Q(PS1) = 40.290 TO = 47.000 RN = 9.7167 PO = 204.15

SECTION (1) SRB NOSE DEPENDENT VARIABLE CP

X/D 1.8100 2.1600

THETA

.000 - .6690 - .5390
22.500 - .6580 - .6700
45.000 - .6340 - .6590
67.500 - .6360 - .6480
90.000 - .9210 - .7670
112.500 - 1.2350 - 1.2500
135.000 - .1550 - .2090
157.500 .8050 .7740
180.000 1.1030 1.0530

MSFC HRMT 033 (SASBF) SRB FORWARD NOSE SECTION

(R1E108)

RN (6) = 9.667 ALPHA (1) = 270.000 Q(PSI) = 44.820 TO = 51.000 RN = 9.667 PO = 229.65

SECTION (1) SRB NOSE DEPENDENT VARIABLE CP

X/D	1.8100	2.1600
THETA		
.000	-.7040	-.6390
22.500	-.6890	-.7170
45.000	-.6620	-.7040
67.500	-.6640	-.7000
90.000	-.9620	-.8190
112.500	-1.2470	-1.2900
135.000	-.1590	-.2110
157.500	.8050	.7820
180.000	1.0910	1.0630

RN (7) = 12.750 ALPHA (1) = 270.000 Q(PSI) = 58.920 TO = 47.000 RN = 12.750 PO = 299.82

SECTION (1) SRB NOSE DEPENDENT VARIABLE CP

X/D	1.8100	2.1600
THETA		
.000	-.7240	-.6230
22.500	-.6870	-.7040
45.000	-.6630	-.7110
67.500	-.6660	-.6720
90.000	-.9650	-.8210
112.500	-1.2340	-1.2300
135.000	-.1620	-.2080
157.500	.7910	.7320
180.000	1.1240	1.0590

RN (8) = 13.167 ALPHA (1) = 270.000 Q(PSI) = 60.110 TO = 41.000 RN = 13.167 PO = 303.58

SECTION (1) SRB NOSE DEPENDENT VARIABLE CP

X/D	1.8100	2.1600
THETA		
.000	-.7420	-.6370
22.500	-.6800	-.6820
45.000	-.6590	-.7650
67.500	-.6610	-.6730
90.000	-.9800	-.8130
112.500	-1.2280	-1.2230
135.000	-.1480	-.1950
157.500	.7910	-2.2760
180.000	1.1090	1.0580

MSFC HRHT 033 (SA29F) SRB FORWARD NOSE SECTION (RIE108)

RN (9) = 16.083 ALPHA (1) = 270.000 Q(PSI) = 74.630 TO = 49.000 RN = 16.083 PO = 378.90

SECTION (1)SRB NOSE DEPENDENT VARIABLE CP

X/D 1.8100 2.1600

THETA	.000	-.7470	-.5880
22.500	-.7260	-.7490	
45.000	-.7030	-.8190	
67.500	-.7090	-.7260	
90.000	-1.0410	-.9120	
112.500	-1.2540	-1.2550	
135.000	-.1710	-.2120	
157.500	.7840	-3.1300	
180.000	1.1140	1.0600	

RN (10) = 20.050 ALPHA (1) = 270.000 Q(PSI) = 90.350 TO = 36.000 RN = 20.050 PO = 451.37

SECTION (1)SRB NOSE DEPENDENT VARIABLE CP

X/D 1.8100 2.1600

THETA	.000	-.6480	-.6040
22.500	-.6410	-.6640	
45.000	-.5330	-.7100	
67.500	-.5330	-.6310	
90.000	-.9440	-.8180	
112.500	-1.2230	-1.2280	
135.000	-.1510	-.1910	
157.500	.7970	-3.7420	
180.000	1.0970	1.0860	