

NASA CR-

147808

MCDONNELL DOUGLAS TECHNICAL SERVICES CO.  
HOUSTON ASTRONAUTICS DIVISION

SPACE SHUTTLE ENGINEERING AND OPERATIONS SUPPORT

DESIGN NOTE NO. 1.4-2-8

COMMONALITY STUDY OF THE PRESSURE-VOLUME-TEMPERATURE BASED  
PROPELLANT GAGING SOFTWARE MODULES FOR THE AUXILIARY POWER  
UNIT, REACTION CONTROL SYSTEM, AND ORBITAL MANEUVERING SYSTEM

MISSION PLANNING, MISSION ANALYSIS AND SOFTWARE FORMULATION

20 MARCH 1975

This Design Note is Submitted to NASA Under Task Order  
No. D0103, Task Assignment 1.4-2-A, Contract NAS 9-13970

PREPARED BY: D. D. Duhon

D. D. Duhon  
Task Manager, 1.4-2-A  
488-5660, Ext. 270

APPROVED BY: Walter W. Haufler

W. W. Haufler  
MIB/MAB Work Package Manager  
488-5660, Ext. 241

APPROVED BY: W. E. Hayes

W. E. Hayes  
WBS Manager, 1.4  
488-5660, Ext. 266

(NASA-CR-147808) COMMONALITY STUDY OF THE  
PRESSURE-VOLUME-TEMPERATURE BASED PROPELLANT  
GAGING SOFTWARE MODULES FOR THE AUXILIARY  
POWER UNIT, REACTION CONTROL SYSTEM, AND  
ORBITAL MANEUVERING (McDonnell-Douglas

N76-27356  
HC 3.50

Unclas  
G3/20 45775

## 1.0 SUMMARY

Computer storage requirements can be reduced if areas of commonality exist in two or more programs placed in the same computer and identical code can be used by more than one program. The pressure-volume-temperature (P-V-T) relationship for the propellant tank pressurant agent is utilized as the basis for either a primary or a backup propellant gaging program for the auxiliary power unit (APU), the reaction control system (RCS), and the orbital maneuvering system (OMS). An investigation of these three propellant gaging programs has revealed that a very limited degree of software commonality exists among them. An examination of this common software indicated that only the computation of the helium compressibility factor in an external function subprogram accessible to both the RCS and OMS propellant gaging programs appears to offer a savings in computer storage requirements.

## 2.0 INTRODUCTION

For the sake of completeness, the APU P-V-T propellant quantity gaging was reviewed for any commonality with the RCS and OMS gaging equations. The APU system design is entirely different from the RCS and OMS systems in that it is a monopropellant, blowdown system (not pressure regulated) and, as shown in Figure (1), there is no separate pressurant tank. Consequently, the APU gaging equations given in Reference (1) appear to offer little potential for saving

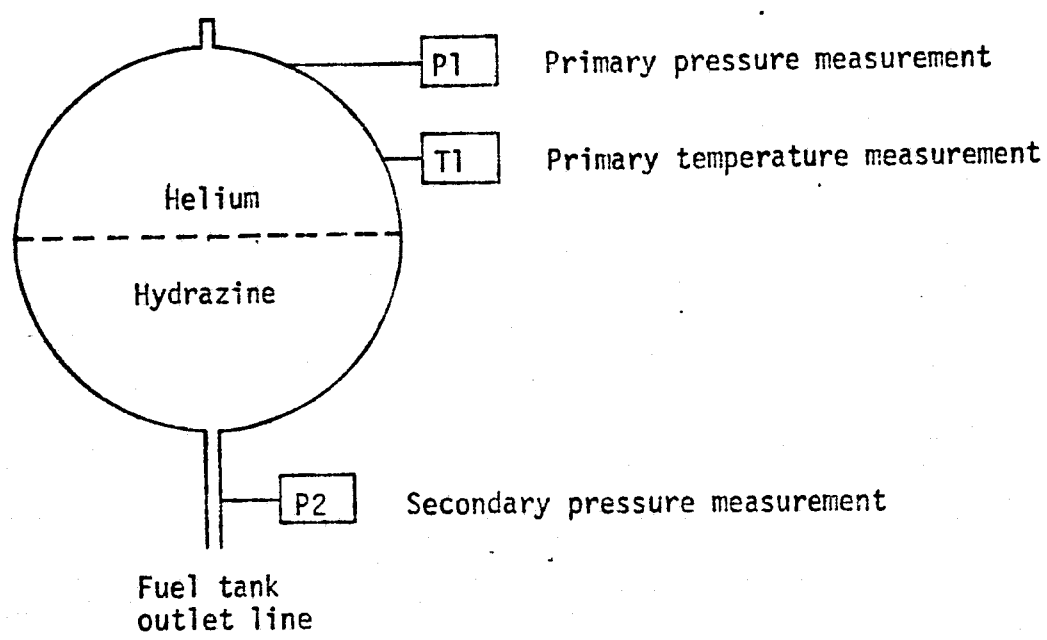

Figure 1. - Shuttle APU fuel tank and instrumentation.

computer storage by sharing logic with either the RCS or the OMS propellant gaging programs.

The RCS primary propellant gaging module, scheduled to be placed in the systems management (SM) function of the onboard computer, is presented in Reference (2). The RCS system utilizes monomethylhydrazine (MMH) as the fuel, nitrogen tetroxide ( $N_2O_4$ ) as the oxidizer, and helium gas (He) as the propellant system pressurant. A separate helium bottle is used to pressurize each propellant tank in the six RCS propellant tankage systems. The instrumentation for the P-V-T propellant gaging module consists of two pressure measurements (the average pressure is used) and one temperature measurement for each propellant tank and helium bottle. A typical RCS pressurant/propellant tankage system with its instrumentation is depicted in Figure (2).

The OMS propellant gaging module described in Reference (3) is to be placed in a ground based computer. However, this module may also be placed in the SM function of the onboard computer and used for backup OMS propellant gaging. The OMS system utilizes monomethylhydrazine as the fuel, nitrogen tetroxide as the oxidizer, and helium gas as the propellant system pressurizing agent. One helium bottle pressurizes two propellant tanks (one fuel tank and one oxidizer tank) in each of the three OMS propellant tankage

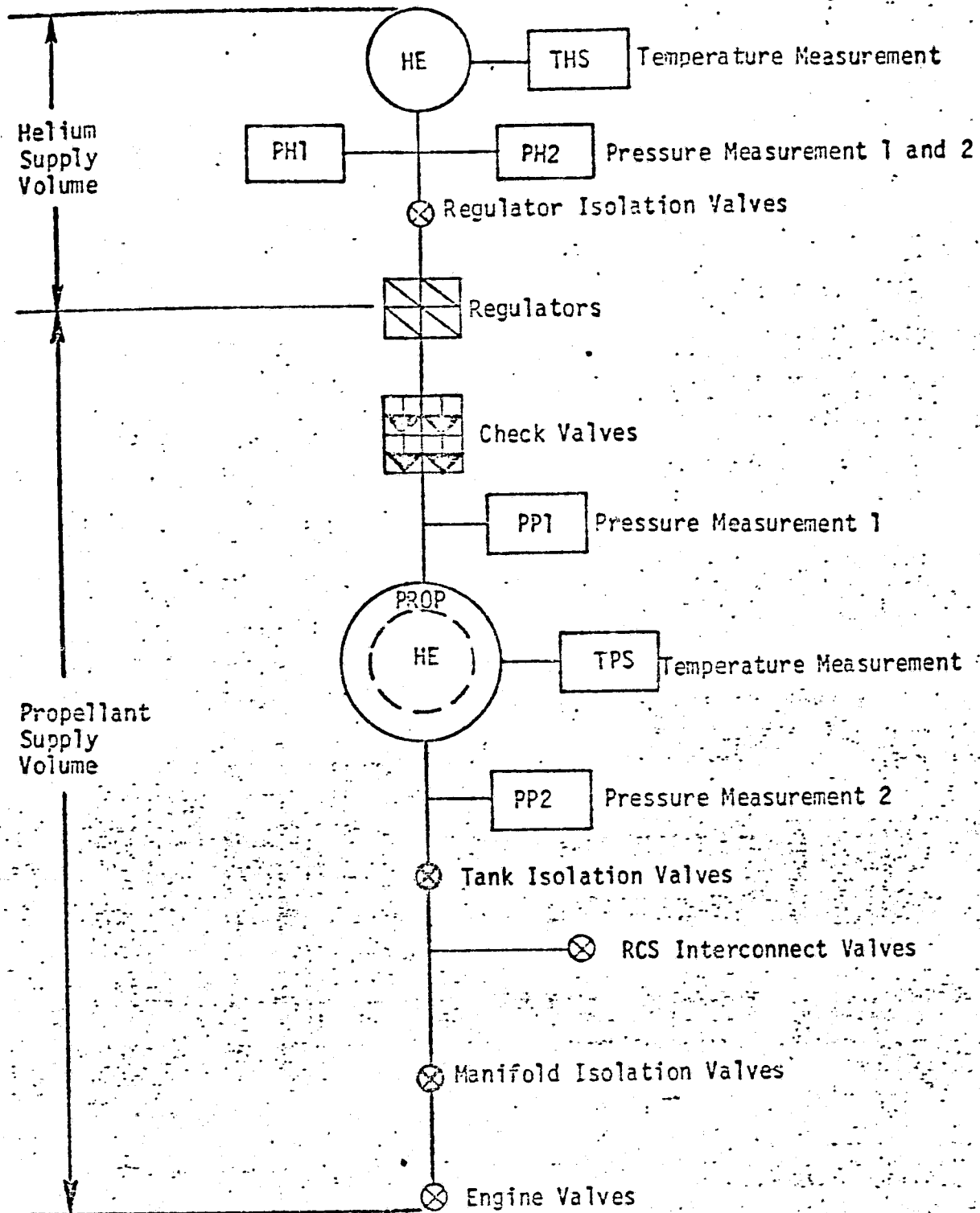

Figure 2. - Shuttle RCS Helium and Propellant Supply Systems and Instrumentation for Each Fuel and Oxidizer Tank

ORIGINAL PAGE IS  
OF POOR QUALITY

systems. The instrumentation for the P-V-T propellant gaging module consists of one pressure measurement and one temperature measurement for each helium bottle and propellant tank. The OMS baseline pressurant/propellant system with its instrumentation is shown in Figure (3).

### 3.0 DISCUSSION

The purpose of the three propellant gaging modules under examination is to enable the computation of the usable propellant remaining in the propellant tanks based on the real gas pressure-volume-temperature relationship for the propellant tank pressurant agent, helium. The computed quantities of propellant remaining are to be made available to the crew by means of a digital panel gage reading or a cathode-ray-tube(CRT) display, or both.

The real gas equation,  $PV = ZWRT$ , is used to determine the initial weight of helium in the pressurant/propellant system after system servicing but before system usage. The most important basic premise of the program calculations is that this weight of helium in the tankage system remains constant during system usage. After propellant usage has commenced, the real gas equation is used to compute the volume of the helium ullage in the propellant supply system. The remaining volume in the propellant supply system is assumed to contain propellant. The variables in the real gas equation are defined below.

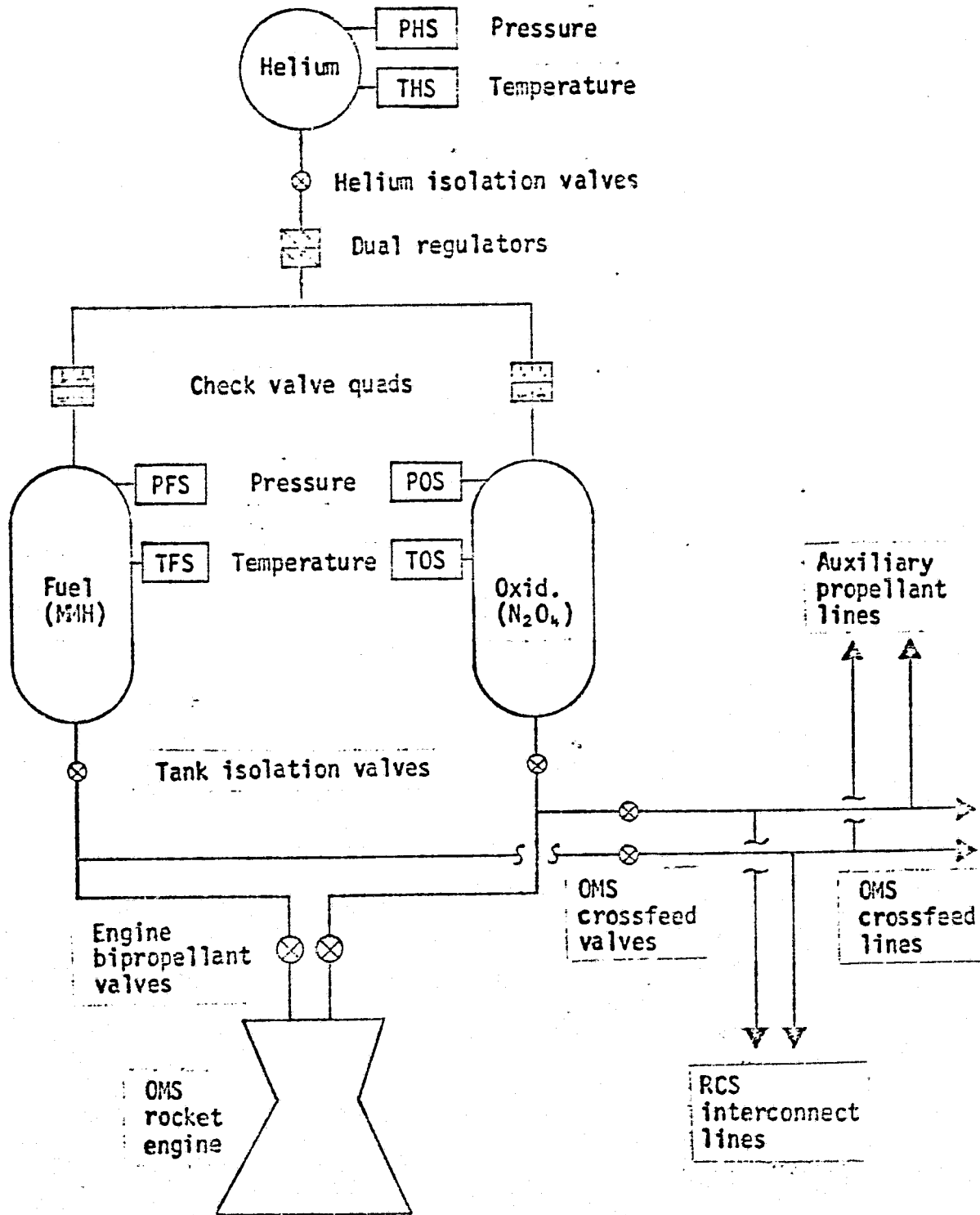

Figure 3. - Shuttle OMS baseline pressurant/propellant system and instrumentation.

P = helium partial pressure (total pressure less propellant vapor pressure), psia

V = helium volume, in<sup>3</sup>

Z = helium compressibility factor, nd

W = weight of helium in the system, lb

R = gas constant for helium, psia-in<sup>3</sup>/lb-°R

T = helium temperature, °R

The total pressure and temperature (in degrees Fahrenheit) are measured by sensors in the pressurant and propellant supply systems. The temperature is converted into degrees Rankine. The propellant vapor pressure is computed as a function of absolute temperature. The helium compressibility factor is computed as a function of absolute temperature and helium partial pressure.

While all three propellant gaging programs are based upon the real gas equation for helium, the unique combinations of propellants, tankage systems, and instrumentation result in program formulations which are necessarily quite different from each other. However, there are a few expressions which are identical and could be shared by two or more programs. These common expressions can be coded as functions and be made available to all programs placed in a computer in the same manner that library functions are used.

Expressions for the following quantities are common to at least



two of the three propellant gaging programs under examination.

1. Helium compressibility factor.
2. Monomethylhydrazine vapor pressure.
3. Nitrogen tetroxide vapor pressure.
4. Monomethylhydrazine density.
5. Nitrogen tetroxide density.
6. Corrected pressure measurement.
7. Corrected temperature measurement.

#### 4.0 RESULTS

The software for each of the seven quantities listed above was examined to determine the amount of computer storage that can be saved if an external function subprogram which calculates the quantity is accessible to two or more propellant gaging programs placed in the same computer. The results of these examinations are presented below.

##### 4.1 Helium Compressibility Factor

Since all three propellant systems examined use helium gas as the propellant tank pressurant, a prime candidate for commonality in the propellant gaging programs is the quadratic expression for the helium compressibility factor,  $Z$ . This expression, given below as a function of helium partial pressure,  $P$ , and absolute temperature,  $T$ , was derived by Rockwell International from data presented in

Reference (4).

$$A = 61.849 (T) - 9567.6$$

$$B = 21345.1 - 78.803 (T)$$

$$C = 16.995 (T) - (P) - 11761.6$$

$$Z = \frac{-B + \sqrt{B^2 - 4(A)C}}{2(A)}$$

At this juncture, the APU fuel gaging module was eliminated from further consideration in the commonality study due to 1) differences in system configuration, 2) different propellants, and 3) simplifying approximations for the helium compressibility factor and gas constant.

The complete RCS and OMS propellant gaging programs, described in References (2) and (3) respectively, were coded in Fortran language and executed on the Univac 1108 computer. The helium compressibility factor is computed at two or three places in each program. To avoid coding the same equations more than once, Z is computed in one long statement in the internal function FZ. Coding FZ as an internal function requires 41<sub>10</sub> storage locations. Coding FZ as an external function subprogram requires 52<sub>10</sub> storage locations, including 14<sub>10</sub> locations for subprogram overhead. If only one propellant gaging program is placed in the computer, FZ should be coded as an internal function. If both the RCS and OMS programs

are placed in the same computer, and FZ is coded as an external function subprogram, 30<sub>10</sub> storage locations can be saved.

#### 4.2 Monomethylhydrazine Vapor Pressure

The RCS and OMS propellant gaging programs compute the monomethylhydrazine vapor pressure, PFV, as a function of absolute temperature, T. This vapor pressure is computed at one place in each program utilizing the following expression from Reference (5).

$$PFV = \frac{10^{(31.746 - 5663.0/T)}}{51.715 (T/1.8)^{7.88}}$$

Removing the above equation from one propellant gaging program saves 19<sub>10</sub> storage locations. Coding PFV in an external function subprogram requires 46<sub>10</sub> storage locations. Even when two propellant gaging programs are placed in the same computer, no storage locations can be saved by coding PFV in an external function subprogram.

#### 4.3 Nitrogen Tetroxide Vapor Pressure

Both the RCS and OMS propellant gaging programs calculate the nitrogen tetroxide vapor pressure, POV, as a function of absolute temperature, T. This vapor pressure is computed at one place in each program utilizing the following expression from Reference (6).

$$POV = e^{(16.594 - 7367.0/T)}$$

Removing the above equation from one propellant gaging program

saves only 4<sub>10</sub> storage locations. Coding POV in an external function subprogram requires 27<sub>10</sub> storage locations. Clearly, there can be no savings in computer storage requirements by coding POV in an external function subprogram.

#### 4.4 Other Common Expressions

The remaining expressions common to the RCS and OMS propellant gaging programs are for the propellant densities and the corrected temperature and pressure measurements. All of these expressions consist of an equation for a straight line. The expression examined in Section 4.3 demonstrated that such a simple equation is best left in the main program because the computer storage overhead (about 14<sub>10</sub> locations) needed to create a new external function subprogram precludes any savings in computer storage.

### 5.0 CONCLUSIONS

Four conclusions were reached during the course of this study:

- A) There is no software commonality between the APU fuel gaging program and either the RCS or the OMS propellant gaging program which can be used to reduce the storage required to place either of these two combinations of programs in the same computer.
- B) The function for computing the helium compressibility factor is common to the RCS and OMS propellant gaging programs. If

these two programs are placed in the same computer, the helium compressibility factor should be calculated in an external function subprogram accessible to the two gaging programs. This action will result in a sizable net savings in computer storage requirements.

- C) The code for the corrected pressures and temperatures should be placed wherever the sensor measurements are converted from transducer voltages. These equations are considered to be a part of the sensor measurement accuracy rather than a part of the propellant gaging program. It may be possible to combine the conversion constants and calibration constants and save some computer storage in that manner.
- D) The computer storage required to code each of the other expressions common to the RCS and OMS propellant gaging programs is small relative to the overhead required to create a new subprogram. Therefore, all of these expressions should be coded within each of the gaging programs.

## 6.0 REFERENCES

1. Guidance and Dynamics Branch: Special Processing Functions for OV-101 in the Approach and Landing Test Program Volume I - Auxiliary Power Unit Fuel-Gaging Module. JSC Internal Note No. 74-FM-69, 27 Sept. 1974.
2. Mission Integration Branch: The Shuttle Reaction Control System Preliminary Propellant Gaging Module Computer Program Requirements. JSC Internal Note No. 75-FM-11, 27 Feb. 1975.

3. McDonnell Douglas Technical Services Company, Inc: The Shuttle Orbital Maneuvering System Preliminary P-V-T Propellant Gaging Module Computer Program Requirements. SSEOS Letter No. HAD-1.4-152, 27 Feb. 1975.
4. Whittaker Controls: The Physical and Thermodynamic Properties of Helium (Revised). Sept. 1960.
5. Aston, J. G.; Fink, H. L.; Janz, G. J.; and Russell, K. E.: The Heat Capacity, Heats of Fusion and Vaporization, Vapor Pressures, Entropy and Thermodynamic Functions of Methylhydrazine. J. Am. Chem. Soc., May 1951.
6. Bell Aerosystems Company: Titan II Storable Propellant Handbook (Revision A). Mar. 1962.