

OLD DOMINION UNIVERSITY RESEARCH FOUNDATION

DEPARTMENT OF PHYSICS AND GEOPHYSICAL SCIENCES
SCHOOL OF SCIENCES AND HEALTH PROFESSIONS
OLD DOMINION UNIVERSITY
NORFOLK, VIRGINIA

Technical Report PGSTR-PH76-39

(NASA-CR-148313) X-RAY EMISSION FROM HIGH TEMPERATURE PLASMAS Annual Report, 1 Jul. 1975 - 30 Jun. 1976 (Old Dominion Univ. Research Foundation) 40 p HC \$4.00 CSCI 201 N76-28015 Unclas 44537 G3/75

X-RAY EMISSION FROM HIGH TEMPERATURE PLASMAS

By

Wynford L. Harries

Annual Report
for the period July 1, 1975 to June 30, 1976

Prepared for the
National Aeronautics and Space Administration
Langley Research Center
Hampton, Virginia

Under
Research Grant NSG 1022

July 1976



DEPARTMENT OF PHYSICS AND GEOPHYSICAL SCIENCES
SCHOOL OF SCIENCES AND HEALTH PROFESSIONS
OLD DOMINION UNIVERSITY
NORFOLK, VIRGINIA

Technical Report PGSTR-PH76-39

X-RAY EMISSION FROM HIGH TEMPERATURE PLASMAS

By

Wynford L. Harries

Annual Report
for the period July 1, 1975 to June 30, 1976

Prepared for the
National Aeronautics and Space Administration
Langley Research Center
Hampton, Virginia 23665

Under
Research Grant NSG 1022
Dr. Frank Hohl, Technical Monitor
Environmental and Space Sciences Division

Submitted by the
Old Dominion University Research Foundation
Norfolk, Virginia 23508



July 1976

CONTENTS

	<u>Page</u>
ANNUAL REPORT ON NASA GRANT NSG 1022 X-ray Emission from High Temperature Plasmas	1
BIBLIOGRAPHY	5
APPENDIX A Trajectories of High Energy Electrons in a Plasma Focus . .	6
APPENDIX B Detection of Ion Trajectories	29
APPENDIX C Spatial Distribution of Neutron Emission	30
APPENDIX D Emission of X rays from a Plasma Focus vs Position on a Fast Time-Scale	31

ANNUAL REPORT

NASA GRANT NSG - 1022

X-ray Emission from High Temperature Plasmas

by

W.L. Harries*

The investigation is a continuation of contract NAS1-11707-23 which ran 1 July 1973 to 30 June 1974. It was renamed NSG 1022 and renewed 1 July 1974, and on 1 July 1975. This report covers the period 1 July 1975 to 30 June 1976.

The work is an experimental investigation carried out at NASA Langley Research Center using their facilities. The experiments were done on the Focus I and Focus II devices in collaboration with J.H. Lee of Vanderbilt University working under NASA Grant NGR 43-002-031, and D.R. McFarland of NASA.

The purpose of the work is to investigate the physical processes occurring in Plasma Focus devices. These devices produce dense high temperature plasmas, which emit x rays of hundreds of KeV energy and 10^9 - 10^{10} neutrons per pulse. The processes in the devices seem related to solar flare phenomena, and would also be of interest for controlled thermonuclear fusion applications. The high intensity, short duration bursts of x rays and neutrons could also possibly be used for pumping nuclear lasers.

*Professor of Physics, Old Dominion University, Norfolk, Va. 23508

The specific objective was to investigate x-ray emission. The emission was closely related to the dynamics of the electrons and in particular the trajectories of the high energy electrons. Experiments performed during this period included the "shadow" method of detecting the direction and angular spread of the high energy electrons, using a hollow anode with a hole in its upper surface. Another experiment consisted of placing a plate above the focus and observing its lower surface for low energy x-ray emission - none was observed indicating that there were hardly any electrons travelling away from the anode at any time. Details of these experiments together with previous work have been incorporated into a paper to be submitted to Plasma Physics, "Trajectories of High Energy Electrons in a Plasma Focus", - Appendix A.

It became evident that accelerated beams of electrons existed, that could only have been formed by strong electric fields. These fields were directed away from the anode and would also accelerate the ions. The picture was found consistent with the converging beam model of neutron production, proposed previously by J.H. Lee⁽¹⁾. Therefore several experiments were made to detect ions moving away from the anode. The experiments were not successful, and details are given in Appendix B - "Detection of Ion Trajectories".

1. Lee, J.H., Shomo, L.P., Williams, M.D. and Hermansdorfer, Phys. Fluids 14, 2217 (1971).

The acceleration of the ions was related to neutron production, and attempts were made to obtain the spatial distribution of neutron emission. The experiments were very difficult and not successful, and details are given in "Spatial Distribution of Neutron Emission," - Appendix C.

The period since January 1976 has been spent observing the plasma with electronic cameras and the Imacon image intensifier. The purpose of the experiments was to observe by streak and framing techniques, the distribution in space and time of both visible light, and x rays. Observations on a faster time scale than any used hitherto might be important in determining the mechanisms of the focus. The method has worked for visible light, x rays of energies over 1 KeV, and over 20 KeV in the streak mode. So far the results indicate that the emission of the x rays is mostly from copper vapor from the anode surface. Details of the experiment are given in Appendix D - "Emission of X rays from a Plasma Focus vs Position on a Fast Time Scale".

The work above has been carried out on the Focus I machine and has resulted in four papers given at meetings which are shown in the bibliography. A manuscript is to be submitted shortly for publication.

The grant has been renewed from 1 July 1976 to 30 June 1977. Future experiments will be carried out on the Focus II machine. The Focus I device had 25KJ of energy at 20KV, in its capacitor

bank whereas Focus II has 50KJ at 50KV, thus giving a variation in parameters. All the techniques used on Focus I can be applied to Focus II. In particular methods of increasing the emission of x rays and neutrons will be investigated.

The collaboration of J.H. Lee and D.R. McFarland in this work is gratefully acknowledged.

BIBLIOGRAPHY

1. "Fine Structure of Hard X-ray Emission from a Plasma Focus Apparatus". W.L. Harries, J.H. Lee, and D.R. McFarland, Bull. Am. Phys. Soc., 19, 511 (1974).
2. "Space and Time Resolved Observations of X-ray Production in a Plasma Focus Apparatus". J.H. Lee, W.L. Harries, and D.R. McFarland, First IEEE International Conference on Plasma Science, Knoxville, Tennessee, 15-17 May 1974, Paper 2C11.
3. "Electron Dynamics in a Plasma Focus Based on X-ray Measurements". W.L. Harries, J.H. Lee, and D.R. McFarland, Bull. Am. Phys. Soc., 19, 945 (1974).
4. "Trajectories of High Energy Electrons in a Plasma Focus". Bull. Am. Phys. Soc., 20, 1370 (1975).
5. "Trajectories of High Energy Electrons in a Plasma Focus". W. L. Harries, J.H. Lee, and D.R. McFarland, submitted to Plasma Physics.

APPENDIX A

TRAJECTORIES OF HIGH ENERGY ELECTRONS IN A PLASMA FOCUS

Wynford L. Harries
Department of Physics,
Old Dominion University, Norfolk, Virginia 23508

Ja H. Lee
Department of Physics and Astronomy,
Vanderbilt University, Nashville, Tennessee 37235

and

Donald R. McFarland
NASA Langley Research Center, Hampton, Virginia 23665

ABSTRACT

The intensity of x rays from a plasma focus was measured versus position, time, energy, and angle of emission. The low-energy x-rays emanated from the plasma, but the high-energy components came from a small region of the anode surface, on axis. Emission from the focus occurred some 20 ns prior to that from the anode, but the latter continued for 500 ns. X-ray "shadow" techniques showed that the high-energy electrons traveled in a beam almost perpendicular to the anode surface. Spatial plots of x-ray intensity at different energies showed that the electrons gained energy as they approached the anode. No counter streaming of high-energy electrons away from the anode was evident. Polar diagrams of medium-energy (≈ 20 keV) x-rays resembled a cardioid, but high-energy (≈ 100 keV) x rays were emitted in a narrow lobe toward the anode, with a forward-to-back ratio of about 50; both results are consistent with Bremsstrahlung emission from a beam of relativistic electrons. The relativistic beam current was estimated at several 100 A. The electric fields required to produce such electron trajectories are also consistent with the observed anisotropy of ion emission in a focus, and with the converging beam model of neutron production, proposed previously.

INTRODUCTION

The mechanism by which x rays of hundred of keV and neutrons are emitted from plasma focus devices (Mather, 1964) is not well understood. It was thought at first that the neutrons and x rays were emitted by thermal processes (Mather, 1965; Beckner, 1966, 1967), i.e., collisions of particles in isotropic Maxwellian distributions in the deuterium plasmas. The plasma densities were over 10^{19} cm^{-3} and the electron and ion temperatures were several kilovolts (Peacock et al, 1968). However, Beckner, Clothiaux, and Smith (1969) showed that the dominant x-ray emission was due to nonthermal high-energy electrons striking the anode and suggested that high electric fields existed. Bernstein et al (1969) showed that the x-ray photon distribution did not appear to be due to electrons in a Maxwellian distribution. Instead, it obeyed a power law, and was proportional to $E^{-\gamma}$, where E is the photon energy and $\gamma = 2$ for $7 < E < 29$ keV. Lee, Leobaka and Roos (1971) showed similar behavior occurred above 100 keV except that γ was about 4. Anisotropy in the intensity of x rays, with a reduced signal on axis, was also reported by Jalufka and Lee (1972). Maisonnier et al (1975) have also suggested the plasma, in a Filippov-type device, was heated by an energetic electron beam.

Neutron production was also consistent with the concept that strong electric fields accelerate the ions to high velocities. A mechanism for the ion acceleration has been suggested by Bernstein (1970). The ion energy distribution was deduced from measured anisotropies of neutron energy and fluence by Lee et al (1971, 1972).

However, several questions yet remained unanswered. First, what was the polarity of the fields? Recently, Newman and Petrosian (1975) claimed the field was directed toward the anode, and the electrons should be accelerated away from it. Second, could the polarity of the field change in time? Third, how did beams of accelerated particles cross the magnetic field configuration?

The purpose of this investigation is to determine the trajectories of the high-energy electrons in the focus by observing the Bremsstrahlung x rays emitted, and to infer the electric field configuration from the trajectories. Section II describes the experimental method and results. The direction and angular spread of electron velocities are investigated, and new measurements of anisotropy of x-ray flux at different energies are reported. In section III measurements by other authors of ion and neutron anisotropy are discussed and shown to be consistent with our results.

EXPERIMENTAL METHOD AND RESULTS

A. Plasma-Focus Device

The plasma-focus device was a Mather type, and is reported elsewhere (Lee et al, 1971; Jalufka et al, 1972). It consisted of coaxial cylindrical electrodes, 23 cm long, with a cathode of 10 cm diameter, and an internal anode of 5 cm diameter, both of copper (Fig. 1). They were enclosed in an aluminum sphere of 2 mm wall thickness and 30 cm diameter. The filling gas was deuterium at about 5 Torr. The capacitor bank provided 25 kJ energy at 20 kV. During the "focus" state, the plasma was compressed into a volume $\approx 10^{-2} \text{ cm}^3$, with densities $\approx 10^{19} \text{ cm}^{-3}$, and electron temperatures of several kilovolts. Copious neutrons, $\approx 10^{10}$ per focus were produced as well as intense x rays of over 100 keV.

B. Spatial Distribution of X Rays

Pinhole camera techniques for x rays are well known (Beckner et al, 1969). In contrast to previous measurements, we have recorded x rays up to 100 keV energy, (values higher than the voltage of the capacitor bank and in a range where there were no copper lines.) The pinholes were in 2-cm thick lead and were tapered to a minimum diameter of 0.4 mm. Each camera had several pinholes and 1:1 images were formed on an image intensifier screen (Du Pont Chronex Lightning type), 15 cm behind the pinhole. Contact prints were recorded on Polaroid 3000 or 10,000 ASA film.

X rays of energies above 1 keV were recorded through a 250 μm Beryllium window (Fig. 1, A), those above 15 keV through the 2 mm aluminum vacuum vessel as shown in Figure 1, B, and those above 20, 30 and 50 keV were recorded by using lead filters of 102, 254 and 762 μm thickness respectively, observing through the vessel. The filters were used simultaneously, and both single and multiple shots were recorded. The results are summarized in Fig. 2a and confirm the observations of Beckner et al (1969) that the soft x rays came from the plasma and the hard x rays from the anode surface. The new result here is that the hardest x rays were emitted from a small region of the surface, on the axis. Observations from C, (Fig. 1) confirmed that x rays above 30 keV were emitted from a radius of approximately 1 mm diameter.

The response of the intensifier screen-film combination was not determined, so pinhole images of the x rays were also recorded on two 9 x 9 rasters of type 400 thermoluminescent detectors (TLD) (Cameron et al, 1968). These were small cubes, 3 x 3 x 0.75 mm, and on exposure to x rays stored some of the energy in metastable states. On being heated in a commercial analyser, visible light was emitted proportional to the intensity of the x-ray dose. Their reliability is discussed in Section D. X rays of energy greater than 15 keV and greater than 30 keV energy were recorded from 25 focuses (Fig. 2b). The readings were approximately proportional to x-ray intensity and confirmed Fig. 2a except that the TLD's showed that x rays of over 30 keV were emitted from the plasma approximately 0.5 cm above the anode. Both experiments showed the high energy x rays emanated from near the axis, consistent with a model based on an accelerated electron beam. A beam would also explain the erosion of the anode, which occurred on axis. The first few shots showed a just discernible depression of approximately 1 mm radius; after 100 focuses it was about 1 mm deep and several mm in diameter.

C. Direction of Electron Velocity Vectors

The angular spread of electron velocities was next estimated. The electron paths were determined from the x rays emitted, by using a "shadow" method. A hollow anode was constructed, with an aluminum cap forming its upper surface, which had a 5 mm diameter hole on axis (Fig. 3). The hole did not appear to affect the discharges, and x rays of over 30 keV were recorded by a pinhole camera at $\theta = 45^\circ$, outside the vacuum vessel. The aluminum cap was transparent to x rays of this energy so it was possible to record emission from the upper surface of the cap at A (Fig. 3b), and from the floor of the cavity at B, on the same film. The two outlines of the hole, indicated that the main body of > 30 keV electrons had traveled essentially in paths almost perpendicular to the anode surface with an angular spread of less than 10° . However, exposure to 20 focuses revealed the whole outline of the bottom of the cavity, suggesting lower energy electrons were traveling at large angles relative to the axis.

We next checked whether at any time there were some electrons traveling away from the anode. A pinhole camera monitoring region D of the vessel (Fig. 1) (for x rays > 15 keV observed through the vessel) showed no evidence of emission when the same film was exposed to over 20 focuses. An insulated aluminum plate was then positioned above the anode (Fig. 4) and observed through a 250 μ m beryllium window. The plate did not seem to affect the plasma parameters when its center was more than 3 cm above the anode, and focuses were still obtained even when it was only approximately 1 cm from the anode. However, at this position, the neutron emission was considerably reduced although x rays from the anode surface were still evident. The field of view of the camera encompassed the anode and plate and recorded emission from the plasma as in Fig. 2a, but none whatever was recorded from the plate at any position. X rays down to 1 keV from its lower surface would have been recorded if they had been present. The lack of emission suggests there were few high energy electrons streaming upwards at any time.

D. Angular Dependence of X-ray Emission

Angular dependence was measured using type 400 thermoluminescent detectors. There is a general impression that TLD's are unreliable for quantitative x-ray measurements. Wide variations in readings were found when the TLD's were inadequately shielded from reflected x rays. However, lead containers of 3 mm thickness (Fig. 1, E and F) designed so that the detector saw only the plasma, made the readings consistent; 18 detectors exposed simultaneously gave readings within $\pm 5\%$. Tests using lead filters to reduce x rays and boron filled polythylene to reduce neutron flux, showed the signals were approximately proportional to x ray and not neutron intensity.

The TLD readings, however, were dependent on the energy of the x rays. The fraction η of energy retained in the TLD was estimated by sending a collimated x-ray signal through two detectors in series. If the incident signal flux was I , and the signals from the first and second TLD were s_1 and s_2 , respectively, then $s_1 = \eta I$, and $s_2 = \eta(1 - \eta)I$, or

$$\eta = 1 - s_2/s_1 \quad (1)$$

A rough estimate of η vs energy E was made by using lead filters. The thickness of the filter essentially determined the lower energy limit for x ray transmission, while the upper energy limit was a rough estimate only, as the x ray distribution function versus E was not known. A value of 0.49 ± 0.05 was determined for x rays of $15 < E < 25$ keV, and a value of 0.15 ± 0.06 for the range of $30 < E < 50$ keV (Backscatter of low-energy x rays into the rear TLD did not affect these estimates as the results were similar with a lead surface adjacent to the rear TLD, and with the surface removed 2 cm away, and shielded with aluminum, a good absorber.) The value of η will be used later in comparing emission of different energies.

Estimates of x-ray flux vs emission angle θ were made by placing the TLD's every 15° outside the vessel for $0 < \theta < \pi/2$ (Fig. 1,E). The anode and cathode intervened for $\pi/2 < \theta < \pi$ but readings at $\theta = \pi$ were obtained by placing detectors in a cavity 15 cm below the focus (Fig. 1,G). The detectors were protected by the cap H, 2 mm thick.

The cap was first made of copper, the usual anode material, so it was necessary to normalize readings at G through copper to those at E through aluminum. Therefore, detectors were also placed at F behind 2 mm copper. Separate runs were also taken with H of 2 mm aluminum; the discharge parameters seemed to be unaffected by changing H from copper to aluminum.

At each angle θ , energy analysis was performed by simultaneously using lead filters of thicknesses 0, 102, 203, 256, 508 and 762 μm . Three detectors recorded for each filter, except at G where there was only one per filter (insufficient space). Emission from over 20 focus shots was superimposed on the TLD's for each anode material. The upper limit to the number of shots was dictated by the amount of erosion of the cap, which was small in each instance.

Polar diagrams of intensity of x rays in the 15 keV range with an aluminum cap were obtained (Fig. 5a). The points at $\theta = \pi/2$ are due to the anode and cathode intercepting the x rays. The pattern confirms reduced emission at $\theta = 0^\circ$ (Jalufka et al, 1972). The extra point at $\theta = \pi$ suggests the pattern is a cardioid. However, the pattern for aluminum with a 762 μm filter, (energies > 50 keV) (Fig. 5b) is greatly different. The signals were reduced two orders of magnitude, but more important, a forward lobe ($\theta = \pi$) about 50 times greater than the sideways or backward signal, was evident. The polar diagrams for intermediate energies were intermediate between a cardioid and a narrow lobe.

Similar results were obtained with copper. The 2 mm thick copper transmitted energies > 30 keV, and the two triangles (Fig. 5a) normalized to the signal at 45° suggest a slightly forward oriented lobe. X rays > 50 keV showed a pronounced lobe with a forward to back ratio of about 40 to 1. The pronounced anisotropy of the high energy x rays will be discussed in Section III.

E. Total X-ray Energy Emitted

The total x-ray energy per focus was estimated using TLD's which had been calibrated using a standard x-ray source. The estimate was in order of magnitude only, as the energy dependence of the emission from the plasma and the calibration source were different. The relative response to the TLD's to the 0.662 MeV x rays from the Cs 137 source was about 1/10 the response to x rays of 10 to 100 keV (Cameron et al, 1968). The average dose per focus on TLD's placed 15 cm away outside the vessel at $\theta = 45^\circ$, was approximately 4 mR. Assuming 1% transmission (averaged over energy) through 2 mm aluminum, the total energy per focus for x rays > 15 keV was of order 10 mJ. The dose on a TLD measuring x rays > 50 keV at $\theta = 45^\circ$ was 50 times smaller than the dose at $\theta = \pi$. The total energy per focus for x rays > 50 keV was estimated to be ≈ 1 mJ, after taking account of the anisotropy.

F. Time of Emission of X Rays

The purpose of this experiment was to see if the x rays from the plasma and from the anode surface were emitted at different times. A pinhole camera formed an image on an intensifying screen, and two light pipes were placed against the image, observing the dense focus region, and the anode surface region respectively. The light signals were monitored with two separate photomultipliers and displayed on an oscilloscope.

The light pipes used were polished aluminum tubes, as the commercially available fiberglass type became fluorescent from the x rays and neutrons. The intensifying screen had a rise time of a few ns, and a decay time of several ms. The x rays from the focus region were observed to occur 20 ns before those from the anode surface region. The latter signal continued to increase in amplitude for several hundred nanoseconds, indicating that x-ray emission persisted beyond the apparent focus lifetime of 200 ns. This long emission time was in agreement with the scintillation detector signal.

DISCUSSION

In the dense focus, values of $n_e = 10^{19} \text{ cm}^{-3}$, and T_e and T_i of several keV are generally accepted. Assuming T_i and $T_e = 3 \text{ keV}$, the electron and ion self collision times are estimated as 1 and 60 ns respectively. The duration of soft x-ray emission from the focused plasma, which for our purposes we shall regard as a containment time τ_c , is about 200 ns, so the electron velocity distribution should be Maxwellian in the focus. Here the Debye length is estimated as 10^{-5} cm , much less than the plasma dimension, so the focused plasma probably maintains electrical neutrality. Indeed low-energy x rays corresponding to an electron temperature of a few keV are observed as in Fig. 2(a).

The rasters of Fig. 2(b) which were placed on the image plane of a pinhole camera were used to obtain the spatial distribution of the ratios of doses through two different filters. The ratios can yield T_e if a Maxwellian distribution is established by using the method of Elton and Anderson (1967). Unfortunately, the doses through the thicker filter corresponding to the dense focus region about 2 cm above the surface were too small to be measured, even after exposures to 25 focuses. Estimates of 5 to 10 keV electron temperature were obtained for the region about 0.5 cm above the anode, but it is doubtful that a Maxwellian distribution is applicable there. The ratios, however, give some measure of an average

energy for the electrons. The ratios decrease on approaching the anode surface implying a higher average energy there than in the plasma. The region of highest energy is on axis on the anode surface. Very qualitative estimates of point by point intensity ratios taken from the intensifier screen-polaroid film combination confirm this result.

The observation of x rays of energies > 50 keV from the anode surface on axis, (Fig. 2 and Fig. 3b) implies electrons are traveling in a beam toward the anode. Therefore, strong electric fields exist between the dense focus and the anode, sufficient to accelerate electrons to energies of order 100 keV over a distance of order 1 cm. Fields of such magnitude would have caused all electrons over 200 eV to run away if $n_e = 10^{19} \text{ cm}^{-3}$ (particle-particle collisions only are taken into account).

We consider next the effect of the magnetic field $B_\theta(r)$ created by the current through the plasma on the electron trajectories. The total current is about 1 MA at the instant of focus formation and should create an azimuthal magnetic field of 100 T around the current column of radius $r_0 = 1$ mm. Inside the current column $B_\theta(r) \propto r$; $r < r_0$, (assuming constant current density, which may not be true). During compression, the plasma and field are "frozen" together (the diffusion time through a distance r_0 at $T_e = 3$ keV is 4×10^{-4} sec, much greater than τ_c). However, on axis, $B_\theta(0) = 0$ so a beam of particles can travel on or near the axis from the focus to the anode without deflection by the field.

The polar diagrams (Fig. 5) confirm the high energy x rays are caused by electrons with an anisotropic velocity distribution. The emission of Bremsstrahlung from a directed beam of electrons is well known, and the intensity $\Pi(\phi)$ per electron per unit solid angle per sec. is (see, for example, Leighton, 1959):

$$\Pi(\phi) = \frac{q^2 a^2 \sin^2 \phi}{16 \pi^2 \epsilon_0 c^3 (1 - \beta \cos \phi)^5} \quad (2)$$

Here q is the charge of the electron, a a magnitude of the acceleration, ϵ_0 the dielectric constant of free space, $\beta = v/c$, v the electron velocity, c the velocity of light, and ϕ the angle of emission relative to the forward direction of the electron. The radiation patterns for different electron energies (Fig. 6a) show that as β increases, the radiation is predominantly forward. Then the intensity at $\theta = \pi - \phi$ would be the sum of patterns similar to Fig. 6a from electrons whose velocity vectors lie in a cone at any angle up to α relative to the axis of symmetry (Fig. 6(b)). The intensity versus θ for 20 keV would be a cardioid, (Fig. 5(a)), and for 100 keV would resemble a forward lobe, (Fig. 5(b)). The pattern for copper (≈ 30 keV) would be intermediate, as observed.

Although the emission is thick target Bremsstrahlung, the argument is still consistent as the high-energy Bremsstrahlung is mostly due to first deflections. Comparison of Figs. 5(b) and 6(a) suggest values of $\beta \approx 0.5$ indicating electrons of energy approaching 100 keV, consistent with the transmission data obtained with lead filters.

Very rough estimates of the total energy in the runaway current can be made. Our measurements show the total energy in x rays above 50 keV is of order 1 mJ. The runaway current is estimated assuming it consists of a monenergetic beam of electrons, all of energy $E = 50$ keV. The efficiency of energy conversion from such a beam into x rays is roughly

$$\alpha = 10^{-9} EZ \quad (3)$$

where Z is the atomic number of the target (Patou, 1970). Then α is 1.5×10^{-3} and hence the electron beam energy is of order 1J.

A beam of 50 keV electrons lasting for 100 ns and of 1J total energy corresponds to an average current of 200 A.

A theoretical estimate of the runaway current in a focus has been made by Hohl and Gary (1974). They assume that the beam has much higher current density than the surrounding plasma, and creates the magnetic field in its neighborhood. Then all particles within a gyroradius r_L of the axis (r_L is calculated from the field at the edge of the beam) contribute to the runaway current I_{run} :

$$I_{run} = 2\pi(mKT)^{1/2}/\mu_0 e \quad (4)$$

where m is the mass, e the charge, T the temperature of the particle, and μ_0 the permeability of free space. For electrons with $kT_e = 3$ keV, $I_{run} = 600A$ agreeing in order with our values. The theory yields a beam radius of 1 μm . The experiments (hard x-ray emission, (Fig. 2(a)), and the erosion) indicate a beam diameter of approximately 1 mm at the anode surface. However, there could have been spreading of the beam between the focus region and the surface of the anode.

Estimates of beam currents in a focus device are reported by Maissonier et al (1975) which are several orders of magnitude higher than ours. However, the experiments were performed in a Filippov type device with a 40 kV, 74 kJ capacitor bank. Any comparison with their results is difficult because of very different parameters.

The plasma sheath is probably formed just after maximum compression because the plasma x rays appear slightly before the x rays from the anode. This picture is consistent with computer simulations of Hohl et al, (1974).

The electric field should also accelerate ions away from the anode. Evidence of erosion was clearly visible on the inner surface of the vacuum vessel at $\theta = 0^\circ$. Recently Gullickson (1975) has shown that the flux of energetic ions from a Mather device showed a very sharp peak at $\theta = 0^\circ$.

The production of neutrons is also consistent with a beam of ions accelerated to energies of order 100 keV, and converging on the dense plasma. This mechanism has been proposed previously by one of us (Lee et al, 1971) as the converging beam model to explain the observed anisotropy of the neutron flux of the plasma focus.

CONCLUSIONS

Spatial resolution of the x-ray emission from a plasma focus confirms that the low-energy x rays are emitted from the plasma and the high-energy (> 50 keV) x rays are emitted from the anode surface. In addition, new evidence is presented that the highest energy x rays come from a small region (diameter ≈ 1 mm) on axis as shown by an intensifier screen-polaroid sensor, by TLD rasters, and from anode erosion.

The low-energy emission is consistent with a thermal plasma of a few keV energy. The high-energy emission is consistent with an accelerated beam of electrons with energies of order 100 keV. The electron beam reaches the anode 20 ns after the dense plasma formation.

The existence of a directed beam of this energy implies a sheath region of very high fields between the dense focus and the anode. The presence of the sheath is assumed in this paper, and the mechanism by which it is created is not discussed.

The direction of the electron beam is essentially perpendicular to the anode, as shown by the "shadow" experiment. There does not seem to be any streaming away from the anode at any time as shown by lack of emission from the underside of the plate. The electrons gain energy on approaching the anode as shown by both the TLD raster and the intensifier screen-polaroid film experiments.

The plasma conditions are consistent with a "runaway" electron beam. The magnetic field configuration would have allowed the passage of the beam from the focus to the anode, only near the axis, as observed.

The energy and current in the beam are roughly estimated from the x-ray emission. The results are very approximate but show the beam energy for electrons over 50 keV is of order 1J and the current of order 200 A. A theoretical estimate yields 600 A - agreeing in order. Polar diagrams of x-ray intensity show that low-energy emission is approximately isotropic. However, there is marked anisotropy in x rays of energies over 50 keV, which show a lobe in the direction of the anode with a forward-to-back ratio of 50 to 1. The lobe is consistent with a relativistic beam of electrons of energies of order 100 keV directed toward the anode.

The above results show that the electric fields are directed away from the anode - a conclusion which contradicts the postulate of Newman and Petrosian (1975). A field directed away from the anode would be consistent with the anisotropy of ion flux, measured by Gullickson (1975), and also consistent with the converging beam model of neutron production (Lee et al, 1971).

ACKNOWLEDGEMENTS

The authors would like to thank Dr. Frank Hohl for his interest and support, and to both he and Dr. S. Peter Gary for valuable discussions. The work was carried out at the National Aeronautics and Space Administration Langley Research Center, and supported in part under grants NAS1-11707-23, NAS1-1022, and NGR 43-002-034.

REFERENCES

- Beckner, E. H., Clothiaux, E. J., and Smith, D. R., Phys. Fluids 12, 253, (1969).
- Beckner, E. H., J. App. Phys. 37, 4944 (1966); Rev. Sci. Instr. 38, 507 (1967).
- Bernstein, M. J., Meskan, D. A., and Van Paassen, H. L. L., Air Force Report No. SAMS0-TR-69-304 of September 1969.
- Bernstein, M. J., Phys. Fluids 13, 2858 (1970).
- Cameron, J. R., Suntharalingam, N. and Keeney, G. M., "Thermoluminescent Dosimetry" (Wisconsin Press) 1968).
- Elton, R. C., and Anderson, A. D., Applied Optics 6, 2071 (1967).
- Gullickson, R. H., "Measurement of the Distribution of Very Energetic Ions in the Plasma Focus Device" UCRL-76831 (1975).
- Hohl, F., Gary, S. Peter, National Aeronautics and Space Administration, Technical Note TN-D7707, November 1974, Submitted to Phys. Fluids.
- Jalufka, N. W., and Lee, J. H., Phys. Fluids 15, 1954 (1972).
- Lee, J. H., Shomo, L. P., Williams, M. D., and Hermandorfer, H., Phys. Fluids 14, 2217 (1971).
- Lee, J. H., Leobbaka, D. S., and Roos, C. E., Plasma Physics 13, 347 (1971).
- Lee, J. H., Shomo, L. P., and Kim, K. H., Phys. Fluids 15, 2433 (1972).
- See for example, Leighton, R. B., "Principles of Modern Physics" McGraw Hill 1959, p. 413.
- Maisonnier, C., Gourlan, C., Luzzi, G., Papagno, L., Pecorella, F., Rager, J. P., Robouch, B. V., Samuelli, M., IV Conference on Plasma Physics and Controlled Nuclear Fusion Research, Madison 1971, IAEA Vienna, Vol. 1, p. 523.

- Maisonnier, C., Pecorella, F., Rager, J. P., Samuelli, M., Strangio, C., and Messina, A., Comparative Studies of Plasma Focus Devices, IAEA-35/E6-2, Fifth Conference on Plasma Physics and Controlled Nuclear Fusion Research (Tokyo, Japan), Nov. 1975.
- Mather, J. W., Phys. Fluids Suppl. 7, S28 (1964).
- Mather, J. W., Phys. Fluids 8, 366 (1965).
- Newman, C. E., and Petrosian, V., Phys. Fluids 18, 547 (1975).
- Patou, C., Journal de Physique, 31, 334 (1970).
- Peacock, N. J., Wilcock, P. D., Spær, R. J., and Morgan, P. D., Third Conference on Plasma Physics and Controlled Nuclear Fusion Research, Novosibirsk, U.S.S.R., 1-7 August 1968.
- Van Paassen, H. L. L., Vandre, R. H., and White, R. S., Phys. Fluids 13, 2606 (1970).

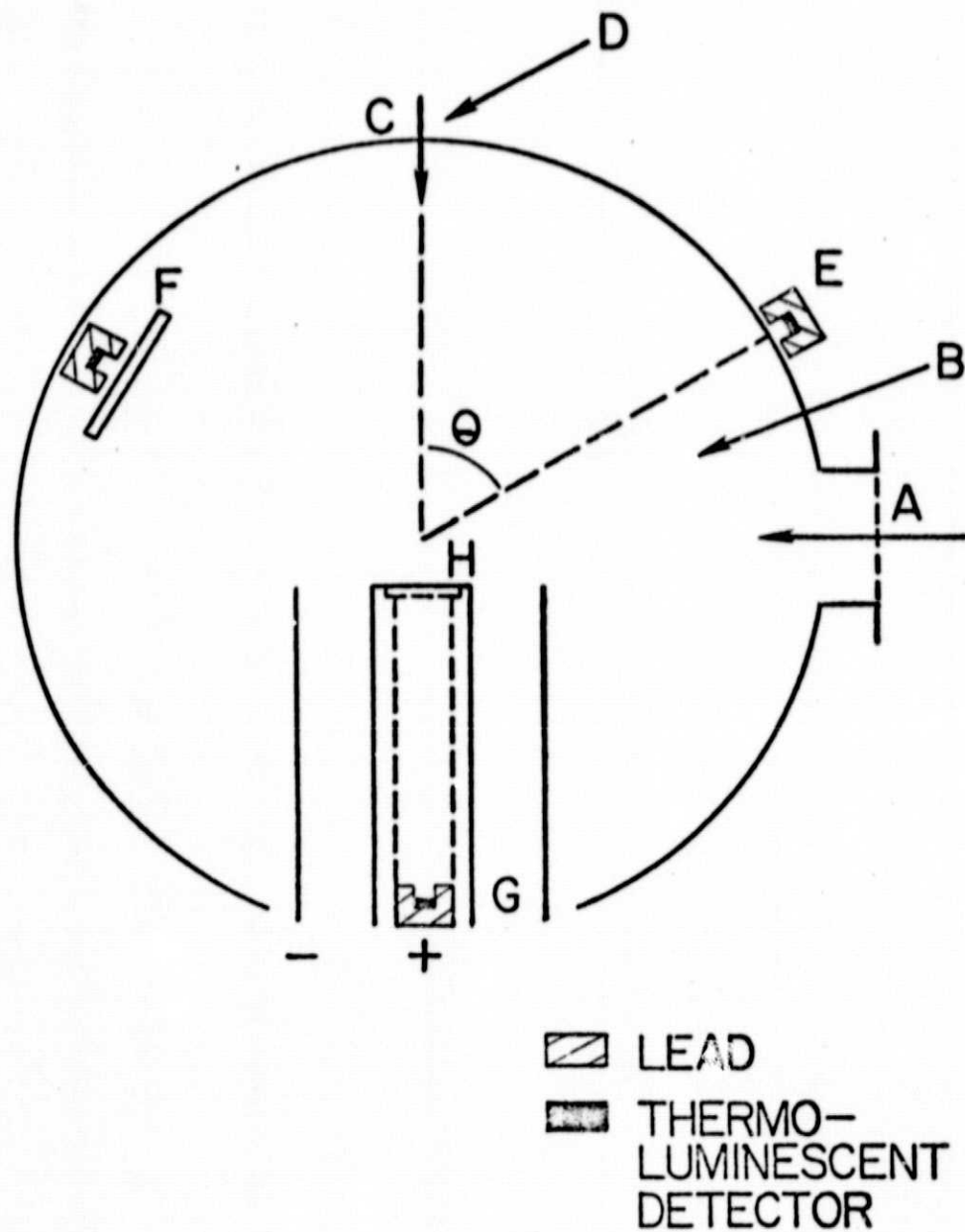

Fig. 1.- Experimental Arrangement. Pinhole cameras observed the plasma through 250 μm beryllium window, A, and through the aluminum vessel at B and C. Camera at D observed the vessel on axis. The thermoluminescent detectors, E, were placed outside the vessel at different θ , and also inside the vacuum system, behind a copper shield at F, and in the hollow anode at G. The anode cap H was interchangeable.

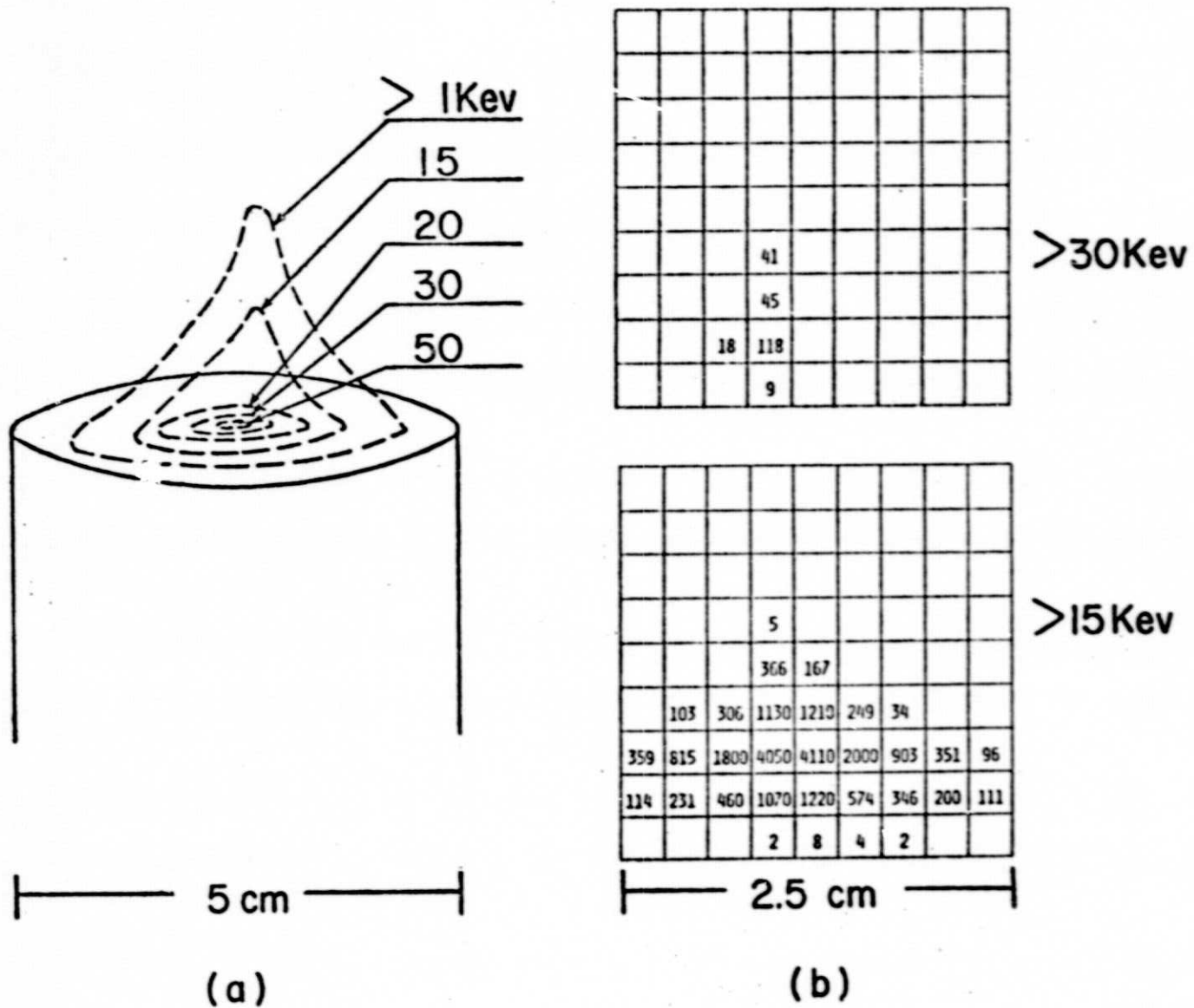

Fig. 2.- Summary of pinhole results: (a) with intensifier screen-polaroid film combination, (b) readings proportional to x-ray intensity from TLD rasters.

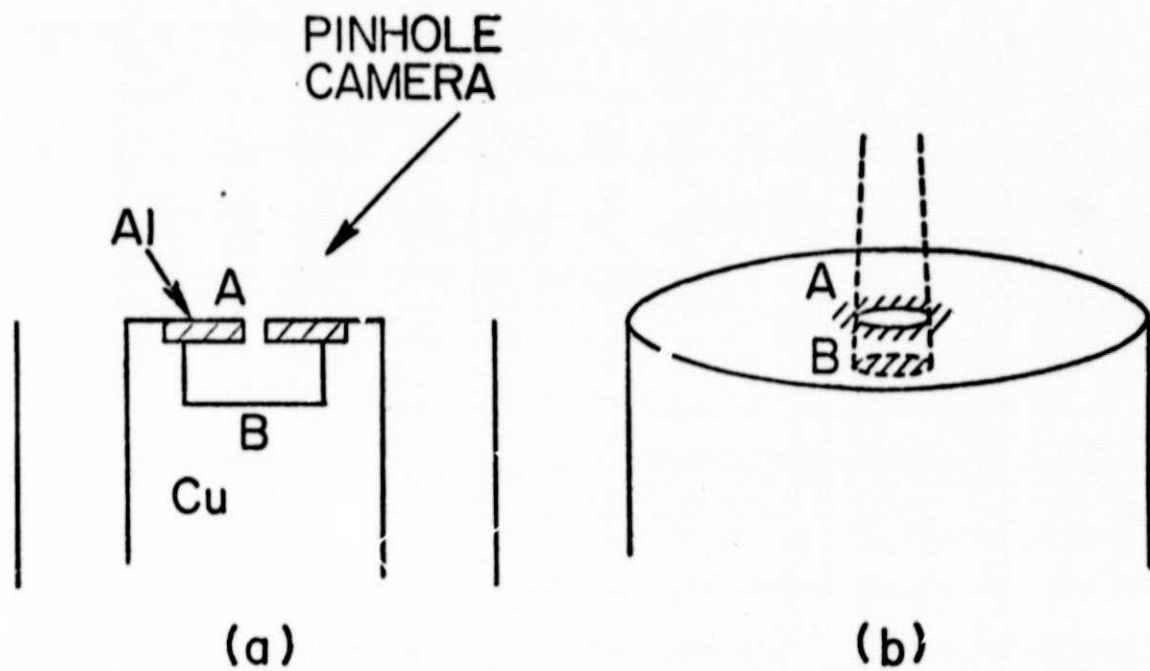

Fig. 3.- Method of determining high energy electron trajectories from x rays emitted: (a) structure of anode (b) view observed by pinhole camera; x rays are emitted from surfaces A and B, showing the electron trajectories are almost perpendicular to the anode surface.

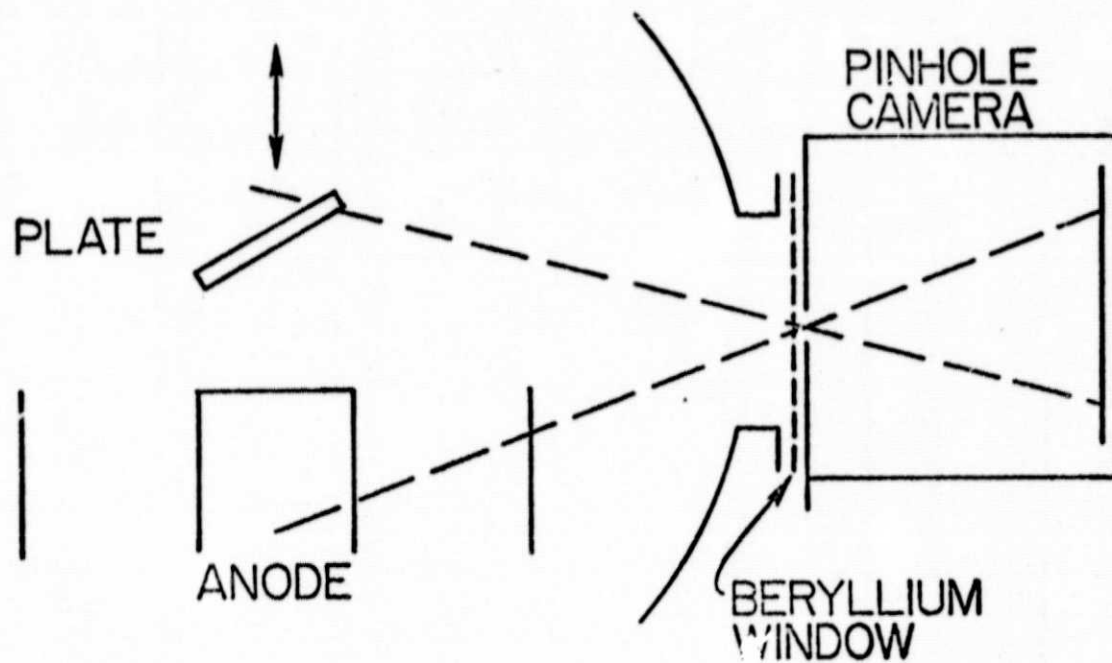

Fig. 4.- Arrangement for detecting high energy electrons traveling away from the anode. The aluminum plate was supported by an insulator from above. No x-ray emission from its lower surface was evident.

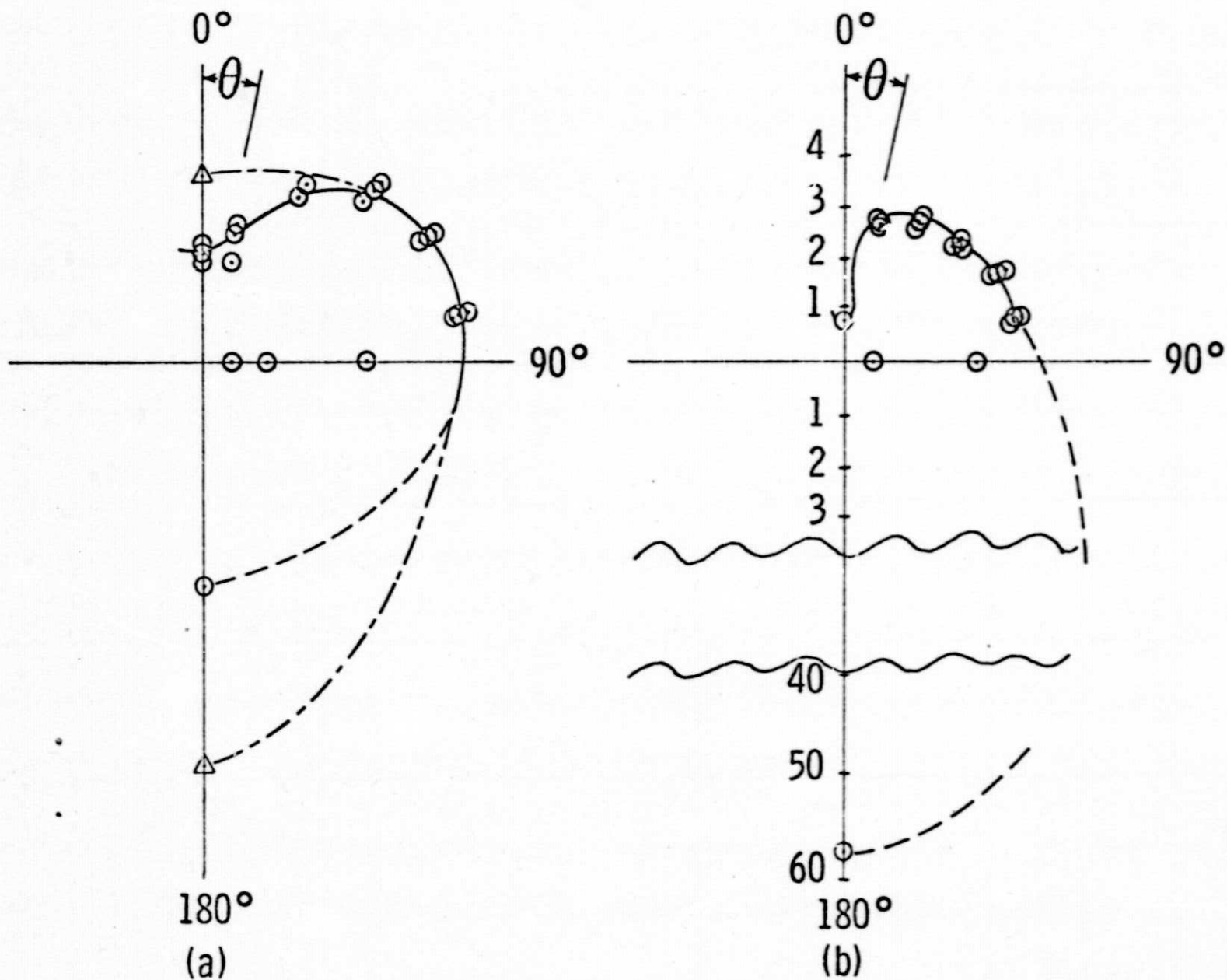

Fig. 5.- Polar diagrams of x ray intensity: (a) Medium energy x rays; θ aluminum cap corresponding to > 15 keV, A copper cap corresponding to > 30 keV, (b) x rays > 50 keV, aluminum cap. The scale is arbitrary.

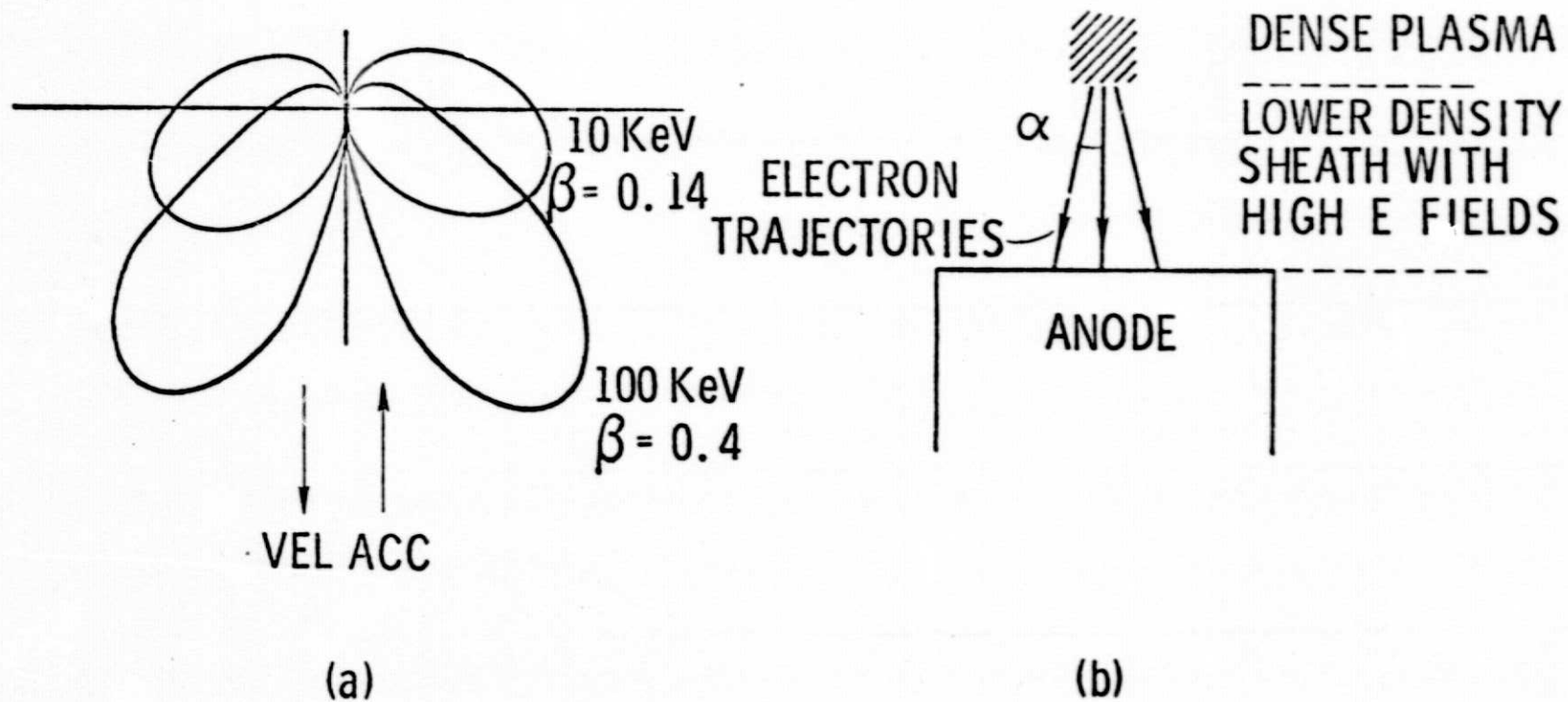

Fig. 6.- (a) Radiation pattern from a single electron.
 (b) Electron trajectories and electric field configuration.

APPENDIX B

Detection of Ion Trajectories

The purpose of this experiment was to detect ions moving away from the anode, and if possible estimate their velocities.

Several methods were tried but all were unsuccessful. First, an aluminum plate insulated from the vessel was placed on axis and connected by cable to a 50 Ω resistor across the input of an oscilloscope. The ion flux should generate a positive voltage signal on the plate. Unfortunately, the signal was buried in noise, although double shielding was used. A teflon cylinder 15 cm long was then placed between the vessel and the plate, to remove the plate from the region of strong electrical noise, but any signal was still undetectable, even using differential amplifier methods.

Next, several Rogowski coils were constructed that should have detected any ion current travelling to the plate through the teflon cylinder. The coils were connected to differential amplifiers and made symmetrical so that the noise picked up would cancel. The system was double shielded, but the signals could still not be detected. In addition, a balanced, ferrite core transformer feeding a differential amplifier was constructed, with a flat response up to 20 Mc, but this also failed to detect any signal.

The failure to detect any signal may possibly be caused by the space charge of the ions being cancelled out by electrons, dragged with them.

APPENDIX C

Spatial Distribution of Neutron Emission

An attempt was made to determine the spatial distribution of neutrons by using a collimator similar in cross section to the one shown in Fig. 1 of Appendix D. It was made of boron filled polyethylene, and had a two dimensional array of 1 mm diameter holes spaced 2.54 mm apart. The collimator was 15 cm thick and observed neutrons from the focus through the 2 mm aluminum vacuum vessel. A 254 μ m lead shield reduced the x-ray flux. The neutrons were detected by two methods (a) by rods of NE102 scintillator placed in the holes and in contact with 3000ASA film, and (b) by using a 4 x 24 raster of Type 600 thermoluminescent detectors which should detect neutrons. After a run of 50 focuses no definite pattern was evident on the film. The scintillator rods were then removed and the TLD's positioned. Previous estimates showed that about 500 focuses should give reasonable signals, and a total of 532 were superimposed over a period of weeks. However, no firm conclusions could be drawn from the experiment.

APPENDIX D

Emission of X rays from a Plasma Focus vs Position on a Fast Time-Scale

The purpose of these experiments was to record the emission of x rays from a plasma focus as a function of position and time, on a much faster time scale than hitherto. The observations would be important in determining the mechanisms of the focus.

The method consisted in using detectors that would convert the x ray energy into visible light and then observing the light with a fast electronic camera in the streak and framing mode.

Two types of detectors were used namely NE102 scintillator, and Du Pont Chronex Lightning Image intensifier screen.

The output from the NE102 had rise and decay times of a few ns, and the scintillator would be the most desirable material for fast time scales. The output increased with absorbing thickness, and the maximum thickness used was 7.5 cm. In all our experiments, even for x rays down to 1 KeV, the light output proved inadequate. For the maximum thickness the scintillator material was in the form of thin rods placed in a lead collimator. The ends of the rods were observed with an F2 lens, some 50 cm away. A factor of about 100 gain could have been achieved if the ends of the rods had been placed adjacent to the photocathode of the camera, but this involved modifying the electrical shielding of the apparatus and was not done.

The Du Pont image intensifying screen had a higher intensity light output than the scintillator. The output has a rise time of a few ns but a decay time of several μ s, so the results can only be used in the formation stage of a focus.

The electronic camera was an Imacon type, placed in series with an Imacon image intensifier with a gain of 50,000. The output was recorded on Polaroid 1000 ASA film. The camera-intensifier combination were claimed to have ps resolution. At the end of January 1976, the camera broke down, and was replaced with a TRW500 with even higher gain. The TRW-imacon intensifier combination worked well in the streak mode, but was unsatisfactory for framing, as only two frames could be recorded. Therefore our main results are in the streak mode using a Du Pont Chronex screen for a detector, although framing shots were also recorded. Observations were also made on visible light emission.

The experimental arrangement for streak photographs is shown in Fig. 1. A lead collimator was constructed with a single vertical line of holes of 1 mm diameter and 2.54 mm apart and placed opposite window A. The window allowed a vertical field of view of approximately 4 cm. The near end of the collimator was about 15 cm from the focus, so the holes could resolve adequately.

Visible light was recorded with window A of quartz and detector B of ground glass. Two crossed polaroids were introduced

between A and the collimator to reduce the light intensity. X rays of energy greater than 1 KeV were recorded with window A of 254 μm of Beryllium and detector B of Du Pont image intensifying screen. Finally x rays of greater than 20 KeV were recorded by interposing a lead filter of 100 μm thickness between A and the collimator in addition. These x rays had energies greater than would have been obtained by direct acceleration of the electrons by the voltage of the capacitor bank. Attempts to record energies higher than 20 KeV by using thicker filters reduced the signal to below noise level.

At the same time as the streak photographs were recorded, a time integrated picture of the low energy x rays was recorded through window C by a pinhole camera observing through 254 μm of Beryllium.

The results are summarized in Fig. 2. The pinhole image for x rays > 1 KeV is shown in (a). The streak results are summarized in (b), where the vertical line of holes coincided with PQ in (a). The region under the curves represents the area illuminated on the film. The curves in (b) have been idealized.

The visible light streaks (curve A) showed wide variations in behavior. The rise times varied from a few ns to about 1 μsec , corresponding to dotted curves A and B. A "plume" C was noticeable in some discharges. Curve D for x rays > 1 KeV showed a longer rise time. The curve has been smoothed and steps were observed for some focuses; nevertheless the rise time was about 1 μs .

Data taken through the lead filter corresponding to energies > 20 KeV have been idealized in curve E. Our results only recorded x rays of this energy for a small distance above the anode surface. The height of the illuminated section PQ was about 2 cm.

The observation that the higher energy x rays came from near the anode surface is in accord with time integrated pinhole pictures (Appendix A, Fig. 2). The new information here is that the emission of higher energy x rays occurred first from near the anode surface and afterwards from near the dense focus region. This suggests the emission of the x rays was by collisions of electrons with copper atoms or ions. The x-ray intensity should be proportional to Z^2 where $Z = 29$ is the atomic number of copper and the streaks should show regions of density of copper, rather than information on electron energies.

If so the slopes of the curves might yield the speed of the copper particles arose from the surface. The velocities from curves B, D and E are of order 10^4 m/s. A neutral copper atom of this velocity would possess an energy of 15 eV corresponding to a temperature of around $150,000^\circ$ - much too high for direct vaporation from the surface. The copper atoms and/or ions were probably heated by collisions from the plasma ions.

Framing pictures were also taken by replacing the

collimator in Fig. 1 with a lead pinhole camera, and using the same window and detectors. The pictures confirmed the time integrated pinhole results, but should be repeated with the Imacon camera which gives up to 16 frames per shot.

In conclusion, the x-ray streak method has worked successfully at least for x rays of energy higher than the bank voltage of the plasma focus.

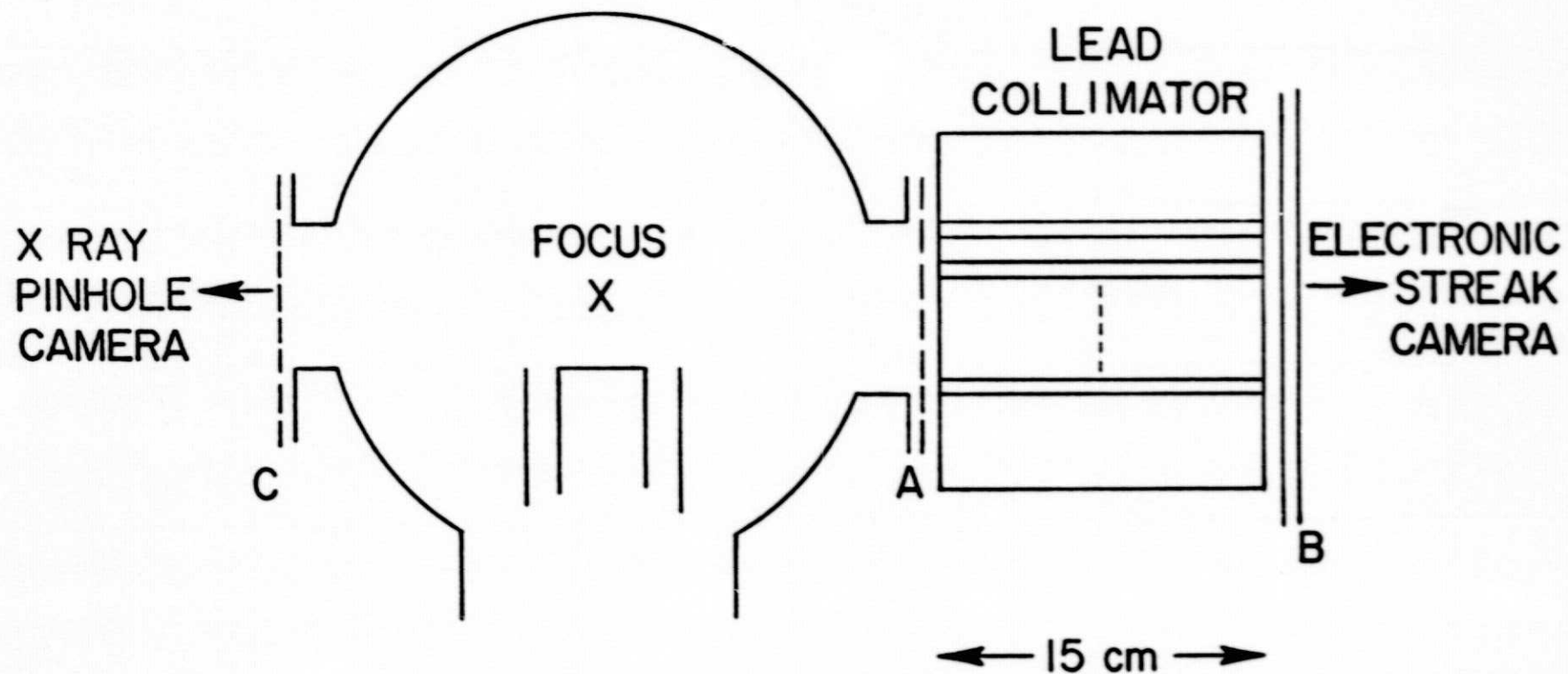

Fig. 1. Arrangement for streak photographs. When observing visible light, window A was quartz and detector B of ground glass. For x rays, A was 254- μm -thick beryllium, and B an image intensifier screen.

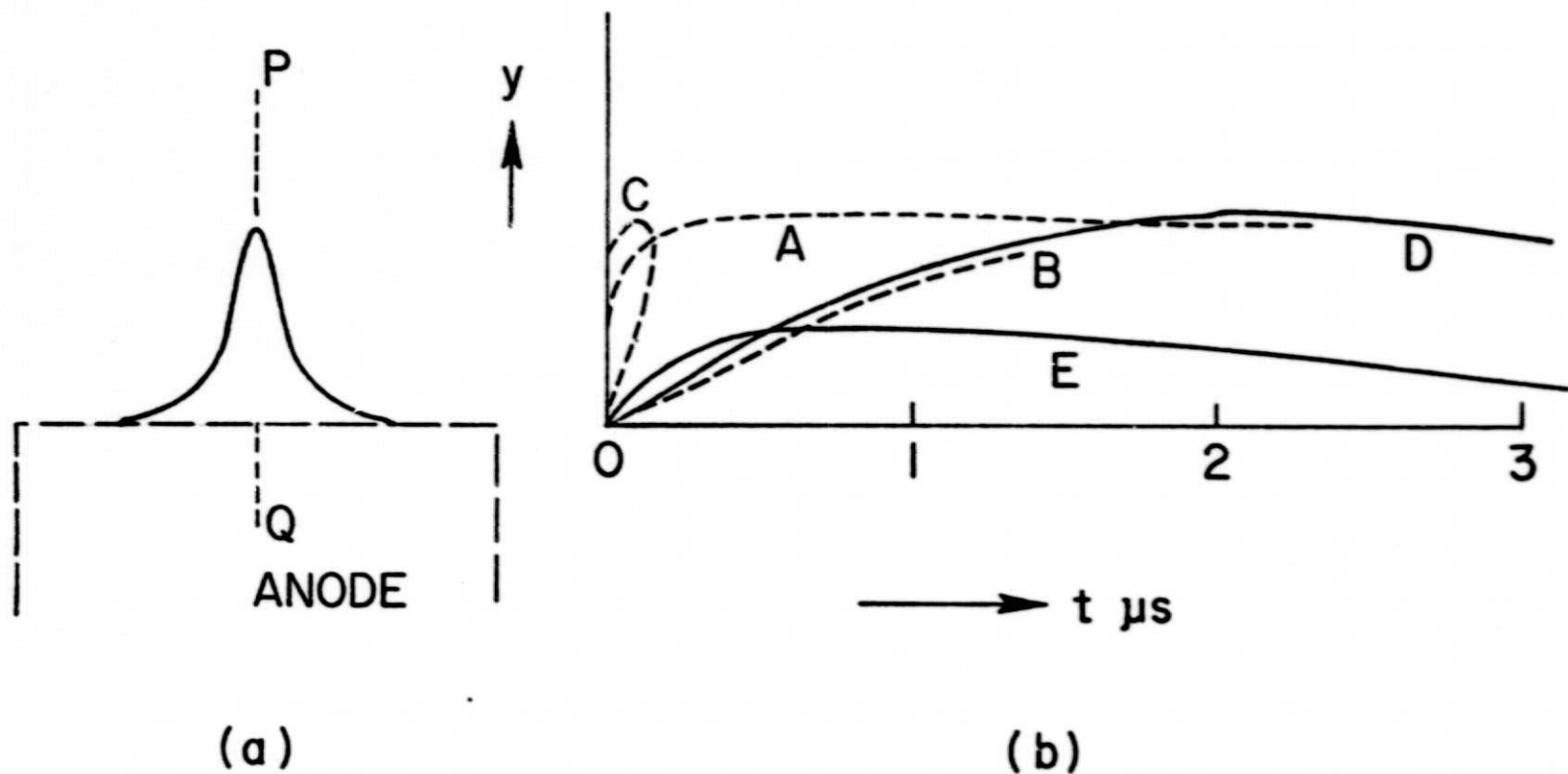

Fig. 2. Summary of results: (a) typical pinhole image of x rays > 1 KeV. (b) Idealized streak pictures taken along section PQ. The vertical scale is the same in both cases. Visible light streaks varied between A and B, and sometimes a plume C occurred. Curve D is for x rays > 1 KeV, and E for x rays > 20 KeV.