

General Disclaimer

One or more of the Following Statements may affect this Document

- This document has been reproduced from the best copy furnished by the organizational source. It is being released in the interest of making available as much information as possible.
- This document may contain data, which exceeds the sheet parameters. It was furnished in this condition by the organizational source and is the best copy available.
- This document may contain tone-on-tone or color graphs, charts and/or pictures, which have been reproduced in black and white.
- This document is paginated as submitted by the original source.
- Portions of this document are not fully legible due to the historical nature of some of the material. However, it is the best reproduction available from the original submission.

NASA CR-144773

SNOWPACK GROUND TRUTH

RADAR TEST SITE
STEAMBOAT SPRINGS, COLORADO

April 8-16, 1976

(NASA-CR-144773) SNOWPACK GROUND TRUTH: N76-28633
RADAR TEST SITE, STEAMBOAT SPRINGS,
COLORADO, 8-16 APRIL 1976 (Bittinger (M. W.)
and Associates, Inc.) 30 p HC \$4.00 Unclas
CSCL 08L G3/43 48574

Steven Howell
E. Bruce Jones
Charles F. Leaf

M. W. Bittinger & Associates, Inc.
P. O. Box Q
Fort Collins, Colorado 80522

April 1976
Mission Report--April 8-16, 1976, Mission

Prepared for:

GCDDARD SPACE FLIGHT CENTER
Greenbelt, Maryland 20771
Contract No. NAS5-22312



TABLE OF CONTENTS

	<u>Page</u>
INTRODUCTION	1
SITE DESCRIPTION AND GROUND-TRUTH SCOPE.	1
GROUND-TRUTH DATA.	2
DISCUSSION OF DATA	22
Daily Variation of Free-Water Content in Surface Snow Layer and Air Temperatures.	22
REFERENCES	26

LIST OF FIGURES

1. General location map of testing site	3
2. Detail location map of testing site.	4
3. Sketch plan of snow and soil sample sites.	5
4. Daily variation of free-water content in surface snow layer and air temperature, 4/9/76	23
5. Daily variation of free-water content in surface snow layer and air temperatures, 4/11/76	24
6. Daily variation of free-water content in surface snow layer and air temperatures, 4/13/76	25

LIST OF TABLES

	<u>Page</u>
1. Snowpack Data, 4/8/76.	6
2. Pit Descriptions, 4/8/76	6
3. Snowpack Data, 4/9/76.	8
4. Pit Descriptions, 4/9/76	9
5. Snowpack Data, 4/10/76	10
6. Pit Descriptions, 4/10/76.	11
7. Snowpack Data, 4/11/76	12
8. Pit Descriptions, 4/11/76.	12
9. Snowpack Data, 4/12/76	13
10. Pit Descriptions, 4/12/76.	13
11. Snowpack Data, 4/13/76	14
12. Pit Descriptions, 4/13/76.	15
13. Snow Temperatures, 4/13/76	16
14. Snowpack Data, 4/14/76	17
15. Pit 9 Snow Depth - Snow Temperatures, 4/14/76.	18
16. Crust Melt Data--Pit 9, 4/14/76.	18
17. Snowpack Data, 4/15/76	19
18. Snowpack Data, 4/16/76	19
19. USDA Soil Conservation Service Data.	20
20. Soil Moisture Sampling	21

SNOWPACK GROUND TRUTH
RADAR TEST SITE
STEAMBOAT SPRINGS, COLORADO
April 8-16, 1976, Mission

INTRODUCTION

This report contains the ground-truth data taken at Steamboat Springs, Colorado, in support of the NASA, USAF, and Georgia Institute of Technology mission in this area during the period April 8, 1976, through April 16, 1976. These data were taken by M. W. Bittinger & Associates, Inc., personnel with assistance from James Foster, NASA-GSFC, and USDA Soil Conservation Service personnel from the Steamboat Springs, Colorado, office.

SITE DESCRIPTION AND GROUND-TRUTH SCOPE

The location of the Steamboat Springs site used in this mission is shown in a general location map in Figure 1 and in detail in Figure 2. This area is located in the Yampa River Valley approximately 7 miles (11 km) south of the town of Steamboat Springs, Colorado. Data taken during this period included the following:

- (1) Snow depths and densities at selected locations (using a Mount Rose snow tube).
- (2) Snow pits for temperature, density, and liquid water determinations using the freezing calorimetry technique (Leaf 1966) and vertical layer classification (Sommerfeld 1969).
- (3) Snow walls were also constructed of various cross sections and documented with respect to sizes and snow characteristics.
- (4) Soil moisture at selected locations.
- (5) Appropriate air temperature and weather data.

The approach followed in taking this ground truth was to be responsive to the specific daily needs of the mission. These specific daily needs were set forth in a meeting each evening which involved all of the mission participants. Since ground-truth requirements varied each day, the data presented in this report are also on a day-by-day basis. Figure 3 shows the detailed location of specific points sampled throughout the entire mission.

Initially, eight snow sampling pits were excavated for the testing (see Figure 3). Due to the similarity of the snowpack characteristics in the area, it was decided the snow sampling would be confined to only two pits. Pits #1 and #5 became the primary sampling points and data collection was restricted to these points. Pit #5 was abandoned on 4/11/76 due to rapid snowmelt and the formation of a water layer in the bottom of the pit. Sampling of the snow was then confined to pit #1 until 4/14/76 when the snowpack became very shallow. Pit #9 was excavated the morning of 4/14/76 on a hillside (see Figures 2 and 3) where the snowpack was more substantial. Pit #9 was sampled for one day until it was abandoned also due to rapid snowmelt. The overall snowpack of the test site was insufficient for further sampling on 4/15/76 and 4/16/76; therefore attention was concentrated on artificially constructed snow-test banks and soil-moisture sampling.

GROUND-TRUTH DATA

The data on the liquid-water and other characteristics of the snowpack, as well as descriptions of the snow pits, are presented on a day-by-day basis in Tables 1-18. The specific data taken each day were dependent upon the demands of the experiment being performed by the radar. Table 19 contains the data taken by USDA Soil Conservation Service on the snowpack density. In addition to these measurements, some selected soil moistures were obtained and are presented in Table 20.

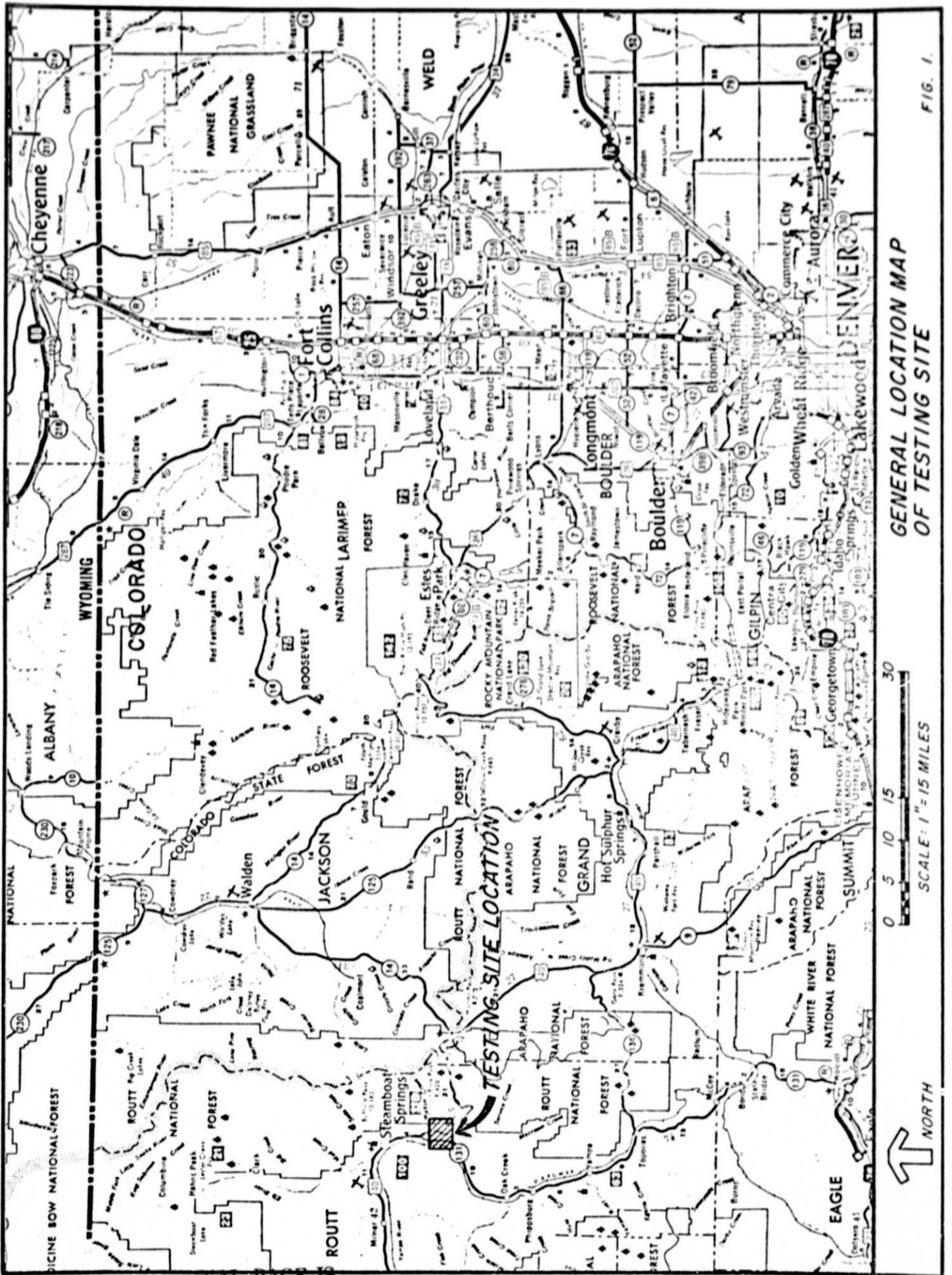

GENERAL LOCATION MAP
OF TESTING SITE

FIG. 1

ORIGINAL PAGE IS
OF POOR QUALITY

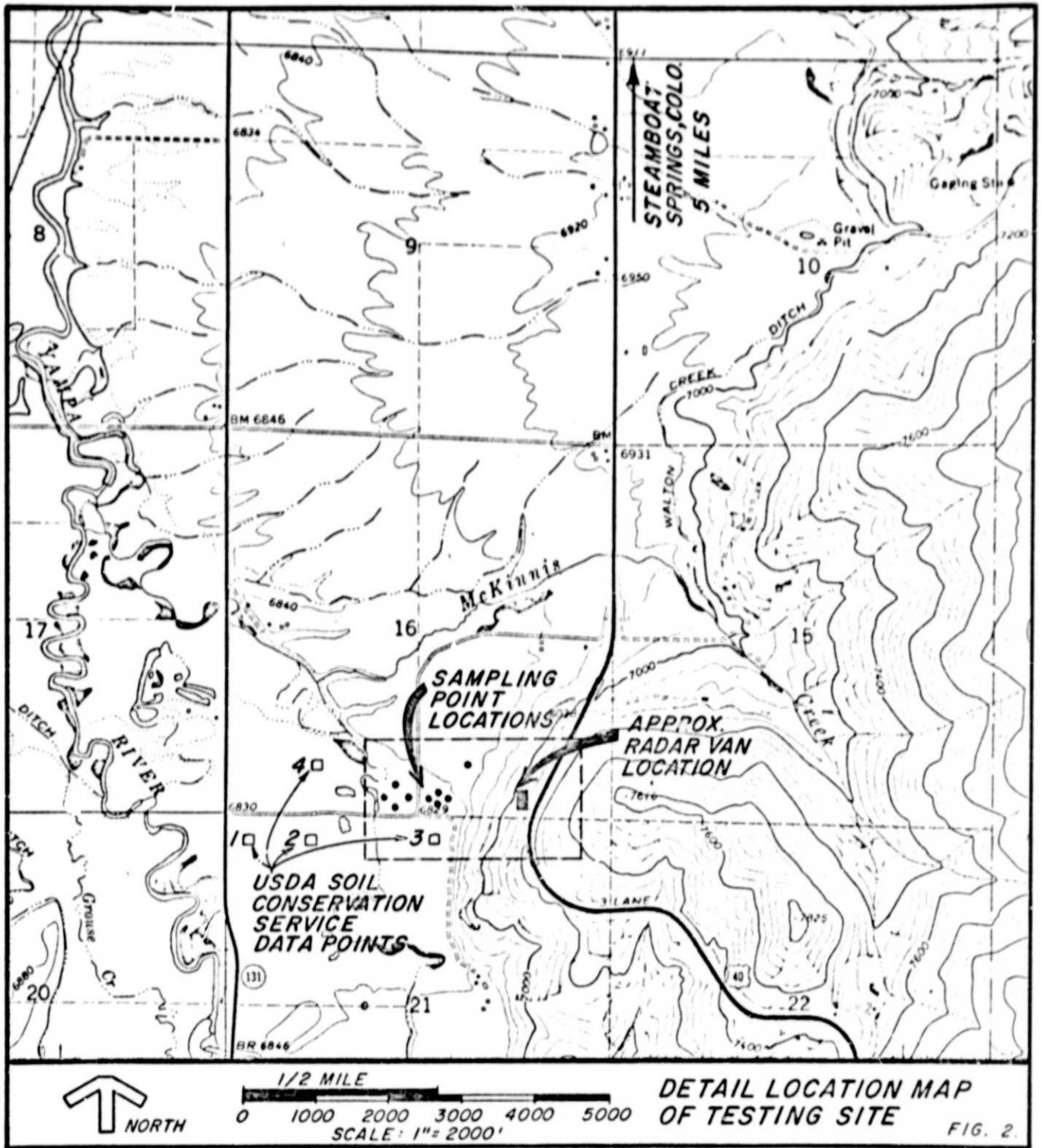

THE TEST SITE IS LOCATED IN THE SOUTH 1/2 OF SECTION 16 AND THE NORTH 1/2 OF SECTION 21, TOWNSHIP 5 NORTH, RANGE 84 WEST OF THE 61^h P.M., ROUTT COUNTY, COLORADO.

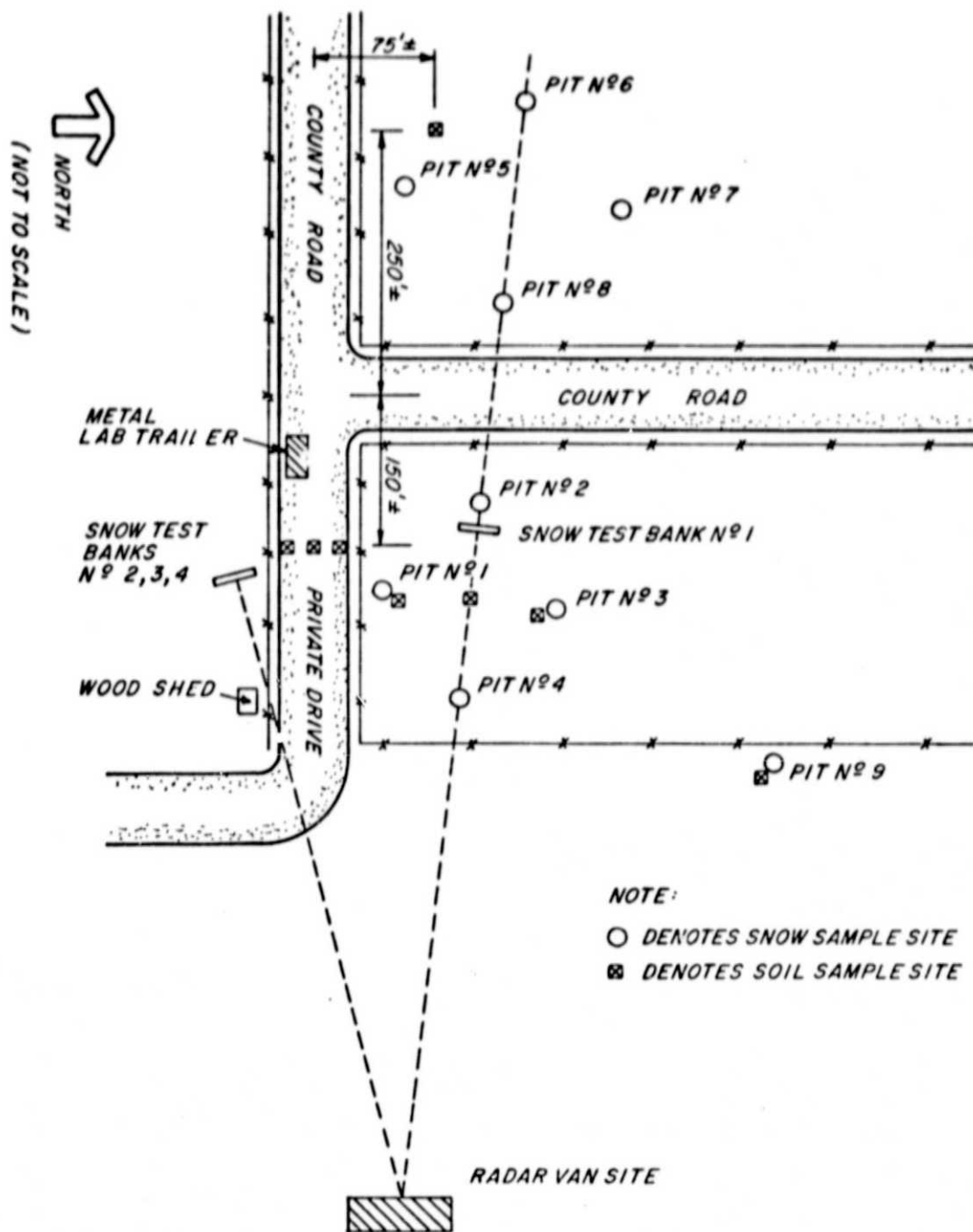

SKETCH PLAN OF SNOW AND SOIL SAMPLE SITES

Pits No. 1, 5, and 9 were the primary sampling points. The area around Pits No. 1 and No. 5 is a subirrigated, native grassland with various willow-lined tributary channels running through the area. These test areas are relatively flat except for the many small runoff and old stream channels. The area around Pit No. 9 is a native grass field which slopes to the west at a slight grade.

FIG. 3

Thursday
4/8/76

Table 1. Snowpack Data

Time	Air temp. (°C)	Pit No. 1				Pit No. 5				Remarks
		Free-water (%)		Density (Kg/m ³)		Free-water (%)		Density (Kg/m ³)		
		Top	Bottom	Top	Bottom	Top	Bottom	Top	Bottom	
1000	+1									Snow depth 15"
1030	+3			268						
1100	+7	5.3	3.0							
1130	+7							324	406	
1200	+5									
1415	+7	31.4		410						
1430	+11									
1500	+13		11.3							
1530	+14									
1600	+11	27.9				34.9		390		
1610	+12									
1630	+8						23.5			
1700	+10	23.6				34.5				
1730	+6									
1800	+7									

Table 2. Pit Descriptions

Pit No. 1 - Time 1045 - Total snow depth 15" - Air temp. +5°C

Depth to bottom of layer	Thickness of layer	Snow classification	Grain size	Layer temp. (°C)	Density (Kg/m ³)	Remarks
15"	8"	Well developed depth hoar	2mm diam. average	0°	438	Wet pack throughout
7"	4½"	Metamorphosed old snow-melt-crust	2mm + sintering	0°	366	Advanced melt-freeze metamorphism
2½"	2½"	New snow--wet	1-1½mm ave. diam.	0°	268	

Thursday
4/8/76

Table 2. Pit Descriptions (continued)

Pit No. 5 - Time 1130 - Total snow depth 15" - Air temp. +7°C

Depth to bottom of layer	Thickness of layer	Snow classification	Grain size	Layer temp. (°C)	Density (Kg/m ³)	Remarks
15"	8½"	Well developed depth hoar	2mm diam. average	0°	406	5" of water formed in bottom while pit was dug
6½"	4"	Metamorphosed old snow-melt-crust	2mm + sintering	0°	412	Advanced melt-freeze metamorphism
2½"	2½"	New snow-wet	1-1½mm ave. diam.	0°	324	

Friday
4/9/76

Table 3. Snowpack Data

Time	Air temp. (°C)	Pit No. 1				Pit No. 5				Remarks
		Free-water (%)		Density (Kg/m ³)		Free-water (%)		Density (Kg/m ³)		
		Top	Bottom	Top	Bottom	Top	Bottom	Top	Bottom	
0715	+3	5.6		346	402					Snow depth 13½" both pits
0800	+2							350	418	
0830	+4					1-3				
0900	+8									
1000	+10									
1030	+13	23		418						
1100	+15					24.0		350		
1130	+15									
1200	+14									
1230										
1300										
1330	+13					23.9		348		
1400	+14	22.5		328						Snow depth 12" pit #1 Snow depth 11" pit #5
1430	+11									
1500	+11	16.3		328		9.7*(1450)		454*		*Snow test bank No. 1-down range
1530	+10					21.8		326		Snow depth 11½" pit #1 Snow depth 10½" pit #5
1600	+11									
1630	+10					13.3*(1630)		484*		*Snow test bank No. 1-down range
1700	+9					11.9*(1630)		494*		*Snow test bank No. 1-up range
1730	+8	17.3		352						
1800	+8									

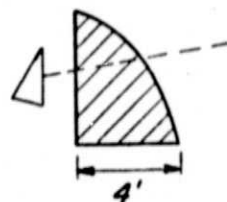
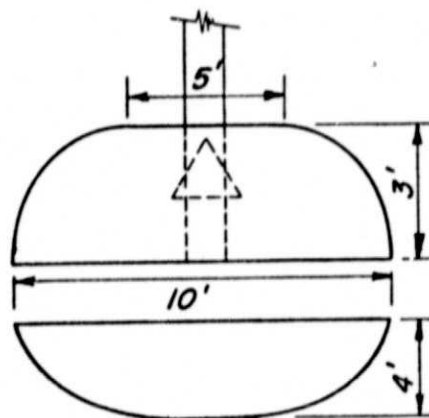

Note:
Snow samples taken
at point 1'± from
top of bank.

SNOW TEST BANK N^o 1

Friday
4/9/76

Table 4. Pit Descriptions

Pit No. 1 - Time 0715 - Total snow depth 13-1/2" - Air temp. +3°C

Depth to bottom of layer	Thickness of layer	Snow classification	Grain size	Layer temp. (°C)	Density (Kg/m ³)	Remarks
13½"	8"	Well developed depth hoar	2mm diam. average	0°	402	
5½"	4"	Metamorphosed old snow-melt-crust	2mm ave.	-2°	388	
1½"	1½"	New snow melt-freeze	1 mm ave. ½-1½mm range	-7°	346	

Pit No. 5 - Time 0730 - Total snow depth 13-1/2" - Air temp. +3°C

Depth to bottom of layer	Thickness of layer	Snow classification	Grain size	Layer temp. (°C)	Density (Kg/m ³)	Remarks
13½"	7½"	Well developed depth hoar	2mm ave.	0°		6" of water in bottom of pit
6"	4½"	Metamorphosed old snow melt-crust	2mm ave.	-2°	418	
1½"	1½"	New snow melt-freeze	1mm ave.	-5°	356	

Saturday
4/10/76

Table 6. Pit Descriptions

Pit No. 1 - Time 0745 - Total snow depth 11-1/2" - Air temp. 0°C

Depth to bottom of layer	Thickness of layer	Snow classification	Grain size	Layer temp. (°C)	Density (Kg/m ³)	Remarks
11 1/2"	6 1/2"	Well developed depth hoar	1-2mm+ 2mm ave.	0°	404	
5"	3"	Melt-freeze metamorphism	1-2mm+ 2mm ave.	-4°	360	

Pit No. 5 - Time 0730 - Total snow depth 9" - Air temp. -1°C

Depth to bottom of layer	Thickness of layer	Snow classification	Grain size	Layer temp. (°C)	Density (Kg/m ³)	Remarks
9"	4 1/2"	Well developed depth hoar	2mm ave.	0°	Unable to sample due to water	4 " of water in pit bottom
4 1/2"	4 1/2"	Melt-freeze metamorphism	1-2mm 2mm ave.	-4°	376	

Table 7. Snowpack DataSunday
4/11/76

Time	Temp. (0°C)		Pit No. 1 ^{1/}				Remarks
			Free water (%)		Density (Kg/m ³)		
			Shade	Sun	Top	Bottom	
0700	-5		<1	3.2	360	364	Snow depth 10½"-11"
0800		+2	1-3		350		
0830	+1	+6	1-3				
0900	+3	+6	1-3		350		
0930	+5	+10		13.5	376	356	
1000	+7	+13	9.4		352		
1030	+8	+12	12.6				
1100	+9	+12	11.2		310		
1130	+10	+16	15.4				
1200	+10	+20	12.0	14.1	350	382	Snow depth 9"
1230	+11	+20					
1300	+14	+21	17.2		346		
1330	+13	+17	17.8				Cloud cover
1400	+12	+13	14.6	14.3	364	386	Snow depth 8"

^{1/} Pit No. 5 abandoned.Table 8. Pit Description

Pit No. 1 - Time 0645 - Total snow depth 10½"-11" - Air temp. -5°C

Depth to bottom of layer	Thickness of layer	Snow classification	Grain size	Layer temp. (°C)	Density (Kg/m ³)	Remarks
10½"	7½"	Metamorphosed old snow	2mm+ ave.	0°	364	Unfrozen
3"	3"	Metamorphosed old snow	2mm+ ave.	-6°	360	Frozen crust

Table 9. Snowpack DataMonday
4/12/76

Time	Pit No. 1						Remarks
	Temp. (0°C)		Free water (%)		Density (Kg/m ³)		
	Shade	Sun	Top	Bottom	Top	Bottom	
0730	+4	+4	1-3	16.2			Snow depth 8"
0800	+5	+5			346	396	
0830	+4	+6					
0900							
0930	+6	+8	9.3		360		
1000	+8	+18	11.7		344		
1030	+11	+20		15.7			
1100	+14	+18	14.8		390	350	Snow depth 5½"-6"
1130	+17	+20	22.4				
1200	+15	+18	10.2		400		Cumulus clouds building
1230	+12	+10	23.6				Overcast
1300	+11	+12	20.3	15.7	380	330	Snow depth 5" gusty winds
1330	+14	+18					Sun out
1400	+14	+15	17.0		376		Overcast
1430	+12	+12	18.4				"
1500	+11	+10	14.6	16.5	342	350	"
1530	+8	+9					"
1600	+8	+9	14.1		346		"
1630	+8	+8	14.2				"
1700	+6	+7	15.8	18.9	320	420	Snow depth 4"-4½" overcast
1730	+6	+7					Rain falling

Table 10. Pit Description

Pit No. 1 - Time 0730 - Total snow depth 8" - Air Temp. +4°C

Depth to bottom of layer	Thickness of layer	Snow classification	Grain size	Layer temp. (°C)	Density (Kg/m ³)	Remarks
8"	4"	Metamorphosed old snow	2mm+ ave.	0°		Unfrozen
4"	4"	Metamorphosed old snow	2mm + ave.	-3°		Frozen crust

Tuesday
4/13/76

Table 11. Snowpack Data

Time	Temp. (0°C)		Pit No. 1				Remarks
	Shade	Sun	Free water (%)		Density (Kg/m ³)		
			Top	Bottom	Top	Bottom	
0600	-2						Rained evening of 4/12/76 Overcast sky - 80% Snow depth 3"-5"
0630	-2		<1	5	324	356	
0700	-1		<1		318		
0730	0		1-3				
0800	+1		1-3		316		
0815	+4						
0825	+2						
0830	+3		3	7.2			
0845	+3						
0900	+5		8.9		336	320	
0915	+4						
0930	+4		15.4				
0945	+4						
1000	+5		14.1		360		
1015	+6						
1030	+9		13.7	14.3			
1045	+11						
1100	+9		9.7		368	Overcast - 100%	
1115	+7						
1130	+5		7.4				
1145	+4						
1200	+3		8.7		352		
1215	+3						
1230	+3		10.3	8.2			
1245	+2						
1300	+5		18.2		380		
1330	+5		21.1				
1345	+5						
1400	+7		20.3		386		
1415	+6						
1430	+6		13.7				
1445	+7						
1500	+9		16.8		376		
1530	+10		17.7				
1600	+12		12.4		366	Snow depth 0"--3-3/4"	
1630	+11		17.7				

Tuesday
4/13/76

Table 12. Pit Description

Pit No. 1 - Time 0615 - Total snow depth 3"-5" - Air temp. -2°C

Depth to bottom of layer	Thickness of layer	Snow classification	Grain size	Layer temp. (°C)	Density (Kg/m ³)	Remarks
4"-5"	1"-2"	Metamorphosed old snow	2mm+ ave.	0°	356	Unfrozen
3"	3"	Metamorphosed old snow	2mm+ ave.	-2.5°	324	Frozen

Tuesday
4/13/76

Table 13. Snow Temperatures

Pit No. 1

Time	Air temp. (°C)	Temp. of surface snow (°C)	Temp. of snow 1" below surface (°C)	Remarks
0615	-2	-2.5	-1	80% of sky alto-cumulus
0630	-2	-2	-1	3"-5" snow depth
0642		-2	-1	
0645		0	0	
0700	-1	0	0	Partial overcast
0715		0	0	Sun obscured by clouds
0730	0	0	0	" " " "
0745		0	0	" " " "
0752		0	0	First sun breakthrough
0800	+1	0	0	Sun in and out of clouds
0815	+4	0	0	" " " " " "
0825	+2			
0830	+3	0	0	" " " " " "
0845	+3	0	0	" " " " " "
0900	+5	0	0	" " " " " "
0915	+4	0	0	90% overcast sky
0930	+4	0	0	Sun in and out of clouds
0945	+4	0	0	" " " " " "
1000	+5	0	0	Thin overcast
1015	+6	0	0	Sun out 15 minutes
1030	+9	0	0	Sun out weakly
1045	+11	0	0	Clouds building up
1100	+9	0	0	100% overcast
1115	+7	0	0	Light sleet falling
1130	+5	0	0	Same as above
1145	+4	0	0	Same as above
1200	+3	0	0	Same as above
1215	+3	0	0	100% overcast Light showers
1230	+3	0	0	100% overcast Light snow falling
1245	+2	0	0	Moderate snow falling
1250				Snow ended
1300	+5	0	0	Sun shining
1315		0	0	Sun and fog
1330	+5	0	0	" " "
1345	+5	0	0	" " "
1400	+7	0	0	" " "
1415	+6	0	0	Sunshining
1430	+6	0	0	Sun & scattered cumulus
1445	+7	0	0	" " " "
1500	+9	0	0	" " " "
1515		0	0	" " " "
1530	+10	0	0	" " " "
1600	+12	0	0	4"-0" snow depth

Wednesday
4/14/76

Table 14 Snowpack Data

Time	Temp. (0°C)		Free water (%)		Density (Kg/m ³)		Remarks
	Shade	Sun	Top	Bottom	Top	Bottom	
0700	+9		1-3	10.3	356		Snow depth 4"-6"
0715	+6						
0730	+4		1-3				
0800	+7		6.5		344		
0815	+4						
0830	+4		1-3				
0845	+6						
0900	+6		7.0	12.4	348		
0915	+7						
0930	+8		11.6				
0945	+8						
1000	+9		12.3		360		Snow depth 3"-5"
1015	+10	+18					
1030	+11		13.6				
1045	+10						
1100	+14		13.1		382		
1130	+14		15.1	25.9			Snow depth 2"-4"
1200	+14						
1230	+13		Snow test bank No. 2				
1300	+13		11.3		534		Begin first run
1330	+13						
1400	+10		11.7				End 1st run--start 2nd
1430	+9		12.1				End 2nd run--start 3rd
1500	+8		7.6				End 3rd run--start 4th
1530	+8		8.6				End 4th run--start 5th
1540	+8		13.3				End 5th run--start 6th
1550	+7		17.4				End 6th run--start 7th
1600	+7		7.2		516		End 7th run--collapsed

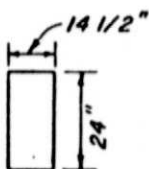

- 1st run--1.2' thick
- 2nd " 1.0' "
- 3rd " 0.7' "
- 4th " 0.5' "
- 5th " 0.3' "
- 6th " 0.2' "
- 7th " 0.1' "

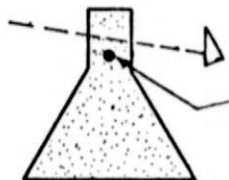

Sample area for 1st run
(successive samples taken
from snow scraped off wall)

SNOW TEST BANK N^o 2
(constructed by piling snow and then
scraping .1 to .3 feet off of thick-
ness for each run)

ORIGINAL PAGE IS
OF POOR QUALITY

Wednesday
4/14/76

Table 15.
Pit No. 9 - Snow depth 4"-6" - Snow temperatures

Time	Air temp. (°C)	Temp. of surface snow (°C)	Temp. of snow 1" below surface (°C)	Remarks
0700	+4	-0.5	0	Snow depth 4"-6" 2½" of frozen crust
0715	+6	0	0	15% alto-cumulus cloud cover
0717		0	0	Sun hits sampling point
0718		0	0	
0730	+4	0	0	Thin clouds shade sun
0745		0	0	Bright sun--no clouds
0800	+7	0	0	" " " "
0815	+4	0	0	" " " "
0830	+4	0	0	" " " "
0845	+6	0	0	
0900	+6	0	0	
0915	+7	0	0	
0930	+8	0	0	
0945	+8	0	0	
1000	+9	0	0	Snow depth 3"-5"
1015	+10	0	0	Cumulus clouds forming
1030	+11	0	0	
1045	+10	0	0	
1100	+14	0	0	
1115	+14	0	0	
1130	+14	0	0	Scattered clouds--gusty winds, snow depth 1"-4"

Table 16.
Crust melt data - Pit No. 9

Time	Snow crust condition
0700	Crust frozen--2"-2½" thick
0717	Sun hits top of crust
0800	Crust frozen but melt beginning to occur
0830	Due to irregular surface, the direct sun exposed areas have melted ¼" to ½" deep. The less exposed areas show little melt occurring.
0900	Total crust has melted ¼" to ½" deep. Direct sun exposed areas show up to 1" melt.
0915	Crust melt has reached ¾-1½" deep. 1" to 2" frozen layer remains under melted layer.
0945	Crust melt has reached 1-2" deep. 1" to 1½" frozen layer remains under melted layer.
1000	No definable frozen layer remains.

Thursday
4/15/76

Table 17. Snowpack Data

Snow Test Bank No. 3				
Time	Air temp. (°C)	Free water (%)	Density (Kg/m ³)	Remarks
0745	+7	1-3		Bank 0.15' wide
0800	+6			
0830	+4	10.7	340	Bank 0.05' wide--collapsed

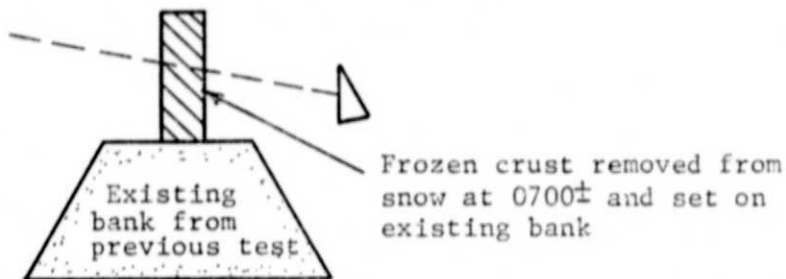

Table 18. Snowpack Data

Friday
4/16/76

Snow Test Bank No. 4				
Time	Air temp. (°C)	Free water (%)	Density (Kg/m ³)	Remarks
0630	+1	1-3	390	Bank 0.2' wide
0700	+1			
0845	+4	10.6	450	Bank 0.1' wide

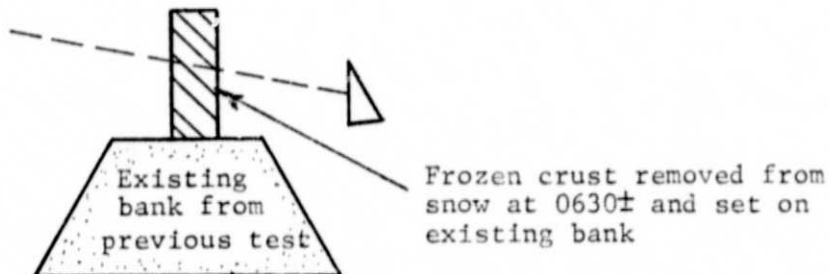

Table 19.
 USDA Soil Conservation Service Data
 (Data taken with Mount Rose snow tube)

Date	Time	SCS Data Point No. 1			SCS Data Point No. 2			SCS Data Point No. 3			SCS Data Point No. 4		
		Snow depth (in.)	Water content (in.)	Density (Kg/m ³)	Snow depth (in.)	Water content (in.)	Density (Kg/m ³)	Snow depth (in.)	Water content (in.)	Density (Kg/m ³)	Snow depth (in.)	Water content (in.)	Density (Kg/m ³)
4/8/76	0800	18.0	5.5	300	15.0	4.5	300	21	6.5	310	16.0	6.0	380
	1545	17.0	5.0	295	15.0	4.5	300	19	6.5	350	15.0	6.5	390
4/9/76	0800	17.0	6.0	355	14.0	4.0	290	19	10.0	530	15.0	5.0	335
	1530	15.0	6.0	400	13.0	5.0	380	17	6.5	400	14.0	7.0	500
4/10/76	0830	14.0	5.0	355	12.0	3.0	250	16	7.0	437	12.5	5.0	400
	1530	12.5	5.0	400	10.5	4.0	380	14	6.0	428	11.0	4.0	363
4/11/76	0900	12.0	3.5	290	10.5	4.0	380	14	5.0	360	10.5	5.0	470
	1500	10.5	3.5	330	9.0	3.0	330	13	5.0	380	unable to sample		
4/12/76	0800	10.0	3.0	330	8.0	2.5	330	11	4.0	420	9.0	3.0	330
	1530	9.0	4.0	430	7.0	2.0	290	9	4.0	430	7.0	3.0	430
4/13/76	0800	8.0	2.5	310	6.0	2.0	330	9	3.0	300	7.0	3.0	430
	1530	6.0	2.0	330	5.0	2.0	400	8	3.0	380	7.0	3.0	420
4/14/76	0830	5.0	2.0	400	5.0	2.0	400	8	3.0	340	5.5	2.0	370
	1545	unable to sample			unable to sample			6	1.5	250	4.0	1.5	370

Note: For location of data points see detailed location map of testing site (Fig. 2).

Table 20

Soil Moisture Sampling

<u>Time</u>	<u>Air temp.</u> (°C)	<u>Can No.</u>	<u>Tare weight</u> (g)	<u>Wet weight</u> (g)	<u>Dry weight</u> (g)	<u>Moisture content</u> (%)	<u>Location</u> (See Fig. 3 also)	<u>Remarks</u>	<u>Date</u>
1210	+14	38	39.2	170.0	147.5	20.8	N side of road 150' E of road intersec.	Silty-sandy gravel Roadbase - top 1/2"	4/12/76
1210	+14	25	38.1	168.0	142.9	24.2	S side of road " " " "	Same as above	
1212	+14	58	38.4	182.0	174.1	5.8	Centerline of road " " " "	Same as above	
1412	+10	3	38.6	128.8	85.2	93.6	Pit #1	Top 1/2" of surface slight drying-organic	4/15/76
1414	+10	31	38.4	136.0	100.3	57.7	Pit #3	Top 1/2" of ground Native grass cover	
1445	+9	22	39.3	204.1	195.8	5.3	Centerline of road 150' E of road intersec.	Silty-sandy gravel Roadbase - top 1/2"	
1447	+9	2	38.4	195.5	168.1	21.1	S side of road " " " "	Same as above	
1449	+9	55	39.1	171.4	155.0	14.2	N side of road " " " "	Same as above	
1515	+9	24	38.9	134.2	102.0	51.0	250' W x 75' N of road intersection	Top 1/2" of ground Pasture grass cover	4/16/76
1510	+7	44	38.4	163.8	107.4	81.7	Pit No. 9	Top 1/2" of ground	
1513	+7	20	37.8	141.4	113.0	37.8	Pit No. 1-4-center of site	Top 1/2" of ground Pasture grass cover	
1510	+7	59	38.3	123.0	97.4	43.3	250' W x 75' N of road intersection	Top 1/2" of ground Pasture grass cover	
1516	+7	15	38.4	190.4	180.3	7.2	Center of road	Silty-sandy gravel Roadbase-top 1/2"	

DISCUSSION OF DATA

Daily Variation of Free Water Content in Surface Snow Layer and Air Temperatures

Free-water content typically is very nearly synchronous with air temperature. The maximum amount of free water generated in the snowpack during a given snowmelt day also depends on texture. A fully ripened coarse-textured snowpack will retain less free water than a fine-textured snow. This is illustrated by Figures 4, 5, and 6, which show the time sequence of air temperature (as measured approximately 1.5 meters above the pack), crystalline structure, and free water in the top layer.

The highest liquid water contents of the surface snow layer during the testing period were observed during the days of 4/8/76 and 4/9/76 (Tables 1 and 3 and Figure 4). These higher levels of liquid water were caused by the "new" snow layer which existed during these days (Tables 2 and 4). The "new" snow layer was of a finer textured snow which has a higher liquid water retention characteristic. The maximum air temperatures were +14° to +15° C. with clear weather melt. The range of free water in the top snow layer was approximately 20 percent in both pits.

Melt-freeze metamorphism ripened the "new" surface snow layer into metamorphosed "old" snow by 4/11/76 (Table 8). The sub-zero C. temperatures during the nighttime hours resulted in a frozen crust forming on the top 4 inches of snow (Table 8). The crust layer had a temperature of <0°C. and consequently measured free-water content was less than 1.0 percent. Figure 5 shows the gradual increase in free water to be synchronous with the increase in air temperatures.

Figure 6 shows the responsiveness of free water in the surface layer of ripened snow to air temperature changes during the day of 4/13/76. Table 13 describes the meteorological data throughout this day. Periods of sunshine, overcast, and precipitation occurred throughout the day and are reflected in air temperature changes and free-water variations in the surface snow layer.

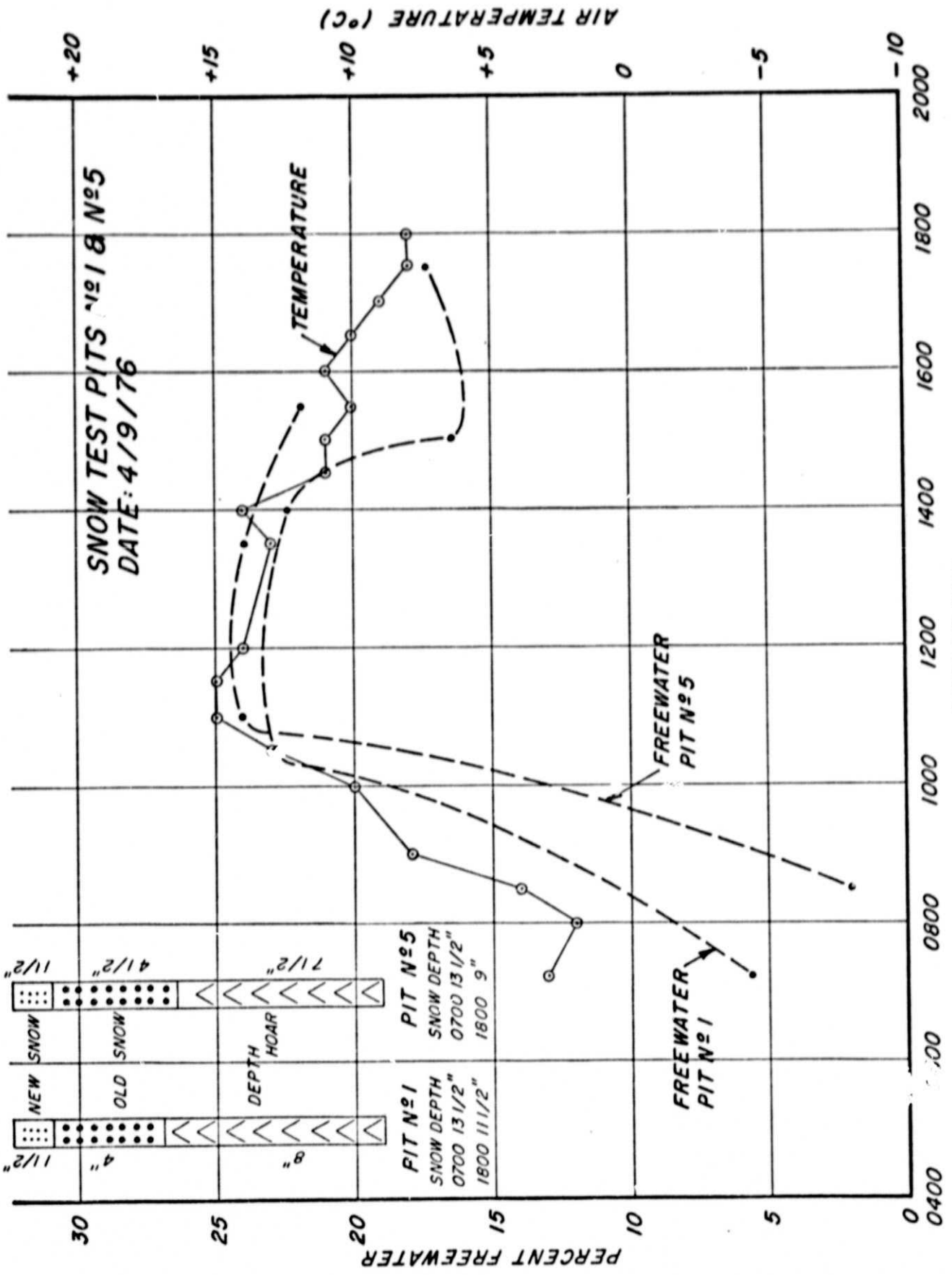
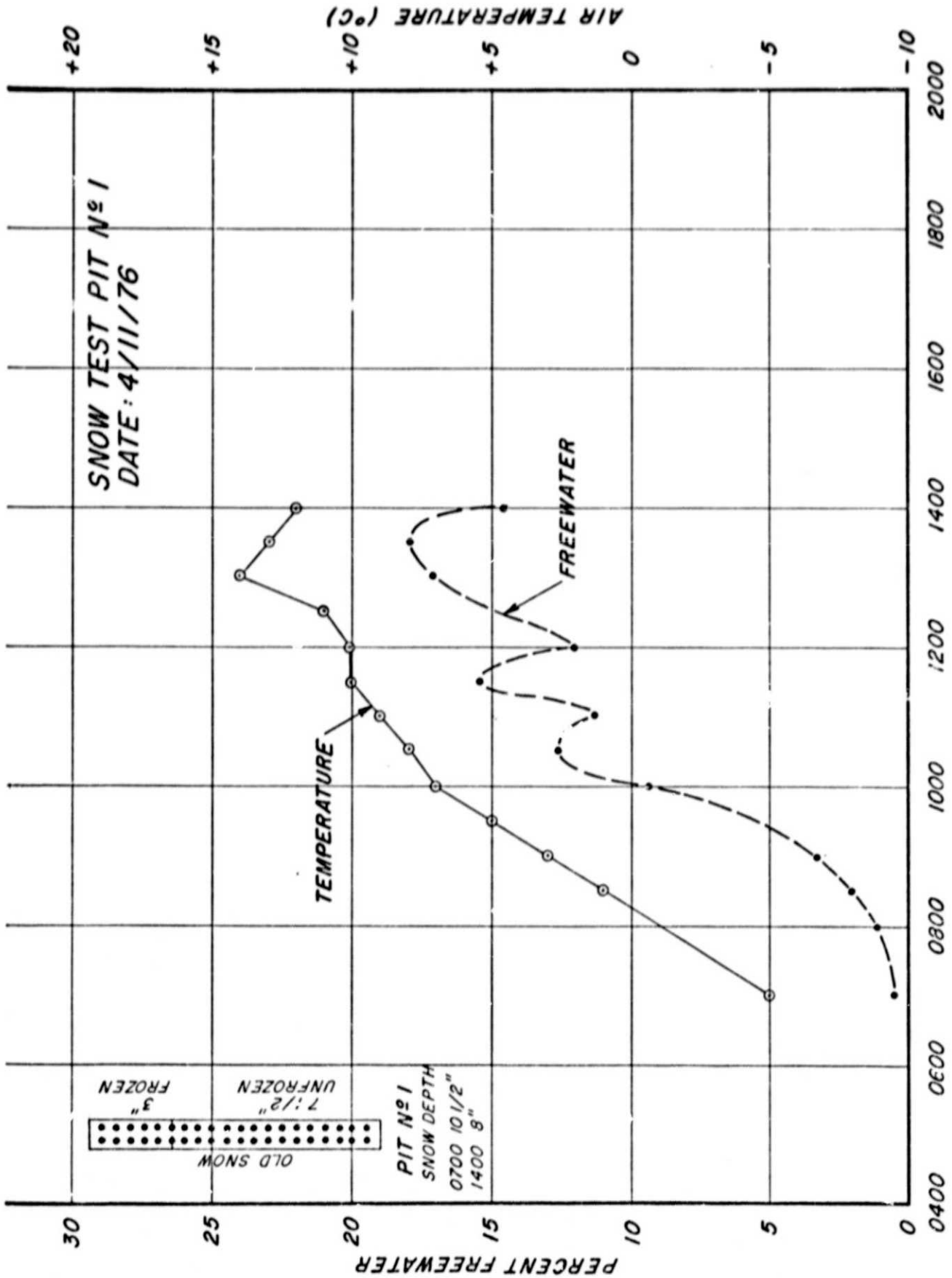

FIGURE 4.

Daily variation of free-water content in surface snow layer and air temperature, 4/9/76.



Daily variation of free-water content in surface snow layer and air temperatures, 4/11/76. FIGURE 5.

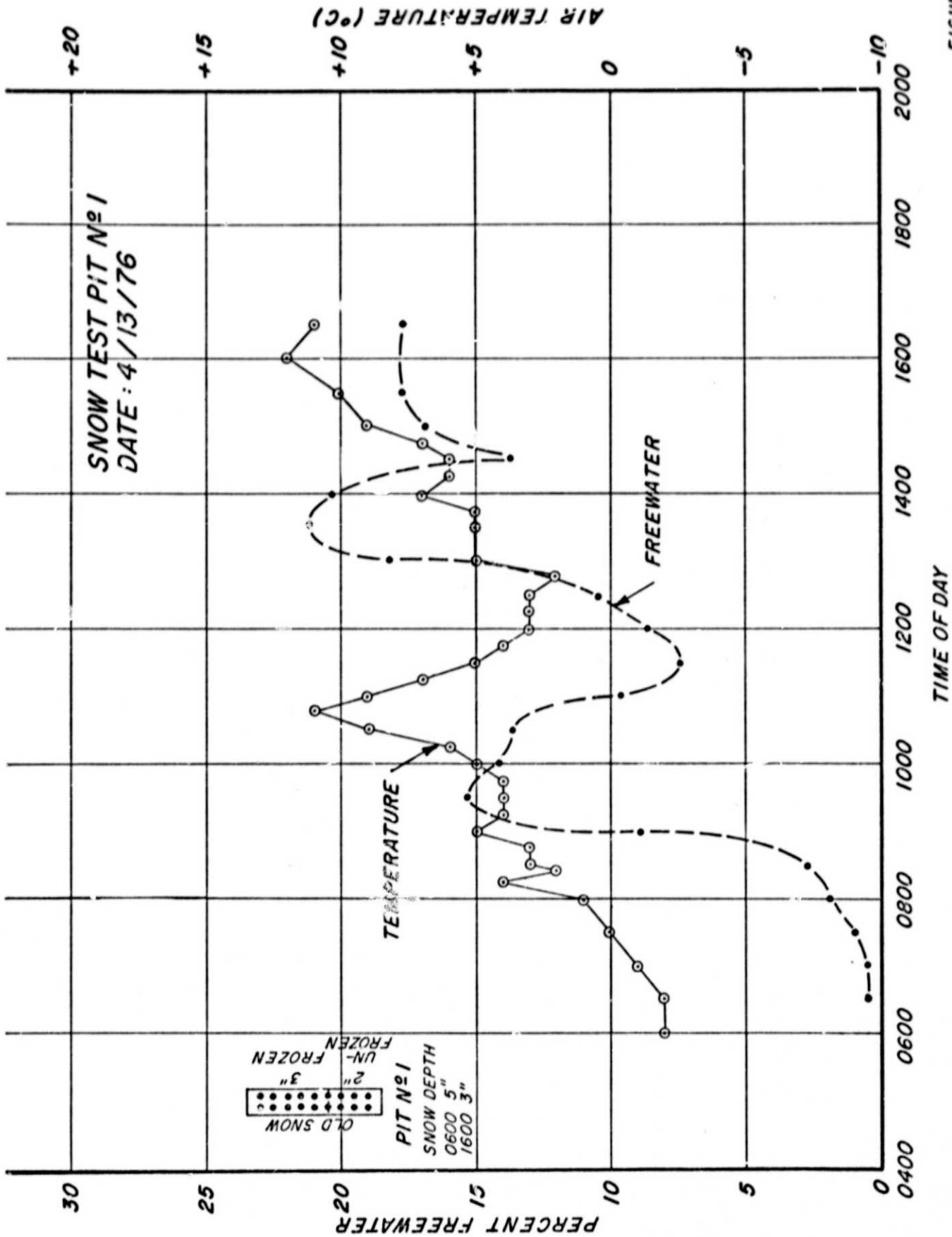

Figure 6. Daily variation of free-water content in surface snow layer and air temperatures, 4/13/76.

REFERENCES

- Leaf, Charles F., 1966, Free Water Content of Snowpack in Subalpine Areas, Proceedings--34th Western Snow Conference (April 19-21, 1966, Seattle, Washington), pp. 17-24.
- Sommerfeld, R. A., 1969, Classification Outline for Snow on the Ground, USDA, Forest Service Research Paper RM-48, Rocky Mountain Forest and Range Experiment Station, USDA, Fort Collins, Colorado, 24 pp.