

Volume I

Final
Report

June 1976

Summary Report

A Titan Exploration Study - Science, Technology, and Mission Planning Options

(NASA-CR-137846) A TITAN EXPLORATION STUDY:
 SCIENCE, TECHNOLOGY AND MISSION PLANNING
 OPTIONS, VOLUME 1 Final Report (Martin
 Marietta Corp.) 18 p HC \$4.00 CSCL 03B
 N76-29140
 Unclas 45901
 G1291

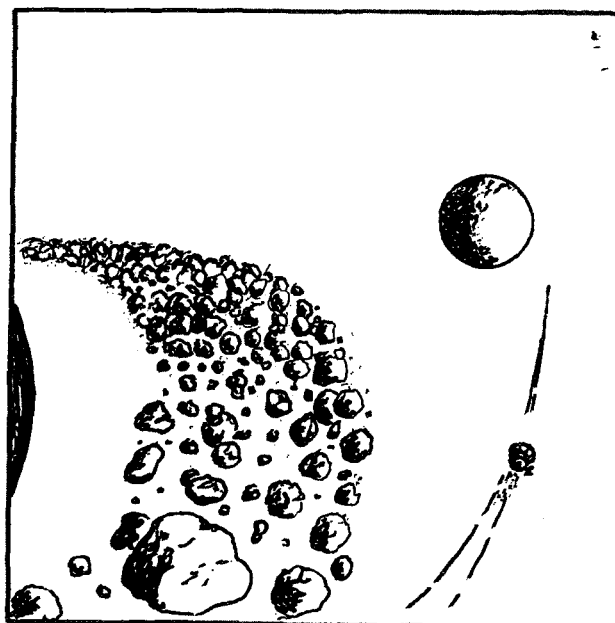

MARTIN MARIETTA

MCR-76-186

NASA CR 137846

VOLUME I
SUMMARY REPORT

A TITAN EXPLORATION STUDY - SCIENCE,
TECHNOLOGY AND MISSION PLANNING OPTIONS

MAY 1976

Distribution of this report is provided in the interest
of information exchange. Responsibility for the contents
resides in the organization that prepared it.

Prepared under Contract No. NAS2-8885 by

MARTIN MARIETTA CORPORATION
DENVER DIVISION
Denver, Colorado 80201

for

AMES RESEARCH CENTER
NATIONAL AERONAUTICS AND SPACE ADMINISTRATION

SUMMARY

This study effort has examined new mission concepts and technology advancements that can be used in the exploration of the Outer Planet satellites. Titan, the seventh satellite of Saturn was selected as the target of interest. Science objectives for Titan exploration were identified and recommended science payloads for four basic mission modes were developed (orbiter, atmospheric probe, surface penetrator and lander). Trial spacecraft and mission designs were produced for the various mission modes using existing technology. Using these trial designs as a base, technology excursions were then made to find solutions to the problems resulting from these conventional approaches and to uncover new science, technology and mission planning options. The measure of worth of these new options is their contribution to mission performance, reliability and science value. Several interesting mission modes were developed that take advantage of the unique conditions expected at Titan. They include a combined orbiter, atmosphere probe and lander vehicle, a combined probe and surface penetrator configuration, and concepts for advanced remote sensing orbiters.

ACKNOWLEDGEMENT

We acknowledge the following individuals for their contribution to this study:

E. L. Tindle, ARC
L. A. Manning, ARC
S. R. Sadin, NASA Hdq-OAST
L. E. Edsinger, ARC
P. R. Weissman, JPL
B. L. Swenson, ARC

STUDY TEAM

Program Manager	W. T. Scofield
Technical Directors	J. R. Mellin T. C. Hendricks
Technical Team	
Mission Analysis	A. L. Satin
Special Orbit Analyses	G. R. Hollenbeck
Technology Concepts	P. C. Carroll G. R. Hollenbeck W. H. Tobey
Science	B. C. Clark
Configuration	N. M. Phillips
Propulsion	R. Fearn
Thermal Control	T. Buna R. Giellis
Power	A. A. Sorensen
Guidance and Control	F. A. Vandenberg
Communications	R. E. Compton

CONTENTS

	<u>Page</u>
Summary	ii
Acknowledgement	iii
Contents	iv
List of Symbols	vi
I. INTRODUCTION	1
II. SCIENCE OBJECTIVES FOR TITAN EXPLORATION	5
III. MISSION AND SYSTEM APPROACH TO TITAN EXPLORATION	13
IV. APPLICATION OF NEW TECHNOLOGY TO TITAN EXPLORATION	20
V. STUDY CONCLUSIONS AND SUGGESTIONS FOR FUTURE WORK	29

Figures

1. Study Approach	3
2. Titan Exploration Mission Modes	4
3. Typical Titan Exploration Orbiter Mission	14
4. Typical Titan Atmospheric Probe Mission	15
5. Typical Titan Penetrator Mission	17
6. Typical Titan Soft Lander Mission	18
7. Titan Exploration Launch Vehicle Requirements Based on Conventional Spacecraft System	19
8. TOPL Configuration	21
9. Titan Orbiter/Probe/Lander Vehicle (TOPL) Mission Probes	22
10. Advanced Remote Sensing Titan Orbiter	24
11. Integrated Probe & Penetrator Configuration	25
12. Typical Advanced Technology Concepts	27
13. Typical Advanced Technology Concepts	28

Tables

1. Best Current Description of Titan	6
2. Candidate Science Payload-Orbiter	8

CONTENTS (Cont'd)

<u>Table</u> (Cont'd)	<u>Page</u>
3. Candidate Science Payload - Probe	9
4. Candidate Science Payload - Penetrator	10
5. Candidate Science Payload - Lander	11

LIST OF SYMBOLS

γ_E	Entry flight path angle
AMU	Atomic mass unit
ARSO	Advanced remote sensing orbiter
GCMS	Gas chromatograph mass spectrometer
GEX	Gas exchange (ala Viking GEX Life Detection)
h	Altitude
P_A	Atmospheric pressure
R_S	Saturn radius
R_P	Periapsis radius
S/C	Spacecraft
t	Time
T_A	Atmospheric temperature
TOPL	Titan Orbiter/probe/lander
V_E	Entry velocity
V_{HP}	Hyperbolic excess velocity

I. INTRODUCTION

New planetary exploration missions are very often made possible by the advancement of technology. Scientifically exciting programs will be put off or given up if they are too costly, pose unsolvable environmental problems, or demand excessive performance levels or accuracies. By removing these program planning road blocks through an early commitment to technology studies and research, the NASA Office of Aeronautics and Space Technology makes an important contribution to this nation's technological progress.

The work reported here is an example of the OAST policy of facilitating planetary exploration planning through technology advancement. It focuses on a mission that has recently vaulted into the planetary science limelite but which poses a number of difficult technical challenges, the exploration of Saturn's seventh satellite, Titan.

Thirty-two years ago Gerard Kuiper detected methane in the spectrum of Titan. Titan, larger than the planet Mercury, thus became the first and only satellite in the solar system known to have a significant atmosphere. Much later, in 1972, Laurence Trafton observed hydrogen in the Titan atmosphere and predicted that the surface pressure on the satellite was 200 millibars or more -- much higher than had been previously assumed. At about the same time infrared spectroscopy began to suggest atmosphere temperatures, increasing with depth, that could be as high as 200°K at the surface. Such surface temperatures could only be explained by a solar energy-trapping greenhouse effect.

The upshot of these accumulated findings about Titan has been a wave of intense interest and support from the planetary science community for exploration missions to the satellite. Here is a body with a warm, thick atmosphere exhibiting the highest ratio of methane to hydrogen of any known reducing atmosphere. As such it represents an environment that is in many respects like that of the primitive Earth at the time of the origin of life. Obviously then, Titan ranks with Mars as one of

the most likely places to search for extraterrestrial life or precursors to life, in the entire solar system.

Mounting a mission or series of missions to Titan, however, entails considerable difficulties. To launch payloads to Saturn orbit that would support conventional lander systems, would severely tax even the Shuttle-Tug capabilities. The ephemeris uncertainties of Titan limit the precision to which approach and encounter trajectories can be calculated. The uncertainties in the current knowledge of the Titan atmosphere and surface complicate the design of probes, landers or surface penetrators. The long transmission distances from Saturn to Earth and the sometimes limited communications windows make it difficult to return science data at sufficiently high bit rates. These and many other constraints on Titan or other outer planet satellite missions underline the need for technology advancement in many areas to make the exploration of these bodies a cost-effective undertaking.

The objective of this study was to identify and evaluate those technology excursions from the current state of the art that will benefit Titan exploration missions. The study approach followed the steps shown in Figure 1. Figure 2 depicts the generalized mission concepts that formed the starting points for technology advancements.

In the course of this study, a great deal has been learned about the technical challenges of exploring Titan that has not been examined before. This has stimulated the discovery of a number of technology improvements and exploration techniques that will not only make the exploration of Titan more practicable but will have possible application to missions to other outer planet satellites as well.

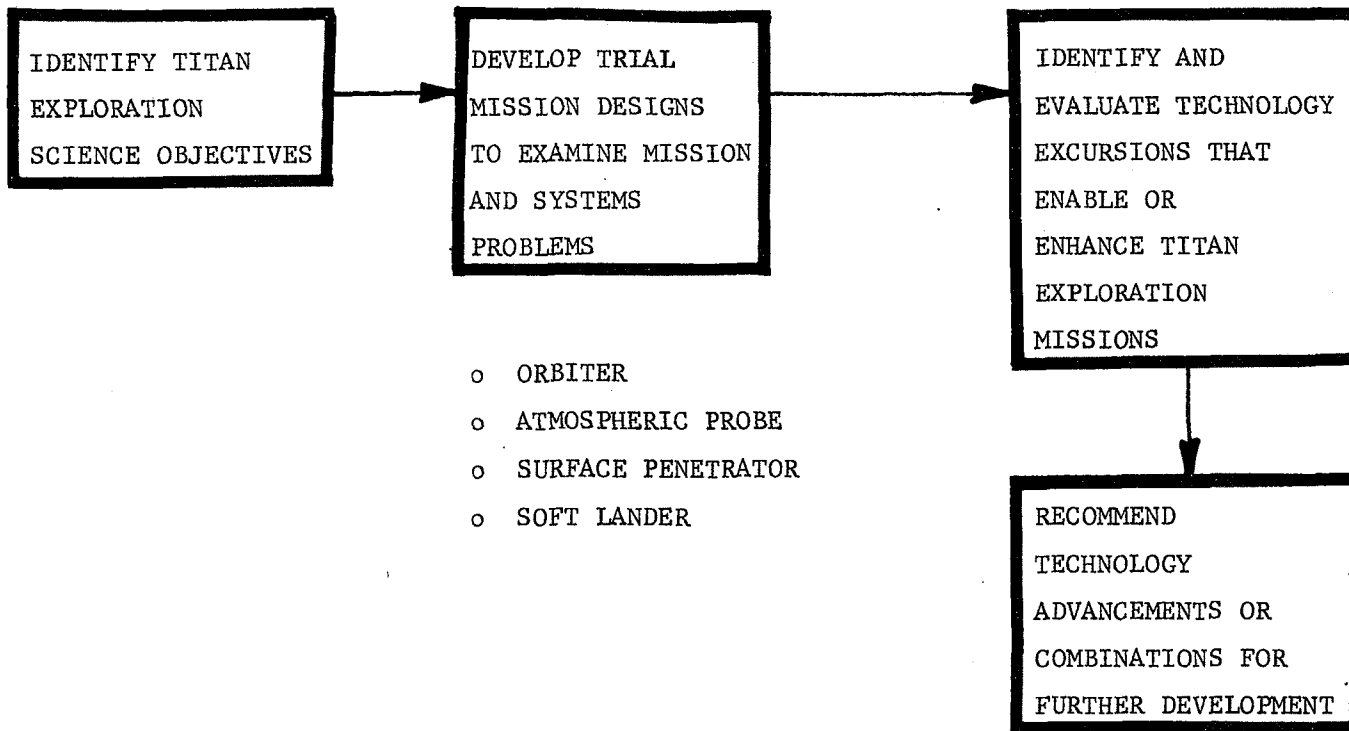

Fig. 1 Study Approach

4

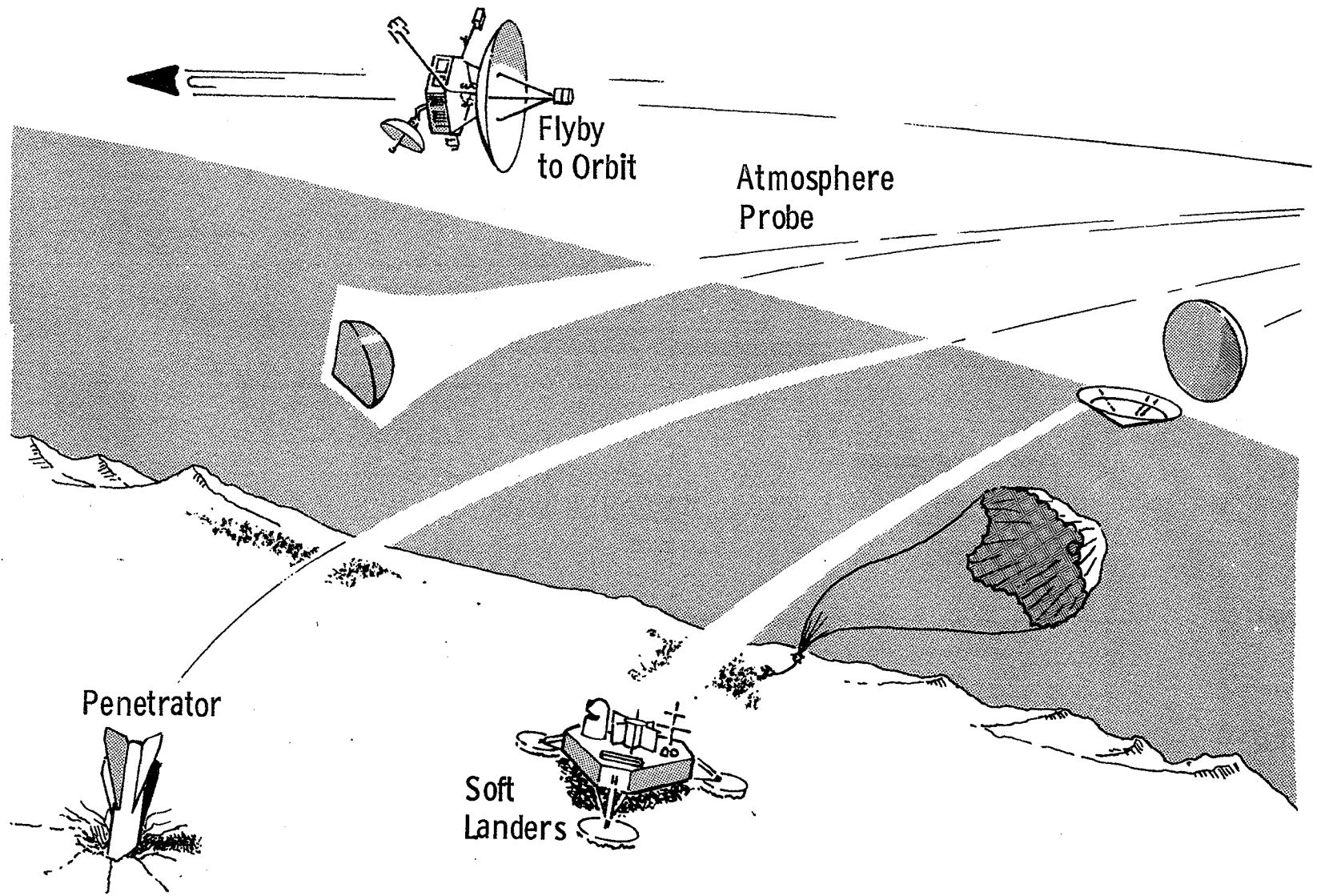

Fig. 2 Titan Exploration Mission Modes

II. SCIENCE OBJECTIVES FOR TITAN EXPLORATION

Titan, as a special example of an outer planet satellite, has become a high priority goal for exploration. Over the past thirty-two years an ever more fascinating list of characteristics has evolved from observations of this planet-sized moon of Saturn. Table 1 lists a current consensus of Titan features and properties. Even these characteristics are subject to almost daily revision as new data and new hypotheses are generated by an intensely interested science community.

The highest priority science question stimulated by our current knowledge of Titan is: what is the nature of the organic chemistry in the atmosphere and on the surface? The relatively warm, thick atmosphere and the presence of methane and hydrogen suggest an organic "soup" in which molecules may have synthesized into prebiotic or even living forms. Information on these processes could have a profound impact on our knowledge of how life formed and evolved on Earth.

In addition to the pressing issue of organics on Titan, other questions on the formation and evolution of the satellite are important. For example: when, how and of what was Titan formed? And: what processes are or have been at work there since its formation?

During the course of this study, Martin Marietta contacted a number of leading planetary scientists for their views on science strategies for Titan exploration. The highlight of these efforts was the science consultant meeting held in Denver on November 2, 1975 involving the following scientists:

Dr. Michael B. McElroy - Harvard University
Dr. Thomas Donahue - University of Michigan
Dr. Gordon H. Pettengill - MIT
Dr. Donald M. Hunten - Kitt Peak National Observatory
Dr. John S. Lewis - MIT
Dr. Alexander J. Dessler - Rice University
Mr. H. Julian Allen - Palo Alto, California
Mr. Harold Masursky - USGS/Flagstaff, Arizona

Table 1 Best Current Description of Titan

Radius	2700 \pm 200 km
Bulk Density	1.7 \pm 0.4 g/cm ³
Surface Acceleration	1.3 \pm 0.2 m/sec ²
Effective Temperature	85 \pm 2 ⁰ K
Rotational Period	15.9 Days
Surface Temperature	78 to 125 ⁰ K Negligible diurnal variation
Pressure at Surface	17 to 1,000 mbar (most probable = 400 mbar)
Surface Composition	Ices likely (methane and water ice, ammonium and methane clathrate hydrates). Hydrocarbon dusts (smog fallout), liquids, ices. Liquid methane possible, but improbable. Minor meteorite dust.
Atmospheric Composition	Methane, C-2 gases, (Hydrogen?). Nitrogen and/or neon.

9

Some of the ideas and recommendations that emerged in these discussions were:

- 1) Predictions on Titan surface conditions vary widely. Some, (e.g. Lewis and Hunten) favor a liquid methane model while others think a glassy asphalt surface fits the observations better.
- 2) Lewis predicts that if there is a crust, it is a thin one, <25 KM thick, which should be smooth except for the possible bulging effect of convection cells in the liquid just below it.
- 3) Heat flow should be relatively large - only a few times less than the Earth. Thus heat flow measurements should have high priority.
- 4) Some feel organic molecule synthesis cannot proceed beyond propane (C_3H_8) or possibly hexane (C_6H_{14}) in the atmosphere. Warm volcanic pools on the surface could support the growth to heavier organics. Hunten predicts that a layer of organic photolysis products could exist on the surface that is on the order of 1 km thick.
- 5) Passive microwave radiometry from orbit was suggested by Pettengill as a good experiment for detecting the temperature signatures of the surface and subsurface constituents.
- 6) Surface ices on Titan present challenges in how to determine their properties, constituents and ages. Lewis suggested low temperature X-ray diffraction, neutron diffraction and potassium argon dating (of salts in the ices) as possible experimental techniques.

As the result of these studies of the science rationale for Titan exploration, a number of recommended science payloads were defined as being appropriate for the four basic mission modes: orbiter, atmospheric probes, surface penetrators and landers. Table 2, 3, 4 and 5 identify these payloads.

Table 2 Candidate Science Payload-Orbiter

1. Imaging Science
2. Radio Science
3. Cosmic Ray
4. Planetary Radio Astronomy
5. Plasma Wave
6. Low Energy Charged Particles
7. Photopolarimeter
8. UV Spectrometer
9. Magnetometer
10. IR Interferometer Spectrometer

Table 3 Candidate Science Payload-Probe

1. Atmospheric Mass Spectrometer
(Light Gases, 1-50 AMU)
2. Organic Mass Spectrometer
(Complex Molecules, 50-250 AMU)
3. Gas Chromatograph
(Light Organics and Other Condensibles)
4. UV Multi-band Photometer
(Solar Pointing; Profiles Photochemical Constituents)
5. Accelerometer, Temperature, Pressure Transducers
(Atmospheric Physical State Profile)
6. Impact Transducer
(Surface Location and Gross Physical Properties)

Table 4 Candidate Science Payload-Penetrator

1. Mass Spectrometer with Heated Inlet
(10 to 300 AMU; Liquids, Ices, Organics)
2. Accelerometer
(Physical Properties of the Surface)
3. Temperature Array
(Subsurface Temperature; Thermal Properties)

Table 5 Candidate Science Payload - Lander

1. Combined GCMS*/Life Detection
(Organic Compounds - Smog; Metabolism via GEX*)

2. Atmospheric Sensor Array
(Temperature, Pressure)

3. Camera
(Image Terrain, Cloud Cover Dynamics)

4. Surface Sampler
(Sampling; Physical and Thermal Characteristics of Surface)

* GCMS = Gas Chromatograph + Mass Spectrometer

* GEX = Gas Exchange (ala Viking GEX Life Detection)

The science objectives for Titan exploration impose a number of mission and systems design challenges, many of which will best be met through new concepts and advanced technology. These challenges include:

- 1) Telecommunications links to support high resolution imagery and long duration organics and life detection experiments. This implies high data rates and maintenance of good link geometry for long periods;
- 2) Implementation of heat flow experiments in a surface of unknown composition and structure;
- 3) Sampling surface material of unknown physical state;
- 4) Age dating techniques for icy materials;
- 5) Gathering synoptic or satellite - wide science data.

Probably the most challenging requirement of all is to answer the questions posed by the planetary science community within a reasonable time period. If a conservative approach were taken in which a series of Titan missions were flown with each waiting for the completion of the previous one before commencing the next logical step, the missions could only be done at ten-year intervals. This sort of timing could not support an active program of exploration or the continued interest of scientists. Therefore techniques for combining exploration objectives into mission modes and systems concepts that can tolerate uncertain and unknown conditions were given high priority in this study.

III. MISSION AND SYSTEMS APPROACH TO TITAN EXPLORATION

Three major factors complicate the design of missions and systems for Titan exploration:

- 1) The long cruise times to Saturn (typically 4 to 7 years) make it impractical to plan conservative, step-wise missions in which the results of one flight can be used to plan a subsequent, more ambitious one;
- 2) The uncertainties in Titan's ephemeris, atmosphere and surface make it difficult to design systems that will function over the range of conditions that could conceivably be encountered;
- 3) Launch vehicle performance requirements for missions to Saturn are high enough that usable payloads for orbiter, atmospheric probe, surface penetrator and lander missions are seriously constrained by the projected Shuttle-IUS and Shuttle-Tug capabilities.

The first step in this study was to examine these factors and to determine whether current technology or spacecraft concepts can be used to meet Titan exploration science objectives in a cost effective way or whether advanced technology is indicated. Four trial mission/system designs were developed to assess the applicability of current technology to these objectives.

Figure 3 depicts the characteristics of a typical orbiter mission in which a Saturn orbit is achieved that provides a close encounter with Titan every 32 days. The vehicle weights shown represent application of Pioneer (spin-stabilized) and Mariner (3-axis stabilized) technology.

Figure 4 summarizes a Titan atmospheric probe mission. The probe technology used has been drawn from the Ames Research Center's outer planet probe program. The entry conditions are much less severe for this probe than for the Jupiter probe, primarily due to the reduced entry velocity (5.84 km/s vs 50 km/s). This means the probe can be smaller than the Jupiter version (100 kg vs 150 kg) and still carry a full complement of science instruments.

14

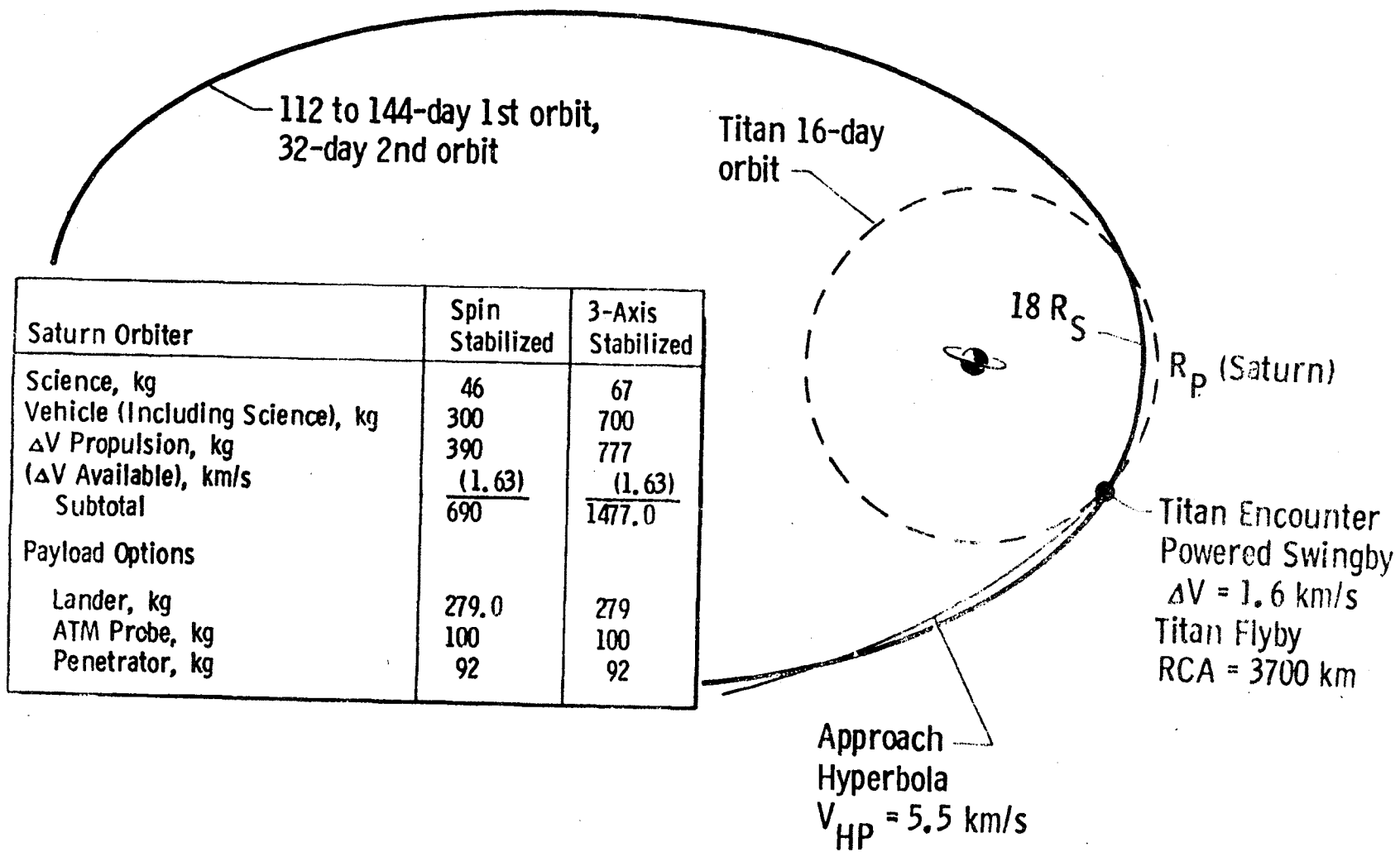

Fig. 3 Typical Titan Exploration Orbiter Mission

15

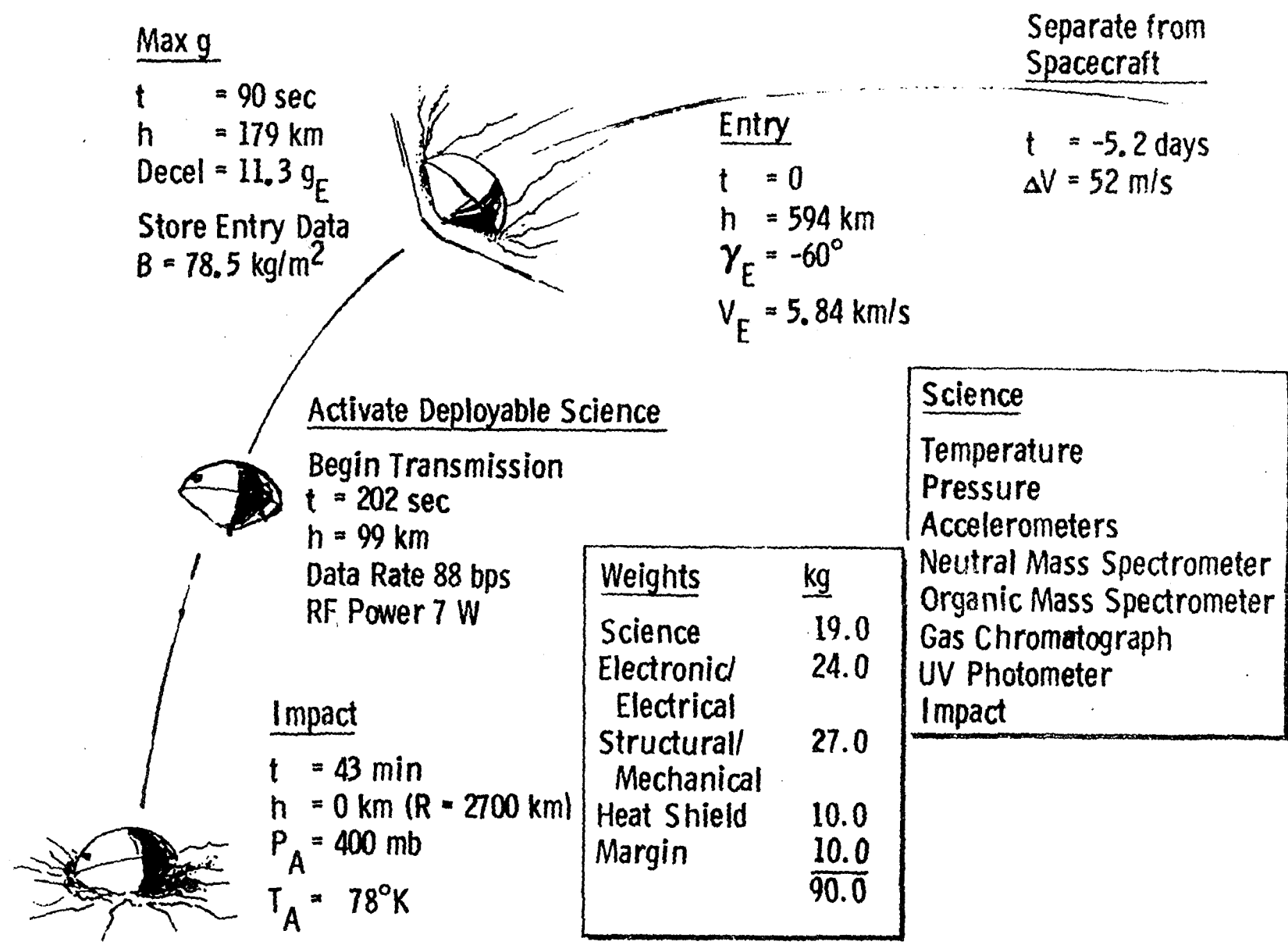

Fig. 4 Typical Titan Atmosphere Probe Mission

A typical Titan surface penetrator mission is shown in Figure 5. This is a direct application of the technology developed by Sandia Corporation for Earth penetrators and later studied for application at Mars. The penetrator can tolerate some degree of uncertainty in the atmosphere which would make the impact velocity vary. It also offers the advantage of providing access to subsurface regimes for certain science instruments.

Figure 6 describes a Titan soft lander mission based on Viking technology. The lander however is smaller than Viking (279 kg vs 597 kg) to provide a closer match to the projected launch vehicle performance capabilities for Saturn missions.

All four of these trial mission designs do appear to be feasible techniques for Titan exploration. However, none of them satisfies all of the three conditions of: 1) meeting the first priority science requirements; 2) tolerating the potential uncertainties at Titan; and, 3) remaining within the launch system performance capabilities.

Figure 7 illustrates the third point, showing the projected performance to Saturn for the Shuttle-IUS and Shuttle-Tug over the time period thru the 1990's. The only opportunities in which the probe, penetrator or lander missions can be flown with a three-axis bus are 1985 and possibly 1998. These ballistic trajectory mode performance limits can be improved upon in the 1990's when planetary alignments permit Jupiter swingby missions to be flown.

It is clear that mission and spacecraft design approaches that require less throw-weight, can perform the high priority atmosphere and surface science investigations, and can adapt to uncertainties in the Titan ephemeris, atmosphere and surface characteristics, will require more than conventional technology.

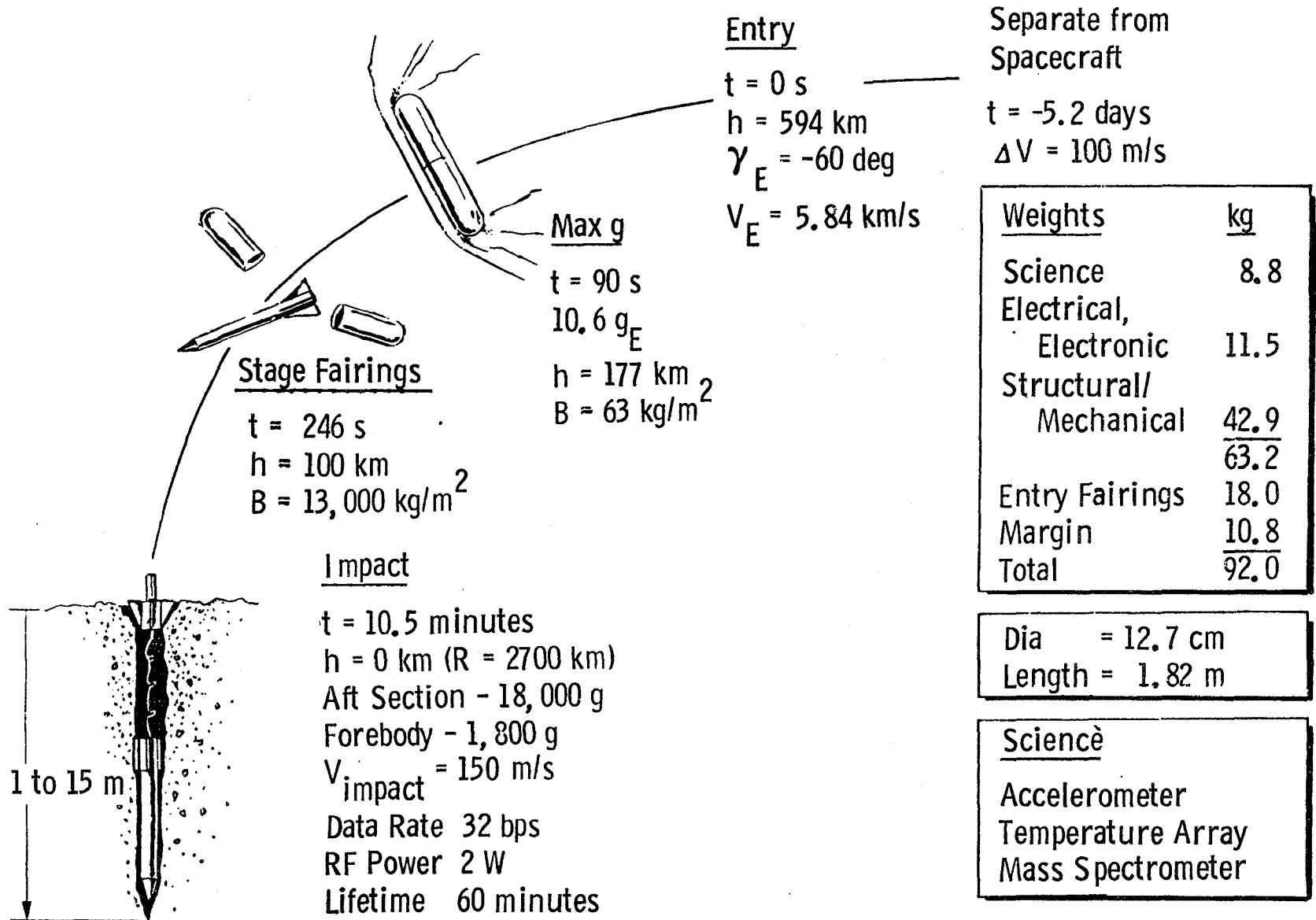

Fig. 5 Typical Titan Penetrator Mission

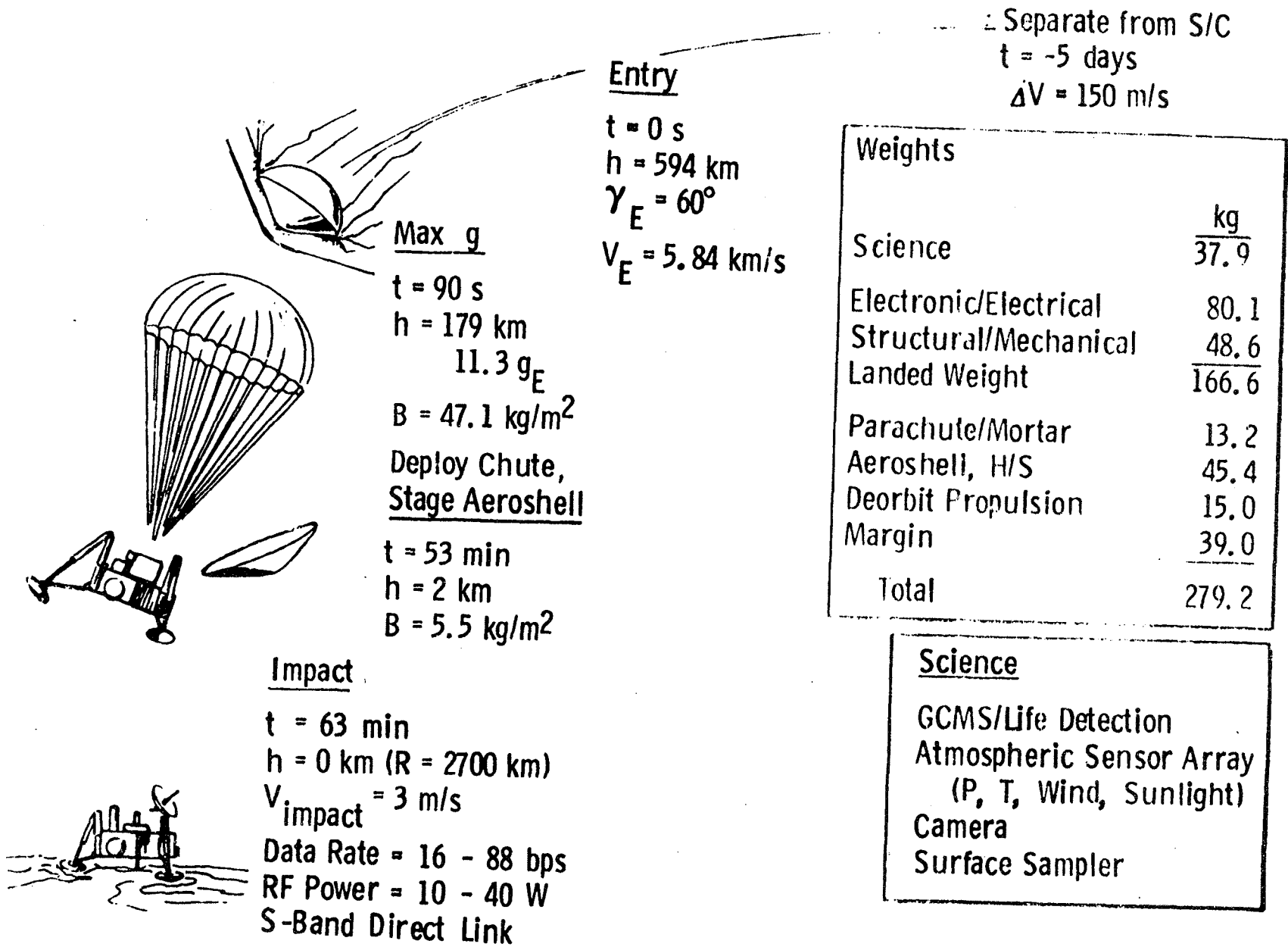

Fig. 6 Typical Titan Soft Lander Mission

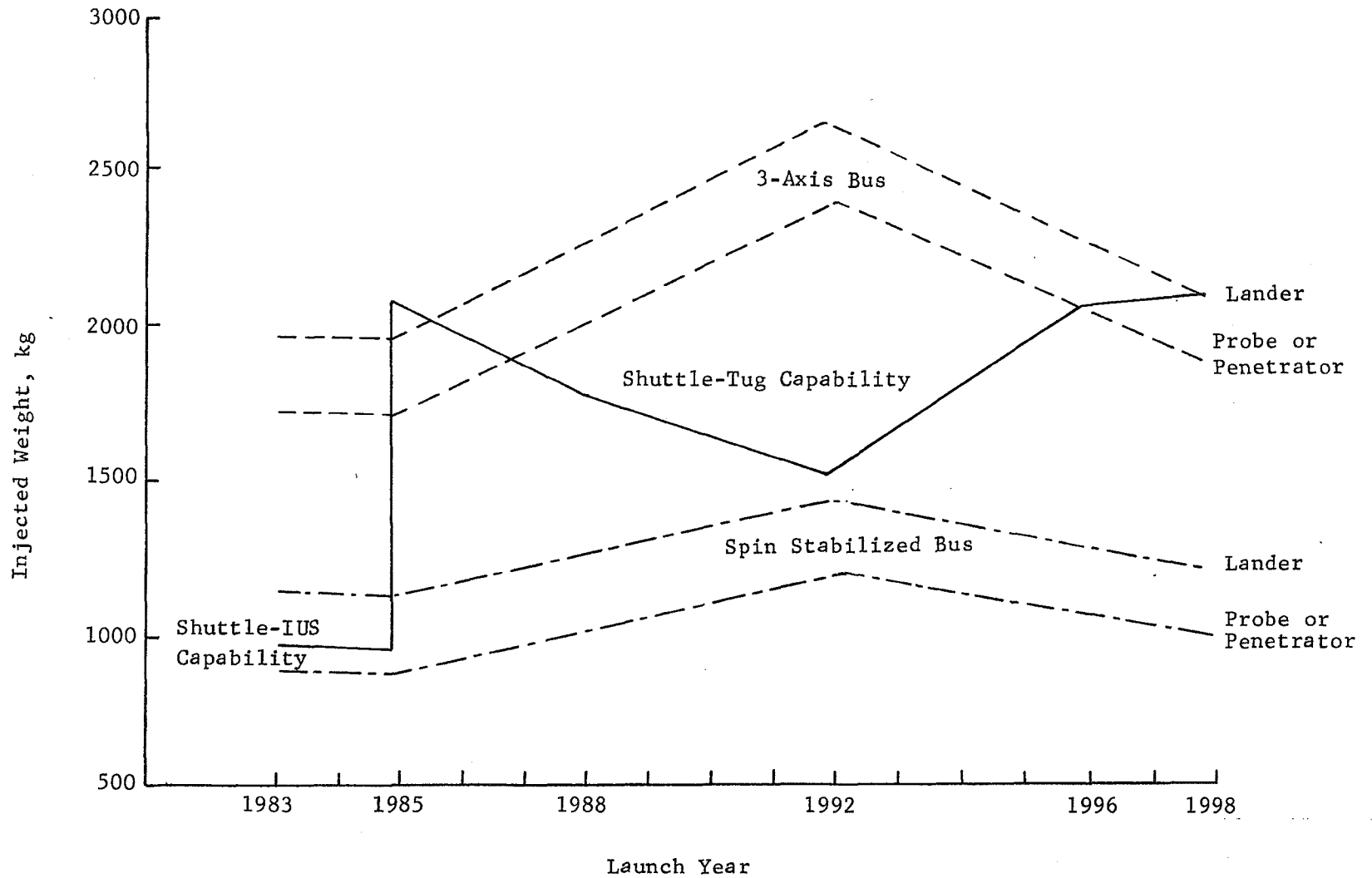

Fig. 7 Titan Exploration Launch Vehicle Requirements based on Conventional Spacecraft System

IV. APPLICATION OF NEW TECHNOLOGY TO TITAN EXPLORATION

Several new mission and spacecraft concepts were developed in this study that offer attractive advantages for Titan exploration. They will deliver answers to the high priority science questions without the need for precursor missions and without being vulnerable to the uncertainties in the Titan environment.

A large number of specialized technology advancements was also identified and examined in the study that can support either the new mission/spacecraft modes or more conventional Titan exploration missions.

A. TITAN ORBITER, PROBE AND LANDER (TOPL)

Because Titan has a relatively small gravitational acceleration (1.3 m/sec^2 vs 9.8 m/sec^2 at Earth) its atmosphere is not concentrated at the surface but extends to high altitudes with significant density. This large atmosphere scale height, coupled with the low orbital velocities that can be achieved at Titan, provide some special conditions that can be exploited with ingenious spacecraft design.

A vehicle in orbit at Titan can be deorbited or deflected into the atmosphere where it will begin to slow down at high altitudes. As it slows it will penetrate further until ultimately it will decelerate to a safe landing velocity. Because the entry heating is thus spread over a long time period and because the entry velocity to begin with was not high, the absorbed heating can be reradiated back to space during the descent without excessive elevation of the spacecraft surface temperature. Thus a single vehicle can function as a Titan orbiter, atmospheric probe and lander. Such a vehicle, designated TOPL, for Titan Orbiter, Probe and Lander, is shown in Figure 8. The TOPL operational sequence is shown in Figure 9.

B. ADVANCED REMOTE SENSING ORBITER (ARSO)

There is a very active school of thought in planetary exploration that holds that many if not most of the primary science questions at a planetary body can be answered with a well equipped orbiter. To examine

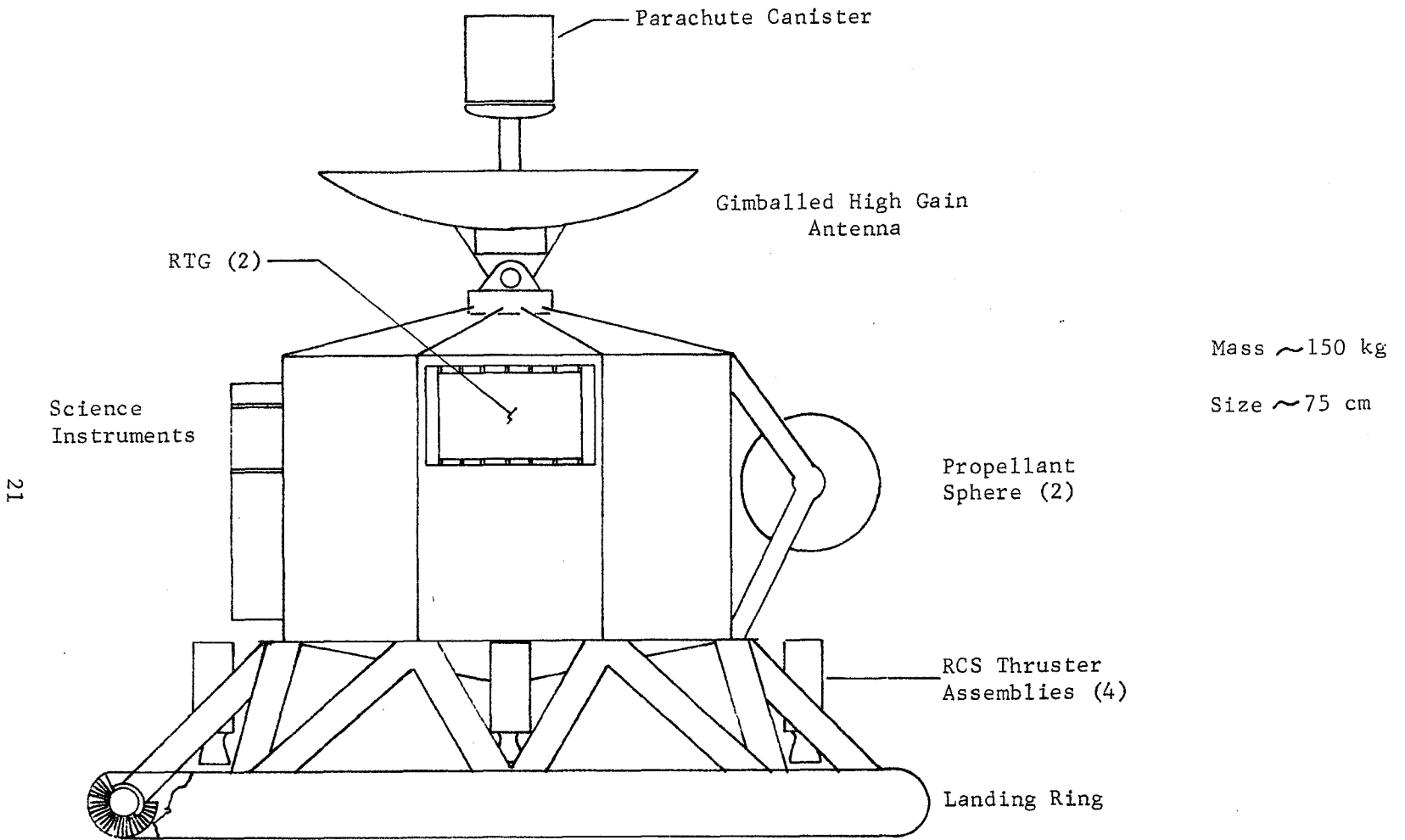
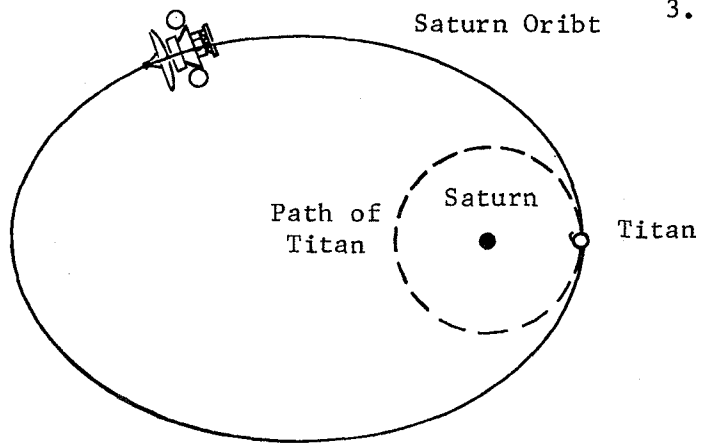
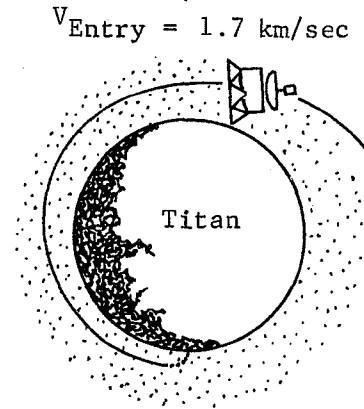

Fig. 8 TOPL Configuration

1. Total System Inserted into Saturn Orbit



3. Upper Atmosphere Measurements and Entry Data Obtained



4. Lower Atmosphere Measurements Taken (Probe Type Data)

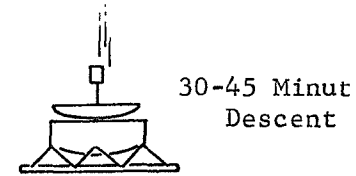

2. TOPL Performs Orbital Science in Titan Orbit

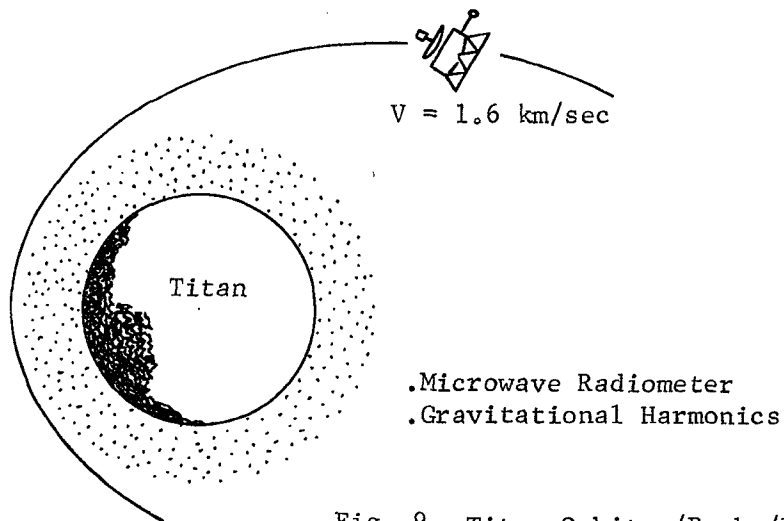

5. Landed Science Experiments

$V_{\text{Impact}} = 11 \text{ m/s}$

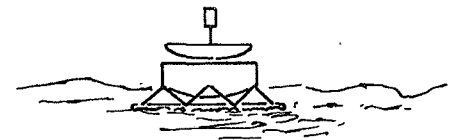

22

Fig. 9 Titan Orbiter/Probe/Lander Vehicle (TOPL) Mission Phases

this approach for Titan exploration, we developed the orbital maneuver strategies and configured an orbiting vehicle that can produce high quality remotely sensed scientific data.

Careful use of Titan gravitational effects can save some 1 km/sec of velocity in achieving an orbit about Titan. The Titan orbiter can then observe the satellite with advanced visual, radar, IR and UV sensors to study topography, surface composition, aeronomy and surface/atmospheric interactions. Figure 10 shows a configuration for an advanced remote sensing orbiter for Titan.

C. PENETRATOR AND ATMOSPHERIC PROBE FOR TITAN (PENETROBE)

The Penetrobe configuration combines the features of an atmosphere sensing entry probe and a surface penetrator and can adapt to the wide range of densities represented by the thick, nominal and thin atmosphere models. Figure 11 shows the configuration and indicates how the surface penetrator is integrated into the probe body and separated during the descent at a time determined by the atmospheric density actually encountered.

If the Penetrobe senses the thin Titan atmosphere it will separate the penetrator high in the descent path thereby reducing the ballistic coefficient of the probe and slowing its descent. If the thick atmosphere is encountered the penetrator will remain with the probe to quicken its descent and will be fired into the surface with solid propulsion motors to achieve adequate penetration depth. Such an adaptive device as this could be flown in an early mission to Titan to return high priority atmosphere and surface science data before the uncertainties in the Titan environment are resolved.

D. TECHNOLOGY ADVANCEMENTS FOR TITAN EXPLORATION

The examination of the trial mission designs for Titan exploration that were developed early in this study revealed many areas where new technology could either enable a problem to be solved or could enhance the performance of the mission. As the result of these examinations,

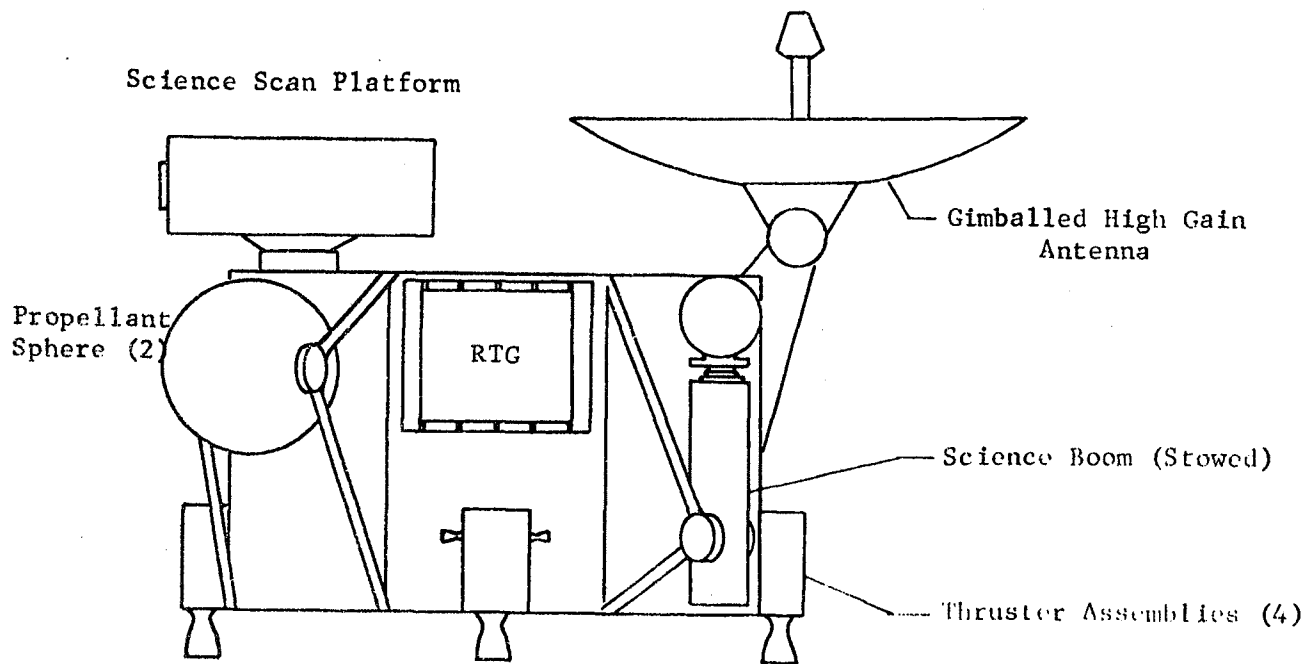

24

Fig. 10 Advanced Remote Sensing Orbiter (ARSO)

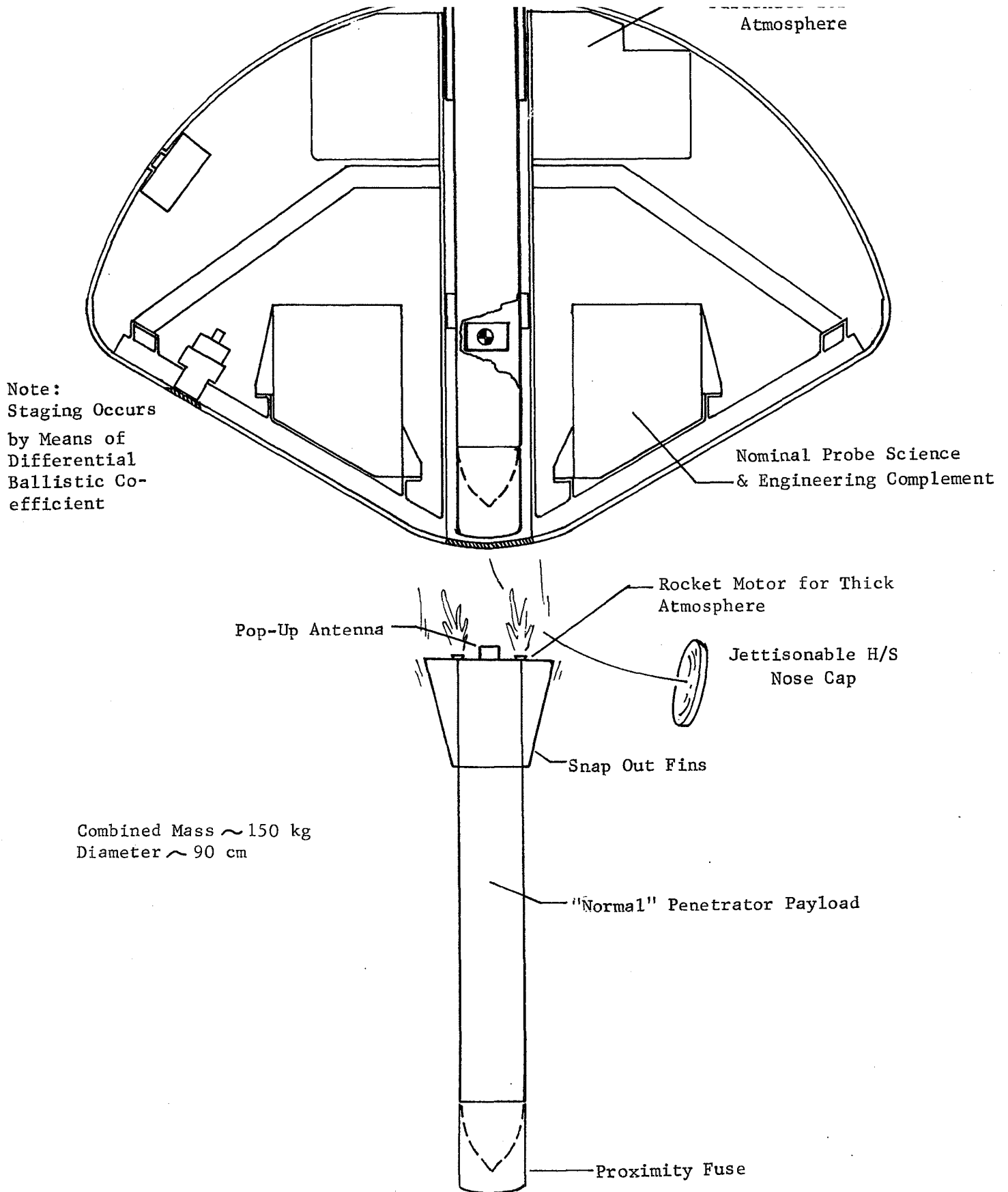
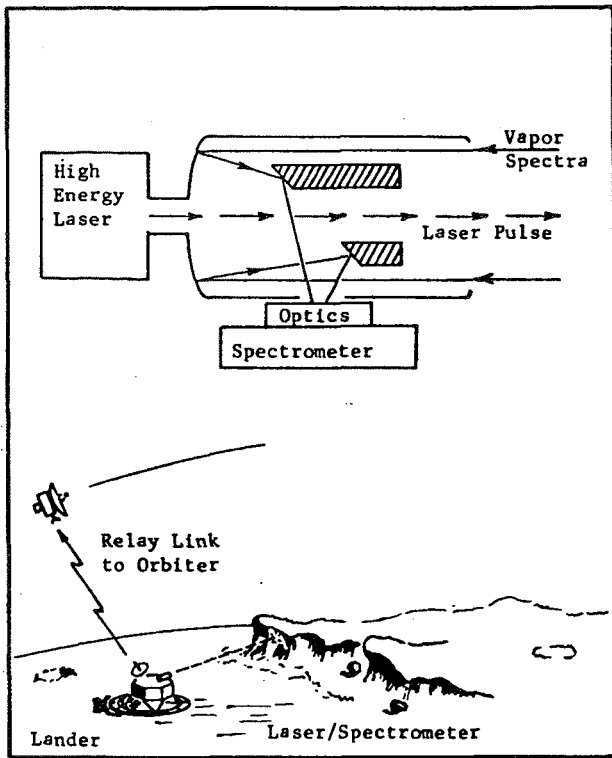
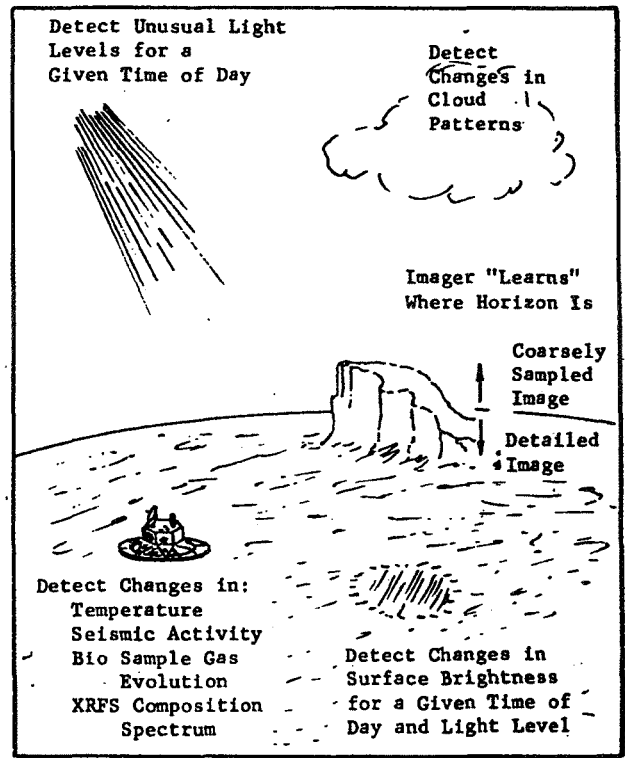

Fig. 11 Integrated Probe & Penetrator Configuration (Penetrobe)

approximately twenty new technology applications were developed. Some can be applied to the TOPL, ARSO or Penetrobe concepts, some have more universal application to a wide range of advanced spacecraft missions. Figure 12 and 13 show a sample of the new technology ideas produced in the study that are described in the second volume of this report.



Laser/Spectrometer Analyzer



Typical Adaptive Science Decisions

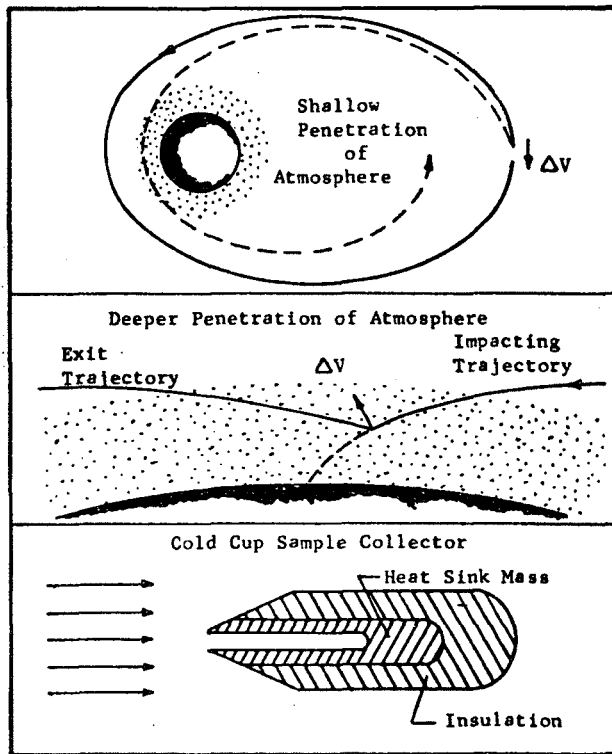

Atmosphere Sampling From Orbit

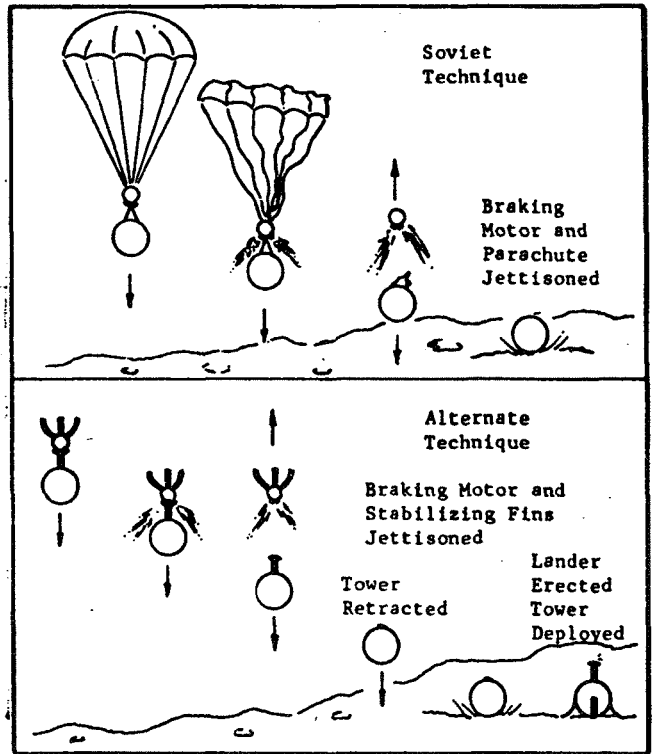

Tractor Braking for Surface Landers

Fig. 12 Typical Advanced Technology Concepts

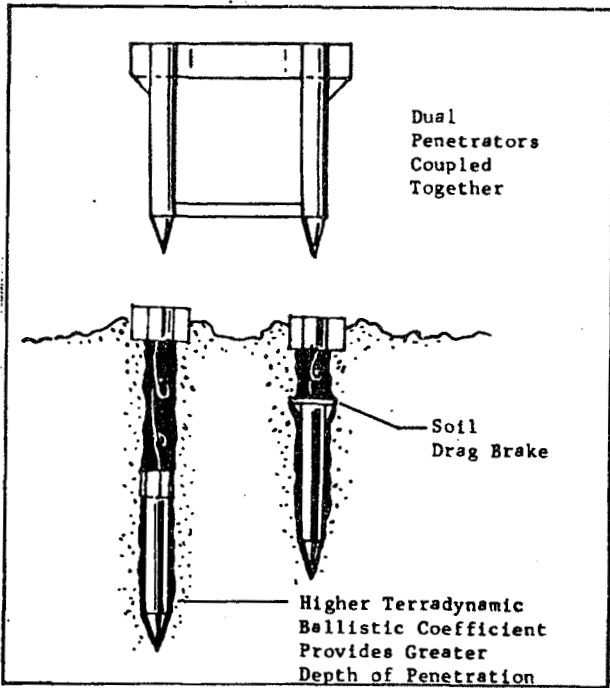

Dual Penetrator Configuration

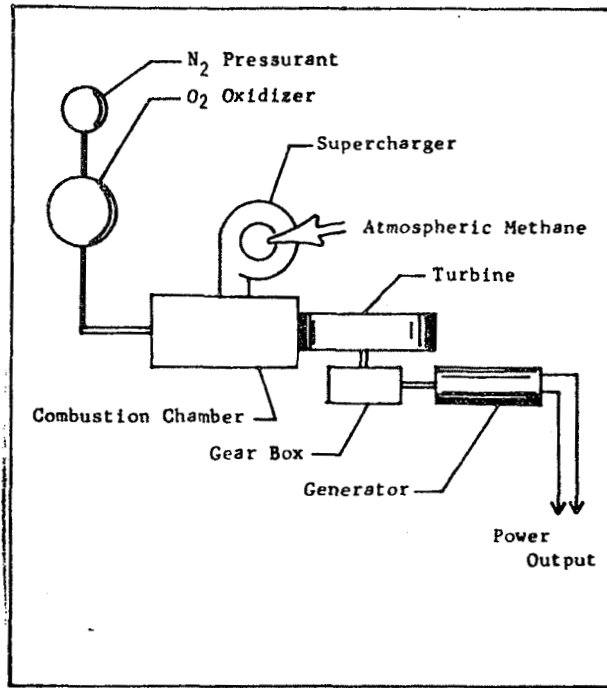

Methane Powered Turbine for High Peak Power

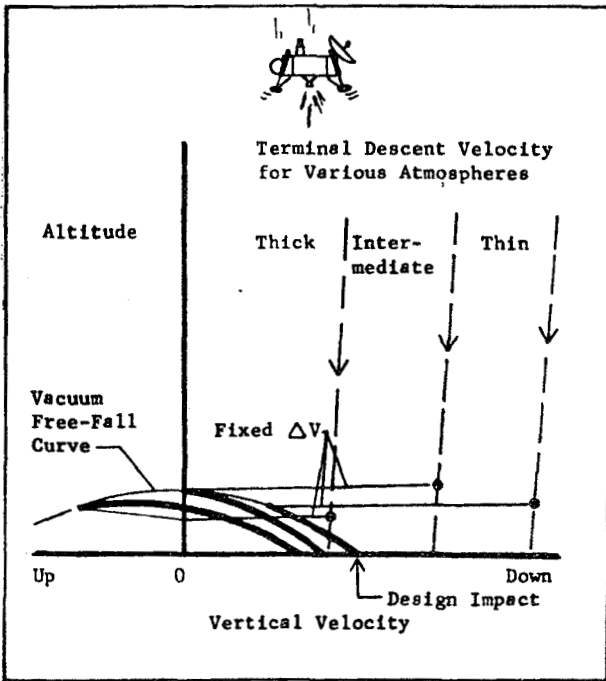

Fixed ΔV Landing System Concept

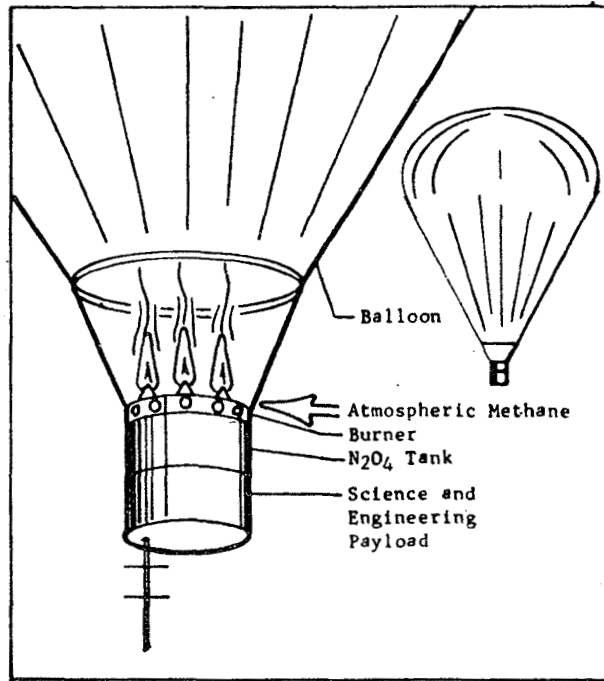

"Hot Atmosphere" Balloon Concept

Fig. 13 Typical Advanced Technology Concepts

V. STUDY CONCLUSIONS AND SUGGESTIONS FOR FUTURE WORK

The results of this study point up clearly the problems we will face if we attempt to approach the exploration of Titan in the same manner that we have undertaken the examination of the moon or Mars. For example, the four missions to Mars (Mariner 64, 69, 71 and Viking '75) that were required before we could investigate the organic chemistry and biology on the surface of the planet, took approximately 12 years to perform. To follow the same mission evolution at Titan would take at least 30 years. Furthermore, the uncertainties about the atmosphere and surface of Titan are greater now than were our unknowns about Mars in 1964. Therefore, if we are to proceed with the exploration of Titan in this generation, new strategies and new technological approaches will be required.

Three mission modes for Titan exploration were identified during the study any of which could be employed in a first mission. If the enthusiasm among planetary scientists for investigating the organic chemistry at Titan is sustained or increases, then the TOPL mission mode should be given high priority for an early flight. TOPL allows the widest range of science experiments to be carried out from orbit, in the atmosphere and on the surface with only a modest commitment in terms of spacecraft cost and complexity.

If planetary scientists are willing to delay the performance of the more sophisticated surface science experiments, then the Penetrobe concept may be the preferred choice for the first mission. The Penetrobe can adapt to a wide spread in atmospheric density while conducting atmospheric and rudimentary surface science.

An advanced remote sensing orbiter would be the most conservative first mission to Titan but depending on the sophistication of the sensor system, could meet many of the high priority science objectives.

It is recommended that all three mission modes be studied in more detail. The TOPL deserves additional examination because it offers some very attractive advantages under the unique conditions at Titan.

The Penetrobe can be derived from the outer planets probe and the Mars penetrator technology bases but the special adaptive features that allow it to handle the Titan uncertainties need further study.

Of the specialized technology advancements identified in the study as potentially valuable for Titan exploration, several warrant particular attention. The several concepts for balloon deployment from descending or landed vehicles to extend the science data gathering capabilities have application in outer planet and Venus missions as well as in Titan exploration. The tractor braking and preprogrammed ΔV braking ideas for small, low-cost landings on solid bodies also offer potential applications to other missions such as those to Mercury, the moon, Mars, Phobos, Deimos and the outer planet satellites.

The whole field of adaptive controls and on-board decision-making holds great promise for future planetary exploration. The new technology ideas involving adaptive descent control for probes, penetrators and landers, on-board science decisions, and adaptive thermal control, developed in this study, are typical of this new wave of technology.

The exploration of the outer planet satellites, and in particular Titan, beckons as an exciting and mysterious frontier. Through the imaginative application of today's knowledge we can fashion the new tools and techniques that will allow us to explore that frontier.