

2453

NASA TECHNICAL NOTE



NASA TN D-8298

NASA TN D-8298

APOLLO EXPERIENCE REPORT -  
LUNAR-SAMPLE PROCESSING IN  
THE LUNAR RECEIVING LABORATORY  
HIGH-VACUUM COMPLEX

*David R. White*

*Lyndon B. Johnson Space Center*

*Houston, Texas 77058*



## CONTENTS

Section	Page
SUMMARY . . . . .	1
INTRODUCTION . . . . .	1
Design Requirements . . . . .	2
Quarantine Requirements . . . . .	2
Scientific Requirements . . . . .	3
Engineering Requirements . . . . .	4
VACUUM SAMPLE-PROCESSING COMPLEX DESCRIPTION . . . . .	5
F-201 Vacuum Glove Chamber . . . . .	5
Vacuum Transfer Chambers . . . . .	10
Vacuum Storage Chambers . . . . .	12
Atmospheric Decontamination System . . . . .	13
F-601 Ultra-High-Vacuum Chamber . . . . .	14
Control Console . . . . .	15
DEVELOPMENT AND OPERATIONAL DIFFICULTIES . . . . .	15
Maintenance of the Vacuum Environment . . . . .	15
Arm and Glove Assembly . . . . .	19
Adaptability of Tools and Containers to Operator, Gloves, and Vacuum Environment . . . . .	23
Mechanisms of Transfer Between Associated Vacuum Chambers . . . . .	27
Sample Processing . . . . .	29
Development of an Effective Operational Team . . . . .	33
POSTMISSION PROCESSING . . . . .	35
CONCLUDING REMARKS . . . . .	36

## FIGURES

Figure		Page
1	The LRL high-vacuum complex . . . . .	3
2	A schematic diagram of the LRL high-vacuum complex . . . . .	6
3	High-vacuum-complex control console . . . . .	7
4	The F-201 vacuum glove chamber . . . . .	8
5	The glove operator area of chamber F-201 . . . . .	9
6	LRL 101.3-kN/m <sup>2</sup> (1 atmosphere) arm/glove system . . . . .	10
7	Apollo 11 lunar sample . . . . .	11
8	The F-207 sample carousel . . . . .	12
9	Bolt-top sample containers . . . . .	13
10	Single-action sample containers . . . . .	13
11	Dolly and basket . . . . .	14
12	Sample container dolly . . . . .	14
13	Shoulder, arm, and glove assembly . . . . .	19
14	Glove and wrist assembly . . . . .	20
15	Side view of glove and wrist assembly . . . . .	20
16	Overglove sleeve and glove assembly . . . . .	20
17	ALSRC jack F-201-139 . . . . .	24
18	ALSRC opening pliers (SEZ 36104697-301) . . . . .	24
19	Ratchet and 0.95-centimeter (0.375 inch) drive (SK 67606-110) . . . . .	25
20	Canholder assembly (SDZ 36106027-301) . . . . .	25
21	Five-centimeter (2 inch) scoop (SEZ 36104724-301) . . . . .	25
22	Hammer (SEZ 36104728-301) . . . . .	25
23	T-handle (SEZ 36106104-301) . . . . .	26

Figure		Page
24	Tweezers (SEZ 36104416-301) . . . . .	26
25	Floor brush (SEZ 36104408-302) . . . . .	27
26	Universal handle (SEZ 36104404-301) . . . . .	27
27	Radiation counting sample containers and tools . . . . .	28

APOLLO EXPERIENCE REPORT  
LUNAR-SAMPLE PROCESSING IN THE LUNAR RECEIVING  
LABORATORY HIGH-VACUUM COMPLEX

By David R. White  
Lyndon B. Johnson Space Center

SUMMARY

The high-vacuum complex was constructed specifically for the preliminary examination, in a vacuum environment, of lunar material returned by Apollo crewmembers. Quarantine status of the lunar material was to be maintained during the examination. The high-vacuum complex was used for Apollo 11 and 12 sample processing. Initial anomalies and constraints that resulted from receiving the lunar material, meeting the design-philosophy requirements for vacuum processing, and supporting the basic functions of the chamber team were identified and problems were solved. These anomalies and constraints included the maintenance of the vacuum environment, the constraints imposed by the arm and glove assembly on the operator and chamber tools, the adaptation of tools and containers to the vacuum environment, the mechanism of transfer between associated chambers, the procedures for sample processing, and the development of an effective operational chamber team. After these problems were solved, the vacuum complex began to reach its full potential during postmission processing. However, no samples were returned from the Apollo 13 mission and the scientific requirements for vacuum sample processing were deleted for the Apollo 14 and subsequent missions.

INTRODUCTION

In 1964, a special ad hoc committee of the National Academy of Sciences considered the implications of the Apollo flights to the Moon and the return to Earth of lunar samples for study by investigators throughout the world. A system was needed to process returned lunar samples in a controlled vacuum environment, to prevent terrestrial contamination of lunar-sample materials, and to prevent release of possible lunar organisms into the surrounding environment. For these purposes, the Lunar Receiving Laboratory (LRL) high-vacuum complex was built.

The high-vacuum sample-processing complex is composed of the atmospheric decontamination system, the transfer system, the sample-processing chambers (the F-201 vacuum glove chamber and the F-601 ultra-high-vacuum chamber), and the sample- and tool-storage chambers (carousels). This report describes the atmospheric decontamination system briefly but is concerned primarily with the vacuum systems

and, in particular, the F-201 vacuum glove chamber. The F-601 ultra-high-vacuum chamber will not be discussed in this report because it did not support the Apollo 11 and 12 missions directly. The basic operating team for the vacuum complex is described in the following sections.

As an aid to the reader, where necessary the original units of measure have been converted to the equivalent value in the *Système International d'Unités* (SI). The SI units are written first, and the original units are written parenthetically thereafter.

## Design Requirements

Design requirements for the F-201 high-vacuum sample-processing complex included quarantine requirements, scientific requirements to preserve the original condition of the lunar sample until its release to qualified investigators, and engineering requirements. The engineering requirements were necessary to accomplish the quarantine and scientific tasks.

## Quarantine Requirements

The prime quarantine requirement was the quarantine of the lunar material in the vacuum complex for a time period (approximately 60 days) during the testing of selected portions of the material for substances that might be harmful to animal or plant life. Also, the results of these tests were important in justifying the termination of the 3-week quarantine of the astronauts. The high-vacuum-processing complex is inherently suitable for quarantine operations because it operates at less than atmospheric pressure. Consequently, any leakage would result in material transfer into the system rather than outward. However, the requirement of testing the lunar sample for the presence of biological life necessitated that the vacuum systems be sterile on receipt of the lunar material. To be compatible with the vacuum environment and the scientific requirements, heat sterilization was chosen as the preferred method for the vacuum system. Other types of sterilization, such as formaldehyde or ethylene oxide, were undesirable because of residue that could contaminate the sample and limit the ultimate operating vacuum pressure. Both heat sterilization and peracetic acid sterilization were used in the atmospheric decontamination cabinets of the complex. These cabinets provided biocidal sterilization for all items entering and leaving the vacuum chambers. The exterior surfaces of sealed containers containing lunar samples being transferred out of the vacuum chambers or being returned to the vacuum chambers were sterilized by spraying the surfaces with peracetic acid in the R-102 cabinet (fig. 1). After a soak time of 30 minutes, the peracetic acid was removed by a sterile-water spray and a drying cycle was started. This procedure allowed the transfer of samples to other containment cabinets in different laboratory areas without exposing the sample to the damaging high temperatures necessary in heat sterilization. Additional tools or containers that required transfer into the vacuum processing chamber were heat sterilized at a minimum temperature of 433 K (160° C) for 4 hours in the B-302 oven.

The atmospheric decontamination cabinets (R-102, R-103, and R-302) were sterilized initially by soaking with peracetic acid before lunar-sample receipt. Before sample receipt, the interiors of the vacuum chambers and headers were sterilized by maintaining a minimum surface temperature of 393 K (120° C) for 24 hours at vacuum

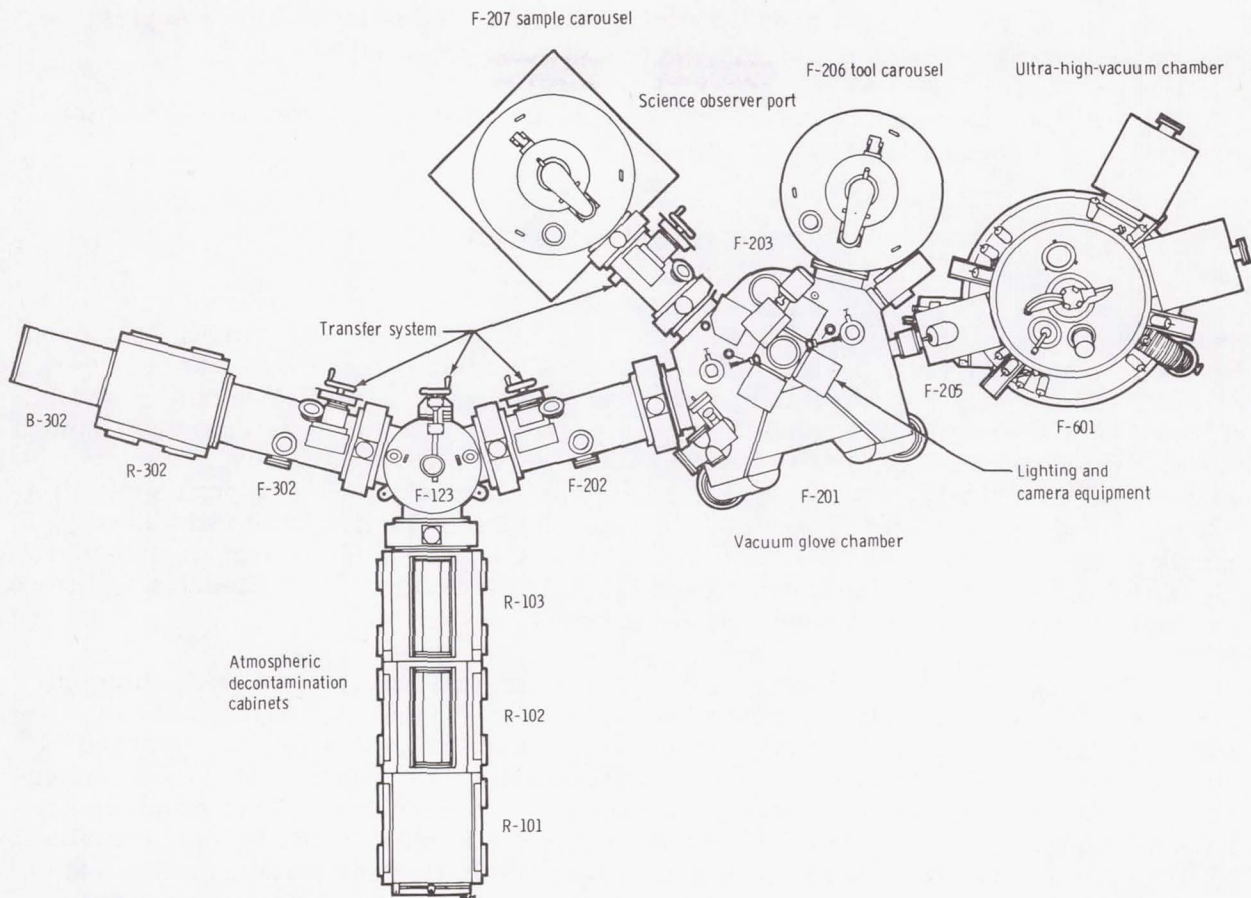

Figure 1.- The LRL high-vacuum complex.

pressures between  $133$  and  $0.133 \text{ mN/m}^2$  ( $10^{-3}$  and  $10^{-6}$  torr). This temperature was maintained by means of exterior surface heaters, thermal blankets, and thermocouples.

These procedures restricted any potentially harmful lunar organisms to the vacuum processing chambers, eliminated migration of Earth (terrestrial) organisms into the vacuum-chamber complex (and thereby prevented compromise of tests to detect lunar organisms in lunar samples), and allowed transfer of items to and from the vacuum-chamber complex.

### Scientific Requirements

Scientific requirements for the high-vacuum processing complex included the following.

1. Receive the returned containers and remove the samples.
2. Identify, catalog, and maintain complete histories of all samples.

3. Photograph, weigh, and make microscopic examinations of the samples, so that decisions can be made on the distribution of lunar material.

4. Maintain a sample-processing and storage environment compatible with preserving the original condition of the sample.

## Engineering Requirements

The engineering requirements were a direct result of the constraints imposed by the quarantine and scientific requirements. Because of the unknown qualities associated with lunar material, the original condition of the lunar samples had to be preserved. Consequently, a vacuum environment was chosen for initial sample processing. To further preserve sample condition and to provide an ultraclean vacuum environment, the materials to build the high-vacuum complex were selected carefully. The types of materials exposed to the sample had to be kept to a minimum, with emphasis on eliminating or reducing organic materials. In addition, the materials had to withstand sterilization temperatures of at least 393 K (120° C). The basic materials selected were stainless steel, Teflon (tetrafluoroethylene), aluminum, Viton (fluorinated hydrocarbon), Pyrex glass, and molydisulfide lubricant.

The time dependency of certain samples (biological and low-radiation samples) introduced some complexity into the vacuum-complex design. To expedite these samples, the initial design included two processing chambers so that the two returned sample containers could be processed simultaneously. To reduce costs, the same entrance cabinets and chambers were to be used for both chambers. This requirement necessitated an elaborate transfer system to direct the two returned sample containers to their respective processing chambers. After fabrication had started on the rest of the complex, a reduction of funds forced deletion of the requirement for the second glove processing chamber. Therefore, an unnecessary and complicated transfer system remained in the vacuum complex. Problems created by the transfer system are discussed elsewhere in this report.

To provide maximum flexibility in handling and processing lunar samples, an arm and glove assembly was chosen so that an operator could work directly in a  $0.133\text{-mN/m}^2$  ( $10^{-6}$  torr) vacuum environment. The initial concept was to use an arm and glove assembly patterned after the Apollo space-suit gloves. This assembly would have required an operator to work from a man-rated chamber so that the maximum pressure across the arm and glove assembly would be  $24.13\text{ kN/m}^2$  (3.5 psi). Safety and cost constraints and the feasible contractor development of a  $103.4\text{-kN/m}^2$  (15 psi) maximum-pressure arm and glove assembly eliminated this concept. The final design configuration was an arm and glove assembly that enabled the operator to perform tasks in the high-vacuum environment while remaining in a normal atmospheric environment.

To meet the requirements of a clean, sterilized, and controlled environment, unique constraints were imposed on the basic high-vacuum complex. To reduce the possibility of backstreaming of oils, which is common in vacuum diffusion pumps, cold-trapped turbomolecular pumps were chosen for pumping in the low- and medium-vacuum range during system pumpdown. For the high-operating-vacuum range, ion pumps



were chosen to maintain the high-vacuum environment in the complex. The chambers were isolated by electrically operated valves from the turbomolecular pump headers. An ion pump does not require a forepump to pump the collected gases to atmospheric pressure because the ionized gases are trapped on the anode surface of the pump. Hence, a closed system is maintained with less chance of outside contamination.

Additional design requirements were tools that the glove operator could manipulate while handling the lunar sample without contaminating the sample or the environment and a system in which detailed photographic and microscopic studies could be conducted.

## VACUUM SAMPLE-PROCESSING COMPLEX DESCRIPTION

The components of the LRL vacuum sample-processing complex are the F-201 vacuum glove chamber, the vacuum transfer chambers (locks), the vacuum storage chambers (carousels), the atmospheric decontamination cabinets, the F-601 ultra-high-vacuum chamber, and a control console. The vacuum-complex layout is shown in figure 1. Figure 2 is a schematic of the complex. In figure 3, the complex control console is shown in the foreground and part of the vacuum complex (two storage carousels and camera control station platform) is shown in the background.

### F-201 Vacuum Glove Chamber

The F-201 vacuum glove chamber (fig. 4) is the sample-processing chamber. The chamber provides the capability for handling items being processed using an arm and glove assembly. In addition, provisions are made for sample photography, microscopic examination, transfer, sample weight determinations, and gas analysis.

Basic chamber operating team. - The basic operating team for the F-201 vacuum glove chamber is composed of the following personnel, who perform the functions noted.

1. A technician, or glove operator, performs manipulative tasks within a hard vacuum ( $0.133 \text{ mN/m}^2$  ( $10^{-6}$  torr)) by means of an articulated anthropomorphic arm and glove assembly while working unencumbered at atmospheric pressure.
2. An alternate glove operator rotates with the glove operator in performing manipulative tasks in the chamber and acts as an extra observer for the glove operator.
3. A scientific observer, located on the opposite side of the chamber from the arm and glove operator, observes activity from a glass port on the chamber top. His functions are to observe and provide instruction in handling the lunar sample and to make microscopic examination of the sample through his port.

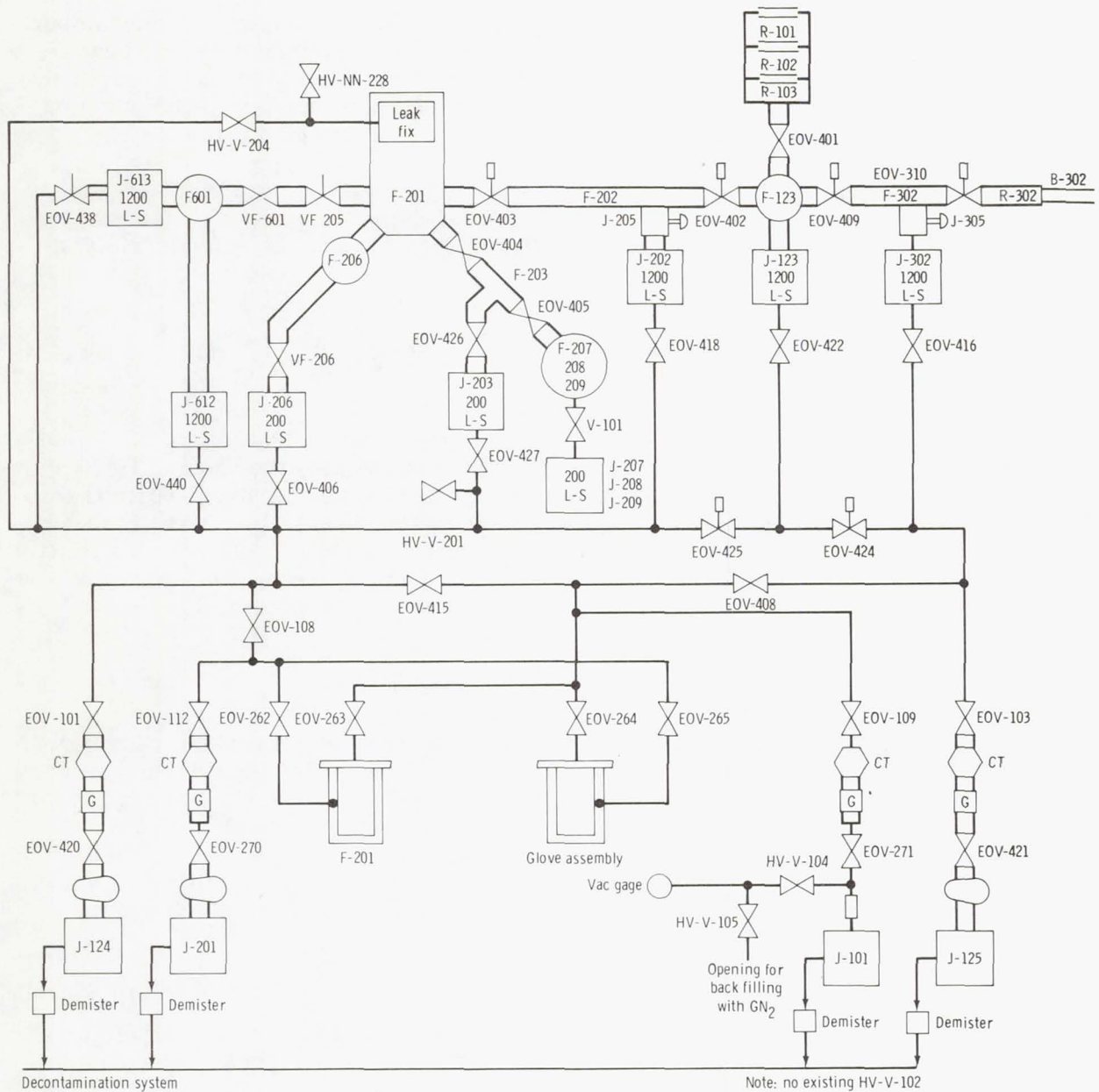

B-302 = oven  
 CT = coldtrap  
 EOV = electronically operated pump  
 F-123 = pressure-equalization chamber  
 F-201 = vacuum glove chamber  
 F-202 = glove chamber transfer lock  
 F-203, F-302 = transfer locks  
 F-206 = tool carousel  
 F-207, F-208, F-209 = sample carousels  
 F-601 = ultrahigh-vacuum cabinet  
 G = gas filter  
 GN<sub>2</sub> = gaseous nitrogen

HV-NN = hand valve, gaseous nitrogen  
 HV-V = hand valve, atmospheric backfill  
 J-101 = roughing pump  
 J-123, J-203, J-206, J-207, J-208, J-209,  
 J-302, J-612, J-613 = ion pumps  
 J-124, J-125, J-201, J-204 = turbomolecular pumps  
 J-205, J-305 = titanium sublimator pumps  
 L-S = liter/sec  
 R-101, R-102, R-103, R-302 = atmospheric  
 decontamination cabinets  
 V = vacuum valve  
 VF = hand valve  
 Vac = vacuum

Figure 2. - A schematic diagram of the LRL high-vacuum complex.



Figure 3.- High-vacuum-complex control console.

4. A cameraman, located on a platform above the chamber, controls the chamber elevator platform for microscopic and photographic functions. By moving the sample into an optical "penthouse" above the chamber, the cameraman may take record, contour, and stereoscopic photographs of the six sides of the sample.

5. A sample-process controller monitors chamber activity (by means of television monitors), monitors vacuum instrumentation, provides control for transfer in the vacuum complex, advises the scientific observer, and provides instruction to the glove operator on the implementation of tools, containers, and procedures.

Glove chamber description. - The F-201 vacuum glove chamber has an approximately pentagonal form, four sides of which are connected to other vacuum chambers. The F-201 chamber is approximately 74 centimeters (29 inches) high, 147 centimeters (58 inches) wide, and 140 centimeters (55 inches) deep, and the chamber is constructed of 300-series stainless steel. The glove operator area of chamber F-201 without the installation of the glove assemblies or operator optical port is shown in figure 5.

The F-201 chamber is isolated from the F-202 transfer lock by a 40.64-centimeter (16 inch) gate valve, from the F-203 transfer lock by a 30.48-centimeter (12 inch) valve, and from the F-205 transfer lock by a 10.16-centimeter (4 inch) ultra-high-vacuum valve. Also, the chamber is attached to an F-206 tool carousel.

The vacuum glove chamber contains six 20.32-centimeter (8 inch) photographic sight ports, a 12.70-centimeter (5 inch) closed-circuit-television sight port, and two 12.70-centimeter (5 inch) observation ports. Also provided are a 21.59-centimeter (8.5 inch) microscope sight port and two 1.27-centimeter (0.5 inch) ports for gas-analysis-system attachment.

The major components of the vacuum glove chamber are arm and glove assemblies (fig. 6), a weighing system, a camera and microscope control, and a control console. The glove assembly consists of right and left arm and glove units that are made of stainless steel and lined with polyurethane. The arm and glove units have movable joints to give mobility with minimum exertion by the operator. The glove thumb, fingers, and part of the hand are fabricated of nylon; the fingertips are impregnated with polyurethane. Each arm and glove unit is covered with a Viton A overglove that is attached to the inner wall of the F-201 glove chamber. The inner-glove arms are attached to a 26.67-centimeter (10.5 inch) diameter flange on the F-201 glove chamber. The mounting flange is sealed with a Viton A O-ring.

The interstitial space between the pressure glove and the Viton overglove is evacuated through the inner and outer walls of the F-201 glove chamber by the J-201 turbomolecular pump. The low pressure retards leakage through the gloves into the F-201 glove chamber and also prevents "ballooning" of the Viton overglove when the F-201 glove chamber is at a pressure of  $0.133 \text{ mN/m}^2$  ( $10^{-6}$  torr). The glove assembly will withstand a  $101.35\text{-kN/m}^2$  (14.7 psi) differential pressure with a leak rate of less than  $50 \text{ cm}^3/\text{min}$  for each arm and glove unit. All glove assembly components are compatible with a vacuum environment to a pressure of  $13.3 \text{ }\mu\text{N/m}^2$  ( $10^{-7}$  torr). The evacuation of interstitial space is simultaneous with the evacuation of the F-201 glove chamber.

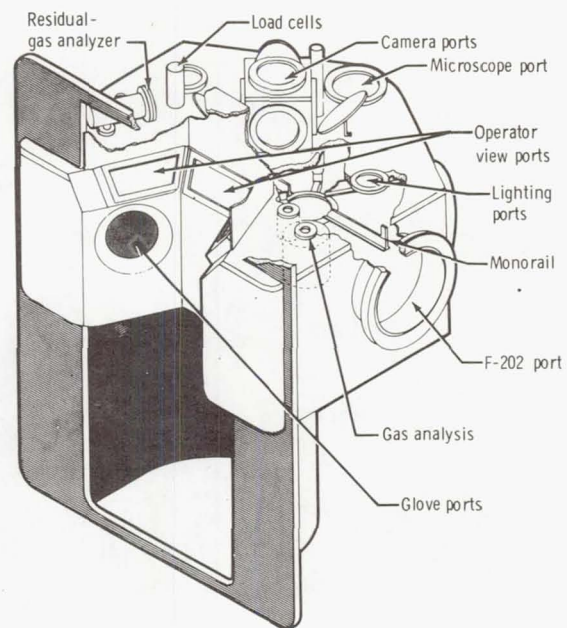

Figure 4.- The F-201 vacuum glove chamber.

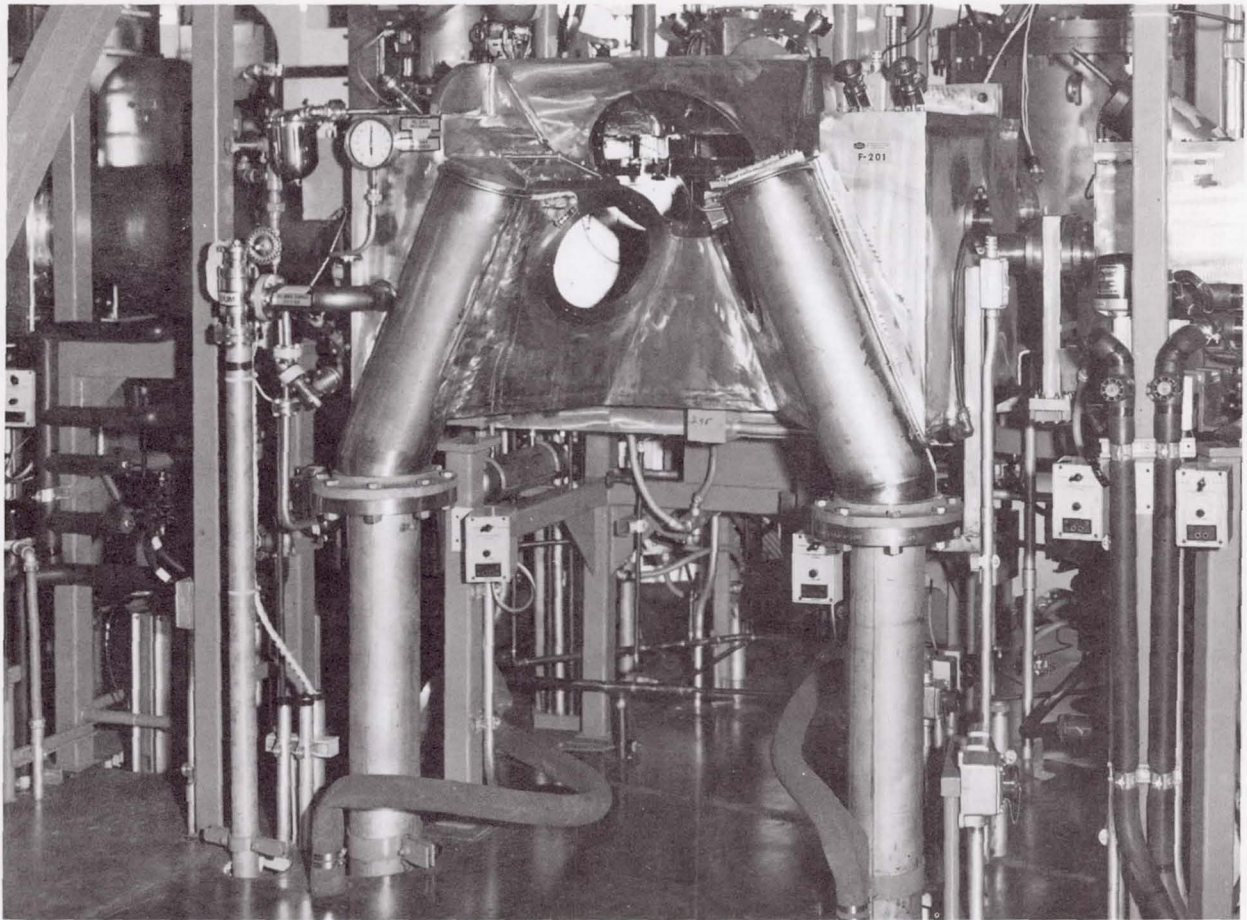

Figure 5. - The glove operator area of chamber F-201.

The weighing system in the F-201 glove chamber is used to weigh items ranging from 0 to 10 kilograms. The load cell system is located in the top left side of the F-201 glove chamber (fig. 4). All surfaces exposed to a vacuum are constructed of stainless steel. The weighing system consists of a multirange force transducer, a readout instrument, and associated controls.

The camera operator uses the camera-control station to position the lunar-sample elevator for photographing side views of the lunar sample. The control station platform above the F-201 chamber (the background of fig. 3) consists of cameras, light projectors, and elevator controls. Figure 7 is a photograph of an Apollo 11 lunar sample taken with this system.

## Vacuum Transfer Chambers

The vacuum transfer system consists of the F-123 pressure-equalization chamber and the F-202, F-302, and F-203 transfer chambers (fig. 1). The purpose of the transfer system is to facilitate transfer between the atmospheric decontamination cabinets and the F-201 vacuum glove chamber, and between the F-201 glove chamber and the sample-storage carousel. The transfer is achieved by use of the surface-mounted extensor-monorail system. The monorail system has an inverted T-shaped configuration and is constructed of 300-series stainless steel. The extensor system consists of the extensor sprocket (controlled by the externally mounted handwheel) and the extensor pushrod assembly. The pushrod assembly consists of a Teflon bar (182.88 to 243.84 centimeters (72 to 96 inches) long with a 0.95-by 0.95-centimeter (0.375 by 0.375 inch) cross section) and a stainless-steel latching rod. For transfer of items between two chambers, the extensor pushrod assembly is operated by turning the externally mounted handwheel, either clockwise or counterclockwise. The latching rod either pulls or pushes the sample basket between the two chambers.

The F-123 pressure-equalization chamber is an intermediate or staging chamber that permits items to be transferred between the decontamination cabinets at ambient pressures and either the F-202 or the F-302 transfer lock at pressures of  $0.133 \text{ mN/m}^2$  ( $10^{-6}$  torr). The F-123 chamber is constructed of 304 stainless steel and is 66.04 centimeters (26 inches) in diameter by 81.28 centimeters (32 inches) in length. The chamber has three 40.64-centimeter (16 inch) valves that connect it to the R-103 decontamination cabinet, the F-202 chamber, and the F-302 chamber. The F-123 monorail can be rotated for transfer to or from the atmospheric decontamination cabinets, the F-202 chamber, or the F-302 chamber.

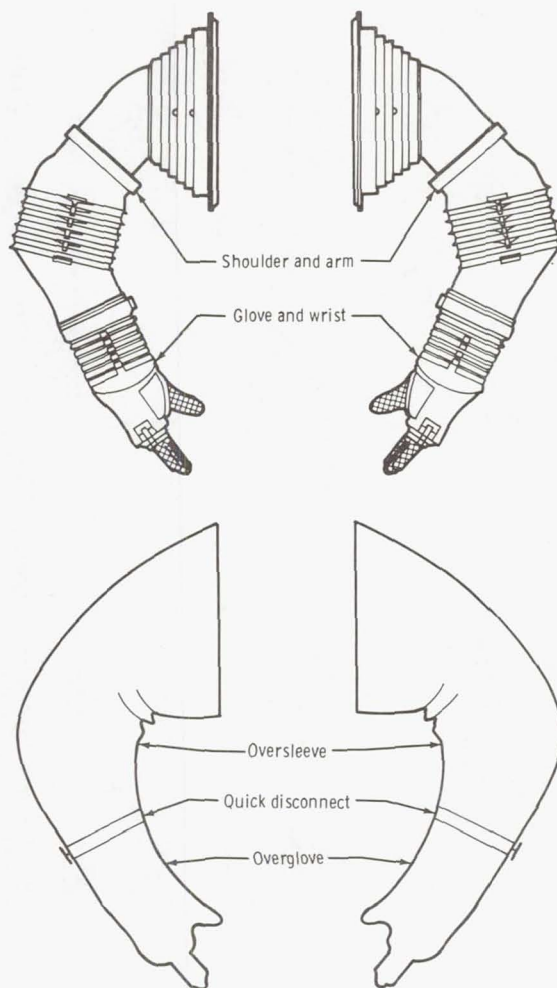

Figure 6.- LRL  $101.3\text{-kN/m}^2$   
(1 atmosphere) arm/glove  
system.

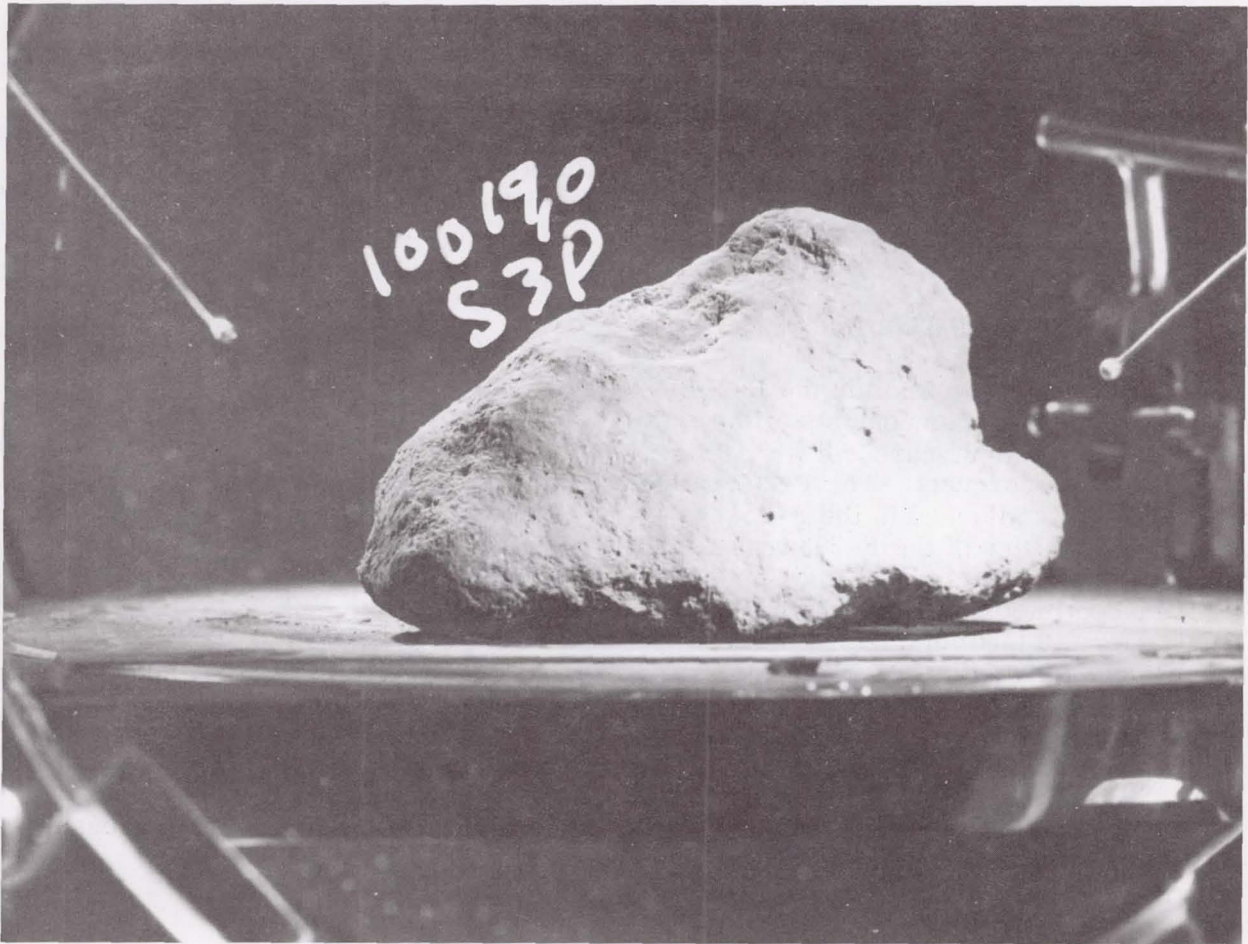

Figure 7.- Apollo 11 lunar sample.

The F-202 transfer chamber is used to transfer items between the F-123 pressure-equalization chamber and the F-201 glove chamber while maintaining the operating pressures. The F-202 chamber includes the primary pumping system for the F-201 glove chamber. The F-202 chamber is a 304 stainless-steel vacuum chamber that is 40.64 centimeters (16 inches) in diameter and 96.52 centimeters (38 inches) long and is equipped with a titanium sublimator pump, a 1200-liter/sec ion pump, and a monorail-extensor system for moving items between the F-123 and F-201 chambers.

The F-302 transfer chamber is an intermediate storage chamber, between the atmospheric decontamination cabinet R-302 and the F-123 pressure-equalization chamber, used for the sample return containers and other sample containers. The F-302 chamber, located on the opposite side of F-123 from F-202 (fig. 1), is identical in size and function to the F-202 chamber and provides a backup pumping station for the sample-processing complex.

The F-203 transfer chamber is 30.48 centimeters (12 inches) in diameter by 53.34 centimeters (21 inches) in length. This chamber is a stainless-steel cylinder containing a 200-liter/sec ion pump, a pumping port, and 30.48-centimeter (12 inch) isolation valves. The chamber permits the transfer of items between the F-201 glove chamber and the F-207 carousel (fig. 8) without altering the working pressure of either vessel. Also, the F-203 chamber allows sample carousel replacement by isolation and sterilization.

## Vacuum Storage Chambers

The storage system for the F-201 vacuum glove chamber consists of the mobile F-207 sample carousel (fig. 8) and the F-206 tool carousel. The F-207 sample carousel is attached to the F-201 chamber by means of the F-203 transfer lock. The sample carousel is composed of a 91.44-centimeter (36 inch) high, 101.6-centimeter (40 inch) diameter stainless-steel tank, a 200-liter/sec ion pump, an adjustable-height dolly base, an elevator-drive subassembly, and a spider subassembly.

The dolly base rolls on four casters and is equipped with a handwheel that operates four screwjacks to raise or lower the carousel tank in fitting the carousel to the F-203 chamber. The ion pump maintains a vacuum inside the carousel when it is detached from the rest of the vacuum complex. This system allows the removal of a carousel when its storage capacity is exceeded and the attachment of an empty carousel to the complex.

Sample containers (figs. 9 and 10) and dollies (figs. 11 and 12) are stored on the spider subassembly and positioned by the elevator-drive subassembly. The carousel spider subassembly consists of two tiers of 12 monorails each. The monorails radiate from the spider main shaft and are used as storage racks for sample dollies. To facilitate sample transfer, the desired tier is positioned vertically for alignment to the chamber entrance and then rotated to the desired monorail position. The 24 monorail positions are selected and controlled electrically from the complex control console through the elevator-drive assembly.

The F-206 carousel serves as a tool-storage carousel while maintaining the tools in the  $0.133\text{-mN/m}^2$  ( $10^{-6}$  torr) pressure range. The tool carousel is attached to the F-201 glove chamber. The tool carousel is similar to the sample carousel except that the tool carousel is not movable and is attached to the F-201 glove chamber vacuum header.

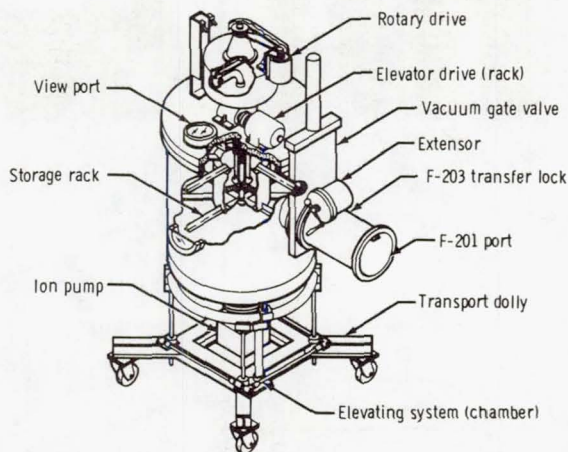

Figure 8. - The F-207 sample carousel.



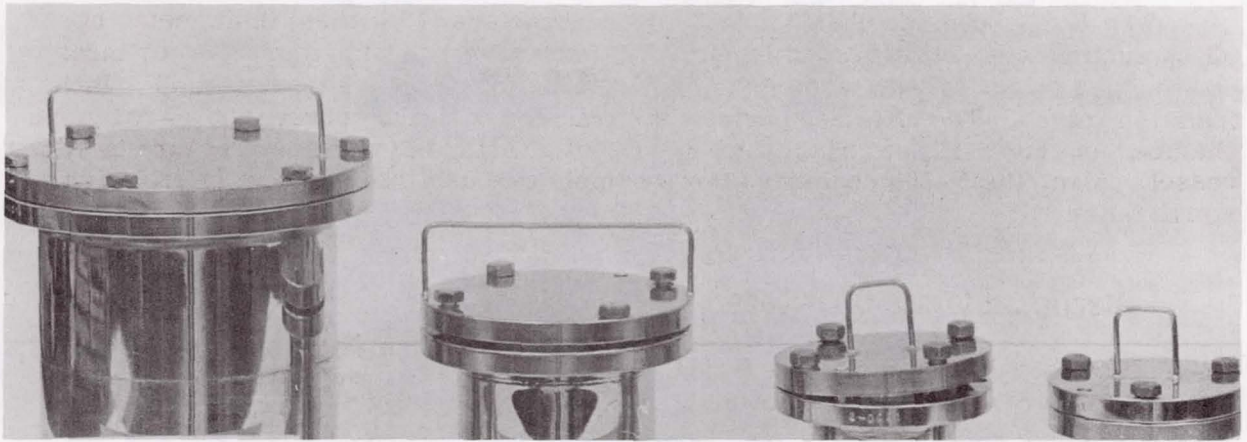

Figure 9.- Bolt-top sample containers.

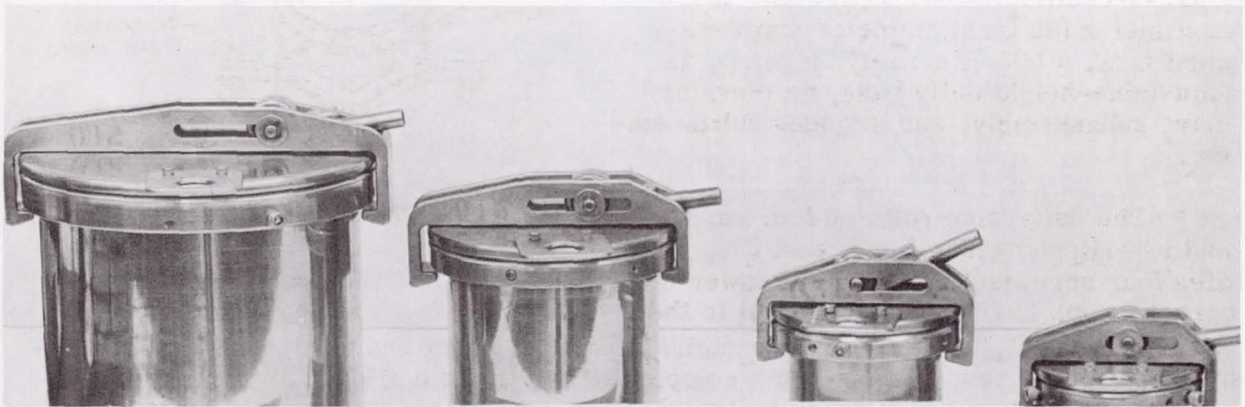

Figure 10.- Single-action sample containers.

### Atmospheric Decontamination System

The atmospheric decontamination system (fig. 1), which consists of five atmospheric cabinets, is used to decontaminate items biologically that are entering and leaving the vacuum complex. The system function is described in the section entitled "Quarantine Requirements." Although this report is not concerned directly with quarantine problems associated with the returned lunar samples, a brief description is given of this system.

Items entering or leaving the complex vacuum chambers may pass through one of two decontamination branches. The heat-sterilization branch, consisting of the B-302 oven and the R-302 atmospheric handling cabinet, terminates at the F-302 vacuum transfer chamber. The peracetic-acid-sterilization branch (consisting of the R-101 airlock cabinet, the R-102 sterilization cabinet, and the R-103 drying cabinet) terminates at the F-123 vacuum transfer chamber.

All the cabinets contain a nitrogen environment at slightly less than atmospheric pressure. The specific functions for each cabinet are as follows.

1. R-101: Acts as an airlock and provides nitrogen purge

2. R-102: Provides surface sterilization with peracetic acid soak and then flushes the surface with sterile-water spray

3. R-103: Provides hot gaseous-nitrogen purge for drying items before entry into the F-123 vacuum chamber

4. B-302: Provides sterilization temperatures as high as 433 K (160° C)

5. R-302 (sterilized handling cabinet): Facilitates transfer of items between the F-302 vacuum chamber and the B-302 oven

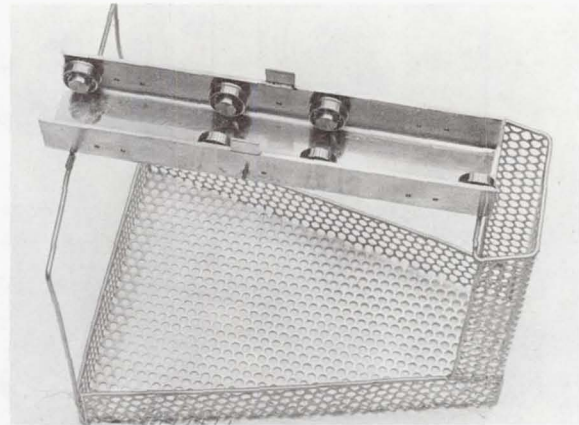

Figure 11.- Dolly and basket.

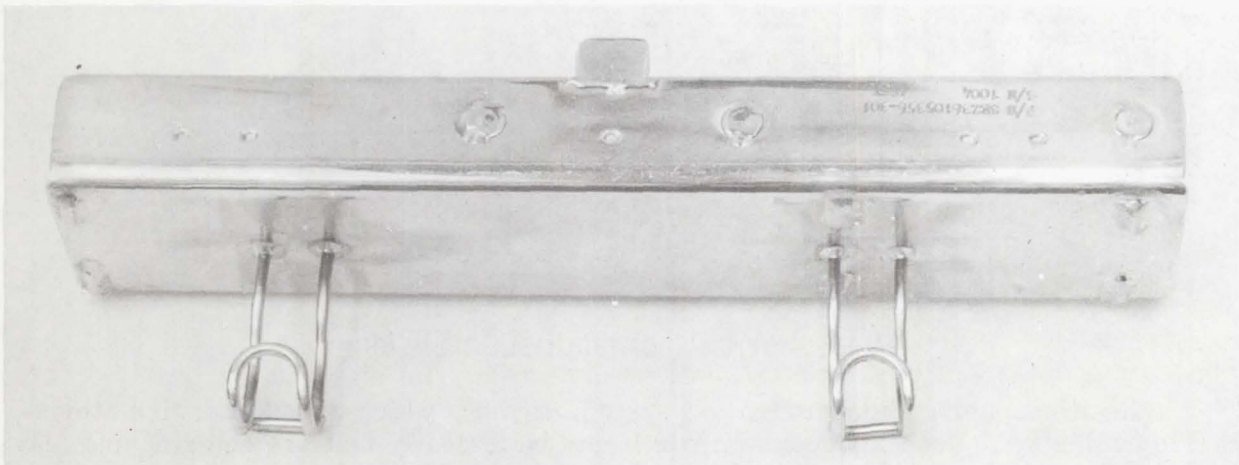

Figure 12.- Sample container dolly.

### F-601 Ultra-High-Vacuum Chamber

Although the F-601 ultra-high-vacuum chamber did not support Apollo 11 or 12 lunar-sample processing directly, a brief description is inserted here because it is part of the LRL high-vacuum complex. Special ultra-high-vacuum samples, contained in a special environmental sample container (SESC), are passed from chamber F-201

to F-601 (fig. 1), which is a double-walled differentially pumped chamber that operates in the 133- to  $1.33\text{-nN/m}^2$  ( $10^{-9}$  to  $10^{-11}$  torr) region. A mechanical manipulator and a rotary table allow the operator to open the sample container, to subdivide the samples, and to store the samples in individual containers that are called appendages. Each appendage has its own battery-operated ion pump to permit shipment of lunar samples to scientific investigators while maintaining an ultra-high-vacuum environment (133 to  $1.33\text{ nN/m}^2$  ( $10^{-9}$  to  $10^{-11}$  torr)). After the Apollo 12 quarantine period (approximately 60 days), an Apollo 12 SESC was processed successfully in this manner in the LRL high-vacuum complex. The F-601 chamber is pumped out by the use of a turbomolecular pump, a sputter ion pump, an electrostatic ion pump, and a cryogenically cooled wall.

## Control Console

The entire LRL high-vacuum complex is operated and monitored from the control console (fig. 3). This console provides continuous monitoring and recording of all vacuum-chamber pressures (from atmospheric to  $13.3\text{ }\mu\text{N/m}^2$  ( $10^{-7}$  torr)) in the complex. Television monitors provide the operator with the procedural status in the F-201 chamber. Control of chamber valves and transfer systems is provided by the use of electronically operated valve actuators and a lighted graphic display of the vacuum complex.

## DEVELOPMENT AND OPERATIONAL DIFFICULTIES

### Maintenance of the Vacuum Environment

The vacuum system is inherently an excellent quarantine facility because a barrier break would result in an inward flow into the system. The inward flow would reduce the probability of migration of harmful lunar pathogens from the system. In addition, a highly reliable system was needed for lunar quarantine. That is, sample receipt prevented normal system maintenance because of the potentially hazardous lunar material. A malfunctioning system component would have to be either isolated, sterilized, and repaired or isolated and left inoperative until the end of lunar-sample quarantine. For example, a malfunctioning vacuum pump would be deactivated and left in that condition until the end of sample quarantine because of the difficulties in sterilization of these pumps. Procedures were generated that allowed other vacuum pumps in the system to absorb the functions of the inoperative pump with a slight loss in flexibility. A defective component in a section of the header would be repaired by means of isolating the section from the rest of the system (by valve closures), heat sterilizing to kill any lunar organisms, repairing or replacing the defective components, heat sterilizing to kill any terrestrial organisms that were accumulated during repair, and opening the repaired section to the rest of the system. Anomalies with the turbomolecular vacuum pumps were troublesome, particularly before the Apollo 11 lunar-sample processing.

Before the Apollo 11 sample-processing checkout and simulations, oil migration from the pumps to the vacuum chambers occurred, particularly during bakeout of the vacuum complex. Investigation revealed the following sources of the problem.

1. Excessive atmospheric backfilling of the turbomolecular pumps
2. Ineffective coldtrapping by the pumps
3. Irregular preventive maintenance of the pumps
4. Migration of oil vapors during high-temperature bakeout

During initial system buildup, which continued almost to the Apollo 11 launch, the vacuum chambers had to be raised to atmospheric pressure for repair or modifications. The initial procedure was to backfill the complete vacuum complex from gaseous-nitrogen inlets in the pump area. The correlation between oil contamination in the vacuum chambers and the number of times the vacuum complex was backfilled was noted. The nitrogen gas flowing past the liquid-nitrogen coldtraps created a warming effect on the traps and thus released oil vapors that were carried into the chambers. Closely associated with this problem was the manual method of filling the nitrogen coldtraps of the pumps by means of a dewar. The temperature of a properly filled coldtrap would be maintained for a maximum of 2 hours. Occasionally, a coldtrap warmed up before the allocated time and released trapped oil vapor because the trap was filled improperly or because an excessive gas load from the vacuum complex depleted the liquid nitrogen at a faster than normal rate. An indication of this early warmup was a sudden rise in header pressure. Also, the manual filling method expended excessive manpower to service the traps because the dewar had to be filled at a remote station, transported, and connected to the individual pumps.

The approach taken to correct the liquid-nitrogen filling problem was to substitute a fully automatic filling system. This approach included running insulated liquid-nitrogen lines to the coldtraps and installing a liquid-nitrogen sensing control unit. The method was not completely acceptable because, during the time that no liquid nitrogen was ordered by the sensing control unit, the liquid nitrogen in the supply lines would warm and convert to pressurized gaseous nitrogen. Safety pop-off valves were installed in the event the gaseous-nitrogen pressure became too great. Then, when additional liquid nitrogen was ordered by the sensing control unit, the occurrence of a turbulent flow of gaseous/liquid nitrogen resulted in splashing the liquid nitrogen on the sensing control unit and closing the coldtrap inlets with an inadequate amount of liquid nitrogen in the coldtraps. Also, this turbulent flow caused external liquid-nitrogen leakage at the coldtrap inlets.

Rather than make the automatic filling system more complex to correct the problems and because at least one man was always present when the pumps were operating, a compromise between the completely manual and the completely automatic filling systems was developed.

A bypass line was added at each inlet to each liquid-nitrogen coldtrap, and an overflow line was installed at each coldtrap. Both lines terminated in a single storage vessel. To fill each coldtrap, the operator opened the valve to the bypass line and

observed the flow until only liquid nitrogen (no gaseous nitrogen) was flowing into the storage vessel. The operator then closed the bypass line and opened the inlet to the coldtrap. He observed the overflow line until liquid-nitrogen flow occurred and then terminated the liquid-nitrogen flow to the coldtrap. As experience was gained, the operators were able to adjust the inlet nitrogen flow to each coldtrap so that a trickle of liquid nitrogen from the overflow line into the storage vessel would ensure that the coldtrap had a full liquid-nitrogen level. This ability was useful particularly during such peak gas-load periods as temperature bakeout of the complex. This filling method required minimum effort by the pumproom operator.

Several procedural changes were incorporated to further reduce excessive gas loads on the liquid-nitrogen coldtraps during the backfilling of the pumps for modification of the vacuum chambers.

The first and most important change was to eliminate the frequent backfilling of the pumps to atmospheric pressure. Rather than backfilling the vacuum complex from the pump area, the pumps were isolated from the complex by valves just above the liquid-nitrogen coldtraps, and the pumps continued pumping on the isolated coldtrap section. The backfilling then proceeded from the chamber area so that nitrogen flow was toward the pump area. This procedure further reduced the possibility of airborne contamination to the chamber area.

The vacuum complex was pumped down by roughing with a single coldtrapped 1.42-m<sup>3</sup>/min (50 ft<sup>3</sup>/min) pump for the low-vacuum range. This pump is isolated at a pressure of 133 N/m<sup>2</sup> (1 torr), and the turbomolecular pumps open again to the vacuum complex to continue the pumpdown sequence. Thus, the turbomolecular pumps were never exposed to higher pressures than operating pressures. Also, this procedure increased the mechanical reliability of the pumps.

During simulations before the Apollo 11 sample processing, frequent failures of atmosphere seals in the pumps were noted. These failures resulted in excessive oil levels in the pumps because additional oil was added to the pumps to replace oil that leaked past the atmospheric seals. This condition would have been intolerable during an Apollo mission; therefore, a detailed, regular preventive maintenance program was started for the pumps. In addition, as part of the premission operations, the pumps were overhauled completely. Consequently, no vacuum-pump failures occurred during Apollo mission operations.

To eliminate the possibility of oil-vapor migration during the high-temperature bakeout of the vacuum complex, the vacuum-pump headers were maintained at a slightly lower temperature so that any migration would remain in the header area (i. e., the oil would collect on the cooler surfaces). In addition, a temporary liquid-nitrogen coldtrap was installed in the glove chamber through a glove port to condense and collect any organic oil vapors in that area. After bakeout, liquid-nitrogen flow to the chamber coldtrap and the header coldtraps was maintained until these items were removed from the complex for cleaning. The header coldtraps were then reinstalled. This procedure prevented the liberation of trapped organics back into the vacuum complex. Because these procedures were used, the organic background in the F-201 complex during the Apollo 11 and 12 sample processing was less than 1 p/m.

The major problem associated with maintenance of the vacuum environment was the lack of time at vacuum pressures to enable purging of outgassing material from chambers. Between February 1, 1969, and the launch date of the Apollo 11 mission (July 16, 1969), three major mission simulations were conducted with the vacuum complex. Because of the time spent in preparing for simulation (cleaning chambers before and after each simulation, loading and unloading tools) and the time spent in solving problems identified during the simulations, the vacuum complex was at atmospheric pressure during most of the 5.5-month period. For a vacuum system, the time to reach a low operating pressure is directly proportional to the time spent exposed to atmospheric gases. Simply, this is the time necessary to pump the monolayers of atmospheric gases absorbed in the metal surfaces of the chambers. These gases absorbed by the metal during atmospheric exposure are outgassed at vacuum pressures and, for a leaktight system, are the predominant constraint in reaching vacuum pressures less than  $133 \text{ mN/m}^2$  ( $10^{-3}$  torr). Hence, even with the vacuum bakeout, a week of pumping time on the complex was required to reach the minimum operating pressure of  $0.133 \text{ mN/m}^2$  ( $10^{-6}$  torr) for the Apollo 11 sample processing. In transferring items from the atmospheric decontamination cabinets to the F-201 processing chamber, 3 to 4 hours were required for the F-123 pressure-equalization chamber pumpdown at the beginning of the Apollo 11 sample processing.

Few modifications were made to the vacuum complex between the Apollo 11 and 12 sample-processing periods because of the short time between the end of sample processing of Apollo 11 material and the launch of the Apollo 12 spacecraft. The vacuum complex was maintained either at vacuum or purged with dry gaseous nitrogen during most of this period. Consequently, by the end of the Apollo 12 sample processing, the time required for the F-123 pressure-equalization chamber pumpdown was only 10 to 15 minutes. This reduction in pumpdown time greatly accelerated the transfer of items to and from the F-201 vacuum glove chamber and eliminated the necessity for expending manpower to provide parallel processing and transfer operations for timely sample processing.

Between the Apollo 12 and 14 missions, no interior modifications of the vacuum glove chamber were made, and the chamber either was held at vacuum or purged with dry gaseous nitrogen to minimize exposure to atmospheric gases. Consequently, a system (outgassed) pumpdown of less than 4 hours was needed to reach base pressure (between  $13.3$  and  $1.33 \text{ } \mu\text{N/m}^2$  ( $10^{-7}$  and  $10^{-8}$  torr)) in the vacuum complex. During processing of samples after the Apollo 11 and 12 missions (the summer and fall of 1970), the short test pumpdown times allowed the sample personnel to assist in chamber processing and vacuum transfer operations without impeding the timely sample processing. Operational communications problems were greatly reduced and operational reliability was increased.

A consequence of the prolonged pumpdown of the vacuum complex before the Apollo 11 sample processing was failure of the ion pumps. All the large ion pumps had to be replaced before the Apollo 11 sample processing. The life cycle of an ion pump is directly proportional to the minimum operational pressure. For example, the life of an ion pump is approximately 32 000 hours at  $0.133 \text{ mN/m}^2$  ( $10^{-6}$  torr) and is approximately 320 hours at  $13.3 \text{ mN/m}^2$  ( $10^{-4}$  torr). After the vacuum-complex configuration

had stabilized and the complex had time to purge, the pumps were in the 13.3- to 1.33-mN/m<sup>2</sup> (10<sup>-4</sup> to 10<sup>-5</sup> torr) range for only a few minutes. Only one large ion pump was replaced after the Apollo 11 sample processing; this replacement was caused by inadequate repairs in the pump the first time it was replaced.

## Arm and Glove Assembly

The arm and glove assembly (figs. 6 and 13 to 16) was the feature that gave a unique character to the F-201 vacuum processing complex, but the arm and glove assembly problems also provided the widest publicity. The arm and glove assembly was the heart of the lunar-sample processing complex. No lunar-sample processing could occur without the use of these gloves; therefore, the problems associated with the gloves were a reflection of the readiness status of the complete complex. Failure of the arm and glove assembly usually resulted in a dynamic implosion of the vacuum system. Procedures were written and operators trained to respond quickly to this type of failure so that an arm and glove assembly failure would not compromise the "quarantine barrier." These precautions were successful. Development of an adequate arm and glove assembly continued through both the Apollo 11 and 12 sample processing.

Two major tasks were associated with the arm and glove assemblies developed under a research and development contract for NASA. The contractor was to develop a reliable glove that would not only withstand the 103.4-kN/m<sup>2</sup> (15 psia) pressure differential across the arm and glove assembly but also provide maximum flexibility in handling the sample in the vacuum glove chamber.

During simulations conducted in February and March 1969, failures occurred in the thumb area of the 103.4-kN/m<sup>2</sup> (15 psia) pressure glove. The chamber glove operators complained that the thick, oversized Viton overgloves greatly reduced operational flexibility and that a metal ridge restraint around the pressure-glove thumb limited thumb movements.

Development efforts were initiated to correct these problems. For the Apollo

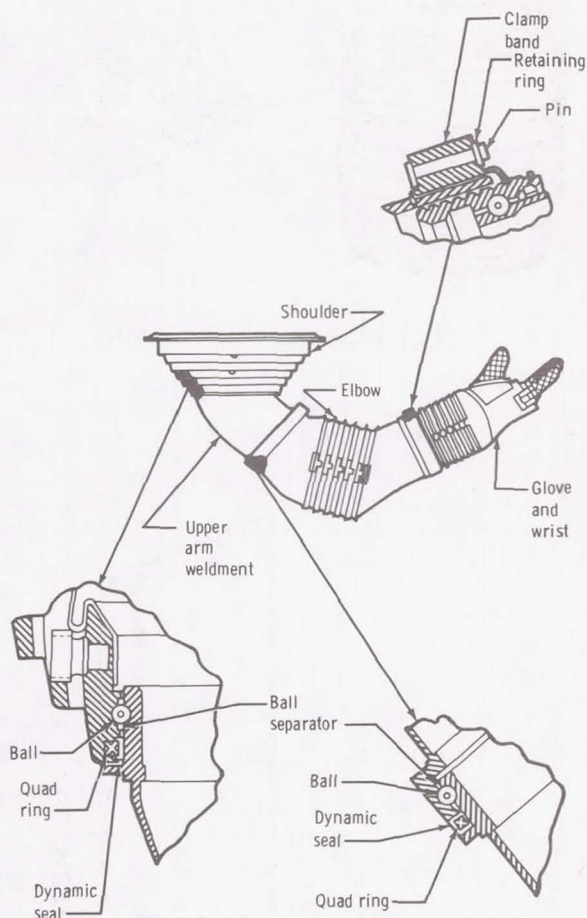

Figure 13.- Shoulder, arm, and glove assembly.

11 sample processing, overgloves that had been dipped were received, and these gloves had mandrels approximately the size of the pressure gloves. These smaller, Viton-covered overgloves were lined with silicone to provide strength to the thin Viton covering. Unfortunately, these overgloves and arm assemblies did not arrive until 2 weeks before the Apollo 11 launch; therefore, no time was available for operational qualification tests.

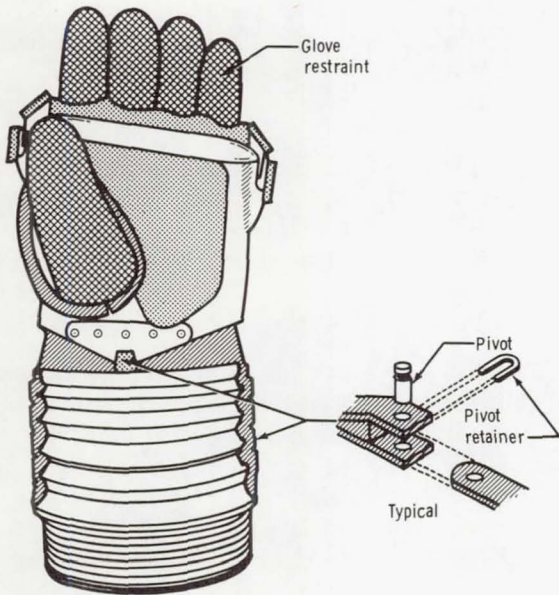

Figure 14.- Glove and wrist assembly.

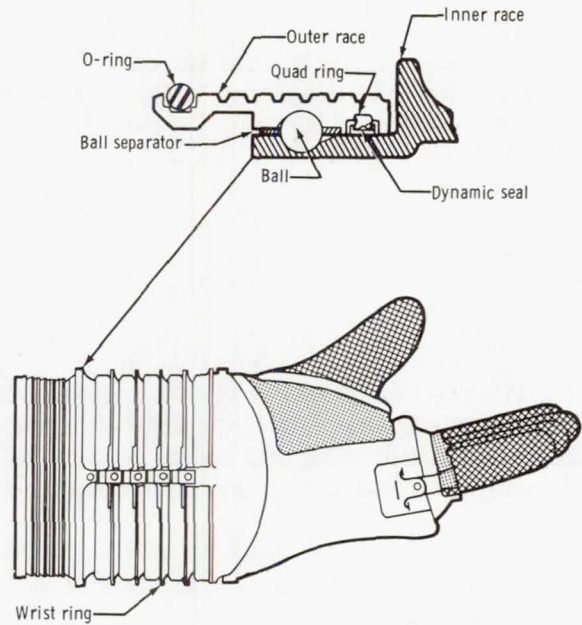

Figure 15.- Side view of glove and wrist assembly.

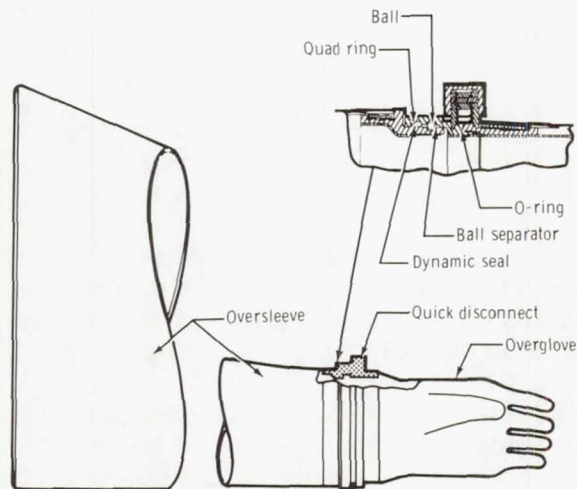

Figure 16.- Overglove sleeve and glove assembly.



Complete redesign of the pressure gloves was initiated after the gloves failed in the February and March simulations. To provide greater strength and flexibility, a nylon slip-net system, developed by another contractor, was incorporated into the fingers and thumbs of the pressure gloves. This net system consisted of two layers of nylon woven at right angles to each other in the finger and thumb areas (figs. 14 and 15).

This combination of pressure glove and overglove was used for processing Apollo 11 samples in the F-201 vacuum glove chamber. The untested overglove began to disintegrate during the initial handling of the sample container, and this disintegration exposed the nylon webbing of the pressure glove. Efforts by the glove operators to prevent contact of the nylon webbing by using tools and containers and to proceed with useful tasks in the chamber were extremely difficult. However, sample processing was continued to obtain the necessary biological samples to facilitate quarantine release. An extra pair of overgloves was cut from the wrist joints and transferred into the F-201 vacuum glove chamber after the "bioprime" sample had been sealed and transferred out of the system. These overgloves, which were taped into place over the damaged gloves by the glove operator, also began to develop holes. This exposure of the chamber to the higher pressure in the interstitial pumping space between the glove and the overglove resulted in chamber pressures in the  $1.33\text{-mN/m}^2$  ( $10^{-5}$  torr) range. Continued exposure of the pressure gloves to working surfaces in the chamber resulted in an implosion when the nylon webbing failed on the right thumb 5 days after receipt of the first Apollo lunar-sample return container (ALSRC).

To change the damaged glove assembly, the complete vacuum processing complex was heat sterilized (with the exception of the F-207 sample carousel and its lunar sample). This process was necessary to prevent migration of potentially harmful lunar organisms from the complex. All the lunar samples in the F-201 vacuum glove chamber at the time of the implosion were sterilized.

As a result of these arm and glove assembly failures, a glove failure analysis team was established by the NASA Lyndon B. Johnson Space Center (JSC) (formerly the Manned Spacecraft Center (MSC)) to aid the LRL personnel in an attempt to provide a more reliable arm and glove assembly.

For the Apollo 12 sample processing, emphasis was centered on design and fabrication of improved overgloves. The two-layer overglove was eliminated. A normal-sized Viton overglove with 50-percent fabric reinforcement was provided. Controls were established to eliminate undesirable physical defects (such as pits, bubbles, and nonuniform thickness) that had been present in previous overgloves. In addition, the wrist joint between the overglove and the oversleeve was redesigned. The redesign consisted of providing a quick-disconnect attachment so that damaged overgloves could be replaced easily during lunar-sample processing (figs. 6 and 16).

Modification of the pressure-glove assembly consisted of providing more freedom in the thumb area by increasing the distance between the metal retainer and the woven nylon thumb. This change not only provided greater flexibility but reduced the possibility of wear on the thumb caused by contact with the metal retainer during sample processing.

The bulk (fines) ALSRC was transferred into the F-201 vacuum processing chamber on November 26, 1969, and sample processing began. On November 27, the right-hand pressure glove failed. This failure resulted in a pressure rise in the F-201 vacuum glove chamber to at least  $1729 \text{ N/m}^2$  (13 torr). Seventy percent of the lunar rocks in the ALSRC were exposed to this pressure; however, the remainder of the rocks were sealed in a vacuum environment. This set of pressure arm and glove assemblies was changed without heat sterilization based on the argument that, because the overgloves had remained intact, the interstitial space between the pressure-glove assembly and the overglove assembly was not contaminated with lunar material. Investigation revealed failure of the metal pivot point between the pressure-glove metal shell and the adduction/abduction wrist ring (fig. 14). This pivot point was designed to relieve pressure on the nylon fabric in the thumb and finger; with the pivot-point separation, atmospheric pressure ( $103.4 \text{ kN/m}^2$  (15 psia)) was exerted fully on the nylon fabric. This pressure resulted in separation of the fabric from the metal shell of the glove and implosion of the chamber.

On December 4, operations personnel noted that some splitting of the overgloves was occurring between the fingers. The decision was made to replace the overgloves at vacuum and to inspect the pressure gloves at the same time. Inspection of the pressure gloves in the  $0.133\text{-mN/m}^2$  ( $10^{-6}$  torr) environment revealed that the pivot point on the left pressure glove was failing.

Sample processing was halted, and plans and procedures to change out the pressure gloves were initiated. As a result of removing the overgloves, the interstitial area was lunar contaminated, and the process of simply backfilling the chamber and removing the gloves was not possible. The following steps were taken to change the pressure gloves.

1. All lunar material in the F-201 vacuum glove chamber was transferred to the F-207 sample-storage carousel and isolated.
2. The F-201 vacuum glove chamber was backfilled to slightly less than atmospheric pressure to prevent lunar contamination of the ambient environment.
3. A "glove-change chamber" was fabricated and sealed to the chamber glove ports. This glove-change chamber contained a spare pressure arm and glove assembly in a protective bag and the necessary tools to accomplish the pressure-glove changeout.
4. Using neoprene arms and gloves in the collapsible glove-change chamber, an operator interchanged the defective arm and glove assembly and the new arm and glove assembly. Before inserting the new arm and glove assembly into the glove-change chamber, the opening in the new assembly, through which the operator inserted his arm, had been covered to prevent lunar contamination and, therefore, sterilization damage to the new arm and glove assembly.
5. The defective arm and glove assembly then was inserted into the protective sealed bag and the interior of the glove-change chamber sterilized with peracetic acid.

6. The glove-change chamber was removed from the glove-port area of the F-201 processing chamber. The defective arm and glove assembly was left in the sealed bag until quarantine release.

After the Apollo 12 sample processing, rigorous quality-acceptance tests were incorporated to identify defective arm and glove assemblies before the assemblies were used in processing lunar samples. This testing included leak testing of both overarm and glove assemblies and pressure arm and glove assemblies. Fatigue tests were performed in a one-arm-and-glove chamber (F-401) to qualify the arm and glove assemblies for use in the F-201 processing chamber. An operating limit of 150 hours was established for each arm and glove assembly. The assembly was inspected, requalified, and, if necessary, refurbished.

Actions taken to correct the specific problems identified during the Apollo 12 sample processing were to fabricate a 100-percent-reinforced overglove with emphasis on the areas between the fingers and to redesign the wrist pivot point by incorporating more durable metal (301 half-hard stainless steel). The new arm and glove assemblies were satisfactory, and no failures occurred during 2 months of operation in the F-201 and F-401 glove chambers.

### Adaptability of Tools and Containers to Operators, Gloves, and Vacuum Environment

Tool design and modification continued throughout the Apollo lunar-sample processing in the F-201 vacuum glove chamber as scientific requirements were added or deleted and problem areas were identified. However, all tools and containers (figs. 9, 10, and 17 to 27) had to meet basic requirements to ensure proper operations in the chamber.

The operator had to handle the tools with the vacuum gloves. Even with the optimum glove design, working in the vacuum gloves was difficult compared to normal handling in atmospheric-type gloves. The arm severely restricted the working volume; therefore, tools were developed to compensate for this deficiency. Using the pressure arm and glove assembly with the  $103.4\text{-kN/m}^2$  (15 psia) pressure differential across it required much effort by the glove operator (figs. 6 and 13 to 16). Because there was a definite limit on the weight an operator could handle in the F-201 vacuum glove chamber, lifting jacks (fig. 17) were developed.

The average time that an operator could work efficiently in the gloves was approximately 15 minutes, although this time varied with individual operators and tasks. One individual was able to work for 1 hour, whereas others could work only 10 minutes. However, the policy was to change operators approximately every 15 minutes. A task was particularly tiresome for the glove operator if the task required the operator to work with his elbows elevated above the glove wrists; this position would occur if a container or tool fixture was very high or very near the chamber breastplate (or both). An example of this type of task was the sealing of the large 3.3-liter bolt-type containers (fig. 9) used for storing lunar samples. If the container or tool fixture was too far away, efforts by the glove operator to work at the limit of his reach put excessive strain on the glove and increased the possibility of glove failure. Hence, containers and tool fixtures had to be designed or modified to function within these constraints. The fixture for holding containers in place during sealing operations is illustrated in figure 20.

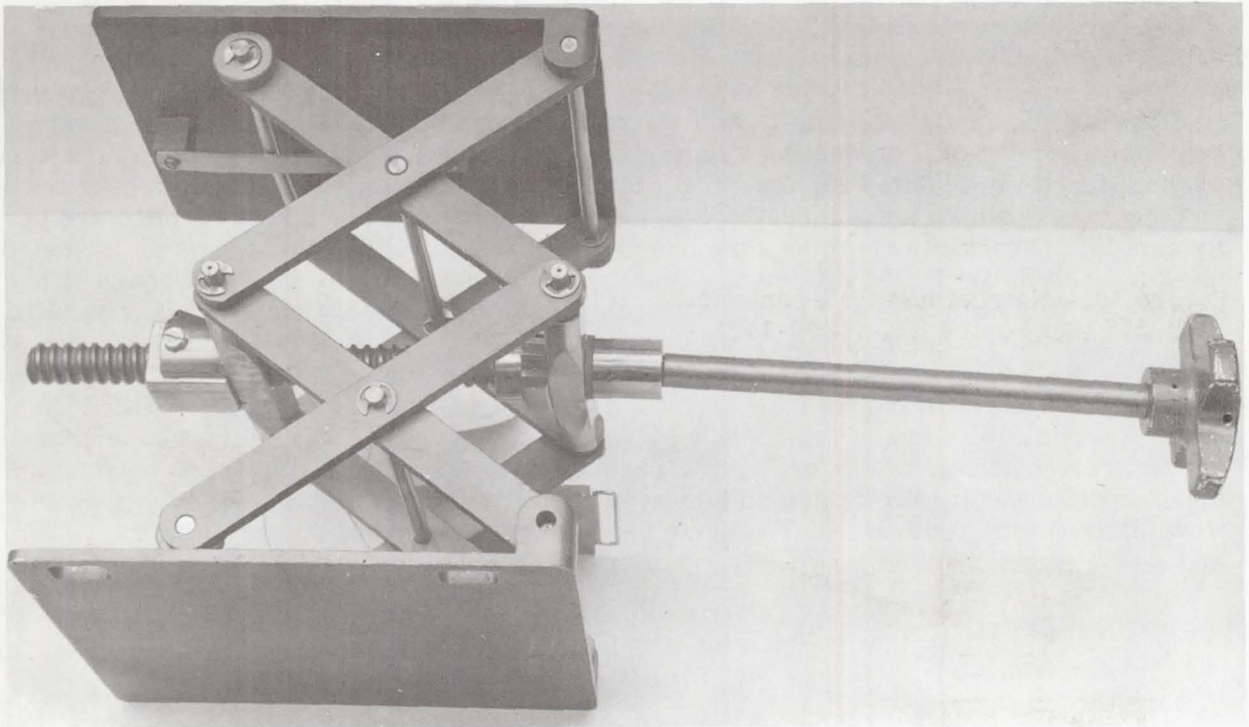

Figure 17.- ALSRC jack F-201-139.

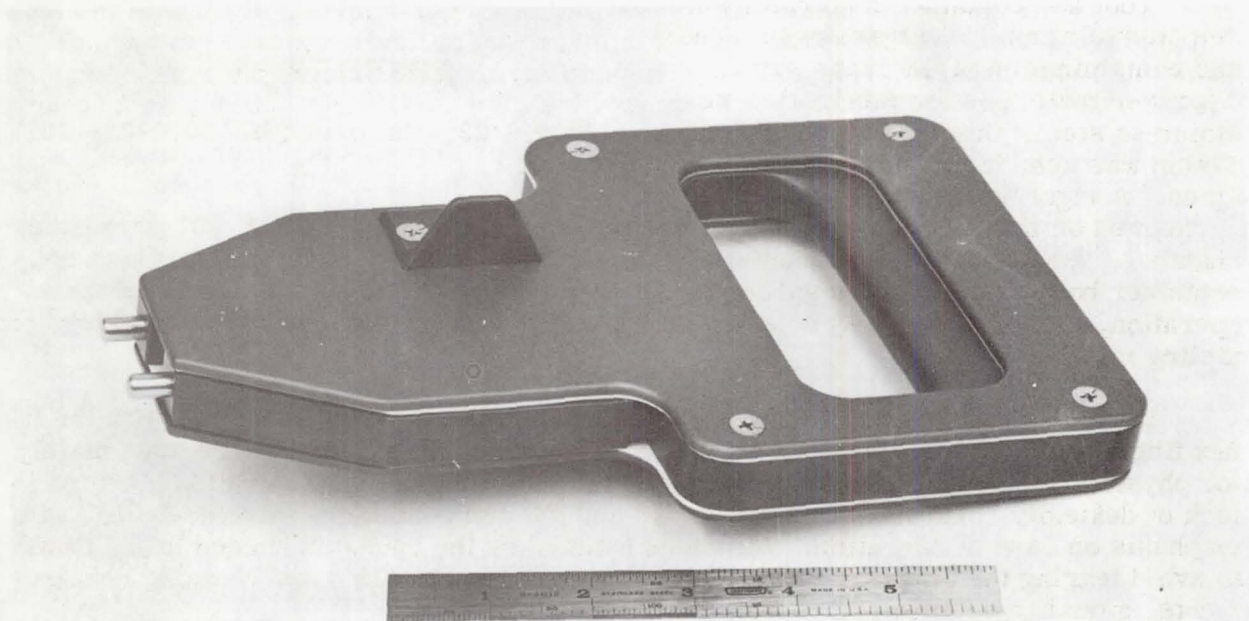

Figure 18.- ALSRC opening pliers (SEZ 36104697-301).

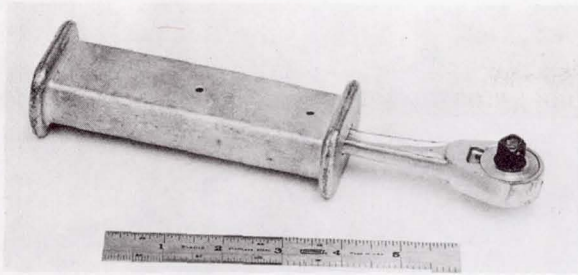

Figure 19.- Ratchet and 0.95-centimeter (0.375 inch) drive (SK 67606-110).

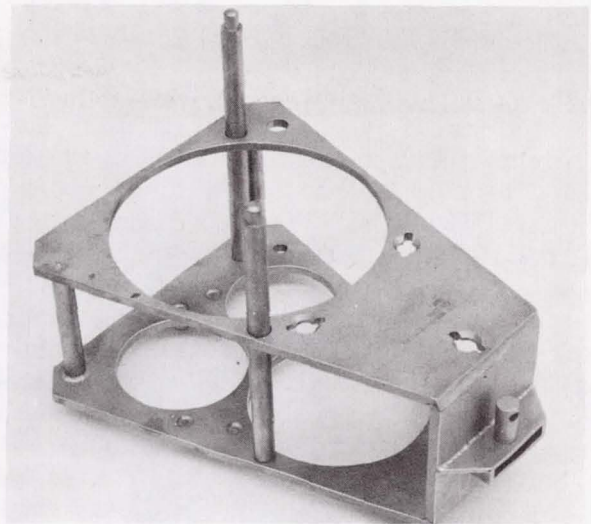

Figure 20.- Canholder assembly (SDZ 36106027-301).

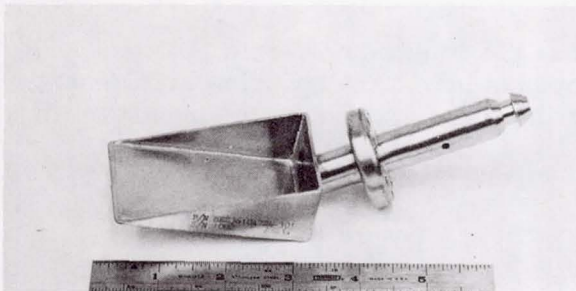

Figure 21.- Five-centimeter (2 inch) scoop (SEZ 36104724-301).

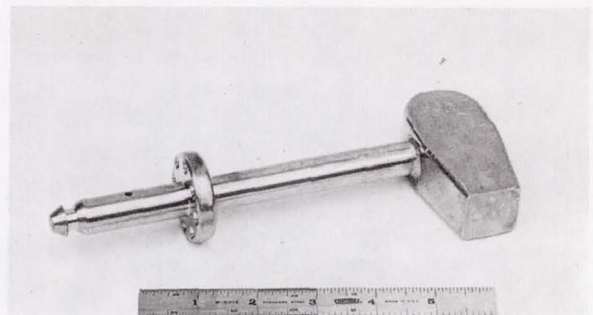

Figure 22.- Hammer (SEZ 36104728-301).

Tool and container materials were selected to minimize outgassing in vacuum and contamination of the lunar sample. Approved materials for fabrication were stainless steel, aluminum, and Teflon. Teflon was used to provide bearing surfaces. A rigorous cleaning procedure was performed on the tools and containers before their insertion into the F-201 processing chamber. Problems were encountered with movable, clean metal surfaces (such as container bolts) and tool dies galling in the vacuum environment. To ensure proper operation, molydisulfide was selected as the only lubricant acceptable for movable, contacting metal surfaces.

Intricate tasks and the lifting of tools and containers were performed with the index finger and thumb of the glove assembly. The remaining fingers were used mainly for physical supporting functions. Because the vacuum glove configuration resulted in lack of dexterity, oversized tools (figs. 18 and 24) and containers were designed, with emphasis on ease of operation. All edges handled by the operator needed broad radii to avoid tearing the gloves. To control these design constraints and cleaning requirements, a quality-assurance program was incorporated.

The two basic types of containers used for storage of lunar samples are shown in figures 9 and 10. The bolt-type containers (fig. 9) were the primary containers for storage in the vacuum system and for sample transfer to other laboratories. The "single action" containers (fig. 10) were designed for quick storage of lunar samples if deterioration of the vacuum environment occurred (high leakage rates, etc.). Once sealed in a vacuum environment, the single-action containers may be opened only in a vacuum environment. By contrast, the bolt-top container bolt screws are an integral part of the lid so that while the bolts are backed out of the container, the lid is lifted. Hence, the vacuum-sealed containers may be opened in an atmospheric environment because the bolts act as jacking screws against the force created by the pressure differential between the container vacuum interior and atmospheric exterior.



Figure 23.- T-handle (SEZ 36106104-301).

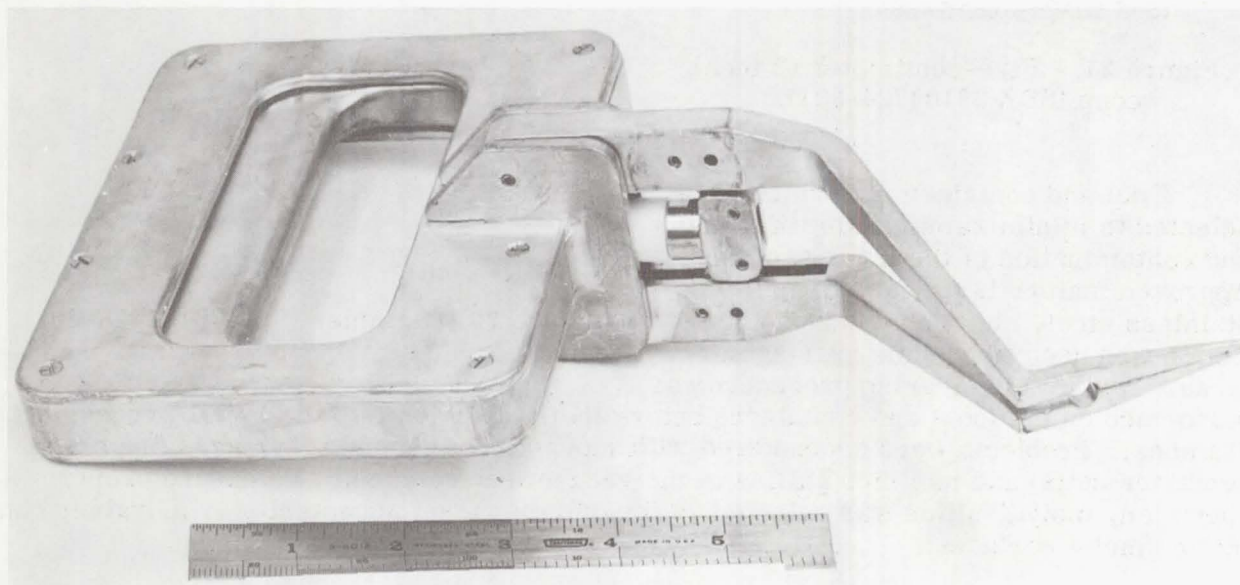

Figure 24.- Tweezers (SEZ 36104416-301).

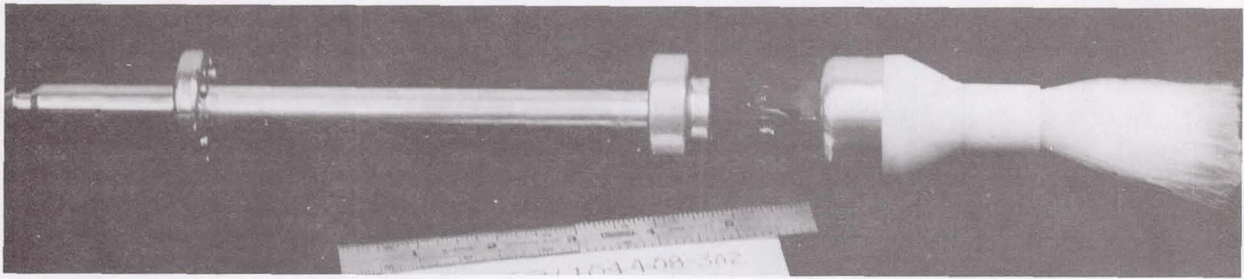

Figure 25.- Floor brush (SEZ 36104408-302).



Figure 26.- Universal handle (SEZ 36104404-301).

To reduce storage volume for tools in the vacuum complex, several types of containers and tools might use a common fixture or item. The container holder (fig. 20) could be adapted to hold all bolt-type container sizes by simply reversing the top and bottom and removing or inserting pins in the fixture. Several common types of tools (figs. 21, 22, and 25) used a common oversized "universal" handle (fig. 26). An earlier version of the universal handle with a tool attached is shown in figure 19. A few tools such as the T-handle (fig. 23) were similar to conventionally designed tools. These tools enabled the glove operator to perform the same tasks in a high-vacuum environment that an unencumbered technician might perform with common tools in an ambient environment.

### Mechanisms of Transfer Between Associated Vacuum Chambers

The most unnecessary, complicated system in the vacuum complex is the transfer system. As stated earlier, the original vacuum complex was designed and fabricated to handle the transfer of samples and tools into two identical sample-processing chambers. Only one sample chamber (the F-201 vacuum glove chamber) was funded and built. However, the transfer system and the connecting chambers in the original design

were built. An unnecessary transfer chamber (F-123) was the result. This chamber contained (for the original design) a rotary track to direct the incoming item, in either of two 90° directions, to the selected processing chamber. With only one processing chamber, this design complicated, lengthened, and reduced the reliability of the transfer process.

To transfer items to and from the F-123 chamber, the rotary track had to be positioned carefully to receive the item or the transfer dolly would roll into the chamber. Transfers among chambers were performed by rolling the transfer dolly and basket along an inverted T-rail, propelled by an extensor system. The extensor is attached to a Teflon rack, which, in turn, is driven by a handwheel-operated vacuum-sealed gear drum. An extensor pin and tab on the dolly engage a cam mechanism on the rail that can latch the dolly to or unlatch the dolly from the transfer rail. The external handwheel controls of the transfer system are shown in figure 1.

This cam mechanism is positioned in the centralized or neutral portion of the transfer chamber (F-202, F-302, and F-203). The purpose of the mechanism is to lock the dolly into a position so that the valves on either end of the transfer chamber may be opened or closed without hitting the dolly. The valve closure provides chamber isolation when items are being transferred between chambers at different pressure levels. Also, the extensor system has to be placed in its neutral position to prevent damage during valve closure. To continue transfer, the extensor system is moved to its unlatch position, which frees the dolly, and the dolly and basket are moved into the terminating chamber. The extensor then is returned to its neutral position. Two types of container dollies are illustrated in figures 11 and 12. The dolly and basket in figure 11 are used for storing special small sample containers. Shown in the photograph are the dolly ball-bearing wheels that ride on the inverted T-monorail, the two dolly tabs, and the dolly pin that activates the latch/unlatch mechanism. Figure 12 is an example of one of the bolt-top container storage dollies. One of the dolly tabs is shown at the top center of the dolly.

The tolerances of the extensor position indicators in the handwheel are very loose in comparison to the critical tolerances of the latch and unlatch cam mechanism. Hence, an operator had to be very careful during the transfer procedure. A mistake usually jammed the transfer system. Jams in the system occurred if rail alinement among chambers was incorrect because of misalinement by the operator, heavy loads changing

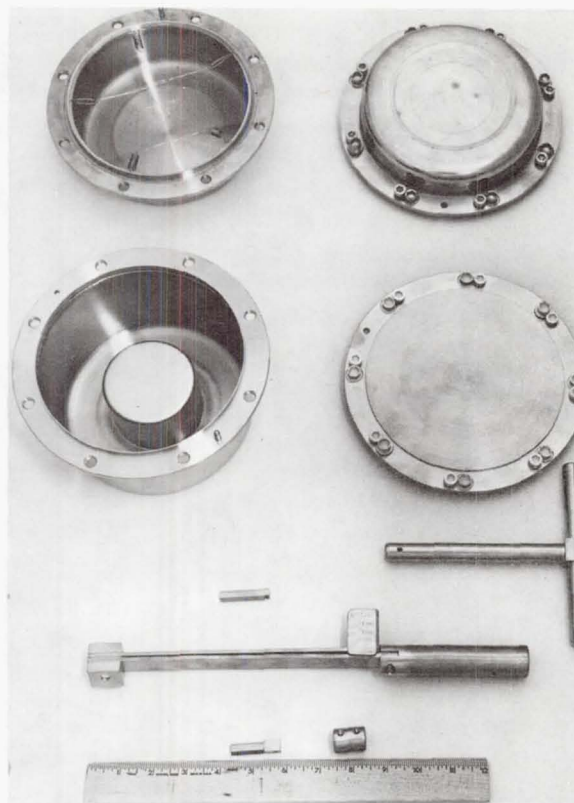

Figure 27.- Radiation counting sample containers and tools.



the alinement, or changes as a result of the rotary rail action in the F-123 transfer chamber and the storage-carousel chambers. Also, damage to the extensor pin, the dolly tab, or the cam resulted in a jam. The critical and unnecessary tolerances of the cam mechanism are illustrated by the following example.

In retrieving a sample dolly from the storage carousel, a glove operator accidentally ripped the left overglove on the dolly extensor tab. To avoid possible future damage to overgloves, the rectangular tab on each dolly was rounded off 0.079 centimeter (0.031 inch) at the upper corners (figs. 11 and 12). After this configuration change, the dolly would jam in the transfer cam mechanism. To correct this jamming of the transfer system, the rounded-off material had to be reinstated on all dollies.

Because the design, fabrication, and installation of a simpler transfer system was not feasible in terms of the high-vacuum complex downtime and the time interval between missions, a workaround solution was formulated. Detailed procedures were implemented to prevent operator error. Simultaneous operations were halted during transfer procedures to avoid communication problems. A retrieval rod was designed and fabricated to allow the glove operator to retrieve the dolly if a jam did occur. The rod was variable in length (i. e., rod lengths could be added or subtracted) to facilitate access to various transfer system areas.

The preceding actions were compromises to avoid installing a new system. The compromises avoided degradation to the vacuum complex as the result of extended exposure to atmospheric gases and maintenance tasks. The vacuum-environment quality gained after the Apollo 11 sample processing would not have been recoverable if a new transfer system had been installed between subsequent missions.

## Sample Processing

The basic sample-processing procedure in the vacuum system was as follows.

1. Receive the ALSRC.
2. Measure the background gases in the sealed ALSRC with a residual-gas analyzer.
3. Open the ALSRC and inventory the contents.
4. Transfer or store the special containers.
5. Sieve lunar material to separate rocks and lunar soil (fines).
6. Prepare the Radiation Counting Laboratory (RCL) sample and bioprime samples.
7. Weigh and photograph individual rock samples.
8. Perform microscopic examination. (Scientific observer performs this examination.)

9. Split selected rocks and transfer the chips to the physical science laboratories (the Physical-Chemical Test Laboratory, the Gas Analysis Laboratory, the Thin Section Laboratory, and the Mineral Separation Laboratory).

10. Perform postsplit weighing and photography.

11. Conduct lunar soil (fines) processing and loading of special principal investigator containers.

Three samples were time-critical in processing out of the high-vacuum complex: the RCL sample, the bioprime sample, and the "biopool" sample. The RCL sample had to be transferred to the RCL as quickly as possible to identify the presence of short-half-life isotopes. The concentrations of the short-lived cosmic-ray-produced nuclides of elements such as vanadium,  $^{48}\text{V}$  (half life = 16.2 days), and manganese,  $^{52}\text{Mn}$  (half life = 5.7 days), are detected by nondestructive gamma-ray spectroscopy. The bioprime and biopool samples were used by the biological laboratory to establish quarantine-release criteria. The bioprime sample had to be transferred from the vacuum complex within 3 to 5 days. This sample was chosen from the lunar soil (fines) material. The biopool sample, transferred from the system after 15 to 17 days, was composed of chips from the lunar rocks. During Apollo 11 sample processing, chips from all the returned rocks were required. During Apollo 12 sample processing, only chips from major types of rocks were required.

The RCL sample procedure changed most radically before the Apollo 11 and 12 sample processing. Preparation of the RCL sample was complicated because it was the only sample to be transferred to a laboratory outside the quarantine barrier and because knowledge of the orientation of the sample in the container was necessary for accurate results in performance of the experiment. Because of the aforementioned requirements, the following procedures were incorporated.

The originally conceived RCL procedures are outlined as follows.

1. The sample is scan photographed in the F-201 vacuum glove chamber. Scan photography consists of a series of photographs taken as a plane of light is projected around the perimeter of the rock. This plane of light transverses the height of the rock as the platform is moved in 0.318-centimeter (0.125 inch) intervals. These photographs define the sample contours so that a rough model of the rock can be fabricated. Concave surfaces that are not defined adequately by the light projection are defined by the modeler from record (positive) photography.

2. A split mold with indium-tinned edges is fabricated from the model as an inner container for the sample.

3. The inner container is put into a large transfer container.

4. The transfer container is evacuated, heat sterilized, and transferred into the F-201 glove chamber.

5. The inner container is removed from the transfer fixture, and the transfer fixture is transferred from the chamber.

6. The lunar sample is inserted in the inner container mold, and the container mold is inserted in an outer container.

7. The outer container is positioned in a heating fixture that melts the indium on the outer edge of the inner container. This melting produces a leaktight seal between the two halves of the outer container.

8. The container is removed from the sealing fixture and inserted in a special vessel.

9. The special vessel is sealed by the glove operator and pressurized for a specified time with gaseous nitrogen at pressures between the chamber operating pressure and  $101.3 \text{ kN/m}^2$  (1 atmosphere).

10. The container is removed from the special vessel after reevacuation of the vessel and inserted in a leak-check vessel.

11. The atmosphere in the sealed leak-check vessel is monitored by a residual-gas analyzer to determine whether nitrogen is leaking from the container. This monitoring indicates whether the nitrogen has penetrated the container through a faulty seal during the nitrogen-pressurization step.

These procedures were complicated, lengthy, and dangerous. The excessive weight of the transfer fixture caused misalignment of the vacuum system transfer rail. The operator had to spend a minimum of 2 hours in opening the container to retrieve the inner container from the transfer fixture. The weight of the fixture prevented the glove operator from reassembling and transferring the fixture from the chamber. No successful seals were ever made with the indium-melting technique. Because the vacuum gloves prevented any transfer of heat to the glove operator, a high probability of severe damage to the gloves existed. Also, if an operational error or pressurized vessel failure occurred during the nitrogen-pressurization sequence, damage from exposing the glove chamber to high-vacuum pressures was probable.

By the time of the Apollo 11 sample processing, a simple container sealed by using the same technique used for other sample containers (O-ring type) was designed and fabricated. The container had a spring-loaded stainless-steel net that held the sample in a fixed location in the container. The tools and container components associated with this RCL sample container are shown in figure 27. Extensive tests before container use established successful sealing techniques. Just before sealing, photographs of the sample in the container were taken to record orientation of the sample. The scan-photography procedure was retained to help in fabricating models of the sample. These models were useful in standardization tests of the radiation counting experiment. The sample container was sealed in three Teflon bags as an additional precaution in transferring the container through the quarantine barrier.

The Apollo 11 scientific requirements necessitated that all rock samples be split and that the daughters (split portions of the sample) be distributed to other analytical laboratories. A special tool was developed by the NASA Jet Propulsion Laboratory (JPL) to split the lunar rocks and to cold-weld seal the lunar-rock chips into a special aluminum container. The JPL rock splitter and sealer developed for the Apollo 11 sample processing was a third version. The excessive weight and complexity of the first two rock splitters and sealers made handling by the glove operator difficult. The third rock splitter and sealer used a ball-screw design in developing 142 kilonewtons (16 tons) of force. To convert from the rock-splitter mode to the container-sealing mode was a tedious procedure in which the splitter jaws were replaced with dies for sealing the 3.81-centimeter (1.5 inch) diameter aluminum containers. These aluminum containers were used to transfer small lunar chips and lunar soil (fines) to other laboratories and principal investigators.

Difficulties were experienced in handling these aluminum containers. The containers were damaged easily, and the sealing surfaces had to be free of contamination. Lunar dust or oxidation (formed before container installation in the chamber) on the sealing surfaces prevented the cold-welding process. Glove operators developed the technique of brushing the container surfaces with a stainless-steel wire brush just before sealing.

Use of the splitting capability of the JPL rock splitter and sealer during the Apollo 11 sample processing was minimal. Most rock samples could be split with a hammer and chisel. The angular shape of many lunar-rock samples and the short jaws of the rock splitter were not compatible in providing well-controlled splitting.

For the Apollo 12 sample processing, a manual rock splitter was developed that is similar to a miniature guillotine. The glove operator applies the splitting force with a hammer. Controlled splitting was improved greatly. Not all lunar samples were split during the Apollo 12 sample processing. The decision to split a specimen was based on the requirement to sample different types of lunar rocks instead of each individual rock (the Apollo 11 requirement). The elimination of much postsplit photography and weighing greatly accelerated mission processing. Retaining the JPL rock splitter and sealer in its container-sealing mode (as during the Apollo 11 sample processing) eliminated much effort by the glove operator.

Maintaining cleanliness of the F-201 vacuum glove chamber during both Apollo 11 and Apollo 12 sample processing was a problem. The tool and container clutter impeded efforts by the glove operator to perform this function. For the Apollo 12 sample processing, the clutter was reduced greatly as tool and container requirements were better defined. In addition, only the most proficient of the Apollo 11 glove operators were retained. These glove operators became efficient at reducing lunar dust collected on the chamber floor, although the operators were impeded by the vacuum gloves in recovering the dust. Aluminum foil was found to be very useful in reducing contamination of the chamber floor; the foil was spread beneath the working area to catch the dust. This foil could then be folded by the glove operator to hold the dust.

## Development of an Effective Operational Team

As with the vacuum environment, the quality of team effort on the vacuum sample improved with experience. Before the Apollo 11 sample processing, personnel spent most of the time, including simulations, in solving hardware problems. As a result, training of personnel in sample handling and procedural protocol was minimal.

Operational personnel worked overtime in correcting design and fabrication deficiencies of the vacuum processing complex. In April 1969, a quality-assurance program was initiated for the F-201 vacuum processing complex to avoid these types of problems in the future.

Procedures were in continuous revision until a few weeks before the Apollo 11 lift-off as scientific requirements for handling the lunar material changed. This revision was partly an attempt to cover all contingencies in handling the unknown quality and quantity of the lunar material.

To provide continuous direct support for the F-201 vacuum complex for the Apollo 11 sample processing, 15 people were required. This number included glove-chamber personnel, atmospheric decontamination personnel, sample-transfer personnel, communication- and control-console operators, and contractor and NASA supervisors.

Even with the planned contingencies, most decisions concerning sample handling were made by management personnel outside the quarantine barrier through a communication link. To evaluate the situation behind the barrier, coordinate the decisionmaking process, and then transmit the decision to the operational personnel was a slow procedure.

The transfer of items (samples and tools) through the atmospheric decontamination cabinets was slow as a result of the drying process in the cabinets. The peracetic-acid-sterilized items had to be flushed with water and dried before insertion in the F-123 transfer chamber. Transfer through the vacuum transfer chambers was slow because of the time required for transfer chamber pumpdown. This pumpdown period was required to achieve an optimum vacuum environment. In addition, transfers were delayed because of the signature approval required to transfer each individual item from the vacuum sample-processing complex. Approval forms had to be either transmitted or reproduced across the barrier to facilitate signature approval by the quarantine-control officer.

Because of the pressure to expedite the unique Apollo 11 lunar samples and to compensate for the delays mentioned previously, simultaneous transfer and F-201 glove chamber procedures were conducted. In addition, the combination of procedures resulted in the processing of several samples simultaneously in the F-201 glove chamber. For example, the glove operator would be chipping or canning a sample while one or more samples were being weighed or photographed. Consequently, a number of samples were exposed to vacuum pressures of approximately  $1995 \text{ N/m}^2$  (15 torr) (as contrasted to normal operating pressure near  $0.133 \text{ mN/m}^2$  ( $10^{-6}$  torr)) in the F-201 vacuum glove chamber when the vacuum glove failed.

By the time of the Apollo 12 sample processing, the lunar samples had fewer unknown qualities; and the speed of processing, except that of biological protocol and short-life radiation counting samples, was not as critical. In addition, several hardware and procedural changes were made to expedite sample processing.

Requirements and procedures were better defined. Most decisions concerning processing of the lunar material were made by the vacuum-laboratory test director behind the quarantine barrier. Because the director was familiar with the situation, any problem could be resolved quickly. A heat sterilizer was added to the vacuum complex to avoid excessive delay of inbound tools and containers through the peracetic-acid-sterilization system. Also, this addition reduced clutter in the glove chamber because tools and containers could be transferred into the chamber without exposure to the peracetic acid. Hence, the loading of all potentially required tools and containers before sample receipt was not necessary. The procedures for transferring outbound sample containers through the peracetic-acid-sterilization cabinets were simplified and standardized to avoid time spent in obtaining signature approval.

Simultaneous operations were eliminated to reduce communication difficulties and to avoid simultaneous exposure of an excessive number of samples in the glove chamber. Unfortunately, initial lunar-rock inventory was still in process when the vacuum glove failed. Consequently, a number of rocks were exposed to high pressure. All the lunar soil (fines) and a third of the rock samples were protected in the F-207 storage carousel.

Vacuum transfer operations did not have to be performed simultaneously with glove operations. The pumpdown of the F-123 transfer chamber had been reduced from the 4 to 5 hours required at the beginning of the Apollo 11 sample processing to between 10 and 15 minutes at the end of the Apollo 12 sample processing. Hence, glove operations could be halted long enough to complete a transfer.

Implementation of these procedures effectively reduced the number of personnel required for continuous direct support of the F-201 vacuum complex to half the number required for the Apollo 11 sample processing (a reduction from 15 to 7 persons).

Several types of problems were identified during the Apollo 11 and 12 sample processing. The major types were as follows.

1. Monitoring and recording vacuum pressure automatically from atmospheric pressure to  $1.33 \mu\text{N}/\text{m}^2 (10^{-8} \text{ torr})$
2. Monitoring small changes in the vacuum glove interstitial pressure to detect changes in the physical condition of the vacuum gloves
3. Monitoring more effectively the entire vacuum complex and increasing the response time of the console controller to changes in the vacuum-environment status
4. Providing more effective heater control on the chambers and the complex network of the vacuum headers

These problems were solved with in-house design and procurement of necessary instrumentation. Support was received from MSC heat-transfer personnel, who used computer simulation methods to establish vacuum-header heat loads.

The vacuum-complex control console was redesigned and rebuilt after the Apollo 12 sample processing. The original control and status panel was 3.35 meters (11 feet) long, which limited the ability of the console operator to monitor and react to sudden changes in the vacuum status. The control and monitor panels were reduced to one 96.52-centimeter (38 inch) long panel and one 48.26-centimeter (19 inch) long panel. The smaller panel was restricted to emergency use in case of glove failure. The valve controls and verification indicator were superimposed on a line diagram of the vacuum complex to allow the operator to establish system status quickly. The status of all pumps, including ion pumps, was established on the panel. An interlock system was incorporated into the control console to prevent closure of a valve on an extensor.

Instrumentation that provided a complete recorded history of vacuum pressure, from the low-operating-vacuum pressures to atmospheric pressure, was incorporated into the console. This instrumentation eliminated the gap in vacuum-pressure histories that resulted during glove failures. With this upgraded instrumentation, the control-console operator could establish system status at any pressure or at any time. The instrumentation on the vacuum glove interstitial volume enabled better detection of deterioration in vacuum glove status before a glove failure occurred. Because material fatigue was the cause of a number of arm/glove failures, the steady differential rise in interstitial pressure was an indicator of the pressure arm/glove deterioration. If the deterioration could be detected in time, the arm/glove assembly could be replaced before a catastrophic failure occurred. This instrumentation provided better than 10 times the resolution of the earlier gage in monitoring the interstitial vacuum pressure.

## POSTMISSION PROCESSING

The F-201 vacuum sample-processing complex was not used for Apollo missions after the Apollo 12 mission. However, a month of operating time was expended during the summer and fall of 1970 in processing Apollo 11 and 12 samples for the curator. These samples had been placed in a vacuum environment in a storage carousel following completion of the missions. Chipping operations were performed on lunar rocks and lunar soil (fines) loaded into several special containers. Operations were conducted in the  $13.3\text{-}\mu\text{N/m}^2$  ( $10^{-7}$  torr) vacuum range.

Sample operations proceeded very smoothly and under the cleanest conditions experienced in the F-201 vacuum glove chamber. The chamber did not require recleaning between processing of the Apollo 11 samples and the Apollo 12 samples. This level of cleanliness was achieved by care on the part of the glove operator; extensive use of aluminum foil to protect the chamber floor and containers from lunar dust; and improved, controlled sample chipping.

The controlled sample chipping was achieved by taking photographs of the pre-chipped sample and using these photographs to instruct the glove operator on the chipping procedure to be followed. In addition, heavy aluminum foil was shaped to provide a barrier around the chipping area to catch flying chips.

Investigation of the vacuum gloves after the processing revealed no physical damage. Moreover, no arm and glove assembly failures occurred.

With only five basic operating personnel, the F-201 vacuum sample-processing complex began to reach its full potential during this postmission processing.

## CONCLUDING REMARKS

After the vacuum complex had begun to reach its full potential, the complex did not support any subsequent Apollo missions. No samples were returned from the Apollo 13 mission, and scientific requirements for vacuum sample processing were deleted before the Apollo 14 mission.

Perhaps the most imposing constraints on the vacuum complex in reaching its full potential to support the Apollo 11 and 12 missions were time and lack of flexibility. Too much basic development work was still being accomplished on the complex 6 months before the Apollo 11 sample processing; identification of operational problems and refinement of operational tasks should have been the prime objectives during this period. Of course, a portion of the basic development work was a result of the continuing effort to meet both scientific and quarantine requirements in handling the unknown characteristics of lunar material. Requirement conflicts developed, particularly concerning sample packaging and transferring, that had to be resolved. Incorporation of the new requirements resulted in development of new containers and the addition of a heat sterilizer to the complex. Efforts expended on these types of development problems reduced the time devoted to procedural training of the personnel and to purging of the vacuum complex.

The vacuum processing complex was a complicated system because of the necessity to satisfy the quarantine and scientific requirements and to implement contingency actions, which sometimes were contradictory; therefore, compromises were required. The situation was unique; an unknown entity (lunar material) was being returned from the Moon. Nothing was known about the potential effect of Earth atmospheric pressure and gases on the material. The presence or absence of potentially harmful lunar organisms was unknown. To help answer these and other questions, the high-vacuum complex was designed; because speed of processing was important in getting answers quickly, a second glove chamber was part of the original complex design. Although the second glove chamber was eliminated because of funding cuts, the transfer chambers for connecting the existing glove chamber and the second proposed chamber remained in the complex. Therefore, the complexity of having two glove chambers still remained because the transfer system, a complicated vacuum header, and a large control console still remained. The resulting operational and engineering problems were identified and solved.

After the Apollo 11 mission, many of the questions concerning lunar material were answered. It was established that lunar material could be safely handled at atmospheric pressure and its integrity preserved in a dry-nitrogen environment.



After the Apollo 12 mission, the requirement for vacuum lunar samples had diminished and greater ease and speed of lunar-sample processing was shown in the dry-nitrogen cabinets. However, even with the problems discussed previously, the Lunar Receiving Laboratory high-vacuum complex proved to be the best compromise in meeting both quarantine and scientific requirements in handling the initial receipt of the lunar material on Earth.

Lyndon B. Johnson Space Center  
National Aeronautics and Space Administration  
Houston, Texas, April 9, 1976  
914-40-52-01-72