

General Disclaimer

One or more of the Following Statements may affect this Document

- This document has been reproduced from the best copy furnished by the organizational source. It is being released in the interest of making available as much information as possible.
- This document may contain data, which exceeds the sheet parameters. It was furnished in this condition by the organizational source and is the best copy available.
- This document may contain tone-on-tone or color graphs, charts and/or pictures, which have been reproduced in black and white.
- This document is paginated as submitted by the original source.
- Portions of this document are not fully legible due to the historical nature of some of the material. However, it is the best reproduction available from the original submission.

74-10996(8)

A32570

System Optimization
Preliminary Specification

DEVELOPMENT OF A SOLAR-POWERED
RESIDENTIAL AIR CONDITIONER

Contract NAS8-30758
74-10996(8)

(NASA-CR-149975) DEVELOPMENT OF A SOLAR-POWERED RESIDENTIAL AIR CONDITIONER: SYSTEM OPTIMIZATION PRELIMINARY SPECIFICATION (AiResearch Mfg. Co., Los Angeles, Calif.) 134 p HC \$6.00 CSCL 10A G3/44 N76-30660
Unclas 50114

Prepared for

George C. Marshall Space Flight Center
National Aeronautics and Space Administration
Marshall Space Flight Center
Huntsville, Alabama 35812



AIRESEARCH MANUFACTURING COMPANY
OF CALIFORNIA



System Optimization
Preliminary Specification

DEVELOPMENT OF A SOLAR-POWERED RESIDENTIAL AIR CONDITIONER

Contract NAS8-30758

74-10996(8)

November 7, 1975

Prepared by

J. Rousseau
K. C. Hwang

Approved by

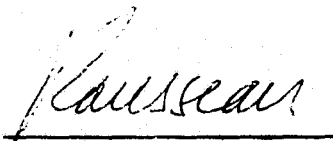

J. Rousseau

Prepared for

George C. Marshall Space Flight Center
National Aeronautics and Space Administration
Marshall Space Flight Center
Huntsville, Alabama 35812



AIRESEARCH MANUFACTURING COMPANY
OF CALIFORNIA

SECTION 1

INTRODUCTION

This report summarizes the results of investigations conducted under Tasks 5 and 6 of Contract NAS8-30758. These tasks were aimed at (1) the optimization of the baseline Rankine-cycle solar-powered air conditioner definitized under Task 4, and (2) the development of a preliminary system specification.

Efforts under Task 5 encompass the following:

- (a) Investigations of the use of recuperators/regenerators to enhance the performance of the baseline system.
- (b) Development of an off-design computer program for system performance prediction over a range of interface parameters including ambient conditions, conditioned space temperature, and heat source water temperature.
- (c) Optimization of the turbocompressor design to cover a broad range of conditions and permit operation at low heat source water temperatures.
- (d) Generation of parametric data describing system performance (COP and capacity) over a range of interface parameters.
- (e) Development and evaluation of candidate system augmentation concepts; selection of the optimum approach.
- (f) Generation of auxiliary power requirement data over a range of operating conditions.
- (g) Development of a complete solar collector-thermal storage-air conditioner computer program.
- (h) Evaluation of the baseline Rankine air conditioner over a five-day period simulating the NASA solar house operation.
- (i) Evaluation of the air conditioner as a heat pump.

Data covering these topics are presented in this report. A listing of the air conditioner off-design performance prediction computer program is given in Appendix A, with a definition of the input and output data. Appendix B contains a listing of the overall solar system simulation program and also includes a listing of the input and output data. Appendix C contains the preliminary system specification.



SECTION 2

SYSTEM PERFORMANCE WITH RECUPERATORS

A number of Rankine system arrangements were investigated to determine what thermodynamic benefits could be achieved through the use of recuperators. The performance of each of the various approaches considered was calculated using the following design point conditions and assumptions.

System capacity: 10.5 kw (3 tons)

Refrigerant: R-11 common refrigerant for the power and refrigeration loops

Evaporator outlet: 280.4 K (45 F) saturated

Condenser outlet: 305.4 K (90 F) saturated

Boiler outlet: 358.2 K (185 F) saturated

Compressor efficiency: 0.736 (same as baseline system)

Turbine efficiency: 0.771 (same as baseline system)

Boiler, evaporator, condenser ΔP : 5 percent of inlet pressure

Recuperator, subcooler/superheater ΔP : 2 percent of inlet pressure on vapor side; on liquid side, ΔP negligible

Recuperator, subcooler/superheater effectiveness: 0.85 max.

The results of these investigations are summarized in Table 2-1, which presents the following information for the baseline system and each of the other six configurations considered:

System schematic

Thermodynamic state points and flow rates

Thermodynamic cycle on P-H diagrams

Compressor and turbine flow and enthalpy rise (ΔH)

Overall system thermal COP

Recommendations



TABLE 2-1

SUMMARY OF RANKINE-POWERED AIR CONDITIONER ARRANGEMENTS
 (T: TEMPERATURE, DEG F; P: PRESSURE, PSIA; H: ENTHALPY, BTU/LB; W: FLOW RATE, LB/HR)

SYSTEM ARRANGEMENT

THERMODYNAMIC CYCLE

MAJOR CHARACTERISTICS/REMARKS

A. BASELINE

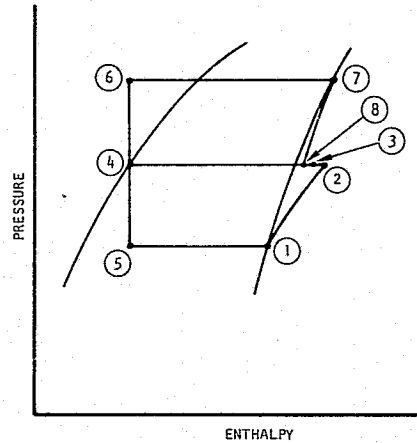
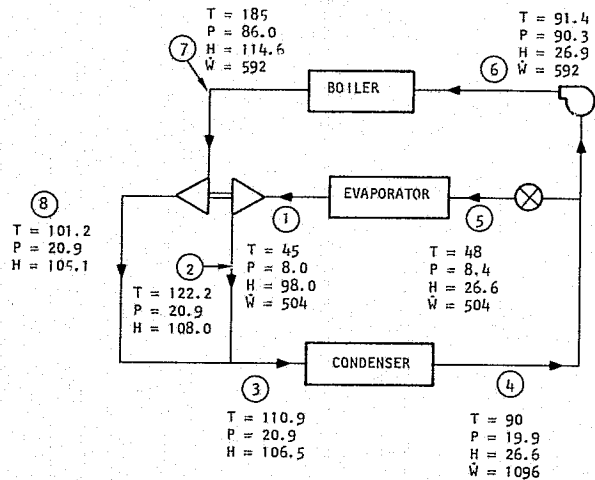

CHARACTERISTICS

	COMPRESSOR	TURBINE
FLOW, LB/HR	504	592
ΔH , BTU/LB	10	9.5
BOILER Q: 51,920 BTU/HR		
THERMAL COP: 0.69		

REMARKS

RECOMMENDED CONCEPT.

B. FULL FLOW RECUPERATOR

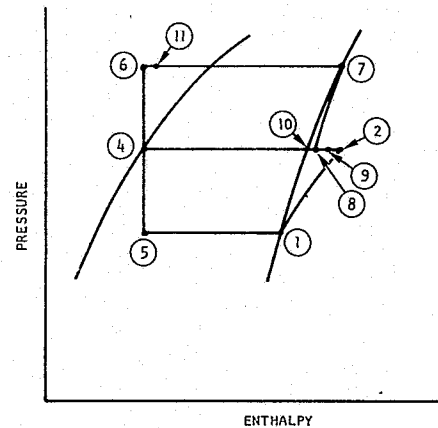
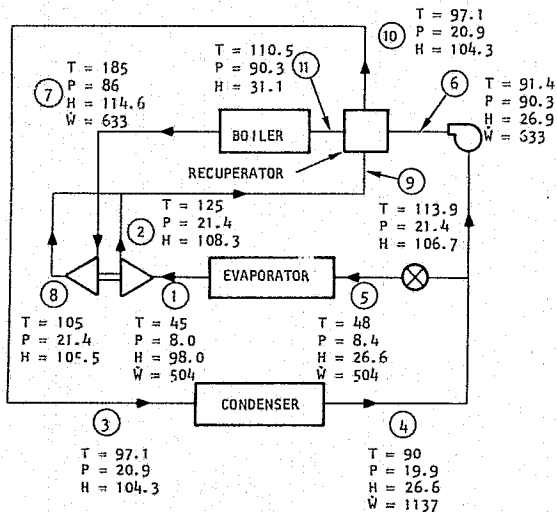

CHARACTERISTICS

	COMPRESSOR	TURBINE
FLOW, LB/HR	504	633
ΔH , BTU/LB	10.3	9.1
BOILER Q: 52,860 BTU/HR		
RECUPERATOR Q: 2660 BTU/HR		
THERMAL COP: 0.68		

REMARKS

LOWER COP DUE TO RECUPERATOR PRESSURE DROP; MORE COMPLEX THAN BASELINE. NOT RECOMMENDED.

C. COMPRESSOR RECUPERATOR



AIRESEARCH MANUFACTURING COMPANY OF CALIFORNIA

FOLDOUT FRAME

C. COMPRESSOR RECUPERATOR

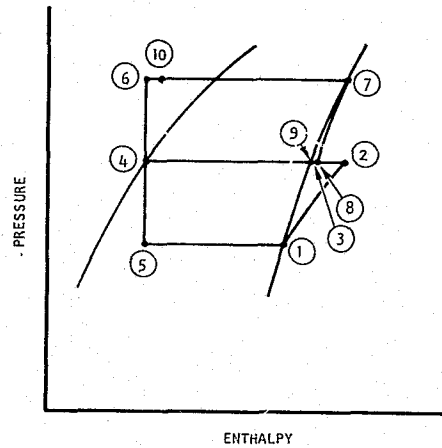
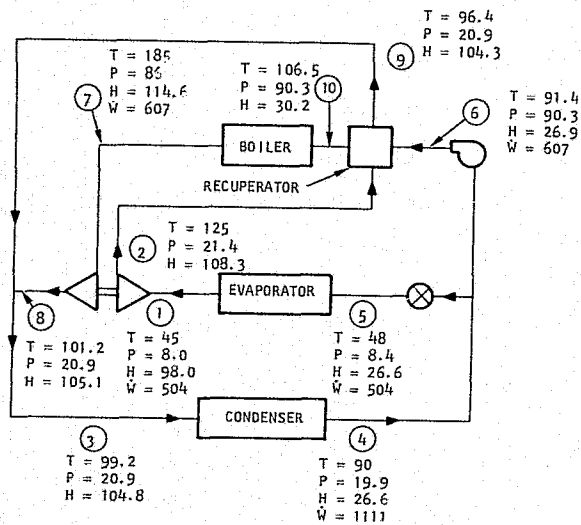

CHARACTERISTICS

	COMPRESSOR	TURBINE
FLOW, LB/HR	504	607
ΔH , BTU/LB	10.3	9.5
BOILER Q: 51,230 BTU/HR		
RECUPERATOR Q: 2000 BTU/HR		
THERMAL COP: 0.70		

REMARKS

SLIGHTLY HIGHER COP DUE TO BOILER LOAD REDUCTION; MORE COMPLEX. NOT RECOMMENDED.

D. SUBCOOLER/SUPERHEATER

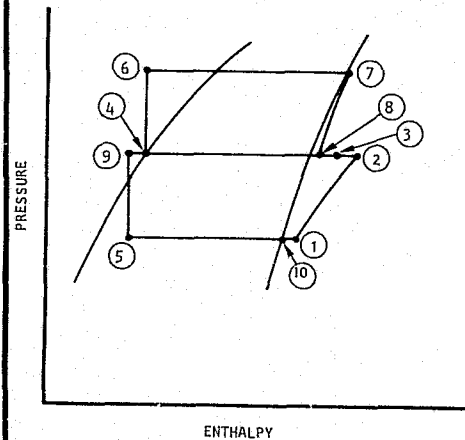
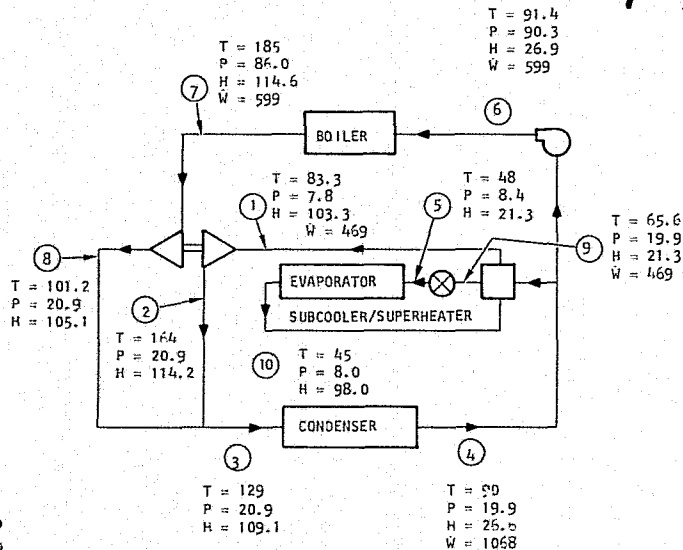

CHARACTERISTICS

	COMPRESSOR	TURBINE
FLOW, LB/HR	469	599
ΔH /BTU/LB	10.9	9.5
BOILER Q: 52,530 BTU/HR		
SUPERHEATER Q: 2490 BTU/HR		
THERMAL COP: 0.69		

REMARKS

NO PERFORMANCE ADVANTAGE FOR ADDED COMPLEXITY. NOT RECOMMENDED.



REPRODUCIBILITY OF THE
ORIGINAL PAPER IS POOR

TABLE 2-1 (Continued)

E. SUBCOOLER/SUPERHEATER-RECUPERATOR

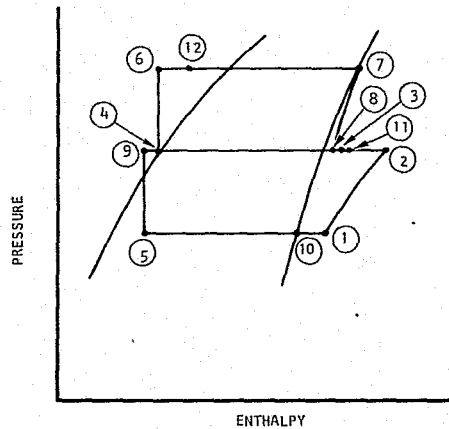
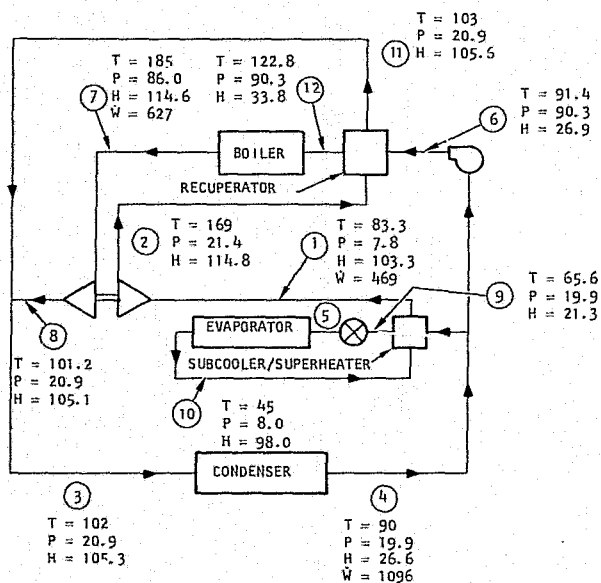

CHARACTERISTICS

	COMPRESSOR	TURBINE
FLOW, LB/HR	469	627
ΔH , BTU/LB	11.4	9.5
BOILER Q: 50,660 BTU/HR		
RECUPERATOR Q: 4330 BTU/HR		
SUPERHEATER Q: 2490 BTU/HR		
THERMAL COP: 0.71		

REMARKS

HIGHER COMPRESSOR HEAT RESULTS
IN MARGINAL COP IMPROVEMENT
WHICH DOES NOT WARRANT ADDITION
OF TWO HEAT EXCHANGERS.
NOT RECOMMENDED.

F. SUBCOOLER/SUPERHEATER-FULL FLOW
RECUPERATOR

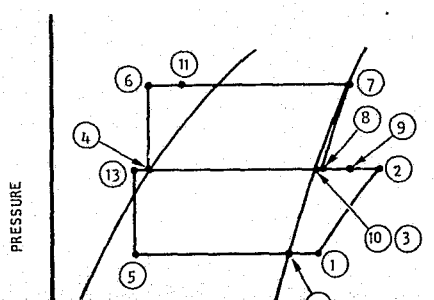
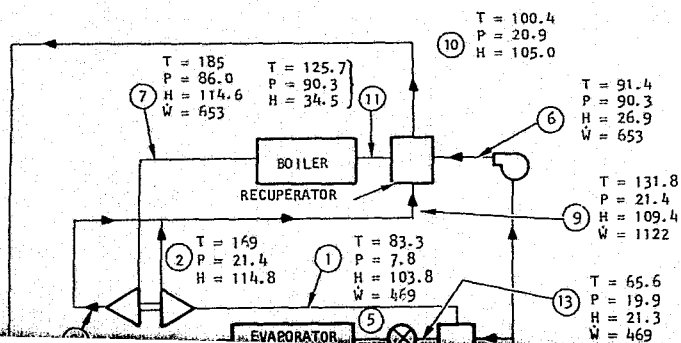

CHARACTERISTICS

	COMPRESSOR	TURBINE
FLOW, LB/HR	469	653
ΔH , BTU/LB	11.5	9.1
BOILER Q: 52,310 BTU/HR		
RECUPERATOR Q: 4960 BTU/HR		
SUPERHEATER Q: 2490 BTU/HR		
THERMAL COP: 0.69		

FOLOUW

RECUPERATOR

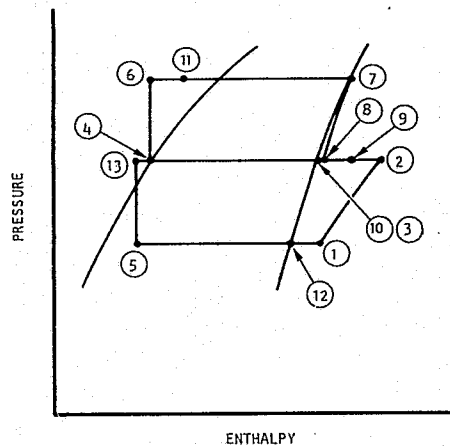
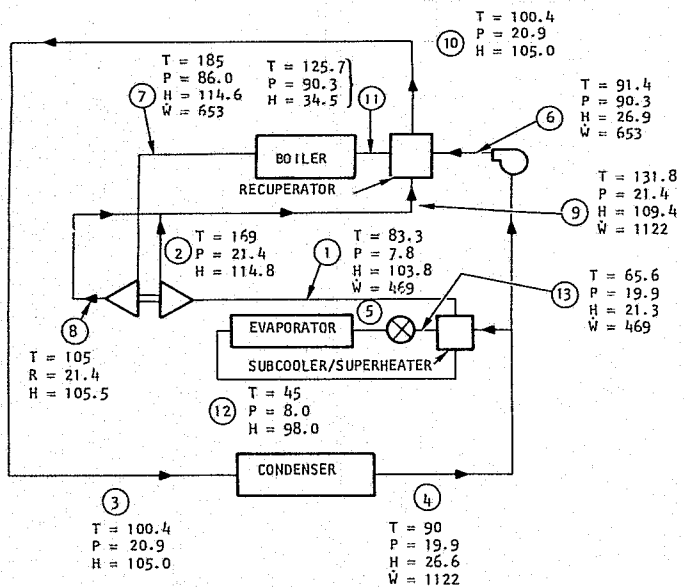

CHARACTERISTICS

	COMPRESSOR	TURBINE
FLOW, LB/HR	469	653
ΔH , BTU/LB	11.5	9.1
BOILER Q:	52,310 BTU/HR	
RECUPERATOR Q:	4960 BTU/HR	
SUPERHEATER Q:	2490 BTU/HR	
THERMAL COP:	0.69	

REMARKS

SOME COP AS BASELINE, SYSTEM COMPLEXITY NOT WARRANTED. NOT RECOMMENDED.

G. SUBCOOLER/SUPERHEATER - TURBINE AND COMPRESSOR RECUPERATORS

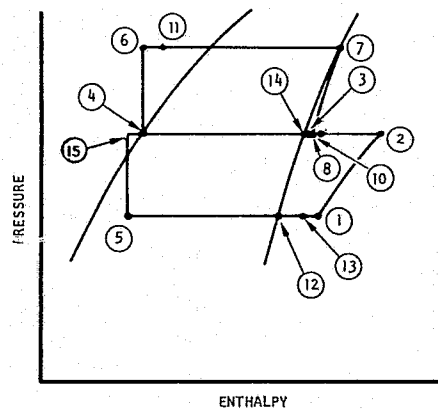
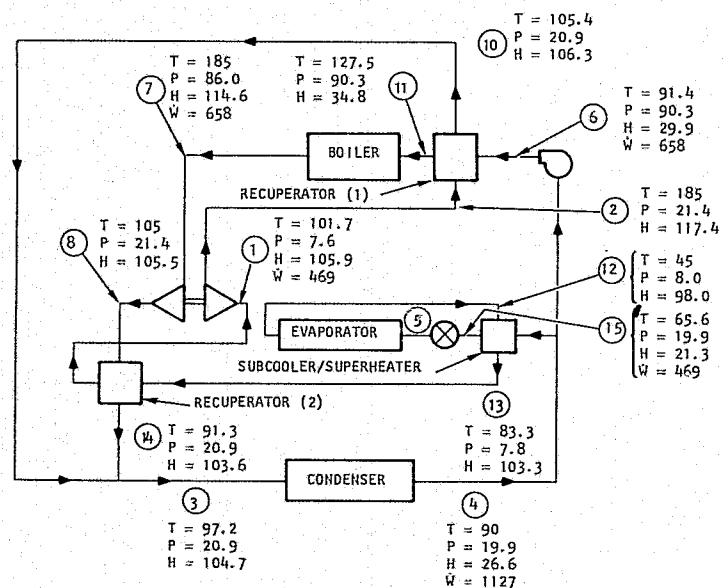

CHARACTERISTICS

	COMPRESSOR	TURBINE
FLOW, LB/HR	469	658
ΔH , BTU/LB	11.5	9.1
BOILER Q:	52,510 BTU/HR	
RECUPERATOR (1) Q:	5200 BTU/HR	
RECUPERATOR (2) Q:	1250 BTU/HR	
SUPERHEATER Q:	2490 BTU/HR	
THERMAL COP:	0.69	

REMARKS

HEAT EXCHANGER ΔP 's OFFSET BENEFITS OF HEAT RECOVERY. NOT RECOMMENDED.

FOLDOUT PLANE

S-98176

In all systems that were considered, the quantities of heat recovered are relatively small in comparison to the total heat input to the boiler. The maximum recuperator load shown represents only 10 percent of the boiler load. However, higher compressor work is necessary to overcome the additional heat exchanger pressure drops; simultaneously, the available load at the turbine decreases for the same reason. As a result, the turbine flow rate increases significantly and the net effect is a small change in overall system thermal COP.

No significant improvement in COP can be realized through the use of recuperators and/or subcooler/superheaters. The very small gain (0.02) shown for Concept E of Table 2-1 is at best marginal and does not warrant the addition of two heat exchangers and associated lines to the baseline system.



SECTION 3

OFF-DESIGN PERFORMANCE PREDICTION COMPUTER PROGRAM

GENERAL

The off-design computer program was developed to assess the performance of the Rankine air conditioner over ranges of ambient conditions and solar collector performance. The methodology used is depicted in Figure 3-1.

The computations are started by calculating a first set of cycle parameters using the design computer program. Simultaneous iteration of these parameters is performed based on the generalized Newton method of convergence until the flows, temperatures, heat loads, and turbine-compressor power and speed are satisfied. The computer output data include COP and system capacity, as well as turbomachine and system thermodynamic data.

This off-design program formed the basis for the complete system model described later.

ASSUMPTIONS

The design computer program is an integral part of the off-design program. Many of the subroutines of the design program are used in the off-design program. The assumptions summarized in Table 1 of AiResearch report 74-10996(7) apply for the equipment pertinent to the selected baseline. Major assumptions specific to the off-design computer program are listed below.

- (1) Once the initial conditions are calculated by the design program, the following flows are assumed to be constant for all operating conditions:

(a) Water flow through the boiler: $0.0009 \text{ m}^3/\text{sec}$ (13.8 gpm)

(b) Air flow through the evaporator: $0.4 \text{ m}^3/\text{sec}$ (850 cfm)

(c) Air flow through the condenser: $1.91 \text{ m}^3/\text{sec}$ (4050 cfm)

Figure 3-2 identifies the thermodynamic state points used in the thermodynamic calculations. The data listed above are from the design computer program (see computer printout in Figure 3-3).

- (2) Design point parameters used in the calculation of the initial (starting point) cycle parameters, heat exchanger characteristics, and air/water flow rates are defined in Table 3-1. Heat exchanger characteristics used by the off-design program are as follows:

(a) Evaporator--Face area: 0.160 m^2 (1.728 ft²);

Number of tube rows: 7.46--actually 8 tube rows
would be specified



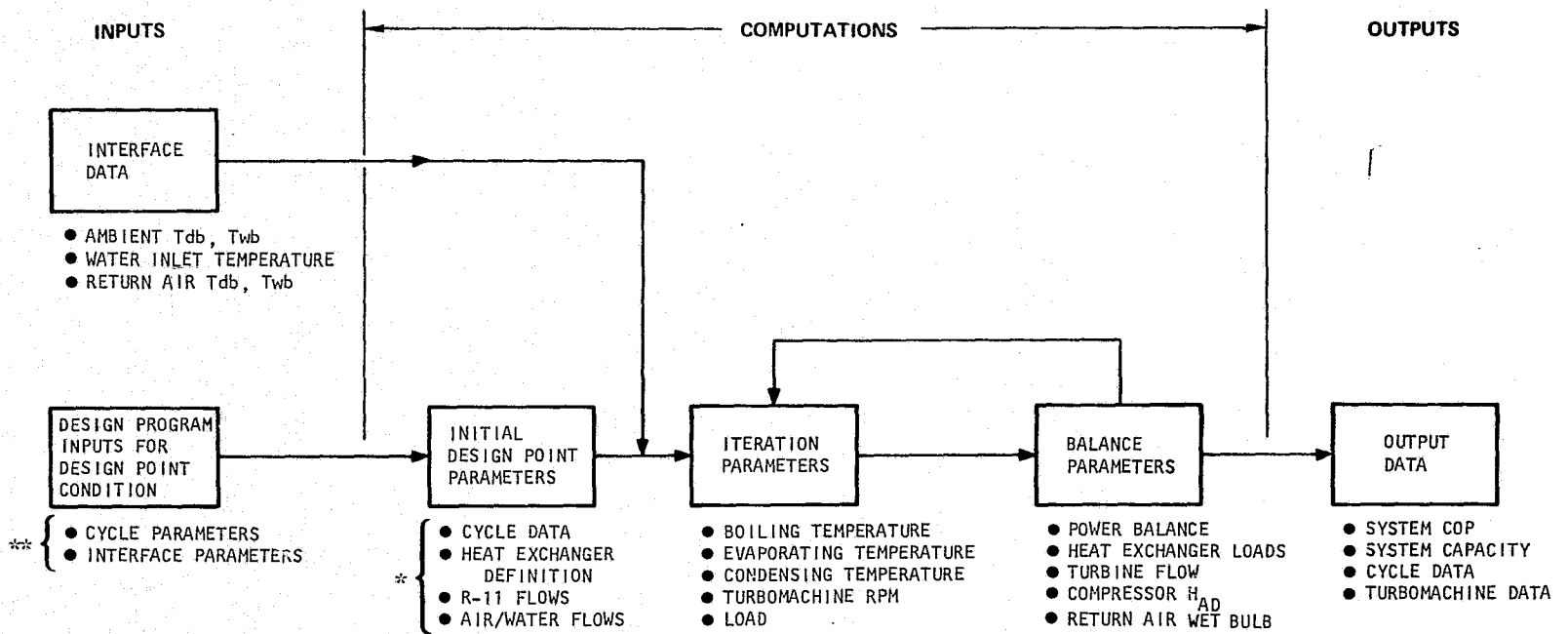

*See Figure 3-2

**See Table 3-1

Figure 3-1. Off-Design Computer Program Methodology

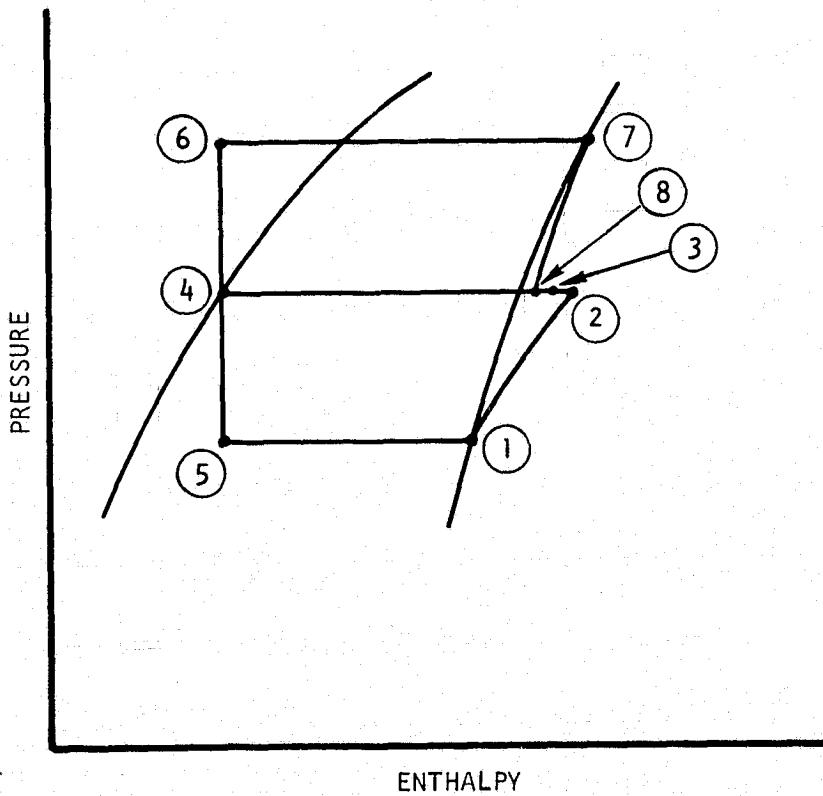
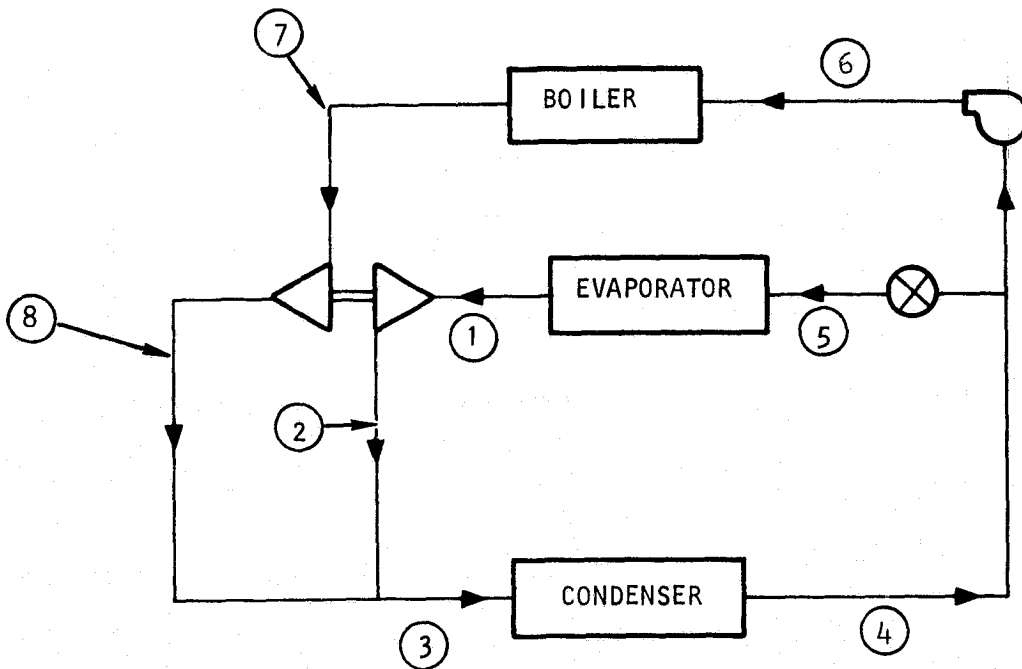

S-186

Figure 3-2. System Thermodynamic State Points



AIRESEARCH MANUFACTURING COMPANY
OF CALIFORNIA



12.28

SOLAR POWERED AIR CONDITIONING SYSTEM USING R-11
WET CONDENSER EMPLOYED RUN ON 21 OCT 75 AT 10:30:52

STATION/ID	TEMPERATURE DEG F	PRESSURE PSIA	ENTHALPY BTU/LB	FLOW RATE LB/HR	DENSITY LB/CU FT
1	45.0000	8.0000	98.0125	504.2193	.2066
2	122.1692	20.9527	108.0408	504.2193	.4807
3	110.6671	20.9527	106.4565	1096.6669	.4902
4	90.0000	19.9550	26.6150	1096.6669	.0000
5	47.0619	8.0000	26.6150	504.2193	.0000
6	91.3622	20.9527	26.6150	592.4476	.0000
7	185.0000	86.0175	114.5950	592.4476	1.9447
8	101.2480	20.9527	105.1118	592.4476	.4986

HEAT EXCHANGER	HOT FLUID FLO (LB/HR)	HOT FLUID TEMP (F) IN	HOT FLUID TEMP (F) OUT	COLD FLUID FLO (LB/HR)	COLD FLUID TEMP (F) IN	COLD FLUID TEMP (F) OUT	HA (HTU/HR/ (DEG F)	WEIGHT (LB) HX	COST (US \$) HX	FAN HP (HP=2L)	FAN FLOW (GAL/HR)	W (BTU/HR)	WET RULB (F) IN	WET RULB (F) OUT		
EVAP	3815.	80.0	55.0	504.	47.1	45.0	.00	35.8	32.6	27.2	42.7	.86	179.0	36000.	67.0	53.4
BOILER	6927.	200.0	192.5	592.	91.8	185.0	4801.57	35.5	.0	54.3	.0	.00	.0	51954.		
CONDNSR	1097.	110.9	90.0	18242.	95.0	*****	.00	41.8	108.4	109.8	124.3	.82	831.0	67562.	75.0	60.0

COEF OF PERFORMANCE		TURBO-COMPRESSOR		ELECTRIC POWER REQD (WATT)		SYSTEM COST (\$)	
POWER COP	.108	COMPX DIA (IN)	2.176	EVAP FAN	178.997	FACTORY COST	822.
REFRIG COP	7.120	COMPX EFF	.730	CONDNSR FAN	830.940		
SYSTEM COP	.691	RPM	58444.	CL TOWER FAN	.000	USER COST	3055.
		TURBN DIA (IN)	2.176	WATER PUMP	.87.562		
		TURBN EFF	.771	FREQN PUMP	49.658		
				TOTAL	1147.197		

Figure 3-3. Baseline System Performance at Design Point-- Design Computer Program Data

TABLE 3-1

BASELINE DESIGN CONDITIONS

Parameter	Design Condition
Water inlet temperature to the boiler	366.5 K (200 F)
R-11 boiling temperature	358.3 K (185 F)
Ambient air dry bulb temperature	308.2 K (95 F)
Ambient air wet bulb temperature	297 K (75 F)
R-11 condensing temperature	305.5 K (90 F)
Room return air dry bulb temperature	299.8 K (80 F)
Room return air wet bulb temperature	292.6 K (67 F)
R-11 evaporating temperature	280.4 K (45 F)
Condenser approach temperature	5.6 K (10 F)
Evaporator approach temperature	5.6 K (10 F)
Boiler approach temperature	4.2 K (7.5 F)
System capacity	10.5 kw (3 tons)

(b) Condenser heat transfer area: 3.85 m^2 (41.4 ft^2)

(c) Boiler UA: $27.2 \text{ kw/m}^2\text{K}$ (4802 Btu/hr ft^2F)

- (3) Heat exchanger pressure drop is assumed to be 5 percent of the inlet pressure as in the design program.
- (4) The thermodynamic cycle calculations assume no superheat at boiler or evaporator outlets; similarly, no subcooling is assumed at the condenser outlet. The small quantities of heat involved in providing adequate superheat and subcooling for proper operation of the turbo-compressor and R-11 pump will not affect system performance significantly.
- (5) The R-11 γ , specific heat ratio, is calculated from the pressure-enthalpy data with the following equations:



- for the compressor,

$$\Delta H_C = \frac{P_{IN}}{\rho \times 778.3} \left(\frac{\gamma}{\gamma - 1} \right) \left[\left(\frac{P_{OUT}}{P_{IN}} \right)^{\frac{\gamma - 1}{\gamma}} - 1 \right]$$

- for the turbine,

$$\Delta H_T = \frac{P_{IN}}{\rho \times 778.3} \left(\frac{\gamma}{\gamma - 1} \right) \left[1 - \left(\frac{P_{IN}}{P_{OUT}} \right)^{\frac{\gamma - 1}{\gamma}} \right]$$

where ΔH is the isentropic enthalpy difference between the inlet and outlet pressures, (Btu/lb)

P is the fluid pressure (lb/ft²) at inlet (IN) and outlet (OUT)

ρ is the inlet fluid density (lb/ft³)

- (6) Compressor maps relating flow, adiabatic head, speed, and efficiency were developed and are presented and discussed in Section 4 (Figure 4-5).
- (7) Turbine performance maps were also developed and are given in Section 4 (Figure 4-2).
- (8) A maximum speed of 76,000 rpm was selected for the turbomachine.
- (9) The turbomachine mechanical efficiency is taken as 90 percent, which is representative of this size machine.
- (10) The power loop efficiency, PCOP, is defined as follows:

$$PCOP = \frac{\text{turbine output power}}{\text{boiler heat input}}$$

- (11) The refrigeration loop efficiency, RCOP, is defined as

$$RCOP = \frac{\text{evaporator load}}{\text{compressor power}}$$

- (12) The overall system efficiency, SCOP, is calculated from

$$SCOP = \frac{\text{evaporator load}}{\text{boiler load}}$$

COMPUTER PROGRAM LISTING

A listing of the off-design computer program is presented in Appendix A, which also includes the nomenclature of the input data. The program was written in Fortran V language for use on the UNIVAC 1108 computer. An example of the output data is shown in Figure 3-4. This run was made using a compressor designed to yield maximum efficiency at design point. Further discussions





SOLAR POWERED AIR CONDITIONING SYSTEM USING R-11
WET CONDENSER EMPLOYED RUN ON 21 OCT 75 AT 10:30:53

STATION/ID	TEMPERATURE DEG F	PRESSURE PSIA	ENTHALPY BTU/LB	FLOW RATE LB/HR	DENSITY LB/CU FT
1	45.0584	8.0113	98.0198	504.3158	.2069
2	122.1692	21.2704	108.1552	504.3158	.4883
3	110.8671	21.2704	108.7961	1158.5857	.4980
4	90.8300	20.2575	20.7922	1158.5857	.0000
5	47.1231	8.4119	20.7922	504.3158	.0000
6	92.0855	88.4574	27.0512	654.2699	.0000
7	183.4905	84.2552	114.4385	654.2699	1.9046
8	101.2480	21.2704	105.7485	654.2699	.4986

HEAT EXCHANGER	HOT FLUID		COLD FLUID		UA (BTU/HR/DEG F)	WEIGHT (LB)		COST (US \$)		FAN CP (IN-H2O)	FAN POWER (WATT)	Q (BTU/HR)	WET BULB (F)	
	FLOW (LB/HR)	TEMP (F) IN OUT	FLOW (LB/HR)	TEMP (F) IN OUT		HX	FAN	HX	FAN				IN	OUT
EVAP	3815.	80.0 55.0	504.	47.1 45.1	.00	35.8	32.6	27.2	42.7 .86		179.0	35921.	67.0	53.4
BOILER	6927.	200.0 191.7	654.	92.1 183.5	4801.57	35.5	.0	54.3	.0 .00		.0	57174.		
CONDNSR	1159.	110.9 98.6	10242.	95.0*****	.00	91.8	108.4	109.8	124.3 .82		831.0	92787.	75.0	80.2

COEF OF PERFORMANCE		TURBO-COMPRESSOR		ELECTRIC POWER REQD(WATT)		SYSTEM COST(\$)	
POWER COP	.099	COMPX DIA(IN)	2.425	EVAP FAN	178.997	FACTORY COST	822.
REFRIG COP	7.028	COMPX EFF	.709	CONDNSR FAN	830.980	USER COST	3055.
SYSTEM COP	.626	RPM	58582.	GL TOWER FAN	.000		
		TURBN DIA(IN)	1.766	WATER PUMP	87.562		
		TURBN EFF	.800	FREON PUMP	49.658		
				TOTAL	1147.197		

NOTE: BASELINE DESIGN CONDITIONS WITH COMPRESSOR OPTIMIZED FOR MAXIMUM DESIGN POINT EFFICIENCY. SEE COMPRESSOR PERFORMANCE MAP OF FIGURE 4-1.

Figure 3-4. Example of Output Data--Off-Design Computer Program Data

of compressor selection presented in Section 4 will show that this compressor was modified to extend the range of operation of the system. This particular printout is given for purposes of comparison with the design computer program.

The output data format is the same as that for the design program and also includes some of the data generated in the initial calculations of the starting point. These data define the baseline system. The output data include the following:

- (a) Refrigerant temperature, pressure, enthalpy, flow rate, and density at the system stations defined in Figure 3-2
- (b) Heat exchanger flows, temperatures, heat loads, and UA requirement
- (c) Heat exchanger weight and cost
- (d) Fan characteristics including flow, pressure rise, and power
- (e) Wet bulb temperature of the air at inlet and outlet of the evaporator and condenser where applicable
- (f) Cycle characteristics: power loop efficiency, refrigeration loop COP, and overall system COP. COP is defined as follows:

$$\text{Refrigeration loop COP} = \frac{\text{refrigeration load}}{\text{compressor power input}}$$

$$\text{Overall system COP} = \frac{\text{refrigeration load}}{\text{boiler heat input}}$$

- (g) Turbine and compressor characteristics: efficiency, impeller diameter, and speed
- (h) Electric power requirements for the fans and pumps
- (i) System cost data

The program was written using the English system of units as defined in the nomenclature and the output data printouts.

DESIGN AND OFF-DESIGN COMPUTER PROGRAM DATA

Pertinent data from the computer printouts shown in Figure 3-3 and 3-4 are listed in Table 3-2, which provides a direct comparison of the data obtained by the design and off-design computer programs.

Examination of the data shows nearly identical cycle temperatures. The largest difference is in the boiling temperature, where the off-design program value is lower by 1.0 K (1.5 F). Compressor flow is the same in both cases. However, the compressor map used for off-design performance prediction yields

TABLE 3-2

SUMMARY OF DESIGN AND OFF-DESIGN COMPUTER PROGRAM DATA

Design Conditions: See Table 3-1

Fixed System Data (From Design Program):

- Evaporator

Face area: 0.160 m² (1.728 ft²)

Number of tube rows: 7.46

Air flow: 0.4 m³/sec (850 cfm)

- Boiler

Heat transfer conductance: 27.2 kw/m²K (4802 Btu/hr ft²F)

Water flow: 0.0009 m³/sec (13.8 gpm)

- Condenser

Heat transfer area: 3.85 m² (41.4 ft²)

Airflow: 1.91 m³/sec (4050 cfm)

Performance Data:

Parameter	Design Computer Data	Off-Design Computer Data
Evaporating temperature, K (F)	280.6 (45)	280.6 (45.1)
Condensing temperature, K (F)	305.6 (90)	306 (90.8)
Boiling temperature, K (F)	358.3 (185)	357.5 (183.5)
Compressor flow, kg/sec (lb/hr)	0.064 (504)	0.064 (504)
Turbine flow, kg/sec (lb/hr)	0.075 (592)	0.083 (654)
Compressor efficiency, percent	74	71
Turbine efficiency, percent	77	80
Turbomachine speed, rpm	58,400	58,400
System capacity, kw (tons)	10.5 (3.0)	10.5 (3.0)
Power loop efficiency, percent	11	10
Refrigeration loop COP	7.1	7.0
Overall system COP	0.69	0.63



a slightly lower efficiency (0.71 vs 0.74). Higher turbine flows were obtained, although the turbine efficiency predicted by the off-design program is higher than that estimated by the procedure used for initial selection of the turbine. This is attributed to minor discrepancies found in the R-11 thermodynamic data. Since more flow is necessary at the turbine, the overall system COP is lower by about 10 percent than predicted by the design computer program. The lower value is believed to be more accurate.



SECTION 4

TURBOCOMPRESSOR OPTIMIZATION

GENERAL

Predicting system performance for conditions other than the design point requires that the efficiency of the compressor and turbine be estimated over a range of flows, pressure ratios, and rotational speed. Compressor and turbine performance maps have been developed for the baseline machine using experimental data obtained on similar units.

Problem statements for the preliminary design of the compressor and turbine were derived from the baseline system optimized for the following conditions using the design computer program:

Water temperature at boiler inlet: 366.7 K (200 F)

Ambient air dry bulb temperature: 308.3 K (95 F)

Ambient air wet bulb temperature: 297.2 K (75 F)

Return air dry bulb temperature: 300 K (80 F)

Return air wet bulb temperature: 292.8 K (67 F)

Under these conditions, the design computer program, using the compressor and turbine models described in the screening analysis report (AIResearch report 74-10996(7)), furnished the design point data listed in Table 4-1.

TABLE 4-1

COMPRESSOR AND TURBINE PROBLEM STATEMENTS

	Compressor	Turbine
Rotational speed, rpm	58,440	58,440
Flow rate, kg/sec (lb/hr)	0.064 (504)	0.075 (592)
Inlet temperature, K (F)	280.6 (45)	363.8 (195)
Inlet pressure, kN/m ² (psia)	55.2 (8.0)	592.9 (86.0)
Outlet temperature, K (F)	323.4 (122.2)	311.8 (101.2)
Outlet pressure, kN/m ² (psia)	144.9 (21.0)	144.9 (21.0)
Efficiency, percent	74	77
Diameter, cm (in.)	5.54 (2.18)	5.54 (2.18)



The turbine inlet temperature used in turbine design is 5.6 K (10 F) higher than that obtained with the design computer program. This program assumes saturated conditions at turbine inlet. In practice, superheat must be provided to prevent condensation from the bulk of the fluid as the refrigerant expands isentropically in the turbine nozzle.

DESIGN FOR MAXIMUM DESIGN POINT EFFICIENCY

Preliminary design of the compressor indicated that the efficiency obtained using the procedure cited in AiResearch report 74-10996(7) was slightly optimistic. More detailed calculations gave a compressor diameter of 6.17 cm (2.43 in.) at design speed; design point efficiency is predicted at 71 percent. The compressor map is shown in Figure 4-1. These data are considered in good agreement with the data obtained from the preliminary estimates.

The turbine was designed to match the speed and power requirements of the compressor. In the performance of the preliminary design of the turbine, discrepancies were found in the R-11 thermodynamic data used. These discrepancies are related to the values of R and γ in the region of the vapor dome.

The design program uses a value of $\gamma = 1.11$ published by Allied Chemicals (Genetron II thermodynamic properties, 1957). The off-design program calculates the value of γ from the pressure-enthalpy data contained in the same reference, using the equations given previously. These discrepancies were corrected in final design but were found to have an important effect on turbine performance. As a result, higher turbine flow rates were necessary to furnish the power necessary to drive the compressor at the design point defined in Table 4-1.

The turbine is a radial inflow machine with curved blading at the tip to reduce reaction. Turbine diameter is 4.5 cm (1.77 in.), and turbine efficiency at design point is estimated at 81 percent. This is slightly higher than predicted and offsets the detrimental effect of the lower compressor performance. The overall efficiency of the turbocompressor remains about the same at 0.52 (including a 90 percent mechanical efficiency). Design point flow rate is estimated at 297 kg/hr (654 lb/hr); this represents a 10 percent increase over the value predicted by the design procedure used previously.

The turbine performance maps are presented in Figure 4-2. The flow factor (F_F) shown is defined by

$$\frac{W\sqrt{T_o}}{A P_o} = (F_F) \frac{\sqrt{\gamma g/R}}{\left(1 + \frac{\gamma-1}{2}\right)^{(\gamma+1)/(2\gamma-2)}}$$

where W = flow, lb/sec

A = nozzle area, 0.049 in.²

T_o = inlet temperature, R

P_o = inlet pressure, psia



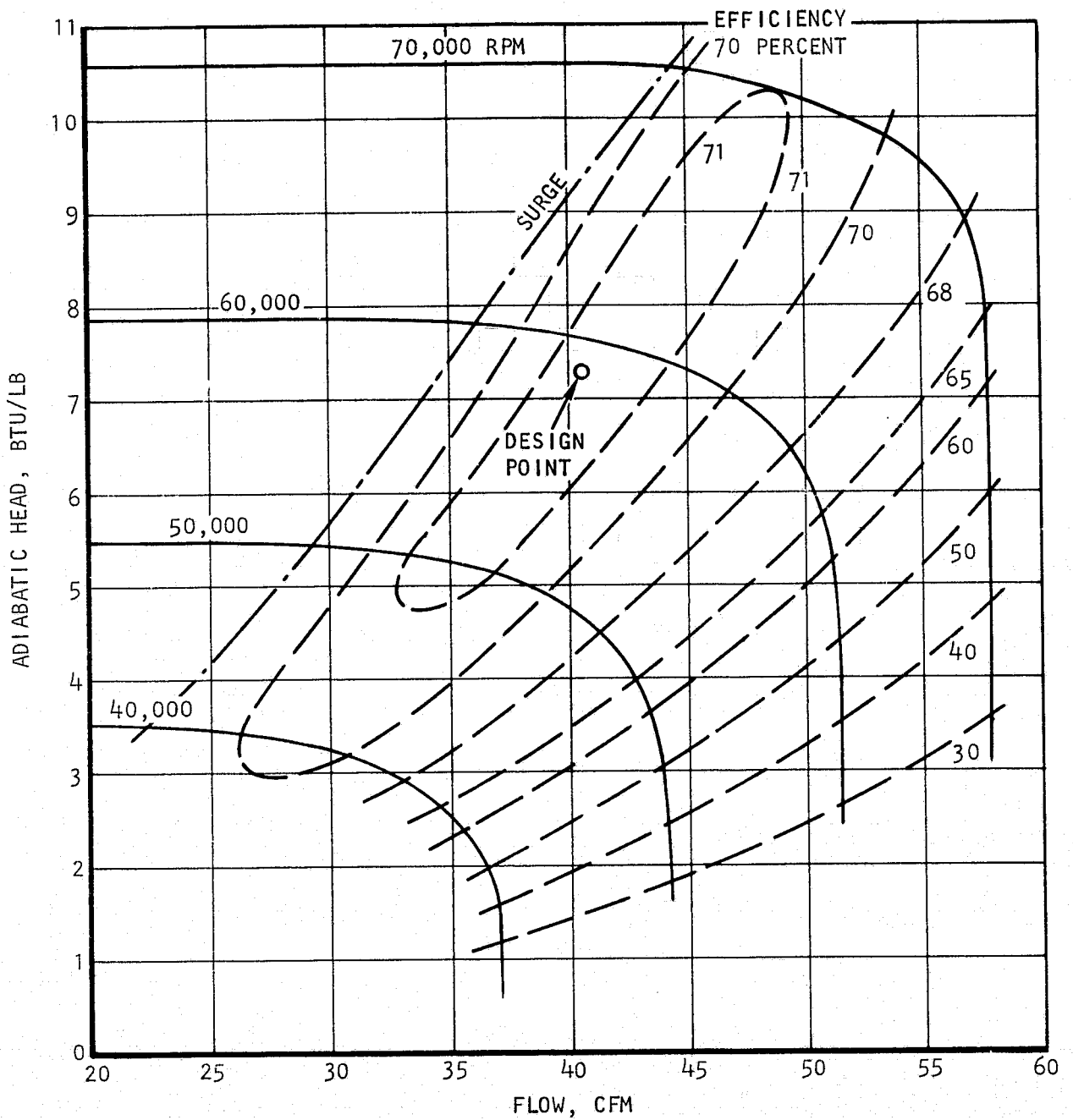

S-341

Figure 4-1. Compressor Performance for Maximum Design Point Efficiency



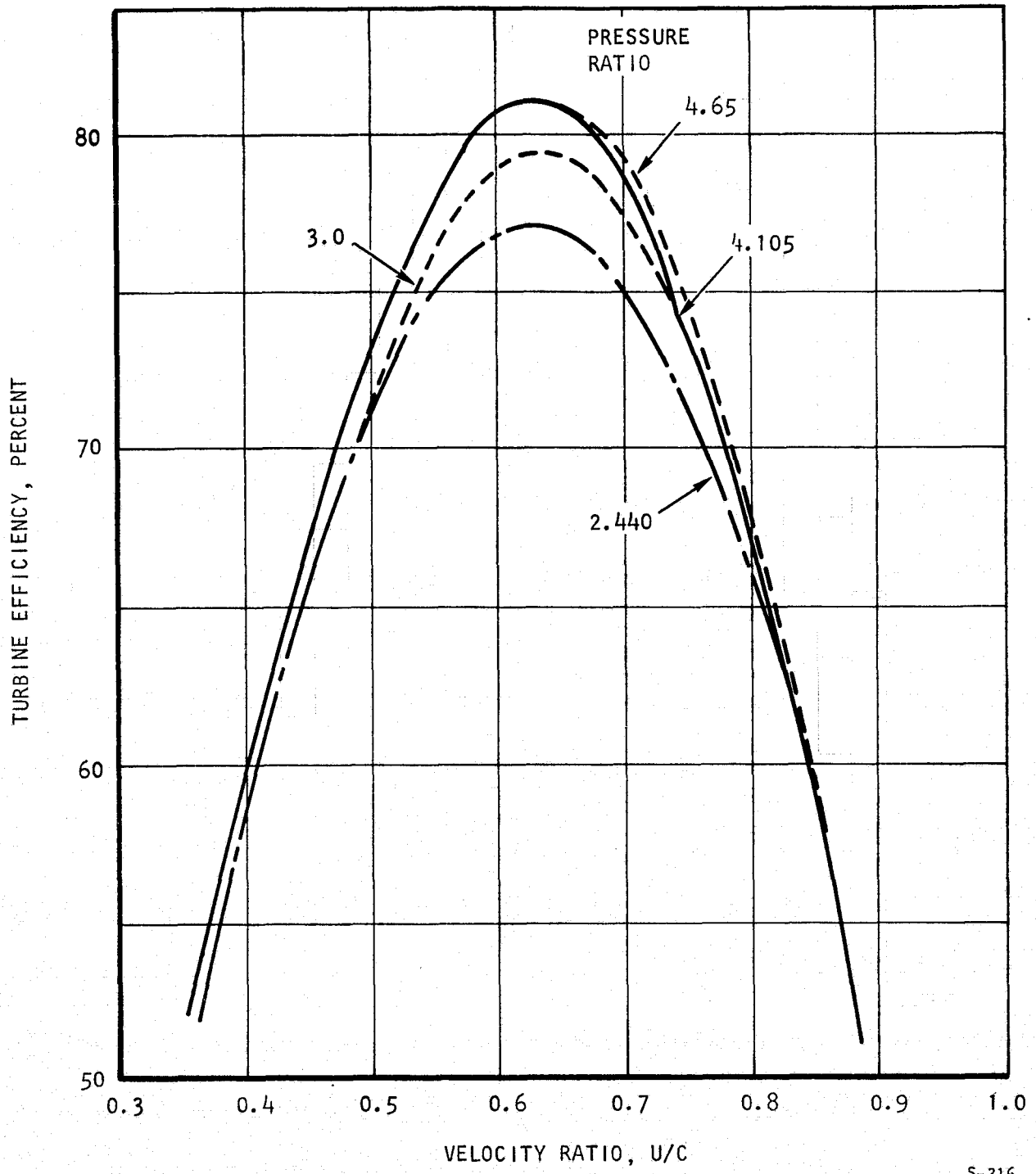

S-316

Figure 4-2. Turbine Performance for Maximum Design Point Efficiency

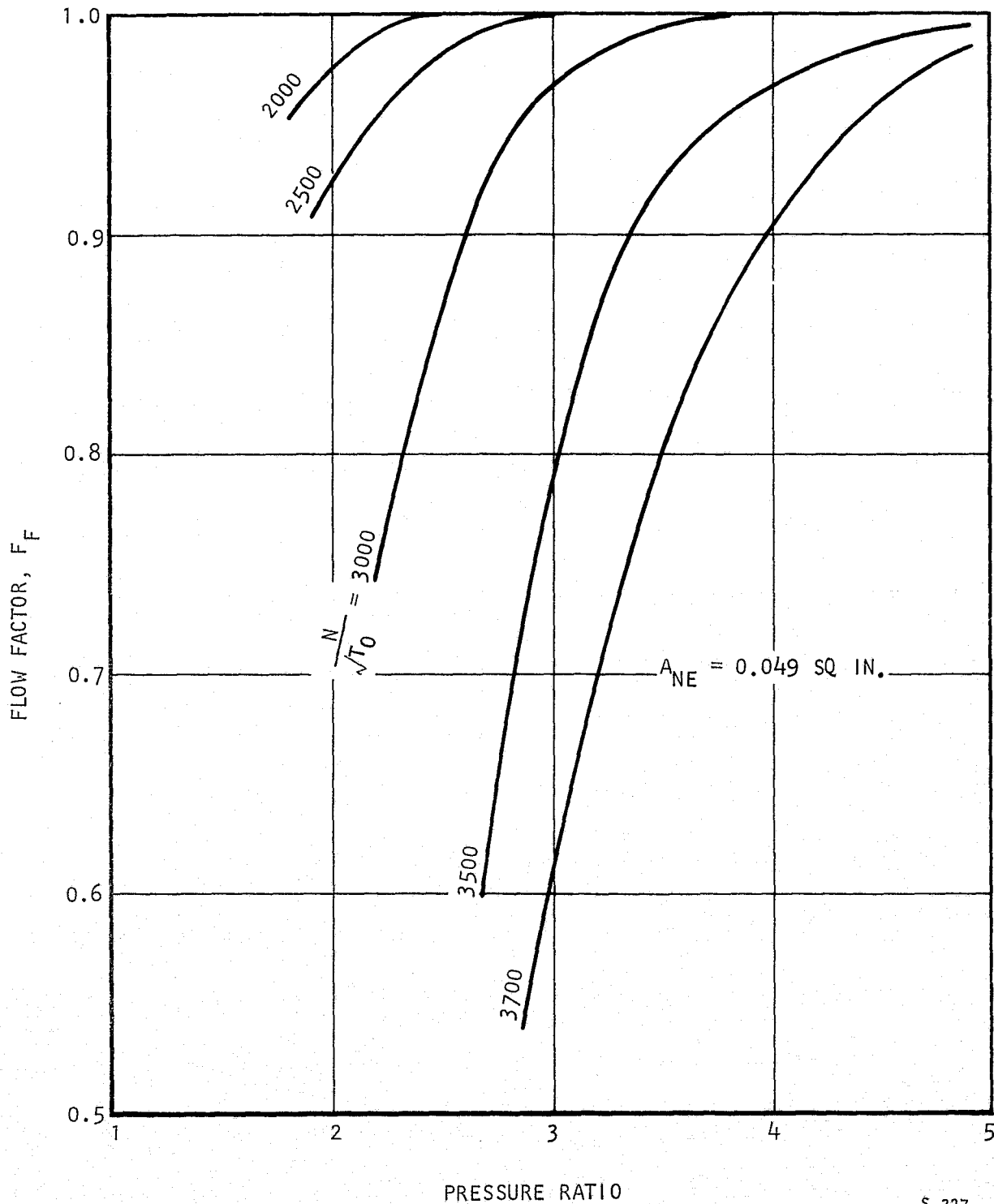

S-327

Figure 4-2. (Continued)



$Y = 1.056$ (obtained from p-H diagram)

$R = 9.9$

$g = 32.2$

The velocity ratio, U/C_o , can be calculated from the following equations:

$$C_o = \sqrt{2g \text{ Had}} \quad \text{and} \quad U = \frac{DN}{229.2}$$

where: Had = adiabatic head, ft-lb/lb

D = turbine diameter, 1.77 in.

N = turbine speed, 58,440 rpm

The turbocompressor design was evaluated using the computer program described in Section 3. Parametric data were generated to cover a broad range of values of the following parameters:

- (1) Water temperature at boiler inlet
- (2) Ambient wet bulb temperature
- (3) Residence wet bulb temperature

Typical data are shown in Figure 4-3 for a residence wet bulb temperature of 291.1 K (64 F). Corresponding to the system performance of Figure 4-3, Figure 4-4 shows the operational lines of the compressor superimposed on the compressor map.

These plots show that augmentation will be necessary for operation at boiler temperatures below 361.1 K (190 F) and ambient wet bulb temperatures over 297.2 K (75 F). Furthermore, water temperatures on the order of 352.8 K (175 F) would be necessary for operation of the baseline system (without augmentation) at ambient wet bulb temperatures of 294.4 K (70 F).

This was felt to be too restrictive since ambient wet bulb temperatures between 294.4 K (70 F) and 297.2 K (75 F) are prevalent over a large portion of the country during the summer months. Consequently, it has been necessary to compromise the efficiency of the compressor at design point to broaden the useful operating range of the system. This was accomplished by iterating around the compressor design to modify its flow characteristics.

PERFORMANCE WITH BROAD RANGE COMPRESSOR

The broad range compressor was designed for higher speed (63,000 rpm) at the design point conditions of Table 4-1. Investigation of the compressor and turbine design requirements indicated that the compressor change would



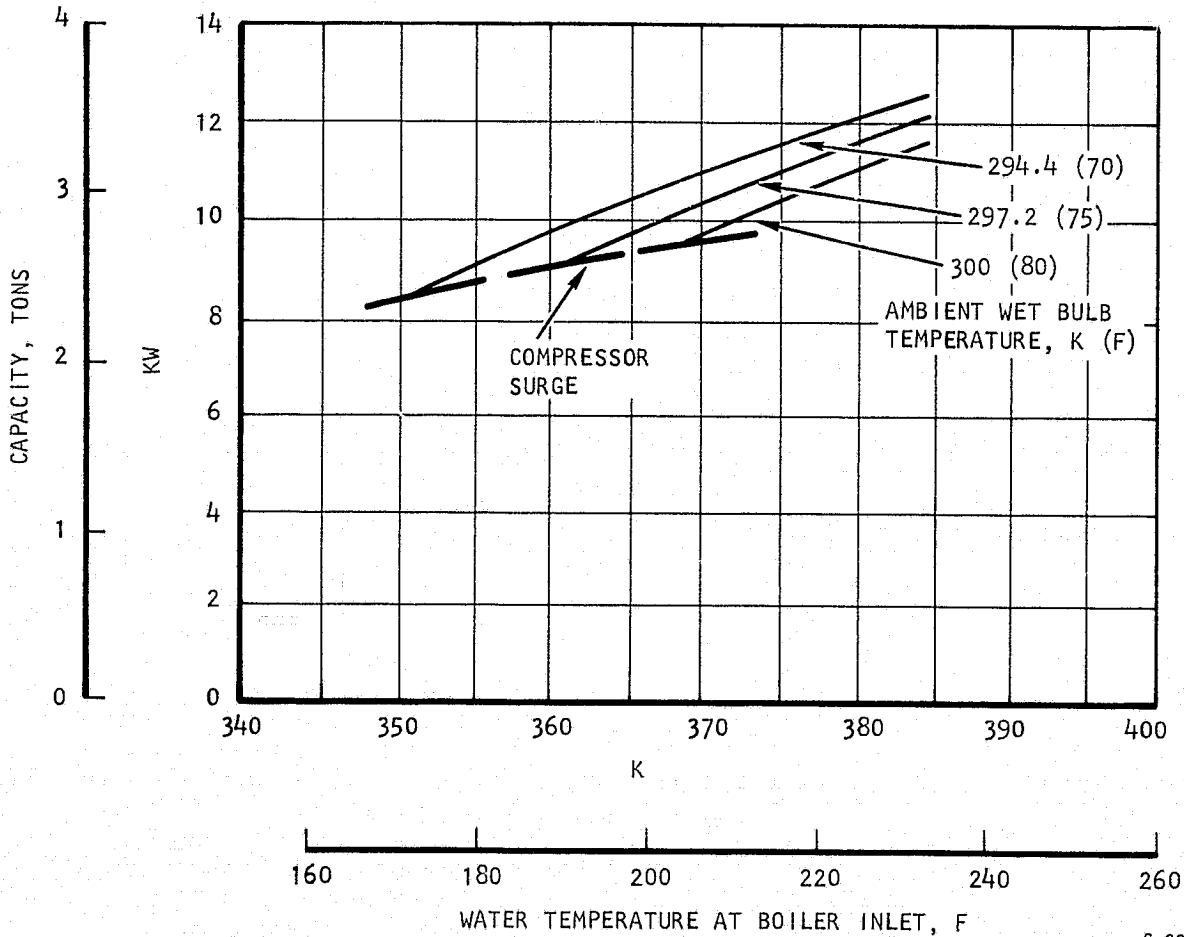
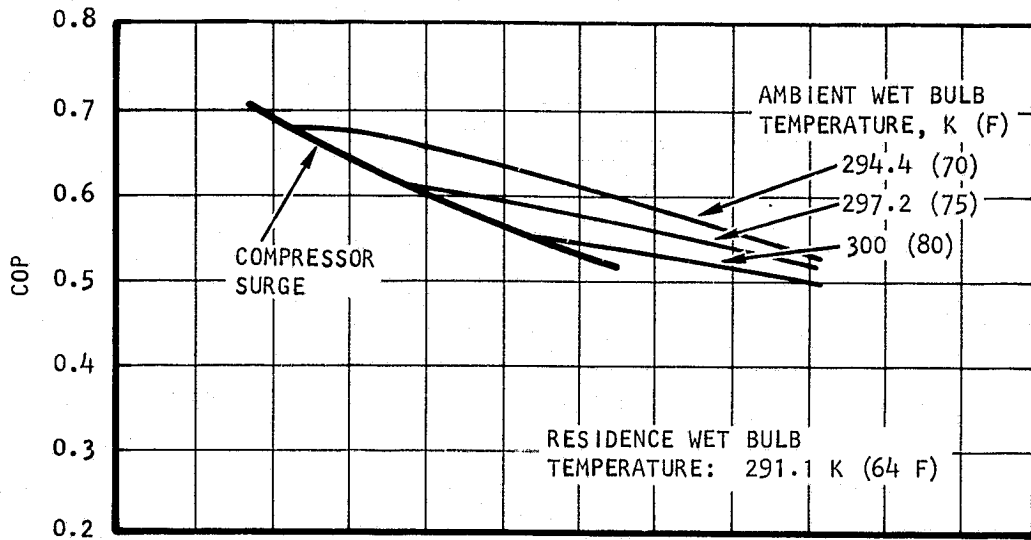
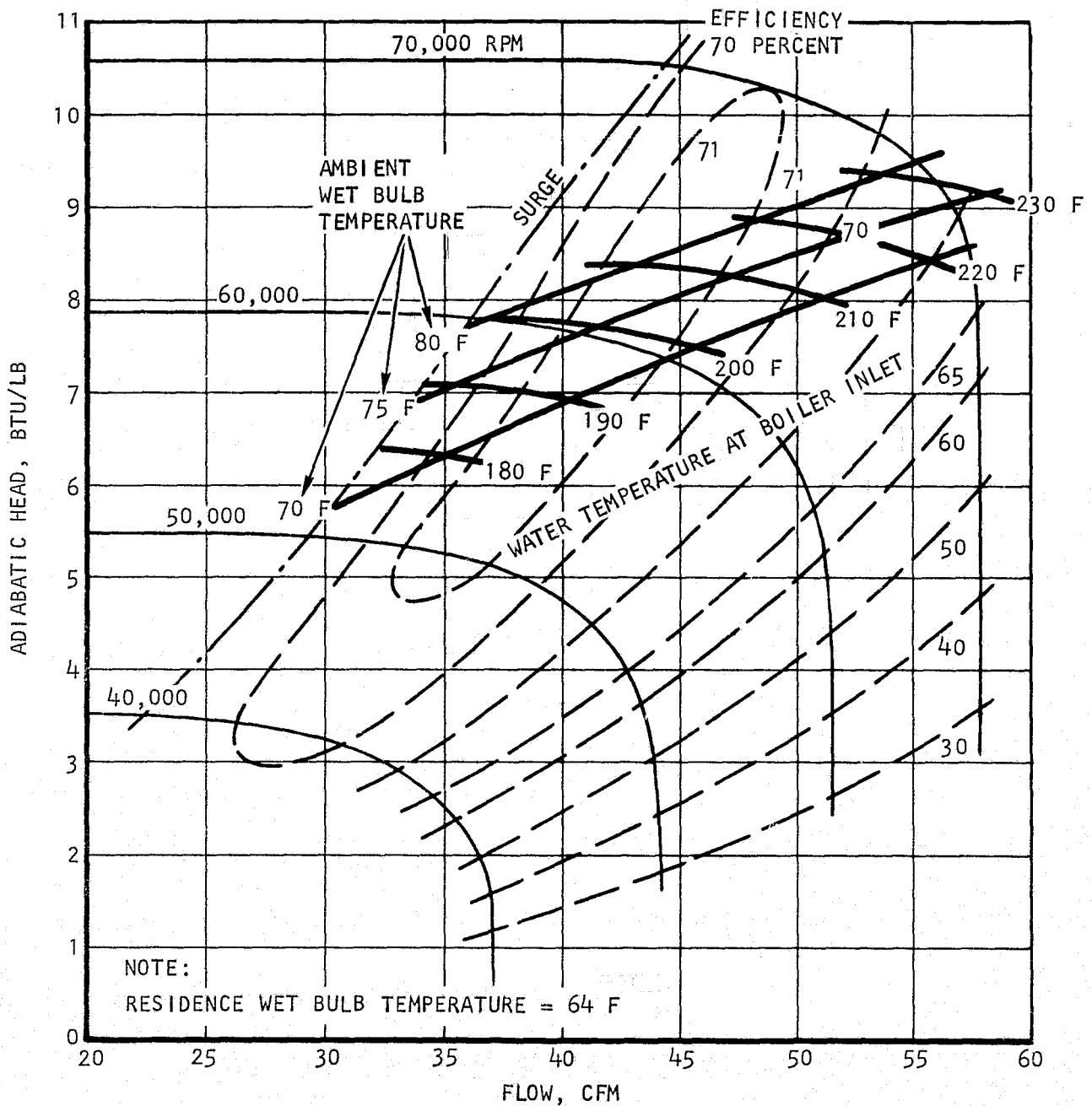

Figure 4-3. Typical System Performance--Maximum Design Point Efficiency Compressor





S-342

Figure 4-4. Typical Operational Range--Maximum Design Point Efficiency Compressor



involve only a minimal change in the turbine design. Moreover, the diameter of the compressor would remain about the same due to Reynolds number and size correction factors. Since the changes are well within the accuracy of the data desired, the turbine characteristics of Figure 4-2 were used with the revised compressor design.

The performance map of the broad range compressor was incorporated in the off-design computer program, and again operational characteristics were determined. Figure 4-5 shows the same data as Figure 4-4 with the revised compressor.

At heat source temperatures lower by at least 11.1 K (20 F), operation is possible with the broad range compressor. Restrictions are imposed by stress limitations, however, in the high water temperature range. Furthermore, the compressor efficiency at higher temperature is decreased considerably. This does not appear to be a significant disadvantage in the present application, where temperatures much above the boiling point of water are undesirable in view of the water tank pressurization that would be necessary to prevent boiling.

The performance map in Figure 4-5 was used to characterize the baseline system compressor.

SYSTEM DESIGN POINT PERFORMANCE WITH BROAD RANGE COMPRESSOR

Figure 4-6 is an off-design computer printout of the predicted performance of the system with the broad range compressor. Pertinent data from the printout are shown in Table 4-2, which constitutes an extension of Table 3-2. The system operating point in terms of cycle temperatures is practically the same with the two compressors, although the broad range compressor efficiency is lower by about 3 percent.

The power loop efficiency remains the same, even at the higher turbine speed. However, a reduction in flow in the refrigeration loop is noted, which results in a slight drop in system capacity, from 10.5 kw (3 tons) to 10.3 kw (2.94 tons). The combined effects of lower compressor efficiency and lower refrigeration loop capacity result in a slightly lower overall COP at design point. Referring to Figure 4-5, it is anticipated that higher system COP's will be obtained from the machine at lower water temperatures than design point.



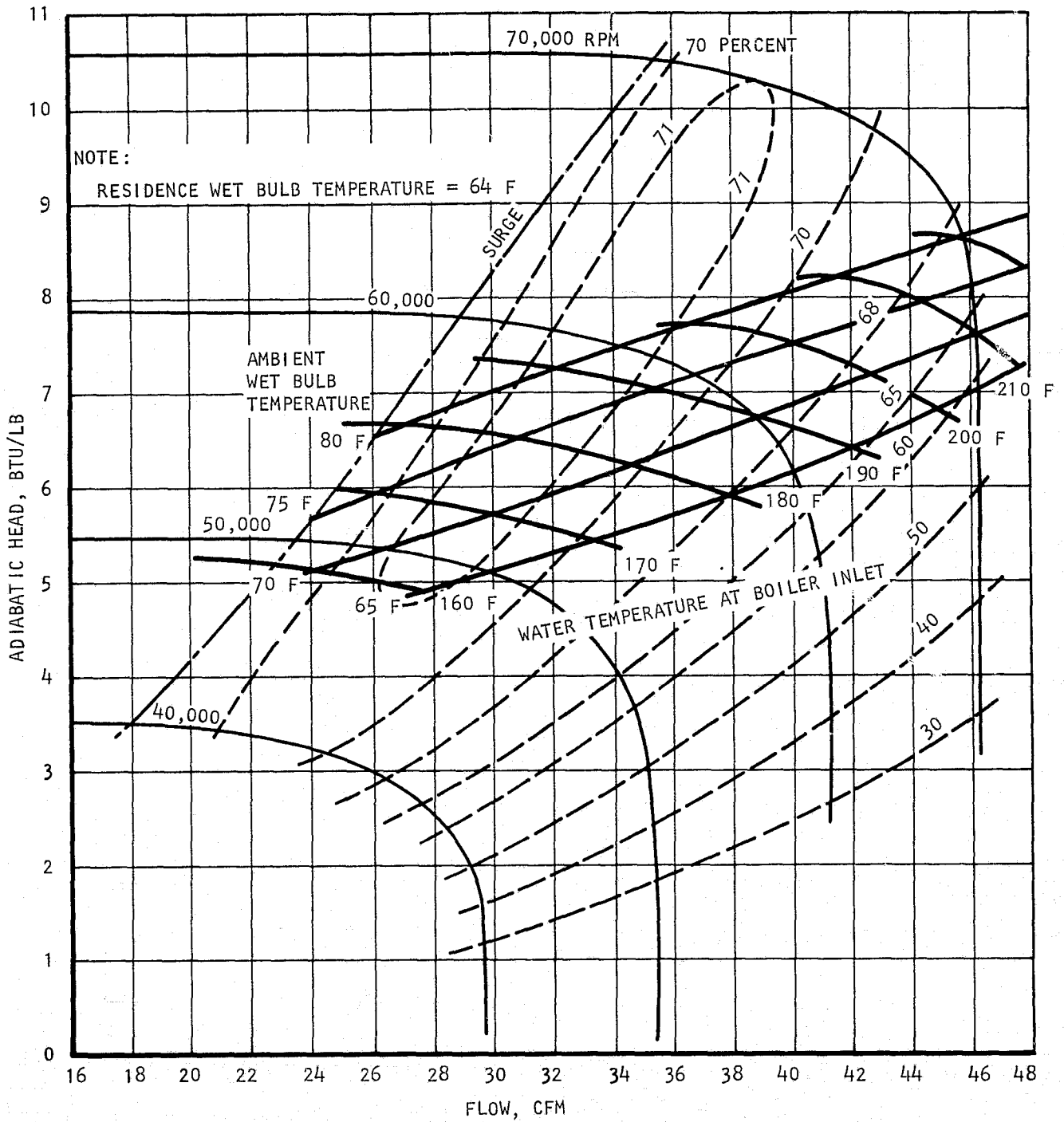

S-144

Figure 4-5. Typical Operation with Broad Range Compressor





SOLAR POWERED AIR CONDITIONING SYSTEM USING R-11
NET CONDENSER EMPLOYED RUN ON 23 OCT /75 AT 11:27:38

STATION/ID	TEMPERATURE DEG F	PRESSURE PSIA	ENTHALPY BTU/LB	FLOW RATE LB/HR	DENSITY LB/CU FT
1	45.5426	8.1131	98.0850	494.0519	.2093
2	126.4281	21.2223	108.4679	494.0519	.4836
3	117.4745	21.2223	106.8999	1148.1006	.4911
4	90.7042	20.2117	26.7653	1148.1006	.0000
5	47.6736	8.5187	24.7653	494.0519	.0000
6	41.9362	8.4406	27.0245	654.0486	.0000
7	183.4911	84.2554	114.4366	654.0486	1.9046
8	101.2460	21.2223	105.7154	654.0486	.4986

HEAT EXCHANGER	HOT FLUID		COLD FLUID		UA (BTU/HR/DEG F)	WEIGHT (LB)		COST (US \$)		FAN DP (IN=H2O)		FAN POWER (WATT)	Q (BTU/HR)	WET BULB(F)	
	FLC (LB/HR)	TEMP(F) IN OUT	FLC (LB/HR)	TEMP(F) IN OUT		HX	FAN	HX	FAN	IN	OUT				
EVAP	3815.	80.0	55.0	44.7	45.6	.00	35.8	32.6	27.2	42.7	.86	179.0	35236.	67.0	53.4
BOILER	5927.	200.0	191.7	65.4	183.5	4801.57	35.5	.0	54.3	.0	.00	.0	57172.		
CONDENSER	1148.	117.5	90.7	102.2	95.0****	.00	91.8	108.4	109.8	124.3	.82	831.0	92007.	75.0	80.2

COEF OF PERFORMANCE		TURBO-COMPRESSOR		ELECTRIC POWER REQD(WATT)		SYSTEM COST(\$)	
POWER COP	.100	COMPR DIA(IN)	2.425	EVAP FAN	178.997	FACTORY COST	822.
REFRIG COP	6.864	COMPR EFF	.680	CONDNSR FAN	830.980	USER COST	3055.
SYSTEM COP	.614	RPM	61316.	CL TOWER FAN	.000		
		TURBO DIA(IN)	1.766	WATER PUMP	87.562		
		TURBO EFF	.301	FREON PUMP	49.658		
				TOTAL	1147.197		

COMPRESSOR FLOW IN CFM = 39.34 ADIABATIC HEAD IN BTU/LB = 7.05

- NOTES: 1. DESIGN POINT INTERFACE PARAMETERS
2. COMPRESSOR MAP OF FIGURE 4-5

Figure 4-6. System Performance with Broad Range Compressor

TABLE 4-2

SYSTEM PERFORMANCE WITH DESIGN POINT AND BROAD RANGE COMPRESSORS

Design Conditions: See Table 3-1

Fixed System Data (From Design Program):

- Evaporator

Face area: 0.160 m² (1.728 ft²)
 Number of tube rows: 7.46
 Air flow: 0.4 m³/sec (850 cfm)

- Boiler

Heat transfer conductance: 27.2 kw/m²K (4802 Btu/hr ft²F)
 Water flow: 0.0009 m³/sec (13.8 gpm)

- Condenser

Heat transfer area: 3.85 m² (41.4 ft²)
 Airflow: 1.91 m³/sec (4050 cfm)

Performance Data:

Parameter	Design Computer Data	Off-Design Computer Data	
		Design-Point- Optimized Compressor	Broad Range Compressor
Evaporating temperature, K (F)	280.6 (45)	280.6 (45.1)	280.8 (45.6)
Condensing temperature, K (F)	305.6 (90)	306 (90.8)	305.9 (90.7)
Boiling temperature, K (F)	358.3 (185)	357.5 (183.5)	357.5 (183.5)
Compressor flow, kg/sec (lb/hr)	0.064 (504)	0.064 (504)	0.062 (494)
Turbine flow, kg/sec (lb/hr)	0.075 (592)	0.083 (654)	0.083 (654)
Compressor efficiency, percent	74	71	68
Turbine efficiency, percent	77	80	80
Turbomachine speed, rpm	58,400	58,400	61,320
System capacity, kw (tons)	10.5 (3.0)	10.5 (3.0)	10.3 (2.94)
Power loop efficiency, percent	11	10	10
Refrigeration loop COP	7.1	7.0	6.9
Overall system COP	0.69	0.63	0.61



SECTION 5

PARAMETRIC PERFORMANCE DATA

GENERAL

The parametric performance data presented below are for the unaugmented system operating without auxiliary power solely from the thermal energy contained in the hot water to the boiler. Electrical power will be necessary for the system pumps, fans, and controls. Operation of the system in the augmented mode is discussed in Section 6.

The data were derived with the off-design computer program. The raw data on computer printouts will be furnished to NASA upon request.

RANGE OF INTERFACE PARAMETERS

The performance of the system was predicted over a broad range of interface parameters, including:

- (a) Water temperature at boiler inlet: 344.4 K (160 F) to 383.3 K (230 F)
- (b) Ambient wet bulb temperature: 291.7 K (65 F) to 300 K (80 F)
- (c) Residence wet bulb temperature: 287.8 K (58 F) to 292.8 K (67 F)

The water temperature range covers that anticipated from a reasonable quality flat plate solar collector.

The ambient wet bulb temperature of 300 K (80 F) is representative of the maximum (1 percent time) design point ambient conditions published by ASHRAE for the southeastern region of the United States. The 291.7 K (65 F) ambient wet bulb is also listed by ASHRAE as about a minimum design point condition for arid regions.

The residence wet bulb temperatures selected cover a relative humidity range of 35 to 79 percent at a dry bulb temperature of 75 F. At higher dry bulb temperatures, the relative humidity range would be correspondingly lower. This range spans the largest portion of the classical comfort zone published by ASHRAE.

PARAMETRIC DATA

Baseline system performance is presented in Figures 5-1 through 5-4. Each plot corresponds to a different residence wet bulb temperature. The plots show the variation of system capacity and SCOP plotted as a function of the water temperature at boiler inlet for various values of ambient air wet bulb temperature. Operational limitations imposed by compressor surge and turbomachine overspeed are also shown. Figure 5-5 illustrates the effect of the residence wet bulb temperature.



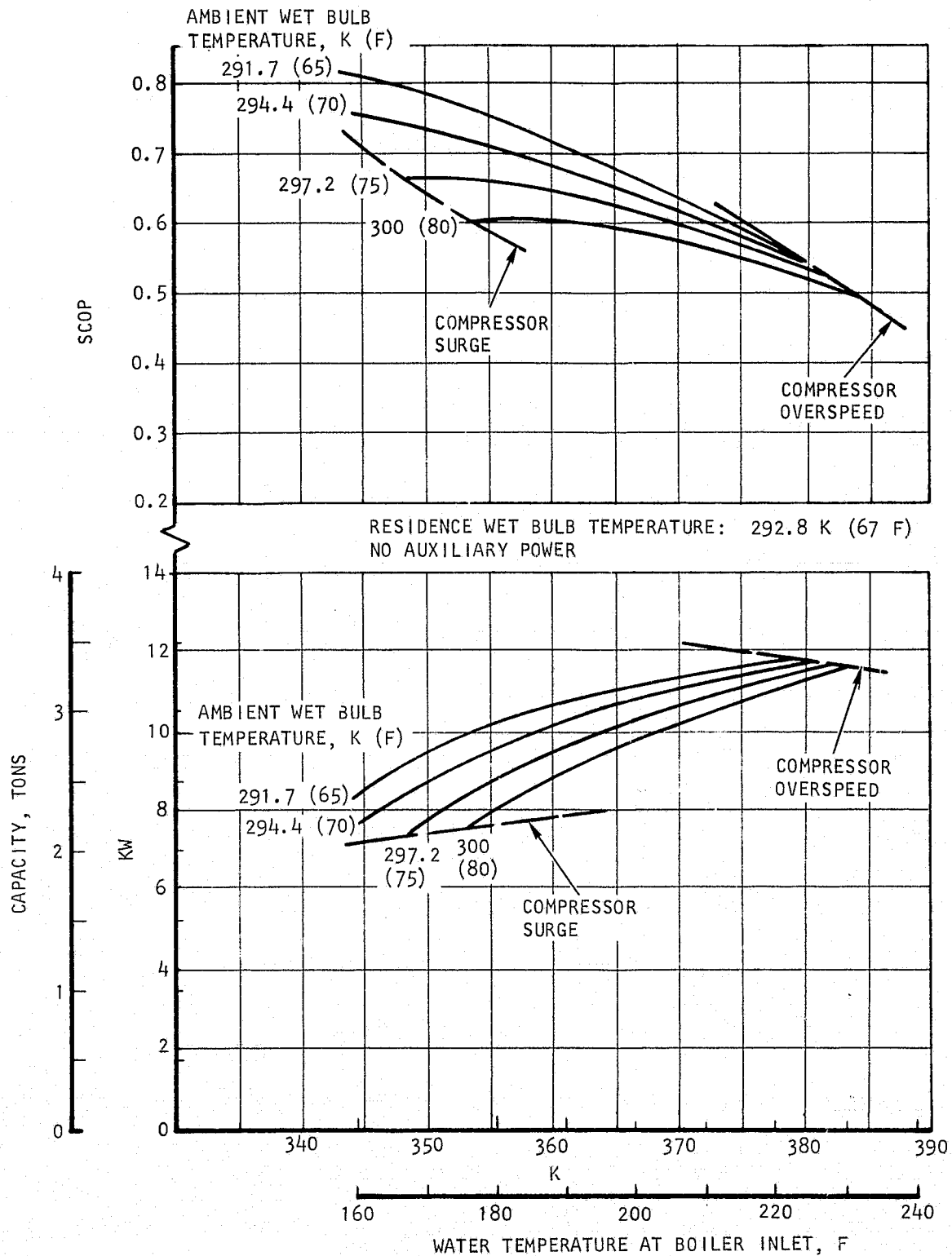

S-200

Figure 5-1. Baseline System Performance (Residence Wet Bulb Temperature = 292.8 K (67 F))



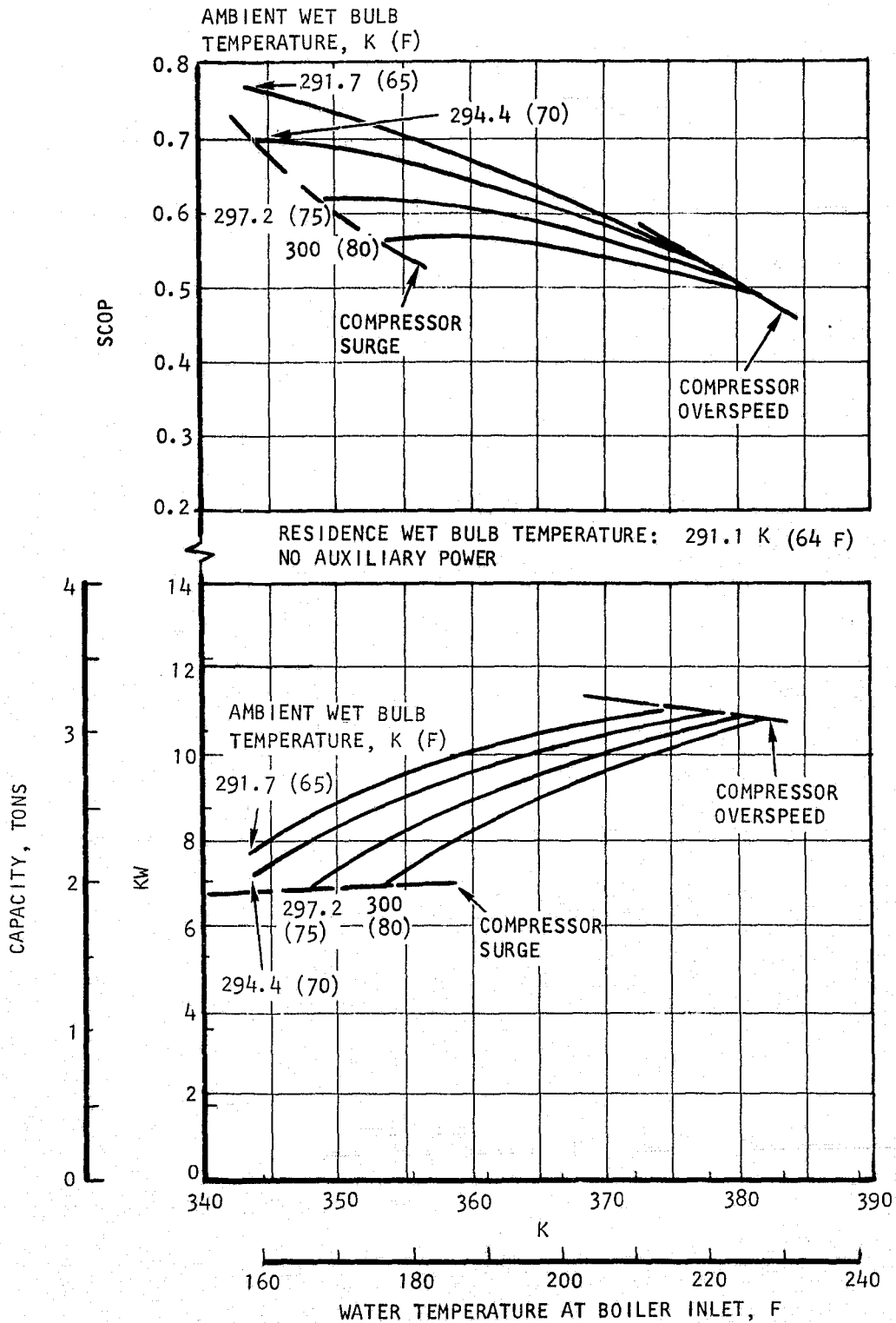

S-199

Figure 5-2. Baseline System Performance (Residence Wet Bulb Temperature = 291.1 K (64 F))



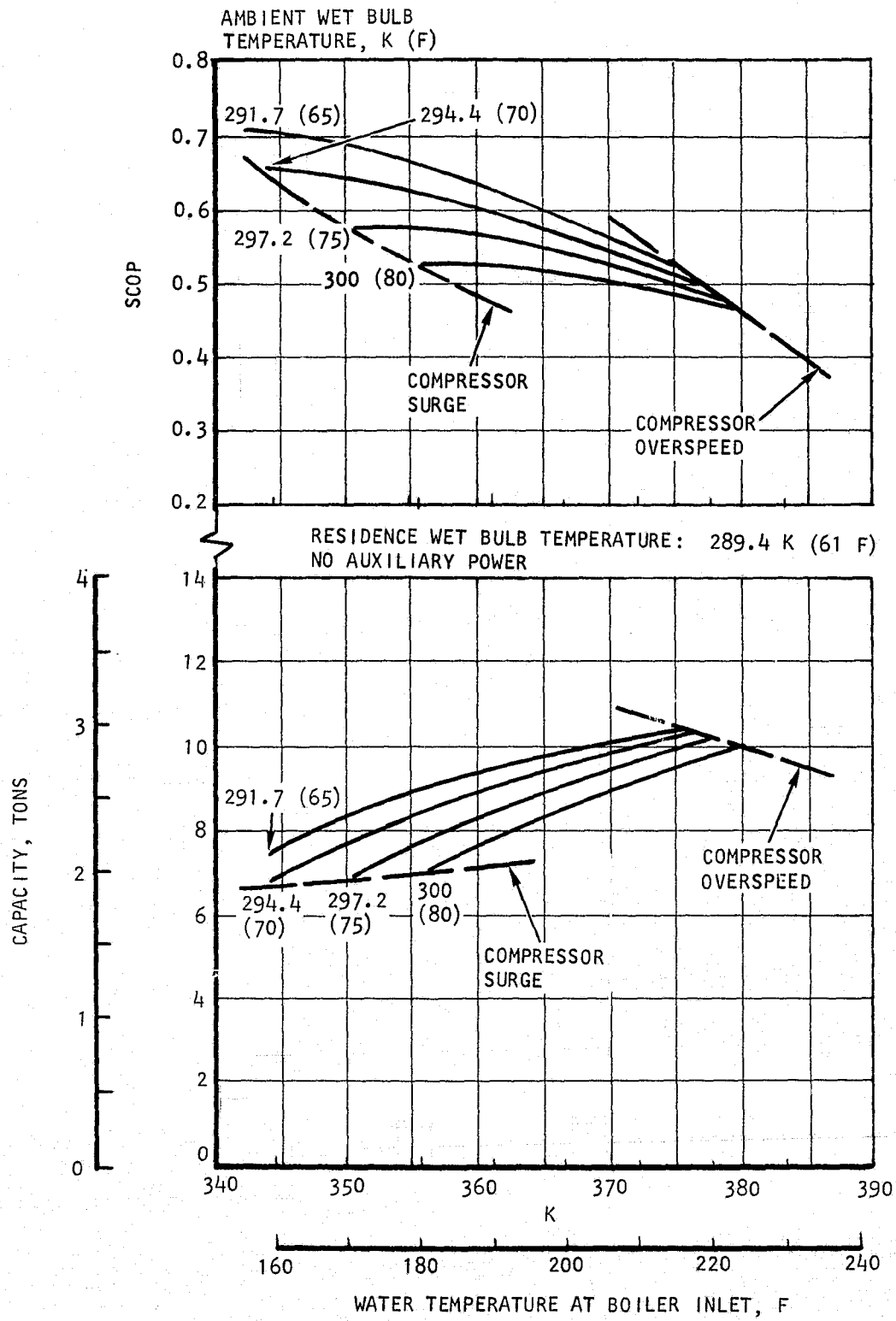

S-198

Figure 5-3. Baseline System Performance (Residence Wet Bulb Temperature = 289.4 K (61 F))

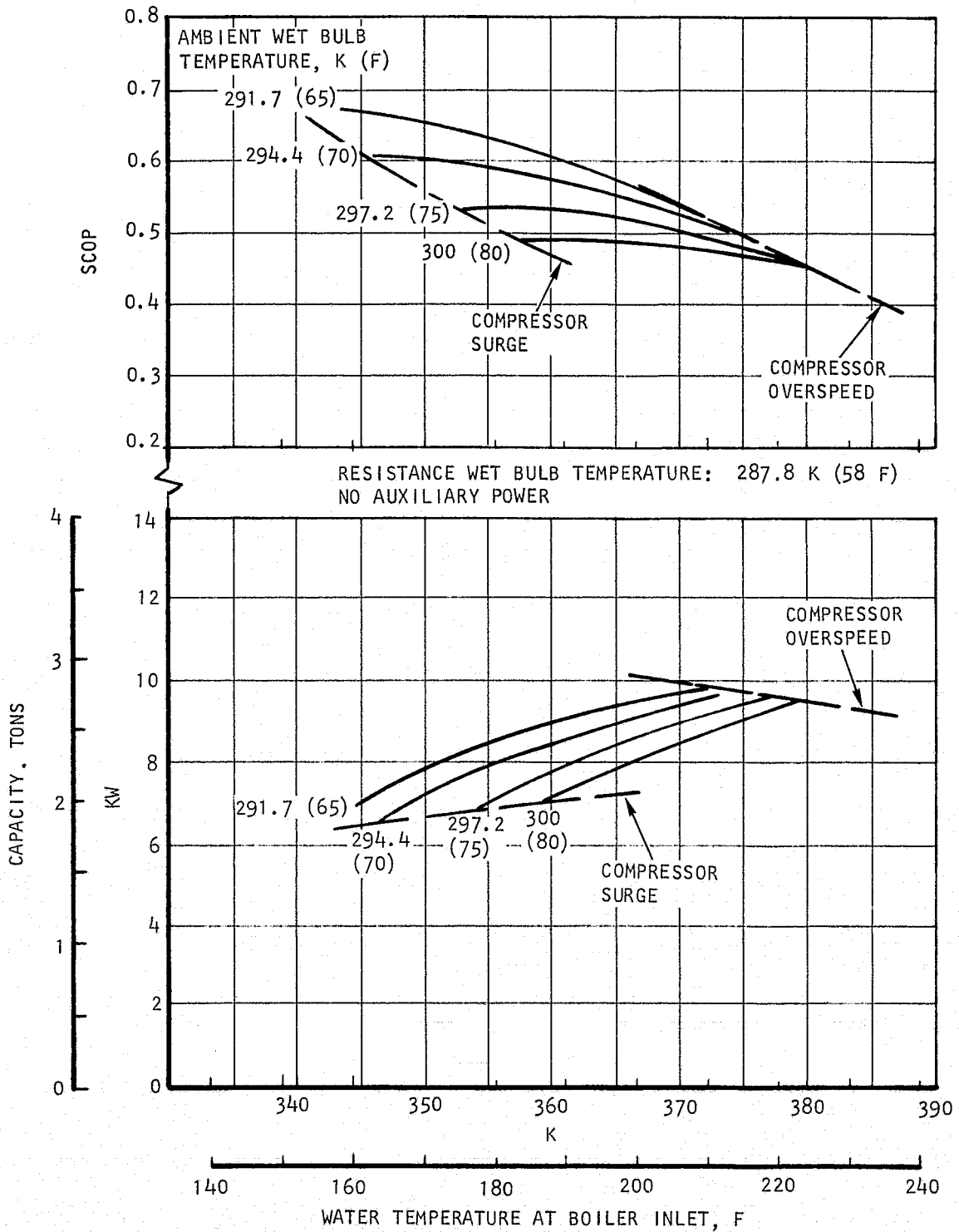

S-197

Figure 5-4. Baseline System Performance (Residence Wet Bulb Temperature = 287.8 K (58 F))



AIRESEARCH MANUFACTURING COMPANY
OF CALIFORNIA

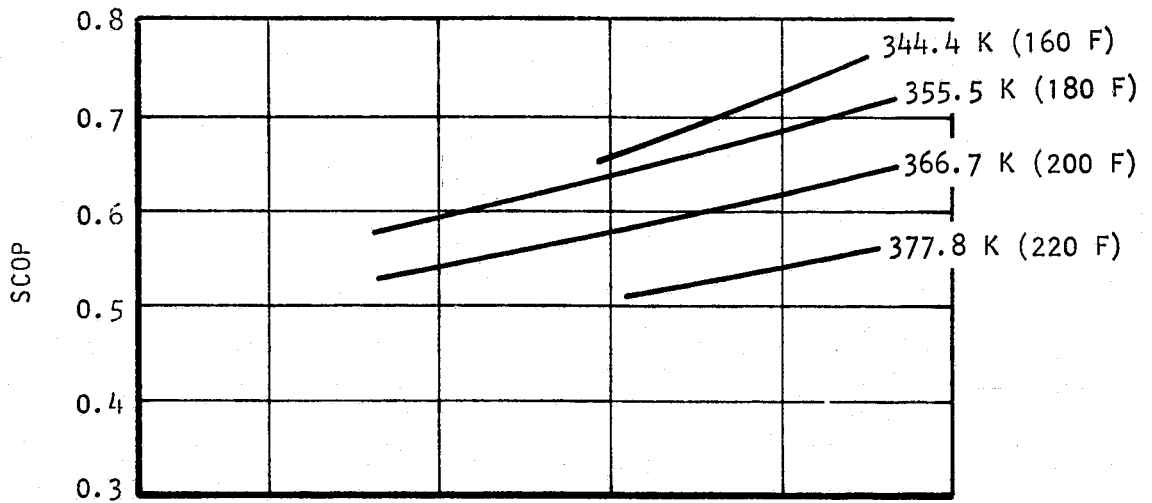

AMBIENT WET BULB TEMPERATURE: 294.4 K (70 F)
 NO AUXILIARY POWER

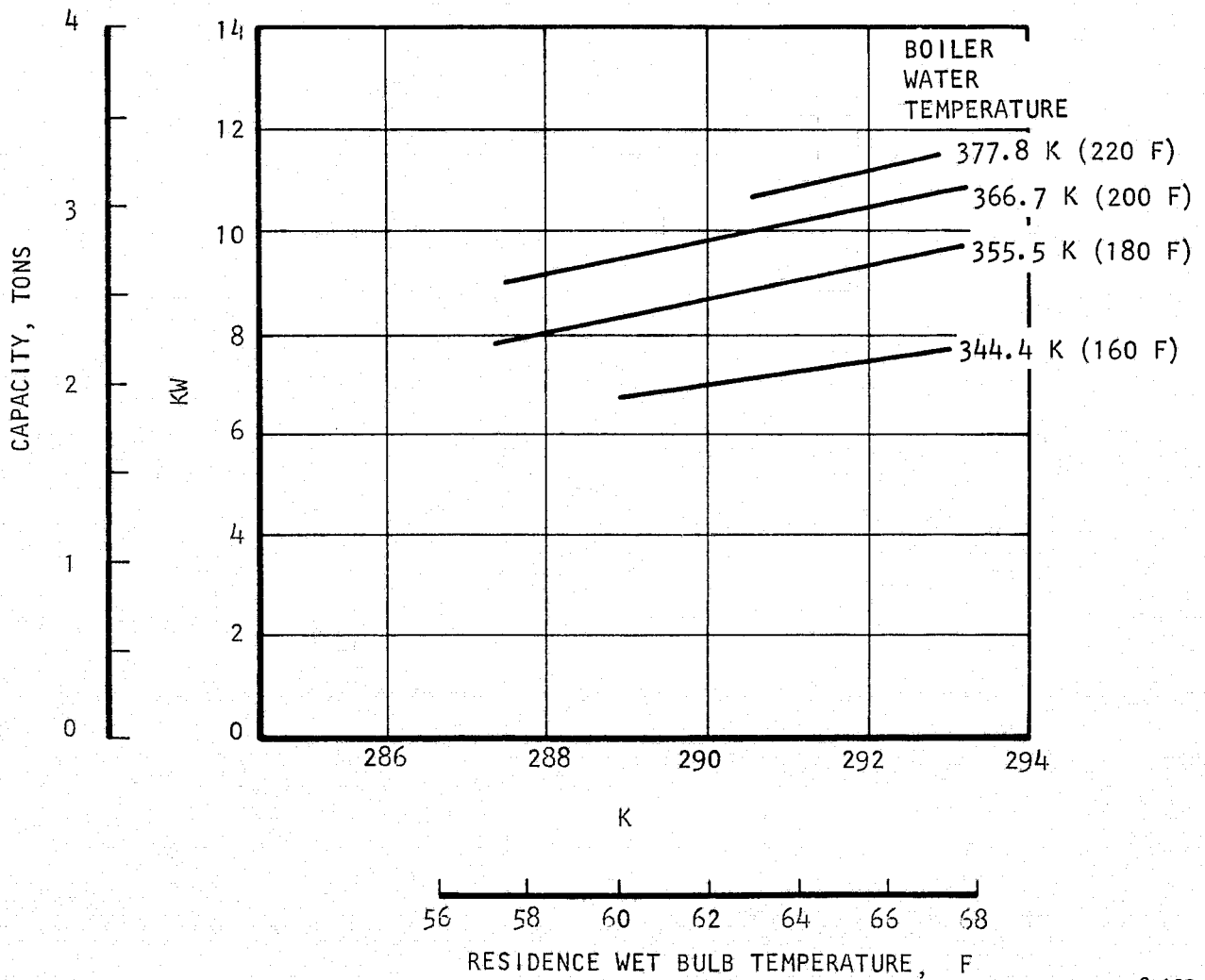

Figure 5-5. Effect of Residence Wet Bulb Temperature



Over the range of interface parameters investigated, system capacity will vary from 7.0 kw (2 tons) to 12.3 kw (3.5 tons). Similarly, the overall SCOP will be 0.5 and 0.8 with the higher SCOP corresponding to lower ambient wet bulb temperature, higher residence wet bulb temperature, and lower boiler water temperature.

The data presented show the following effects of the air conditioner interface parameters:

(a) Higher boiler water temperature will result in

- Higher system capacity
- Lower SCOP

(b) Higher ambient air wet bulb temperature has the following effects:

- Lower system capacity
- Lower SCOP
- Reduced operating range

Conversely, lower residence wet bulb temperature will result in

- Lower system capacity
- Lower SCOP
- Reduced operating range

The higher SCOP's achieved at lower boiler water temperatures are due to (1) higher compressor efficiency, and (2) higher heat exchanger effectiveness because of lower loads. The plot in Figure 5-6 shows turbomachine efficiency and heat exchanger approach temperatures as a function of water temperature for typical operating conditions.

The ambient air wet bulb temperature determines the R-11 condensing pressure. As the ambient wet bulb increases, the system thermodynamic conditions will deteriorate inherently. More power is required from the turbine to match the increasing demand of the compressor. As a result, the capacity and SCOP of the system will drop.

The residence wet bulb temperature has a similar effect on the evaporator. The evaporating temperature of the working fluid drops with the residence wet bulb temperature. Higher compressor lift is necessary to accommodate the lower evaporation pressures. The net effect is as listed above.



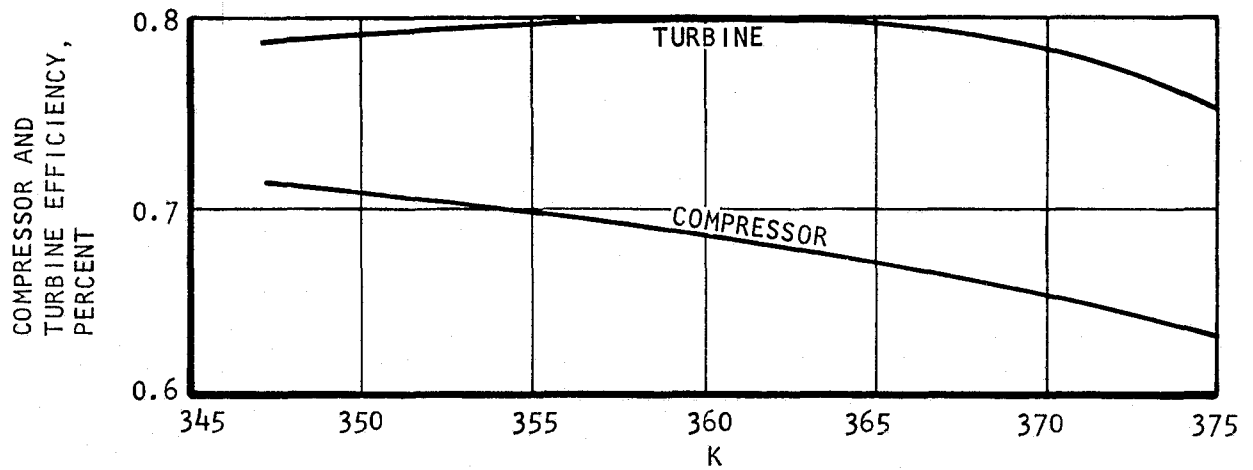

AMBIENT WET BULB TEMPERATURE: 294.4 K (70 F)
 RESIDENCE WET BULB TEMPERATURE: 289.4 K (61 F)

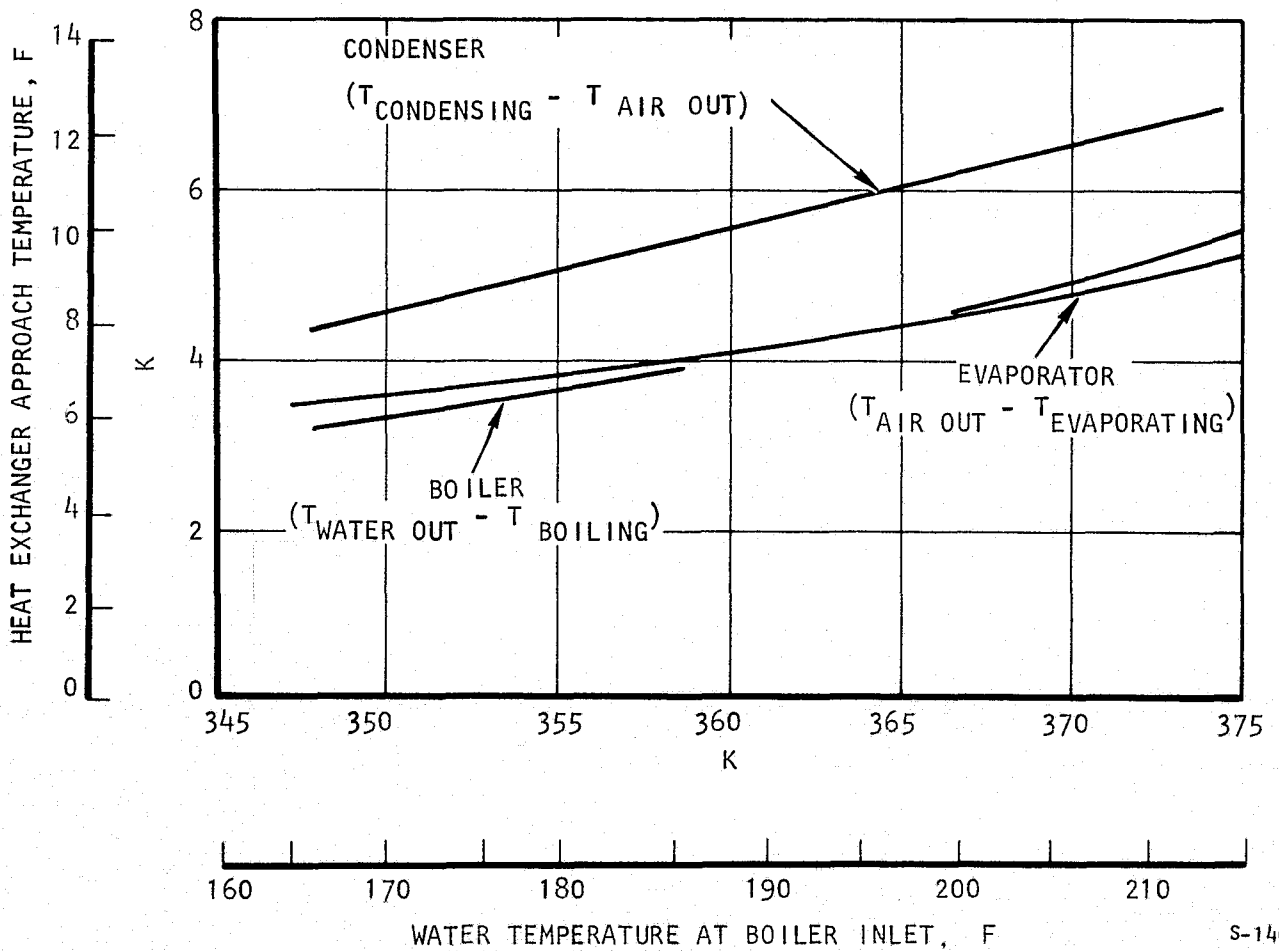

Figure 5-6. Typical Heat Exchanger and Turbomachine Performance



The system is rated at 70.5 kw (3 tons) under standard ARI conditions (ambient dry bulb and wet bulb temperatures: 308.3 K (95 F) and 297.2 K (75 F) respectively; return air db and wb temperatures: 300 K (80 F) and 292.8 K (67 F) respectively). Under less severe conditions (for example, at lower ambient wet bulb temperatures), system capacity will be higher than design. This is illustrated in the plot of Figure 5-1. Conversely, under less favorable conditions the Rankine air conditioner will, like any other system, degrade in performance and capacity. This situation is evidenced by the plots of Figures 5-1 through 5-5, where it can be seen that at ambient wet bulb temperatures higher than the standard ARI value, system capacity and COP deteriorate. This also occurs when the residence wet bulb temperature drops (Figure 5-5).

The operational range of the air conditioner as limited by compressor surge and turbomachine overspeed protection is plotted in Figure 5-7. Typically, with an ambient wet bulb temperature of 244.4 K (70 F), the air conditioner will run without the need for augmentation with water temperatures at boiler inlet from 344.4 K (160 F) to 377.8 K (220 F). This represents a very wide range and is attributed to the flexibility of the turbocompressor to find its own operating speed while maintaining high efficiency.

Over the entire range of conditions investigated, the turbine efficiency was found to vary from 75 to 81 percent. By comparison, the compressor efficiency varied from 55 to 71 percent (Figure 5-8); the lower values occur at high speed corresponding to the upper range of boiler temperatures investigated. This does not appear to be a problem in actual operation since these high temperature levels may never be reached due to solar collector limitations and system heat losses.

Examination of the raw data reveals that the R-11 evaporating temperature will float over a wide range as the operating conditions of the system change. The highest and lowest evaporating temperatures calculated are listed below, together with the interface parameters at which these temperatures will occur.

- Maximum evaporating temperature: 285.5 K (54 F)
Boiler water temperature: 344.4 K (160 F)
Ambient wet bulb temperature: 300 K (80 F)
Residence wet bulb temperature: 292.8 K (67 F)
- Minimum evaporating temperatures: 274.1 K (33.3 F)
Boiler water temperature: 372.2 K (210 F)
Ambient wet bulb temperature: 291.7 K (65 F)
Residence wet bulb temperature: 287.8 K (58 F)

These represent extreme operating conditions. The data reveal that freezing of the evaporator will not occur and that no overriding control will be necessary to maintain the R-11 evaporating pressure above a minimum value.



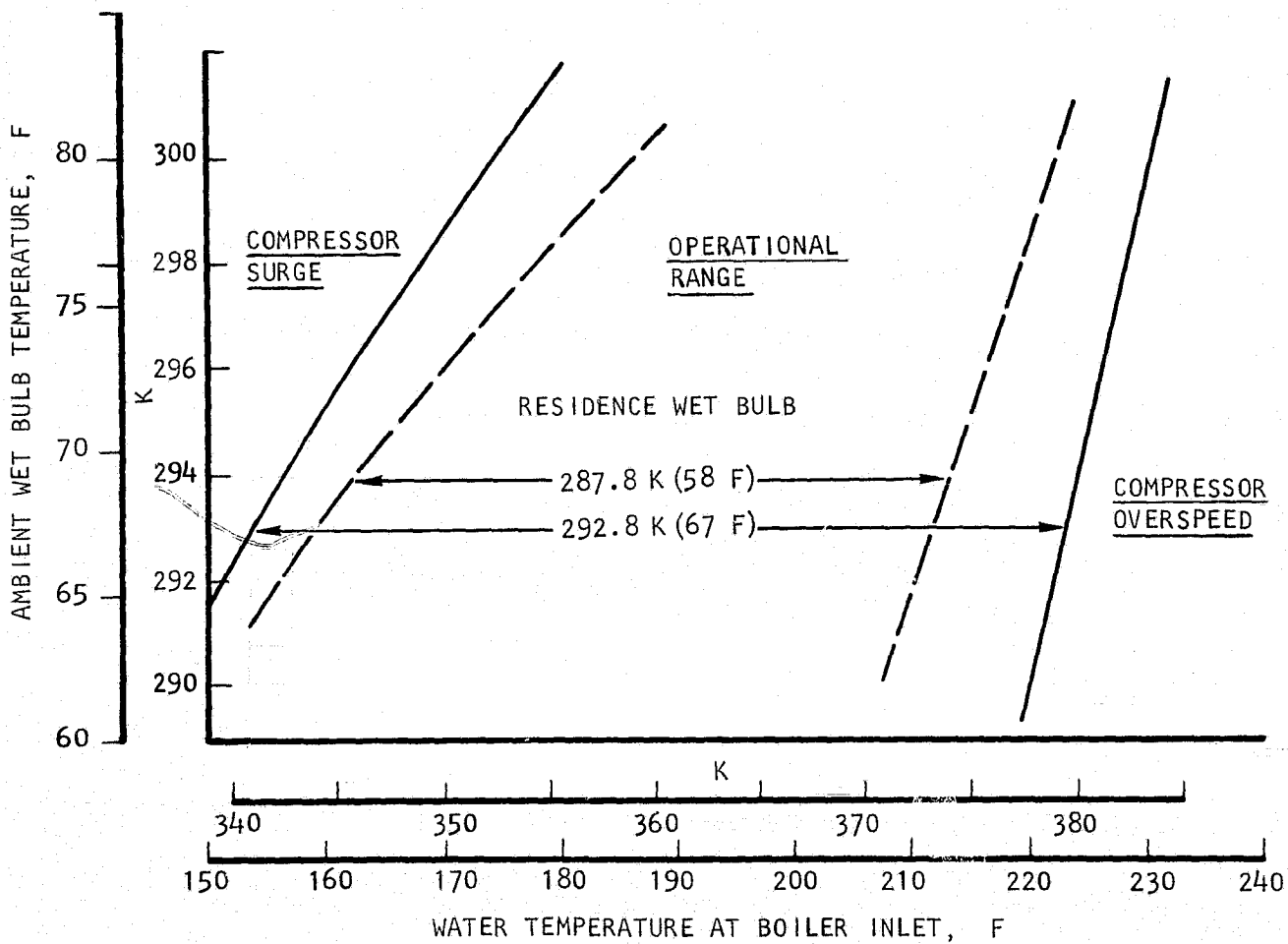

S-146

Figure 5-7. System Operational Range Without Augmentation



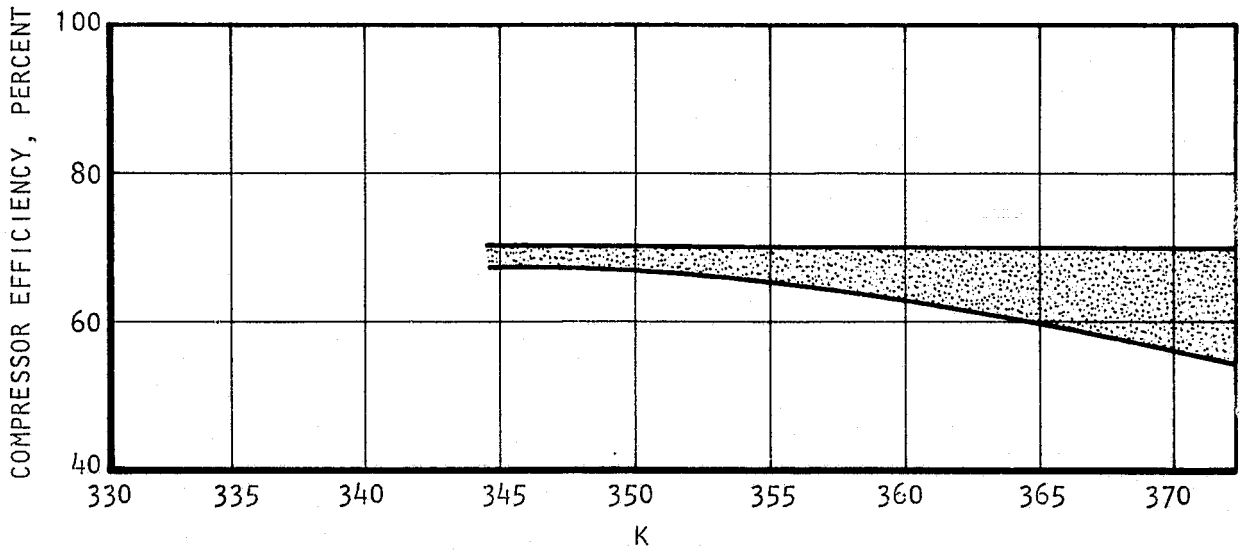

NOTE: NORMAL OPERATION
WITHOUT AUGMENTATION

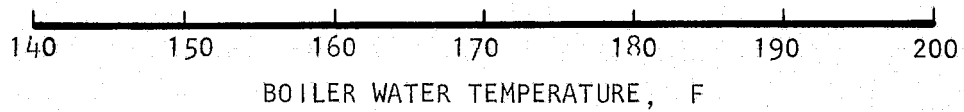
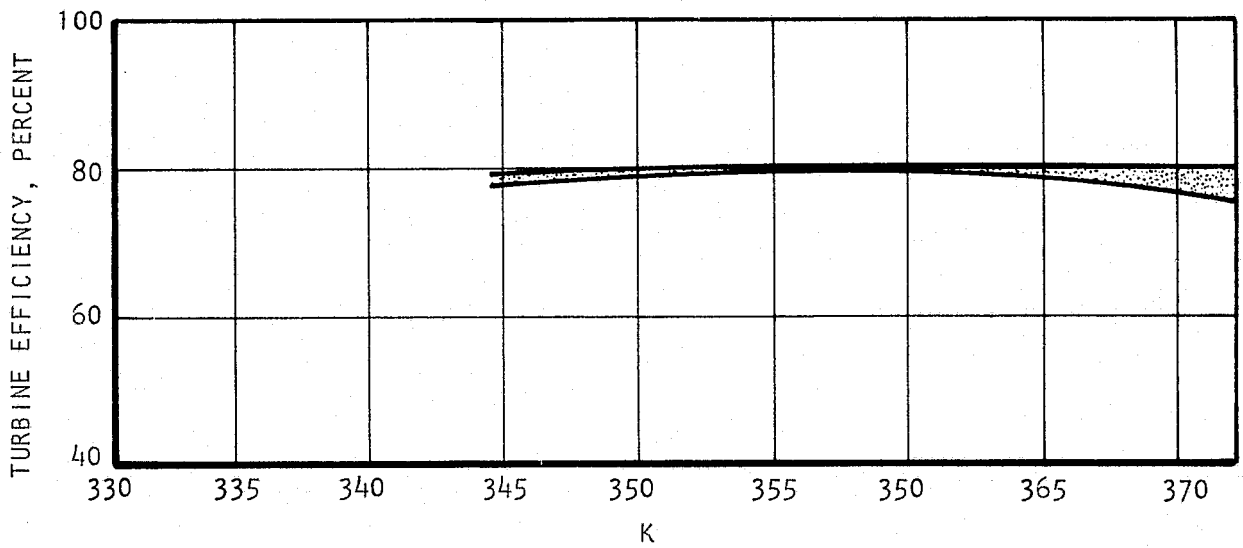

S-142

Figure 5-8. Range of Compressor and Turbine Efficiency



SECTION 6

SYSTEM AUGMENTATION

BASELINE SYSTEM SCHEMATIC

The screening analyses of Task 4 and the system investigations discussed previously have resulted in the development of the baseline system schematic shown in Figure 6-1.

Packaging Considerations

In system packaging, attention should be paid to the relative locations of the various components. The schematic of Figure 6-1 attempts to illustrate the relative positions of the equipment.

The turbocompressor is positioned high in the package to (1) minimize the possibility of liquid refrigerant draining into the compressor and turbine from the condenser lines, (2) minimize entrained liquid refrigerant entering the compressor from the evaporator during startup, and (3) provide adequate line length to ensure vaporization of all liquid refrigerant droplets passing through the superheater section of the boiler. This problem could occur during normal operation, but may be particularly severe during startup. The line from the boiler to the turbine should provide for liquid gravity drain back into the boiler.

The condenser is also located high in the package to provide a maximum hydrostatic head at the evaporator thermal expansion valve and at the inlet to the refrigerant pump. This is particularly important in a system of this type for which the condenser provides only limited subcooling. The refrigerant pump should be installed at the lowest level in the package.

All lines will require insulation to minimize heat losses and obviate undesirable performance shifts during startup. For the same reasons, careful attention will be required to reduce conduction paths from hot components to cold components and also reduce convection and radiation losses to ambient.

Baseline System Control

Control of the baseline system (without provision for augmentation) is necessary for normal operation when the capacity of the system exceeds the demand for cooling. This situation will occur when (1) the house loads are reduced, (2) the boiler temperature is high, (3) the condensing temperature drops, or (4) a combination of the above exists. If the demand exceeds the capacity of the system, then augmentation of the solar thermal energy will be necessary if the house temperature is to be maintained at the selected value. The controls required for operation in this manner will depend on the technique selected for system augmentation. The equipment and controls added to the baseline system for augmentation are described later. The following discussion pertains to the control of the baseline system as depicted in Figure 6-1.





REPRODUCIBILITY OF THIS
ORIGINAL PAGE IS POOR

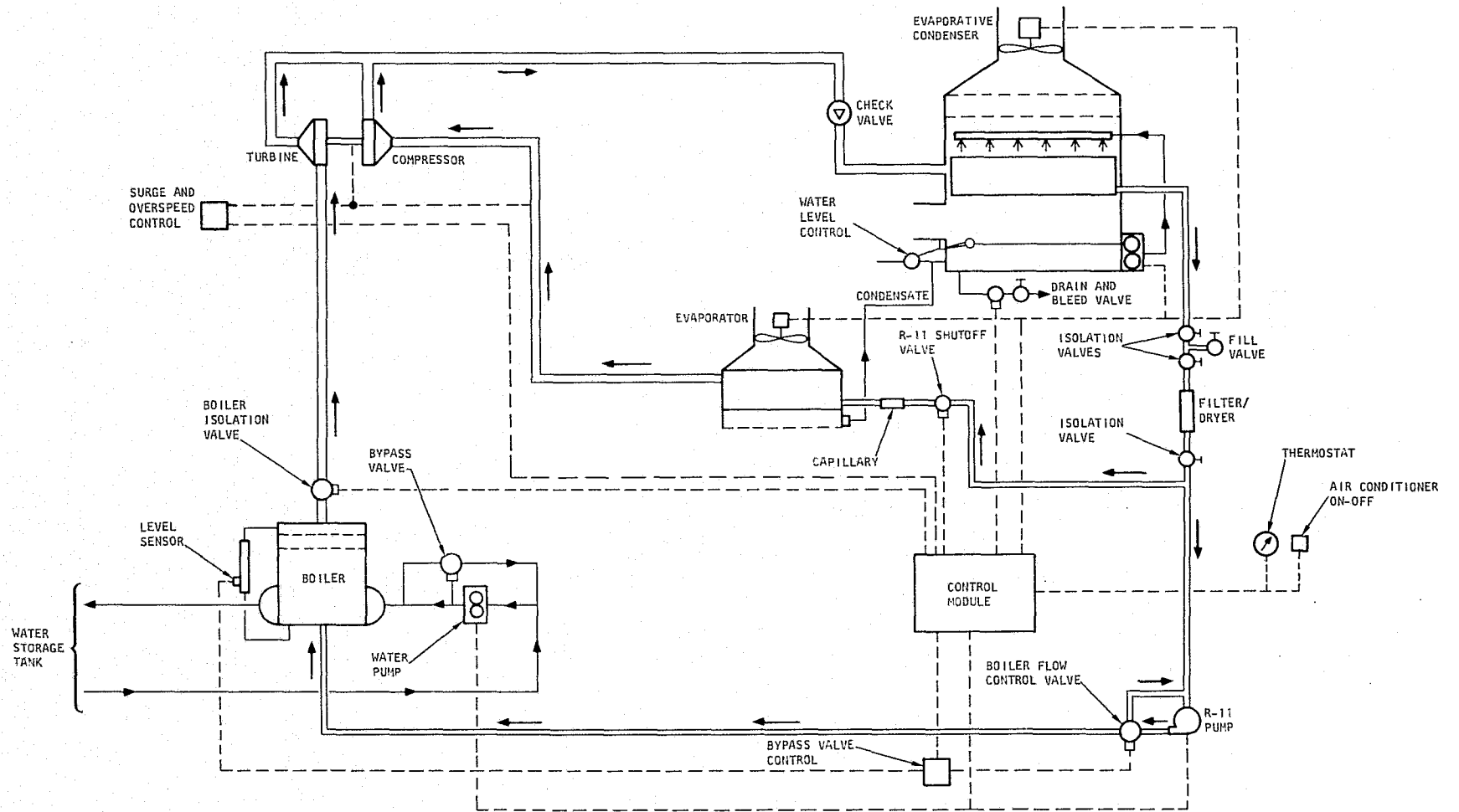

Figure 6-1. Baseline System

Ideally, the baseline control system should provide the following features:

- (a) Optimum utilization of solar thermal energy
- (b) System operation without augmentation at minimum water temperature to the boiler
- (c) Minimum requirement for auxiliary power
- (d) Minimum use of parasitic power for fans, pumps, and controls
- (e) Minimum transient effects

Two types of control schemes were considered for the baseline system: (1) a modulating control that matches system capacity to the demand, and (2) an on-off control with which the system is operated at the full capacity attainable under given conditions; since this capacity exceeds the demand, the system will automatically shut off when the demand is satisfied and will start again as required by the residence thermal transients.

A modulating control would use the difference between the residence temperature and the thermostat setting (demand), and the difference between the residence temperature and the cool air temperature from the evaporator (capacity). Anticipator or duty cycle circuitry may be necessary to ensure stability and proper control functions. Using the signals generated, a number of parameters can be controlled to modulate system capacity. A brief discussion of the alternatives considered follows.

Hot Water Flow to Boiler--A reduction in the hot water flow to the boiler will result in a drop in R-11 flow rate to the turbine and also in a reduction in pressure available at the turbine. As a result, compressor speed will drop corresponding to an increase in evaporator temperature (assuming constant condenser temperature). The net effects will be a loss of potential for latent heat removal and lower power loop efficiency, resulting in lower overall COP and inefficient utilization of stored thermal energy.

Control of Turbine Inlet Pressure--A flow control valve could be used to control turbine inlet pressure with the same effects as for control of hot water flow to the boiler.

Control of Condenser Airflow--Condenser airflow can be controlled by flow control vanes or by means of a variable (or two-speed) fan. In either case, condenser temperature will increase. Data presented earlier (AiResearch report 74-10996(7)) show that this will result in significant performance deterioration. This approach also is wasteful of stored water energy.

Control of Liquid Refrigerant Flow to the Evaporator--A reduction in evaporator flow will result in an increase in the compressor speed and pressure ratio. Assuming constant condenser temperature, this results in a lower refrigeration loop COP with the same overall effect as for the three previous cases.



Other means of capacity control such as evaporator pressure control, compressor bypass, or compressor discharge pressure control have the same degrading effects on system COP and utilization of solar energy. In addition, a modulating type control will increase the duty cycle of the system fans and pumps and the parasitic electrical energy necessary for system operation. Although it minimizes transient effects, a modulating type system is not recommended.

The baseline system control is shown in Figure 6-1. A thermostat is provided at a suitable location in the residence, together with an on-off switch. When the air conditioner is switched on, the control module assumes control for automatic cycling of the system from the thermostat upper and lower set point temperatures. In addition, the ON switch activates the evaporative condenser water pump and opens the condenser sump solenoid bleed valve.

When the residence temperature exceeds the upper thermostat set point, the evaporator and condenser fan and the R-11 boiler feed pump are activated. At the same time, the boiler isolation and evaporator shutoff valves are opened. As the system operates, the residence temperature will drop until the thermostat lower set point is reached. Then the control module will deactivate the fans, refrigerant pump, and solenoid valves, and the system will assume a standby status.

With the evaporator shutoff valve opened, the flow of refrigerant to the evaporator is controlled by a capillary tube.

The water level in the sump of the evaporative condenser is controlled between fixed limits by a float-actuated water shutoff valve. A fixed bleed is provided to prevent salt accumulation; the rate of bleed can be adjusted manually depending on the local water salt content. Water recirculation will be maintained during standby conditions to prevent periodic drying of the water on the surface of the evaporator tubes and to obviate salt deposition and corrosion. In addition, the water flow in the condenser tubes will prevent heating of the condenser during standby and keep the condenser near its operating temperature. This will provide a significant advantage toward the elimination of startup transients. A check valve in the vapor line to the condenser, together with the refrigerant shutoff valve at the evaporator inlet, will prevent refrigerant transfer to the evaporator during standby and shutdown. Subcooled conditions will be preserved in the condenser lower tubes, and a positive head will be available for refrigerant pump startup.

A level sensor is provided on the boiler to control a pump bypass valve and thus adjust the refrigerant flow to match the boiling rate. An isolation valve in the vapor line from the turbine is opened during operation. This valve will be closed when the system is on standby to prevent refrigerant migration to the evaporator or condenser. This will prevent flooding of these two heat exchangers and also maintain the boiler at pressure and temperature. Depending on the duration of the off cycles and the thermal losses from the boiler, it may be necessary to provide a continuous reduced flow of hot water through the boiler to offset the effects of heat losses and valve leakage during standby. In this manner, the boiler will be maintained at high pressure, and startup transients will be minimized.



Turbocompressor speed is controlled below a maximum value (76,000 rpm) consistent with the aerodynamic and structural characteristics of the turbine and the compressor by monitoring the temperature of the hot water to the boiler. A bypass valve limits heat input to the system below a safe value compatible with maximum turbomachine speed. Compressor surge is obviated by monitoring speed and inlet flow rate. Should compressor operating conditions be such that they approach the surge line, a signal will be provided to the control module for augmentation.

SYSTEM AUGMENTATION CONCEPTS

The baseline Rankine system just discussed must be further developed to include means of supplementing the solar thermal energy source when necessary. Three approaches were considered, evaluated, and compared using the off-design computer program:

- (a) Thermal energy input into the water loop to the boiler. As an alternate, an electrical heater could be packaged within the boiler itself.
- (b) Auxiliary reciprocating compressor installed in parallel with the system turbomachine which assumes the load when (1) the Rankine system capacity drops below the demand, or (2) unassisted operation is impossible due to compressor surge.
- (c) Electric motor drive integral with the turbocompressor to supplement turbine power and maintain compressor speed at the desired level.

Operation and control of these systems in the augmented mode are described in the following paragraphs.

For proper operation of the augmented system, the control module must have sufficient information to (1) determine when to turn the auxiliary power on and off, and (2) control system functions in the augmented mode. A tradeoff must be made between economy of operation and system performance; a compromise solution must be reached which should be resolved by the owner of the system. To this end, provisions should be made in the control system for adjustment of the auxiliary activation set point. A warning light should be installed near the thermostat to indicate when auxiliary power is used. Further means for overriding the automatic mode of operation in the ON or OFF positions should be provided. Such a control is desirable for maximum economy or for system capacity enhancement to meet maximum demand situations which could occur during initial residence cooldown or in extreme climatic conditions.

Should system capacity deteriorate due to a drop in water temperature at the boiler inlet or increase in condensing temperature, the compressor speed and flow will drop significantly. Operation at reduced capacity may be adequate to maintain the residence temperature within the thermostat set points; however, if, for example, the residence temperature increases 1.1 K (2 F) (adjustable) above the set point, then the auxiliary could be automatically switched on to obtain maximum system capacity. The intelligence used by the control module



is available from the baseline system instrumentation: thermostat set points and turbine pressure ratio.

To obviate situations where continuous operation in the augmented mode does not generate sufficient capacity to reduce the residence temperature below the lower thermostat set point, a storage water tank temperature sensor may be desirable. The signal from this sensor would allow activation of the auxiliary only when the water temperature is below a certain value, e.g., 366.4 K (200 F). This signal could also be used to switch off the auxiliary when tank water temperature increases. This will minimize auxiliary energy usage. The auxiliary power and the entire system are switched off when the residence temperature reaches the lower thermostat set point, and the air conditioner control will be reset for baseline operation without the auxiliary power.

Concept A, Auxiliary Thermal Energy (Figure 6-2)

Gas, fuel oil, or an electrical heater could be used in a water heater at the boiler inlet to provide a boiling temperature commensurate with operation of the system at maximum capacity. Switchover to auxiliary power will occur as previously described. This will involve opening the water diverter valve around the boiler and the gas or oil supply valve (alternately, the electrical heater will be powered).

1. Capacity Enhancement by Auxiliary Heater

With this method of augmentation, it appears extremely wasteful of energy to activate the auxiliary heater only to enhance system capacity since in the augmented mode all thermal energy necessary for operation is from the auxiliary heater. Figure 6-3 illustrates this fact. The plot was prepared for typical operating conditions of ambient and residence wet bulb temperatures. It shows the power penalty paid in terms of kw per unit of increased capacity over a range of boiler water temperatures. At water boiler temperatures below 343 K (158 F), the system compressor will surge and system operation in the normal mode is impossible. Auxiliary power will be necessary at the rate of 17 kw to maintain the water temperature at boiler inlet at 366.7 K (200 F). Under these conditions, system capacity will be 9.9 kw (2.9 tons).

System operation at reduced capacity is possible with water temperatures as low as about 344.4 K (160 F). Under these conditions, system capacity will be 7.2 kw (2.1 tons). Should an increase in capacity be desired, the auxiliary heater could be switched on manually and the air conditioning rate could be increased to 9.9 kw (2.9 tons). The power input to the water will then be 17 kw as mentioned above. This power is expended only to enhance the capacity of the system from 7.2 to 9.9 kw (2.1 to 2.9 tons), so the penalty paid is 6.24 kw/kw (21.3 kw/ton) of added capacity. As the temperature of the water from the thermal storage unit increases, this penalty increases since the capacity in the normal mode of operation also increases; the plot in Figure 6-3 shows this effect. Auxiliary heater use for capacity increase is therefore not recommended. The signal used by the system for activating the auxiliary heater should be the compressor surge sensor.



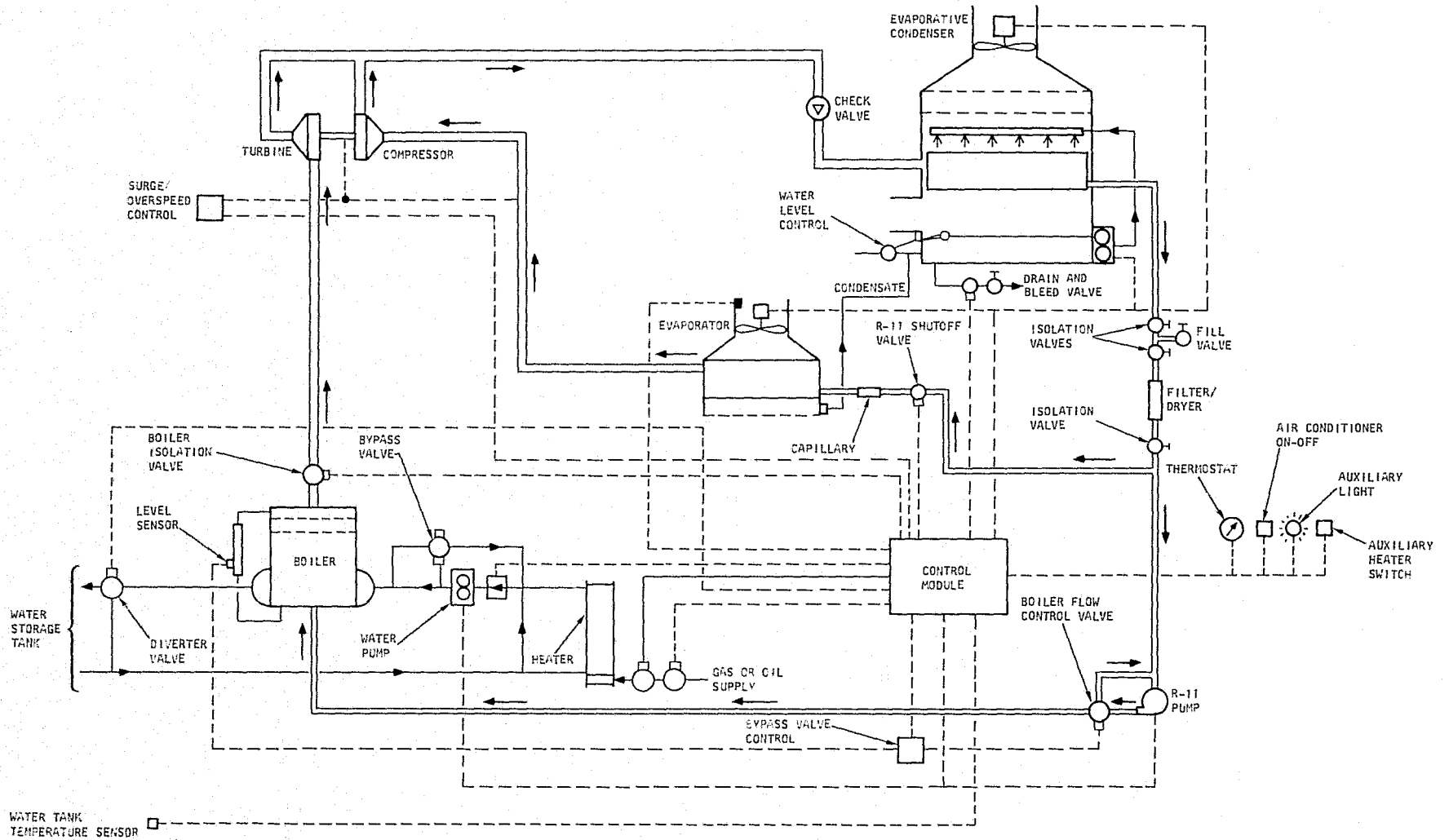
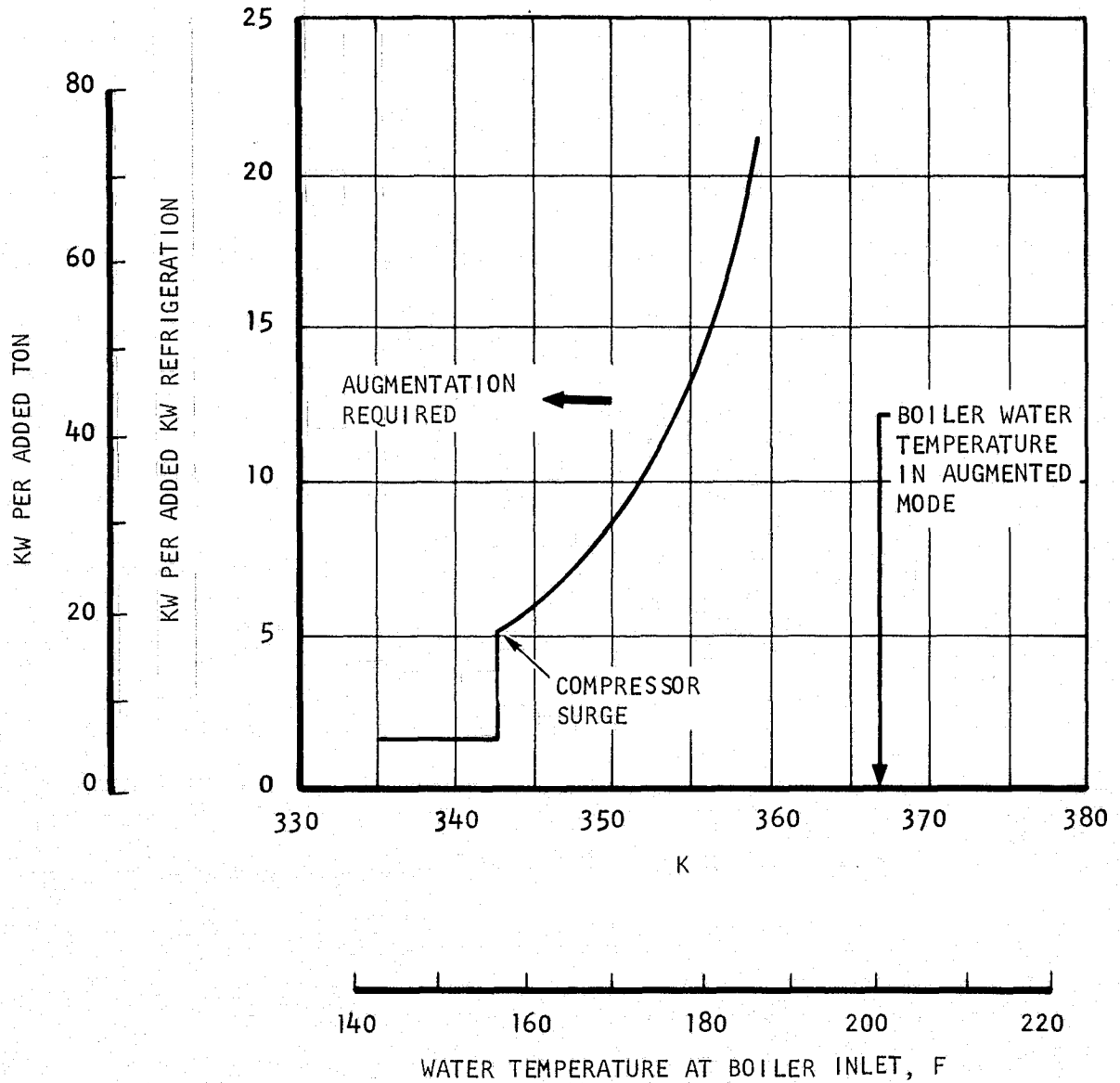

Figure 6-2. Concept A, Auxiliary Thermal Energy

- AMBIENT WET BULB TEMPERATURE: 294.4 K (70 F)
- RESIDENCE WET BULB TEMPERATURE: 291.1 K (64 F)
- AUXILIARY HEATER EFFECTIVENESS: 100 PERCENT



S-315

Figure 6-3. Penalty for Capacity Increase with Auxiliary Heater



2. Power Requirement for Augmentation

The power necessary for system augmentation was taken as constant to obviate the requirements for monitoring and control. Here, a simple on-off control will be adequate. Over the entire range of operating conditions, a 17-kw electrical heater will maintain water temperature at boiler inlet near 366.7 K (200 F). If a gas- or oil-fired heater is used, the system energy requirement should account for the inefficiency of the heater itself. This could be as high as 80 percent through careful design.

The system capacity in the augmented mode is shown in Figure 6-4. Overall system electrical energy requirement (EER) is shown in Figure 6-5. System EER includes the parasitic power necessary to drive the fans, pumps, and controls and represents the overall COP of the machine in terms of electrical power input.

The power level necessary for operation in the augmented mode far exceeds the power requirements of conventional air conditioners. Commercial units currently marketed have an overall COP (including power for fans and controls) as high as 2.7. This compares to a COP between 0.4 and 0.6 for the Rankine system in the augmented mode with auxiliary heaters.

Concept B, Auxiliary Compressor (Figure 6-6)

The requirement for auxiliary power is established through monitoring of the parameters described previously. In this case, the Rankine power loop is turned off. This involves stopping the hot water and R-11 pumps and also closing the boiler isolation valve. The entire load is then carried by the auxiliary compressor. The check valve at condenser outlet prevents refrigerant recirculation around the compressor. A back pressure control limits evaporation pressure and prevents freezing at the evaporator.

Estimates were made of the auxiliary power necessary in the augmented mode of operation. The compressor efficiency in Figure 6-7 was used for this purpose. The design point was selected to give a 10.5-kw (3-ton) capacity at ARI standard rating conditions. At that point, the isentropic efficiency of the compressor is 80 percent. The motor efficiency was assumed at 70 percent over the entire range of operation.

Auxiliary compressor power is shown in Figure 6-8, plotted as a function of ambient and residence wet bulb temperatures. In the range of conditions considered, the auxiliary compressor will require between 1.1 and 1.7 kw of input power. System capacity, also shown in Figure 6-8, is between 7.0 and 10.5 kw (2 and 3 tons).

Compressor power requirement is only about 10 percent of that required with the auxiliary heater. With the auxiliary compressor, energy is added to the compressor at an efficiency of about 70 percent. In the case of the auxiliary heater, the energy input is used in a low temperature-low efficiency Rankine loop (on the order of 10 percent).



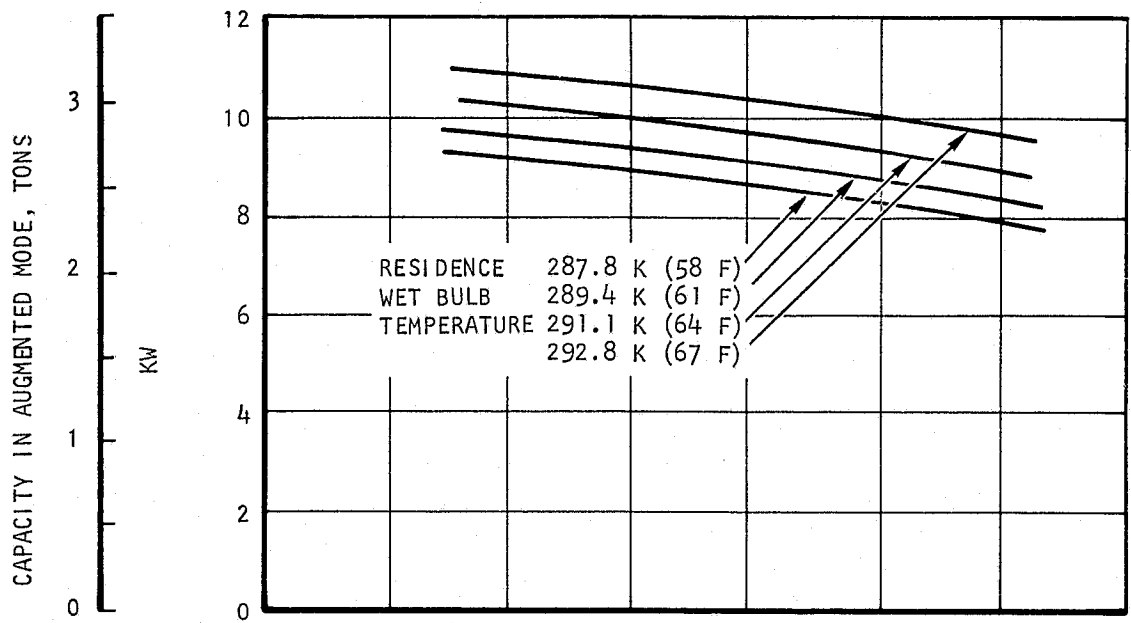

Figure 6-4. System Capacity in the Augmented Mode (Auxiliary Heater)

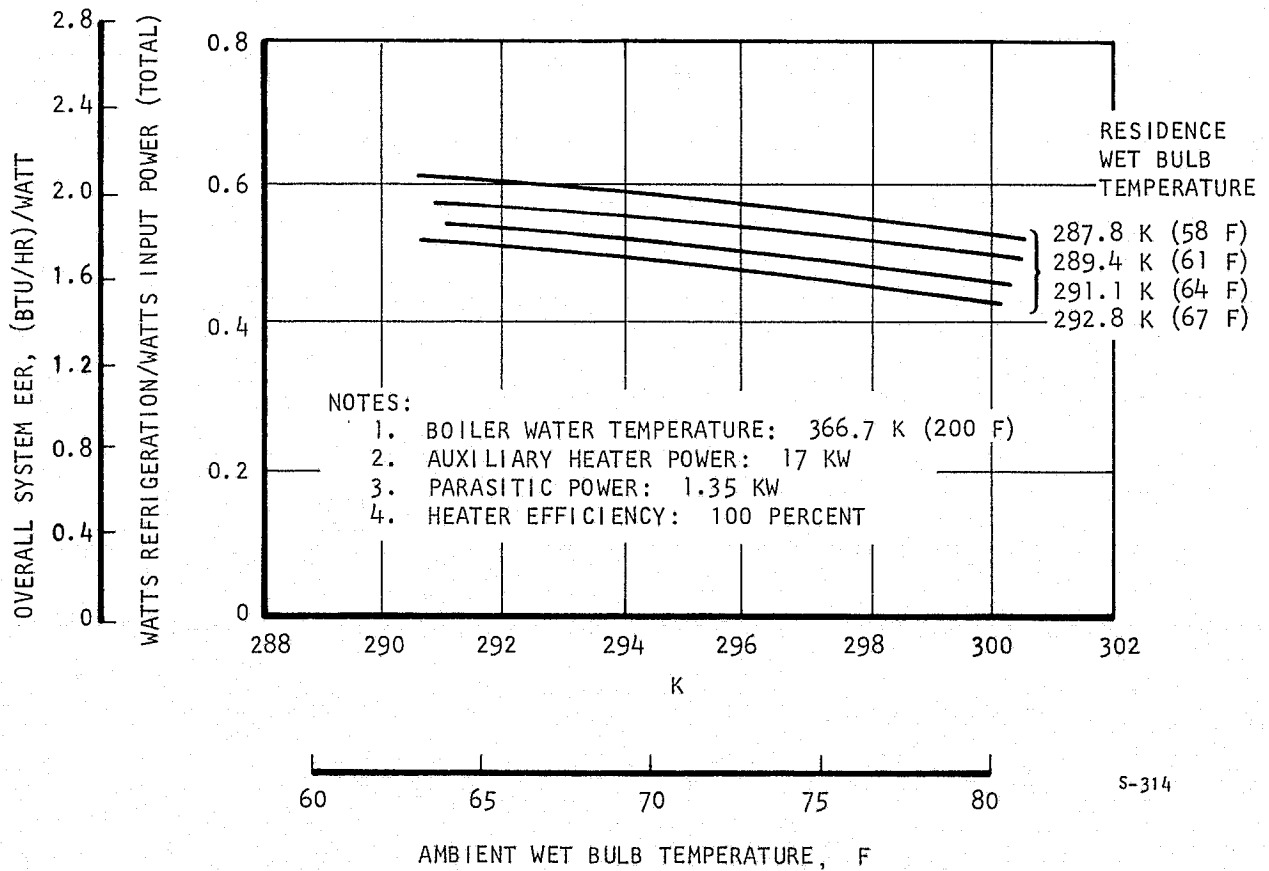

Figure 6-5. System EER with Auxiliary Heater

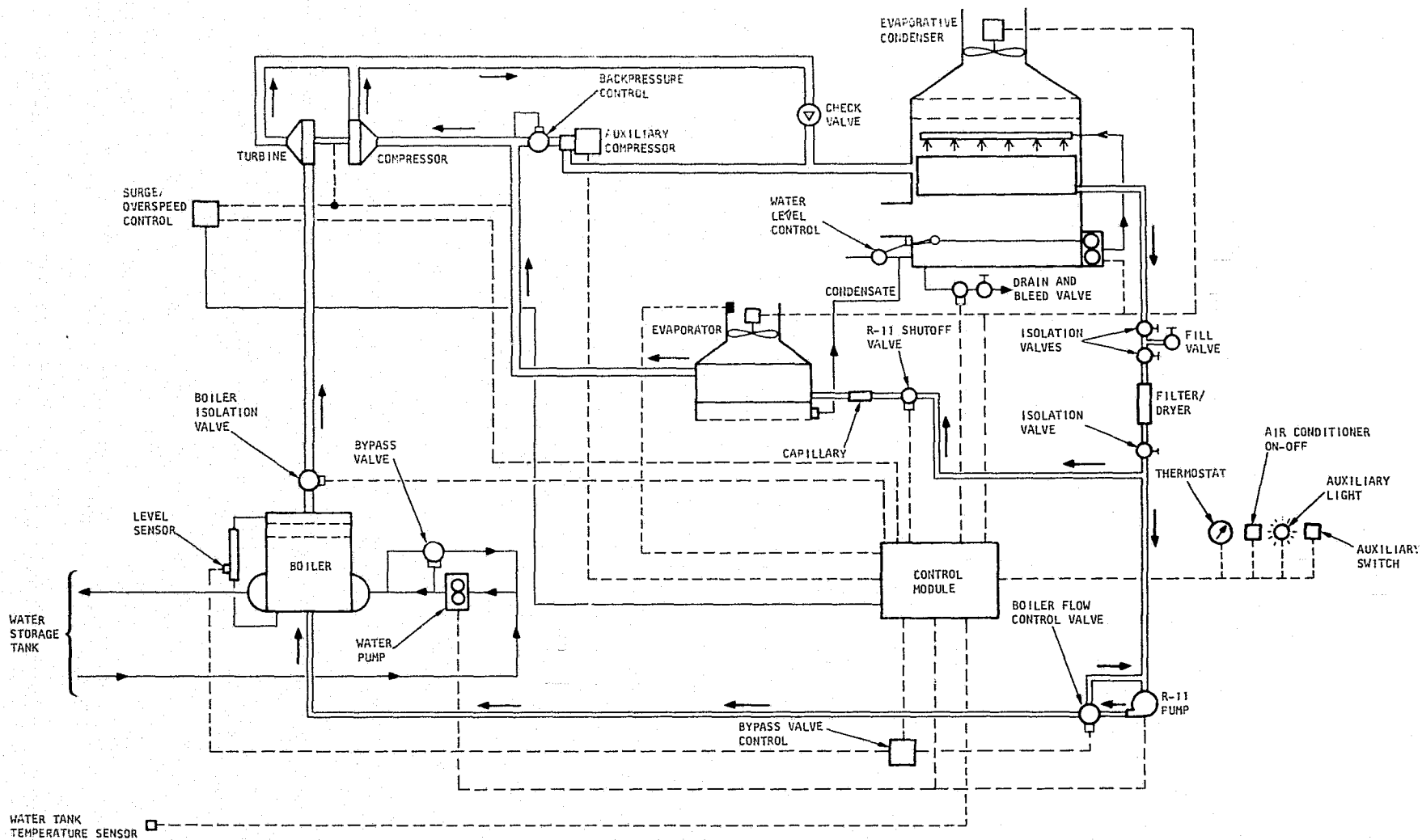
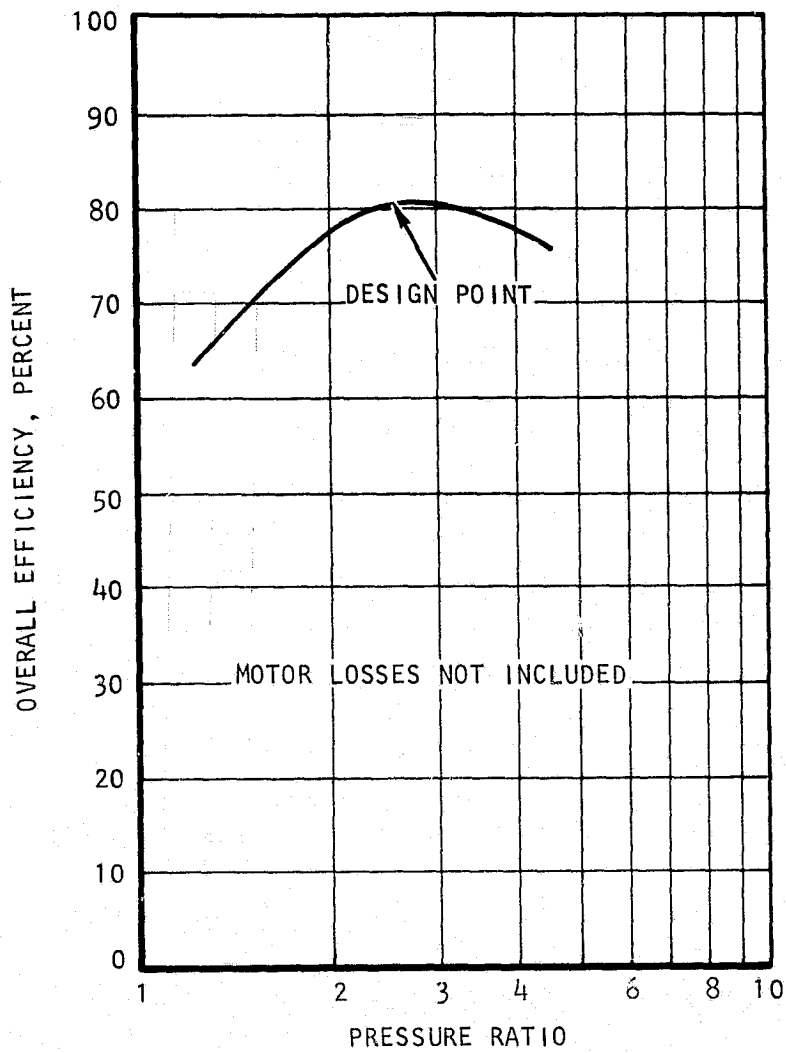

Figure 6-6. Concept B, Auxiliary Compressor



S-141

Figure 6-7. Typical Constant Displacement Compressor Isentropic Efficiency



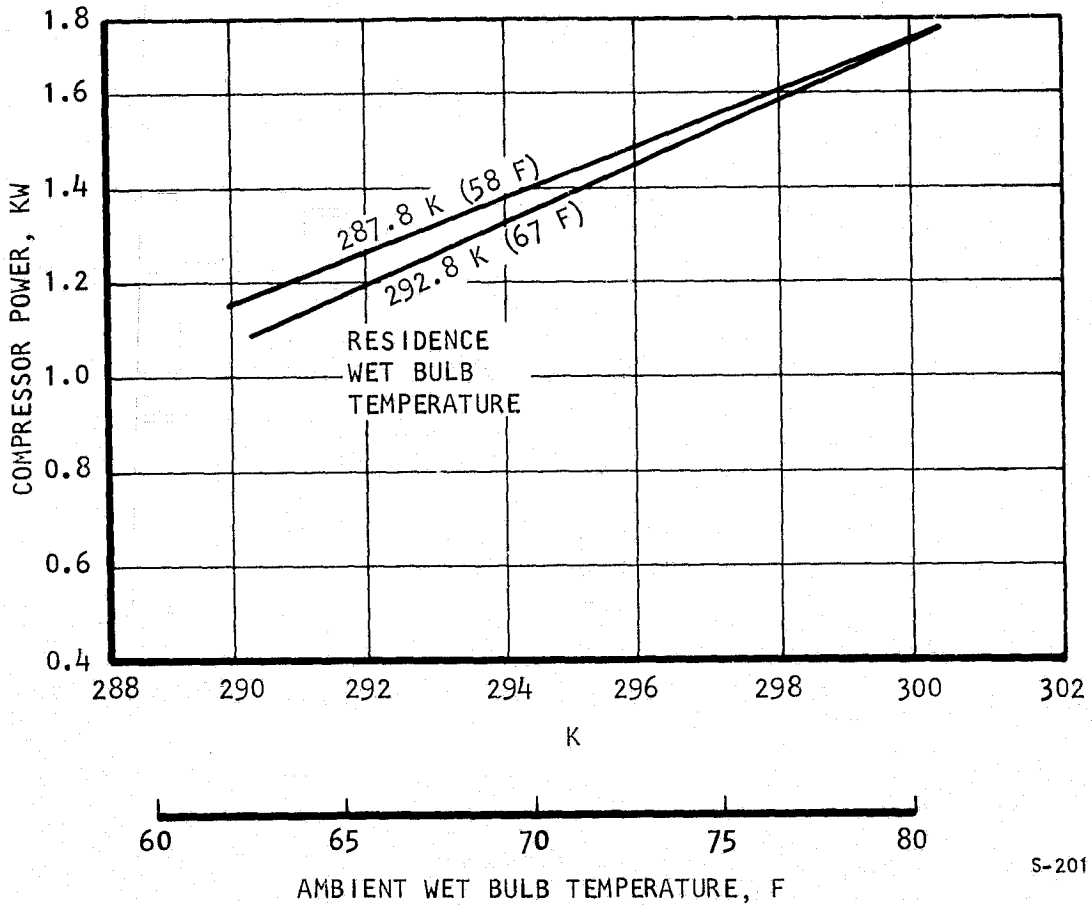
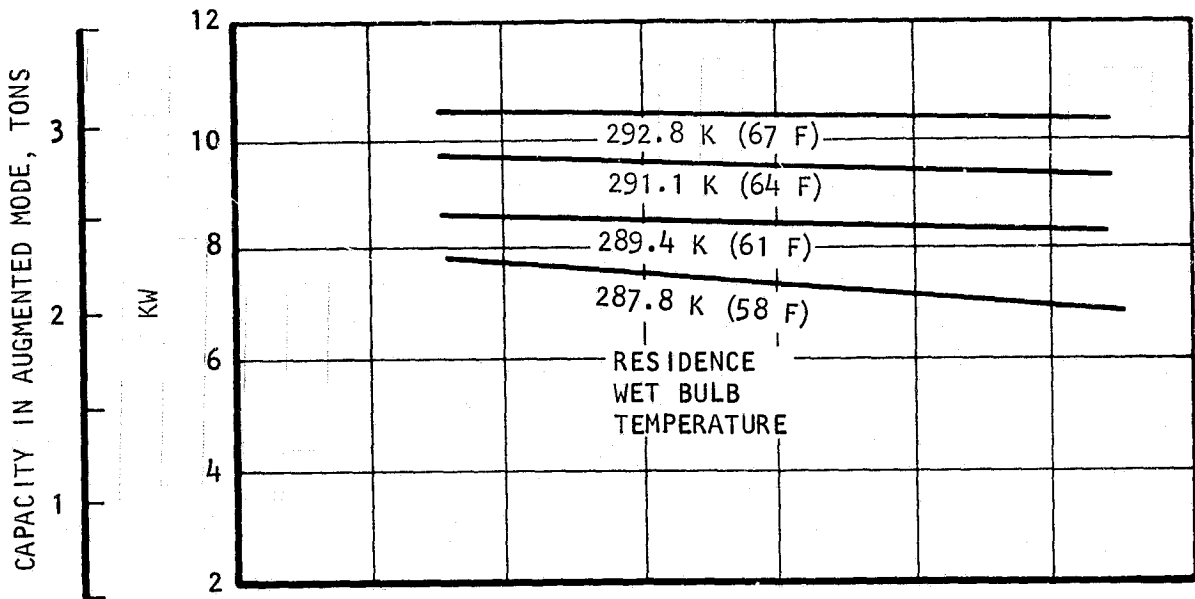

Figure 6-8. Auxiliary Compressor Power and System Capacity



The system electrical energy requirement (EER) is plotted in Figure 6-9. The EER includes the constant displacement compressor power as well as the parasitic power. The EER shown is substantially higher than that of conventional systems of 2.2 to 2.6 w/w (7.5 to 9 Btu/hr/watt), primarily because of the lower condensing and higher evaporating temperatures achieved with the highly efficient heat exchangers used in the system.

Concept C--Augmentation by Auxiliary Motor (Figure 6-10)

In Concept C, a high-frequency motor is packaged as an integral part of the tubocompressor to augment turbine power when necessary. A sketch of the machine, designed to provide 10.5 kw (3 tons) of air conditioning, is shown in Figure 6-11. The compressor and turbine are mounted at either end of the rotor. The motor rotor is on the same shaft between the compressor and turbine. The motor is designed to produce 2.0 kw of power at a speed of 63,000 rpm so that the entire compressor load can be handled by the motor with the turbine windmilling. Electrical power is supplied to the motor from a frequency converter which uses normal house three-wire 230-v, 60-Hz power for conversion to a frequency of 3150 Hz and a three-phase voltage of 120 v. The motor is a six-pole brushless design and uses a permanent magnet. In this application, constant speed operation has been selected to simplify the converter circuitry. As discussed later, if the system is used for heating as well as cooling, then a variable frequency converter may be necessary. In this case, motor speed would be adjusted for optimum COP under any heat source temperature by varying the frequency of the power input to the motor.

The motor is highly efficient; testing of similar machines have demonstrated efficiencies higher than 90 percent. Cooling of the motor is by the process fluid.

The rotor assembly is supported by two conical hydrodynamic foil bearings. The use of these bearings minimizes mechanical losses and obviates the requirements for special lubricant. This represents a significant advantage in system design.

Overall dimensions of the unit are shown in Figure 6-11. The weight of the machine is estimated at 12 lb. The high speed motor is very small, and its cost will be considerably lower than that of a comparable 60-Hz unit. The motor cost savings could be large enough to offset the cost of the frequency converter.

The rationale used in selecting the operating speed of the machine in the augmented mode is presented below, along with parametric performance data for system Concept C. The off-design performance computer program was used to generate the data in the augmented mode of operation.



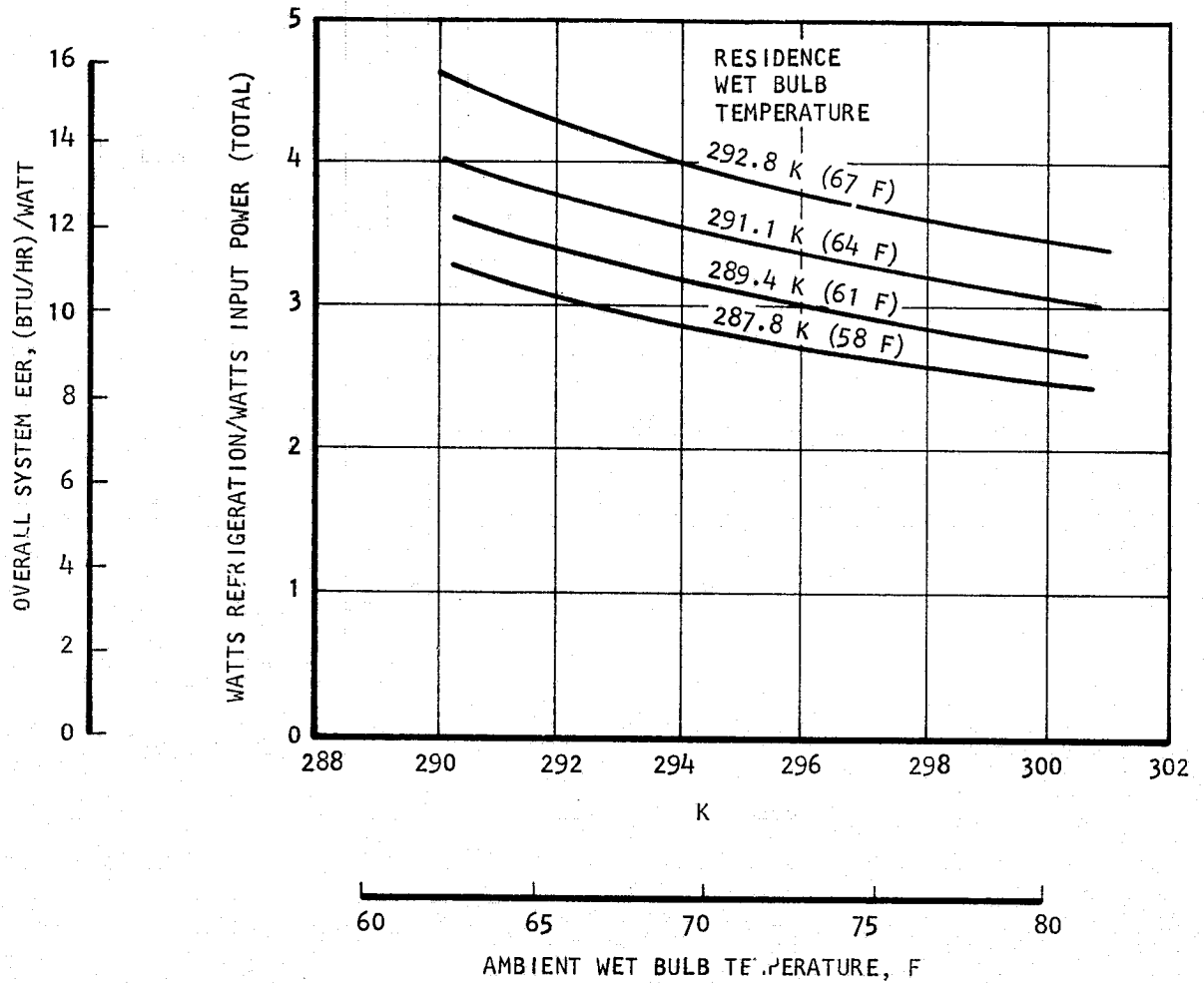

S-317

Figure 6-9. System EER with Auxiliary Compressor



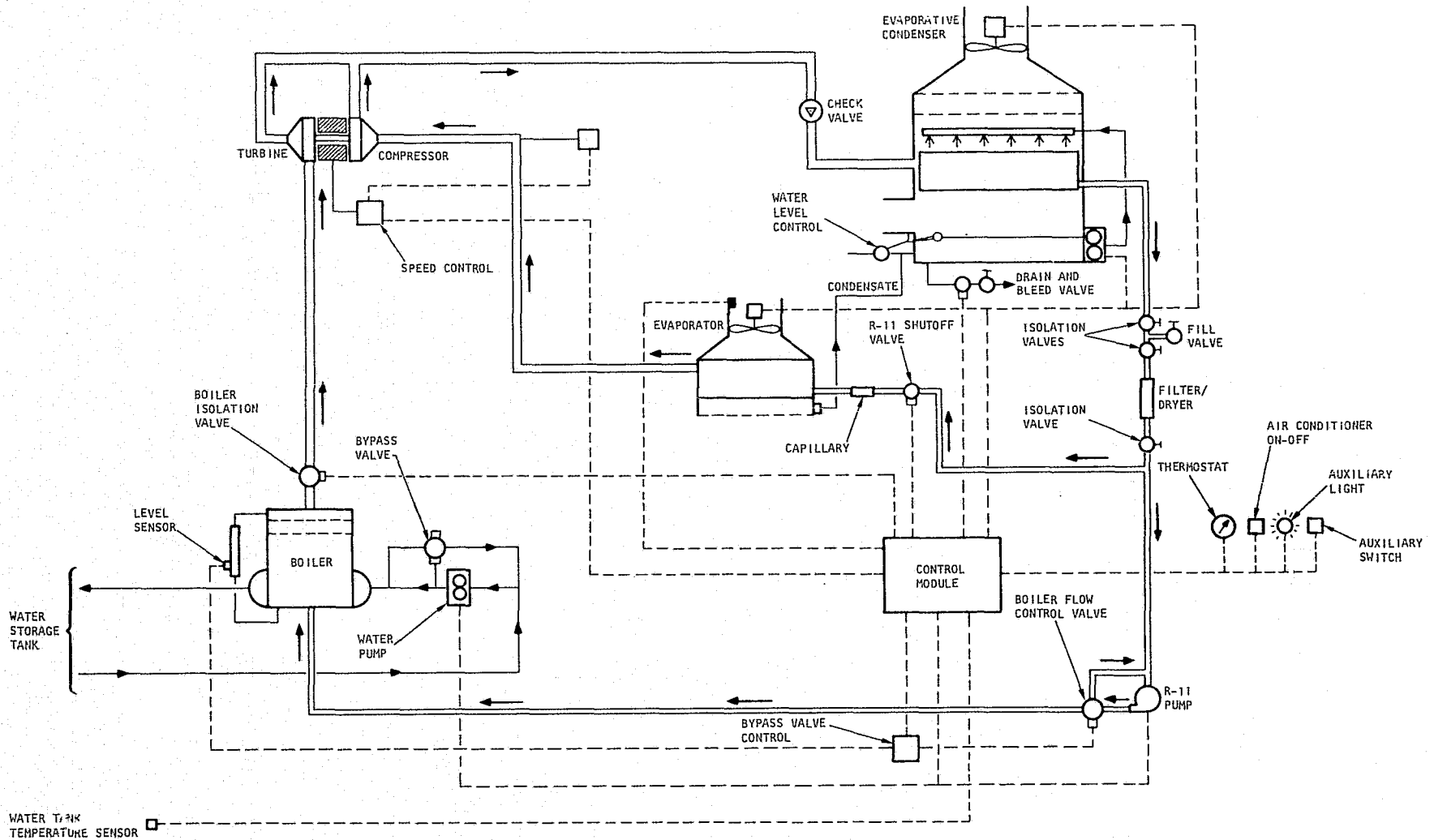

S-149

Figure 6-10. Concept C, Auxiliary Motor

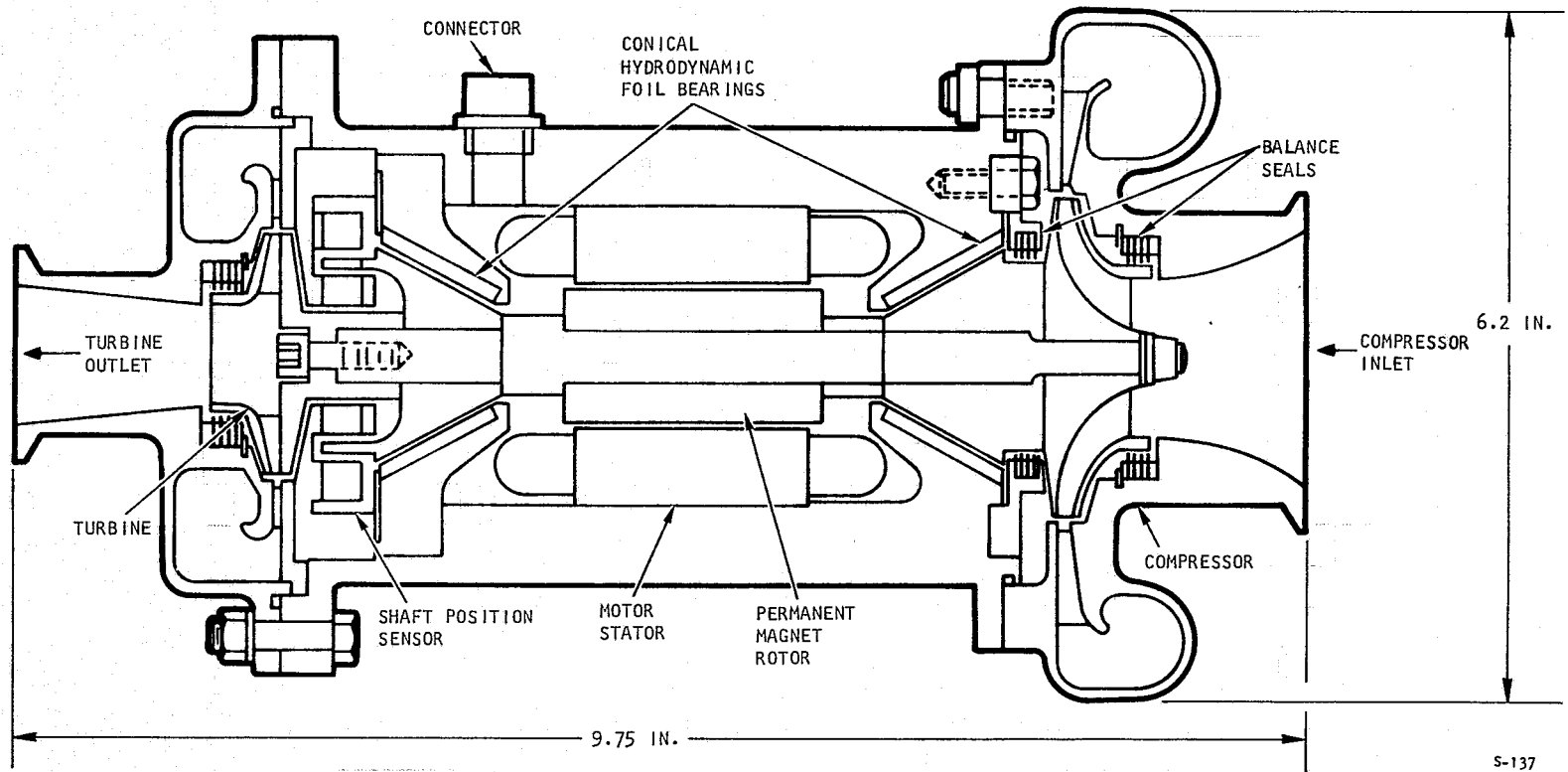

S-137

Figure 6-11. 3-Ton Turbocompressor with Integral Motor

1. Speed Selection in Augmented Mode

The turbocompressor design speed in the normal (non-augmented) mode of operation was determined to be 63,000 rpm. Potentially higher capacities could be obtained at higher speeds. An investigation was conducted to optimize the turbomachine speed in the augmented mode. Figures 6-12 and 6-13 show the efficiencies of the compressor and turbine for auxiliary motor speeds of 63,000 and 70,000 rpm respectively. The efficiencies are plotted as a function of water boiler temperatures over the entire range of ambient wet bulb temperature; residence wet bulb temperature has only a negligible effect on the efficiency parameters. Considerably higher efficiencies are obtained at the lower speed.

Over the entire range of water boiler temperatures, the higher speed results in lower compressor efficiencies--from 2 to 5 percent depending on the ambient wet bulb temperature. The effect on turbine efficiency is much more pronounced and can be as high as 9 percent at high ambient wet bulb temperature. As a result, the capacity increase due to higher motor speed is only on the order of 6 percent over most of the operating parameter range. Table 6-1 shows system capacity in the augmented mode corresponding to a water temperature at boiler inlet of 338.9 K (150 F). At that temperature, the turbine cannot sustain the compressor out of the surge range and motor augmentation is necessary for operation.

Comparison of the plots of Figures 6-12 and 6-13 also shows that at the 63,000 rpm speed the compressor and turbine efficiencies are maintained at much lower water temperatures, so that the useful operating range of the machine is extended. Little power could be derived from the solar heat source at low water temperatures (338.9 K (150 F)).

2. Potential Capacity Enhancement by Augmentation

In normal operation, without augmentation, the speed of the turbomachine will drop as less power is generated by the turbine at low boiler water temperatures. This will result in a capacity reduction as shown in Figures 5-1 through 5-4. This effect is illustrated in Figure 6-14; the plot was prepared for a residence wet bulb temperature of 289.4 K (61 F). At these particular conditions, the speed of the machine does not reach the maximum allowable of 76,000 rpm.

As the boiler water temperature drops below a certain value shown in the figure, the compressor will surge and augmentation will be necessary for operation. At this point, the motor is activated and controls the speed of the turbomachine at a constant preselected value (63,000 or 70,000 rpm, for example). In terms of turbine operation, this is analogous to a reduction of power requirement. The turbine will still develop some power, although the motor is activated and controls the speed.

Augmentation by motor activation is possible over the entire range of operation where the conditions are such that the normal speed of the turbocompressor is lower than the selected motor speed. Control in this manner is possible to enhance system capacity even in the range where the system could



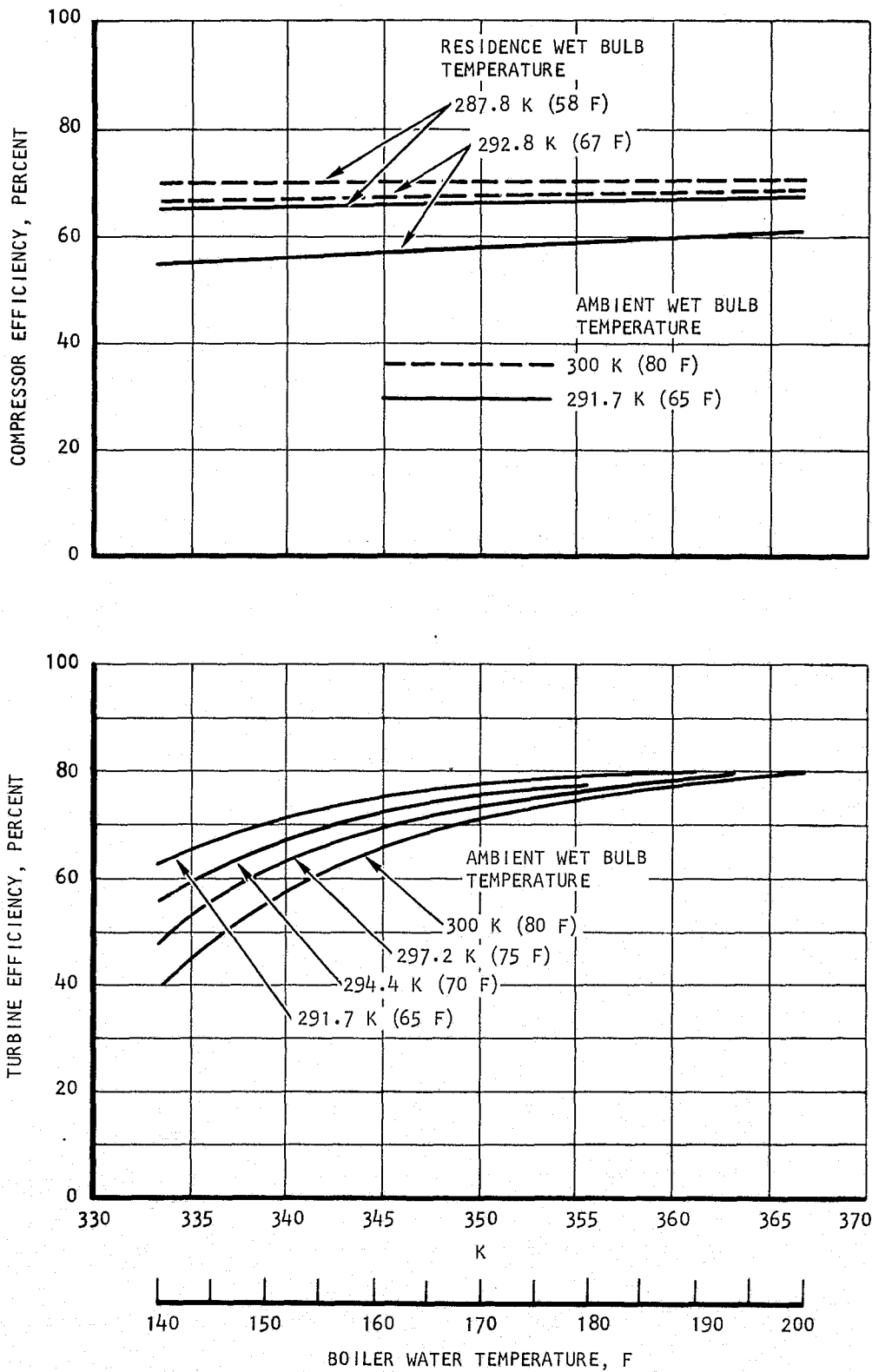

S-206

Figure 6-12. Compressor and Turbine Efficiency in the Augmented Mode-- Auxiliary Motor Speed = 63,000 rpm

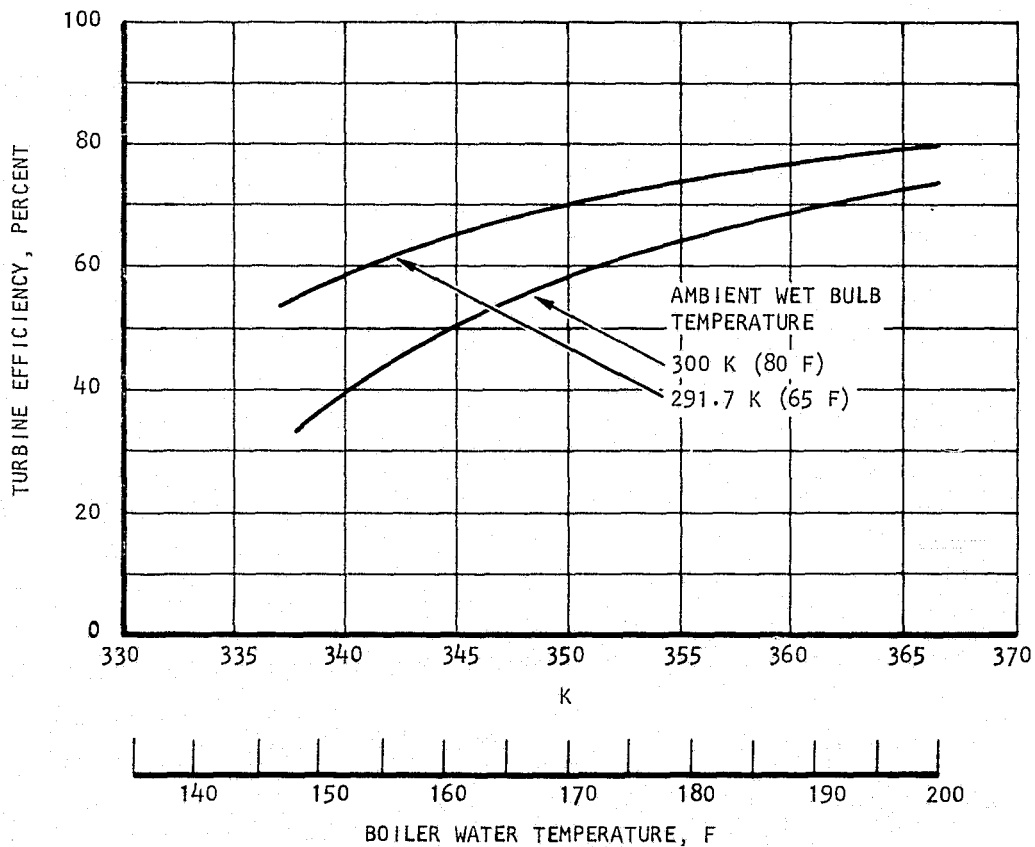
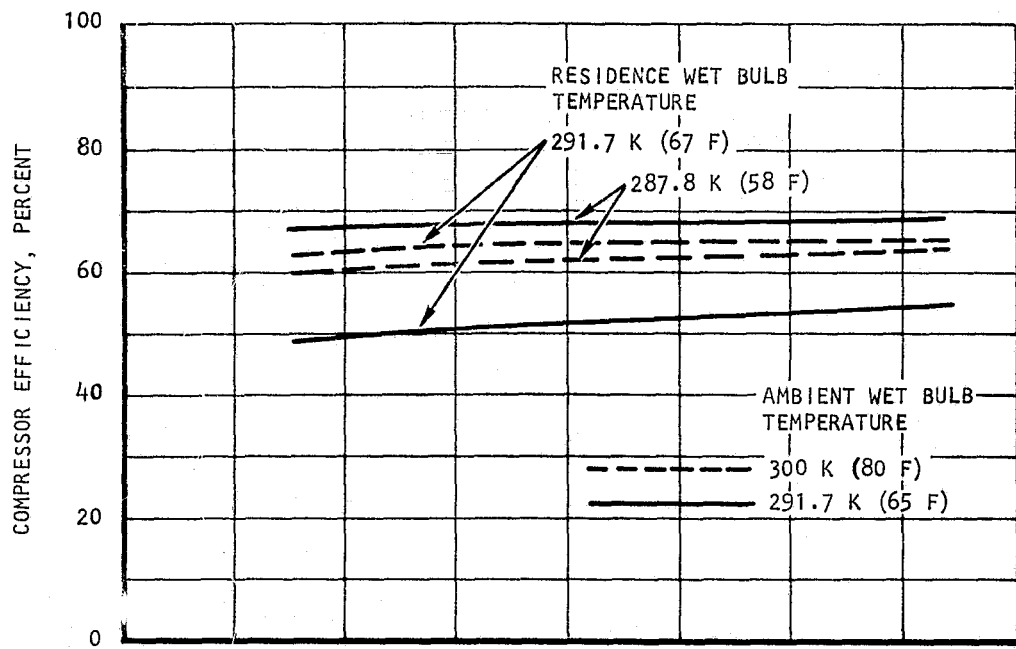

S-208

Figure 6-13. Compressor and Turbine Efficiency in the Augmented Mode-- Auxiliary Motor Speed = 70,000 rpm

TABLE 6-1

SYSTEM CAPACITY IN THE AUGMENTED MODE
(BOILER WATER TEMPERATURE = 338.9 K (150 F))

Turbomachine Speed	Ambient Wet Bulb Temperature, K (F)	System Capacity, kw (Btu/hr)						
		Residence Wet Bulb Temperature, K (F)						
63,000 rpm		287.7 (58)	289.4 (61)	291.1 (64)	292.7 (67)			
		291.7 (65)	8.9 (30,460)	9.5 (32,470)	10.2 (34,820)	10.9 (37,370)		
		294.4 (70)	8.8 (30,000)	9.4 (32,060)	10.1 (34,450)	10.8 (37,000)		
		297.2 (75)	8.5 (29,080)	9.2 (31,330)	10.0 (33,960)	10.7 (36,510)		
		300 (80)	8.1 (27,730)	8.9 (30,390)	9.8 (33,340)	10.6 (36,010)		
		70,000 rpm		287.7 (58)	289.4 (61)	291.1 (64)	292.7 (67)	
				291.7 (65)	9.5 (32,400)	10.1 (34,420)	10.8 (36,770)	11.6 (39,700)
				294.4 (70)	9.4 (32,100)	10.1 (34,120)	10.7 (36,470)	11.4 (39,020)
297.2 (75)	9.3 (31,720)			10.0 (33,750)	10.7 (36,130)	11.3 (38,570)		
300 (80)	9.2 (31,350)			9.8 (33,400)	10.5 (35,810)	11.2 (38,260)		



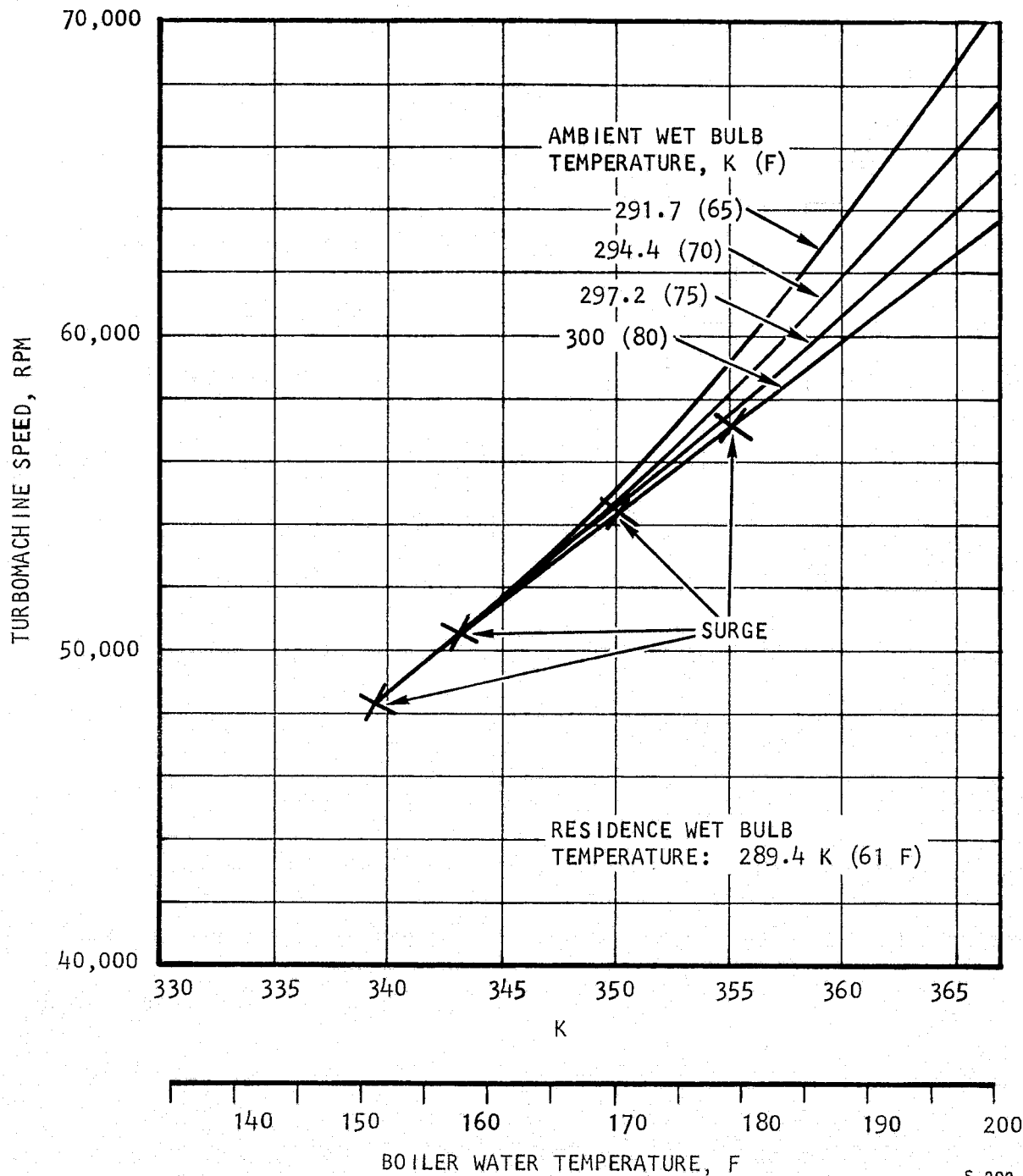

S-202

Figure 6-14. Turbomachine Speed in Normal (Non-Augmented) Mode



be operated normally. This would involve starting the motor when the house temperature exceeds the upper thermostat setting by a given preset value, say 1 K (2 F).

Figures 6-15 and 6-16 show the additional capacity that could be achieved by motor activation in the normal range of operation. The data are presented for motor speeds of 63,000 and 70,000 rpm and for a fixed value of the residence wet bulb temperature 289.4 K (61 F). Also shown is the electrical power expended in providing the added system capacity. As will be shown later, the system electrical energy requirement (EER) in the non-augmented mode varies between 5.3 and 7.6 watts/watt (18 and 26 Btu/hr/watt) over the range of boiler and ambient wet bulb temperatures shown in Figure 6-14. By comparison, the EER achieved by augmentation in the normal mode is between 3 and 4.5 watts/watt (9 and 16 Btu/hr/watt). Thus, the added capacity is about twice as costly in terms of auxiliary energy as the baseline capacity. For this reason, automatic capacity enhancement by auxiliary power was rejected.

Note that conventional systems do not offer this option and that the capacity of such systems also will degrade under operating conditions (ambient and residence wet bulb temperatures) less favorable than rated conditions. Incorporated in the system, however, are provisions for manually activating the motor when desired.

Comparison of the data in Figures 6-15 and 6-16 indicates much lower EER at a motor speed of 70,000 rpm, although the added capacity is increased. This is due to the lower compressor-turbine efficiencies at higher speed as discussed above.

A motor speed of 63,000 rpm was selected for augmentation.

3. Minimum Boiler Water Temperature

When auxiliary motor operation is required to prevent compressor surge, the turbine still has the capability to furnish a relatively large portion of the total power necessary to drive the compressor. This is illustrated in Figure 6-17 for a residence wet bulb temperature of 289.4 K (61 F). Residence wet bulb temperature has only a minor effect on the parameters plotted. The turbine contribution to the total power required is significant at boiler water temperature near that corresponding to compressor surge. As the water temperature drops, the turbine power drops and becomes only a small portion of the total power requirement at high ambient wet bulb temperature. This is due to a rapid deterioration of turbine efficiency (see Figure 6-12).

It is desirable to disengage the turbine at low efficiency to conserve solar thermal energy, even though it is in a low grade form. Yet it is also desirable to operate the system with the turbine at water boiler temperatures as low as 333.3 K (140 F) under conditions of low wet bulb temperatures. A compromise solution, which will be implemented with simple control circuitry, is to disable the turbine when the boiler water temperature drops below 336.1 K (145 F). Under ambient wet bulb temperature conditions representative of average values in a hot humid climate (244.4 K (70 F)), it is estimated that 35 percent of the total compressor power is developed by the turbine. Referring



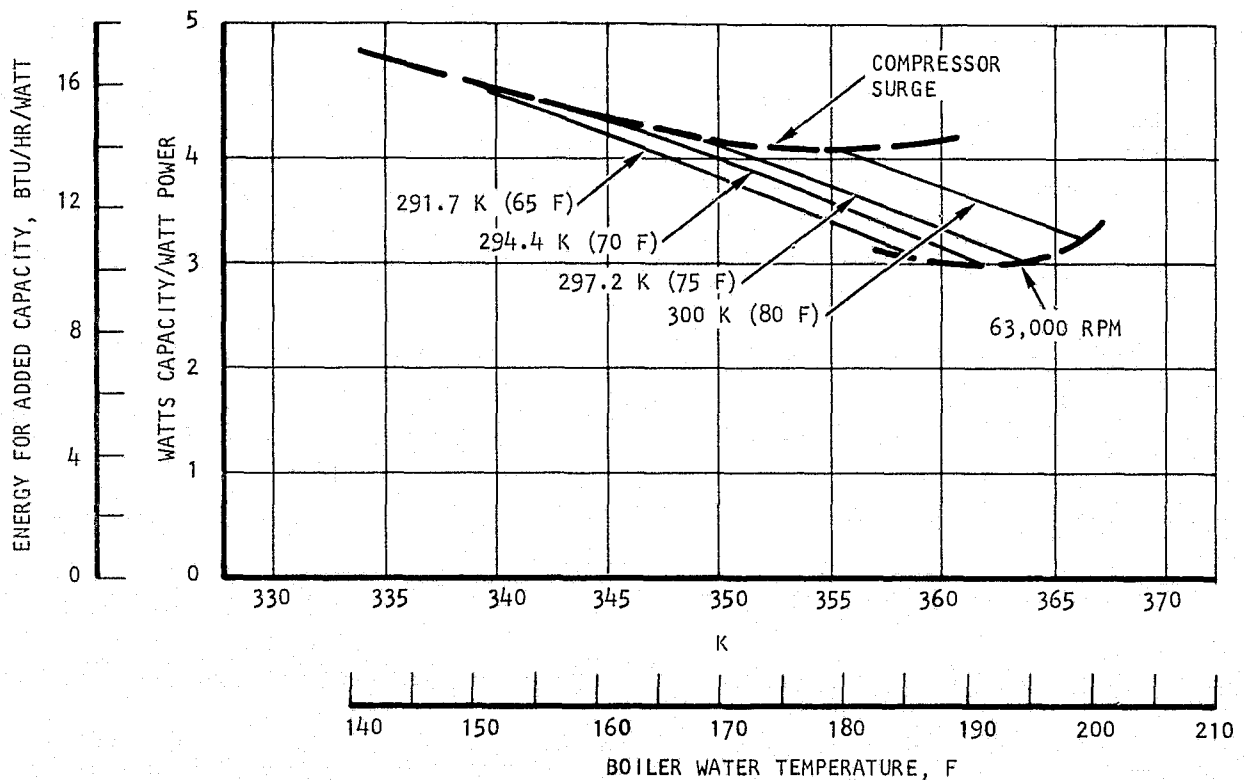
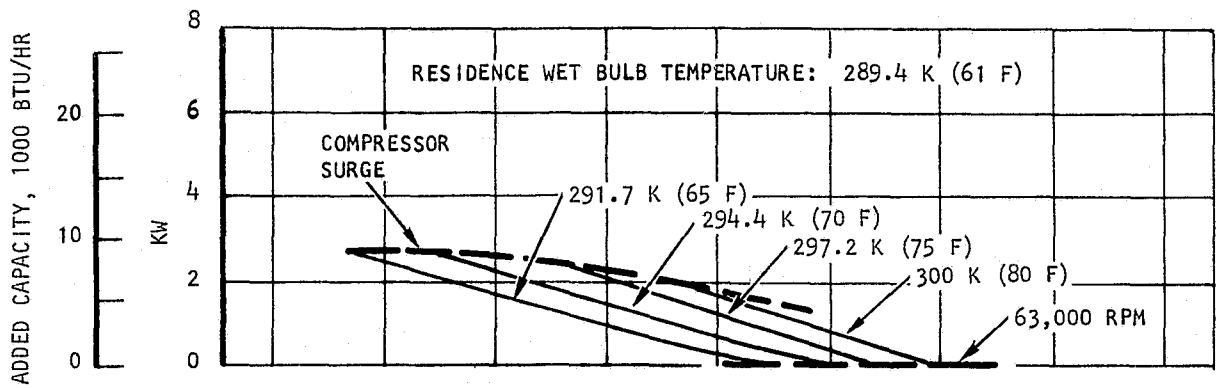

S-209

Figure 6-15. Potential Capacity Enhancement in the Normal Range of Operation--Auxiliary Motor Speed = 63,000 rpm; Residence Wet Bulb Temperature = 284.4 K (61 F)

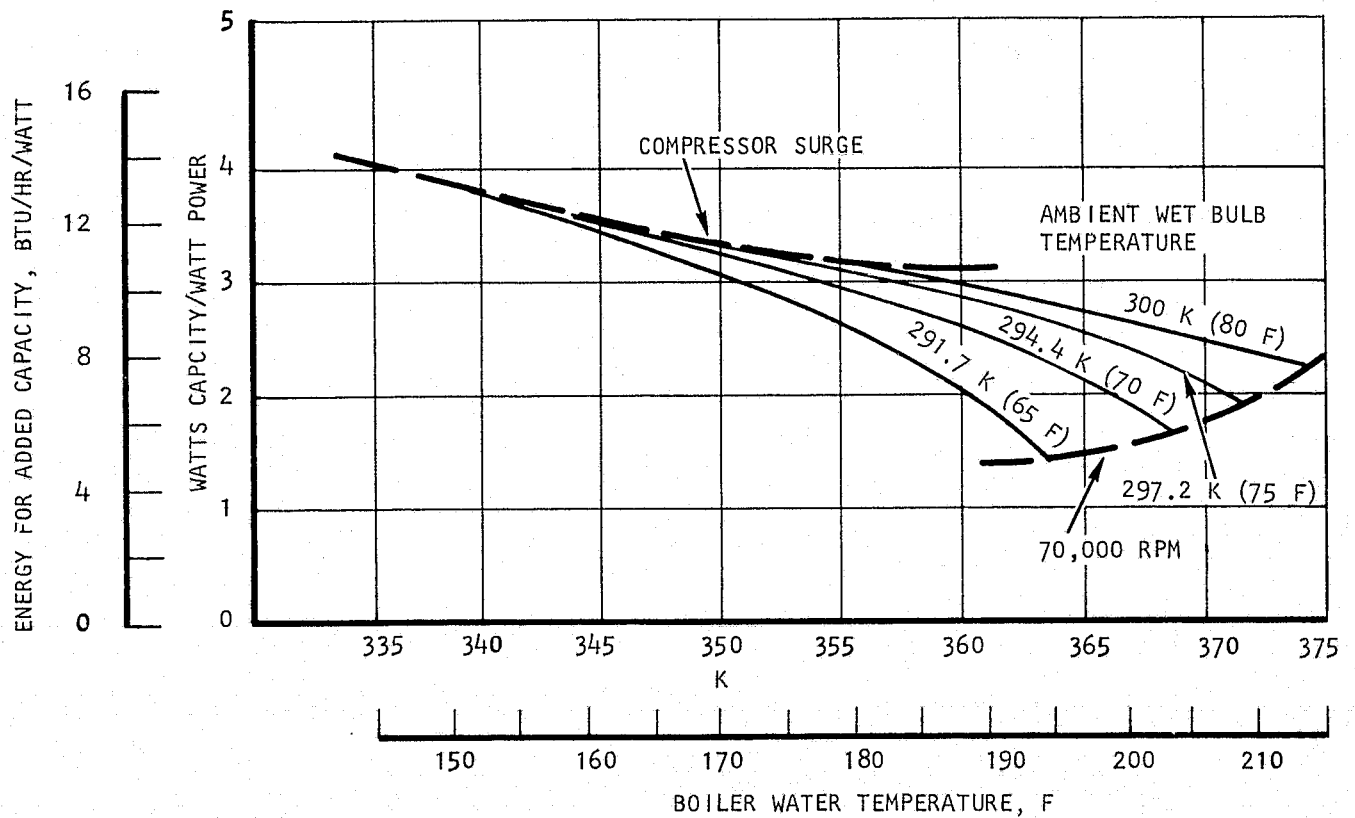
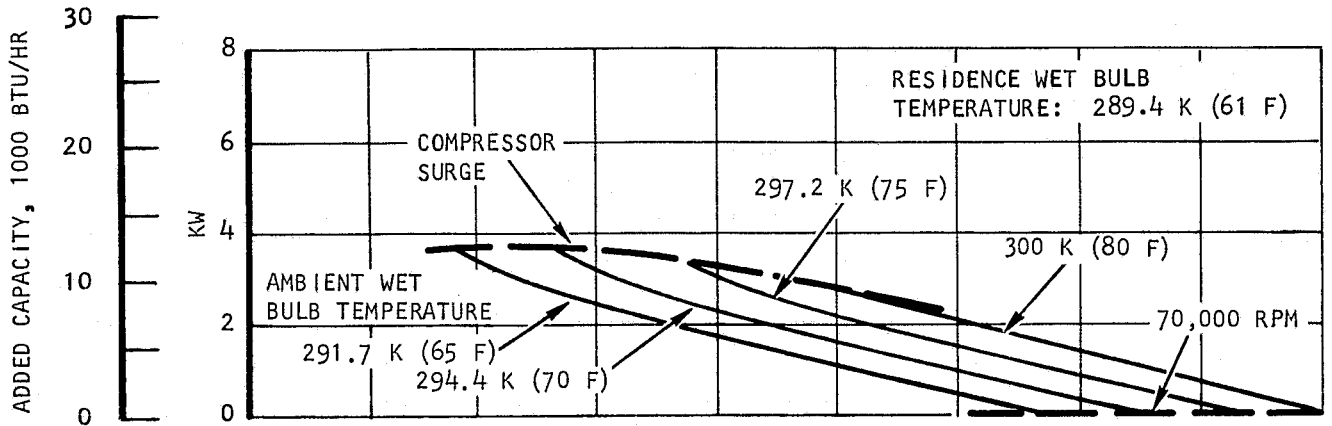

S-205

Figure 6-16. Potential Capacity Enhancement in the Normal Range of Operation--Auxiliary Motor Speed = 70,000 rpm; Residence Wet Bulb Temperature = 284.4 K (61 F)

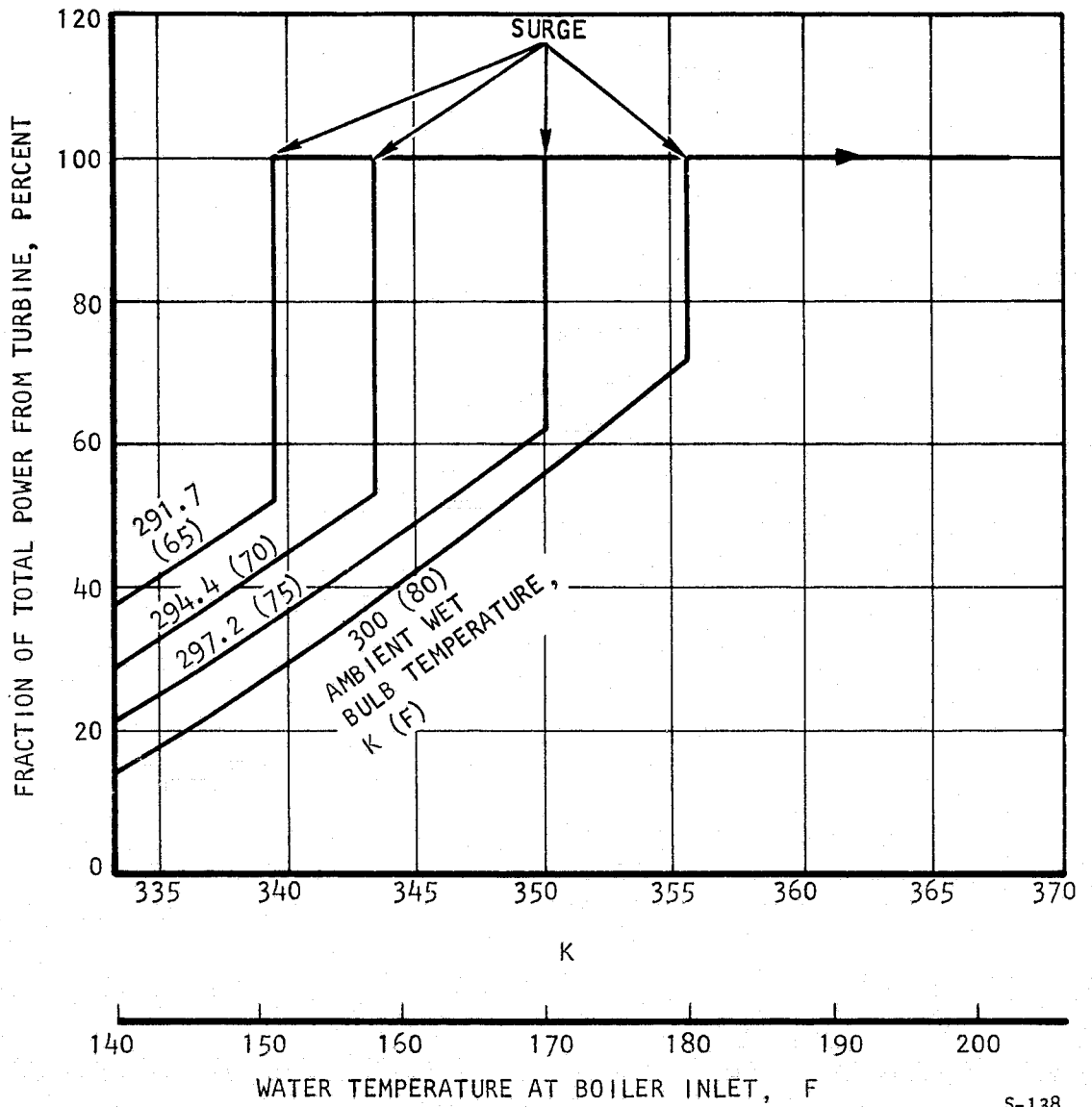

S-138

Figure 6-17. Fraction of Power Supplied by Turbine



AIRSEARCH MANUFACTURING COMPANY
OF CALIFORNIA

to Figure 6-10, a water temperature sensor in the water storage tank will shut off the water pump and isolate the boiler when the temperature drops below 336.1 K (145 F).

4. System Operational Modes

Figure 6-18 illustrates the system characteristics in various operational modes. Capacity, auxiliary power, and electrical energy requirement variations are shown plotted as a function of water temperature at boiler inlet.

Operation of the system with its control scheme is as follows:

- (1) At high boiler water temperature, large quantities of energy are available at the turbine. Turbocompressor speed will be excessive in terms of stress considerations. This condition will occur at boiler water temperatures in excess of 372.2 K (210 F). Turbomachine overspeed protection is provided by a wax element type bypass valve in the hot water line to the boiler. The valve will open at a temperature of 372.2 K (210 F) and bypass water around the boiler; the quantity of water bypass will be such as to limit the heat input to the boiler in order to maintain turbocompressor speed below 76,000 rpm.
- (2) As the boiler temperature drops, turbocompressor speed will also decrease. The capacity of the system and its EER will drop. Under these conditions, the only electric power used by the system is for operation of the fans, pumps, and controls. All turbocompressor power is developed by the turbine. This is the normal mode of operation of the system.
- (3) As the turbomachine speed decreases to a value approaching compressor surge speed, a surge sensor will activate the auxiliary motor, which will accelerate the turbomachine to design speed--63,000 rpm. Surge will occur at different speeds and compressor flows depending on the system interfacing parameter. With the auxiliary motor "on", system capacity will increase significantly. However, the EER will continue to decrease as the boiler water temperature drops and less power is developed by the turbine and assumed by the auxiliary compressor. Since the turbomachine speed is constant, system capacity is also constant.
- (4) A further drop in water boiler temperature will result in system boiler shutdown and operation with the auxiliary motor alone.

5. System Parametric Data

Figures 6-19 through 6-22 present parametric performance data for the Rankine air conditioner augmented by means of an electric motor integral with the turbocompressor. Each figure corresponds to a different residence wet bulb temperature, covering the range from 392.8 to 387.8 K (67 to 58 F). The data are presented as illustrated in Figure 6-18.



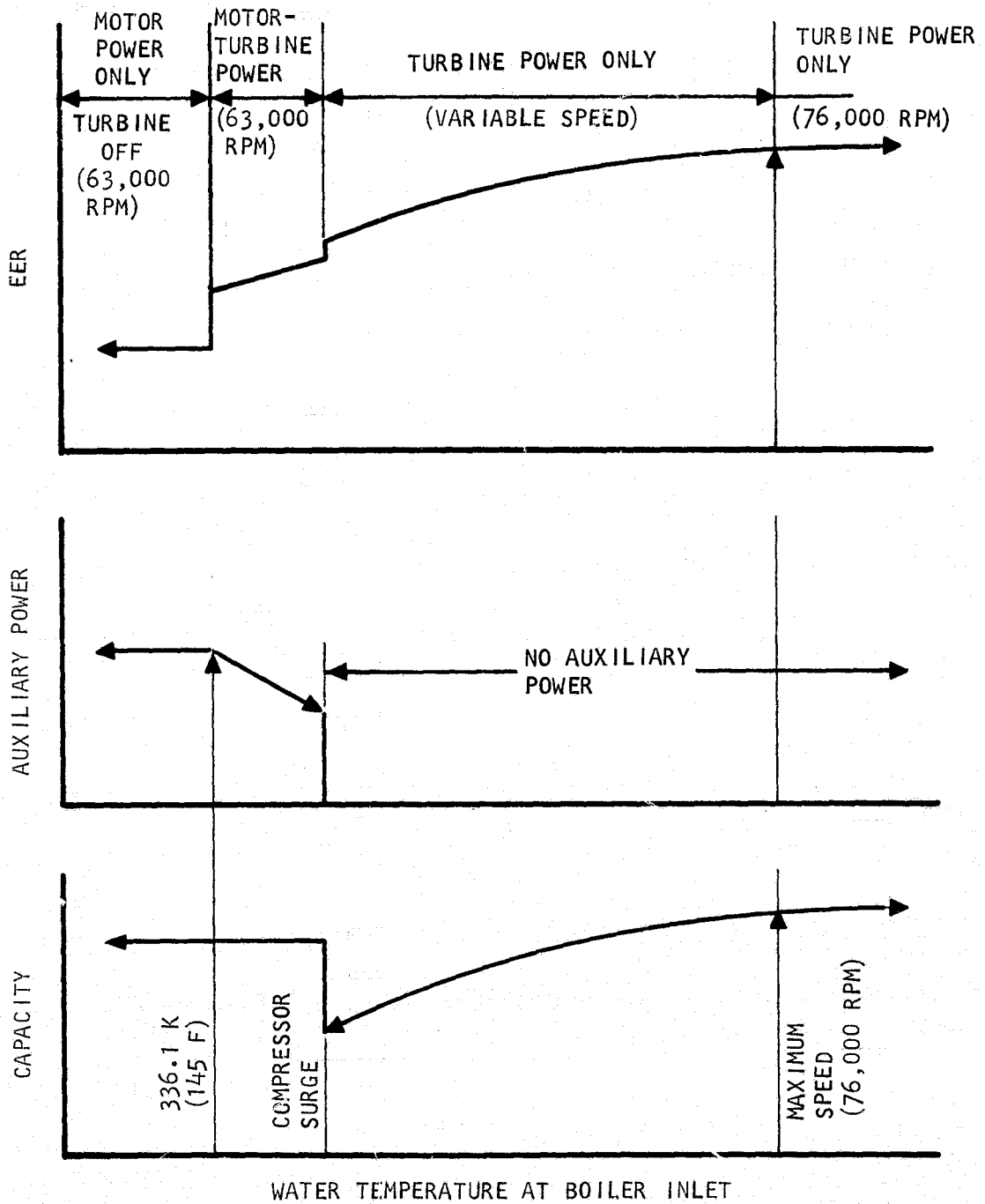

Figure 6-18. Typical Operational Modes

S-203



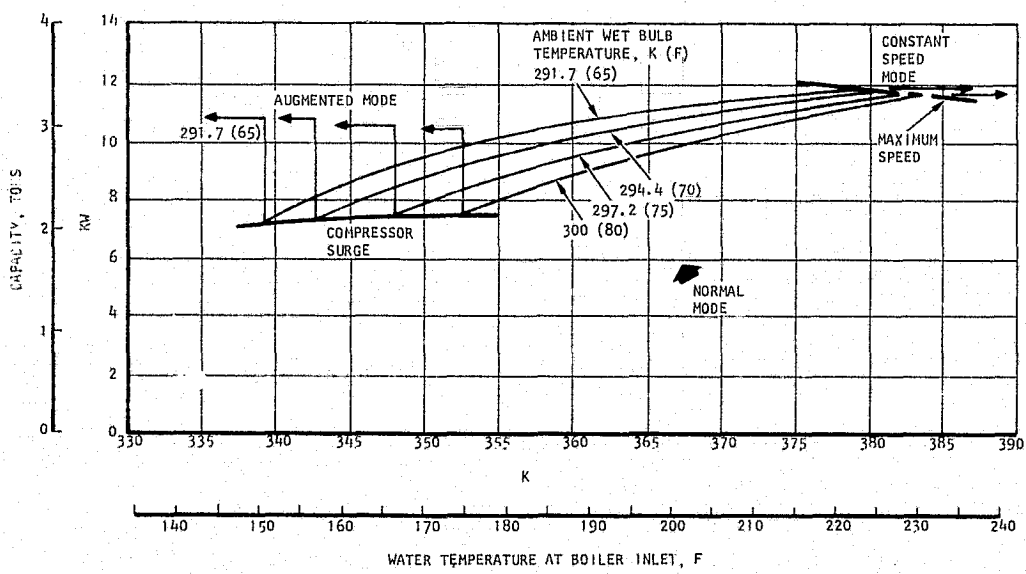
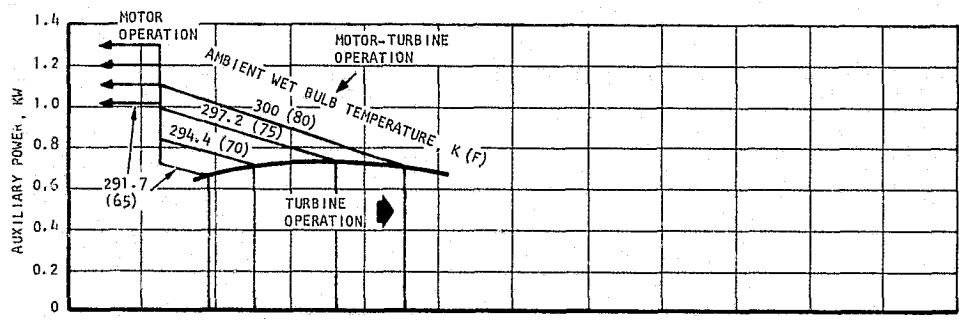
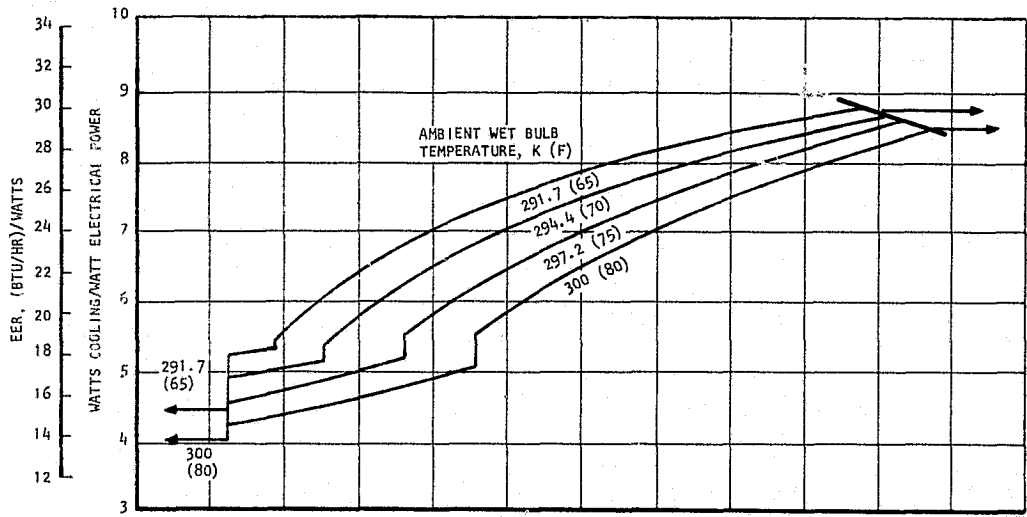
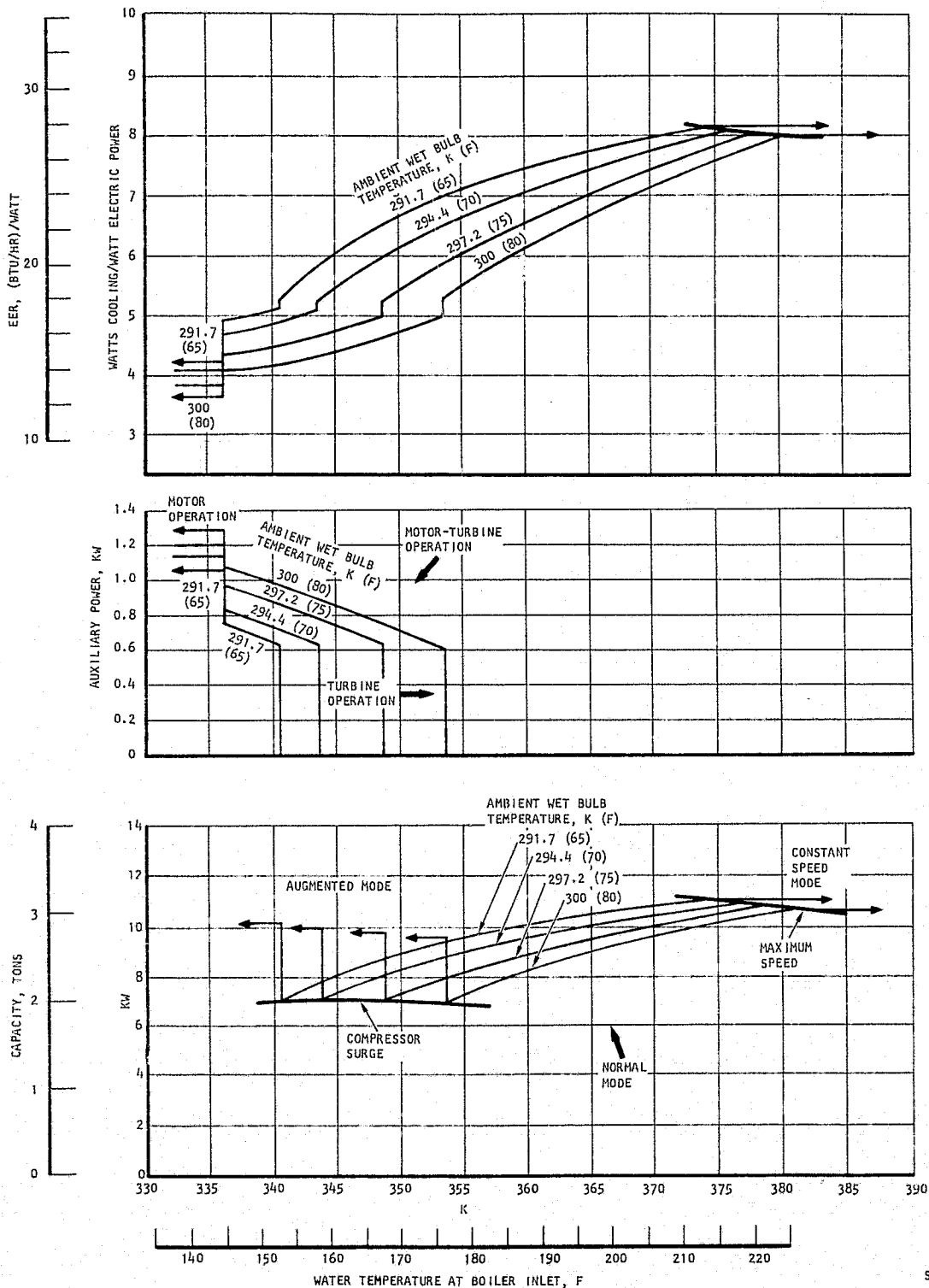

Figure 6-19. Auxiliary Motor System Performance--Residence Wet Bulb Temperature = 392.8 K (67 F)





S-192

Figure 6-20. Auxiliary Motor System Performance---Residence Wet Bulb Temperature = 291.1 K (64 F)



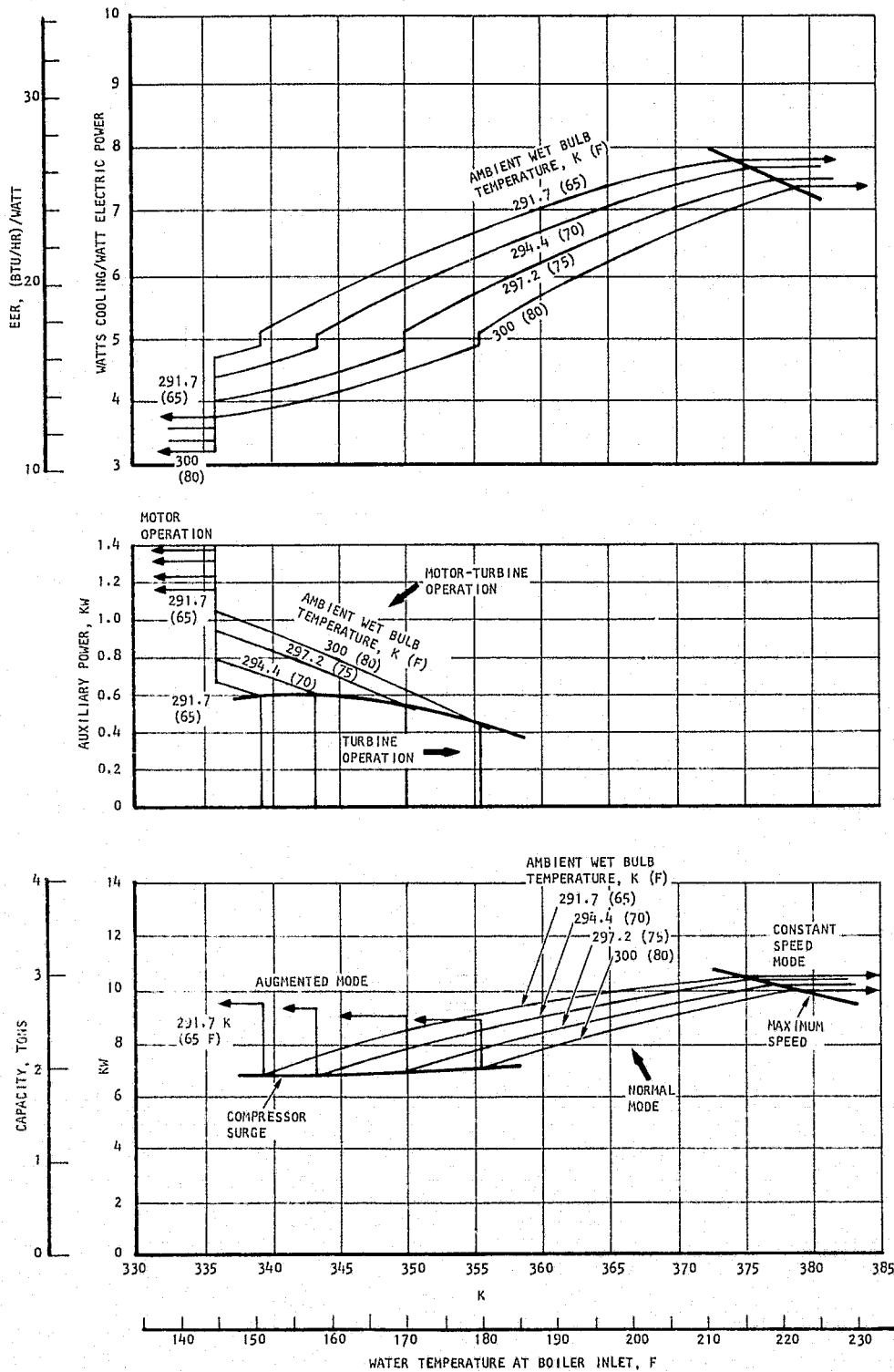

Figure 6-21. Auxiliary Motor System Performance--Residence Wet Bulb Temperature = 289.4 K (61 F)



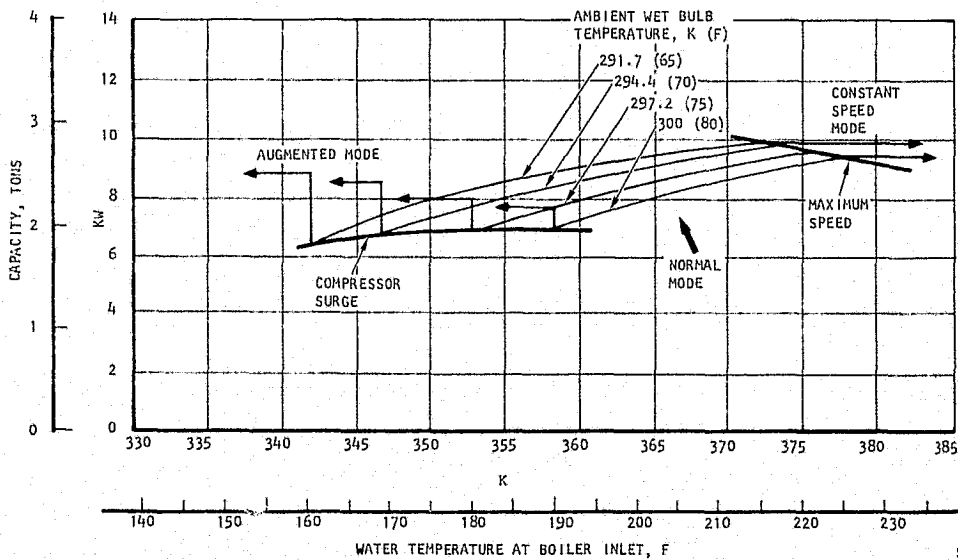
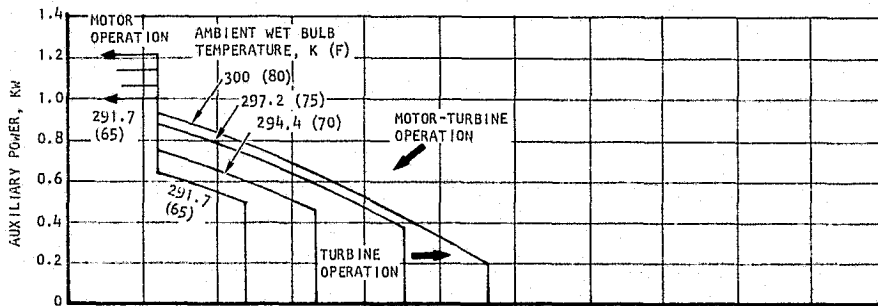
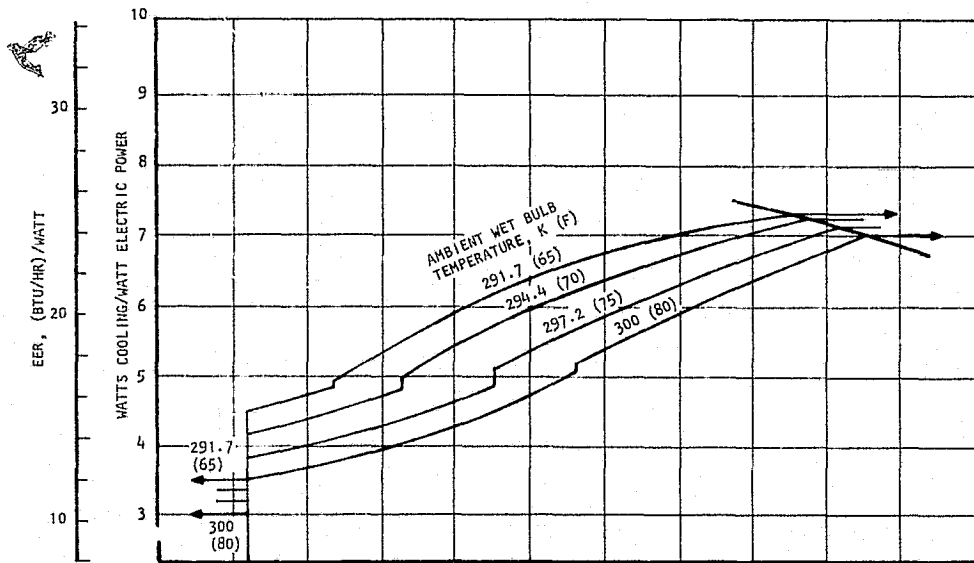

Figure 6-22. Auxiliary Motor System Performance--Residence Temperature = 287.8 K (58 F)



Comparison of Augmentation Concepts

Figure 6-23 shows the performance of the system in the augmented mode using the three approaches considered:

- Auxiliary heater
- Auxiliary compressor
- Auxiliary motor

The data were plotted for typical ambient and residence wet bulb temperatures over the range of boiler water temperature of interest.

The auxiliary heater approach is extremely wasteful of energy since the auxiliary heat is used to produce power in a loop which typically has an efficiency of about 10 percent. This is evidenced by the EER characteristic of this approach. Even if gas or fuel oil were used at a unit cost of 25 percent of that for electricity, this approach is not comparable to either of the other two concepts considered. The efficiency of the auxiliary compressor/motor at design point is about the same as that of the converter/motor/centrifugal compressor (0.56). As a result, these two approaches have similar characteristics. At water boiler temperatures below 336.1 K (145 F), the auxiliary motor concept has higher capacity and slightly lower power requirement due to better off-design characteristics. As a result, the auxiliary motor concept has an EER which is 15 percent lower than that of the auxiliary compressor--a significant performance advantage.

Where the auxiliary motor approach is decisively better is in the range of boiler water temperatures from 343.3 K to 336.1 K (158 to 145 F). Here, considerable auxiliary power savings can be realized through operation of the turbine-motor combinations. This difference will be larger yet at higher ambient wet bulb temperature.

For this reason, the auxiliary motor concept is selected as optimum.



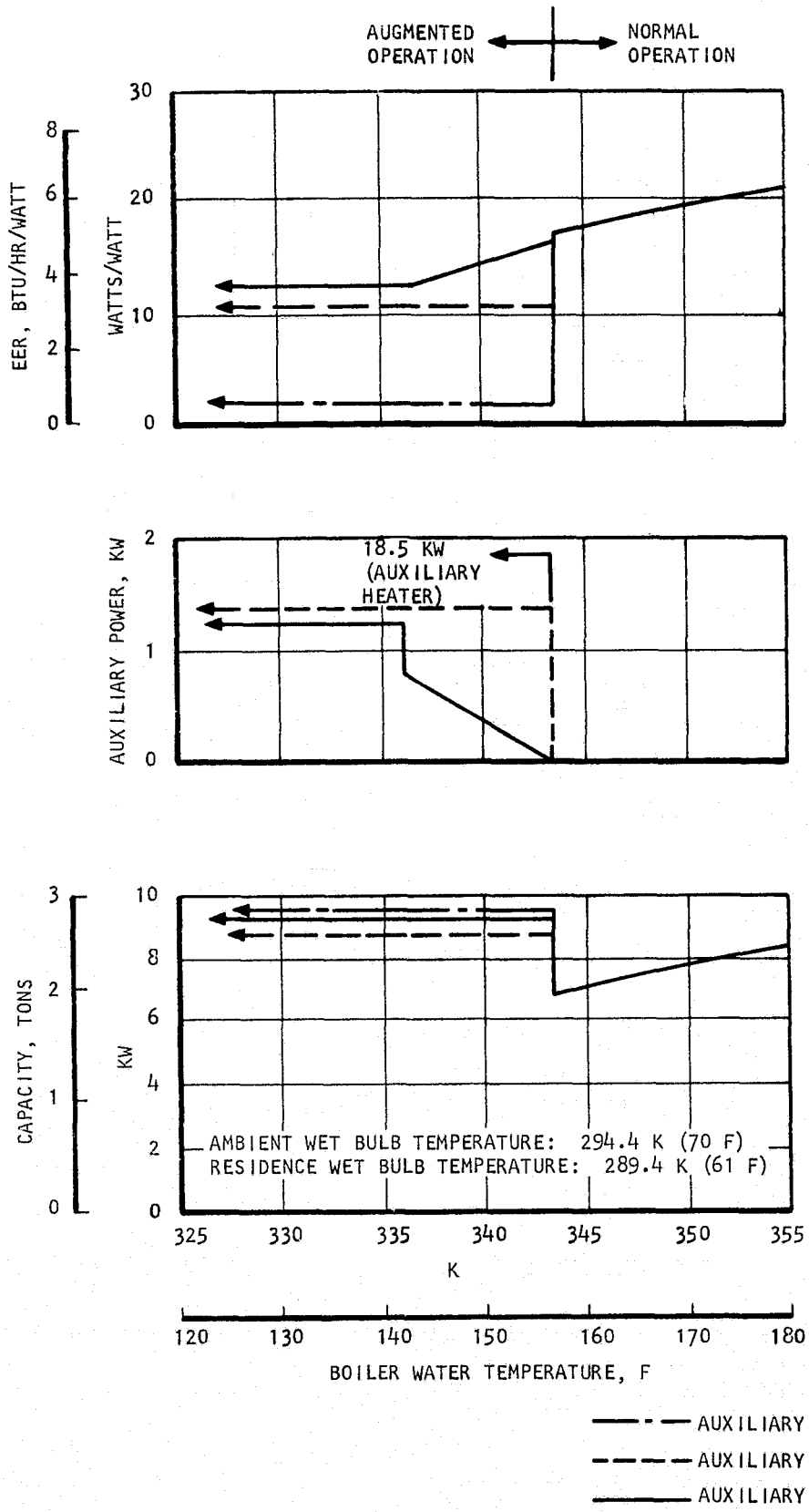

Figure 6-23. Comparison of Augmentation Concepts

S-207

SECTION 7
SYSTEM EVALUATION

GENERAL

To completely evaluate the Rankine air conditioner and its broad operational range, it is necessary to determine its characteristics in the context of the complete solar system. To this end, a system model was developed to simulate operation in the NASA-MSFC solar house and thus provide a direct comparison with the LiBr/H₂O absorption water chiller, which has been subjected to extensive testing as part of the solar house program.

A schematic of the system is shown in Figure 7-1. The off-design computer program was further developed to model the complete solar system depicted. The collector, storage tank, and house data obtained by NASA during the period from August 19 through 23, 1974, were reduced to the format necessary for use by the program. The program was then exercised to simulate operation with the interface parameters corresponding to actual experimental data from the solar house.

The results of these investigations are summarized, following a comparison of the off-design characteristics of the Rankine and LiBr/H₂O absorption system.

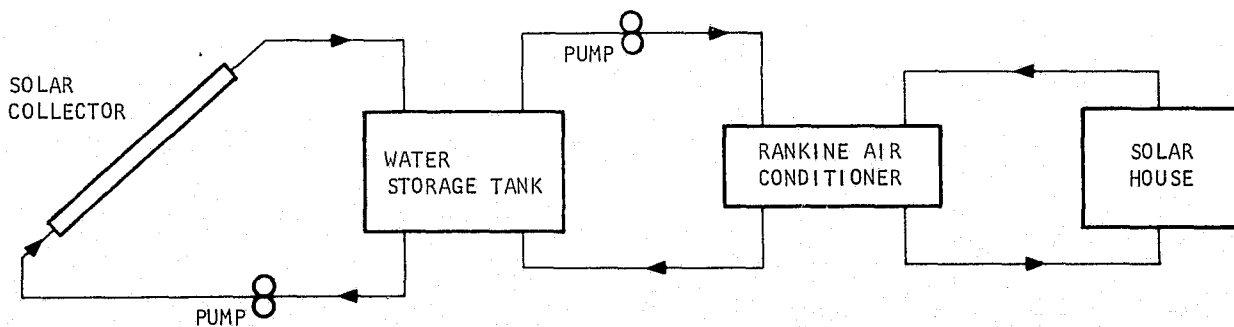

S-433

Figure 7-1. Solar System Schematic

OFF-DESIGN COMPARISON OF RANKINE AND ABSORPTION SYSTEMS

The off-design performance data of Arkla Industries Solaire system, Model 501-WF, were obtained from a recent Arkla brochure (Form No. SP 52T-1). These characteristics are plotted in Figure 7-2, with comparable Rankine system data presented previously. The data shown cover the non-augmented mode of operation only. In Figure 7-1, it was assumed that the cooling water

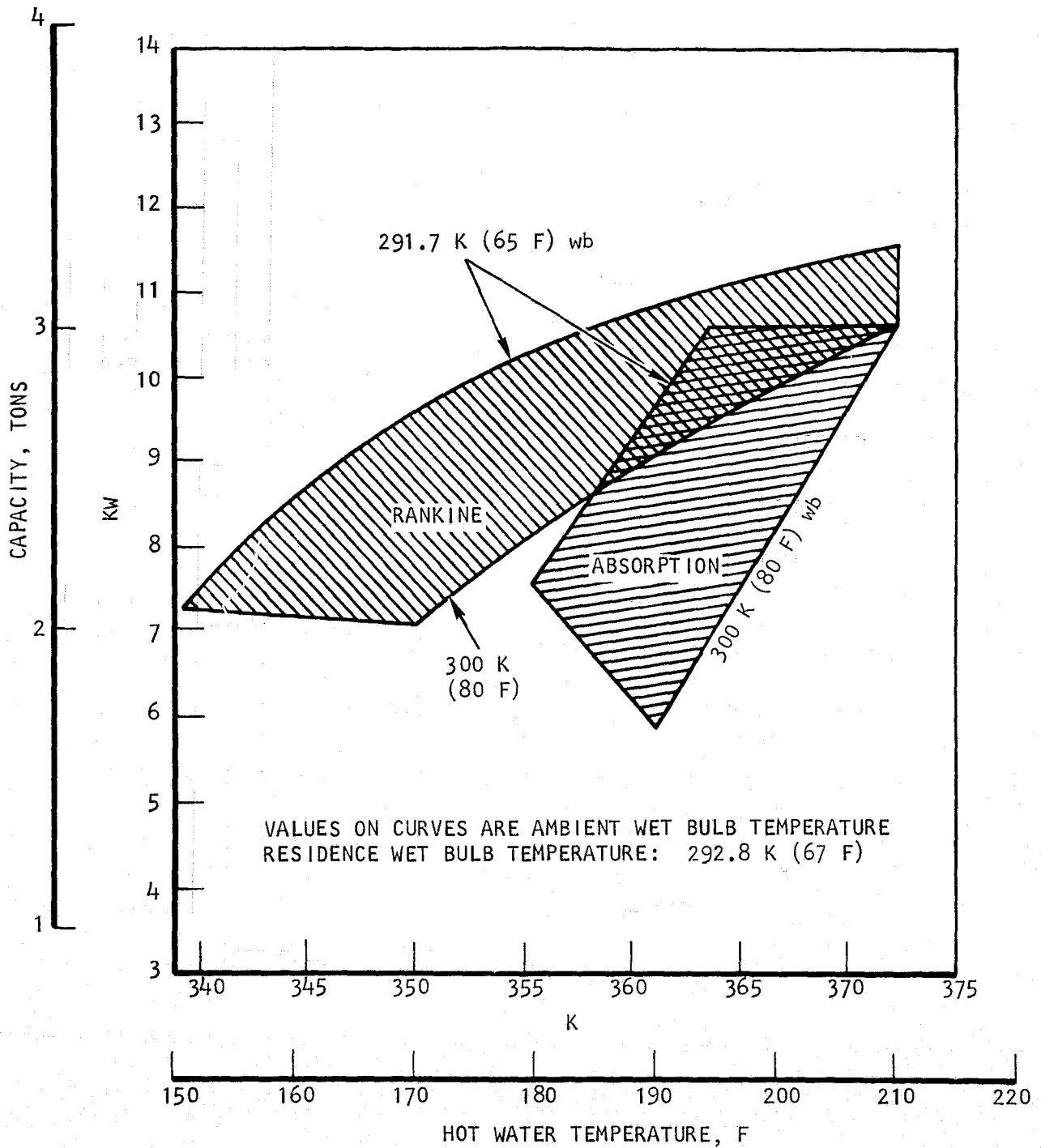

S-440

Figure 7-2. Comparison of Rankine and Absorption System in Non-Augmented Mode



temperature to the absorption system would be only 2.8 K (5 F) higher than the ambient wet bulb temperature. This is representative of a very effective cooling tower.

The operating range of the Solaire system is shown to extend to water temperatures as low as 355.5 K (180 F) with a low ambient wet bulb temperature. Capacity drops rapidly with the temperature of the hot water source.

By comparison, the utility of the Rankine system extends to hot water temperatures approaching 338.9 K (150 F), while the capacity remains high over the entire range of water temperature.

In the augmented mode, the absorption system will have an EER comparable to that of the auxiliary heater concept. By comparison, the Rankine system has an EER 6 to 8 times as large. Also, the requirement for auxiliary power with the Rankine system occurs at a hot water temperature about 11 K (20 F) lower.

SOLAR SYSTEM COMPUTER PROGRAM

The methodology used by the computer program is illustrated in Figure 7-3. The computations are performed as follows. First, system component characteristics are computed using the design computer program. Design point conditions are used for this purpose. Second, a time interval is taken over which the input variables are assumed constant (average value). Then the calculations proceed along the following steps:

- (a) Water temperature at boiler inlet is determined from the water tank temperature and the tank-to-air conditioner heat losses.
- (b) Using the boiler water temperature and ambient and residence wet bulb temperatures, the off-design program determines if augmentation is necessary. System capacity and COP are determined; in the augmented mode auxiliary power also is calculated. Water temperature at boiler outlet is calculated.
- (c) System capacity is compared to the house heat load (input). If the capacity exceeds the load, the fraction of the time period considered during which the air conditioner is "on" is calculated; energy expenditure for the time period is computed. If the capacity is lower than the demand, auxiliary power is used to enhance system capacity.
- (d) The heat used by the air conditioner is calculated.
- (e) The heat losses through the tank-air conditioner pipes, the collector-tank lines (if any), and the water storage tank are calculated. A heat balance is performed on the tank, accounting for the energy collected during the time period considered and the heat used by the air conditioner. Tank water temperature at the end of the interval is determined.



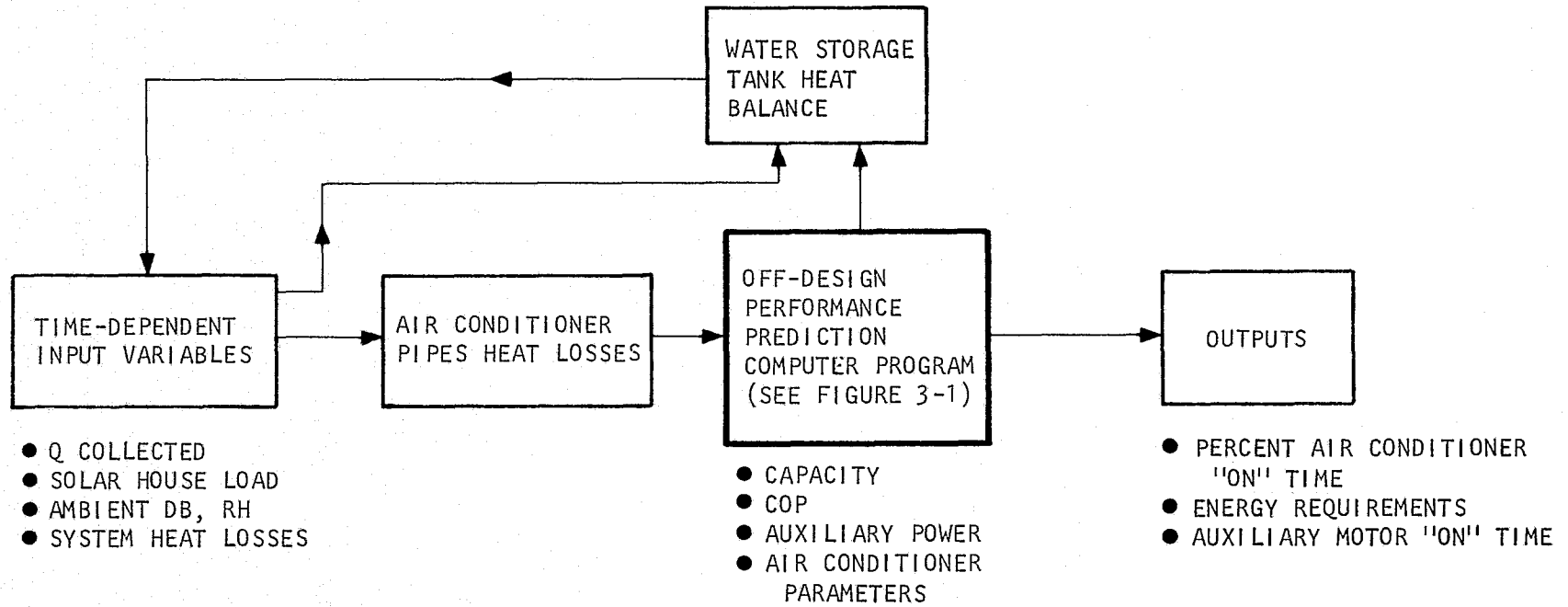

S-432

Figure 7-3. Solar System Computer Program Methodology

- (f) Summations are made of the energy requirements, and calculations are repeated for the next time interval.

DATA AND ASSUMPTIONS

The data and assumptions used by the off-design computer program have been discussed previously. The solar system computer program utilizes a modified form of the off-design program so that these data and assumptions hold. In addition, the listing below describes the values and the source of the input data used in the evaluation of the air conditioner.

- (a) Heat collected by the 1300 sq ft NASA solar house flat plate solar collector: this parameter is identified as Q COLLECTED (item 1.7.7) in the NASA test data sheets.
- (b) The solar house loads were also obtained from the NASA test data sheets. The QAC APP plot (item 5.39) vs Time was smoothed out and the slope of the resulting curve was used as the solar house load.
- (c) Ambient temperature (db) and relative humidity were taken as T-021 and RH-02 (items 5.2.4 and 4.1.1) of the data sheets. Again, these data were smoothed out to account for instrumentation peculiarities and provide better average values over short time intervals.
- (d) System heat losses were derived from the NASA test data. Heat losses in the system pipes and storage tank were estimated from the appropriate temperature plots. These losses were then apportioned to yield 58.6 kw-hr/day (200,000 Btu/day), which represents the long-term average obtained. The following values were used to describe the particular NASA solar house installation:
- (1) Collector-tank pipes: 21.1 w/K (40 (Btu/hr)/F)--these losses will occur only during the heat collection period.
 - (2) Water storage tank: 13.2 w/K (25 (Btu/hr)/F)--these losses are continuous.
 - (3) Tank-air conditioner pipes: 15.8 w/K (30 (Btu/hr)/F)--these losses will also occur continuously with the exception of the time when the system is in the augmentation mode.
- (e) The house dry bulb temperature was taken as 297.2 K (75 F). This temperature was prevalent during the test period of August 18 through 23, 1974. The house wet bulb temperature was not measured; a value of 291.1 K (61 F) corresponding to a relative humidity of 45 percent was assumed. The performance maps in Section 6 show this low value of the residence temperature as not favorable to the performance of the Rankine air conditioner.
- (f) The water tank is assumed to be completely mixed. The water tank capacity was taken as 15,454 kg (34,000 lb) H₂O.



Figures 7-4 through 7-8 are plots of ambient temperature and RH, Q COLLECTED, and house heat loads for August 19 through 23, 1974. These data were obtained from the NASA test data as discussed above.

SYSTEM COMPUTER PROGRAM

The nomenclature for the input data and examples of input and output computer printouts are presented in Appendix B. A copy of the program listing has been furnished to NASA under separate cover.

SYSTEM PERFORMANCE

The performance of the Rankine air conditioner over the five-day period considered is presented in Figures 7-9 through 7-13. Data shown include the following:

- (a) Water storage tank temperature history--the starting value of 358.3 K (185 F) on August 19 was taken from the NASA data sheets
- (b) The system heat losses
- (c) The thermal energy used to power the air conditioner
- (d) The electrical energy to sustain system operation--only the electrical power necessary to operate the air conditioner as defined in Figure 6-10 is considered here

A summary of the data is listed in Table 7-1.

The thermal COP of the air conditioner varied from 0.66 to 0.52 during the 5-day period. The low COP's corresponded to the very high wet bulb temperature (300 K (80 F)) at the end of day 2 (August 20). The average COP over the entire period was approximately 0.6.

The Rankine air conditioner carried the entire solar house load without auxiliary energy except for very short periods on day 5 (August 23). On that day, 0.8 kw-hr of auxiliary energy was used. Parasitic power for fans, pumps, and controls is estimated at 1350 watts when the system is in operation. Total electrical energy requirement for the 5-day period is calculated to be 83.7 kw-hr for an average of 16.7 kw-hr per day.

It is interesting to note here that on days when reasonable quantities of thermal energy were collected with the solar collector, the water storage tank temperature from time 0 to 24 hr did not change appreciably or increase (see days 1, 2, and 5). Days 3 and 4 represent worse case situations where the air conditioning load is high and yet little solar energy is available to the system. This is an abnormal situation which is believed to be due to control problems with the experimental solar collector subsystem. Even on these worse days, no auxiliary energy is necessary to drive the Rankine system. Water storage tank temperature dropped to 346 K (164 F) during these two days.



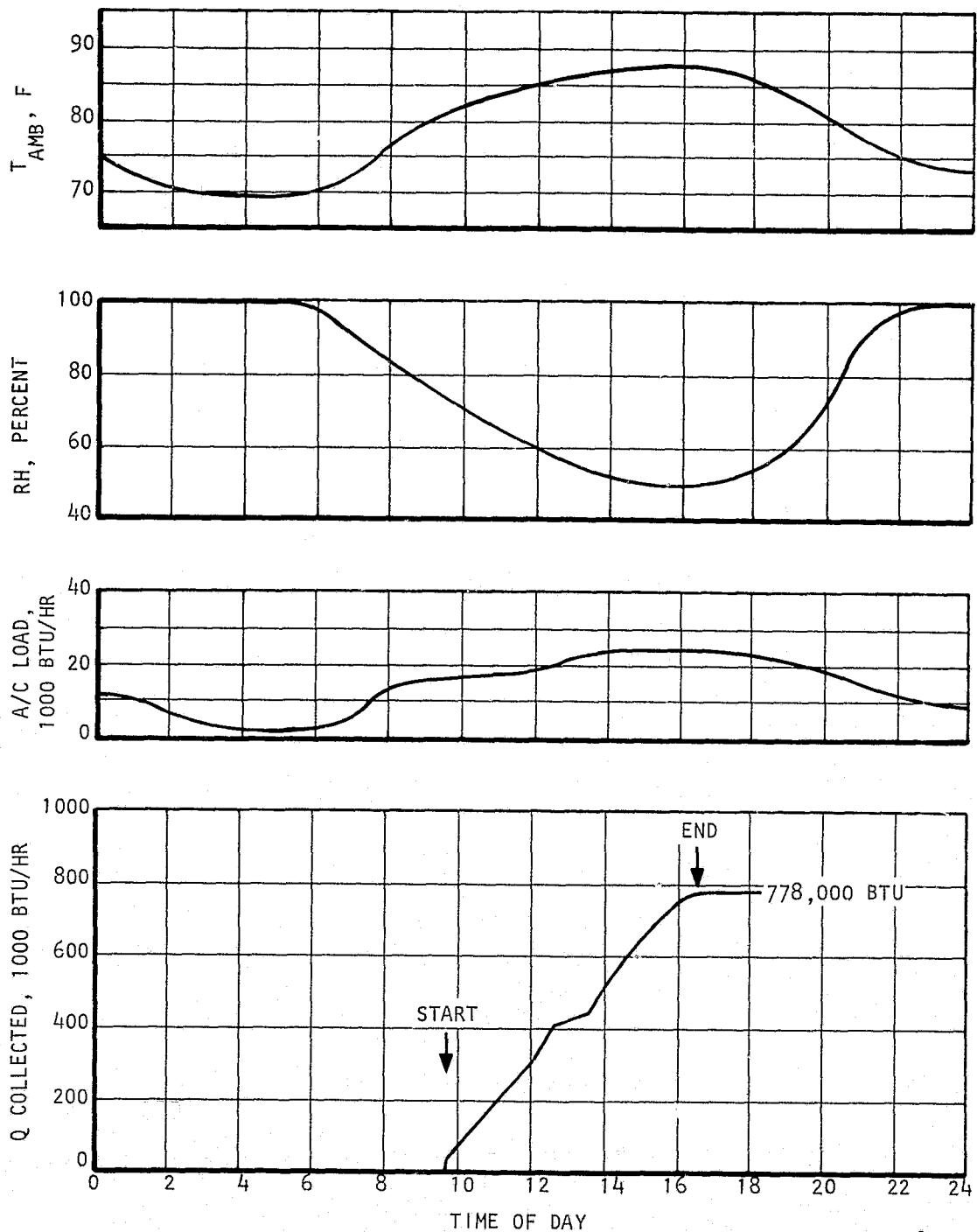

S-357

Figure 7-4. Solar House Data (8-19-74)



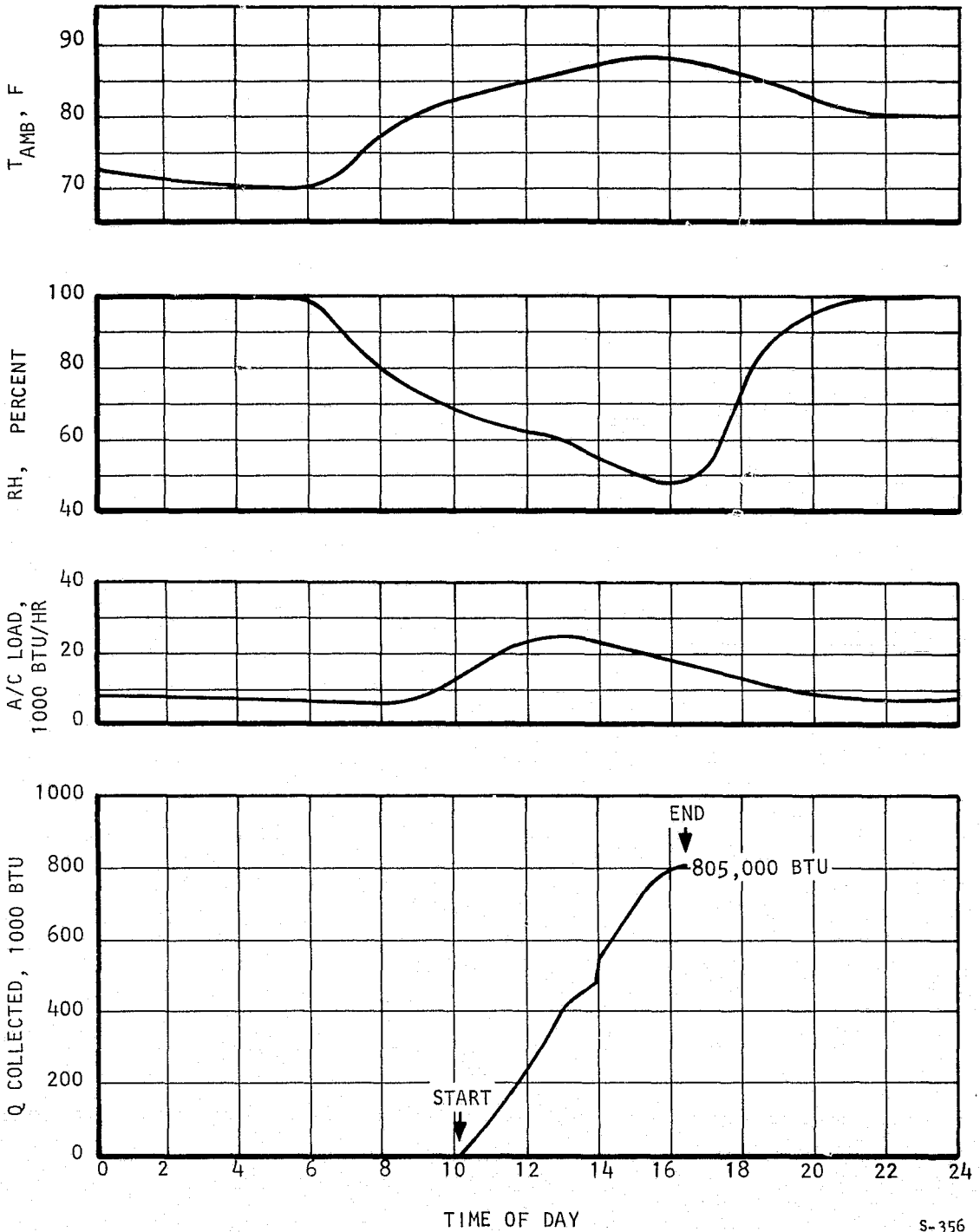

S-356

Figure 7-5. Solar House Data (8-20-74)



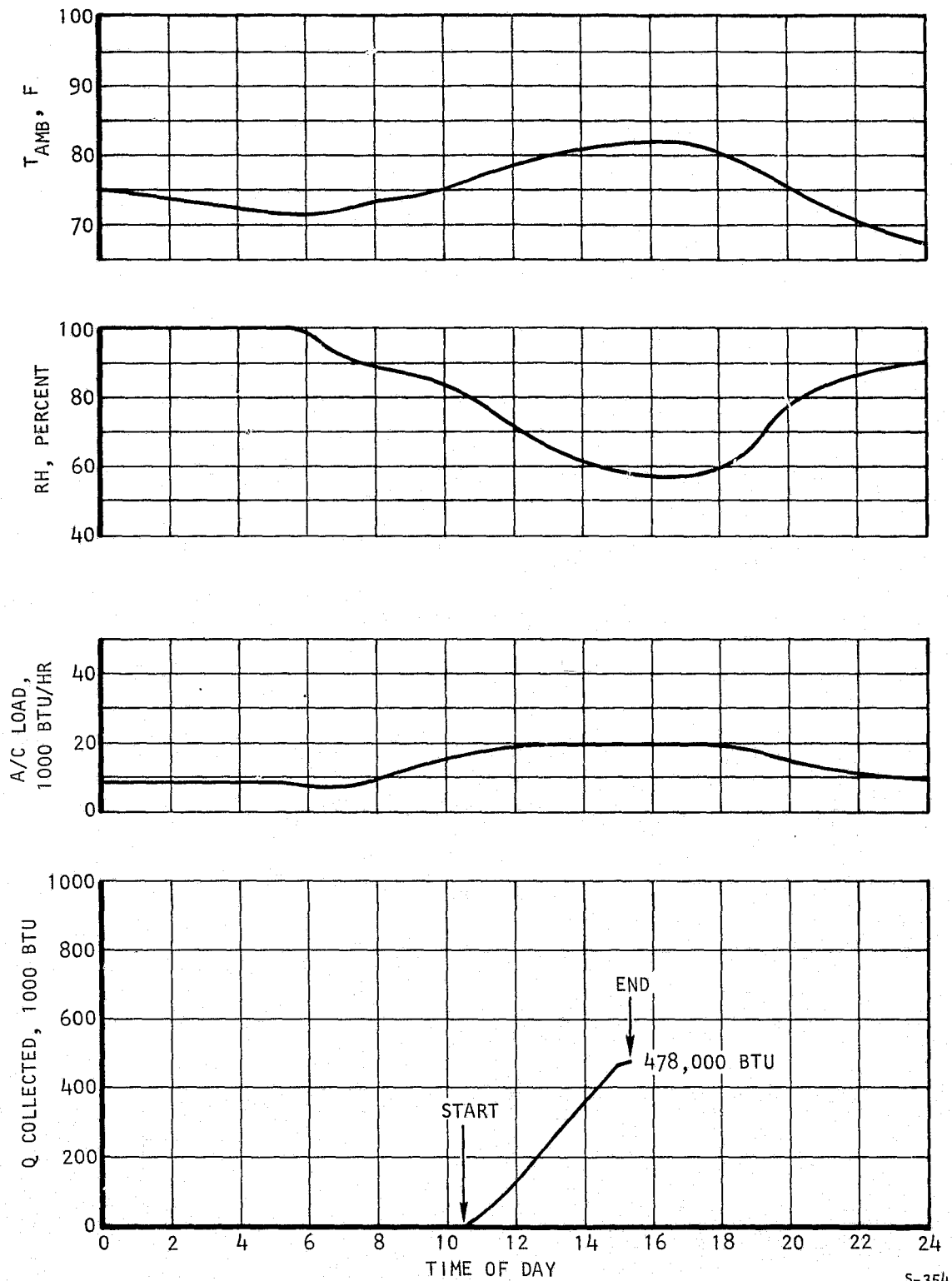

S-354

Figure 7-6. Solar House Data (8-21-74)



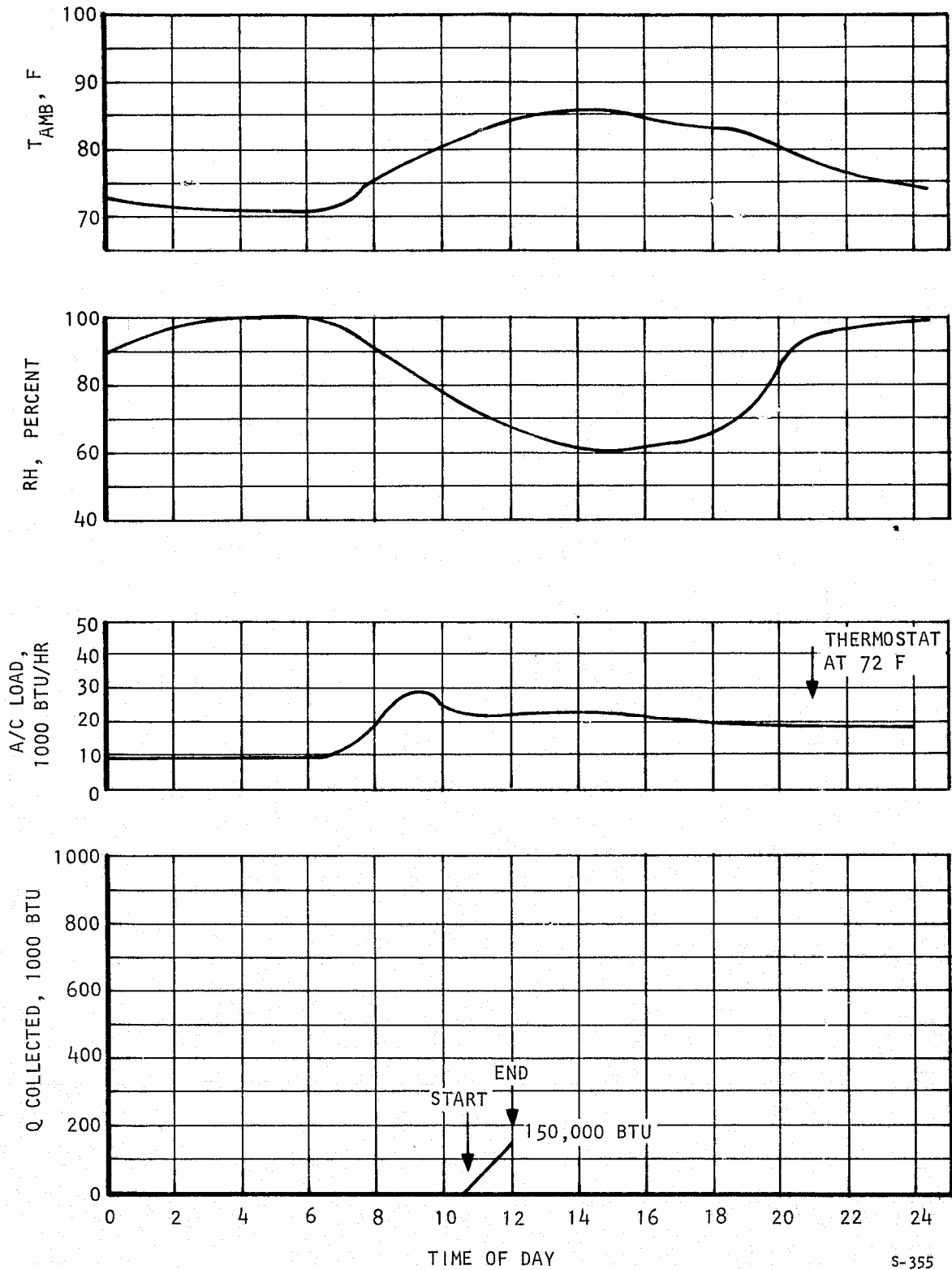

S-355

Figure 7-7. Solar House Data (8-22-74)



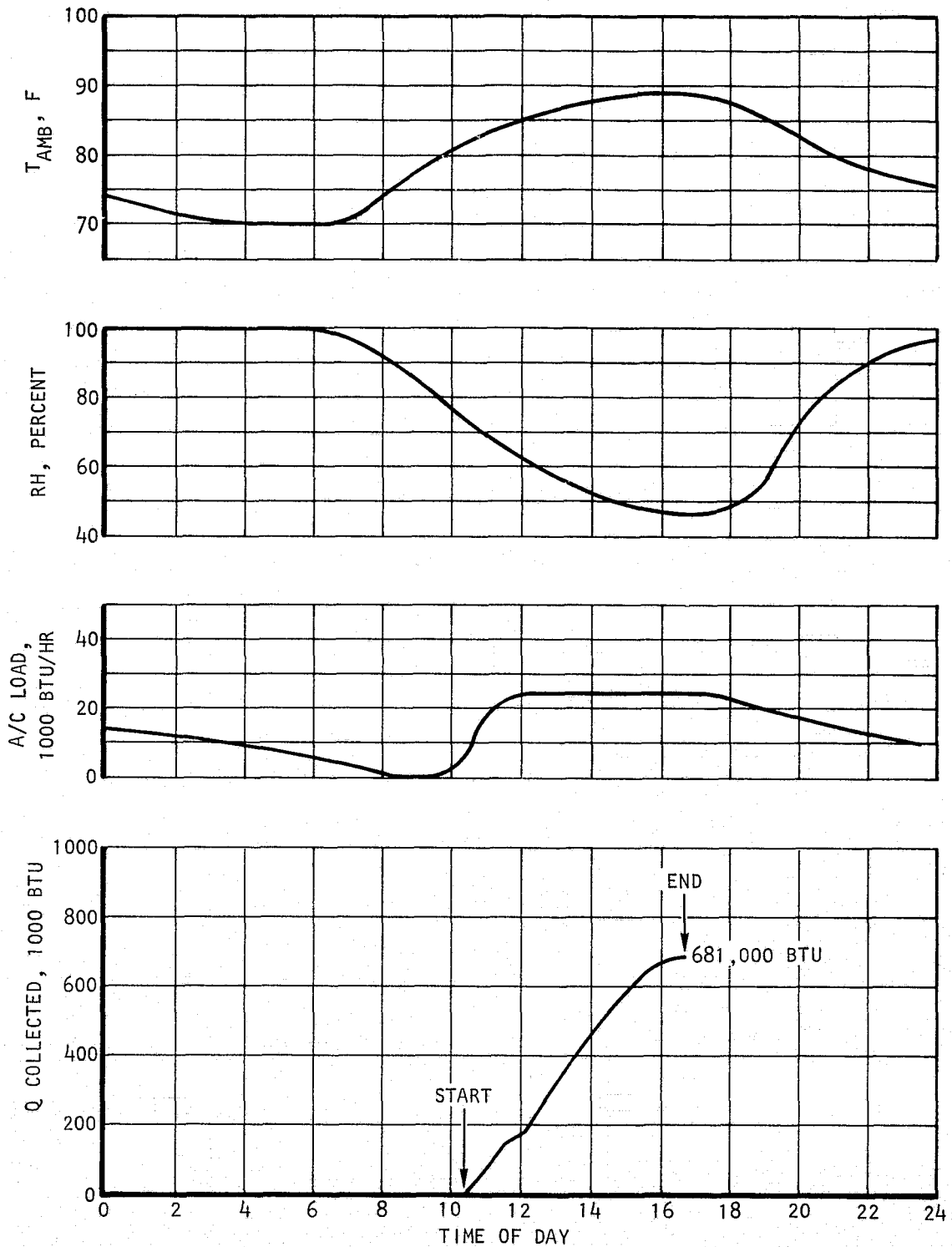

S-353

Figure 7-8. Solar House Data (8-23-74)



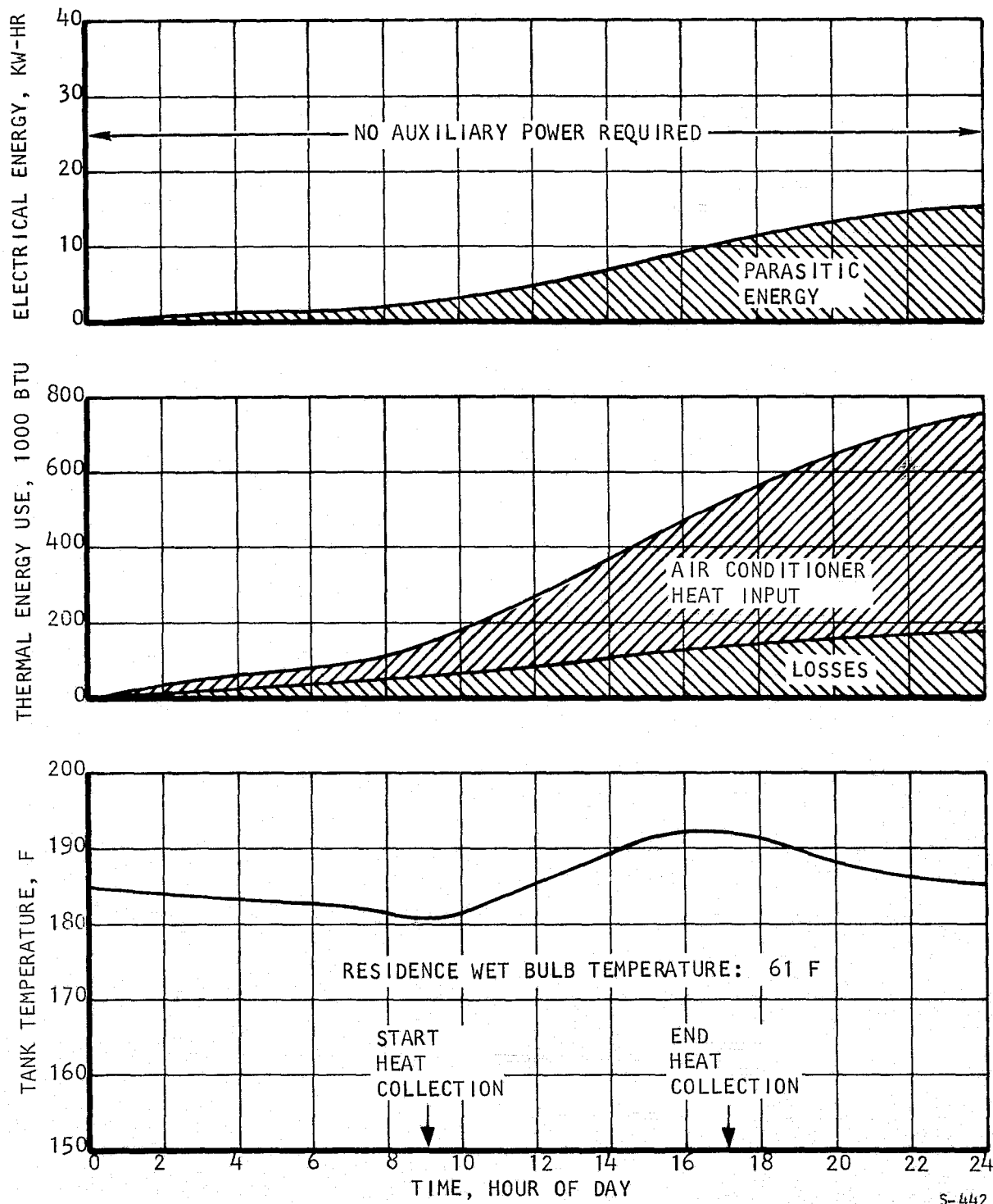

Figure 7-9. Rankine System Performance--NASA Solar House Simulation (August 19, 1974)

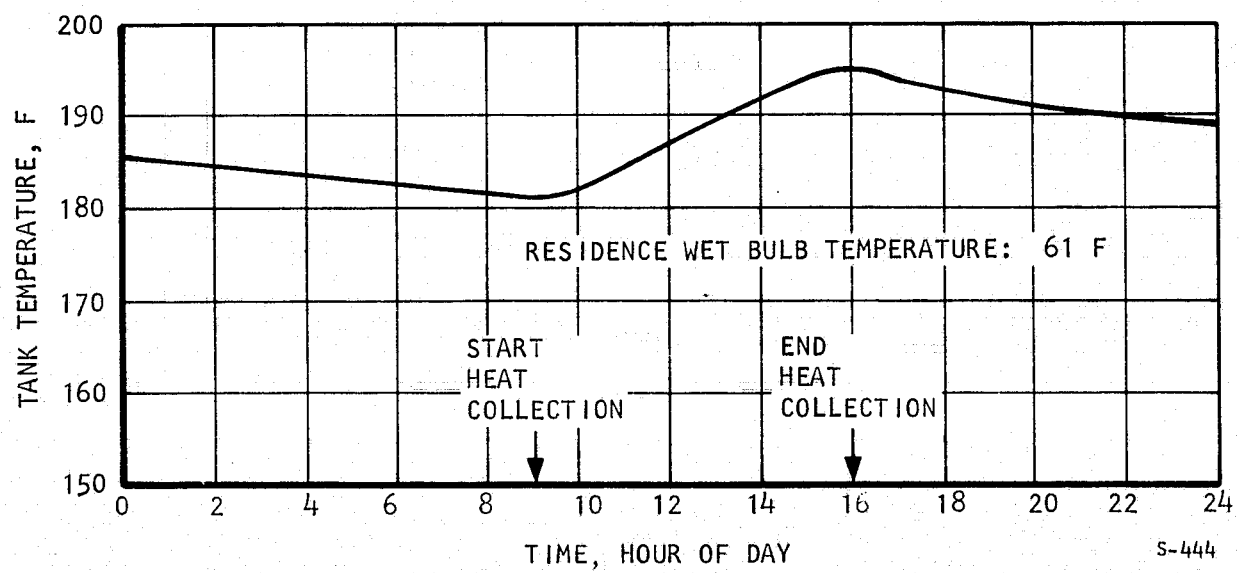
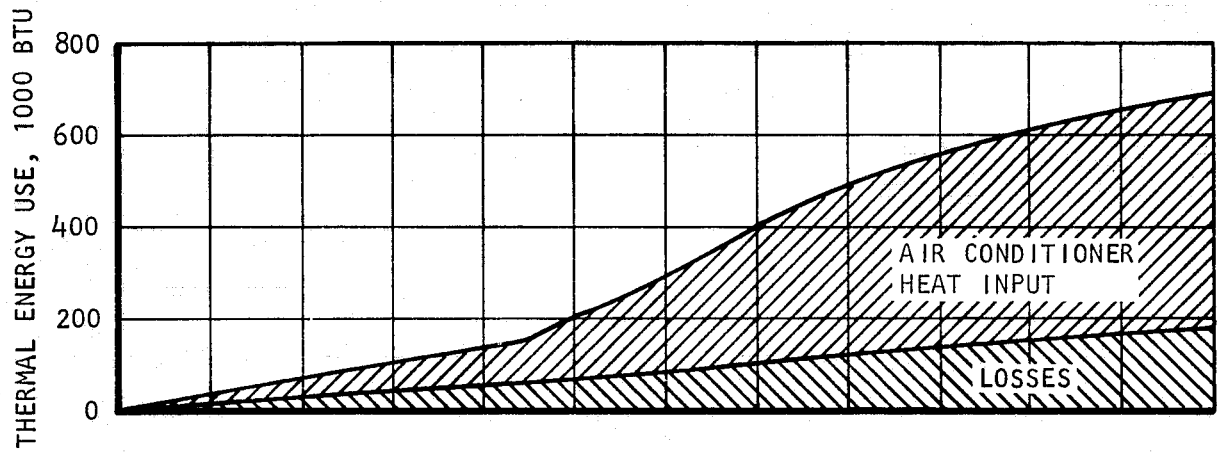
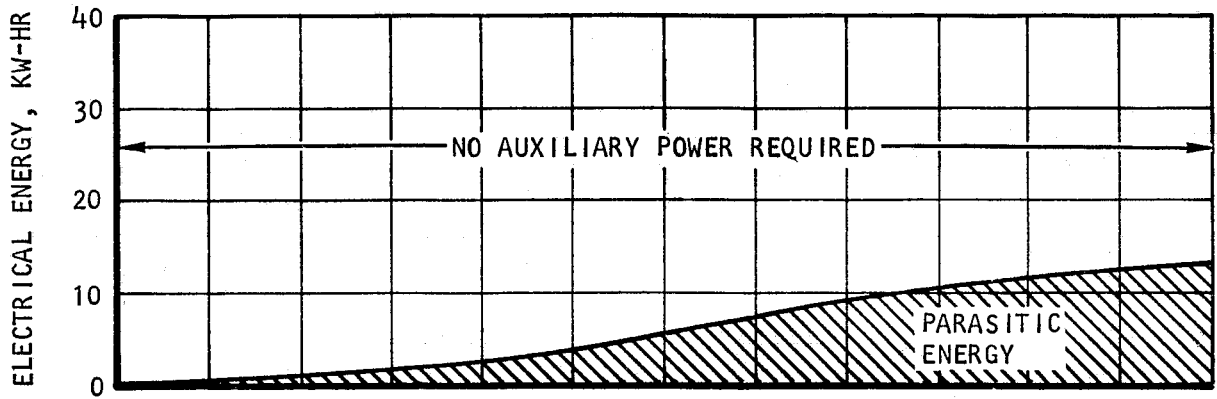

Figure 7-10. Rankine System Performance--NASA Solar House Simulation (August 20, 1974)



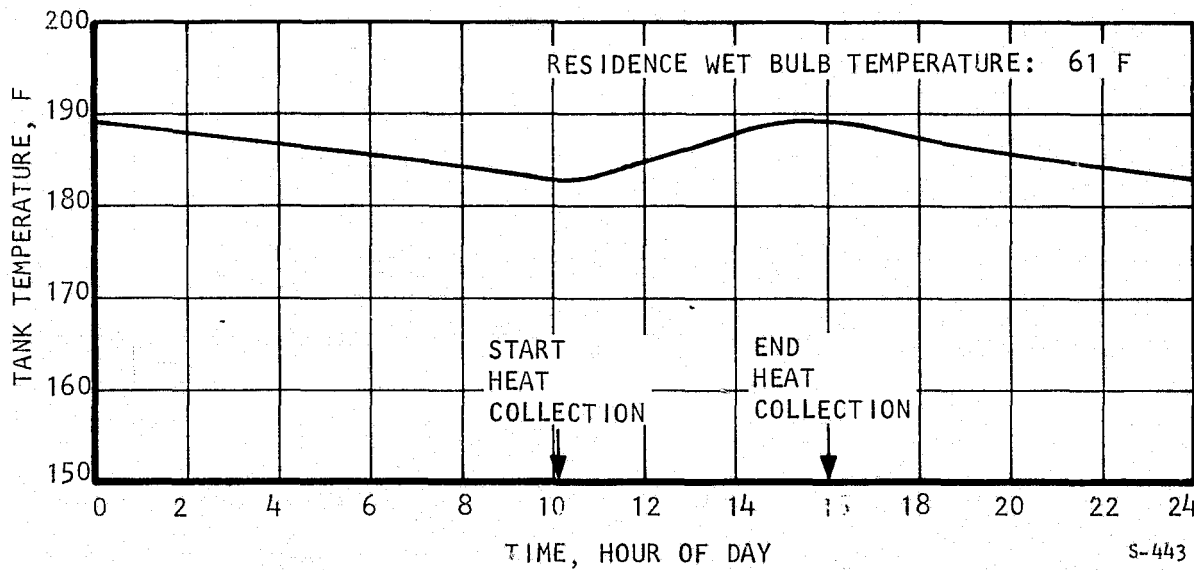
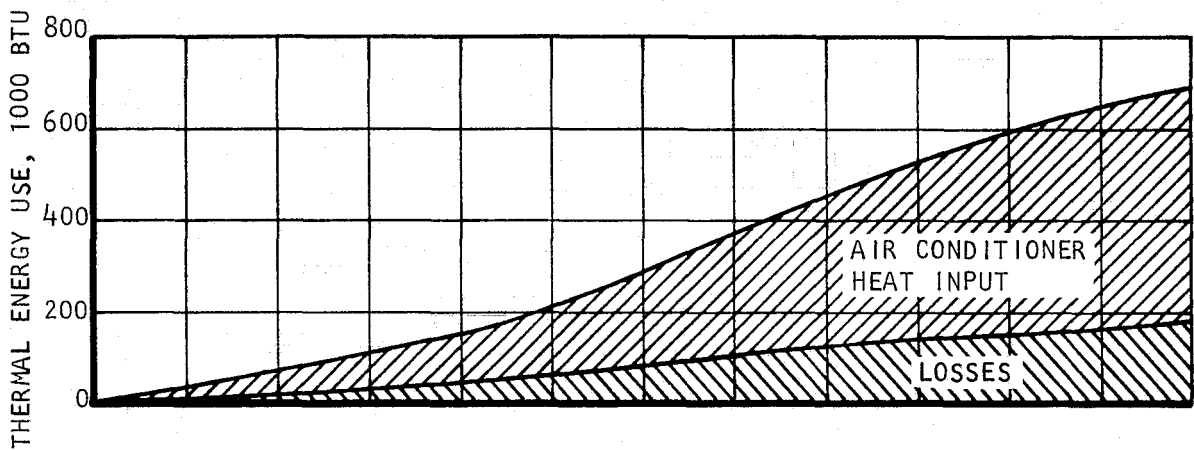
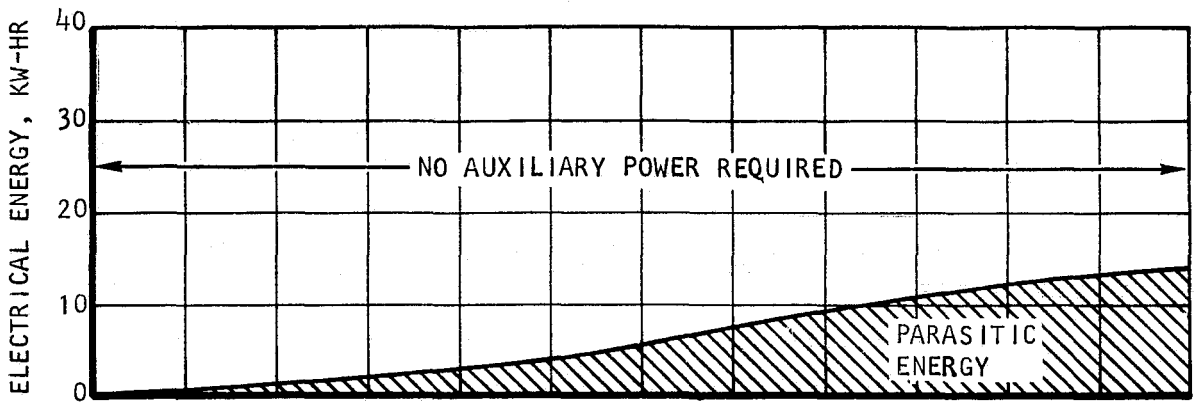

Figure 7-11. Rankine System Performance--NASA Solar House Simulation (August 21, 1974)



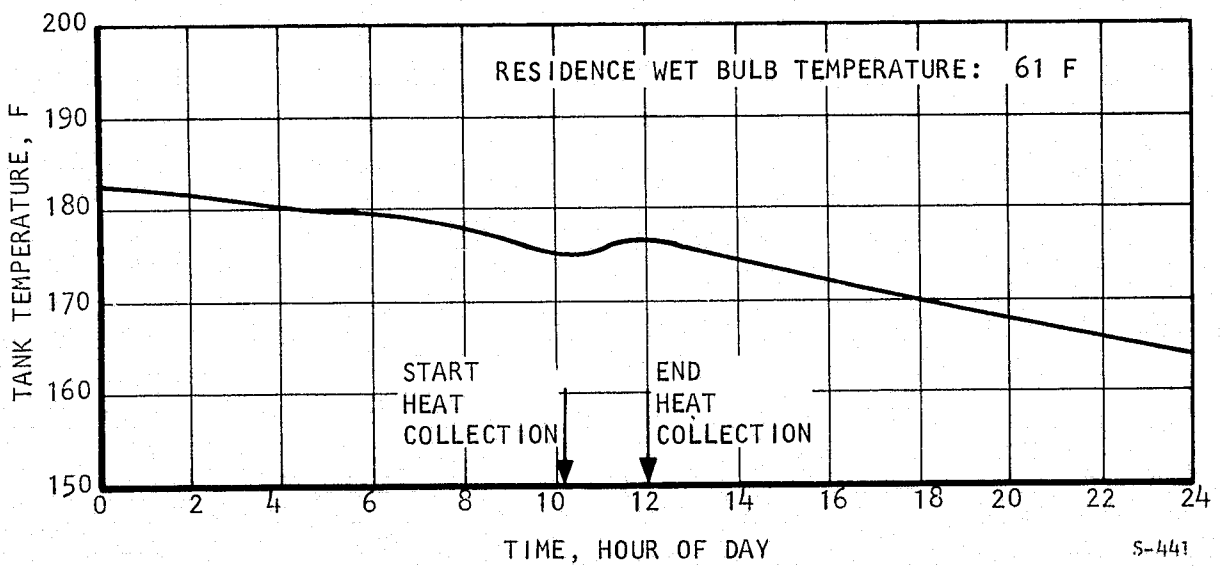
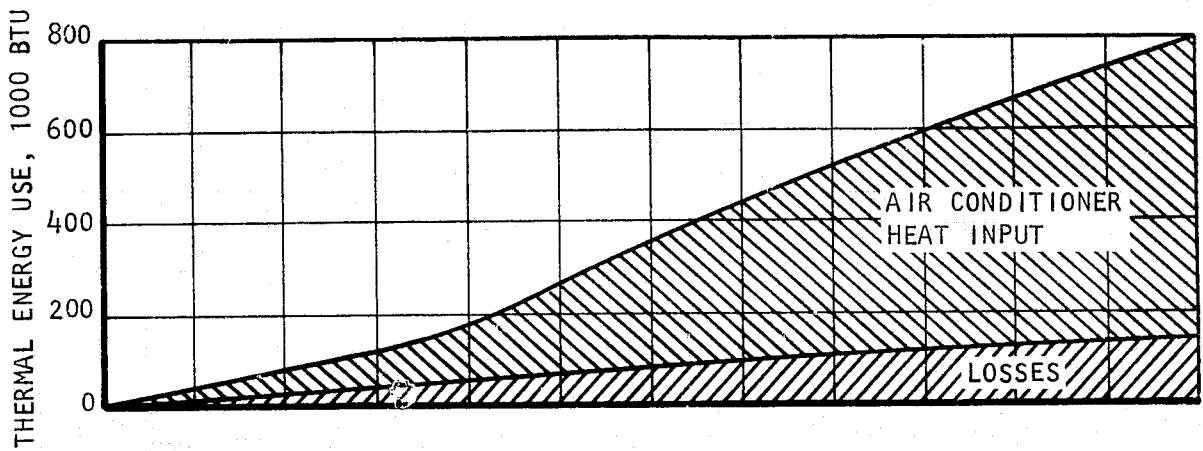
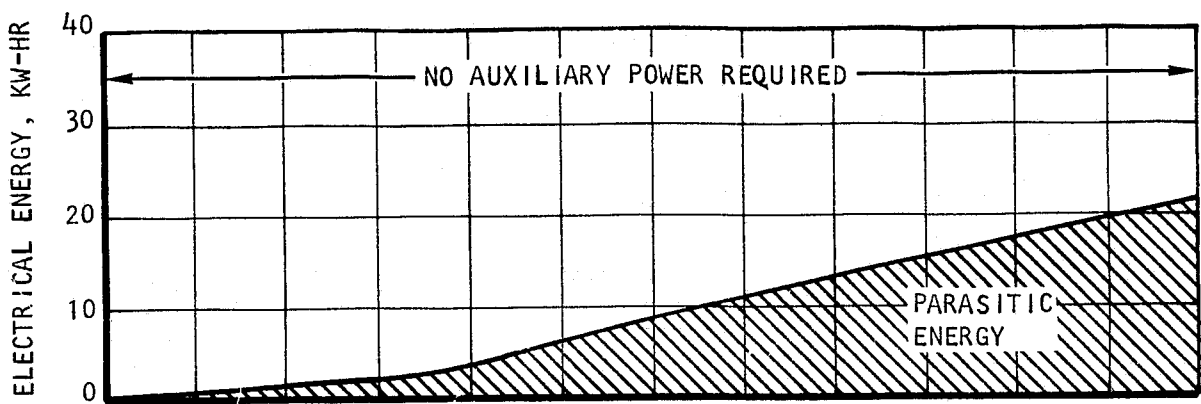
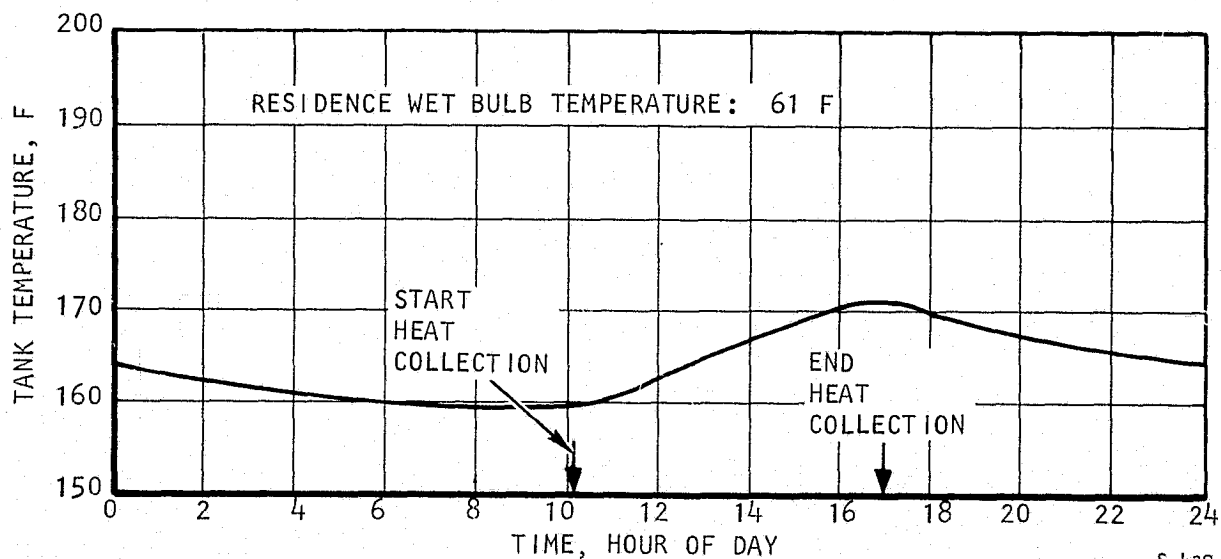
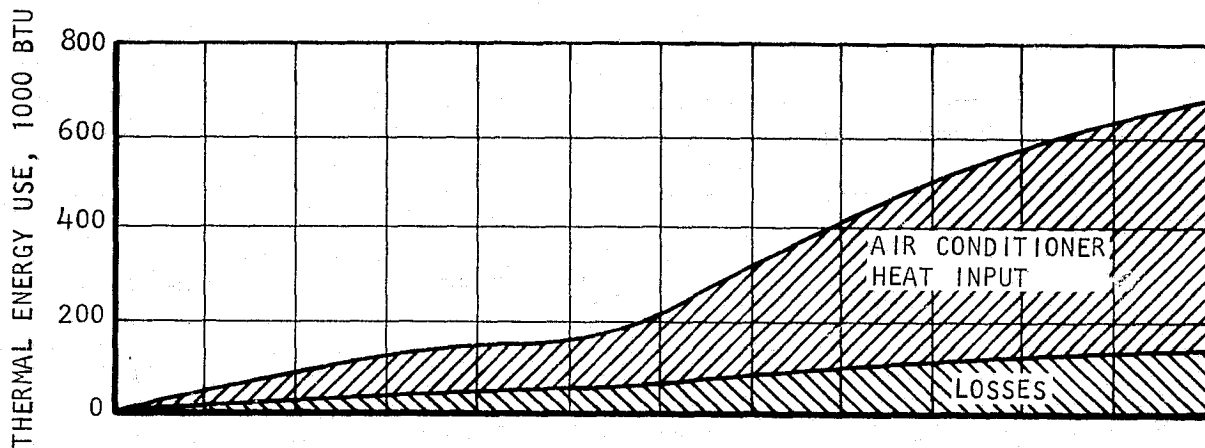
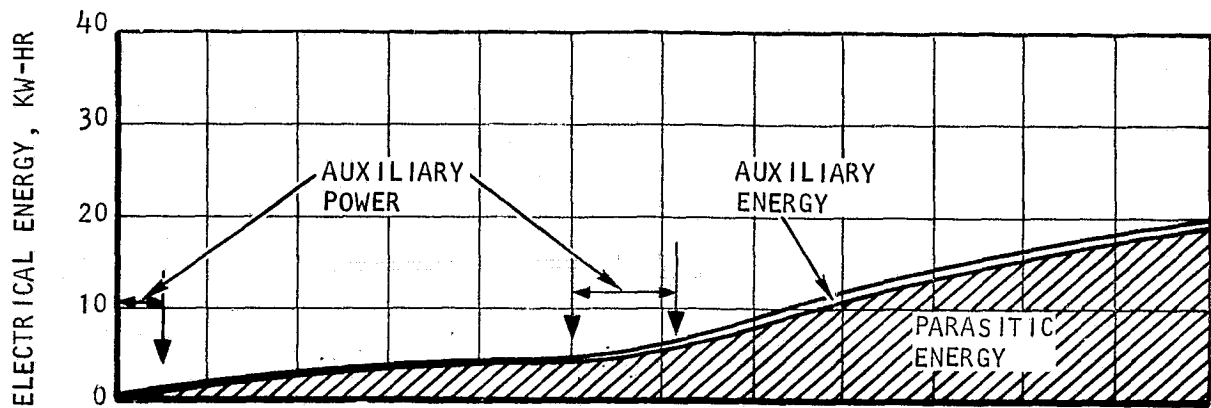

Figure 7-12. Rankine System Performance--NASA Solar House Simulation (August 22, 1974)





S-439

Figure 7-13. Rankine System Performance--NASA Solar House Simulation (August 23, 1974)



TABLE 7-1

NASA SOLAR HOUSE 5-DAY SIMULATION SUMMARY

Day	1	2	3	4	5	Total	Daily Average
Date--August 1974	19	20	21	22	23		
Air conditioning load, Btu	348,600	292,200	315,100	425,400	348,400	1,729,700	345,940
Q collected, Btu	778,000	805,000	478,000	150,000	681,000	2,892,000	578,400
Q losses, Btu	180,800	175,800	179,400	145,900	139,800	821,700	164,300
Q used by air conditioner, Btu	576,800	512,600	510,400	651,100	541,900	2,792,800	558,600
Tank temperature, F							
At 0 hr	185	185.7	189.0	182.7	164.2		
At 24 hr	185.7	189.0	182.7	164.2	164.2		
Average thermal COP	0.59	0.58	0.60	0.60	0.60		0.6
Electrical energy requirements, kw-hr							
Auxiliary energy	0	0	0	0	0.8	0.8	0.16
Parasitic energy	15.8	13.2	14.2	21.8	18.7	83.7	16.7
Total	15.8	13.2	14.2	21.8	19.5	84.5	16.9

The system heat losses (tank and pipes) represent 28 percent of the total energy collected. In system design, careful attention should be paid to this aspect of thermal management to increase the effectiveness of the entire system.

The data in Figure 7-2 indicate clearly that under the conditions prevailing during the 5-day period investigated the LiBr/H₂O absorption system would perform very poorly. This is evidenced by comparing the data of Figures 7-9 through 7-13 with the data contained in the NASA test data records for these 5 days.



SECTION 8

OPERATION IN THE HEAT PUMP MODE

GENERAL

Preliminary studies were performed to define the modifications necessary for operation of the system as a heat pump and also to evaluate its performance. In the heating mode, the Rankine power loop is deactivated and the auxiliary motor is used to drive the refrigeration loop compressor.

SYSTEM MODIFICATIONS

Figure 8-1 depicts the modified system in the cooling and heating modes of operation. The schematic was prepared for the case where a cooling tower is used as the ultimate heat sink in the cooling mode. With an evaporative condenser an R-11-to-water heat exchanger would have to be added to the system in parallel with the evaporative condenser. This heat exchanger would not be used in the cooling mode and would require isolation.

The system modifications necessary for dual mode operation include:

- (a) Addition of selector valves in the water lines from the hot water storage tank. These valves control the flow of water either to the boiler (cooling mode) or to the R-11/water heat exchanger (heating mode).
- (b) Addition of isolation shutoff valves in the Rankine power loop.
- (c) Addition of shutoff valves to isolate the cooling tower in the heating mode.
- (d) Addition of a switchover valve to assure reversal of the refrigerant flow in the compressor circuit.
- (e) Addition of dual expansion valve-check valve in the refrigerant line between the two-loop heat exchanger. These valves are necessary to switch the condenser-evaporator functions.
- (f) Addition of a receiver for fluid inventory control.

Other modifications involve resizing equipment already included in the baseline system, namely the auxiliary motor, the indoor coil size, and the conditioned space recirculation fan.

Early in the investigations it became apparent that (1) the air flow rate through the indoor coil had to be increased, and (2) the capacity of the indoor coil itself had to be increased for operation in the heating mode. These modifications had to be incorporated to permit handling of much larger heat loads at reduced heat transfer coefficient on the air side of the unit; in the air conditioning mode, humidity condensation occurs on the



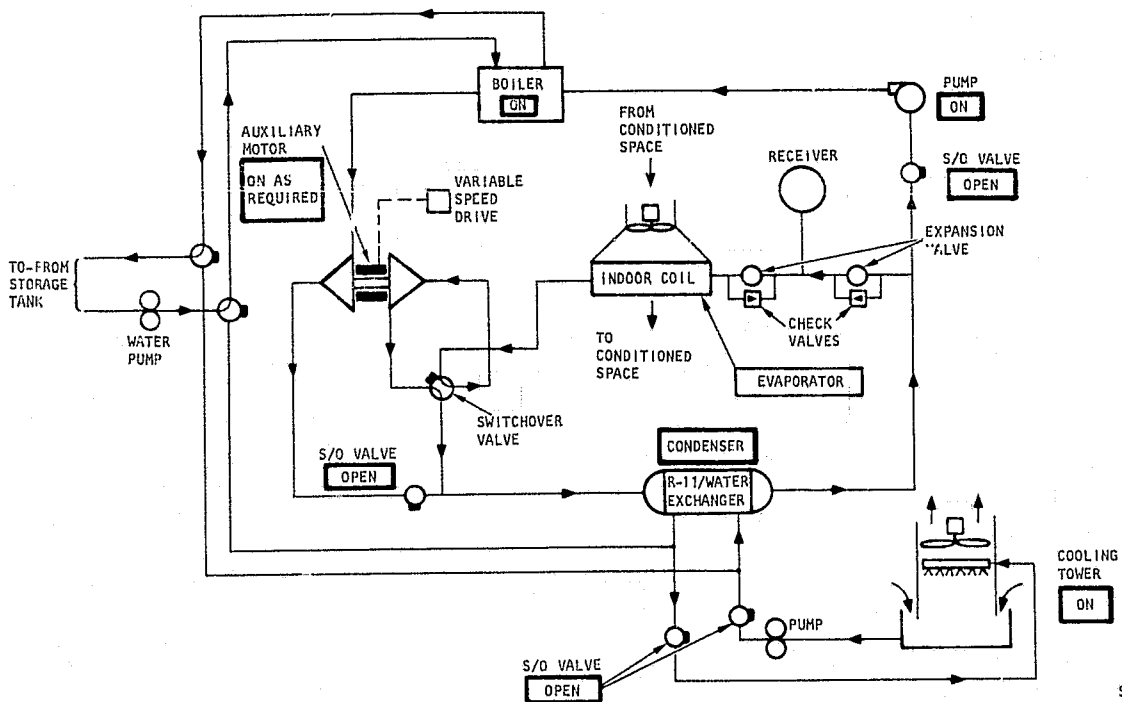

S-211

COOLING MODE

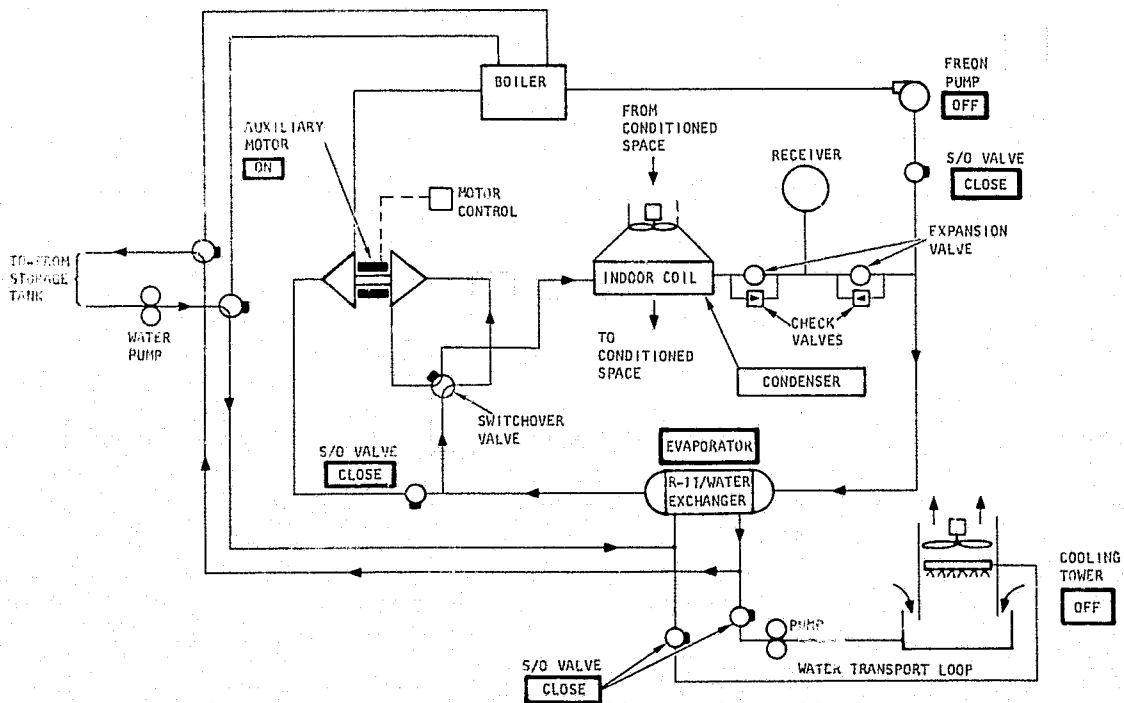

HEATING MODE

Figure 8-1. Heat-Powered Rankine Air Conditioner--Cooling and Heating Modes

extended surface of the evaporator. In the heating mode, the same heat exchanger operating as a condenser will be completely dry.

The return air flow from the conditioned space was increased from 0.4 to 0.57 m³/sec (850 to 1200 cfm). The face area of the heat exchanger was increased from 0.160 to 0.226 m² (1.73 to 2.44 ft²), and the number of tube rows was increased from 8 to 9.

HEAT PUMP PERFORMANCE

Parametric data were generated to cover the range of conditions defined by the following:

- (1) Heating capacity: 17.6, 23.4, and 29.3 kw (60,000, 80,000, and 100,000 Btu/hr)
- (2) Water temperature from the solar heat source: 288.9, 300, and 311.1 K (60, 80 and 100 F)
- (3) Residence temperature: 294.4 K (70 F)

Figure 8-2 is a plot of the heat pump capacity and COP as a function of water source temperature. Operation with low water source temperature is limited by the maximum speed of the compressor selected as 76,000 rpm. A turbocompressor could be designed for operation at higher speeds, thus extending the utility of the system. However, at higher speeds system COP will drop rapidly due to the low turbine and compressor efficiencies. Figure 8-3 shows the compressor operating line for a water heat source temperature of 311.1 K (100 F).

Since the system motor is operated at constant speed (63,000 rpm), the system capacity can be determined as a function of heat source temperature. To enhance capacity, compressor speed could be increased to 70,000 rpm by providing the necessary electronic circuitry in the frequency converter.

With a machine of this type, minimum power usage will be achieved if the speed of the compressor can be adjusted to provide maximum COP at any operating point. A variable speed motor could be used to control speed using residence temperature and water heat source temperature as the input signals.



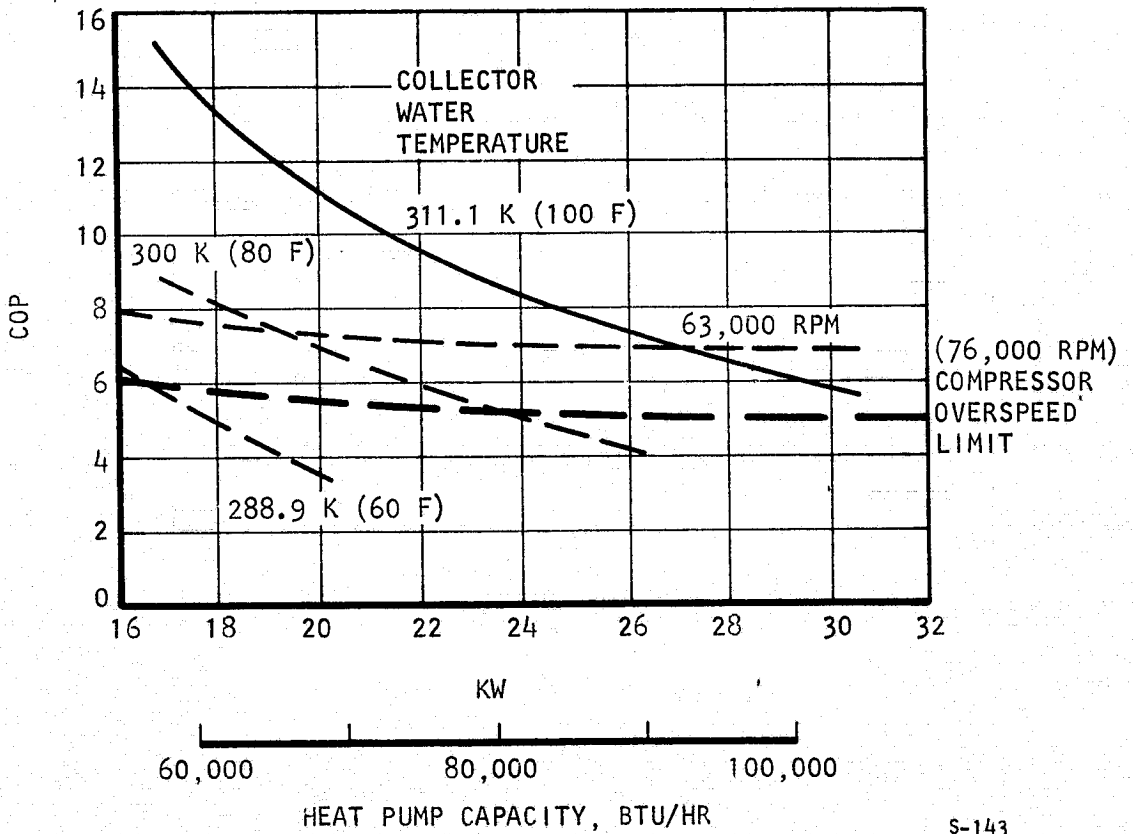
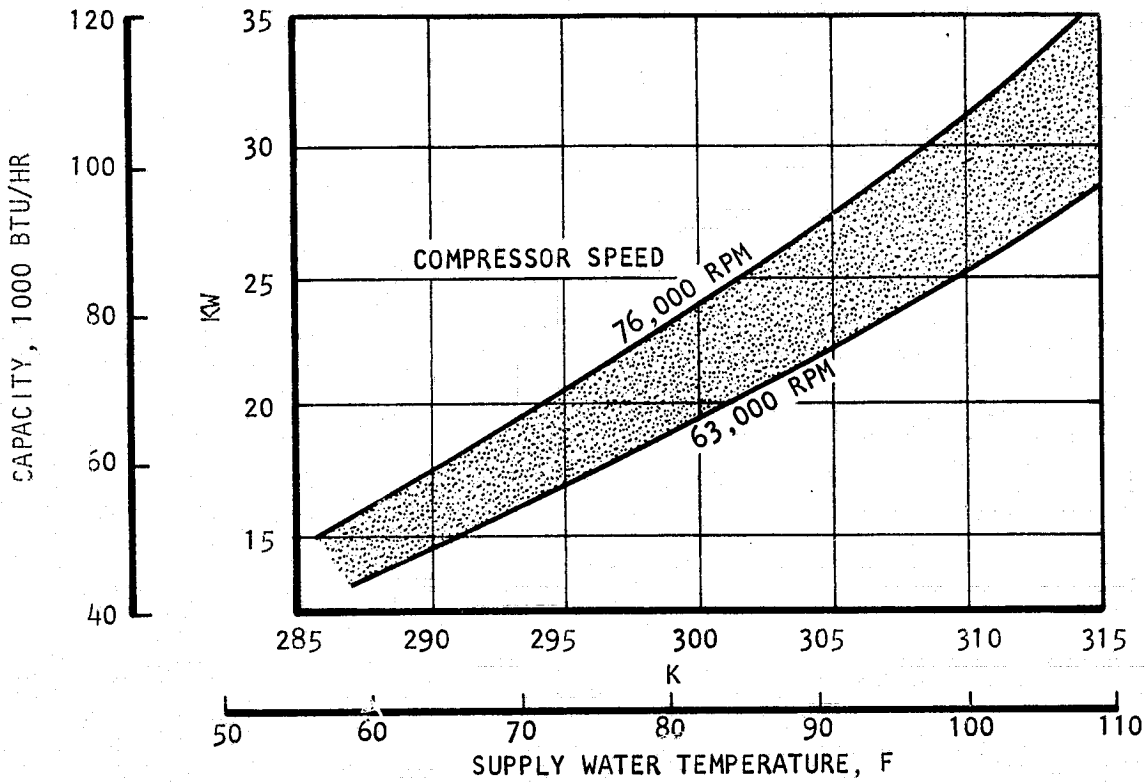

S-143

Figure 8-2. Performance in the Heat Pump Mode



2-2

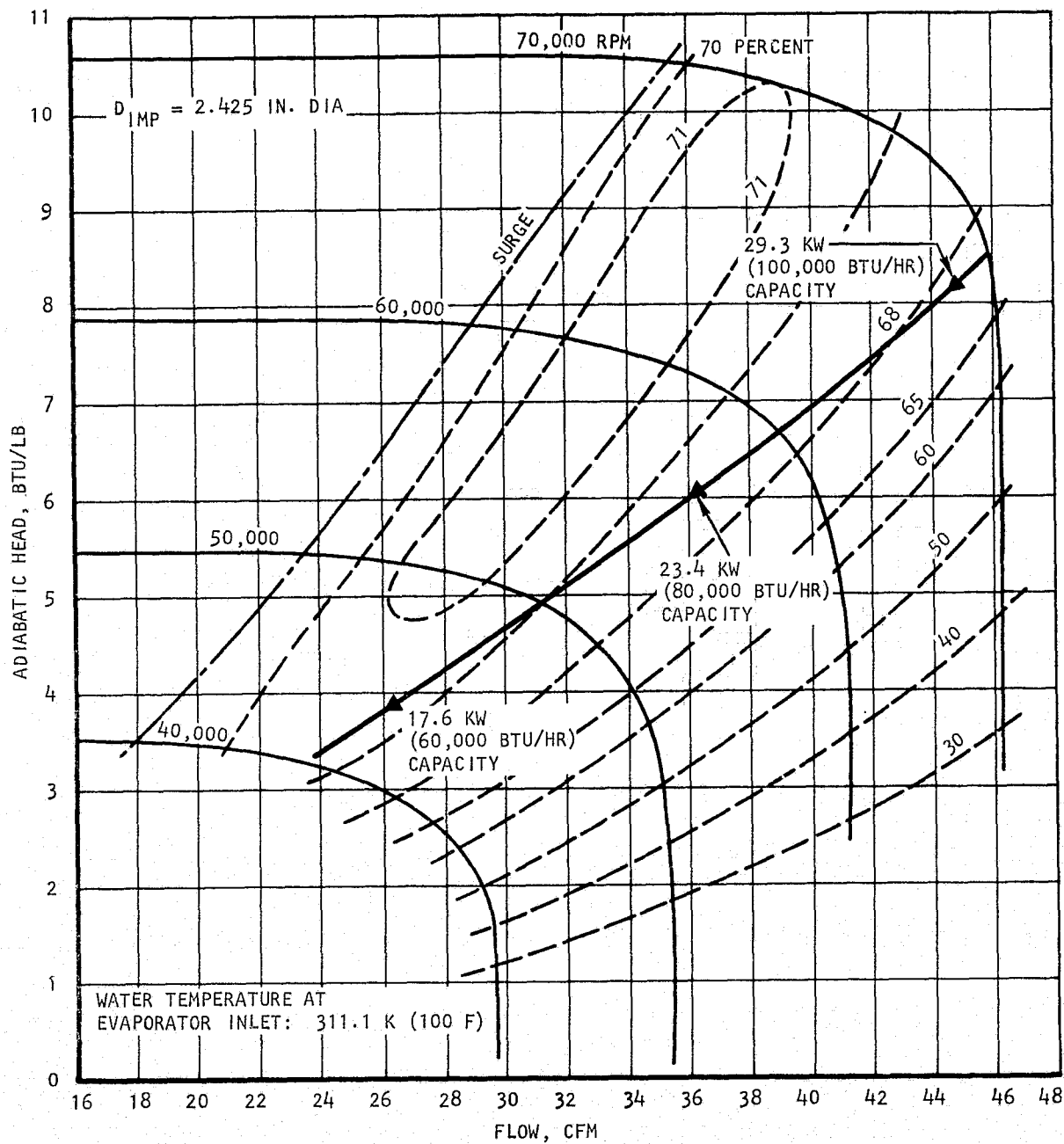

S-145

Figure 8-3. Typical Compressor Operating Line



APPENDIX A

OFF-DESIGN COMPUTER PROGRAM

This appendix contains a definition of the input data nomenclature for the off-design performance computer program. Also given are examples of input and output data.

Two versions of the program were prepared, corresponding to (1) operation in the non-augmented mode, and (2) operation in the augmented mode. The two programs are identified as SENSTY and POWRC respectively. Complete listings for these two programs have been supplied to NASA under separate cover.

Note that the two programs use the same input data. The major portion of the input data is contained in the namelist INPUT, which has been documented in AiResearch report 74-10996(7) previously submitted to NASA and is repeated here as Table A-1 for completeness. Other input data used by the computer are defined in Table A-2. Figure A-1 is a printout of the namelist INPUT data, and in Figure A-2 the additional input parameters are identified on the data statements of cards 201, 202, and 203 and "do loop" cards 210, 211, and 212.

Examples of output data are shown in Figures A-3 and A-4 for the non-augmented and augmented cases.



TABLE A-1
INPUT DATA NOMENCLATURE FOR 'RANKIN'

VIST	Viscosity of refrigerant at 15 tabulated temperatures TT, centipoise
TT	15 temperatures at which viscosity VIST is given, °F
TTH	17 temperatures at which following saturated liquid and vapor properties are given, °F
HVT	Enthalpy of saturated vapor at temperatures TTH, Btu/lb
HLT	Enthalpy of saturated liquid at temperatures TTH, Btu /lb
PT	Saturation pressure at temperatures TTH, psia
RHOVT	Density of saturated vapor at temperatures TTH, lb/(cu ft)
CP	Specific heat of vapor at constant pressure, Btu/(°F)(lb)
GAMMA	Specific heat ratio of vapor
AK	Ratio of sonic velocity to square root of absolute temperature, ft/(sec) ($\sqrt{^{\circ}R}$)
MW	Molecular weight of refrigerant
DPP	HX pressure drop expressed as a fraction of inlet pressure
EFM	Mechanical efficiency of turbocompressor shaft, in fraction
QR	Refrigeration load, Btu/hr
RHOL	Liquid density, lb/(cu ft)
EFPUMP	Efficiency of liquid pump, in fraction



TABLE A-1 (Continued)

TITLE	Name of refrigerant
NTB	Number of boiler temperatures to be used (maximum of 8 allowed)
TBT	Boiler temperatures to be used, °F
NTC	Number of condenser temperatures to be used (maximum of 8 allowed)
TCT	Condenser temperatures to be used, °F
NTE	Number of evaporator temperatures to be used (maximum of 8 allowed)
TET	Evaporator temperatures to be used, °F
KCR	Control index for the type of condenser employed; 1 for dry condenser, 2 for wet condenser, 3 for condenser using a prehumidifier, 4 for water-cooled condenser in conjunction with a cooling tower
UAER	UA per sq ft front area for a dry condenser, Btu/(hr)(°F)(sq ft)
EFFAN	Fan efficiency (combined aerodynamic and electrical)
CPL	Specific heat of liquid refrigerant, Btu/(lb)(°F)
TG	Air temperatures at evaporator inlet, outlet, condenser inlet and outlet respectively, °F
TW	Wet bulb temperatures of air at evaporator inlet, outlet, condenser inlet and outlet respectively, °F
NDTE	Number of evaporator approach temperatures to be used (maximum of 5 allowed)
DTET	Evaporator approach temperatures to be used, °F
NTDB	Number of boiler temperatures to be used (maximum of 5 allowed)
DTBT	Boiler temperatures to be used, °F
NDTC	Number of condenser temperatures to be used (maximum of 5 allowed)
DTCT	Condenser temperatures to be used, °F
NTBIN	Number of boiler inlet hot water temperatures to be used (maximum of 5 allowed)
TBINT	Boiler inlet hot water temperatures to be used, °F
NTCIN	Number of condenser inlet cooling water temperatures to be used for the case KCR = 4 (maximum of 5 allowed)
TCINT	Condenser inlet cooling water temperatures to be used, °F



TABLE A-2

INPUT DATA FOR OFF-DESIGN PROGRAM

Program Name:

SENSY

Namelist INPUT:

Input data for the design program RANKIN as defined earlier (Table A-1)

Built-In Data:

Operating conditions to be varied are built into the program. These are:

TW1T: Interior wet bulb temperature, F (5 allowed)

TBT: Hot water temperature at boiler inlet, F (8 allowed)

TW3T: Ambient dry bulb temperature, F (4 allowed)

Note: The above variables are systematically varied by use of 3 do-loops controlled by N6, N7, and N8.





AIR RESEARCH MANUFACTURING COMPANY
OF CALIFORNIA

SOLAR POWERED AIR CONDITIONING SYSTEM USING R-11
NET CONDENSER EMPLOYED

```

$INPUT
VTST = .95000000+02, .10250000+01, .11000000+01, .11600000+01,
       .12250000+01, .12820000+01, .13400000+01, .13900000+01,
       .00000000+00, .00000000+00, .00000000+00, .00000000+00,
       .00000000+00, .00000000+00, .00000000+00, .00000000+00,
TT = .00000000+00, .40000000+02, .80000000+02, .12000000+03,
     .16000000+03, .20000000+03, .24000000+03, .28000000+03,
     .40000000+02, .20000000+03, .00000000+00, .20000000+02,
     .40000000+02, .60000000+02, .80000000+02, .10000000+03,
     .12000000+03, .14000000+03, .16000000+03, .18000000+03,
     .20000000+03, .22000000+03, .24000000+03, .26000000+03,
     .28000000+03,
HVT = .87529999+02, .89949999+02, .92419999+02, .94889999+02,
     .97389999+02, .99879999+02, .10235999+03, .10489999+03,
     .10721999+03, .10958999+03, .11187999+03, .11406999+03,
     .11616999+03, .11812999+03, .11991999+03, .12151999+03,
     .12284999+03,
HLT = .00000000+00, .39800000+01, .79899999+01, .12030000+02,
     .16120000+02, .20270000+02, .24480000+02, .28750000+02,
     .33080000+02, .37480000+02, .41950000+02, .46470000+02,
     .51070000+02, .55760000+02, .60530000+02, .65459999+02,
     .70569999+02,
PT = .73869999+00, .14190000+01, .25540000+01, .43419999+01,
     .70299999+01, .10910000+02, .16310000+02, .23600000+02,
     .33180000+02, .45500000+02, .61010000+02, .80179999+02,
     .10352999+03, .13158000+03, .16487000+03, .20397000+03,
     .24947000+03,
RHOVT = .22600000+01, .41539999+01, .71709999+01, .11739999+00,
     .16350000+00, .27590000+00, .40100000+00, .56630000+00,
     .78009999+00, .10520000+01, .13920000+01, .18140000+01,
     .23350000+01, .29680000+01, .37440000+01, .46960000+01,
     .58800000+01,
CP = .14000000+00,
GAMMA = .11100000+01,
AK = .19800000+02,
MB = .13740000+03,
DPP = .49999999+01, .49999999+01, .49999999+01, .49999999+01,
     .49999999+01, .49999999+01, .49999999+01, .49999999+01,
     .49999999+01, .49999999+01, .49999999+01, .49999999+01,
     .49999999+01, .49999999+01, .49999999+01, .49999999+01,
EFM = .39999999+00,
QR = .36000000+05,
HFOI = .91000000+02,
EFPUMP = .50000000+00,
TITLE = .25618020+18,
NTB = .1,
TBT = .18500000+03, .18500000+03, .18000000+03, .19000000+03,
     .00000000+00, .00000000+00, .00000000+00, .00000000+00,
NTC = .1,
TCT = .90000000+02, .11500000+03, .12000000+03, .12500000+03,
     .00000000+00, .90000000+00, .00000000+00, .00000000+00,
NTE = .1,
TET = .45000000+02, .50000000+02, .00000000+00, .00000000+00,
     .00000000+00, .00000000+00, .00000000+00, .00000000+00,
KCR = .2,
UAER = .11830000+03,

```

Figure A-1. Example of Input Data--Namelist INPUT



RESEARCH MANUFACTURING COMPANY
OF CALIFORNIA

EFFAN	=	.89000000+01			
CPL	=	.21000000+01			
IG	=	.80000000+01	.00000000+00	.95000000+02	.00000000+00
TK	=	.75000000+02	.00000000+00	.75000000+02	.00000000+00
NDTE	=	.10000000+01			
DYET	=	.15000000+02	.75000000+01	.20000000+02	.12500000+02
NDTR	=	.15000000+02			
DYRT	=	.75000000+01	.10000000+02	.15000000+02	.00000000+00
NDTL	=	.00000000+00			
DYCT	=	.10000000+02	.15000000+02	.00000000+00	.00000000+00
NTBIN	=	.00000000+00			
TRIAI	=	.20000000+03	.00000000+00	.00000000+00	.00000000+00
NTCIN	=	.00000000+00			
TCIAT	=	.80000000+02	.65000000+02	.00000000+00	.00000000+00
SEND		.00000000+00			

Figure A-1 (Continued)



```

00424 163* 51 (LM/HK) IN OUT (DEG F) HX FAN HX FAN1/
00425 164* WRITE(6,98)G,TG(1),TG(2),W(5),T(5),T(1),UAE,WTE,WTFE,COSTE,FANCE,
00425 165* 1 DPET,POWRFE
00425 166* 1,F(1),T(1),T(2)
00447 167* WRITE(6,99) *SAMPB IN TROUT,W(6),T(6),T(7),UAE,KTB,ZR,COSTH,ZR,
00447 168* 1Z,F(2),T(2)
00467 169* WRITE(6,102)W(3),T(3),T(4),GC,TGC,TG4,UAS,WTC,WTFE,COSTC,
00467 170* 1FANCO,LPCOT,POWRFC,W(3),T(3),T(4)
00511 171* 98 FORMAT(1,EVAPI
00511 172* 1T10,F8.0,F8.1,F7.1,F8.0,F7.1,F6.1,F9.2,4F7.1,F4.2,F10.1,F11.0,
00511 173* 2F7.1,F8.1)
00512 174* 99 FORMAT(1,BOILEFI
00512 175* 1T10,F8.0,F8.1,F7.1,F8.0,F7.1,F6.1,F9.2,4F7.1,F4.2,F10.1,F11.0,
00512 176* 2F7.1,F8.1)
00513 177* 102 FORMAT(1,CONDNSR1
00513 178* 1T10,F8.0,F8.1,F7.1,F8.0,F7.1,F6.1,F9.2,4F7.1,F4.2,F10.1,F11.0,
00513 179* 2F7.1,F8.1)
00513 180* WRITE(6,104)
00513 181* 104 FORMAT(///) COEF OF PERFORMANCE!,T30,'TURBO-COMPRESSOR!,T60,'ELECT
00516 182* 1RIC POWER HEAD(WATT)!, T90,'SYSTEM COST(S)!' )
00517 183* WRITE(6,105)PCUP,PC,POWRFE,COSTF
00525 184* 105 FORMAT(1,POWER COP!,T15,F8.3,T30,'COMPR DIA(IN)!' ,T45,F8.3,
00525 185* 2T60,'EVAP FAN!,T75,F8.3,T90,'FACTORY COST ',T105,F8.0)
00526 186* WRITE(6,106)XCUP,EFCF,POWRFC
00533 187* 106 FORMAT(1,REFRIG COP!,T15,F8.3,T30,'COMPR EFF!,T45,F8.3, T60,'CONDNS
00533 188* 1R FAN!,T75,F8.3)
00534 189* WRITE(6,107)COP,NC,POWRCT,COSTU
00542 190* 107 FORMAT(1,SYSTEM COP!,T15,F8.3,T30,'RPM!,T45,F8.0,T60,'CL TOWER FAN
00542 191* 1!,T75,F8.3,T90,'USER COST!',T105,F8.0)
00543 192* WRITE(6,108)UT,POWRAP
00547 193* 108 FORMAT(T30,'TURBN DIA(IN)!',T45,F8.3,T60,'WATER PUMP!,T75,F8.3)
00550 194* WRITE(6,109)EFT,PMWLP
00554 195* 109 FORMAT(T30,'TURBN EFF!',T45,F8.3,T60,'FREUN PUMP!,T75,F8.3)
00555 196* WRITE(6,110)PTUT
00560 197* 110 FORMAT(T60,'TOTAL!',T75,F8.3)
00561 198* RETURN
00562 199* SUBROUTINE OFFDSM
00565 200* DIMENSION IWT(5),T(8),TWST(4)
00566 201* DATA IWT/58.,61.,64.,67.,70./
00572 202* DATA TWT/160.,170.,180.,190.,200.,210.,220.,230./
00572 203* DATA TWT/65.,70.,75.,80./
00574 204* DIMENSION NSEQX(10),NSEQCL(10)
00575 205* DATA NSEQX/1,2,3,4,5,6,7,8,9,10/
00577 206* DATA NSEQCL/ 1,2,3,4,5,6,7,8,9,10/
00601 207* CONVE=0.075
00602 208* IPRT=0
00603 209* NITER=13
00604 210* DO 11 I=1,4
00607 211* DO 11 J=2,7
00612 212* DO 11 K=1,4
00615 213* TH1=TWST(NO)
00616 214* TR1=TWST(T7)
00617 215* T4(3)=TWST(NO)
00620 216* T(7)=TH1-15.0
00621 217* T(4)=T4(3)+15.0
00622 218* XEQ(1)= (1)
00623 219* XEQ(2)=NC
00624 220* XEQ(3)=T(7)
00625 221* XEQ(4)=T(-)
00626 222* NQUE =2

```

```

*NEW
*NEW
*NEW
*NEW
*NEW
*NEW
**1
*NEW
*NEW
*NEW
*NEW
*NEW
*NEW
*NEW

```

Figure A-2. Example of Input Data--Built-in Data



SOLAR POWERED AIR CONDITIONING SYSTEM USING
WET CONDENSER EMPLOYED

R=11
RUN ON 23 OCT 75 AT 10155107

STATION/ID	TEMPERATURE DEG F	PRESSURE PSIA	ENTHALPY BTU/LB	FLOW RATE LB/HR	DENSITY LB/CU FT
1	41.3005	7.2823	97.5519	407.1864	.1895
2	124.7319	20.4912	108.3107	407.1864	.4676
3	111.8332	20.4912	106.5413	997.6001	.4782
4	88.7941	19.5155	26.3575	997.6001	.0000
5	43.1774	7.6464	26.3575	407.1864	.0000
6	90.1811	79.3441	26.6446	590.4136	.0000
7	175.1860	75.5658	113.5429	590.4136	1.7124
8	101.2460	20.4912	105.3210	590.4136	.4986

HEAT EXCHANGER	HOT FLUID		COLD FLUID		UA		WEIGHT		COST		FAN DP	FAN POWER	Q	WET HULB(F)	
	FLC	TEMP(F)	FLC	TEMP(F)	(BTU/HR/	(DEG F)	HX	FAN	(US \$)	(IN=H2O)	(WATT)	(BTU/HR)	IN	OUT	
EVAP	3815.	80.0	55.0	407.	43.2	41.3	.00	35.8	32.6	27.2	42.7 .86	179.0	28989.	61.0	93.4
BOILER	6927.	190.0	182.6	590.	90.2	175.2	4801.57	35.5	.0	54.3	.0 .00	.0	51306.		
CONDNSR	996.	111.8	75.8	16242.	95.0	*****	.00	91.8	106.4	109.8	124.3 .82	631.0	79978.	75.0	79.6

COEF OF PERFORMANCE		TURBO-COMPRESSOR		ELECTRIC POWER REQD(WATT)		SYSTEM COST(\$)	
POWER COP	.045	COMPR DIA(IN)	2.425	EVAP FAN	178.997	FACTORY COST	822.
REFRIG COP	6.617	COMPR EFF	.702	CONDNSR FAN	830.980	USER COST	3055.
SYSTEM COP	.563	RPM	60705.	CL TOWER FAN	.000		
		TURBN DIA(IN)	1.766	WATER PUMP	87.562		
		TURBN EFF	.799	FREON PUMP	49.658		
				TOTAL	1147.197		

COMPRESSOR FLOW IN CFM = 35.81 ADIABATIC HEAD IN BTU/LB = 7.55

Figure A-3. Example of Output Data--Non-Augmented Mode



SOLAR POWERED AIR CONDITIONING SYSTEM USING R-11
 PET CONDENSER EMPLOYED RUN ON 28 OCT 75 AT 16136141

STATION/ID	TEMPERATURE DEG F	PRESSURE PSIA	ENTHALPY BTU/LB	FLOW RATE LB/HR	DENSITY LB/CU FT
1	39.4165	6.9516	97.5171	438.3401	.1216
2	123.6414	19.5533	108.5377	438.3401	.4461
3	114.8372	19.5533	107.0902	794.7156	.4531
4	86.3435	18.6222	25.8343	794.7156	.0000
5	41.3874	7.2992	25.8343	438.3401	.0000
6	88.6081	48.9269	26.3099	356.3754	.0000
7	141.4146	46.5970	109.7520	356.3754	1.0760
8	101.2480	19.5533	105.5559	356.3754	.4986

HEAT EXCHANGER	HOT FLUID		COLD FLUID		UA (BTU/HR/DEG F)	WEIGHT (LB)		COST (US \$)		FAN DP (IN=H2O)	FAN POWER (WATT)	Q (BTU/HR)	WET BULB(F)	
	FLOW (LB/HR)	TEMP(F) IN OUT	FLOW (LB/HR)	TEMP(F) IN OUT		HX	FAN	HX	FAN				IN	OUT
EVAP	3415.	80.0 55.0	438.	41.4 39.4	.00	35.8	32.6	27.2	42.7 .86		179.0	31334.	61.0	47.4
BOILER	6927.	150.0 145.7	356.	88.6 141.4	4801.57	35.5	.0	54.3	.0 .00		.0	29737.		
CONDNSR	795.	114.8 86.3	18242.	95.0*****	.00	91.8	108.4	109.8	124.3 .82		831.0	64573.	75.0	78.7

COEF OF PERFORMANCE		TURBO-COMPRESSOR		ELECTRIC POWER REQD(WATT)		SYSTEM COST(\$)	
POWER COP	.050	COMPR DIA(IN)	2.425	EVAP FAN	176.997	FACTORY COST	822.
REFRIG COP	6.486	COMPR EFF	.683	CONDNSR FAN	830.980	USER COST	3055.
SYSTEM COP	1.048	RPM	63000.	CL TOWER FAN	.000		
		TURBN DIA(IN)	1.766	WATER PUMP	87.502		
		TURBN EFF	.617	FREON PUMP	49.658		
				TOTAL	1147.197		

COMPRESSOR FLOW IN CFM = 40.24 ADIABATIC HEAD IN BTU/LB = 7.52
 ALAILIARY POWER IN WATTS = 775.14

Figure A-4. Example of Output Data--Augmented Mode

APPENDIX B

OVERALL SOLAR SYSTEM PROGRAM

The solar system computer program simulates the performance of the system shown in Figure 7-1. The name of the program is TRANST.

The input data for TRANST includes the input data for the design program RANKIN defined previously in Table A-1 and Figure A-1. In addition, the system program inputs include namelist TRANS defining the transient data input; these are defined in Table B-1. Figure B-1 is a listing of the data input corresponding to the August 20, 1974 data and a residence wet bulb temperature of 291.1 K (64 F).

An example of output data is shown in Figure B-2 for the same day from 11.05 to 13.75 hr.

A listing of the program has been submitted to NASA under separate cover.



TABLE B-1
INPUT DATA FOR SYSTEM PROGRAM

Program Name:

TRANST

Namelist INPUT:

Input data for the design program RANKIN as defined earlier (Figure A-1)

Namelist TRANS:

Transient data defining the system are inputted through namelist TRANS:

TIMET: Tabulated time of the day at which the following transient variables are given, hr (total of 25 allowed)

QCOLT: Solar collector heat collection rates tabulated against TIMET, Btu/hr

Q1T: Air conditioning loads tabulated at TIMET, Btu/hr

WTA: Ambient wet bulb temperatures tabulated at TIMET, F

TG3T: Ambient dry bulb temperatures tabulated at TIMET, F

TW1: Desired wet bulb temperature in the air conditioned chamber, F

DTS: System time increment, hr

TTOUT: Initial water tank temperature, F



SOLAR POWERED AIR CONDITIONING SYSTEM USING R-11
WFT CONDENSER EMPLOYED

SINPUT				
VIST	1			
	.9500000+02.	.1025000+01.	.1100000+01.	.1160000+01.
	.1225000+01.	.1282000+01.	.1340000+01.	.1390000+01.
	.0000000+00.	.0000000+00.	.0000000+00.	.0000000+00.
	.0000000+00.	.0000000+00.	.0000000+00.	.0000000+00.
TT	1			
	.0000000+00.	.4000000+02.	.8000000+02.	.1200000+03.
	.1600000+03.	.2000000+03.	.2400000+03.	.2500000+03.
TTF	1			
	.4000000+02.	.2000000+02.	.0000000+00.	.2000000+02.
	.4000000+02.	.6000000+02.	.8000000+02.	.1000000+03.
	.1200000+03.	.1400000+03.	.1600000+03.	.1800000+03.
	.2000000+03.	.2200000+03.	.2400000+03.	.2600000+03.
	.2800000+03.			
MVT	1			
	.8752999+02.	.8994999+02.	.9241999+02.	.9484999+02.
	.9736999+02.	.9987999+02.	.1023599+03.	.1048099+03.
	.1072199+03.	.1095699+03.	.1118799+03.	.1140699+03.
	.1161699+03.	.1181299+03.	.1199199+03.	.1215199+03.
	.1226499+03.			
HLT	1			
	.0000000+00.	.3980000+01.	.7989999+01.	.1203000+02.
	.1612000+02.	.2027000+02.	.2448000+02.	.2875000+02.
	.3308000+02.	.3748000+02.	.4195000+02.	.4647000+02.
	.5107000+02.	.5576000+02.	.6053000+02.	.6549999+02.
	.7056999+02.			
PT	1			
	.7386999+00.	.1419000+01.	.2554000+01.	.4341999+01.
	.7029999+01.	.1091000+02.	.1631000+02.	.2360000+02.
	.3318000+02.	.4550000+02.	.6101000+02.	.8017999+02.
	.1035299+03.	.1315600+03.	.1648700+03.	.2039700+03.
	.2494700+03.			
RHOVT	1			
	.2260000+01.	.4153999+01.	.7170999+01.	.1173999+00.
	.1835000+00.	.2759000+00.	.4010000+00.	.5663000+00.
	.7800999+00.	.1052000+01.	.1392000+01.	.1814000+01.
	.2333000+01.	.2968000+01.	.3744000+01.	.4696000+01.
	.5880000+01.			
CP	1			
GAMMA	1			
AK	1			
M+	1			
DPP	1			
	.1400000+00.			
	.1110000+01.			
	.1980000+02.			
	.1374000+03.			
	.4999999+01.	.4999999+01.	.4999999+01.	.4999999+01.
	.4999999+01.	.4999999+01.	.4999999+01.	.4999999+01.
	.4999999+01.	.4999999+01.	.4999999+01.	.4999999+01.
	.4999999+01.	.4999999+01.	.4999999+01.	.4999999+01.
	.8999999+00.			
EFM	1			
DF	1			
RHOL	1			
EFFUMP	1			
TITLE	1			
NTB	1			
TBT	1			
	.1850000+03.	.1950000+03.	.1800000+03.	.1900000+03.
	.0000000+00.	.0000000+00.	.0000000+00.	.0000000+00.
NTC	1			
TCT	1			
	.9000000+02.	.1150000+03.	.1200000+03.	.1250000+03.
	.0000000+00.	.0000000+00.	.0000000+00.	.0000000+00.
NTE	1			
TET	1			
	.4500000+02.	.5000000+02.	.0000000+00.	.0000000+00.
	.0000000+00.	.0000000+00.	.0000000+00.	.0000000+00.
KCR	2			
UAER	1			
	.1160000+03.			

Figure B-1. Example of Input Data--Solar System Program TRANST



AIR RESEARCH MANUFACTURING COMPANY
OF CALIFORNIA

REPRODUCIBILITY OF THE
ORIGINAL PAGE IS POOR

74-10996(8)
Page B-3



AIRESEARCH MANUFACTURING COMPANY
OF CALIFORNIA

EFFAN	*	.49000000+00			
CPL	*	.21000000+00			
TR	*	.80000000+02	.90000000+00	.95000000+02	.00000000+00
TR	*	.67000000+12	.90000000+00	.75000000+02	.00000000+00
NDTE	*	1			
DTET	*	.10000000+02	.75000000+01	.20000000+02	.12500000+02
		.15000000+02			
NDTB	*	1			
DTBT	*	.75000000+01	.10000000+02	.15000000+02	.00000000+00
		.00000000+00			
NDTC	*	1			
DTCT	*	.10000000+02	.15000000+02	.00000000+00	.00000000+00
		.00000000+00			
NTBIN	*	1			
TRINT	*	.20000000+03	.00000000+00	.00000000+00	.00000000+00
		.00000000+00			
NTCIN	*	2			
TCINT	*	.80000000+02	.65000000+02	.00000000+00	.00000000+00
		.00000000+00			
SEND					
STRANS					
TIMET	*	.00000000+00	.10000000+01	.20000000+01	.30000000+01
		.40000000+01	.50000000+01	.60000000+01	.70000000+01
		.80000000+01	.90000000+01	.10000000+02	.11000000+02
		.12000000+02	.13000000+02	.14000000+02	.15000000+02
		.16000000+02	.17000000+02	.18000000+02	.19000000+02
		.20000000+02	.21000000+02	.22000000+02	.23000000+02
		.24000000+02			
GCCLT	*	.00000000+00	.00000000+00	.00000000+00	.00000000+00
		.00000000+00	.00000000+00	.00000000+00	.00000000+00
		.00000000+00	.00000000+00	.13416700+06	.13416700+06
		.13416700+06	.13416700+06	.13416700+06	.13416700+06
		.00000000+00	.00000000+00	.00000000+00	.00000000+00
		.00000000+00	.00000000+00	.00000000+00	.00000000+00
		.00000000+00			
GIT	*	.78000000+04	.77000000+04	.75000000+04	.71000000+04
		.70000000+04	.68000000+04	.63000000+04	.61000000+04
		.60000000+04	.75000000+04	.12400000+05	.19000000+05
		.23600000+05	.24700000+05	.23200000+05	.21000000+05
		.18700000+05	.16300000+05	.13300000+05	.10800000+05
		.90000000+04	.80000000+04	.77000000+04	.74000000+04
		.73000000+04			
HTA	*	.73000000+02	.72000000+02	.71000000+02	.71000000+02
		.70500000+02	.70000000+02	.70000000+02	.71000000+02
		.73000000+02	.73000000+02	.73000000+02	.73000000+02
		.73000000+02	.73000000+02	.73000000+02	.73000000+02
		.73000000+02	.73000000+02	.73000000+02	.73000000+02
		.80000000+02	.80000000+02	.80000000+02	.80000000+02
		.80000000+02			
TG3T	*	.73000000+02	.72000000+02	.71399999+02	.70799999+02
		.70500000+02	.70199999+02	.70099999+02	.72500000+02
		.77000000+02	.80000000+02	.82000000+02	.83500000+02
		.84799999+02	.86099999+02	.87099999+02	.88000000+02
		.88000000+02	.87000000+02	.86000000+02	.84500000+02
		.82500000+02	.81099999+02	.80299999+02	.80000000+02
		.80000000+02			
TW1	*	.61000000+02			
DTS	*	.49999999+01			
SEND					

Figure B-1 (Continued)

 A RESEARCH MANUFACTURING COMPANY
OF CALIFORNIA

TIME HR	TANK T DEG F	PAR PKR P/TTTS	AUX PKR P/TTTS	TOT PKR P/TTTS	CUM P P KWH	CUM A P KWH	CUM PKR KWH	TH COP	EER BTU/H	CAPACITY BTU/H	LOAD BTU/H	CUM COLL BTU	CUM LOSSES BTU
11.05	184.02	1350.00	.00	1350.00	4.19	.00	4.19	.59	20.92	28242.	19000.	204604.	74983.
11.10	184.15	1350.00	.00	1350.00	4.24	.00	4.24	.59	20.94	28274.	19230.	211312.	75460.
11.15	184.28	1350.00	.00	1350.00	4.29	.00	4.29	.59	20.97	28306.	19460.	218021.	75938.
11.20	184.40	1350.00	.00	1350.00	4.33	.00	4.33	.59	20.99	28339.	19690.	224729.	76417.
11.25	184.53	1350.00	.00	1350.00	4.38	.00	4.38	.59	21.02	28370.	19920.	231437.	76895.
11.30	184.65	1350.00	.00	1350.00	4.43	.00	4.43	.59	21.04	28402.	20150.	238146.	77374.
11.35	184.79	1350.00	.00	1350.00	4.48	.00	4.48	.59	21.06	28434.	20380.	244854.	77853.
11.40	184.91	1350.00	.00	1350.00	4.53	.00	4.53	.59	21.09	28465.	20610.	251562.	78333.
11.45	185.04	1350.00	.00	1350.00	4.57	.00	4.57	.59	21.11	28496.	20840.	258271.	78813.
11.50	185.16	1350.00	.00	1350.00	4.62	.00	4.62	.59	21.13	28527.	21070.	264979.	79293.
11.55	185.29	1350.00	.00	1350.00	4.67	.00	4.67	.59	21.15	28557.	21300.	271687.	79773.
11.59	185.41	1350.00	.00	1350.00	4.73	.00	4.73	.59	21.18	28588.	21530.	278396.	80254.
11.65	185.54	1350.00	.00	1350.00	4.78	.00	4.78	.59	21.20	28618.	21760.	285104.	80735.
11.70	185.66	1350.00	.00	1350.00	4.83	.00	4.83	.59	21.22	28648.	21990.	291812.	81216.
11.75	185.78	1350.00	.00	1350.00	4.88	.00	4.88	.59	21.24	28678.	22220.	298521.	81697.
11.80	185.90	1350.00	.00	1350.00	4.93	.00	4.93	.59	21.27	28708.	22450.	305229.	82179.
11.85	186.02	1350.00	.00	1350.00	4.99	.00	4.99	.59	21.29	28738.	22680.	311937.	82661.
11.90	186.14	1350.00	.00	1350.00	5.04	.00	5.04	.59	21.31	28767.	22910.	318646.	83143.
11.95	186.26	1350.00	.00	1350.00	5.10	.00	5.10	.59	21.33	28797.	23140.	325354.	83626.
12.00	186.38	1350.00	.00	1350.00	5.15	.00	5.15	.58	21.35	28826.	23370.	332062.	84109.
12.05	186.50	1350.00	.00	1350.00	5.20	.00	5.20	.58	21.37	28855.	23600.	338771.	84592.
12.10	186.62	1350.00	.00	1350.00	5.26	.00	5.26	.58	21.40	28884.	23655.	345479.	85075.
12.15	186.74	1350.00	.00	1350.00	5.32	.00	5.32	.58	21.42	28913.	23710.	352188.	85558.
12.20	186.86	1350.00	.00	1350.00	5.37	.00	5.37	.58	21.44	28941.	23765.	358896.	86042.
12.25	186.97	1350.00	.00	1350.00	5.43	.00	5.43	.58	21.46	28970.	23820.	365604.	86526.
12.30	187.09	1350.00	.00	1350.00	5.48	.00	5.48	.58	21.48	28999.	23875.	372313.	87011.
12.35	187.21	1350.00	.00	1350.00	5.54	.00	5.54	.58	21.50	29027.	23930.	379021.	87495.
12.40	187.33	1350.00	.00	1350.00	5.59	.00	5.59	.58	21.52	29056.	23985.	385729.	87980.
12.45	187.44	1350.00	.00	1350.00	5.65	.00	5.65	.58	21.54	29085.	24040.	392438.	88465.
12.50	187.56	1350.00	.00	1350.00	5.71	.00	5.71	.58	21.57	29114.	24095.	399146.	88950.
12.55	187.68	1350.00	.00	1350.00	5.76	.00	5.76	.58	21.59	29142.	24150.	405854.	89436.
12.60	187.80	1350.00	.00	1350.00	5.82	.00	5.82	.58	21.61	29170.	24205.	412563.	89922.
12.65	187.91	1350.00	.00	1350.00	5.87	.00	5.87	.58	21.63	29198.	24260.	419271.	90408.
12.70	188.03	1350.00	.00	1350.00	5.93	.00	5.93	.58	21.65	29226.	24315.	425979.	90894.
12.75	188.14	1350.00	.00	1350.00	5.99	.00	5.99	.58	21.67	29254.	24370.	432688.	91381.
12.80	188.26	1350.00	.00	1350.00	6.04	.00	6.04	.58	21.69	29281.	24425.	439396.	91867.
12.85	188.37	1350.00	.00	1350.00	6.10	.00	6.10	.58	21.71	29306.	24480.	446104.	92354.
12.90	188.49	1350.00	.00	1350.00	6.15	.00	6.15	.58	21.73	29331.	24535.	452813.	92842.
12.95	188.61	1350.00	.00	1350.00	6.21	.00	6.21	.58	21.75	29357.	24590.	459521.	93329.
13.00	188.72	1350.00	.00	1350.00	6.27	.00	6.27	.58	21.76	29382.	24645.	466229.	93817.
13.05	188.84	1350.00	.00	1350.00	6.32	.00	6.32	.58	21.78	29407.	24700.	472938.	94305.
13.10	188.95	1350.00	.00	1350.00	6.38	.00	6.38	.58	21.80	29432.	24625.	479646.	94793.
13.15	189.07	1350.00	.00	1350.00	6.44	.00	6.44	.58	21.82	29457.	24550.	486354.	95282.
13.20	189.19	1350.00	.00	1350.00	6.49	.00	6.49	.58	21.84	29481.	24475.	493063.	95771.
13.25	189.30	1350.00	.00	1350.00	6.55	.00	6.55	.58	21.86	29506.	24400.	499771.	96260.
13.30	189.42	1350.00	.00	1350.00	6.60	.00	6.60	.58	21.88	29531.	24325.	506480.	96749.
13.35	189.53	1350.00	.00	1350.00	6.66	.00	6.66	.58	21.89	29556.	24250.	513188.	97239.
13.40	189.65	1350.00	.00	1350.00	6.72	.00	6.72	.58	21.91	29581.	24175.	519896.	97729.
13.45	189.77	1350.00	.00	1350.00	6.77	.00	6.77	.58	21.93	29606.	24100.	526605.	98220.
13.50	189.88	1350.00	.00	1350.00	6.82	.00	6.82	.58	21.95	29632.	24025.	533313.	98711.
13.55	190.00	1350.00	.00	1350.00	6.88	.00	6.88	.58	21.97	29657.	23950.	540021.	99202.
13.60	190.12	1350.00	.00	1350.00	6.93	.00	6.93	.58	21.99	29682.	23875.	546730.	99693.
13.65	190.23	1350.00	.00	1350.00	6.99	.00	6.99	.58	22.01	29707.	23800.	553438.	100185.
13.70	190.35	1350.00	.00	1350.00	7.04	.00	7.04	.58	22.02	29732.	23725.	560146.	100677.
13.75	190.47	1350.00	.00	1350.00	7.10	.00	7.10	.58	22.04	29757.	23650.	566855.	101169.

Figure B-2. Example of Output Data--Solar System Program TRANST

APPENDIX C

PRELIMINARY SPECIFICATION

This appendix contains a preliminary specification for a Rankine cycle solar-powered air conditioner featuring a turbocompressor with an integral motor. The specification was developed for a 10.5-kw (3-ton) capacity unit. Data presented include the following:

(a) System characteristics

- Functional description
- System interfaces
- System performance
- System package

(b) Characteristics of major components

- Evaporator
- Condenser
- Boiler
- Turbocompressor with integral electric motor

FUNCTIONAL DESCRIPTION

Rankine Cycle Air Conditioner Process

A simplified schematic of the Rankine cycle solar-powered air conditioner is presented in Figure C-1. The thermodynamic processes occurring in the system are illustrated in the accompanying p-h diagram. The system utilizes low-grade thermal energy from a flat plate solar collector to generate mechanical power, which in turn drives the compressor of a mechanical refrigeration system. The power loop expander is a single-stage high-speed turbine directly coupled to a centrifugal compressor. To obviate sealing problems, a common working fluid, R-11, is used in the power and refrigeration loops.

In the Rankine power loop, the working fluid is boiled at high pressure using stored thermal energy as the heat source. The vapor produced is expanded in a turbine and condensed at low pressure in an evaporative-type condenser. The liquid is then pumped back to the boiler. A portion of the condensate is throttled in an expansion valve and evaporated at low pressure in a heat exchanger, thus providing cooling to the conditioned airstream. The vapor is then compressed and returned to the common condenser.



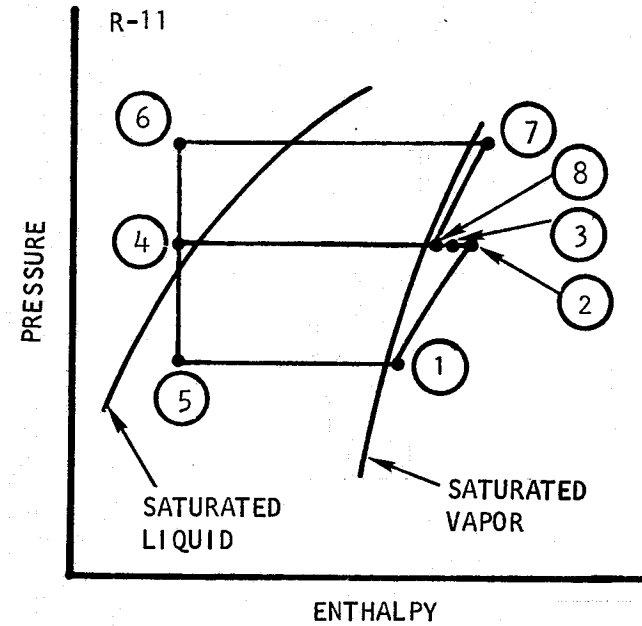
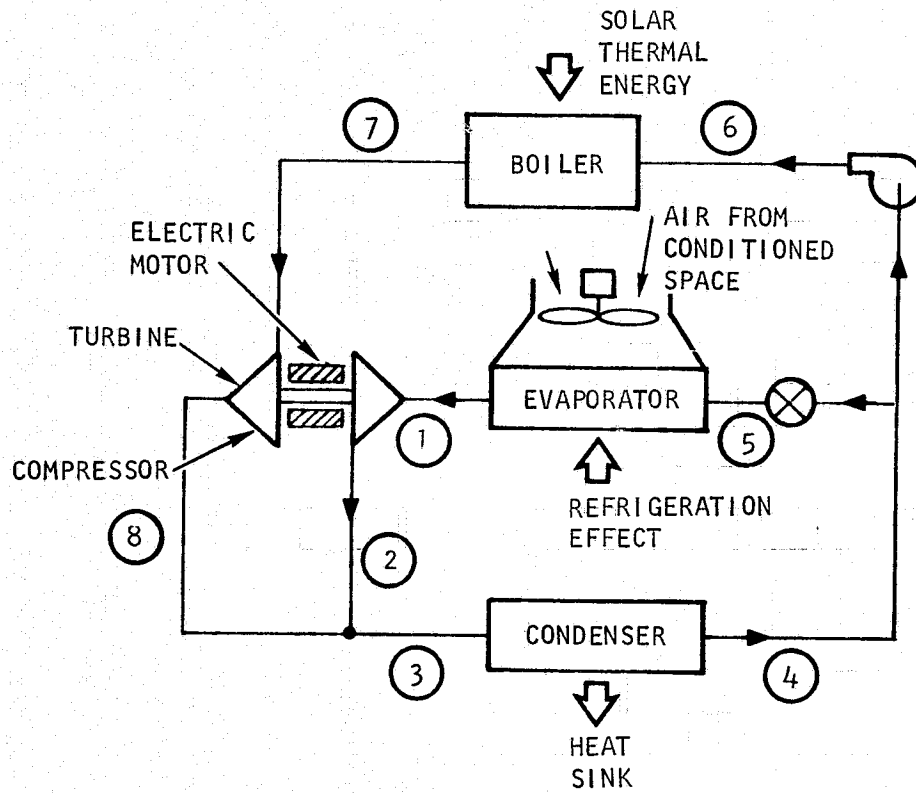

S-196

Figure C-1. Rankine-Cycle Air Conditioner Process

When the thermal energy available from the solar collector/thermal energy storage is insufficient to satisfy the demand for air conditioning, a high-frequency motor mounted directly on the turbocompressor shaft is activated and supplements the power developed by the turbine.

System Operation

Figure C-2 is a schematic of the complete system showing the arrangement of the various system components including the controls.

The condenser is an evaporative type unit. Water is sprayed on the tubes of the condenser, where it evaporates using the thermal energy released by condensation of the working fluid. Evaporation of the water occurs at low temperature, near the wet bulb temperature of the ambient airstream circulated through the unit. Water collected in a pan at the bottom of the condenser package is recirculated by means of a pump. A demistor above the water nozzles prevents liquid water carryover.

The boiler is also a tubular unit; the shell is filled with R-11 and covers the tube bundle through which hot water from the thermal energy storage unit is circulated. Pool boiling occurs on the outside surface of the tubes; a demistor above the tube bundle prevents liquid droplet entrainment. A superheat section downstream of the demistor provides adequate superheat in the vapor to assure against condensation from the bulk of the vapor stream as it expands through the turbine nozzle.

The control system is designed for on-off operation in the normal mode of operation, when the solar thermal energy is adequate to drive the refrigeration compressor; and also in the augmented mode when the electric motor supplements the turbine.

Control in the normal mode of operation is as follows. A thermostat and on-off switch are provided at a suitable location in the residence. When the air conditioner is switched on, the control module assumes control for automatic cycling of the system from the thermostat upper and lower set point temperatures. In addition, the ON switch activates the evaporative condenser water pump and opens the condenser sump solenoid bleed valve.

When the residence temperature exceeds the upper thermostat set point, the evaporator and condenser fan and the R-11 boiler feed pump are activated. At the same time, the boiler isolation and evaporator shutoff valves are opened. As the system operates, the residence temperature will drop until the thermostat lower set point is reached. Then the control module will deactivate the fans, refrigerant pump, and solenoid valves, and the system will assume a standby status.

With the evaporator shutoff valve opened, the flow of refrigerant to the evaporator is controlled by a capillary tube.



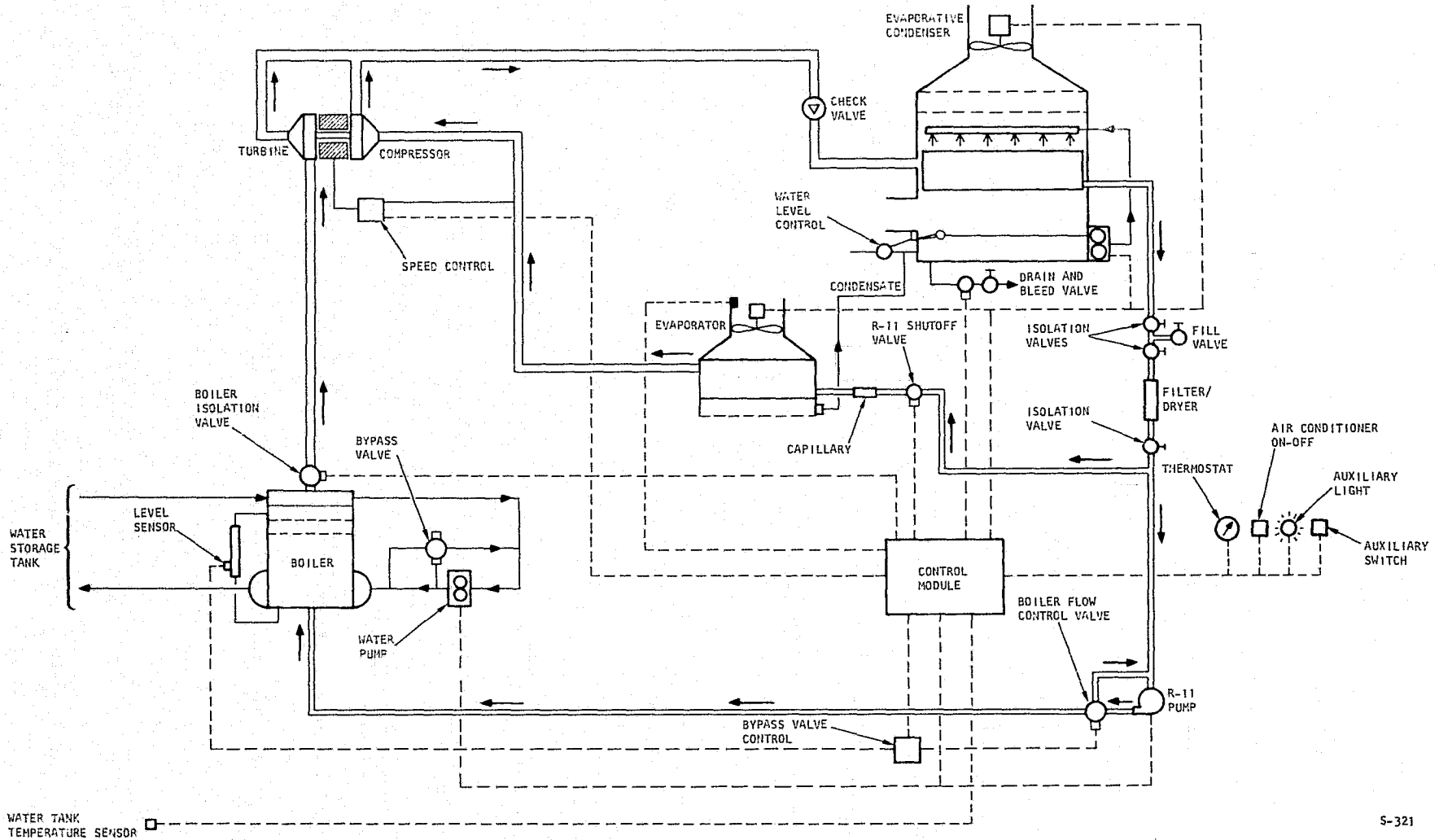

Figure C-2. System Schematic

The water level in the sump of the evaporative condenser is controlled between fixed limits by means of a float-actuated water shutoff valve. A fixed bleed is provided to prevent salt accumulation; the rate of bleed can be adjusted manually depending on the local water salt content. Water recirculation will be maintained during standby conditions to prevent periodic drying of the water on the surface of the evaporator tubes and to obviate salt deposition and corrosion. In addition, the water flow in the condenser tubes will prevent heating of the condenser during standby and keep the condenser near its operating temperature. This will provide a significant advantage toward the elimination of startup transients. A check valve in the vapor line to the condenser, together with the refrigerant shutoff valve at the evaporator inlet, will prevent refrigerant transfer to the evaporator during standby and shutdown. Subcooled conditions will be preserved in the condenser lower tubes, and a positive head will be available for refrigerant pump startup.

A level sensor is provided on the boiler to control a pump bypass valve and thus adjust the refrigerant flow to match the boiling rate. An isolation valve in the vapor line to the turbine is opened during operation. This valve is closed when the system is on standby to prevent refrigerant migration to the evaporator or condenser. This prevents flooding of these two heat exchangers and also maintains the boiler at pressure and temperature. A continuous reduced flow of hot water through the boiler is provided to offset the effects of heat losses and valve leakage during standby. In this manner, the boiler is maintained at high pressure, and startup transients are minimized.

Turbocompressor speed is controlled below a maximum value consistent with the aerodynamic and structural characteristics of the turbine and the compressor by monitoring the temperature of the hot water to the boiler. A bypass valve limits heat input to the system below a safe value compatible with maximum turbomachine speed. Water bypass will start at a temperature of 372.2 K (210 F) and increase with water temperature.

A warning light is installed near the thermostat to indicate when auxiliary power is used. A switch is provided for overriding the automatic mode of operation in the ON or OFF positions. Such a control is desirable for maximum economy or for system capacity enhancement to meet maximum demand situations that could occur during initial residence cooldown or in extreme climatic conditions.

If the water temperature in the solar energy storage tank drops to a value where turbine power is insufficient to drive the refrigeration compressor, the control module will activate the electric motor integral with the turbocompressor. The turbocompressor will then operate at a constant speed of 63,000 rpm. The signals used for motor activation are (1) the turbomachine speed and flow at compressor inlet to prevent compressor surge under all operating conditions, and (2) the water storage tank temperature: when this temperature drops below 336.1 K (145 F), the boiler is deactivated.



To obviate situations where continuous operation in the augmented mode does not generate sufficient capacity to reduce the residence temperature below the lower thermostat set point, a storage water tank temperature sensor is included. The signal from this sensor allows activation of the auxiliary motor only when the water temperature is below 366.4 K (200 F). This signal also is used to switch off the auxiliary motor when tank water temperature increases. The auxiliary power and the entire system are switched off when the residence temperature reaches the lower thermostat set point; the air conditioner control is then reset for baseline operation without the auxiliary motor.

SYSTEM INTERFACES

The system interfaces with the following:

- (a) Solar thermal energy storage unit--Water from the hot water tank is circulated through the boiler and returned to the tank. Water flow rate is 0.0009 m³/sec (13.8 gpm). A tank water temperature sensor provides the signal to deactivate the auxiliary motor control circuitry with the water supply temperature exceeds 366.5 K (200 F).
- (b) Municipal water supply--City water is plumbed to the condenser to provide the evaporant necessary for operation. Water consumption at the rated capacity of the unit is estimated at 19 cm³/sec (2.4 ft³/hr).
- (c) Residence air distribution ducting--The evaporator is connected to the conditioned space air return and fuel ducts.
- (d) Electrical power--Normal house power (60 Hz, 220 v, 3 wire) is supplied to the control module to power the fans, pumps, controls, and auxiliary motor. In the normal mode of operation, total power draw is 1.35 kw. In the augmented mode when the auxiliary motor assumes the entire load, total power input to the air conditioner is estimated at 2.5 kw under standard operating conditions.
- (e) Water drain--Water bleed from the evaporative condenser is drained to the residence sewer line. The rate of water bleed established will depend on local water quality.

SYSTEM PERFORMANCE

The performance of the 10.5-kw (3-ton) air conditioner is listed in Table C-1 corresponding to standard ARI rating conditions. The data are presented for a hot water supply temperature to the boiler of 366.4 K (200 F).

Performance at off-design conditions corresponding to hot water supply temperatures other than 366.4 K (200 F) are given in Figures C-3 through C-6 for a range of ambient and residence wet bulb temperatures.



TABLE C-1
SYSTEM DESIGN POINT PERFORMANCE

Design Conditions

Capacity: 10.55 kw (3 tons) nominal

Hot water supply temperature: 366.5 K (200 F)

Ambient temperatures: 308.2 K (95 F) db, 297 K (75 F) wb

Conditioned air return temperatures: 299.8 K (80 F) db, 292.6 K (67 F) wb

Overall System Parameters

COP: 0.626

Electrical power requirements: 1.35 kw (normal); 2.5 kw (augmented mode)

Water usage: 19 cm³/sec (2.4 ft³/hr)

Cycle Data

Boiling temperature: 357.5 K (183.5 F)

Condensing temperature: 306 K (90.8 F)

Evaporating temperature: 280.4 K (45 F)

Power loop efficiency: 0.099

Refrigeration loop COP: 7.03

Overall COP: 0.626



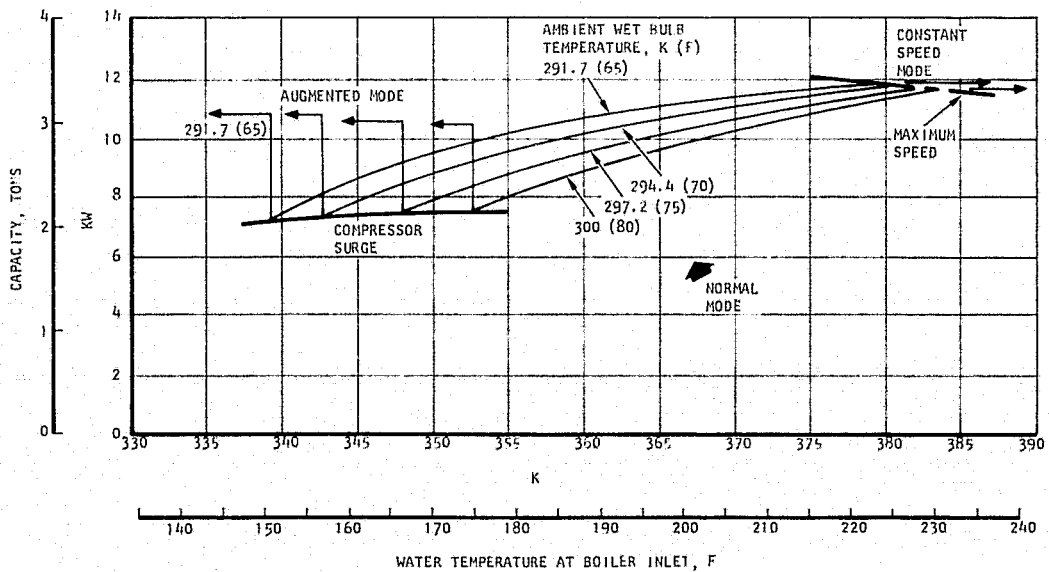
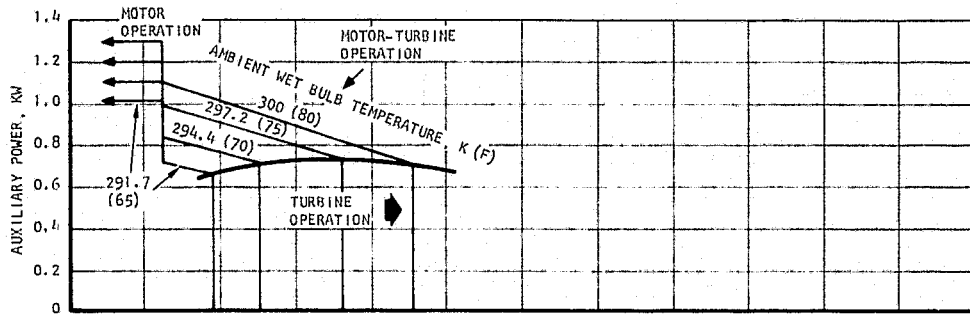
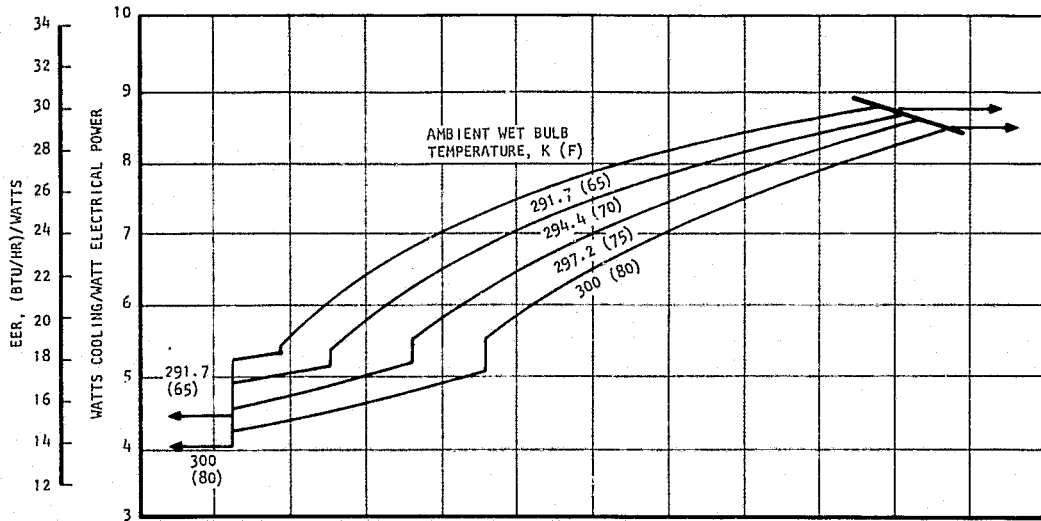

5-151

Figure C-3. Auxiliary Motor System Performance--Residence Wet Bulb Temperature = 392.8 K (67 F)



AIRESEARCH MANUFACTURING COMPANY
OF CALIFORNIA

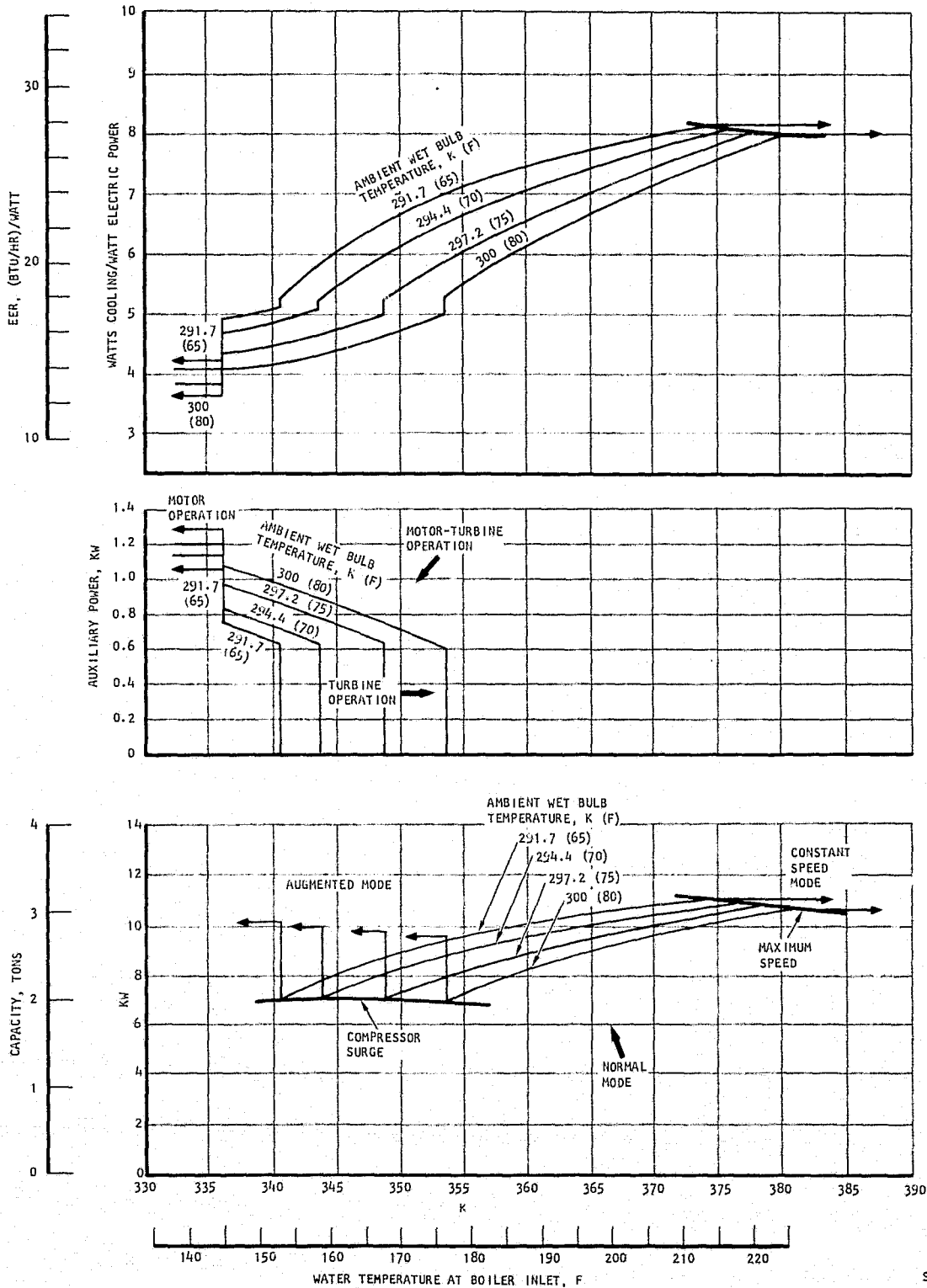

S-192

Figure C-4. Auxiliary Motor System Performance--Residence Wet Bulb Temperature = 291.1 K (64 F)



AIRESEARCH MANUFACTURING COMPANY
OF CALIFORNIA

REPRODUCIBILITY OF THE
ORIGINAL PAGE IS GOOD

74-10996(8)
Page C-9

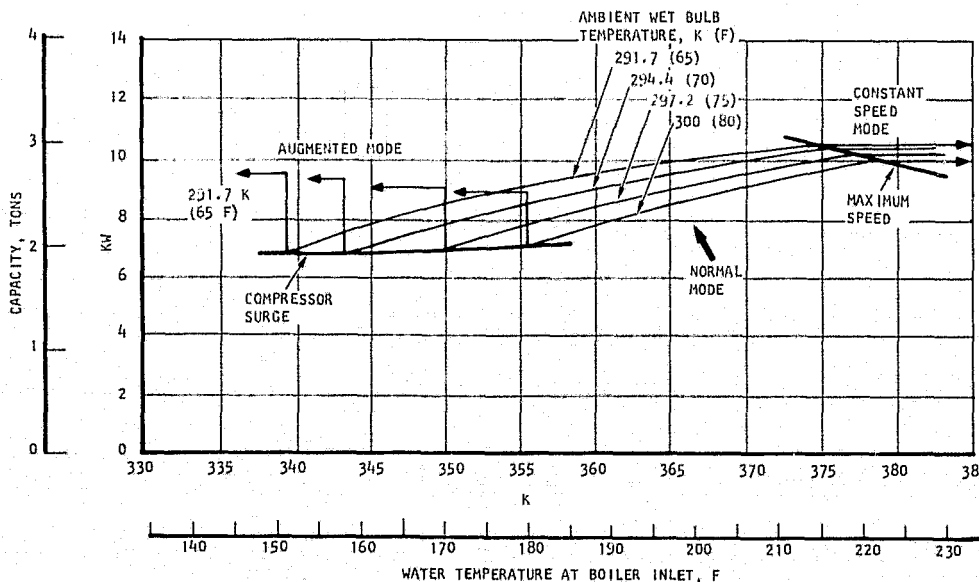
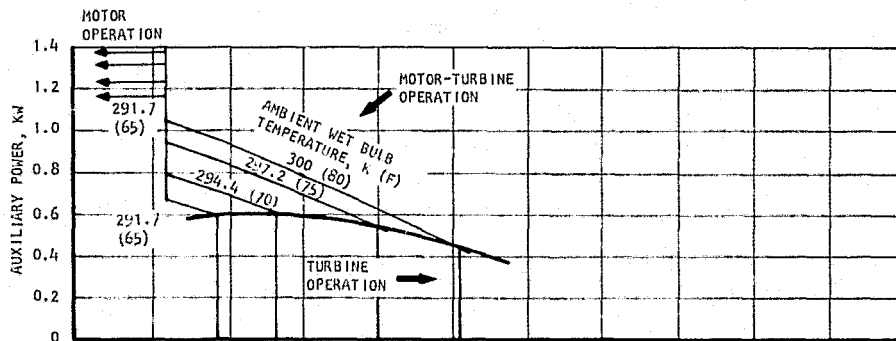
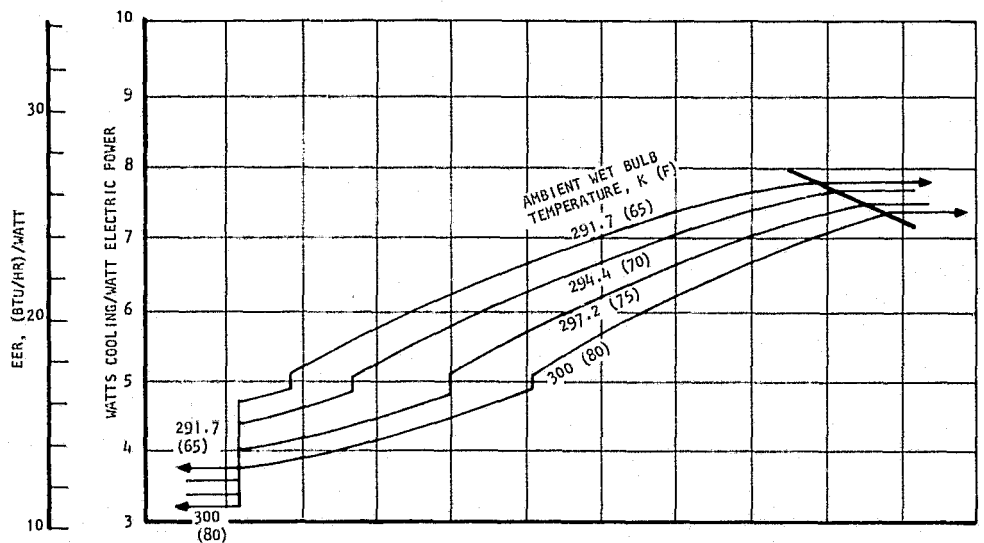

Figure C-5. Auxiliary Motor System Performance--Residence Wet Bulb Temperature = 289.4 K (61 F)



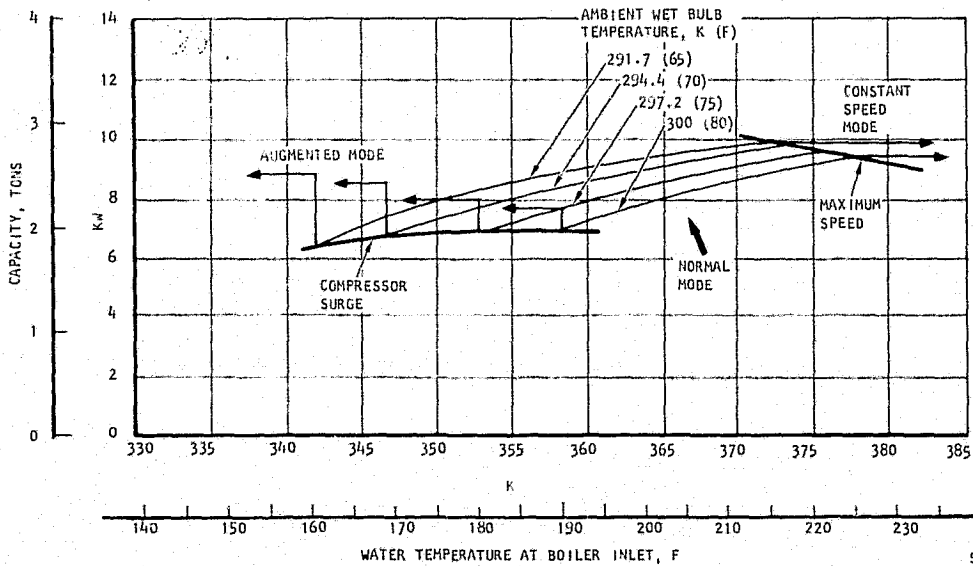
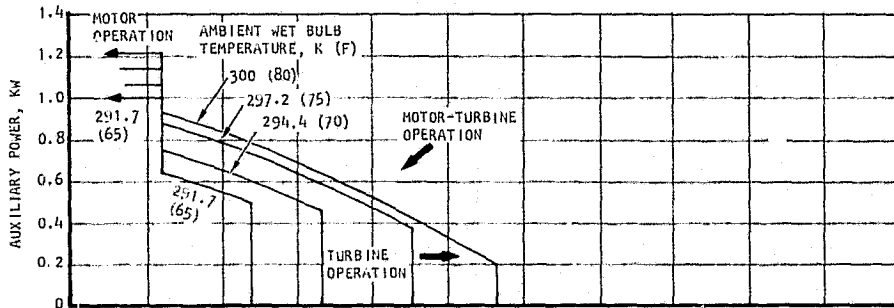
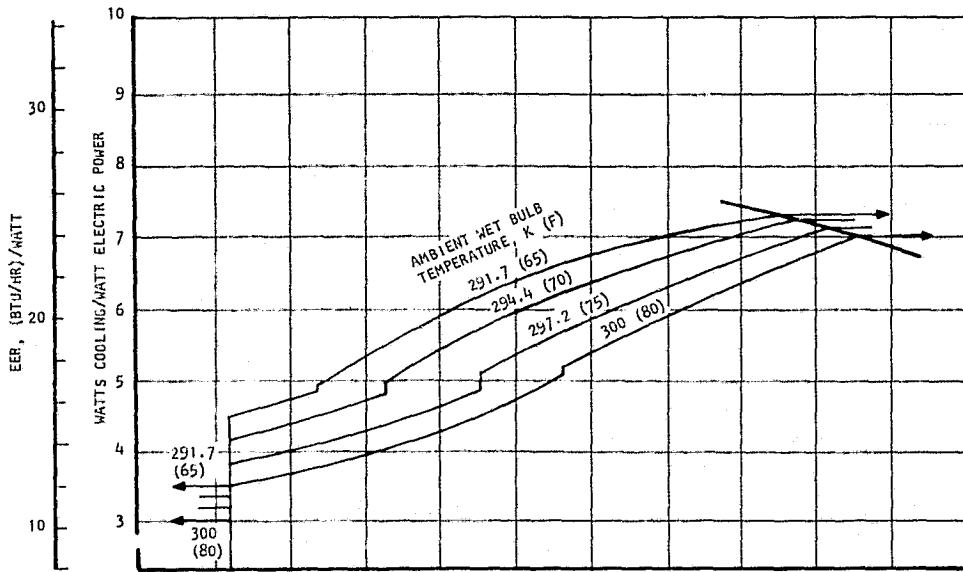

Figure C-6. Auxiliary Motor System Performance--Residence Temperature = 287.8 K (58 F)



SYSTEM PACKAGE

The position of the major components on the schematic of Figure C-2 attempts to illustrate the relative location of the major components in the system package. The turbocompressor is positioned high in the package to (1) minimize the possibility of liquid refrigerant draining into the compressor and turbine from the condenser lines, (2) minimize entrained liquid refrigerant entering the compressor from the evaporator during startup, and (3) provide adequate line length to ensure vaporization of all liquid refrigerant droplets passing through the superheater section of the boiler. The line from the boiler to the turbine provides for liquid gravity drain back into the boiler. The hot water line from the solar collector is routed adjacent to the R-11 vapor line to the boiler to obviate condensation on the vapor line wall and maintain superheated conditions at turbine inlet.

The condenser also is located high in the package to provide a maximum hydrostatic head at the evaporator thermal expansion valve and at the inlet to the refrigerant pump. This is particularly important in a system of this type for which the condenser provides only limited subcooling. The refrigerant pump is installed at the lowest level in the package.

All lines are lagged with insulation to minimize heat losses and obviate undesirable performance shifts during startup. For the same reasons, careful attention is required to reduce conduction paths from hot components to cold components and also reduce convection and radiation losses to ambient.

The largest component of the air conditioner is the evaporative condenser. The dimensions of this unit are estimated at 1.5 m (60 in.) high, by 0.6 m (24 in.) wide, by 0.96 m (38 in.) deep. The weight of this unit is estimated at 400 lb. The evaporative condenser should be located outside. Depending on the installation, it may be desirable to separate the condenser from the remainder of the package to provide flexibility.

The remainder of the equipment, excluding the evaporative condenser, can be packaged within a cabinet 1.1 m (42 in.) high, 0.6 m (24 in.) wide, and 0.8 m (32 in.) deep, including the conditioned air recirculation fan. The weight of this second package is estimated at 350 lb.

COMPONENT CHARACTERISTICS

Listed on the following pages are the characteristics of the major components of the system including the evaporator, evaporative condenser, boiler, and turbomachine with integral motor.

Evaporator

The evaporator is a tubular heat exchanger with wavy aluminum fins mechanically bonded to the tubes to maximize the heat transfer area on the air side. The tubes are copper and contain the evaporating R-11. The characteristics of the evaporator are listed in Table C-2 corresponding to design point conditions.



TABLE C-2

EVAPORATOR CHARACTERISTICS

<p><u>Heat Transfer Surface</u></p> <ul style="list-style-type: none"> ● 0.95-cm (3/8-in.) dia. copper tubes with wavy aluminum fins ● Tube pattern: 2.54 cm (1 in.) on center, staggered in the airflow direction ● Number of fins: 3.9/cm (10/in.) ● Fin thickness: 0.15 mm (0.006 in.)
<p><u>Core Dimensions</u></p> <ul style="list-style-type: none"> ● Face area: 0.158 m² (245 in.²) ● Depth: 17.6 cm (6.93 in.) ● Number of tube rows: 8
<p><u>Performance</u></p> <ul style="list-style-type: none"> ● Heat rejection rate: 10.5 kw (36,000 Btu/hr), nominal ● Hot side (air) <ul style="list-style-type: none"> Flow: 0.4 m³/sec (850 cfm) Air inlet dry bulb temperature: 300 K (80 F) Air inlet wet bulb temperature: 293 K (67 F) Air outlet dry bulb temperature: 286 K (55 F) Air outlet wet bulb temperature: 285 K (53.4 F) Air pressure drop: 124 N/m² (0.5 in. H₂O) ● Cold side (R-11) <ul style="list-style-type: none"> Flow: 64 g/sec (504 lb/hr) Evaporating temperature: 281 K (45.6 F) Superheat: 2.8 K (5 F) Evaporating pressure: 58.7 kN/m² (8.5 psia) Pressure drop: 2.8 kN/m² (0.4 psi)



Evaporative Condenser

This unit incorporates a tubular heat exchanger, an air circulation fan, a water pump, and water spray nozzles. Water is sprayed downward uniformly on top of the tube bundle; ambient air is circulated in a direction opposite to that of the water flow and exhausted on top of the unit. The water evaporates on the surface of the tubes using the heat of condensation of the refrigerant. Water vapor is entrained by the airstream, which exits the unit nearly saturated with water. A demistor above the water nozzle prevents liquid water entrainment. A water sump collects the excess water from the tube bundle and is recirculated to the spray nozzle by a pump. The water level in the sump is maintained constant by a float valve that controls the water supply to the unit.

The characteristics of the condenser are listed in Table C-3.

Boiler

The boiler consists of a tube bundle through which hot water from the storage tank is circulated. The tube bundle is submerged in the working fluid, and pool boiling occurs outside the tubes. The level of the refrigerant is maintained in the boiler by control of the bypass flow around the refrigerant pump. A level sensor on the boiler provides the signal for bypass valve positioning.

Upstream of the tube bundle, a demistor is used for liquid separation so that only small quantities of liquid R-11 are entrained into the superheater section of the boiler located above the demistor. The hot water is circulated through the superheater section first and then through the pool boiler tube bundle before returning to the thermal energy storage tank.

Table C-4 summarizes the characteristics of the boiler.

Turbocompressor-Motor

The turbocompressor-motor consists of a radial inflow turbine driving a single-stage centrifugal compressor during normal operation. A high-speed high-frequency motor mounted on the same shaft is activated to supplement turbine power when necessary. The motor can provide the power necessary to drive the compressor without the turbine. Design speed is 63,000 rpm.

The rotor is supported on two hydrodynamic foil bearings. No lubricant other than the process fluid is necessary. The input to the motor is from a frequency converter which converts 230-v, 60-Hz, single-phase, 3-wire, normal house power to 120-v, 3150-Hz, 3-phase current.

Table C-5 summarizes the characteristics of the turbocompressor-motor.



TABLE C-3
CONDENSER CHARACTERISTICS

Heat Transfer Surface

- 1.27-cm (0.5-in.) copper tubes with internal extended surface
- Tubes staggered with respect to airflow on 2.54-cm (1.0-in.) center
- Prime surface area: 3.8 m² (41.4 ft²)

Dimensions

- Core: 10.2 cm (26 in.) long, 45.7 cm (18 in.) wide, 20.3 cm (8-in.) deep
- Overall unit: 1.5 m (60 in.) high, 0.6 m (24 in.) wide, 0.96 m (38 in.) deep.

Performance

- Heat rejection rate: 27.0 kw (93,000 Btu/hr)
- Cold side (air and water)
 - Airflow: 1.92 m³/sec (4050 cfm)
 - Air inlet dry bulb temperature: 308.3 K (95 F)
 - Air inlet wet bulb temperature: 297 K (75 F)
 - Air outlet wet bulb temperature: 300 K (80.2 F)
 - Water flow: 0.064 kg/sec (510 lb/hr)
 - Water evaporation rate: 19 g/sec (150 lb/hr)
- Hot side (R-11)
 - Flow: 0.145 kg/sec (1158 lb/hr)
 - Inlet temperature: 320.1 K (117.5 F)
 - Condensing temperature: 306 K (90.7 F)
 - Subcooling: 2.8 K (5 F)
 - Pressure drop: 7 kN/m² (1 psi)
- Power requirements: 920 watts



TABLE C-4

BOILER CHARACTERISTICS

Heat Transfer Surface

- 0.953-cm (3/8-in.) copper tubes staggered in vertical direction
- Tube pitch: 1.91 cm (0.75 in.)
- Prime surface area:
 - (a) Boiling section: 1.37 m² (14.7 ft²)
Total of 150 tubes 30.5 cm (12 in.) long manifolded so that water makes three passes through the tube bundle
 - (b) Superheat section: 0.46 m² (4.9 ft²)
Total 50 tubes 30.5 cm (12 in.) long; water makes one pass through the bundle

Dimensions

- Core
 - (a) Boiling section tube bundle:
30.5 x 33 x 15.7 cm (12 x 13 x 6.2 in.)
 - (b) Superheat section tube bundle:
30.5 x 33 x 4.3 cm (12 x 13 x 1.7 in.)
- Overall unit: 40.6 cm (16 in.) long x 33 cm (13 in.) wide x 40.6 cm (16 in.) high

Performance

- Boiler section
 - (a) Heat rejection rate: 16.75 kw (57,170 Btu/hr)
 - (b) Cold side (R-11)
 - Flow rate: 0.083 kg/sec (654 lb/hr)
 - Inlet temperature: 306.6 K (91.9 F)
 - Boiling temperature: 357.5 K (183.5 F)
 - Inlet pressure: 610.2 kN/m² (88.5 psia)
 - Pressure drop: 22.8 kN/m² (3.3 psi)
 - (c) Hot side (water)
 - Flow rate: 0.87 kg/sec (6927 lb/hr)
 - Inlet temperature: 366.6 K (199.9 F)
 - Inlet pressure: TBD
 - Pressure drop: 34.5 kN/m² (5 psi) max



TABLE C-4 (Continued)

Performance (Continued)

● Superheat section

(a) Heat rejection rate: 0.27 kw (916 Btu/hr)

(b) Cold side (R-11)

Flow rate: 0.083 kg/sec (654 lb/hr)

Inlet temperature: 357.5 K (183.5 F)

Inlet pressure: 587.4 kN/m² (85.2 psia)

Pressure drop: 7.0 kN/m² (1.0 psi)

(c) Hot side (water):

Flow rate: 0.87 kg/sec (6927 lb/hr)

Inlet temperature: 366.7 K (200 F)

Inlet pressure: TBD

Pressure drop: 10.3 kN/m² (1.5 psi) max



TABLE C-5

TURBOCOMPRESSOR-MOTOR CHARACTERISTICS

<u>Turbine</u>	
Flow:	0.083 kg/sec (654 lb/hr)
Inlet pressure:	580.5 kN/m ² (84.2 psia)
Inlet temperature:	363.1 K (193.5 F)
Inlet enthalpy:	269.5 J/g (116.1 Btu/lb)
Outlet pressure:	146.2 kN/m ² (21.2 psia)
Outlet temperature:	317.4 K (111.4 F)
Outlet enthalpy:	249.3 J/g (107.4 Btu/lb)
Rotational speed:	61,320 rpm
Diameter:	4.49 cm (1.77 in.)
Efficiency:	0.80
<u>Compressor</u>	
Flow:	0.062 kg/sec (504 lb/hr)
Inlet pressure:	55.8 kN/m ² (8.1 psia)
Inlet temperature:	283.7 K (50.6 F)
Inlet enthalpy:	229.3 J/g (98.8 Btu/lb)
Outlet pressure:	146.2 kN/m ² (21.2 psia)
Outlet temperature:	328.6 K (131.4 F)
Outlet enthalpy:	253.5 J/g (109.2 Btu/lb)
Rotational speed:	61,320 rpm
Diameter:	6.17 cm (2.43 in.)
Efficiency:	0.68
<u>Motor</u>	
Input power:	120 v, 3 ϕ , 3150 Hz
Design speed:	63,000 rpm
Maximum output power:	2 kw

