

N76-31148

THE C-5A ACTIVE LIFT DISTRIBUTION CONTROL SYSTEM

William J. Hargrove
Lockheed-Georgia Company

SUMMARY

An Active Lift Distribution Control System (ALDCS) has been developed for the C-5A as a means to reduce wing fatigue damage due to maneuver and gust load sources. The Lockheed-Georgia Company proposed a four phase program; the development and design of a prototype system, flight test evaluation, production system fabrication, and airplane fleet installation of this subsystem.

This paper describes the ALDCS development and design tasks, ALDCS functional configuration, and resulting challenges encountered while accomplishing the first phase of the program. These tasks are establishing system requirements and criteria and synthesizing a system mechanization to meet the desired load alleviation, stability margins, flight safety, and flying qualities performance. Results of the ALDCS development and prototype system flight simulation programs, and control law optimization including system stability, handling qualities and structural load analyses are presented, along with concluding remarks relative to the system design integration.

INTRODUCTION

An Active Lift Distribution Control System (ALDCS) has been developed by Lockheed-Georgia Company under the direction of the USAF C-5 System Project Office to reduce wing fatigue damage due to incremental maneuver and gust load sources.

The ALDCS is an automatic flight control subsystem which provides redistribution of the wing spanwise lift through symmetrical deflection of the ailerons by inclusion of control inputs to the existing lateral augmentation subsystem. The net aileron control effect, as illustrated in figure 1, is to shift the wing spanwise center of pressure inboard, thus reducing the incremental wing root bending moments. Control input signals from the ALDCS are also provided to the inboard elevator surfaces through the existing pitch augmentation subsystem for reduction of gust induced loads and to compensate for the resulting degradation in airplane handling qualities.

Although the primary objective of the ALDCS is to reduce wing loads, minimizing the effects on the basic aircraft stability and handling qualities and

minimizing changes to existing hardware while utilizing existing control surfaces were also basic design goals.

SYMBOLS AND SUBSCRIPTS

N_Z	Normal acceleration load factor.
$\dot{\theta}$	Pitch rate.
δ_F	Flap position.
M_X	Bending moment.
A/C	Aircraft
\bar{q}	Equivalent dynamic pressure.
g	Acceleration constant (32.2 ft/sec ²)
M	Mach number
Ve	Equivalent Airspeed
CADC	Central Air Data Computer.
C.G.	Center of gravity.
db, DB	Decibel
ECP	Elevator cable position.
H.Q.	Handling qualities.
Hz	Hertz.
K	One thousand.
KCAS	Knots calibrated airspeed.
M_H	Maximum horizontal flight Mach number.
PLDCS	Passive Lift Distribution Control System.
PSF	Pounds per square foot.
PSD	Power spectrum density.
RMS	Root mean square.

SYMBOLS AND SUBSCRIPTS (CONT'D)

V_D	Maximum dive flight airspeed
SL	Sea level.
V_H	Maximum horizontal flight airspeed.
VSS	Vehicle systems simulator.
W.S.	Wing station.

BACKGROUND

In 1969 the Lockheed-Georgia Company conducted a program to establish the feasibility of reducing the maximum C-5 wing upbending loads during accelerated flight maneuvers. This effort consisted of development, fabrication and flight test of a prototype subsystem referred to as the Maneuver LDCS (MLDCS). This subsystem successfully reduced the inner wing bending moments for positive accelerations above 1.5g without degrading airplane handling qualities. A simplified version of this system known as Passive LDCS (PLDCS) that involves manual aileron uprig through the trim system was selected for the C-5 fleet incorporation.

In 1972 a survey conducted by the C-5 Structural Independent Review Team (IRT) of the possible methods to improve the C-5 wing fatigue life characteristics included a recommendation to consider an active control system to improve fatigue life. A decision was made jointly by the USAF C-5 Systems Project Office and Lockheed-Georgia Company to develop and test such a subsystem which was to be called an Active Lift Distribution Control System. This subsystem was to be incorporated in addition to the PLDCS. In May of 1973 the ALDCS program was initiated for the development and test of a prototype subsystem with flight testing to be completed in July of 1974. The results of this program will affect a decision to produce the ALDCS for C-5 fleet retrofit.

DEVELOPMENT METHODS

A flow chart of the tasks required in the ALDCS development are shown in figure 2. Each task required direct involvement of a number of engineering disciplines to insure adequate assimilation of design requirements and data and proper maintenance of development results and the status of the subsystem mechanization. One of the paramount challenges was the integration of the affected design disciplines into a total design team since the functioning of this active subsystem had such interwoven influences on loads, handling qualities, stability, structural dynamics, and existing C-5 flight control systems. Fortunately, the experience of the earlier LDCS program provided an excellent design example.

Requirements and Criteria

Prior to synthesizing the ALDCS, design requirements and criteria were carefully established as a design base in the areas of structural loads, flight control subsystems, stability, and handling qualities. These requirements are:

Structural Loads -

- Continuous turbulence loads analysis shall result in RMS bending moments at the wing root (wing station 120) not exceeding 70% of the free airplane values.
- The continuous turbulence RMS torsion at the wing root shall not exceed the free aircraft values by more than 5%.
- The ALDCS shall not increase discrete gust loads.
- The incremental root bending moments load per g shall not exceed 70% of the free aircraft values during steady maneuvers, within the normal climb, cruise, and descent regime of the aircraft.
- The ALDCS shall produce no aileron input when the aircraft reaches the design positive maneuver load factor of 2.5.
- The system shall not be required to operate in the flaps down configurations.
- The ALDCS shall operate in the required speed/altitude flight envelope as defined in figure 3 for flaps up configurations.

Flight Control Subsystems -

- The ALDCS shall be designed to "fail-safe" concepts.
- The system shall be a dual channel analog design.
- Active operation of ailerons and inboard elevators through existing augmentation and primary control actuators are required.
- ALDCS will interface with existing C-5 sensors to the extent possible and will be compatible with existing C-5 automatic flight control subsystems.
- No ALDCS malfunction will affect normal pitch and lateral augmentation subsystem operations.
- The existing C-5 hydraulic servoactuators for the aileron and inboard elevators will be used without modifications.

- The ALDCS will be required to operate on a "full-time basis" within the desired flight envelope and design criteria boundaries.

Stability -

The incorporation of the ALDCS shall not:

- Induce adverse structural mode coupling.
- Change significantly the existing maneuvering flight handling qualities.
- Induce significant degradation of existing flutter margins.
- Induce adverse coupling with existing flight control systems.
- Induce limit cycle tendencies.

The following ALDCS minimum stability margin and attenuation goals for each primary control surface feedback loop were established to meet the above system stability requirements. These goals were considered to be realistic and attainable throughout the ALDCS flight envelope.

- Ground Test - 6 db gain margin and 45 degree phase margin.
- Flight modes through control mode natural frequencies - 6 db gain margin and 45 degree phase margin.
- Flight modes above control mode natural frequencies - 6 db gain margin and infinite phase margin. There was also a system attenuation goal of 60 db/decade established for these modes.

Handling Qualities -

- There shall be no significant change in the existing C-5 handling qualities.
- The ALDCS shall be disengaged prior to the aircraft stall event.
- Criteria for the C-5 handling qualities will be those characteristics established during previous flight test programs which concluded the C-5A flying qualities to be acceptable in all cases.
- Evaluation pilot comments will be utilized to obtain satisfactory results.

Design Data Acquisition

The task of acquiring necessary design data was simplified by the existence of airplane math model data, flight control subsystem mechanizations,

and flight test response correlation data from the original C-5 design programs. The major void in design information existed in the characteristics of the aileron and elevator hydraulic servoactuators. This void existed due to the C-5 actuators being designed and tested primarily for handling qualities evaluations and automatic stabilization of aircraft low frequency short period and dutch roll modes, whereas the ALDCS would encompass the sensing and active control of higher frequency aeroelastic mode dynamics, potentially up to a factor of 15 above the short period frequency.

These missing actuator characteristics not only included frequency response but hysteresis, surface rates and tolerance bands in unloaded and loaded conditions. They were desired for actuators of various ages up to an expected full life. These data were obtained by tests on the C-5 Vehicle Systems Simulator of new and worn (over one life span) servoactuators, by tests performed by Bertea Corporation (the servoactuator manufacturer), and by frequency response flight tests on the C-5 aircraft.

A definite "design risk" was associated with the attempt to utilize existing C-5 servoactuators without bandwidth or authority limit modifications.

Computer Programs

Various computer programs were prepared and correlated with flight test data to provide analytical techniques for development of the ALDCS mechanization. These programs using hybrid and digital computation were:

- Stability - Eigenvalues and Frequency Response
- Dynamic Time History - Loads and Handling Qualities
- Accelerated Stability - Stick Force per 'g'
- PSD Loads

The following airplane and control system analytical models were used for the above programs.

- Three degrees-of-freedom quasi-elastic longitudinal axis dynamic models.
- Six degrees-of-freedom quasi-elastic longitudinal and lateral-directional axes dynamic models.
- Eighteen mode aeroelastic symmetric axis dynamic models, with first 15 flexible modes and Wagner and Kussner functions and gust penetration effects.
- Two degrees-of-freedom quasi-elastic steady-state maneuver model.
- Eight mode aeroelastic symmetric axis dynamic model with six most significant flexible modes.

- Linear and non-linear flight control system servoactuator models.

Analysis and Synthesis Tasks

The analysis and synthesis tasks involved the development of an ALDCS mechanization to meet the load alleviation requirements and the determination of its effects on stability, handling qualities and existing flight control subsystem performance. Feedback control laws were synthesized to attain these requirements while minimizing system coupling effects with undesirable structural modes and rigid body dynamics.

Development of a realistic mechanization that could potentially be utilized as a guide for production design required indepth studies to establish the system's total flight envelope functional characteristics, sensor tolerance and response specifications, and prototype parameter adjust capabilities. Also involved were the analyses to determine effects of subsystem failures, component tolerance build-up, and servoactuator response characteristics. Other major analytical studies were accomplished to determine the impact of the ALDCS on handling qualities in the following areas:

- Dynamic Stability
- Maneuverability (Attitude Control)
- Accelerated Stability (Stick Force per 'g')
- Roll Control Performance
- Development of an ALDCS Handling Qualities Command Model

The interaction coupling effects of the flexible bending and rigid body response with the flight control system was thoroughly analyzed. This insured proper control law compensation for those flight conditions during which structural modes and handling qualities tend to degrade each other.

Flight Simulation Tasks

Tasks accomplished on the C-5 Developmental Handling Qualities Cockpit Simulator provided pilot evaluations of the ALDCS effect on the C-5 handling characteristics. The inflight tasks performed by the evaluating pilot consisted of the following:

- Symmetric 'g' pull-ups
- Stabilized bank turns and roll-outs
- Landing approach and flare

- Constant 'g' rolling pull-out maneuvers
- Take-off rotations
- Attitude tracking maneuvers during turbulence
- Air traffic control maneuvering (speed, altitude and heading changes)

The C-5 Developmental Handling Qualities Cockpit Simulator is real-time six degrees-of-freedom simulation with an all digital computation and a terminal area terrain model visual system.

Vehicle System Simulator (VSS) Tasks

Simulation afforded the capability to verify the prototype design and system safety aspects in functional operation checkout and flight control subsystem hardware integration. This technique also provided final pilot evaluations utilizing the prototype subsystem. Pilot tasks were similar to those used on the C-5 Developmental Handling Qualities Cockpit Simulation discussed previously.

The VSS incorporates actual C-5 mechanical and hydraulic flight control systems, moving surfaces and interfacing automatic flight control subsystems.

SCHEDULE MILESTONES

The accomplishment of the analysis, synthesis, simulation and design tasks to meet a restrictive schedule was paramount. Flight test evaluations of the prototype ALDCS were to begin within eleven months from contractual go-ahead. Figure 4 illustrates the criticality of the design program schedule. With go-ahead occurring on 7 May 1973, the subsystem design met the 90 percent functional release date of 21 September 1973. The final mechanization was released on the scheduled date of 7 November 1973 and the first prototype subsystem was made available for flight simulation evaluation on 7 January 1974. Inflight system evaluations began on 15 March 1974, approximately ten months after go-ahead.

SYSTEM MECHANIZATION

The ALDCS has been mechanized to meet the demanding requirements placed on it and to interface with existing C-5 sensors, augmentation and servo-actuation subsystems.

Figure 5 provides a simplified interface diagram indicating the integration of the ALDCS computer with the existing C-5 flight control subsystems. The dual channel redundancy design ALDCS computer provides signals to both the lateral augmentation series servo to control the aileron actuators symmetrically and the pitch augmentation series servo to actuate the inboard elevator control surfaces. Aileron actuators also receive commands from the pilots, autopilot, and passive LDCS. The pilots and autopilot command inboard as well as outboard elevators. Figure 6 shows the C-5 airplane locations of the ALDCS sensors and interfacing computers and affected control surfaces. The wing mounted accelerometers are the only additional C-5 sensors required for ALDCS integration.

The ALDCS mechanization consists of an array of sensors, gains, and filters. Figure 7 is a block diagram of the ALDCS simplified mechanization to be used as a roadmap during the ensuing discussion of the individual components and system development changes. The aileron and elevator channels will be discussed separately.

Aileron Channel

The aileron control channel commands the right and left ailerons symmetrically to accomplish the maneuver load relief function. The feedback sensors utilized for the aileron channel are provided by two vertical accelerometer locations per wing, one located on the forward main beam (W.S. 1186) and the other on the rear beam (W.S. 1152) both at an outer wing location. The signals from these accelerometers are averaged and compensated by smoothing filters that attenuate sensor noise and aid in the elimination of higher frequency wing vibration modes beyond the ALDCS control bandwidth.

The Stability and Load Control Gain and Filtering portion of the aileron channel provides the necessary compensation to adequately phase the feedback accelerometer signals for control of the inner wing bending moments and to attain the design goal stability margins.

A pilot's feedforward command, acquired from the existing C-5 elevator cable position (ECP) transducer, is summed with the compensated acceleration control signal to provide abrupt maneuver load control. The feedforward signal is filtered for proper abrupt load alleviation aileron command phase.

These control signals are then gain scheduled by aircraft dynamic pressure from the Central Air Data Computer (CADC) to provide proper stability and load relief schedules and to minimize handling qualities degradations throughout the aircraft speed envelope. Cut-off filters are provided to preclude adverse coupling with higher frequency uncontrolled modes. The ALDCS aileron command signal is controlled by boundary control logic which contains the circuitry to disengage the signal when exceeding flight boundaries where the ALDCS is not required. These operational boundary conditions are when the flaps are lowered, the Stallimiter subsystem is activated, the airplane exceeds maximum

horizontal airspeed/Mach (350 KCAS /M = 0.825), and when the airplane load factor exceeds 1.9 g's. These logic control signals are obtained from existing aircraft subsystems with the exception of load factor. This signal is derived from ALDCS wing and fuselage accelerometers to closely represent aircraft C.G. acceleration. The system is automatically re-engaged as the aircraft re-enters the ALDCS operational envelope. The aileron command signal is then limited and interfaced with the lateral SAS aileron series servoactuators.

Elevator Channel

The elevator channel contains three sensors, two active feedback parameters and one feedforward command. Airplane pitch rate, as provided by the pitch SAS rate gyro, is utilized to augment the airplane short period damping and thereby alleviate the excitation of short period induced gust loads and to restore the handling qualities degraded by the aileron pitching moment effects.

An existing C-5 autopilot subsystem vertical accelerometer mounted in the forward fuselage provides additional gust load control and compensates the airplane pitch response characteristics.

A feedforward signal, pilot's elevator input command, is required to restore the airplane maneuverability and accelerated stability (stick force per 'g') characteristics that are significantly degraded by the load control signals. This signal is scheduled as a function of airplane dynamic pressure and compensated by a command model filter to provide the proper system handling qualities throughout the operational envelope.

These three signals, pitch rate, normal acceleration and pilot elevator command input are summed and again scheduled with dynamic pressure and passed through system cut-off filters for stability and gust load control phasing.

The elevator signal is provided to a boundary control logic network that disengages the signal under the same conditions as the aileron channel. This circuit includes a fade-out filter to minimize acceleration transients resulting from abrupt surface disengagement. The command signal is then limited and interfaced with the pitch augmentation subsystem.

System Changes

The functional development of the ALDCS provided the usual subsystem changes which caused agonizing perturbations in the design of the prototype subsystem hardware. These modifications of the mechanization fall into the following major areas:

- Wing accelerometer location
- Operational flight envelope

- ° Subsystem stability - filter compensation

Wing Accelerometer Location -

Trade studies were accomplished to determine the number and locations of the wing mounted accelerometers. The C-5 wing locations acceptable to sensor installation are essentially limited to the front and rear beams due to fuel tank locations. Original studies of the wing accelerometer location indicated the need for two sensors per wing, one on the mid-wing aft main beam and one in the outer wing to be mounted on the front main beam. These sensors were to provide "high gain" feedback control of the first and second wing flexible bending modes. Additional studies proved the "high gain" system design to be impractical and that the second wing mode did not contribute significantly to gust loads, thus the mid-wing sensor locations were eliminated. This removal and relocation of the outer wing front beam accelerometer to the rear beam, caused a favorable influence on subsystem stability and allowed the maneuver and gust load control functions to be simply combined with reduced gains in the aileron channel.

Later a second accelerometer was placed in its present location on the front beam to minimize a 48 radian per second outer wing coupling mode that, in turn, increased the stability margins and eliminated an original need for complex notch filtering. Figure 8 indicates the effect of single and blended multiple accelerometer locations on the ALDCS aileron closed loop frequency response. The rear beam sensor permits an amplitude gain peak of 7 db at 48 radians per second. The addition of the front beam accelerometer adequately blended with the rear accelerometer to simulate the critical 48 radians per second node location, reduces this peak to approximately one db. An external wing accelerometer installation was considered; however, the additional cost and associated design risks eliminated this design.

Operational Flight Envelope -

To insure proper functioning of the ALDCS throughout the required flight envelope, gain scheduling and subsystem disengagement are necessary. The original subsystem mechanization required complex nonlinear scheduling interfaces with the central air data computer. As the development progressed these schedules were simplified to linear functions. Also an original ALDCS requirement for flaps down operation was deleted, thereby eliminating the need for flap gain schedules and automatic landing interfaces. These functions were replaced by a flaps down boundary logic control disengagement signal. Another change necessitated by flight envelope requirements was the development of a fader to smoothly disengage the subsystem when the airplane exceeds the boundary condition of normal acceleration, stall approach, and speed/Mach. Acceptable handling qualities were attained at these boundary conditions with a simple track and fade-out circuit in the elevator channel.

Subsystem Stability - Filter Compensation -

The problem of subsystem stability followed the mechanization development throughout the program in both the aileron and elevator channels. Perturbations in the mechanization occurred continually with the altering of filter compensation. Major modifications were the elimination of original design notch filtering and the additions of simple first order stability filters to improve a 2.4 Hertz stability margin in the aileron channel and the inclusion of a low pass stability and fuselage load control phasing filter in the elevator channel.

SUBSYSTEM PERFORMANCE

The ALDCS as mechanized has provided the load alleviation requirements without significantly interfering with airplane stability, handling qualities, autopilot performance or flight safety. The performance, as discussed in the following paragraphs, has been obtained utilizing existing C-5 aileron and in-board elevator control surfaces, without modification to the primary servo-actuators.

Maneuver and Gust Loads

The resulting ALDCS maneuver and gust loads performance data are summarized in figures 9 through 12. These performance results indicate that the incremental load relief meets the design criterion of attaining 30 percent bending moment reduction at the wing root, while not exceeding five percent torsional increase during continuous turbulence flight.

The steady maneuver incremental wing root load per 'g' ratios of ALDCS on to the basic aircraft are presented in figure 9. This summary covers a typical cruise payload configuration of 160,000 pounds and 94,250 pounds of fuel for a variation of Mach number and altitude. With ALDCS operative, these results indicate inner wing load reductions of 32 to 52 percent. The basic design goal ratio of 0.70 was achieved for all configurations within the normal C-5 operational speed, altitude and payload flight envelopes.

A typical wing root bending moment gust frequency response and PSD output spectrum are shown for the airplane with and without ALDCS in figure 10. The ALDCS gust output spectrum is significantly reduced from that of the free airplane. The transfer function shows that the first vertical wing bending mode amplitude at 0.9 Hz is reduced to approximately one-half with ALDCS operative. ALDCS control bandwidth encompasses primarily the short period and first wing bending airplane modes through the frequency of approximately one Hz.

Wing root RMS bending and torsional moment ratios of ALDCS on to ALDCS off, for a variation of altitude and Mach numbers, are given in figures 11 and 12. The ALDCS reduces the RMS wing root bending moments by 30 to 50 percent of the free airplane without increasing the torsional moment by more than the design goal of 5 percent for any case. The torsional moment is less than that of

the basic airplane for the majority of flight cases investigated.

Loads criteria for discrete gust were only specified to the extent that the ALDCS shall not increase the basic airplane discrete gust loads. Seven flight cases, similar to those presented in figure 9, were analyzed for the "1-cosine" discrete gust model. The wing root bending moment peaks, with ALDCS on, were reduced to values ranging from 78 to 52 percent of the free airplane for the critical gust frequency wavelengths.

Although no criteria were established for abrupt maneuver load control, analyses were conducted to evaluate the effect of ALDCS on abrupt maneuver load control characteristics. These analyses, conducted for seven selected flight conditions, revealed that the load reduction was from one to seventeen percent depending upon the particular flight case response characteristics. In an effort to improve this performance, a feedforward pitch control command signal was provided to the aileron channel. Results of analysis with the aileron feedforward signal for a selected number of cruise flight conditions indicated that the wing root bending moments could be reduced by 30 percent of the basic airplane. This feedforward signal mechanization was then incorporated in the ALDCS prototype system for flight test evaluation.

Fuselage loads performance was monitored during the continuous turbulence analysis to evaluate the effects of ALDCS. Results indicated that the aft fuselage bending moments were being increased up to 15% over the free airplane. A low-pass filter was added to the elevator channel that increased stability margins and decreased the aft body fuselage bending moments below those of the basic airplane for all cases.

Stability

The concern that the ALDCS possess adequate stability gain and phase margins caused considerable design optimization attention. This requirement was accomplished as indicated in figures 13 and 14. These gain and phase margins represent a series of reserve fuel loading cases that inherently possess the minimum aileron loop stability. The elevator loop stability is minimum with a high fuselage cargo loading, but in no cases were the phase margins less than 64 degrees or the gain margins less than 10 db.

The gain margins for both aileron and inboard elevator channels are well above the minimum requirement of 6 db for all cases.

The only flight case found to have the minimum phase margin of 45 degrees was that of a high altitude, reserve fuel and maximum ALDCS operational Mach number of 0.825. As fuel weight is added to this configuration, the aileron gain and phase margins are increased. A fuel capacity of approximately 30

percent for this case has a gain margin of 16.5 db and a phase margin of 62 degrees.

Minimum aileron gain and phase margins for all configurations occur at frequencies between 33 to 53 radians per second and between 6 and 17 radians per second, respectively. The minimum elevator gain margins for all configurations occur at frequencies between 6 and 8.6 radians per second with the phase margin frequencies ranging from 0.6 to 3.41 radians per second.

Handling Qualities

A basic ALDCS design goal was that there would be no significant degradation of the existing C-5 handling qualities. Extensive analysis and pilot-in-the-loop flight simulation evaluations were accomplished to insure that the ALDCS was compatible with the C-5 flying characteristics.

The handling quality areas of most concern that could be altered or significantly degraded by the ALDCS were:

- ° Maneuver response
- ° Accelerated stability-stick force per 'g'
- ° Short period stability
- ° Phugoid stability
- ° Roll performance

Development of an ALDCS elevator channel pilot command model filter was essential to retain the C-5 maneuver response and stick force per 'g' characteristics. ALDCS short period and phugoid stability effects were compensated by appropriate system gain and filter parameter optimization. The roll performance effect was greatly reduced by using the minimum aileron channel gain schedule required for maneuver load control.

The time histories shown in figure 15 present the effects of ALDCS on airplane normal C.G. acceleration and pitch rate responses for a typical pull-up maneuver. The input forcing function for this maneuver is a constant control force rate and hold after 3 seconds. This figure shows that the time to obtain steady-state maneuver values are practically the same with ALDCS off or on. The only difference with ALDCS on is that of a slight undershoot in peak pitch rate and a slight rise time improvement to acquire the steady state response. Simulator pilot evaluations of these type maneuvers indicated no degradation in airplane handling quality performance.

The longitudinal axis accelerated maneuvering stability, as shown in figure 16, was not significantly impaired by the ALDCS. The ALDCS stick force per 'g' values are well within the demonstrated boundaries of previously extracted

flight test data without ALDCS. The steady-state elevator command model gain was optimized to provide identical stick force per 'g' characteristics for mid C.G. flight configurations with ALDCS on or off. Pitch column force required to hold a given acceleration for forward and aft C.G. with ALDCS on are slightly decreased and increased, respectively from the basic airplane. The simulator pilots were unable to distinguish these ALDCS characteristics from those of the basic airplane.

No short period and phugoid stability damping degradation was noticed during the development flight simulation program and analytical results, as presented in figures 17 and 18, confirm the pilot evaluations. The original basic C-5 short period damping requirement for the cruise configuration was that it shall damp to one-tenth amplitude within one cycle. This requirement has been exceeded by the basic airplane and is slightly more damped with ALDCS operative.

The phugoid mode, as shown in figure 18 exhibits sufficient stability, although the frequency is slightly reduced from that obtained from previous flight test data correlation studies. The original C-5 phugoid stability requirement was that if the period is less than 15 seconds, then this mode shall be at least neutrally stable. Data shown in figure 18 does not indicate any frequencies with periods less than approximately 65 seconds with ALDCS on.

There was a concern early in the development program, that the ALDCS would reduce the C-5 roll performance. This concern arose primarily due to symmetrical control of ailerons with high acceleration gains that may cause actuator saturation. Theoretically, there is a slight decrease in available roll power due to aileron saturation; however, flight simulation evaluations determined that the pilots could not detect this degradation. For maximum roll rate maneuvers, the simulation pilots would mask ALDCS effects by commanding ailerons for a slight additional amount of time to perform the same maneuver.

The following handling qualities pilot opinions were attained during the ALDCS development and prototype Vehicle System Simulation Program.

- Ease of trimming to new speed - no degradation.
- Phugoid and short period damping - no degradation.
- Roll power - no noticeable degradation.
- Stick force per 'g' characteristics - no degradation.
- ALDCS fails to switch off - no degradation with flap extension.

A total of six pilots, including two from the Air Force, flew the development simulator with ALDCS on and off.

The effect of ALDCS on the C-5 handling qualities can be summarized by the fact that the simulation pilots were unable to detect whether the ALDCS was on or off during evaluations within the normal flight envelope.

Autopilot Compatibility

The ALDCS is designed to be engaged during autopilot operation, thus considerable design attention was directed to subsystem compatibility. This development was concentrated on autopilot interface stability, response performance and flight safety. It was found necessary that the ALDCS elevator channel control signals of pitch rate and pilot's feedforward command be disengaged during autopilot operation. Elimination of these control signals during autopilot operation improved the stability margins and minimized control wheel steering sensitivity, and airplane acceleration response due to an autopilot hardover failure.

Results indicate no apparent degradation in either stability or response of the autopilot attitude, altitude hold or control wheel steering modes. The effect of ALDCS on autopilot altitude hold and roll performance was insignificant with the airplane achieving limit bank angle with minimum altitude loss. Pitch autopilot hardover failures, with ALDCS engaged, yield a normal acceleration response slightly below that of the basic airplane and autopilot.

Flight Safety

To insure that ALDCS faults would not affect the C-5 flight safety, failure effects analysis and prototype vehicle system simulation evaluations were accomplished. These failures involved loss of ALDCS sensor signals, loss of ALDCS, hardovers of sensors and channel loop commands, gain schedule failures, and various stability augmentation subsystem (SAS) failures that could be effected by the ALDCS.

The analysis and simulator testing indicates that the ALDCS adequately meets the safety requirements and criteria. There is sufficient subsystem stability should any one sensor or channel in the ALDCS be lost. Neither of the various SAS failures were worse than those of the existing system; however, some failure detection and airplane transient improvement was exhibited with ALDCS operative.

Results of these studies indicated that there were no single ALDCS or automatic flight control interface failures that caused pilot concern. Adequate fault detection and annunciation of these failures was apparent to the pilot. The ALDCS has met the basic safety criteria and is acceptable for prototype development flight testing.

Ride Control

No real attempt was made during the ALDCS development program to improve the C-5 ride control characteristics. The pilot's station acceleration levels were monitored throughout the continuous turbulence analysis however, to insure that the ride quality was not adversely affected by the ALDCS.

Results of these analyses revealed that the pilot's acceleration levels were reduced by 7 to 35 percent throughout the C-5 ALDCS flight envelope.

CONCLUDING REMARKS

A prototype maneuver and gust load alleviation control system has been successfully developed, fabricated and simulator tested meeting demanding schedules and functional requirements. It is felt that a major airplane active control subsystem integration accomplishment has been achieved by integrating the ALDCS into the total C-5 Vehicle System while maintaining compatibility with existing airplane stability, handling qualities, and flight control subsystems. While no specific requirements were established, it is noteworthy that the ALDCS has favorably influenced the pilot station accelerations (ride control), abrupt maneuver load control, aft fuselage gust loads, and some failure detection levels of interfacing automatic flight control subsystems.

Now as the Active Lift Distribution Control Subsystem enters development flight test evaluations the development engineers and the design personnel from the affected disciplines confidently feel that the subsystem will continue to meet its design objectives. These design engineers have integrated their experience, development techniques, and computer programs to meet a very restrictive schedule. The success of this development program can largely be attributed to the fact that the prototype systems were primarily designed and fabricated within the structure of one company.

It is planned, if successful in flight test, that the ALDCS be produced and retrofitted to the C-5 fleet. This ALDCS development program, even though it is not a true preliminary design application of active control technology, has provided an understanding of the problems facing the designer and the experience and design techniques needed to apply active controls to aircraft of the future.

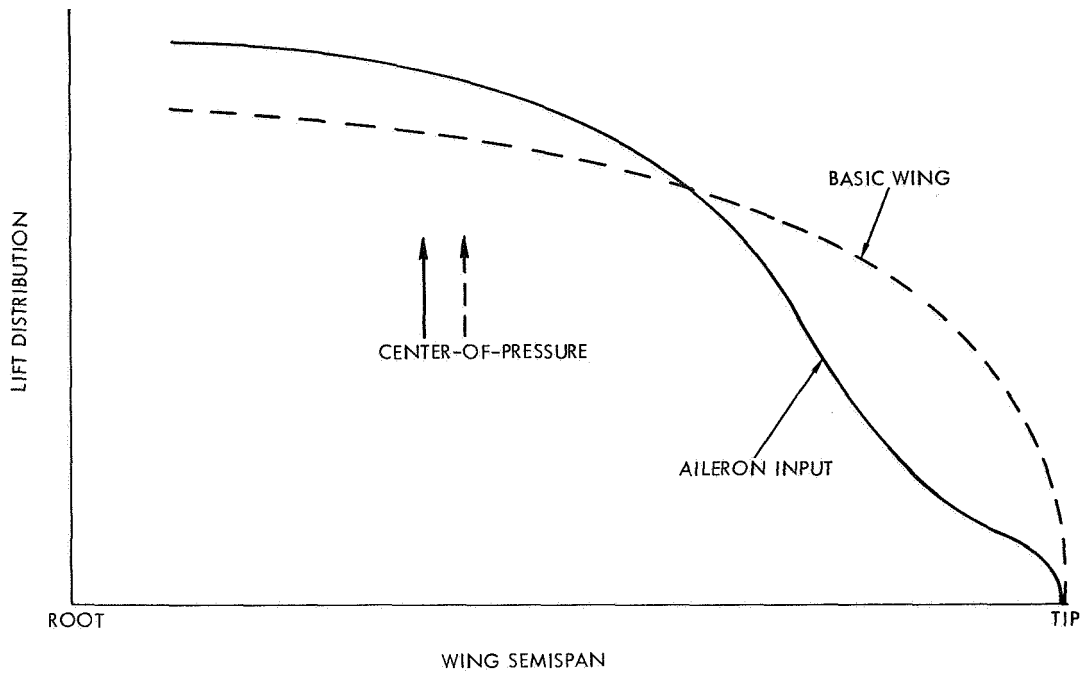

Figure 1.- Effect of aileron control on C-5 wing lift distribution.

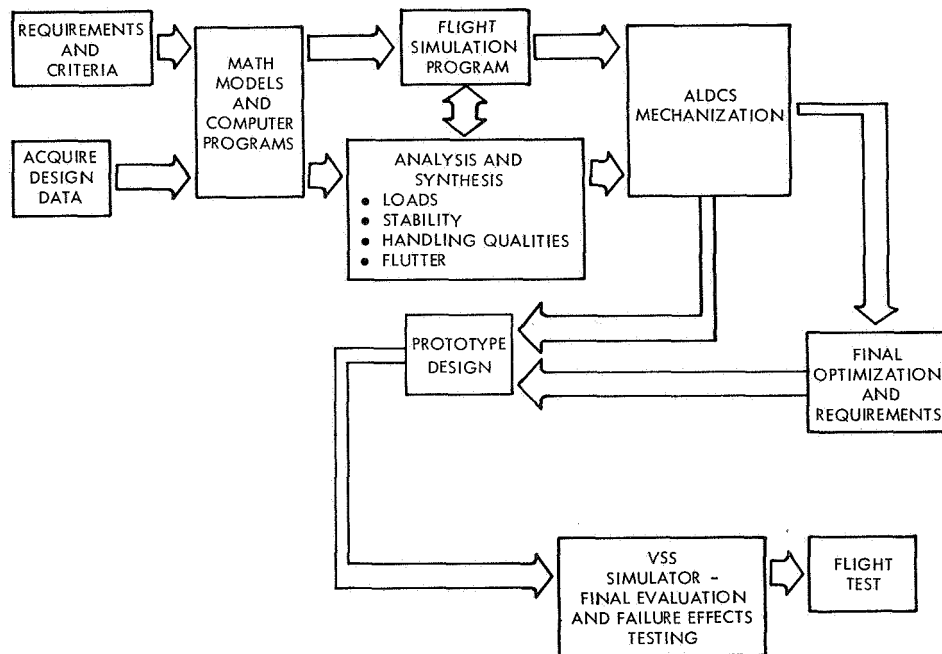

Figure 2.- C-5 ALDCS development program flow diagram.

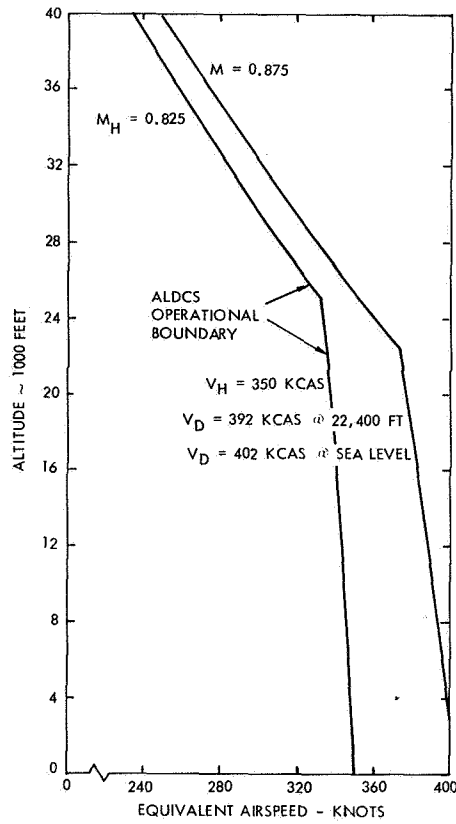

Figure 3.- C-5 ALDCS speed altitude envelope.

PHASE	MAJOR TASKS	1973												1974											
		M	J	J	A	S	O	N	D	J	F	M	A	M	J	J									
A	SYSTEM ANALYSIS AND SYNTHESIS	GO-AHEAD 5-7 90% MECH. ▽ 9-21																							
	PROTOTYPE DESIGN AND FABRICATION	△ 11-7 FINAL MECH. ▽ FIRST PROTOTYPE																							
	FLIGHT SIMULATION	DEV. SIMULATION						VSS																	
B	FLIGHT TEST													FIRST FLIGHT 3-15 7-19											
C	PRODUCTION DESIGN AND FABRICATION	PENDING FULL GO-AHEAD (TENTATIVE 7-1-74) INTERIM GO-AHEAD 3-1-74																							
D	FLEET UPDATE	PENDING GO-AHEAD (TENTATIVE 6-1-75)																							

Figure 4.- C-5 ALDCS development program schedule milestones.

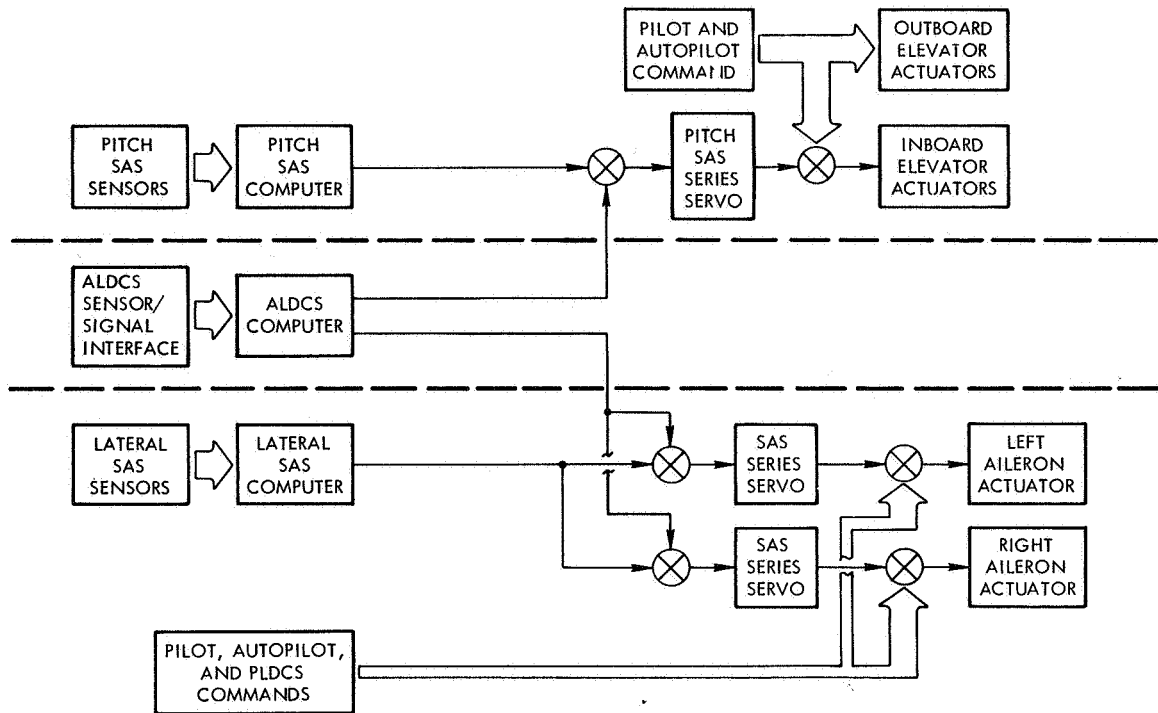

Figure 5.- ALDCS flight control system interface diagram.

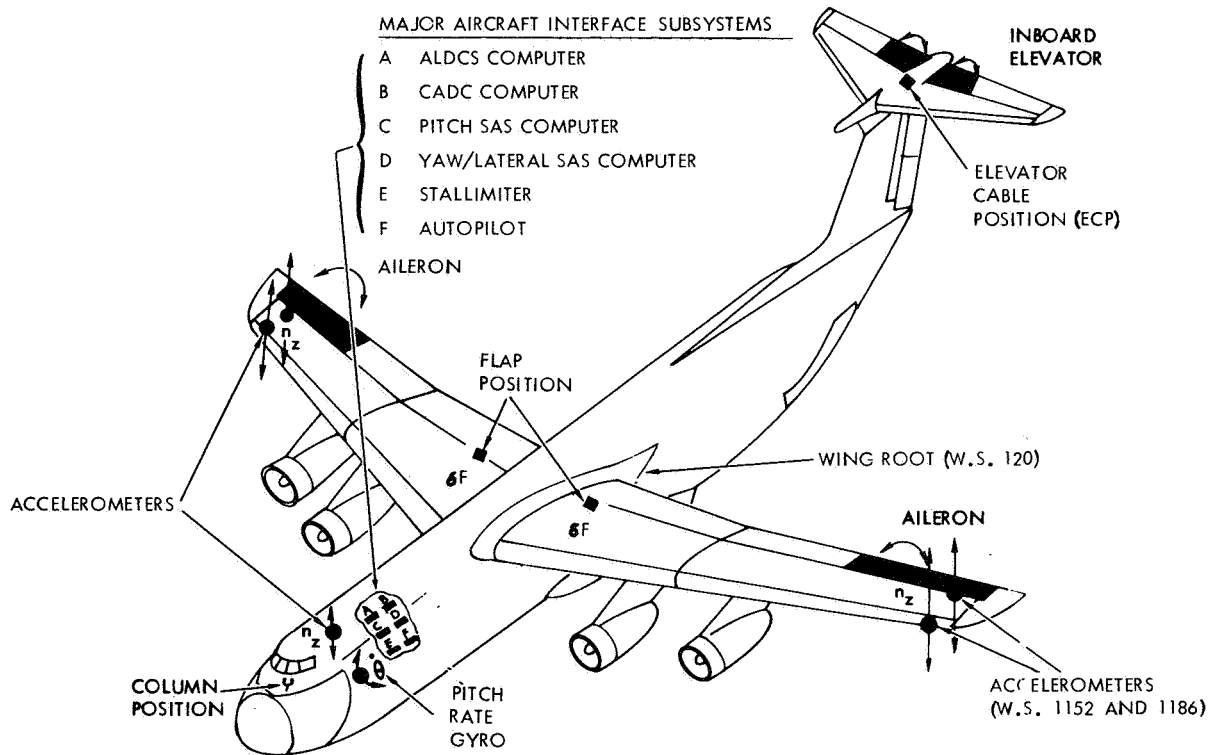

Figure 6.- C-5 ALDCS major airplane components interface.

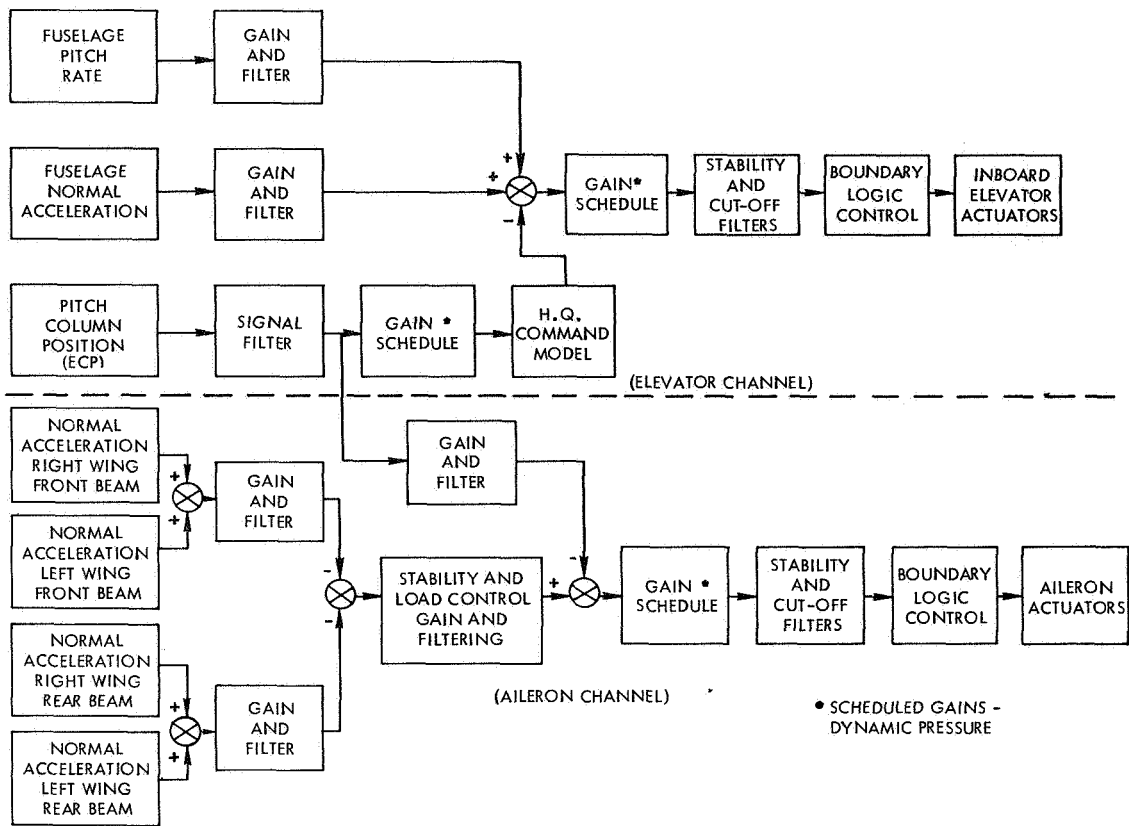

Figure 7.- C-5 ALDCS simplified functional block diagram.

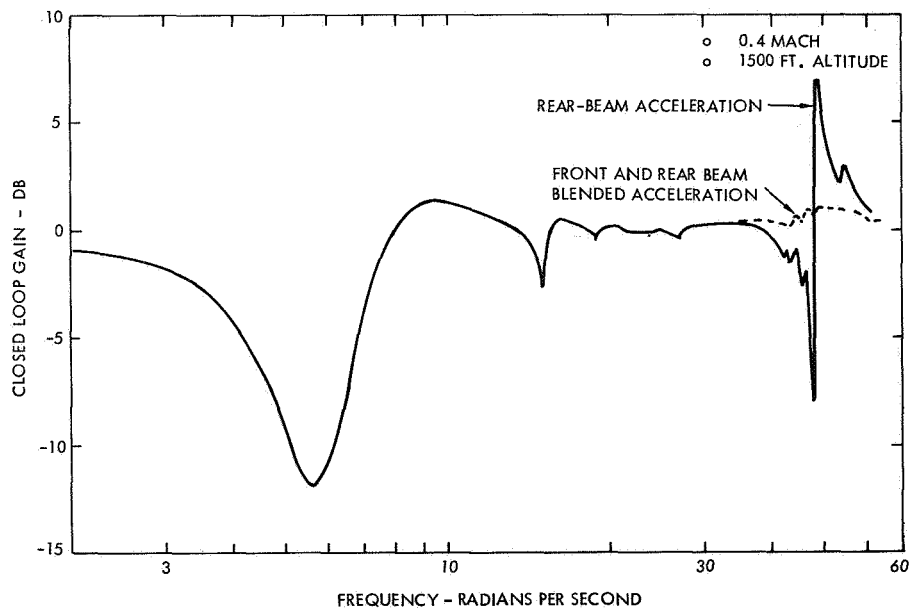

Figure 8.- C-5 ALDCS aileron closed-loop frequency response.

FUEL WEIGHT 94,250 LB

CARGO WEIGHT 160,000 LB

ALTITUDE (FEET)	MACH	$\frac{\Delta M_x/G \text{ (ALDCS)}}{\Delta M_x/G \text{ (NO ALDCS)}}$
SEA LEVEL	0.30	0.55
SEA LEVEL	0.40	0.48
SEA LEVEL	0.50	0.52
12,000	0.40	0.64
12,000	0.50	0.58
12,000	0.60	0.55
26,000	0.60	0.67
26,000	0.70	0.66
26,000	0.75	0.65
40,000	0.72	0.68
40,000	0.77	0.63
40,000	0.82	0.61

FIGURE 9. - C-5 ALDCS WING ROOT BENDING MOMENT RATIOS - STEADY MANEUVER

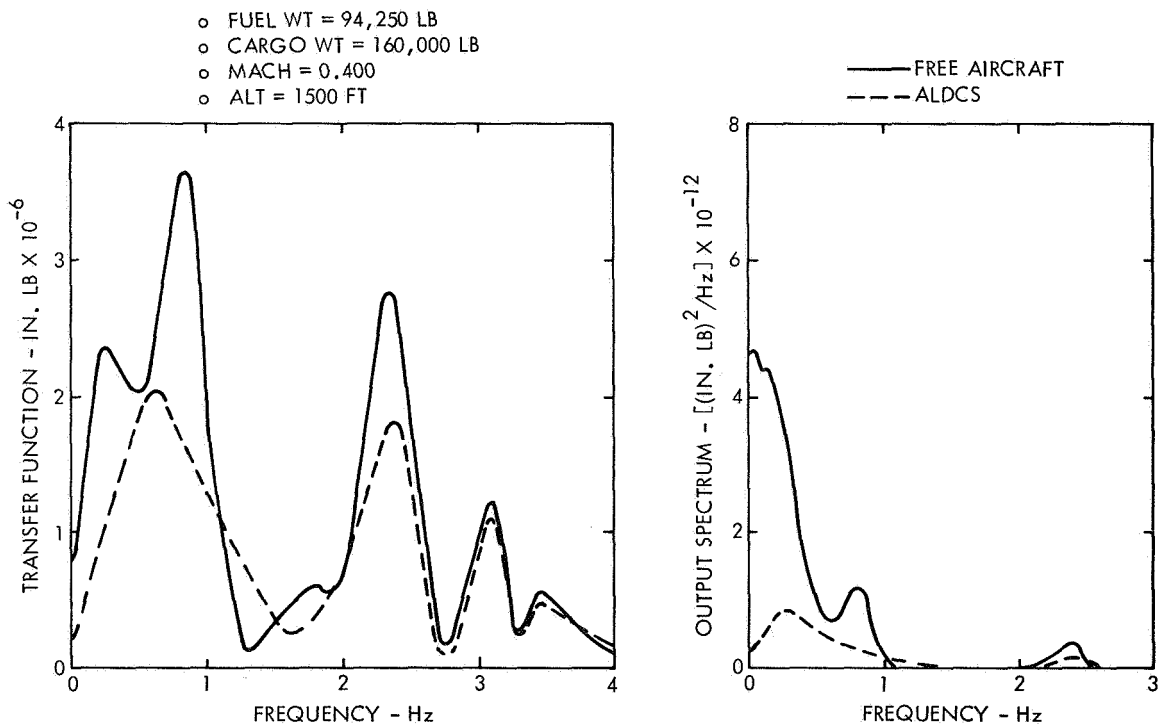

Figure 10.- C-5 ALDCS wing root bending moment - 1 fps RMS vertical gust.

FUEL WEIGHT 94,250 LB
 CARGO WEIGHT 160,000 LB

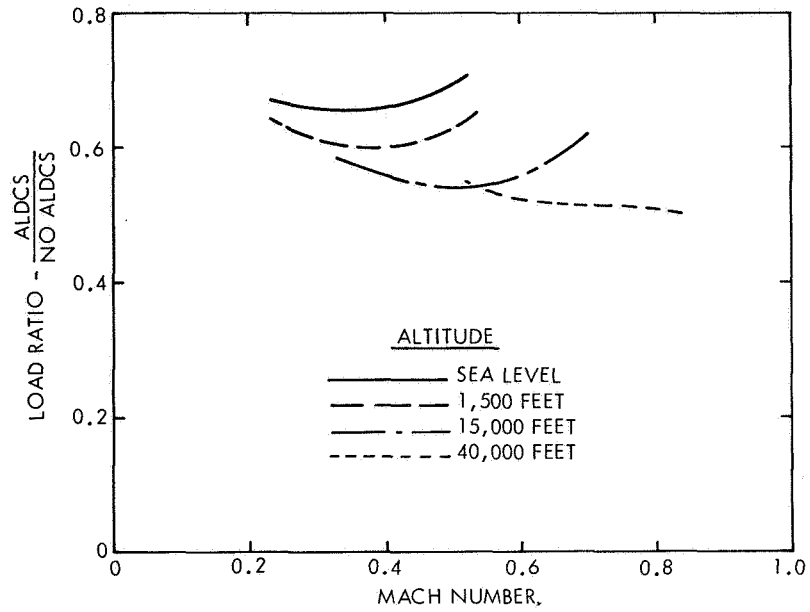

Figure 11. - C-5 ALDCS wing root gust RMS bending moment ratio.

FUEL WEIGHT 94,250 LB
 CARGO WEIGHT 160,000 LB

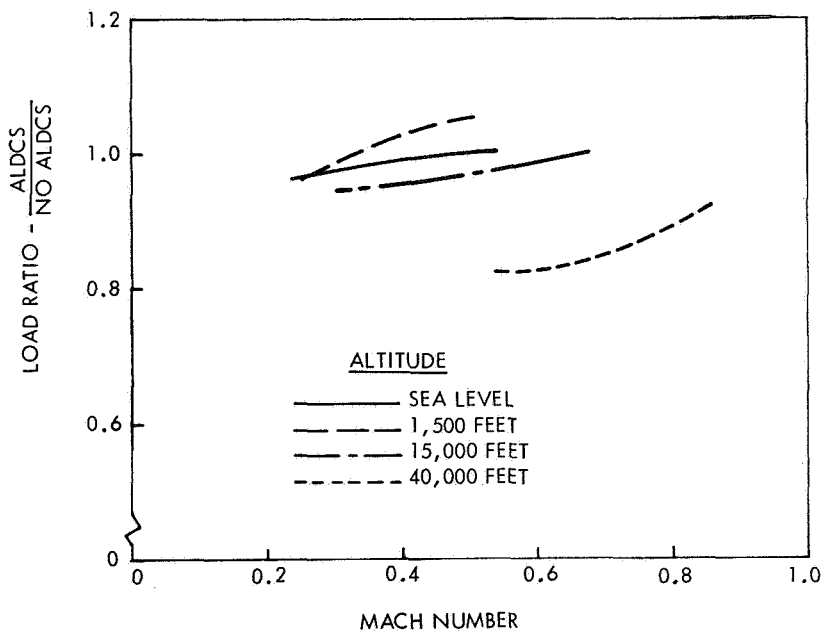

Figure 12. - C-5 ALDCS wing root gust RMS torsion moment ratio

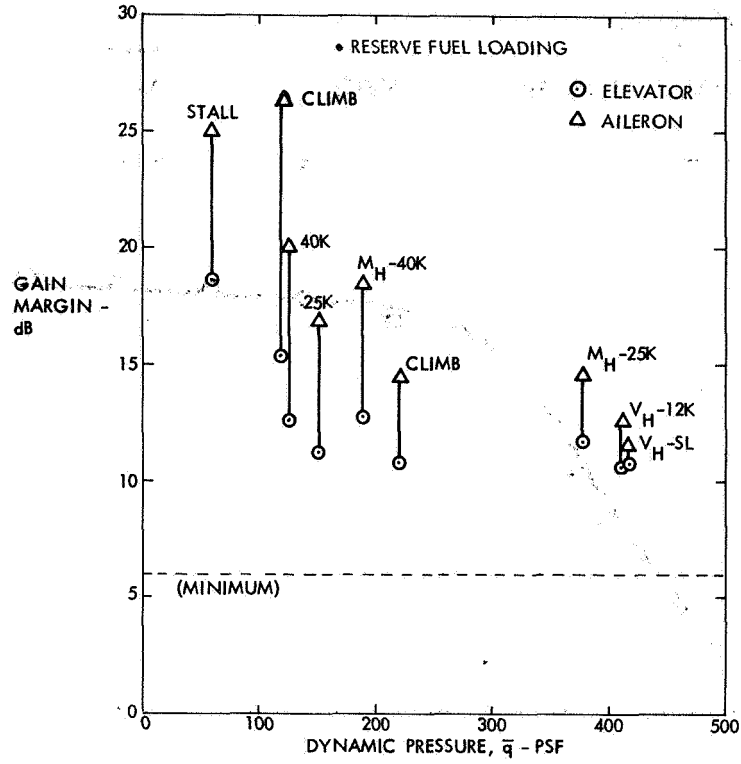

Figure 13.- C-5 ALDCS stability gain margins.

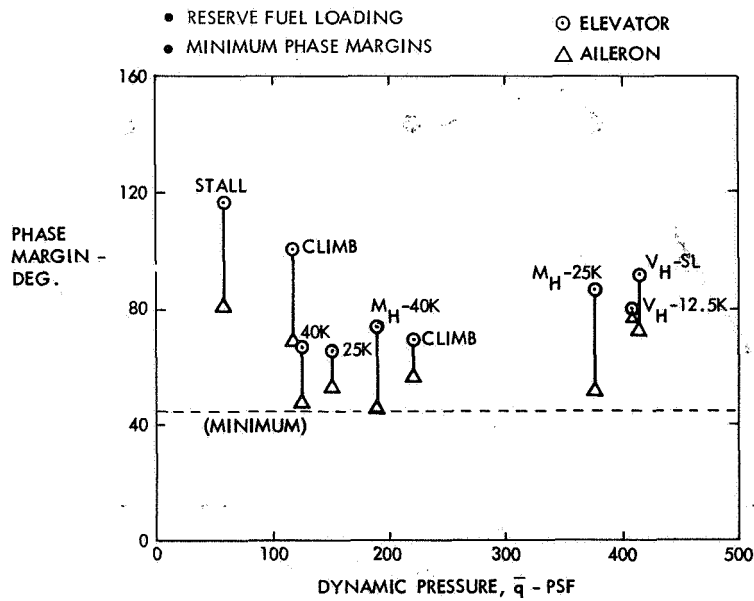

Figure 14.- C-5 ALDCS stability phase margins.

- 240 KCAS
- MID CG
- ELEVATOR RAMP/HOLD INPUT
- ALDCS OFF
- ALDCS ON

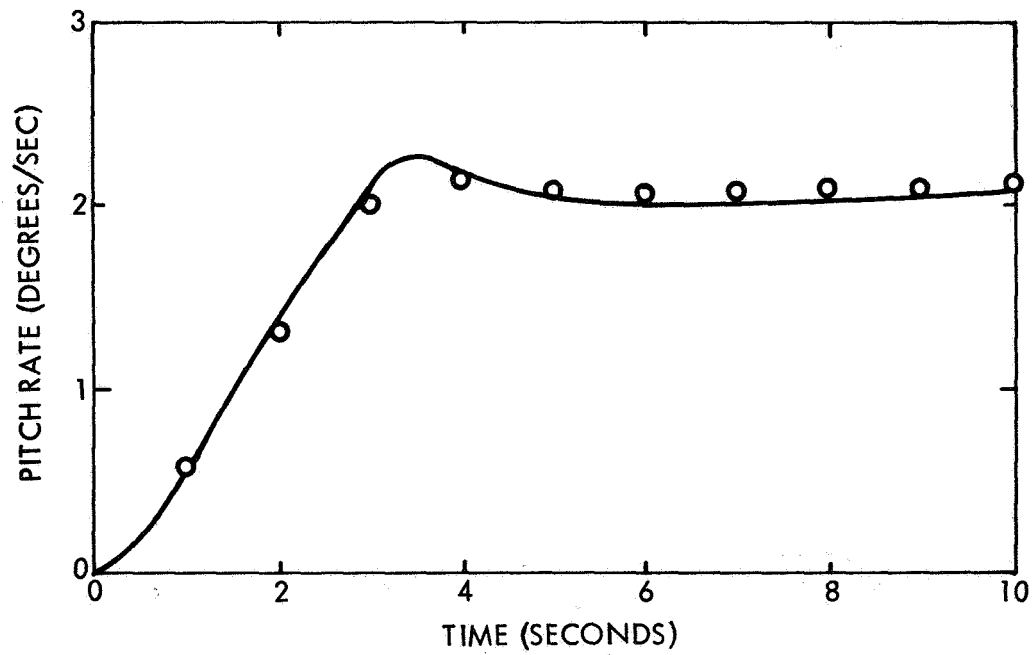
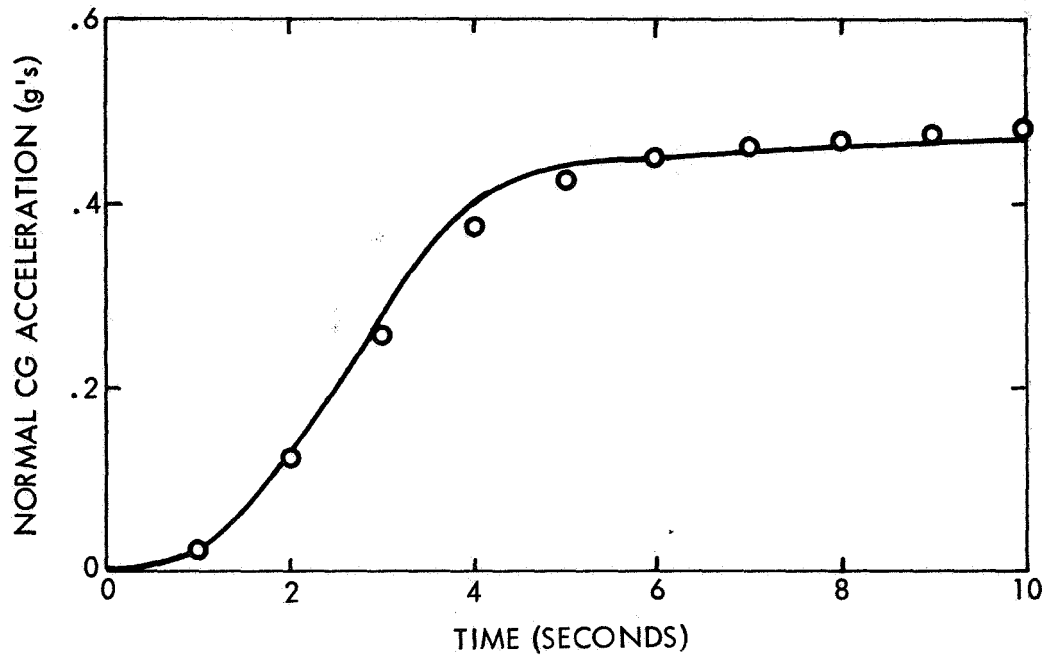

Figure 15.- C-5 ALDCS symmetric pull-up time history.

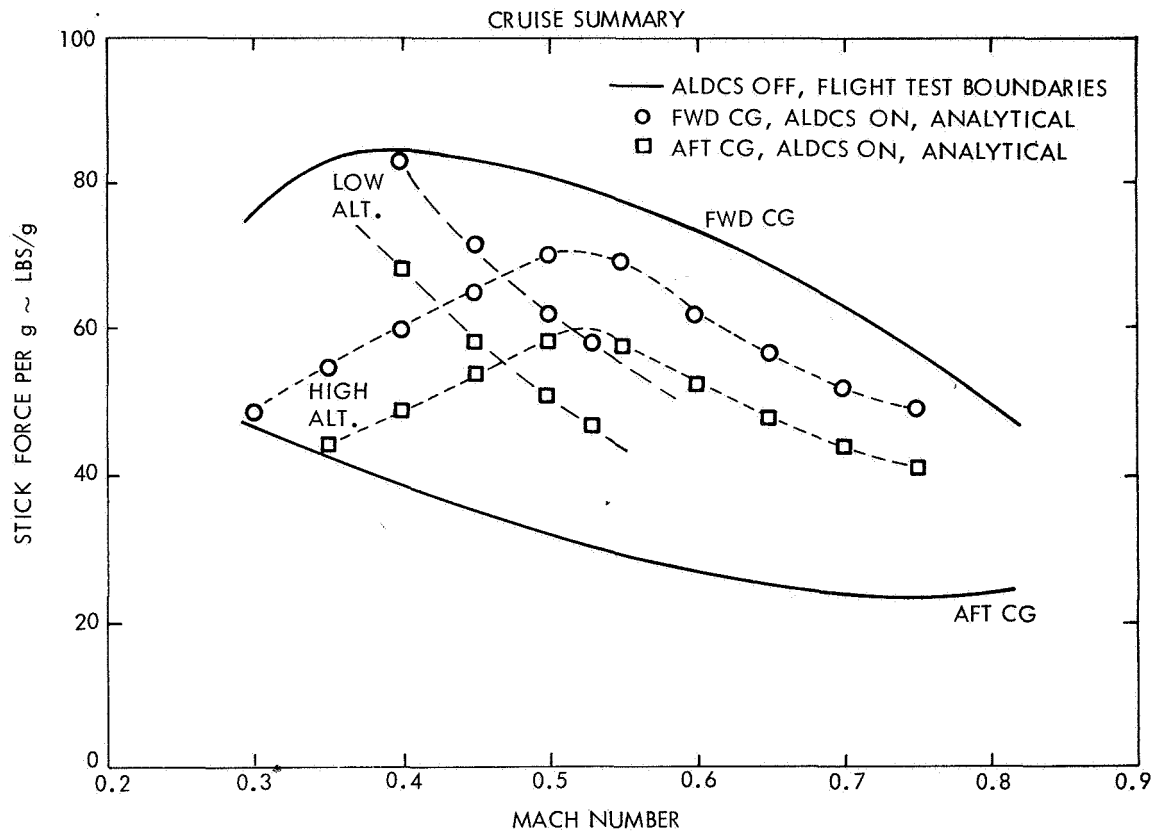

Figure 16.- C-5 ALDCS maneuvering longitudinal axis stability - Stick force per g.

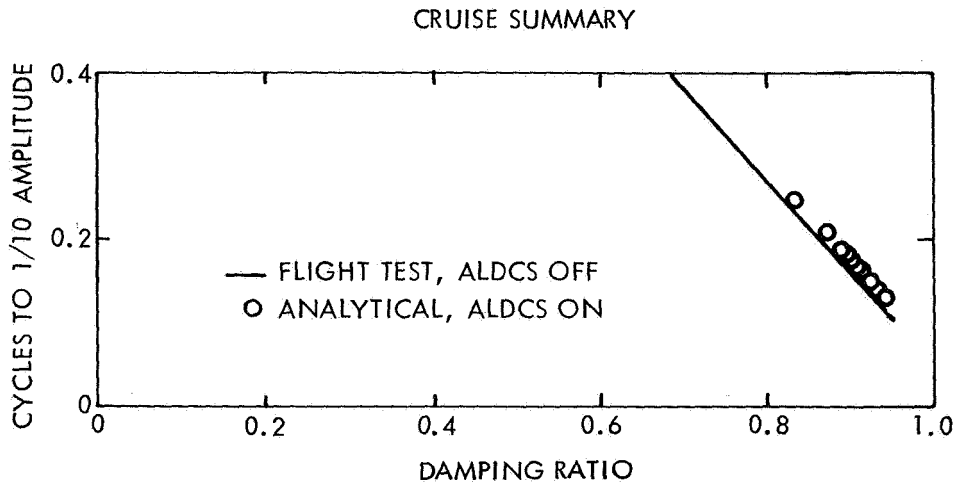

Figure 17.- C-5 ALDCS short period stability.

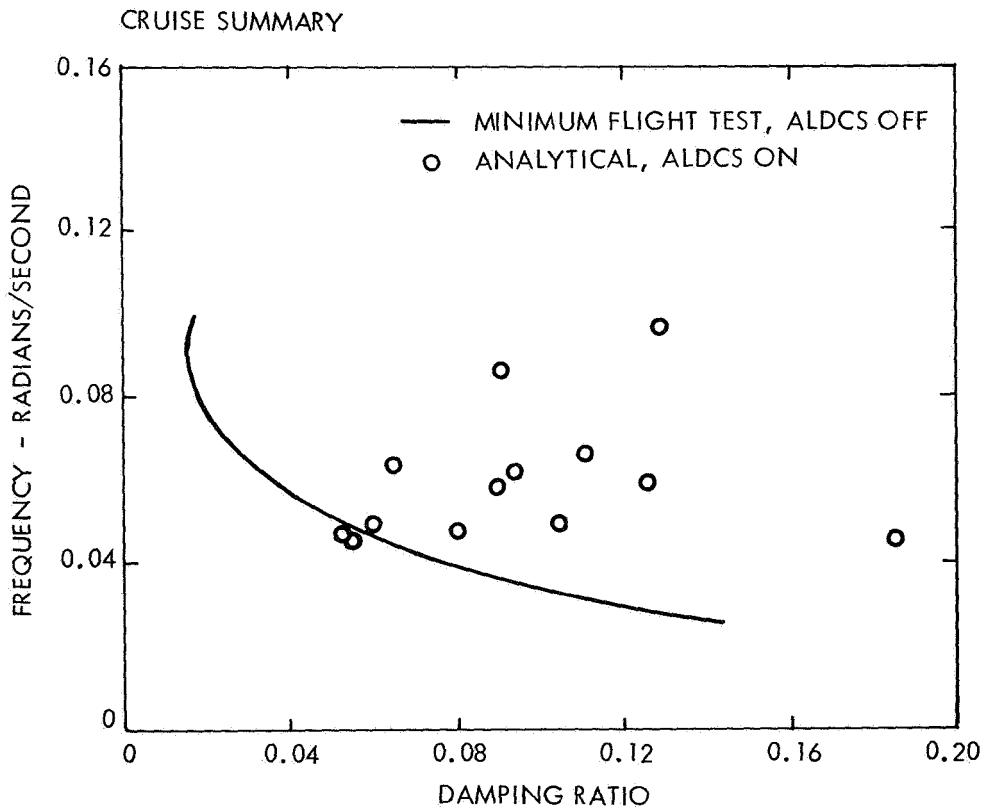

Figure 18.- C-5 ALDCS phugoid stability.