

## **General Disclaimer**

### **One or more of the Following Statements may affect this Document**

- This document has been reproduced from the best copy furnished by the organizational source. It is being released in the interest of making available as much information as possible.
- This document may contain data, which exceeds the sheet parameters. It was furnished in this condition by the organizational source and is the best copy available.
- This document may contain tone-on-tone or color graphs, charts and/or pictures, which have been reproduced in black and white.
- This document is paginated as submitted by the original source.
- Portions of this document are not fully legible due to the historical nature of some of the material. However, it is the best reproduction available from the original submission.

04

"Made available under NASA sponsorship  
In the interest of early and wide dissemination of Earth Resources Survey  
Program information and without liability  
for any use made thereof."

7.0-10.497 III  
CR-148803

CORRELATION OF CHLOROPHYLL, SUSPENDED MATTER, AND  
RELATED PARAMETERS OF WATERS IN THE LOWER  
CHESAPEAKE BAY AREA TO LANDSAT-1 IMAGERY

(E76-10497) CORRELATION OF CHLOROPHYLL,  
SUSPENDED MATTER, AND RELATED PARAMETERS OF  
WATERS IN THE LOWER CHESAPEAKE BAY AREA TO  
LANDSAT-1 IMAGERY Final Report, Aug. 1972 -  
Nov. 1974 (Old Dominion Univ. Research

N76-32611  
HC \$6.00

Unclas  
G3/43 00497

Peter Fleischer, Thomas A. Gosink, William J. Hanna,  
John C. Ludwick, David E. Bowker, and William G. Witte

Prepared by the  
OLD DOMINION UNIVERSITY RESEARCH FOUNDATION  
NORFOLK, VIRGINIA

August 1976  
Final Report for Period August 1972 - November 1974

1299B

Prepared for  
GODDARD SPACE FLIGHT CENTER  
GREENBELT, MARYLAND

RECEIVED

SEP 13 1976

SIS/902.6

1. Report No.	2. Government Accession No.	3. Recipient's Catalog No.	
4. Title and Subtitle CORRELATION OF CHLOROPHYLL, SUSPENDED MATTER, AND RELATED PARAMETERS OF WATERS IN LOWER CHESAPEAKE BAY AREA TO LANDSAT-1 IMAGERY		5. Report Date August 1976	6. Performing Organization Code
		8. Performing Organization Report No.	
7. Author(s) P. Fleischer, D.E. Bowker,* W.G. Witte*, T.A. Gosink, W.J. Hanna, J.C. Ludwick		10. Work Unit No.	
9. Performing Organization Name and Address Old Dominion University Research Foundation Norfolk, VA 23508		11. Contract or Grant No. NAS5-21816	
		13. Type of Report and Period Covered Final August 1972 - November 1974	
12. Sponsoring Agency Name and Address National Aeronautics and Space Administration Goddard Space Flight Center Greenbelt, MD 20771		14. Sponsoring Agency Code	
15. Supplementary Notes  * NASA Langley Research Center			
16. Abstract  An effort to relate water parameters of the lower Chesapeake Bay area to multispectral-scanner images of LANDSAT-1 has shown that some spectral bands can be correlated to water parameters, and has demonstrated the feasibility of synoptic mapping of estuaries by satellite. Water data was collected for one year at the time of LANDSAT-1 overpasses. Bands 5 and 6 of the MSS were shown to be useful for monitoring total particles. Band 5 showed high correlation with suspended sediment concentration. Attenuation coefficients monitored continuously by ship along three baselines were cross-correlated with radiance values on three days. Improved correlations resulted when tidal conditions were taken into consideration. A contouring program was developed to display sediment variation in the lower Chesapeake Bay from the MSS bands.			
17. Key Words (Selected by Author(s))  Remote Sensing, Suspended Matter, Chlorophyll, LANDSAT-1		18. Distribution Statement	
19. Security Classif. (of this report)  UNCL	20. Security Classif. (of this page)  UNCL	21. No. of Pages  125	22. Price*

\*For sale by the Clearinghouse for Federal Scientific and Technical Information, Springfield, Virginia 22151.

## PREFACE

The objective of this work was to determine the degree to which estuarine water parameters of the lower Chesapeake Bay area could be correlated to LANDSAT-1 multispectral imagery; and using successful correlation, demonstrate the feasibility of constructing synoptic water-parameter maps directly from satellite imagery. Chlorophyll, particulate counts, attenuation coefficients and suspended matter of surface waters were measured over a one-year period by helicopter and ship synchronous with satellite overpasses. Bands 5 and 6 of the multispectral scanner were shown to be useful for monitoring total particles, although daily calibration was required. Band 5 showed a high correlation with suspended sediment concentration, and under some conditions an internal correction for atmospheric interference was possible. The relation of sediment to particles was established with MSS radiance values, since the two parameters were not monitored at the same stations. Attenuation coefficients monitored continuously by ship along three baselines were cross-correlated with radiance values on three days. Evidence for tidal effects was obtained by improved correlations when the ship data was adjusted to "tidal time." A contouring program was developed to display a synoptic map of suspended sediment concentration in the lower Chesapeake Bay for one overpass. In view of the fact that LANDSAT-1 was not optimized for collection of estuarine water parameters, the favorable results of these correlations indicate that the approach demonstrated here is quite feasible and capable of considerable refinement.

## TABLE OF CONTENTS

	Page
INTRODUCTION . . . . .	1
DATA COLLECTION . . . . .	2
Water Parameters and Sampling Plan . . . . .	2
Sampling and Storage for Chlorophyll and Particulate Counts . . . . .	3
Chlorophyll Analysis . . . . .	5
Particle Count Analysis . . . . .	6
Turbidity Analysis . . . . .	7
Bathymetry Analysis . . . . .	8
Suspended Sediment . . . . .	8
Salinity and Temperature . . . . .	9
DATA ANALYSIS . . . . .	10
Correlation Between Water Parameters . . . . .	10
Correlation of MSS Data With Water Parameters . . . . .	17
Particles . . . . .	17
Chlorophyll . . . . .	25
Sediment . . . . .	26
Variables Influencing Sediment . . . . .	30
Analysis of Baseline Data . . . . .	35
SUMMARY AND CONCLUDING REMARKS . . . . .	43
APPENDIX A. Helicopter Station Locations by Date . . . . .	46
APPENDIX B. Method of Chlorophyll Analysis of Strickland and Parsons - Amended . . . . .	60
APPENDIX C. Chlorophyll Analyses . . . . .	66
APPENDIX D. Particle Count Analyses . . . . .	82
APPENDIX E. Description of Transmissometer System . . . . .	98
APPENDIX F. Attenuation-Coefficient Profiles . . . . .	104
APPENDIX G. Bathymetric Profiles . . . . .	119
APPENDIX H. Water-Sample Parameters, Samples Collected from R/V LINWOOD HOLTON . . . . .	122
REFERENCES . . . . .	125

## LIST OF ILLUSTRATIONS

		Page
Figure 1.	Location map of lower Chesapeake Bay-James River area. . . . .	4
Figure 2.	Location of sampling stations. . . . .	11
Figure 3.	Linear regression plot for sediment versus attenuation coefficient including data for all days. . . . .	16
Figure 4.	Linear regression plot of average sediment versus average histogram mean. . . . .	18
Figure 5.	Bands (5-6) radiance versus total particles for Jan 26. . . . .	20
Figure 6.	Bands (5-6) radiance versus total particles for Feb 13. . . . .	21
Figure 7.	Bands (5-6) radiance versus total chlorophyll for Jan 26. . . . .	23
Figure 8.	Bands (5-6) radiance versus total chlorophyll for Feb 13. . . . .	24
Figure 9.	Linear regression plots for bands (5-6) particle radiance error versus chlorophyll for given dates including data for Jan 26. . . . .	27
Figure 10.	Linear regression plots for band 4 chlorophyll radiance error versus total particles for given dates including data for Jan 26. . . . .	28
Figure 11.	Band 5 radiance versus sediment for given dates. . . . .	32
Figure 12.	Band 5 radiance versus attenuation coefficient for given dates. . . . .	33
Figure 13.	Linear regression plots for sediment versus particles for given dates including wind velocity. . . . .	34
Figure 14.	Linear regression plot for average sediment versus 3-day average resultant wind velocity. . . . .	36
Figure 15.	Sediment contour map of the lower Chesapeake Bay area for Jan 26. . . . .	37
Figure 16.	Plots of radiances (4 bands) and attenuation coefficient measured along baseline 1 for Jan 26. . . . .	39
Figure 17.	Correlation coefficients between band 4 radiance and attenuation coefficient plotted as a function of time between LANDAT-1 overpass and mean ship transect time. . . . .	40
Figure 18.	Position of tide during ship transects along three baselines at mean baseline time for given days and at time of LANDSAT-1 overpass on 8 days. . . . .	41

	Page
Figure 19. Plot of attenuation coefficient along baseline 3 as a function of tidal cycle. . . . .	42

LIST OF TABLES

Table 1. Record of sample collection and analysis of MSS tapes. . . . .	12
Table 2. Correlation coefficients for helicopter sample variables. . . . .	13
Table 3. Correlation coefficients for ship sample variables. . . . .	14
Table 4. Correlation coefficients and linear regression equations for total particles. . . . .	19
Table 5. Correlation coefficients and linear regression equations for total chlorophyll. . . . .	22
Table 6. Correlation coefficients and linear regression equations for sediment. . . . .	29
Table 7. Corrected gray scale histogram maximums for lower Chesapeake Bay water pixels. . . . .	31
Table 8. Correlation coefficients between band 4 radiance and baseline alpha for given dates and nearest tidal cycle dates. . . . .	44

## INTRODUCTION

The synoptic monitoring of water parameters in large estuaries is a useful and important approach to the solution of practical and scientific problems associated with these water bodies. The synoptic data thus gained can be used to determine long- and short-term circulation patterns which aid in the description and assessment of estuarine circulation models. Sediment sources, dispersal, and sedimentation patterns can be delineated, and spatial-temporal productivity variations detected. Thus, synoptic monitoring is an analytical and predictive tool of considerable environmental, scientific, and economic merit. Synoptic monitoring of large estuaries, however, is extremely difficult to perform by conventional methods because of logistical problems and cost. Hence, it is of considerable interest to test the extent to which it is feasible to apply satellite imagery to this effect. The purpose of this work was to determine which estuarine water parameters can be correlated to LANDSAT-1 imagery; and where high correlations exist, demonstrate the feasibility of constructing synoptic water-parameter maps directly from LANDSAT-1 imagery.

LANDSAT-1 serves as an excellent tool for such an evaluation for several reasons. First, its four-band multispectral scanner permits general spectral discrimination of estuarine water parameters. Second, the 185- by 185-km image area is large enough to encompass even large estuaries in one image. Third, its 18-day cycle is short enough so that seasonal and even shorter-term variations can be resolved.

In this work, the lower Chesapeake Bay-James River system was the area used to examine the correlation of water parameters to satellite imagery. This area is ideally suited to such a comparison. The Chesapeake Bay is a very large, complex estuary with a variety of major inputs, such as the James River; a wide range of environments, from natural on the Eastern Shore to intensely urbanized Hampton Roads, and in which mixing of waters is dominated by strong tidal currents. Two principal water characteristics, productivity and suspended material, were selected for correlation. These characteristics were each measured by a number of separate water parameters. Measurement was based on spot samples collected by helicopter and baseline transects obtained by surface vessel. Sea-truth



collection was synchronized with satellite overpasses, and was made over a one-year period. The water parameters were then correlated to the multispectral bands of the satellite imagery, and correlations optimized by correction and combination. Ultimately, a synoptic water-parameter map could be generated from the imagery by the sea-truth calibration.

## DATA COLLECTION

### Water Parameters and Sampling Plan

The water parameters measured for correlation with satellite imagery were selected by two principal criteria. First, the parameters had to affect the character of the water such that they could be detected by satellite, i.e. variations in the parameters must directly or indirectly cause spectral changes in the radiance of the water. Second, the parameters had to be those that are commonly used in estuarine studies and monitoring, and they had to be readily measurable by standard methods.

The water parameters thus selected fall into four groups; productivity, particulate matter, depth, and water density. The measure of productivity used was chlorophyll, which is a measure of phytoplankton concentration. Total chlorophyll as well as chlorophyll A, B, C, and carotene were determined. Particulate matter was measured by three methods; concentration, particle count, and turbidity. Concentration was measured as mass per unit volume of water and is a measure of total suspended solids. Particle counts were made with relation to size and are a measure of the particle size distribution. Water turbidity was measured by light transmission and is principally a function of the suspended particulate matter. In shallow estuaries, light reflected from the bottom can be an indicator of depth, but is also related to turbidity. Water density parameters were measured as temperature and salinity. Although these cannot be directly measured by radiance, they are related to the source of the water and thus to its characteristic biologic and particulate properties. This aspect is particularly important in estuaries, where runoff and oceanic water are often mixed by strong tidal currents.

The sampling plan was designed to obtain on a synoptic basis with respect to the satellite overpasses a large number of measurements of the abovementioned water parameters. Because of the size of the lower Chesapeake Bay-James River

system and obvious physical limitations, the intent was to approximate the synoptic sampling, and to obtain this information on a consistent basis as often as possible. To achieve this most measurements were made at known fixed locations or lines.

Two sampling platforms were employed simultaneously during a satellite overpass; a helicopter, and the R/V LINWOOD HOLTON, a 66-foot, converted Army T-boat. Water was sampled from the helicopter at 18 principal locations (Figure 1) during satellite overpasses. Sampling was usually completed within an hour of the overpass, and synoptic conditions were well-approximated. On several occasions, additional samples were collected by helicopter, particularly seaward of the Chesapeake Bay entrance (Figure 1). All helicopter sample locations are tabulated in Appendix A. Water parameters obtained from the helicopter sampling were chlorophyll and particle counts.

During an overpass, the HOLTON traversed a triangular course of three baselines in the lower Chesapeake Bay (Figure 1). The vessel traversed the baselines without stops at a speed of 11-14 km/hr. Most baselines were completed within three hours of an overpass, but occasionally this had to be extended to six hours. The HOLTON also traversed the James River twice and the area off the Chesapeake Bay entrance once (Figure 1). The principal purpose of the baseline traverses was to obtain continuous, near-surface turbidity profiles. Continuous bathymetric profiles were also obtained along the three baselines. While the ship was on the baselines, underway surface-water samples were collected at eight locations (Figure 1). These samples were used for suspended-sediment concentration, temperature, and salinity determinations.

#### Sampling and Storage for Chlorophyll and Particulate Counts

Sampling was done from a helicopter so as to cover the test site in nearly real time and to be able to return to the laboratory to start analysis before noticeable changes occur in samples.

A 10-liter plastic bucket was lowered from the helicopter (from about 2 to 4 feet altitude) to collect samples. A clean 500-cc collection bottle was rinsed twice and then filled with sample, and then transferred to a dark 2-liter polyethylene bottle in a covered box mounted on the helicopter. This was repeated three more times per station at locations approximately 1000 feet around

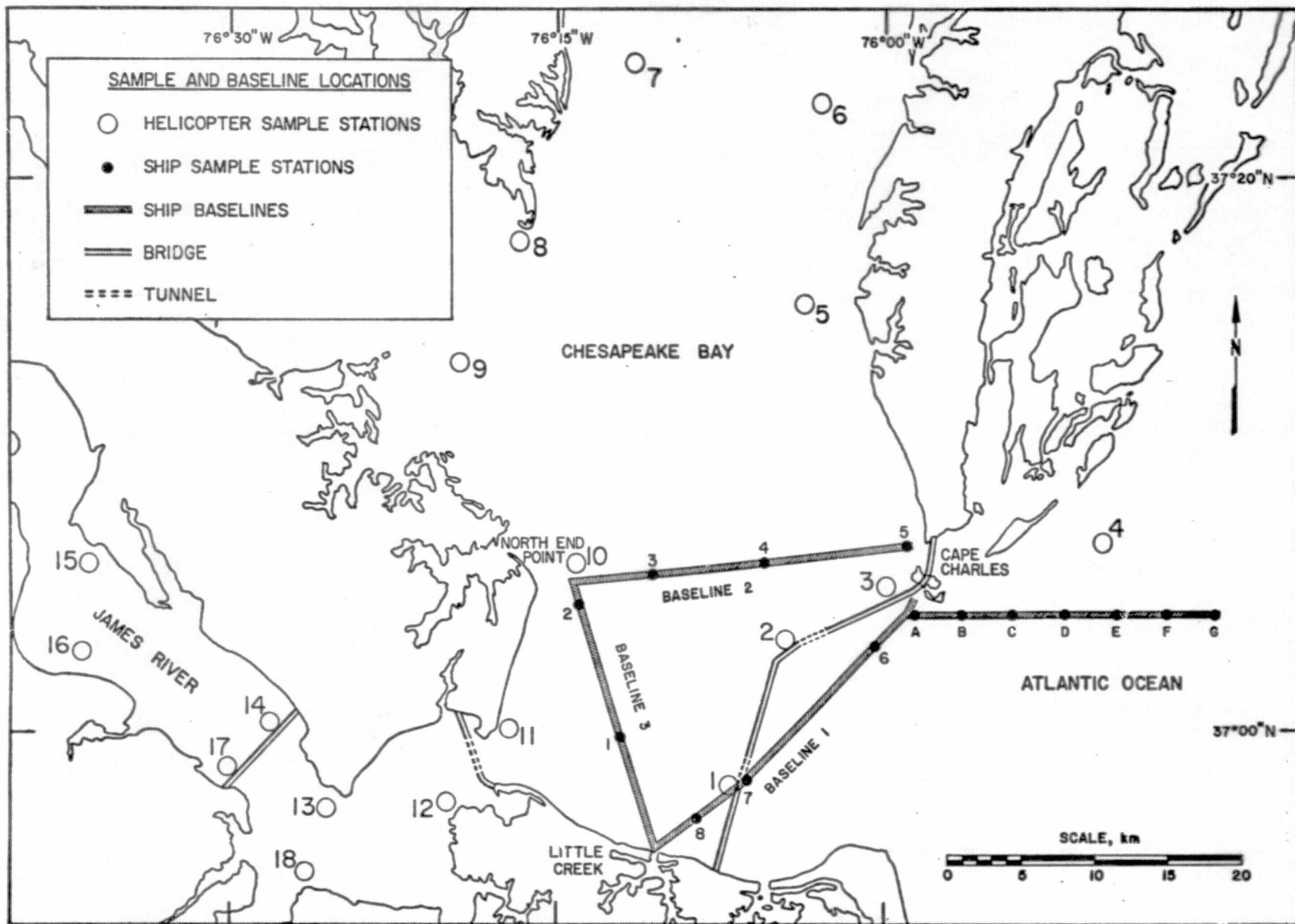

Figure 1. Location map of lower Chesapeake Bay-James River area.

the center of the station. Making one large sample per station out of four sub-samples was assumed to normalize local differences, which have been observed to vary by a factor of three or more for chlorophyll.

A simple snapshot from less than 10 feet altitude was always taken while facing north at the first station so as to have some record of visual wave-swell and cloud cover. Other snapshots were taken to show haze, changes in wave-swell conditions, slicks, smoke plumes, etc.

Normally only 100 to 200 cc of sample is consumed in the actual analysis. Only in winter months when the chlorophyll concentration is down is it necessary to use as much as 500 cc of sample (Open sea water may require samples another order of magnitude larger.).

The sample bottles were scrubbed with soap water and rinsed thoroughly with tap water the day before the flight.

Upon return to the landing pad, usually about one hour after the first sample was actually taken, the samples were preserved by adding approximately 2 ml of "stabilizer."

Formula for stabilizer: (100 ml)

0.4 grams sodium cacodylate

4 grams of disodium salt of EDTA-2H<sub>2</sub>O

80 ml of 50% solution of Glutaraldehyde

Dilute to 100 ml

Filter through 0.2  $\mu$ m filter in clean glassware. May be saved for about a month in refrigerator, but must be refiltered before use.

#### Chlorophyll Analysis

Upon return to the laboratory the chlorophyll analysis was usually begun immediately. If time requirements did not permit this, the samples were stored in the refrigerator (not frozen) until that evening. Under no circumstances were the samples more than seven or eight hours old before processed for chlorophyll content.

The chlorophyll analysis was the standard method as described by Strickland and Parsons (ref. 1) (see Appendix B).

The reader should note that chlorophyll analyses are only good estimates having precisions of  $\pm 10$  to  $30\%$ ; thus time is wasted if aliquots of materials used in the analysis are measured precisely instead of taken within  $\pm 5\%$ .

The chlorophyll samples were allowed to stand overnight in the acetone solution in the refrigerator and were always kept in the dark or in a dimly-lighted room. The analyses were completed within the following 24 to 48 hours.

The five chlorophyll extract-solution transmission readings were entered into a computer program for data reduction. The results of the chlorophyll analyses are tabulated in Appendix C.

#### Particle Count Analysis

Particle count analysis was accomplished 24 to 72 hours after collection of the sample. Only when the weekend closing of the counting facilities at NASA-Langley Research Center forced the longer delays was this done.

The system was kept scrupulously clean at all times.

A 10.0-ml aliquot of the sample, bottle shaken vigorously before withdrawing sample, was placed in a small (25-mm millipore,  $0.2 \mu\text{m}$ ) filter apparatus along with 1 ml of acridine orange stain solution which was then allowed to stand for one to two minutes before vacuum was applied.

Formula for acridine orange solution (50 ml) made fresh for each day of use:

0.03 g Acridine orange

1.5 g sodium chloride

Dilute to 50 ml and shake mixture to dissolve dye

Filter through  $0.2 \mu\text{m}$  filter

The dry filters were laid flat on several layers of paper towels for at least one hour and all dust kept away, and were then transferred to a slide mount (millipore XX 1007615) which had an area coated with millipore non-drying immersion oil (XX 7000 050) to clear the disc. The mount was then covered with a clean 22-mm coverslip and then counted on the NASA-Langley  $\pi\text{MC}$  Particle Measurement Computer System Facility using the 100X objective lens. Care was taken not to get bubbles under the cover slip.

Five fields were selected on each filter and counted with the following seven settings: Total (0), 0.5, 1.0, 2.0, 4.0, 8.0 and 16.0  $\mu$  diameters.

These 35 numbers were also entered into a computer program for data reduction. Particle counts are tabulated in Appendix D.

### Turbidity Analysis

Turbidity was measured from the R/V LINWOOD HOLTON with a keel-mounted, continuous-recording transmissometer system adapted specifically for this study. The system consists of a modified Bendix/Marine Advisors C-2 transmissometer probe with a bracket for keel mounting and a modified Moseley model 80A-2 strip-chart recorder.

The transmissometer probe gives a measure of light transmittance in water. For a fixed beam path length, the degree of light attenuation, or turbidity, is generally expressed as the attenuation coefficient  $\alpha$ , where

$$\alpha = -\frac{1}{(\text{beam path-length})} \ln (\text{transmittance})$$

for a homogenous medium. The beam path-length was reduced from the standard 1 m to 0.430 m to make it operable in the relatively turbid water of Chesapeake Bay. The optical construction of the probe is such that only the light source and no ambient light is sensed at the receiving photocell. The light is filtered to a band-pass of about 50 nm centered at 525 nm.

The probe was mounted to the keel of the R/V LINWOOD HOLTON with a specially fabricated bracket that attached to the keel. Two holes in the keel and two eye-plates were the only hull modification required. Due to the massive construction of the probe and mounting bracket it was possible to operate the instrument without distortion at maximum vessel speed of 18 km/hr and at wave heights to 2.5 m. Optimum running speed was 11-14 km/hr, and at this speed the probe measured the transmittance at a depth of 1.2 m below the water surface. The probe configuration and mount is described in detail by Berg et al. (ref. 2) (see Appendix E).

Transmittance was recorded on a modified Moseley model 80A-2 strip-chart recorder with an automatic balancing circuit that replaced the conventional

manual readout of the probe. The modifications and corresponding circuitry for this system have been reported in detail by Bryant (ref. 3). A crystal-controlled two pulse per second generator produced a chart speed of 1.270 cm/min within 0.1%. The chart drive is therefore independent of powerline frequency, which on a small boat is not necessarily well regulated.

Transmittance profiles generated over the baselines during a satellite overpass were accurately time-referenced and located by known, constant vessel speed and navigational checks. The three resulting transmittance-distance profiles produced over the triangular course (Figure 1) were then digitized and computer-plotted as attenuation coefficient  $\alpha$  vs. distance. These profiles are displayed in Appendix F. All profiles are presented in a sequential counter-clockwise sense: Baseline 1, Little Creek to Cape Charles; Baseline 2, Cape Charles to North End Point; Baseline 3, North End Point to Little Creek (Figure 1).

#### Bathymetry Analysis

Bathymetric profiles along the baselines were obtained on two occasions. The profiles were made with an Edo model 578 Survey Depth Recorder. Accuracy of this instrument was better than  $\pm 0.3$  m during normal operating conditions. Since depth changes over the period of overpass can be assumed relatively minor, and the baseline course was closely adhered to, there was no need to obtain a profile with each overpass. The two profiles were taken seven months apart, and are essentially similar. Minor variations can be accounted for by navigational error and possible small changes in depth. Reduced, digitized, and computer-plotted versions of the profiles are presented in Appendix G. The location and orientation of these profiles is the same as for the  $\alpha$ -profiles described above.

#### Suspended Sediment

Surface-water samples collected from the R/V LINWOOD HOLTON during baseline traverses were analyzed for suspended sediment concentration by filtration. For each sample, 7 - 9 liters of water were passed through a preweighed 0.45  $\mu$ m Millipore filter. The filters were dried at 100 °C and weighted, and suspended sediment concentration expressed in mg/liter. Suspended sediment concentrations are tabulated in Appendix H.

## Salinity and Temperature

Salinity and temperature determinations were also made on surface-water samples collected from the R/V LINWOOD HOLTON during baseline traverses. Salinity was measured with an Industrial Instruments model RS5-3 *in situ* inductive Salinometer. Temperature was determined with a bucket thermometer. Salinity and temperature values are tabulated in Appendix H.



## DATA ANALYSIS

The sampling stations and baselines are shown in Figure 2. All of the stations were not visited each day, however. The ship usually traversed the three baselines around the lower Bay; two trips (July 25 and October 23) were made up the James River and one (July 7) into the Atlantic Ocean.

Table 1 lists the LANDSAT-1 overpass dates, the number of samples collected, and the availability of MSS tapes. Three of the LANDSAT-1 overpasses (December 4, January 9, and July 26) were on days following the lower Bay overpasses. Only the James River was visible on these days. Helicopter and ship samples were collected on 13 days each with 8 days common to both. Fortunately, both helicopter and ship samples were taken on 3 of the 4 days when cloud-free MSS tapes were available. For a total of 22 LANDSAT-1 overpasses of the lower Bay, then, useful MSS tapes were available for only 4 occasions, a less than 1 in 5 probability for obtaining good data.

### Correlation Between Water Parameters

The correlation between the parameters monitored during the analysis of the water samples has been calculated for the helicopter and ship data on a daily basis and for the total. The correlation coefficients are given in Tables 2 and 3, respectively, for the total data. The helicopter data in Table 2 has been blocked off into four groups to help illustrate several interesting observations.

The correlation of total chlorophyll with chlorophylls A, B, C, and carotenoids, columns 9 to 12 in the last row, is excellent (0.87 - 1.00). Thus, chlorophyll A, B, or C could be measured and the total chlorophyll data derived. The correlation of particles with the chlorophyll data, columns 2 to 8 and rows 9 to 13, is low (0.02 - 0.22). This indicates that plankton is not a significant contribution to the particle data and is not associated with any specific particle size environment.

The correlation of total particles with each particle size range (0.51 to 0.94) suggests that total particles are only fairly representative of any given size range. The average particle size histogram for each day

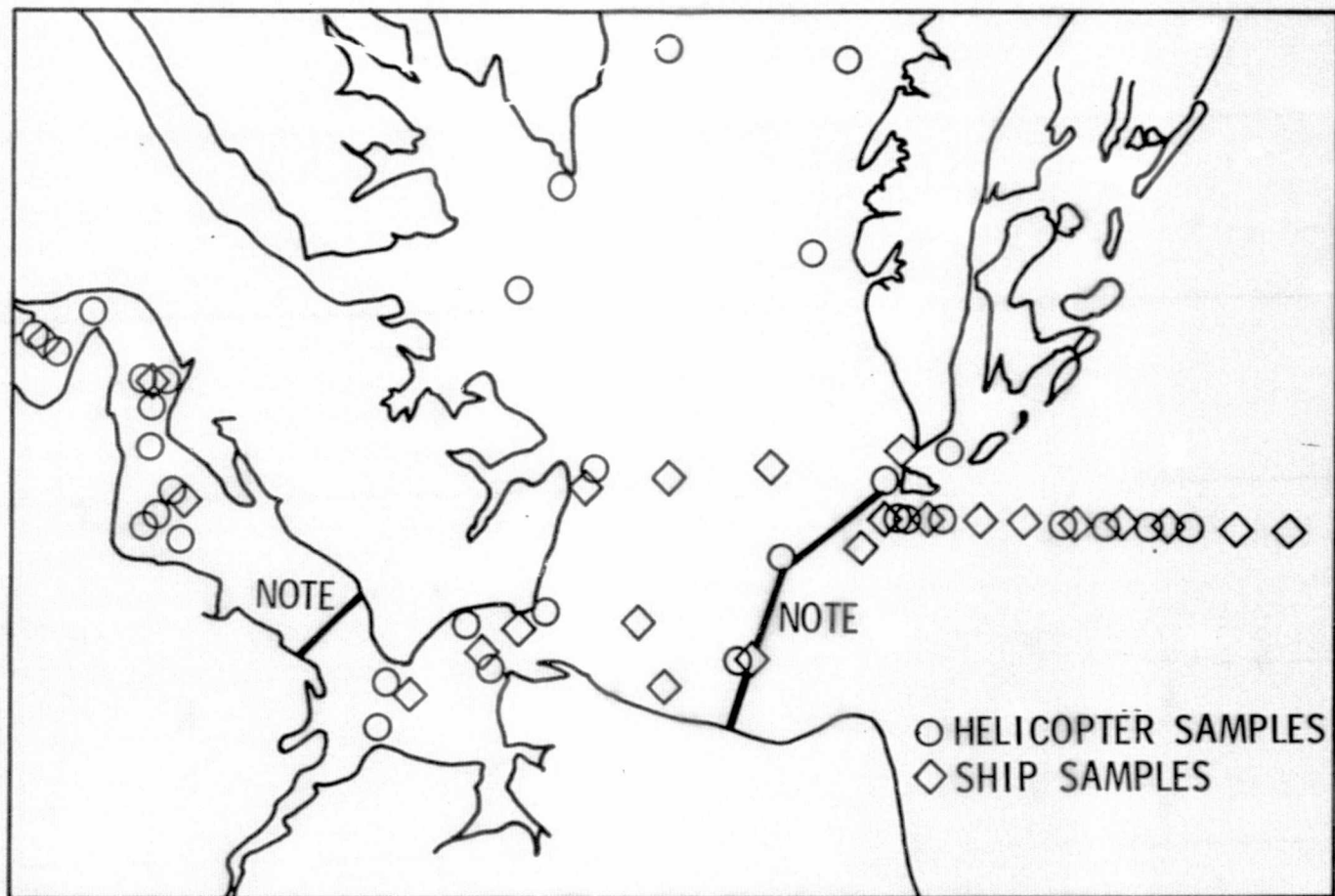

NOTE: HELICOPTER SAMPLES WERE TAKEN ALONG THE JAMES RIVER BRIDGE AND THE CHESAPEAKE BAY BRIDGE-TUNNEL ON 26 JANUARY 1973 AND 13 FEBRUARY 1973

Figure 2. Location of sampling stations.

Table 1. Record of Sample Collection and Analysis of MSS Tapes.

<u>LANDSAT-1 OVERPASS DATE</u>	<u>HELICOPTER SAMPLES</u>	<u>SHIP SAMPLES</u>	<u>LANDSAT-1 TAPES ANALYZED</u>
OCT. 10, 1972	18		X
DEC. 3, 1972	18	8	
DEC. 4, 1972	14		
JAN. 9, 1973	6		
JAN. 26, 1973	33	7	X
FEB. 13, 1973	33	6	X
MAR. 3, 1973		7	
APR. 8, 1973		6	
MAY 14, 1973		2	
JUNE 1, 1973		7	
JUNE 19, 1973		6	
JULY 7, 1973	7	9	X (HAZY)
JULY 25, 1973	20	6	
JULY 26, 1973	5		
AUG. 30, 1973	13		X (FOG)
SEPT. 17, 1973	18	7	
OCT. 5, 1973	18	7	X
OCT. 23, 1973	15	6	
<u>18 DAYS</u>	<u>218</u>	<u>84</u>	<u>6</u>

Table 2. Correlation Coefficients for Helicopter Sample Variables.

NO. VARIABLE	1	2	3	4	5	6	7	8	9	10	11	12	13
1 DEPTH	1.00												
2 PART 0-5	-.13	1.00											
3 PART .5-1	-.01	.73	1.00										
4 PART 1-2	-.04	.65	.87	1.00									
5 PART 2-4	-.14	.66	.51	.69	1.00								
6 PART 4-8	-.12	.57	.36	.53	.92	1.00							
7 PART 8-16	-.14	.31	.10	.26	.75	.81	1.00						
8 PART TOT	-.09	.77	.86	.94	.85	.74	.51	1.00					
9 CHLOR A	.30	.10	.16	.14	.06	.06	.11	.14	1.00				
10 CHLOR B	.23	.10	.21	.20	.03	.02	.04	.15	.91	1.00			
11 CHLOR C	.20	.10	.22	.21	.05	.03	.04	.17	.88	.98	1.00		
12 CAROT	.21	.09	.17	.15	.02	.03	.05	.13	.83	.86	.86	1.00	
13 CHLOR TOT	.22	.10	.21	.21	.05	.03	.05	.17	.91	.99	1.00	.87	1.00

Table 3. Correlation Coefficients for Ship Sample Variables.

NO.	VARIABLE	1	2	3	4	5	6
1	TIME	1.00					
2	DEPTH	-.04	1.00				
3	TEMP	-.19	.03	1.00			
4	SALINITY	-.32	.05	.37	1.00		
5	ATTEN COEF	.23	.07	-.41	-.69	1.00	
6	SEDIMENT	.12	-.03	.03	-.39	.67	1.00

peaked in the 1- to 2- $\mu$ m size range (column 4) 50% of the time, and was equally divided between the next lower and higher size ranges the other days.

The last point to be made about Table 2 is the correlation of depth with each parameter. The water depth was taken from the National Ocean Survey nautical charts, corrected for tide (the maximum tidal variation is about 3 feet at the stations farthest up the James River). Although the correlation coefficients are low, there is a negative correlation of depth with particle count and a positive correlation of depth with chlorophyll; that is, when depth increases chlorophyll increases and particle count decreases. On a daily basis, the correlations with total particles varied from -0.03 to -0.61 and with total chlorophyll from -0.46 to 0.38. The positive correlations with total chlorophyll generally occurred on days when the chlorophyll level was high.

The correlation between variables for the ship data revealed two interesting relations. The data indicates a negligible correlation (-0.03) between sediment and depth, consistent with the correlation between total particles and depth. However, the sediment versus depth correlation for ship data varied from -0.77 to 0.73 on a daily basis. One possible reason for the large variation is that the ship stations were all located in relatively deep water (average depth 30 feet) whereas the depth at the helicopter stations varied from 2 feet to 73 feet. Also, there were usually only six to seven ship stations which may not have been adequate for meaningful results.

The attenuation coefficient had a correlation of 0.67 with sediment for a combined total of 13 days. These data are shown plotted in Figure 3. The linear regression curves for each day's data, with the exception of one (December 3), were nearly parallel. With the removal of that one day's data from the total, the correlation improved to 0.80. Thus the attenuation coefficient was useful for checking the sediment data for anomalous values.

Since the ship and helicopter did not occupy the same stations, it was not possible to establish a one-to-one relationship between sediment and particle count. An average sediment and particle distribution was determined for each day, however, and a comparison was made for the 8 days

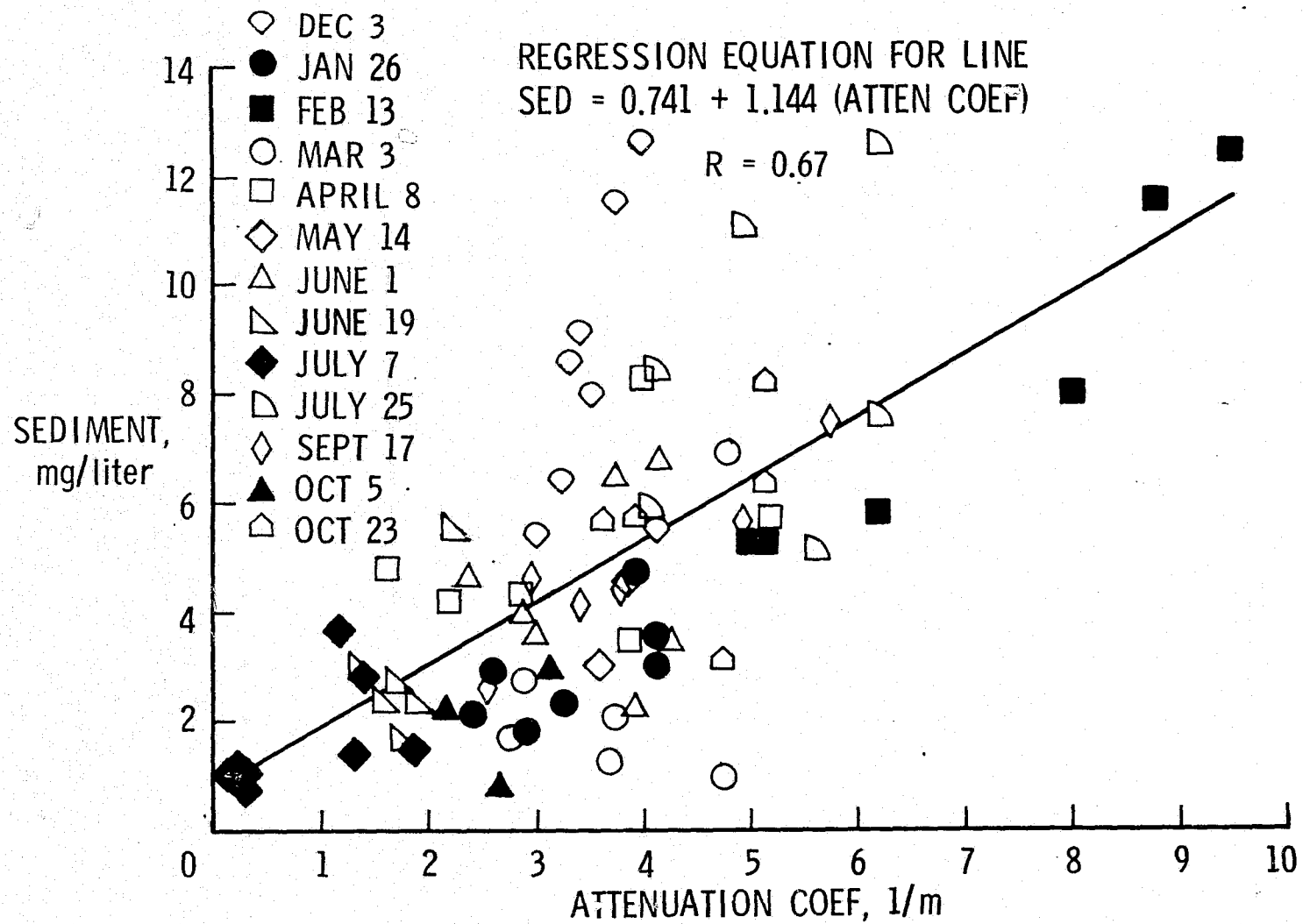

Figure 3. Linear regression plot for sediment versus attenuation coefficient including data for all days.

when both sets of data were available. The correlation between average sediment and average total particles was 0.31. When total particles were converted to total volume, by assuming spherical shapes with a mean diameter equal to the mid value of each particle size range, the correlation improved to 0.40. The most meaningful relationship was the correlation of sediment with the average histogram mean (0.73). These data are plotted in Figure 4. It can be seen that an increase in sediment indicates an increase in the average particle size, not simply an increase in particle number. A more direct relation between sediment and particles will be established later by using the radiance values at each station.

#### Correlation of MSS Data With Water Parameters

Radiance values associated with each water sample were extracted from the computer compatible tapes by locating the station coordinates on a CTT generated gray level map. An average of 48 pixels (six scan lines by eight pixels per line) centered around the coordinate were taken to minimize the effect of banding, caused by the unequal response of the six detectors for each band.

In the combined analysis of several days data, the radiance values were multiplied by  $1/\cos \theta$  to correct for varying solar illumination. In addition, a dark level correction was investigated by subtracting the radiance of the darkest object in the scene, taken to be the first zero below the central peak in the gray level histogram. This made no improvement in any of the combined data, however, so the results are not included.

Correlation coefficients were determined for each water parameter with the four MSS bands and with all algebraic combinations of any two bands. Several combinations improved the correlations on certain days but made little to no improvement when all days were considered. As seen below, bands (5-6) slightly improved the correlations with total particles.

#### Particles

The correlation coefficients for total particles with each MSS band are given in Table 4. The linear regression equations are shown for bands (5-6), which gave a more consistent correlation on the 4 days when cloud-free data was available. The data for the October 10 overpass was collected on October 9; thus



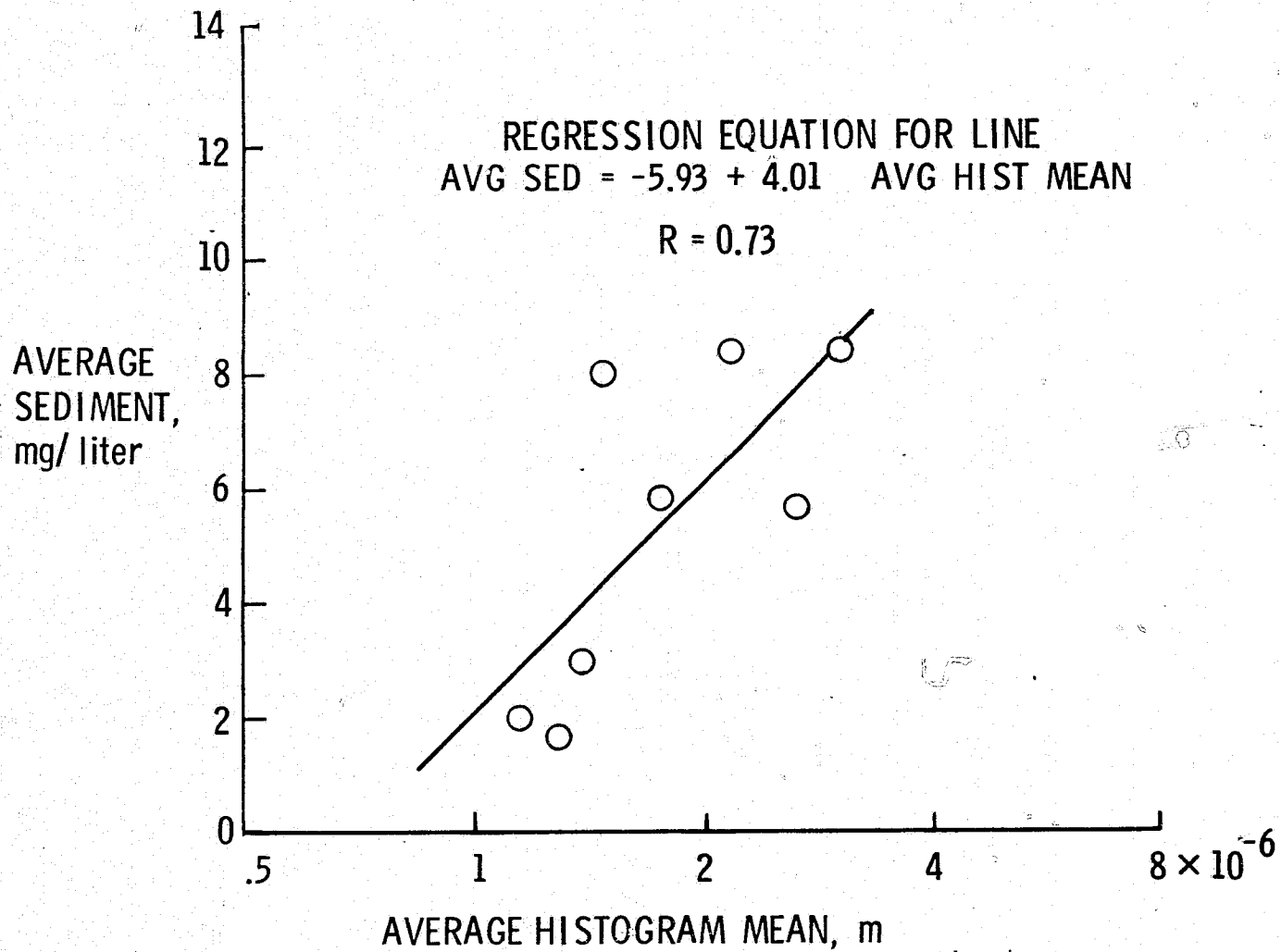

Figure 4. Linear regression plot of average sediment versus average histogram mean.

Table 4. Correlation Coefficients and Linear Regression Equations for Total Particles.

---

BAND	OCT. 10	JAN. 26	FEB. 13	JULY 7	AUG. 30	OCT. 5	TOTAL
4	.53	.73	.88	.50	.45	.31	.15
5	.56	.74	.88	.57	.52	.38	.34
6	.53	.68	.85	.61	.42	.13	.43
7	.51	.13	.77	.57	.37	-.04	.14
5-6	.58	.74	.87	.49	.55	.58	.22

---

LINEAR REGRESSION EQUATIONS

OCT. 10 BANDS (5-6) =  $0.119 + 1.03 \times 10^{-10}$  (TOTAL PARTICLES)

JAN. 26 BANDS (5-6) =  $0.068 + 3.54 \times 10^{-10}$  (TOTAL PARTICLES)

FEB. 13 BANDS (5-6) =  $0.138 + 8.14 \times 10^{-10}$  (TOTAL PARTICLES)

OCT. 5 BANDS (5-6) =  $0.113 + 1.02 \times 10^{-10}$  (TOTAL PARTICLES)

---

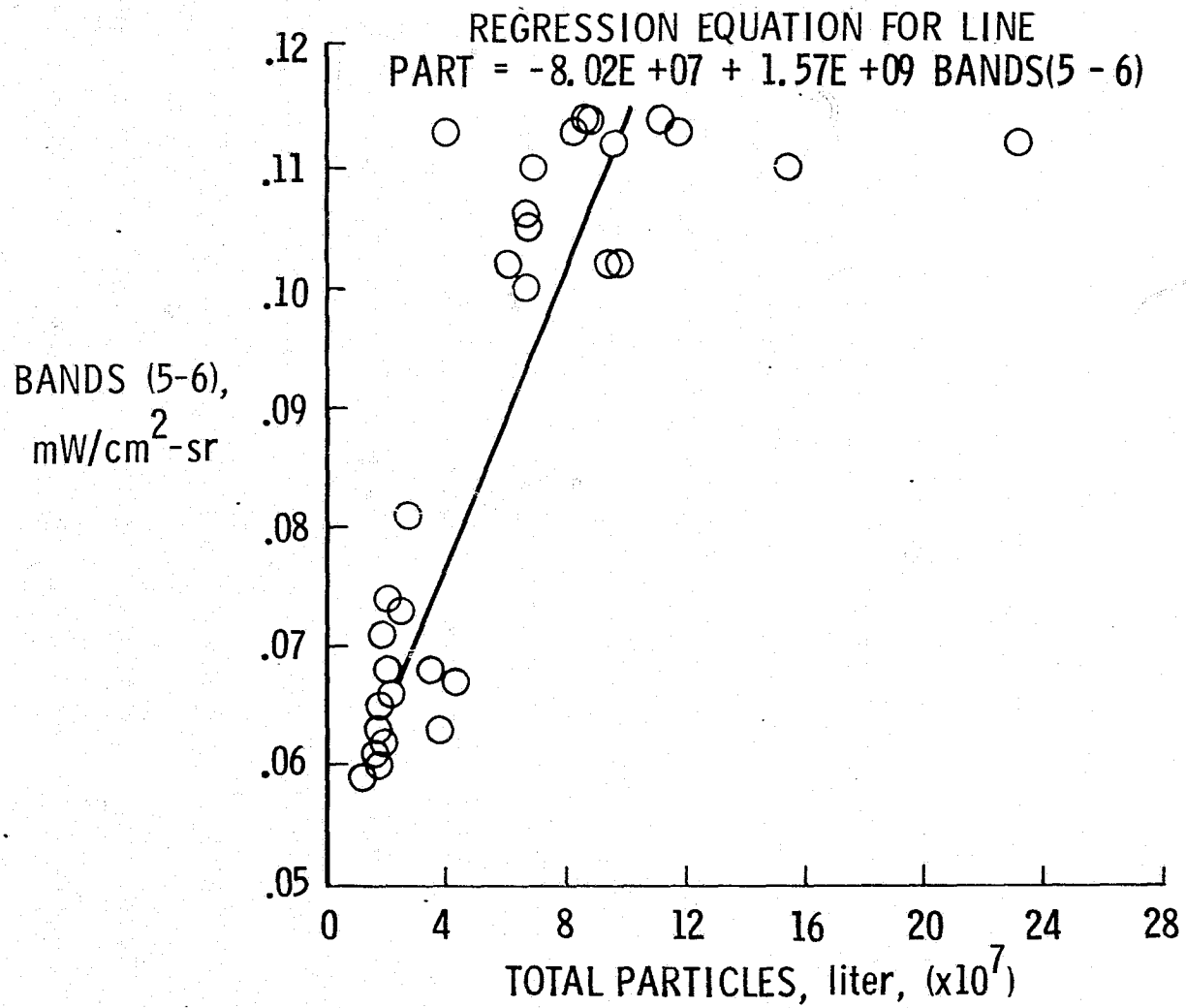

Figure 5. Bands (5-6) radiance versus total particles for Jan. 26.

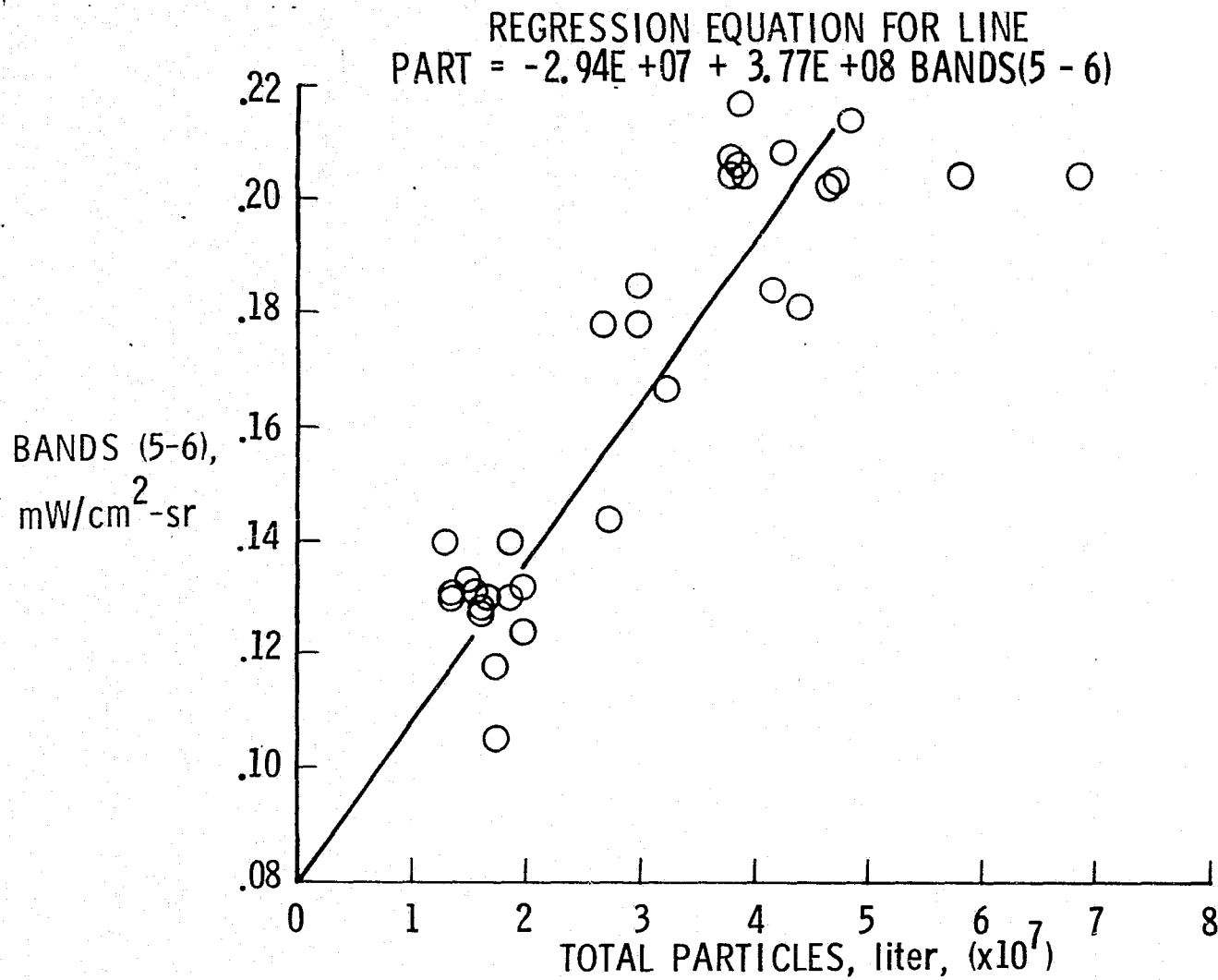

Figure 6. Bands (5-6) radiance versus total particles for Feb. 13.

Table 5. Correlation Coefficients and Linear Regression Equations for Total Chlorophyll.

---

BAND	OCT. 10	JAN. 26	FEB. 13	JULY 7	AUG. 30	OCT. 5	TOTAL
4	.37	.85	-.70	.80	.02	-.06	.12
5	.36	.84	-.68	.72	-.26	-.04	.24
6	.41	.76	-.61	.65	-.17	-.08	.33
7	.45	.10	-.61	.67	-.08	-.02	.16

---

LINEAR REGRESSION EQUATIONS

OCT. 10 BAND 4 =  $0.469 + 3.01 \times 10^{-4}$  (CHLOROPHYLL)

JAN. 26 BAND 4 =  $0.295 + 4.53 \times 10^{-3}$  (CHLOROPHYLL)

FEB. 13 BAND 4 =  $0.494 - 3.57 \times 10^{-3}$  (CHLOROPHYLL)

OCT. 5 BAND 4 =  $0.511 - 1.49 \times 10^{-3}$  (CHLOROPHYLL)

---

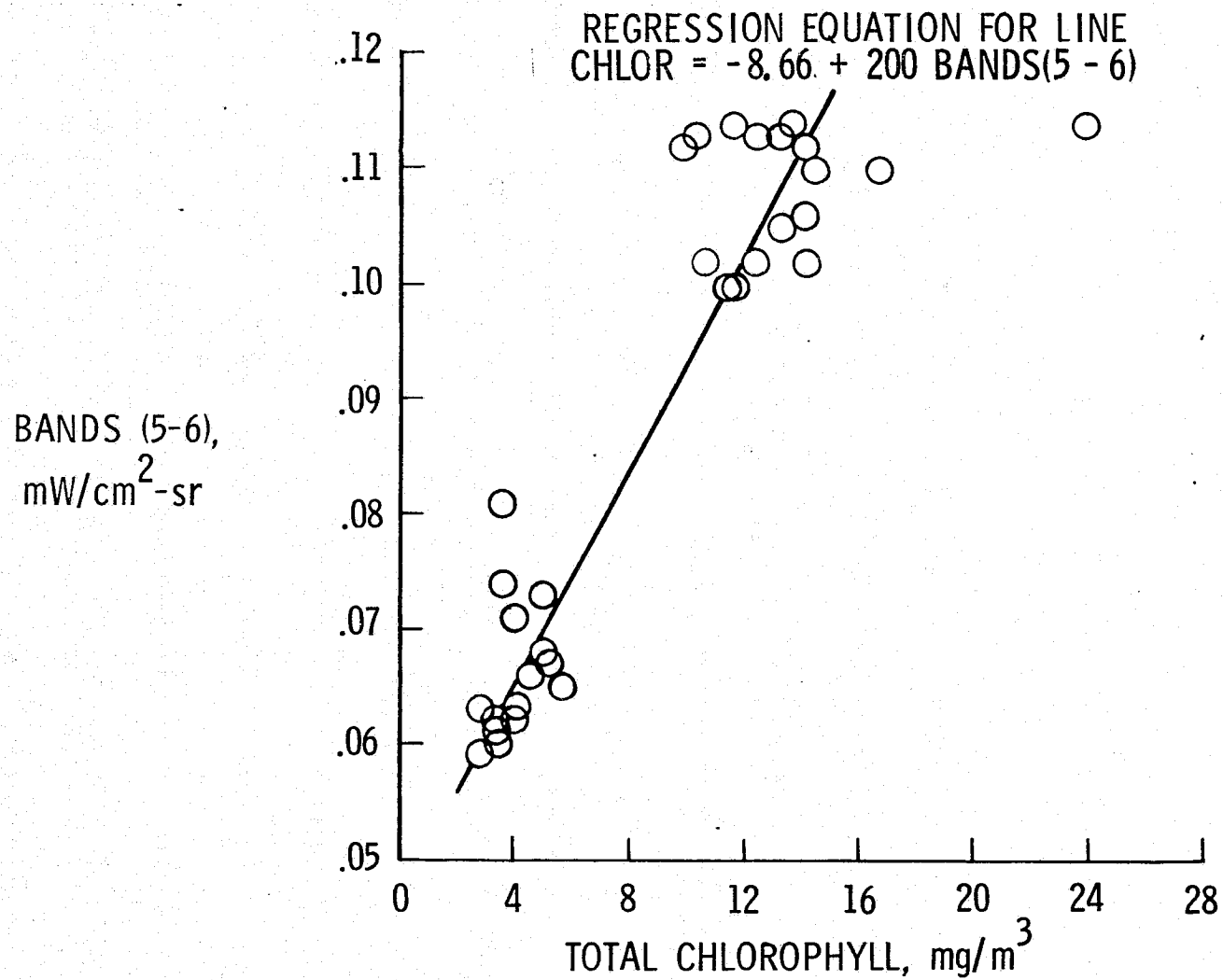

Figure 7. Bands (5-6) radiance versus total chlorophyll for Jan. 26.

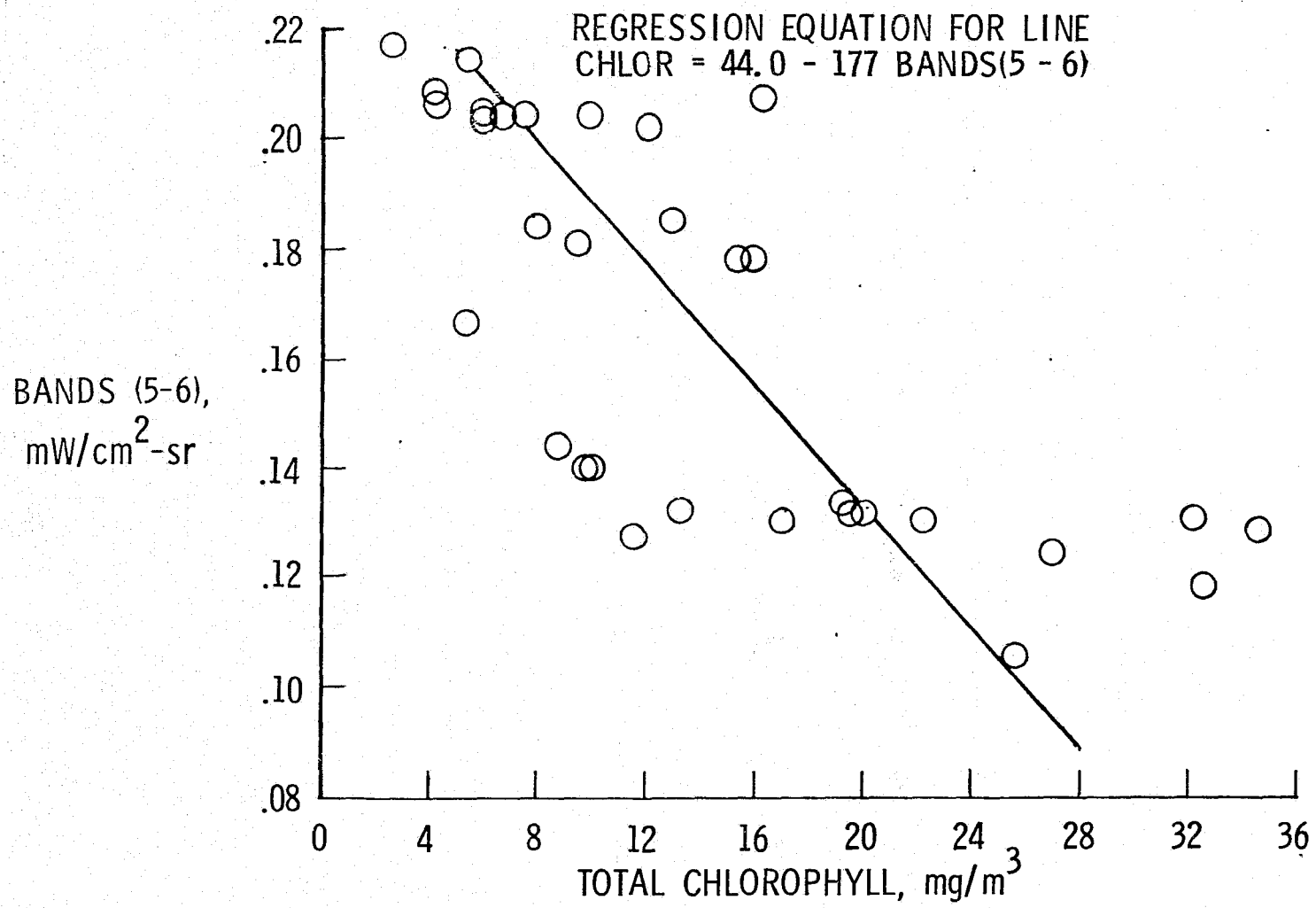

Figure 8. Bands (5-6) radiance versus total chlorophyll for Feb. 13.

24-hour-old data may account for the low correlation. The October 5 image showed clouds to the west of the sampling area, probably causing an increase in radiance values and degrading the correlations. This point will be discussed more fully in the sediment analysis.

Total particles are shown plotted against bands (5-6) radiance for January 26 and February 13 in Figures 5 and 6, respectively. Particle counts generally tend to show considerable scatter, even when the samples are taken from the same station. Under these conditions, it is felt that the correlations with radiance values are very good (.74 and .87).

Yost (ref. 4) obtained good correlations of particles with radiance for a photographic additive color combination of bands 5 and 6. In this analysis bands (5x6) also gave satisfactory results ( $R=.70$  and .87).

In Table 4 it is seen that the slope of the regression equations (the second constant in each equation) varies by a factor greater than 2 when only the January 26 and February 13 data are considered, and by a factor of 8 for all 4 days. Thus, it will be necessary to calibrate the particle-radiance relationship on a daily basis. Combining the data in the total analysis results in a lower correlation, as expected.

### Chlorophyll

The correlation coefficients for total chlorophyll are given in Table 5. The correlation for January 26 with band 4 is .85. However, this feature is not consistent. It is noticed that the signs of the coefficients for February 13 are reversed from those of January 26. The reasons for this becomes apparent when radiances are plotted against chlorophyll. Bands (5-6) radiance is plotted against chlorophyll for January 26 and February 13 in Figures 7 and 8, respectively. Bands (5-6) are used in order to make a comparison with the particle data ( $R=.86$  and  $-.71$  for the 2 days). For January 26 the cluster of high chlorophyll data points represents stations across the James River, whereas the cluster of low chlorophyll data represents stations across the entrance to the Bay. On February 13 the James had the lowest chlorophyll values, yet the radiance values continued to be high. From this it appears that chlorophyll is not significantly influencing the radiance values; particles are certainly more dominant.



This issue can be investigated further by examining the radiance errors at each station. Figure 9 shows the radiance error for the linear regression equation between particles and bands (5-6) plotted as a function of chlorophyll a concentrations for January 26. Chlorophyll a is used in this instance to stress the fact that the level is below "bloom" conditions (chlorophyll a  $\geq$  50  $\mu\text{g}/\ell$ ); total chlorophyll would have given similar results. The radiance error is the difference between the observed and predicted radiance values at each station. A regression line for the errors versus chlorophyll data is given for January 26, February 13, and October 5, along with their respective correlations. All three of the lines are nearly parallel to the zero error axis and the correlations are low. It is concluded that any error introduced into the particle-radiance relationship, by chlorophyll, is essentially random.

Figure 10 is a similar plot where the radiance error for the band 4 regression equation for chlorophyll is given as a function of total particles for January 26, February 13, and October 5. In this case all regression lines show a positive slope and the correlations are higher. When total particles increase there is an increasing positive error introduced into the chlorophyll radiance relationship. Thus, it is apparent that particles (not chlorophyll) are primarily related to the radiance variations.

It is not surprising that low chlorophyll values are not appreciably influencing the data since it is well known that the MSS bands are not optimized for the detection of chlorophyll. Bressette (ref. 5) and Strong (ref. 6) have found, however, that the near-IR bands respond to very high chlorophyll levels, such as found in algal blooms. This was confirmed for the ERTS September 23, 1975 image of the Potomac River. Band 6 showed an increase in radiance in the bloomed areas while band 5 radiance decreased. The reason is that chlorophyll is highly absorptive in the visible wavelengths and thus interferes with the normal back scattering of light by particulates.

#### Sediment

The correlation between sediment and the MSS bands is presented in Table 6 for the 3 days when sediment data was taken. The correlations with band 5 are the most consistent (0.78 to 0.93). Even when the data are combined, the correlation is reasonably good (0.72).

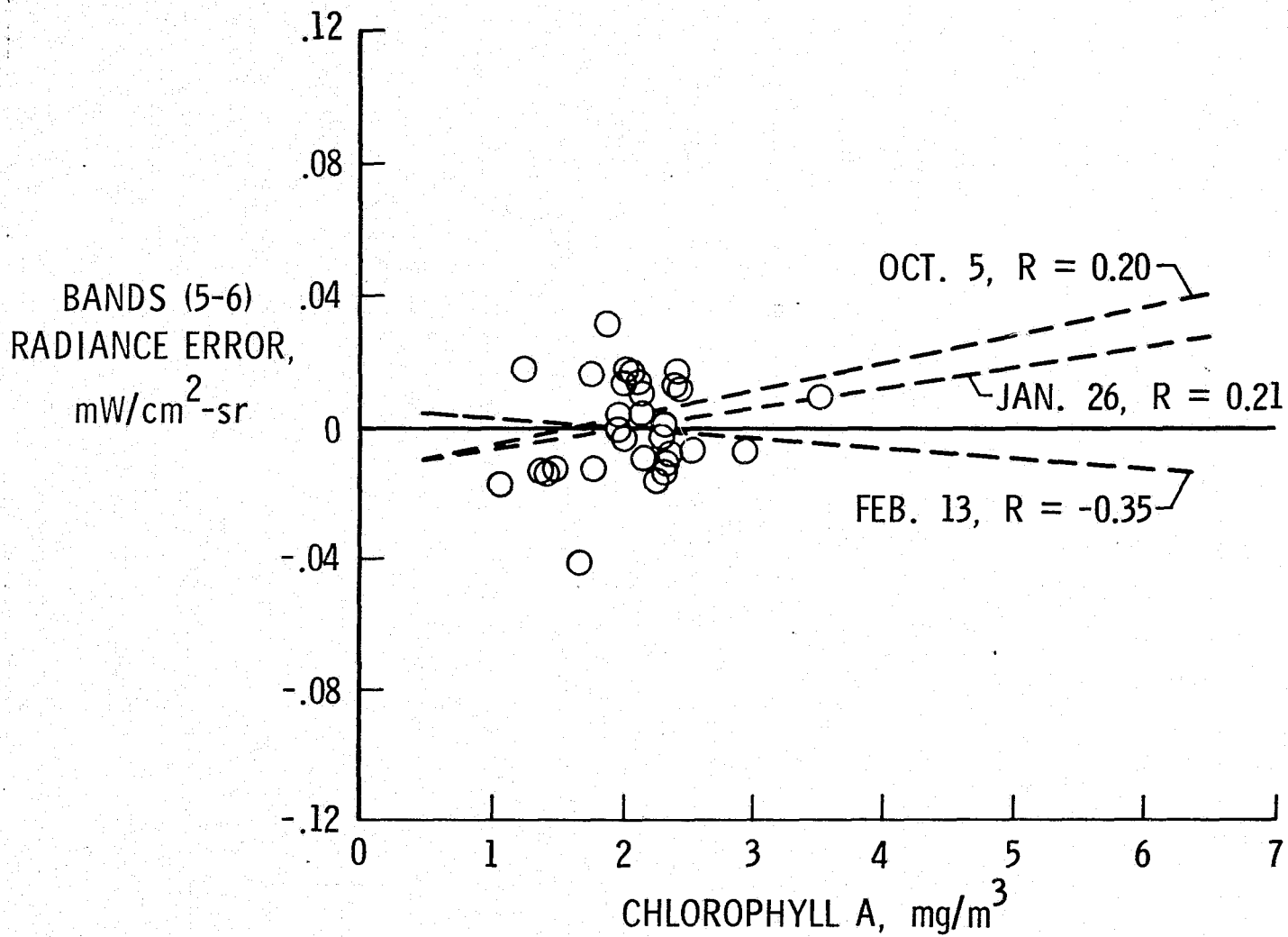

Figure 9. Linear regression plots for bands (5-6) particle radiance error versus chlorophyll for given dates including data for Jan. 26.

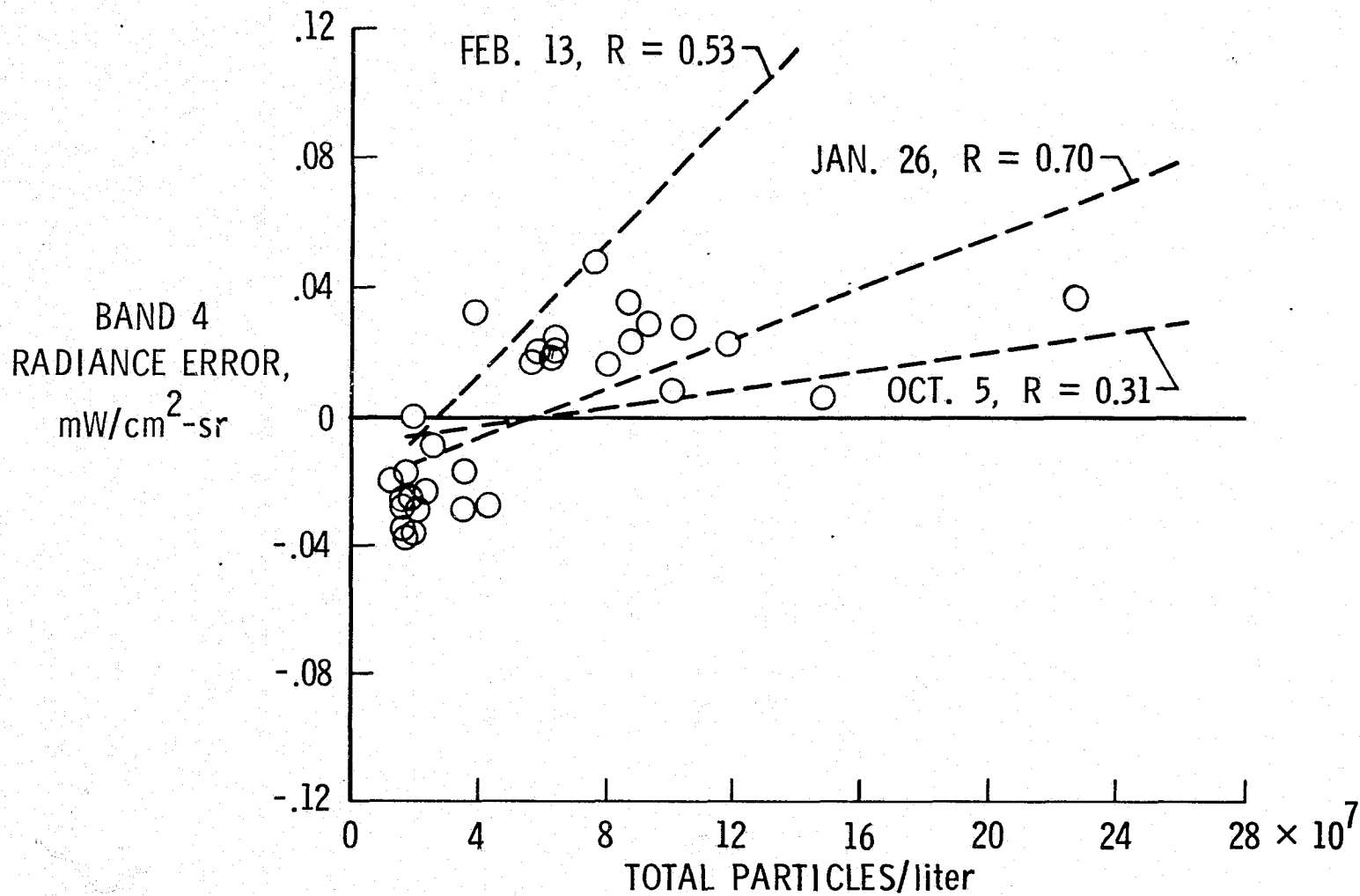

Figure 10. Linear regression plots for band 4 chlorophyll radiance error versus total particles for given dates including data for Jan. 26.

Table 6. Correlation Coefficients and Linear Regression Equations for Sediment.

BAND	JAN 26	FEB 13	OCT 5	TOTAL
4	.93	.59	.85	.80
5	.86	.93	.78	.72
6	.79	.75	.45	-.08
7	-.11	.47	.85	.22

JAN 26	BAND 5 = 0.080 + 0.011 (SEDIMENT)
FEB 13	BAND 5 = 0.142 + 0.0035 (SEDIMENT)
OCT 5	BAND 5 = 0.202 + 0.0013 (SEDIMENT)

It is possible to improve the total correlation, however, by making an adjustment in the radiance levels for October 5. Table 7 gives the gray scale histogram maximum for each MSS band for all 6 days. Only the water pixels in the lower Bay area are included (band 7 gray scale  $\leq 3$ ) and the gray levels have been corrected for Sun angle by multiplying by  $1/\cos \theta$ . Since many of the water pixels have been eliminated, such as those displaying clouds or fog, the gray scale maximums for August 30 are not too different from October 5. It is noticed that the gray scale maximums for band 5 on January 26, February 13, and October 5 are 15, 19, and 21, respectively. The differences between January 26 and February 13 are presumably due to the average sediment difference (highest on February 13). However, the sediment level on October 5 was similar to January 26, thus the gray levels should be about the same. Reducing the average radiance level on October 5 by six gray values increases the total correlation between sediment and band 5 to 0.92. The increased radiance on October 5 is probably due to the atmosphere, since there are a large number of cirrus clouds to the northwest. It is possible that sea state could be influencing the data also.

A plot of the combined sediment versus band 5 is given in Figure 11. In the correlation analysis of the water parameters it was found that the attenuation coefficient  $\alpha$  was representative of sediment in the lower Bay area. For the 3 days with LANDSAT-1 data the correlation between these two parameters was .97. A plot of the attenuation coefficient versus band 5 is shown in Figure 12. Because of the excellent correlation between these parameters, the terms sediment and  $\alpha$  are often used interchangeably.

#### Variables Influencing Sediment

Radiance values offer another means for comparing sediment and particles. Since a linear relationship was established for bands (5-6) and particles it is possible to predict total particles at the ship stations and, likewise with band 5, predict sediment at the helicopter stations. The linear relations between sediment and particles, as determined in this manner, are shown plotted in Figure 13 for the 3 days when helicopter, ship, and radiance data were available. It is seen that an increase in average sediment between days does not necessarily indicate an increase in total particles. On February 13, when the average sediment was high, the average particle count was actually

Table 7. Corrected Gray Scale Histogram Maximums for Lower Chesapeake Bay Water Pixels.

BAND	OCT. 10	JAN. 26	FEB. 13	JULY 7	AUG. 30	OCT. 5
4	33	35	39	31	36	37
5	17	15	19	16	20	21
6	8	19	8	9	13	11
7	2	1	2	2	3	2

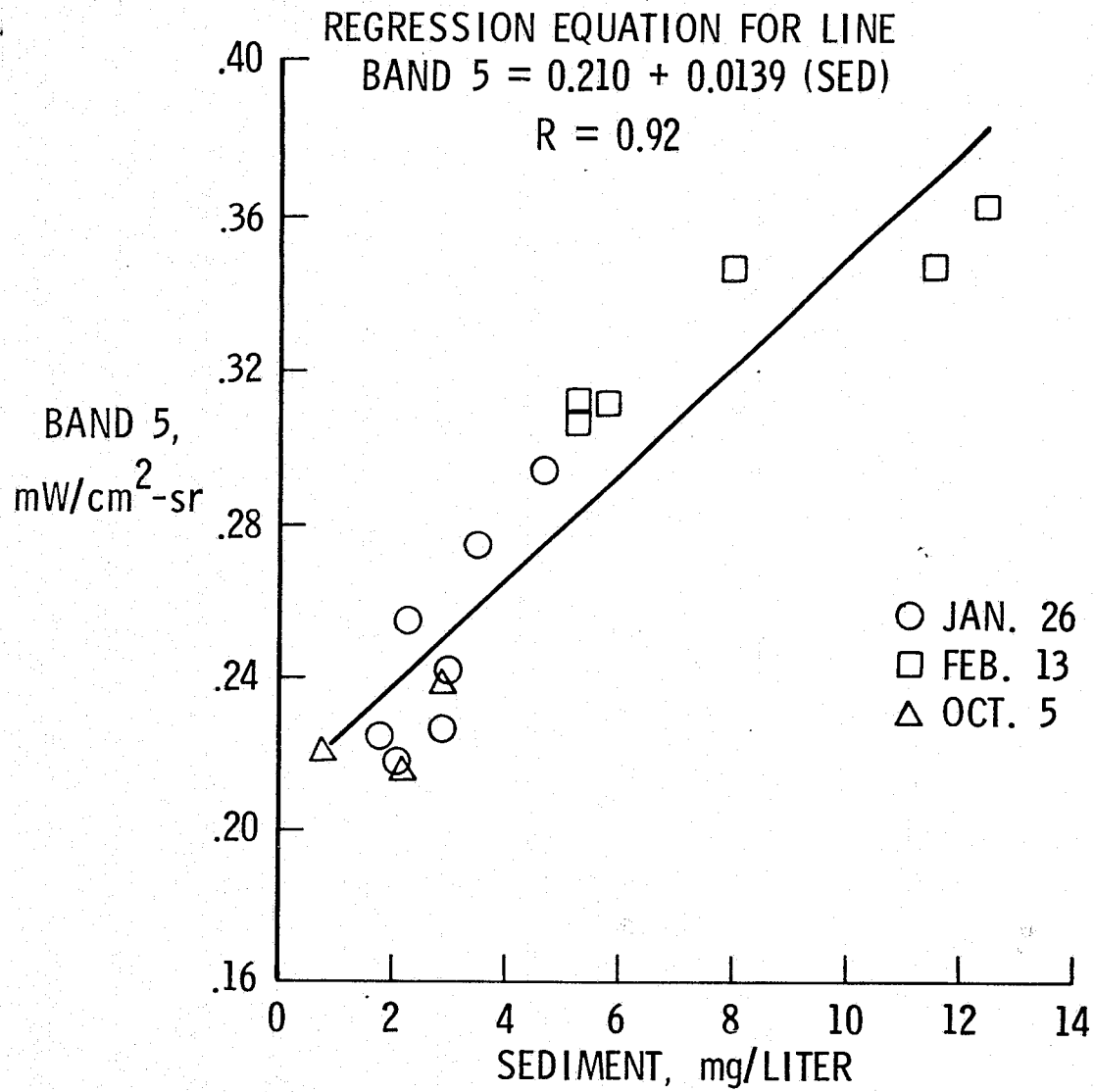

Figure 11. Band 5 radiance versus sediment for given dates.

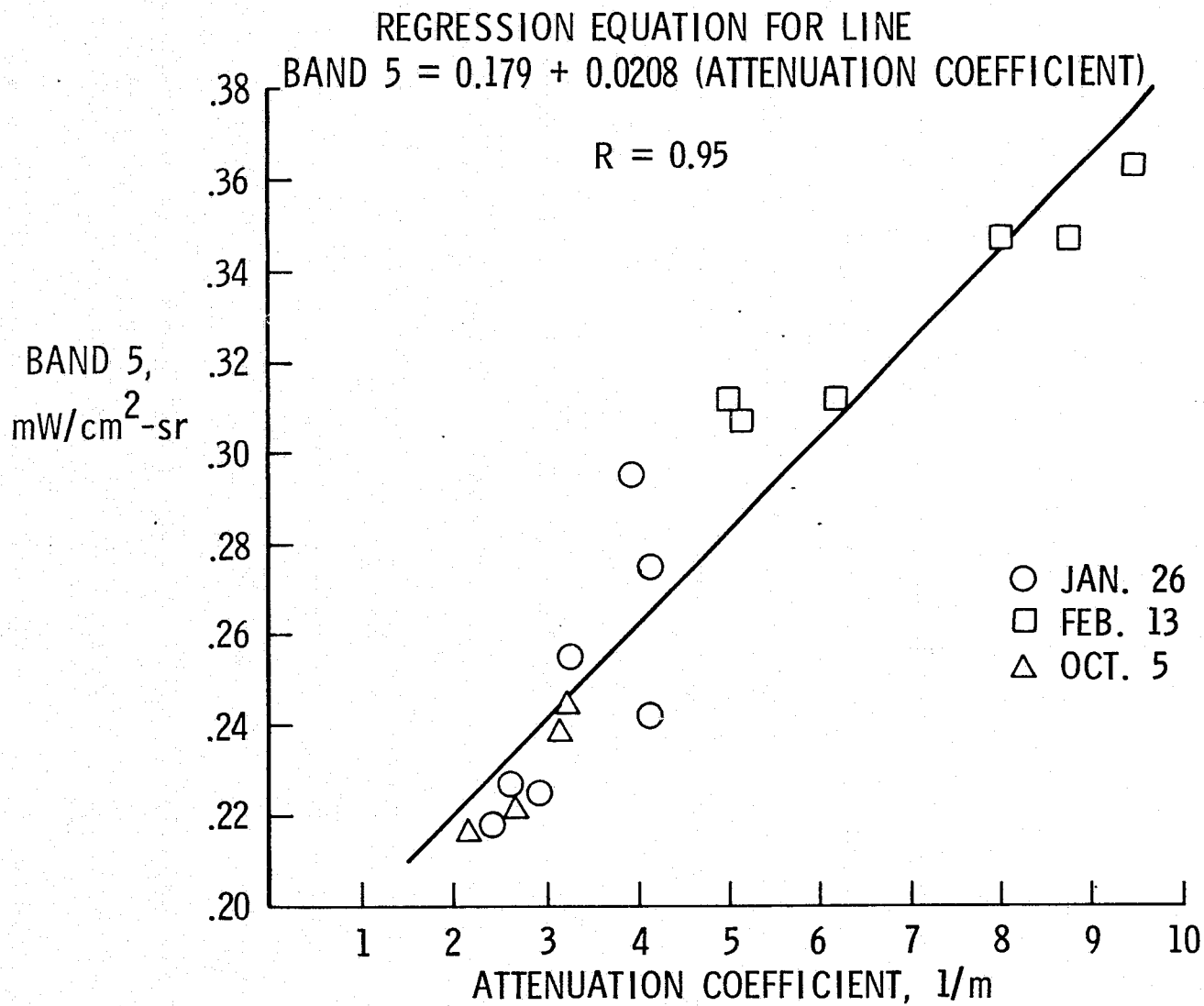

Figure 12. Band 5 radiance versus attenuation coefficient for given dates.



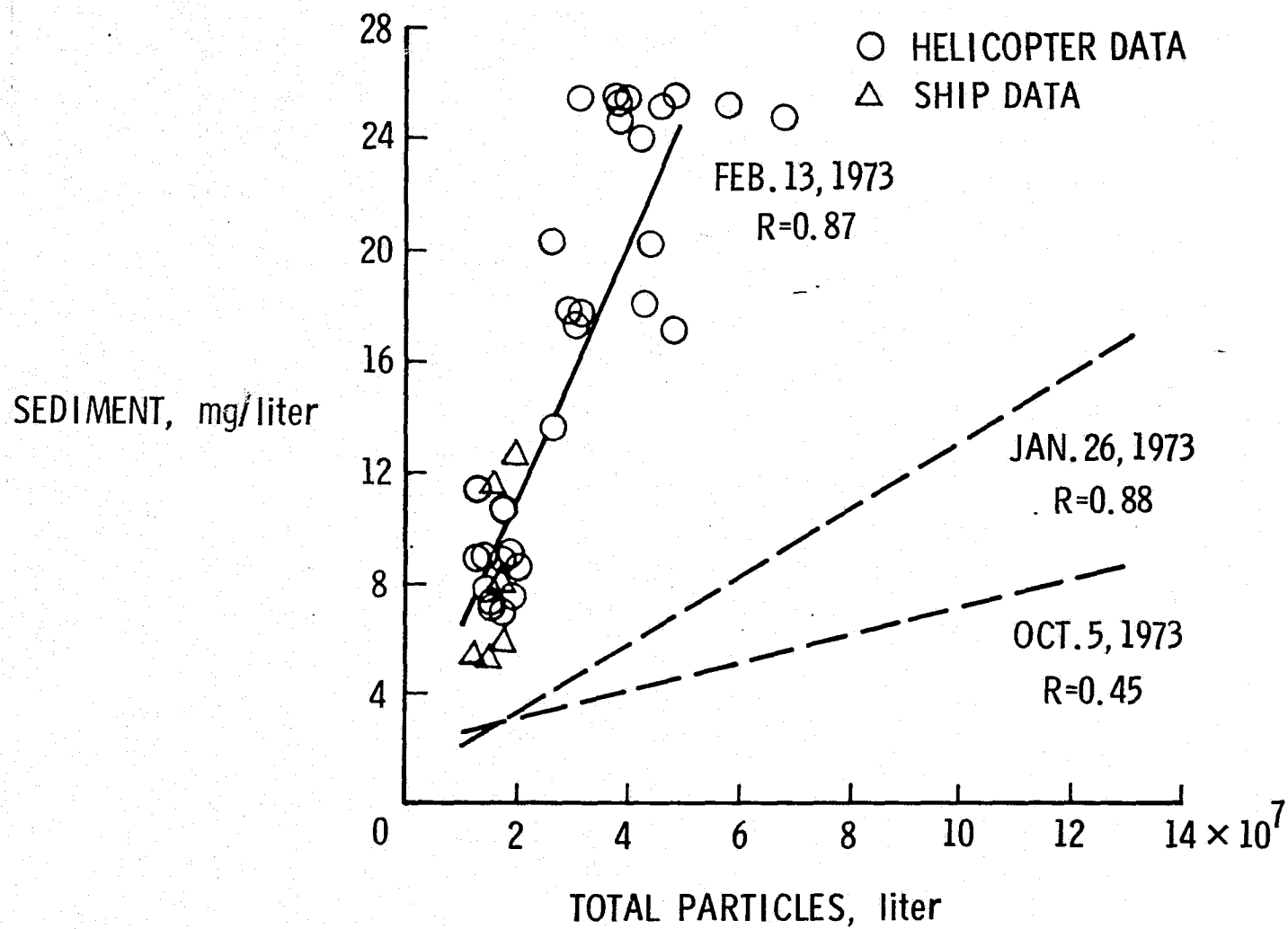

Figure 13. Linear regression plots for sediment versus particles for given dates including data for Feb. 13.

lower than on October 5, which had a low average sediment. The increase in particle size was clearly the more important parameter on February 13.

From this analysis it seems that the back-scattered radiance is more sensitive to total suspended weight (or volume) than it is to the number of particles. Both are important, of course, but for this set of data particle size was certainly dominant. This is consistent with the scattering coefficient data given by Hodara (ref. 7).

Another important relationship can be established between the average daily sediment and wind velocity. Figure 14 shows the average sediment as a function of the 3-day average resultant wind velocity. The wind records were supplied by NOAA's Environmental Data Service for the Norfolk weather station. The regression line suggests that wind is an important parameter influencing the surface sediment.

The excellent correlation between sediment and band 5 prompted the construction of a sediment contour map of the lower Bay area. LANDSAT-1 passed over the area near low tide on each of the 3 days for which sediment and MSS data were available. The contour plot is shown for January 26 in Figure 15. The tide is past low tide and is beginning to flood. One interesting feature, not generally recognized before, is the displacement of the James River "plume" toward the southern shore (toward Little Creek). The usefulness of such contour maps will certainly increase when they can be made at a more regular interval.

#### Analysis of Baseline Data

The continuous  $\alpha$  recordings along each of the baselines is shown plotted in Appendix A. Baseline data for January 26, February 13, and October 5 have been cross correlated with the radiance profiles abstracted from the MSS tapes. In general, the correlations have been influenced by several undesirable factors: (1) the banding in the LANDSAT-1 MSS imagery reduced the quality of the data; (2) the time of the baseline traverse was up to 6 hours away from the LANDSAT-1 overpass; (3) the  $\alpha$  profiles contained much more detail than the corresponding radiance profiles; and (4) the ship did not have precise navigation equipment and was unable to stay on the baseline and maintain a constant speed.

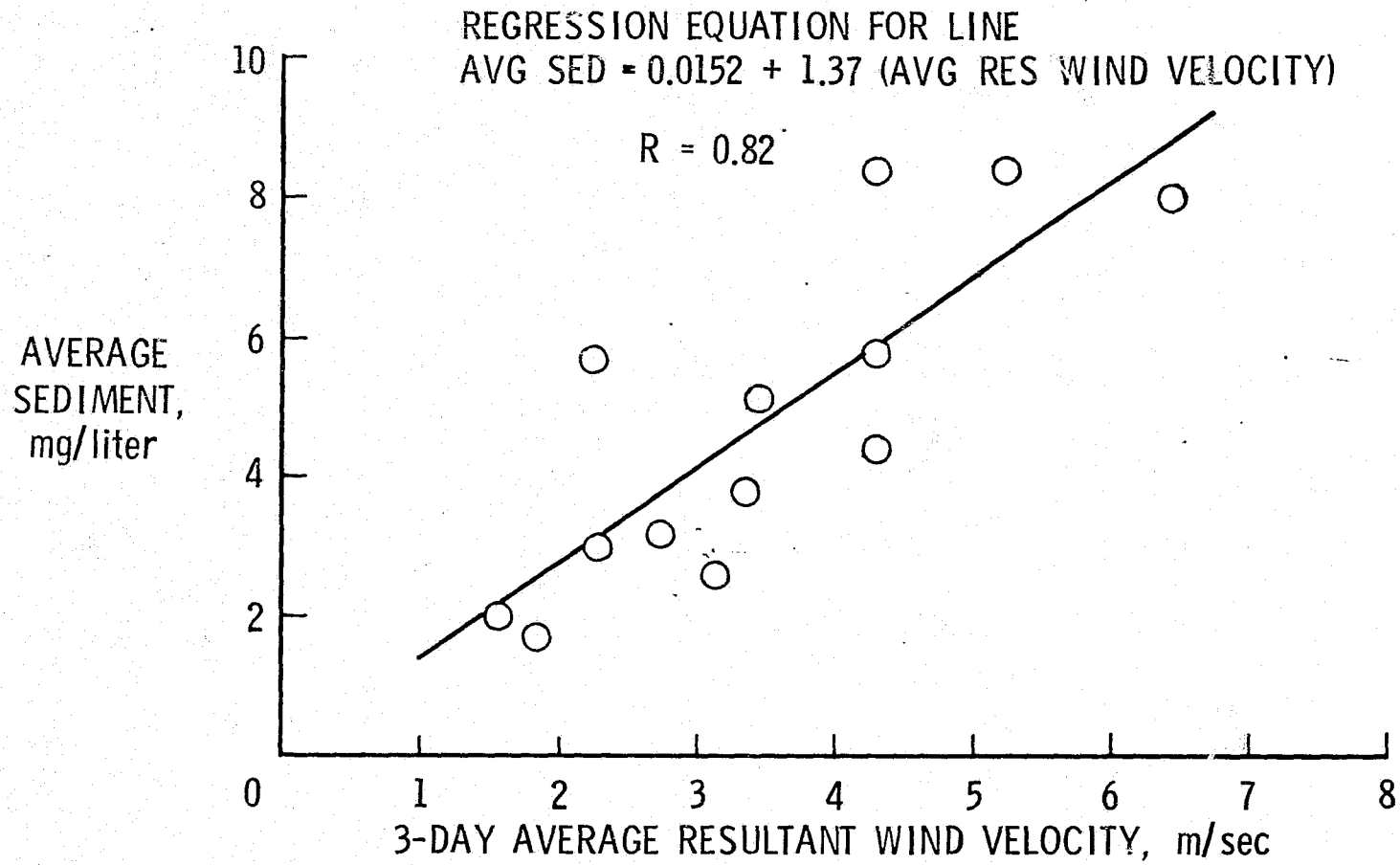

Figure 14. Linear regression plot for average sediment versus 3-day average resultant wind velocity.

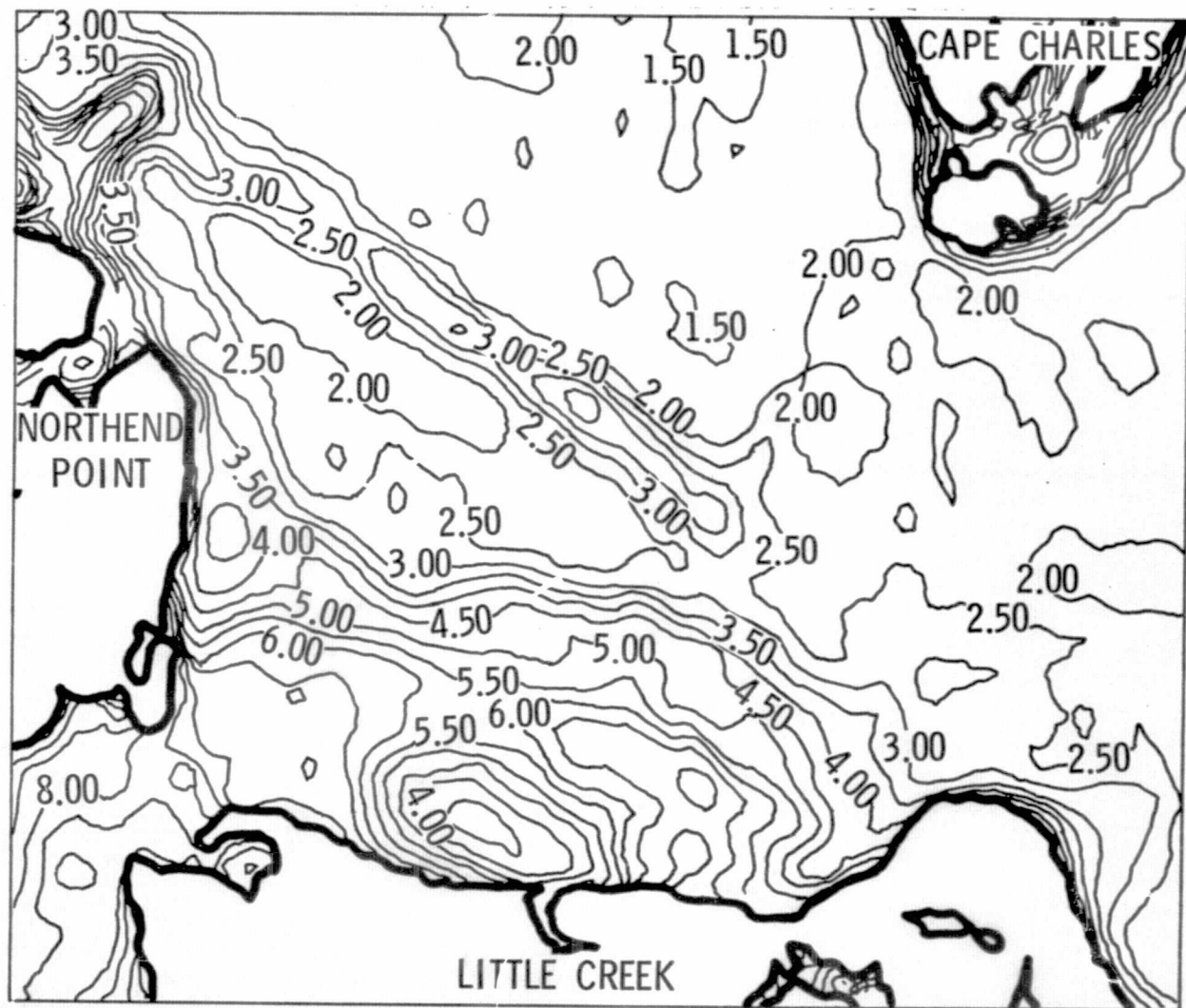

Figure 15. Sediment contour map of the lower Chesapeake Bay area for Jan. 26. Contour interval is 0.5 mg/liter.

An example of the  $\alpha$ -radiance profiles is given in Figure 16 where the data are shown for baseline 1 on January 26. The difference in time between the LANDSAT-1 overpass and the mean time of the baseline was only 34 minutes, and the  $\alpha$  data were not unusually anomalous. Thus, with good radiance data, one would expect a high correlation. This is clearly the case, since the correlation with band 4 is 0.86. The transmission-radiance profiles for the three baselines on January 26 and February 13 can be found in reference 8.

The cross correlations for each baseline on the 3 days are plotted in Figure 17 as a function of the time difference between the LANDSAT-1 overpass and the mean baseline time. Band 4 was used because the transmissometer bandpass filter peaked at about 525 nanometers, which is within band 4. Correlations with band 5 behaved in a similar manner, however. It is clear from Figure 17 that there is a degradation in correlation when time difference increases. What remains to be seen is whether the tidal influence on the data can be accounted for, in the presence of seasonal and other temporal influences.

Figure 18 displays the relation of the mean baseline time to the tidal cycles for the baseline traverses. The tidal position was taken as the ratio of the time before or after high or low tide at Sewells Point, to the time between high and low tide, on the given day. The tidal times of the LANDSAT-1 overpasses are also indicated. Note that all three overpasses were near low tide.

Since baseline 3 had the best coverage with respect to tide, it was selected for a three-dimensional display. In Figure 19 the baseline data has been arranged according to tidal position, with time progressing from top to bottom. The baseline data have been normalized (average baseline alpha equals one) and June 19, December 21, and October 5 have been omitted for clarity. Sediment, or  $\alpha$ , is highest on the Little Creek end throughout most of the tidal cycle. There is a definite anomaly that begins to appear at Little Creek near high tide, reaches its maximum contract at ebb tide, and then disappears at flood tide. If features such as this are actually tide-dependent, it should be possible to select an  $\alpha$  transect closer in time, in the tidal cycle, to each LANDSAT-1 overpass and thereby improve the correlations between radiance and  $\alpha$ . For instance, the January 26 baseline 1 data are closer in tidal time to the October 5 overpass than are the October 5 baseline 1 data.

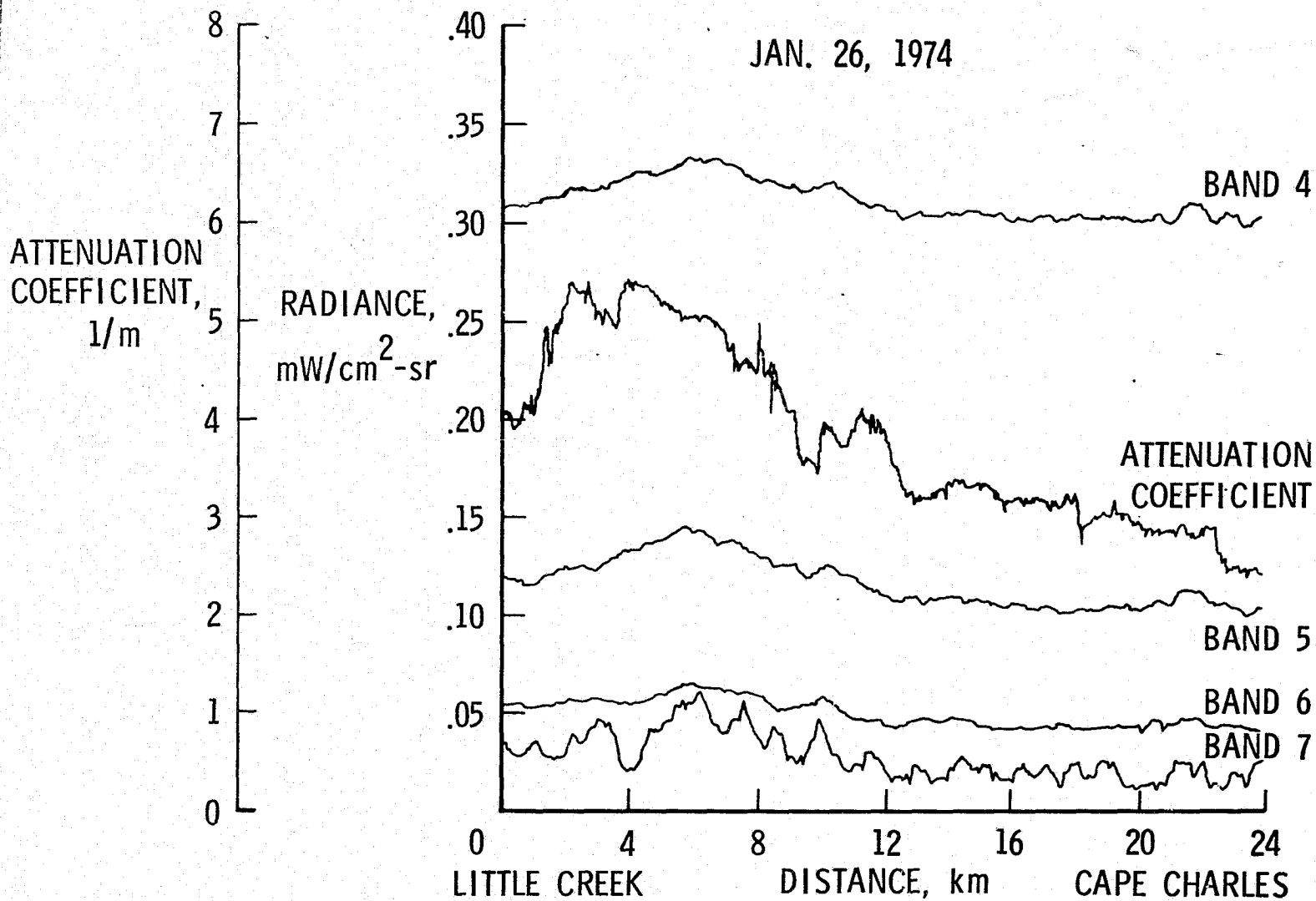

Figure 16. Plots of radiances (4 bands) and attenuation coefficient measured along baseline 1 for Jan. 26.

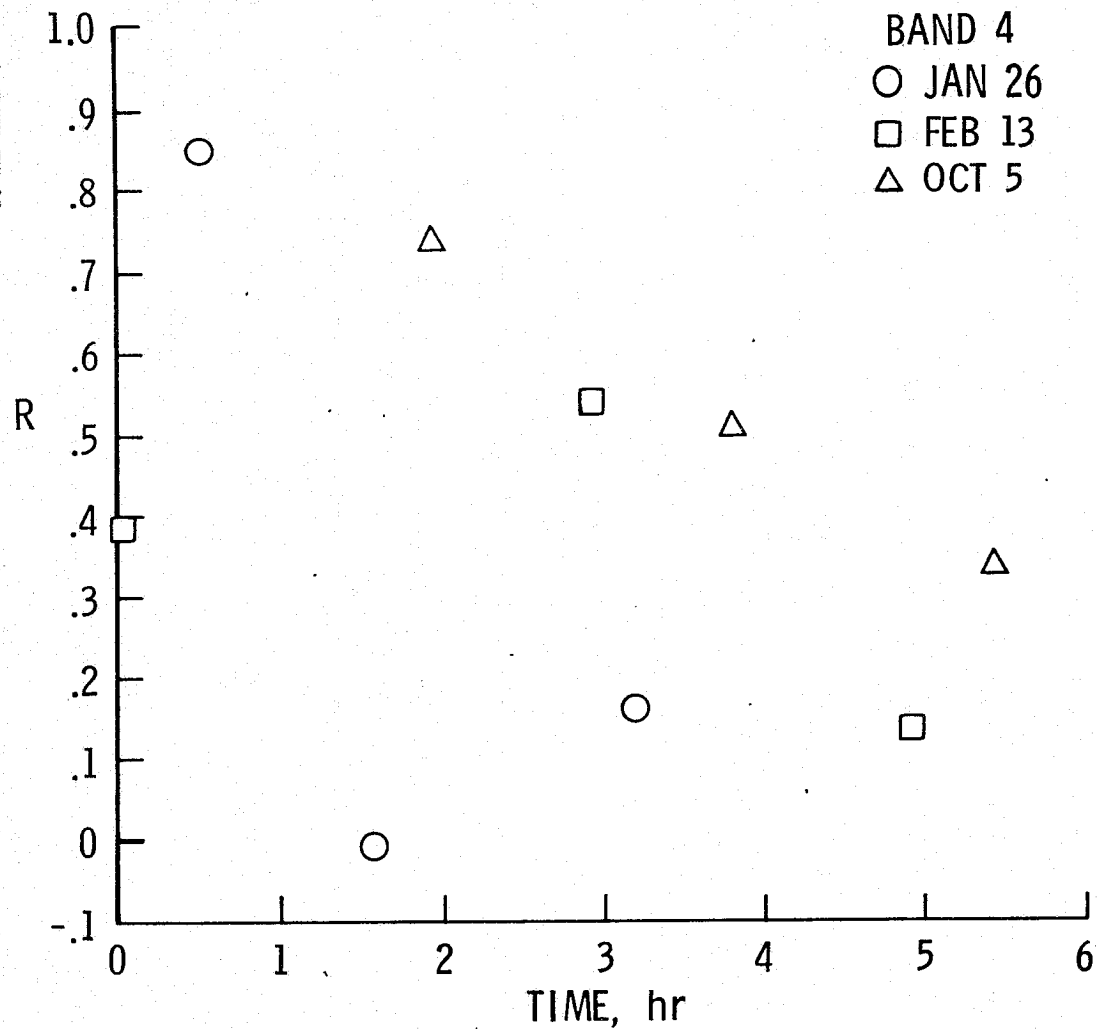

Figure 17. Correlation coefficients between band 4 radiance and attenuation coefficient plotted as a function of time between LANDSAT-1 overpass and mean ship transect time.

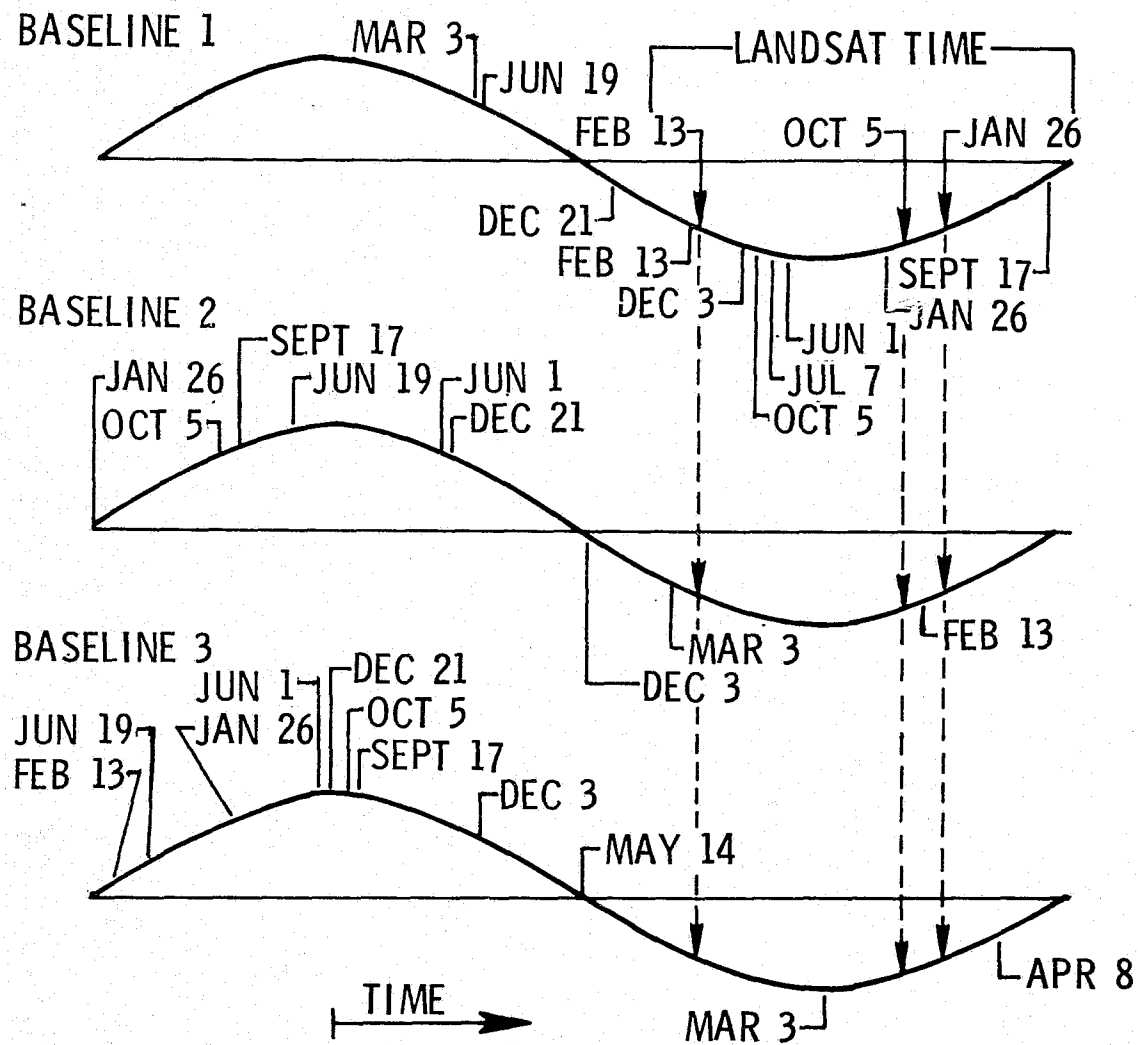

Figure 18. Position of tide during ship transects along three baselines at mean baseline time for given days and at time of LANDSAT-1 overpass on 8 days.



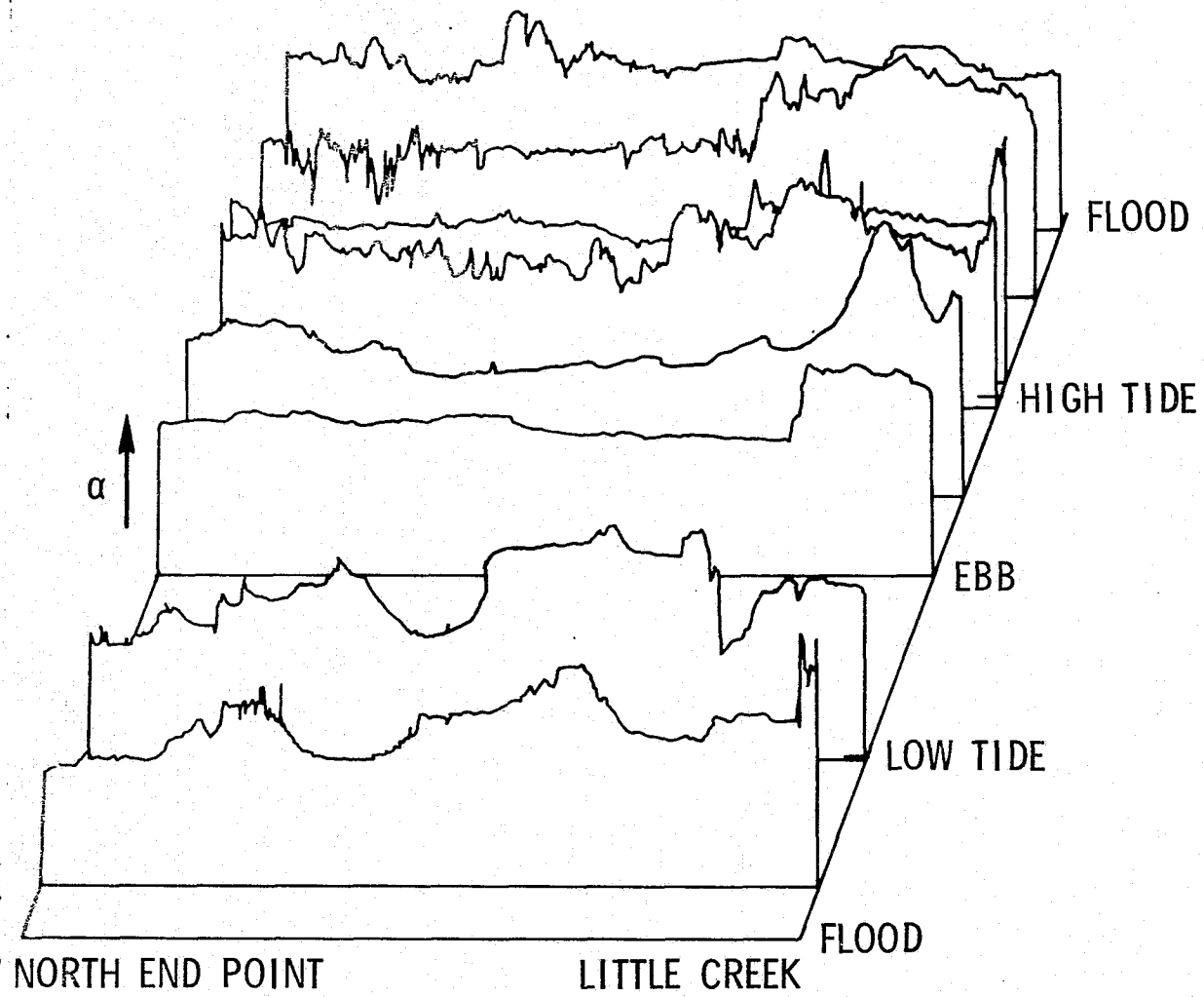

Figure 19. Plot of attenuation coefficient along baseline 3 as a function of tidal cycle.

New correlation coefficients were determined for the three overpasses by selecting different baseline data as suggested. Table 8 gives the original correlation and the new correlations for each set of data, with the  $\alpha$  baseline shown in brackets. February 13 was not included due to the severe banding in the radiance data. There is an improvement in correlation with each baseline when tidal variations are considered. The average correlations for baselines 2 and 3, for instance, have just about doubled.

#### SUMMARY AND CONCLUDING REMARKS

The application of LANDSAT-1 MSS data to the lower Chesapeake Bay area has clearly been demonstrated. Bands (5-6) were shown to be useful for monitoring total particles although a daily calibration was necessary. Band 5 had a high correlation with sediment and, unlike particles, a daily calibration was not required when atmospheric corrections could be made. Under favorable conditions, it was found that the MSS data could be used to make an internal correction for atmospheric interference. The relation of sediment to total particles was established by using the MSS radiance values to unite the helicopter and ship data in a common analysis. It was found that the radiance values at each station were more sensitive to particle size than the total number of particles. This probably accounts for the need to calibrate particle-radiance data on a daily basis, whereas sediment, which is dominated by the weight of the large particles, did not require a daily calibration.

A contouring program was developed to display the sediment variation in the lower Bay at the time of the January 26, 1973, overpass. Several features, such as the James River "plume," were evident.

When the continuous recordings of the attenuation coefficient along the baselines were arranged in sequence according to tidal position, a tidal influence on the data seemed evident. A further test of this condition was made by correlating the radiance values along the baselines with surface data collected during the nearest "tidal time," not physical time. The increase in correlation for the baselines was taken as additional evidence of the importance of tides in the coastal zones.

Undoubtedly there are seasonal and temporal features in the baseline  $\alpha$  data which are tending to modify the tidal variations. With a sufficient

Table 8. Correlation Coefficients Between Band 4 Radiance and Baseline Alpha for Given Dates and Nearest Tidal Cycle Dates.

LANDSAT DATE	BASELINE					
	1		2		3	
	(a)	(b)	(a)	(b)	(a)	(b)
JAN. 26	.85		-.02	.19 (FEB. 13)	.16	.44 (APR. 8)
OCT. 5	.74	.86 (JAN. 26)	.51	.73 (FEB. 13)	.35	.63 (MAR. 3)

(a) ORIGINAL VALUES

(b) NEW VALUES (DATE OF SHIPTRANSECT)

number of transects giving good tidal coverage, it should be possible to separate these effects and construct a tidal reference data bank. Thus, satellite remote sensing data could be quickly searched for anomalous conditions resulting from such variables as runoff, storms, pollution, sources, outfalls, etc., which is the primary objective of the remote sensing program.

In summary, the LANDSAT-1 spacecraft has been used to (1) monitor and map physical parameters in the lower Bay waters; (2) establish relations between parameters at remote stations; and (3) demonstrate the time dependence of variations in the marine environment. With such accomplishments by LANDSAT-1, a spacecraft not optimized for detection in the water environment, there most certainly is a positive future for remote sensing in the estuaries.

The results of this study indicate that it is possible for potential users to apply remote sensing on a quantitative basis to suspended matter determinations in estuarine waters. Remote determination of suspended matter concentrations, once calibrated to the estuary in question and adjusted for tidal effects, provides a powerful synoptic tool for users in the areas of water quality control, fisheries, and coastal engineering. Such determinations are made on a routine basis at river gauging stations, but cannot be done in most estuaries because of the prohibitive costs involved. Through long-term accumulation of remote suspended matter concentrations, the above-mentioned users can establish a base from which it will be possible to detect and determine the importance of natural and manmade variations on an estuary. Such variations include excessive run-off from flooding, storm-induced wave suspension and erosion, and pollution sources such as coastal construction, dredging, and industrial discharges.

APPENDIX A  
HELICOPTER  
STATION LOCATIONS

BY

DATE

Oct. 9, 1972

<u>Station No.</u>	<u>Lat</u>	<u>Lon</u>	<u>Place Name</u>
1	36 58 26	76 06 30	Thimble Shoals Channel
2	37 02 27	76 04 08	Middle Island - Chesapeake Bay
3	37 05 17	75 59 13	Fixed Bridge - Chesapeake Bay Bridge
4	37 05 42	75 50 00	Offshore
5	37 15 04	76 03 55	Cherrystone Channel
6	37 23 06	76 02 01	Old Town Neck
7	37 23 24	76 11 22	Wolf Trap Lighthouse
8	37 17 41	76 17 10	New Point Comfort
9	37 13 24	76 19 18	Poquoson Flats
10	37 06 00	76 14 54	Plumtree Bar
11	37 05 37	76 37 09	Rocklanding Channel
12	37 03 04	76 36 57	Burwell Bay
13	36 58 49	76 30 14	James River Bridge
14	37 00 20	76 28 22	James River Bridge (Newport News)
15	36 57 00	76 25 41	Newport News Shipyard
16	36 54 52	76 26 40	Pig Point
17	36 57 50	76 19 57	Sewells Point
18	37 00 11	76 17 37	Old Point Comfort

Dec. 3, 1972

<u>Station No.</u>	<u>Lat</u>	<u>Lon</u>	<u>Place Name</u>
1	36 58 26	76 06 30	Thimble Shoals Channel
2	37 02 27	76 04 08	Middle Island - Chesapeake Bay
3	37 05 17	75 59 13	Fixed Bridge - Chesapeake Bay Bridge
4	37 05 42	75 50 00	Offshore
5	37 15 04	76 03 55	Cherrystone Channel
6	37 23 06	76 02 01	Old Town Neck
7	37 23 24	76 11 22	Wolf Trap Lighthouse
8	37 17 41	76 17 10	New Point Comfort
9	37 13 24	76 19 18	Poquoson Flats
10	37 06 00	76 14 54	Plumtree Bar
11	37 05 37	76 37 09	Rocklanding Channel
12	37 03 04	76 36 57	Burwell Bay
13	36 58 49	76 30 14	James River Bridge
14	37 00 20	76 28 22	James River Bridge (Newport News)
15	36 57 00	76 25 41	Newport News Shipyard
16	36 54 52	76 26 40	Pig Point
17	36 57 50	76 19 57	Sewells Point
18	37 00 11	76 17 37	Old Point Comfort
19			TAG 1-3
20			TAG 2-3
21			TAG 5-3
22			TAG 6-3
23			TAG 8-3
24			TAG 10-3

Dec. 4, 1972

<u>Station No.</u>	<u>Lat</u>	<u>Lon</u>	<u>Place Name</u>
25	37 54 52	76 26 40	Pig Point
26	36 57 00	76 25 41	Newport News Shipyard
27	37 00 20	76 28 22	James River Bridge
28	36 58 49	76 30 14	James River Bridge
29	37 03 04	76 36 57	Burwell Bay
30	37 05 37	76 37 09	Rocklanding Channel
31	37 09 50	76 37 58	Fort Eustis
32	37 11 17	76 39 45	Hog Island
33	37 12 26	76 41 15	Hog Point
34	37 11 28	76 43 42	Goose Hill Channel
35	37 30 07	76 47 16	West Point
36	37 26 53	76 43 26	Harcum VOR Station
37	37 14 59	76 30 44	York River Bridge
38	37 10 36	76 22 17	Poquoson Flats



Jan. 9, 1973

<u>Station No.</u>	<u>Lat</u>	<u>Lon</u>	<u>Place Name</u>
1	36 57 00	76 25 41	Newport News Ship
2	36 54 52	76 26 40	Pig Point
3	37 00 20	76 28 22	James River Bridge N
4	36 59 36	76 29 19	James River Bridge C
5	37 03 04	76 36 57	Burwell Bay
6	37 05 37	76 37 09	Rocklanding Channel

Jan. 26, 1973

<u>Station No.</u>	<u>Lat</u>	<u>Lon</u>
1J	37 00 59	76 27 38
2J	37 00 52	76 27 45
3J	37 00 38	76 28 02
4J	37 00 24	76 28 19
5J	37 00 18	76 28 28
6J	37 00 04	76 28 45
7J	36 59 49	76 29 02
8J	36 59 36	76 29 19
9J	36 59 26	76 29 31
10J	36 59 20	76 29 38
11J	36 59 13	76 29 47
12J	36 59 07	76 29 55
13J	36 59 00	76 30 03
14J	36 58 53	76 30 12
15J	36 58 47	76 30 18
16J	36 58 41	76 30 26
17J	36 58 34	76 30 34
1B	37 04 51	75 59 03
2B	37 04 35	76 00 00
3B	37 04 09	76 00 51
4B	37 03 39	76 01 35
5B	37 03 06	76 02 20
6B	37 02 35	76 03 05
7B	37 02 02	76 03 53
8B	37 01 32	76 04 31
9B	37 00 48	76 05 00
10B	37 00 00	76 05 17
11B	36 59 17	76 05 36
12B	36 58 06	76 07 26
13B	36 57 35	76 08 16
14B	36 57 05	76 09 07
15B	36 56 36	76 09 57
16B	36 56 06	76 10 47

Feb. 13, 1973

<u>Station No.</u>	<u>Lat</u>	<u>Lon</u>
1J	37 00 59	76 27 38
2J	37 00 52	76 27 45
3J	37 00 38	76 28 02
4J	37 00 24	76 28 19
5J	37 00 18	76 28 28
6J	37 00 04	76 28 45
7J	36 59 49	76 29 02
8J	36 59 36	76 29 19
9J	36 59 26	76 29 31
10J	36 59 20	76 29 38
11J	36 59 13	76 29 47
12J	36 59 07	76 29 55
13J	36 59 00	76 30 03
14J	36 58 53	76 30 12
15J	36 58 47	76 30 18
16J	36 58 41	76 30 26
17J	36 58 34	76 30 34
18J	36 58 28	76 30 42
1B	37 04 51	75 59 03
2B	37 04 35	76 00 00
3B	37 04 09	76 00 51
4B	37 03 39	76 01 35
5B	37 03 06	76 02 20
6B	37 02 35	76 03 05
7B	37 02 02	76 03 53
8B	37 01 32	76 04 31
9B	37 00 48	76 05 00
10B	37 00 00	76 05 17
11B	36 59 17	76 05 36
12B	36 58 33	76 05 54
13B	36 57 46	76 06 15
14B	36 56 59	76 06 32
15B	36 56 10	76 06 49

July 7, 1973

<u>Station No.</u>	<u>Lat</u>	<u>Lon</u>	<u>Place Name</u>
1	37 04 08	75 58 56	Red Nun (high bridge on Chesapeake Bay Bridge)
2	37 04 08	75 58 42	Red Nun (high bridge on Chesapeake Bay Bridge)
4	37 04 08	75 50 18	8 Miles Out
5	37 04 08	75 56 46	2 Miles Out
6	37 04 08	75 48 09	10 Miles East
7	37 04 08	75 45 57	12 Miles Out
8	37 04 08	75 43 47	14 Miles Out

July 25, 1973

<u>Station No.</u>	<u>Lat</u>	<u>Lon</u>
1	36 59 56	76 18 45
2	36 59 03	76 17 43
3	36 57 50	76 19 57
4	36 59 18	76 22 48
5	36 56 10	76 25 59
6	36 54 52	76 26 40
8	37 00 27	76 27 45
9	36 58 49	76 30 14
10	37 03 13	76 39 02
11	37 03 54	76 38 07
12	37 08 48	76 37 41
BM1	37 05 27	75 59 23
BM4	37 02 42	76 04 27
BM9	36 58 41	76 05 59
A	36 59 37	76 18 30
B	36 58 03	76 20 25
C	36 57 15	76 24 43
D	37 00 10	76 28 10
E	37 04 52	76 36 37
F	37 09 46	76 38 03

July 26, 1973

<u>Station No.</u>	<u>Lat</u>	<u>Lon</u>
1	36 59 48	76 17 55
2	36 57 06	76 25 21
3	37 00 06	76 28 05
4	37 05 13	76 35 54
5	37 07 02	76 38 21

Aug. 30, 1973

<u>Station No.</u>	<u>Lat</u>	<u>Lon</u>
1	36 58 26	76 06 30
2	37 02 27	76 04 08
3	37 05 17	75 59 13
4	37 07 39	75 55 06
5	37 15 04	76 03 55
6	37 23 06	76 02 01
7	36 55 04	76 26 47
8	36 57 00	76 25 41
9	36 58 49	76 30 14
10	37 00 06	76 28 05
11	37 03 04	76 36 57
12	37 05 37	76 37 09
13	37 06 45	76 38 30

Sept. 17, 1973

<u>Station No.</u>	<u>Lat</u>	<u>Lon</u>	<u>Place Name</u>
1	36 58 26	76 06 30	
2	37 02 27	76 04 08	
3	37 05 17	75 59 13	
4	37 06 54	75 52 30	
5	37 15 04	76 03 55	
6	37 23 06	76 02 01	
7	37 23 24	76 11 22	
8	37 17 41	76 17 10	
9	37 13 24	76 19 18	
10	37 06 00	76 14 54	
11	37 05 37	76 37 09	
12	37 03 04	76 36 57	
13	36 58 49	76 30 14	
14	37 00 20	76 28 22	
15	36 57 00	76 25 41	Pig Point
16	36 55 04	76 26 47	Newport News Shipyard
17	36 57 50	76 19 57	Old Point Comfort
18	37 00 11	76 17 37	Sewells Point



Oct. 5, 1973

<u>Station No.</u>	<u>Lat</u>	<u>Lon</u>	<u>Place Name</u>
1	36 58 26	76 06 30	
2	37 02 27	76 04 08	
3	37 05 17	75 59 13	
4	37 08 51	75 55 18	Buoy 262 - Migothy Bay
5	37 15 04	76 03 55	
6	37 23 06	76 02 01	
7	37 23 24	76 11 22	
8	37 17 41	76 17 10	
9	37 13 24	76 19 18	
10	37 06 00	76 14 54	
11	37 05 37	76 37 09	
12	37 03 04	76 36 57	
13	36 58 49	76 30 14	
14	37 00 20	76 28 22	
15	36 57 00	76 25 41	
16	36 55 04	76 26 47	
17	36 57 50	76 19 57	
18	37 00 11	76 17 37	

Oct. 23, 1973

<u>Station No.</u>	<u>Lat</u>	<u>Lon</u>
7	36 57 09	76 24 54
8	36 57 00	76 25 42
9	36 55 03	76 26 47
10	37 00 34	76 27 30
11	37 00 06	76 28 05
12	36 59 35	76 28 42
13	37 05 13	76 35 59
14	37 04 53	76 36 39
15	37 03 13	76 39 02
16	37 09 55	76 37 03
17	37 09 47	76 38 02
18	37 09 48	76 38 43
19	37 11 48	76 44 09
20	37 11 29	76 43 39
21	37 11 00	76 43 05

APPENDIX B  
METHOD OF  
CHLOROPHYLL ANALYSIS OF  
STRICKLAND AND PARSONS - AMENDED

## Chlorophyll Analysis of Strickland and Parsons-Amended

### OUTLINE OF METHOD

The larger zooplankters are removed by straining a sample of sea water through a nylon net of about 300- $\mu$  mesh size and then the phytoplankters are filtered onto a Millipore AA filter or a glass filter. Pigments are extracted from the algae cells for estimation spectrophotometrically.

### SPECIAL APPARATUS AND EQUIPMENT

Millipore filtration equipment designed to hold 47-mm diameter membrane filters.

One 300-ml polyethylene wash bottle.

Stoppered graduated centrifuge tubes of 15-ml capacity having both glass and polyethylene stoppers.

"Small volume" spectrophotometer cells having a path-length of 5 cm but holding 5 ml or less of solution (1 cm. path length cells will do when chlorophyll values are high.)

### SAMPLING PROCEDURE AND SAMPLE STORAGE

Adequate sampling of the euphotic zone or detrital layers for phytoplankton is a subject which is outside the scope of the present method. Once obtained, the final sample (generally 100 ml to 500 ml in volume) is filtered through a small piece of clean 0.3-mm-mesh nylon netting to remove the larger zooplankton. For open sea samples filtration of small volumes through a 0.15-mm-mesh net will still not retain significant amounts of phytoplankton. The required volume of this filtrate should be measured by a polyethylene measuring cylinder into a polyethylene bottle. About 1 ml of magnesium carbonate suspension is added. The sample may then be stored in a cool dark place for a maximum of about 8 hours. It is desirable, however, that samples be filtered through a membrane filter at the time of collection.

Membrane filters can be stored by folding them in half (with the plankton innermost) and storing them *in the dark* in a desiccator frozen to  $-20^{\circ}\text{C}$  but only for a few weeks. This procedure almost always leads to low results and makes the extraction of chlorophyll more difficult and filters should be extracted without delay if at all possible.

## SPECIAL REAGENTS

### 1. SPECIAL REAGENTS

Distill reagent grade acetone over about 1% of its weight each of anhydrous sodium carbonate and anhydrous sodium sulphite. Collect the fraction boiling at a constant temperature near 56.5°C (uncorrected). 100 ml of water is pipetted into a litre volumetric flask and acetone added to make the volume to exactly 1000 ml. The redistilled acetone should be stored in a tightly stoppered dark glass bottle and the 90% reagent prepared in moderately small amounts (say a litre at a time) for use. This reagent is conveniently dispensed from a polyethylene wash bottle which should be kept nearly full.

### 2. MAGNESIUM CARBONATE SUSPENSION

Add approximately 1 g of finely powdered magnesium carbonate (light weight or "Levis" grade) of analytical reagent quality to 100 ml of distilled water in a stoppered Erlenmeyer flask. Shake vigorously to suspend the powder *immediately* before use.

## EXPERIMENTAL

1. Invert the polyethylene bottle containing the sample into the funnel of the Millipore filter equipment fitted with either a 47-mm diameter Millipore AA (0.8  $\mu$ ) filter or a 4.5-cm Whatman GF/C glass filter paper (Note a). The bottle need not be rinsed but the contents should be shaken vigorously, before filtration is commenced. If not added previously, introduce about 1 ml of magnesium carbonate suspension to the last few hundred millilitres of sample being filtered (Note b).

2. Drain the filter thoroughly under suction before removing it from the filtration equipment and if a Millipore filter is used trim away the peripheral excess of unstained membrane with clean scissors (Note c). Store the filter if necessary but if possible extract the pigment without delay (Sect. D).

3. Place the filter in a 15-ml stoppered graduated centrifuge tube.

If a Millipore filter was used add approximately 8 ml of 90% acetone, stopper and dissolve the filter by shaking the tube vigorously. If a glass paper was used add approximately 10 ml of 90% acetone, stopper and disperse and disintegrate the paper by shaking the tube vigorously (Note d). Allow the pigments to be extracted by placing the tube in a refrigerator in *complete darkness* for about 20 hours (Notes e and f). It is good practice to shake the tubes vigorously once more after they have been an hour or two in the refrigerator.

4. Remove tubes from the refrigerator and let them warm up in the dark nearly to room temperature. Add 90% acetone to make the extracts from Millipore filters up to exactly 10.0 ml and those from glass filters to exactly 12.0 ml (Note g). Centrifuge the content of the tubes for 5-10 minutes (Note h) having replaced the glass stoppers on the centrifuge tubes with plastic stoppers to prevent breakage during centrifugation.

5. Decant the clear supernatant liquid into a 10-cm path-length spectrophotometer cell designed to hold 10 ml or less of liquid. In the event of extinction values exceeding about 1.3 the measurements described below should be made with 2.5-cm or 1-cm cells and the extinction values multiplied by 4 or 10, respectively, to normalize them to the values expected with a 10-cm cell. If 12 ml of acetone is used with glass papers multiply the extinctions value by 1.2 to normalize them to the values expected from 10 ml of extract.

6. Without delay measure the extinction of the solution against a cell containing 90% acetone (Note i) at 7500, 6650, 6450, 6300 and 4800 A (Note j). If the Richards equations are to be used for carotenoids (see below) a further measurement at 5100 A is required. Record the extinction values to the nearest 0.001 unit in the range 0-0.4 and the nearest 0.005 for extinctions exceeding about 0.4. Correct the extinctions at each wavelength by the procedure described in Section G below.

7. Calculate the concentration of pigments in sea water from the equation:

$$\text{mg (or m-S.P.U.) pigment/m}^3 = \frac{C}{V}$$

where  $C$  is a value obtained from the following equations and  $V$  is the volume of sea water filtered in litres. When the Parsons-Strickland equations are used values for chlorophylls  $a$ ,  $b$ , or  $c$  will be in  $\text{mg/m}^3$  and those for carotenoids in a milligram. If the "classical" Richards equations are used values are in  $\text{mg/m}^3$  only for chlorophylls  $a$  and  $b$ . The Richard m-S.P.U. is used for chlorophyll  $c$  and is considerably greater than the milligram. The m-S.P.U. is considerably smaller than the milligram if carotenoids are mainly fucoxanthin or peridinin which are present in Chrysophyta or Pyrrophyta.

8. Formulae: ( $R$  = Richards, P.S. = Parsons and Strickland, H.J. = Humphrey and Jeffrey).  $E$  stands for the extinction values, at wavelengths indicated by the subscripts, measured in 10-cm cells *after* correcting for a blank as described in Section G. 2. below.

$$R. \quad C (\text{chlorophyll } a) = 15.6 E_{6650} - 2.0 E_{6450} - 0.8 E_{6300}$$

$$P.S. \quad C (\text{chlorophyll } a) = 11.6 E_{6650} - 1.31 E_{6450} - 0.14 E_{6300}$$

$$H.J. \quad C (\text{chlorophyll } a) = 13.7 E_{6650} - 2.16 E_{6450} + 0.19 E_{6300}$$

$$R. \quad C (\text{chlorophyll } b) = 25.4 E_{6450} - 4.4 E_{6650} - 10.3 E_{6300}$$

$$P.S. \quad C (\text{chlorophyll } b) = 20.7 E_{6450} - 4.34 E_{6650} - 4.42 E_{6300}$$

$$H.J. \quad C (\text{chlorophyll } b) = 22.2 E_{6450} - 3.88 E_{6650} - 4.72 E_{6300}$$

$$R. \quad C (\text{chlorophyll } c) = 109 E_{6300} - 12.5 E_{6650} - 28.7 E_{6450}$$

$$P.S. \quad C (\text{chlorophyll } c) = 55 E_{6300} - 4.64 E_{6650} - 16.3 E_{6450}$$

$$H.J. \quad C (\text{chlorophyll } c) = 54.6 E_{6300} - 6.00 E_{6650} - 13.7 E_{6450}$$

$$R. \quad C (\text{Plant carotenoids}) = 7.6 (E_{4800} - 1.49 E_{5100}), \text{ without regard to nature of crop.}$$

$$P.S. \quad C (\text{Plant carotenoids}) = 4.0 E_{4800}, \text{ if crop predominately Chlorophyta or Cyanophyta.}$$

$$= 10.0 E_{4800}, \text{ if crop predominately Chrysophyta or Pyrrophyta.}$$

(We used method of Richards)

## NOTES

(a) Millipore filters have the advantage that they dissolve in acetone completely, give no complications at the centrifugation stage, and no particular precautions are necessary during filtration. Unless great care is taken, however, undesirably high blanks will occur when using Millipore filters, making for difficulties in the determination of small concentrations of carotenoids. These filters are expensive. Glass filters are cheaper and their use results in practically no blank. They are recommended if a cell grinding step is required to give better extraction (Note d). However, care must be taken when filtering samples through the comparatively coarse glass filters and trouble is experienced at the centrifugation stage. A manostat (there are several cheap commercial laboratory units based on the cartesian diver) must be used with glass papers to ensure that the suction never exceeds one-quarter of an atmosphere or else pigment may pass through the filters. *Millipore filters must be used if chlorophyll *c* is to be determined on the same extract by method II.1.11.*

(b) The magnesium carbonate is added at this stage to ensure that the phytoplankton chlorophyll is prevented from becoming acid with the resulting decomposition to give pheophytin pigments. We have some doubts of the efficacy of such an addition compared with, say, the addition of a completely soluble organic base but the use of magnesium carbonate is established practice and doubtless has some value as a precautionary measure. Care should be taken to see that Millipore filtration equipment, centrifuge tubes, and the spectrophotometer cells are kept free from acid and that the filter is not touched with acidic fingers.

(c) The troublesome blank, measured at 7500 Å (Sect. G) found with Millipore filters is caused almost entirely by the salt left in the filter at this stage which subsequently "salts out" membrane material from the acetone. The blank can be greatly reduced if filters are sucked dry of seawater very thoroughly at this stage and as much as possible of the unwanted peripheral filter is cut away.

(d) If poor extraction is anticipated use a glass filter and after filtration push this to the bottom of a "Potter" type grinder holding about 20 ml. Following Yentsch and Menzel (*loc. cit.*) we have used the Arthur H. Thomas grinder No. 4288-B fitted to an ordinary laboratory stirring motor. About 2 ml of 90% acetone should be added and the grinder run for 1-2 minutes *in subdued light*. The tube should be pushed up and down the pestle during the extraction but for much of the time the pestle should be hard against the bottom of the tube. After use, the pestle is rinsed into the tube with a few millilitres of 90% acetone which is also used to transfer the content of the grinder tube to a 15-ml centrifuge tube. The total volume in the centrifuge tube should not exceed 10 ml. The contents should be left in the dark for a few hours to ensure the complete removal of all extractable pigments.

(e) During the extraction period pigments are very photosensitive and neither extracts nor the unextracted filters should be exposed to strong sunlight or else chlorophyll values will be reduced to a small fraction of their initial level in less than an hour. Tubes must be stored in complete darkness.

(f) The period of extraction should be about 15-20 hours. After this time the rate of further extraction is too slow for an extension to be merited. Pigment extracts should preferably be kept chilled but they can be kept at room temperature for many hours without deterioration. If cells are pretreated in a grinder (Note d) any further extraction is slow, but for safety, tubes should be stored for a few hours to complete the leaching of cell fragments.

(g) The use of 10 ml of solution in a 10-cm path-length cell is recommended for maximum sensitivity. Greater sensitivity can be obtained by using 10-cm cells containing less than 10 ml but this is scarcely great enough to warrant the increased manipulative difficulties. The ultimate sensitivity is, in practice, more dependent on the size and reproducibility of blanks. Glass filters disintegrate to pulp, instead of dissolving in acetone, and the pulp retains at least 1 ml of solvent. To ensure enough extract to fill a 10-cm cell, therefore, 12 ml of acetone, instead of 10 ml, should be used.

(h) Centrifugation should be as efficient as possible when Millipore filters are used. 3000-4000 r.p.m. for about 10 minutes is generally satisfactory in most small centrifuges but the efficiency should be tested with each instrument used. Difficulties may be encountered when centrifuging down the glass pulp from glass filters. Tubes should be centrifuged for 1-2 minutes to pack most of the fibres to the bottom. The centrifuge is then stopped, the tubes removed, and glass fibres adhering to the walls of the tubes above the level of the solvent are taken down into the bulk of the liquid by gently splashing the walls by flicking the tubes. The tubes are then returned to the centrifuge and spun for about 5 minutes. If this precaution is not taken some fibres held above the solvent layer may enter the spectrophotometer cell.

(i) These extracts should not be allowed to evaporate and should be exposed only to subdued light for the briefest possible period. The measurement of extinction against acetone (instead of against water) is recommended as acetone has markedly less absorption in a 10-cm cell at 7500 Å than has distilled water.

ORIGINAL PAGE IS  
OF POOR QUALITY

(f) The wavelength setting of the spectrophotometer used should be checked against a standard hydrogen or neon line source as the precision of the present method depends upon settings being correct to better than 20 to 30 Å. With quartz prisms at wavelengths exceeding 6000 Å very slight movements of the optical system, brought about by vibrations, etc., can easily result in errors of 50 Å or more in wavelength settings. If a suitable lamp is not available check the extinction of a suitably concentrated plant extract and adjust the spectrophotometer, if necessary, until a maximum extinction is obtained at 6630 Å.

## DETERMINATION OF BLANK

### 1. CELL-TO-CELL BLANKS

As the precise values of comparatively small extinctions have to be measured, corrections for all optical inequalities become important. Fill both spectrophotometer cells with 90% acetone and find the "cell-to-cell" blank of the sample cell against the reference cell *at all wavelengths used in the method*. Correct all extinction values by this cell-to-cell blank which may amount to 0.01 or more.

### 2. TURBIDITY BLANKS

If glass-papers are used there should be only a very small blank. This is measured by the spectrophotometer reading at 7500 where there is known to be no absorption of light from pigments. We have sometimes found a small negative blank for reasons which are not clear. In any case the value positive or negative should not exceed about 0.002 and may be corrected for cell-to-cell blank and used for the extinctions at all wavelengths.

A certain amount of colloidal material remains after the solution of an AA Millipore filter, even after centrifugation. The extinction from this material depends on the wavelength of light used, increasing at shorter wavelengths due to light scattering effects.

The extinction at 7500 Å is corrected for any cell to cell blank at this wavelength and the resulting extinction ( $E_b$ ) is multiplied by a factor  $f$  to give the turbidity blank extinction to be used with spectrophotometer readings at other wavelengths.

$$\text{Total blank correction} = \text{cell-to-cell blank} + (f \times E_b).$$

where  $f$  has the values shown below:

Wavelength	$f$
6650	1
6450	1
6300	1
5100	2
4800	3

It must be stressed that these values for  $f$  are *very approximate*. Extinction values at 4800 Å should undoubtedly be corrected by a greater blank than the one obtained at 7500 Å but the value of 3 is so approximate that there is no substitute for having low  $E_b$  values. If a good correction is required  $E_b$  must not exceed about 0.02.



APPENDIX C  
CHLOROPHYLL ANALYSES

## Chlorophyll - October 9, 1972

mg/m<sup>3</sup>

<u>Station No.</u>	<u>A</u>	<u>B</u>	<u>C</u>	<u>CAR</u>	<u>Total</u>
1	19.6	19.0	120	1.03	159
2	16.2	13.6	94.1	1.18	124
3	2.40	1.35	6.94	.0341	10.7
4	2.39	1.17	8.89	.0814	12.4
5	2.56	1.26	10.2	.108	14.1
6	7.66	6.04	34.5	.327	48.2
7	5.31	4.60	30.6	.225	40.5
8	3.63	1.93	11.7	.107	17.2
9	4.08	3.61	16.5	.147	24.2
10	5.87	2.85	19.8	.229	28.6
11	26.9	38.3	287	1.85	352
12	5.34	2.24	12.4	.161	20
13	2.99	1.92	8.99	.0831	13.9
14	3.35	1.62	9.81	.0763	14.7
15	2.87	.420	24.9	.0536	28.2
16	2.98	1.78	10.4	.0473	15.2
17	3.17	2.35	12.1	.0933	17.6
18	22.3	17.6	115	.859	155

## Chlorophyll - December 3, 1972

mg/m<sup>3</sup>

<u>Station No.</u>	<u>A</u>	<u>B</u>	<u>C</u>	<u>CAR</u>	<u>Total</u>
1	4.70	4.40	28.6	.1716	37.8
2	4.72	4.34	26.4	.1734	35.6
3	4.00	2.94	21.6	.200	28.6
4	2.54	2.20	15.62	.1336	20.2
5	3.56	2.78	20.0	.1568	26.4
6	4.32	3.16	22.4	.252	30.0
7	2.06	1.044	8.38	.1150	11.48
8	2.58	1.804	12.82	.1266	17.20
9	3.16	2.68	19.10	.1438	24.8
10	4.38	3.64	21.2	.1772	29.2
11	2.88	2.88	18.68	.1644	24.4
12	2.38	2.52	16.08	.1258	20.8
13	3.24	3.00	19.84	.1352	26.0
14	3.40	3.16	20.8	.1360	27.4
15	3.62	3.10	20.6	.1528	27.4
16	3.90	3.22	21.6	.1684	28.8
17	5.08	4.50	28.4	.218	38.0
18	6.94	6.02	40.2	.342	53.0
19	7.78	6.60	42.6	.288	57.0
20	3.40	2.76	19.74	.1862	25.8
21	7.66	6.54	43.6	.390	57.8
22	3.70	3.24	22.2	.226	29.2
23	4.68	3.90	25.4	.268	34.0
24	5.24	4.48	30.4	.320	40.2

## Chlorophyll - December 4, 1972

mg/m<sup>3</sup>

<u>Station No.</u>	<u>A</u>	<u>B</u>	<u>C</u>	<u>CAR</u>	<u>Total</u>
25	8.42	7.48	48.0	.394	63.8
26	1.924	1.784	13.80	.1288	17.52
27	7.86	6.66	4.54	.448	60.0
28	9.68	8.50	54.8	.482	73.0
29	2.96	3.08	22.4	.222	28.4
30	7.58	6.56	42.6	.356	56.6
31	5.82	5.14	38.0	.378	49.0
32	7.04	6.60	43.2	.452	57.0
33	4.08	3.68	25.2	.1926	33.0
34	5.10	4.76	31.8	.376	41.8
35	7.90	6.56	43.8	.340	58.4
36	8.64	7.36	47.4	.448	63.4
37	7.16	6.16	43.8	.368	57.2
38	12.44	10.72	71.4	.616	94.4

Chlorophyll - January 9, 1973 (James River flight only)

mg/m<sup>3</sup>

<u>Station No.</u>	<u>A</u>	<u>B</u>	<u>C</u>	<u>CAR</u>	<u>Total</u>
1	.787	.666	5.47	.0684	6.92
2	1.34	.692	6.34	.073	8.38
3	.888	.684	5.96	.0634	7.54
4	1.58	1.094	7.44	.0754	10.12
5	1.164	.952	6.7	.0682	8.82
6	.348	.516	3.82	.0486	4.68

## Chlorophyll - January 26, 1973

mg/m<sup>3</sup>

<u>Station No.</u>	<u>A</u>	<u>B</u>	<u>C</u>	<u>CAR</u>	<u>Total</u>
1J	2.324	1.28	8.68	.1040	12.28
2J	2.06	1.32	7.16	.0856	10.52
3J	2.44	1.284	10.36	.1116	14.08
4J	2.032	1.460	7.92	.0956	11.40
5J	1.776	1.068	8.68	.0896	11.52
6J	2.000	1.504	9.68	.1080	13.20
7J	2.120	1.608	10.32	.1228	14.04
8J	2.412	1.580	10.40	.1376	14.40
9J	1.664	1.068	7.04	.0608	9.76
10J	3.528	2.500	17.92	.1792	23.92
11J	1.244	.916	8.04	.0900	10.20
12J	1.880	1.404	9.04	.1084	12.32
13J	1.756	1.304	8.40	.0788	11.48
14J	2.144	1.424	9.96	.0832	13.56
15J	2.148	1.464	9.56	.0816	13.16
16J	2.420	1.524	10.08	.0896	14.04
17J	2.948	1.784	11.88	.1120	16.64
18ZJ	2.948	1.784	11.88	.1056	16.64
1B	1.78	.0904	2.32	.0428	4.0
2B	1.414	.996	2.14	.0444	3.46
3B	1.774	1.040	.514	.0516	3.32
4B	1.362	.208	1.648	.0478	2.80
5B	1.480	.0161	1.928	.0422	3.42
6B	1.064	.124	1.886	.0498	2.82

(continued)

## Chlorophyll - January 26, 1973 (concluded)

mg/m<sup>3</sup>

<u>Station No.</u>	<u>A</u>	<u>B</u>	<u>C</u>	<u>CAR</u>	<u>Total</u>
7B	2.36	.0430	3.34	.0778	5.68
8B	2.16	.0878	2.48	.0702	4.56
9B	2.34	.438	2.18	.0854	4.08
10B	2.54	.1624	2.66	.0738	5.06
11B	2.00	.220	2.22	.0796	4.00
12B	1.958	.316	1.962	.0568	3.60
13B	1.970	.0966		.0622	3.54
14B	2.30	.0137	2.68	.0396	4.96
15B	2.26	.1922	2.72	.0428	5.20
16B	2.34	.234	2.40	.0486	5.00
17B	2.66	.264	2.62	.0556	5.56
18B	2.40	.406	3.20	.0598	6.02
19B-X	2.16	.474	3.40	.0686	6.04
20B-Y	3.34	.416	3.46	.0304	7.24

## Chlorophyll - February 13, 1973

mg/m<sup>3</sup>

<u>Station No.</u>	<u>A</u>	<u>B</u>	<u>C</u>	<u>CAR</u>	<u>Total</u>
1J	.310	2.04	17.74	.1658	20.0
2J	.1988	.1566	15.02	.1088	15.38*
3J	.546	1.498	10.92	.1632	12.96
4J	1.050	2.60	13.28	.0884	15.88*
5J	1.516	1.912	1.948	.0502	5.36
6J	.262	.238	9.46	.0982	9.48
7J	.604	.950	6.42	.0984	7.98
8J	.970	.1540	5.88	.236	7.50
9J	.1354	.0720	16.50	.1600	16.28
10J	.610	.396	11.02	.1136	12.04
11J	1.248	.520	4.22	.1450	5.98
12J	.276	.322	3.62	.1426	4.22
13J	.598	.630	8.66	.1548	9.90
14J	.814	.388	5.50	.1830	6.70
15J	.608	.222	5.58	.1352	5.98
16J	.526	.0542	2.16	.0930	2.62
17J	1.130	.0526	4.34	.1964	5.42
18J	.642	.1042	3.64	.1258	4.18
Blank					
1B	2.72	1.772	5.32	.0754	9.80
2B	1.940	.710	6.10	.0754	8.76
3B	3.00	1.342	5.70	.0286	10.06

(continued)

\* Chlorophyll sample ~ 10% too large.



Chlorophyll - February 13, 1973 (concluded)

mg/m<sup>3</sup>

<u>Station No.</u>	<u>A</u>	<u>B</u>	<u>C</u>	<u>CAR</u>	<u>Total</u>
4B	2.44	1.186	7.94	.1038	11.60
5B	3.50	2.22	13.84	.1188	19.60
6B	4.02	1.982	13.24	.1214	19.26
7B	3.12	1.130	8.98	.1082	13.26
8B	2.88	3.74	19.14	.1012	25.6
9B	6.12	3.44	23.0	.1968	32.6
10B	5.70	2.98	25.8	.1906	34.6
11B	1.688	3.88	16.62	.1078	22.2
12B	3.70	2.54	13.78	.0952	20.0
13B	4.24	2.48	20.2	.1622	27.0
14B	5.76	3.44	23.0	.1850	32.2
14*	5.92	3.48	22.6	.1882	32.2
15B	4.20	1.508	11.32	.1528	17.04
15*	4.20	1.452	11.92	.1422	17.56
X-TAG	3.52	1.016	7.12	.1144	11.66

---

\* Chlorophyll sample ~ 10% too large.

## Chlorophyll - July 7, 1973 (off shore)

mg/m<sup>3</sup>

<u>Station No.</u>	<u>A</u>	<u>B</u>	<u>C</u>	<u>CAR</u>	<u>Total</u>
1	0.898	0.325	3.16	0.0879	4.38
2	1.44	0.974	6.38	0.152	8.80
3	0.0556	0.0464	0.294	0.00161	0.396
4	0.0	0.0	0.0	0.0	0.0
5	2.85	2.38	15.1	0.134	20.3
6	1.16	0.961	7.57	0.182	9.69
7	0.241	0.430	2.52	0.0628	3.20
8	0.278	0.232	1.47	0.0428	1.98

## Chlorophyll - July 25, 1973

mg/m<sup>3</sup>

<u>Station No.</u>	<u>A</u>	<u>B</u>	<u>C</u>	<u>CAR</u>	<u>Total</u>
1	7.0	2.11	12.8	.159	21.9
2	6.66	2.64	17.0	.214	26.3
3	8.40	2.54	14.6	.234	25.6
4	6.59	2.63	21.5	.249	30.7
5	6.73	2.76	12.3	.170	21.8
6	7.49	2.02	15.0	.180	24.5
8	3.82	.814	7.26	.177	11.8
9	7.23	3.27	23.2	.181	33.7
10	1.39	1.03	8.91	.0307	11.3
11	2.51	.706	12.7	.160	14.5
12	4.62	1.40	18.6	.324	24.6
BM1	5.84	1.45	8.46	.222	15.7
BM4	9.94	5.04	30.7	.472	45.7
BM9	27.3	19.5	141	.135	188
A	9.51	3.34	20.5	.301	33.3
B	7.29	3.13	20.1	.233	30.5
C	2.47	1.17	17.6	.152	18.9
D	9.85	7.63	34.7	.232	52.2
E	5.56	2.53	27.2	.209	30.2
F	7.89	4.12	22.7	.268	34.7

## Chlorophyll - July 26, 1973

mg/m<sup>3</sup>

<u>Station No.</u>	<u>A</u>	<u>B</u>	<u>C</u>	<u>CAR</u>	<u>Total</u>
1	16.8	8.16	65.9	.961	90.9
2	18.6	10.2	74.4	1.12	103
3	2.61	1.70	12.7	.188	17.0
4	13.2	7.56	55.3	.912	76.1
5	1.75	1.07	7.17	.106	10.0
Blank	.231	.615	14.2	.239	14.6

## Chlorophyll - August 30, 1973

mg/m<sup>3</sup>

<u>Station No.</u>	<u>A</u>	<u>B</u>	<u>C</u>	<u>CAR</u>	<u>Total</u>
1	3.45	2.57	17.3	.142	23.4
2	3.33	2.96	15.6	.0934	21.9
3	5.49	4.62	27.9	.136	38.0
4	3.27	2.10	15.0	.128	20.4
5	2.24	1.76	13.5	.108	17.6
6	3.19	2.58	17.4	.152	23.2
7	6.03	4.24	29.1	.188	39.4
8	3.00	2.37	16.2	.123	21.6
9	2.88	1.80	10.7	.0897	15.4
10	1.81	1.24	6.81	.0619	9.87
11	1.34	.205	2.35	.0557	3.89
12	3.97	3.20	21.2	.134	28.4
13	.242	.0399	.398	.00998	.600
14	.00556	.00464	.0294	.000161	.0396

## Chlorophyll - September 17, 1973

mg/m<sup>3</sup>

<u>Station No.</u>	<u>A</u>	<u>B</u>	<u>C</u>	<u>CAR</u>	<u>Total</u>
1	1.10	.141	2.59	.0408	3.55
2	.959	.325	2.96	.0352	4.25
3	.900	.0891	1.07	.0309	2.06
4	1.82	.445	4.54	.0618	6.81
5	1.20	.491	3.89	.0599	5.58
6	1.24	.130	3.10	.0538	4.21
7	1.71	.657	5.46	.0611	7.83
8	1.93	.256	3.24	.0600	5.43
9	1.50	.574	4.75	.0501	6.83
10	2.18	.386	4.31	.0561	6.87
11	.965	.469	4.09	.0409	5.53
12	1.70	1.28	7.04	.0547	10.0
13	1.33	1.05	9.61	.0694	12.0
14	2.31	1.44	9.16	.0860	12.9
15	1.38	.455	5.28	.0543	7.12
16	1.13	.364	3.88	.0293	5.38
17	1.39	1.17	10.5	.0855	13.1
18	1.20	.334	4.36	.0402	5.90
19	.00556	.00464	.0294	.000161	.0396

## Chlorophyll - October 5, 1973

mg/m<sup>3</sup>

<u>Station No.</u>	<u>A</u>	<u>B</u>	<u>C</u>	<u>CAR</u>	<u>Total</u>
1	1.38	.902	6.20	.463	8.49
2	1.94	1.38	8.79	.103	12.1
3	1.35	.861	5.87	.0496	8.09
4	1.25	1.00	6.07	.0407	8.33
5	1.56	1.11	7.68	.0631	10.3
6	1.51	1.11	7.20	.0627	9.83
7	1.84	.908	6.49	.0640	9.25
8	2.11	1.14	8.56	.0947	11.8
9	1.96	1.00	7.37	.0538	10.3
10	1.33	.716	7.94	.0791	11.1
11	1.57	1.21	8.09	.0709	10.8
12	1.77	1.29	8.87	.0760	11.9
13	1.41	1.06	6.85	.0636	9.33
14	1.63	1.31	6.67	.0673	9.61
15	1.55	1.07	7.47	.0774	10.1
16	1.63	.799	5.12	.0618	7.56
17	1.42	.836	5.52	.0385	7.78
18	1.29	.830	5.48	.0462	7.60
19	.740	.645	3.90	.0187	5.28

## Chlorophyll - October 23, 1973

mg/m<sup>3</sup>

<u>Station No.</u>	<u>A</u>	<u>B</u>	<u>C</u>	<u>CAR</u>	<u>Total</u>
7	1.55	1.18	7.60	.0678	10.3
8	1.63	1.14	7.18	.0575	9.97
9	1.63	1.13	6.63	.0608	9.39
10	1.58	1.19	7.99	.0670	10.7
11	1.76	.979	6.19	.0561	8.93
12	1.23	.749	4.40	.0373	6.39
13	1.10	.884	5.03	.0497	7.02
14	1.19	.402	3.15	.0342	4.75
15	1.20	.885	5.71	.0514	7.81
16	.794	.529	3.55	.0272	4.88
17	.175	.0649	.557	.0316	.798
18	.204	.111	.979	.0276	1.29
19	.121	.0181	.721	.0106	.824
20	.270	.164	.796	.0237	1.23
21	.247	.108	.847	.0261	1.20
22	.00556	.00464	.0294	.00461	.0396



APPENDIX D  
PARTICLE COUNT ANALYSES

Particle Count - October 9, 1972

Particles ( $\times 10^6$ ) Per Liter

<u>Station No.</u>	<u>0 - 0.5</u>	<u>0.5 - 1</u>	<u>1 - 2</u>	<u>2 - 4</u>	<u>4 - 8</u>	<u>8 - 16</u>	<u>Total</u>
1	15.4	144	84	25.9	4.32	0.0	271
2	21.0	79.7	41.4	21.6	8.03	.618	163
3	3.70	31.5	31.5	11.1	1.23	0.0	77.8
4	7.41	56.8	63.0	19.7	12.3	0.0	157
5	19.7	73.5	69.2	11.1	12.9	0.0	184
6	9.27	61.1	33.9	13.5	1.85	0.0	119
7	79.7	260	200	222	116	27.1	897
8	35.8	60.5	19.7	9.88	5.56	1.85	133
9	9.88	74.1	28.4	3.70	0.0	0.0	114
10	12.3	108	59.3	30.2	4.94	3.70	213
11	9.88	173	194	67.3	29.0	8.03	481
12	37.0	477	349	158	50.6	8.03	1070
13	20.3	73.5	56.8	33.9	9.27	3.70	191
14	33.9	185	315	266	132	21.6	945
15	24.7	237	155	34.6	16.0	0.0	464
16	6.18	57.4	42.6	3.70	2.47	0.0	110
17	11.1	112	88.9	45.7	8.03	0.0	262
18	3.70	23.4	23.4	6.18	.618	0.0	56.8

Particle Count - December 3, 1972

Particles ( $\times 10^6$ ) Per Liter

<u>Station No.</u>	<u>0 - 0.5</u>	<u>0.5 - 1</u>	<u>1 - 2</u>	<u>2 - 4</u>	<u>4 - 8</u>	<u>8 - 16</u>	<u>Total</u>
1	.618	0.0	4.94	4.94	16.6	2.47	32.7
2	1.85	1.85	21.6	21.6	12.3	16.0	84.6
3	1.23	3.09	14.2	6.18	6.79	4.94	40.1
4	1.85	1.23	9.27	12.3	4.94	3.70	36.4
5	1.23	0.0	7.41	11.1	11.7	3.70	35.8
6	0.0	0.0	3.70	6.18	4.94	.618	16.6
7	0.0	0.0	6.79	6.18	6.18	1.23	20.3
8	0.0	1.85	3.09	4.94	2.47	0.0	12.3
9	2.47	1.85	39.5	44.4	16.0	8.03	113
10	0.0	1.23	16.6	20.3	10.5	4.94	56.8
11	5.56	6.79	45.1	35.2	26.5	4.94	124
12	1.85	5.56	59.9	66.1	22.2	49.4	183
13	3.70	3.70	25.3	28.4	2.47	22.8	82.8
14	.618	4.94	24.7	37.6	12.3	3.70	88.9
15	.618	1.85	15.4	16.0	9.88	1.85	46.9
16	1.85	3.70	28.4	38.3	17.9	8.65	101
17	1.23	1.23	29.0	16.6	11.7	4.94	67.9
18	.618	0.0	16.6	16.0	7.41	1.23	42.6
19	0.0	0.0	8.03	7.41	1.85	.618	19.7
20	.618	.618	7.41	11.1	8.03	2.47	31.5
21	0.0	1.85	4.32	14.8	8.65	6.18	48.8
22	9.88	4.94	55	49.4	49.4	3.70	199
23	.618	.618	6.18	17.9	6.79	4.32	36.4
24	0.0	.618	10.5	5.56	6.18	3.09	29.0

Particle Count - December 4, 1972

Particles ( $\times 10^6$ ) Per Liter

<u>Station No.</u>	<u>0 - 0.5</u>	<u>0.5 - 1</u>	<u>1 - 2</u>	<u>2 - 4</u>	<u>4 - 8</u>	<u>8 - 16</u>	<u>Total</u>
25	0.0	.618	10.5	9.27	3.09	0.0	25.3
26	0.0	1.23	9.88	9.27	5.56	.618	27.8
27	1.23	2.47	42	28.4	23.4	-21	119
28	3.09	3.70	21.6	27.1	14.2	4.94	77.8
29	0.0	3.70	18.5	29	8.65	1.23	64.8
30	6.79	1.85	1.23	9.27	11.7	6.18	46.3
31	1.23	.618	4.32	11.1	10.5	11.1	61.1
32	1.23	0.0	.618	1.85	2.47	6.18	22.2
33	6.79	6.18	27.8	20.3	21.0	0.0	116
34	7.41	8.03	12.3	6.18	8.03	5.56	53.1
35	3.09	1.85	27.1	29.0	16.6	4.32	89.6
36	3.09	1.85	12.3	6.18	4.32	-4.07	58.0
37	4.94	2.47	9.88	6.79	8.65	7.41	39.5
38	-45.7	3.70	32.1	12.9	29.6	2.47	35.8

Particle Count - January 9, 1973 (James River flight only)

Particles ( $\times 10^6$ ) Per Liter

<u>Station No.</u>	<u>0 - 0.5</u>	<u>0.5 - 1</u>	<u>1 - 2</u>	<u>2 - 4</u>	<u>4 - 8</u>	<u>8 - 16</u>	<u>Total</u>
1	1.85	9.88	16.6	4.32	3.70	5.56	45.7
2	8.65	33.9	47.5	25.3	23.4	16.0	167
3	3.70	14.8	28.4	17.3	4.94	2.47	71.6
4	7.41	38.9	56.8	33.3	15.4	2.47	156
5	3.09	13.5	18.5	15.4	7.41	.185	57.4
6	3.70	24.1	29.6	18.5	9.27	3.70	87.7

Particle Count - January 26, 1973

Particles ( $\times 10^6$ ) Per Liter

<u>Station No.</u>	<u>0 - 0.5</u>	<u>0.5 - 1</u>	<u>1 - 2</u>	<u>2 - 4</u>	<u>4 - 8</u>	<u>8 - 16</u>	<u>Total</u>
1J	1.23	2.47	15.4	58.0	11.1	5.56	96.4
2J	3.70	12.3	18.5	40.1	8.65	4.94	92.6
3J	8.03	17.3	14.8	9.27	4.32	3.70	59.3
4J	8.65	17.3	19.1	12.9	4.32	2.47	65.5
5J							
6J	9.27	21.6	14.2	9.88	4.32		66.1
7J	7.41	15.4	21.6	11.1	6.79	1.23	65.5
8J	9.88	18.5	18.5	11.7	4.94	1.23	67.9
9J	30.8	77.2	45.7	37.6	33.9	3.09	231
10J	9.27	38.3	16.6	-14.8	21.0	1.48	86.5
11J	7.41	24.7	22.2	14.8	7.41	.618	80.9
12J	6.18	5.56	7.41	14.2	4.94	1.23	38.9
13J	6.18	34.6	19.7	14.8	11.7	.618	85.2
14J	4.32	44.4	23.4	18.5	8.65	5.56	110
15J	6.79	32.1	35.2	26.5	14.8	3.70	116
16J	3.70	24.1	21.6	24.7	6.79		94.5
17J	9.27	55.0	38.3	27.8	12.9	5.56	153
18ZJ							
1B	2.47	3.70	6.18	6.18	1.23	0.0	18.5
2B	1.23	3.70	5.56	5.56	1.23		17.3
3B	.618	3.09	4.32	6.79	3.70	.618	19.1
4B	1.23	1.23	3.70	5.56	1.23	0.0	11.7
5B	1.23	2.47	6.79	2.47	3.70	0.0	16.0
6B	0.0	12.3	13.5	5.56	4.32	.618	37.0
7B	1.23	2.47	3.70	9.27	.618	.618	17.3

(continued)

Particle Count - January 26, 1973 (concluded)

Particles ( $\times 10^6$ ) Per Liter

<u>Station No.</u>	<u>0 - 0.5</u>	<u>0.5 - 1</u>	<u>1 - 2</u>	<u>2 - 4</u>	<u>4 - 8</u>	<u>8 - 16</u>	<u>Total</u>
8B	.618	5.56	3.70	4.32	3.70	3.70	21.0
9B	.618	4.32	3.09	3.09	4.94	.618	16.6
10B	1.23	2.47	6.79	4.32	4.32	1.23	19.7
11B	.618	1.23	5.56	9.88	.618	0.0	17.9
12B	1.23	4.94	6.18	4.94	2.47	.618	19.7
13B	4.32	3.70	10.5	3.70	3.09	1.23	26.5
14B	.618	4.94	4.94	4.94	3.70	4.94	24.1
15B	9.27	8.03	15.4	8.65	2.47	0.0	42.0
16B	6.79	8.03	8.65	4.94	6.79	.618	33.9
17B	-11.7	58	39.5	29.6	14.2		153
18B	4.32	11.1	9.88	3.70	7.41		38.3
19B-X							
20B-Y							

Particle Count - February 13, 1973

Particles ( $\times 10^6$ ) Per Liter

<u>Station No.</u>	<u>0 - 0.5</u>	<u>0.5 - 1</u>	<u>1 - 2</u>	<u>2 - 4</u>	<u>4 - 8</u>	<u>8 - 16</u>	<u>Total</u>
1J	1.85	12.3	8.65	-53.1	61.7	3.70	34.6
2J	3.00	4.32	10.5	6.79	1.85	0.0	26.5
3J	3.09	4.94	12.3	4.32	4.94	0.0	29.6
4J	6.18	8.03	6.79	7.41	2.47	0.0	29.6
5J	3.70	9.27	10.5	4.94	3.09	.618	32.1
6J	2.47	11.7	14.8	11.7	1.85	1.85	43.8
7J	3.09	14.2	9.27	11.7	4.32	0.0	41.4
8J	8.65	22.8	11.7	14.2	9.88	1.23	68.5
9J	4.32	12.9	12.3	5.56	3.70	0.0	37.6
10J	8.65	13.5	9.27	9.27	5.56	0.0	46.3
11J	2.47	7.41	12.9	10.5	3.09	1.23	37.6
12J	4.94	14.2	12.3	4.94	2.47	0.0	38.3
13J	4.94	10.5	14.8	6.18	3.70	0.0	38.9
14J	6.18	17.3	16.6	9.27	9.27	0.0	58.0
15J	6.18	12.9	14.2	14.2	.618	.618	46.9
16J	3.70	7.41	14.8	9.88	1.23	1.23	38.3
17J	3.09	8.65	24.1	8.03	4.32	0.0	48.2
18J	1.23	8.03	19.1	11.7	3.09	0.0	42.6
Blank	.618	1.85	0.0	.618	0.0	0.0	3.09
1B	1.85	3.09	7.44	2.47	2.47	.618	18.5
2B	1.23	6.18	9.88	4.32	3.09	1.85	27.1
3B	2.47	1.23	4.32	3.70	1.23	0.0	12.9
4B	0.0	2.47	6.79	5.56	1.23	0.0	16
5B	0.0	4.32	4.94	4.94	.618	.618	15.4
6B	0.0	5.56	1.23	6.79	0.0	1.23	14.8

(continued)



Particle Count - February 13, 1973 (concluded)

Particles ( $\times 10^6$ ) Per Liter

<u>Station No.</u>	<u>0 - 0.5</u>	<u>0.5 - 1</u>	<u>1 - 2</u>	<u>2 - 4</u>	<u>4 - 8</u>	<u>8 - 16</u>	<u>Total</u>
7B	2.47	3.09	7.41	3.09	2.47	1.23	19.7
8B	.618	4.94	4.94	7.41	0.0	0.0	17.3
9B	.618	3.09	6.18	4.32	3.09	0.0	17.3
10B	.618	4.32	6.18	4.32	.618	0.0	16
11B	.618	2.47	3.70	6.18	.618	0.0	13.5
12B	.618	3.09	3.09	3.09	3.70	0.0	13.5
13B	0.0	3.09	8.03	8.03	0.0	.618	19.7
14B	1.23	4.32	3.09	7.41	1.85	.618	18.5
14*	.618	2.47	8.65	6.18	1.23	.618	19.7
15B	.618	.618	6.79	5.56	3.70	0.0	16.6
15*	.618	8.03	5.56	3.70	2.47	1.85	21.6

X-TAG

Particle Count - July 7, 1973 (Off Shore)

Particles ( $\times 10^6$ ) Per Liter

<u>Station No.</u>	<u>0 - 0.5</u>	<u>0.5 - 1</u>	<u>1 - 2</u>	<u>2 - 4</u>	<u>4 - 8</u>	<u>8 - 16</u>	<u>Total</u>
1	1.23	0.618	22.8	19.7	6.79	1.85	53.7
2	0.618	7.41	12.9	6.79	0.0	0.0	29.0
3	0.618	3.09	10.5	3.09	0.0	6.79	25.3
4	2.47	12.9	9.88	5.56	2.47	9.88	47.5
5	3.09	16.0	8.03	8.03	2.47	4.94	42.6
6	0.0	11.7	6.79	0.618	0.0	0.618	19.7
7	2.47	10.5	6.79	1.85	3.09	1.23	25.3
8	4.32	14.8	9.88	3.70	2.47	1.23	35.8

Particle Count - July 25, 1973

Particles ( $\times 10^6$ ) Per Liter

<u>Station No.</u>	<u>0 - 0.5</u>	<u>0.5 - 1</u>	<u>1 - 2</u>	<u>2 - 4</u>	<u>4 - 8</u>	<u>8 - 16</u>	<u>Total</u>
1	9.88	2.47	21.6	48.8	21.0	9.27	118
2	.618	1.85	6.79	25.9	15.4	3.09	63
3	1.85	3.09	12.9	23.4	16.0	6.79	79.1
4	1.23	0.0	10.5	19.7	14.2	6.18	61.7
5	8.65	4.32	16.0	34.6	23.4	6.79	97.0
6	6.18	1.23	28.4	59.9	63.0	22.2	194
8	0.0	2.47	41.4	91.4	45.7	18.5	213
9	0.0	.618	93.3	218	111	57.4	509
10	0.0	0.0	75.3	253	95.7	49.4	498
11	0.0	0.0	60.5	170	76.6	26.5	354
12	0.0	4.32	85.2	193	82.8	42.0	427
BM1	.618	0.0	12.9	37.6	22.8	9.88	92.6
BM4	0.0	.618	6.18	9.88	9.27	9.88	50.0
BM9	.618	2.47	11.7	20.3	6.79	8.03	61.1
A	0.0	.618	3.09	11.7	8.03	3.09	35.2
B	0.0	3.09	3.70	6.18	13.5	11.1	48.2
C	0.0	1.85	33.3	90.2	51.2	10.5	205
D	0.0	0.0	4.32	11.7	8.03	1.85	33.9
E	11.7	6.18	41.4	77.8	31.5	17.3	200
F	0.0	3.09	11.1	18.5	16.0	16.0	82.1

Particle Count - July 26, 1973

Particles ( $\times 10^6$ ) Per Liter

<u>Station No.</u>	<u>0 - 0.5</u>	<u>0.5 - 1</u>	<u>1 - 2</u>	<u>2 - 4</u>	<u>4 - 8</u>	<u>8 - 16</u>	<u>Total</u>
1	.618	1.85	1.85	11.7	6.79	7.41	39.5
2	3.09	1.85	8.03	14.8	19.1	9.88	67.3
3	1.23	1.85	8.65	19.7	9.27	4.32	50.0
4	4.94	2.47	4.32	16.6	24.1	11.7	77.8
5	0.0	0.0	16.0	44.4	17.9	7.41	100
Blank	0.0	.618	.618	.618	0.0	0.0	8.03

Particle Count - August 30, 1973

Particles ( $\times 10^6$ ) Per Liter

<u>Station No.</u>	<u>0 - 0.5</u>	<u>0.5 - 1</u>	<u>1 - 2</u>	<u>2 - 4</u>	<u>4 - 8</u>	<u>8 - 16</u>	<u>Total</u>
1	4.32	0.0	11.7	24.1	12.9	8.65	74.1
2	.618	0.0	2.47	6.79	3.09	1.85	21.0
3	0.0	3.70	1.23	6.79	6.18	4.32	33.9
4	0.0	2.47	8.03	27.1	12.3	11.1	77.8
5	.618	.618	1.85	2.47	3.09	3.70	27.1
6	0.0	.618	8.65	9.27	6.79	1.85	29.0
7	0.0	2.47	10.5	19.1	19.7	6.18	72.3
8	0.0	.618	8.03	19.1	9.27	3.09	43.2
9	0.0	.618	9.27	11.1	11.7	10.5	49.4
10	.618	2.47	1.23	8.65	8.03	8.65	35.8
11	0.0	.618	4.94	9.27	8.65	5.56	37.6
12	0.0	0.0	7.41	9.88	6.79	5.56	37.0
13	.618	4.94	2.47	12.9	16.0	8.03	54.3
14	0.0	0.0	.618	0.0	0.0	0.0	4.94

Particle Count - September 17, 1973

Particles ( $\times 10^6$ ) Per Liter

<u>Station No.</u>	<u>0 - 0.5</u>	<u>0.5 - 1</u>	<u>1 - 2</u>	<u>2 - 4</u>	<u>4 - 8</u>	<u>8 - 16</u>	<u>Total</u>
1	0.0	0.0	8.65	54.3	33.9	11.1	111
2	0.0	1.85	2.47	40.7	31.5	11.7	90.8
3	1.23	.618	4.32	37.0	26.5	8.65	82.8
4	0.0	0.0	17.3	78.4	50.6	23.4	174
5	0.0	.618	4.32	21.6	22.2	5.56	57.4
6	0.0	0.0	4.94	36.4	49.4	11.7	111
7	4.32	1.23	1.85	46.3	55.6	19.7	138
8	2.47	1.85	4.94	69.8	45.7	17.9	151
9	3.70	0.0	.618	59.9	64.2	19.1	155
10	2.47	.618	1.23	46.3	48.2	22.2	128
11	0.0	.618	4.32	63.0	60.5	30.8	166
12	0.0	0.0	17.9	97.0	74.7	48.2	253
13	0.0	.618	6.18	43.2	29.0	14.8	100
14	0.0	59.9	100	66.1	37.0	8.03	273
15	1.23	56.8	129	85.2	30.8	4.94	312
16	0.0	50.0	134	74.7	32.1	1.85	297
17	0.0	45.1	124	69.2	20.3	1.23	263
18	.618	39.5	103	57.4	17.3	2.47	224
19	.618	10.5	8.03	1.23	0.0	0.0	20.3

Particle Count - October 5, 1973

Particles ( $\times 10^6$ ) Per Liter

<u>Station No.</u>	<u>0 - 0.5</u>	<u>0.5 - 1</u>	<u>1 - 2</u>	<u>2 - 4</u>	<u>4 - 8</u>	<u>8 - 16</u>	<u>Total</u>
1	0.0	6.18	8.65	6.18	3.70	1.85	27.1
2	4.32	17.9	14.2	6.18	3.70	.618	52.5
3	.618	.618	2.47	1.85	1.85	.618	8.65
4	0.0	1.85	.618	2.47	.618	1.85	16.0
5	0.0	0.0	1.85	2.47	1.23	1.23	7.41
6	1.85	1.23	0.0	0.0	0.0	0.0	3.09
7	1.23	10.5	16.0	16.0	5.56	1.23	50.6
8	.618	6.18	10.5	6.18	6.79	2.47	36.4
9	.618	.618	1.23	5.56	2.47	3.09	12.9
10	5.56	59.9	43.8	21.0	5.56	9.27	145
11	0.0	3.09	8.03	3.70	1.23	.618	16.6
12	14.2	91.4	87.7	24.7	7.41	4.32	222
13	9.27	63.6	68.5	33.9	8.03	2.47	182
14	9.27	67.3	59.3	25.3	9.27	5.56	173
15	1.23	4.32	5.56	3.09	3.70	2.47	21.0
16	6.79	21.6	19.7	9.27	4.32	3.09	65.5
17	0.0	1.23	3.09	1.23	3.09	.618	9.88
18	3.70	17.3	21.6	4.32	.618	4.32	51.9
19	0.0	0.0	0.0	0.0	0.0	0.0	2.47

Particle Count - October 23, 1973

Particles ( $\times 10^6$ ) Per Liter

<u>Station No.</u>	<u>0 - 0.5</u>	<u>0.5 - 1</u>	<u>1 - 2</u>	<u>2 - 4</u>	<u>4 - 8</u>	<u>8 - 16</u>	<u>Total</u>
7	1.55	4.02	1.55	.52	0.0	.21	7.3
8	6.38	11.83	5.87	3.18	.62	0.0	26.8
9	1.65	7.92	3.7	2.37	.93	0.0	16.37
10	.41	2.67	7.62	5.97	2.77	.72	19.8
11	.21	1.24	9.67	5.25	2.15	.72	19.0
12	.21	1.95	10.6	15.75	3.90	.72	33.3
13	0.0	3.08	10.92	8.13	2.98	.52	25.8
14	.41	1.75	15.55	10.92	3.28	1.03	32.8
15	0.0	2.67	14.0	9.67	2.15	.31	28.8
16	.21	3.70	18.0	8.65	3.28	.72	34.5
17	.41	1.05	20.17	8.95	1.75	1.13	42.3
18	.52	4.83	21.33	14.1	4.22	1.55	46.8
19	.21	6.38	29.5	17.5	3.5	.93	58.2
20	.62	9.37	34.5	19.67	4.83	1.55	71.2
21	1.03	2.05	24.33	18.83	5.56	2.77	55.0
22	.21	.31	.103	0.0	0.0	0.0	.62



APPENDIX E  
DESCRIPTION OF TRANSMISSOMETER SYSTEM

## A continuous turbidity monitoring system for coastal surface waters<sup>1</sup>

**Abstract**—A continuous, time-referenced turbidity monitoring system utilizes a keel mounted optical transmissometer with a modified strip chart recorder; it allows detailed study of the distribution of suspended particles in surface waters.

It is of interest to measure turbidity continuously in surface waters of channels, bays, and estuaries. Drake (1972) used an in situ optical transmissometer to monitor turbidity for his studies of the distribution and transport of suspended matter in the Santa Barbara Channel. Ludwick and Melchor (1972) clearly demonstrated the value of spot-monitoring turbidity with an optical transmissometer by delineating many circulation patterns in the mouth of Chesapeake Bay. We have extended the use of the optical transmissometer for surface circulation studies by coupling the instrument to the keel of a research vessel so that turbidity can be monitored continuously over a short time, providing a way of resolving small-scale surface circulation structure over a wide area if repeated traverses of the area are made. Such small-scale surface circulation studies have been almost impossible with spot turbidity measurements, and we have found no similar system reported in the literature. The continuous surface turbidity monitoring system can be used by itself or to complement

<sup>1</sup>This work was supported in part by the National Aeronautics and Space Administration, Earth Resources Technology Satellite programs, contract NAS 5-21816, MMC 299-2.

the traditional technique of spot measurements by vertical casts.

We wish to express our appreciation to J. C. Ludwick and J. R. Melchor for their advice and assistance on the instrument modifications, to T. Gardner for technical help in metal fabrication, and to R. Bray and the crew of the RV *Linwood Holton* for shipboard assistance.

To continuously monitor turbidity we have devised a system that couples a modified dual-beam optical transmissometer probe and an automatic null-balancing circuit with a modified strip chart recorder. It is operated aboard a research vessel on which the transmissometer probe is keel mounted so that it will pass through an undisturbed portion of the top surface layer (Fig. 1).

We measure turbidity with a Bendix/Marine Advisers C-2 transmissometer probe. This instrument gives a direct indication of light transmittance in water, the degree of light attenuation with a fixed-beam path-length, expressed generally as the attenuation coefficient,  $\alpha$ , where

$$\alpha = -\frac{1}{(\text{beam path-length})} \ln(\text{transmittance})$$

for a homogeneous medium. The beam path-length of our probe has been reduced from the standard 1 m to 0.430 m to make it operable in the turbid waters characteristic of the Chesapeake Bay and other estuarine environments. Figure 2 shows the optical construction of the probe. Only

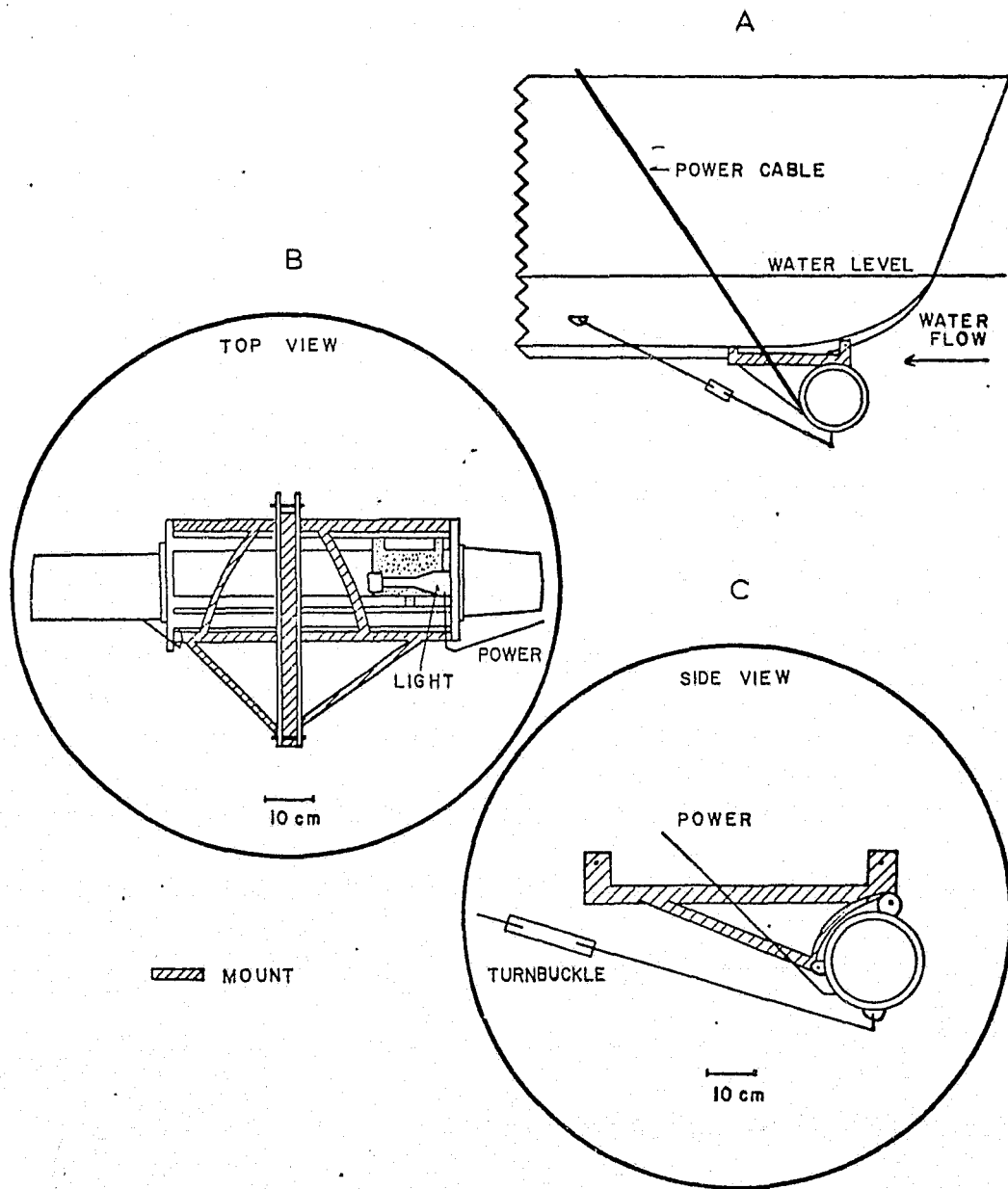

Fig. 1. A. General configuration of the transmissometer probe keel mounted on the research vessel. Not drawn to scale. B. Top view of the transmissometer probe with steel mounting bracket (10 to 1 scale reduction). All joints are welded. C. Side view of the transmissometer probe with steel mounting bracket and 6-mm steel stabilizing cable (10 to 1 scale reduction).

light produced by the source is sensed at the receiver. Two matched Wratten No. 16 filters are used to control the wavelength, yielding for this probe a band-pass of

about 50 nm centered at 525 nm, with two Schott BG-18 filters installed to block the red energy above 700 nm.

The probe mounting configuration is

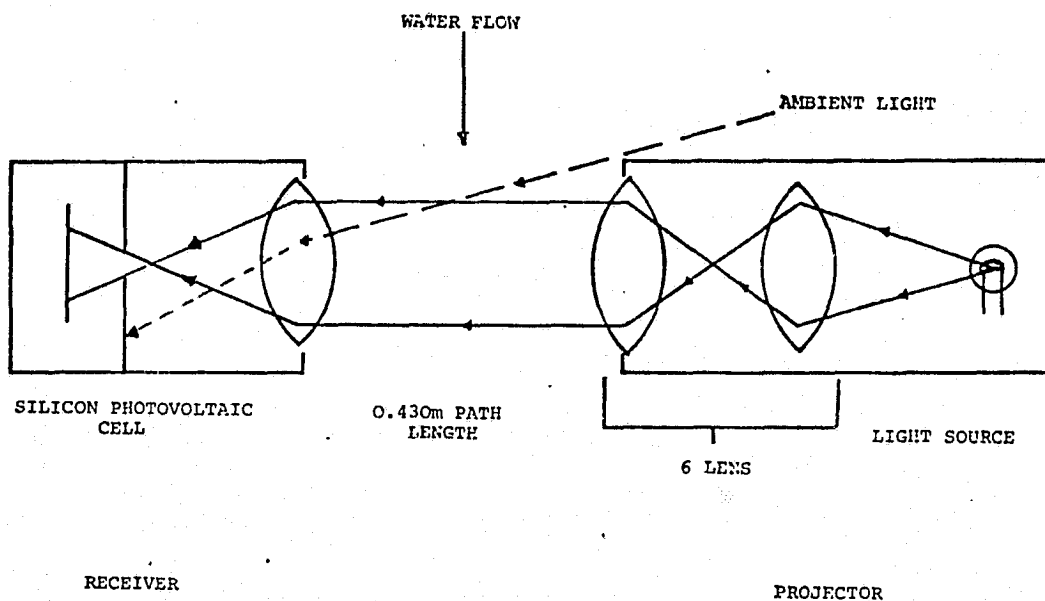

Fig. 2. Optical construction of the transmissometer probe. Ambient light is occulted by the field stop.

shown in Fig. 1B and C. The RV *Linwood Holton*, a 20-m steel hull with a mean draft of 1.68 m, is used as the platform. Two mounting holes are cut in the keel so that with the instrument mounted the beam will be 1.4 m below the mean waterline of the vessel when fully loaded. At either end of the transmissometer stainless steel stabilizing cables 6 mm in diameter are attached with steel U-bolts to eye plates welded to the hull about 1.3 m aft of the instrument. The mounting bracket itself is of steel, and all joints are welded so that the 52-kg transmissometer probe is held firmly. The transmissometer probe is hoisted over the bow in calm water. Two SCUBA divers swim the probe under the vessel to the keel mounting position while it is still being supported by cables attached to the deck hoisting rig and secure it with two mounting bolts and two stabilizing cables with turnbuckles; this takes 15 min, as does removal. No instrument distortion during ship movement has been observed with this arrangement in more than 10 field runs at speeds up to 18 km hr<sup>-1</sup> for periods not less than 4.5 hr. Optimum running speed is from 11–14 km hr<sup>-1</sup>

due to vibration of the power cable against the hull above water. Tension is maintained on this cable during operation. Sea states up to code 4 (wave height maximum of 2.44 m) have posed no instrumentation problems. During vessel operation the keel angles, with the bow positioned slightly higher in the water than the stern, so that the probe actually records transmittance at a mean depth of 1.2 m below the water surface and is thrust forward of the hull region where entrained air and foam might cause interference. Water movement through and around the probe during operation does not effect the transmission record for tested speeds up to 18 km hr<sup>-1</sup>, and the probe at no time leaves the water as the vessel pitches and rolls except in heavy seas.

The transmittance is recorded on a modified Moseley model 80A-2 strip chart recorder with an automatic balancing circuit that replaces the conventional manual read-out of the probe. The circuitry, including modifications for this particular system, has been reported by Bryant (1973). A crystal controlled, two pulse per second generator, when selected, produces a chart speed of

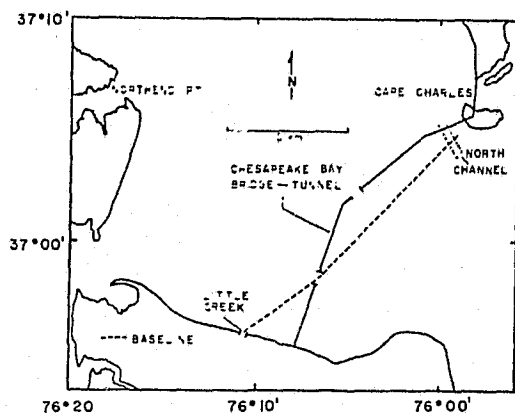

Fig. 3. Chesapeake Bay mouth with the baseline location used to generate the transmittance profiles shown in Fig. 4.

1.270  $\text{cm min}^{-1}$  within 0.1%. The chart drive velocity is therefore independent of powerline frequency, which on a small vessel is not necessarily well regulated. By recording an accurately time-referenced transmittance and coupling it with known ship speeds and navigational checks, precisely located turbidity baselines can be established.

Figure 3 shows the area used to generate two representative transmittance profiles shown in Fig. 4. The baseline totals more than 24 km and is traversed repeatedly every 18 days in less than 2 hr. After many repeated runs during different tide cycles and under sharply different weather conditions specific peaks and depressions begin to recur consistently in the turbidity record. An example of this is the two bracketed depressions shown in Fig. 4, which have reappeared consistently at this point in the Little Creek to Cape Charles record. Examination of the area reveals that the North Channel (*see Fig. 3*) coincides with the surface turbidity depression. Suspended load values were also obtained along the baseline during each profile (Freitag et al. 1974); these were as high as  $72 \text{ mg liter}^{-1}$  in the North Channel area on 13 February 1973, at least four times greater than load concentrations for the 26 January 1973 profile. Figure 4 clearly shows the marked

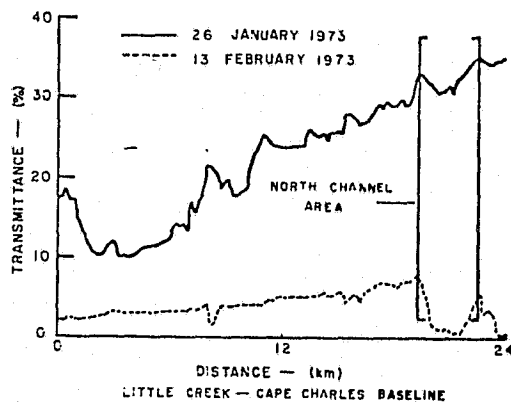

Fig. 4. Transmittance profiles generated across the mouth of Chesapeake Bay on two selected days.

difference in transmittance levels for the two days, showing that transmittance levels in a profile are indicative of actual suspended load concentration in the surface layer. Multiple turbidity runs made over a long period add additional information by taking into account variables such as tidal, weather, and stream-discharge fluctuations. Correlation of transmittance records over such an interval provides an efficient method for determining suspended load movement at the surface and relative load quantities.

Walter W. Berg, Jr.  
Peter Fleischer  
Gary R. Freitag

Institute of Oceanography  
Old Dominion University  
Norfolk, Virginia 23508

Emmett L. Bryant

NASA Langley Research Center  
Hampton, Virginia 23365

#### References

- BRYANT, E. L. 1973. Automatic recorder for a turbidity measurement probe. Langley Working Pap. 1097, NASA/Langley Res. Center, Hampton, Va. 14 p.
- DRAKE, D. E. 1972. Distribution and transport of suspended matter, Santa Barbara Channel, California. Ph.D. thesis, Univ. South. Calif., Los Angeles. 358 p.
- FREITAG, G. R., W. W. BERG, JR., AND P.

FLEISCHER. 1974. Suspended matter concentrations and turbidity in lower Chesapeake Bay: Influence of environmental factors. (Abstr.) Geol. Soc. Am. Southeast. Sect. 23rd Annu. Meeting 6: 355-356.

LUDWICK, J. C., AND J. R. MELCHOR. 1972. Sur-

face water turbidity in the entrance to Chesapeake Bay, Virginia. Inst. Oceanogr. Old Dominion Univ. Tech. Rep. 5. 67 p.

*Submitted: 21 December 1973*

*Accepted: 24 September 1974*

APPENDIX F  
ATTENUATION-COEFFICIENT PROFILES  
SEE FIGURE 1 AND TEXT  
FOR EXPLANATION  
OF BASELINE LOCATIONS

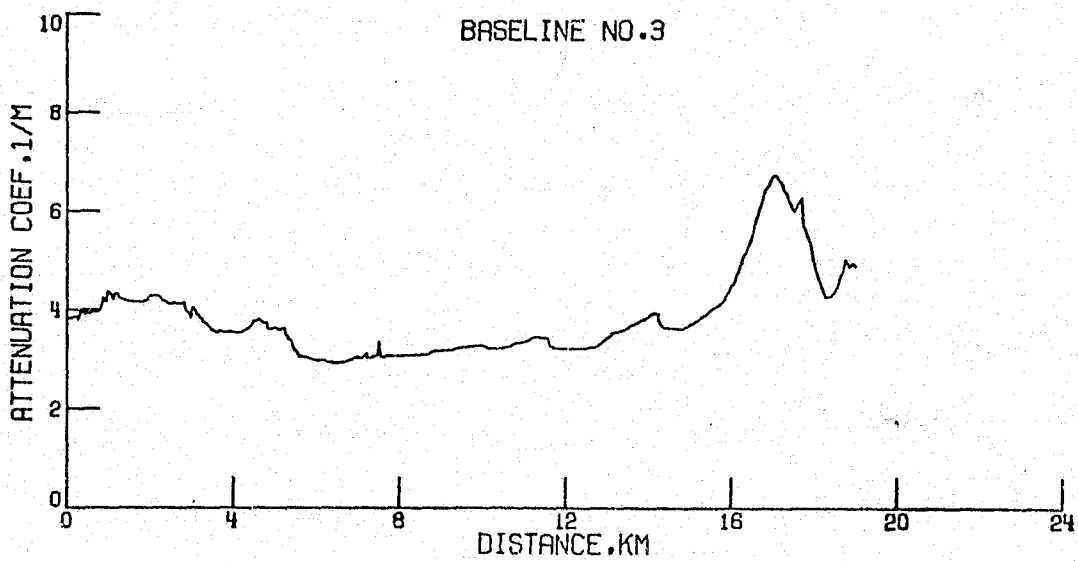
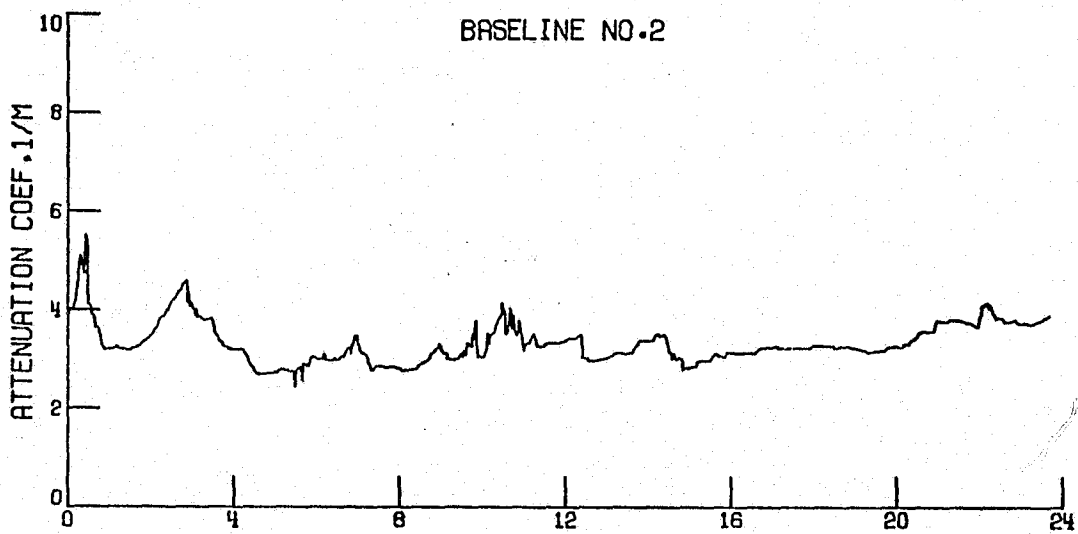
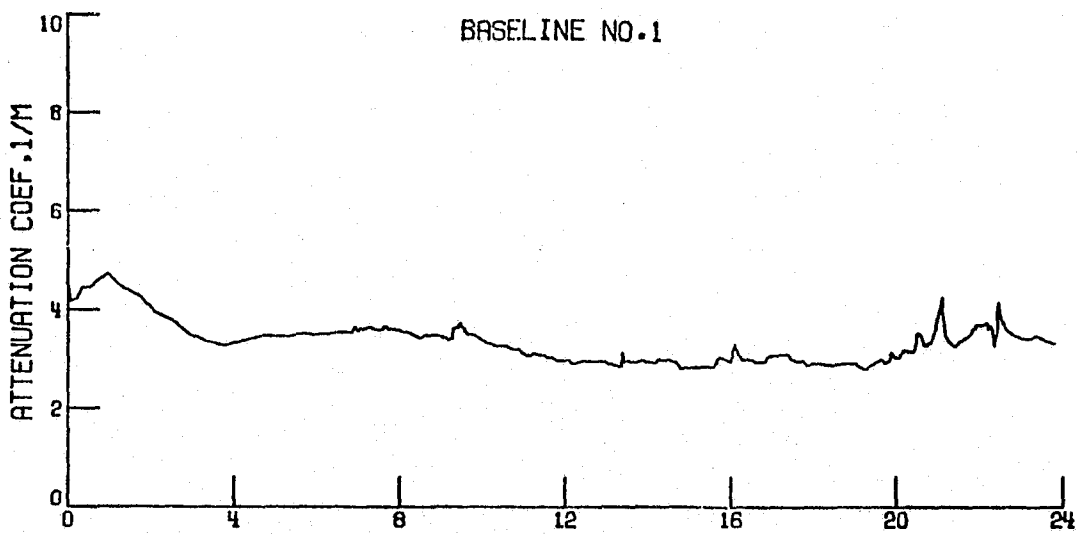



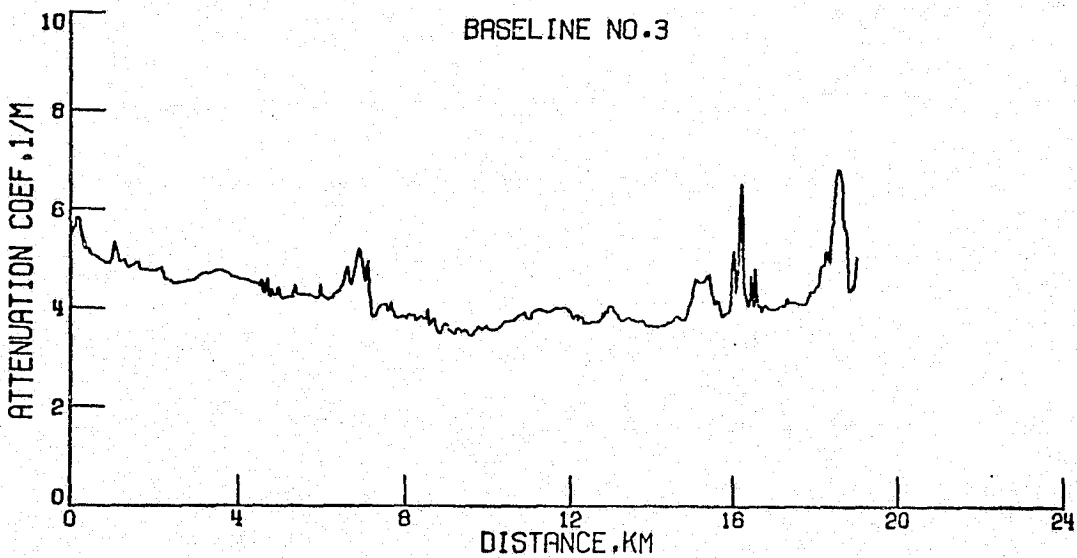
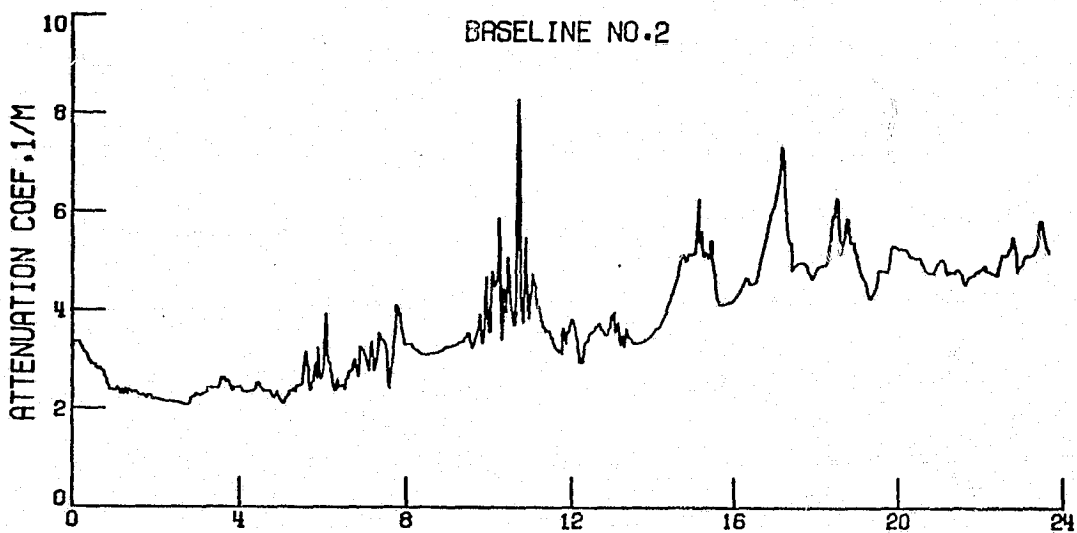
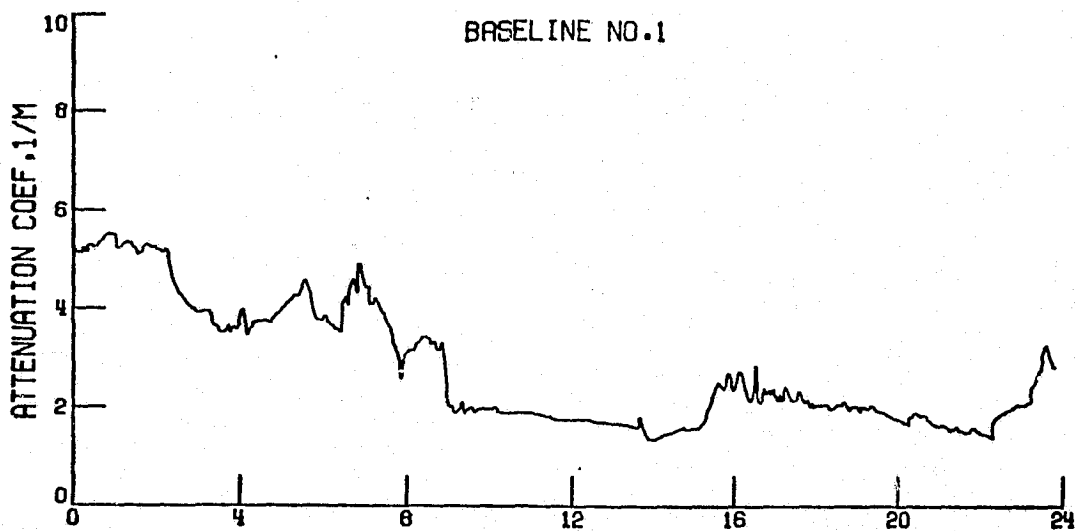

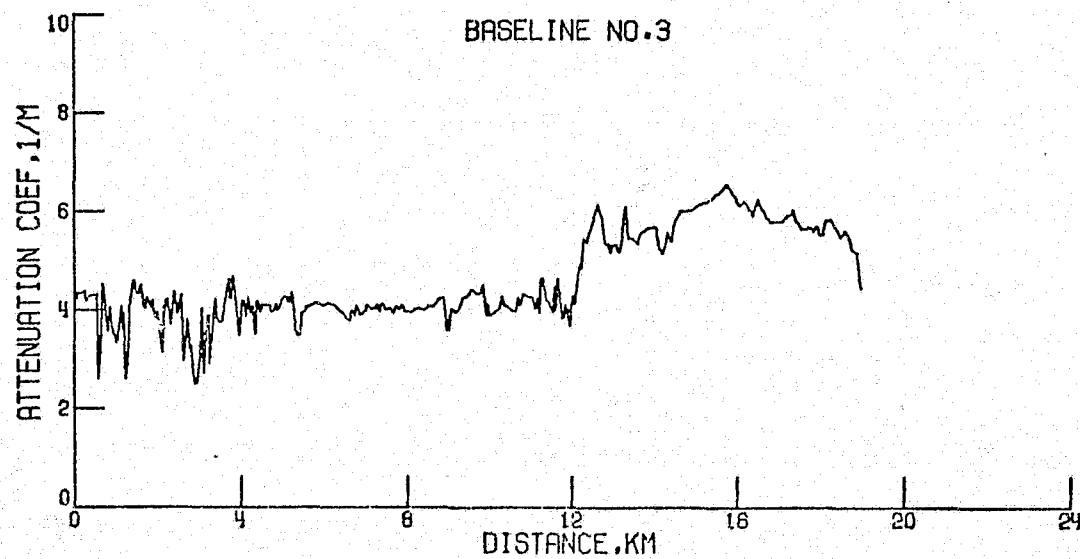
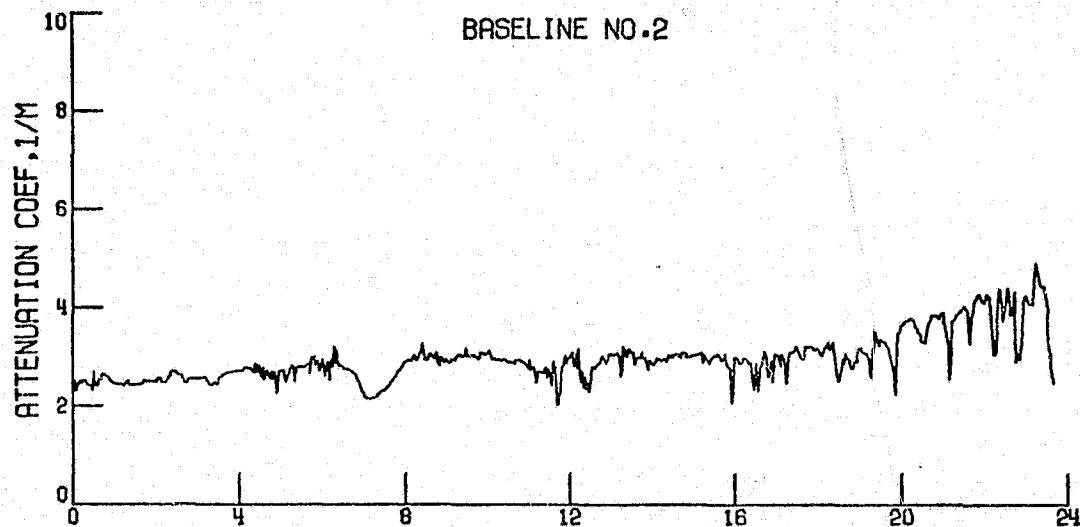
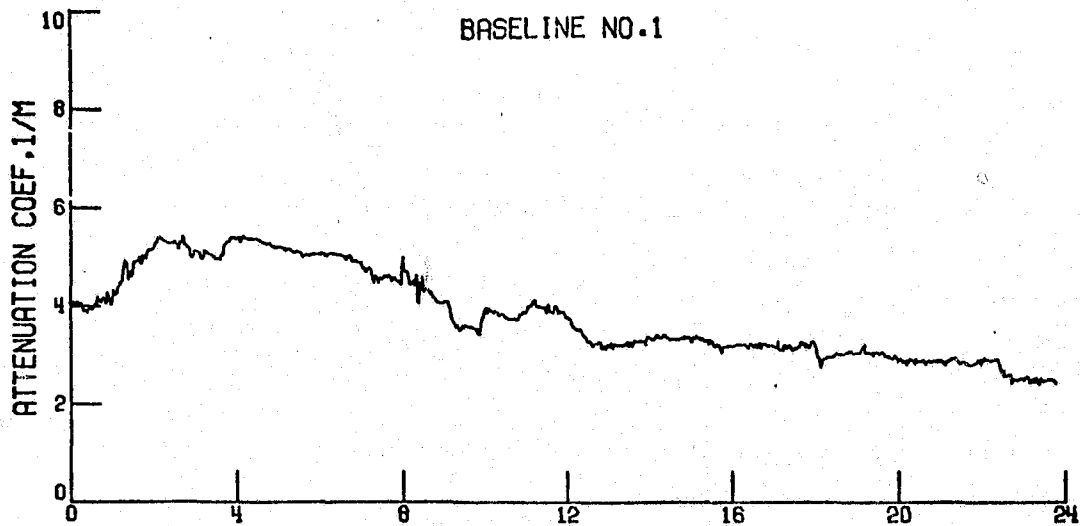

FEB 13.1973

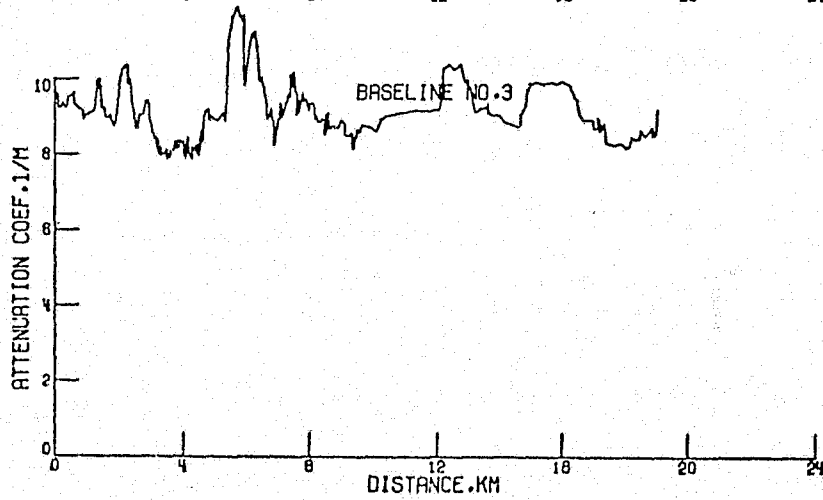
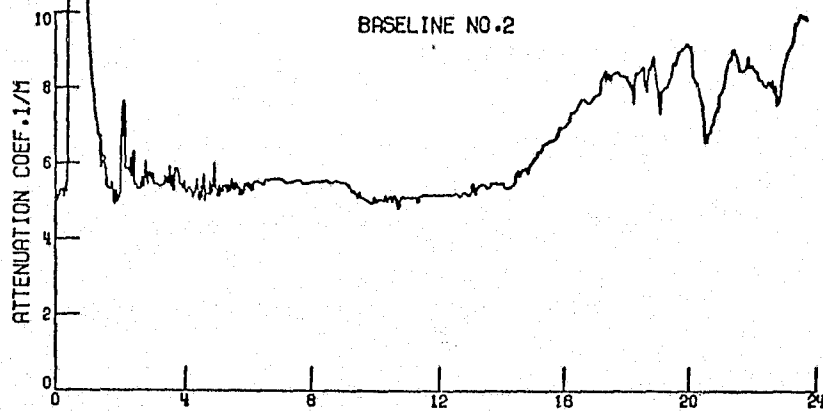
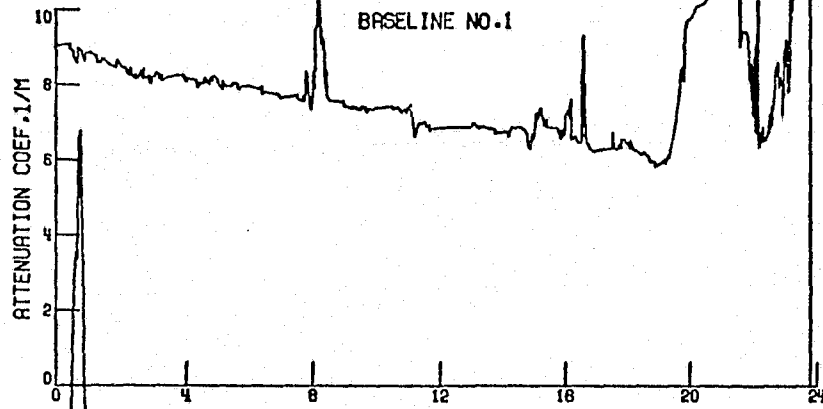

MARCH 3, 1973

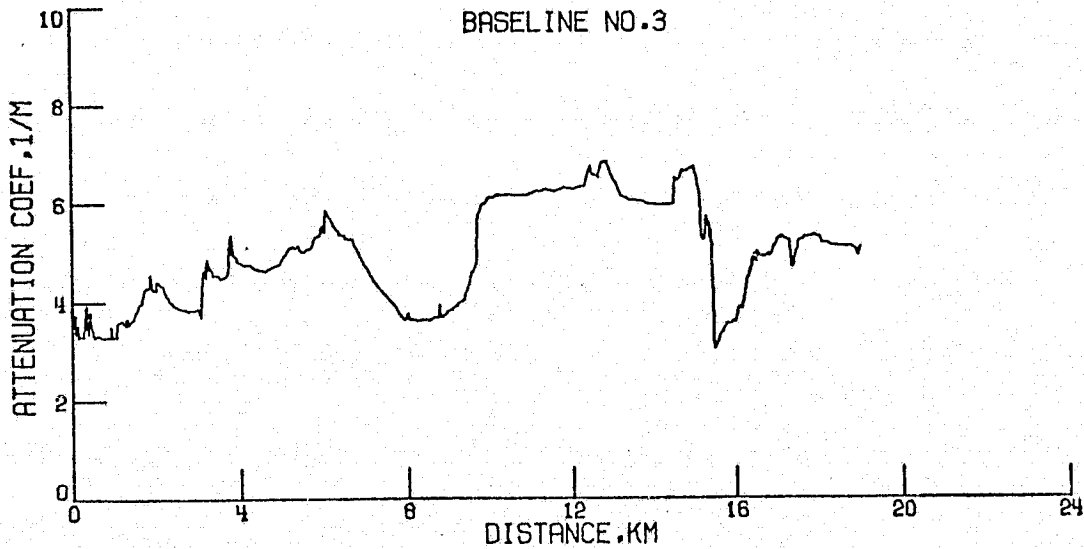
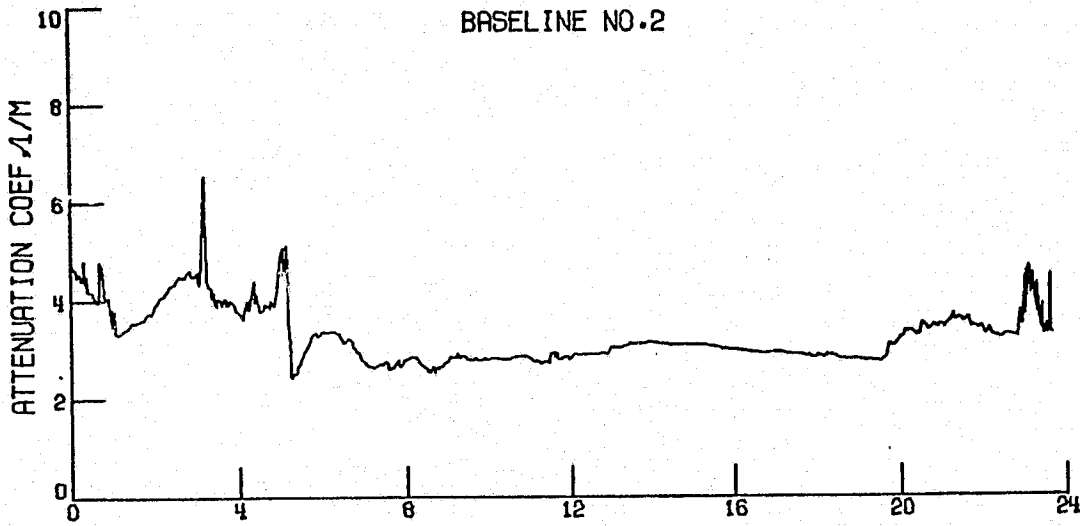
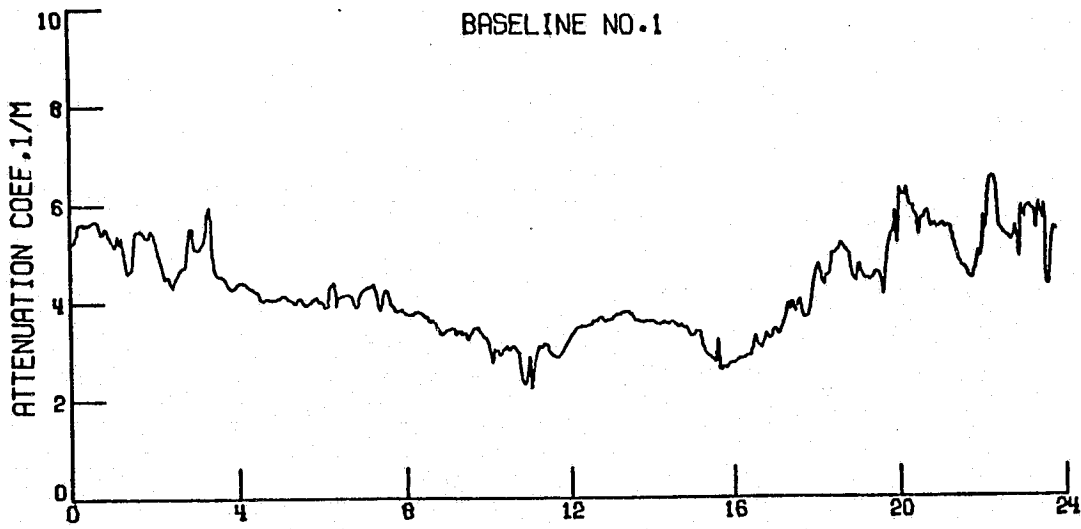

APRIL 8, 1973

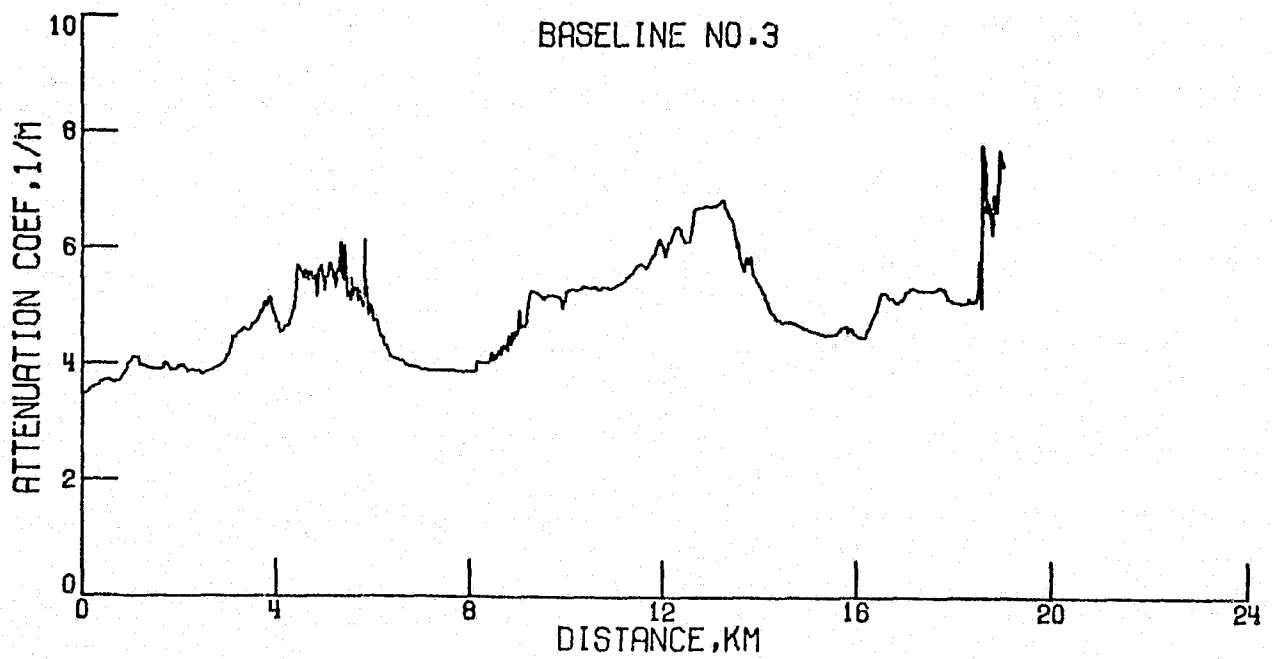

MAY 14, 1973

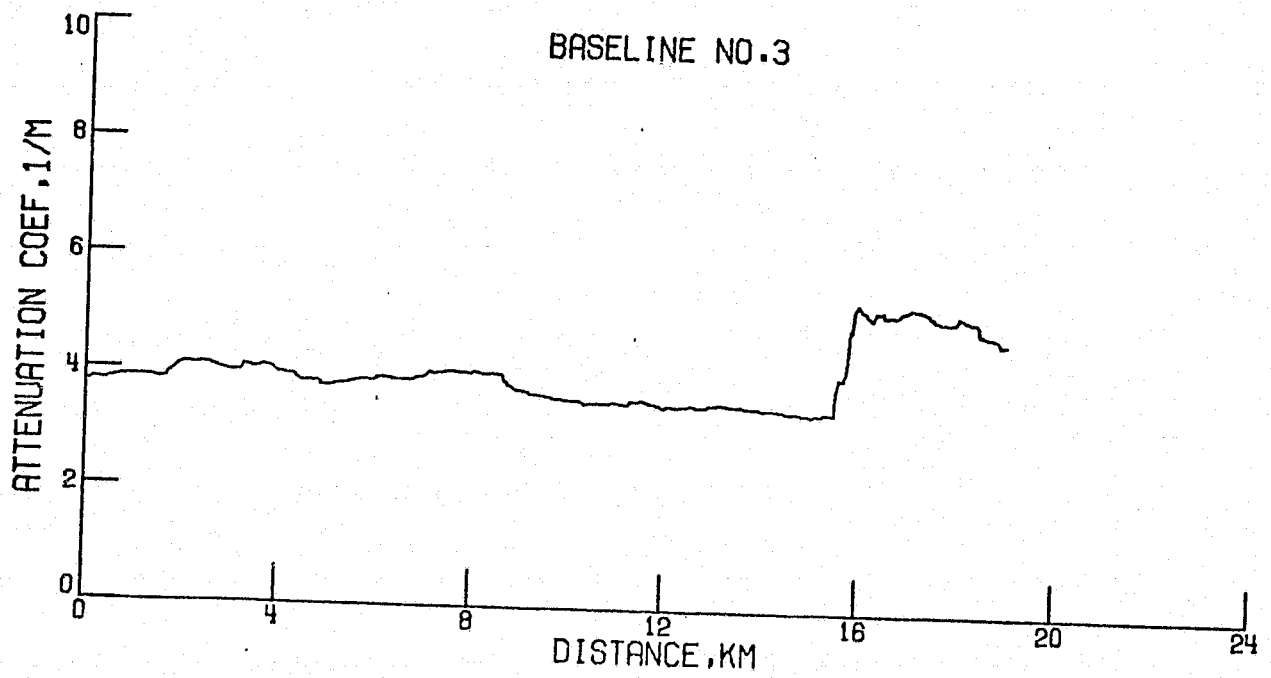

JUNE 1.1973

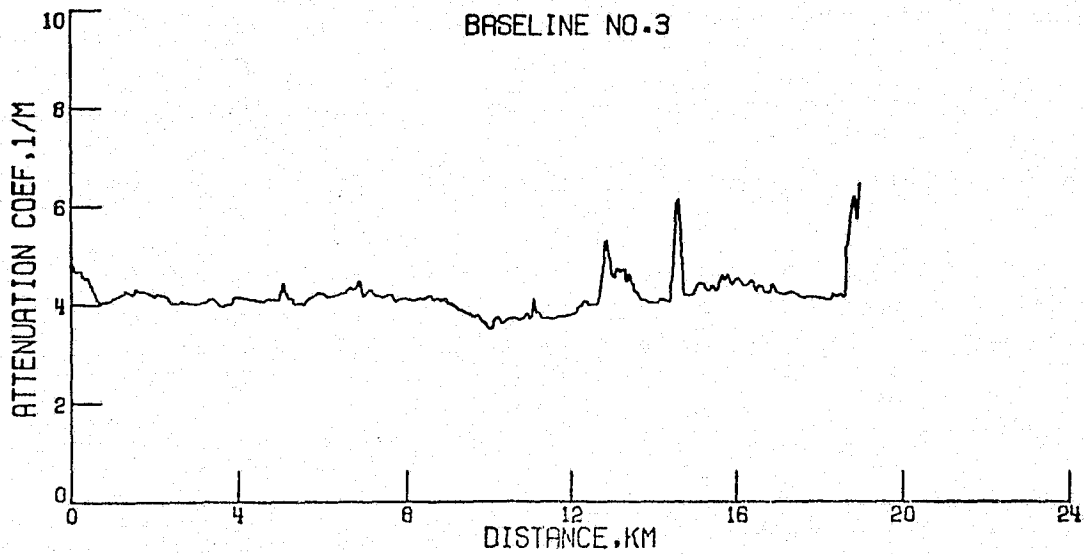
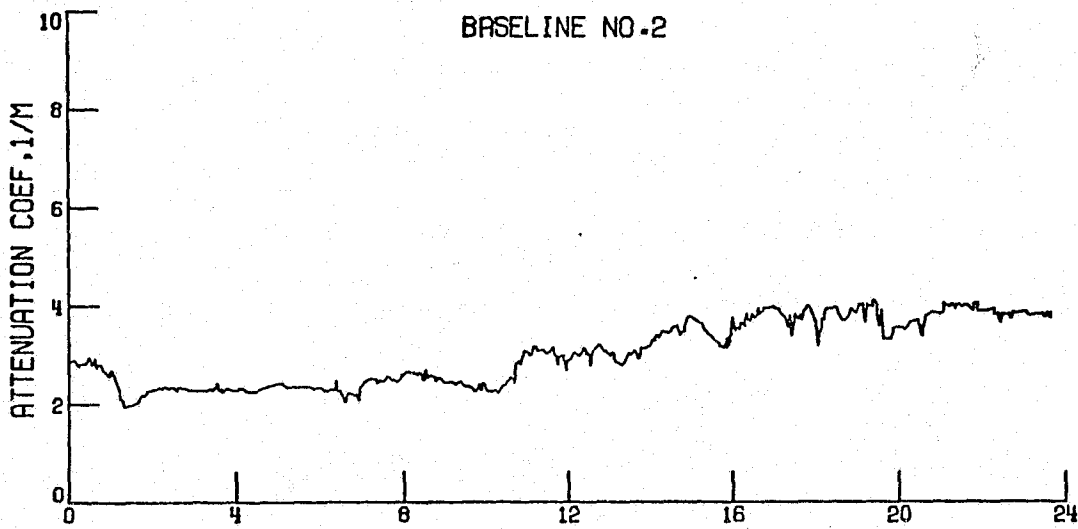
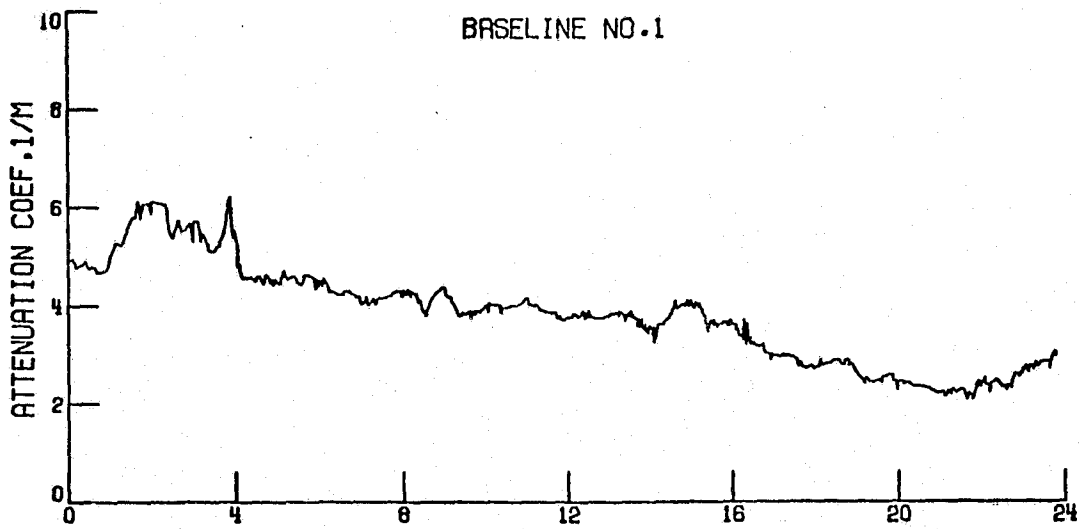

JUNE 19.1973

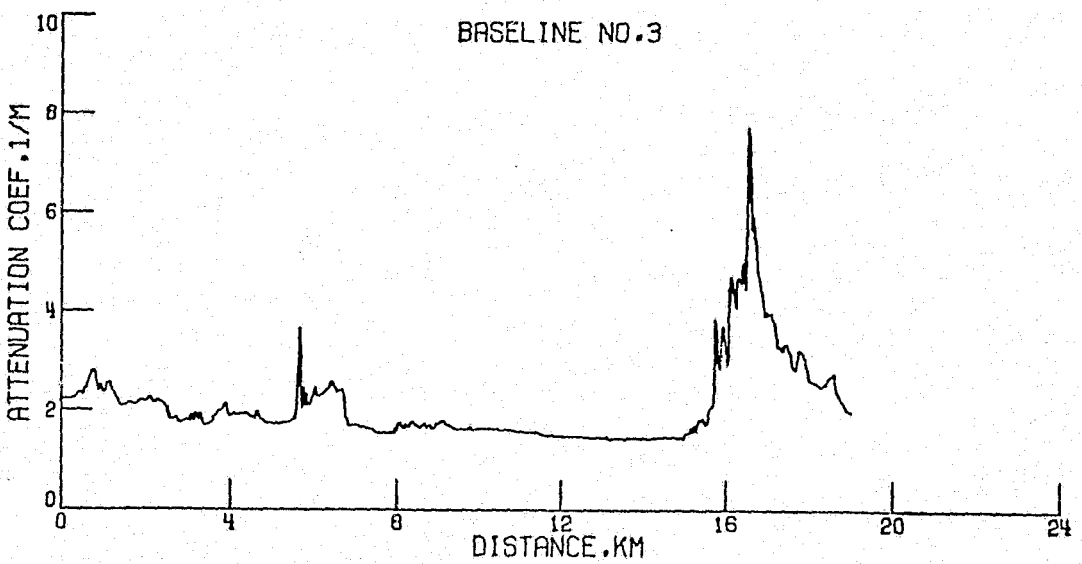
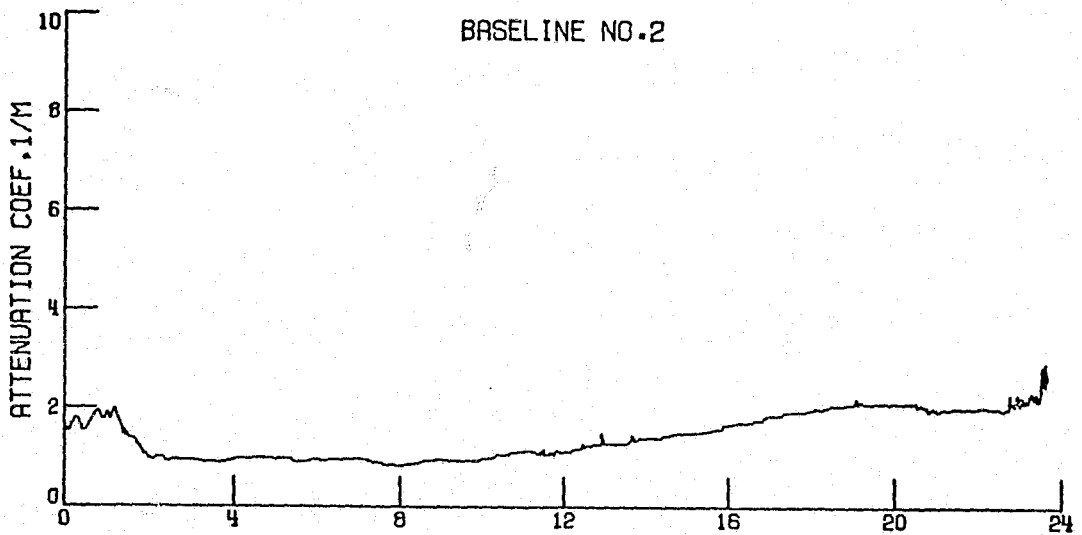
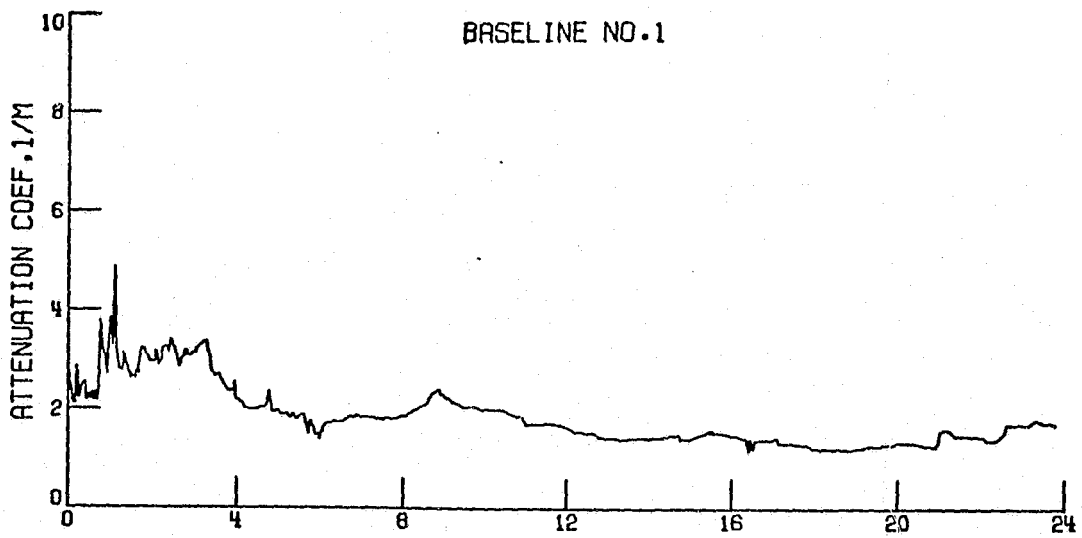



JULY 7, 1973

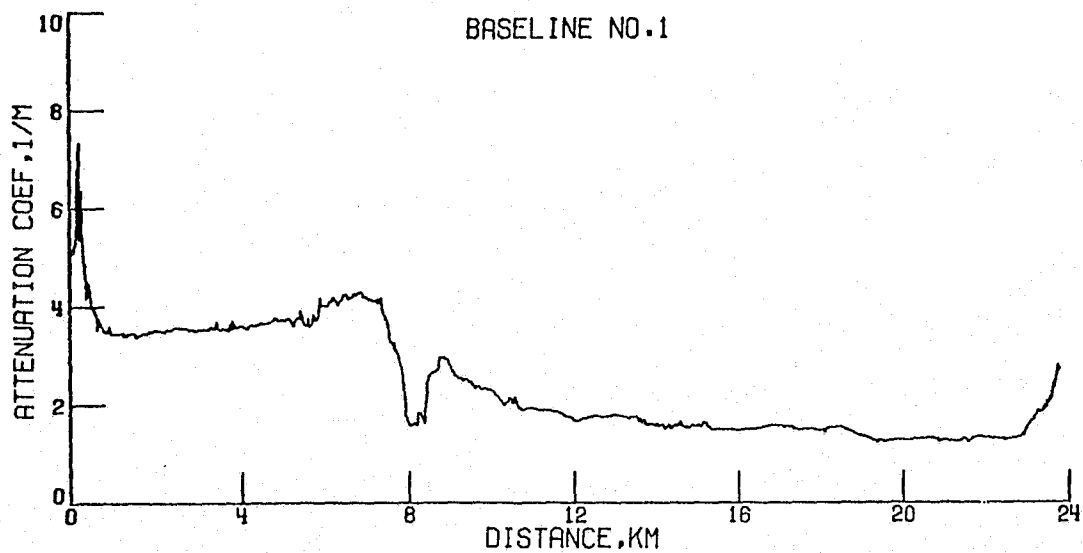

JULY 7, 1973

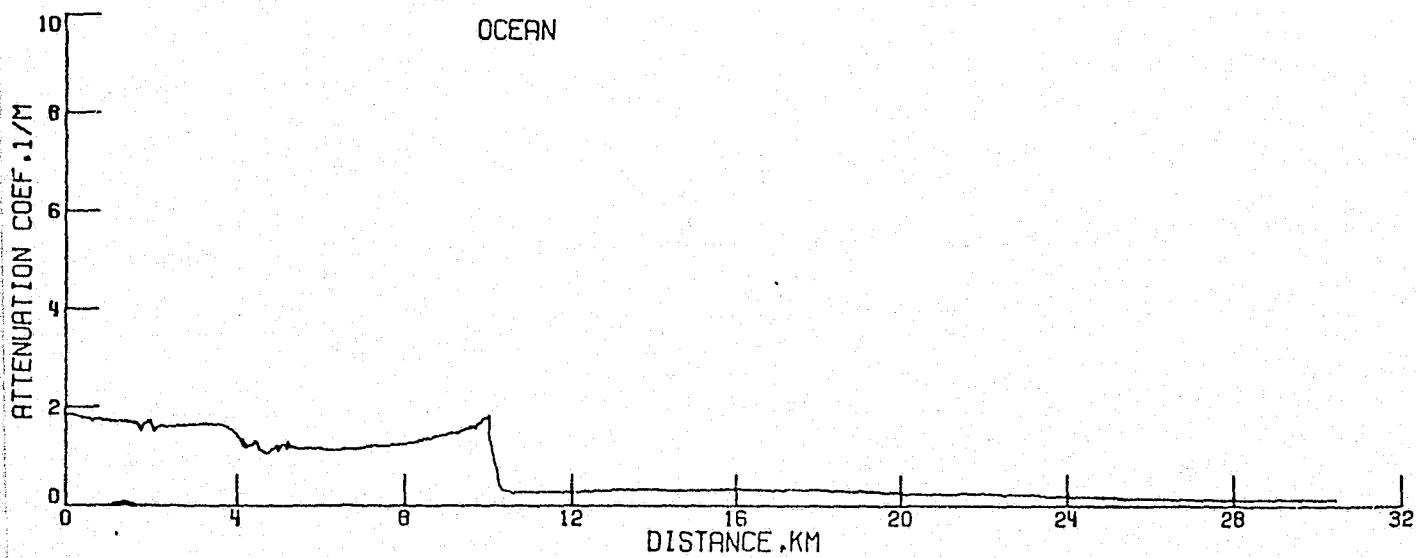

JULY 25, 1973

PART 1

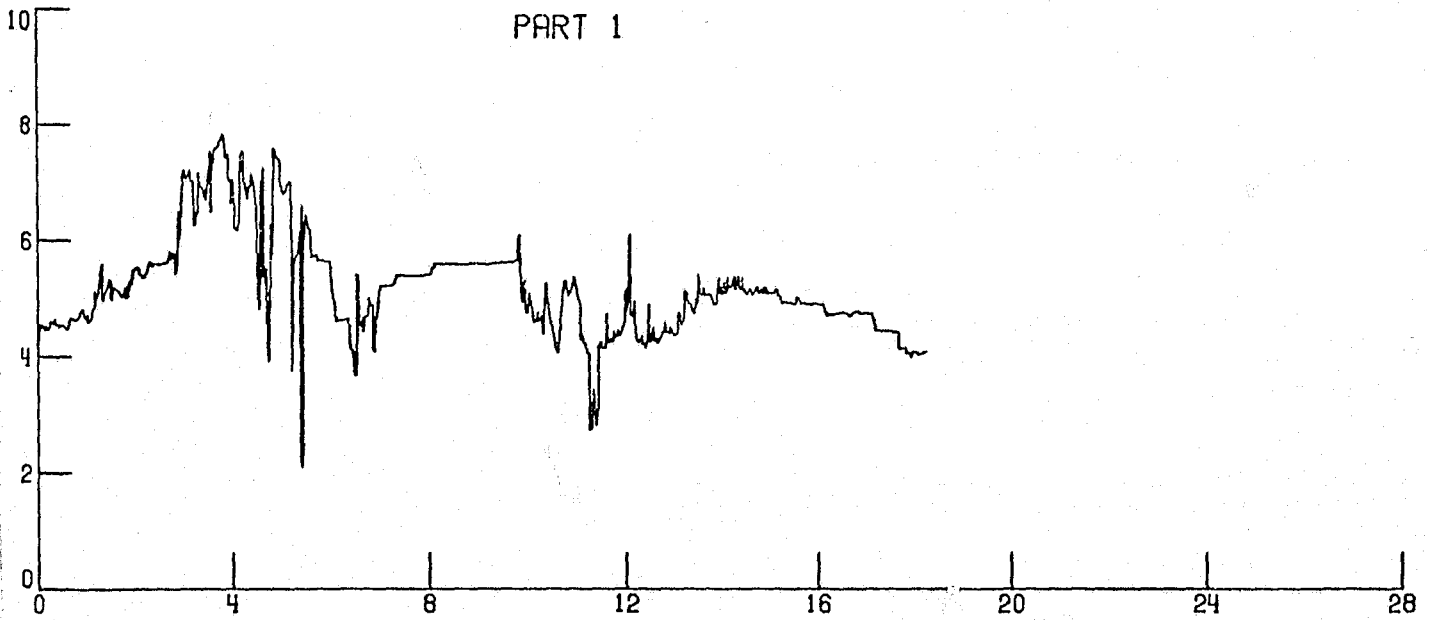

PART 2

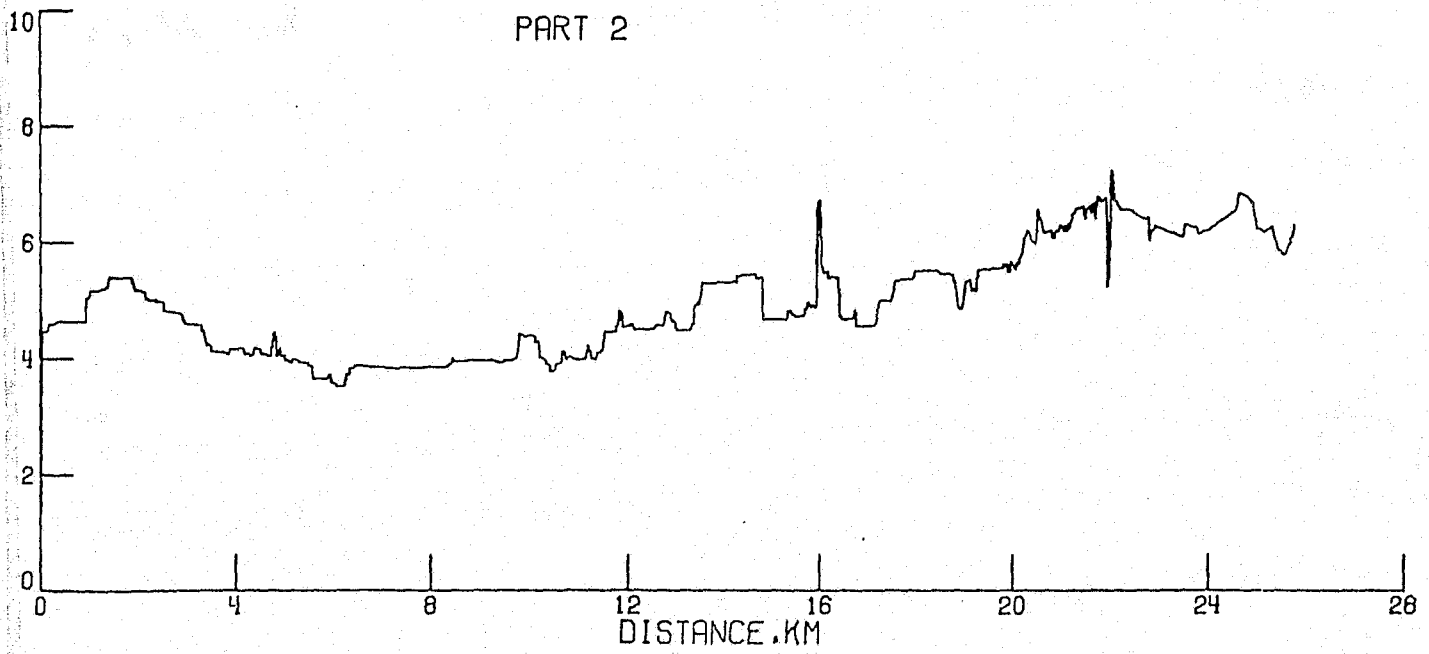

SEPT 17, 1973

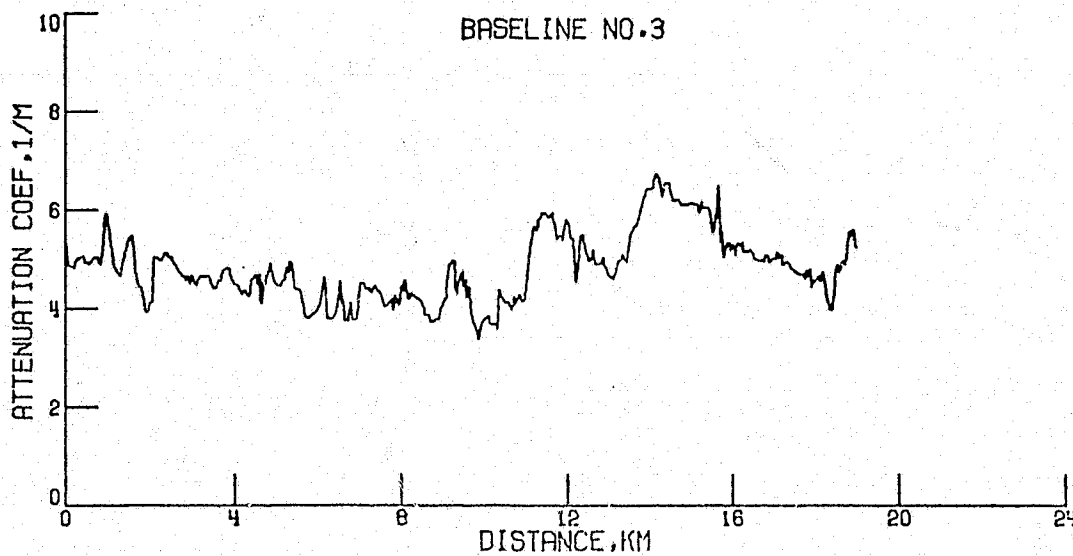
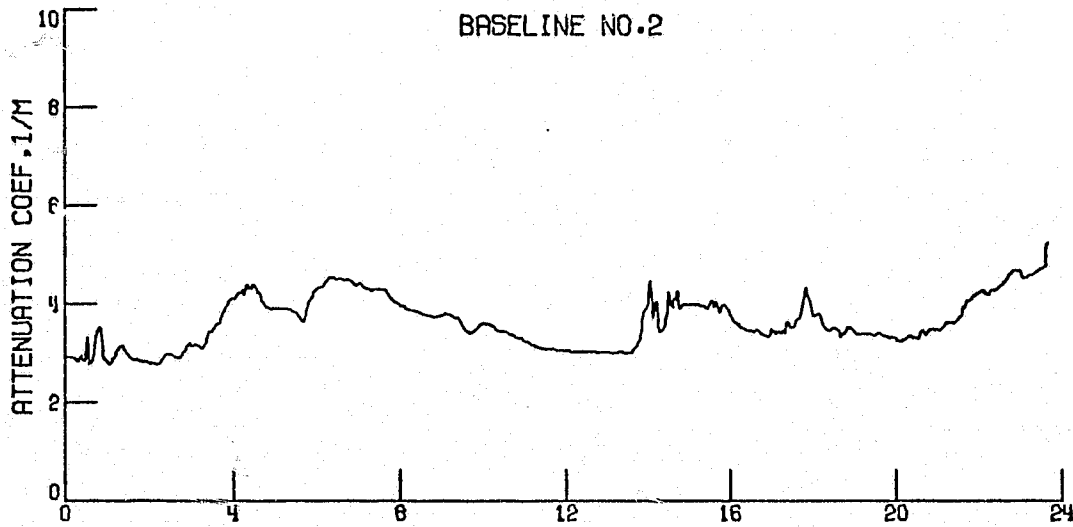
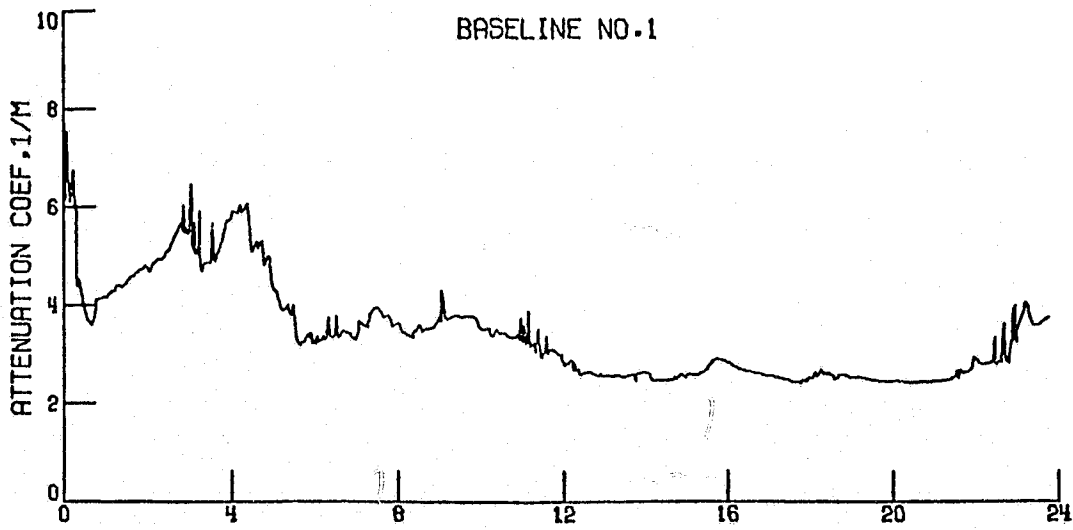

OCT 5, 1973

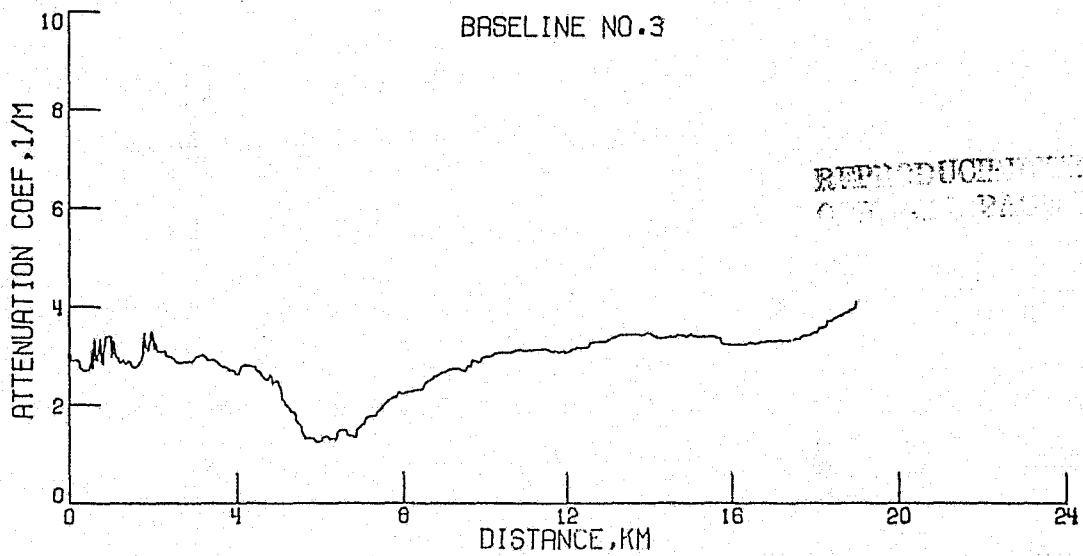
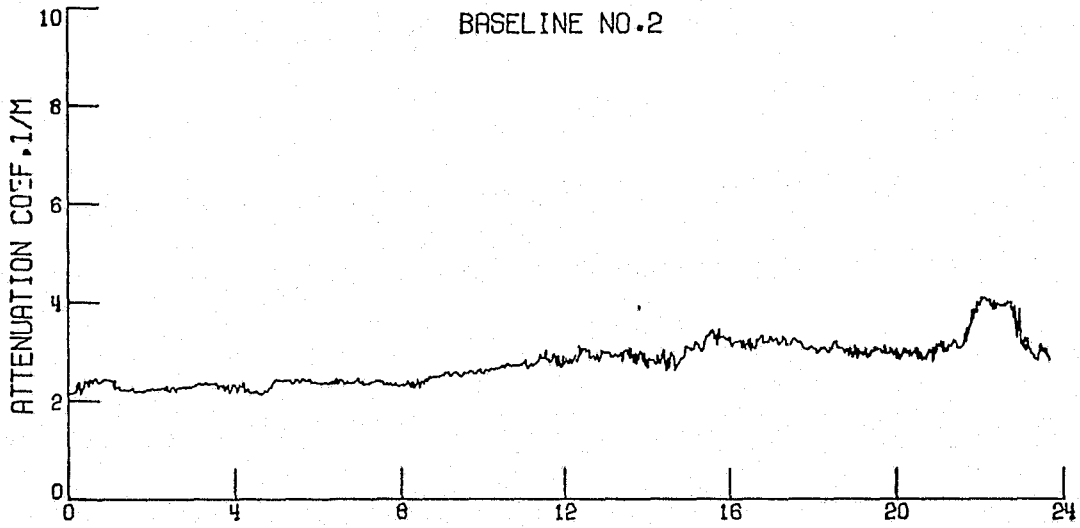
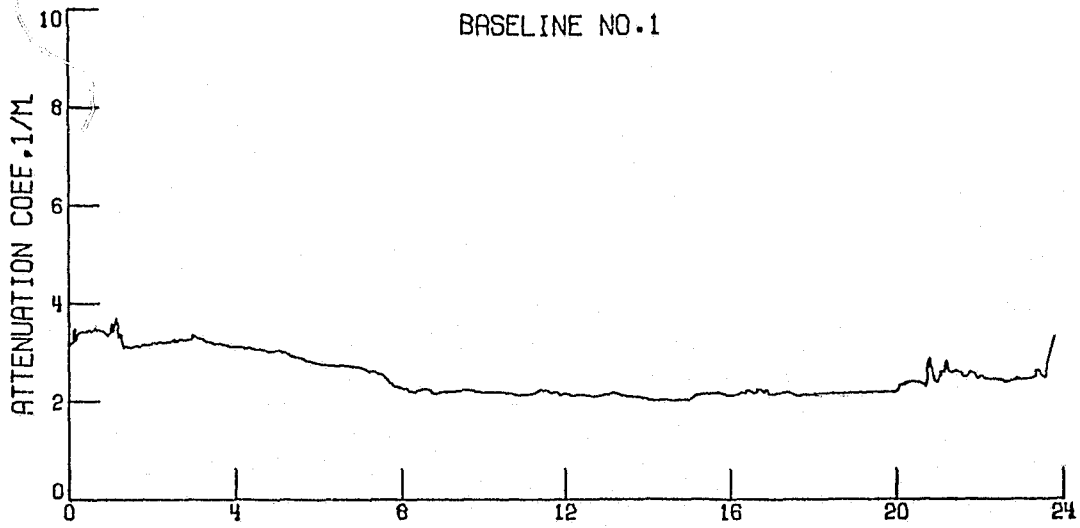

REPRODUCTION OF FILM  
OF THE BASELINE NO. 3

OCT 23, 1973

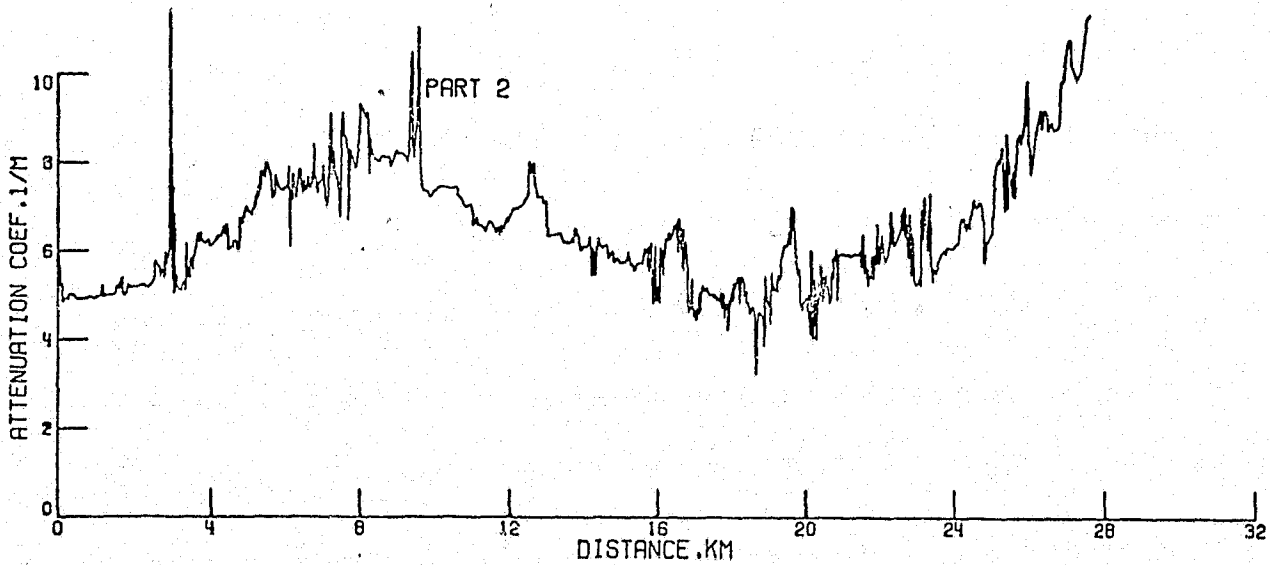
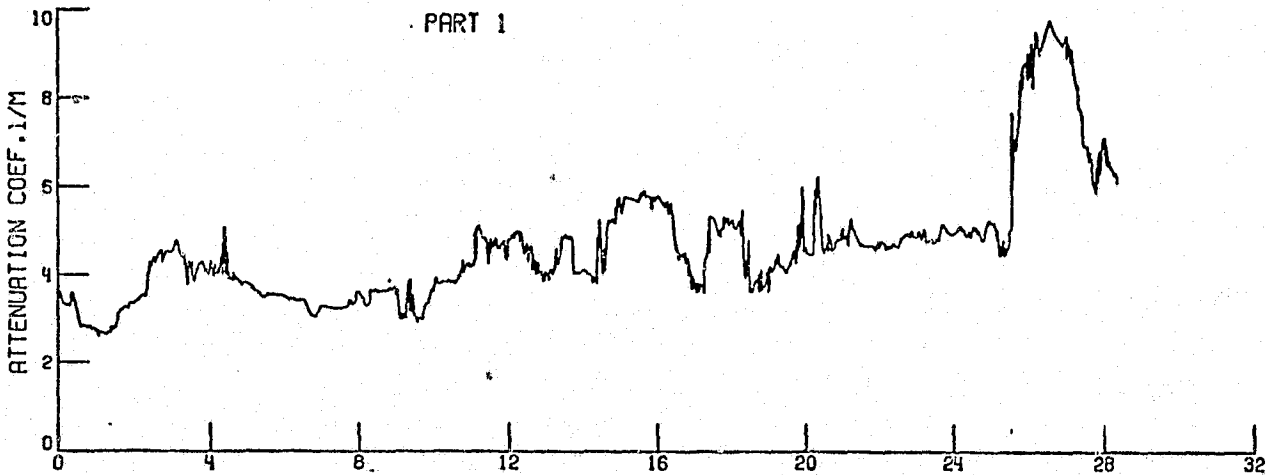

APPENDIX G  
BATHYMETRIC PROFILES  
SEE FIGURE 1 AND TEXT  
FOR EXPLANATION  
OF BASELINE LOCATIONS

FEB 13, 1973

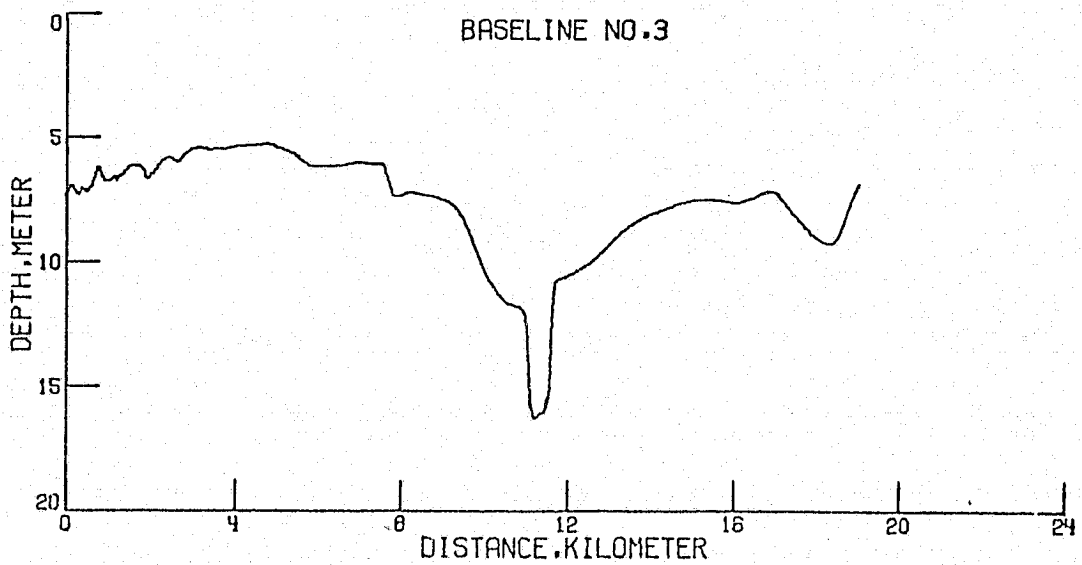
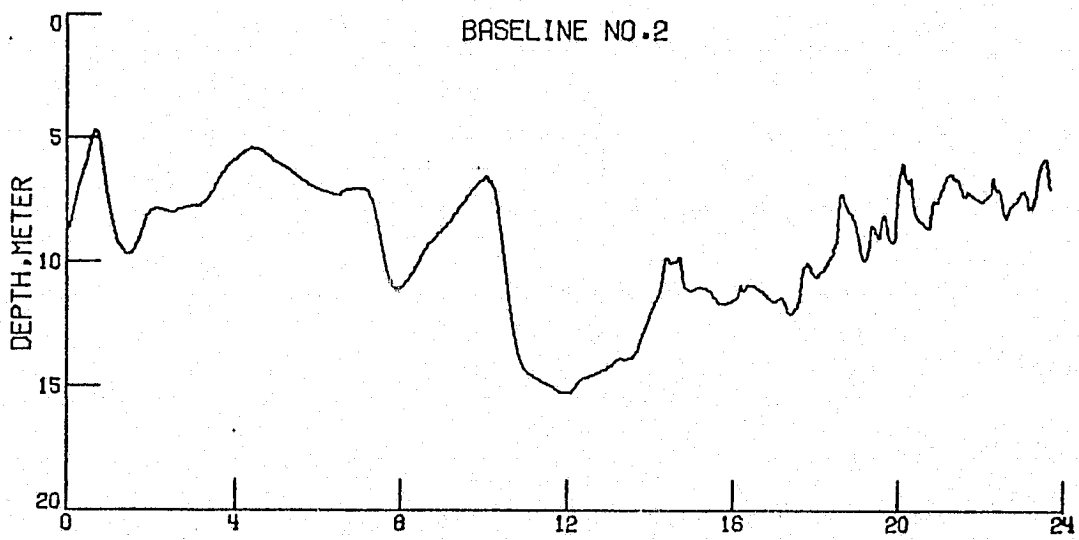
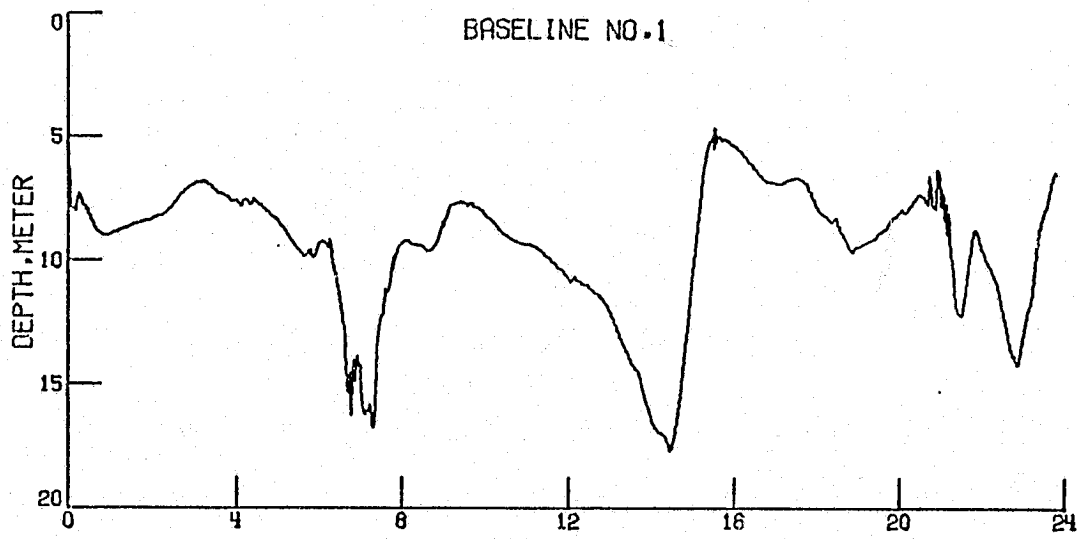

SEPT 17, 1973

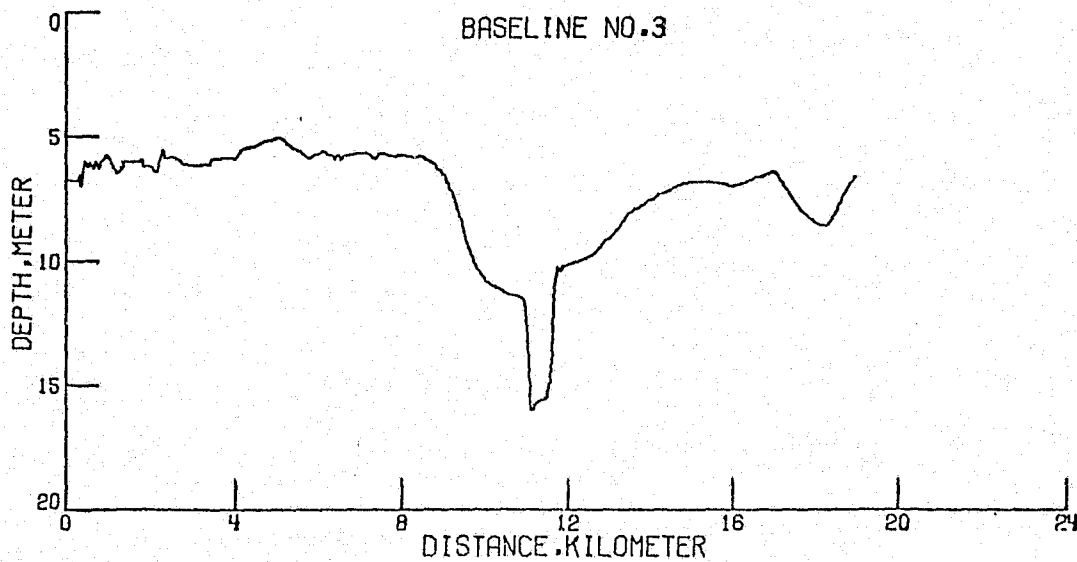
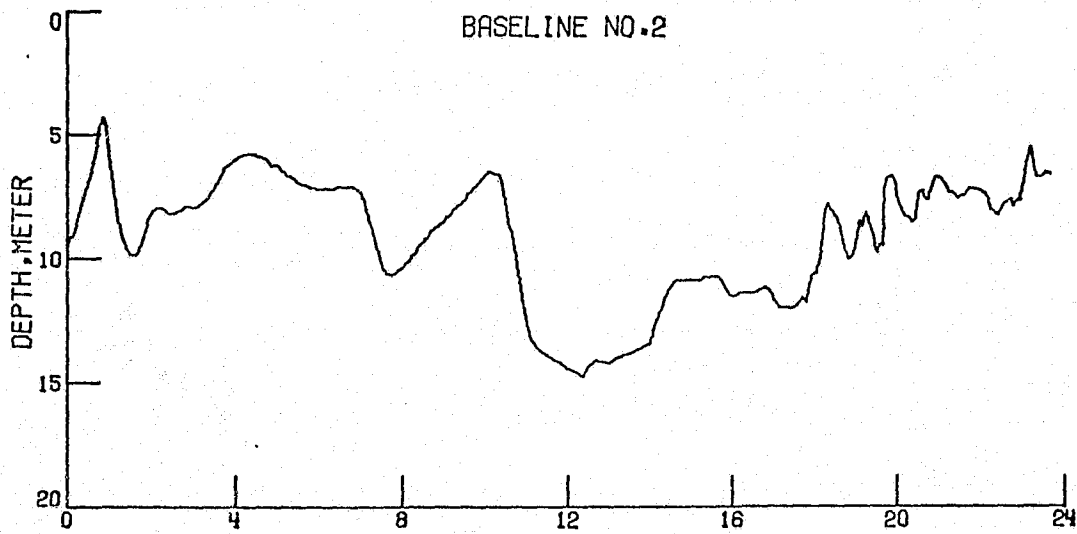
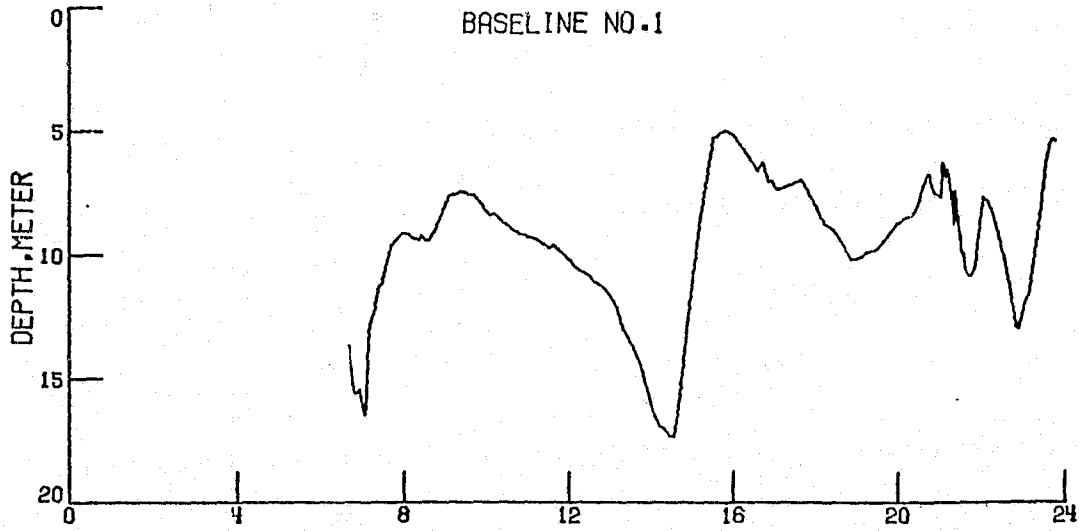



APPENDIX H  
WATER-SAMPLE PARAMETERS,  
SAMPLES COLLECTED FROM  
R/V LINWOOD HOLTON

## SHIP DATA

Date	Station No.	Time EST	%T	Temp. °C	Sal. ‰	pH	Depth ft.	Susp. Sed. mg/l	
1-26-73	1	0921	17.0	6.00	--	--	42	3.55	
	2	1015	32.8	5.00	--	--	29	2.89	
	3	1100	35.5	5.10	--	--	37	2.11	
	4	1145	28.6	5.50	--	--	27	1.80	
	5	1215	24.7	5.10	--	--	35	2.30	
	6	1245	17.0	5.20	--	--	23	3.02	
	7	1334	18.5	5.70	--	--	55	4.70	
2-13-73	1	0947	3.2	2.80	--	7.76	35.0	8.01	
	2	1045	7.0	3.10	--	7.80	29.5	5.81	
	3	1215	11.7	3.70	--	7.85	28.0	5.27	
	4	1300	11.0	4.25	--	7.40	21.0	5.27	
	6	1415	1.7	3.02	--	7.25	23.5	12.48	
	8	1527	2.3	3.35	--	7.15	53.0	11.54	
	9	1150	0.0	--	--	--	--	72.78	
	3- 3-73	1	0921	20.0	5.14	15.2	--	51	2.05
		2	1015	13.0	4.79	18.4	--	26.0	0.96
3		1115	12.8	5.79	27.7	--	20.0	6.92	
4		1210	30.5	4.89	14.3	--	36.0	1.69	
5		1245	28.9	5.19	14.2	--	34.0	2.75	
6		1336	20.5	5.40	14.8	--	14.7	1.25	
7		1422	6.9	5.85	13.5	--	32.0	--	
4- 8-73	2	1310	50.0	--	24.46	--	36	4.81	
	3	1230	39.0	9.82	22.87	--	18	4.20	
	4	1145	29.0	9.82	19.35	--	27	4.33	
	5	1100	18.9	9.82	22.87	--	18	4.20	
	6	0948	18.0	10.82	16.41	--	24.0	8.30	
	7	0856	10.8	11.09	14.05	--	16.5	5.72	
	6- 1-73	1	1448	16.0	20.57	17.50	--	34.0	3.43
2		1355	36.0	19.50	23.07	--	26.0	4.63	
3		1050	28.9	19.48	28.32	--	20.0	3.94	
4		1009	27.5	19.43	20.60	--	44.2	3.54	
5		0945	18.5	--	17.43	--	25.0	2.24	
6		0910	16.8	19.90	19.31	--	14.7	6.73	
7		0830	20.0	19.55	18.91	--	32.0	6.45	
6-19-73	1	1322	44.5	22.00	22.82	--	33.0	2.29	
	2	1230	56.0	19.25	30.02	--	26.0	2.96	
	3	1137	(In North Channel -				depth)	5.22	
	3	1137	51.0	20.02	29.12	--	20.0	2.32	
	5	1025	47.5	21.04	22.20	--	34.0	1.63	
	6	0935	38.8	22.40	20.82	--	13.5	5.47	
	7	0905	48.3	22.25	21.07	--	18.2	2.66	
7- 7-73	10	0855	56.9	24.58	25.10	--	34	1.40	
	11	0910	45.0	23.65	29.30	--	25.5	1.45	
	12	0925	60.5	23.22	31.60	--	15.0	3.66	
	13	0940	55.0	23.58	31.00	--	26.5	2.78	

(continued)

## SHIP DATA (concluded)

Date	Station No.	Time EST	%T	Temp. °C	Sal. ‰	pH	Depth ft.	Susp. Sed. mg/l
	14	0955	87.8	24.38	29.60	---	32.5	1.01
	15	1011	88.0	25.25	28.84	---	37.0	0.77
	16	1025	91.2	25.60	29.64	---	41.5	1.16
	17	1040	94.5	25.65	30.42	---	53.0	1.01
		1055	95.5	25.50	31.25	---	55.0	---
7-25-73	A	0936	4.0	25.34	20.40	---	64.0	5.12
	B	0955	7.0	25.24	21.12	---	45.0	7.56
	C	1028	17.0	25.33	20.30	---	45.0	8.37
	D	1108	17.5	26.20	16.34	---	32.0	5.89
	E	1227	12.0	27.40	16.55	---	23.0	11.03
	F	1321	7.0	28.35	8.48	---	24.5	12.60
9-17-73	1	0815	23.0	23.30	---	---	34.0	4.12
	2	0923	33.5	24.00	---	---	24.5	2.63
	3	1005	28.0	24.00	---	---	31	4.61
	4	1047	23.5	24.25	---	---	28.0	11.04
	5	1115	19.5	24.40	---	---	37	4.42
	6	1147	12.0	24.20	---	---	17.5	5.53
	7	1233	8.5	24.10	---	---	49	7.45
12- 3-72	1	1331	20.0	---	---	---	22.4	11.52
	2	1308	22.0	---	---	---	35.0	8.0
	3	1207	27.5	---	---	---	26.0	5.40
	4	1135	18	---	---	---	20.0	12.65
	5	1052	23	---	---	---	18.0	9.15
	6	1022	24.8	---	---	---	34.0	6.41
	7	0946	16.9	---	---	---	13.5	5.49
	8	0906	24	---	---	---	32.0	8.57
1-26-73	G1	---	---	---	---	---	---	4.09
	G2	---	---	---	---	---	---	4.29
	G3	---	---	---	---	---	---	5.34
5-14-73	6	1040	19.0	18.69	29.77	---	20.0	4.54
	7	1000	21.3	18.05	29.40	---	16.0	3.01
10- 5-73	1	0745	25.0	23.0	---	---	21.5	12.1
	2	0851	36.0	23.0	---	---	23.0	---
	3	1315	39.5	24.0	---	---	20.0	2.19
	4	1358	32.0	24.1	18.5	---	23.0	0.78
	5	1426	24.5	24.5	19.0	---	34.0	---
	6	1509	26.0	23.9	15.7	---	13.0	2.92
	7	1547	26.5	23.7	---	---	45.0	---
10-23-73	A	0910	21.0	17.8	---	---	79.5	5.65
	B	0932	11.0	18.0	---	---	48.5	8.19
	C	1003	13.0	18.0	---	---	48.0	3.10
	D	1042	18.5	18.0	---	---	37.5	5.72
	E	1202	6.0	18.0	---	---	31.0	20.69
	F	1251	11.0	18.7	---	---	29.5	6.36

## REFERENCES

1. Strickland, J.D.H.; and Parsons, T.R.: A Manual of Sea Water Analysis, Fisheries Research Board of Canada, Bull. No. 125, 2nd ed., 1965, p. 119.
2. Berg, W.J., Jr.; Fleischer, P.; Freitag, G.R.; Bryant, E.L.: A Continuous Turbidity Monitoring System for Coastal Surface Waters, Limnology and Oceanography, Vol. 20, 1975, pp. 137-141.
3. Bryant, E.L.: Automatic Recorder for a Turbidity Measurement Probe, NASA Langley Working Paper 1097, 1973, p. 14.
4. Yost, E.; Hollman, R.; Alexander, J.; and Nuzzi, R.: An Interdisciplinary Study of the Estuarine and Coastal Oceanography of Block Island Sound and Adjacent New York Coastal Waters, Third Earth Resources Technology Satellite-1 Symposium, NASA SP-351, Vol. 1, Sec. B, Dec. 10-14, 1973, pp. 1607-1618.
5. Bressette, Walter E.; and Lear, Donald E., Jr.: The Use of Near-Infrared Photography for Biodegradable Pollution Monitoring of Tidal Rivers, Proceedings of the American Society of Photogrammetry, Fall Convention, Part 2, Oct. 2-5, 1973, pp. 906-925.
6. Strong, Alan E.: ERTS-1 Observes Algal Blooms in Lake Erie and Utah Lake, Symposium of Significant Results Obtained From the Earth Resources Technology Satellite-1, NASA SP-327, Vol. 1, Sec. B, Mar. 5-9, 1973, pp. 1605-1612.
7. Hodara, H.: Experimental Results of Small Angle Scattering, AGARD Lecture Series No. 61, on Optics of the Sea, Aug. 1973, pp. 3.4-5.
8. Bowker, D.E.; Fleischer, P.; Gosink, T.A.; Hanna, W.J.; and Ludwick, J.C.: Transmissometry and Suspended Matter in Lower Chesapeake Bay: Correlation with ERTS Multispectral Imagery, Proceedings of the American Society of Photogrammetry, Fall Convention, Part 2, Oct. 2-5, 1973, pp. 840-847.