

NASA
TN
D-8062
v.2
c.1

NASA TECHNICAL NOTE

NASA TN D-8250

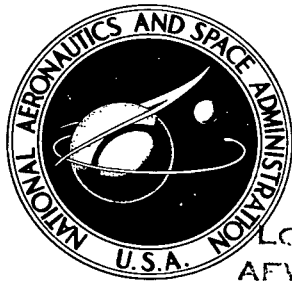

LOAN COPY: RE
AFWL TECHNICAL
KIRTLAND AFB,



EFFECTS OF LONG-CHORD ACOUSTICALLY TREATED STATOR VANES ON FAN NOISE

II - Effect of Acoustical Treatment

*James H. Dittmar, James N. Scott,
Bruce R. Leonard, and Edward G. Stakolich*

*Lewis Research Center
Cleveland, Ohio 44135*





0133791

1. Report No. NASA TN D-8250	2. Government Accession No.	3. Recipient
4. Title and Subtitle EFFECTS OF LONG-CHORD ACOUSTICALLY TREATED STATOR VANES ON FAN NOISE II - EFFECT OF ACOUSTICAL TREATMENT	5. Report Date October 1976	6. Performing Organization Code
7. Author(s) James H. Dittmar, James N. Scott, Bruce R. Leonard, and Edward G. Stakolich	8. Performing Organization Report No. E-8736	10. Work Unit No. 505-03
9. Performing Organization Name and Address Lewis Research Center National Aeronautics and Space Administration Cleveland, Ohio 44135	11. Contract or Grant No.	13. Type of Report and Period Covered Technical Note
12. Sponsoring Agency Name and Address National Aeronautics and Space Administration Washington, D.C. 20546	14. Sponsoring Agency Code	
15. Supplementary Notes		
16. Abstract A set of long-chord stator vanes was designed to replace the vanes in an existing fan stage. The long-chord stator vanes consisted of a turning section and axial extension pieces, all of which incorporated acoustic damping material. The long-chord stator vanes were tested in two lengths, with the long version giving more noise reduction than the short, primarily because of the additional lining material. The noise reduction achieved with the acoustically treated long-chord stator vanes was compared with the reduction achieved by an acoustically treated exhaust splitter. The long-chord stator was at least as good as the splitter as a method for incorporating acoustic lining material. In addition, comparing an acoustic three-ring inlet and an acoustic wall-only inlet discloses that the wall-only inlet could be used in an engine where the noise reduction requirements are not too stringent.		
17. Key Words (Suggested by Author(s)) Chord length Fan noise Noise	Suppressor Turbofan	18. Distribution Statement Unclassified - unlimited STAR Category 07
19. Security Classif. (of this report) Unclassified	20. Security Classif. (of this page) Unclassified	21. No. of Pages 97
		22. Price* \$5.00

EFFECTS OF LONG-CHORD ACOUSTICALLY TREATED

STATOR VANES ON FAN NOISE

II - EFFECT OF ACOUSTICAL TREATMENT

by James H. Dittmar, James N. Scott, Bruce R. Leonard, and Edward G. Stakolich

Lewis Research Center

SUMMARY

A set of long-chord stator vanes was designed to replace the vanes in an existing full-scale fan stage. The long-chord stator vanes consisted of a turning section and axial extension pieces that were added behind the turning section. Acoustic damping material was incorporated in the long-chord stator vanes, and tests were performed with two lengths of the vanes. Various inlet and exhaust-duct treatment configurations were used during the testing.

Tests were performed with the two lengths of the long-chord stator vanes with the same acoustically active three-ring inlet. Activating the lining material on the long-chord stator vanes reduced noise, with the long version giving more reduction than the short primarily because of the additional lining material. Noise reductions achieved with the acoustically active long-chord stator vanes were compared with those achieved with acoustically active exhaust splitter rings. The long-chord stator method for incorporating acoustic material in a fan package appears to be at least as good as the exhaust splitter method. In addition, comparisons of an acoustic three-ring inlet and an acoustic wall-only inlet indicate that the wall-only inlet could be used in an engine where the noise reduction requirements are not too stringent.

INTRODUCTION

A set of long-chord acoustically treated stator vanes was designed to replace the stator vanes in an existing 1.83-meter (6-ft) diameter, 1.5-pressure-ratio fan stage (described in ref. 1) in order to investigate the noise reduction possibilities of increased stator chord and this method of incorporating acoustic treatment. The long-chord stator design contained 14 stator vanes, whereas the original design contained 112 stator vanes.

The long-chord stator vanes incorporated acoustic damping material and were considered as possible replacements for conventional acoustic exhaust splitters.

The first part of this two-part report (ref. 2) discussed the results obtained when the acoustic damping material was rendered inactive by covering the surfaces with metal tape. The majority of the data presented in this report are for the configurations where the acoustic damping material was activated by removing the metal tape. Some of the information contained herein is baseline data from the taped long-chord stator vane configurations. Information from the QF-2 and QF-3 fans is also used in various comparisons.

The majority of the taped long-chord stator vane data are given in reference 2, where the aerodynamic effects on noise are discussed. The purpose of this report is to ascertain the effects of this method of incorporating acoustic treatment and the performance of that treatment. The acoustically active long-chord stator vanes were tested in two lengths on the full-scale fan noise test facility at the Lewis Research Center. These stator length variations were tested in conjunction with both an active and an inactive three-ring acoustic inlet. Tests were also run with the active long-chord stator vanes and the inlet where active inner and outer exhaust-duct walls were added to yield a configuration with more acoustic treatment. In addition, tests were conducted with one of the stator lengths with the rings removed from the inlet suppressor to determine the noise reduction obtainable with wall-only inlet treatment in this configuration.

APPARATUS AND PROCEDURE

Fan Stages

Acoustic data from two full-scale, 1.83-meter (6-ft) diameter fans differing in stator design were used in this study. The first fan, viewed from downstream in figure 1(a), had a 1.5 pressure ratio and a 337.4-meter-per-second (1100-ft/sec) tip speed and was designated QF-2. This fan had 53 rotor blades and 112 stator vanes approximately 6.83 centimeters (2.69 in.) in chord. Other pertinent information about this fan is given in references 1 and 2.

The second fan tested, designated QF-1A, was the long-chord stator design. This fan used the QF-1 rotor, which was aerodynamically the same as the QF-2 rotor - varying only in direction of rotation. However, the long-chord stator vanes of the QF-1A stage bear little resemblance to the stator vanes of the QF-2 stage. There were 14 of the QF-1A stator vanes and they were approximately 61 centimeters (24 in.) in turning chord length. The additional length was achieved by adding axial extension pieces behind the turning section. These added axial extension pieces lay in radial planes from the fan centerline. The longer version of these long-chord stator vanes,

with all the extension pieces added and the acoustic material active, is shown in figure 1(b).

Long-Chord Stator Vanes

Developed-view sketches of the fan showing the two lengths of the long-chord stator vanes are shown in figure 2. (Not all of the rotor blades and stator vanes are shown in these sketches.) The design and actual layout of these vanes are discussed in reference 2.

One of the long-chord stator vanes on a work table is shown in figure 3(a) and a sketch of the top view is shown in figure 3(b). The two lengths of the long-chord stator (short and long) are shown in this sketch. The 3/4-length version, which was tested in reference 2 in a taped configuration, is not reported herein in the active version because of a mechanical failure involving the separation of a perforated plate from its backing material. The leading-edge piece is solid aluminum with approximately a NACA-65 series airfoil thickness from the leading edge back to the location where the thickness was equal to the thickness of the following liner section.

The acoustic backing material used on opposite sides of the long-chord stator vanes was of two different thicknesses. The thick material was 0.95-centimeter (3/8-in.) hexcell aluminum honeycomb 2.24 centimeters (0.88 in.) thick with a 0.51-millimeter (0.020-in.) thick facing sheet. The perforated facing sheet had 1.14-millimeter (0.045-in.) diameter holes evenly spaced to give an 11 percent open-area ratio. This thick material had a predicted frequency of maximum noise attenuation of approximately 2400 hertz. The thin material was 0.95 centimeter (3/8 in.) hexcell aluminum honeycomb 0.81 centimeter (0.32 in.) thick with a 0.51-millimeter (0.020-in.) thick facing sheet. The perforated facing sheet had 1.27-millimeter (0.050-in.) diameter holes evenly spaced to give a 5 percent open-area ratio. This thin material had a predicted frequency of maximum noise attenuation of approximately 3600 hertz.

The two acoustic materials were designed according to the theory of reference 3. One thickness was placed on each side of a long-chord stator vane so that the different thicknesses faced each other across the flow channel formed between two stator vanes. The summation of the two honeycomb thicknesses, the two perforated sheets, and the septum thickness determined the overall stator thickness of 3.45 centimeters (1.360 in.).

Test Configurations

The acoustically active long-chord stator vanes were run in a number of combinations with various inlets and both with and without exhaust-duct treatment. A descrip-

tive listing of the configurations tested is given in the following table:

Configu- ration	Inlet		Stator		Exhaust duct	Data figure
	Type	Acoustic material	Length	Acoustic material		
69	Acoustic; three ring	Active	Long	Inactive	Inactive	8, 10, 12
70	Hard; three ring		Long	↓	↓	20(b)
72	Acoustic; three ring	Inactive	Long	↓	↓	15, 16(b), 17, 18
75	Acoustic; three ring	Active	Short	↓	↓	7, 9, 11
76	Acoustic; three ring	Inactive	↓	↓	↓	14, 16(a)
77	Hard; no ring		↓	↓	↓	20(a)
80	Acoustic; three ring	Inactive	↓	Active	↓	14, 16(a)
81	↓	Active	↓	↓	↓	7, 9, 11
82	↓	Active	Long	↓	↓	8, 10, 12
83	↓	Inactive	Long	↓	↓	15, 16(b), 17, 18
88	↓	Active	Long	↓	Active	8, 10, 12, 13, 20(b)
89	↓	Active	Short	↓	Active	7, 9, 11, 19, 20(a)
90	Acoustic; no ring	Active	Short	↓	Active	19

The first series of tests were made with an active three-ring inlet in order to reduce the noise from the inlet that might mask the long-chord stator vane activation results. The acoustic inlet and a sketch showing its dimensions are presented in figure 4, along with a table describing the lining materials. This is the same inlet tested in reference 4 (and referred to therein as suppressor B). In addition to activating the stator lining material surfaces on the two stator lengths, lining material located on the inner and outer exhaust-duct walls was also activated during the course of this testing. A sketch of the exhaust duct and its treatment is given in figure 5.

The second series of tests were performed with an inactive (taped) three-ring inlet in order to indicate the noise removed by the two lengths of active long-chord stator vanes themselves and to obtain some information on the directivity of the reductions. Configurations including inner and outer exhaust-duct treatment were also tested.

Additional tests were performed with active exhaust-duct walls and the active short version of the long-chord stator. During this testing the inlet liner was tested with the

rings removed, leaving only the outer-wall treatment. These tests were done to give an idea of the noise attenuation from the no-ring inlet configuration. The configurations tested and the data obtained are compiled in the appendix, along with data reported in reference 2.

Acoustic Instrumentation

Far-field acoustic data were obtained by 1.27-centimeter (0.5-in.) condenser microphones located on an arc at 10° increments from 10° to 160° . The test site and a plan view of the microphone locations are shown in figure 6. The microphones were level with the fan centerline, 5.79 meters (19 ft) above the ground on a 30.48-meter (100-ft) radius. The acoustic instrumentation and the data acquisition techniques are completely described in reference 5.

Three samples of acoustic data were taken at each test condition and averaged to minimize the effect of short-term fluctuations in the noise. The data were taken at 60, 70, 80, and 90 percent of design speed and were recorded on magnetic tape. One-third-octave-band analyses of the data were performed, and the data were processed by using the methods of reference 6.

RESULTS AND DISCUSSION

Results with Acoustically Active Three-Ring Inlet

As mentioned in the section Test Configuration, the first series of tests were performed with an acoustically active three-ring inlet. This acoustic inlet was used mainly to reduce the noise from the inlet that might mask the long-chord stator vane activation results. The tests were performed first with the lining material on the stator vanes and on the inner and outer exhaust-duct walls in an inactive configuration achieved by covering the surfaces with metal tape. This configuration formed the baseline for this series of tests. The next series of tests were with the acoustic material on the long-chord stator activated by removing the metal tape. Finally, the lining material on the inner and outer walls, as well as that on the stator surfaces, was activated. These tests were performed with the long and short versions of the long-chord stator. The acoustic three-ring inlet was in place for all tests.

The total sound power level spectra for the two stator lengths at 60, 70, 80, and 90 percent of design speed are given in figures 7 and 8. In each part, the top curve is for the taped stator and taped exhaust-duct wall baseline, the middle curve is for the stator surfaces active, and the bottom curve is for both the stator and exhaust-duct wall sur-

faces active.

As can be observed in figure 7, little total power was removed by activating the lining material on the short version of the long-chord stator. This small amount of reduction is most probably the result of the small amount of lining material on these stator surfaces (see fig. 3). Activating the inner and outer exhaust-duct walls gave significantly more reduction, and those surfaces contained much additional material (fig. 5). Activating the long-stator acoustic material (fig. 8) significantly reduced noise because of the large amount of acoustic material, and additional reductions were achieved when the exhaust-duct walls were activated. The acoustic material on the exhaust-duct walls was approximately equal in area to the material on the long version of the long-chord stator. In figures 7 and 8 the bottom spectra, with all material active, are approximately at the same level despite there being more acoustic material for the long (fig. 8) than for the short (fig. 7). In other words, activating the exhaust-duct walls gave more noise reduction in the short stator version than in the long version. This difference in the amount of reduction achieved with the exhaust-duct wall treatment may imply that some noise floor has been reached.

Figures 9 and 10 are for the same combination of test configurations as figures 7 and 8 but for the sound power in the rear hemisphere. The results are similar to those observed in figures 7 and 8. In most cases, this similarity appears to be the result of the rear hemisphere controlling the total sound power attenuation when the acoustic three-ring inlet is installed.

To better illustrate the attenuations observed, the reductions in the rear-hemisphere sound power from the inactive baseline configuration are plotted in figures 11 and 12. As was previously observed, activating the short-stator lining material reduced noise only slightly (fig. 11), but activating the inner- and outer-duct wall lining material reduced noise significantly. A significant noise reduction was attained by activating the long stator surfaces (fig. 12) because of the large area. Activating the duct walls also gave additional attenuation. The double-peaked nature of the attenuations at the 60 and 70 percent speeds for the long stator (figs. 12(a) and (b)) is interesting since it suggests that the blade passage tone and its harmonic are more easily removed by the lining material. Another interesting observation in figures 11 and 12 is that the amount of attenuation appears to decrease as the speed of the fan is increased.

Comparison with Splitter Data

To indicate the total reductions attainable with the long-chord stator and with an exhaust splitter ring, the following comparisons were performed: Because there were no available data for an exhaust splitter on the QF-2 fan, data were taken from the QF-3 fan. The QF-3 fan is nominally the same type of fan as the QF-2 fan; that is, it has the

same tip speed, the same number of rotor and stator blades, and so forth. The primary difference is in the design pressure ratio, which was 1.4 for QF-3 and 1.5 for QF-2. The QF-3 fan was previously tested and reported in reference 4. The data used herein are taken directly from that report. The QF-3 spectra essentially differed only by a relatively small amount in level from those of QF-2.

The two test configurations to be compared used the same three-ring acoustic inlet and the same exhaust-duct wall treatment. The exhaust splitter was run with the QF-3 fan, and the long version of the long-chord stator was run with the QF-1 rotor. The lining material on the exhaust splitter was 0.8 centimeter (0.315 in.) thick with a perforated-facing-sheet hole diameter of 3.17 millimeters (0.125 in.), giving an open area of 6.3 percent. The predicted frequency of maximum noise attenuation was approximately 3600 hertz. The total exhaust-duct treatment area of the QF-3 fan with the exhaust splitter was approximately 8 percent less than the total area of the long-chord stator configuration. In each case the differences are taken between the treated and hard versions of the fan. The base for the long-chord-stator noise reduction is the original fan data with the original QF-2 stator. These two rear-hemisphere sound power reductions are shown in figure 13, for 60 to 90 percent of design speed, to give an indication of the noise-removing capabilities of the long-chord acoustically treated stator vanes.

As shown in figure 13, the reduction achieved with the long-chord stator is typically greater than that achieved with the exhaust splitter at frequencies below the peak of the reduction curve. This advantage was as much as 9 decibels at some frequencies. At the higher frequencies the advantage of the long-chord stator was not as strong. In addition, as the fan speed was increased, the advantage of the long-chord stator appeared to diminish also.

Although the two tests were not perfectly comparable, they show that the long-chord acoustically treated stator vane concept appears to be able to achieve at least as much noise reduction as an exhaust-duct splitter. The small advantage of the long-chord stator version (fig. 13) is quite possibly the noise removed by the taped long-chord stators (ref. 2). This advantage probably carries through from the taped stator vanes to the active stator vanes.

Active Stator Vanes with Inactive Inlet

As mentioned previously the acoustically active long-chord stator vanes were tested with an inactive (taped) three-ring acoustic inlet and hard inner and outer exhaust-duct walls. This testing was performed to give an indication of the noise reduction attainable with only the long-chord stator vanes acoustically treated. These data were compared with those for the configuration where the long-chord stator vanes are covered with metal tape (inactive). The inactive stator data were reported previously in reference 2.

The data from the active and inactive long-chord stator vanes are compared in figures 14 and 15 for 60 to 90 percent of design speed. Figure 14 contains the acoustic power spectra for the short version of the stators, figure 15 for the long version.

As shown in these figures, moderate amounts of acoustic power were removed by activating the stator vane lining material in the long version particularly at the higher speed points. The short version did not remove as much noise. This latter point can possibly be seen more clearly in figure 16, which shows comparison plots for the rear-hemisphere sound power level at 90 percent of design speed. The rear power level is shown here because this is where the largest effect on noise from the activation was expected. Figure 16(a) is for the short version of the long-chord stator vanes, and figure 16(b) for the long version. Here it is seen that the long stator has removed significant amounts of noise but the short stator has removed very little. The short version has considerably less lining material than the long version (approx 1/5), and this at least partly explains the almost total lack of attenuation. The existence of a flow separation near the pylon with the short stator vanes was identified as a large noise source in reference 2. This source is basically downstream of the lining material on the stator vanes and would therefore not be removed by the lining material. This additional noise source quite possibly masks the fan noise reduction by the short vanes.

Figure 17 is a plot of the front-hemisphere sound power level for the 90-percent-speed, long-stator comparison. Comparing this figure and figure 16(b) shows the relative amounts of front and rear power removed by the long-stator activation. As seen, more power is removed from the rear than from the front hemisphere. This is as might be expected considering the location of the lining material. However, the reductions in the front hemisphere are of interest. And the angular variation of the 1600-hertz, 1/3-octave-band sound pressure level, indicating a front reduction, is plotted in figure 18. As shown here, the reductions at this frequency occur from the rear around to the 50° position. The trailing-off of the reduction as the front of the fan is approached suggests that this noise is probably exiting from the rear of the fan and is radiated forward. Nevertheless, this still indicates that activating the long-chord stator vanes reduces noise in the front hemisphere.

Inlet-Outer-Wall-Only Acoustic Results

Tests were run with an acoustically active three-ring inlet and with the same inlet with the rings removed so that only the outer wall was acoustically active. During these tests the short version of the long-chord stator vanes was used, and they and the exhaust-duct walls were activated. To show the comparative results of these two cases, they are both compared with the hard, original 112-stator-vane data (QF-2). The inlet power spectra reduction curves are shown in figure 19 for 60 and 90 percent of design speed.

As can be observed in figure 19, the no-ring-inlet reductions were less than those achieved with the acoustically active three-ring inlet. However, the reductions achieved with the no-ring inlet were significant, amounting to as much as 14 decibels. (Other examples of no-ring-inlet data are given in ref. 7.) The active short stator vanes and the no-ring inlet considerably reduced inlet sound power and could possibly be used in an engine where the noise reduction requirements are not too stringent.

Taped-Stator Noise Source

During the testing of the long-chord stator vanes in the taped configuration (ref. 2), it was determined that extra noise was generated below 1000 hertz when the original 112 stator vanes were replaced with the long-chord stator vanes. Experiments with the long-chord stator vanes and the exhaust-duct treatment performed during the testing discussed in this report gave some indication of the location of this extra noise.

Figure 20 is a plot of the rear-hemisphere sound power spectra for three configurations at 90 percent of design speed. These curves include data for the original 112-vane stator, the inactive (taped) long-chord stator vanes, and the active vanes with active inner and outer exhaust-duct treatment. Figure 20(a) is for the short version of the long-chord stator vanes and 20(b) is for the long version.

Both figures 20(a) and (b) show that noise was added below 1000 hertz by changing from the original stator vanes to the long-chord stator vanes. The aerodynamic testing with the short version revealed that a separation region existed at the trailing edge of the stator vane near the suction side of the pylon (fig. 2). For the short version, this separation region appeared to be a noise source. As can be observed in figure 20(a), activating the lining material, in particular the inner and outer exhaust-duct walls significantly reduced noise in the region of interest, that is, below 1000 hertz, for this short version of the stator. Activating the lining material in the long version of the stator gave little reduction in this range. The short-stator reduction shows that the lining materials in the exhaust are capable of removing noise at frequencies below 1000 hertz. The lack of attenuation in the long version then gives a possible indication of where the noise was generated in this version. If the extra noise were generated along the stator surfaces, the lining material should have caused a reduction. Therefore, a possible explanation is that this extra noise was generated downstream of the long stator, possibly in the wakes, and is therefore not reduced because it is generated downstream of the lining material.

SUMMARY OF RESULTS

A set of long-chord acoustically treated stator vanes was designed to replace the conventional vanes in an existing full-scale fan stage in order to investigate the noise-reduction possibilities of increased stator chord and this method of incorporating acoustic treatment. The long-chord stator vanes were tested in long and short versions with the acoustical material active and with various inlet and exhaust-duct configurations. The following results were obtained:

1. Tests with the two lengths of long-chord stator were performed with an active acoustic three-ring inlet. Activating the lining material on the stator vanes reduced noise, with the long version giving more reduction than the short primarily because of the additional lining material. Adding active inner and outer exhaust-duct-walls further reduced noise.
2. Noise reductions achieved with the active long-chord stator surfaces, active three-ring inlet, and active exhaust-duct walls were compared with the reductions achieved with an acoustic exhaust splitter and the same inlet and exhaust-duct treatment. Comparing the total noise removed revealed that the long-chord stator method for incorporating acoustic material in a fan package is just as good as using an acoustic exhaust splitter. Possibly some of the advantage resulted from a source noise reduction due to the taped long-chord stator.
3. Tests with the two lengths of active long-chord stator were performed with an inactive (taped) acoustic three-ring inlet. Some noise reductions were achieved by this configuration, with the reductions primarily in the rear hemisphere. The front-hemisphere sound power was observed to be reduced in this testing, but the reduction appears to be in the noise that comes from the fan exhaust and that is radiated to the front hemisphere.
4. Significant noise can be removed by using an open inlet with acoustic material on the outer inlet wall only, the short active version of the long-chord stator, and soft exhaust-duct walls. The reductions were not as great as those achieved with the three-ring inlet, but the no-ring inlet configuration could be used in an engine where the noise-reduction requirements are not too stringent.
5. Comparing noise reductions for the active short and long versions of the long-chord stator indicates that the noise generated below 1000 hertz by the long taped version of the stator vanes is probably generated downstream of the stator vanes.

Lewis Research Center,
National Aeronautics and Space Administration,
Cleveland, Ohio, May 14, 1976,
505-03.

APPENDIX - TABULATED ACOUSTIC DATA

This appendix outlines the various configurations of long-chord stator that were tested and presents a compilation of the 1/3-octave sound pressure level data that were obtained. It includes the data taken with the taped versions of the stator, which were included in part I of this two-part report.

The configurations tested in this program are listed in table I. The terminology used in this table can be explained by looking at figure 21. Three inlet configurations were used in the testing (second column, table I). The first is referred to as a three-ring acoustic inlet, the second is the same inlet with the rings removed, and the third is a hard-wall inlet with no rings. The inlets were, in some cases, run with the acoustic material put in an inactive condition by covering it with metal tape. The third column describes the state of the acoustic material (active or inactive) or the lack of acoustic material (hard). The long-chord stator vanes were run in three length configurations, and the fourth column states the length tested. The next column indicates if the lining material on the stator vanes was active or inactive. The final column tells if the acoustic material on the inner and outer exhaust-duct walls was active or inactive.

Tables II to XVIII are the compilation of the 1/3-octave band data for the configurations described in table I. The data are for 10^0 to 160^0 from the fan inlet and for 50 to 10 000 hertz.

REFERENCES

1. Povinelli, Frederick P.; Dittmar, James H.; and Woodward, Richard P.: Effects of Installation-Caused Flow Distortion on Noise from a Fan Designed for Turbofan Engines. NASA TN D-7076, 1972.
2. Dittmar, James H.; et al.: Effects of Long-Chord Acoustically Treated Stator Vanes on Fan Noise. I - Effect of Long Chord (Taped Stator). NASA TN D-8062, 1975.
3. Rice, Edward J.: Attenuation of Sound in Soft-Walled Circular Ducts. Aerodynamic Noise. H. S. Ribner, ed., Univ. Toronto Press, 1969, pp. 229-249.
4. Dittmar, James H.; and Groeneweg, John F.: Effect of Treated Length on Performance of Full-Scale Turbofan Inlet Noise Suppressors. NASA TN D-7826, 1974.
5. Leonard, Bruce R.; et al.: Acoustic and Aerodynamic Performance of a 6-Foot-Diameter Fan for Turbofan Engines. I - Design of Facility and QF-1 Fan. NASA TN D-5877, 1970.
6. Montegani, Francis J.: Some Propulsion System Noise Data-Handling Conventions and Computer Programs Used at the Lewis Research Center. NASA TM X-3013, 1974.
7. Feiler, Charles E.; et al.: Fan Noise Suppression. Aircraft Engine Noise Reduction. NASA SP-311, 1972, pp. 63-102.

TABLE I. - TEST CONFIGURATIONS USED IN PROGRAM

Configu- ration	Inlet		Stator		Exhaust duct
	Type	Acoustic material	Length	Acoustic material	
69	Acoustic; three ring	Active	Long	Inactive	Inactive
70	Hard; no ring	Hard	Long	↓	↓
71	Hard; no ring	Hard	Three-quarter		
72	Acoustic; three ring	Inactive	Long		
73	↓	Inactive	Three-quarter		
74		Active	Three-quarter		
75		Active	Short		
76		Inactive	↓		
77		Hard; no ring			
78	Hard; no ring	Hard	Active		
80	Acoustic; three ring	Inactive	↓		
81	↓	Active			
82		Active		Long	
83		Inactive		Long	
88		Active		Long	
89		Active	Short		
90	Acoustic; no ring	Active	Short	↓	Active Active Active

TABLE II. - NOISE OF QF-1A CONFIGURATION 69 (LONG INACTIVE STATOR,
ACTIVE INLET WITH RINGS, INACTIVE EXHAUST DUCT)

[Data adjusted to standard day of 25⁰ C and 70 percent relative humidity;
SPL re 2×10⁻⁵ N/m².]

(a) 60 Percent of design speed.

FREQUENCY	ANGLE, DEG															
	10	20	30	40	50	60	70	80	90	100	110	120	130	140	150	160
	1/3-OCTAVE BAND SOUND PRESSURE LEVELS (SPL) ON 30.5 METER RADIUS															
50	73.7	72.2	74.8	71.7	71.5	71.7	71.5	73.0	74.7	75.2	74.8	75.7	76.8	76.7	78.2	79.0
63	74.1	73.1	85.0	70.8	71.1	73.5	72.1	72.5	74.5	74.0	73.5	75.1	76.8	77.1	79.1	79.4
80	74.6	74.9	72.6	69.8	70.4	72.1	71.8	71.8	72.8	74.4	74.4	75.7	78.1	78.9	80.3	81.0
100	76.5	76.0	75.8	74.5	73.5	74.0	73.8	74.1	74.3	76.6	77.0	78.2	79.1	80.1	80.6	81.2
125	78.3	78.5	78.2	77.2	76.2	76.8	76.7	76.5	77.2	78.5	78.5	79.8	80.3	80.7	81.0	80.9
160	78.1	78.3	77.3	76.6	75.8	76.0	76.6	76.1	77.6	78.3	79.5	80.2	80.0	80.3	79.8	79.7
200	78.4	80.1	77.4	74.9	73.6	72.9	72.8	73.8	74.3	75.3	76.4	77.0	78.1	78.4	78.8	78.3
250	79.1	79.8	76.8	75.8	73.3	73.6	74.0	75.0	75.8	77.3	78.5	79.7	80.1	79.3	79.0	77.9
315	79.6	80.1	77.6	76.3	75.3	75.8	77.1	77.0	77.6	78.8	79.0	80.1	80.1	79.3	79.3	78.4
400	77.5	77.5	76.8	75.3	74.0	74.8	75.8	76.2	77.8	79.2	80.5	81.4	82.3	80.8	79.5	77.4
500	77.3	77.6	76.3	74.9	74.1	74.1	75.4	76.1	77.8	78.8	79.1	79.8	80.4	79.9	78.4	77.3
630	75.6	76.2	74.9	73.9	73.4	73.7	75.1	75.7	76.9	78.9	79.4	80.5	81.4	81.2	77.1	77.1
800	73.9	74.6	73.9	73.4	73.3	73.6	74.6	76.1	77.1	79.4	80.3	81.8	82.9	83.6	79.6	77.3
1000	73.5	72.9	72.5	72.2	72.2	73.0	74.2	75.5	77.4	79.4	80.7	82.1	83.7	83.5	79.2	77.4
1250	74.4	73.4	72.8	72.1	72.3	73.6	74.9	76.6	78.8	80.8	82.3	83.4	85.1	84.3	80.9	77.5
1600	80.8	80.8	79.2	76.7	76.8	77.2	78.7	80.3	83.3	86.2	88.3	89.6	93.2	92.2	86.7	82.2
2000	86.8	88.1	86.6	83.1	83.9	83.1	84.8	86.3	89.9	93.1	95.3	95.9	100.6	100.8	94.8	90.3
2500	75.8	75.8	74.8	73.2	73.0	74.3	75.6	78.0	80.8	82.5	85.0	86.4	89.0	87.0	82.6	78.4
3150	80.6	79.8	77.8	76.3	74.9	75.1	77.3	79.1	82.3	84.6	86.8	89.2	91.3	89.3	83.9	79.7
4000	85.5	85.1	83.4	82.3	79.1	78.4	79.7	82.5	84.9	87.4	89.4	92.1	94.5	93.2	87.9	83.9
5000	83.3	84.8	83.3	80.4	78.4	77.3	77.8	81.6	84.8	85.9	90.4	90.0	90.9	90.4	88.3	82.4
6300	85.0	84.8	84.0	82.2	79.9	78.0	79.7	80.4	83.0	86.3	89.1	90.3	93.8	94.0	89.1	83.9
8000	85.8	85.8	85.2	84.3	81.7	78.8	76.9	77.4	82.4	84.4	86.4	88.3	89.2	89.6	84.2	79.9
10000	84.0	85.2	85.9	84.9	82.5	79.3	76.0	76.5	81.0	83.2	85.5	86.7	88.0	86.5	83.6	78.2

TABLE II. - Continued.

(b) 70 Percent of design speed.

FREQUENCY	ANGLE, DEG															
	10	20	30	40	50	60	70	80	90	100	110	120	130	140	150	160
	1/3-OCTAVE BAND SOUND PRESSURE LEVELS (SPL) ON 45.7 METER RADIUS															
50	74.4	71.9	73.4	72.2	71.4	71.2	71.5	72.7	74.4	75.4	74.4	76.0	75.7	77.9	79.0	80.8
63	71.7	72.7	81.2	71.1	70.4	70.4	70.6	71.4	72.1	73.2	73.4	75.7	77.4	78.7	79.6	81.5
80	76.2	75.0	73.3	70.7	72.2	73.3	73.2	73.3	73.2	74.5	76.2	77.9	79.5	81.0	82.0	82.4
100	78.8	77.8	77.4	76.4	74.6	74.9	75.4	73.9	76.4	77.4	77.9	80.0	81.3	82.1	83.3	82.6
125	79.4	80.1	80.8	79.3	78.6	78.9	78.3	77.4	79.1	80.1	79.9	82.0	82.3	82.9	83.3	82.3
160	78.5	78.1	78.5	77.6	76.0	77.6	78.0	77.5	78.8	79.5	80.6	82.0	81.8	81.8	81.6	82.2
200	78.4	78.9	76.4	74.4	74.4	74.4	74.2	75.2	75.2	76.7	77.2	79.0	79.5	80.2	80.5	80.2
250	77.7	77.7	76.2	75.2	75.0	73.7	74.8	75.8	77.3	78.2	79.5	81.1	81.3	81.2	81.0	79.6
315	77.5	77.0	76.4	76.7	76.0	76.7	77.4	78.2	79.2	79.7	80.4	81.3	81.5	81.5	81.2	79.7
400	76.2	76.3	77.0	75.7	74.8	76.3	76.7	77.5	79.0	80.5	82.3	83.1	83.2	82.2	80.3	78.7
500	76.2	76.2	75.8	75.3	75.0	75.7	76.5	77.8	78.8	79.5	80.8	81.9	83.0	82.5	80.5	78.7
630	74.4	75.8	74.3	74.3	74.4	75.3	76.3	77.3	78.4	79.8	80.6	81.9	82.9	82.8	79.6	78.5
800	73.8	73.8	73.8	73.8	74.1	75.1	76.0	77.1	78.3	80.3	82.3	83.6	84.6	83.8	80.0	78.2
1000	73.2	73.0	73.0	73.3	73.5	75.0	75.7	77.2	78.5	80.3	81.7	83.4	84.3	83.2	79.0	78.2
1250	73.1	72.8	72.6	72.8	73.5	75.0	76.3	78.0	79.5	81.5	83.5	84.1	85.5	83.8	79.8	77.8
1600	74.0	73.9	73.5	73.5	74.0	76.0	77.0	78.7	80.5	82.7	84.7	85.6	87.4	85.1	80.7	78.1
2000	84.3	81.9	81.9	81.3	81.1	82.4	83.6	85.8	88.8	91.9	95.4	96.0	100.6	98.8	91.8	86.2
2500	78.7	77.4	77.2	76.5	76.7	78.0	79.5	81.7	84.2	86.5	89.5	90.5	94.9	93.0	87.7	83.6
3150	77.9	77.1	75.7	74.7	74.7	76.4	78.2	80.1	82.6	84.9	86.6	88.3	90.2	87.1	82.1	78.6
4000	82.9	83.5	82.0	80.9	79.2	79.3	79.5	82.3	84.7	87.3	90.2	91.3	93.4	91.7	86.0	81.4
5000	81.2	82.4	81.1	79.2	77.9	77.9	78.4	82.2	83.7	85.4	88.6	88.5	90.1	89.1	85.2	80.7
6300	83.8	83.3	83.0	82.0	79.7	79.0	80.3	81.3	83.1	86.6	89.6	91.0	93.8	89.3	85.6	80.4
8000	82.8	83.0	82.3	81.7	79.5	78.3	78.1	79.1	83.0	85.3	87.1	88.6	89.4	88.3	83.0	79.3
10000	82.8	83.4	84.1	83.8	80.9	79.6	77.0	77.6	80.3	82.8	85.0	86.0	87.3	85.6	82.1	77.0

TABLE II. - Continued.

(c) 80 Percent of design speed.

FREQUENCY	ANGLE, DEG															
	10	20	30	40	50	60	70	80	90	100	110	120	130	140	150	160
	1/3-OCTAVE BAND SOUND PRESSURE LEVELS (SPL) ON 45.7 METER RADIUS															
50	84.3	74.8	80.8	79.0	82.8	79.2	80.8	79.7	77.8	77.8	78.3	78.6	79.3	81.0	82.5	83.5
63	72.8	74.3	81.9	74.1	73.8	73.6	74.6	75.3	74.9	75.8	76.4	78.0	80.6	80.9	83.8	84.8
80	76.4	77.6	74.6	73.4	73.3	74.4	73.9	74.8	75.4	76.6	79.6	80.5	82.4	83.9	85.3	86.5
100	81.3	81.6	80.6	80.3	79.8	78.8	79.3	79.3	80.1	81.4	82.9	84.2	85.4	86.4	87.3	87.2
125	84.3	85.1	85.0	82.8	82.5	82.6	82.0	83.0	84.0	84.5	86.3	86.1	87.3	87.5	88.5	86.7
160	82.5	83.6	83.1	81.3	81.3	82.8	82.1	82.8	84.8	86.1	86.8	87.1	87.1	87.3	87.0	86.0
200	82.6	83.1	81.1	78.5	80.1	79.5	79.1	80.1	81.6	82.3	83.3	84.0	84.6	85.1	85.6	85.2
250	80.7	81.2	80.1	79.4	80.1	80.6	81.1	82.6	84.2	85.2	86.7	87.3	87.6	87.1	87.1	86.1
315	80.4	81.2	80.9	82.2	82.6	83.4	83.7	84.6	85.6	86.2	87.2	88.0	88.2	88.1	87.2	85.6
400	79.6	80.4	80.4	81.2	81.7	83.1	83.4	84.6	85.9	87.2	88.4	89.8	89.7	88.4	87.2	86.1
500	79.6	80.4	80.1	80.6	81.8	82.9	83.3	85.1	86.3	87.3	87.9	88.7	89.6	88.6	87.1	85.3
630	78.5	79.5	79.2	79.8	81.2	81.8	83.0	84.2	85.5	86.3	87.2	88.4	89.5	88.3	85.7	84.1
800	77.5	78.5	79.2	79.5	80.5	81.4	82.9	84.2	84.9	86.7	88.0	89.3	90.5	88.5	85.7	83.9
1000	77.5	78.3	78.3	79.0	80.0	81.5	82.7	84.5	85.5	87.2	88.3	89.6	90.7	88.0	85.0	83.4
1250	77.2	77.3	78.0	78.2	79.5	81.2	83.0	84.8	86.5	88.0	89.8	90.3	91.2	88.7	85.3	83.1
1600	77.1	77.6	78.1	78.8	80.3	82.3	83.6	85.6	86.9	88.4	90.4	90.9	91.9	89.4	85.8	83.0
2000	79.0	79.2	79.4	80.4	81.2	84.0	85.0	87.7	89.4	90.9	93.0	93.3	94.4	91.1	87.7	84.8
2500	84.0	84.7	84.8	85.2	84.0	86.5	88.7	90.8	92.3	94.7	98.5	101.3	102.2	100.2	94.5	90.6
3150	80.5	80.1	79.6	79.6	80.5	83.0	85.6	87.3	89.1	90.8	92.8	94.4	95.8	92.9	88.4	85.2
4000	82.9	82.9	82.3	81.1	81.2	83.4	84.6	87.5	89.7	91.5	93.6	94.4	95.8	92.7	88.2	84.5
5000	85.3	87.7	88.3	86.3	85.5	84.1	84.1	87.3	89.3	90.6	94.1	94.1	95.6	94.0	90.3	85.4
6300	85.1	85.1	84.6	83.1	81.9	82.5	84.8	85.8	86.9	89.6	91.4	92.8	94.8	90.9	87.6	82.7
8000	86.6	86.8	86.3	86.5	85.0	84.5	83.6	84.3	88.1	89.6	91.4	92.8	93.1	92.1	87.3	82.8
10000	84.7	85.7	86.5	85.7	83.7	82.9	81.2	82.4	85.0	87.6	89.1	89.9	90.7	88.7	85.7	80.6

TABLE II. - Concluded.

(d) 90 Percent of design speed.

FREQUENCY	ANGLE, DEG															
	10	20	30	40	50	60	70	80	90	100	110	120	130	140	150	160
1/3-OCTAVE BAND SOUND PRESSURE LEVELS (SPL) ON 45.7 METER RADIUS																
50	80.1	77.1	79.4	81.9	78.6	83.2	78.9	80.4	79.7	80.4	81.9	82.5	82.6	83.2	85.2	86.9
63	77.2	77.9	82.7	78.1	77.4	78.2	78.1	78.2	77.4	79.2	79.9	81.7	83.7	84.6	86.7	88.5
80	80.4	81.4	78.6	76.4	76.9	77.8	77.3	78.6	78.4	81.1	82.3	83.7	85.8	87.8	89.3	90.8
100	85.8	85.4	85.4	83.4	82.4	84.1	83.4	82.8	84.4	86.4	87.1	87.9	89.9	90.6	92.1	91.6
125	87.7	88.6	88.4	87.2	85.9	86.4	86.2	87.4	87.7	88.7	89.6	90.3	91.7	91.4	91.7	90.6
160	87.1	86.9	86.7	86.6	85.9	86.9	86.7	88.4	88.7	89.9	90.4	91.3	90.9	90.9	90.1	90.0
200	86.4	86.9	86.1	83.7	84.1	83.6	84.2	84.9	85.7	87.1	87.6	88.5	88.9	89.4	89.7	89.6
250	84.5	85.5	85.7	85.2	85.8	86.3	86.3	88.0	89.3	90.5	91.5	92.6	92.5	92.2	91.8	91.2
315	84.3	85.5	86.7	87.8	88.0	88.5	89.0	89.8	90.5	91.5	92.2	92.9	92.7	92.3	91.3	90.4
400	84.6	84.6	85.6	87.3	86.6	88.5	88.6	89.8	91.3	92.6	94.5	95.7	94.5	93.0	92.3	91.4
500	84.6	85.1	85.9	86.4	87.4	88.4	89.4	90.6	90.9	92.2	93.1	94.2	94.9	92.9	92.2	90.8
630	83.3	84.6	84.9	86.1	86.8	87.9	89.4	90.1	90.4	91.8	92.6	93.9	94.9	93.4	91.1	90.0
800	82.8	83.3	83.9	84.9	85.6	87.1	89.1	90.1	90.4	92.6	93.6	94.7	95.8	93.6	91.1	89.8
1000	81.9	82.9	83.9	84.3	85.1	87.3	88.3	89.6	90.8	92.6	93.9	95.2	95.9	92.9	90.3	89.2
1250	81.4	82.1	83.1	82.6	84.8	86.8	88.3	90.4	91.4	93.3	94.3	95.2	96.4	93.3	90.3	88.3
1600	81.1	81.9	83.3	83.6	85.3	87.3	88.9	90.6	91.6	93.6	94.9	95.7	97.1	94.1	90.4	88.2
2000	81.5	82.5	83.8	84.3	85.8	88.3	89.1	91.3	93.0	94.3	96.2	96.8	98.3	94.8	91.3	88.7
2500	86.1	87.6	87.1	87.3	87.6	88.8	90.6	93.0	95.3	97.1	99.1	100.6	102.1	97.6	94.3	90.2
3150	85.7	86.7	86.6	86.6	87.1	88.4	90.6	92.2	94.2	96.2	98.6	100.7	102.4	99.4	95.1	91.3
4000	85.4	85.9	85.9	85.0	86.1	88.3	89.6	92.0	94.1	96.0	97.5	98.9	99.8	97.0	92.5	88.9
5000	87.0	88.9	89.0	87.2	86.2	87.3	88.0	91.3	93.2	94.7	97.2	97.3	97.7	95.8	92.4	87.9
6300	87.3	87.8	88.2	86.8	86.0	86.7	89.2	90.2	91.5	94.2	95.7	96.6	99.0	95.3	91.7	86.8
8000	88.0	88.7	88.7	88.2	86.3	87.3	87.8	88.5	92.2	93.8	95.0	96.5	96.5	95.5	90.5	86.7
10000	86.0	86.8	88.1	87.4	85.1	85.9	85.7	86.8	89.6	91.7	93.2	93.7	94.3	92.3	89.3	84.3

TABLE III. - NOISE OF QF-1A CONFIGURATION 70 (LONG INACTIVE STATOR,
HARD INLET WITH NO RINGS, INACTIVE EXHAUST DUCT)

[Data adjusted to standard day of 25⁰ C and 70 percent relative humidity;
SPL re 2×10⁻⁵ N/m².]

(a) 60 Percent of design speed.

FREQUENCY	ANGLE, DEG															
	10	20	30	40	50	60	70	80	90	100	110	120	130	140	150	160
	1/3-OCTAVE BAND SOUND PRESSURE LEVELS (SPL) ON 45.7 METER RADIUS															
50	77.9	75.7	75.0	70.4	69.7	69.0	69.5	72.5	68.9	69.0	71.2	70.1	71.2	72.0	73.5	80.2
63	77.9	78.5	81.2	72.4	71.5	70.4	68.5	71.0	70.4	69.5	70.7	71.1	72.2	74.0	75.0	79.7
80	83.3	71.4	70.9	70.4	67.6	67.4	66.8	69.6	67.9	68.9	70.9	72.0	73.1	74.8	76.1	79.8
100	76.8	73.6	73.3	73.4	70.3	71.4	70.6	70.3	72.3	73.1	73.6	74.0	75.4	76.6	77.4	78.5
125	77.1	77.5	75.1	75.0	73.8	72.3	73.6	73.3	74.5	74.6	74.6	76.0	76.1	76.6	76.8	77.8
160	77.5	75.7	74.5	74.9	73.2	72.5	72.5	73.0	73.2	73.2	74.0	75.3	74.5	75.4	75.0	76.8
200	78.5	78.0	75.2	73.4	71.2	70.2	69.4	69.9	69.9	70.7	71.7	73.1	74.0	74.7	74.5	75.6
250	78.9	78.3	75.6	75.3	73.9	73.6	71.6	72.1	72.9	75.1	75.9	76.4	76.4	76.1	76.3	75.3
315	79.7	77.7	76.5	76.7	74.2	73.7	73.0	73.2	73.7	74.3	74.5	75.4	75.8	76.0	75.3	74.1
400	79.3	77.1	77.6	76.3	75.3	73.8	72.8	73.5	74.8	76.1	77.5	78.4	78.1	77.3	75.3	73.9
500	79.9	78.9	77.7	77.4	76.1	73.7	73.1	73.7	73.9	74.6	75.4	76.8	77.4	77.2	74.7	73.3
630	79.3	77.9	77.6	77.8	76.1	73.8	72.6	73.6	74.1	75.1	75.9	77.4	78.1	78.1	74.4	72.8
800	80.4	78.6	79.6	78.9	76.9	75.3	73.8	73.9	73.9	75.4	76.6	78.5	79.4	80.3	75.6	73.6
1000	79.9	79.1	78.8	78.6	77.1	74.3	72.9	73.6	73.8	75.3	77.1	78.7	79.6	80.1	75.4	73.8
1250	81.9	81.2	81.1	80.3	78.6	75.7	74.1	74.6	75.0	76.3	78.3	79.6	81.2	81.1	76.5	73.5
1600	90.6	90.9	89.7	88.9	88.1	84.6	81.4	80.9	80.6	82.1	84.2	85.8	89.2	88.9	83.2	78.6
2000	94.6	95.1	94.2	93.2	92.6	88.9	85.2	84.9	85.1	86.4	88.1	89.8	93.1	92.9	88.2	83.5
2500	82.8	83.0	84.3	83.7	82.8	79.3	76.7	76.0	76.7	78.0	80.2	81.6	83.8	83.0	78.8	75.1
3150	84.7	84.7	84.8	85.2	84.0	80.7	78.3	77.3	77.7	80.3	81.7	83.9	86.5	83.8	79.8	75.9
4000	86.6	87.2	87.0	88.4	86.6	83.9	80.8	80.3	80.0	80.5	84.0	85.1	87.8	85.8	82.0	77.3
5000	82.1	84.7	85.5	83.8	82.5	79.5	78.0	80.3	80.0	82.4	86.5	86.0	86.7	84.5	82.5	77.1
6300	80.8	82.2	83.8	82.0	80.7	78.0	77.7	77.3	78.2	81.8	84.0	84.3	88.8	86.9	82.7	77.5
8000	79.8	81.5	82.0	82.7	81.0	78.5	76.5	74.3	77.2	78.6	81.7	82.8	84.7	84.1	79.1	74.7
10000	75.8	79.5	80.1	80.5	79.2	76.8	73.6	72.5	74.6	76.5	79.5	80.2	82.1	80.5	77.2	72.0

TABLE III. - Continued.

(b) 70 Percent of design speed.

FREQUENCY	ANGLE, DEG															
	10	20	30	40	50	60	70	80	90	100	110	120	130	140	150	160
	1/3-OCTAVE BAND SOUND PRESSURE LEVELS (SPL) ON 45.7 METER RADIUS															
50	93.7	79.5	73.4	71.9	73.2	71.5	71.5	72.2	73.2	74.5	74.5	75.0	76.5	77.7	79.4	82.6
63	107.4	82.1	81.4	71.4	72.4	70.6	71.9	72.2	72.7	73.2	74.9	75.5	77.1	78.4	80.1	83.3
80	83.9	76.4	73.3	71.4	72.6	71.6	71.9	71.6	73.4	74.6	75.9	77.3	79.3	80.1	81.6	83.8
100	80.8	79.6	78.1	77.5	76.0	76.0	75.5	75.3	77.5	78.0	78.3	79.4	81.1	81.3	83.0	82.7
125	82.9	82.6	82.4	82.1	80.3	79.1	78.6	77.6	79.4	79.6	80.6	82.0	82.1	82.4	83.1	82.3
160	81.9	80.1	80.4	79.2	78.4	77.4	77.6	77.9	78.4	78.1	79.6	79.8	80.4	80.2	80.7	80.5
200	83.1	81.8	77.6	76.3	75.1	74.1	74.1	74.6	75.4	76.3	77.9	78.7	79.4	79.6	79.6	79.8
250	82.3	80.7	77.2	78.3	75.3	76.3	76.3	76.8	78.3	79.3	80.7	80.9	81.5	80.7	80.0	80.7
315	82.0	80.0	78.2	79.2	77.5	77.3	78.0	78.2	79.7	79.5	80.5	81.1	81.2	80.5	79.7	78.7
400	82.0	80.5	80.0	79.2	78.0	78.0	78.0	79.2	81.0	82.3	83.2	83.1	83.2	81.7	80.3	79.9
500	82.9	82.1	80.4	80.1	79.4	78.2	78.2	78.4	79.9	81.1	82.2	82.5	83.4	82.4	79.9	79.1
630	82.3	82.1	80.8	80.3	78.8	77.3	77.9	77.9	79.9	81.4	83.3	83.0	84.3	83.1	79.3	78.8
800	82.6	81.3	80.5	81.1	79.1	78.3	78.0	77.8	80.0	81.6	83.0	83.5	84.8	83.3	79.5	79.2
1000	82.5	82.2	81.2	81.4	80.0	78.0	78.0	77.7	79.9	81.4	83.4	83.5	84.5	82.7	79.0	78.4
1250	83.8	83.6	82.4	82.3	80.9	78.6	78.6	78.8	80.6	81.8	83.9	84.4	85.8	83.1	79.1	78.0
1600	86.1	85.9	85.2	85.2	84.0	81.7	80.3	79.9	82.4	82.9	85.4	85.5	87.8	84.2	80.1	78.7
2000	95.6	96.0	97.7	98.3	99.3	97.3	93.0	90.7	91.3	91.7	94.1	94.1	97.7	96.5	90.7	86.9
2500	88.9	90.1	90.5	91.0	91.2	88.9	85.2	84.1	85.6	86.6	88.4	88.5	91.4	89.0	85.1	82.5
3150	85.4	86.2	85.9	86.9	86.0	83.4	81.7	81.0	83.5	85.5	86.5	87.3	89.4	85.2	80.9	78.3
4000	88.8	90.6	90.4	92.7	93.1	91.2	86.2	85.3	86.4	86.5	89.4	90.1	91.8	88.4	83.9	81.0
5000	84.5	87.3	87.6	87.8	86.9	84.8	82.6	84.5	85.1	85.3	88.2	87.1	88.3	85.5	82.5	79.3
6300	84.2	86.4	88.1	87.6	87.1	85.6	84.4	83.4	85.3	88.1	90.3	89.4	92.4	87.3	83.4	79.9
8000	82.5	84.9	85.7	86.9	85.2	84.0	80.8	80.3	84.5	85.3	88.4	88.2	89.0	86.7	81.7	79.4
10000	79.3	83.4	83.8	85.9	84.0	82.5	79.0	78.2	82.0	83.2	86.0	85.5	87.3	83.8	80.5	76.9

TABLE III. - Continued.

(c) 80 Percent of design speed.

FREQUENCY	ANGLE, DEG															
	10	20	30	40	50	60	70	80	90	100	110	120	130	140	150	160
1/3-OCTAVE BAND SOUND PRESSURE LEVELS (SPL) ON 45.7 METER RADIUS																
50	94.2	78.8	79.7	80.3	82.8	79.8	81.5	75.3	79.2	78.8	77.0	78.9	80.3	81.5	82.0	97.0
63	107.6	82.5	81.8	74.1	74.1	73.8	73.3	73.3	74.6	75.1	76.3	78.7	80.8	82.3	84.1	96.5
80	84.2	77.4	74.5	73.4	73.7	73.4	74.4	74.4	76.2	77.2	79.5	81.1	82.5	84.5	86.5	96.1
100	82.0	80.0	79.7	79.0	78.0	78.2	78.7	78.9	80.7	81.2	82.2	83.1	84.5	86.7	86.5	93.9
125	84.8	83.3	82.6	81.8	81.1	80.5	81.1	81.8	82.8	83.1	84.5	84.7	86.0	86.5	86.3	92.5
160	83.8	82.8	81.5	81.5	81.0	81.0	81.3	82.3	82.3	83.2	83.5	84.8	84.3	85.5	85.3	91.4
200	84.6	83.6	81.6	79.3	79.5	79.1	79.0	79.8	80.5	81.6	82.8	84.1	84.8	85.6	85.6	90.4
250	84.3	82.5	81.0	81.6	81.8	82.1	82.6	83.6	85.0	86.3	87.3	88.0	88.0	87.3	86.5	89.8
315	84.5	82.5	82.1	83.3	83.0	83.3	83.5	84.6	85.5	86.6	87.5	88.2	89.0	88.1	87.1	88.5
400	84.8	82.3	82.7	82.7	82.5	83.7	84.5	85.2	86.3	88.0	89.2	89.9	90.0	88.8	87.3	87.7
500	86.1	84.0	83.5	83.3	83.5	83.5	84.3	85.1	86.1	87.1	88.3	89.4	90.0	89.6	86.6	86.5
630	84.5	83.7	83.5	83.7	84.4	83.2	84.2	85.0	85.9	86.7	88.5	89.6	90.5	89.5	85.5	85.6
800	85.6	84.3	84.4	85.6	85.1	84.1	84.4	84.8	85.9	87.4	89.1	89.7	90.6	89.4	85.4	85.1
1000	85.5	84.3	85.0	85.2	84.8	83.5	84.5	84.8	85.8	87.3	89.0	90.1	90.3	89.0	85.0	84.2
1250	85.7	85.1	85.9	85.6	85.7	83.9	84.6	85.2	86.6	87.9	89.7	90.3	91.2	88.7	85.6	83.6
1600	86.8	86.5	87.3	87.2	87.2	85.5	85.2	86.0	87.7	88.3	90.7	91.3	92.2	89.0	85.7	83.6
2000	90.2	91.2	92.6	93.1	92.9	91.4	88.9	88.6	89.6	90.7	92.9	93.3	94.1	91.1	87.6	85.3
2500	98.3	100.1	102.6	104.1	103.4	102.3	99.6	96.1	94.8	95.9	97.3	98.7	99.4	97.8	93.8	91.2
3150	88.6	89.1	89.4	90.2	89.9	87.9	87.4	87.3	89.3	91.1	92.1	94.1	94.9	92.1	87.8	85.0
4000	88.3	89.6	90.0	91.0	90.0	87.8	86.8	87.6	89.4	90.2	93.3	93.8	94.7	92.0	87.6	84.5
5000	90.8	94.1	95.6	97.6	96.8	94.8	91.0	89.8	89.8	90.3	93.1	93.4	93.3	92.0	89.3	85.1
6300	86.6	88.4	90.4	90.1	89.1	87.1	87.1	86.6	87.8	89.6	91.0	90.9	93.8	90.1	86.3	82.6
8000	86.9	88.9	90.4	92.3	90.9	89.4	87.3	85.7	88.4	89.4	91.6	92.1	92.2	90.9	86.3	83.3
10000	83.4	87.6	88.6	90.3	88.2	87.1	85.1	84.4	86.6	87.8	90.5	90.6	90.9	88.8	85.4	82.2

TABLE III. - Concluded.

(d) 90 Percent of design speed.

FREQUENCY	ANGLE, DEG															
	10	20	30	40	50	60	70	80	90	100	110	120	130	140	150	160
1/3-OCTAVE BAND SOUND PRESSURE LEVELS (SPL) ON 45.7 METER RADIUS																
50	93.7	82.0	78.2	83.7	78.2	84.5	79.0	79.0	80.7	82.2	83.5	84.2	82.7	85.0	86.0	91.9
63	107.4	83.2	82.4	76.9	75.9	76.4	76.4	77.2	77.2	78.4	80.2	81.7	83.7	85.4	87.2	94.8
80	84.8	80.0	77.3	76.0	75.3	76.5	77.0	78.3	80.0	81.3	82.8	84.0	86.0	88.5	89.5	93.4
100	86.3	83.3	82.8	82.8	82.0	82.8	82.8	83.5	84.8	86.3	87.3	88.3	89.3	90.3	91.5	93.4
125	87.3	86.8	86.3	86.3	84.8	85.0	85.3	86.5	87.8	88.3	89.0	89.8	90.8	90.8	91.0	91.4
160	87.2	86.0	85.5	85.5	84.7	85.7	86.5	86.5	87.5	88.2	88.7	89.7	89.5	89.5	89.0	90.4
200	87.5	86.8	85.0	83.5	83.5	82.8	83.3	84.0	85.3	86.8	87.8	88.3	89.3	89.5	90.3	89.4
250	86.9	86.2	85.4	86.2	86.2	86.4	87.4	88.4	90.2	91.2	92.2	91.7	92.2	91.7	91.2	91.3
315	88.4	86.4	88.4	88.7	89.4	87.7	88.4	89.4	90.9	92.2	93.2	92.0	92.7	92.2	91.4	90.1
400	89.0	86.2	88.7	88.5	90.5	89.5	90.7	91.7	92.5	93.0	94.5	94.2	93.7	92.7	92.2	90.6
500	89.7	87.7	89.0	89.2	90.2	89.7	90.7	92.0	92.0	92.5	93.7	94.2	94.7	93.0	92.5	90.6
630	88.1	86.9	87.4	88.4	87.9	88.1	89.4	91.4	91.4	92.4	93.9	94.1	95.6	93.1	91.9	89.8
800	89.1	88.6	88.9	88.9	88.6	88.9	89.4	90.9	90.9	92.9	94.1	94.1	95.9	92.9	91.1	89.5
1000	89.3	88.3	89.0	89.0	89.5	89.0	89.5	90.8	91.5	92.3	94.3	94.3	95.8	92.3	90.0	88.7
1250	89.6	89.1	89.3	89.6	89.8	89.6	89.8	91.6	92.3	93.3	95.1	94.9	96.3	92.3	90.3	88.2
1600	90.1	89.6	90.6	90.4	90.1	90.4	90.1	92.1	92.9	93.3	96.4	96.1	97.4	93.4	90.6	88.5
2000	91.0	91.5	92.5	92.7	92.0	91.7	91.0	93.2	94.2	94.2	97.4	97.2	98.7	93.9	91.4	89.1
2500	101.5	101.5	104.3	105.3	103.8	102.5	99.8	98.5	98.0	97.5	99.8	100.3	101.3	97.8	94.3	90.9
3150	96.0	96.5	98.5	99.2	98.0	97.0	95.2	95.2	95.8	96.8	98.3	99.5	100.8	97.5	93.3	90.2
4000	90.8	91.6	92.3	93.1	91.8	91.3	90.6	93.6	94.8	94.8	98.1	98.6	99.3	96.3	91.3	88.5
5000	93.2	95.4	97.5	97.2	95.7	93.7	91.7	93.9	93.7	94.2	97.7	97.0	97.2	94.9	91.9	87.9
6300	89.6	91.9	93.9	92.9	91.6	90.4	90.7	91.6	92.2	94.4	95.9	96.0	97.9	94.4	90.4	86.4
8000	90.0	92.3	93.3	94.8	93.0	92.8	90.3	90.3	93.0	93.5	96.3	95.9	96.3	94.8	90.0	86.5
10000	86.0	89.6	90.8	91.5	90.3	90.1	88.1	89.1	91.1	91.8	94.6	93.9	94.8	92.6	89.5	84.9

TABLE IV. - NOISE OF QF-1A CONFIGURATION 71 (INACTIVE 3/4-LENGTH STATOR,
HARD INLET WITH NO RINGS, INACTIVE EXHAUST DUCT)

[Data adjusted to standard day of 25⁰ C and 70 percent relative humidity;
SPL re 2×10⁻⁵ N/m².]

(a) 60 Percent of design speed.

FREQUENCY	ANGLE, DEG															
	10	20	30	40	50	60	70	80	90	100	110	120	130	140	150	160
	1/3-OCTAVE BAND SOUND PRESSURE LEVELS (SPL) ON 45.7 METER RADIUS															
50	81.0	70.7	72.3	73.5	73.0	72.2	73.0	70.7	70.8	73.5	73.0	73.8	73.7	80.0	78.5	80.7
63	80.5	71.6	81.1	73.0	73.5	72.3	72.5	72.0	71.0	73.0	72.8	73.6	73.5	78.8	77.1	80.4
80	77.9	70.3	68.9	70.9	71.4	70.3	72.1	69.4	69.4	72.6	72.6	73.9	74.9	78.8	77.8	79.8
100	77.5	73.3	73.8	73.0	72.0	73.0	74.3	72.0	72.0	75.0	74.1	76.4	76.8	79.3	78.5	80.0
125	76.0	74.8	74.6	75.0	73.8	73.3	74.6	73.1	74.3	76.5	76.5	76.5	77.5	79.0	78.3	78.5
160	75.3	75.6	75.0	74.1	72.6	73.1	72.8	73.5	73.5	74.0	74.6	75.9	75.0	77.6	76.8	76.7
200	75.3	77.2	75.3	72.8	70.8	71.0	70.8	70.3	71.5	72.7	73.2	74.2	76.2	76.7	76.3	75.7
250	76.4	78.4	75.9	74.7	73.4	74.1	72.9	72.7	73.6	75.9	76.7	77.3	78.2	78.1	76.9	75.8
315	78.4	78.8	77.4	76.6	75.3	74.4	73.8	73.6	74.4	75.8	76.6	76.7	77.4	77.8	75.9	74.6
400	77.6	78.6	77.6	76.6	74.9	74.2	73.9	74.2	75.2	77.1	77.6	78.3	79.1	78.6	76.9	75.3
500	78.1	79.5	78.1	77.3	75.3	74.1	73.6	74.0	75.1	76.5	76.8	77.6	79.5	79.3	76.1	73.7
630	77.9	79.1	78.6	78.1	75.7	74.1	73.4	74.4	75.1	76.6	77.6	78.3	80.1	80.1	76.4	74.0
800	78.0	79.7	79.7	80.0	77.5	76.0	74.8	74.8	75.3	76.8	77.8	78.8	81.0	81.3	76.7	73.9
1000	78.1	80.1	79.6	79.6	76.9	75.1	73.7	74.2	74.7	76.6	78.2	79.3	81.1	80.7	76.9	73.4
1250	79.6	82.1	81.5	81.0	78.4	76.3	74.5	75.5	76.1	77.8	79.6	80.2	82.6	82.0	78.3	73.7
1600	87.4	89.4	88.9	88.4	87.9	84.6	80.4	80.1	80.2	82.2	84.7	86.7	88.9	87.2	83.2	78.8
2000	91.6	94.0	93.8	93.0	93.0	90.3	85.3	84.1	84.8	86.6	89.1	90.6	93.8	91.8	88.3	83.7
2500	80.5	83.7	84.8	84.3	82.7	80.0	76.2	76.3	77.7	79.7	81.8	83.0	85.3	83.5	79.8	74.3
3150	81.8	85.0	85.1	86.0	84.3	81.0	78.0	77.0	78.0	81.6	82.8	84.4	87.0	84.8	80.3	75.1
4000	84.0	87.3	87.7	89.3	87.5	84.8	80.0	78.7	78.7	81.3	84.7	86.5	88.8	86.8	82.3	76.9
5000	78.6	84.4	85.4	84.8	82.7	79.5	74.9	75.8	76.8	78.3	82.1	82.6	84.3	82.6	79.6	72.7
6300	77.8	82.2	84.3	83.2	80.7	78.0	75.2	73.7	74.3	78.0	80.0	80.7	84.5	81.0	77.7	73.0
8000	75.4	81.9	82.4	83.6	81.6	78.7	73.9	71.9	74.4	76.5	79.4	80.9	82.4	81.1	76.2	70.6
10000	71.7	79.0	80.2	82.1	79.4	76.6	71.7	70.1	71.7	74.4	77.6	78.6	80.9	78.5	75.1	69.5

TABLE IV. - Continued.

(b) 70 Percent of design speed.

FREQUENCY	ANGLE, DEG															
	10	20	30	40	50	60	70	80	90	100	110	120	130	140	150	160
1/3-OCTAVE BAND SOUND PRESSURE LEVELS (SPL) ON 45.7 METER RADIUS																
50	76.7	72.7	73.9	74.2	71.7	73.6	76.9	75.7	74.4	74.6	75.7	74.8	77.1	78.4	79.2	83.0
63	74.8	72.6	82.0	73.1	71.3	73.1	76.1	74.0	72.8	73.3	75.1	74.2	77.8	78.6	80.6	82.7
80	75.4	75.6	74.9	74.7	73.4	73.2	73.7	73.9	72.7	73.9	76.1	76.7	79.1	80.1	81.7	83.8
100	78.4	78.8	79.1	78.8	76.3	76.8	76.8	76.3	77.1	77.6	78.3	79.5	81.6	82.3	83.1	83.5
125	81.6	82.6	83.3	83.0	81.8	78.3	80.1	78.6	80.0	81.1	81.5	82.6	82.5	82.1	83.3	82.5
160	80.4	80.6	79.9	79.8	78.4	78.1	79.1	77.8	79.3	79.1	79.9	80.2	80.6	80.8	80.8	80.7
200	80.2	81.3	79.3	77.0	76.7	75.0	76.0	75.8	76.3	77.0	78.2	78.7	80.8	80.3	80.3	79.9
250	79.7	81.4	79.4	78.4	78.2	78.1	78.1	79.2	79.9	81.7	81.9	83.2	82.7	82.1	81.1	80.3
315	80.4	81.2	80.2	80.0	79.4	78.5	78.9	79.2	79.9	81.2	81.4	82.6	82.2	82.0	80.4	79.3
400	79.3	80.9	81.6	80.6	79.1	79.3	79.4	80.1	80.9	82.9	83.3	83.7	83.8	82.4	80.8	79.6
500	80.9	82.6	81.7	81.2	81.1	79.2	79.2	80.4	80.9	82.4	82.4	83.7	84.1	82.9	80.6	78.6
630	79.8	82.2	81.3	81.2	80.5	78.8	79.0	79.5	80.2	82.0	82.2	83.9	84.7	84.0	80.2	78.4
800	80.2	82.4	81.9	82.5	81.4	79.2	79.2	79.9	80.4	82.2	82.5	84.1	85.2	84.2	79.9	78.6
1000	80.2	82.9	82.4	82.7	82.0	79.5	78.9	80.0	80.5	82.2	82.9	84.8	84.9	83.5	79.7	77.7
1250	80.9	83.7	83.2	83.1	82.2	79.6	79.1	80.2	81.2	82.4	83.4	85.2	85.9	84.1	80.1	77.3
1600	82.9	85.7	86.0	86.0	85.0	81.8	80.1	81.6	82.4	83.2	84.7	86.3	87.2	84.9	80.7	77.3
2000	92.2	96.2	98.0	98.7	99.5	96.0	91.9	90.8	90.0	91.0	93.4	95.0	97.0	96.9	90.9	85.3
2500	86.2	90.4	91.5	92.2	92.4	88.9	84.5	84.9	84.7	86.2	88.2	90.0	91.4	90.2	85.4	81.3
3150	82.5	86.4	86.5	87.7	87.5	83.7	81.4	81.9	83.2	85.9	86.2	88.3	89.5	86.9	81.5	78.5
4000	85.2	90.8	91.2	92.8	92.8	89.8	85.4	84.8	84.8	86.1	89.5	90.7	91.6	89.4	84.3	79.9
5000	80.6	87.4	88.6	88.7	87.7	84.7	80.4	81.2	82.6	84.2	86.9	87.7	87.9	86.7	82.7	76.9
6300	81.3	86.6	88.8	88.1	86.8	84.8	82.3	80.4	80.8	83.9	85.4	86.6	89.1	85.8	80.9	77.6
8000	77.6	85.1	86.4	87.8	85.8	83.8	79.6	78.1	80.6	82.6	84.4	86.1	86.6	85.3	79.8	75.0
10000	74.6	83.3	84.6	86.3	84.3	82.5	77.4	77.0	78.3	80.4	83.0	84.4	84.8	82.8	79.0	74.2

TABLE IV. - Continued.

(c) 80 Percent of design speed.

FREQUENCY	ANGLE, DEG															
	10	20	30	40	50	60	70	80	90	100	110	120	130	140	150	160
1/3-OCTAVE BAND SOUND PRESSURE LEVELS (SPL) ON 45.7 METER RADIUS																
50	82.8	76.6	81.3	80.3	82.5	80.5	80.8	78.5	78.5	80.0	80.1	80.6	80.5	82.0	83.3	93.4
63	74.2	75.7	81.6	73.2	73.2	75.2	74.7	75.4	75.7	76.6	77.9	78.8	80.1	82.1	83.6	92.9
80	75.9	77.6	74.1	72.4	73.1	75.2	74.9	75.1	75.9	77.7	79.9	80.2	82.2	84.4	85.7	92.6
100	80.7	81.2	80.8	79.2	78.2	80.2	79.7	79.3	81.3	82.3	83.2	84.1	85.3	86.5	88.0	92.2
125	82.8	85.3	84.8	84.8	81.1	83.8	83.3	83.0	84.5	85.5	87.0	86.7	87.1	87.3	88.1	90.9
160	81.4	83.2	83.2	82.9	81.9	83.6	83.7	84.7	84.7	85.4	85.9	86.2	85.7	85.4	85.4	89.0
200	82.8	84.6	81.8	80.5	80.6	81.0	81.1	81.8	82.1	83.3	84.5	84.6	86.6	87.3	87.5	88.0
250	82.0	83.3	81.8	82.7	83.2	84.7	85.0	85.8	87.3	88.5	88.8	88.9	88.8	88.5	88.5	87.9
315	82.4	83.2	83.1	84.4	84.6	84.9	85.4	86.6	87.4	88.6	89.9	89.6	89.4	88.7	87.4	86.8
400	82.3	83.3	83.3	83.0	83.7	85.7	86.3	87.2	88.3	89.7	90.7	90.6	90.2	89.2	87.8	87.4
500	83.2	84.6	83.9	84.9	85.1	85.9	87.1	87.9	88.7	89.4	89.9	89.8	90.2	90.2	87.9	86.9
630	82.8	84.8	84.0	84.8	84.5	85.0	85.8	86.5	88.0	88.7	89.5	90.3	90.7	89.2	86.5	85.4
800	83.2	85.4	85.4	86.1	85.7	85.6	86.6	86.7	87.7	88.7	89.9	90.5	91.2	89.9	86.6	85.3
1000	82.8	85.5	85.1	85.6	85.1	84.6	85.5	86.3	87.8	88.8	90.1	90.7	91.1	89.0	85.6	84.7
1250	83.1	86.1	85.4	86.3	86.3	84.9	85.6	86.9	88.6	89.3	90.4	91.2	91.9	89.4	85.6	83.7
1600	84.2	86.9	87.4	87.7	87.4	86.2	86.2	86.8	89.3	89.5	91.3	92.1	93.2	90.7	86.3	83.7
2000	87.2	91.1	91.7	93.2	93.2	91.6	88.9	89.0	91.4	91.9	93.9	94.1	95.0	91.9	87.5	85.1
2500	95.3	99.9	101.8	104.9	104.4	103.3	99.1	96.1	95.9	96.8	98.5	99.4	101.1	97.5	92.8	90.4
3150	85.9	89.9	89.5	91.5	91.0	88.9	88.2	88.4	90.2	92.9	93.6	95.0	96.6	93.4	87.9	84.8
4000	85.4	90.2	89.7	92.1	90.7	88.4	86.9	88.4	90.7	91.8	94.4	94.9	96.0	93.0	88.1	84.2
5000	87.0	94.1	95.3	98.5	97.0	95.3	90.1	89.6	90.8	91.1	94.3	94.3	94.5	92.6	89.3	83.4
6300	83.1	88.9	90.2	90.4	88.9	88.0	86.4	85.9	87.9	90.6	91.9	91.7	94.8	90.6	86.2	83.4
8000	82.6	89.7	90.3	92.5	91.4	90.9	87.0	85.2	88.7	89.5	91.5	92.0	92.6	91.2	86.3	81.7
10000	78.7	88.0	88.3	90.3	88.4	87.9	84.3	84.0	85.8	87.6	90.3	89.7	91.3	88.4	84.8	80.4

TABLE IV. - Concluded.

(d) 90 Percent of design speed.

FREQUENCY	ANGLE, DEG															
	10	20	30	40	50	60	70	80	90	100	110	120	130	140	150	160
	1/3-OCTAVE BAND SOUND PRESSURE LEVELS (SPL) ON 45.7 METER RADIUS															
50	78.2	76.0	76.7	81.7	79.7	82.5	78.7	78.5	79.2	80.2	81.4	82.8	82.7	83.2	85.2	87.6
63	75.9	76.4	82.4	76.7	76.4	76.6	77.1	76.4	76.9	78.6	80.9	81.5	83.7	84.9	86.6	88.6
80	78.4	78.6	76.6	76.4	75.7	76.9	77.2	77.6	78.6	80.6	83.2	84.0	85.7	88.1	89.4	91.3
100	82.7	84.1	83.1	82.2	82.1	83.9	83.6	82.9	85.1	85.6	87.1	88.2	89.1	90.1	91.4	92.6
125	84.7	86.7	86.1	85.2	85.1	86.2	85.2	86.9	87.2	87.6	89.4	90.3	90.7	90.6	92.4	90.5
160	85.0	86.0	86.0	85.4	85.9	87.0	86.9	87.5	88.7	88.9	89.0	90.3	89.7	90.0	89.5	88.8
200	86.4	86.7	84.4	84.1	84.4	84.1	83.9	85.1	86.1	86.7	88.7	89.0	90.7	90.7	90.9	89.1
250	84.8	85.9	85.3	85.6	86.6	87.3	88.3	89.3	90.8	91.6	92.4	92.9	93.1	92.6	92.6	91.6
315	85.0	86.5	87.3	88.2	89.0	89.0	89.3	90.0	91.3	92.2	93.5	93.3	93.2	92.5	91.7	91.2
400	85.9	87.3	89.8	88.9	90.3	89.8	90.1	90.9	92.1	93.6	95.1	95.5	94.8	93.1	92.4	91.3
500	86.9	88.1	88.3	88.9	90.8	90.4	90.4	90.8	92.4	92.8	93.9	95.0	94.9	93.4	92.4	91.3
630	85.7	87.2	87.5	88.2	88.5	88.9	90.0	90.9	91.9	93.0	94.0	95.3	95.5	92.9	91.2	90.8
800	85.7	88.3	88.7	90.0	89.3	89.7	90.5	91.2	92.2	93.5	94.5	95.4	95.5	93.0	90.8	90.5
1000	86.4	88.6	88.4	89.8	89.6	89.4	89.9	90.9	92.3	93.1	94.6	95.4	95.8	92.3	90.1	89.3
1250	86.1	88.6	88.6	89.5	89.8	89.6	90.1	91.0	92.5	93.5	95.0	95.9	96.5	92.6	89.8	88.3
1600	86.6	88.8	89.6	89.8	90.6	89.5	90.3	91.6	93.1	93.8	95.8	96.4	97.8	93.5	90.6	88.5
2000	88.2	91.2	91.7	92.0	92.5	90.8	90.8	92.5	94.3	94.8	97.0	97.4	98.6	94.3	91.3	88.9
2500	96.1	100.7	102.4	104.1	104.1	102.1	99.4	95.7	96.5	98.2	99.0	100.7	101.9	97.2	93.7	91.1
3150	92.4	96.6	97.7	99.2	99.4	97.4	95.7	93.9	95.1	97.6	98.1	99.9	101.1	97.8	93.6	90.7
4000	87.1	91.8	91.5	92.8	92.3	91.0	91.3	93.0	94.6	95.6	98.3	98.9	99.5	96.0	92.0	88.6
5000	88.1	95.5	96.3	96.3	96.0	94.0	91.8	92.3	94.1	94.8	97.6	97.4	97.1	94.6	92.5	87.3
6300	86.1	91.7	94.1	93.1	92.6	91.4	91.3	90.9	92.4	95.1	95.9	96.1	98.4	94.3	90.8	88.3
8000	83.8	91.5	93.0	94.6	93.5	92.4	90.5	89.4	92.7	93.5	95.7	96.4	96.5	94.5	90.2	86.1
10000	80.6	89.3	90.3	91.8	90.4	89.6	88.5	88.3	90.5	92.5	94.3	94.4	95.1	92.3	89.1	85.6

TABLE V. - NOISE OF QF-1A CONFIGURATION 72 (LONG INACTIVE STATORS,
INACTIVE INLET WITH RINGS, INACTIVE EXHAUST DUCT)

[Data adjusted to standard day of 25⁰ C and 70 percent relative humidity;
SPL re 2×10⁻⁵ N/m².]

(a) 60 Percent of design speed.

FREQUENCY	ANGLE, DEG															
	10	20	30	40	50	60	70	80	90	100	110	120	130	140	150	160
	1/3-OCTAVE BAND SOUND PRESSURE LEVELS (SPL) ON 45.7 METER RADIUS															
50	67.8	65.8	67.0	67.5	66.3	67.0	66.5	67.5	68.3	69.0	68.3	69.3	70.8	72.0	72.5	74.2
63	69.3	68.5	65.3	65.3	67.5	68.3	67.0	67.3	67.8	68.0	68.3	70.0	70.8	72.8	74.5	75.4
80	68.6	69.6	67.1	65.8	65.3	65.8	65.3	65.6	66.3	68.3	70.1	72.3	73.8	74.8	76.3	76.7
100	72.6	72.1	70.8	71.8	70.8	68.6	69.1	70.3	71.1	72.6	73.6	74.1	75.1	76.3	77.3	77.2
125	74.1	75.8	74.8	74.1	71.8	72.1	72.8	71.8	73.1	74.1	74.8	75.8	74.8	76.8	77.3	80.2
160	74.1	74.8	74.3	73.1	72.8	71.8	72.3	72.6	73.3	73.6	74.3	75.3	75.3	76.3	75.8	76.2
200	73.8	76.0	74.0	71.3	70.3	69.0	68.8	69.3	69.8	71.0	72.3	73.0	74.3	74.3	74.5	74.7
250	75.8	76.8	74.5	73.3	71.3	70.5	71.0	71.0	72.0	74.3	75.3	76.5	76.5	75.8	75.8	74.7
315	76.5	76.7	75.0	74.2	72.7	71.7	72.7	72.7	73.2	74.2	74.5	75.5	76.0	75.5	75.5	74.1
400	75.5	75.2	75.2	73.2	72.0	71.0	71.5	71.5	73.7	75.2	76.5	77.7	78.5	76.5	75.5	73.6
500	77.1	77.3	75.8	73.6	72.6	71.3	71.8	72.3	73.6	74.8	74.6	76.3	76.6	76.6	74.3	72.7
630	75.5	77.0	75.7	74.0	72.7	71.0	71.5	72.5	73.2	74.7	75.2	76.5	77.5	77.2	74.5	72.9
800	76.2	78.2	76.7	75.7	73.5	72.0	71.7	72.2	73.2	75.2	76.2	78.2	79.0	79.5	75.0	73.1
1000	77.4	78.7	77.4	76.4	74.2	72.7	71.7	71.9	73.4	75.2	76.7	78.7	79.4	78.9	74.7	73.1
1250	79.6	81.5	80.2	78.0	76.8	74.2	72.6	73.3	74.6	76.6	78.6	79.8	81.2	80.7	76.6	73.2
1600	86.6	89.8	93.3	88.6	84.6	87.3	81.8	79.6	80.6	81.3	85.1	86.3	91.1	89.8	83.3	80.2
2000	90.1	93.8	97.8	91.8	88.8	92.3	86.3	83.6	84.1	86.3	88.8	89.6	94.8	94.3	89.1	86.0
2500	81.0	84.0	84.0	82.8	80.3	77.3	74.8	74.8	76.8	78.3	80.3	82.3	84.3	82.3	78.3	74.2
3150	83.2	86.5	85.7	85.7	83.7	80.2	77.2	76.7	78.7	81.0	83.2	85.5	87.2	85.7	80.5	76.2
4000	84.9	89.4	88.1	88.9	86.2	82.9	78.4	78.4	79.9	81.1	84.7	86.7	89.2	88.4	82.8	78.6
5000	80.8	86.3	86.3	85.5	83.0	79.3	74.8	75.0	77.3	78.8	83.0	83.1	85.8	84.0	81.3	75.5
6300	80.2	83.7	84.0	83.2	81.5	78.3	74.8	72.7	75.2	78.0	80.2	82.3	84.2	83.0	78.7	73.5
8000	79.0	83.8	83.8	83.5	82.0	79.5	73.7	71.5	76.0	76.7	80.0	81.9	84.8	82.5	78.5	73.6
10000	75.9	81.7	82.5	82.2	80.7	77.9	71.7	70.2	73.4	74.7	78.0	79.8	82.2	79.9	77.2	71.6

TABLE V. - Continued.

(b) 70 Percent of design speed.

FREQUENCY	ANGLE, DEG															
	10	20	30	40	50	60	70	80	90	100	110	120	130	140	150	160
	1/3-OCTAVE BAND SOUND PRESSURE LEVELS (SPL) ON 45.7 METER RADIUS															
50	73.9	70.1	72.6	72.4	71.4	71.6	72.1	72.9	72.6	73.4	73.1	74.9	76.1	77.1	78.6	79.7
63	70.8	72.0	70.8	71.3	69.8	69.8	70.5	70.3	70.3	72.0	73.0	74.5	77.0	78.3	79.5	80.7
80	76.1	76.9	73.4	70.9	70.4	71.4	72.4	72.4	72.4	73.9	74.4	77.1	79.4	80.4	82.1	82.8
100	78.4	78.9	78.1	76.9	73.4	75.4	74.6	74.4	75.9	77.4	78.1	79.9	81.1	81.9	82.6	83.0
125	79.3	80.1	80.8	80.3	77.6	77.8	78.1	77.1	78.8	79.6	80.6	82.1	82.1	82.3	83.6	82.2
160	79.6	79.4	78.6	77.9	76.4	76.9	77.4	77.1	78.9	79.4	79.9	81.1	81.6	81.9	81.1	81.2
200	78.9	79.9	77.4	74.9	74.1	74.6	74.4	74.9	75.4	76.4	77.6	78.6	79.4	79.9	80.4	79.8
250	78.6	79.6	76.1	76.3	74.1	74.8	75.3	75.8	77.1	79.1	80.1	81.1	81.8	80.8	81.1	80.2
315	78.5	79.3	77.5	77.5	76.3	77.0	77.8	78.3	78.8	80.0	80.3	81.3	81.0	81.0	80.3	79.7
400	78.2	78.7	79.0	77.5	76.0	76.2	76.7	77.0	79.2	80.7	82.2	83.0	83.5	81.7	80.2	78.9
500	78.6	79.8	78.3	77.3	76.1	75.8	76.8	77.8	78.3	80.1	80.3	81.3	82.8	82.3	80.1	78.5
630	78.7	79.7	78.2	77.2	76.2	75.4	76.2	77.2	78.2	79.7	80.4	81.4	82.9	82.7	79.2	78.3
800	78.8	80.0	79.0	78.0	76.3	76.0	76.5	77.3	78.3	80.3	81.8	83.3	83.8	83.3	79.5	78.2
1000	79.2	80.7	79.7	78.7	77.0	76.2	76.5	77.2	78.7	80.0	81.2	83.0	84.5	82.5	79.2	77.6
1250	81.3	82.6	81.6	80.3	78.3	77.1	76.8	77.8	79.6	80.3	82.6	83.6	85.3	83.3	79.6	77.4
1600	83.1	85.1	84.2	83.2	81.5	79.3	78.6	79.3	80.8	81.8	84.6	85.1	87.2	84.5	80.3	78.0
2000	93.0	95.3	96.0	98.0	94.8	90.5	88.5	87.3	88.3	90.8	94.5	94.5	99.0	96.8	90.5	86.7
2500	85.3	88.6	88.1	88.8	86.1	82.8	81.1	81.1	82.8	84.6	87.3	87.9	90.8	88.6	84.6	81.0
3150	83.7	86.7	86.5	86.0	84.5	82.0	80.5	80.0	82.7	84.7	86.2	88.0	89.0	86.2	82.0	78.2
4000	87.2	91.6	91.6	92.6	91.4	88.3	82.9	84.1	84.7	85.9	90.3	91.2	93.3	90.6	86.6	82.0
5000	82.6	87.9	88.4	87.6	85.9	82.9	79.4	80.4	81.9	83.4	87.1	87.0	89.1	86.9	83.9	79.6
6300	83.5	87.2	88.2	88.5	86.2	84.5	81.7	78.9	80.9	83.7	85.9	87.8	89.2	87.0	82.4	77.7
8000	81.5	86.5	86.8	87.5	85.5	83.8	79.8	77.8	81.3	82.3	84.5	86.9	88.8	86.0	81.5	77.8
10000	78.7	85.5	86.8	87.0	84.8	82.8	78.2	76.0	79.0	80.5	83.3	84.6	86.5	84.0	81.0	75.8

TABLE V. - Continued.

(c) 80 Percent of design speed.

FREQUENCY	ANGLE, DEG															
	10	20	30	40	50	60	70	80	90	100	110	120	130	140	150	160
1/3-OCTAVE BAND SOUND PRESSURE LEVELS (SPL) ON 45.7 METER RADIUS																
50	81.3	75.6	77.8	79.1	82.6	78.6	81.6	76.6	79.1	79.1	78.1	79.6	80.6	81.3	82.3	83.0
63	72.6	74.8	73.8	73.3	73.6	73.1	73.3	73.6	74.3	74.8	76.8	78.1	81.1	81.1	83.3	85.2
80	76.4	77.1	74.9	73.9	72.9	72.9	73.9	74.1	74.9	77.9	79.6	80.9	82.4	84.1	85.6	86.5
100	81.1	81.6	80.9	80.1	78.9	78.4	78.9	78.4	79.6	81.9	83.1	83.6	86.1	86.6	86.9	87.5
125	84.1	85.4	85.1	83.9	81.9	82.9	80.9	82.4	83.6	84.4	86.4	86.9	87.1	87.9	87.9	86.5
160	82.8	84.1	83.6	81.3	81.3	82.1	82.6	83.6	84.1	85.1	85.6	86.8	86.3	86.3	86.1	86.2
200	82.4	83.4	81.6	79.9	80.1	79.4	79.4	79.9	81.4	82.6	83.1	84.4	85.1	85.4	85.6	85.3
250	80.8	82.3	81.0	81.0	80.3	80.8	81.0	82.8	84.3	86.0	87.3	88.0	87.5	87.8	87.8	86.9
315	80.3	82.0	82.0	83.5	82.5	83.5	83.8	84.5	85.3	87.0	87.3	88.3	88.8	88.5	87.0	86.2
400	81.3	81.6	81.8	82.3	81.8	82.8	83.6	83.6	86.1	87.3	89.1	90.1	89.8	88.8	87.8	86.7
500	82.4	82.9	82.9	82.4	82.9	83.1	83.9	84.6	85.9	86.9	87.6	88.9	89.9	89.4	87.4	86.0
630	82.2	82.7	81.9	82.4	81.7	81.9	83.2	83.7	84.7	86.4	87.7	88.5	89.4	88.7	85.4	85.1
800	81.0	82.8	83.0	82.8	82.0	82.0	83.0	83.5	85.0	87.0	88.0	89.3	90.3	89.0	85.0	84.6
1000	81.7	83.2	83.0	82.7	82.2	82.2	83.0	84.2	85.5	87.2	88.5	89.7	90.5	88.2	85.0	83.6
1250	82.6	84.6	84.6	83.8	82.1	82.3	83.3	84.3	85.8	87.3	89.3	90.3	91.3	88.3	84.6	83.0
1600	83.8	86.1	86.3	85.8	84.3	83.8	84.3	85.1	86.8	87.8	90.1	90.6	92.3	89.3	85.6	83.2
2000	86.3	89.3	89.3	90.3	88.6	87.1	86.3	87.3	89.8	90.8	93.1	93.3	94.8	91.6	87.3	84.5
2500	94.2	97.9	99.4	99.4	98.1	95.6	93.2	91.9	92.9	94.9	95.9	99.7	101.2	101.2	92.7	89.3
3150	85.5	88.7	88.7	88.7	87.2	85.7	86.0	86.5	88.7	90.7	92.2	93.8	95.7	92.5	88.0	84.2
4000	86.4	90.1	90.9	90.9	88.9	87.1	85.4	86.9	89.5	90.2	93.1	94.3	96.1	92.9	88.1	84.6
5000	87.4	93.6	95.4	95.6	93.9	91.1	87.1	87.1	88.3	89.9	93.1	93.4	95.8	92.9	89.6	84.8
6300	85.5	89.5	90.2	90.0	88.2	86.5	85.3	84.3	86.8	89.3	90.8	92.6	93.8	91.3	86.8	82.0
8000	84.8	90.1	90.8	91.6	89.6	88.6	85.3	83.5	87.3	88.3	90.5	92.2	94.0	92.0	86.8	82.6
10000	82.0	88.3	89.3	90.1	88.3	87.1	83.1	82.1	85.1	86.3	88.8	90.0	92.1	89.0	85.6	80.4

TABLE V. - Concluded.

(d) 90 Percent of design speed.

FREQUENCY	ANGLE, DEG															
	10	20	30	40	50	60	70	80	90	100	110	120	130	140	150	160
1/3-OCTAVE BAND SOUND PRESSURE LEVELS (SPL) ON 45.7 METER RADIUS																
50	79.0	76.0	79.2	82.5	80.7	82.2	82.7	79.0	81.2	83.5	82.7	85.2	82.5	83.0	85.5	87.9
63	77.0	79.0	77.5	77.3	77.3	77.3	77.3	77.5	78.0	78.0	80.5	81.0	83.0	85.3	87.0	89.4
80	79.5	80.8	78.5	77.0	76.3	76.0	77.5	77.5	79.0	80.0	83.3	83.8	86.3	87.8	89.8	90.6
100	85.8	85.3	85.1	84.3	82.8	82.8	83.3	83.1	84.6	85.6	87.6	88.6	89.3	90.1	92.1	91.7
125	86.3	88.0	87.0	87.0	85.5	86.3	85.8	87.3	87.8	88.5	90.0	90.3	91.0	91.5	92.5	90.4
160	86.3	86.8	86.1	86.1	85.8	86.1	86.6	87.8	88.6	89.3	90.6	91.1	90.8	90.8	90.1	90.5
200	85.8	87.1	85.6	83.8	83.6	83.3	84.3	85.1	85.8	86.8	87.8	88.4	89.3	89.8	89.8	90.0
250	83.5	85.2	85.7	85.5	85.8	86.0	86.7	87.8	89.3	91.8	91.8	92.5	92.2	92.7	92.0	91.4
315	85.2	86.7	87.7	88.7	87.9	87.9	88.2	89.2	90.2	91.4	92.2	92.7	92.7	92.2	91.4	90.8
400	84.8	85.5	87.0	87.8	87.5	88.3	89.0	90.0	91.5	93.3	94.5	95.0	94.3	92.3	92.8	91.6
500	85.5	86.5	86.5	87.2	88.2	88.2	89.2	90.5	91.5	92.2	93.2	94.5	95.0	93.5	92.2	91.3
630	85.4	86.4	85.9	86.9	87.2	87.7	88.7	90.2	90.9	91.7	92.7	93.7	95.2	93.4	91.4	90.6
800	85.2	86.4	86.2	86.7	86.7	86.9	88.7	89.7	90.4	91.9	93.2	94.2	95.2	93.2	91.2	90.3
1000	84.9	86.6	86.6	86.4	86.6	87.1	88.1	89.6	90.9	91.9	93.4	94.6	95.4	92.1	90.1	89.3
1250	85.5	86.5	87.0	87.2	86.7	87.2	88.2	89.5	91.2	92.5	94.2	95.0	96.0	92.2	90.0	88.1
1600	85.8	88.3	88.8	88.3	88.0	87.8	88.5	90.5	92.3	92.8	94.8	95.6	97.5	93.5	90.8	88.2
2000	87.4	89.9	90.2	89.7	89.5	89.2	88.9	91.4	93.2	93.7	96.2	97.0	98.9	94.7	91.2	88.3
2500	93.6	97.6	99.3	100.3	100.3	95.8	95.1	93.8	95.3	97.1	98.8	99.9	101.6	97.8	93.1	90.5
3150	89.4	92.9	93.6	95.4	94.4	91.4	91.4	91.9	93.9	96.1	97.4	99.4	100.6	97.9	93.4	89.8
4000	87.9	91.6	91.6	91.7	90.7	89.3	89.4	91.9	93.9	93.9	97.7	98.2	99.9	96.7	92.2	88.6
5000	89.1	94.8	95.3	94.8	94.1	91.8	89.6	91.3	92.8	93.8	96.8	96.1	98.3	95.3	92.1	87.8
6300	87.2	91.1	91.4	91.7	90.7	89.4	89.4	89.2	91.4	93.2	95.2	96.5	97.7	94.7	90.7	86.2
8000	86.9	91.7	92.5	93.5	92.0	90.7	88.7	88.4	92.5	93.0	95.0	96.1	97.4	94.7	90.5	86.5
10000	83.4	89.7	91.0	91.2	89.5	88.5	86.7	87.2	90.2	91.2	93.5	93.8	95.2	92.4	89.5	85.1

TABLE VI. - NOISE OF QF-1A CONFIGURATION 73 (INACTIVE 3/4-LENGTH STATOR,
INACTIVE INLET WITH RINGS, INACTIVE EXHAUST DUCT)

[Data adjusted for standard day of 25⁰ C and 70 percent relative humidity;
SPL re 2×10⁻⁵ N/m².]

(a) 60 Percent of design speed.

FREQUENCY	ANGLE, DEG															
	10	20	30	40	50	60	70	80	90	100	110	120	130	140	150	160
	1/3-OCTAVE BAND SOUND PRESSURE LEVELS (SPL) ON 45.7 METER RADIUS															
50	71.3	70.0	68.0	67.5	68.5	69.1	67.6	67.5	72.5	71.3	73.0	71.4	73.0	74.1	75.0	76.0
63	69.8	70.5	67.3	64.3	68.7	70.3	68.3	66.8	71.3	70.3	71.3	71.4	80.7	74.8	75.8	76.7
80	70.0	70.3	67.3	65.2	67.0	69.2	66.3	67.3	70.5	70.5	71.7	72.6	73.7	75.7	76.3	77.9
100	73.0	72.8	72.7	71.2	70.3	72.0	72.2	71.2	72.3	73.0	73.8	75.1	75.8	76.8	78.5	78.0
125	74.0	75.3	75.2	73.0	72.5	73.3	72.7	72.7	73.5	74.8	76.3	76.6	76.2	77.3	77.8	77.9
160	75.7	76.2	75.8	73.8	72.7	72.8	72.5	73.0	75.0	73.8	75.3	75.4	75.7	76.3	76.0	76.7
200	75.9	76.9	75.0	71.7	71.0	70.8	70.5	71.5	72.7	72.2	73.9	73.8	74.9	75.0	75.7	75.6
250	77.1	78.3	76.8	74.8	72.8	73.0	73.5	73.5	74.3	74.8	77.0	77.0	77.5	76.5	76.3	75.0
315	78.1	78.6	77.5	75.5	74.5	74.5	74.1	74.3	74.6	75.6	77.0	77.1	77.5	76.0	76.3	74.7
400	77.8	78.6	77.8	75.3	74.0	74.3	73.5	74.0	75.1	76.8	77.6	78.0	79.0	77.6	76.0	74.8
500	78.5	80.0	78.0	75.8	74.1	74.1	73.8	74.3	75.0	76.5	77.6	77.7	79.0	78.0	75.5	74.9
630	78.2	80.2	78.6	76.1	74.6	73.7	74.1	74.1	75.1	76.9	77.6	78.0	79.4	79.1	75.9	74.3
800	78.9	80.6	79.8	77.8	75.9	74.8	74.6	74.4	75.3	77.3	78.3	79.0	81.1	80.9	76.4	74.5
1000	79.4	81.0	79.9	78.0	76.2	74.5	74.2	74.2	75.5	77.0	78.5	79.1	81.5	80.7	76.0	74.4
1250	80.7	82.9	81.7	79.5	77.7	76.0	74.7	75.0	76.9	78.5	80.0	80.5	83.2	81.5	77.5	74.9
1600	87.2	91.2	89.3	88.0	84.8	83.3	79.8	79.2	80.5	82.7	85.7	87.1	90.2	88.0	83.2	79.1
2000	93.0	98.7	96.0	94.8	91.2	89.8	85.7	84.2	85.5	87.8	91.5	92.4	96.3	95.3	90.0	85.2
2500	81.9	85.4	85.1	83.2	81.1	79.1	76.1	76.2	77.7	80.2	82.2	83.3	85.6	83.4	78.7	76.1
3150	83.0	86.8	86.0	85.3	83.3	81.2	76.8	77.3	79.0	81.8	83.6	85.6	87.5	86.2	80.7	76.4
4000	85.0	89.7	88.9	89.3	87.2	84.4	79.9	79.4	80.7	83.5	85.7	87.3	90.4	89.2	83.7	78.9
5000	79.5	85.5	86.5	85.5	82.3	79.8	76.1	75.8	77.8	79.6	82.5	83.4	86.1	84.6	80.3	76.4
6300	79.0	84.8	85.3	83.7	81.3	80.8	74.3	74.5	75.7	78.5	80.5	83.5	85.0	85.0	78.3	73.9
8000	75.9	84.5	83.5	83.5	81.9	80.2	73.5	73.7	75.7	78.0	80.3	81.3	84.3	82.5	78.5	73.0
10000	72.1	82.3	81.7	81.3	79.5	77.7	71.2	71.0	72.1	75.3	77.1	79.0	81.7	80.5	76.7	70.4

TABLE VI. - Continued.

(b) 70 Percent of design speed.

FREQUENCY	ANGLE, DEG															
	10	20	30	40	50	60	70	80	90	100	110	120	130	140	150	160
1/3-OCTAVE BAND SOUND PRESSURE LEVELS (SPL) ON 45.7 METER RADIUS																
50	73.7	74.9	72.6	73.6	70.4	73.7	72.7	73.4	73.1	73.4	74.2	74.8	76.1	77.7	78.7	80.9
63	70.5	72.6	70.5	72.0	69.5	71.0	71.6	72.1	71.1	72.3	73.0	74.6	82.0	78.5	80.0	80.7
80	74.6	75.9	73.3	72.1	72.8	70.6	71.3	71.9	71.6	73.3	74.4	76.8	78.4	79.9	81.1	82.6
100	78.1	78.9	77.2	76.4	74.4	74.2	73.4	74.7	75.4	76.7	77.7	79.8	81.1	81.7	82.9	83.6
125	79.1	81.5	81.6	81.1	78.6	77.6	77.5	77.5	79.5	80.0	80.3	82.2	82.5	83.3	83.3	81.8
160	79.2	80.1	79.1	78.6	76.7	77.6	77.9	78.9	79.7	78.9	80.2	81.0	80.9	81.6	80.9	81.3
200	79.1	80.7	77.7	75.2	75.4	75.2	75.2	76.2	76.2	76.1	76.9	78.5	79.4	80.2	80.6	79.6
250	79.6	81.2	79.1	77.7	76.6	76.9	77.4	78.9	79.7	80.6	81.7	82.6	82.7	82.4	81.2	80.3
315	78.5	80.8	79.1	78.8	77.3	78.6	78.8	80.1	80.3	81.1	81.8	82.6	82.0	81.6	81.0	79.9
400	79.4	80.4	81.1	79.7	77.7	78.9	78.7	80.4	80.6	81.7	82.7	83.8	83.9	82.7	81.1	79.9
500	80.6	82.1	81.6	80.1	78.3	79.1	79.6	81.1	81.3	81.8	82.4	83.2	84.4	83.6	80.9	80.1
630	79.9	82.6	81.2	79.7	76.7	78.2	78.7	80.1	80.6	82.1	82.7	83.7	84.9	83.7	80.2	78.8
800	80.0	82.5	82.1	80.0	76.1	78.3	79.0	80.1	80.6	82.5	82.8	84.4	85.5	84.5	80.3	78.9
1000	80.8	82.8	82.3	81.6	79.4	78.6	78.8	80.3	81.4	82.3	82.9	84.5	85.8	83.9	79.9	78.6
1250	81.6	84.3	83.5	82.0	79.3	78.8	79.1	80.8	82.3	83.0	83.8	85.2	86.8	84.1	80.6	78.8
1600	83.4	86.2	85.6	84.1	82.1	80.2	80.1	81.2	83.2	84.1	85.4	86.0	88.4	85.2	81.2	78.8
2000	93.8	97.5	98.1	97.0	94.5	91.1	89.3	88.6	90.8	91.3	93.8	97.1	98.8	96.5	92.1	87.0
2500	87.7	91.0	91.7	90.8	88.3	85.5	83.7	83.9	86.2	86.7	89.2	91.3	93.2	91.2	87.2	83.6
3150	83.8	87.6	87.3	87.0	84.8	83.5	81.0	82.6	84.1	86.0	87.0	89.1	90.1	88.1	82.3	79.2
4000	85.9	92.2	92.9	92.5	91.0	88.5	84.7	85.3	86.1	88.1	90.3	91.2	94.0	90.8	85.7	81.6
5000	81.6	88.3	89.8	88.8	86.6	83.8	81.1	82.1	83.9	84.8	87.6	88.2	91.3	87.8	83.8	80.2
6300	82.1	88.5	89.8	88.5	87.0	87.3	80.8	81.1	81.8	84.5	85.8	88.8	89.6	89.0	82.0	77.9
8000	78.3	87.2	87.2	87.4	85.7	84.2	78.7	80.2	82.1	83.9	85.1	86.2	88.7	86.0	81.7	76.9
10000	75.1	85.6	85.8	85.8	83.7	82.4	76.7	77.9	78.7	81.1	82.9	84.1	86.1	84.2	79.9	74.0

TABLE VI. - Continued.

(c) 80 Percent of design speed.

FREQUENCY	ANGLE, DEG															
	10	20	30	40	50	60	70	80	90	100	110	120	130	140	150	160
	1/3-OCTAVE BAND SOUND PRESSURE LEVELS (SPL) ON 45.7 METER RADIUS															
50	82.2	75.9	82.6	78.2	83.9	79.9	83.7	80.6	82.9	82.9	81.2	81.8	81.7	81.7	83.1	83.8
63	74.2	75.0	74.3	73.0	73.0	75.5	73.7	75.2	75.3	76.3	77.2	77.4	83.3	82.0	83.5	84.9
80	75.5	77.1	74.3	73.3	73.1	74.8	72.8	73.6	75.5	77.3	78.5	79.1	81.8	82.6	85.6	86.7
100	80.5	81.0	80.0	78.8	79.0	79.7	77.5	77.8	80.8	81.0	82.0	83.1	84.8	85.7	87.3	87.2
125	81.9	82.9	83.3	81.3	80.4	82.1	80.9	81.9	83.8	83.8	85.4	85.8	86.9	87.3	87.8	87.0
160	81.8	82.4	82.9	81.8	81.3	82.9	82.9	83.8	85.3	84.9	85.8	86.9	85.9	85.9	86.6	86.2
200	82.1	83.6	81.6	79.8	80.9	80.3	80.4	81.6	82.6	82.3	82.9	83.5	84.9	85.8	85.9	85.2
250	80.7	82.7	82.0	81.7	81.9	82.4	82.5	83.7	86.2	87.2	88.0	88.4	88.4	88.4	88.0	86.2
315	81.0	82.7	82.7	83.7	83.7	84.0	84.0	85.5	87.7	87.5	88.4	89.1	88.9	88.4	87.0	86.3
400	82.2	83.7	84.2	83.6	83.4	84.6	84.4	85.2	87.1	88.6	89.6	90.5	90.6	89.6	88.1	86.3
500	83.9	84.6	85.1	84.3	84.4	84.8	85.1	86.6	88.4	88.8	89.1	89.5	90.3	89.4	87.3	86.2
630	82.7	84.8	85.3	84.3	83.2	83.8	84.2	85.5	87.3	87.8	89.0	89.9	90.7	89.2	86.3	85.0
800	82.7	85.2	85.8	84.8	83.7	83.7	84.5	85.7	87.3	88.3	89.2	90.3	91.5	90.0	86.0	84.7
1000	82.9	85.4	85.9	84.6	83.8	83.4	84.3	85.4	87.8	88.1	89.6	90.5	91.6	89.3	85.6	84.3
1250	83.6	86.5	86.8	85.7	84.5	83.5	84.1	86.0	87.8	88.6	90.1	90.7	92.5	89.6	86.0	83.7
1600	84.5	87.8	88.5	87.1	85.8	85.1	85.1	86.1	88.5	89.5	91.0	91.4	93.6	90.5	86.5	83.9
2000	87.0	90.5	91.9	91.2	89.5	88.0	86.4	88.3	90.8	91.8	93.3	93.8	96.4	91.7	88.0	85.1
2500	95.5	100.5	102.2	102.5	100.7	98.0	94.4	93.4	95.2	95.7	97.4	99.2	103.2	98.7	94.0	90.6
3150	86.2	90.4	90.9	90.5	89.0	87.9	86.0	88.2	89.9	91.9	92.9	95.0	96.7	93.9	88.2	85.0
4000	85.7	91.4	91.7	91.2	89.9	88.1	86.2	88.4	90.6	92.0	94.0	94.3	96.7	92.8	88.4	84.8
5000	87.0	94.7	97.7	97.5	95.7	92.5	90.2	88.8	89.7	90.5	93.8	94.0	97.5	93.0	89.3	85.8
6300	84.0	90.2	91.6	90.1	88.7	88.8	84.1	85.5	87.5	89.2	91.0	93.3	94.2	92.7	86.5	82.3
8000	82.2	91.6	91.8	92.0	91.1	90.3	85.0	85.6	87.9	89.4	91.1	91.4	94.1	90.6	87.0	81.9
10000	78.2	88.8	89.5	89.3	87.6	86.6	81.8	83.1	84.8	86.8	88.3	89.3	91.1	88.4	84.6	79.0

TABLE VI. - Concluded.

(d) 90 Percent of design speed.

FREQUENCY	ANGLE, DEG															
	10	20	30	40	50	60	70	80	90	100	110	120	130	140	150	160
	1/3-OCTAVE BAND SOUND PRESSURE LEVELS (SPL) ON 45.7 METER RADIUS															
50	61.0	76.3	77.0	81.9	79.3	83.1	80.6	77.8	81.6	81.3	81.5	82.9	83.3	84.8	86.3	87.5
63	76.8	77.8	76.9	75.8	76.6	76.6	77.4	76.4	79.4	78.1	79.9	81.5	85.3	85.4	87.3	88.2
80	79.3	81.1	79.1	75.1	76.4	75.9	76.3	77.1	80.3	79.9	81.8	83.2	85.4	87.3	89.3	90.3
100	85.6	85.6	83.6	83.0	82.6	83.1	81.0	82.5	83.5	84.5	85.8	87.6	89.0	90.1	91.1	91.5
125	86.2	86.8	86.5	85.3	84.7	85.2	85.2	86.2	86.8	87.5	89.2	89.6	90.8	91.2	91.8	90.6
160	85.0	86.5	86.1	85.3	85.6	87.3	87.3	88.3	88.6	89.3	89.8	90.7	91.0	90.0	90.0	90.7
200	85.0	87.0	85.3	83.5	84.3	84.3	84.2	85.5	86.0	86.3	87.0	88.1	89.3	89.7	90.0	89.7
250	83.4	85.9	85.2	84.9	85.6	86.2	86.6	87.7	89.7	90.6	91.6	92.3	92.6	93.1	92.4	90.8
315	84.7	86.2	86.7	87.1	87.7	87.9	88.9	90.1	91.2	91.9	92.6	92.8	92.6	92.1	91.6	90.5
400	85.8	87.1	87.6	87.3	87.3	88.4	89.4	90.4	91.8	93.6	95.1	95.2	94.9	92.6	91.9	90.7
500	87.1	88.5	87.6	87.8	89.5	89.3	90.0	91.5	92.1	93.5	93.8	94.2	95.8	93.5	92.3	90.8
630	86.8	88.2	87.8	87.8	87.7	88.5	89.5	90.8	92.2	93.2	94.0	94.8	95.8	92.8	91.0	90.0
800	86.5	88.3	88.5	88.3	87.7	88.5	89.5	90.5	92.2	93.7	94.8	95.6	96.2	93.7	90.8	89.7
1000	86.6	88.4	88.1	88.3	87.8	87.8	88.9	90.1	92.3	93.1	94.3	95.7	96.4	92.9	90.1	89.0
1250	86.8	89.0	89.0	88.3	87.7	88.2	89.0	90.5	92.7	93.7	94.8	95.9	97.3	93.7	90.5	88.6
1600	87.5	90.2	90.2	89.7	88.2	88.3	89.0	90.8	92.8	93.7	95.8	96.3	98.7	95.2	91.0	88.4
2000	88.8	91.3	92.0	91.0	90.0	89.7	89.7	91.7	94.0	94.8	97.2	97.1	99.8	95.7	91.8	88.7
2500	96.9	100.6	101.1	101.7	99.4	98.4	94.7	94.2	95.9	97.4	99.7	101.3	103.1	97.7	93.6	90.8
3150	94.0	98.0	98.4	94.0	96.7	95.9	92.5	93.2	94.7	96.7	98.7	100.8	102.4	99.6	94.6	90.8
4000	88.3	92.8	92.4	92.4	91.8	90.6	89.9	92.5	94.6	95.8	98.3	98.4	100.4	96.4	92.4	88.4
5000	88.3	94.5	96.9	95.5	93.9	92.2	90.2	91.5	93.3	94.5	97.3	97.0	99.5	94.9	91.7	88.1
6300	87.2	93.0	94.9	93.3	91.7	91.7	89.3	90.3	91.5	93.8	95.7	97.7	97.8	96.4	90.5	86.5
8000	84.4	93.3	93.1	93.8	91.8	91.5	87.5	90.1	92.3	93.6	95.5	96.0	97.6	93.6	90.8	86.0
10000	80.2	90.3	90.3	90.4	88.6	86.3	84.8	87.9	89.1	91.1	93.1	93.1	94.9	91.8	88.4	83.3

TABLE VII. - NOISE OF QF-1A CONFIGURATION 74 (INACTIVE 3/4-LENGTH STATOR,
ACTIVE INLET WITH RINGS, INACTIVE EXHAUST DUCT)

[Data adjusted for standard day of 25⁰ C and 70 percent relative humidity;
SPL re 2×10⁻⁵ N/m².]

(a) 60 Percent of design speed.

FREQUENCY	ANGLE, DEG															
	10	20	30	40	50	60	70	80	90	100	110	120	130	140	150	160
1/3-OCTAVE BAND SOUND PRESSURE LEVELS (SPL) ON 45.7 METER RADIUS																
50	66.7	66.5	67.5	67.0	65.2	65.4	66.5	66.5	68.7	69.0	69.7	69.1	69.9	72.4	73.9	74.4
63	65.3	68.7	65.5	64.2	67.2	67.7	66.3	66.2	68.5	67.5	68.0	69.2	70.5	72.3	73.5	75.2
80	67.5	70.3	67.3	65.2	65.5	65.5	64.5	65.3	66.7	67.5	69.7	70.9	73.0	74.2	75.7	76.7
100	72.7	73.4	72.7	71.9	70.4	70.9	70.5	69.5	70.2	71.7	72.7	73.8	75.2	76.0	76.7	77.4
125	73.5	75.7	75.7	74.7	73.2	73.2	71.8	72.2	73.2	74.3	75.8	75.8	75.8	76.0	77.2	76.9
160	74.4	76.1	75.2	73.2	72.1	71.9	72.9	72.1	73.9	73.7	74.2	75.1	75.4	75.9	75.1	75.6
200	74.0	76.7	74.4	70.9	69.7	70.0	70.2	70.2	71.0	71.7	72.9	73.6	74.0	74.0	75.0	74.9
250	74.8	76.8	74.8	74.5	71.5	72.2	72.3	73.8	74.8	75.7	76.8	77.1	77.2	76.3	75.8	74.9
315	75.2	76.7	74.8	74.8	73.2	73.5	73.5	74.3	75.0	76.0	76.7	77.4	76.3	76.0	76.2	74.7
400	73.6	75.6	75.2	73.1	71.4	73.2	73.2	73.9	75.4	76.7	77.4	78.0	78.2	77.1	75.6	74.3
500	73.8	75.8	74.3	72.6	71.5	72.3	73.3	74.0	75.0	76.1	76.6	77.1	78.3	78.0	75.3	74.0
630	71.5	74.2	72.7	71.7	70.9	71.4	72.4	73.4	75.0	76.2	77.0	78.1	78.9	78.9	75.4	73.4
800	70.1	72.1	71.1	70.9	70.4	71.6	72.7	73.4	74.9	76.6	77.6	79.2	80.6	80.4	76.2	74.1
1000	69.4	70.7	70.1	69.7	69.7	70.4	71.9	73.1	75.1	76.6	77.7	79.2	80.9	80.1	75.7	73.5
1250	69.1	70.6	70.0	69.1	69.6	70.3	72.3	73.9	76.6	77.8	79.3	80.2	82.5	80.5	77.1	73.7
1600	74.3	77.0	74.8	73.7	73.3	75.5	77.3	76.8	80.7	84.0	84.5	85.4	89.7	88.2	81.8	78.1
2000	78.9	81.7	79.4	78.2	77.5	80.3	81.3	79.2	85.2	88.9	88.9	89.6	95.2	94.5	87.4	83.3
2500	69.5	72.0	70.3	69.3	69.0	69.6	71.3	74.0	77.3	79.1	81.0	82.6	84.8	82.3	77.5	73.7
3150	73.5	77.2	75.3	73.5	71.5	71.1	72.8	76.1	79.0	81.5	83.5	85.6	87.7	85.8	79.8	75.7
4000	76.8	81.3	79.7	78.2	75.3	73.4	74.1	77.6	80.2	82.6	85.7	86.9	90.4	88.1	83.1	78.3
5000	74.9	80.4	80.8	77.6	73.7	70.7	71.5	74.9	77.7	79.4	82.5	83.5	86.5	84.4	79.4	74.0
6300	76.1	81.4	80.6	78.0	75.4	72.5	70.1	73.4	75.9	78.4	80.6	83.8	84.9	84.2	78.3	74.1
8000	74.9	83.6	82.1	81.0	78.1	74.6	69.8	72.9	76.1	78.1	80.1	81.1	84.7	81.9	78.1	73.1
10000	73.4	82.6	81.4	80.4	77.8	74.2	68.8	70.9	73.0	75.2	77.7	79.5	82.2	80.6	76.9	70.8

TABLE VII. - Continued.

(b) 70 Percent of design speed.

FREQUENCY	ANGLE, DEG															
	10	20	30	40	50	60	70	80	90	100	110	120	130	140	150	160
1/3-OCTAVE BAND SOUND PRESSURE LEVELS (SPL) ON 45.7 METER RADIUS																
50	68.7	69.2	70.4	70.2	69.7	69.7	70.9	71.5	72.0	72.7	73.2	74.5	75.0	76.0	77.9	79.4
63	67.2	70.5	69.8	69.3	69.0	69.2	70.0	69.7	70.0	70.5	72.7	73.6	75.5	77.2	78.8	80.9
80	71.9	75.5	72.9	72.2	72.5	69.7	69.5	69.7	70.7	71.9	74.2	75.3	77.4	79.2	81.5	82.9
100	75.5	77.3	76.7	75.7	74.5	74.5	73.5	73.2	74.8	75.8	77.3	78.9	80.2	81.0	82.8	82.5
125	77.5	81.5	81.2	79.9	78.2	77.7	77.9	77.0	78.9	79.4	81.4	82.1	82.4	82.4	83.4	81.8
160	77.0	79.5	78.7	77.8	76.7	77.7	77.5	77.5	79.2	79.7	80.0	80.9	81.3	80.8	80.5	79.9
200	77.2	79.9	76.9	74.7	75.2	74.9	75.1	75.2	75.9	76.1	77.4	78.0	79.6	79.9	80.4	79.3
250	76.4	79.8	76.6	76.1	76.8	77.3	77.1	78.1	79.8	81.1	82.1	82.7	82.6	81.6	81.4	80.1
315	75.3	78.6	76.8	77.5	77.8	77.8	78.5	79.5	80.0	81.3	82.0	82.6	82.0	81.3	80.8	79.5
400	74.5	77.3	77.6	77.1	77.1	78.1	78.5	79.3	81.0	82.0	83.3	83.5	83.5	82.1	81.5	80.2
500	75.3	78.3	78.0	77.8	77.8	78.2	79.3	80.2	81.2	82.3	82.8	83.4	83.8	83.5	81.0	79.9
630	74.1	77.3	76.6	76.3	76.4	77.6	78.3	79.4	80.6	82.1	82.9	83.9	84.9	83.6	80.8	78.8
800	72.7	75.6	75.6	76.1	77.1	77.1	78.4	79.2	80.7	81.9	82.9	84.2	85.6	83.9	80.2	78.8
1000	72.1	75.2	74.7	75.4	75.7	76.7	77.9	79.6	81.1	82.1	83.3	84.3	85.6	83.4	79.9	78.8
1250	71.5	74.0	74.2	74.0	75.3	76.3	78.2	79.8	82.0	82.8	84.2	85.1	86.5	83.5	80.7	78.6
1600	72.2	75.0	74.7	74.7	75.8	77.0	79.0	80.2	82.5	83.8	85.7	85.9	88.0	84.3	80.8	78.4
2000	79.3	84.1	81.2	79.5	80.7	81.4	81.9	85.4	88.4	90.4	94.6	96.4	96.9	94.8	90.6	85.7
2500	73.7	77.5	75.7	75.2	76.2	77.0	78.4	81.2	83.7	85.9	88.2	90.1	91.3	89.3	85.5	81.9
3150	74.2	77.9	76.0	75.0	75.4	76.5	78.5	81.3	83.3	85.7	87.2	89.1	90.2	87.7	82.3	79.1
4000	78.4	84.1	82.8	81.6	79.8	78.9	79.7	82.7	85.2	87.7	90.6	90.8	94.1	89.9	85.4	81.3
5000	75.6	82.1	81.6	79.4	77.4	76.1	77.7	80.2	82.7	84.6	87.4	88.0	90.7	87.1	83.4	78.5
6300	77.7	84.5	84.1	81.7	80.1	78.7	76.5	79.2	81.2	84.1	85.9	88.7	89.4	88.2	81.4	78.6
8000	75.7	85.1	83.3	82.3	80.1	77.9	75.6	78.9	81.2	83.9	85.7	85.9	88.7	85.5	81.6	77.6
10000	76.4	86.6	85.8	84.9	83.0	80.4	75.4	77.3	78.6	81.6	83.4	84.9	86.9	83.9	80.3	75.2

TABLE VII. - Continued.

(c) 80 Percent of design speed.

FREQUENCY	ANGLE, DEG															
	10	20	30	40	50	60	70	80	90	100	110	120	130	140	150	160
1/3-OCTAVE BAND SOUND PRESSURE LEVELS (SPL) ON 45.7 METER RADIUS																
50	81.0	73.8	79.6	76.8	80.8	80.5	80.1	78.1	77.3	77.6	77.3	77.5	79.0	81.0	81.8	83.5
63	72.1	73.3	72.3	71.9	71.8	72.4	72.6	72.9	73.9	73.9	76.4	76.9	78.9	80.6	82.6	84.2
80	74.5	75.3	73.0	71.5	71.8	72.8	72.5	72.5	74.5	75.7	78.2	78.9	81.5	82.7	85.7	86.4
100	79.3	79.8	79.1	77.8	77.6	78.1	77.5	78.1	79.6	80.8	82.1	82.7	84.3	85.8	86.6	86.4
125	80.7	83.2	83.0	81.0	80.4	81.5	80.2	82.2	82.9	84.2	86.0	85.6	86.0	86.4	87.4	86.4
160	80.3	81.8	82.2	81.0	81.0	83.0	82.5	83.3	83.8	85.2	85.2	85.6	85.3	85.2	85.2	85.4
200	80.3	82.0	80.1	79.0	79.8	80.0	79.6	80.5	81.3	81.6	82.6	83.2	84.8	85.5	85.6	84.9
250	79.1	81.3	80.6	80.6	81.4	82.4	83.3	84.1	86.1	87.4	87.8	88.4	88.1	88.1	87.8	86.5
315	79.3	81.1	81.4	82.8	83.1	83.8	84.1	85.3	86.1	87.4	88.1	88.5	87.8	87.8	87.1	86.1
400	79.3	81.0	82.0	81.5	82.1	84.5	84.5	85.8	87.0	88.5	89.6	90.0	89.3	88.8	88.0	87.2
500	79.8	81.6	81.9	82.1	83.1	84.1	85.8	86.9	88.3	88.6	88.6	89.0	89.8	88.9	87.8	86.3
630	78.5	81.1	81.3	82.0	82.0	83.0	84.5	85.5	86.8	88.0	89.0	89.7	90.8	88.5	86.6	85.4
800	78.0	80.0	80.7	81.7	81.7	83.0	84.7	85.5	87.2	88.0	89.2	90.3	91.0	88.9	86.4	85.3
1000	77.6	80.3	80.3	80.8	80.8	82.6	84.0	85.6	87.0	88.1	89.5	90.2	91.1	88.5	85.6	84.5
1250	76.1	78.4	78.7	79.4	80.2	81.9	84.1	85.6	87.6	88.9	89.9	91.0	92.2	88.9	85.7	83.8
1600	75.6	78.5	79.1	79.6	80.6	82.3	84.3	85.5	88.3	89.3	90.8	91.7	93.3	89.8	86.0	83.7
2000	79.5	80.1	80.0	80.5	81.4	83.5	85.5	87.2	90.2	91.7	93.2	94.0	95.4	90.9	87.2	84.6
2500	81.0	83.8	84.0	84.7	83.7	85.5	88.0	88.7	92.0	94.5	96.7	98.8	100.3	98.0	92.0	90.6
3150	77.6	80.4	79.4	79.8	80.8	82.3	84.4	87.4	89.8	91.9	92.9	94.7	95.8	92.9	87.9	84.7
4000	78.8	83.5	82.1	82.1	81.6	82.9	84.3	87.7	90.3	92.2	93.6	94.0	96.3	92.2	87.6	84.3
5000	79.6	86.5	86.8	86.7	83.6	82.5	83.8	86.3	89.0	90.6	93.3	94.1	96.6	92.3	88.8	83.8
6300	79.5	86.6	85.2	84.0	82.0	82.1	81.8	84.7	87.5	90.2	91.2	93.5	93.3	92.0	86.5	83.2
8000	79.3	88.2	86.9	86.8	84.4	84.1	81.9	85.5	88.0	90.0	91.4	91.9	93.7	90.2	87.2	82.6
10000	77.2	89.0	87.5	87.3	84.6	83.4	80.5	83.5	85.3	88.0	89.3	90.4	91.5	88.7	85.7	80.6

TABLE VII. - Concluded.

(d) 90 Percent of design speed.

FREQUENCY	ANGLE, DEG															
	10	20	30	40	50	60	70	80	90	100	110	120	130	140	150	160
	1/3-OCTAVE BAND SOUND PRESSURE LEVELS (SPL) ON 45.7 METER RADIUS															
50	77.9	76.4	77.0	80.7	77.2	84.2	78.7	78.2	79.5	80.4	81.5	82.8	83.0	83.2	85.4	87.1
63	73.6	76.4	75.7	76.1	75.1	76.7	75.7	76.1	76.7	77.7	79.7	80.5	82.1	84.6	86.9	88.0
80	77.5	79.7	77.2	75.0	75.7	76.2	75.7	76.2	78.3	79.3	81.3	82.2	84.7	86.7	89.0	90.5
100	83.6	84.2	82.9	82.4	81.9	83.4	82.4	82.6	83.6	84.6	86.1	86.1	88.4	89.7	90.9	90.8
125	84.0	86.4	85.9	84.5	84.7	84.9	85.0	85.9	86.2	88.2	88.9	89.4	90.2	90.9	91.7	89.9
160	83.6	84.9	85.9	85.1	85.2	87.1	86.7	87.1	88.1	88.9	89.6	90.0	89.7	89.7	90.1	89.4
200	84.2	86.3	84.7	82.8	83.3	83.8	83.5	84.5	85.5	86.0	86.7	87.8	88.8	89.5	89.5	89.1
250	81.7	84.8	84.3	84.7	85.2	86.3	86.7	87.3	89.3	90.8	91.3	92.3	92.0	92.5	92.3	91.2
315	82.1	84.8	85.8	87.3	86.8	88.1	88.4	89.3	90.1	91.8	92.6	92.4	92.3	91.8	91.3	90.5
400	82.8	85.0	85.8	86.0	86.1	88.3	88.6	90.0	91.8	93.1	94.5	95.2	94.1	92.6	92.5	91.0
500	83.5	85.8	86.3	87.0	88.3	89.1	90.0	91.3	92.5	93.0	93.6	94.0	95.1	93.1	92.8	90.8
630	82.8	85.8	86.3	86.8	86.9	88.4	89.3	90.6	91.9	92.9	93.8	94.5	95.8	92.9	91.6	90.5
800	82.2	85.1	85.6	86.3	86.7	88.6	89.8	90.4	92.3	93.4	94.6	95.3	96.3	93.3	91.3	90.3
1000	81.6	84.6	85.2	85.7	85.7	87.7	89.2	90.4	92.1	93.4	94.2	95.5	96.4	92.2	90.7	89.6
1250	80.1	83.1	83.8	84.5	85.3	87.1	89.0	90.5	92.6	94.0	95.3	95.6	97.1	92.7	90.6	88.7
1600	79.6	82.8	83.5	84.5	85.6	87.1	89.3	90.5	92.8	94.1	95.6	96.4	98.3	94.5	91.0	88.5
2000	79.7	82.6	83.9	84.9	86.2	88.1	89.5	91.6	93.9	95.2	96.9	97.3	99.4	95.1	91.6	88.8
2500	84.4	87.1	86.7	86.6	87.6	88.2	89.9	92.4	95.9	97.4	99.9	101.5	102.2	97.4	92.4	90.1
3150	82.3	85.1	84.4	85.3	86.1	87.8	89.6	92.6	94.9	97.1	98.6	100.9	101.3	98.4	93.6	90.2
4000	81.1	86.1	84.9	85.3	86.4	88.0	89.7	92.7	94.8	96.7	98.5	98.6	100.2	96.0	92.8	88.9
5000	82.9	88.9	89.6	87.8	86.3	86.9	89.1	91.2	93.6	95.2	97.1	97.6	98.9	94.9	92.3	87.1
6300	81.9	87.9	87.7	86.8	85.3	87.4	87.4	90.3	92.2	94.3	96.1	98.3	97.7	96.3	91.3	87.8
8000	80.8	90.3	88.8	88.7	87.0	88.1	86.9	90.5	92.6	95.0	95.8	96.1	97.4	93.9	91.3	87.2
10000	78.4	89.7	88.4	88.4	86.2	87.0	85.5	88.8	90.1	92.4	94.1	94.7	95.6	92.3	90.1	84.9

TABLE VIII. - NOISE OF QF-1A CONFIGURATION 75 (INACTIVE SHORT STATOR, ACTIVE
INLET WITH RINGS, INACTIVE EXHAUST DUCT)

[Data adjusted for standard day of 25⁰ C and 70 percent relative humidity;
SPL re 2×10⁻⁵ N/m².]

(a) 60 Percent of design speed.

FREQUENCY	ANGLE, DEG															
	10	20	30	40	50	60	70	80	90	100	110	120	130	140	150	160
	1/3-OCTAVE BAND SOUND PRESSURE LEVELS (SPL) ON 45.7 METER RADIUS															
50	72.0	71.2	69.5	76.9	71.9	69.5	73.0	74.5	79.4	73.2	75.9	76.3	73.2	73.4	73.9	78.4
63	69.4	69.7	67.4	76.0	72.2	68.9	71.9	73.7	79.0	70.0	72.7	74.0	80.0	73.7	75.4	81.9
80	71.5	72.0	69.5	74.9	70.4	68.2	71.4	71.7	76.9	69.4	72.0	73.3	74.9	74.7	76.7	77.9
100	76.0	75.5	75.4	75.2	73.4	72.4	72.2	72.9	76.5	71.0	74.7	75.5	76.0	76.7	78.2	78.1
125	78.9	79.8	78.8	78.1	76.6	74.8	75.1	73.9	75.9	75.4	76.6	77.5	77.9	77.6	78.8	78.5
160	80.0	80.5	79.0	77.7	76.5	75.4	76.7	75.2	77.0	76.2	77.2	78.3	77.2	77.9	77.9	77.7
200	79.0	79.7	77.9	75.2	74.2	73.7	74.4	74.0	75.4	75.5	76.2	77.0	78.2	76.9	77.7	77.1
250	80.6	81.3	79.3	77.1	76.3	75.3	75.9	76.6	80.1	80.6	82.9	82.4	82.1	80.3	78.3	76.6
315	80.7	79.7	78.2	77.7	77.5	76.8	77.2	77.2	80.3	80.5	82.0	82.6	81.5	79.3	78.5	76.9
400	78.1	77.3	77.3	76.6	75.5	75.6	76.5	77.6	80.0	81.6	82.6	83.4	82.8	81.1	78.1	76.2
500	78.1	77.6	76.5	74.8	74.1	75.5	76.3	77.3	80.6	82.0	83.1	83.9	82.8	80.5	77.8	76.2
630	76.4	76.3	74.8	73.8	72.8	73.6	74.8	75.8	77.9	80.3	81.1	81.7	81.8	80.6	77.4	75.8
800	73.7	73.9	73.1	72.9	72.2	72.9	74.4	76.1	77.4	80.4	81.7	82.2	82.7	81.9	76.7	75.1
1000	71.8	71.3	71.0	71.3	71.0	72.0	73.5	74.8	77.3	79.3	80.8	82.1	82.3	81.5	76.2	74.6
1250	71.7	70.9	70.7	70.4	70.2	71.7	73.5	75.2	77.5	79.4	81.9	82.8	83.4	82.0	77.4	74.4
1600	78.1	77.4	75.1	73.2	73.1	73.6	75.9	77.4	80.9	82.6	85.1	86.2	89.2	86.9	81.9	77.6
2000	83.5	85.0	81.5	79.0	79.2	78.2	80.7	81.8	86.8	88.5	91.7	92.8	96.5	96.0	90.7	85.2
2500	73.1	72.2	71.2	70.6	70.4	70.9	72.9	75.4	78.7	81.6	83.2	85.0	86.7	84.0	78.9	75.4
3150	77.8	76.1	74.1	72.8	71.8	72.0	73.3	77.1	79.5	83.1	84.3	86.4	87.6	85.8	80.5	76.7
4000	82.2	81.4	80.0	78.7	75.5	74.1	75.1	78.3	81.1	83.8	86.8	87.9	91.0	89.8	84.2	79.0
5000	80.1	79.6	78.3	77.3	73.0	71.1	72.3	75.8	78.5	80.8	84.0	84.1	87.3	84.8	80.8	75.2
6300	82.1	81.6	80.1	78.4	75.2	73.3	70.8	74.5	77.0	81.3	81.6	84.8	85.8	84.1	79.5	76.2
8000	81.7	82.5	82.2	80.0	77.2	73.5	70.3	74.0	77.2	79.2	80.8	82.1	85.0	83.5	79.2	73.3
10000	81.0	81.4	81.2	79.7	77.9	73.8	69.5	71.5	74.0	77.0	78.7	80.2	82.4	80.7	77.5	71.5

TABLE VIII. - Continued.

(b) 70 Percent of design speed.

FREQUENCY	ANGLE, DEG															
	10	20	30	40	50	60	70	80	90	100	110	120	130	140	150	160
	1/3-OCTAVE BAND SOUND PRESSURE LEVELS (SPL) ON 45.7 METER RADIUS															
50	74.7	72.9	73.9	72.6	72.6	72.6	73.9	74.7	75.6	76.1	75.6	76.8	76.1	77.9	79.2	80.3
63	72.5	72.9	72.9	72.0	71.9	72.9	73.9	73.2	72.2	73.7	74.4	75.6	81.7	78.5	79.4	82.9
80	76.6	76.9	74.2	72.1	72.1	71.9	73.1	72.7	71.9	73.9	74.7	76.7	78.2	79.9	81.7	82.5
100	80.7	80.4	78.4	77.2	75.7	76.4	75.1	75.9	77.1	77.1	78.1	79.0	81.2	81.9	83.4	83.3
125	83.1	83.6	82.6	81.1	80.3	80.4	80.1	78.1	80.6	81.3	82.6	83.4	83.3	84.1	84.8	83.6
160	84.2	84.9	83.7	84.1	81.1	81.4	81.7	81.9	83.2	83.1	84.4	84.7	84.1	84.6	84.2	84.1
200	83.7	84.2	81.4	79.6	79.9	80.1	79.7	81.2	81.1	81.9	82.9	83.5	84.9	84.1	83.4	82.8
250	82.0	84.0	82.2	80.5	81.3	81.2	82.7	84.0	85.8	87.8	89.0	89.3	89.2	86.8	84.0	82.0
315	81.0	81.3	81.5	81.7	83.0	83.2	83.7	85.0	86.8	88.3	89.3	88.9	88.2	86.0	84.3	83.4
400	79.6	80.6	80.3	80.3	80.5	81.5	83.0	84.6	86.5	88.0	89.3	90.5	89.6	87.3	83.8	82.0
500	79.6	80.3	79.8	78.5	80.1	81.5	83.0	84.3	87.0	89.0	90.0	91.0	90.0	87.1	84.1	83.0
630	78.2	79.2	78.2	78.2	78.6	79.7	81.7	82.9	85.1	87.6	88.4	88.8	88.6	87.1	83.1	81.6
800	76.2	77.2	77.2	77.5	78.0	78.8	81.2	82.5	84.2	86.8	88.5	88.8	89.0	87.3	82.8	80.9
1000	75.6	76.1	76.1	76.2	76.6	77.7	79.6	81.2	83.9	86.1	87.2	88.8	88.4	86.6	81.6	80.3
1250	74.6	75.3	75.4	75.3	75.8	76.9	79.9	81.8	84.1	85.9	87.9	89.2	88.6	86.1	81.9	80.0
1600	75.8	76.1	75.7	75.9	77.2	77.6	80.7	82.2	85.2	86.9	88.8	89.5	90.4	86.6	82.7	80.0
2000	82.2	83.1	81.7	80.2	81.1	81.9	84.0	86.2	89.6	91.4	96.1	95.8	98.9	95.1	89.2	86.5
2500	78.9	79.6	78.4	77.7	78.6	79.2	81.4	83.9	87.1	89.7	92.4	93.2	95.7	92.9	88.2	85.3
3150	78.8	78.2	76.7	75.7	76.5	77.3	79.5	82.8	85.8	88.8	89.8	91.6	92.2	88.8	84.0	81.4
4000	83.0	83.4	82.4	81.2	79.4	78.5	80.5	84.1	86.5	88.8	91.3	92.1	94.5	91.9	86.4	82.1
5000	81.6	82.0	81.1	80.5	77.3	76.6	78.8	81.6	85.0	87.0	89.6	90.1	93.0	90.5	85.8	80.6
6300	84.9	85.2	83.6	82.6	80.1	79.4	77.4	80.2	82.9	86.9	87.7	90.7	90.7	87.7	83.5	81.0
8000	83.1	84.4	84.3	82.3	79.5	77.6	75.9	80.1	83.3	85.4	87.1	88.2	90.6	87.8	83.6	78.6
10000	83.6	85.1	85.1	84.2	81.3	78.7	75.2	78.0	80.0	83.2	84.9	86.2	87.5	84.5	81.4	77.1

TABLE VIII. - Continued.

(c) 80 Percent of design speed.

FREQUENCY	ANGLE, DEG															
	10	20	30	40	50	60	70	80	90	100	110	120	130	140	150	160
	1/3-OCTAVE BAND SOUND PRESSURE LEVELS (SPL) ON 45.7 METER RADIUS															
50	81.8	78.5	79.5	82.3	79.8	82.5	78.5	80.0	78.8	80.0	78.8	80.5	80.0	81.8	81.8	83.6
63	73.8	74.5	74.8	74.0	74.0	74.8	75.0	76.0	76.8	78.0	77.0	77.8	82.5	81.0	82.8	85.2
80	77.0	77.0	75.3	73.5	73.5	74.3	74.0	75.5	75.8	77.3	77.8	79.8	81.5	83.3	84.8	85.9
100	83.1	80.8	80.1	79.8	78.6	79.8	78.8	79.3	80.6	81.3	82.1	83.1	85.1	85.8	87.1	87.5
125	83.0	83.0	82.0	82.0	82.0	82.8	82.0	83.0	84.3	85.8	86.3	87.0	87.3	87.8	88.5	87.4
160	81.8	82.8	83.3	82.3	82.0	85.5	85.3	86.3	87.5	88.5	89.3	89.3	88.5	88.3	87.8	87.9
200	82.8	84.3	84.0	82.5	83.0	84.5	83.8	86.0	85.8	85.8	87.0	87.5	87.8	87.5	87.5	87.2
250	82.0	83.5	83.8	83.5	84.5	85.3	86.5	88.0	89.3	91.0	92.3	92.5	92.5	90.8	88.8	86.4
315	82.0	83.5	85.0	85.0	86.5	87.5	88.2	90.0	91.2	92.7	93.5	93.7	92.0	90.5	88.2	87.6
400	81.5	83.0	84.8	85.5	84.8	87.3	88.5	90.3	91.8	93.3	94.0	94.8	94.3	90.8	88.5	87.4
500	82.3	83.0	83.3	83.0	84.8	85.8	87.5	89.8	91.8	93.0	94.0	94.8	93.8	91.3	89.0	87.7
630	81.4	82.4	82.9	83.2	82.9	84.9	87.4	88.4	90.7	92.7	94.2	94.2	94.2	91.9	88.4	86.6
800	80.3	81.5	82.0	83.0	83.0	83.8	86.5	88.3	89.8	91.8	94.0	95.3	95.0	91.8	87.8	86.1
1000	79.6	80.6	81.4	82.4	81.6	83.4	85.9	87.6	89.9	91.1	92.9	95.4	94.4	90.9	86.6	85.8
1250	78.7	79.5	80.2	80.7	81.0	82.7	85.5	87.2	90.0	91.5	94.0	95.7	94.7	90.7	87.7	85.3
1600	78.6	79.6	80.1	80.9	81.6	82.9	85.9	87.6	90.6	91.9	94.4	95.7	95.6	92.1	88.4	85.3
2000	80.0	80.3	81.0	82.0	82.3	84.3	86.8	89.0	91.8	94.0	96.0	97.0	97.3	93.5	89.5	86.4
2500	84.5	85.0	86.0	84.7	84.2	85.5	87.2	90.2	93.2	95.5	98.2	102.3	103.0	100.0	95.0	90.6
3150	81.9	81.4	80.7	80.7	81.4	83.4	85.2	88.7	91.4	93.9	95.4	98.2	98.2	94.7	90.2	87.6
4000	83.8	83.3	83.1	82.9	82.1	83.2	85.4	88.9	91.4	93.2	95.9	97.0	98.1	94.2	89.6	85.8
5000	86.0	85.8	87.5	87.5	84.0	82.8	85.0	87.5	90.2	92.0	95.0	96.0	98.3	94.3	90.8	85.7
6300	86.5	86.5	85.2	84.0	82.0	83.0	83.0	86.0	88.2	92.0	92.2	95.8	95.2	91.5	87.7	85.4
8000	87.2	88.2	88.5	86.7	85.2	83.0	82.4	86.2	88.9	91.2	92.4	93.7	95.7	92.2	88.2	83.6
10000	66.1	87.1	87.6	86.3	84.1	82.0	81.1	84.1	85.8	89.1	90.1	91.9	92.8	89.3	86.3	81.8

TABLE VIII. - Concluded.

(d) 90 Percent of design speed.

FREQUENCY	ANGLE, DEG															
	10	20	30	40	50	60	70	80	90	100	110	120	130	140	150	160
1/3-OCTAVE BAND SOUND PRESSURE LEVELS (SPL) ON 45.7 METER RADIUS																
50	77.8	76.1	77.3	80.3	77.8	81.3	78.6	79.0	79.8	79.6	81.0	81.6	81.3	82.6	85.0	86.4
63	75.9	77.0	76.4	76.5	76.0	76.7	76.9	76.7	77.9	77.9	79.7	80.8	84.2	83.5	85.4	87.6
80	79.0	80.5	77.9	75.9	75.2	75.5	75.9	77.2	77.7	79.0	81.2	82.1	84.9	86.4	88.0	89.4
100	86.1	85.2	84.2	84.4	83.6	83.7	81.1	84.1	84.4	83.4	86.9	86.7	87.9	89.7	91.1	90.5
125	86.2	86.0	85.7	83.9	83.9	83.7	83.5	85.4	85.9	87.5	88.5	90.0	90.2	91.0	92.4	91.4
160	84.0	85.2	85.7	84.5	84.5	87.5	87.9	89.2	89.4	90.7	90.9	91.9	91.5	90.4	89.9	90.6
200	85.2	86.7	86.2	83.7	84.2	85.5	85.9	87.0	87.2	87.4	88.4	89.8	89.7	89.4	89.5	89.1
250	84.0	85.3	85.6	85.0	86.3	87.1	88.5	89.0	91.6	93.0	94.3	94.7	95.0	93.0	91.5	89.7
315	84.1	85.3	86.8	87.1	88.4	89.4	90.6	91.8	93.8	94.8	95.3	95.5	93.9	91.9	90.9	90.6
400	83.8	85.0	86.5	87.7	87.7	89.5	90.2	91.5	93.2	94.7	95.7	96.8	95.5	93.0	91.3	90.1
500	84.9	85.9	86.0	86.4	87.9	89.7	90.9	92.5	93.7	94.9	95.7	96.5	96.0	93.0	91.5	90.4
630	84.7	85.4	85.7	86.5	86.5	89.0	91.5	92.4	94.0	95.9	96.4	97.5	97.0	93.7	91.4	89.8
800	84.1	85.1	85.6	86.7	86.6	88.1	90.7	92.4	93.2	94.9	97.4	98.8	98.6	94.7	91.2	89.9
1000	83.5	84.4	85.2	86.2	86.2	88.4	90.5	92.0	94.0	95.9	97.9	99.6	98.7	94.4	90.9	90.1
1250	82.8	83.1	84.1	85.1	85.4	87.3	90.1	91.8	94.3	96.3	98.8	100.0	99.3	94.8	91.3	90.0
1600	82.3	83.3	83.6	85.0	86.1	87.6	90.0	92.0	94.5	96.6	98.5	99.2	99.8	95.5	91.5	89.5
2000	82.5	83.0	84.5	85.4	86.5	88.3	90.8	92.5	95.4	97.0	99.4	99.6	100.9	95.9	92.5	89.9
2500	86.9	86.9	86.1	86.6	87.4	88.4	90.6	93.1	96.2	98.9	100.6	102.3	103.1	97.9	93.7	90.6
3150	87.8	87.3	86.3	86.8	87.5	88.3	90.1	93.1	95.8	99.0	100.6	102.7	103.6	99.6	95.1	92.2
4000	86.4	85.9	85.9	85.9	85.7	87.5	90.3	93.3	95.8	97.7	100.3	100.6	101.7	97.3	93.3	90.1
5000	89.2	88.0	88.0	87.5	85.5	86.3	89.1	92.1	94.8	96.3	99.0	99.3	100.5	95.8	93.0	88.6
6300	89.9	89.2	88.4	87.4	85.9	88.0	87.7	90.7	92.9	97.0	97.2	100.0	99.4	95.2	91.7	89.6
8000	88.9	89.9	89.6	88.4	85.9	86.7	86.9	90.7	93.6	95.6	97.1	97.4	98.9	95.6	91.7	87.2
10000	87.5	88.4	88.3	87.4	84.8	85.2	85.8	89.0	91.0	93.7	95.2	95.8	96.5	92.5	90.0	86.0

TABLE IX. - NOISE OF QF-1A CONFIGURATION 76 (INACTIVE SHORT STATOR,
INACTIVE INLET WITH RINGS, INACTIVE EXHAUST DUCT)

[Data adjusted for standard day of 25⁰ C and 70 percent relative humidity;
SPL re 2×10⁻⁵ N/m².]

(a) 60 Percent of design speed.

FREQUENCY	ANGLE, DEG															
	10	20	30	40	50	60	70	80	90	100	110	120	130	140	150	160
	1/3-OCTAVE BAND SOUND PRESSURE LEVELS (SPL) ON 45.7 METER RADIUS															
50	71.7	68.2	68.8	69.0	68.3	68.3	68.0	69.3	69.8	69.5	70.3	69.9	72.2	71.8	73.5	74.9
63	68.7	68.5	66.9	66.5	67.2	68.5	67.0	68.4	69.0	67.4	68.5	69.3	77.5	72.5	73.9	74.7
80	71.0	72.8	69.3	68.0	67.8	67.8	65.1	67.3	68.8	67.8	70.0	71.1	72.5	74.6	75.6	76.7
100	77.1	77.1	76.0	75.3	74.8	72.6	72.5	71.8	72.0	72.0	73.8	74.2	75.1	76.8	77.5	77.3
125	80.4	82.0	80.0	78.9	78.9	75.9	75.4	74.5	75.9	75.5	76.5	77.6	78.0	78.2	80.4	78.3
160	83.2	84.0	81.5	79.2	78.5	75.4	77.4	75.0	77.5	77.0	78.4	79.4	78.5	78.5	78.7	77.4
200	81.8	82.3	79.3	76.3	75.3	73.8	73.6	74.0	75.1	75.5	77.3	77.7	78.8	78.1	78.0	76.5
250	82.6	83.0	81.1	79.3	78.1	77.5	76.6	78.1	79.6	81.3	82.5	83.0	82.6	81.0	79.0	76.7
315	83.1	82.8	80.1	79.8	78.6	77.9	77.8	78.4	80.1	80.9	82.3	82.5	82.1	80.3	79.4	76.6
400	81.9	81.2	80.6	78.2	77.4	77.1	76.9	78.9	80.6	81.4	83.6	84.3	83.7	81.9	78.9	76.5
500	83.1	82.8	80.8	78.8	76.3	76.9	76.9	78.6	79.9	82.1	83.8	84.7	83.3	81.6	78.9	76.8
630	82.5	82.7	80.2	78.5	76.2	75.2	75.4	77.4	78.4	81.2	82.9	83.1	82.4	82.0	78.0	76.1
800	80.8	81.9	80.3	79.3	76.6	76.1	75.9	77.6	77.8	80.3	82.8	83.3	83.3	82.9	78.3	75.3
1000	81.7	81.5	80.2	78.7	77.4	75.2	75.2	75.9	77.4	79.7	82.0	82.8	82.9	82.4	77.7	75.3
1250	81.7	82.7	81.7	79.7	78.4	75.7	75.4	77.2	77.9	79.7	82.6	83.5	83.7	82.7	79.1	75.1
1600	87.8	89.6	88.1	87.1	86.8	83.0	80.5	81.0	83.0	84.1	86.5	87.9	90.6	88.1	83.5	79.2
2000	93.0	96.0	94.5	93.8	93.1	89.8	86.0	85.6	88.3	88.5	91.1	93.2	96.6	94.8	89.8	86.0
2500	84.1	84.7	84.9	83.6	81.6	79.1	76.9	78.1	80.2	82.1	83.9	85.7	86.4	84.7	80.2	76.5
3150	85.7	86.7	85.8	85.3	83.7	80.7	77.8	78.8	80.8	83.5	85.3	87.3	88.0	86.5	81.2	77.7
4000	88.6	90.5	89.4	89.7	88.0	84.3	80.1	80.5	82.0	83.8	86.8	88.4	90.6	89.3	84.0	79.2
5000	84.1	85.3	86.5	85.4	82.2	79.3	76.4	77.5	79.1	81.1	84.3	85.1	86.9	84.9	81.1	75.9
6300	84.8	85.1	84.6	83.6	81.6	79.8	74.6	75.6	77.3	80.9	81.9	84.9	84.8	83.9	79.3	76.2
8000	83.1	84.5	84.0	83.8	81.5	78.8	73.5	75.0	77.5	78.8	81.3	82.6	84.6	83.1	78.5	73.1
10000	80.6	81.7	81.6	81.1	78.8	76.6	71.3	72.3	74.1	76.4	78.8	80.1	81.6	79.7	76.6	71.1

TABLE IX. - Continued.

(b) 70 Percent of design speed.

FREQUENCY	ANGLE, DEG															
	10	20	30	40	50	60	70	80	90	100	110	120	130	140	150	160
1/3-OCTAVE BAND SOUND PRESSURE LEVELS (SPL) ON 45.7 METER RADIUS																
50	74.8	71.1	72.9	71.9	70.3	71.1	71.4	72.9	74.6	74.6	75.6	74.2	76.3	75.4	77.1	79.1
63	71.7	73.1	70.2	70.9	70.6	69.9	70.2	70.9	71.2	72.4	73.9	74.0	79.6	77.2	78.4	79.0
80	77.1	77.6	74.6	72.4	72.4	71.3	71.9	72.4	72.3	73.3	74.8	75.9	79.3	78.9	81.1	82.3
100	81.8	81.6	79.3	78.6	76.8	76.3	75.0	75.1	76.5	77.3	78.3	79.0	81.5	81.6	83.5	83.3
125	83.9	84.9	83.2	82.4	80.1	79.7	79.6	78.2	80.7	81.4	83.1	83.2	83.7	84.2	84.2	83.6
160	86.9	87.8	84.9	83.3	82.1	81.8	81.9	81.4	82.9	82.9	84.4	85.0	84.3	84.9	83.9	83.3
200	85.9	86.1	83.1	80.9	80.4	79.4	78.9	80.1	80.4	81.6	82.9	83.6	83.9	83.6	82.7	81.6
250	84.0	85.0	83.3	82.0	82.1	81.5	82.3	83.3	85.5	87.0	87.8	88.4	88.1	86.1	83.8	81.5
315	82.5	83.1	82.8	83.1	82.6	82.6	82.5	84.0	85.8	87.3	88.6	88.4	87.6	85.3	84.1	82.2
400	82.9	82.7	83.0	81.4	80.9	81.5	82.9	84.4	86.7	87.7	89.7	90.1	89.4	86.9	83.9	82.1
500	84.7	84.2	83.4	81.7	80.9	81.4	82.7	84.0	86.4	88.0	89.2	90.0	89.9	86.9	84.0	82.1
630	82.9	83.2	82.7	81.1	80.4	80.2	81.6	82.9	84.9	87.1	88.4	88.5	88.4	86.4	83.1	81.3
800	82.6	83.3	82.6	81.8	80.5	79.6	81.1	82.8	84.8	86.8	88.5	88.9	88.8	86.8	83.0	80.7
1000	82.9	83.0	82.7	82.0	80.4	79.4	80.7	82.0	84.4	85.9	87.5	88.5	88.9	86.0	81.5	80.1
1250	82.9	84.1	83.6	82.2	81.1	79.2	80.6	81.9	84.4	85.4	87.9	88.8	89.2	86.1	82.1	79.6
1600	84.9	86.2	85.8	84.1	83.0	80.6	81.6	82.7	85.4	86.2	88.9	89.5	90.6	86.7	82.6	80.0
2000	95.1	96.6	98.9	99.0	95.4	93.6	90.1	88.1	90.4	91.1	95.6	96.2	100.3	95.6	91.3	87.3
2500	89.2	90.5	92.0	91.7	88.8	86.8	84.2	84.5	86.7	88.3	91.0	92.3	95.3	91.8	87.3	83.9
3150	86.8	87.8	87.6	86.8	86.1	83.5	81.8	83.5	85.6	88.1	90.0	91.6	92.3	89.0	84.3	81.4
4000	89.9	92.0	93.3	93.0	91.3	88.6	86.0	85.6	86.9	88.2	92.1	92.3	94.7	91.7	86.5	82.2
5000	86.3	87.8	89.6	88.4	86.3	83.5	82.1	82.4	84.9	86.1	89.4	89.8	92.1	88.8	85.5	80.1
6300	88.2	89.4	89.2	88.4	87.5	86.9	81.2	81.3	82.8	86.4	87.7	90.5	90.5	87.8	83.2	80.3
8000	85.5	87.8	87.3	87.2	85.0	82.9	78.8	80.3	82.8	84.5	86.8	88.0	89.8	86.8	83.0	77.6
10000	83.7	85.8	85.9	85.3	83.7	81.0	77.2	78.0	79.7	82.0	84.7	85.9	86.7	83.5	80.5	75.5

TABLE IX. - Continued.

(c) 80 Percent of design speed.

FREQUENCY	ANGLE, DEG															
	10	20	30	40	50	60	70	80	90	100	110	120	130	140	150	160
1/3-OCTAVE BAND SOUND PRESSURE LEVELS (SPL) ON 45.7 METER RADIUS																
50	81.4	74.4	80.7	79.7	82.1	79.9	82.2	78.7	80.6	81.6	80.4	81.2	80.9	81.6	81.9	82.3
63	73.9	75.1	73.4	73.1	73.9	73.3	73.9	74.6	74.9	76.1	76.6	78.2	81.8	80.8	81.6	83.8
80	77.8	78.6	76.3	73.6	74.3	74.4	74.6	74.9	76.3	78.1	78.8	79.8	81.8	83.4	85.4	86.1
100	83.1	81.9	80.9	80.2	79.9	79.6	78.7	79.7	81.9	82.1	82.4	83.7	85.1	86.6	87.7	87.6
125	83.6	83.6	83.1	82.6	82.2	82.1	82.2	83.2	84.1	85.4	86.7	87.0	87.6	87.9	88.6	87.0
160	82.4	82.9	82.9	82.4	82.2	85.1	85.4	86.1	87.2	87.9	88.2	89.0	88.7	88.2	86.9	86.4
200	83.9	85.2	83.0	82.2	83.0	82.7	83.2	84.9	84.9	86.0	86.9	87.5	87.5	87.4	87.0	86.1
250	83.2	84.3	84.0	83.7	85.3	85.7	86.5	88.3	89.5	91.3	93.0	92.4	92.5	90.5	88.2	86.4
315	83.1	84.3	84.6	85.5	86.6	87.1	87.3	89.3	91.1	92.6	93.5	92.9	92.0	89.6	88.3	86.7
400	84.0	84.1	85.1	85.0	84.8	86.8	88.5	90.1	91.6	93.0	93.8	94.2	93.6	90.8	88.6	86.9
500	84.7	85.2	84.6	84.4	85.2	86.7	87.4	89.9	91.4	93.1	93.9	94.2	94.1	90.9	88.9	86.9
630	84.7	85.2	84.9	84.5	84.4	85.7	87.2	88.9	91.0	92.5	93.5	94.3	94.2	91.5	88.4	86.3
800	84.7	85.3	85.3	85.2	85.0	85.3	86.5	88.3	89.8	92.2	94.2	95.6	95.0	91.8	87.8	85.9
1000	84.9	85.9	85.7	85.2	84.4	85.1	86.4	88.1	89.7	91.2	93.9	95.5	94.4	90.6	87.1	85.4
1250	85.4	86.2	86.4	85.6	84.7	84.9	86.1	87.7	90.2	91.2	93.9	95.5	94.6	90.9	87.9	85.3
1600	86.7	87.8	87.7	86.7	86.2	85.2	86.7	88.2	90.7	91.8	94.7	95.8	95.3	91.3	88.2	84.9
2000	88.6	89.9	91.1	90.6	89.1	88.6	88.1	89.9	92.1	93.9	96.4	96.9	97.3	92.9	89.3	86.0
2500	97.5	100.1	101.6	102.6	100.6	98.8	95.9	94.1	94.4	96.6	98.9	102.1	103.3	100.0	94.3	90.4
3150	89.1	90.5	90.6	89.9	88.6	88.1	86.6	89.5	91.3	94.1	95.8	97.7	97.6	94.1	89.8	86.5
4000	89.8	90.9	91.3	91.1	89.1	87.6	86.8	89.7	91.7	93.4	96.2	97.0	97.4	93.9	89.6	85.6
5000	91.7	94.0	96.8	97.3	94.5	92.2	90.3	89.2	91.2	92.3	95.3	96.1	97.8	93.3	90.5	85.5
6300	89.8	90.7	90.6	90.0	87.8	88.0	84.6	87.0	88.7	92.2	92.8	95.8	94.7	91.3	87.5	85.0
8000	89.3	91.3	91.3	92.0	90.2	89.3	85.5	86.6	89.1	90.6	92.5	93.8	94.8	91.1	88.1	82.9
10000	87.1	88.5	89.0	88.8	86.8	85.9	82.8	84.5	86.0	88.1	90.1	91.5	92.0	88.1	85.8	80.7

TABLE IX. - Concluded.

(d) 90 Percent of design speed.

FREQUENCY	ANGLE, DEG															
	10	20	30	40	50	60	70	80	90	100	110	120	130	140	150	160
	1/3-OCTAVE BAND SOUND PRESSURE LEVELS (SPL) ON 45.7 METER RADIUS															
50	79.9	75.4	77.7	62.2	79.2	82.5	81.0	79.2	81.9	81.7	83.0	83.6	83.0	84.0	85.7	87.1
63	77.6	78.1	77.8	76.9	77.9	77.8	78.4	77.9	78.3	79.8	80.8	82.2	84.6	84.4	85.8	87.6
80	81.3	81.8	79.3	77.6	77.8	77.9	78.4	78.3	79.1	81.4	83.1	84.0	85.8	87.1	89.3	90.8
100	88.4	88.2	85.9	85.9	86.4	85.4	82.0	85.4	86.4	85.5	89.0	89.8	89.5	90.4	92.9	91.6
125	87.2	87.4	86.6	85.6	85.4	85.7	84.6	86.4	87.4	88.4	90.2	90.8	91.7	92.1	93.2	91.1
160	85.6	87.1	87.2	85.9	86.1	88.2	88.1	89.6	90.2	91.1	91.7	92.8	92.1	91.4	91.7	90.8
200	87.9	88.8	86.9	85.1	85.8	86.1	85.8	87.8	87.8	88.1	89.3	90.4	90.8	89.8	90.6	89.8
250	85.1	86.9	86.5	86.8	87.8	87.8	87.8	89.6	91.5	92.8	94.1	94.5	95.0	93.3	92.0	90.3
315	86.3	87.0	87.5	88.1	89.1	89.5	89.6	92.0	93.3	94.6	95.0	95.0	94.3	93.0	92.1	91.0
400	87.0	88.4	89.4	88.7	88.7	90.5	91.2	91.7	93.2	94.5	96.0	96.3	95.9	92.9	91.5	89.9
500	87.8	88.5	88.0	88.3	89.6	89.8	90.6	92.1	93.5	95.1	95.8	96.2	96.3	93.1	91.5	89.8
630	88.0	88.7	88.4	88.5	88.0	89.7	90.5	92.0	93.5	95.7	96.5	97.0	97.4	93.9	91.5	90.3
800	88.3	88.9	88.6	89.3	88.9	89.1	90.3	91.9	93.4	95.1	96.8	98.9	98.8	94.4	91.3	90.2
1000	88.0	89.2	89.0	89.5	88.9	89.5	90.2	92.0	94.2	95.5	97.7	99.5	98.4	93.9	91.4	89.8
1250	88.1	89.4	89.9	89.7	88.7	88.7	90.1	91.7	94.1	95.6	98.1	99.2	99.1	94.1	91.6	89.5
1600	88.5	90.5	90.8	90.3	89.5	89.5	90.0	91.8	94.2	95.8	98.2	99.1	99.3	94.5	91.8	89.4
2000	90.1	92.1	92.6	92.1	90.8	90.8	90.8	92.8	95.4	96.6	99.3	99.9	100.4	95.4	92.3	89.8
2500	96.9	99.8	101.4	101.4	98.9	98.1	95.1	94.8	96.3	98.8	100.8	101.9	102.6	98.1	94.1	91.7
3150	94.1	97.2	98.7	98.7	96.6	96.1	93.3	93.9	95.4	98.4	100.4	102.2	102.4	98.9	94.9	92.0
4000	91.0	93.3	93.5	93.3	91.8	91.0	90.5	93.0	95.0	96.7	99.7	99.8	101.3	96.6	93.2	89.7
5000	92.5	94.5	96.7	96.3	92.7	93.0	90.8	91.8	94.0	95.8	98.7	98.6	100.2	95.2	92.7	88.1
6300	91.8	93.6	94.1	93.6	91.3	93.1	89.0	90.6	92.3	96.1	97.0	98.8	98.6	94.8	91.1	88.9
8000	90.8	93.4	93.8	94.1	91.4	91.3	87.9	90.4	92.9	94.4	96.6	96.8	98.6	94.3	91.3	86.9
10000	88.0	90.0	91.0	91.0	88.3	88.6	85.6	88.7	90.3	92.0	94.5	95.0	96.1	91.1	89.5	84.9

TABLE X. - NOISE OF QF-1A CONFIGURATION 77 (INACTIVE SHORT STATOR,
HARD INLET WITH NO RINGS, INACTIVE EXHAUST DUCT)

[Data adjusted to standard day of 25⁰ C and 70 percent relative humidity;
SPL re 2×10⁻⁵ N/m².]

(a) 60 Percent of design speed.

FREQUENCY	ANGLE, DEG															
	10	20	30	40	50	60	70	80	90	100	110	120	130	140	150	160
	1/3-OCTAVE BAND SOUND PRESSURE LEVELS (SPL) ON 45.7 METER RADIUS															
50	72.9	70.6	70.6	70.6	69.2	67.6	69.9	70.2	71.2	72.1	70.9	70.7	71.1	71.9	73.6	76.5
63	70.9	68.8	69.1	68.4	69.6	69.1	68.1	68.8	69.1	68.4	70.1	70.3	78.3	73.3	74.4	77.0
80	73.3	73.3	70.8	70.1	70.3	68.9	67.1	68.8	69.3	69.3	71.3	71.9	73.8	74.6	76.3	78.3
100	78.8	78.3	77.3	76.3	74.8	75.1	72.5	73.3	74.1	73.8	74.3	75.4	76.0	77.0	78.3	79.3
125	81.6	83.4	82.1	81.1	79.4	77.9	77.4	76.3	77.4	77.6	77.8	78.4	78.9	78.9	79.4	80.0
160	83.6	84.5	81.6	81.0	79.5	77.6	78.5	77.5	78.5	78.3	79.8	80.4	78.8	79.3	78.5	79.4
200	83.2	83.9	81.2	78.9	76.6	76.7	75.9	76.2	76.9	76.7	79.1	79.0	79.6	79.2	78.7	78.5
250	84.8	85.8	83.3	81.5	80.2	79.2	78.7	80.0	81.2	82.5	83.5	83.7	83.2	81.7	79.7	78.7
315	85.5	84.7	82.2	81.7	80.5	80.0	79.7	79.9	81.4	82.7	84.2	83.9	82.7	81.2	80.0	79.6
400	83.6	82.9	84.2	81.9	79.6	79.7	80.1	81.1	82.9	84.7	85.9	85.8	84.6	82.4	79.4	79.1
500	84.4	84.4	82.4	80.7	79.4	78.5	78.5	79.9	82.0	83.7	85.0	85.0	83.5	82.4	79.5	79.1
630	83.1	83.4	81.9	80.4	78.1	76.6	76.4	77.8	79.6	81.3	82.6	82.9	82.3	81.9	78.1	77.8
800	81.9	81.9	81.2	80.0	77.2	76.7	76.0	77.2	79.4	81.2	83.0	83.0	82.9	82.5	77.5	76.7
1000	81.0	81.2	80.9	79.2	77.0	75.7	75.5	76.5	78.4	79.9	82.0	82.3	82.2	81.5	76.9	76.3
1250	82.2	82.5	82.2	80.5	78.0	76.5	75.8	76.5	78.8	80.3	83.0	82.9	82.7	81.7	77.7	76.6
1600	87.1	88.3	87.4	85.9	84.4	81.6	79.6	79.1	81.1	82.9	85.6	85.4	88.1	85.1	81.1	78.8
2000	93.5	95.7	94.2	92.9	92.4	89.0	86.4	84.9	85.5	88.0	89.5	90.3	94.9	92.0	88.2	85.4
2500	83.2	84.2	84.2	84.1	81.4	79.2	76.4	77.4	79.6	81.7	84.2	84.3	85.2	83.2	79.2	76.8
3150	84.0	85.2	85.2	85.5	84.2	81.5	77.2	78.2	80.2	83.2	85.2	85.8	86.7	85.3	79.8	77.6
4000	87.8	89.7	89.1	90.4	88.3	86.0	81.0	80.3	82.0	83.5	87.2	86.9	90.0	88.2	82.7	79.7
5000	83.5	84.5	86.2	86.0	82.7	80.2	76.2	76.8	79.3	81.0	84.3	83.8	86.0	83.5	79.8	75.8
6300	82.8	84.5	84.5	84.8	83.3	81.2	75.0	75.6	77.3	81.2	82.3	84.4	84.5	83.0	78.3	76.6
8000	83.2	84.0	83.0	84.2	82.7	79.8	73.7	75.0	77.5	79.2	81.7	82.0	84.3	82.8	78.2	73.9
10000	79.5	81.0	81.0	82.0	79.5	77.3	71.3	72.5	74.5	77.0	79.3	79.8	81.8	79.8	76.2	72.2

TABLE X. - Continued.

(b) 70 Percent of design speed.

FREQUENCY	ANGLE, DEG															
	10	20	30	40	50	60	70	80	90	100	110	120	130	140	150	160
	1/3-OCTAVE BAND SOUND PRESSURE LEVELS (SPL) ON 45.7 METER RADIUS															
50	75.1	73.1	72.8	72.6	72.0	71.8	73.1	74.0	74.3	75.5	74.5	74.9	75.1	75.6	78.3	79.8
63	72.2	72.4	71.9	71.7	71.5	70.5	71.4	71.2	71.2	72.4	73.5	74.3	79.5	77.2	78.5	81.4
80	77.2	77.8	75.5	73.3	71.3	70.8	70.8	72.0	72.2	73.3	75.7	77.1	77.8	79.3	80.7	82.7
100	82.8	82.8	82.0	80.8	78.3	78.7	78.2	76.7	78.3	78.3	79.5	80.3	82.2	82.2	83.0	83.7
125	87.0	87.7	87.2	86.2	84.2	83.9	83.2	81.0	83.4	82.7	84.4	84.9	84.7	85.2	85.0	84.7
160	68.0	88.7	87.4	85.4	84.7	83.5	83.9	83.0	85.7	84.0	86.5	86.0	85.4	86.5	84.4	85.6
200	87.5	87.3	85.7	82.3	82.7	81.5	81.8	82.2	83.0	83.2	84.5	85.1	86.8	85.7	84.5	85.5
250	87.1	87.7	86.1	85.3	85.1	83.9	85.4	86.9	88.4	89.6	90.8	91.3	90.6	88.2	85.2	84.5
315	85.7	85.7	84.9	85.6	85.7	85.6	85.4	86.9	88.6	90.1	91.6	90.5	89.2	87.1	85.4	85.1
400	84.9	84.4	86.3	84.6	84.3	85.3	85.9	88.1	89.6	90.9	92.8	91.9	90.9	88.4	85.3	84.5
500	85.8	85.5	85.0	84.6	84.1	84.5	84.8	86.6	89.0	90.5	92.0	91.2	90.3	88.6	85.6	84.5
630	84.1	84.2	83.6	83.4	82.2	81.7	82.9	84.6	86.4	87.7	89.1	88.8	89.1	87.4	83.7	82.6
800	83.4	83.2	83.2	83.1	81.6	80.9	81.9	83.7	85.7	87.2	88.9	89.0	89.1	87.6	82.6	81.3
1000	82.9	82.9	82.9	83.3	82.4	81.3	81.4	82.9	85.3	86.3	87.9	89.0	88.6	86.4	81.6	81.2
1250	63.2	83.9	84.1	83.4	82.1	80.9	81.2	82.9	85.2	86.7	88.6	89.5	88.7	86.4	82.7	81.1
1600	85.0	85.5	86.0	85.4	83.2	81.6	81.7	83.3	86.0	87.5	89.7	89.9	90.0	87.0	82.7	80.6
2000	93.7	95.0	96.3	97.5	95.8	94.2	89.2	89.2	90.5	91.3	94.2	95.3	98.0	94.0	89.0	86.4
2500	89.5	90.5	91.7	92.2	91.0	89.3	85.0	86.0	87.8	89.5	91.3	92.6	94.7	91.7	87.0	84.4
3150	84.9	86.3	86.8	87.8	86.9	84.6	82.3	83.9	86.1	88.9	90.3	91.2	91.4	89.1	83.6	81.7
4000	88.8	90.6	91.6	93.8	91.6	89.6	86.1	86.2	87.4	88.7	91.6	91.7	93.6	90.7	85.8	82.5
5000	86.0	87.2	89.5	90.5	87.0	85.6	82.9	83.2	85.5	86.9	89.7	89.3	92.2	88.9	84.9	80.6
6300	85.3	88.0	88.3	89.8	89.2	88.2	82.5	82.2	83.7	87.5	88.0	90.3	90.0	87.5	83.0	80.9
8000	85.1	86.9	86.7	86.2	86.2	84.9	80.2	81.5	83.9	85.7	87.6	88.2	89.5	87.4	82.9	78.7
10000	82.6	84.5	85.3	86.8	84.0	83.0	78.0	79.3	81.0	83.1	85.3	86.1	87.1	84.4	81.0	77.0

TABLE X. - Continued.

(c) 80 Percent of design speed.

FREQUENCY	ANGLE, DEG															
	10	20	30	40	50	60	70	80	90	100	110	120	130	140	150	160
1/3-OCTAVE BAND SOUND PRESSURE LEVELS (SPL) ON 45.7 METER RADIUS																
50	83.8	76.7	81.8	81.7	83.5	82.8	82.2	81.7	78.7	81.7	79.8	79.9	79.5	81.2	81.5	83.5
63	74.3	75.2	73.5	74.0	74.2	73.5	74.0	74.7	75.3	75.5	77.2	77.6	81.3	80.8	82.3	84.9
80	77.6	79.0	75.3	74.1	73.6	73.8	74.5	75.0	75.8	77.3	79.6	80.4	82.0	83.5	84.8	86.4
100	83.3	82.3	82.2	80.7	79.8	81.0	79.8	80.2	81.8	82.7	83.8	84.1	85.3	86.5	88.2	88.4
125	85.1	84.9	84.6	84.1	84.2	84.6	84.7	85.2	86.7	87.6	88.7	89.0	88.7	89.2	88.9	87.8
160	84.7	85.0	86.0	85.3	86.2	87.5	87.8	88.7	90.2	90.7	91.3	91.6	90.7	90.2	89.0	88.5
200	86.1	87.6	86.1	85.1	85.9	86.9	85.6	87.1	87.2	87.4	89.1	89.5	90.1	89.2	88.4	89.1
250	84.6	86.3	86.1	86.6	88.1	87.6	88.4	89.6	91.3	93.4	94.6	94.5	94.1	91.8	89.8	87.8
315	85.0	85.6	86.8	88.0	88.8	89.0	89.6	91.3	93.1	95.0	95.2	95.2	93.5	91.0	89.3	88.7
400	84.4	85.3	87.1	87.1	86.9	89.4	90.4	91.8	93.4	94.9	95.9	96.0	95.1	91.4	89.4	88.7
500	85.3	86.0	85.7	86.3	87.2	88.2	89.2	91.3	93.2	94.2	95.5	95.4	94.8	91.8	89.5	88.2
630	84.7	85.4	85.7	86.4	86.2	86.9	88.1	90.1	92.2	93.7	95.1	95.5	94.9	91.7	89.1	87.1
800	84.6	85.5	86.0	86.5	85.8	86.0	87.6	89.1	90.6	92.5	94.6	95.2	96.1	92.6	87.8	86.3
1000	84.4	85.7	86.4	86.2	85.2	85.5	87.0	88.5	90.5	91.9	94.2	95.5	95.4	91.5	87.0	86.3
1250	85.1	86.8	86.9	86.9	86.1	85.4	86.8	88.3	90.8	92.4	94.9	95.2	95.3	91.6	88.1	86.3
1600	86.3	87.3	87.6	87.8	87.3	86.1	86.8	88.1	90.8	92.8	95.3	95.4	96.0	92.3	88.1	85.5
2000	88.2	89.4	90.5	91.2	91.0	88.5	88.2	89.2	91.8	93.8	96.3	96.4	97.0	93.4	89.3	86.4
2500	94.5	97.9	99.9	102.0	103.2	100.0	97.7	94.2	94.0	96.0	98.4	100.0	101.2	97.9	93.5	90.8
3150	87.6	89.6	90.1	90.9	90.7	88.1	87.1	88.8	90.9	93.9	95.8	97.2	97.3	94.1	89.4	87.0
4000	88.5	90.4	90.7	91.4	89.9	88.0	86.9	88.9	91.5	93.0	96.1	96.2	97.6	93.8	89.2	85.9
5000	91.1	92.6	95.8	97.3	94.9	93.1	90.8	89.3	90.6	92.1	94.9	95.1	96.9	93.1	89.8	85.2
6300	87.6	89.9	89.9	90.4	89.4	88.2	84.9	86.4	87.7	91.9	92.7	94.8	94.7	91.2	86.7	84.8
8000	89.6	90.8	90.8	92.6	91.3	89.6	85.4	86.6	88.9	90.6	92.2	92.5	94.7	91.7	87.4	82.9
10000	86.5	88.3	89.0	89.8	87.3	86.6	82.8	84.3	85.8	88.0	90.1	90.6	92.0	88.6	85.6	81.3

TABLE X. - Concluded.

(d) 90 Percent of design speed.

FREQUENCY	ANGLE, DEG															
	10	20	30	40	50	60	70	80	90	100	110	120	130	140	150	160
1/3-OCTAVE BAND SOUND PRESSURE LEVELS (SPL) ON 45.7 METER RADIUS																
50	83.5	76.3	76.3	82.0	78.0	81.5	81.0	76.8	81.3	82.5	83.3	85.0	83.3	83.3	85.3	88.4
63	77.5	77.8	76.3	77.3	76.8	77.3	77.0	76.8	77.3	78.3	80.3	81.0	83.5	83.0	85.8	88.9
80	79.3	80.8	77.8	75.8	75.8	76.8	77.0	77.8	78.0	79.8	82.0	83.3	85.5	86.8	88.3	91.7
100	87.0	88.8	85.5	84.3	85.8	86.0	83.0	84.5	85.3	85.0	88.5	90.0	90.0	90.5	92.0	93.7
125	87.8	88.3	87.3	86.8	85.6	85.8	85.1	86.6	87.8	88.6	89.3	90.6	92.3	91.6	93.1	92.2
160	85.8	87.5	88.3	86.5	86.5	88.5	88.8	89.5	91.3	92.0	92.5	92.5	92.5	91.8	90.5	90.9
200	87.6	88.3	88.3	85.8	87.1	87.3	86.6	87.8	88.6	89.3	90.3	90.8	92.3	90.6	90.1	90.5
250	86.2	87.7	87.2	88.0	88.2	89.7	91.0	92.2	94.5	95.2	96.5	97.2	96.7	94.2	92.0	91.8
315	87.0	88.3	89.5	90.0	90.3	91.0	92.3	93.8	95.8	96.5	97.0	96.8	95.0	92.3	91.3	92.1
400	87.5	88.2	89.2	90.0	90.2	92.0	92.2	94.0	95.0	96.0	97.7	98.0	96.7	93.2	91.7	92.1
500	88.5	89.8	89.0	90.0	90.5	92.0	91.5	93.5	94.8	95.3	96.8	97.5	97.0	93.0	92.0	92.4
630	87.7	88.7	89.9	89.2	88.7	90.9	91.9	93.9	95.9	96.7	97.2	98.0	97.7	93.9	92.2	91.6
800	88.5	90.0	90.2	90.5	90.0	90.0	91.7	93.5	94.5	95.2	97.7	99.0	100.0	95.2	92.0	91.6
1000	87.8	89.8	90.8	91.1	90.6	90.3	91.3	93.1	94.8	95.6	98.1	99.6	99.6	94.1	91.1	91.7
1250	88.7	89.9	90.7	91.2	89.7	90.2	91.4	92.7	95.2	96.2	98.9	99.7	100.2	95.2	91.9	91.6
1600	89.1	90.9	91.9	91.9	90.6	89.9	91.4	92.9	95.4	96.1	98.9	99.4	100.6	95.1	92.4	90.8
2000	90.3	91.8	93.3	93.3	91.5	90.5	91.0	93.0	95.5	96.7	99.5	99.8	101.2	95.5	92.3	91.6
2500	95.2	98.4	101.4	102.9	100.4	99.2	96.9	94.9	96.7	98.2	100.2	100.9	101.9	96.4	93.2	92.3
3150	94.9	97.9	100.9	102.9	100.4	99.1	97.1	95.1	96.6	98.1	100.1	102.2	102.1	97.9	94.1	93.0
4000	91.1	92.9	93.4	94.4	91.9	90.9	90.6	93.1	95.6	96.4	99.6	100.2	101.1	96.9	92.9	91.0
5000	92.0	94.0	96.5	97.5	93.8	93.0	91.2	92.5	94.7	95.7	98.2	98.0	100.0	95.2	92.0	89.2
6300	90.9	93.6	94.9	96.6	94.1	93.4	89.4	90.9	92.6	95.6	96.4	98.7	98.1	93.9	90.6	90.1
8000	91.3	93.5	94.0	95.7	92.7	91.5	88.5	90.5	92.8	94.3	96.0	96.6	98.3	94.3	90.5	88.2
10000	88.1	90.1	90.6	92.1	88.8	88.4	86.1	88.4	89.9	91.6	93.1	95.0	95.6	91.6	88.1	85.6

TABLE XI. - NOISE OF QF-1A CONFIGURATION 78 (ACTIVE SHORT STATOR,
HARD INLET WITH NO RINGS, INACTIVE EXHAUST DUCT)

[Data adjusted to standard day of 25⁰ C and 70 percent relative humidity;
SPL re 2×10⁻⁵ N/m².]

(a) 60 Percent of design speed.

FREQUENCY	ANGLE, DEG															
	10	20	30	40	50	60	70	80	90	100	110	120	130	140	150	160
	1/3-OCTAVE BAND SOUND PRESSURE LEVELS (SPL) ON 45.7 METER RADIUS															
50	71.4	69.8	69.8	70.1	68.8	67.9	68.9	69.6	70.9	70.8	70.9	70.7	71.9	72.3	74.8	75.0
63	70.6	69.3	68.8	68.9	69.6	68.4	68.3	68.1	69.6	69.3	69.9	70.5	73.1	73.6	74.8	76.3
80	72.7	72.7	70.7	69.2	69.4	68.7	66.5	68.0	69.4	69.7	71.0	71.5	74.0	74.7	77.4	77.3
100	78.1	77.4	76.4	76.1	73.9	74.4	72.9	71.9	74.4	74.1	73.8	75.7	77.1	77.6	78.6	78.5
125	81.4	82.4	80.8	80.6	78.9	77.6	77.3	75.1	76.6	77.1	77.6	78.0	79.3	79.1	80.4	79.2
160	81.2	81.7	79.7	79.2	78.1	76.9	77.1	76.4	77.9	77.9	78.4	79.3	78.7	78.7	78.4	77.8
200	82.2	82.2	80.1	77.6	76.2	75.1	74.7	75.4	75.6	75.2	77.2	77.2	78.7	77.9	77.6	77.3
250	83.1	83.6	81.8	80.1	79.6	78.5	78.1	78.6	80.0	81.5	82.3	83.1	83.0	81.0	79.1	77.2
315	83.0	82.3	81.0	80.3	80.0	79.0	78.8	79.0	80.3	81.7	83.2	83.1	82.5	80.5	79.5	78.2
400	81.2	80.5	82.5	80.5	78.9	79.5	79.0	79.5	81.4	83.4	84.9	85.1	84.4	82.2	79.2	77.4
500	80.8	81.3	80.2	79.2	78.0	77.8	77.8	79.5	81.3	83.8	85.2	85.4	84.0	81.5	79.0	77.5
630	79.1	80.5	78.8	78.0	76.3	76.0	76.1	77.1	79.5	81.5	83.0	82.9	82.6	81.6	78.3	76.5
800	78.1	78.6	78.6	77.8	76.3	75.8	75.6	76.4	78.4	80.8	82.1	81.9	82.6	81.9	77.1	75.3
1000	78.7	79.9	79.4	78.2	76.2	75.1	75.1	75.4	77.7	79.7	81.2	81.7	82.2	81.6	76.2	74.5
1250	80.0	81.5	80.8	79.8	77.3	75.5	75.1	75.6	77.5	79.6	81.6	82.4	82.1	81.1	77.0	74.9
1600	85.5	88.0	87.2	86.0	83.0	80.2	78.3	77.2	78.8	81.7	83.3	84.1	85.8	83.5	79.5	76.9
2000	91.7	94.5	93.8	93.8	90.0	87.5	85.0	81.5	82.7	87.2	87.7	88.6	91.7	90.2	85.7	82.9
2500	82.1	83.9	83.7	83.6	80.9	78.1	75.6	75.6	76.9	79.2	81.2	82.2	82.6	80.6	76.7	73.8
3150	83.8	85.3	84.8	85.7	83.7	80.8	76.8	76.0	77.0	80.0	81.8	82.8	83.7	81.3	76.8	74.2
4000	87.8	89.2	89.1	90.1	88.2	86.0	80.3	78.3	78.7	80.5	83.3	83.5	86.2	84.7	79.9	76.6
5000	82.9	84.8	85.9	86.1	82.3	80.4	76.3	75.4	76.6	77.9	81.4	81.6	82.6	81.1	78.1	73.0
6300	84.0	85.2	84.3	85.3	83.5	81.7	75.2	74.5	75.3	78.5	80.3	83.0	83.5	81.7	77.5	74.3
8000	82.7	84.9	83.2	85.2	82.6	80.7	73.9	74.1	76.3	78.1	79.7	80.7	82.9	81.7	77.3	72.0
10000	80.3	81.6	81.2	82.8	80.2	78.3	71.8	71.5	73.0	74.7	77.7	78.7	80.3	78.7	75.7	70.3

TABLE XI. - Continued.

(b) 70 Percent of design speed.

FREQUENCY	ANGLE, DEG															
	10	20	30	40	50	60	70	80	90	100	110	120	130	140	150	160
1/3-OCTAVE BAND SOUND PRESSURE LEVELS (SPL) ON 45.7 METER RADIUS																
50	73.5	72.5	72.6	71.6	71.8	71.6	72.6	72.6	73.3	74.1	74.0	74.0	76.1	76.6	78.6	79.8
63	71.4	72.5	71.7	70.5	70.7	70.5	71.2	71.0	71.5	72.7	73.2	74.1	76.7	76.7	78.9	80.4
80	76.1	76.6	73.8	71.5	71.6	70.8	71.3	71.5	71.6	73.8	75.3	77.2	78.6	79.3	80.6	81.8
100	80.7	79.8	79.5	78.7	76.2	75.3	75.7	75.8	77.0	77.7	78.8	79.9	81.7	81.7	84.0	83.7
125	83.5	83.7	83.2	82.5	81.3	79.8	80.8	80.0	80.5	81.7	83.2	83.1	84.8	83.3	84.8	83.2
160	82.3	82.7	82.5	81.2	80.2	80.7	80.5	81.0	82.0	82.7	83.7	83.9	83.8	83.7	83.0	83.1
200	83.7	84.0	82.0	80.2	79.5	78.9	78.9	79.7	79.9	80.9	82.2	82.8	84.0	83.2	83.0	81.9
250	81.8	83.5	82.0	81.6	82.8	81.5	83.1	84.0	86.0	87.8	88.6	89.2	89.1	86.6	84.1	82.7
315	81.6	81.8	81.8	82.8	83.5	83.5	83.3	85.0	86.1	87.8	88.5	88.5	87.6	85.0	84.5	83.3
400	81.4	82.4	83.1	81.9	81.9	83.6	84.1	85.9	86.9	89.2	90.4	90.5	89.7	86.9	83.7	82.6
500	82.7	82.7	82.1	81.7	83.2	83.4	83.6	85.6	87.2	89.7	90.7	90.8	89.6	86.7	84.7	83.1
630	81.2	81.7	81.9	80.9	80.2	81.4	82.2	83.7	86.2	88.9	89.9	89.3	88.7	86.9	83.9	82.1
800	80.2	81.6	81.6	81.4	80.2	80.1	81.4	83.1	85.2	87.9	88.9	88.3	88.6	86.9	82.7	80.8
1000	80.6	81.6	82.3	81.5	80.5	80.0	80.8	82.1	84.1	86.3	87.3	88.4	88.1	86.0	81.3	80.7
1250	81.7	83.0	83.0	82.4	81.0	79.9	80.7	82.0	83.9	86.4	88.0	88.6	88.0	85.4	82.2	80.3
1600	83.7	85.2	85.5	84.5	82.7	80.9	80.8	82.2	84.3	86.5	88.3	88.9	88.8	85.3	82.0	80.1
2000	91.7	94.7	95.7	94.5	94.0	94.0	89.5	88.5	87.6	88.9	91.6	92.5	95.8	90.2	87.0	84.2
2500	87.7	90.0	91.0	90.5	89.0	88.8	84.8	84.2	85.2	86.9	89.0	90.1	92.2	88.0	85.2	82.4
3150	84.8	86.4	86.1	86.6	85.8	83.6	80.4	82.1	83.4	86.8	88.1	88.9	89.3	85.4	81.4	79.5
4000	88.2	90.5	91.3	92.5	91.3	88.7	85.3	84.0	84.8	87.1	89.2	89.2	91.1	87.7	83.2	80.0
5000	85.7	87.6	89.1	89.9	87.4	84.9	82.2	82.1	83.6	84.9	88.1	87.5	89.1	85.9	82.7	78.7
6300	87.1	88.2	88.2	89.2	88.2	87.1	80.9	80.7	81.7	85.1	86.0	88.4	88.9	85.2	80.9	78.8
8000	85.8	87.0	86.6	88.6	86.3	84.5	79.3	80.1	82.3	84.3	85.8	86.3	88.0	85.5	81.3	77.3
10000	83.8	85.1	85.6	86.9	84.4	83.3	77.6	78.4	79.6	81.4	83.9	84.3	85.4	82.6	79.8	75.4

TABLE XI. - Continued.

(c) 80 Percent of design speed.

FREQUENCY	ANGLE, DEG															
	10	20	30	40	50	60	70	80	90	100	110	120	130	140	150	160
1/3-OCTAVE BAND SOUND PRESSURE LEVELS (SPL) ON 45.7 METER RADIUS																
50	82.4	75.1	79.9	79.2	83.1	77.6	81.6	77.6	76.7	78.1	77.1	79.1	79.9	79.9	81.9	83.1
63	72.9	74.6	73.7	72.9	74.1	73.9	73.9	73.7	74.6	75.7	76.7	77.5	78.9	80.9	83.2	83.5
80	75.9	77.1	75.2	73.4	73.6	73.2	74.4	74.2	75.2	77.1	78.2	79.7	81.9	83.2	85.1	85.8
100	82.3	80.8	80.8	79.3	78.1	78.8	79.8	79.3	80.4	82.6	82.6	83.4	85.4	86.4	87.8	87.1
125	82.6	81.8	81.8	81.3	80.9	81.4	82.4	83.4	84.6	85.8	87.3	86.9	87.9	88.1	88.9	87.6
160	81.6	82.6	83.2	83.1	82.7	84.2	84.9	85.7	86.6	86.9	87.6	86.5	87.9	87.9	87.7	87.6
200	82.9	84.2	83.1	82.2	82.6	83.2	82.7	84.1	83.7	84.6	85.7	86.3	87.4	86.9	86.9	86.8
250	81.9	83.1	83.3	84.4	84.6	85.3	85.9	86.6	88.6	90.1	91.6	91.7	91.8	89.9	88.4	86.1
315	82.6	83.6	85.1	85.8	86.3	86.8	87.4	88.6	90.3	91.6	92.3	91.9	90.8	89.1	87.8	86.8
400	83.0	83.9	85.4	85.2	85.0	87.7	88.4	89.4	91.2	92.5	93.7	93.8	93.0	90.5	88.5	86.9
500	83.5	84.6	84.5	85.1	86.1	86.8	88.1	89.6	91.1	92.5	93.3	93.7	93.1	90.1	88.6	86.7
630	84.0	85.0	85.5	86.0	85.3	86.5	87.5	89.0	91.3	92.8	93.6	93.7	94.0	91.1	88.5	86.7
800	83.3	85.1	85.4	85.6	85.3	85.6	86.8	88.1	89.6	91.6	93.6	94.5	95.1	91.4	87.4	86.0
1000	83.8	85.7	85.8	86.0	85.0	85.2	86.3	87.8	89.7	91.3	93.2	94.6	94.8	90.8	86.8	85.6
1250	84.4	86.0	86.0	86.4	85.2	84.7	85.5	87.0	89.4	91.7	93.9	94.6	94.7	90.9	87.7	85.6
1600	85.7	87.2	87.5	87.8	86.7	85.7	86.0	86.8	89.7	91.8	94.0	94.1	95.2	91.2	87.7	84.9
2000	87.8	89.3	90.9	90.8	89.9	88.6	87.1	87.3	89.6	92.4	94.3	94.5	95.6	91.4	88.3	85.0
2500	93.2	96.9	99.2	99.9	101.4	99.4	94.9	93.0	92.0	93.5	95.7	97.5	98.2	94.0	91.0	87.9
3150	87.4	89.3	89.3	90.3	89.6	87.7	85.8	87.1	88.9	91.9	93.3	95.2	95.3	91.1	87.3	84.7
4000	88.5	90.2	90.7	91.7	89.3	87.8	86.0	87.0	89.3	90.9	93.9	93.7	95.4	91.6	87.0	84.2
5000	89.8	92.7	95.2	96.8	94.0	92.3	89.6	88.1	88.8	89.8	92.8	92.8	94.1	90.6	88.0	83.2
6300	89.2	90.2	90.0	91.0	89.5	88.3	83.6	84.8	86.3	89.5	90.5	93.0	93.2	89.3	85.5	83.3
8000	89.7	91.1	90.7	92.4	90.7	89.5	84.5	85.0	86.9	88.9	90.4	90.8	92.9	90.0	86.0	81.2
10000	87.1	89.1	89.3	90.3	87.6	86.7	82.1	82.9	84.4	86.1	88.3	88.9	90.1	86.9	84.3	79.8

TABLE XI. - Concluded.

(d) 90 Percent of design speed.

FREQUENCY	ANGLE, DEG															
	10	20	30	40	50	60	70	80	90	100	110	120	130	140	150	160
	1/3-OCTAVE BAND SOUND PRESSURE LEVELS (SPL) ON 45.7 METER RADIUS															
50	78.4	75.2	78.1	79.6	81.1	78.9	78.9	78.4	79.4	79.2	81.1	81.0	83.2	83.4	85.4	87.4
63	75.8	77.1	76.9	76.3	76.4	76.3	75.9	76.9	77.3	78.8	80.8	80.7	82.6	83.9	85.8	87.8
80	78.4	79.4	77.5	75.2	75.4	75.7	75.7	76.9	78.5	79.9	81.9	83.0	85.7	86.7	88.9	90.3
100	84.3	84.8	82.3	81.6	81.1	83.4	82.9	83.9	86.9	87.6	89.4	89.7	90.1	91.2	92.1	91.3
125	84.7	85.1	84.9	83.7	83.4	83.7	83.9	84.4	86.4	87.7	89.7	89.8	91.2	91.9	92.7	90.8
160	84.6	85.9	86.3	85.3	85.3	87.1	87.3	88.4	89.8	90.8	91.1	91.5	91.8	91.1	90.8	90.6
200	85.6	88.1	85.9	84.1	84.8	85.3	85.3	86.6	86.4	87.6	88.1	88.7	89.8	89.4	89.8	90.3
250	85.0	86.5	86.1	86.3	86.5	87.5	87.5	88.3	90.0	92.1	93.1	93.4	93.8	93.0	91.5	89.8
315	86.4	87.0	87.9	88.5	88.2	89.7	90.2	91.4	92.7	94.2	94.4	94.1	93.0	91.9	90.9	90.4
400	86.7	86.8	88.2	87.7	88.3	89.8	89.8	91.2	92.7	94.5	95.2	95.4	95.2	92.8	91.5	90.2
500	87.3	88.2	89.0	88.8	90.2	90.5	91.5	92.3	93.2	94.8	95.5	95.4	95.7	92.8	91.5	90.0
630	87.5	88.5	88.6	88.8	89.1	90.0	91.0	92.3	94.1	95.6	96.0	96.2	96.5	94.0	91.6	89.9
800	87.5	89.1	89.0	89.8	88.6	89.0	90.3	91.6	92.3	94.3	96.3	97.6	98.6	95.0	91.3	89.9
1000	87.5	89.2	89.5	90.9	90.0	89.7	90.5	92.0	93.9	96.4	98.2	98.1	98.4	94.5	91.2	90.1
1250	88.0	89.8	90.0	90.3	89.8	89.6	90.5	91.3	94.0	97.3	98.5	99.0	99.3	95.0	92.0	89.8
1600	88.5	90.0	91.0	91.2	90.0	89.7	89.7	91.2	93.4	95.9	97.7	97.8	99.5	95.0	91.7	88.9
2000	89.9	91.4	92.9	92.8	91.3	90.6	89.9	91.2	93.7	95.5	98.2	98.3	99.8	94.7	91.8	88.9
2500	94.6	96.1	99.7	101.7	101.1	98.2	95.2	93.1	94.4	96.1	98.2	99.5	99.6	95.1	92.2	89.5
3150	94.1	95.6	98.8	100.6	100.1	97.3	95.6	92.8	94.3	96.1	98.1	100.1	99.8	96.1	92.3	89.7
4000	91.1	92.5	92.8	93.6	91.3	90.3	89.6	91.5	93.5	95.3	97.8	98.4	99.6	95.1	91.3	88.2
5000	92.1	93.9	96.1	96.9	92.4	92.1	90.4	90.5	92.4	93.5	97.0	96.7	97.4	93.7	90.9	86.5
6300	92.2	93.0	94.0	95.2	92.4	92.2	88.7	89.2	90.5	93.2	94.5	97.1	97.0	92.9	89.4	87.0
8000	91.3	92.9	93.3	95.3	91.4	90.9	87.2	88.8	91.1	92.6	94.4	94.9	96.8	93.3	90.1	85.4
10000	89.1	90.5	90.8	92.0	88.5	88.0	84.8	87.0	88.3	90.1	92.1	93.0	93.6	90.5	88.0	83.5

TABLE XII. - NOISE OF QF-1A CONFIGURATION 80 (ACTIVE SHORT STATOR,
INACTIVE INLET WITH RINGS, INACTIVE EXHAUST DUCT)

[Data adjusted to standard day of 25⁰ C and 70 percent relative humidity;
SPL re 2×10⁻⁵ N/m².]

(a) 60 Percent of design speed.

FREQUENCY	ANGLE, DEG															
	10	20	30	40	50	60	70	80	90	100	110	120	130	140	150	160
	1/3-OCTAVE BAND SOUND PRESSURE LEVELS (SPL) ON 45.7 METER RADIUS															
50	72.8	71.4	70.9	69.4	70.3	69.3	70.3	69.8	71.6	71.1	72.3	71.9	72.1	72.8	74.9	75.3
63	69.5	69.3	69.1	67.6	69.1	69.1	67.8	68.3	68.6	68.3	70.1	70.9	72.1	73.3	74.6	74.7
80	72.9	72.1	70.6	68.4	69.4	69.6	67.1	68.9	69.1	68.8	70.3	72.4	73.3	74.9	76.3	76.3
100	77.8	77.1	75.6	75.1	73.3	74.0	71.1	71.6	72.5	72.3	73.0	74.7	75.8	76.6	77.8	77.2
125	79.9	80.6	79.8	78.3	76.1	75.9	75.1	74.3	75.1	75.8	77.3	77.2	78.4	78.1	78.9	78.3
160	81.0	81.0	79.2	77.8	77.2	76.0	76.7	76.3	77.3	77.2	78.7	79.3	78.7	78.5	78.5	77.6
200	80.7	81.5	78.7	76.3	75.3	74.7	74.2	75.0	76.2	75.8	77.7	77.8	78.3	77.7	77.7	77.2
250	81.6	83.2	81.7	78.7	78.2	77.4	76.7	78.7	80.2	81.7	82.7	83.7	82.9	81.2	78.7	76.3
315	82.7	82.4	80.6	79.1	79.6	78.6	78.1	79.2	81.1	82.4	83.2	84.2	82.6	80.4	80.1	78.5
400	80.8	79.8	80.9	79.1	77.9	77.9	77.8	79.3	81.3	83.8	84.9	85.0	84.1	82.1	79.1	76.8
500	80.5	80.2	79.2	77.4	76.2	76.5	76.7	79.0	80.9	82.9	84.9	85.0	83.5	81.5	78.5	76.6
630	79.2	80.0	77.9	76.4	75.5	75.2	75.4	76.7	78.7	80.9	82.7	82.8	82.2	81.0	77.9	76.1
800	78.5	79.2	78.4	77.5	76.0	75.0	75.0	76.2	78.0	80.2	81.9	81.9	82.4	82.2	76.9	74.6
1000	79.6	79.8	79.0	78.0	76.3	74.8	74.1	75.8	77.5	79.1	81.0	82.2	81.6	81.3	76.5	74.2
1250	80.3	80.8	80.5	79.2	77.0	75.0	74.2	75.5	77.3	78.3	81.3	82.4	82.2	81.2	77.0	74.0
1600	85.5	87.0	85.8	84.3	81.0	79.9	76.7	77.0	79.3	80.7	83.0	83.9	85.3	83.0	78.8	75.2
2000	92.8	95.6	95.1	93.3	89.8	91.1	83.8	83.0	86.8	86.8	87.6	89.6	93.1	91.0	86.6	82.9
2500	83.5	84.6	84.6	83.3	80.6	78.0	75.1	75.1	77.3	79.8	81.1	82.4	83.1	81.1	77.0	73.5
3150	84.6	85.4	84.8	84.3	82.3	79.1	74.9	75.3	77.3	79.1	81.4	82.9	84.3	81.8	76.9	74.2
4000	88.4	89.9	88.8	89.3	86.7	83.2	78.7	77.9	78.5	80.5	83.1	84.3	86.9	84.8	80.1	76.3
5000	83.0	84.4	85.7	84.9	80.9	78.0	74.2	74.4	76.4	78.0	81.4	81.3	83.0	81.9	78.2	73.3
6300	84.9	85.3	85.1	84.6	82.3	80.3	74.4	74.1	75.4	78.8	80.4	83.2	85.4	81.9	77.9	74.7
8000	83.3	84.8	83.6	84.0	81.5	78.8	73.0	73.5	76.0	77.5	79.6	81.1	83.0	82.0	77.1	72.2
10000	81.0	82.0	82.0	82.0	79.3	77.0	70.5	71.1	72.6	75.3	77.3	79.0	81.0	78.8	76.0	70.6

TABLE XII. - Continued.

(b) 70 Percent of design speed.

FREQUENCY	ANGLE, DEG															
	10	20	30	40	50	60	70	80	90	100	110	120	130	140	150	160
1/3-OCTAVE BAND SOUND PRESSURE LEVELS (SPL) ON 45.7 METER RADIUS																
50	75.4	73.9	72.4	72.3	70.6	72.1	73.3	74.1	74.6	73.6	75.1	75.4	76.4	76.8	78.8	79.7
63	72.1	72.8	71.9	71.3	71.3	71.1	72.4	71.9	72.1	72.1	72.9	74.3	76.6	76.3	78.1	79.3
80	75.6	76.8	73.8	72.1	71.5	71.1	71.8	71.8	72.3	72.5	74.1	76.7	78.3	79.0	80.5	81.2
100	81.1	80.3	80.0	79.0	75.5	75.8	74.6	75.0	76.5	76.6	78.1	79.2	81.0	81.5	83.0	83.0
125	83.9	84.4	83.8	81.9	80.3	80.1	79.8	79.9	80.8	81.4	82.1	83.0	83.6	83.8	83.9	83.5
160	83.1	83.6	82.8	81.9	79.9	80.4	80.6	80.9	81.9	81.9	83.6	84.0	83.6	83.8	83.3	82.7
200	83.1	83.4	81.6	79.8	78.9	78.8	79.4	80.4	79.9	80.8	81.4	82.7	83.4	82.4	82.3	81.8
250	81.9	83.6	82.4	80.9	81.2	80.4	81.4	83.4	84.7	86.6	87.4	88.3	88.6	86.2	83.9	81.3
315	81.4	81.5	81.7	83.0	83.0	83.2	83.5	84.7	86.4	88.0	89.0	89.1	87.5	85.2	84.0	82.6
400	81.0	81.5	81.7	82.5	81.4	82.2	83.4	85.4	87.0	88.7	89.9	90.5	89.2	86.7	83.2	81.1
500	81.6	82.1	82.0	81.5	80.5	81.8	82.3	84.5	86.6	88.5	90.0	90.2	88.5	86.6	83.6	82.4
630	81.0	81.7	80.5	81.2	79.2	80.5	81.4	83.2	85.5	87.2	88.5	88.8	87.9	86.5	83.2	81.6
800	80.7	81.9	81.2	81.2	79.5	79.5	80.5	82.7	84.5	86.2	88.2	88.3	88.0	87.0	82.2	80.2
1000	81.8	82.9	81.9	82.1	79.8	79.4	80.3	81.9	83.9	84.9	87.3	88.5	87.9	85.9	80.9	79.7
1250	82.5	83.7	83.0	82.5	79.9	79.7	80.4	81.5	83.9	84.9	87.9	88.8	87.9	85.7	81.9	79.4
1600	84.8	85.7	85.2	84.4	81.8	80.2	80.0	81.5	84.2	85.7	88.2	88.8	88.3	85.7	81.8	79.2
2000	91.7	96.2	94.4	96.4	92.4	89.2	86.0	85.0	87.4	89.5	92.7	93.3	94.0	91.0	86.5	83.3
2500	90.6	95.1	93.2	95.1	91.1	88.2	84.7	83.9	86.4	88.7	91.4	91.8	93.2	90.7	86.6	83.6
3150	86.9	88.1	87.2	87.6	85.1	83.1	80.4	82.1	83.9	85.9	88.1	89.3	89.7	86.2	81.9	79.6
4000	88.9	90.4	90.8	91.6	88.8	86.4	82.9	83.2	84.7	86.9	89.5	90.0	90.9	87.8	83.4	80.0
5000	87.0	89.0	90.5	91.0	87.0	84.7	81.5	81.7	83.7	85.2	88.0	88.0	89.5	87.3	83.3	78.6
6300	88.5	89.2	89.0	89.3	87.8	86.5	80.0	80.7	82.0	85.5	86.6	89.1	90.5	86.0	81.5	79.4
8000	85.9	88.1	87.3	88.4	85.7	83.7	78.6	79.8	82.1	83.9	86.1	86.9	88.2	85.9	82.1	77.5
10000	84.3	86.0	86.3	86.8	83.3	82.3	77.0	78.0	79.5	81.7	83.7	85.0	86.2	82.6	80.2	75.1

TABLE XII. - Continued.

(c) 80 Percent of design speed.

FREQUENCY	ANGLE, DEG															
	10	20	30	40	50	60	70	80	90	100	110	120	130	140	150	160
1/3-OCTAVE BAND SOUND PRESSURE LEVELS (SPL) ON 45.7 METER RADIUS																
50	80.1	74.6	75.8	81.8	78.3	83.8	77.3	81.8	76.6	78.5	80.1	79.4	79.8	80.8	82.8	83.3
63	72.3	75.0	73.3	73.7	74.5	73.8	74.5	74.5	74.7	75.3	76.8	77.4	79.7	80.7	82.0	82.5
80	75.6	77.3	74.1	73.4	73.9	72.9	73.1	74.1	75.3	76.4	77.8	79.0	81.8	83.1	85.1	85.1
100	81.3	80.1	78.6	79.6	79.1	79.3	77.4	79.3	80.1	80.8	82.4	83.7	84.9	85.9	86.9	87.0
125	82.6	82.5	81.1	81.1	80.8	81.1	81.6	83.1	84.1	85.5	86.0	87.1	87.3	88.5	88.8	87.7
160	81.8	82.3	82.7	82.3	82.0	84.3	84.0	85.0	86.7	87.5	88.0	88.7	88.5	88.2	88.0	87.5
200	82.8	84.0	83.2	82.0	82.8	83.3	82.7	84.5	84.5	84.7	85.5	86.4	86.8	86.3	86.3	86.2
250	81.7	83.1	82.4	82.6	83.4	83.7	84.9	85.7	88.1	89.4	90.7	91.2	91.2	89.6	87.9	85.3
315	82.9	83.4	83.9	84.9	85.9	86.2	87.2	88.7	90.5	91.4	92.9	92.8	91.0	89.5	87.7	87.1
400	83.0	83.5	84.7	85.4	85.0	86.7	88.0	89.5	91.2	92.4	93.4	93.5	92.7	90.0	87.4	85.8
500	84.1	84.2	84.2	84.6	85.1	86.2	87.1	89.6	90.9	92.7	94.1	93.7	92.9	90.4	88.2	86.5
630	84.7	84.5	84.7	84.7	84.2	86.0	87.4	88.5	91.0	92.7	93.5	93.8	93.7	91.2	88.2	86.2
800	84.6	84.7	85.4	85.4	84.4	85.1	86.4	88.4	89.7	91.2	93.1	94.2	95.1	91.6	87.4	85.3
1000	84.8	85.8	85.5	85.1	84.0	84.6	86.0	87.5	89.6	91.0	93.3	94.9	94.5	91.1	86.8	85.0
1250	85.2	86.2	86.0	85.5	84.0	84.2	85.8	87.2	89.7	90.8	93.7	95.1	94.3	91.2	87.5	84.7
1600	86.8	87.6	87.8	87.0	85.5	85.0	85.6	86.9	89.6	91.3	93.9	94.5	94.3	91.4	87.4	84.3
2000	88.3	88.8	89.7	89.2	87.3	86.3	86.0	87.2	90.2	92.7	94.5	94.8	95.0	91.3	87.8	84.7
2500	97.7	97.7	100.0	101.0	99.0	95.9	93.7	91.0	92.5	94.9	96.5	98.1	100.7	96.2	91.9	88.8
3150	89.6	90.2	90.6	90.6	89.1	86.9	85.6	87.1	89.9	91.7	93.7	95.5	95.9	92.1	88.1	85.3
4000	90.0	91.1	91.0	91.1	89.3	87.1	85.8	87.6	89.9	91.7	94.0	94.5	95.5	91.7	87.6	84.5
5000	91.8	93.6	96.3	96.9	92.8	90.6	87.9	87.4	88.9	90.4	93.4	93.9	94.8	91.6	88.4	83.5
6300	89.7	90.7	90.7	90.5	89.1	87.9	83.9	85.2	87.1	90.1	91.1	93.7	95.2	89.9	86.1	84.0
8000	90.0	91.8	91.5	92.3	90.7	88.7	84.5	85.3	87.7	89.2	90.8	92.1	93.3	90.7	86.8	82.1
10000	87.5	89.1	89.6	89.8	87.5	86.0	82.3	83.0	84.8	86.8	89.0	89.8	91.3	87.3	84.6	80.3

TABLE XII. - Concluded.

(d) 90 Percent of design speed.

FREQUENCY	ANGLE, DEG															
	10	20	30	40	50	60	70	80	90	100	110	120	130	140	150	160
	1/3-OCTAVE BAND SOUND PRESSURE LEVELS (SPL) ON 45.7 METER RADIUS															
50	83.0	77.3	77.5	81.8	78.5	83.8	80.2	79.0	78.3	80.8	81.2	82.1	82.7	83.0	84.8	87.1
63	76.8	76.7	76.5	77.0	76.7	78.2	77.0	77.0	77.5	78.5	79.7	80.8	82.0	83.2	85.2	86.4
80	78.5	79.2	76.2	75.4	75.0	75.7	75.7	76.2	77.0	78.4	80.5	81.8	84.9	85.7	87.9	88.4
100	88.0	87.0	85.5	85.0	84.0	82.2	80.7	82.0	82.2	83.7	86.3	86.1	88.2	88.8	91.0	91.1
125	85.4	85.7	85.6	83.7	82.9	83.2	83.7	84.4	85.6	87.2	88.4	89.5	90.9	91.1	92.7	91.0
160	84.2	85.0	85.9	84.9	84.7	87.0	87.0	88.4	89.4	90.4	91.0	91.9	91.4	91.9	90.5	90.6
200	85.1	86.7	85.9	84.4	85.2	86.1	85.6	86.7	86.9	87.4	87.7	89.2	89.6	89.2	89.7	89.8
250	84.8	85.7	86.3	86.2	85.5	86.7	87.0	87.8	89.5	91.3	92.5	93.1	93.3	92.7	90.8	89.1
315	85.0	86.6	87.5	87.6	88.1	88.8	89.3	91.1	93.0	93.8	95.0	94.6	93.1	92.0	90.5	90.7
400	86.3	87.0	87.8	88.6	89.1	91.1	90.8	91.5	92.6	93.8	95.6	96.2	95.0	92.5	90.8	89.5
500	87.6	88.1	87.1	87.6	88.1	89.8	90.5	92.3	93.5	94.6	95.1	95.6	95.3	92.8	90.8	89.0
630	87.6	89.0	88.3	88.1	88.0	89.6	90.8	92.3	93.8	96.1	96.1	96.5	96.3	93.8	91.8	89.3
800	87.7	88.4	88.6	88.1	87.7	88.7	90.4	91.2	92.7	94.4	96.2	98.0	98.6	95.1	90.9	89.1
1000	88.3	89.6	89.1	89.1	88.6	89.3	90.3	92.1	93.8	95.3	97.6	98.7	98.6	94.8	90.6	89.1
1250	88.8	89.8	89.8	89.3	88.3	88.9	89.9	91.4	94.3	95.4	98.3	99.4	98.8	95.6	91.8	89.2
1600	89.1	90.9	91.1	90.2	88.7	88.9	89.7	91.1	93.6	95.2	97.9	99.0	98.9	95.2	91.1	88.5
2000	90.3	92.1	92.4	91.3	90.3	89.8	89.8	91.4	93.6	96.3	98.2	98.5	99.2	94.7	91.7	88.4
2500	95.4	97.3	97.8	98.6	97.1	94.8	92.3	92.6	94.8	97.3	98.8	100.2	99.9	95.6	91.6	89.2
3150	98.2	100.5	101.0	102.3	100.7	98.4	94.4	94.2	94.9	96.9	98.7	101.1	101.9	97.7	93.2	90.9
4000	92.3	94.0	93.8	93.6	92.1	90.6	90.0	92.0	94.0	96.3	98.8	99.1	99.6	96.0	91.5	88.4
5000	91.8	94.3	95.8	95.1	92.0	90.8	89.3	90.8	93.1	94.6	97.3	97.4	97.5	94.3	91.3	86.7
6300	93.1	95.1	96.5	96.0	94.4	93.2	89.5	90.2	91.5	95.0	95.7	98.5	99.5	94.1	90.2	88.2
8000	91.9	94.2	93.9	94.4	92.0	91.0	87.4	89.7	91.9	93.9	95.4	96.5	97.0	94.2	90.4	86.3
10000	89.2	91.4	91.9	91.9	89.0	88.9	85.4	87.7	89.2	91.4	93.0	94.2	94.9	91.2	88.2	83.8

TABLE XIII. - NOISE OF QF-1A CONFIGURATION 81 (ACTIVE SHORT STATOR,
ACTIVE INLET WITH RINGS, INACTIVE EXHAUST DUCT)

[Data adjusted to standard day of 25⁰ C and 70 percent relative humidity;
SPL re 2×10⁻⁵ N/m².]

(a) 60 Percent of design speed.

FREQUENCY	ANGLE, DEG															
	10	20	30	40	50	60	70	80	90	100	110	120	130	140	150	160
1/3-OCTAVE BAND SOUND PRESSURE LEVELS (SPL) ON 45.7 METER RADIUS																
50	72.0	69.3	70.0	70.3	68.5	68.0	68.3	69.5	71.3	70.5	71.3	71.0	70.3	71.8	74.0	74.9
63	69.3	69.0	69.0	68.8	68.3	68.5	67.8	67.3	67.5	68.0	68.8	70.0	71.8	72.5	74.0	75.4
80	72.0	72.3	71.5	71.3	69.0	69.0	66.5	68.3	68.5	68.8	70.8	71.5	73.3	75.3	75.8	76.9
100	77.2	77.0	76.7	76.7	74.2	73.7	72.5	72.7	72.7	72.7	73.5	74.7	76.0	76.7	78.2	78.1
125	79.8	80.3	80.6	79.6	76.8	77.1	75.6	74.6	76.1	76.3	77.3	78.1	78.1	78.6	79.8	77.9
160	80.5	80.7	79.5	78.2	76.7	75.5	77.0	75.7	77.0	76.5	78.5	79.2	78.0	79.0	77.7	77.4
200	80.8	81.0	79.5	76.3	75.5	74.3	73.5	74.3	75.5	75.3	76.8	77.0	78.5	78.3	78.0	77.2
250	81.0	82.7	80.7	78.2	78.2	78.0	77.2	78.7	80.7	82.2	83.0	84.0	83.5	81.7	78.7	76.8
315	80.4	80.4	78.9	78.4	78.9	79.2	78.2	78.9	80.7	82.4	83.4	83.9	82.2	80.2	79.4	78.1
400	78.0	77.7	77.5	76.7	77.5	78.0	77.5	79.5	81.2	83.5	85.0	86.0	84.2	81.5	79.0	76.9
500	76.9	76.9	75.9	75.4	74.9	75.9	76.7	78.7	80.9	82.9	84.2	85.0	83.2	81.7	78.4	76.8
630	74.2	74.7	73.9	73.4	72.9	73.9	75.2	76.4	78.7	80.9	81.9	82.7	82.2	81.4	77.7	75.6
800	71.5	71.7	72.0	72.7	72.0	73.0	74.5	75.5	78.5	80.2	82.0	82.0	82.2	82.0	76.7	74.1
1000	70.9	70.6	70.9	70.6	70.6	71.9	73.4	74.9	77.6	79.1	80.6	82.1	81.6	81.4	75.9	73.8
1250	71.1	69.9	69.9	69.4	70.1	70.9	73.1	74.6	77.4	78.4	81.6	82.6	81.4	81.4	76.9	73.5
1600	78.1	76.1	73.4	72.1	71.6	71.6	74.4	75.6	78.6	81.6	82.9	84.1	86.1	86.1	79.6	75.0
2000	82.8	82.8	79.3	76.6	75.1	75.8	76.8	77.8	82.1	88.6	86.6	88.6	93.1	94.6	86.8	80.9
2500	71.6	71.4	69.6	69.4	68.6	69.1	70.1	73.2	76.1	79.1	80.6	81.7	82.6	80.9	75.9	71.8
3150	75.9	75.9	73.2	70.9	69.9	69.6	70.9	74.1	76.6	78.9	81.1	82.9	84.1	81.9	76.9	73.0
4000	81.0	81.0	78.7	76.5	73.7	71.1	71.3	74.8	77.3	79.6	82.8	83.3	86.6	85.6	79.7	74.5
5000	79.0	78.7	78.2	76.0	71.7	69.2	69.9	72.7	75.7	77.2	80.4	80.7	82.4	81.4	77.2	71.6
6300	81.5	80.9	79.5	77.7	74.7	71.9	69.5	72.3	74.8	78.0	79.7	82.0	84.3	81.3	77.0	72.7
8000	80.9	81.7	80.4	79.4	76.7	72.2	68.6	71.9	74.9	76.9	79.1	79.9	82.4	81.4	76.6	70.3
10000	79.8	80.7	80.5	79.8	77.0	71.9	67.8	69.2	71.7	74.0	76.2	77.8	79.7	78.0	75.0	68.5

TABLE XIII. - Continued.

(b) 70 Percent of design speed.

FREQUENCY	ANGLE, DEG															
	10	20	30	40	50	60	70	80	90	100	110	120	130	140	150	160
1/3-OCTAVE BAND SOUND PRESSURE LEVELS (SPL) ON 45.7 METER RADIUS																
50	74.0	72.0	72.8	72.5	71.5	71.8	72.3	73.5	74.8	74.2	75.2	75.2	74.7	76.0	77.3	78.9
63	71.8	72.1	70.9	70.8	70.3	70.4	70.9	70.8	71.4	72.1	73.6	73.4	75.1	76.6	78.9	79.5
80	76.1	76.6	74.6	71.5	71.6	70.1	71.0	71.0	71.8	73.1	75.1	76.2	77.6	79.3	80.3	82.0
100	81.7	80.3	79.3	77.8	75.8	75.8	74.8	75.3	76.7	77.0	78.5	79.6	80.8	81.7	83.3	82.9
125	83.6	83.6	82.6	81.1	80.5	79.8	79.6	80.1	80.3	82.1	83.0	83.1	83.8	83.8	84.5	83.0
160	82.7	82.7	81.7	80.3	79.8	79.8	80.7	80.2	82.2	82.0	83.5	83.6	83.3	83.2	82.5	82.9
200	83.0	82.6	80.5	78.3	78.8	78.6	78.0	79.1	79.6	80.3	82.3	82.2	83.0	83.0	82.6	81.9
250	80.2	82.6	80.9	80.2	80.7	80.7	81.7	83.2	85.4	87.1	88.6	88.8	88.4	86.4	83.9	81.6
315	79.5	80.1	80.5	82.1	82.8	83.1	82.8	84.5	86.5	88.0	89.1	88.7	87.5	85.1	84.0	83.0
400	79.1	80.0	80.5	80.1	81.6	83.0	83.6	85.3	87.0	89.0	90.0	90.2	89.5	86.6	83.6	81.9
500	78.8	79.3	78.8	79.5	79.8	81.6	82.1	84.6	86.6	88.5	90.1	89.9	88.8	86.5	84.1	82.0
630	77.3	77.5	77.5	77.5	78.5	79.8	81.2	83.0	85.2	87.2	88.8	88.6	88.0	86.5	83.0	81.0
800	75.2	75.9	76.2	77.2	78.0	78.5	80.4	82.7	84.4	86.2	87.9	88.5	88.2	86.5	82.2	79.9
1000	75.0	75.1	75.5	75.8	76.1	78.1	79.6	81.6	83.6	85.1	87.1	88.7	88.0	86.0	81.1	79.9
1250	74.6	74.7	74.9	75.1	76.2	77.1	79.6	81.1	83.9	84.6	87.6	88.8	87.6	85.6	81.7	79.3
1600	75.3	75.1	74.6	75.1	76.3	76.9	79.4	81.1	83.9	85.8	87.9	88.2	88.3	85.6	81.4	78.5
2000	80.3	81.7	79.8	79.6	78.6	79.6	81.1	82.8	85.9	89.2	93.2	92.4	94.5	91.7	87.5	83.4
2500	77.2	77.8	76.5	76.2	76.2	76.8	78.3	81.0	84.2	87.5	89.5	90.3	91.7	89.3	85.0	81.9
3150	78.4	77.4	75.1	74.6	74.8	75.9	77.4	80.8	83.4	85.6	87.9	89.2	89.8	86.1	81.3	78.7
4000	83.3	82.3	81.8	80.3	77.6	76.9	78.1	81.6	84.1	86.2	88.9	89.5	91.2	88.1	83.3	78.8
5000	81.4	80.9	80.9	79.6	75.6	74.6	76.4	79.8	82.3	84.3	86.9	87.2	88.4	86.3	82.4	77.7
6300	84.8	84.3	82.4	81.8	79.7	78.1	75.6	78.6	80.9	84.9	85.9	88.4	89.9	85.7	80.7	78.2
8000	83.3	84.2	82.5	81.7	78.7	76.3	74.3	78.3	81.6	83.1	85.3	85.9	87.6	85.3	81.3	76.4
10000	83.5	84.8	83.9	83.1	80.2	77.7	73.5	76.4	78.4	80.6	82.4	83.8	85.3	81.6	79.3	74.3

TABLE XIII. - Continued.

(c) 80 Percent of design speed.

FREQUENCY	ANGLE, DEG															
	10	20	30	40	50	60	70	80	90	100	110	120	130	140	150	160
1/3-OCTAVE BAND SOUND PPESSURE LEVELS (SPL) ON 45.7 METER RADIUS																
50	82.1	75.6	79.4	80.4	80.9	80.3	77.4	76.8	77.4	77.9	78.4	77.8	78.6	80.4	82.8	82.6
63	72.4	73.9	72.6	72.9	73.1	72.9	73.2	73.6	74.4	74.9	76.4	77.2	78.7	80.9	81.7	82.6
80	76.1	77.3	74.3	72.4	72.3	72.6	73.4	73.8	74.9	76.1	78.3	79.8	81.1	82.8	84.6	85.1
100	81.1	79.5	78.5	77.8	76.8	77.3	77.3	78.1	80.1	81.3	82.1	82.9	84.6	85.3	87.6	86.9
125	81.5	81.8	81.2	80.8	80.3	81.3	82.0	83.0	84.3	85.5	86.8	87.2	87.5	87.8	88.7	86.7
160	81.5	82.0	82.5	81.9	81.9	84.5	84.5	85.0	86.7	87.4	88.0	88.3	88.2	88.0	86.7	86.7
200	82.3	83.8	83.1	80.6	82.6	83.5	82.5	83.8	84.0	84.5	85.3	86.2	87.0	87.1	86.8	86.0
250	80.7	82.2	82.0	81.7	83.0	83.5	85.2	85.7	88.4	89.5	90.9	91.6	91.5	90.0	87.7	85.6
315	81.0	82.7	83.4	84.4	85.5	86.2	86.9	88.5	90.2	91.0	92.7	92.3	90.9	88.9	87.5	86.6
400	81.2	82.0	83.4	83.9	85.0	87.2	88.2	89.5	91.0	92.2	93.0	93.6	92.5	90.0	87.5	86.3
500	81.4	82.2	82.2	83.2	84.6	85.9	87.4	89.4	91.2	92.6	93.4	93.7	92.7	90.4	88.1	86.5
630	80.9	81.7	81.7	82.4	83.4	85.5	86.9	88.9	90.5	92.2	93.4	93.6	93.7	91.0	87.5	85.8
800	79.8	80.3	80.8	81.8	82.5	84.0	86.0	87.8	89.3	90.8	93.2	94.3	94.8	91.8	87.2	85.2
1000	79.1	80.1	80.1	80.9	81.4	83.8	85.6	87.3	89.4	90.3	92.9	94.8	94.4	90.9	86.6	84.8
1250	78.6	78.9	79.6	79.9	80.8	82.4	84.9	86.4	89.4	90.4	93.8	94.9	94.3	91.1	87.3	84.8
1600	78.5	78.8	79.0	79.8	81.3	82.5	84.7	87.0	89.7	91.2	94.0	94.6	94.5	91.0	87.0	83.9
2000	81.5	79.5	80.5	80.1	81.3	82.5	84.5	86.9	89.9	92.8	94.4	94.6	94.8	91.3	87.8	84.2
2500	83.5	82.6	83.3	82.5	82.6	83.0	84.1	87.5	90.3	93.6	96.0	97.7	99.3	95.1	90.6	87.4
3150	81.4	80.1	79.4	79.3	79.9	81.8	83.1	86.6	89.1	91.1	93.4	95.4	95.8	91.8	87.6	84.5
4000	83.0	83.0	82.2	81.2	80.2	81.6	83.4	86.7	89.2	91.2	94.1	94.4	95.6	91.4	87.2	83.3
5000	85.3	85.6	86.9	86.4	81.9	80.9	82.6	85.1	87.8	89.8	92.4	93.2	94.1	91.3	87.6	82.7
6300	85.9	86.3	84.6	83.3	81.4	82.1	80.4	84.3	86.4	89.8	90.7	93.4	95.1	89.4	85.2	82.9
8000	86.6	87.6	86.3	85.6	83.1	81.9	80.1	83.9	86.8	88.4	90.2	91.2	92.7	89.7	86.1	81.0
10000	85.7	86.7	86.3	85.5	82.6	81.1	78.4	82.0	83.7	86.0	87.9	88.9	90.3	86.5	83.7	79.0

TABLE XIII. - Concluded.

(d) 90 Percent of design speed.

FREQUENCY	ANGLE, DEG															
	10	20	30	40	50	60	70	80	90	100	110	120	130	140	150	160
1/3-OCTAVE BAND SOUND PRESSURE LEVELS (SPL) ON 45.7 METER RADIUS																
50	80.7	76.0	76.0	81.5	77.3	82.7	78.8	77.3	81.2	81.8	83.0	83.1	81.2	83.2	84.5	87.2
63	75.2	76.1	75.4	76.4	75.9	76.6	76.9	75.9	76.7	77.7	79.6	80.5	81.7	83.9	84.7	86.3
80	77.9	79.1	76.4	74.6	74.6	75.2	75.2	75.6	77.4	79.1	80.6	82.3	84.7	85.9	88.4	89.3
100	85.7	85.0	83.0	82.7	80.8	80.2	80.2	82.3	82.5	84.0	86.5	86.6	88.2	89.7	91.0	90.5
125	84.6	84.6	83.9	83.3	82.3	82.8	83.4	84.4	86.1	87.3	88.4	89.4	90.8	91.3	91.9	90.8
160	83.5	85.3	85.5	84.5	84.5	86.3	86.8	88.3	89.5	89.8	90.1	91.7	91.1	90.8	90.0	90.7
200	84.5	86.0	85.1	83.8	84.8	85.0	85.0	86.0	86.3	86.8	87.6	88.6	89.1	89.0	89.5	89.7
250	83.2	84.8	85.5	85.0	85.2	86.2	87.0	87.7	90.3	91.5	92.8	93.4	93.7	92.8	91.2	89.1
315	83.4	85.6	86.1	86.9	88.1	88.7	89.6	91.2	93.1	94.2	94.7	94.7	92.9	92.1	90.7	90.0
400	83.4	84.6	85.8	85.9	86.8	89.1	89.4	91.1	92.8	93.8	95.4	95.5	94.8	92.3	91.1	89.6
500	84.2	85.2	85.2	86.4	87.2	89.1	90.1	91.9	93.4	94.4	95.4	95.5	95.2	92.6	91.1	89.6
630	84.0	84.6	84.6	86.0	86.5	89.0	90.5	91.8	94.1	95.8	96.1	96.5	96.0	93.5	91.1	88.7
800	83.2	84.0	84.3	85.7	86.0	87.8	89.8	91.7	92.8	94.3	96.3	97.6	98.7	95.0	90.8	88.9
1000	82.6	83.6	84.4	85.3	85.9	88.1	89.6	91.6	93.8	94.6	97.9	98.4	98.3	94.3	90.4	89.5
1250	82.0	82.8	83.8	84.0	85.0	86.8	89.1	91.1	94.1	95.5	98.0	98.9	98.5	95.3	91.5	89.2
1600	81.6	82.3	82.6	83.6	85.3	86.8	88.8	90.4	93.4	95.1	97.8	98.4	98.8	94.9	90.9	88.1
2000	81.8	82.3	83.2	83.7	85.6	86.9	88.8	90.8	93.8	96.2	97.9	98.1	99.2	94.4	91.4	88.2
2500	86.0	85.7	85.5	85.2	85.7	86.5	88.3	90.5	94.2	97.0	98.3	99.8	100.2	95.7	91.5	88.2
3150	86.6	86.4	85.4	84.9	85.7	86.6	88.1	90.9	93.7	95.9	97.9	100.0	100.6	96.6	92.2	89.5
4000	85.5	85.8	85.0	84.5	84.7	85.9	87.9	91.2	93.6	95.6	98.1	98.5	99.2	95.2	91.1	87.3
5000	86.8	87.6	87.9	86.6	83.9	84.6	86.7	89.7	92.6	93.8	96.6	96.9	97.1	93.6	90.6	86.4
6300	87.9	89.0	88.0	86.9	85.2	86.2	85.2	88.2	90.9	94.0	94.9	97.5	98.5	93.2	89.4	87.1
8000	88.3	89.4	88.5	88.1	85.3	85.1	84.8	88.4	91.3	92.9	94.3	95.1	96.3	92.8	89.6	85.2
10000	86.2	87.9	87.7	87.0	83.7	83.4	82.5	86.2	88.0	90.4	91.9	93.0	93.9	89.9	87.5	82.9

TABLE XIV. - NOISE OF QF-1A CONFIGURATION 82 (ACTIVE LONG STATOR,
ACTIVE INLET WITH RINGS, INACTIVE EXHAUST DUCT)

[Data adjusted to standard day of 25⁰ C and 70 percent relative humidity;
SPL re 2×10⁻⁵ N/m².]

(a) 60 Percent of design speed.

FREQUENCY	ANGLE, DEG															
	10	20	30	40	50	60	70	80	90	100	110	120	130	140	150	160
	1/3-OCTAVE BAND SOUND PRESSURE LEVELS (SPL) ON 45.7 METER RADIUS															
50	71.1	66.9	68.6	68.2	68.2	67.7	69.9	68.4	70.4	69.4	70.2	70.3	70.1	71.9	73.1	74.9
63	67.4	67.7	66.9	66.6	66.9	68.1	67.9	66.7	69.1	68.1	68.2	69.5	70.9	72.4	73.9	75.9
80	70.7	71.1	68.9	66.7	65.7	69.4	67.7	65.9	68.4	68.7	70.1	71.6	73.4	74.1	75.9	75.9
100	75.0	73.7	72.4	71.4	70.0	69.2	69.0	70.0	70.2	71.5	72.2	73.1	74.0	75.7	76.7	76.9
125	75.4	75.8	75.1	74.1	73.4	71.9	72.3	72.1	72.8	74.4	74.1	75.4	76.3	76.8	77.1	76.0
160	75.6	76.2	75.6	73.4	74.2	73.7	73.7	73.1	74.6	74.9	75.6	77.0	76.4	76.7	76.6	76.0
200	75.7	77.2	74.1	71.2	70.4	70.7	71.1	71.2	71.4	71.7	72.9	74.0	74.4	74.9	74.9	74.5
250	75.0	76.2	73.7	72.5	70.0	69.8	69.8	70.7	71.7	73.3	74.5	76.3	76.8	75.7	75.2	73.9
315	76.0	76.0	73.5	72.6	72.0	71.8	72.8	73.7	74.0	75.3	76.2	77.4	77.5	76.3	76.2	74.9
400	74.5	74.2	73.7	72.0	70.3	70.7	71.2	72.0	74.3	76.0	77.2	79.1	79.5	77.5	75.8	73.9
500	74.1	73.9	73.1	70.9	70.6	70.6	71.2	73.1	74.4	75.9	76.2	77.3	77.1	77.2	75.2	73.5
630	72.7	73.0	71.2	69.8	69.8	69.5	70.5	71.7	73.0	74.5	76.0	76.9	77.7	77.2	74.7	72.9
800	70.0	70.2	69.0	68.8	68.5	68.7	69.8	71.7	72.3	73.8	75.7	77.6	78.8	79.3	74.7	72.9
1000	69.9	68.7	67.6	67.2	66.7	67.2	68.4	69.6	71.1	72.9	74.7	76.8	78.1	78.4	73.6	71.8
1250	69.3	68.3	67.0	66.2	66.2	67.0	68.2	69.7	70.8	72.3	74.2	75.6	77.3	77.0	73.0	71.4
1600	75.1	74.6	72.1	69.9	68.3	67.9	68.3	69.3	70.8	72.6	75.1	76.4	78.8	78.9	74.6	73.3
2000	82.3	83.3	80.8	77.3	75.8	74.8	71.9	71.9	73.1	77.1	78.4	81.2	83.8	87.3	82.8	79.3
2500	71.3	71.3	69.5	67.5	66.1	65.6	66.1	67.5	69.0	70.1	71.8	73.7	75.5	74.6	72.8	70.2
3150	76.2	75.7	72.6	70.7	68.1	66.6	66.1	68.4	69.1	70.2	72.2	74.8	76.2	75.9	74.2	70.6
4000	81.7	81.4	79.0	78.2	73.5	70.0	68.7	70.2	70.7	72.4	75.7	77.3	80.2	79.9	80.4	73.5
5000	79.3	79.3	78.7	76.3	71.8	69.2	69.5	71.5	73.2	75.3	78.8	81.0	84.5	82.7	82.3	75.4
6300	82.4	81.8	79.9	78.0	75.7	72.3	69.6	71.7	72.9	75.4	78.7	82.9	86.6	86.1	82.2	75.8
8000	81.7	83.0	80.5	79.9	77.0	72.5	68.5	71.2	72.8	74.7	77.0	79.6	82.2	82.7	80.3	73.2
10000	80.5	81.5	80.6	79.8	77.7	73.0	67.4	69.2	69.9	71.4	74.0	76.2	77.3	76.6	75.3	67.3

TABLE XIV. - Continued.

(b) 70 Percent of design speed.

FREQUENCY	ANGLE, DEG															
	10	20	30	40	50	60	70	80	90	100	110	120	130	140	150	160
	1/3-OCTAVE BAND SOUND PRESSURE LEVELS (SPL) ON 45.7 METER RADIUS															
50	73.3	70.6	71.9	72.1	71.9	72.3	72.3	74.3	73.6	73.9	75.6	75.5	75.4	76.4	78.3	79.5
63	69.9	71.6	70.6	70.1	69.8	69.9	70.4	71.4	70.9	71.8	73.9	74.4	75.3	76.9	79.4	80.2
80	73.1	75.5	72.6	70.0	70.6	72.1	72.8	73.1	71.8	73.8	77.6	77.1	78.6	79.6	80.8	81.9
100	77.8	77.4	76.6	75.6	73.6	73.3	74.1	72.9	74.9	75.9	77.3	78.5	80.1	80.9	81.8	81.6
125	79.8	80.0	80.3	79.0	77.3	77.1	78.1	77.8	78.3	79.5	80.1	80.6	81.6	82.3	82.5	82.0
160	79.2	79.0	78.8	78.8	77.0	77.7	78.3	77.8	79.2	79.5	80.3	81.4	81.2	81.2	81.3	80.7
200	78.5	78.9	77.4	74.9	75.4	74.9	75.5	75.4	75.7	77.0	77.7	78.4	79.0	80.0	80.5	79.2
250	78.4	79.7	77.4	75.4	74.5	74.0	75.2	75.7	77.4	78.5	80.0	80.6	81.4	80.9	80.5	79.4
315	78.3	77.9	76.3	76.4	77.1	76.8	77.9	78.6	79.1	80.4	81.6	82.4	82.1	81.6	80.8	79.6
400	76.3	76.6	76.6	75.8	75.3	76.0	76.3	77.0	79.1	80.3	81.8	82.4	83.1	81.8	80.0	78.7
500	75.4	76.1	75.6	74.8	75.3	75.6	76.6	77.9	79.3	80.1	81.1	82.0	83.1	82.4	79.9	78.6
630	74.5	75.0	74.0	73.9	74.4	74.4	75.9	77.2	78.7	79.7	80.9	81.8	83.2	82.7	79.7	78.1
800	73.1	73.4	73.2	73.1	73.4	74.1	75.4	76.4	77.6	79.2	80.7	82.7	83.4	82.9	79.2	77.1
1000	73.3	72.3	72.0	71.7	72.0	73.2	74.3	75.0	77.0	78.3	80.3	82.3	83.2	82.3	78.0	76.9
1250	72.6	72.0	71.0	71.0	71.1	72.5	73.8	74.8	76.6	77.8	79.8	81.2	82.0	80.8	77.3	75.4
1600	73.6	73.1	72.6	71.6	71.5	71.8	73.5	73.8	75.8	77.1	78.8	79.7	81.5	79.5	77.0	75.0
2000	80.0	80.2	79.0	76.7	75.3	74.6	74.6	75.1	77.4	80.3	82.8	83.8	87.0	84.0	82.7	80.4
2500	77.2	77.3	76.2	74.3	73.0	72.7	73.0	73.7	75.2	77.3	80.2	81.6	84.0	81.8	80.3	78.1
3150	77.4	76.9	74.4	72.7	71.9	70.9	71.2	72.9	74.0	75.4	77.2	79.6	80.7	78.5	76.2	73.4
4000	82.1	82.8	81.5	79.6	76.1	73.5	73.1	74.8	75.3	76.3	79.1	80.3	83.0	81.0	80.6	76.4
5000	81.1	81.9	81.6	79.7	75.6	73.1	73.7	75.4	76.7	78.1	81.3	82.6	83.6	81.9	80.7	76.0
6300	85.0	85.0	83.5	82.0	80.2	78.6	76.0	78.0	80.0	83.8	86.6	90.8	93.7	89.7	85.7	79.9
8000	83.2	84.7	82.9	82.1	79.4	76.2	74.4	77.1	79.1	81.2	84.3	86.3	88.4	88.6	85.5	78.8
10000	83.6	85.0	84.4	83.1	80.7	77.2	73.5	75.1	76.1	78.1	80.3	82.1	83.8	81.7	80.1	72.4

TABLE XIV. - Continued.

(c) 80 Percent of design speed.

FREQUENCY	ANGLE, DEG															
	10	20	30	40	50	60	70	80	90	100	110	120	130	140	150	160
1/3-OCTAVE BAND SOUND PRESSURE LEVELS (SPL) ON 45.7 METER RADIUS																
50	83.4	76.4	78.5	79.5	80.4	79.5	78.5	81.9	78.4	79.7	80.5	79.1	81.9	81.2	83.9	83.4
63	71.9	73.2	73.1	73.1	72.9	73.2	73.1	74.6	74.6	74.7	75.9	77.3	79.9	81.2	83.7	84.0
80	74.4	74.4	72.8	72.6	71.6	72.6	72.4	73.9	73.4	75.3	77.1	79.2	81.8	83.8	85.4	86.0
100	79.4	78.0	78.2	78.9	75.5	76.0	77.2	77.2	77.7	79.2	80.9	82.8	83.7	85.2	87.4	86.4
125	79.7	79.9	79.9	79.2	78.1	78.9	79.2	80.2	80.7	82.4	82.9	84.0	84.9	85.6	87.2	85.9
160	79.3	80.9	80.4	79.9	79.6	80.6	80.9	82.3	82.8	83.6	84.1	84.9	85.1	85.3	85.6	85.0
200	79.8	80.3	79.3	78.4	78.8	79.1	79.3	79.6	80.6	80.9	81.8	82.9	83.8	84.3	85.3	84.0
250	78.5	79.6	78.3	78.5	78.1	79.0	79.5	80.6	82.5	84.1	86.0	86.6	87.0	86.0	86.5	84.3
315	79.0	79.8	80.0	80.8	81.1	81.8	82.3	83.5	84.3	86.0	87.0	87.4	87.6	87.0	86.6	84.8
400	78.9	79.5	80.2	80.2	79.9	81.7	81.7	82.7	84.5	85.7	87.5	88.3	89.4	87.5	86.5	84.9
500	79.1	79.0	79.6	79.5	80.6	81.1	82.3	84.1	85.6	86.0	86.8	87.4	88.3	87.0	85.8	83.9
630	77.8	78.8	78.3	78.8	79.3	80.1	81.8	83.0	84.5	86.0	87.1	88.1	89.0	87.8	85.5	83.4
800	76.6	77.1	77.3	77.3	78.3	78.9	80.8	81.6	82.9	84.6	85.9	87.5	88.9	86.9	84.1	81.8
1000	76.3	75.9	75.9	76.6	76.8	78.6	79.8	80.6	82.3	84.4	85.6	87.4	88.1	85.9	83.1	81.3
1250	75.9	75.1	75.3	75.6	75.9	77.4	79.3	80.3	81.6	83.6	85.3	86.4	87.3	84.6	82.3	80.3
1600	75.7	75.2	74.9	75.0	75.9	76.7	78.4	78.4	80.5	81.9	83.9	85.1	86.9	83.9	81.7	79.3
2000	78.1	76.6	75.8	75.8	75.9	76.6	77.5	78.3	80.6	81.9	83.9	84.7	86.6	83.3	81.1	79.2
2500	82.6	82.6	83.1	81.8	78.3	78.3	78.3	79.9	81.6	84.1	86.9	89.2	91.9	90.4	84.8	83.7
3150	80.0	79.3	77.1	76.0	75.5	76.1	76.1	77.8	79.5	81.1	82.6	84.9	86.1	82.6	80.3	77.5
4000	82.5	82.2	80.7	78.9	76.9	76.4	76.9	78.2	79.8	81.3	83.5	84.4	86.3	83.0	80.5	77.4
5000	85.3	85.6	87.1	86.4	81.4	79.1	78.6	78.9	80.3	81.4	84.1	84.7	86.3	84.3	82.8	78.9
6300	85.9	86.0	84.0	82.5	80.7	79.7	77.4	79.2	80.7	83.6	85.1	87.9	88.4	84.1	81.7	77.3
8000	86.8	88.1	86.1	86.0	83.5	81.6	78.6	80.3	82.4	84.8	87.1	88.6	90.1	87.8	85.3	79.6
10000	85.5	86.8	85.9	85.1	82.3	80.6	77.2	78.7	80.0	82.3	83.6	85.3	85.4	82.8	81.8	75.3

TABLE XIV. - Concluded.

(d) 90 Percent of design speed.

FREQUENCY	ANGLE, DEG															
	10	20	30	40	50	60	70	80	90	100	110	120	130	140	150	160
	1/3-OCTAVE BAND SOUND PRESSURE LEVELS (SPL) ON 45.7 METER RADIUS															
50	84.4	77.9	78.9	81.3	76.6	83.9	77.9	79.1	79.9	80.1	81.3	80.9	81.8	84.1	85.9	87.1
63	76.4	77.3	75.6	75.9	74.9	77.3	76.6	76.1	77.1	78.1	79.4	80.9	82.6	84.1	86.4	88.0
80	76.4	76.8	74.6	73.4	74.8	74.8	75.4	75.6	77.9	79.1	80.4	82.5	85.3	86.6	89.1	90.0
100	83.3	82.6	80.8	79.8	80.4	82.8	80.8	80.6	83.9	84.8	85.1	86.5	88.8	89.3	91.1	90.6
125	84.1	83.7	83.7	82.6	82.7	82.9	83.6	84.6	85.6	86.4	87.4	88.2	89.4	90.2	90.6	89.5
160	82.9	83.9	84.9	83.9	84.3	84.6	85.4	86.4	87.3	87.9	88.4	89.0	89.3	89.1	89.3	89.3
200	83.6	84.4	83.3	81.9	83.1	82.8	83.3	83.9	84.3	85.3	85.9	86.7	87.8	88.3	88.8	88.5
250	82.5	83.8	83.3	82.7	83.8	84.5	85.2	86.0	88.3	89.7	90.7	90.9	90.8	90.5	90.7	89.6
315	83.0	85.0	85.5	86.2	86.5	86.9	87.9	88.5	89.4	90.5	91.2	91.8	91.7	91.2	90.7	89.6
400	82.4	83.7	84.4	85.2	86.0	87.2	88.0	89.2	90.5	92.4	93.9	94.6	93.9	91.9	91.4	89.9
500	82.5	83.5	83.9	84.4	85.9	86.4	87.5	88.9	90.0	91.0	92.7	93.3	94.2	91.9	90.7	89.2
630	82.2	83.0	83.3	83.8	84.8	85.8	87.5	89.0	89.7	90.5	92.0	93.4	94.3	92.0	90.0	88.4
800	80.9	81.6	82.2	82.7	84.1	84.9	86.6	87.9	88.7	90.9	92.7	93.8	94.6	92.4	89.6	87.9
1000	80.2	80.1	80.9	81.7	81.9	83.6	85.4	86.2	87.6	89.6	91.9	93.0	93.7	90.6	88.2	86.8
1250	79.6	79.5	79.8	80.3	81.5	82.8	85.0	85.8	87.3	89.3	91.1	91.9	93.1	89.6	87.5	85.9
1600	79.1	78.6	79.1	80.0	81.1	82.3	84.1	84.6	87.0	88.5	90.5	91.6	92.3	89.5	87.0	84.9
2000	79.5	79.1	79.0	79.8	81.1	81.6	83.1	84.4	86.7	88.1	90.4	91.0	92.1	88.6	86.4	83.8
2500	84.9	83.8	83.3	82.4	82.1	81.8	82.4	84.1	86.4	88.3	90.4	91.5	92.1	88.1	85.8	84.7
3150	86.7	85.8	84.5	83.7	82.8	81.8	82.5	84.3	86.0	88.0	89.7	91.8	92.5	89.2	86.7	84.1
4000	85.4	85.1	83.1	81.7	80.7	80.8	81.8	84.5	85.7	87.3	89.2	90.1	91.5	88.0	85.5	82.1
5000	87.1	87.5	87.3	85.8	82.0	80.6	82.1	83.5	84.8	86.0	88.6	88.9	89.6	87.1	85.5	81.4
6300	88.6	88.9	87.6	87.1	84.1	83.1	81.4	83.0	84.2	86.6	87.7	90.3	91.7	87.9	85.0	80.8
8000	88.5	89.8	88.3	87.5	85.0	82.8	81.2	83.7	85.3	86.8	88.2	89.1	90.5	88.8	85.8	80.6
10000	86.9	88.0	87.6	86.1	83.6	82.0	80.1	82.0	82.7	84.7	86.0	87.4	87.5	85.2	83.9	77.7

TABLE XV. - NOISE OF QF-1A CONFIGURATION 83 (ACTIVE LONG STATOR,
INACTIVE INLET WITH RINGS, INACTIVE EXHAUST DUCT)

[Data adjusted to standard day of 25⁰ C and 70 percent relative humidity;
SPL re 2×10⁻⁵ N/m².]

(a) 60 Percent of design speed.

FREQUENCY	ANGLE, DEG															
	10	20	30	40	50	60	70	80	90	100	110	120	130	140	150	160
	1/3-OCTAVE BAND SOUND PRESSURE LEVELS (SPL) ON 45.7 METER RADIUS															
50	70.6	67.6	69.6	68.8	68.6	67.6	69.6	68.8	70.3	70.1	70.3	70.1	70.3	70.8	73.6	75.0
63	68.1	66.8	68.6	66.6	67.6	67.1	67.6	67.6	67.3	67.8	67.8	68.6	71.1	72.1	73.1	75.9
80	70.8	70.0	68.8	66.5	67.3	66.5	67.3	67.8	67.3	68.8	69.5	71.8	72.8	73.3	75.3	75.9
100	75.0	73.8	72.3	71.8	71.0	69.5	70.3	70.8	70.0	70.8	71.8	73.5	74.3	75.5	76.5	76.9
125	76.8	76.1	74.8	74.6	75.3	72.3	72.3	72.3	73.1	73.8	74.3	75.6	76.1	76.3	77.6	76.0
160	76.0	76.3	75.0	73.5	74.8	73.8	73.5	73.3	73.8	74.5	75.0	76.5	75.5	76.3	76.5	75.9
200	76.0	77.5	74.3	71.5	71.5	71.3	70.5	70.5	71.0	71.5	72.5	73.0	73.8	74.3	74.8	74.4
250	76.0	77.2	75.0	73.5	72.2	72.0	70.0	70.2	71.5	73.5	74.2	75.5	76.2	76.2	75.0	73.9
315	77.2	77.9	74.9	73.4	73.4	72.9	72.7	72.9	73.7	75.2	74.9	77.0	76.7	75.7	75.7	74.8
400	76.3	76.8	76.5	74.0	73.0	71.5	71.5	72.0	74.3	76.0	77.3	78.8	79.5	77.0	75.5	73.9
500	76.8	78.0	75.8	73.3	72.5	72.0	71.8	72.5	74.3	75.8	76.3	76.8	76.8	76.8	74.8	73.4
630	78.0	79.2	76.0	74.0	73.0	71.2	71.2	71.7	72.2	74.5	75.7	76.7	77.0	77.2	74.2	72.8
800	76.7	78.2	76.2	75.7	73.9	71.7	71.2	71.7	72.4	73.9	75.7	77.2	78.7	78.9	74.4	72.8
1000	78.1	79.1	77.1	75.9	74.9	71.9	70.6	70.4	71.1	72.9	74.1	75.9	77.6	78.1	73.6	71.7
1250	79.1	80.1	78.9	77.1	75.9	72.9	70.9	70.6	70.9	72.6	74.6	75.4	76.9	77.1	73.1	71.3
1600	85.6	86.9	85.8	83.5	81.6	79.5	74.9	73.6	72.9	74.1	75.4	76.6	78.4	78.1	75.4	73.3
2000	92.3	94.3	94.8	92.6	89.8	88.8	81.8	80.8	78.8	79.3	79.8	81.8	84.3	85.1	82.1	79.2
2500	82.0	83.7	83.7	82.0	80.0	77.0	73.2	71.5	71.2	71.5	72.7	74.0	75.2	74.7	73.5	70.1
3150	83.9	85.1	83.9	83.6	82.1	78.6	73.4	71.4	70.6	72.1	73.1	74.6	76.9	75.9	74.6	70.5
4000	87.1	89.3	87.8	88.5	87.3	82.3	77.6	74.3	73.8	74.5	76.5	77.3	80.3	79.8	79.8	73.4
5000	82.9	83.9	84.4	84.1	80.4	77.6	73.1	72.4	73.4	75.4	78.7	80.5	85.4	82.4	82.4	75.3
6300	84.0	84.2	83.7	83.2	82.0	79.7	72.9	72.2	72.7	75.9	78.4	82.5	86.4	86.2	81.7	75.9
8000	82.2	84.2	83.0	83.0	81.7	78.4	71.7	70.9	71.9	73.9	75.7	78.6	81.8	82.5	79.8	73.2
10000	79.9	81.6	81.4	81.4	79.6	76.4	69.4	68.9	69.2	71.2	73.2	75.5	78.1	76.4	74.9	67.6

TABLE XV. - Continued.

(b) 70 Percent of design speed.

FREQUENCY	ANGLE, DEG															
	10	20	30	40	50	60	70	80	90	100	110	120	130	140	150	160
	1/3-OCTAVE BAND SOUND PRESSURE LEVELS (SPL) ON 45.7 METER RADIUS															
50	72.7	71.2	71.2	71.7	71.7	71.0	72.2	72.5	73.4	73.2	72.9	73.3	74.9	76.2	77.9	79.4
63	70.0	71.4	70.2	70.2	71.2	69.7	70.7	70.2	71.4	71.0	71.9	73.1	75.2	76.9	78.9	80.1
80	74.8	75.4	72.4	71.9	71.1	69.1	70.1	71.8	72.4	73.3	74.6	75.9	77.9	78.8	80.6	81.8
100	77.6	76.8	76.8	75.1	73.4	72.6	73.4	73.3	74.1	75.8	76.9	78.0	80.3	80.3	81.4	81.6
125	80.2	80.2	80.2	79.1	77.9	78.1	77.7	77.4	77.7	78.9	79.4	81.0	81.4	81.2	82.1	82.0
160	79.7	79.9	79.0	78.4	77.9	77.0	77.7	77.4	78.5	78.7	80.2	80.6	81.2	81.0	80.7	80.6
200	79.1	79.6	77.5	74.6	75.3	74.3	74.8	75.0	75.8	76.5	77.0	78.4	79.1	79.0	79.8	79.2
250	78.9	80.6	77.9	76.3	75.3	74.4	74.8	75.9	76.9	78.3	79.6	80.5	81.4	80.8	80.4	79.3
315	79.0	79.7	76.9	76.9	76.9	76.5	77.2	78.4	78.9	79.9	80.9	81.6	81.7	80.5	80.5	79.6
400	78.5	79.0	79.7	77.4	76.2	76.0	76.2	77.0	78.4	80.2	81.0	82.3	83.0	81.2	79.9	78.6
500	78.4	79.6	78.2	76.6	76.6	75.7	76.1	77.4	78.6	80.1	80.7	81.6	83.1	82.1	79.7	78.6
630	78.8	79.8	77.8	76.9	75.9	75.4	75.8	77.4	78.1	79.3	80.3	81.5	82.4	82.3	79.4	78.0
800	78.8	80.6	79.5	77.6	76.5	75.1	75.6	76.6	77.3	78.8	80.4	82.4	82.9	82.6	78.8	77.0
1000	80.7	81.4	80.1	79.4	77.6	76.2	75.7	75.6	76.7	78.4	80.1	81.5	82.4	81.9	77.9	76.8
1250	81.4	82.9	81.6	80.2	78.4	76.4	75.4	75.6	76.1	77.7	79.6	80.8	81.4	80.6	77.4	75.3
1600	83.6	84.7	83.8	82.2	80.5	77.8	76.1	75.2	75.9	77.4	78.9	79.5	80.9	79.1	76.6	75.0
2000	92.2	96.6	94.4	96.4	96.3	88.9	84.9	81.7	80.4	81.0	84.9	83.0	86.7	84.4	83.7	80.3
2500	88.3	92.2	90.3	92.0	91.2	85.0	81.3	78.2	77.5	78.2	80.8	80.9	83.2	81.3	80.7	77.9
3150	85.5	86.8	86.0	85.5	84.2	81.2	77.3	75.5	75.2	76.2	77.2	79.1	81.0	78.3	76.7	73.4
4000	89.1	90.7	90.7	90.1	89.1	86.1	81.9	78.7	77.1	77.9	79.9	80.2	82.6	81.1	80.4	76.3
5000	86.0	87.5	88.6	88.0	85.5	82.8	79.3	77.3	77.6	78.7	81.5	82.1	84.2	81.5	80.0	75.9
6300	87.6	88.6	87.9	88.1	87.2	85.9	79.7	78.6	79.6	83.1	86.2	90.6	93.8	89.2	84.8	79.9
8000	85.3	87.3	86.3	86.9	85.1	82.6	77.6	77.4	78.9	80.4	83.0	85.5	87.3	87.7	84.8	78.8
10000	83.7	85.5	84.8	85.0	83.3	81.2	75.3	75.3	76.0	77.7	79.7	81.3	83.5	80.7	79.1	72.6

TABLE XV. - Continued.

(c) 80 Percent of design speed.

FREQUENCY	ANGLE, DEG															
	10	20	30	40	50	60	70	80	90	100	110	120	130	140	150	160
	1/3-OCTAVE BAND SOUND PRESSURE LEVELS (SPL) ON 45.7 METER RADIUS															
50	82.8	73.7	81.5	79.8	84.5	79.8	82.5	82.3	80.3	81.8	82.2	80.6	82.0	81.5	82.7	83.4
63	71.0	72.9	73.4	72.7	73.0	72.7	73.4	73.2	74.4	74.4	75.7	76.8	79.4	80.5	82.2	83.9
80	74.1	74.8	72.4	71.4	72.3	71.8	72.4	72.6	73.4	75.1	77.4	79.2	81.4	83.1	84.9	86.0
100	79.6	78.3	77.4	77.3	76.4	77.4	78.1	77.6	77.8	79.3	80.9	82.2	83.4	84.9	86.6	86.5
125	80.1	80.6	79.6	79.3	79.4	79.4	78.8	80.1	80.9	81.9	83.1	83.7	84.6	85.4	86.8	86.0
160	79.7	80.4	80.2	79.7	80.4	80.7	81.0	82.0	82.2	83.5	83.9	85.1	84.7	84.7	84.7	84.9
200	80.2	79.9	79.6	77.9	79.2	78.2	78.9	79.1	79.6	80.4	81.6	82.5	83.6	83.7	84.6	83.9
250	79.6	80.0	78.8	78.3	79.5	78.6	79.5	81.0	82.8	84.3	86.0	86.4	86.8	86.0	86.0	84.3
315	80.2	80.9	80.4	80.9	81.9	81.9	82.4	83.4	84.4	85.9	86.9	87.4	87.4	87.0	86.5	84.9
400	80.8	81.0	81.0	80.8	81.0	82.3	81.8	82.6	84.3	85.6	87.1	87.6	88.5	87.1	86.0	84.9
500	81.3	81.8	81.5	80.7	81.5	81.7	82.2	84.0	85.3	86.0	86.3	87.1	88.3	87.2	85.5	83.9
630	81.2	82.1	81.2	80.6	81.1	80.6	81.6	83.1	84.2	85.4	86.7	87.5	88.9	87.6	85.1	83.3
800	82.1	82.6	82.1	81.8	80.8	79.8	80.8	82.0	82.8	84.5	85.8	87.4	88.1	86.3	83.8	81.9
1000	82.4	82.9	83.6	82.3	81.1	79.9	79.9	81.1	82.1	83.9	85.3	87.0	87.4	85.8	83.1	81.3
1250	84.1	84.0	84.0	82.6	81.5	80.0	80.0	80.6	81.8	82.8	84.6	86.2	86.8	84.3	82.0	80.4
1600	85.3	85.8	86.3	84.9	83.4	81.1	80.1	79.6	81.3	81.9	84.1	84.7	86.3	83.4	81.1	79.3
2000	87.4	88.2	88.9	88.4	86.6	83.6	80.9	80.1	81.2	81.7	83.5	84.6	85.9	83.0	81.0	79.1
2500	96.7	98.2	99.2	102.4	98.7	95.9	90.9	88.2	87.6	86.7	88.2	89.7	91.7	91.1	86.4	83.6
3150	87.8	88.8	88.6	88.8	87.5	84.5	81.1	79.8	80.1	81.5	82.5	84.6	86.1	82.5	80.0	77.5
4000	88.2	89.8	89.8	89.3	87.5	84.7	81.2	80.3	80.3	81.2	83.3	84.2	86.0	83.0	80.8	77.4
5000	90.6	92.7	94.9	95.9	92.6	90.1	87.1	84.1	82.6	81.9	84.3	84.5	86.6	83.9	82.7	78.8
6300	88.6	89.4	89.1	88.9	87.8	86.1	80.9	80.3	81.1	83.1	85.0	87.7	88.9	84.2	81.6	77.4
8000	88.7	90.2	90.4	90.7	90.6	87.7	82.2	81.9	82.7	84.4	86.4	88.4	89.6	87.4	84.6	79.7
10000	86.3	87.6	88.3	88.1	86.9	84.4	79.6	79.6	80.1	81.6	83.3	84.8	86.1	82.3	81.3	75.6

TABLE XV. - Concluded.

(d) 90 Percent of design speed.

FREQUENCY	ANGLE, DEG															
	10	20	30	40	50	60	70	80	90	100	110	120	130	140	150	160
	1/3-OCTAVE BAND SOUND PRESSURE LEVELS (SPL) ON 45.7 METER RADIUS															
50	82.4	75.0	76.9	81.7	77.9	82.4	77.9	78.0	79.5	81.0	82.2	81.3	82.4	83.0	85.9	87.1
63	74.6	76.3	75.6	76.1	76.4	76.6	76.3	76.3	75.9	78.3	78.9	80.5	81.9	83.9	86.4	88.0
80	76.1	76.7	74.9	74.6	74.6	74.9	75.4	75.9	77.4	78.9	81.4	82.5	85.2	86.2	88.7	89.9
100	82.9	82.4	81.3	79.6	79.6	79.9	79.6	80.4	83.3	84.8	85.4	85.5	87.8	89.1	90.4	90.6
125	83.9	84.2	83.7	83.6	83.2	82.7	83.1	84.1	84.9	86.2	87.2	87.7	89.1	89.4	90.4	89.4
160	83.0	83.9	84.4	83.5	84.5	85.4	85.4	86.2	86.9	88.2	88.0	89.3	88.7	88.7	88.4	89.2
200	83.7	84.6	83.7	82.4	83.1	82.9	83.1	83.9	84.2	85.1	86.2	87.2	87.6	87.9	88.7	88.4
250	82.9	84.1	83.6	83.6	84.9	84.3	85.1	85.9	86.1	87.1	90.4	91.2	90.1	90.1	90.3	89.5
315	83.7	85.3	85.3	86.2	87.5	86.8	87.5	88.7	89.0	90.2	91.2	91.8	91.3	91.3	90.3	89.6
400	84.2	84.8	85.2	85.8	86.8	87.0	87.5	89.0	90.5	91.5	93.5	94.2	93.7	91.8	90.5	89.9
500	84.5	85.3	85.1	85.3	87.0	87.1	87.5	89.1	89.8	91.0	92.0	92.9	93.5	91.5	90.3	89.2
630	84.7	85.2	85.4	85.4	86.4	85.9	87.2	88.6	89.4	90.1	91.9	93.2	93.7	91.6	89.6	88.3
800	85.3	85.5	85.3	85.7	85.5	85.3	86.5	87.5	88.5	90.5	92.0	93.2	94.0	91.8	89.0	87.9
1000	85.2	85.6	85.2	85.6	85.6	85.1	85.6	86.2	87.9	89.4	91.4	92.6	93.6	90.4	87.9	86.8
1250	85.9	86.4	86.2	86.4	85.4	84.7	85.2	85.7	87.0	89.0	90.9	92.0	92.2	89.5	87.2	85.8
1600	87.3	87.8	88.0	87.2	86.3	84.7	84.6	84.8	86.5	87.7	89.8	90.9	91.7	89.0	86.8	84.7
2000	88.5	89.5	89.4	88.9	87.5	85.7	84.4	84.4	86.2	87.6	90.1	90.9	91.1	88.3	86.1	83.7
2500	94.2	96.5	97.2	99.4	97.5	94.7	90.5	88.2	87.9	88.5	90.4	91.3	91.5	88.2	86.2	84.6
3150	94.8	97.0	97.5	99.5	97.8	95.0	90.6	88.5	87.8	88.5	89.8	91.4	92.1	88.6	86.3	84.0
4000	91.1	92.4	91.4	91.7	89.7	87.2	84.6	84.2	85.2	86.6	89.1	89.5	90.6	87.7	85.1	82.0
5000	90.9	92.4	94.1	94.1	90.4	89.8	86.4	84.9	84.6	85.8	87.9	88.0	89.8	86.8	84.8	81.3
6300	91.6	92.1	93.1	93.0	91.1	90.4	85.7	84.4	84.1	85.9	87.4	89.7	91.4	87.1	84.2	80.8
8000	90.4	92.0	92.1	93.4	91.1	89.4	84.4	84.3	84.9	86.3	87.4	88.4	90.1	87.8	85.1	80.7
10000	87.8	87.3	89.6	90.1	87.8	86.7	81.5	82.1	82.3	84.1	85.6	86.3	87.5	84.1	83.0	78.0

TABLE XVI. - NOISE OF QF-1A CONFIGURATION 88 (ACTIVE LONG STATOR,
ACTIVE INLET WITH RINGS, ACTIVE EXHAUST DUCT)

[Data adjusted to standard day of 25⁰ C and 70 percent relative humidity;
SPL re 2×10⁻⁵ N/m².]

(a) 60 Percent of design speed.

FREQUENCY	ANGLE, DEG															
	10	20	30	40	50	60	70	80	90	100	110	120	130	140	150	160
	1/3-OCTAVE BAND SOUND PRESSURE LEVELS (SPL) ON 45.7 METER RADIUS															
50	68.6	67.2	67.7	67.2	67.2	66.2	66.1	67.2	67.7	69.7	68.6	69.0	70.2	70.4	72.6	72.8
63	66.4	66.7	66.6	65.2	66.4	66.6	65.4	64.9	66.6	67.4	66.6	68.3	70.1	70.9	72.9	73.1
80	69.8	69.9	66.9	65.4	66.3	67.9	64.9	66.3	67.6	67.3	68.6	70.4	71.9	73.8	74.4	74.1
100	73.0	71.9	70.7	70.5	69.4	69.7	70.0	69.5	68.5	70.9	71.9	72.3	74.0	75.5	76.0	75.6
125	75.4	75.4	73.9	74.3	73.4	71.3	71.9	71.4	71.6	73.9	74.1	74.7	75.6	75.8	76.8	75.8
160	75.0	75.5	74.9	73.2	72.9	72.2	72.5	72.4	73.2	74.5	74.7	76.0	75.5	75.9	75.9	74.9
200	74.9	76.4	73.4	71.1	70.1	69.6	69.9	69.9	70.6	71.4	72.1	73.0	73.4	73.6	74.6	73.8
250	74.0	75.2	72.7	72.0	70.2	69.5	69.0	70.0	71.2	73.0	74.0	74.9	75.5	74.8	74.7	72.6
315	75.3	75.3	73.5	72.7	72.5	71.7	72.5	73.2	74.3	75.3	76.0	76.8	76.3	75.7	75.0	73.6
400	73.6	73.7	73.7	72.4	70.4	70.6	70.4	71.1	72.6	74.1	75.2	77.0	77.4	76.1	74.9	72.3
500	73.4	73.1	72.9	70.4	70.1	69.1	70.4	71.7	72.7	73.6	74.1	74.8	75.9	75.7	73.7	71.6
630	72.0	72.3	71.0	68.6	68.5	68.5	68.8	69.8	70.3	72.0	73.3	74.2	74.8	76.0	72.8	70.5
800	69.5	69.3	68.8	68.0	67.8	67.2	68.2	68.7	69.5	70.8	72.2	73.6	74.8	75.5	72.0	69.4
1000	68.9	67.8	67.4	66.1	65.8	65.6	66.4	67.3	67.9	69.3	70.6	72.0	73.1	73.9	70.6	68.3
1250	68.9	66.9	66.8	65.3	64.9	64.8	65.8	66.8	67.3	68.6	69.4	70.5	71.6	71.3	68.9	65.8
1600	73.2	72.8	71.8	69.6	67.6	66.2	65.7	66.4	66.9	68.1	68.7	69.2	70.6	70.2	68.4	66.1
2000	80.1	82.9	79.8	76.6	75.1	71.6	68.1	68.4	68.3	69.1	70.1	70.9	71.8	71.9	70.4	67.8
2500	70.9	70.1	69.7	67.2	65.1	64.1	63.9	64.7	65.2	66.2	66.7	67.7	69.2	68.9	66.6	63.3
3150	75.1	74.1	73.1	70.4	67.6	65.6	64.2	65.2	65.6	66.7	66.7	68.5	70.2	69.7	67.6	63.8
4000	80.9	80.9	79.9	78.1	73.2	69.6	67.1	67.2	67.1	67.6	68.6	69.4	71.9	71.7	70.2	65.7
5000	78.7	78.9	78.7	76.2	71.2	67.7	66.5	66.5	67.2	68.0	71.2	73.8	77.9	75.4	74.9	67.1
6300	81.9	81.3	79.9	78.1	74.6	71.5	67.4	67.5	68.2	71.0	73.2	78.0	82.2	81.9	79.2	72.3
8000	81.3	81.9	80.6	79.6	76.1	72.6	67.4	67.4	68.2	70.7	72.4	75.8	78.8	76.6	74.3	68.4
10000	80.1	80.7	80.1	79.3	76.3	73.2	67.0	66.1	65.8	67.3	68.4	70.1	72.4	70.4	68.9	63.5

TABLE XVI. - Continued.

(b) 70 Percent of design speed.

FREQUENCY	ANGLE, DEG															
	10	20	30	40	50	60	70	80	90	100	110	120	130	140	150	160
	1/3-OCTAVE BAND SOUND PRESSURE LEVELS (SPL) ON 45.7 METER RADIUS															
50	72.3	70.7	70.8	71.0	71.0	69.8	71.3	72.2	72.8	73.7	73.0	73.6	74.5	76.7	78.7	78.0
63	69.5	70.5	69.8	69.3	69.8	69.3	69.5	69.5	70.5	71.8	72.0	73.0	75.5	77.1	78.5	79.3
80	74.2	73.5	72.0	69.5	70.0	69.8	69.7	69.2	70.7	72.5	74.2	75.4	76.8	79.0	80.5	80.5
100	77.6	76.8	75.3	74.0	72.1	72.1	72.1	72.1	73.5	76.0	76.1	77.6	79.3	80.8	81.0	80.9
125	79.7	80.3	79.5	78.7	76.8	76.5	75.7	75.5	77.2	78.2	79.0	79.4	81.5	81.5	81.8	80.9
160	80.1	79.6	78.8	78.3	76.9	76.6	77.4	76.8	78.9	79.1	79.8	80.5	80.9	81.1	80.4	79.6
200	78.8	78.9	76.6	74.8	74.9	74.3	74.4	74.8	74.9	76.4	76.9	77.7	78.4	78.8	79.4	78.3
250	77.9	78.4	76.4	75.0	73.7	74.0	74.4	75.4	76.7	78.9	79.7	80.3	81.5	80.5	80.7	78.6
315	76.6	77.1	76.2	76.1	76.2	76.7	77.4	78.7	79.1	80.9	81.4	81.8	81.6	81.1	80.6	78.3
400	75.8	75.8	76.1	75.3	74.6	75.3	75.4	76.4	77.4	79.8	80.4	81.2	82.4	80.9	79.6	77.3
500	74.9	74.9	74.6	73.4	74.1	74.1	75.2	76.2	77.4	79.1	79.2	80.5	81.7	81.4	79.2	76.6
630	73.8	73.8	73.0	72.7	73.2	73.2	74.2	75.7	76.2	78.2	79.0	80.1	81.3	81.0	78.3	76.1
800	72.7	72.5	72.0	71.9	72.2	72.4	73.4	73.9	74.9	77.0	78.0	79.3	80.9	80.2	77.4	75.3
1000	71.8	71.1	70.5	70.5	70.6	70.6	71.5	72.6	73.1	75.3	76.8	78.1	79.0	79.1	76.0	73.7
1250	72.0	71.0	70.3	69.7	69.8	70.0	71.3	72.2	73.0	74.7	75.5	76.8	77.5	77.0	74.8	71.9
1600	74.9	73.3	72.4	70.8	70.6	69.9	70.8	71.3	72.3	73.6	74.8	74.9	76.9	75.4	73.4	71.0
2000	80.5	80.5	78.0	75.7	73.4	73.1	72.3	71.4	72.8	74.4	75.4	76.0	77.8	76.1	73.9	71.3
2500	78.2	78.2	75.3	73.5	71.7	70.8	70.0	70.5	71.3	72.5	73.7	74.3	76.2	74.5	72.7	69.9
3150	77.8	76.3	73.9	71.8	70.9	69.6	69.6	70.4	70.6	72.4	72.4	74.0	75.9	73.6	71.6	68.7
4000	82.7	82.1	81.1	79.3	76.1	72.2	71.1	71.6	71.2	72.4	73.4	73.9	76.1	74.2	71.9	68.9
5000	81.7	81.5	81.5	79.5	75.4	71.7	70.9	71.2	71.9	73.1	74.6	75.2	77.6	73.9	71.9	68.5
6300	84.9	84.6	83.2	81.9	79.2	76.8	72.7	72.9	73.6	77.8	80.0	84.8	87.2	84.5	81.3	75.4
8000	83.5	84.5	82.8	81.8	79.3	75.3	72.0	72.6	74.3	77.3	79.4	82.1	85.5	82.3	79.4	73.8
10000	83.3	84.7	84.3	83.4	80.6	77.1	72.1	71.3	70.5	72.5	74.2	75.6	78.6	75.3	73.8	68.5

TABLE XVI. - Continued.

(c) 80 Percent of design speed.

FREQUENCY	ANGLE, DEG															
	10	20	30	40	50	60	70	80	90	100	110	120	130	140	150	160
	1/3-OCTAVE BAND SOUND PRESSURE LEVELS (SPL) ON 45.7 METER RADIUS															
50	83.4	74.2	81.2	79.7	82.1	80.1	77.2	78.9	75.7	77.7	78.6	78.0	78.7	80.6	82.1	82.6
63	71.5	73.3	72.8	72.6	72.8	73.1	73.1	73.0	73.5	74.8	76.1	77.7	78.8	80.3	82.6	83.5
80	73.9	74.7	72.7	71.1	71.2	71.4	71.9	72.2	73.6	75.9	76.7	78.7	80.7	82.9	84.7	85.6
100	80.4	79.4	79.9	78.8	76.3	78.8	79.1	77.1	77.8	79.4	81.6	82.2	84.1	84.4	86.4	85.7
125	80.9	81.9	80.6	80.1	78.6	79.1	79.6	79.8	80.9	82.4	83.6	84.5	84.3	85.9	86.6	85.0
160	80.6	81.1	80.8	80.8	79.9	80.8	80.8	81.6	82.8	83.6	84.3	84.7	84.1	84.8	85.3	84.0
200	80.1	80.0	79.3	78.1	78.1	78.5	78.6	79.5	80.0	80.8	81.6	82.2	83.3	83.8	84.8	83.5
250	78.5	79.3	78.3	77.8	79.0	79.3	80.0	81.5	82.8	85.0	85.7	86.6	86.5	86.5	86.0	84.2
315	78.7	79.7	79.7	81.0	81.7	82.0	82.8	83.3	84.5	86.3	87.2	87.9	87.7	87.0	86.5	84.6
400	78.8	78.8	78.8	79.4	80.1	81.6	82.1	82.9	84.3	86.4	87.6	88.5	88.4	87.6	86.1	84.1
500	78.2	78.6	78.6	78.6	80.4	81.2	81.7	82.9	83.9	85.4	85.7	87.0	88.4	86.9	85.4	82.9
630	77.3	78.2	77.7	78.0	78.7	79.5	80.5	81.7	82.8	84.2	85.0	86.6	87.8	86.7	84.3	82.4
800	76.5	76.4	76.2	76.4	77.2	77.9	79.2	80.0	80.9	82.4	84.0	85.1	86.5	85.4	83.0	81.1
1000	75.7	74.8	75.0	75.2	76.0	76.3	77.5	78.2	78.8	81.2	82.7	84.2	84.7	83.7	81.5	79.9
1250	75.4	73.9	74.1	74.1	74.6	75.8	76.9	77.9	78.8	80.1	81.3	82.9	83.3	81.8	79.9	77.5
1600	75.6	74.3	74.0	73.8	74.5	75.1	76.3	76.8	77.6	78.8	80.3	80.9	82.1	80.6	79.1	76.7
2000	76.5	75.1	74.6	74.1	74.1	74.8	75.4	76.1	77.1	78.6	79.2	80.0	81.4	79.6	77.9	75.1
2500	83.0	81.5	81.8	80.7	76.5	76.3	75.2	75.7	76.8	78.0	79.0	80.8	82.7	80.5	78.0	74.9
3150	79.9	78.4	76.1	75.2	74.3	74.6	74.4	75.4	75.7	77.1	77.6	79.5	80.9	78.4	76.7	73.2
4000	82.6	81.7	80.1	78.4	76.1	75.1	74.9	75.7	75.7	77.0	78.0	78.8	79.9	77.8	75.8	72.6
5000	85.8	85.5	87.0	84.8	80.8	77.3	76.4	75.8	76.3	76.8	77.8	78.4	81.0	77.3	75.8	72.4
6300	86.1	85.8	83.6	82.3	80.2	78.3	74.7	75.3	76.3	79.0	80.0	82.8	83.3	80.5	77.7	73.7
8000	87.1	87.8	86.0	85.0	83.6	80.0	76.1	76.6	77.9	80.3	81.8	83.9	85.9	81.1	79.6	74.4
10000	85.7	86.7	86.0	85.2	82.5	79.7	75.5	75.1	74.9	76.7	77.7	79.2	80.7	77.7	76.2	71.4

TABLE XVI. - Concluded.

(d) 90 Percent of design speed.

FREQUENCY	ANGLE, DEG															
	10	20	30	40	50	60	70	80	90	100	110	120	130	140	150	160
1/3-OCTAVE BAND SOUND PRESSURE LEVELS (SPL) ON 45.7 METER RADIUS																
50	80.5	76.3	77.0	81.1	77.8	84.6	77.5	78.3	78.8	80.1	81.5	81.4	82.3	81.8	84.5	85.7
63	74.7	75.7	76.3	75.5	75.7	76.8	76.3	76.0	76.3	77.8	79.2	79.7	82.7	83.3	86.8	86.7
80	76.5	77.4	74.7	74.4	74.2	74.4	74.9	75.2	76.7	79.0	80.4	81.8	83.2	86.2	88.4	89.4
100	84.6	84.1	82.3	80.8	79.6	79.8	81.1	80.5	83.0	84.8	85.1	85.7	87.3	88.8	90.1	90.0
125	84.8	85.1	84.3	83.5	83.0	82.8	83.1	83.6	84.8	86.3	86.8	87.7	88.5	90.1	90.6	90.4
160	83.3	84.2	84.3	84.3	84.0	84.8	85.2	86.2	87.0	87.7	88.5	89.1	88.7	89.5	89.5	89.0
200	83.9	84.7	83.7	82.9	82.9	83.0	83.5	83.7	84.0	85.2	86.0	87.3	87.9	88.4	88.7	88.4
250	83.1	83.6	82.9	83.3	83.9	84.4	84.8	86.4	87.8	89.6	90.6	91.4	91.3	90.8	91.6	90.3
315	83.1	84.4	85.6	86.2	87.2	87.9	88.4	89.1	89.7	91.2	91.7	92.5	92.1	92.1	91.4	90.8
400	83.1	83.6	83.8	84.9	85.9	87.3	87.9	88.3	90.1	92.1	93.8	95.0	94.4	93.3	92.1	91.2
500	82.8	83.8	84.0	84.0	85.3	86.5	87.5	88.0	89.1	90.1	91.5	92.7	93.8	92.8	91.3	89.8
630	81.9	82.9	82.9	83.1	84.6	85.4	86.6	87.2	88.2	89.1	90.6	91.8	92.9	92.4	90.7	89.5
800	80.2	81.1	81.2	81.7	82.7	83.4	84.9	86.2	87.4	88.6	89.9	91.2	92.1	92.1	89.1	87.5
1000	79.6	79.4	79.9	80.2	80.7	81.6	82.7	83.7	84.6	86.6	88.2	89.5	90.7	90.4	88.4	86.8
1250	79.0	78.4	78.4	79.0	79.7	80.4	81.4	83.0	83.9	85.5	86.9	88.0	89.0	88.7	86.9	84.4
1600	78.5	78.0	78.0	78.1	79.1	79.6	81.0	81.5	82.5	84.1	85.5	86.2	87.5	87.0	85.8	83.0
2000	78.9	78.7	78.2	78.6	79.0	79.5	80.2	80.7	82.0	83.5	84.8	85.4	86.8	86.2	84.0	80.9
2500	85.2	83.9	81.7	81.5	80.0	79.7	79.9	80.0	81.2	82.5	83.5	85.1	86.4	84.2	83.4	79.4
3150	87.8	85.6	83.8	83.3	81.4	80.3	79.9	79.9	80.8	82.8	83.4	85.2	86.6	84.8	83.4	79.5
4000	85.3	84.5	83.2	81.8	79.9	79.5	79.2	80.3	80.8	81.9	83.3	84.5	85.3	84.4	81.9	78.5
5000	87.3	86.8	87.1	86.3	81.1	81.1	80.1	79.4	80.3	81.4	82.6	83.5	84.6	82.4	80.6	76.5
6300	88.6	88.6	88.1	87.6	84.0	83.6	79.3	79.3	79.9	82.1	83.3	85.2	86.4	85.4	81.6	77.9
8000	88.7	89.2	88.9	88.0	85.4	83.4	79.0	79.4	80.9	82.7	83.7	85.0	86.7	84.0	82.5	77.0
10000	86.8	87.5	87.8	86.9	84.4	82.8	78.3	78.1	78.7	79.8	81.0	82.0	82.8	81.8	79.8	74.6

TABLE XVII. - NOISE OF QF-1A CONFIGURATION 89 (ACTIVE SHORT STATOR,
ACTIVE INLET WITH RINGS, ACTIVE EXHAUST DUCT)

[Data adjusted to standard day of 25⁰ C and 70 percent relative humidity;
SPL re 2×10⁻⁵ N/m².]

(a) 60 Percent of design speed.

FREQUENCY	ANGLE, DEG															
	10	20	30	40	50	60	70	80	90	100	110	120	130	140	150	160
	1/3-OCTAVE BAND SOUND PRESSURE LEVELS (SPL) ON 45.7 METER RADIUS															
50	71.8	67.6	68.0	68.3	68.0	67.8	67.8	68.3	69.6	69.8	70.1	71.1	70.8	71.0	73.3	73.9
63	69.3	67.9	67.1	65.9	67.4	67.9	67.8	66.9	67.9	67.4	68.9	71.8	71.6	71.4	73.1	74.3
80	71.4	72.1	69.4	67.6	68.4	67.4	66.4	66.8	67.4	68.3	69.9	71.4	73.1	73.9	75.9	75.8
100	78.1	77.1	75.8	75.0	74.5	73.5	72.3	71.6	72.1	72.6	74.1	74.6	76.8	77.0	78.0	76.9
125	79.2	80.6	79.2	77.9	76.4	75.4	74.7	74.7	75.2	75.4	77.6	77.7	77.6	77.9	78.1	77.8
160	78.4	78.6	77.3	75.9	73.9	74.3	74.6	74.9	74.9	75.6	77.4	77.7	76.8	76.8	76.1	75.8
200	79.3	79.6	77.1	74.1	72.9	72.6	71.9	72.9	73.3	73.9	75.6	75.9	76.8	76.1	76.6	75.8
250	78.9	79.7	77.7	75.4	75.4	75.4	74.6	76.7	78.2	80.1	80.9	82.0	80.9	79.4	76.9	75.3
315	77.9	77.7	76.4	75.9	75.9	75.5	75.9	77.2	78.5	79.7	80.9	81.5	79.9	78.0	76.9	76.3
400	75.6	74.8	74.8	73.8	73.4	73.9	74.4	76.3	77.9	80.1	81.4	82.9	81.6	79.4	76.8	74.8
500	74.7	74.1	72.9	70.9	70.9	71.4	72.4	74.1	76.4	78.1	79.9	80.7	79.6	78.6	75.9	73.8
630	72.0	71.5	70.7	69.2	68.9	69.2	70.2	71.5	73.7	75.4	77.0	78.6	77.7	77.5	74.2	72.8
800	69.9	69.4	69.0	68.5	68.4	68.9	69.7	70.4	70.9	72.4	73.9	76.6	76.5	77.2	73.0	70.8
1000	69.2	68.2	67.7	67.4	67.2	68.1	68.4	68.6	69.9	70.4	71.7	73.3	73.9	74.2	71.2	69.6
1250	69.2	67.8	67.3	66.6	66.3	67.0	67.3	68.3	68.3	69.1	70.1	71.7	72.3	71.8	70.0	67.7
1600	76.4	76.4	73.2	70.7	69.7	67.9	66.6	67.7	67.9	69.2	70.2	71.0	71.6	70.9	69.4	67.6
2000	81.6	82.6	79.7	76.4	72.2	70.9	67.6	69.1	69.1	70.7	71.2	71.0	73.1	72.2	70.2	68.1
2500	72.6	71.6	69.2	67.1	65.1	64.6	64.9	66.1	67.1	67.6	68.2	71.0	70.9	69.7	67.1	65.0
3150	76.6	76.6	73.6	71.6	68.6	66.1	66.2	66.9	67.4	68.0	69.1	72.2	73.1	72.2	68.7	65.5
4000	80.4	82.6	79.9	77.2	73.9	70.2	67.7	69.1	68.9	69.9	72.2	73.2	76.7	75.2	72.1	68.8
5000	80.6	80.0	79.2	77.7	72.9	68.4	66.7	69.1	70.7	73.1	73.6	78.4	78.2	75.7	71.2	68.3
6300	81.3	81.0	80.1	79.0	75.4	71.5	68.4	69.1	71.4	73.9	75.1	79.4	79.3	78.6	73.1	69.4
8000	81.2	82.2	80.0	79.7	77.4	73.2	68.0	68.5	70.7	73.0	75.7	79.7	78.8	76.9	73.7	69.3
10000	79.3	80.6	79.3	78.8	76.8	73.2	67.2	67.2	67.8	69.3	71.0	74.3	73.3	71.1	68.4	64.3

TABLE XVII. - Continued.

(b) 70 Percent of design speed.

FREQUENCY	ANGLE, DEG															
	10	20	30	40	50	60	70	80	90	100	110	120	130	140	150	160
	1/3-OCTAVE BAND SOUND PRESSURE LEVELS (SPL) ON 45.7 METER RADIUS															
50	73.5	70.8	70.7	72.0	72.0	70.8	71.3	73.5	73.0	73.0	73.2	73.7	74.7	76.2	77.5	78.9
63	70.9	71.1	70.6	70.4	71.3	70.3	70.4	70.8	70.6	70.8	72.3	74.9	75.6	76.1	77.9	79.3
80	76.0	76.2	73.8	72.0	70.8	71.2	72.0	71.8	71.7	72.5	74.3	76.1	78.3	79.2	79.8	80.9
100	81.5	81.2	79.7	78.7	75.8	76.2	75.2	76.0	76.8	77.0	78.5	79.7	81.2	81.8	83.3	82.9
125	83.9	83.9	83.5	82.2	80.5	79.7	79.7	79.0	80.7	80.9	81.7	82.1	83.4	83.4	84.4	82.9
160	81.5	81.8	81.3	79.6	79.0	79.5	80.1	79.6	81.1	80.8	82.8	82.2	82.8	82.3	82.1	81.8
200	81.3	81.5	79.5	77.6	77.0	77.6	77.6	78.6	78.3	79.3	80.3	80.9	82.1	82.1	81.5	81.4
250	79.2	80.4	78.9	78.7	79.4	78.9	80.2	81.9	83.4	84.7	86.2	86.5	86.7	84.4	82.4	80.3
315	77.7	78.4	78.9	80.1	80.4	80.4	81.2	83.2	84.7	86.1	86.9	86.5	85.1	83.2	82.1	81.3
400	77.0	77.0	77.1	77.6	78.0	79.1	80.5	81.8	83.8	85.5	87.0	87.7	87.1	84.3	82.0	79.8
500	75.9	75.9	75.4	74.8	76.4	77.4	78.4	80.3	81.6	83.6	85.4	86.2	85.6	84.3	81.4	79.3
630	74.3	74.3	73.5	73.3	73.8	74.5	76.0	77.7	79.7	82.0	83.7	84.9	84.2	83.2	80.3	78.2
800	73.2	72.3	71.8	72.3	72.3	73.3	74.0	75.0	76.3	78.2	80.3	82.6	82.8	82.5	79.0	76.7
1000	72.3	70.9	70.9	70.9	71.3	71.8	72.3	73.3	74.1	75.8	77.4	79.5	80.3	80.3	76.8	75.2
1250	72.5	71.0	70.5	70.6	71.6	71.6	71.8	73.0	73.5	74.3	75.8	77.7	78.3	77.8	75.6	74.2
1600	73.3	72.8	71.8	71.1	70.8	71.1	71.1	72.4	72.9	73.6	75.1	76.2	77.1	76.3	74.4	72.2
2000	80.9	81.4	78.9	77.1	73.9	74.4	72.2	73.0	73.2	74.5	76.9	78.7	78.7	76.7	74.9	73.1
2500	77.1	77.3	74.5	73.1	71.3	71.0	71.0	71.6	72.5	73.6	74.8	78.2	78.0	75.8	73.6	71.0
3150	78.2	77.0	73.9	72.5	71.2	70.7	71.2	71.4	72.9	73.5	74.7	77.6	78.5	76.7	73.4	70.4
4000	83.1	83.6	81.5	80.6	77.3	73.9	72.1	73.4	72.8	73.8	77.1	78.9	80.1	78.4	75.4	72.4
5000	82.6	82.3	80.9	80.1	76.1	72.6	71.9	74.6	76.3	77.6	78.4	81.9	82.4	79.1	75.4	72.9
6300	84.6	84.3	83.1	83.6	80.5	78.0	74.3	75.1	77.4	79.4	80.6	81.2	85.1	82.3	78.4	73.9
8000	83.9	84.4	82.6	82.0	80.2	76.9	72.9	73.7	76.2	78.5	80.9	81.2	83.3	80.6	77.5	73.8
10000	83.5	84.4	82.8	82.6	81.3	78.1	72.6	72.5	72.8	73.8	76.0	75.1	78.3	75.6	73.0	69.8

TABLE XVII. - Continued.

(c) 80 Percent of design speed.

FREQUENCY	ANGLE, DEG															
	10	20	30	40	50	60	70	80	90	100	110	120	130	140	150	160
	1/3-OCTAVE BAND SOUND PRESSURE LEVELS (SPL) ON 45.7 METER RADIUS															
50	78.1	71.9	74.9	79.6	80.1	79.1	78.8	76.3	75.4	77.8	78.6	78.7	79.8	80.1	81.9	82.3
63	72.5	73.5	73.0	72.5	76.5	72.6	73.5	73.6	73.6	74.5	76.1	77.9	79.5	79.5	81.5	81.8
80	76.5	77.0	74.8	73.1	73.1	74.3	74.1	73.6	75.3	76.5	78.0	79.1	81.5	83.0	84.8	84.8
100	84.0	81.3	79.5	79.3	78.8	82.8	80.1	79.3	82.0	82.3	82.6	84.2	86.1	86.6	88.3	88.8
125	82.1	82.1	81.8	80.8	79.8	82.0	81.6	81.8	83.3	84.5	86.0	86.4	87.0	87.6	88.3	87.3
160	80.0	80.9	81.7	82.0	80.0	83.5	83.5	84.7	85.4	86.2	86.4	87.4	86.7	86.0	85.2	85.9
200	81.7	82.2	82.0	80.3	80.7	81.5	81.2	82.7	82.3	83.0	83.7	84.8	85.2	85.3	85.2	85.4
250	79.8	80.9	80.4	81.4	82.1	82.6	83.4	84.8	86.6	88.3	89.6	90.0	90.1	88.1	87.1	84.3
315	79.2	80.7	81.6	82.7	83.9	84.7	85.2	87.1	88.6	89.7	90.6	90.3	88.7	87.4	86.6	86.3
400	79.1	79.6	80.3	81.3	82.1	83.5	84.1	85.6	87.8	89.1	90.3	91.2	90.5	88.1	86.5	86.9
500	78.6	79.3	78.8	78.8	80.8	81.8	83.1	84.9	86.6	87.9	89.3	90.3	90.3	88.1	85.9	83.8
630	77.2	77.7	77.7	77.7	78.6	79.4	80.6	82.4	84.6	86.7	88.1	89.6	89.9	87.6	85.1	83.3
800	76.4	76.4	76.0	76.2	77.2	77.5	79.2	80.0	81.2	83.5	86.2	88.4	88.9	86.9	83.4	83.2
1000	75.1	74.3	74.1	74.9	75.4	76.1	76.8	78.1	78.8	80.6	83.3	85.9	86.6	84.6	81.4	80.7
1250	75.2	74.0	73.7	73.9	75.0	75.4	75.9	77.5	77.5	79.0	81.4	83.1	84.5	82.9	80.5	78.3
1600	75.6	75.1	74.1	74.1	74.8	74.9	74.8	76.9	76.9	78.1	80.1	81.7	83.1	81.1	79.4	77.7
2000	78.6	77.3	75.6	75.1	75.1	75.5	75.2	76.6	77.2	78.9	80.7	82.2	82.5	80.1	78.6	77.6
2500	83.3	82.8	80.3	79.6	79.4	76.6	75.6	76.8	77.4	79.1	80.8	84.0	84.8	82.1	78.9	78.0
3150	80.8	79.1	76.8	75.8	75.8	74.8	75.9	76.4	77.4	78.8	80.4	84.0	84.4	81.9	78.3	78.0
4000	83.3	82.8	80.7	79.5	77.3	76.0	75.3	77.5	77.3	78.6	81.6	83.6	84.5	82.1	78.8	75.5
5000	85.9	86.8	86.3	87.9	81.6	78.9	77.3	79.1	79.3	81.1	82.9	86.2	85.8	81.9	78.9	75.4
6300	85.7	85.4	84.4	83.8	83.0	79.9	78.4	79.5	81.7	83.5	85.9	88.2	89.9	85.5	82.3	77.5
8000	86.9	87.4	85.8	86.8	83.9	81.4	77.4	78.6	80.4	83.4	85.7	88.5	88.8	84.2	81.9	76.4
10000	85.5	86.6	85.3	85.4	83.0	80.6	76.2	76.7	77.4	78.8	80.8	83.0	83.1	79.8	77.5	72.8

TABLE XVII. - Concluded.

(d) 90 Percent of design speed.

FREQUENCY	ANGLE, DEG															
	10	20	30	40	50	60	70	80	90	100	110	120	130	140	150	160
1/3-OCTAVE BAND SOUND PRESSURE LEVELS (SPL) ON 45.7 METER RADIUS																
50	78.3	74.7	75.5	80.5	76.7	81.5	78.2	78.0	79.2	80.3	81.2	82.9	82.5	83.0	85.2	86.4
63	74.5	76.4	75.7	75.4	76.0	76.0	75.9	75.9	75.9	78.2	78.9	91.3	82.2	83.4	85.5	86.6
80	78.5	79.2	76.7	75.2	75.4	75.5	75.7	76.2	77.9	79.4	80.7	82.8	84.9	86.5	88.7	89.9
100	85.3	84.5	82.6	83.5	84.0	82.6	83.3	86.3	84.8	85.6	87.8	88.0	89.5	90.6	91.8	91.3
125	84.5	85.8	84.1	83.8	83.6	84.0	83.5	85.1	85.8	87.1	89.0	89.4	90.5	91.1	91.8	91.0
160	83.1	84.3	84.8	84.0	84.1	86.0	86.0	87.1	88.3	89.3	89.3	90.7	89.8	89.6	89.3	89.7
200	85.1	85.7	84.4	83.4	83.9	84.1	84.2	85.4	85.4	86.4	87.1	88.0	88.7	88.7	89.6	89.1
250	83.4	83.9	83.1	83.3	83.6	84.8	85.1	86.3	88.4	90.6	91.9	93.5	92.8	91.9	90.3	89.0
315	82.4	84.0	84.4	85.5	85.7	87.4	87.9	89.5	90.9	91.9	92.5	93.8	91.4	90.9	89.5	89.1
400	82.4	82.6	83.4	83.6	84.1	85.4	86.6	87.8	89.1	90.9	92.8	95.4	93.1	91.1	89.9	88.8
500	82.3	82.8	82.5	82.2	83.5	85.0	86.0	87.7	88.5	90.3	92.0	94.8	93.0	90.8	89.5	87.9
630	81.4	82.0	81.2	81.2	81.7	83.2	84.2	85.5	87.5	89.7	90.9	95.1	93.4	90.9	88.9	87.2
800	80.2	80.2	80.1	79.9	80.7	81.6	83.2	83.7	85.2	87.2	89.7	95.1	93.6	90.9	87.7	86.4
1000	78.9	79.0	79.2	79.2	79.7	80.9	81.4	82.2	83.0	85.4	87.9	93.5	91.4	89.9	86.4	84.9
1250	78.3	77.8	77.7	78.0	78.7	79.5	80.3	81.8	82.2	83.8	86.2	91.3	89.8	87.7	85.7	83.6
1600	78.3	78.1	77.4	77.9	78.4	79.6	79.6	81.1	81.4	83.1	84.9	89.2	87.9	86.4	84.8	82.5
2000	79.6	78.7	78.2	78.0	78.5	79.3	79.3	80.5	81.6	83.0	85.1	89.5	87.6	85.3	83.6	81.5
2500	86.8	83.3	81.5	81.0	80.6	79.6	80.3	80.3	81.5	83.3	84.8	90.7	88.0	85.0	83.1	80.9
3150	86.9	84.1	81.7	81.1	80.6	80.1	80.9	80.6	82.1	83.7	85.4	91.0	89.4	86.4	83.2	81.0
4000	85.9	85.6	83.0	82.3	80.8	80.3	79.7	81.4	81.6	83.1	86.3	90.2	88.5	86.0	83.4	80.8
5000	88.3	88.0	87.8	86.7	82.8	81.2	80.7	82.2	83.3	85.5	86.3	91.8	88.5	84.5	82.2	79.7
6300	88.0	87.9	87.5	87.2	83.8	83.6	81.9	82.9	85.0	87.0	88.8	93.2	91.8	87.6	85.2	80.8
8000	89.4	89.6	87.6	87.6	85.7	83.2	80.7	81.9	84.0	86.9	89.5	93.9	91.9	87.4	85.0	82.0
10000	86.9	88.3	86.5	86.7	84.3	82.6	79.4	79.9	81.4	83.0	84.8	88.2	87.0	84.3	81.7	77.7

TABLE XVIII. - NOISE OF QF-1A CONFIGURATION 90 (ACTIVE SHORT STATOR,
ACTIVE INLET WITHOUT RINGS, ACTIVE EXHAUST DUCT)

[Data adjusted to standard day of 25° C and 70 percent relative humidity;
SPL re 2×10^{-5} N/m².]

(a) 60 Percent of design speed.

FREQUENCY	ANGLE, DEG															
	10	20	30	40	50	60	70	80	90	100	110	120	130	140	150	160
1/3-OCTAVE BAND SOUND PRESSURE LEVELS (SPL) ON 45.7 METER RADIUS																
50	71.0	68.3	68.6	68.0	67.3	66.5	67.1	68.3	69.5	69.6	70.1	70.1	71.3	71.5	72.0	74.5
63	67.8	68.1	67.0	65.5	67.1	67.1	66.6	66.0	66.5	67.1	68.5	68.9	71.1	71.6	72.5	73.5
80	71.1	72.0	69.3	66.6	67.3	67.5	66.1	65.8	67.0	67.5	70.0	70.7	72.5	74.0	75.0	76.0
100	77.8	76.6	76.1	73.6	72.8	73.0	71.3	71.0	72.3	72.0	73.0	74.6	76.5	77.1	77.6	77.5
125	80.3	81.3	80.0	77.6	77.0	75.6	74.8	74.8	74.5	75.6	76.5	77.1	78.5	77.5	78.8	77.8
160	78.8	79.0	78.0	75.5	75.0	74.5	75.0	75.3	75.3	75.3	76.7	77.3	76.7	77.0	76.5	75.9
200	80.0	80.5	77.8	74.3	73.1	73.0	72.5	73.5	73.3	74.3	75.8	75.9	76.6	76.8	76.0	75.7
250	79.7	80.4	78.1	76.1	76.2	75.2	74.9	76.4	77.9	79.7	80.7	81.3	81.1	79.6	76.9	74.4
315	79.4	78.9	76.7	76.2	76.5	75.9	76.5	77.2	78.0	79.7	81.2	81.6	79.9	78.4	76.7	76.3
400	76.3	76.0	76.3	74.6	73.8	73.6	74.1	76.0	77.5	79.8	81.1	82.7	81.8	79.1	76.1	75.5
500	75.4	76.1	74.8	72.1	71.6	71.9	72.6	74.6	75.9	78.4	80.1	80.2	80.3	78.6	75.4	73.2
630	73.5	74.5	72.3	71.1	69.5	70.0	70.5	71.8	73.6	75.8	77.3	77.7	78.1	77.8	73.6	72.0
800	73.2	72.6	72.1	70.2	69.4	69.1	69.7	70.6	71.2	72.2	73.9	75.3	76.7	77.1	72.7	76.6
1000	74.8	75.7	72.8	69.8	69.7	69.0	69.0	69.2	69.5	70.7	71.5	72.9	74.0	74.7	71.2	70.4
1250	76.4	76.9	73.7	70.6	69.1	67.9	67.4	68.6	68.1	69.1	70.2	70.7	72.4	72.1	69.9	68.3
1600	81.8	83.3	80.5	75.5	72.3	70.0	68.6	68.6	68.3	69.1	70.1	70.4	71.8	71.8	69.6	68.4
2000	88.6	90.3	88.3	82.3	78.9	75.8	73.3	72.1	71.4	72.1	72.6	73.0	74.3	73.8	72.3	72.0
2500	79.3	80.0	77.0	72.6	69.8	67.6	66.7	66.8	66.7	67.7	68.2	69.9	70.7	70.2	67.7	65.7
3150	81.0	81.6	79.1	76.3	73.3	69.3	67.6	67.0	67.3	68.1	69.0	70.1	72.5	71.3	68.5	66.9
4000	84.4	86.4	84.6	82.5	78.8	74.1	70.9	69.9	69.1	70.0	71.8	72.1	75.5	75.1	71.8	68.7
5000	82.5	83.3	83.0	80.8	76.3	72.7	69.5	69.3	69.8	72.5	72.3	73.3	76.5	75.3	70.0	67.2
6300	82.6	82.9	82.4	81.6	79.6	76.7	71.4	69.7	70.6	73.2	74.5	75.6	78.4	75.9	72.3	68.7
8000	81.8	82.4	80.8	80.6	78.3	76.1	69.9	68.4	70.1	72.4	75.1	75.6	77.9	77.3	72.4	67.7
10000	79.4	80.2	79.7	79.7	77.6	75.9	69.1	67.1	67.0	68.5	70.9	70.4	73.0	71.5	68.0	63.7

TABLE XVIII. - Continued.

(b) 70 Percent of design speed.

FREQUENCY	ANGLE, DEG															
	10	20	30	40	50	60	70	80	90	100	110	120	130	140	150	160
1/3-OCTAVE BAND SOUND PRESSURE LEVELS (SPL) ON 45.7 METER RADIUS																
50	73.2	71.9	71.5	71.2	70.7	70.4	72.2	72.0	73.0	73.4	73.4	73.3	74.5	75.9	76.9	78.8
63	70.5	71.0	70.7	70.2	70.8	70.2	70.2	69.0	70.2	71.0	72.3	73.6	74.5	76.0	77.0	78.4
80	75.0	75.8	72.7	70.2	70.5	69.3	71.0	70.2	71.7	72.3	73.8	75.4	77.2	79.0	79.7	81.2
100	81.7	80.7	79.7	78.3	75.7	76.2	75.7	75.8	77.0	77.0	78.2	79.3	81.3	81.5	82.2	83.1
125	84.2	84.6	83.4	81.6	80.6	79.2	79.4	78.9	79.6	80.6	82.1	82.5	82.9	83.1	83.6	82.8
160	81.9	82.9	81.2	79.4	79.5	79.7	78.7	79.9	80.7	81.4	82.2	82.6	82.4	82.0	81.4	81.6
200	81.9	82.1	79.9	77.9	78.2	77.6	77.1	78.7	78.7	79.2	80.6	81.0	82.4	81.7	81.1	81.1
250	79.9	80.9	78.9	78.8	78.8	78.8	79.8	81.3	82.8	84.4	86.4	86.7	86.3	84.9	81.9	80.0
315	79.0	78.8	79.6	79.5	80.5	80.5	81.3	83.5	85.0	86.0	86.8	86.7	85.5	83.6	81.8	80.7
400	77.0	77.8	78.0	77.3	77.5	78.7	79.8	81.8	83.5	85.5	86.8	87.4	87.3	84.3	81.3	80.5
500	77.4	78.0	76.7	75.2	76.5	77.5	78.0	80.0	81.9	83.7	85.5	86.3	86.2	84.5	81.2	79.7
630	76.4	76.8	75.8	74.3	74.3	75.1	75.8	77.6	79.4	82.1	83.6	84.5	84.6	83.6	80.1	78.0
800	75.9	75.6	74.9	73.3	72.8	73.1	74.1	75.4	75.9	78.1	80.4	82.2	83.1	82.4	78.4	77.7
1000	76.5	77.0	75.4	73.2	72.4	72.0	72.7	73.4	74.0	75.7	77.9	79.5	80.5	80.0	76.4	75.6
1250	78.4	78.8	76.1	73.6	72.8	71.9	72.3	73.3	73.4	74.4	75.8	77.0	78.4	77.6	75.1	73.5
1600	80.1	80.2	77.6	74.7	72.6	71.6	71.2	72.6	72.7	73.7	75.4	75.7	77.4	76.7	74.1	72.3
2000	88.4	90.2	87.2	82.7	79.4	77.2	74.9	74.7	74.2	74.7	77.0	77.6	78.3	77.0	75.0	73.9
2500	85.2	86.4	83.7	79.4	76.4	73.7	72.7	72.4	72.7	73.5	74.7	76.6	77.9	75.9	73.4	71.6
3150	82.5	83.2	80.2	77.4	75.0	72.2	71.4	71.4	72.2	73.2	74.2	75.8	78.7	76.2	72.7	71.1
4000	85.6	87.6	86.5	84.3	81.1	77.3	73.4	73.4	72.4	73.3	76.6	76.9	79.6	78.4	74.6	71.4
5000	84.5	86.2	85.7	83.7	79.9	76.5	73.2	74.5	75.0	76.4	77.0	78.6	81.0	78.3	73.5	71.4
6300	85.8	86.7	86.5	85.8	84.9	82.3	77.0	75.2	77.0	79.0	80.3	81.2	84.7	79.9	76.9	74.0
8000	84.5	85.3	83.6	83.8	81.8	80.3	74.5	73.3	75.5	78.1	81.0	81.0	83.4	81.1	76.6	72.4
10000	83.1	84.4	83.7	83.8	81.7	80.5	74.2	72.3	72.1	73.7	75.9	75.4	78.2	75.2	72.2	68.9

TABLE XVIII. - Continued.

(c) 80 Percent of design speed.

FREQUENCY	ANGLE, DEG															
	10	20	30	40	50	60	70	80	90	100	110	120	130	140	150	160
1/3-OCTAVE BAND SOUND PRESSURE LEVELS (SPL) ON 45.7 METER RADIUS																
50	81.7	73.5	77.5	78.0	80.7	76.9	77.9	74.5	77.0	76.9	76.4	78.3	77.9	79.5	81.2	82.1
63	72.4	73.6	72.6	72.2	72.7	72.2	72.2	72.9	73.2	73.6	74.9	76.8	78.4	78.9	81.1	81.9
80	75.9	76.9	73.7	72.2	71.7	72.7	72.9	73.4	74.2	75.7	77.4	78.6	81.0	82.4	83.9	84.9
100	83.0	81.7	79.8	78.3	77.5	81.2	79.0	78.7	81.3	81.8	82.2	83.6	84.8	86.3	87.8	87.9
125	82.7	82.8	81.5	81.2	79.8	80.7	80.8	81.7	83.2	84.5	85.3	85.9	87.3	87.3	88.3	87.0
160	80.8	80.6	81.3	81.3	80.6	83.0	83.3	84.0	85.1	85.5	86.1	87.2	87.1	86.8	86.0	85.9
200	81.7	82.8	81.5	80.5	81.0	81.8	81.7	83.2	82.7	83.2	83.8	84.8	85.2	85.3	84.8	84.9
250	80.6	81.1	80.9	80.8	81.8	81.8	83.3	84.1	86.1	88.1	89.4	89.5	89.6	88.6	86.4	84.3
315	80.8	81.1	82.8	82.8	84.0	84.5	85.6	86.8	88.5	89.8	90.5	90.4	89.1	87.6	85.8	85.7
400	79.9	80.3	80.3	81.3	81.6	82.8	83.6	85.3	86.9	88.8	90.1	90.7	90.3	88.1	85.6	85.5
500	79.6	80.4	79.8	79.4	80.3	81.4	82.3	84.8	86.3	87.9	89.6	90.2	89.8	88.1	85.4	84.2
630	80.2	80.4	80.1	78.6	78.7	79.2	80.6	82.4	84.7	86.7	88.7	90.0	90.1	87.9	84.7	83.1
800	79.9	79.4	78.9	77.6	77.6	77.7	79.1	80.1	81.1	83.6	86.2	88.3	89.1	87.1	83.1	82.1
1000	79.5	79.9	78.4	77.0	75.9	76.2	76.9	77.9	78.9	80.7	83.4	86.1	87.0	85.2	81.7	80.2
1250	80.9	81.0	79.0	77.2	75.4	75.9	76.0	77.0	77.4	78.9	81.4	82.6	84.4	83.2	80.4	78.4
1600	82.3	82.3	80.2	77.7	75.5	75.6	75.5	76.6	77.1	78.1	80.5	80.9	83.3	81.5	79.3	77.2
2000	85.1	84.1	82.2	79.2	76.7	76.4	75.7	76.4	77.1	78.4	80.8	81.5	82.6	80.8	78.5	76.9
2500	89.9	91.8	89.6	86.6	84.1	80.9	78.4	78.1	78.4	79.6	81.3	83.9	84.9	81.8	79.1	78.0
3150	85.5	85.4	83.4	80.6	78.2	76.2	76.1	75.9	77.1	78.6	80.2	82.5	84.7	81.4	78.1	76.6
4000	86.7	87.8	86.2	84.5	80.7	78.2	76.0	76.7	76.7	78.3	81.3	82.1	84.6	82.1	78.7	75.5
5000	88.8	90.3	90.3	90.7	85.7	82.9	79.9	79.2	79.4	80.9	82.7	83.5	85.2	82.2	77.9	75.5
6300	87.9	88.1	87.9	87.7	86.1	83.7	80.3	79.1	80.9	83.0	85.0	86.0	89.0	83.5	81.0	77.7
8000	88.5	89.2	88.0	88.2	87.0	85.7	80.3	79.0	80.3	83.0	85.8	86.5	88.3	85.6	81.5	77.0
10000	86.8	87.7	87.3	87.0	85.0	84.0	78.8	76.8	77.3	79.0	81.3	80.9	83.6	80.2	77.4	73.7

TABLE XVIII. - Concluded.

(d) 90 Percent of design speed.

FREQUENCY	ANGLE, DEG															
	10	20	30	40	50	60	70	80	90	100	110	120	130	140	150	160
	1/3-OCTAVE BAND SOUND PRESSURE LEVELS (SPL) ON 45.7 METER RADIUS															
50	77.8	76.1	78.8	81.3	76.8	81.1	78.1	77.1	77.8	81.6	80.3	81.3	81.8	83.3	85.3	86.7
63	74.6	76.3	77.1	77.1	73.3	76.6	76.6	76.1	76.3	78.3	80.1	80.1	81.6	83.8	85.1	86.7
80	79.3	79.8	77.1	77.3	73.6	76.1	76.3	76.1	77.8	79.1	81.8	82.1	84.3	86.3	88.6	90.2
100	86.1	86.1	84.6	84.6	83.8	85.1	82.3	84.1	85.3	85.6	88.3	88.3	90.3	90.8	92.1	92.4
125	85.6	87.6	86.3	85.8	84.1	84.8	83.8	85.6	87.1	87.8	89.8	90.3	91.1	91.3	91.8	91.5
160	83.6	85.4	85.9	85.9	83.9	86.9	86.6	87.9	88.9	89.6	90.4	90.6	90.1	90.1	89.4	90.2
200	87.3	88.1	86.6	85.1	84.6	84.6	84.6	86.6	86.3	86.8	87.3	88.6	88.8	88.8	89.3	89.7
250	85.0	85.8	85.8	85.5	84.8	85.8	85.5	86.5	88.8	90.3	92.0	92.8	93.5	92.0	90.5	88.9
315	84.0	85.5	85.8	86.5	86.5	87.5	88.5	90.3	91.0	92.8	93.5	93.3	92.3	91.0	90.3	89.9
400	83.6	84.3	85.1	85.6	85.3	85.6	86.6	88.1	89.6	91.6	93.1	93.8	93.8	91.8	90.1	89.2
500	83.5	85.8	84.3	84.0	85.0	85.0	86.8	88.0	89.5	91.0	92.5	93.1	93.5	91.0	90.3	88.7
630	83.4	85.7	83.9	83.7	83.7	83.7	84.4	86.4	87.9	89.9	91.7	93.0	93.9	91.2	89.2	87.8
800	84.7	85.2	84.0	83.7	83.0	82.5	83.7	84.5	85.5	88.0	90.2	92.7	93.7	91.2	88.2	86.9
1000	84.6	85.1	83.6	83.1	82.1	81.1	82.1	82.9	83.4	85.9	88.4	90.9	91.6	89.9	86.9	85.7
1250	85.5	85.7	83.7	82.5	81.5	81.0	81.5	82.2	82.5	84.5	86.7	88.2	90.2	88.0	86.2	84.1
1600	86.1	86.1	83.9	82.4	81.1	80.1	80.1	81.4	81.6	83.1	85.6	86.1	88.4	86.6	85.1	83.0
2000	87.3	87.3	85.5	83.8	82.5	81.0	80.3	81.6	81.9	83.6	85.4	86.3	87.6	85.1	83.6	82.3
2500	91.8	93.3	90.8	90.3	87.8	84.0	82.5	81.8	82.3	83.8	85.5	87.3	88.5	85.5	83.3	81.4
3150	91.4	92.7	90.7	89.2	87.4	83.9	82.9	81.4	82.4	83.7	85.7	87.7	89.7	86.4	83.4	81.9
4000	89.6	91.1	89.1	88.3	85.3	82.6	80.9	81.8	81.3	83.3	86.3	86.7	88.9	86.2	83.7	81.1
5000	91.6	92.8	93.1	93.1	88.1	84.8	82.6	82.6	82.8	85.3	86.3	87.6	88.8	84.8	81.8	80.0
6300	90.8	91.8	91.6	92.8	90.4	87.1	84.1	82.8	84.1	86.9	88.8	88.9	91.3	87.6	84.5	81.8
8000	90.3	91.5	90.5	91.8	89.0	86.0	82.3	82.0	83.3	86.3	89.3	89.9	91.8	87.0	85.0	80.8
10000	88.3	89.8	89.3	90.3	87.8	85.3	81.3	80.8	80.8	82.7	85.0	84.8	87.2	84.7	81.5	77.7

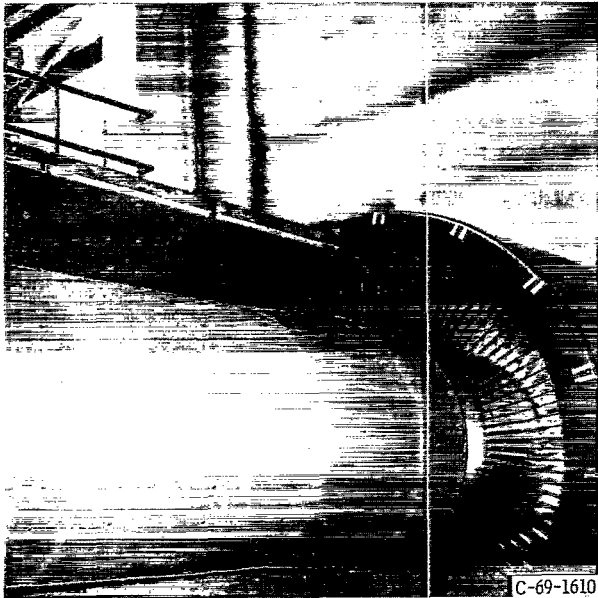

(a) Original QF-2 stator vanes.

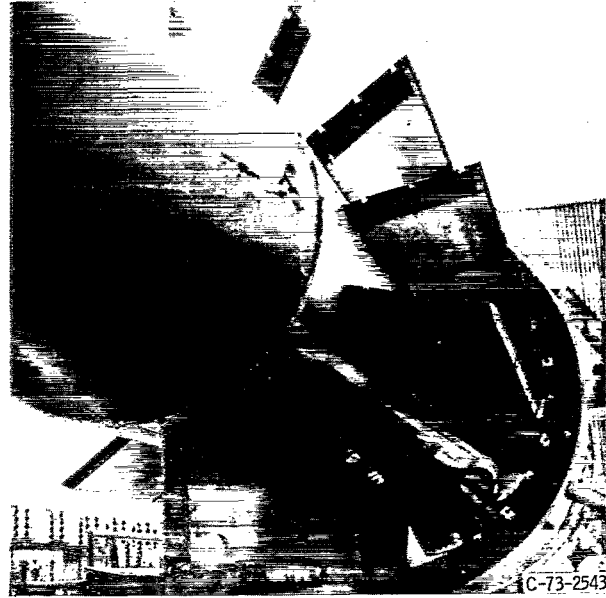

(b) Long-chord stator.

Figure 1. - Fan stator vanes (viewed from downstream).

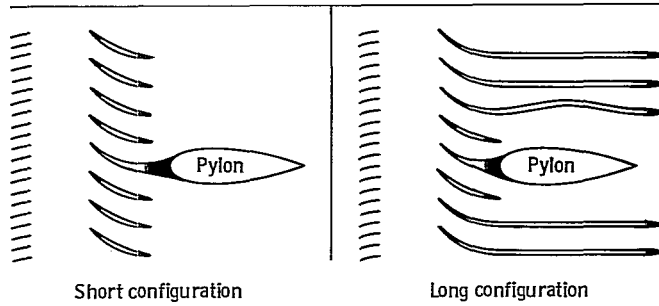
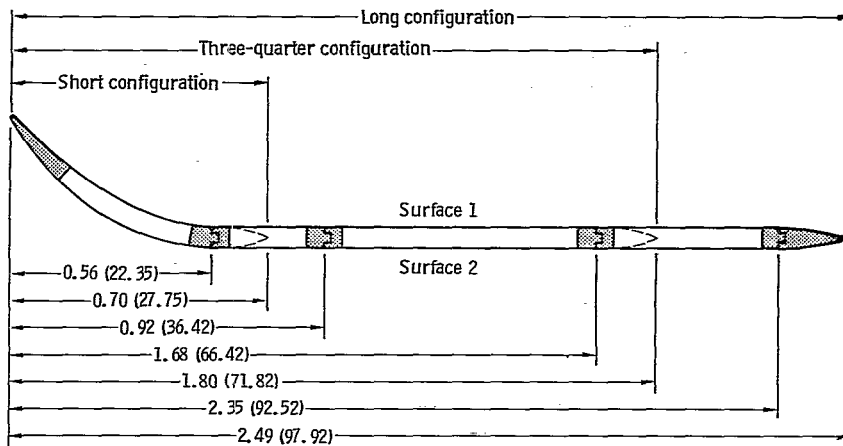

Figure 2. - Developed views of length variations.



(a) Long-chord stator on work table.



Surface	Open area, percent	Perforated-facing-sheet hole diameter		Honeycomb backing thickness		Predicted frequency of maximum noise attenuation, Hz
		mm	in.	cm	in.	
1	5	1.27	0.050	0.81	0.32	3600
2	11	1.14	.045	2.24	.88	2400

(b) Stator length variations. (Dimensions are in meters (in.)).

Figure 3. - Long-chord stator configuration. Suppressor perforated facing sheet: thickness, 0.51 millimeter (0.020 in.); material, aluminum; honeycomb cell size, 0.95-centimeter (3/8-in.) hexagons.

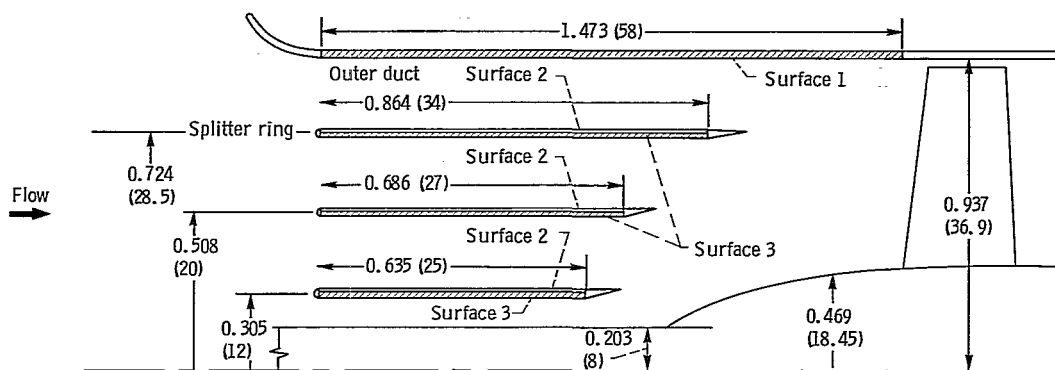
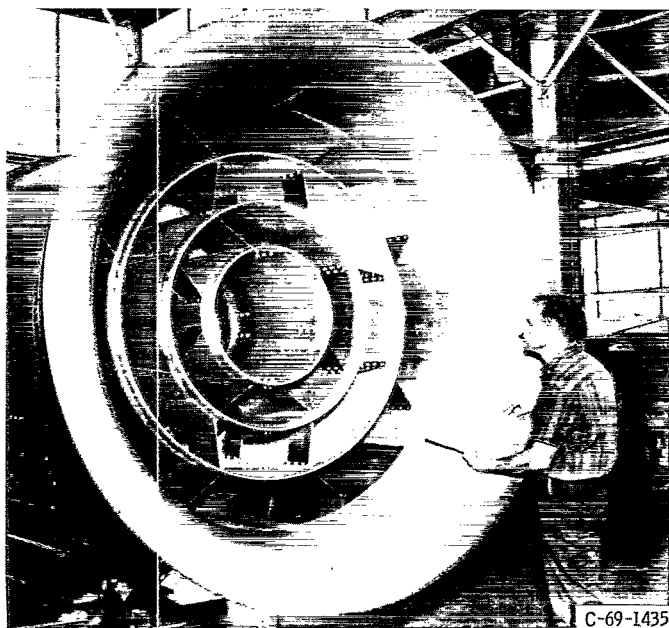

Surface	Honeycomb backing thickness		Predicted frequency of maximum noise attenuation, Hz
	cm	in.	
1	2.24	0.88	1250
2	.51	.20	3150
3	1.73	.68	1600

Figure 4. - Inlet suppressor. Perforated facing sheet: thickness, 0.51 millimeter (0.020 in.); material, aluminum; honeycomb cell size, 0.95-centimeter (3/8-in.) hexagons; hole diameter, 0.81 millimeter (0.032 in.). Open area, 2.5 percent. (Dimensions are in meters (in.).)

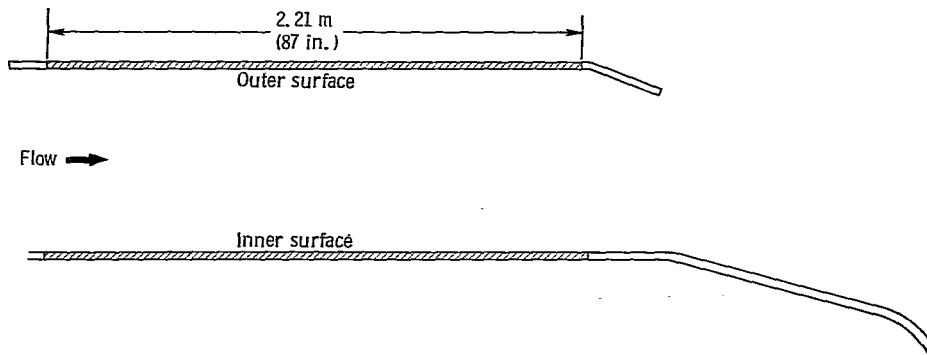
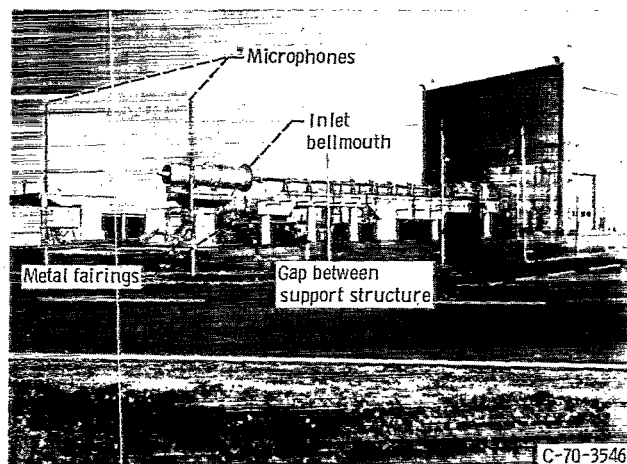
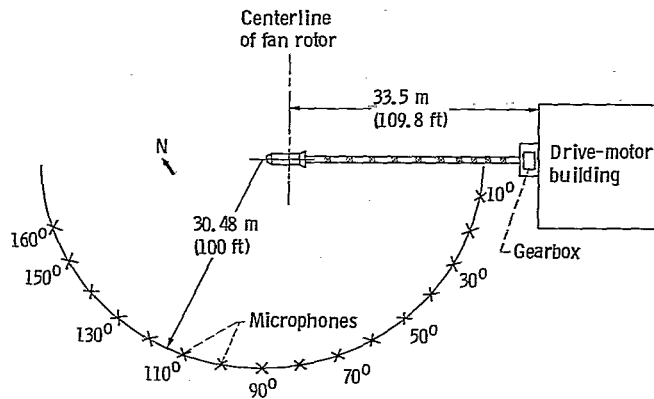

Figure 5. - Exhaust suppressor. Perforated facing sheet: thickness, 0.51 millimeter (0.02 in.); material, aluminum; honeycomb cell size, 0.95-centimeter (3/8-in.) hexagons; hole diameter, 1.27 millimeters (0.050 in.); honeycomb backing depth, 2.24 centimeters (0.88 in.). Open area, 8 percent; predicted frequency of maximum attenuation, 1250 hertz.



(a) test site.



(b) Plan view of test site.

Figure 6. - Full-scale fan test facility.

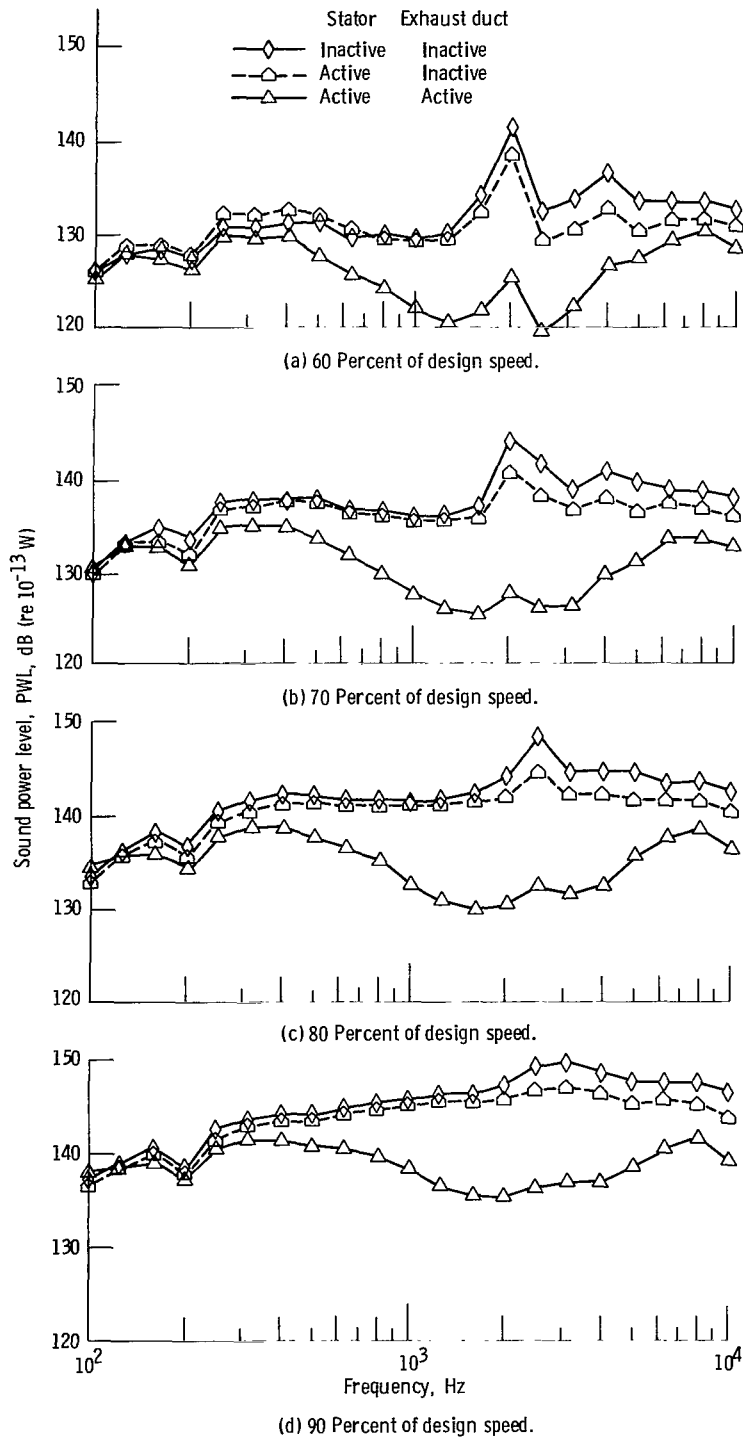

Figure 7. - Total sound power level variation with frequency for short stator configuration with active three-ring inlet.

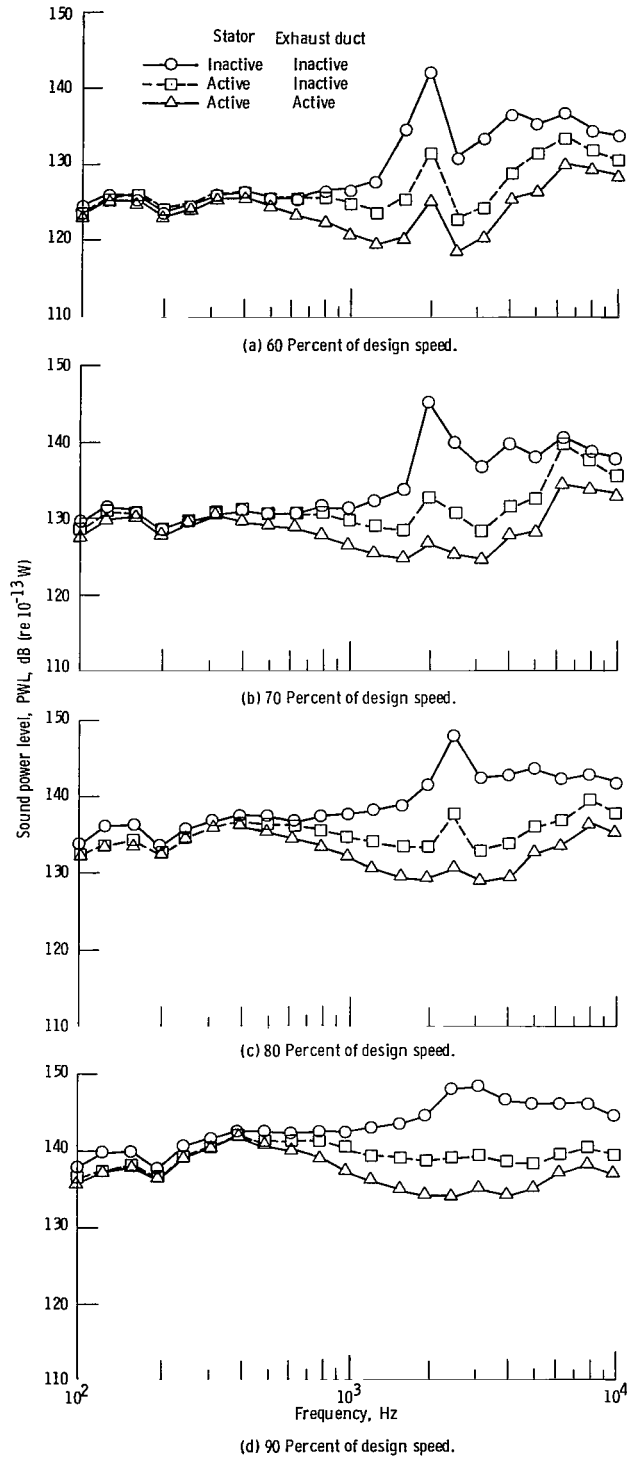

Figure 8. - Total sound power level variation with frequency for long stator configuration with active three-ring inlet.

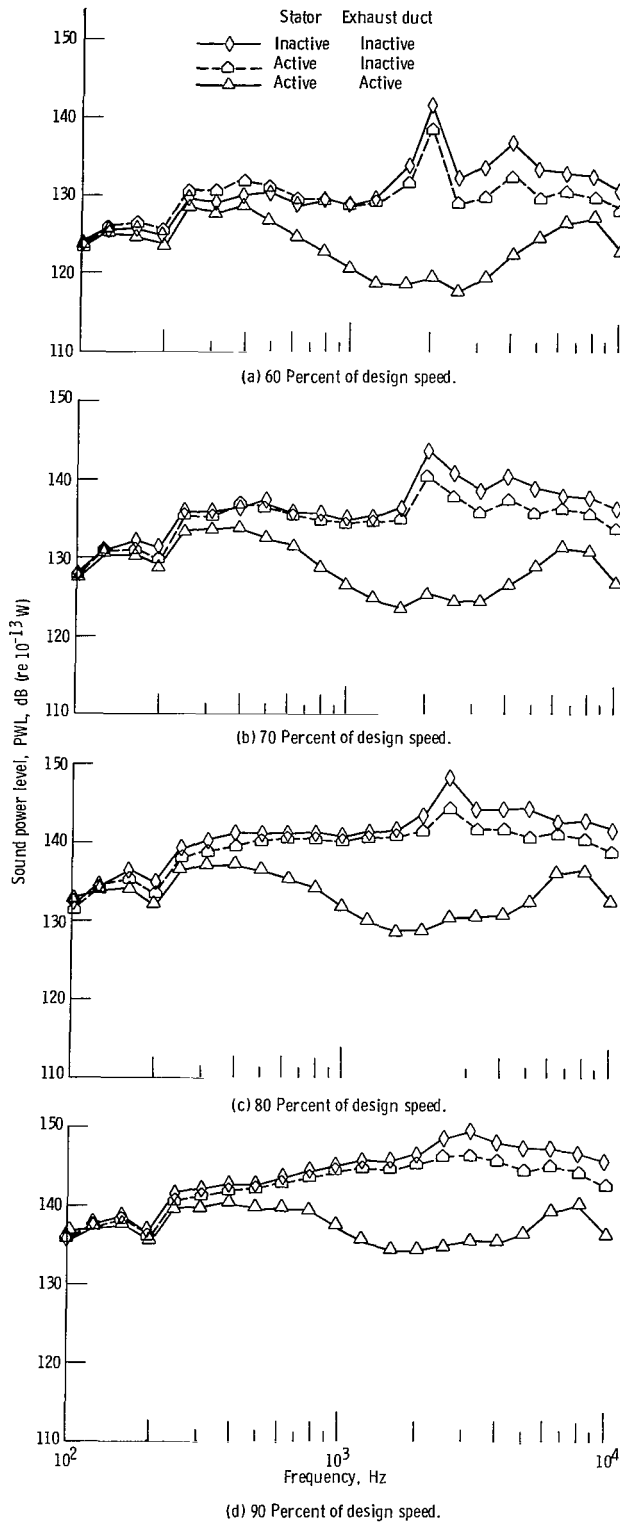

Figure 9. - Rear-hemisphere sound power level variation with frequency for short stator configuration with active three-ring inlet.

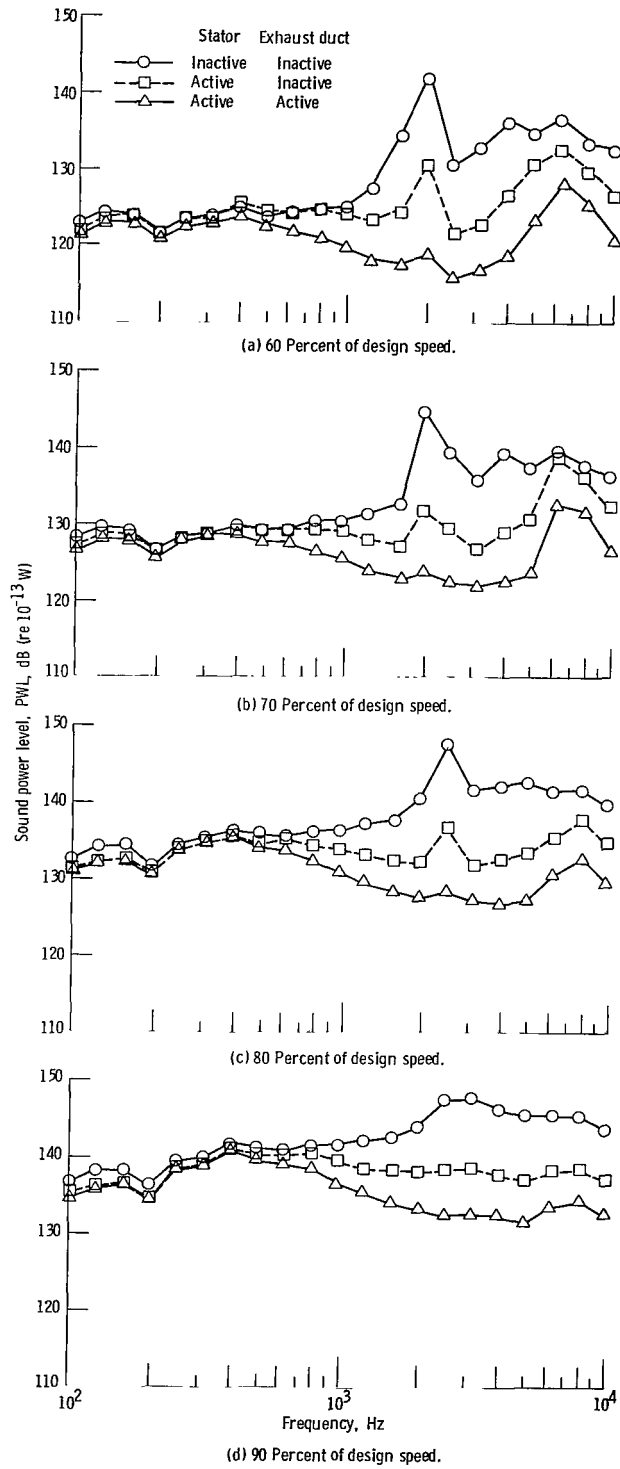

Figure 10. - Rear-hemisphere sound power level variation with frequency for long stator configuration with active three-ring inlet.

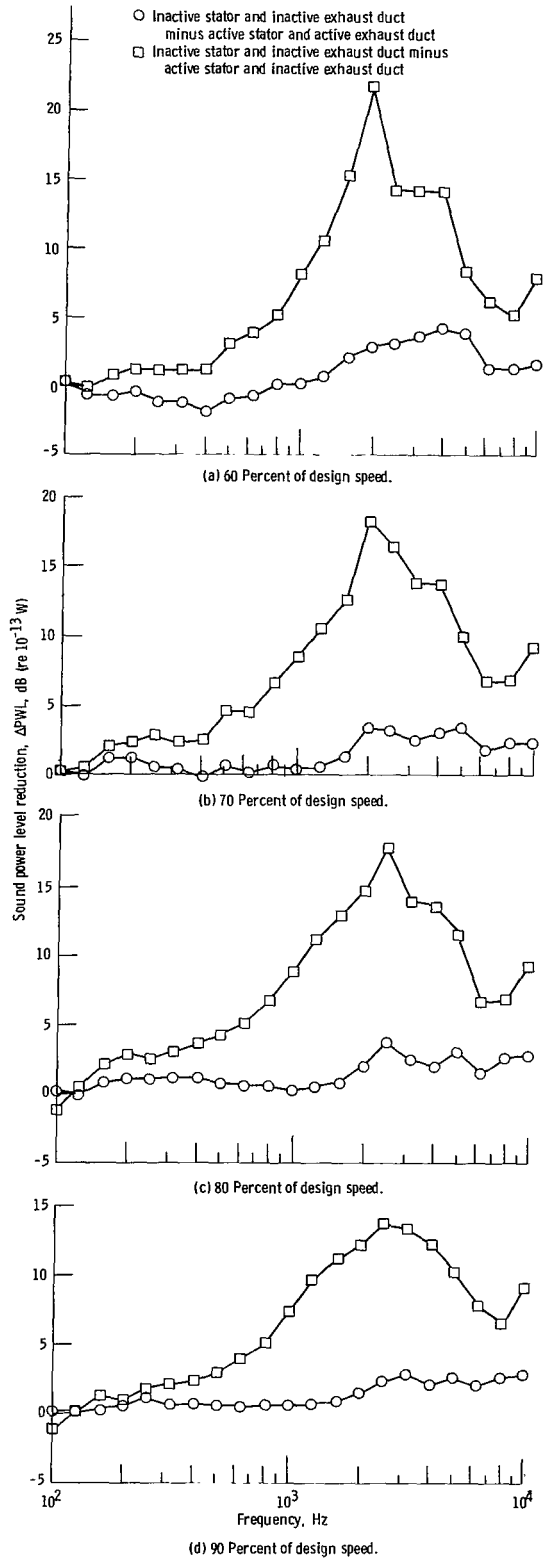

Figure 11. - Rear-hemisphere sound power level reduction with frequency for short stator configuration with active three-ring inlet.

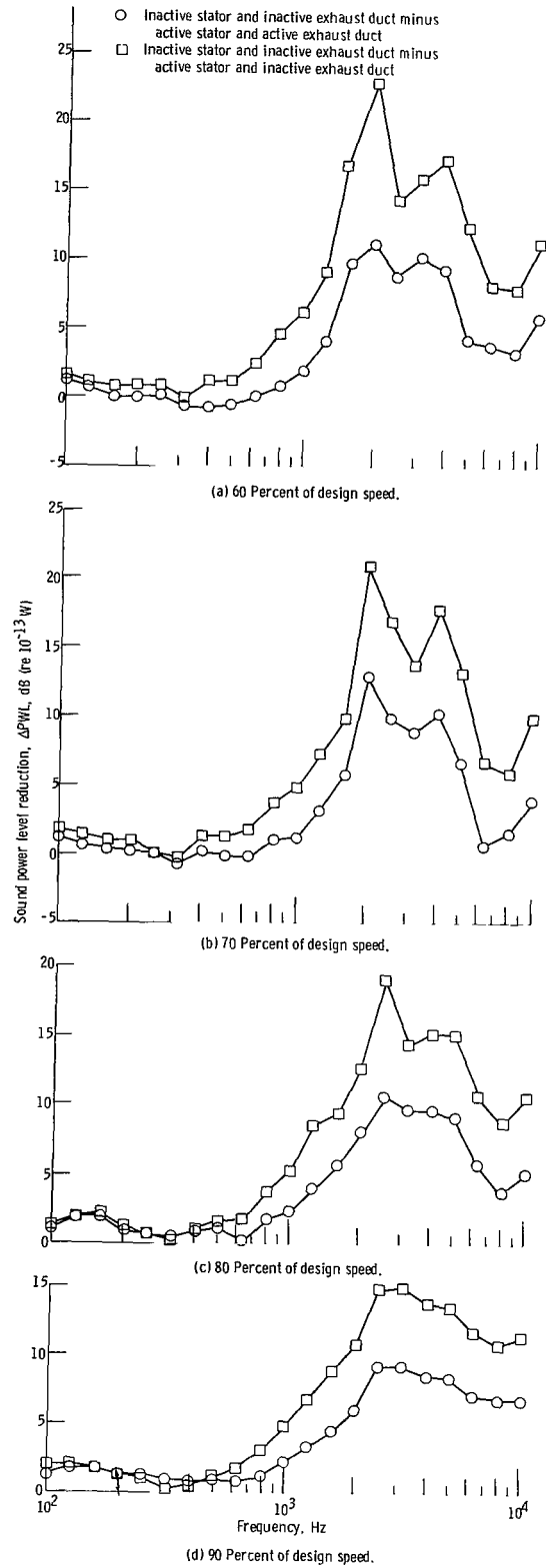

Figure 12. - Rear-hemisphere sound power level reduction with frequency for long stator configuration with active three-ring inlet.

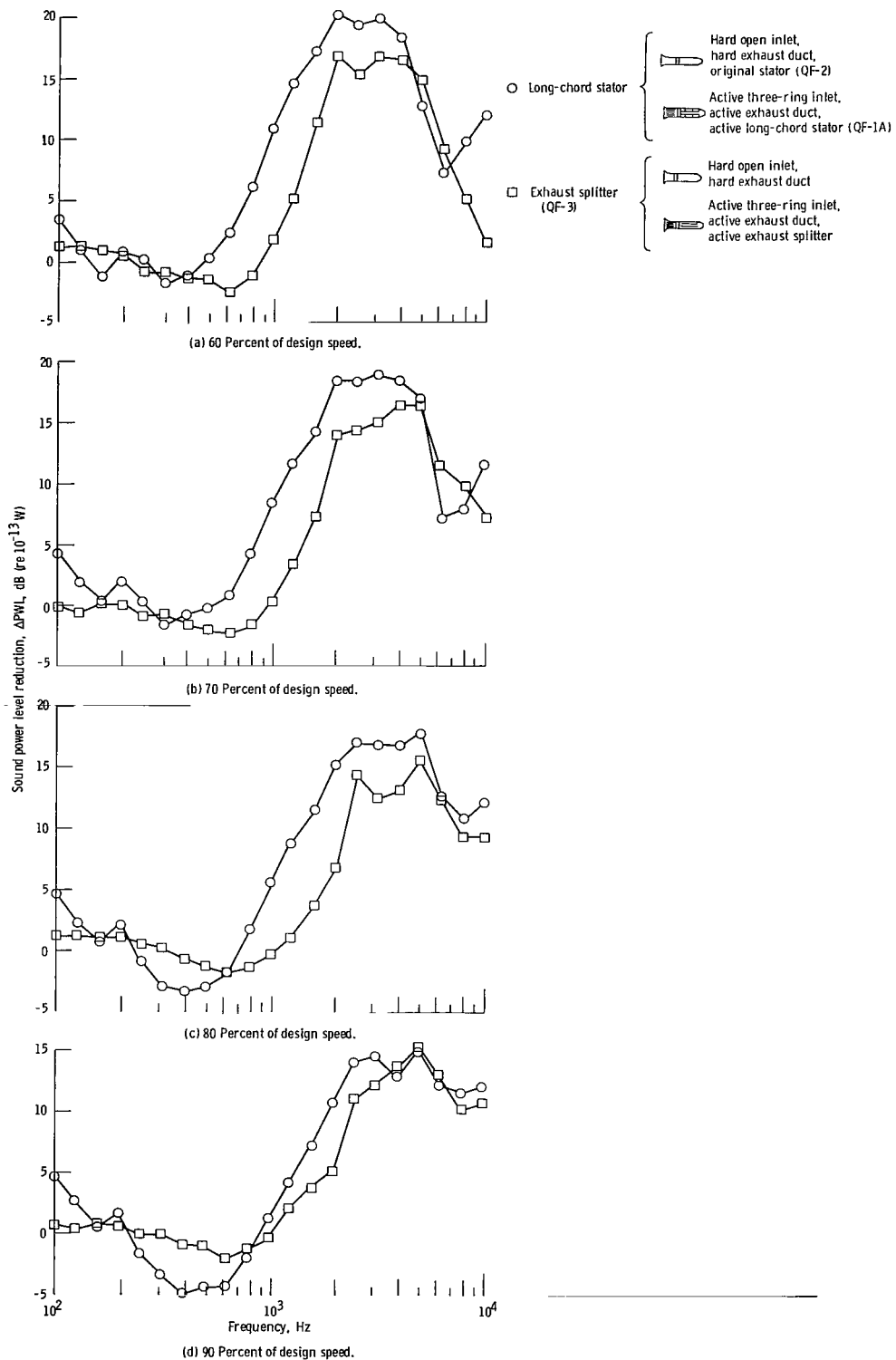

Figure 13. - Comparison of rear-hemisphere sound power level reductions for long-chord stator and exhaust splitter ring.

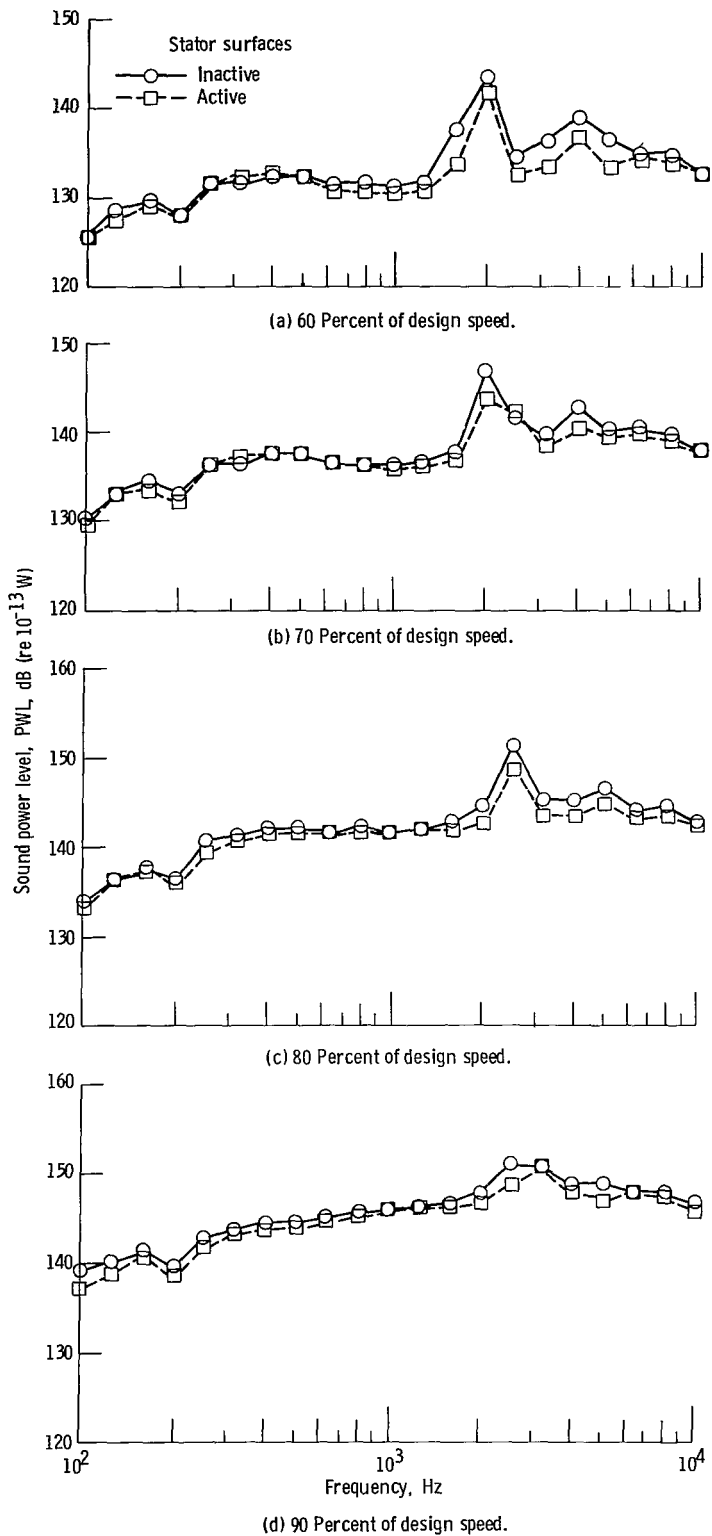

Figure 14. - Total sound power variation with frequency for short stator configuration with inactive inlet and inactive exhaust duct.

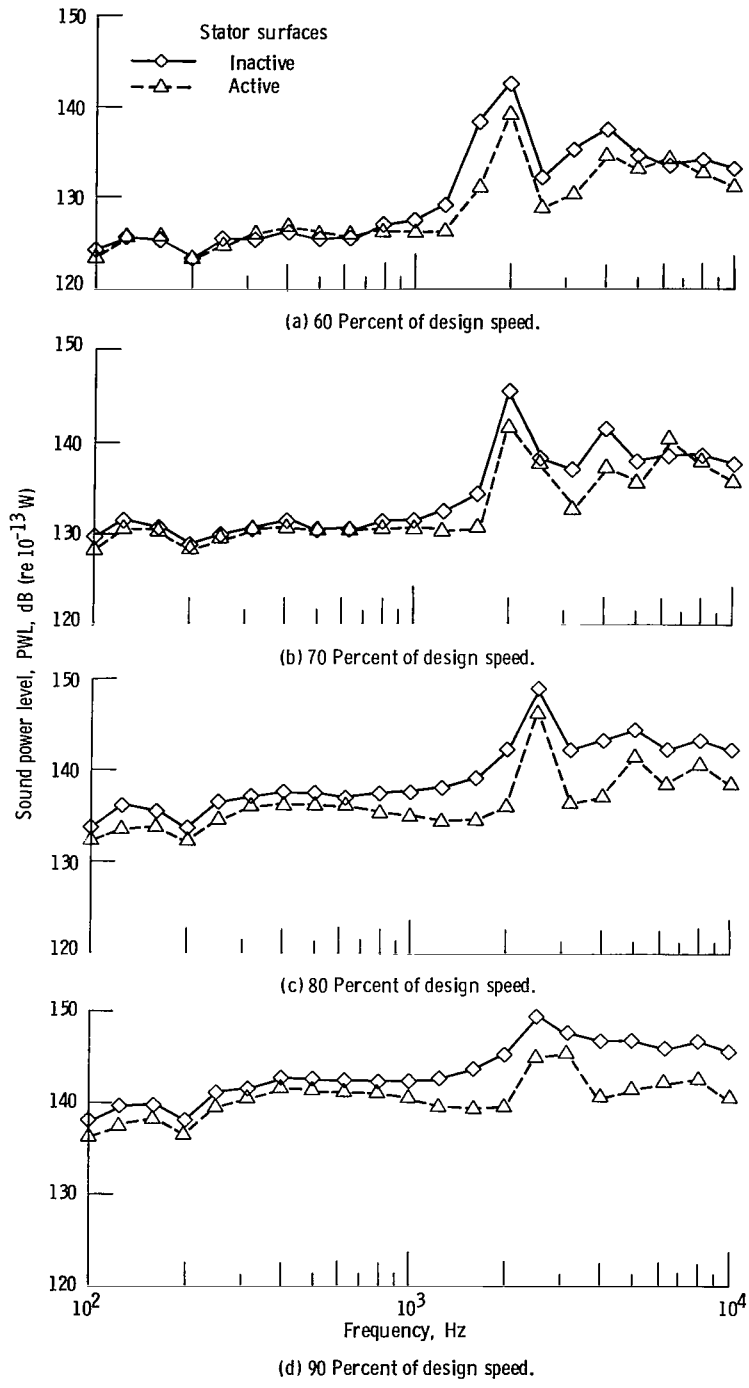

Figure 15. - Total sound power variation with frequency for long stator configuration with inactive inlet and inactive exhaust duct.

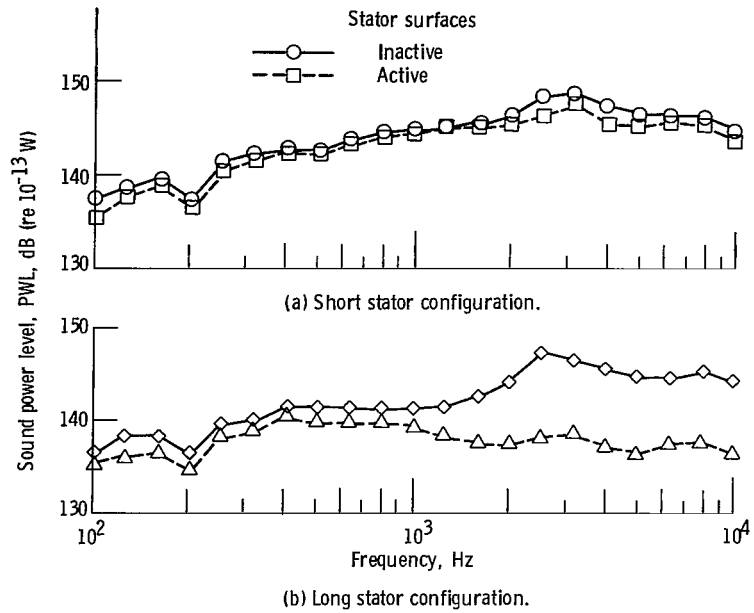

Figure 16. - Rear-hemisphere sound power variation with frequency for inactive inlet and inactive exhaust duct at 90 percent of design speed.

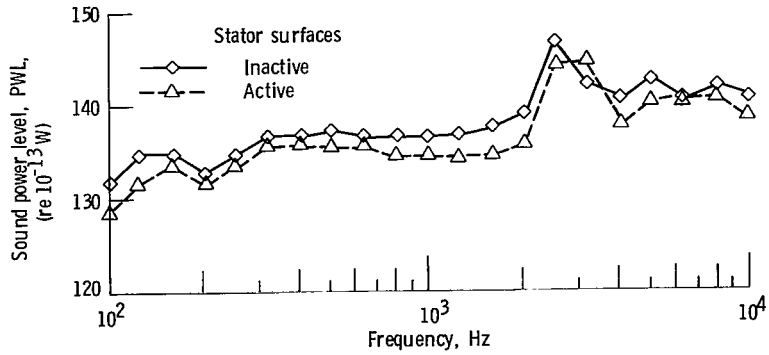

Figure 17. - Front-hemisphere sound power variation with frequency for long stator configuration with inactive inlet and inactive exhaust duct at 90 percent of design speed.

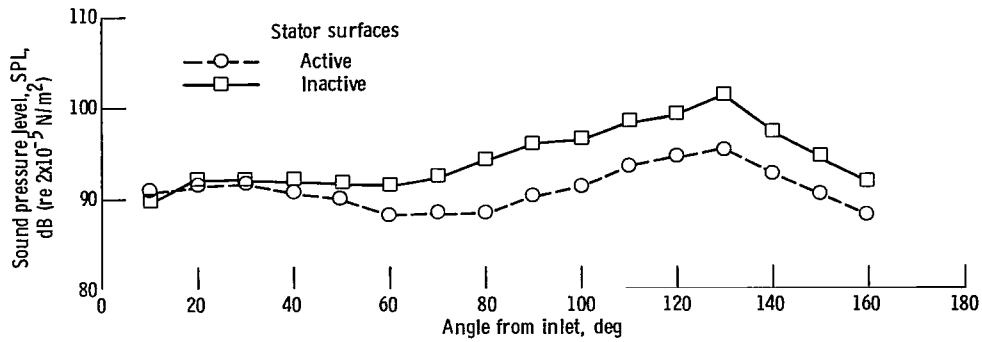

Figure 18. - Sound pressure level variation with angle from inlet for long stator configuration with inactive inlet and inactive exhaust duct - for 1600-hertz-center-frequency, 1/3-octave band at 90 percent of design speed.

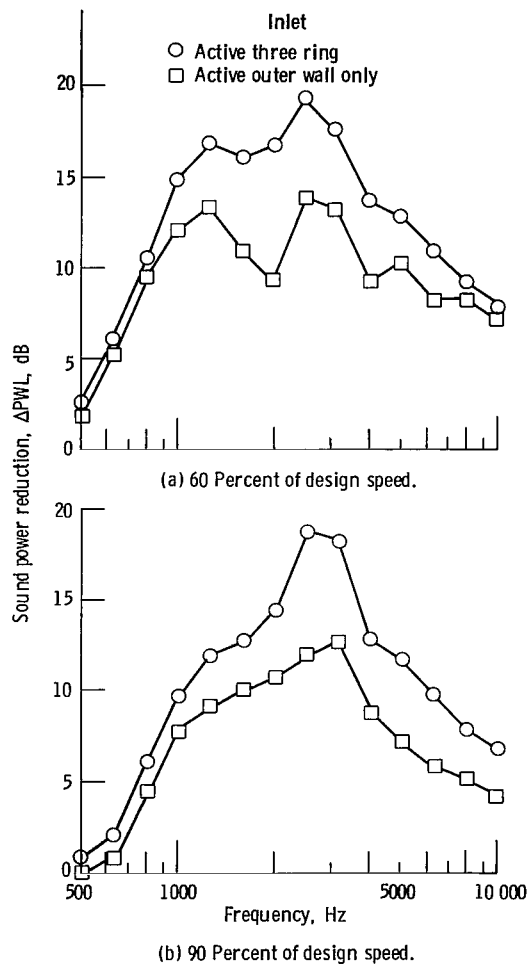

Figure 19. - Front-hemisphere sound power level reductions from original-stator, hard-inlet, hard-exhaust base. Short active stator; active exhaust duct.

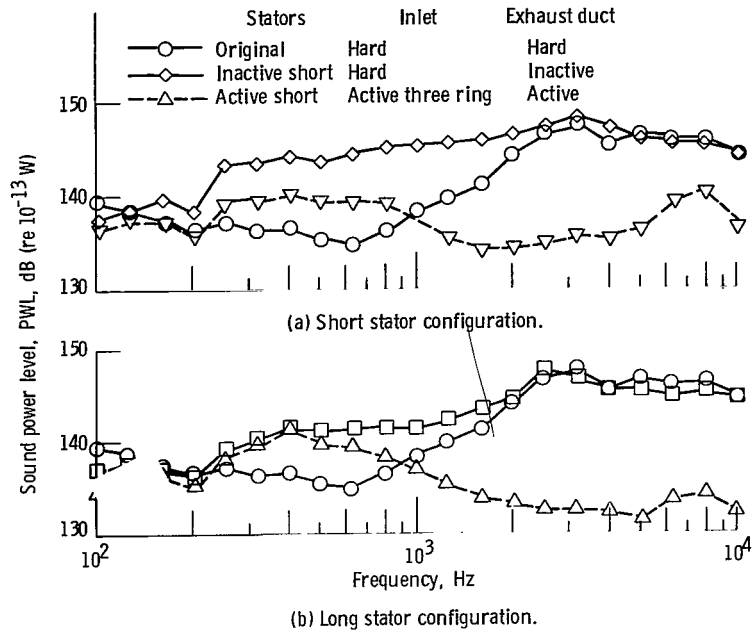

Figure 20. - Rear-hemisphere sound power level variation at 90 percent of design speed.

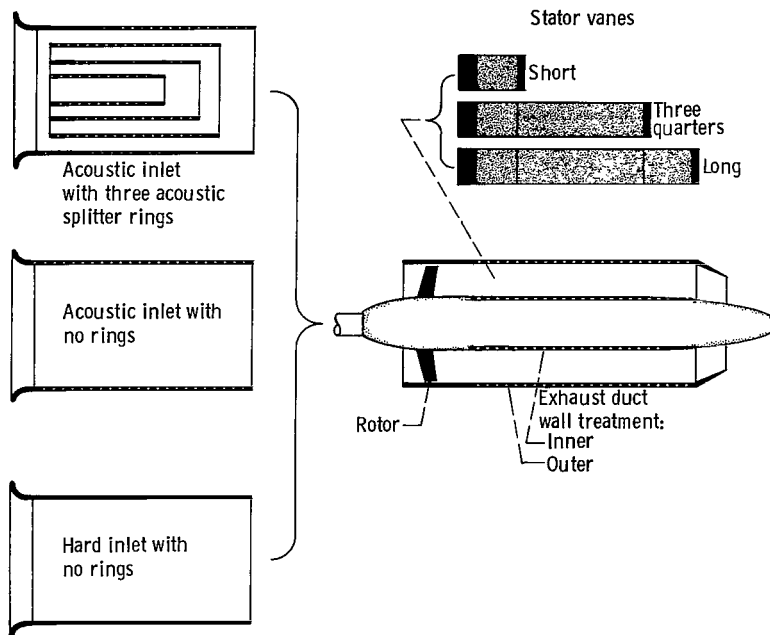

Figure 21. - Configurations.

NATIONAL AERONAUTICS AND SPACE ADMINISTRATION
WASHINGTON, D.C. 20546

OFFICIAL BUSINESS
PENALTY FOR PRIVATE USE \$300

**SPECIAL FOURTH-CLASS RATE
BOOK**

POSTAGE AND FEES PAID
NATIONAL AERONAUTICS AND
SPACE ADMINISTRATION
45



766 001 C1 U A 760910 S00903DS
DEPT OF THE AIR FORCE
AF WEAPONS LABORATORY
ATTN: TECHNICAL LIBRARY (SUL)
KIRTLAND AFB NM 87117

POSTMASTER: If Undeliverable (Section 158
Postal Manual) Do Not Return

"The aeronautical and space activities of the United States shall be conducted so as to contribute . . . to the expansion of human knowledge of phenomena in the atmosphere and space. The Administration shall provide for the widest practicable and appropriate dissemination of information concerning its activities and the results thereof."

—NATIONAL AERONAUTICS AND SPACE ACT OF 1958

NASA SCIENTIFIC AND TECHNICAL PUBLICATIONS

TECHNICAL REPORTS: Scientific and technical information considered important, complete, and a lasting contribution to existing knowledge.

TECHNICAL NOTES: Information less broad in scope but nevertheless of importance as a contribution to existing knowledge.

TECHNICAL MEMORANDUMS: Information receiving limited distribution because of preliminary data, security classification, or other reasons. Also includes conference proceedings with either limited or unlimited distribution.

CONTRACTOR REPORTS: Scientific and technical information generated under a NASA contract or grant and considered an important contribution to existing knowledge.

TECHNICAL TRANSLATIONS: Information published in a foreign language considered to merit NASA distribution in English.

SPECIAL PUBLICATIONS: Information derived from or of value to NASA activities. Publications include final reports of major projects, monographs, data compilations, handbooks, sourcebooks, and special bibliographies.

TECHNOLOGY UTILIZATION PUBLICATIONS: Information on technology used by NASA that may be of particular interest in commercial and other non-aerospace applications. Publications include Tech Briefs, Technology Utilization Reports and Technology Surveys.

Details on the availability of these publications may be obtained from:

SCIENTIFIC AND TECHNICAL INFORMATION OFFICE

NATIONAL AERONAUTICS AND SPACE ADMINISTRATION

Washington, D.C. 20546