

**TECHNICAL
MEMORANDUM**

NASA TM X- 73957-5

NASA TM X- 73957-5

(NASA-TM-X-73957-5) LaRC DESIGN ANALYSIS
REPORT FOR NATIONAL TRANSONIC FACILITY FOR
304 STAINLESS STEEL TUNNEL SHELL. VOLUME
5S: FINITE ELEMENT AND NUMERICAL
INTEGRATION ANALYSES OF THE BULKHEAD REGION

N76-33556
HC 59.25
Unclas
07181

LaRC DESIGN ANALYSIS REPORT
FOR
NATIONAL TRANSONIC FACILITY
FOR
304 STAINLESS STEEL TUNNEL SHELL
FINITE ELEMENT AND NUMERICAL INTEGRATION ANALYSES
OF THE BULKHEAD REGION

VOL. 5S

BY

JAMES W. RAMSEY, JR., JOHN T. TAYLOR, JOHN F. WILSON,
CARL E. GRAY, JR., ANNE D. LEATHERMAN, JAMES R. ROOKER,
AND JOHNNY W. ALLRED

This informal documentation medium is used to provide accelerated or special release of technical information to selected users. The contents may not meet NASA formal editing and publication standards, may be revised, or may be incorporated in another publication.

NASA
National Aeronautics and
Space Administration
Langley Research Center
Hampton, Virginia 23665



1. Report No. TM X-73957-5	2. Government Accession No.	3. Recipient's Catalog No.	
4. Title and Subtitle LaRC Design Analysis Report for the National Transonic Facility for a 304 Stainless Steel Tunnel Shell - Finite Element and Numerical Integration Analyses of the Bulkhead Region, Vol. 5S		5. Report Date September 1976	6. Performing Organization Code
		8. Performing Organization Report No.	10. Work Unit No.
7. Author(s) J. W. Ramsey, Jr., J. T. Taylor, J. F. Wilson, C. E. Gray, Jr., A. D. Leatherman, J. R. Rooker, and J. W. Allred		11. Contract or Grant No.	
		13. Type of Report and Period Covered Technical Memorandum X	
9. Performing Organization Name and Address National Aeronautics and Space Administration Langley Research Center Hampton, Virginia 23665		14. Sponsoring Agency Code	
12. Sponsoring Agency Name and Address National Aeronautics and Space Administration Washington, DC 20546		15. Supplementary Notes Formal Documentation of Design Analyses to Obtain Code Approval of Fabricated National Transonic Facility	
16. Abstract This report contains the results of extensive computer (finite element, finite difference and numerical integration), thermal, fatigue, and special analyses of critical portions of a large pressurized, cryogenic wind tunnel (National Transonic Facility). The computer models, loading and boundary conditions are described. Graphic capability was used to display model geometry, section properties, and stress results. A stress criteria is presented for evaluation of the results of the analyses. Thermal analyses were performed for major critical and typical areas. Fatigue analyses of the entire tunnel circuit is presented. The major computer codes utilized are: SPAR - developed by Engineering Information Systems, Inc. under NASA Contracts NAS8-30536 and NAS1-13977; SALORS - developed by Langley Research Center and described in NASA TN D-7179; and SRA - developed by Structures Research Associates under NASA Contract NAS1-10091; "A General Transient Heat-Transfer Computer Program for Thermally Thick Walls" developed by Langley Research Center and described in NASA TM X-2058.			
17. Key Words (Suggested by Author(s)) Pressure Vessel Wind Tunnel Finite Element Numerical Integration Design		18. Distribution Statement UNCLASSIFIED - UNLIMITED	
19. Security Classif. (of this report) Unclassified	20. Security Classif. (of this page) Unclassified	21. No. of Pages 290	22. Price* \$8.75

NATIONAL TRANSONIC FACILITY

TUNNEL SHELL

NASA - LARC

FINITE ELEMENT
AND
NUMERICAL INTEGRATION ANALYSES
OF THE
BULKHEAD REGION

304 STAINLESS STEEL

SEPTEMBER 1976

VOLUME 5S

LaRC CALCULATIONS
FOR THE
NATIONAL TRANSONIC FACILITY
TUNNEL SHELL

DATE: SEPTEMBER, 1976

APPROVED:

James W. Ramsey, Jr.
DR. JAMES W. RAMSEY, JR., HEAD
STRUCTURAL ENGINEERING SECTION

ANALYSTS:

John T. Taylor
JOHN T. TAYLOR
HEAD SHELL ANALYST

John F. Wilson
JOHN F. WILSON, SHELL WORK
PACKAGE & CONSTRUCTION MANAGER

Carl E. Gray, Jr.
CARL E. GRAY, JR.
SHELL ANALYST

Anne D. Leatherman
ANNE D. LEATHERMAN
SHELL PROGRAMMER

James R. Rooker
JAMES R. ROOKER
SHELL/THERMAL ANALYST

Johnny W. Allred
JOHNNY W. ALLRED
SHELL/THERMAL ANALYST

This report is one volume of a Design Analysis Report prepared by LaRC on portions of the pressure shell for the National Transonic Facility. This report is to be used in conjunction with reports prepared under NASA Contract NAS1-13535(c) by the Ralph M. Parsons Company (Job Number 5409-3 dated September 1976) and Fluidyne Engineering Corporation (Job Number 1060 dated September 1976). The volumes prepared by LaRC are listed below:

1. Finite Difference Analysis of Cone/Cylinder Junction (304 S.S.) Vol. 1, NASA TM X-73957-1.
2. Finite Element Analysis of Corners #3 and #4 (304 S.S.), Vol. 2S, NASA TM X-73957-2.
3. Finite Element Analysis of Plenum Region Including Side Access Reinforcement, Side Access Door and Angle of Attack Penetration (304 S.S.), Vol. 3S, NASA TM X73957-3.
4. Thermal Analysis (304 S.S.) Vol. 4S, NASA TM X73957-4.
5. Finite Element and Numerical Integration Analyses of the Bulkhead Region (304 S.S.), Vol. 5S, NASA TM X73957-5.
6. Fatigue Analysis (304 S.S.), Vol. 6S, NASA TM X73957-6.
7. Special Studies (304 S.S.), Vol. 7S, NASA TM X73957-7.

NTF DESIGN CRITERIA
FOR 304 STAINLESS STEEL

GENERAL

THE DESIGN OF THE PRESSURE SHELL REFLECTED IN THIS REPORT SATISFIES THE DESIGN REQUIREMENTS OF THE ASME BOILER AND PRESSURE VESSEL CODE, SECTION VIII, DIVISION 1. SINCE DIVISION 1 DOES NOT CONTAIN RULES TO COVER ALL DETAILS OF DESIGN, ADDITIONAL ANALYSES WERE PERFORMED IN AREAS HAVING COMPLEX CONFIGURATIONS SUCH AS THE CONE CYLINDER JUNCTIONS, THE GATE VALVE BULKHEADS, THE BULKHEAD-SHELL ATTACHMENTS, THE PLENUM ACCESS DOORS AND REINFORCEMENT AREAS, THE ELLIPTICAL CORNER SECTIONS, AND THE FIXED REGION (RING S8) OF THE TUNNEL. THE DIVISION 1 DESIGN CALCULATIONS, THE ADDITIONAL ANALYSES AND THE CRITERIA FOR EVALUATION OF THE RESULTS OF THE ADDITIONAL ANALYSES TO ENSURE COMPLIANCE WITH THE INTENT OF DIVISION 1 REQUIREMENTS ARE CONTAINED IN THE TEXT OF THIS REPORT. THE DESIGN ANALYSES AND ASSOCIATED CRITERIA CONSIDERED BOTH THE OPERATING AND HYDROSTATIC TEST CONDITIONS.

IN CONJUNCTION WITH THE DESIGN, A DETAILED FATIGUE ANALYSIS OF THE PRESSURE SHELL WAS ALSO PERFORMED UTILIZING THE METHODS OF THE ASME CODE, SECTION VIII, DIVISION 2.

MATERIAL

THE PRESSURE SHELL MATERIAL SHALL BE ASME, SA-240, GRADE 304 FOR PLATE AND SA-182, GRADE F304 FOR FORGINGS. THE MATERIAL PROPERTIES AT TEMPERATURES EQUAL TO OR BELOW 150°F ARE AS FOLLOWS:

(A) PLATE

YIELD = 30.0 KSI
ULTIMATE = 75.0 KSI

(B) WELDS (AUTOMATIC, SEMIAUTOMATIC, OR "STICK")

YIELD = 30.0 KSI
ULTIMATE = 75.0 KSI

OPERATING, DESIGN AND TEST CONDITIONS

THE OPERATING, DESIGN AND TEST CONDITIONS FOR THE TUNNEL PRESSURE SHELL AND ASSOCIATED SYSTEMS AND ELEMENTS ARE SUMMARIZED BELOW:

1. OPERATING MEDIUM

ANY MIXTURE OF AIR AND NITROGEN

2. DESIGN TEMPERATURE RANGE

MINUS 320 DEGREES FAHRENHEIT TO PLUS 150 DEGREES FAHRENHEIT, EXCEPT IN THE REGION OF THE PLENUM BULKHEADS AND GATE VALVES INSIDE A 23-FOOT, 4-INCH DIAMETER, FOR WHICH THE TEMPERATURE RANGE IS MINUS 320 DEGREES FAHRENHEIT TO PLUS 200 DEGREES FAHRENHEIT.

3. PRESSURE RANGE

TUNNEL CONFIGURATION	OPERATING PRESSURE RANGE, PSIA	DESIGN PRESSURES PSID
A. CONDITION I - PLENUM ISOLATION GATES OPEN AND TUNNEL OPERATING:		
TUNNEL CIRCUIT EXCEPT PLENUM	8.3 to 130	A. 8 EXTERNAL B. 119 INTERNAL
PLENUM (PLENUM PRESSURE IS LIMITED TO .4 TO 1 TIMES THE REMAINDER OF THE TUNNEL CIRCUIT	3.3 to 130	A. 15 EXTERNAL B. 119 INTERNAL
BULKHEAD		56 (EXTERNAL TO PLENUM)
B. CONDITION II - PLENUM ISOLATION GATES OPEN AND TUNNEL SHUTDOWN:		
ENTIRE TUNNEL CIRCUIT	8.3 to 130	A. 8 EXTERNAL B. 119 INTERNAL
BULKHEAD		0
C. CONDITION III - PLENUM ISOLATION GATES AND ACCESS DOORS CLOSED:		
TUNNEL CIRCUIT EXCEPT PLENUM	8.3 to 130	A. 8 EXTERNAL B. 119 INTERNAL

PLENUM (PLENUM OPERATING PRESSURE CAN EXCEED THE PRESSURE IN THE REMAINDER OF THE TUNNEL CIRCUIT BY 24 PSI, BUT DOES NOT EXCEED THE 130 PSIA MAXIMUM OPERATING PRESSURE)

0 to 130

- A. 15 EXTERNAL
- B. 119 INTERNAL

BULKHEAD

- A. 25 (INTERNAL TO PLENUM)
- B. 119 (EXTERNAL TO PLENUM) FOR MINUS 320 DEGREES FAHRENHEIT TO PLUS 150 DEGREES FAHRENHEIT

- *C. 115.7 (EXTERNAL TO PLENUM) FOR PLUS 151 DEGREES FAHRENHEIT TO PLUS 200 DEGREES FAHRENHEIT

*OPERATING PROCEDURES LIMIT PRESSURES TO THAT SHOWN.

D. CONDITION IV - PLENUM ISOLATION GATES CLOSED AND ACCESS DOORS OPEN:

TUNNEL CIRCUIT EXCEPT PLENUM

8.3 to 130

- A. 8 EXTERNAL
- B. 119 INTERNAL

PLENUM

14.7

0

BULKHEAD

- A. 119 (EXTERNAL TO PLENUM) FOR MINUS 320 DEGREES FAHRENHEIT TO PLUS 150 DEGREES FAHRENHEIT
- *B. 115.7 (EXTERNAL TO PLENUM) FOR PLUS 151 DEGREES FAHRENHEIT TO PLUS 200 DEGREES FAHRENHEIT

*OPERATING PROCEDURES LIMIT PRESSURES TO THAT SHOWN.

4. HYDROSTATIC TEST DESIGN CONDITIONS

THE PRESSURE SHELL WAS DESIGNED FOR HYDROSTATIC TEST IN ACCORDANCE WITH THE REQUIREMENTS OF THE ASME CODE, SECTION VIII, DIVISION 1. THE TEST PRESSURES SHALL BE AS FOLLOWS. PRESSURE SHELL TEMPERATURE SHALL BE EQUAL TO OR BELOW 100°F DURING HYDROSTATIC TESTS.

CONDITION (1) - MAXIMUM INTERNAL PRESSURE CONDITION FOR THE ENTIRE TUNNEL CIRCUIT

$$\begin{aligned}PH_1 &= 1.5 (119) \left(\frac{18.7}{18.2}\right) + \text{HYDROSTATIC HEAD} \\ &= 183.4 \text{ PSI} + \text{HYDROSTATIC HEAD}\end{aligned}$$

CONDITION (2) - MAXIMUM DIFFERENTIAL PRESSURE CONDITION ACROSS THE PLENUM BULKHEADS

$$\begin{aligned}PH_2 &= 1.5 \left(\frac{18.7}{18.2}\right) (119) + \text{HYDROSTATIC HEAD} \\ &= 183.4 + \text{HYDROSTATIC HEAD}\end{aligned}$$

$$\begin{aligned}PH_2^* &= 1.5 (115.7) \left(\frac{18.7}{17.7}\right) + \text{HYDROSTATIC HEAD} \\ &= 183.4 + \text{HYDROSTATIC HEAD}\end{aligned}$$

*TUNNEL OPERATION LIMITATIONS PRECLUDE PRESSURE DIFFERENTIALS ACROSS BULKHEADS IN EXCESS OF 115.7 PSI FOR BULKHEAD AND GATE TEMPERATURES IN EXCESS OF 150°F.

CONDITION (3) - MAXIMUM REVERSE DIFFERENTIAL PRESSURE CONDITION ACROSS THE PLENUM BULKHEADS

$$PH_3 = 1.5 \left(\frac{29.7}{18.2}\right) (25) = 38.5 \text{ PSI}$$

THE PRESSURE SHELL EXCEPT FOR THE PLENUM SHALL BE PRESSURIZED TO 144.9 PSIG. THE PLENUM SHALL BE PRESSURIZED TO 183.4 PSIG.

PRESSURE SHELL STRESS EVALUATION CRITERIA

THIS CRITERIA ESTABLISHES THE BASIS FOR ANALYSIS AND DESIGN OF THE PRESSURE SHELL SO IT WILL MEET OR EXCEED ALL OF THE REQUIREMENTS OF SECTION VIII, DIVISION 1 OF THE ASME BOILER AND PRESSURE VESSEL CODE AND CAN BE STAMPED WITH A DIVISION 1 "U" STAMP.

1. SECTION VIII, DIVISION 1, DIRECT APPLICATION

(A) THE MAXIMUM ALLOWABLE STRESS (S)

$$S = 18.2 \text{ KSI } (-320^{\circ}\text{F TO } +150^{\circ}\text{F})$$

$$S = 17.7 \text{ KSI } (-320^{\circ}\text{F TO } +200^{\circ}\text{F})$$

(B) PRIMARY BENDING PLUS PRIMARY MEMBRANE STRESSES

THE LOCAL MEMBRANE STRESSES ARE NOT GENERALLY CONSIDERED IN SECTION VIII, DIVISION 1 DESIGNS. HOWEVER, FOR THE PURPOSE OF DESIGNING LOCAL REINFORCEMENT AT BRACKETS, RINGS OR PENETRATIONS NOT COVERED BY DESIGN BASED ON STRESS ANALYSIS, THE LOCAL SHELL MEMBRANE STRESS SHALL BE:

$$P_b + P_m \leq 1.5 SE$$

NOTE: E IS JOINT EFFICIENCY

2. IN REGIONS OF THE PRESSURE SHELL WHERE DIVISION 1 DOES NOT CONTAIN RULES TO COVER ALL DETAILS OF DESIGN (REF. U-2(g)), ADDITIONAL ANALYSES WERE PERFORMED UTILIZING THE GUIDELINES OF THE ASME CODE, SECTION VIII, DIVISION 2, APPENDIX 4, "DESIGN BASED ON STRESS ANALYSIS." THE BASIC STRESS CRITERIA FOR DIVISION 2 IS REPRESENTED IN FIGURE 4-130.1 AND RESTATED BELOW INDICATING ANY MODIFICATIONS OR EXCESS REQUIREMENTS APPLIED TO IT TO REMAIN WITHIN THE INTENT OF DIVISION 1 AND TO OBTAIN A DIVISION 1 STAMP.

A. GENERAL PRINCIPAL MEMBRANE STRESS

MAXIMUM ALLOWABLE STRESS

$$S = 18.2 \text{ KSI } (-320^{\circ}\text{F TO } +150^{\circ}\text{F})$$

$$S = 17.7 \text{ KSI } (-320^{\circ}\text{F TO } +200^{\circ}\text{F})$$

MAXIMUM ALLOWABLE STRESS INTENSITY

$$S_m = 20.0 \text{ KSI } (-320^{\circ}\text{F TO } +300^{\circ}\text{F})$$

B. PRIMARY GENERAL MEMBRANE STRESS INTENSITY

$$P_m \leq S_m$$

AND IN ORDER TO COMPLY WITH DIVISION 1, THE MAXIMUM PRINCIPAL MEMBRANE STRESS MUST BE:

$$P_m^* \leq S$$

NOTE: THE * IS USED TO DENOTE THAT MAXIMUM PRINCIPAL STRESSES ARE TO BE COMPUTED FOR THE GIVEN LOADING CONDITION. THE INTENT IS TO DETERMINE THE STRESSES WHICH REPRESENT THE HOOP STRESSES AND MERIDIONAL STRESSES WHICH ARE THE STRESSES USED IN DIVISION 1 COMPUTATIONS.

C. DESIGN LOADS, PRIMARY LOCAL MEMBRANE STRESS INTENSITY

$$P_L \leq 1.5 S_m$$

NOTE: LOCAL MEMBRANE STRESS INTENSITY IS DEFINED IN ACCORDANCE WITH DIVISION 2, APPENDIX 4-112(i). THE TOTAL MERIDIONAL LENGTH IS CONSIDERED TO BE $1.0 \sqrt{RT}$.

D. DESIGN LOADS, PRIMARY LOCAL MEMBRANE PLUS PRIMARY BENDING STRESS INTENSITY

$$P_L + P_b \leq 1.5 S_m$$

E. OPERATING LOADS, PRIMARY PLUS SECONDARY STRESS INTENSITY

$$P_L + P_b + Q \leq 3 S_m$$

3. A FATIGUE ANALYSIS WAS CONDUCTED IN ACCORDANCE WITH SECTION VIII, DIVISION 2 WITHOUT MODIFICATION.

4. HYDROSTATIC TEST CONDITION DESIGN CONSIDERATIONS

A. PRESSURE SHELL

IN ACCORDANCE WITH DIVISION 1 OF THE ASME CODE, DESIGN ANALYSIS OF THE PRESSURE SHELL FOR THE HYDROSTATIC TEST CONDITION IS NOT REQUIRED. HOWEVER, IN ORDER TO PROVIDE A SATISFACTORY ENGINEERING DESIGN FOR THE PRESSURE SHELL SPECIAL EMPHASIS WAS GIVEN, AS PROMPTED BY NOTE (1) OF SECTION VIII, DIVISION 1 OF THE ASME CODE, TO FLANGES OF GASKETED JOINTS OR OTHER APPLICATIONS WHERE SLIGHT AMOUNTS OF DISTORTION CAN CAUSE LEAKAGE OR MALFUNCTION. EXAMPLES OF THESE AREAS ARE THE PLENUM, PLENUM ACCESS DOORS, PLENUM ACCESS DOOR REINFORCEMENT, THE BULKHEADS, AND BULKHEAD FLANGES.

B. SUPPORT RINGS

DESIGN OF THE PRESSURE SHELL SUPPORT RINGS, INCLUDING

THE CORNER RINGS, FOR THE HYDROSTATIC TEST CONDITION, COMPLIES WITH THE FOLLOWING:

- (A) THE COMBINED VALUE OF THE SHELL CIRCUMFERENTIAL PRESSURE STRESS, S_1 AND SHELL BENDING STRESS S_2 , RESULTING FROM ACTION OF A PORTION OF THE SHELL AS AN INNER FLANGE OF THE RING, SHALL NOT EXCEED 0.8 WELD YIELD STRESS:

$$S_1 + S_2 \leq 0.8 \text{ WELD YIELD STRESS,}$$

WHERE, FOR SUPPORT RINGS NOT ANALYZED BY FINITE ELEMENT TECHNIQUES,

$$S_1 = P_H \left(\frac{R}{T} \right) + .6 P_H; P_H \text{ INCLUDES HYDROSTATIC HEAD CORRECTION, AND}$$

S_2 = RING BENDING STRESS AT INNER FLANGE, BASED ON AN EFFECTIVE WIDTH OF THE PRESSURE SHELL ACTING AS AN INNER FLANGE OF THE RING OF 1.1 MULTIPLIED BY THE SQUARE ROOT OF $D_o T$.

- (B) THE BENDING STRESS, S_{2F} ON THE OUTSIDE FLANGE SHALL NOT EXCEED .9 WELD YIELD STRESS. (IN THE COMPUTER ANALYSIS ALL LOADING CONDITIONS ARE LIMITED TO .9 S_Y ON THE OUTER FLANGE.)
- (C) BRACKETS AND SUPPORT PAD WELDMENTS

THE DESIGN FOR ALL LOADING CONDITIONS INCLUDING THE HYDROSTATIC TEST CONDITION OF THOSE PORTIONS OF BRACKETS AND SUPPORT PAD WELDMENTS WHICH ARE ATTACHED TO THE PRESSURE SHELL BUT NOT ON THE SURFACE OF THE SHELL SHALL COMPLY WITH THE REQUIREMENTS OF THE AISC CODE, I.E. MAXIMUM STRESS IN TENSION EQUALS .6 S_Y , ETC.

VOL. 59

NTF BULKHEAD - 30455

	<u>Page</u>
I SKETCH OF REGION OF ANALYSIS	1
II DESCRIPTION OF COMPUTER CODES	2
III SPAR MODEL DESCRIPTION	3
A CONSTRAINTS	4
B MODEL GEOMETRY	7
C LOADING CASES	13
a. CASE 1 - GATE VALVE CLOSED	16
b. CASE 2 - GATE VALVE OPEN	17
c. CASE 3 - FULL PRESSURE	18
d. CASE 4 - GATE VALVE CLOSED W/ STEADY STATE TEMPERATURE	19
e. CASE 5 - GATE VALVE CLOSED W/ TRANSIENT TEMPERATURE	20
D STRESS AND DISPLACEMENT RESULTS	21
a. CASE 1 - run no. LAK	22
b. CASE 2 - run no. LEH	31
c. CASE 3 - run no. AAV	33
d. CASE 4 - run no. LAD	34
e. CASE 5 - run no. AAK	41

<u>IV</u>	SRA MODEL DESCRIPTION	55
	(for buckling analysis)	
A.	CONSTRAINTS	56
B.	MODEL GEOMETRY	57
C.	LOADING CASES	59
a.	CASE 1 - GATE VALVE CLOSED	60
b.	CASE 2 - GATE VALVE CLOSED W/ 30 MIN. TRANSIENT TEMP.	61
c.	CASE 2 - GATE VALVE CLOSED W/ 4 HR. TRANSIENT TEMP.	63
D.	STRESS AND BUCKLING RESULTS	65
a.	CASE 1 - run no. AGE	67
b.	CASE 2 - run no. NMW	75
c.	CASE 3 - run no. ESS	82
<u>V</u>	S4 AND S5 RING ANALYSIS	88

BY _____ DATE _____
CHKD. BY _____ DATE _____

SUBJECT NTF
Analysis of Bulkhead

SHEET NO. 1 OF _____
JOB NO. _____

Reference drawing no. LE-9444325

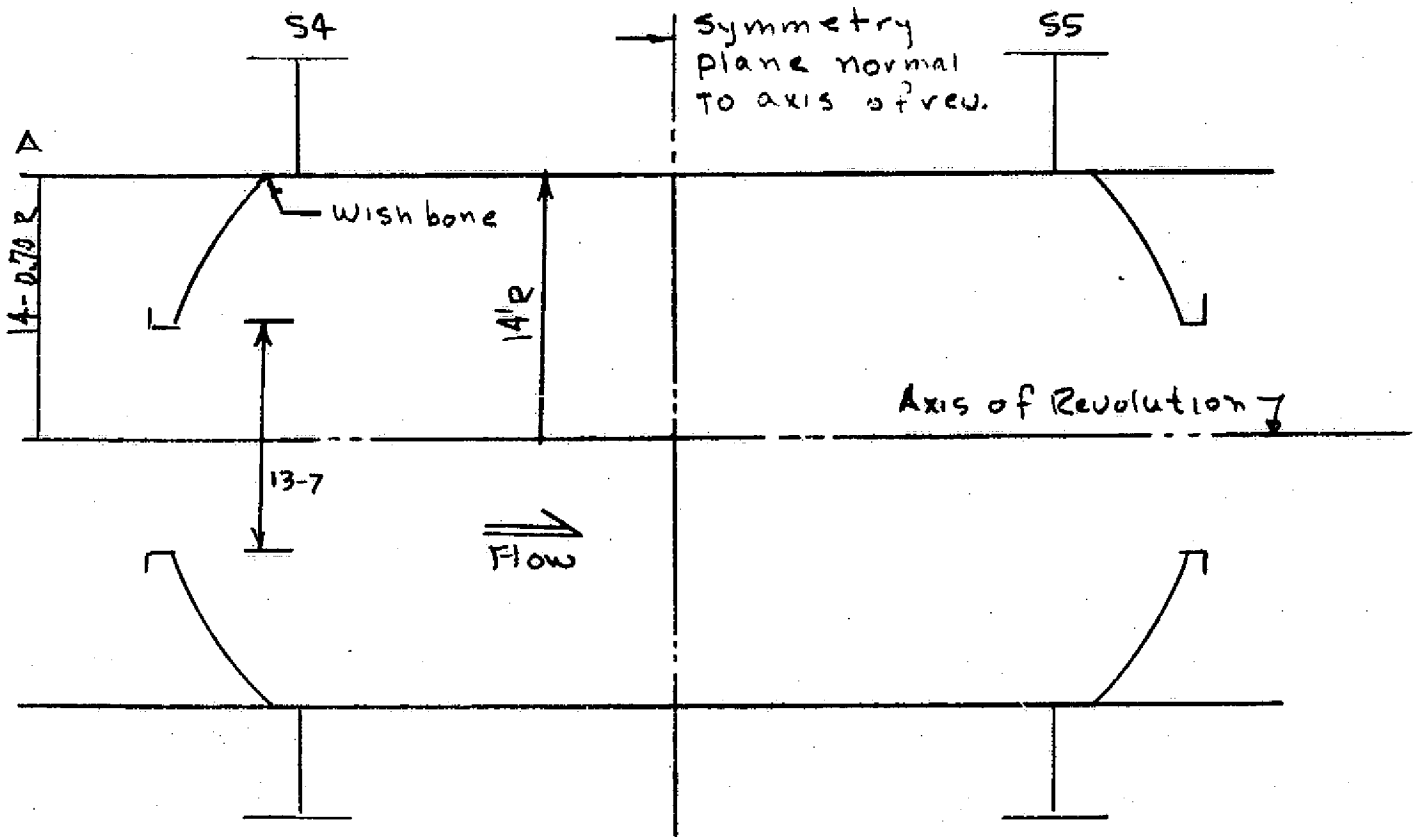

i. Spar; a finite element computer code developed and maintained by Engineering Information System, Inc. Under NASA Contracts:

a. NASB - 30536

b. NASI - 13977.

ii. SRA; a Shells of Revolution Computer Code based on a technique of forward integration.

Prepared under Contract

NASI-10091,

by Structures Research Associates.

The above two codes were used to model this region of the tunnel, from point A to the symmetric plane normal to the axis of revolution.

Spar model description.

Due to a high degree of interconnectivity in the bulkhead / cylindrical shell intersection, and axial symmetry a quarter model using forty elements around the circumference was generated.

See figure 1 for a computer plot of the basic geometric construction of the model. Also, shown on the model for orientation purposes is the right-handed orthogonal basis used in defining;

- a. rigid body constraints
- b. model geometry
- c. direction of all discrete loads

rigid body constraints.

Constraints were imposed on the model for the following reasons:

1. To maintain static equilibrium. The axial displacement on the model had to be removed, to generate a state of equilibrium. This was accomplished by modeling the effective spring rate, from the end of the model to the axis of symmetry normal to the shell, as rods. Then fixing the end of the rods on the axis of symmetry. Thus, any axial forces that were required to set up the proper stress state in the shell elements would be self generating. (see figure 2) Changing the spring rates was found to have no effect on the general structure. This simply caused the model to seek a new relative equilibrium point before setting its stress state.

2. Symmetric boundary conditions.

The (1,3) and (2,3) planes were modeled as planes of symmetry. So that in effect a full 360° model was constructed. See figure 1.

3. Impose continuous cylindrical shell boundary conditions.

on the up stream shell the rotations were removed and all translational degrees of freedom were left in the model. By removing the rotations, moments were generated to simulate a continuous cylindrical shell.

The down stream shell had the same boundary conditions, with the exception of the rods being attached to these points.

Note: Rod elements are not capable of transmitting bending moments. So all bending moments had to be taken out by the shell elements. See figure 2.

all other degrees of freedom were left in the model.

The model had 2009 nodes or, after imposing all the boundary conditions, a little less than 12,000 degrees of freedom.

Model geometry

As previously mentioned a quarter model, with forty elements around the circumference and zong holes, was generated.

all elements were membrane and bending flat plates.

Approximately six feet, of cylindrical shell was modeled on either side of the bulkhead/shell intersection. a detailed sketch of this intersection is shown in figure 3. The extra metal around the 3" radius from a modeling standpoint is rather difficult to model. Therefore, this section was modeled as shown in figure 4.

leaving out this extra stiffness, by not connecting say points A and B (see figure 4), with elements that would exhibit the same stiffness; no unusually high stresses were found to exist.

**ORIGINAL PAGE IS
OF POOR QUALITY**

BY _____ DATE _____

SUBJECT _____

SHEET NO. B OF _____

CHKD. BY _____ DATE _____

JOB NO. _____

Modeling of the extra shell lengths served to main purposes:

First the bulkhead / shell intersection effect on the shell had to be determined.

It was found that this discontinuity had no adverse effect on the shell, and tends to die out very quickly.

Second, a check point on the model had to be built-in so that one might conclude that the appropriate loads and boundary conditions had been imposed. Stresses on the shell boundaries showed that little or no bending was taking place and hand calculations could predict stresses in these regions.

ORIGINAL PAGE IS
OF POOR QUALITY

BY _____ DATE _____ SUBJECT _____
CHKD. BY _____ DATE _____

SHEET NO. 9 OF _____
JOB NO. _____

The gussets on the bulkhead flange were modeled as plate elements connecting the flange to the bulkhead. See figure 4.

The support ring set was modeled with plate elements and stem of the ring connected directly into the shell at point C. (See figure 4.)

ORIGINAL PAGE IS
OF POOR QUALITY

The joint numbering sequence started at the top of the flange surface, at theta equal 0° increased in the theta direction first, then along the meridian. The joint numbering sequences are shown in figures 21 thru 25.

The shell section properties (plate thickness) were modeled as indicated in figure 1. Tapers were modeled as an average of the two adjacent thicknesses.

Section properties are shown in figures 26 thru 32.

Section property numbers and their corresponding thickness are listed below.

Sect. No.	Thickness	Sect. No.	Thickness
1	4.00	10	1.25
2	5.25	11	3.00
3	4.00	12	4.00
4	4.00	13	1.50
5	4.00	14	3.00
6	4.00	15	2.50
7	3.00	16	3.00
8	1.30	17	2.15
9	3.00		

ORIGINAL PAGE IS
OF POOR QUALITY

Material Properties used in this analysis are listed below.

304 stainless Steel

ρ	.283 lb/in ³	density
α	$.730 \times 10^{-5} \frac{\text{IN}}{\text{IN}^2}$	Coef. of Ther. exp.
E	28. x 10 ⁶ psi	Mod. of elast.
γ	.3	Poisson's ratio.

Table 17. Selected Thermal Properties of Some Steels
(See also Tables 5A and 5B, Page 12)

<p>3½% Nickel Steel</p> <p>Thermal Expansion Coefficient 0 to +200°F</p> <p>Thermal Conductivity -150°F (mean) +68°F (mean) +200°F (mean)</p> <p>Specific Heat -150 to +80°F +80 to +1000°F</p>	<p>6.15 x 10⁻⁶ in./in./°F</p> <p>214 Btu/in./hr./ft²/°F 253 Btu/in./hr./ft²/°F 270 Btu/in./hr./ft²/°F</p> <p>0.798 Btu/lb./°F 0.147 Btu/lb./°F</p>
<p>9% Nickel Steel</p> <p>Thermal Expansion Coefficient At room temperature -300 to 0°F (avg.) -300 to +200°F (avg.) at -300°F</p> <p>Thermal Conductivity -320°F -150°F +68°F +200°F</p> <p>Specific Heat -320 to +80°F +80 to +700°F</p>	<p>5.8 x 10⁻⁶ in./in./°F 5.3 x 10⁻⁶ in./in./°F 5.6 x 10⁻⁶ in./in./°F 4.0 x 10⁻⁶ in./in./°F</p> <p>91.3 Btu/in./hr./ft²/°F 169.0 Btu/in./hr./ft²/°F 189.0 Btu/in./hr./ft²/°F 209.0 Btu/in./hr./ft²/°F</p> <p>0.0878 Btu/lb./°F (avg.) 0.119 Btu/lb./°F (avg.)</p>
<p>304 Stainless Steel</p> <p>Thermal Expansion Coefficient +32 to +212°F -300 to +70°F (mean) +70 to +1000°F (mean) at -300°F</p> <p>Thermal Conductivity -320°F -155°F +70°F +600°F</p> <p>Specific Heat -320°F -150°F +80°F</p>	<p>9.6 x 10⁻⁶ in./in./°F 7.3 x 10⁻⁶ in./in./°F 10.0 x 10⁻⁶ in./in./°F 5.9 x 10⁻⁶ in./in./°F</p> <p>56.4 Btu/in./hr./ft²/°F 90.0 Btu/in./hr./ft²/°F 113.0 Btu/in./hr./ft²/°F 120.0 Btu/in./hr./ft²/°F</p> <p>0.037 Btu/lb./°F (avg.) 0.088 Btu/lb./°F (avg.) 0.120 Btu/lb./°F (avg.)</p>

U.S. Steel "Low Temperature and Cryogenic Steels"
Materials Manual Feb. 1967 Second Revised Printing

ORIGINAL PAGE IS
OF POOR QUALITY

Loadings

The following loading cases were run.

Case 1. Gate Valve Closed

Case 2. Gate Valve open

Case 3. Full pressure

Case 4. Gate Valve open w/ steady
state temperature distribution

Case 5. Gate Valve closed w/ transient
temperature distribution.

To aid in explaining the different loading configuration refer to figures 2 and 5.

- P₁ is a nodal pressure applied to all nodes on the up stream shell and bulk head.
- P₂ is a nodal pressure applied to all nodes on the down stream shell and bulk head.
- P₃ is a nodal pressure applied to all nodes on the up stream and down stream shell.
- LG is a nodal force applied to each node around the circumference, except for the nodes on the $\theta = 0^\circ$ and 90° axis here the magnitude of LG is $1/2$. This load is due to the sealing force generated by the gate valve, and/or dog pre loads
- LD is a nodal force applied in pairs of nodes at dog locations. These loads are spring preloads or reaction to aerodynamic loads.
- LS is a nodal force:
 1. applied in pairs of nodes at dog locations, for valve closed cond.
 2. applied to each node around the circumference, except for nodes at $\theta = 0^\circ 90^\circ$, here the magnitude is $1/2$.

for valve open conditions.

LTF is a nodal force applied in pairs of nodes at dog locations. These loads are spring preloads

M is a nodal moment applied to each node around the circumference, except for nodes located on the $\theta = 0^\circ$ and 90° axis, here the magnitude is $1/2$. This moment is a result of an assumed misalignment of components

F is a nodal force applied to each node around the circumference, except for nodes located on the $\theta = 0^\circ$ and $\theta = 90^\circ$ axis, here the magnitude is $1/2$.

This is a boundary load due to capping off the end of the cylinder.

BY _____ DATE _____

SUBJECT _____

SHEET NO. 16 OF _____

CHKD. BY _____ DATE _____

JOB NO. _____

Case 1. Gate Valve Closed

For this loading configuration
The following loads were applied.

$$P_1 = 119.0 \text{ PSIA}$$

$$P_2 = 0.0 \text{ PSIA}$$

$$P_3 = 0.0 \text{ PSIA}$$

$$L_G = -17483.0 \text{ lbs}$$

$$L_S = 19500.0 \text{ lbs}$$

$$L_{TF} = -19500.0 \text{ lbs}$$

$$F = 66242.0 \text{ lbs}$$

$$L_D = 0.0 \text{ lbs}$$

$$M = 0.0 \text{ IN-lbs}$$

BY _____ DATE _____
CHKD. BY _____ DATE _____

SUBJECT _____

SHEET NO. 17 OF _____
JOB NO. _____

Case 2. Gate Valve open / running cond.

For this loading configuration
The following loads were applied:

$$P_1 = 133.7 \text{ PSIA}$$

$$P_2 = 53.4 \text{ PSIA}$$

$$P_3 = 14.7 \text{ PSIA}$$

actual down stream shell
pressure 57.6 PSIG.

$$LD = 13000. \text{ lbs.}$$

$$LG = -5568.8 \text{ lbs.}$$

$$LS = 3018.8 \text{ lbs.}$$

$$LTF = -19500. \text{ lbs.}$$

$$M = 145275. \text{ IN-lbs}$$

$$F = 66242.0 \text{ lbs}$$

BY _____ DATE _____

SUBJECT _____

SHEET NO. 18 OF _____

CHKD. BY _____ DATE _____

JOB NO. _____

Case 3. Full pressure

For this loading configuration the following loads were applied.

$P_1 = 119.0$ PSIA
 $P_2 = 119.0$ PSIA
 $P_3 = 0.0$ PSIA
 $F = 66242.0$ lbs
 $HG = 0.$ lbs
 $LD = 0.$ lbs
 $LTF = 0.$ lbs
 $LS = 0.$ lbs
 $M = 0.$ IN-lbs

This loading case was run primarily for superposition of shell stresses on a S4 and S5 a symmetric ring load analysis.

Case 4 Gate Valve open w/ steady state temperature distribution

For this loading configuration the following loads were applied:

$$P_1 = 133.7 \text{ PSIA}$$

$$P_2 = 53.4 \text{ PSIA}$$

$$P_3 = 14.7 \text{ PSIA}$$

actual down stream shell pressure 57.6 psig.

$$LD = 13000. \text{ lbs}$$

$$LG = -5568.8 \text{ lbs}$$

$$LS = 3018.8 \text{ lbs}$$

$$LTF = -19500. \text{ lbs}$$

$$M = 145275. \text{ in-lbs}$$

$$F = 66242. \text{ lbs}$$

And the temperature distribution shown in figure 7a was applied. This temperature distribution was uniform through the element thickness and around the circumference of the model.

Case 5 Gate Valve closed w/
Transient temperature distribution

For this loading configuration the following loads were applied.

$$P_1 = 119. \text{ PSIA}$$

$$P_2 = 0.0 \text{ PSIA}$$

$$P_3 = 0.0 \text{ PSIA}$$

$$L_G = -17483.0 \text{ lbs}$$

$$L_{TF} = -19500.0 \text{ lbs}$$

$$L_S = 19500.0 \text{ lbs}$$

$$F = 66242.6 \text{ lbs}$$

$$L_D = 0.0 \text{ lbs}$$

$$M = 0.0 \text{ lbs}$$

ORIGINAL PAGE IS
OF POOR QUALITY

and the temperature distribution shown in figure 7b. was applied. This temperature distribution was uniform through the element thickness and around the circumference of the model.

Stress and deflection results

Presented with the summary results for the following cases are computer stress plots, where the circumferential (s_x) or meridian (s_y) nodal stresses are given for, mid-surface (surface 0), inside surface (surface 1), and outside surface (surface 2).

The stresses are plotted for joint one of the element (reference figure 6 and 18). For the element defined by the joints 1 2 43 42, joint one for that element is node 1.

Nodal stresses for a joint are given from the four surrounding elements. If any discrepancies exist in the stresses for a joint due to discontinuities in the structure (ie. rings, cone cyl. junct.) The larger value is used in the interpretation of the results.

BY _____ DATE _____

SUBJECT _____

SHEET NO. 25 OF _____

CHKD. BY _____ DATE _____

JOB NO. _____

Results load case 1

Ualve Closed

BY _____ DATE _____

SUBJECT _____

SHEET NO. 23 OF _____

CHKD. BY _____ DATE _____

JOB NO. _____

The following table is a list of
The max. and min. principle
stresses at the joints indicated.
also, in the table is the max. bending
stress at these node and the
surface they occur on.

Surface A = inside surface.

Surface B = outside surface.

BY _____ DATE _____ SUBJECT _____
 CHKD. BY _____ DATE _____
 LAIK _____

SHEET NO. 24 OF _____
 JOB NO. _____

NODE See Fig 6	Max Ps Membrane	MIN Ps Membrane	Bending / surface
1	-0.69	-3.77	-4.71/B
83	-0.80	-3.72	-4.73/B
124	-0.68	-4.30	-4.75/A
206	-0.03	-6.85	-6.90/A
288	-1.55	-7.27	-7.49/A
329	-2.52	-6.32	-7.70/A
370	-3.40	-7.67	-11.73/A
411	-3.12	-7.46	-12.42/B
452	-3.42	-6.89	-8.23/B
493	-3.53	-5.60	-6.27/B
534	-3.59	-4.92	-5.57/B
575	-3.62	-4.47	-5.18/B
616	-3.43	-3.60	-5.34/B
657	-2.10	-3.51	-5.96/B
698	.00	-3.35	-5.72/B
739	1.70	-3.10	-3.91/B
780	4.16	-2.90	-8.69/A
821	4.86	-2.81	-11.42/A
862	5.10	-2.71	-11.42/A
903	4.91	-2.61	-9.71/A
944	6.16	3.33	6.17/A
985	7.01	3.33	7.16/B
1190	15.71	7.69	15.79/A
1272	4.67	-.08	5.82/B
1559	4.12	-.08	AA/B
1641	2.38	-.10	-
1805	-.29	-.13	-
1887	-.05	-.13	-
247	-1.03	-7.52	-7.68/B

BY..... DATE..... SUBJECT.....

SHEET NO. 25 OF.....

CHKD. BY..... DATE.....

JOB NO.

Shown in figures 33 thru 59
are stress plots for this
loading case.

The stresses shown are not
principle stresses however, due
to the symmetry in the geometry
and loads there is very little
transverse shear. Thus, these
stress values could be treated
as principle stresses

BY _____ DATE _____

SUBJECT _____

SHEET NO. 26 OF _____

CHKD. BY _____ DATE _____

JOB NO. _____

Membrane Stress (intensity)

Primary local membrane stress intensity
(Node 370)

$$\sigma_1 = -3.40 \text{ KSI}$$

$$\sigma_2 = -7.67 \text{ KSI}$$

$$\sigma_3 = -.06 \text{ KSI}$$

$$s_{12} = -3.40 - (-7.67) = 4.27 \text{ KSI}$$

$$s_{23} = -7.67 - (-.06) = -7.61 \text{ KSI}$$

$$s_{31} = -.06 - (-3.40) = 3.34 \text{ KSI}$$

$$s = |-7.61| = 7.61$$

$$P_m = 7.61 < 20.0 \text{ KSI} \quad \text{OK}$$

Since the stress intensity is $< S_m$ (20KSI)
the stress intensity meets the criteria
for general membrane stress intensity.

General membrane stress

$$s = 15.71 \text{ KSI} \quad (\text{Shell node 1150})$$

$$15.71 < 18.2 \text{ KSI} \quad \text{OK}$$

This region meets the stress
evaluation criteria for general
membrane stress.

ORIGINAL PAGE IS
OF POOR QUALITY

BY..... DATE.....

SUBJECT.....

SHEET NO. 27 OF.....

CHKD. BY..... DATE.....

.....

JOB NO.

Primary plus Secondary stress intensity
(Node 446)

inside surface

$$\sigma_1 = -4.93 \text{ KSI}$$

$$\sigma_2 = -11.73 \text{ KSI}$$

$$\sigma_3 = -.119 \text{ KSI}$$

$$s_{1,2} = -4.93 - (-11.73) = 6.8 \text{ KSI}$$

$$s_{2,3} = -11.73 - (-.119) = -11.61 \text{ KSI}$$

$$s_{3,1} = -.119 - (-4.93) = 4.81 \text{ KSI}$$

$$s = |-11.61| = 11.61 \text{ KSI}$$

$$P_L + P_B + Q < 3 S_m$$

$$11.61 < 3 S_m = 60 \text{ KSI OK}$$

BY _____ DATE _____ SUBJECT _____
CHKD. BY _____ DATE _____

SHEET NO. 28 OF _____
JOB NO. _____

Outside side surface
(Node 411)

$$\sigma_1 = -12.83 \text{ KSI}$$

$$\sigma_2 = -13.44 \text{ KSI}$$

$$\sigma_3 = 0 \text{ KSI}$$

$$S_{12} = -12.83 - (-13.44) = .61 \text{ KSI}$$

$$S_{23} = -13.44 - 0 = -13.44 \text{ KSI}$$

$$S_{31} = 0 - (-12.83) = 12.83 \text{ KSI}$$

$$S = |-13.44| = 13.44 \text{ KSI}$$

$$P_L + P_0 + 0 < 3 S_m$$

$$13.44 < 60 \text{ KSI} \quad \text{OK}$$

The primary plus secondary
stress intensity meets the stress
evaluation criteria.

BY _____ DATE _____ SUBJECT _____

SHEET NO. 29 OF _____

CHKD. BY _____ DATE _____

JOB NO. _____

The following sketch and table
shows the relative displacement
and indicates the rotation of
the sealing surface

**ORIGINAL PAGE IS
OF POOR QUALITY**

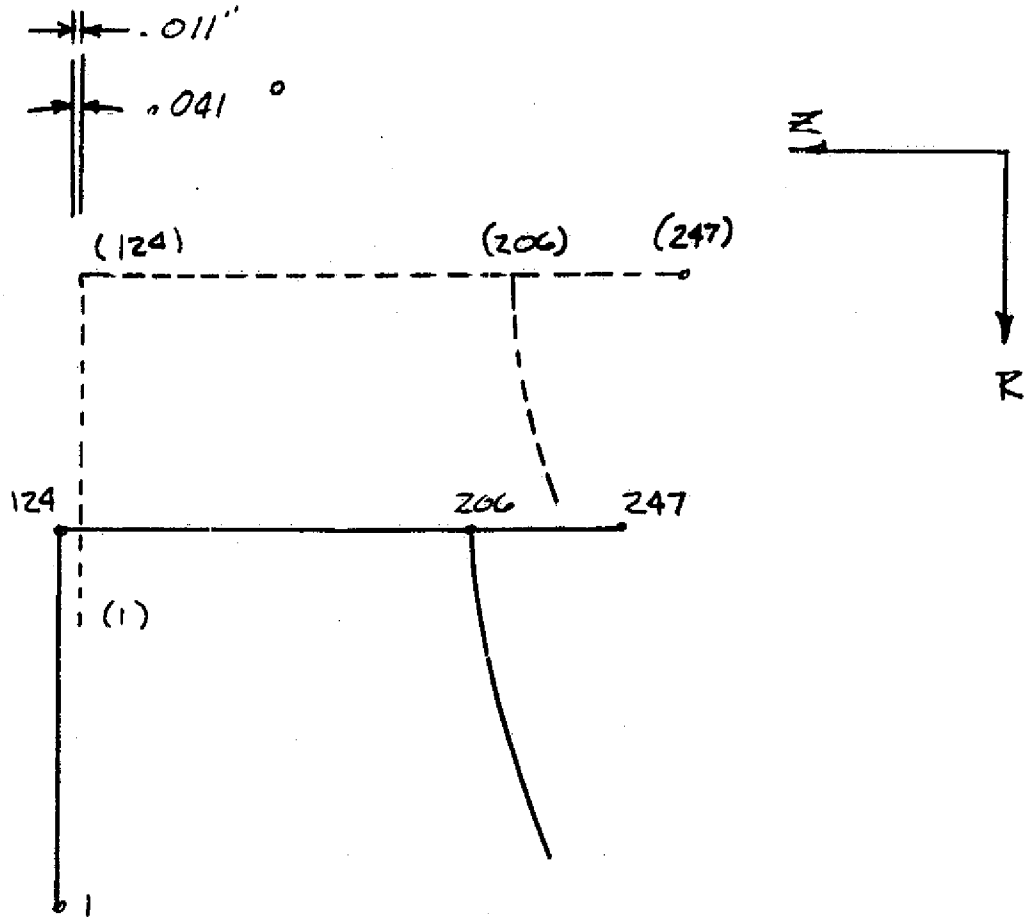

Displacements

Joint	ΔR IN.	ΔZ IN.
1	-.012	-.0907
124	-.012	-.0797
206	-.0198	-.0800
247	-.0228	-.0803

BY _____ DATE _____

SUBJECT _____

SHEET NO. 31 OF _____

CHKD. BY _____ DATE _____

JOB NO. _____

Results Load Case 2

Valve open / running condition

Due to the decreased pressure differential across the bulkhead (76.3 psig) and the downstream pressure being far less than design (57.6 psig vs. 119.0 psig design). Stresses were as expected very low and further analysis of this loading condition was not warranted.

Stresses for this loading condition:

Upstream and downstream shell,

Here, the stresses are equal to those generated from Case 1 (see fig 60 thru 86 and compare to 33 fig 59 thru)
∴, this region meets the stress evaluation criteria.

Bulkhead,

Here the stress are less than those generated from Case 1.

∴, this region meets the stress evaluation criteria for this loading condition

Results load case 3

Full Pressure

Below is a sketch of the stress picture used on a S4 and S5 asymmetric ring load analysis.

Refer to section "S4 and S5 ring analysis" for composite analysis of this support ring region.

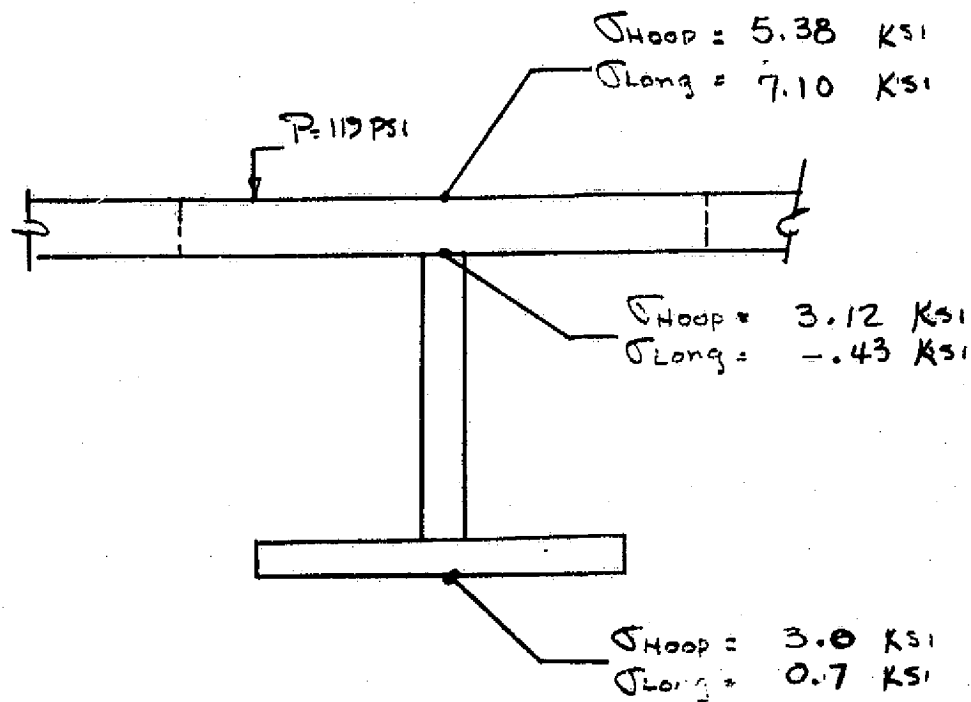

S4 or S5

figures 87 thru 113 show the general stress picture of the model during this loading condition.

BY _____ DATE _____

SUBJECT _____

SHEET NO. 34 OF _____

CHKD. BY _____ DATE _____

JOB NO. _____

Results load Case 4

Gate Valve open / running condition
w/ temperature distribution

(Steady State)

BY _____ DATE _____

SUBJECT _____

SHEET NO. 35 OF _____

CHKD. BY _____ DATE _____

JOB NO. _____

The following table is a list of
The max. and min. principle
stresses at the joints indicated.
also, in the table is the max.
principle bending stress at the
nodes and the surface they
occur on.

Surface A = inside surface

Surface B = outside surface

BY _____ DATE _____ SUBJECT _____
 CHKD. BY _____ DATE _____
 LAD _____

SHEET NO. 36 OF _____
 JOB NO. _____

Node See Fig 6	Max Ps Membrane	Min Ps Membrane	Bending / surface
1	-.14	-1.60	-2.78 / A
83	-.21	-.70	-2.39 / A
124	.47	.22	5.33 / A
206	-.15	-3.27	-3.35 / A
288	.30	-4.50	-5.59 / A
329	1.45	-4.75	-5.60 / A
370	-2.04	-5.32	-9.45 / A
411	-1.18	-7.00	-13.05 / B
452	-1.76	-6.18	-9.70 / B
493	-1.88	-4.90	-10.09 / B
534	-1.96	-3.46	-10.98 / B
575	-1.95	-1.95	-11.56 / B
616	-0.54	-1.89	-12.49 / B
657	-0.18	-1.77	-12.54 / B
698	2.41	-1.62	-10.55 / B
739	-1.48	-1.59	-7.25 / B
780	11.80	-1.21	13.05 / A
821	4.13	-1.24	-9.98 / A
862	9.98	-1.28	-15.54 / A
903	14.91	-1.39	20.76 / B
944	3.33	3.31	42.20 / B
985	3.33	-4.27	27.93 / B
1190	18.45	7.69	18.57 / B
1272	1.36	1.11	10.67 / B
1559	2.68	1.36	11.10 / B
1641	6.09	1.63	9.31 / B
1805	6.04	2.04	6.20 / A
1887	4.66	2.04	4.67 / B
247	-.15	-4.60	-4.74 / A

Shown in figures 114 thru 140 are stress plots for this loading case.

The stresses shown are not principle stresses. However, due to the symmetry in the geometry and loads there is very little to no transverse shear.

thus, these stress values could be treated as principle stresses.

Membrane stress (intensity)
 Primary local stress intensity
 (Node 903)

$\sigma_1 = 14.91 \text{ KSI}$

$\sigma_2 = -1.39 \text{ KSI}$

$\sigma_3 = -.06 \text{ KSI}$

$S_{12} = 14.91 - (-1.39) = 16.3 \text{ KSI}$

$S_{23} = -1.39 - (-.06) = -1.33 \text{ KSI}$

$S_{31} = (-.06) - (+14.91) = -14.97 \text{ KSI}$

ORIGINAL PAGE IS
 OF POOR QUALITY

$\sigma = 1/6.3 = 16.3 \text{ KSI}$

$P_m: 16.3 \text{ KSI} < 20.0 \text{ KSI} \text{ OK}$

Since the stress intensity is $< S_m (20.0)$
 The stress intensity meets the criteria
 for general membrane stress intensity.

General Membrane stress

$S = 18.45 \text{ KSI} \quad (\text{shell node 1190})$

$18.45 < S_m \text{ KSI} \text{ OK}$

this region meets the stress
 evaluation criteria for general
 membrane stress

BY _____ DATE _____
CHKD. BY _____ DATE _____

SUBJECT _____

SHEET NO. 39 OF _____
JOB NO. _____

Primary plus Secondary
stress intensity
(node 944)

Inside surface

$$\sigma_1 = -8.36 \text{ KSI}$$

$$\sigma_2 = -35.54 \text{ KSI}$$

$$\sigma_3 = -.119 \text{ KSI}$$

$$S_{12} = -8.36 - (-35.54) = 27.18 \text{ KSI}$$

$$S_{23} = -35.54 - (-.119) = -35.421 \text{ KSI}$$

$$S_{31} = -.119 - (-8.36) = 8.241 \text{ KSI}$$

$$S = |-35.421| \text{ KSI} = 35.421 \text{ KSI}$$

$$P_r + P_s + Q < 3S_m$$

$$35.421 < 3S_m = 60 \text{ KSI} \quad \text{OK}$$

BY _____ DATE _____
CHKD. BY _____ DATE _____

SUBJECT _____

SHEET NO. 40 OF _____
JOB NO. _____

Out side surface stress
(node 944)

$$\sigma_1 = 42.2 \text{ ksi}$$

$$\sigma_2 = 14.97 \text{ ksi}$$

$$\sigma_3 = 0 \text{ ksi}$$

$$S_{12} = 42.2 - 14.97 = 27.23 \text{ ksi}$$

$$S_{23} = 14.97 - 0 = 14.97 \text{ ksi}$$

$$S_{31} = 0 - 42.2 = -42.2 \text{ ksi}$$

$$S = |-42.2| = 42.2 \text{ ksi}$$

$$P_1 + P_2 + Q < 3S_m = 60 \text{ ksi}$$

$$42.2 < 60 \text{ ksi} \quad \text{ok}$$

The primary plus secondary stress intensity meets the stress evaluation criteria.

BY _____ DATE _____

SUBJECT _____

SHEET NO. 41 OF _____

CHKD. BY _____ DATE _____

JOB NO. _____

Results load case 5

Value Closed w/ transient temp. dist.

BY _____ DATE _____

SUBJECT _____

SHEET NO. 46 OF _____

CHKD. BY _____ DATE _____

JOB NO. _____

Shown in figures 141 thru 167
are stress plots for
this loading case.

The stresses shown are
not principle stresses

however, due to the symmetry
in geometry and loads there
is very little transverse shear

Thus, these stress values could
be treated as principle
stresses.

BY..... DATE.....

SUBJECT.....

SHEET NO. 43 OF.....

CHKD. BY..... DATE.....

JOB NO.....

The following table is a list of Max. and MIN principle stresses at the joints indicated.

also, in the table is the max. principle bending stress at the node and the surface the accurate on.

Surface A = inside surface

Surface B = outside surface

BY _____ DATE _____ SUBJECT _____
 CHKD. BY _____ DATE _____
 AAK _____

SHEET NO. 44 OF _____
 JOB NO. _____

Node See Fig 6	Max Ps Membrane	Min Ps Membrane	Bending / surface
1	19.89	2.66	27.41 / A
83	20.80	-1.91	22.52 / A
124	11.84	-2.61	15.11 / A
206	-0.06 -7.51	-57.89 -59.79	-59.47 / A -61.76 / A
288	3.58	-7.69	-9.49 / B
329	3.13	-8.81	-10.80 / B
370	.92	-5.52	-10.50 / B
411	6.63	-3.84	13.38 / A
452	1.71	-4.17	11.06 / B
493	-.51	-3.82	-15.25 / B
534	-1.22	-3.77	-16.43 / B
575	-.87	-3.67	-16.88 / B
616	-2.04	-3.59	-17.45 / B
657	-3.43	-3.52	-17.62 / B
698	-3.43	-3.52	-17.62 / B
739	5.15	-2.89	-14.66 / B
780	12.55	-2.45	15.12 / A
821	19.54	-2.29	19.97 / B
862	20.58	-2.30	24.02 / B
903	12.56	-2.30	-25.02 / A
944	3.33	2.86	45.00 / B
985	3.33	-4.89	29.13 / A
1190	16.00	8.00	16.00 / A
1272	4.00	.0	
1559	4.0	.0	
1641	3.0	.0	
1805	1.0	.0	
1887	0	0	
247	-.06	-61.76	-61.81 / A -61.71 / B

Membrane Stress (Intensity)
primary local stress intensity

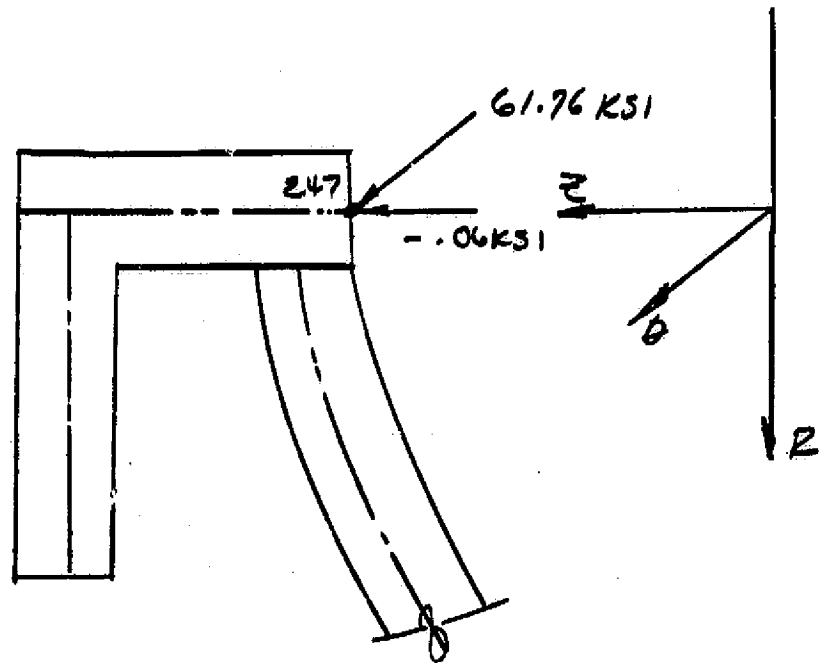

$$\begin{aligned}\sigma_1 &= -0.06 \text{ KSI} \\ \sigma_2 &= -61.76 \text{ KSI} \\ \sigma_3 &= 0 \text{ KSI} \\ S_{12} &= -0.06 - (-61.76) = +61.70 \text{ KSI} \\ S_{23} &= -61.76 - 0 = -61.76 \text{ KSI} \\ S_{31} &= 0 - (-0.06) = 0.06 \text{ KSI} \\ &= | -61.76 | = 61.76 \text{ KSI}\end{aligned}$$

BY _____ DATE _____

SUBJECT _____

SHEET NO. 46 OF _____

CHKD. BY _____ DATE _____

JOB NO. _____

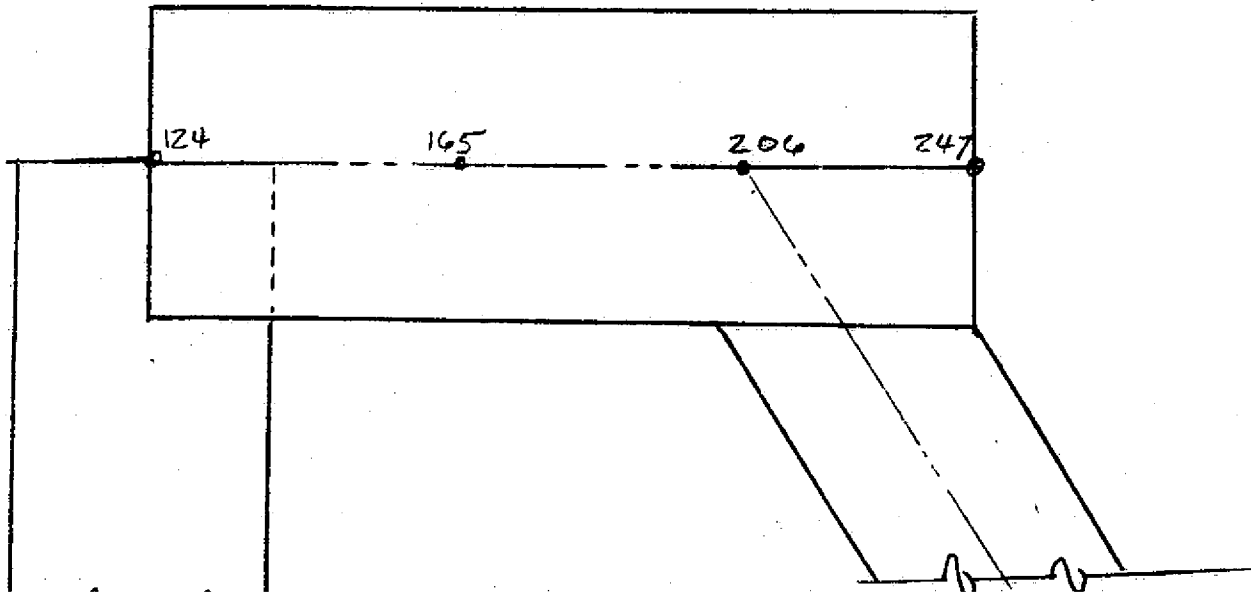
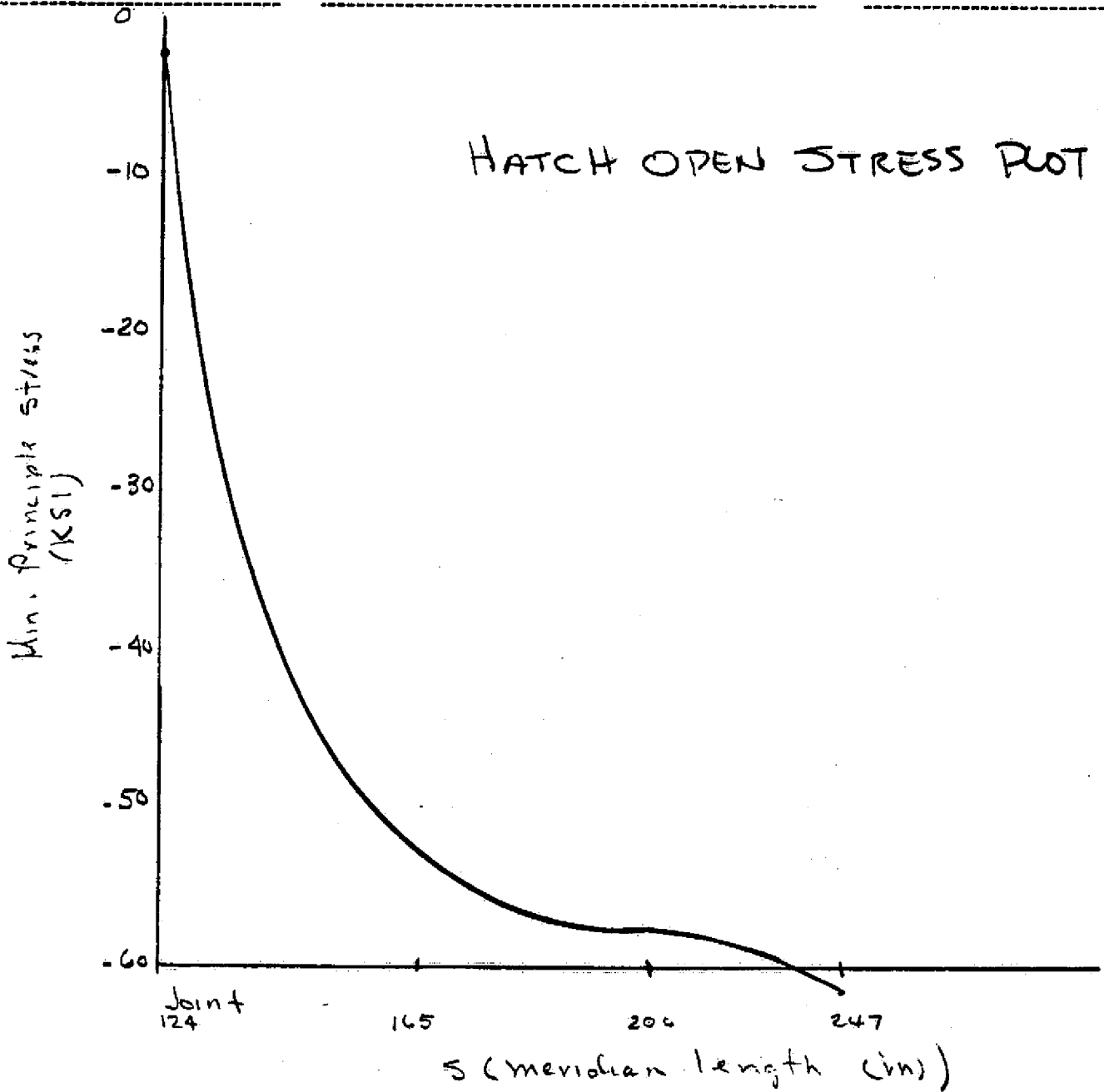

SHAKEDOWN ANALYSIS

FOR HATCH OPENING AREA.

$$P_b + P_m + Q - \text{Thermal} \leq 3S_m$$

from Case 1

$$P_b + P_m + Q \leq 7.58 \text{ KSI} \leq 3S_m \quad \text{OK}$$

$$S_m = 30 \text{ KSI}$$

$$S_n = 62.0 \text{ KSI}$$

$$K_c = 1.0 + \frac{(1-\gamma)}{\gamma(m-1)} \left(\frac{S_n}{3S_m} - 1 \right)$$

for $3S_m < S_n < 3mS_n$

$$m = 1.7, \gamma = .3$$

$$60 < 62 < (3)(1.7)(62) = 316.2 \text{ KSI}$$

$$K_c = 1.0 + \frac{(.7)}{.3(.7)} \left(\frac{62}{60} - 1 \right) = 1.111$$

THERMAL RATCHET IN SHELL

$$Y' = \frac{S_T}{S_y}$$

$$X = \frac{|-7.56|}{S_y} = .252$$

$$S_y = 30 \text{ KSI}$$

LINEAR VARIATION OF TEMPERATURE THROUGH THE SHELL WALL (CONSTANT)

$$Y' = \frac{1}{x} \text{ for } 0 < x < .5$$

$$Y' = \frac{1}{.252} = 3.964$$

$$S_T = Y' S_y = (3.964)(30) = 118.9 \text{ KSI}$$

$$\therefore P_L + P_B + Q < S_T$$

$$P_L + P_B + Q = 61.76 \text{ KSI} < S_T = 118.9 \text{ KSI}$$

WITH NEW K_c factor $K_c = 1.11$ OK

THE TEMPERATURE DOES NOT EXCEED:

- 320°F < TEMPERATURE < 200

AND,

$$\frac{S_y}{S_{ULT}} = \frac{30}{75} = .4 < .8$$

Membrane stress (intensity)
 (away from hatch opening)

Primary local Membrane stress intensity
 (Node 862)

$$\sigma_1 = 20.58 \text{ KSI}$$

$$\sigma_2 = -2.30 \text{ KSI}$$

$$\sigma_3 = -.06 \text{ KSI}$$

$$S_{12} = 20.58 - (-2.30) = 22.88 \text{ KSI}$$

$$S_{23} = -2.30 - (-.06) = -2.24 \text{ KSI}$$

$$S_{31} = -.06 - 20.58 = -20.64 \text{ KSI}$$

$$S = |22.88| = 22.88 \text{ KSI}$$

$$P_u = 22.88 < 30.0 \text{ KSI} \quad \text{OK}$$

ORIGINAL PAGE IS
 OF POOR QUALITY

Since the stress intensity is $< S_m$ (30.0 KSI)

The stress intensity meets the criteria
 for general membrane stress intensity.

GENERAL Membrane stress

$$S = 16.00 \text{ KSI} < S$$

$$16.00 < 18.2 \text{ KSI} \quad \text{OK}$$

(Shell, Node 1190)

This region meets the stress evaluation
 criteria for general membrane stress

BY _____ DATE _____

SUBJECT _____

SHEET NO. 50 OF _____

CHKD. BY _____ DATE _____

JOB NO. _____

PRIMARY PLUS SECONDARY

STRESS INTENSITY

(NODE 944)

INSIDE SURFACE

$$\sigma_1 = 45.0 \text{ KSI}$$

$$\sigma_2 = 15.0 \text{ KSI}$$

$$\sigma_3 = -0.119 \text{ KSI}$$

$$S_{12} = 45 - 15 = 30 \text{ KSI}$$

$$S_{23} = 15 - (-0.119) = 15.119 \text{ KSI}$$

$$S_{31} = -0.119 - 45 = -45.119$$

$$S = |-45.119| = 45.119 \text{ KSI}$$

$$P_c + P_b + Q < 3S_m$$

$$45.119 \text{ KSI} < 60 \text{ KSI} \quad \text{OK}$$

BY _____ DATE _____

SUBJECT _____

SHEET NO. 51 OF _____

CHKD. BY _____ DATE _____

JOB NO. _____

OUTSIDE SURFACE STRESS
(NODE 944)

$$\sigma_1 = 38.0 \text{ KSI}$$

$$\sigma_2 = -10.0 \text{ KSI}$$

$$\sigma_3 = 0 \text{ KSI}$$

$$s_{12} = 38 - (-10) = 48 \text{ KSI}$$

$$s_{23} = -10 - 0 = -10 \text{ KSI}$$

$$s_{31} = 0 - 38 = -38 \text{ KSI}$$

$$s = |48| = 48.0 \text{ KSI}$$

$$P_c + P_D + Q < 3S_m$$

$$48.0 < 60 \text{ KSI} \quad \text{OK}$$

THE PRIMARY PLUS SECONDARY
STRESS INTENSITY MEETS THE
STRESS EVALUATION CRITERIA.

THE TRANSIENT TEMPERATURE DISTRIBUTION SHOWN IN FIGURE 7b WAS A RESULT OF THE UPSTREAM GAS REMAINING AT -300°F, AND THE PLENUM GAS MAINTAINING 100°F.

THE POSSIBILITY OF THIS CONDITION EXISTING IS VERY REMOTE.

FIRST, HEATERS WOULD HAVE TO BE EMPLOYED TO MAINTAIN THE 100°F IN THE PLENUM AREA.

SECOND THE UPSTREAM GAS CAN NOT BE MAINTAINED AT -300°F WITH OUT SOME HEAT TRANSFER THROUGH THE INSULATION.

THE 62.KSI PEAK THERMAL STRESS
ALTHOUGH, ALLOWED BY A SHAKE DOWN
ANALYSIS, WILL PROBABLY NEVER
ACCURE. HOWEVER, THE WARM
UP CYCLE FOR THE PLENUM SHOULD
PRECLUDE ANY WARM UP TIME
LESS THAN 30 MIN.

THIS ANALYSIS WAS ALSO,
RUN ON A BETTER COMPUTER
CODE - SRA, TO VERIFY THESE
RESULTS.

SEE CASE 2 UNDER SRA
COMPUTER ANALYSIS, OF
BULK HEAD REGION.

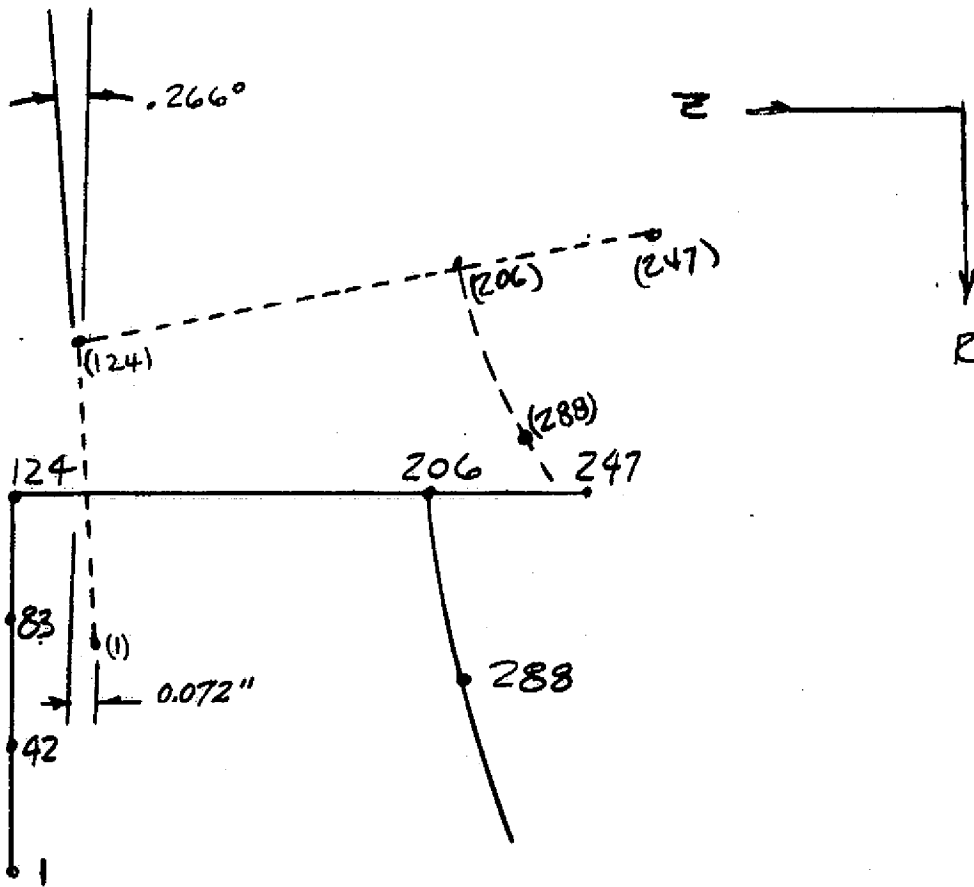

Displacements

Joint	ΔR IN.	ΔZ IN.
1	-0.120	-0.367
124	-0.0884	-0.295
206	-0.123	-0.299
247	-0.135	-0.303
288	-0.130	-0.310
42	-0.108	-0.341
83	-0.0991	-0.321

SRA model description

SRA was used to compute a linear and a non-linear stress and displacement response under symmetric loads.

The structure was assumed to be an axisymmetric structure.

See figure 8 for a computer plot of the meridional surface.

also, shown on the plot is the right-handed triad (S, θ, Z) used in defining:

- a. rigid body constraints
- b. Model geometry
- c. direction of all discrete loads
- d. location of all bifurcation points

ORIGINAL PAGE IS
OF POOR QUALITY

BY _____ DATE _____

SUBJECT _____

SHEET NO. 56 OF _____

CHKD. BY _____ DATE _____

JOB NO. _____

rigid body constraints

Boundary conditions were imposed as shown in figure 8.

on the upstream shell the axial displacement as well as rotations were taken out. This forced the model to generate it's own axial forces when pressure applied across the bulkhead.

on the downstream shell only the rotations were taken out.

Model geometry

As previously stated the structure was axisymmetric with the exception of the bulkhead flange gussets.

These gussets were modeled as stringers - where their additional stiffness was smeared along both the backside of the flange and bulkhead in the areas of their actual location.

The model was constructed with 31 subsections (the "+" marks on figures 8 thru 11) with stress recovery points at the beginning, middle and end of each subsection.

The subsection or fictitious boundaries were inserted to:

- a. limit the subinterval length
($\Delta L < \sqrt{rE}$)
- b. locate rings (indicated on figure 8 by an "O")
- c. points of discrete loads.
- d. locate a branch point in the shell.

BY _____ DATE _____
CHKD. BY _____ DATE _____

SUBJECT _____

SHEET NO. 58 OF _____
JOB NO. _____

The bulkhead insulation rings were included in this model. They were input as discrete ring properties at the ring's centroid located relative to the shells surface.

all taper thickness were modeled as tapers.

See figure 9 which is a computer profile plot with the various section thickness noted.

ORIGINAL PAGE IS
OF POOR QUALITY

Loadings

The following cases were run:

Case 1. Gate Valve Closed

Case 2. Gate Valve Closed

W/ Transient temperature distribution.
30 min. WARM UP. TIME

CASE 3. Gate Valve Closed

W/ TRANSIENT TEMPERATURE
DISTRIBUTION.

4 HOUR WARM UP TIME

ORIGINAL PAGE IS
OF POOR QUALITY

Case 1 Gate Valve Closed

For this loading configuration
the following loads were
applied to the model: (see fig 11)

$$P_1 = 119 \text{ psia}$$

$$P_2 = 0 \text{ psia}$$

$$P_3 = 0 \text{ psia}$$

$$LG = P_1 R / 2 = 119 \times 84.0 / 2 = 4998 \text{ lbs/in}$$

BY _____ DATE _____
CHKD. BY _____ DATE _____

SUBJECT _____

SHEET NO. 61 OF _____
JOB NO. _____

Case 2 Gate Valve Closed w/
transient temp. dist.
(30 min. warm up)

For this loading case the
following loads were applied
to the model:
(See Figure 11)

$$P_1 = 119.0 \text{ PSIA}$$

$$P_2 = 0.0 \text{ PSIA}$$

$$P_3 = 0.0 \text{ PSIA}$$

$$LG = PR/2 = 119 \times 84.0 / 2 = 4998 \text{ lb/in}$$

The transient temperature distributions
vs. joint locations are shown on the
next page. See figure 10 to find
the relative joint location with
respect to the model

also, see figure 7b

Transient temp. dist. Gate Valve Closed

		$\alpha(T-T_{ref})$
1	0.	.000000
3	0.	.000000
4	50.	.000365
6	350.	.002555
7	356.	.002599
10	350.	.002555
14	94.	.000686
17	0.	.000000
20	0.	.000000
32	73.	.000533
35	129.	.000942
38	197.	.001438
41	20.	.000166
45	282.	.002059
46	305.	.002227
66	307.	.002190
67	357.	.002606
78	334.	.002437
79	301.	.002190
93	329.	.002365

$T_{ref} = 2000R$

$\alpha = .730 \times 10^{-5} 1/IN^{\circ}F$

or $T_{ref} = -260^{\circ}F$

ORIGINAL PAGE IS
 OF POOR QUALITY

The meridian and circumferential thermal strains (θ_s, θ_ϕ) are defined to be

$$\theta_s = \int_{t_0}^t \alpha_s dt, \quad \theta_\phi = \int_{t_0}^t \alpha_\phi dt.$$

$$\alpha = \alpha_s = \alpha_\phi = \text{constant} \quad \therefore \theta_s = \theta_\phi = \alpha T$$

BY _____ DATE _____

SUBJECT _____

SHEET NO. 63 OF _____

CHKD. BY _____ DATE _____

JOB NO. _____

Case 3 Gate Valve Closed w/
transient temp. dist.
(4 hour warm up time)

For this loading case the following
loads were applied to the
model: (See figure 11)

$$P_1 = 119.0 \text{ PSIA}$$

$$P_2 = 0 \text{ PSIA}$$

$$P_3 = 0 \text{ PSIA}$$

$$LG = P_1 R / 2 = 119 \times 84.0 / 2 = 4998 \text{ lb/in.}$$

The transient temperature distributions
vs. joint locations are shown
on the next page. See figure 10
to find the relative joint location
with respect to the model.

also, see figure 7c.

BY _____ DATE _____
 CHKD. BY _____ DATE _____

SUBJECT _____

SHEET NO. 64 OF _____
 JOB NO. _____

Transient - Gate Valve Closed
 $t = 4.0$ Hours

JOINT	T-TREF °R	$\alpha(T-TREF)$
1	0.	.0
3	0.	.0
4	55.	.000293
6	347.	.00185
7	355.	.001892
10	347.	.00185
14	124.	.000661
17	8.	.000043
20	5.	.000027
32	47.	.000251
35	82.	.000437
38	140.	.000746
41	205.	.001093
45	280.	.001492
46	223.	.00189
66	300.	.001599
67	355.	.001892
78	300.	.001599
79	300.	.001599
93	323.	.001722

$T_{ref} = 200. \text{ } ^\circ R$

$\alpha = .533 \times 10^{-5} \text{ IN/IN } ^\circ F$
 or $T_{ref} = -260 \text{ } ^\circ F$

The meridian and circumferential thermal strains (θ_s, θ_ϕ) are defined to be

$$\theta_s = \int_{t_0}^t \alpha_s dt \quad \theta_\phi = \int_{t_0}^t \alpha_\phi dt.$$

$\alpha = \alpha_s = \alpha_\phi = \text{Constant} \therefore \theta_s = \theta_\phi = \alpha T$

Stress and buckling results

Note: a definition on how to read the following data.

Figure 8 is a reference surface plot of the model indicating the +s and z direction.

The inside surface shall be defined as the reference surface and the outside surface as measured in the z direction away from the reference surface.

See figure 9; the inside surface shall be the continuous line with "+" indicated on it. the outside surface will then be the continuous line next to it.

Figure 10 is a plot showing the node locations the double numbers indicates the end then the beginning of a subsegment, the triple numbers a branch points.

ORIGINAL PAGE IS
OF POOR QUALITY

BY _____ DATE _____

SUBJECT _____

SHEET NO. 66 OF _____

CHKD. BY _____ DATE _____

JOB NO. _____

The integer numbers shown on figure 11 correspond to the integers shown on figure 12.

Here they indicate the different regions of the model relative to the continuous meridian of distance.

BY _____ DATE _____
CHKD BY _____ DATE _____

SUBJECT _____

SHEET NO. 67 OF _____
JOB NO. _____

Results load Case 1

Valve closed

BY _____ DATE _____

SUBJECT _____

SHEET NO. 68 OF _____

CHKD. BY _____ DATE _____

JOB NO. _____

From computer run AGZ and shown in figures 12, 13, 14 are stress plots of σ_{hoop} and $\sigma_{meridian}$ vs. meridian distance.

Figure 12 is a numerical average of the inside and outside surface stresses, in the circumferential and meridian directions.

Figure 13 outside surface stresses in the circumferential and meridian directions.

Figure 14 inside surface stresses in the circumferential and meridian directions.

ORIGINAL PAGE IS
OF POOR QUALITY

BY _____ DATE _____

SUBJECT _____

SHEET NO. 69 OF _____

CHKD. BY _____ DATE _____

JOB NO. _____

Primary plus Secondary stress intensity

inside surface.

$$\sigma_1 = -15.1 \text{ ksi}$$

$$\sigma_2 = -12.4 \text{ ksi}$$

$$\sigma_3 = -0.119 \text{ ksi}$$

$$s_{12} = -15.1 - (-12.4) = -2.6 \text{ ksi}$$

$$s_{23} = -12.4 \text{ ksi} - (-0.119) = -12.281 \text{ ksi}$$

$$s_{31} = -0.119 - (-15.1) = -14.881 \text{ ksi}$$

$$s = |-14.881| = 14.881 \text{ ksi}$$

$$P_L + P_b + Q < 3 S_m$$

$$14.881 < 3 S_m = 60 \text{ ksi} \quad \text{OK}$$

BY _____ DATE _____
CHKD. BY _____ DATE _____

SUBJECT _____

SHEET NO. 70 OF _____
JOB NO. _____

Out side Surface

$$\sigma_1 = -10.0 \text{ KSI}$$

$$\sigma_2 = 2.8 \text{ KSI}$$

$$\sigma_3 = 0 \text{ KSI}$$

$$s_{12} = -10 - 2.8 = -12.8 \text{ KSI}$$

$$s_{23} = 2.8 - 0 = 2.8 \text{ KSI}$$

$$s_{31} = 0 - (-10) = +10 \text{ KSI}$$

$$s = |-12.8| = 12.8 \text{ KSI}$$

$$P_c + P_b + Q < 3S_m$$

$$12.8 < 60 \text{ KSI OK}$$

The primary plus secondary stress intensity meets the stress evaluation criteria.

Membrane Stress (intensity)

Primary local Membrane stress intensity

(See Fig 12)

$$\sigma_1 = 5 \text{ KSI}$$

$$\sigma_2 = -3 \text{ KSI}$$

$$\sigma_3 = -0.06 \text{ KSI}$$

$$S_{12} = 5 - (-3) = 8.0 \text{ KSI}$$

$$S_{23} = -3 - (-0.06) = -2.94 \text{ KSI}$$

$$S_{31} = -0.06 - 5 = -5.06 \text{ KSI}$$

$$S_1 = |8.0| = 8.0 \text{ KSI}$$

$$P_M = 8.0 < 20.0 \text{ KSI OK}$$

Since the stress intensity is $< S_m (20 \text{ KSI})$
The stress intensity meets the criteria for
general membrane stress intensity

General Membrane Stress

$$S = 15.53 \text{ KSI} < 18.2 = S \quad \text{OK}$$

This region meets the stress evaluation
criteria for general Membrane stress.

Bifurcation buckling of bulkhead.

There were several runs made to determine the critical load factor for the Bulkhead region. Here the prestressed "Value Closed" condition was run. The loading condition generated the maximum pressure differential across the bulkhead ($P=119$ PSIG).

Early attempts to extract an eigenvalue generated negative eigenvalues bifurcating on the shell.

A step wise procedure of shifting the eigen value was adopted until a positive eigenvalue was generated.

The following table summarizes the eigen value solution, which indicates that the minimum critical load factor of 26.58 when applied to the 119 PSI external pressure would require a pressure of 3163. psi before buckling would occur.

Value Closed loading condition
Bifurcation Buckling load factor

Harmonic Number	λ	Location	Node
2	26.58	Bulkhead	14
3	28.89	"	14
4	35.17	"	1
5	41.78	"	15,16
6	48.85	"	17
7	56.30	"	17
8	-43.52	Shell	51,52
9	-32.03	"	51,52
10	-25.46	"	51,52

BY _____ DATE _____

SUBJECT _____

SHEET NO. 74 OF _____

CHKD. BY _____ DATE _____

JOB NO. _____

Also, along with the linear analysis a non-linear analysis was performed with a load factor of 26 on a prestressed structure, using a 119 PSI pressure, an estimated load factor of $\lambda_c = 25.30$ was found.

Which is in good agreement with the linear bifurcation buckling analysis.

BY DATE.....

SUBJECT.....

SHEET NO. ⁷⁵ OF.....

CHKD. BY..... DATE.....

JOB NO.

Results load Case 2

Gate Valve closed w/ Tran, Temp dist.

w/ 30 Min warm up time

BY _____ DATE _____
CHKD. BY _____ DATE _____

SUBJECT _____

SHEET NO. 19 OF _____

JOB NO. _____

From computer run NMW and shown in figures 15, 16 and 17 are stress plots of σ_{hoop} and $\sigma_{meridian}$ vs. meridian length.

Figure 15 is a numerical average of the inside and outside surface stresses in the circumferential and meridian directions

Figure 16 outside surface stresses in the circumferential and meridian directions.

Figure 17 inside surface stresses in the circumferential and meridian directions.

MEMBRANE STRESS (INTENSITY)

PRIMARY LOCAL MEMBRANE STRESS INTENSITY

$$\sigma_1 = 22.0 \text{ KSI}$$

$$\sigma_2 = -3.0 \text{ KSI}$$

$$\sigma_3 = -1.06 \text{ KSI}$$

$$S_{12} = 22 - 3 = 25 \text{ KSI}$$

$$S_{23} = -3 - (-1.06) = -2.94 \text{ KSI}$$

$$S_{31} = -1.06 - 22 = -22.06 \text{ KSI}$$

$$S = |25.0| = 25 \text{ KSI}$$

$$P_L = 25 < 30 \text{ KSI} = 1.55m \text{ OK}$$

$$\sqrt{RT} = 20.6" \quad \text{EXCURSION LENGTH} = 4"$$

SINCE THE STRESS INTENSITY IS $< 1.55m$
 THE STRESS INTENSITY MEETS THE
 CRITERIA FOR LOCAL MEMBRANE
 STRESS INTENSITY.

GENERAL MEMBRANE STRESS

$$S = 15.5 \text{ KSI} < 18.2 = 5 \text{ OK}$$

THIS REGION MEETS THE STRESS
 EVALUATION CRITERIA FOR GENERAL
 MEMBRANE STRESS.

BY _____ DATE _____

SUBJECT _____

SHEET NO. 18 OF _____

CHKD. BY _____ DATE _____

JOB NO. _____

THERMAL STRESSES

PRIMARY PLUS SECONDARY STRESS INTENSITY

INSIDE SURFACE

$$\sigma_1 = 20.0 \text{ KSI}$$

$$\sigma_2 = -45.5 \text{ KSI}$$

$$\sigma_3 = -.119 \text{ KSI}$$

$$s_{12} = 20 - (-45.5) = 65.5 \text{ KSI}$$

$$s_{23} = -45.5 - (-.119) = 45.38 \text{ KSI}$$

$$s_{31} = -.119 - 20 = -20.119 \text{ KSI}$$

$$s = |65.5| \text{ KSI}$$

SEE SHAKE DOWN ANALYSIS

FOR THIS TRANSIENT

TEMPERATURE PROFILE

STRESS ANALYSIS, THAT

WAS RUN ON SPAR.

$$S_T = 118 \text{ KSI}$$

$$65.5 < 118 \text{ KSI} \quad \text{OK}$$

BY _____ DATE _____

SUBJECT _____

SHEET NO. 79 OF _____

CHKD. BY _____ DATE _____

JOB NO. _____

THERMAL STRESSES

PRIMARY PLUS SECONDARY STRESS INTENSITY

OUTSIDE SURFACE

$$\sigma_1 = 0 \text{ KSI}$$

$$\sigma_2 = -54.5 \text{ KSI}$$

$$\sigma_3 = 0 \text{ KSI}$$

$$S = |-54.5| = 54.5 \text{ KSI}$$

$$P_c + P_s + Q = 54.5 < 60 \text{ KSI OK}$$

THE PRIMARY PLUS SECONDARY
STRESS MEET THE STRESS
EVALUATION CRITERIA.

BY _____ DATE _____

SUBJECT _____

SHEET NO. 80 OF _____

CHKD. BY _____ DATE _____

JOB NO. _____

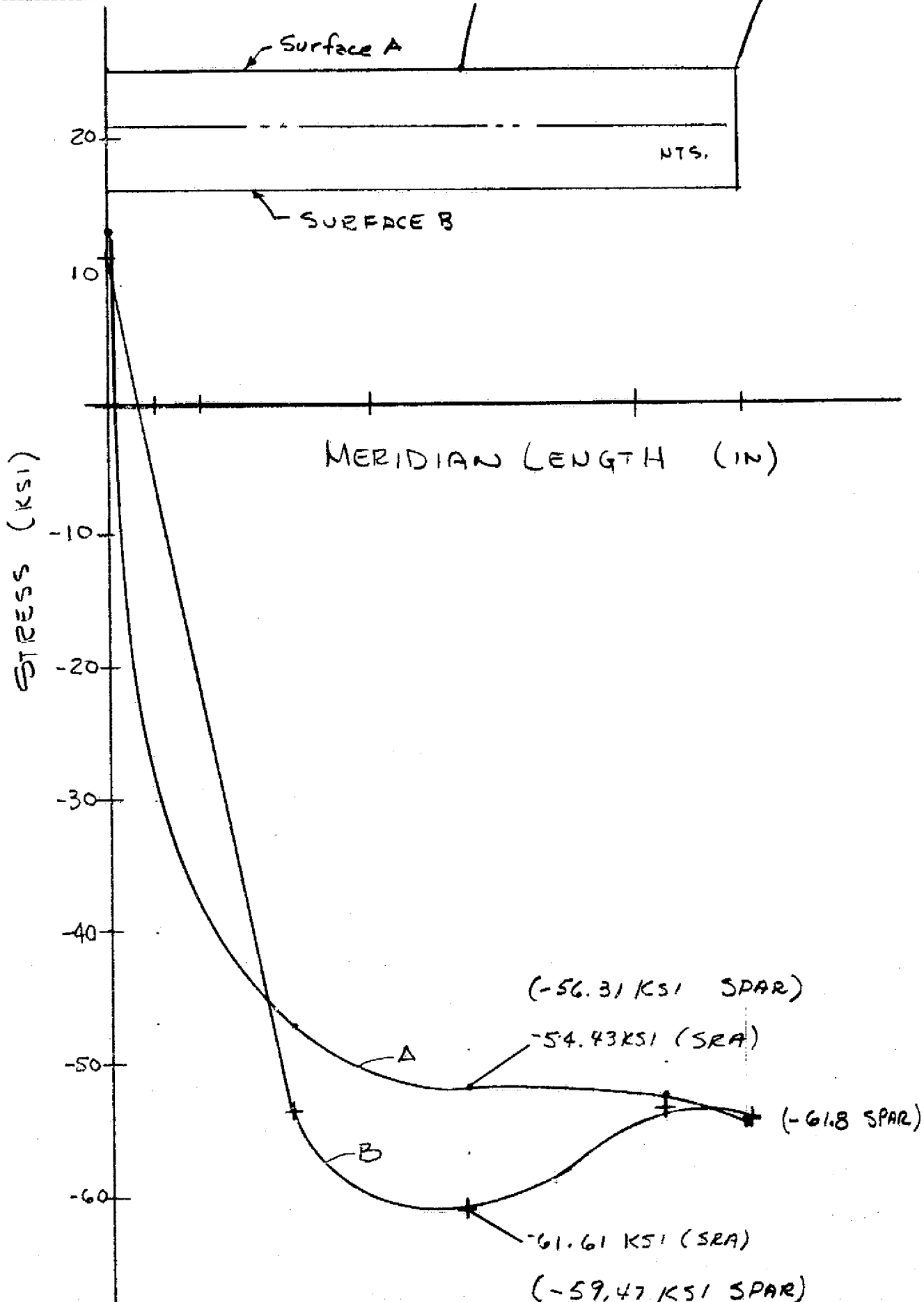

Value closed Transient temperature
critical load factors:

Buckling analysis
(warm up time 30 min)

Harmonic NUMBER	λ	Location	Node
2	22.80	Bulkhead	14
3	27.36	"	15,16
4			
5	-		
6			
7			
8			
9			
10			

BY _____ DATE _____ SUBJECT _____ SHEET NO. 82 OF _____
CHKD. BY _____ DATE _____ JOB NO. _____

Results load Case 3

Gate Valve Closed w/ Trans. Temp dist.

w/ 4 Hour warm up time.

From computer run ESS and shown in figures 18, 19, and 20 are stress plots of σ_{hoop} and $\sigma_{meridian}$ vs. meridian length.

Fig. 18 is a numerical average of the inside and outside surface stresses in the circumferential and meridian directions.

Fig. 19 outside surface stresses in the circumferential and meridian directions.

Fig. 20 inside surface stresses in the circumferential and meridian direction.

BY _____ DATE _____

SUBJECT _____

SHEET NO. 84 OF _____

CHKD. BY _____ DATE _____

JOB NO. _____

MEMBRANE STRESS (INTENSITY)

PRIMARY LOCAL MEMBRANE STRESS INTENSITY THERMAL

$$\sigma_1 = -39.1 \text{ KSI}$$

$$\sigma_2 = 0 \text{ KSI}$$

$$\sigma_3 = -1.06 \text{ KSI}$$

$$s_{12} = -39.1 - 0 = -39.1 \text{ KSI}$$

$$s_{23} = 0 - (-1.06) = 1.06 \text{ KSI}$$

$$s_{31} = -1.06 - (-39.1) = 38.04 \text{ KSI}$$

$$s = |-39.16| = 39.16 \text{ KSI}$$

$$P_L + P_B + Q = 39.16 \text{ KSI}$$

$$P_L + P_B + Q < 3S_u = 60 \text{ KSI} \quad \text{OK}$$

GENERAL MEMBRANE STRESS

$$s = 15.59 \text{ KSI} < 18.2 = S \quad \text{OK}$$

THIS REGION MEET THE STRESS
EVALUATION CRITERIA FOR
GENERAL MEMBRANE STRESS.

BY _____ DATE _____

SUBJECT _____

SHEET NO. 85 OF _____

CHKD. BY _____ DATE _____

JOB NO. _____

INSIDE SURFACE

$$\sigma_1 = -39.1 \text{ KSI}$$

$$\sigma_2 = 0 \text{ KSI}$$

$$\sigma_3 = -.119 \text{ KSI}$$

$$s_{12} = -39.1 - 0 = -39.1 \text{ KSI}$$

$$s_{23} = 0 - (-.119) = .119 \text{ KSI}$$

$$s_{31} = -.119 - (-39.1) = 38.981 \text{ KSI}$$

$$s = |-39.1| = 39.1 \text{ KSI}$$

$$P_t + P_b + Q < 3s_u$$

$$P_t + P_b + Q = 39.1 < 60 \text{ KSI OK}$$

BY _____ DATE _____

SUBJECT _____

SHEET NO. 86 OF _____

CHKD. BY _____ DATE _____

JOB NO. _____

OUTSIDE SURFACE

$$\sigma_1 = -39.1 \text{ KSI}$$

$$\sigma_2 = 0 \text{ KSI}$$

$$\sigma_3 = 0 \text{ KSI}$$

$$S_{12} = -39.1 - 0 = -39.1 \text{ KSI}$$

$$S_{23} = 0 - 0 = 0$$

$$S_{31} = 0 - (-39.1) = 39.1 \text{ KSI}$$

$$S = |39.1| = 39.1 \text{ KSI}$$

$$P_L + P_Q + Q = 39.1 < 3S_m = 60 \text{ KSI}$$

THE PRIMARY PLUS SECONDARY STRESS
INTENSITY MEETS THE STRESS
EVALUATION CRITERIA.

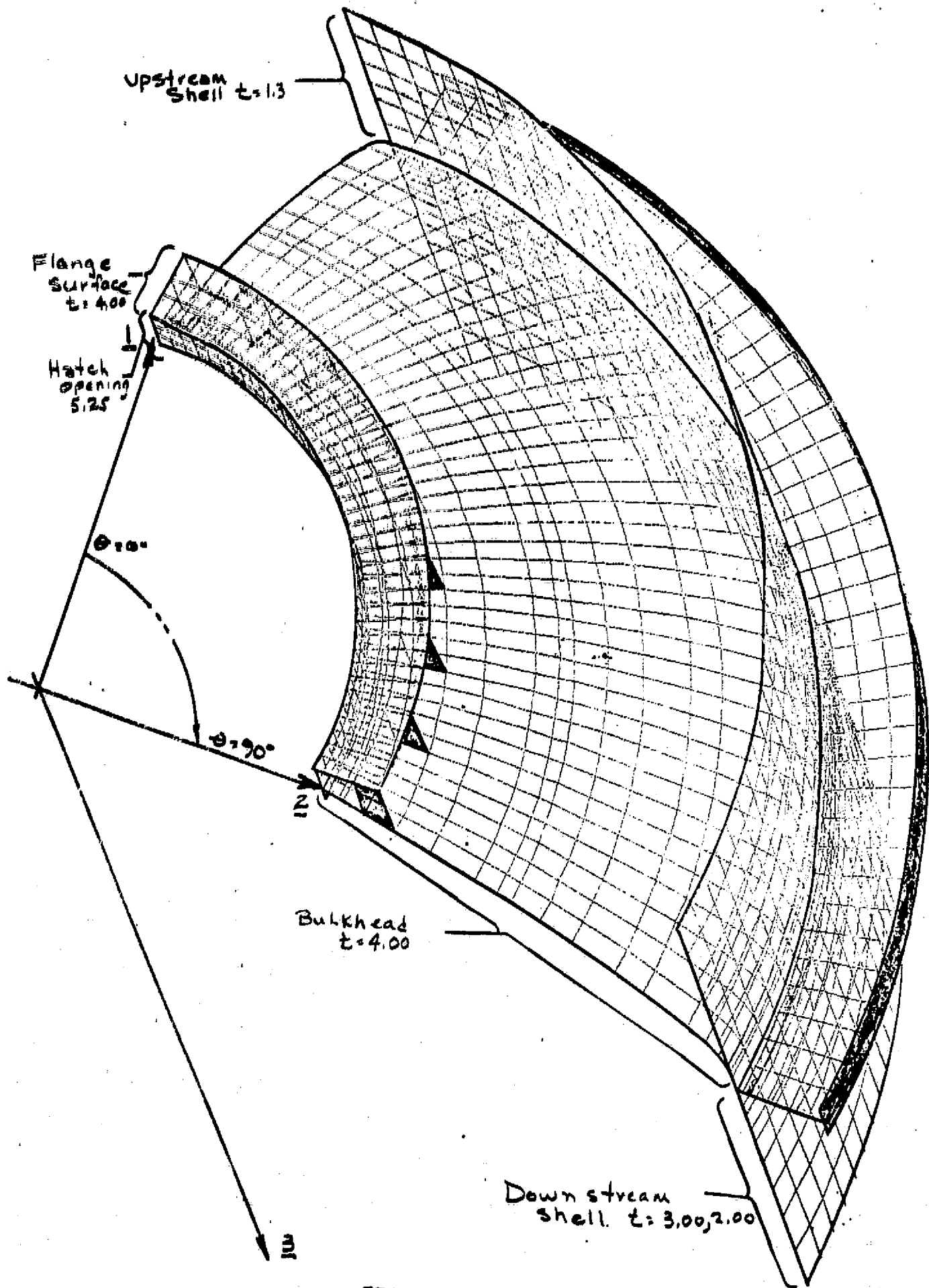

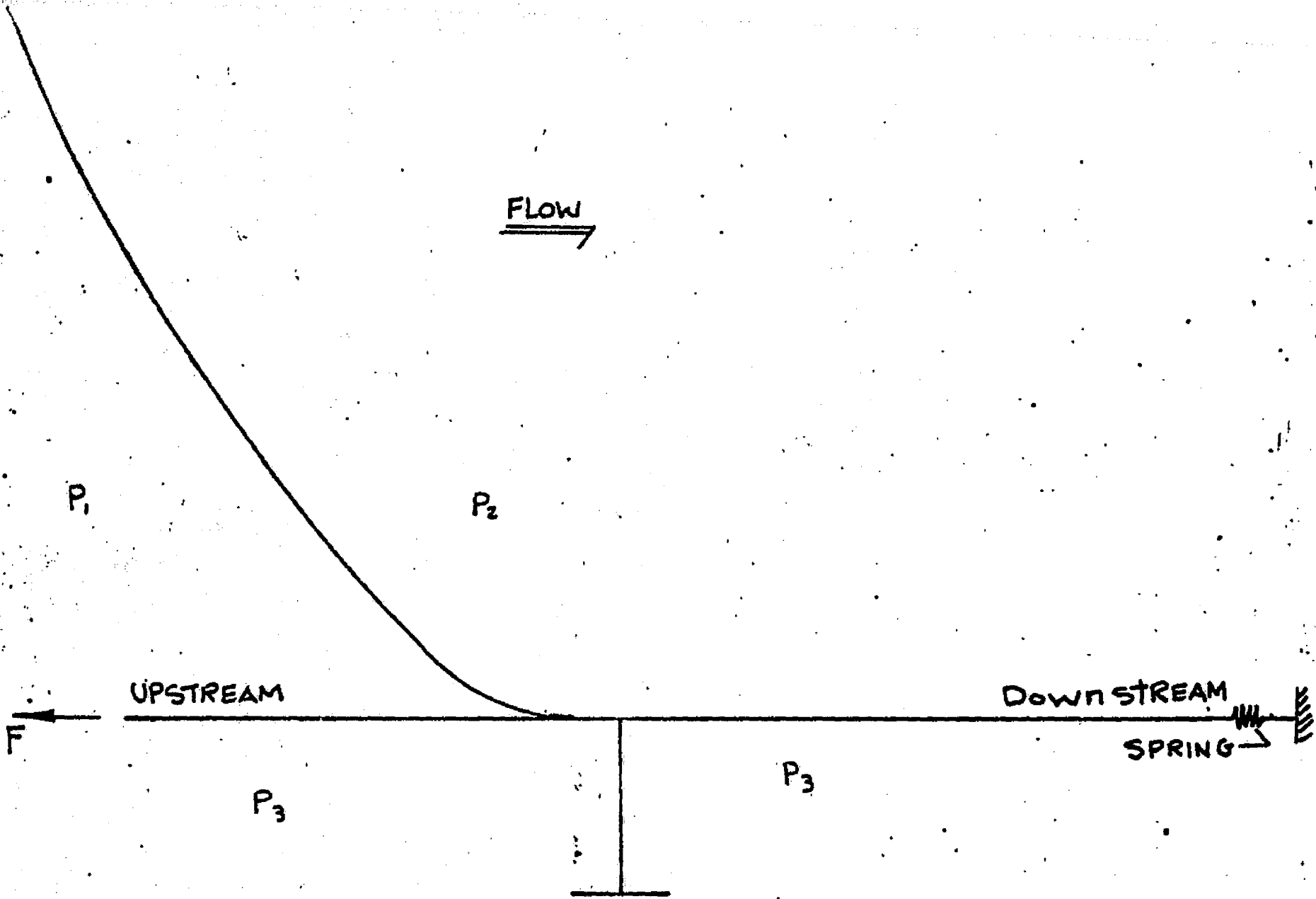

FIG. 3
NTF BULKHEAD
CROSS SECTION. VIEW

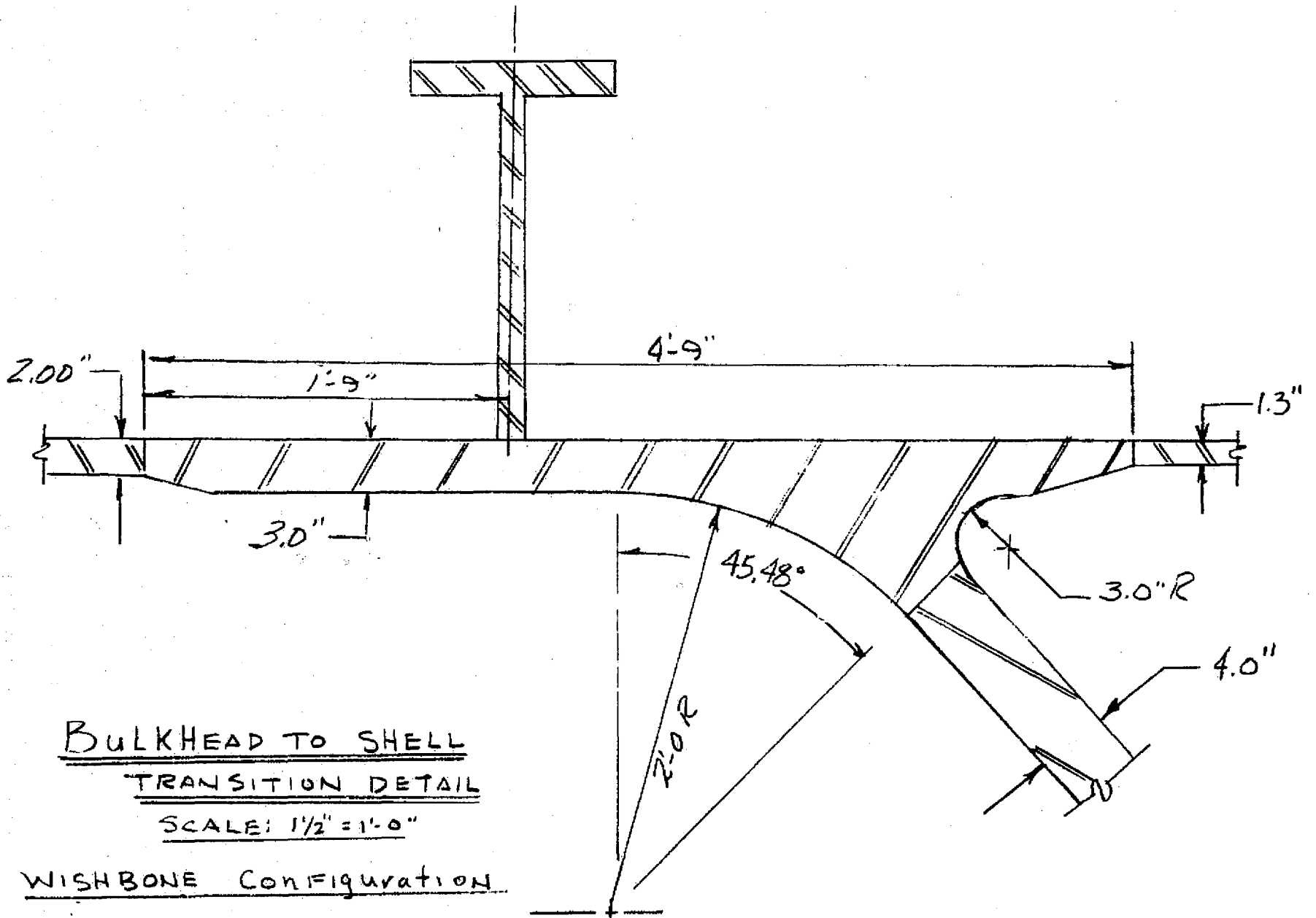
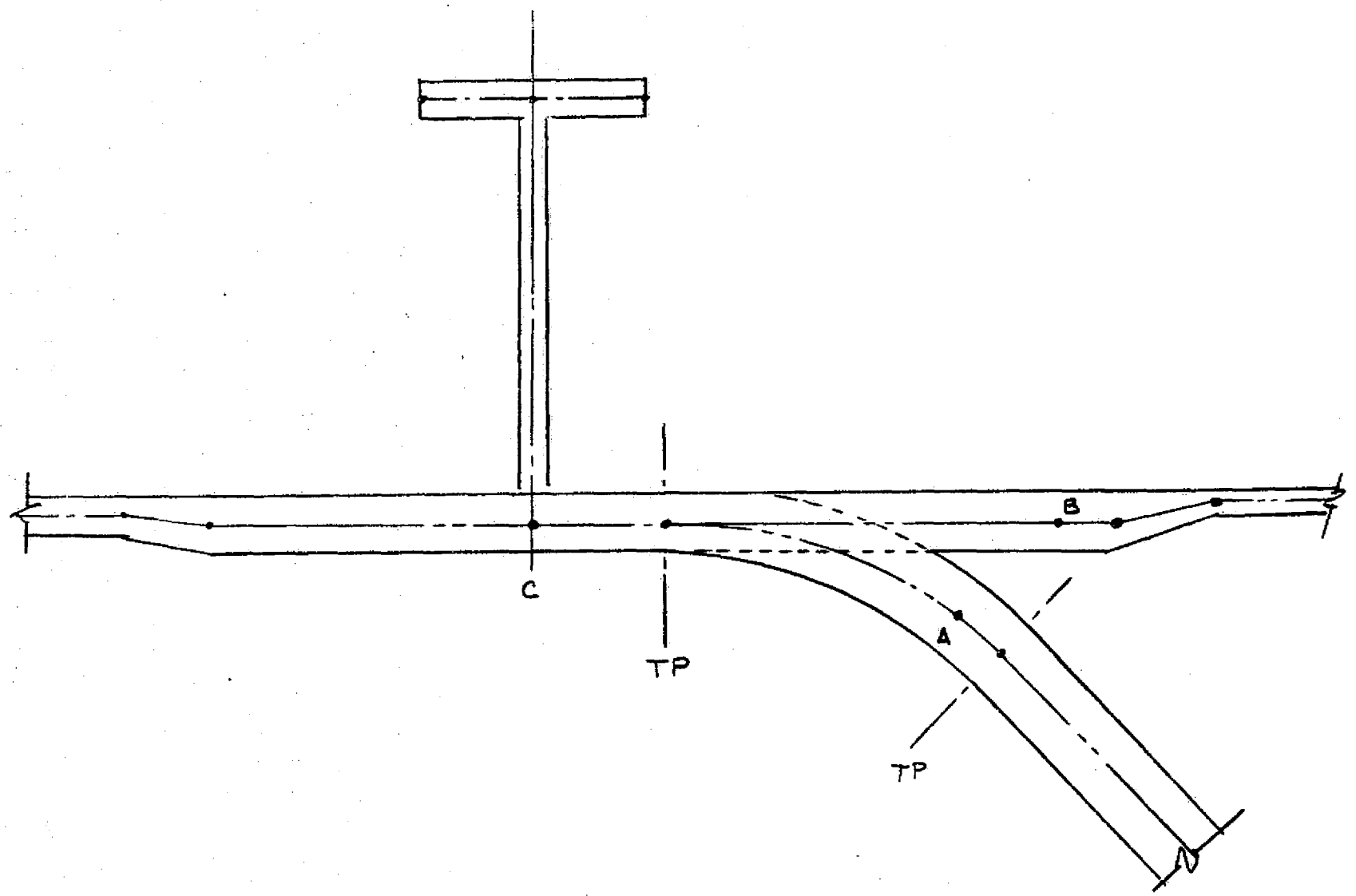
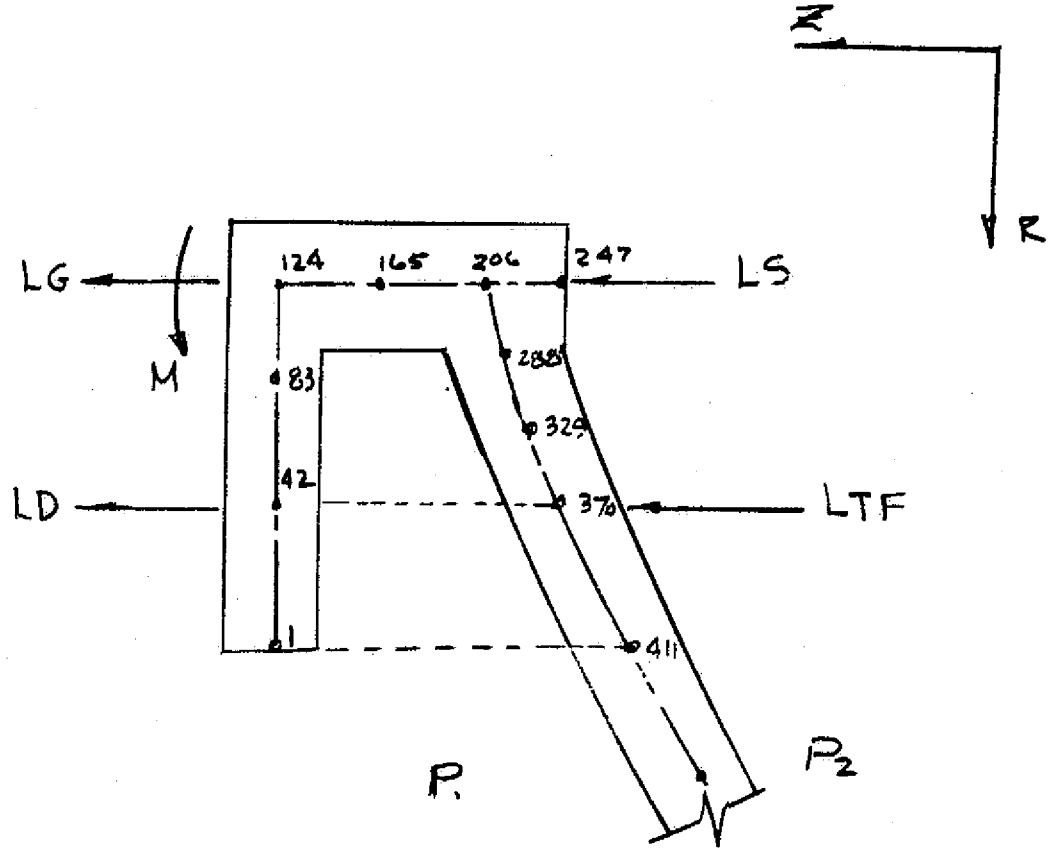

FIG. 3



WISHBONE CONFIGURATION
THE WAY IT WAS MODELED ON SPAR & SRA

FIG. 4



ORIGINAL PAGE IS
OF POOR QUALITY

FIG 5

BY _____ DATE _____

SUBJECT _____

SHEET NO. _____ OF _____

CHKD. BY _____ DATE _____

JOB NO. _____

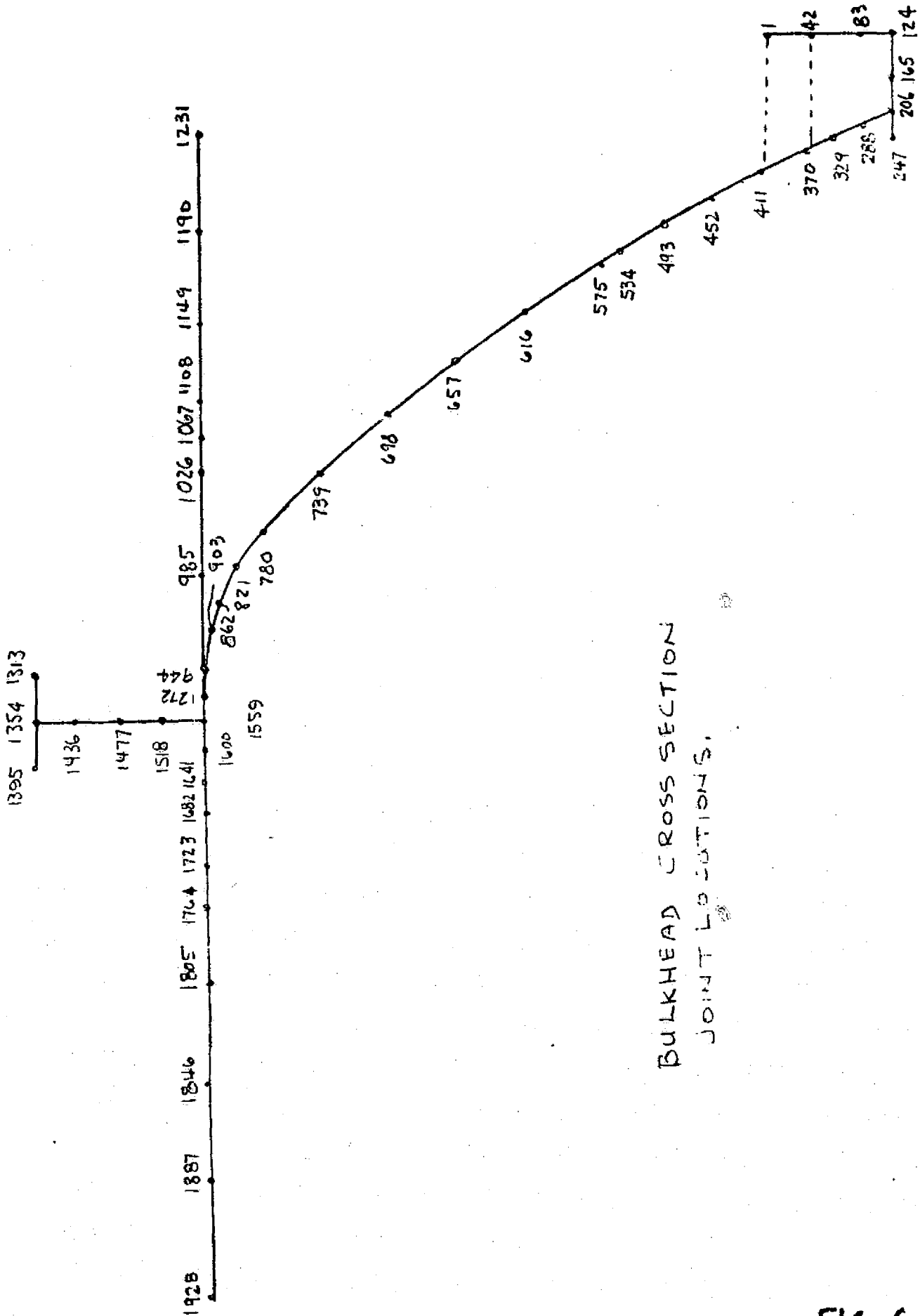

FIG 6

BY _____ DATE _____
 CHKD. BY _____ DATE _____

SUBJECT _____
 Steady State

SHEET NO. _____ OF _____
 JOB NO. _____

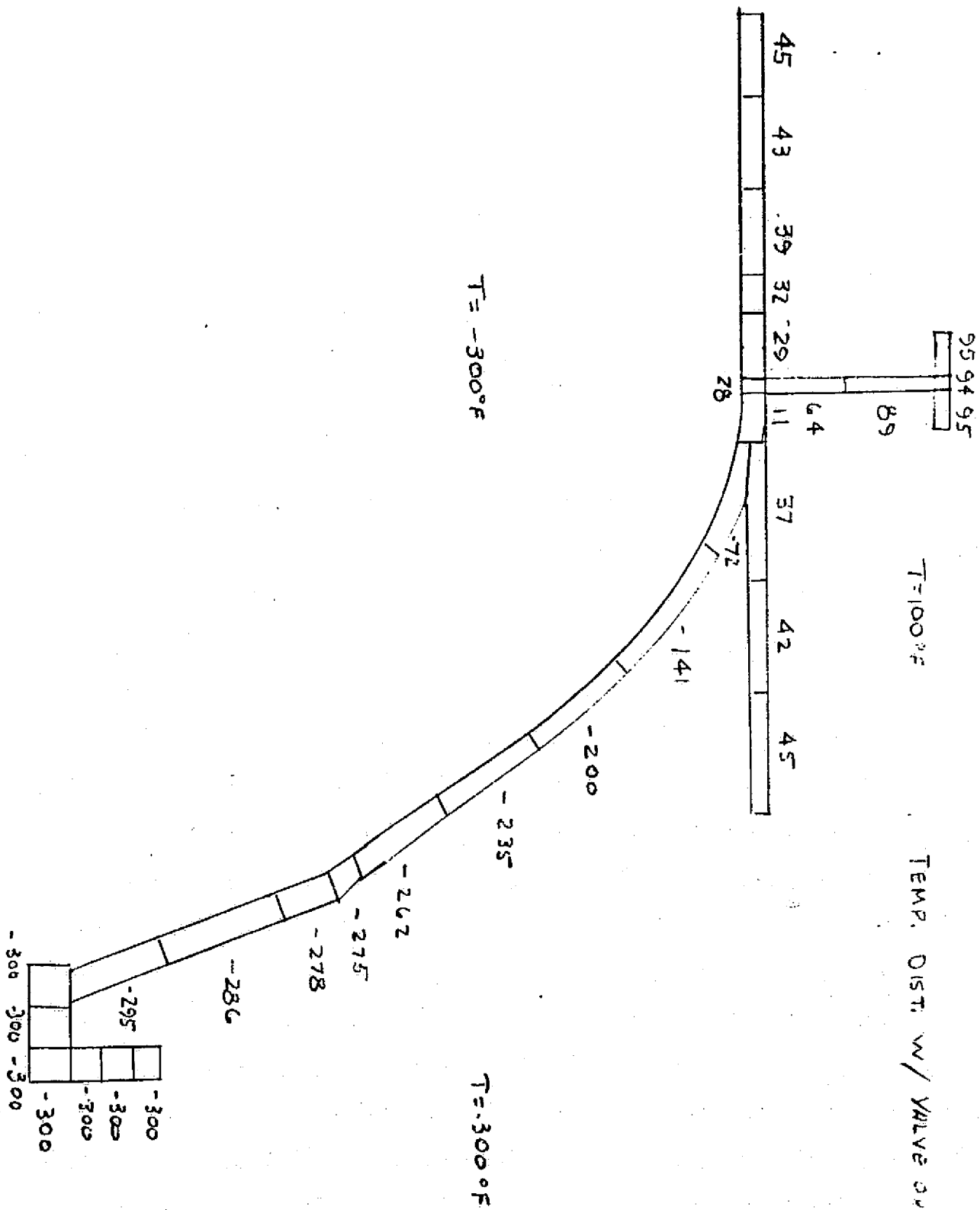
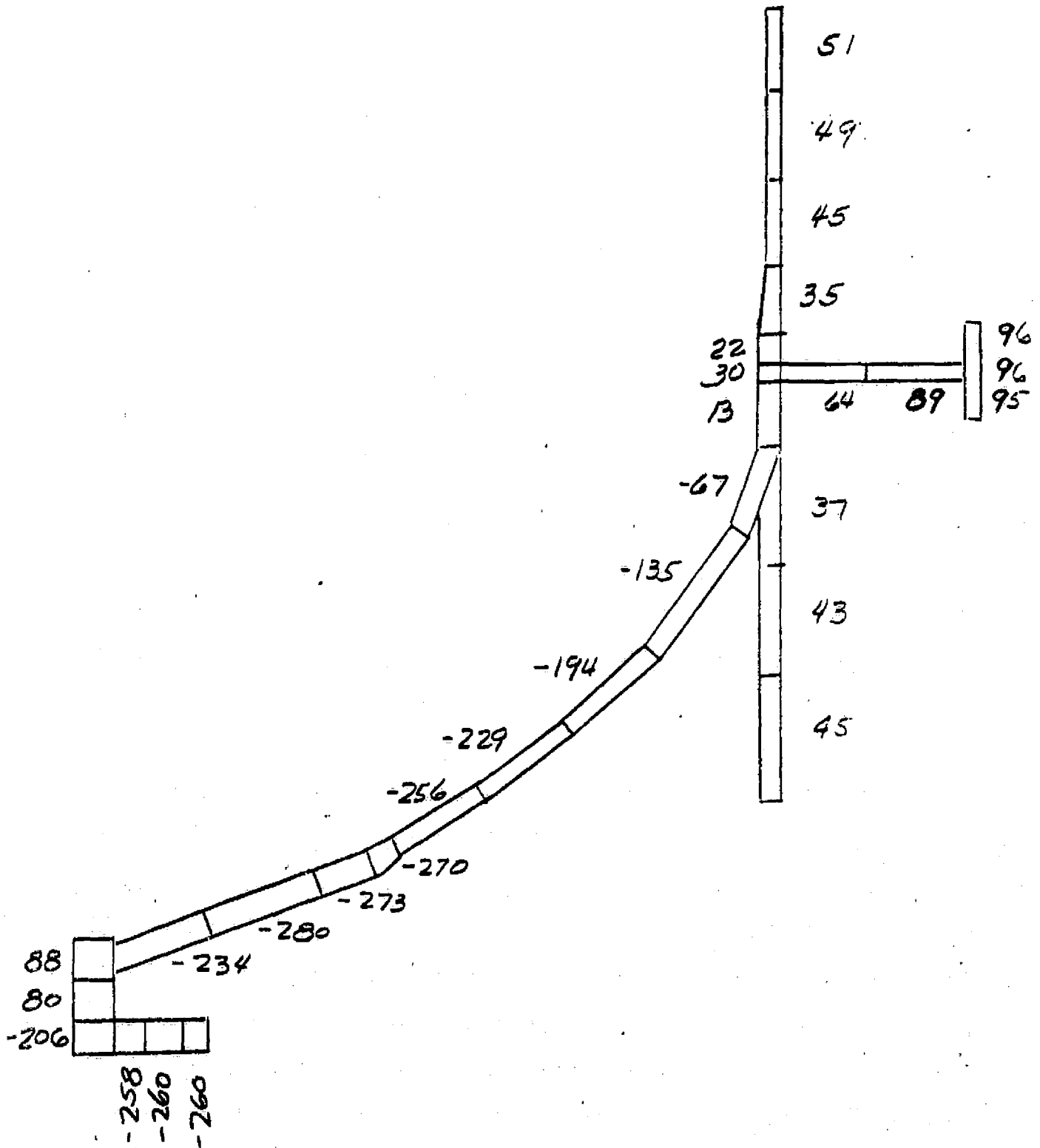

FIG. 7a

BY..... DATE.....
CHKD. BY..... DATE.....
.....

SUBJECT.....
Transient Temp. dist.
Heat up time 30 min.

SHEET NO..... OF.....
JOB NO.....
.....



(HEAT UP TIME OF 30 MIN)

FIG. 76

BY _____ DATE _____
 CHKD. BY _____ DATE _____

SUBJECT _____

SHEET NO. _____ OF _____
 JOB NO. _____

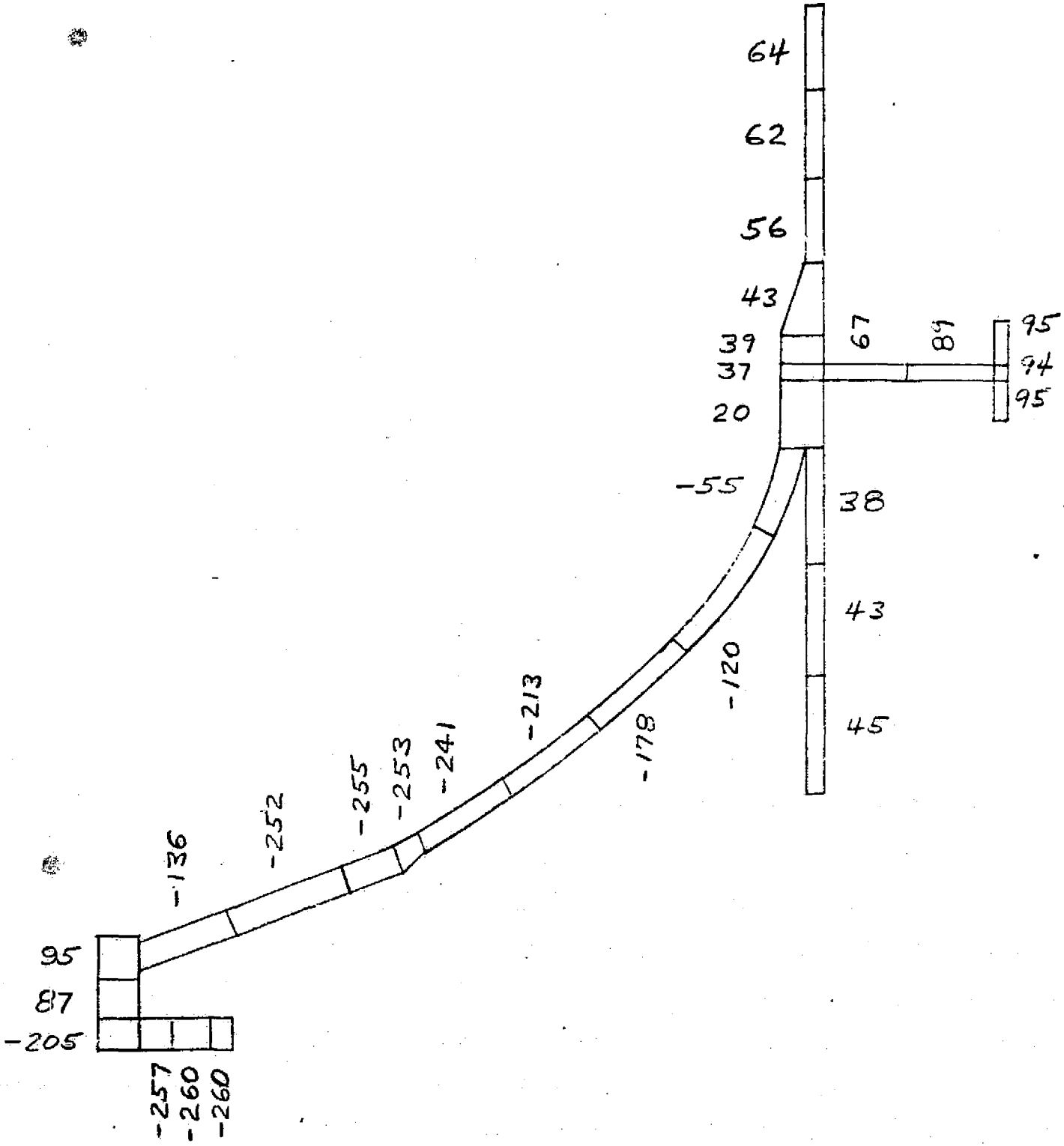
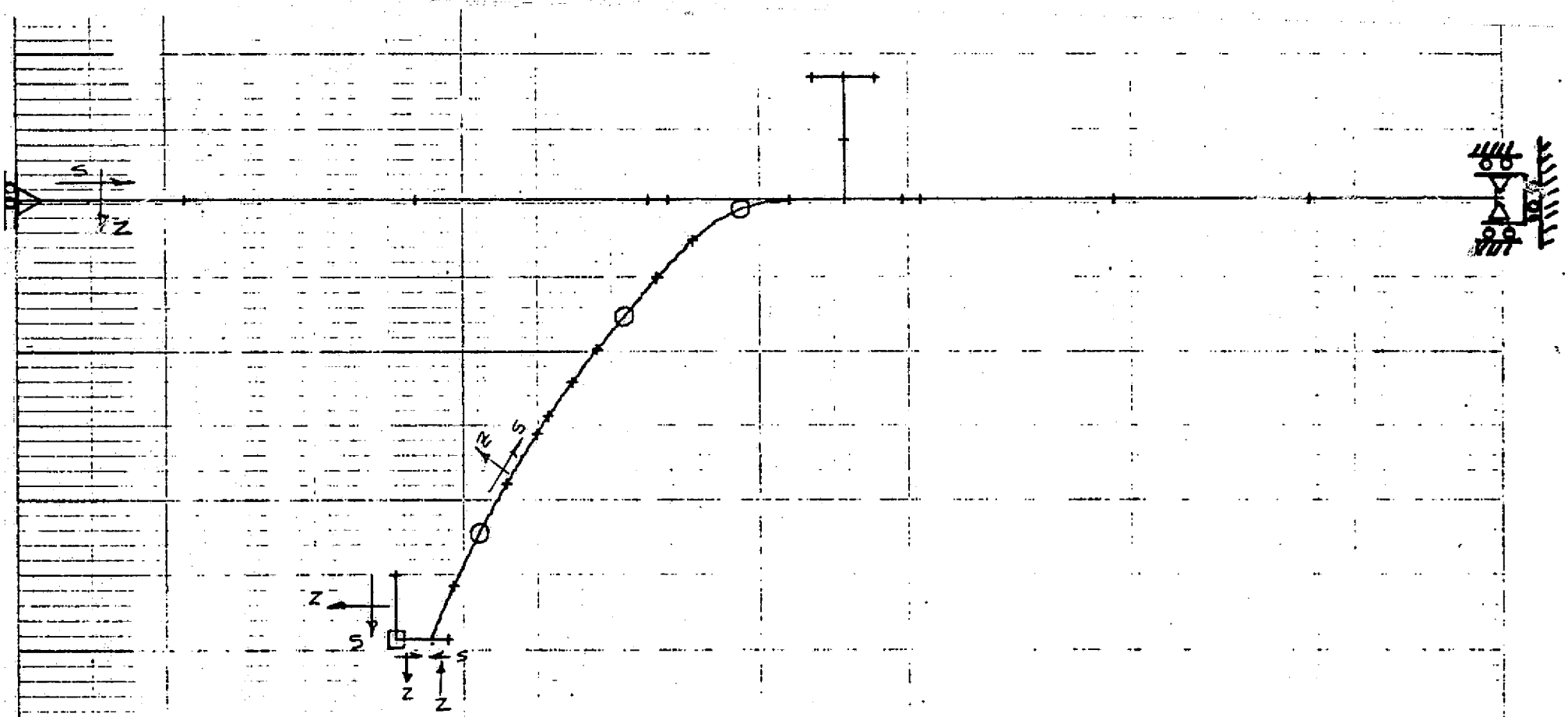
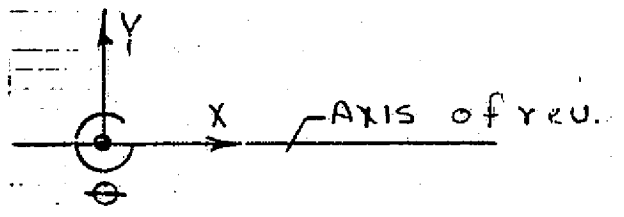

FIGURE - 7C

(HEAT UP TIME OF 4 HOURS)



SRAS REFERANCE SURFACE DEFINATION



UTF BULK HEAD
PROFILE PLOT
304 S.S.

ORIGINAL PAGE IS
OF POOR QUALITY

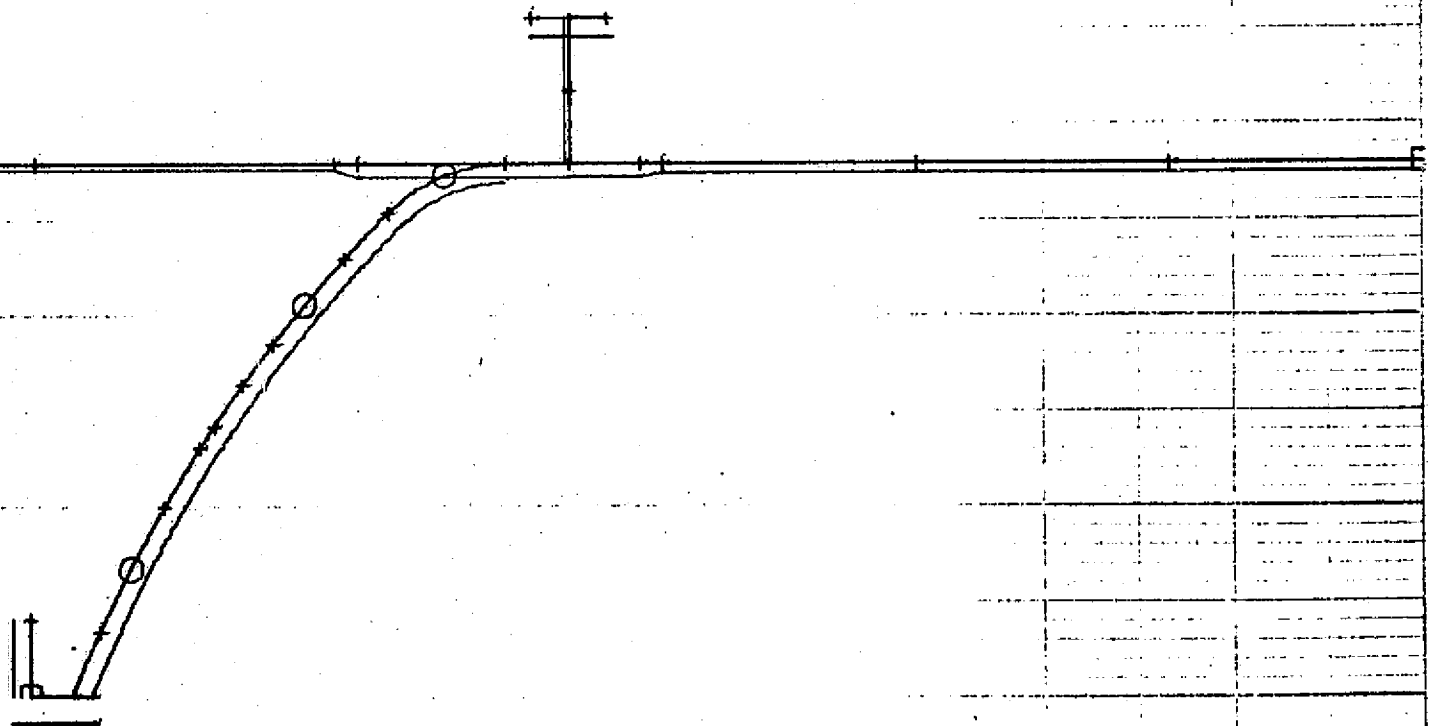
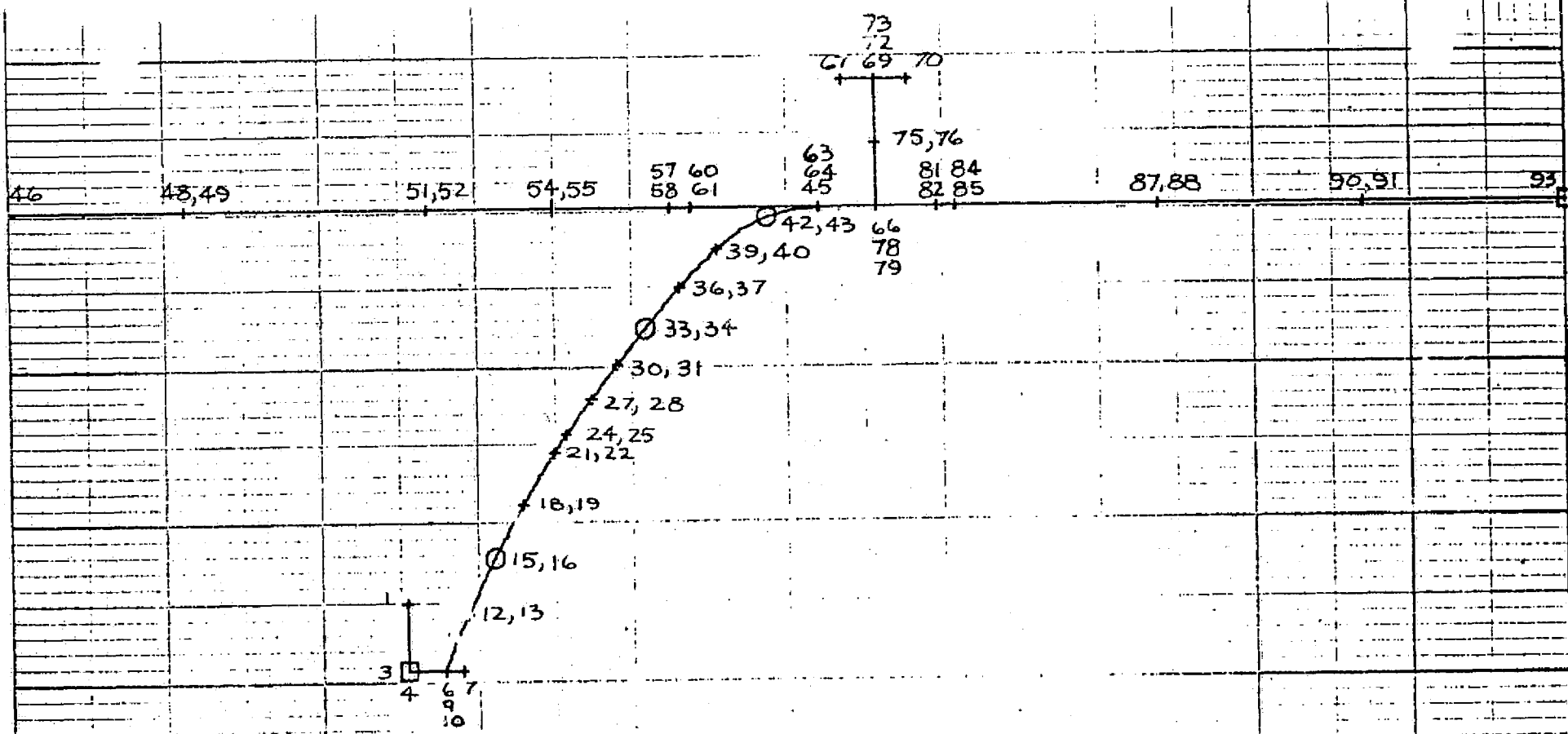

FIG. 9



SRA JOINT LOCATION

AXIS OF REV.

FIG. 10

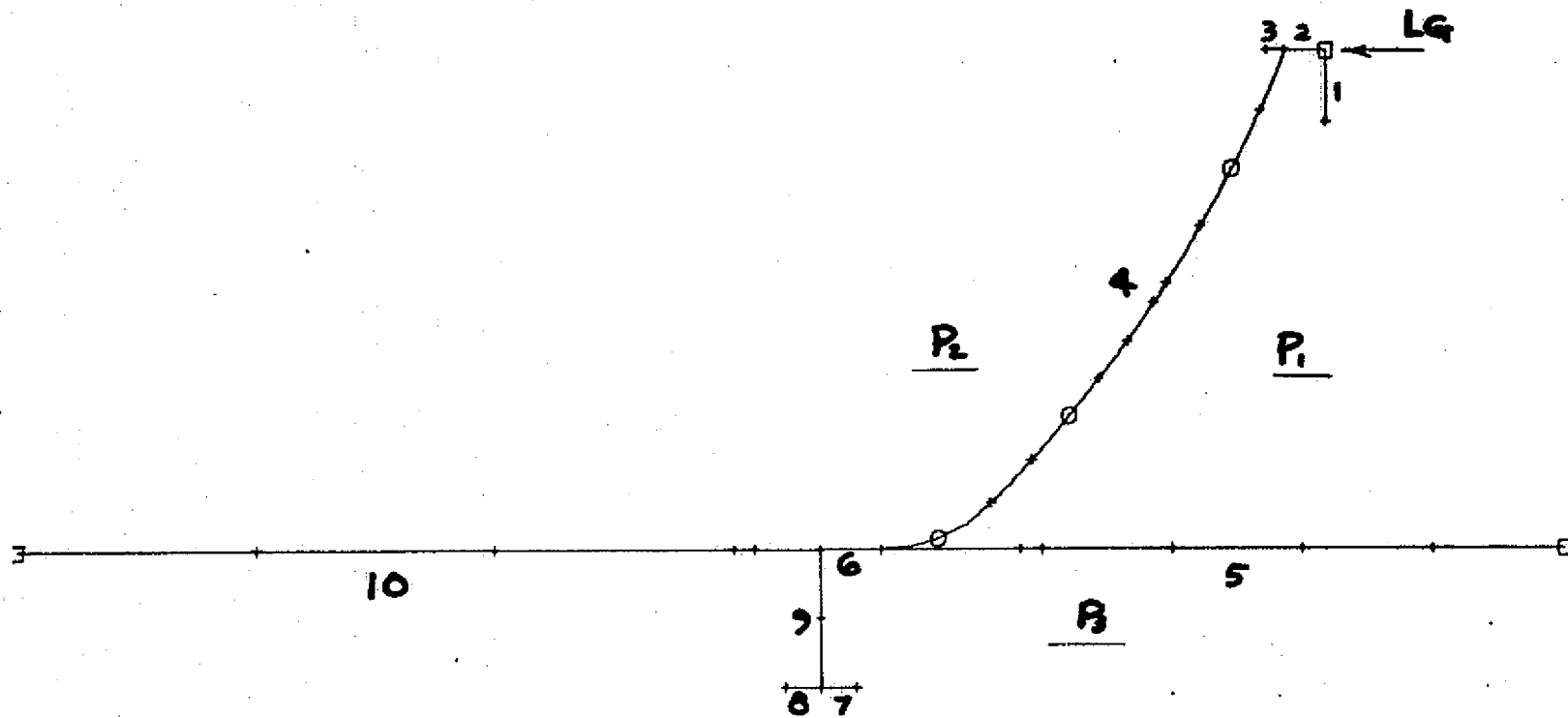

SRA REGION LOCATION

FIG. 12

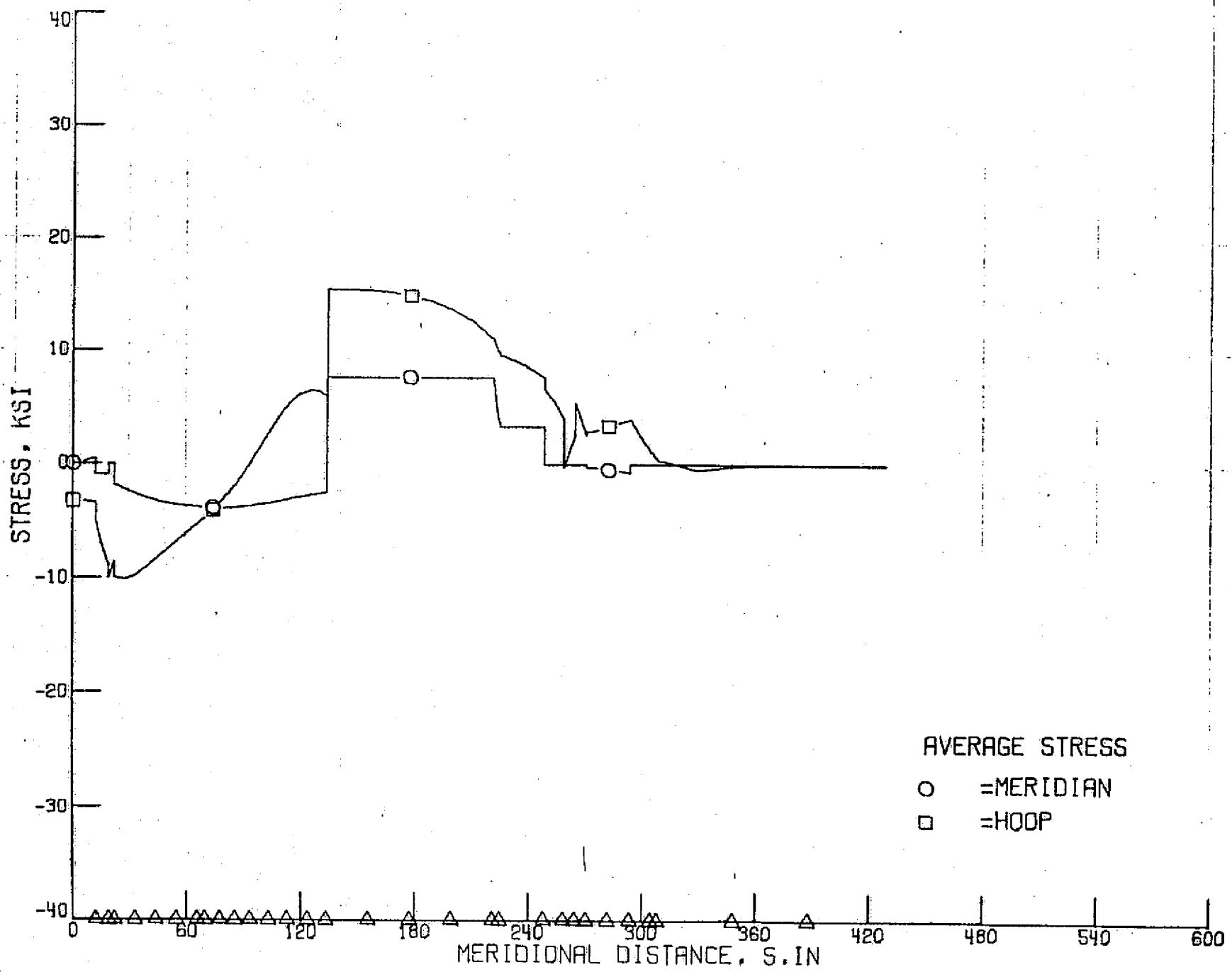
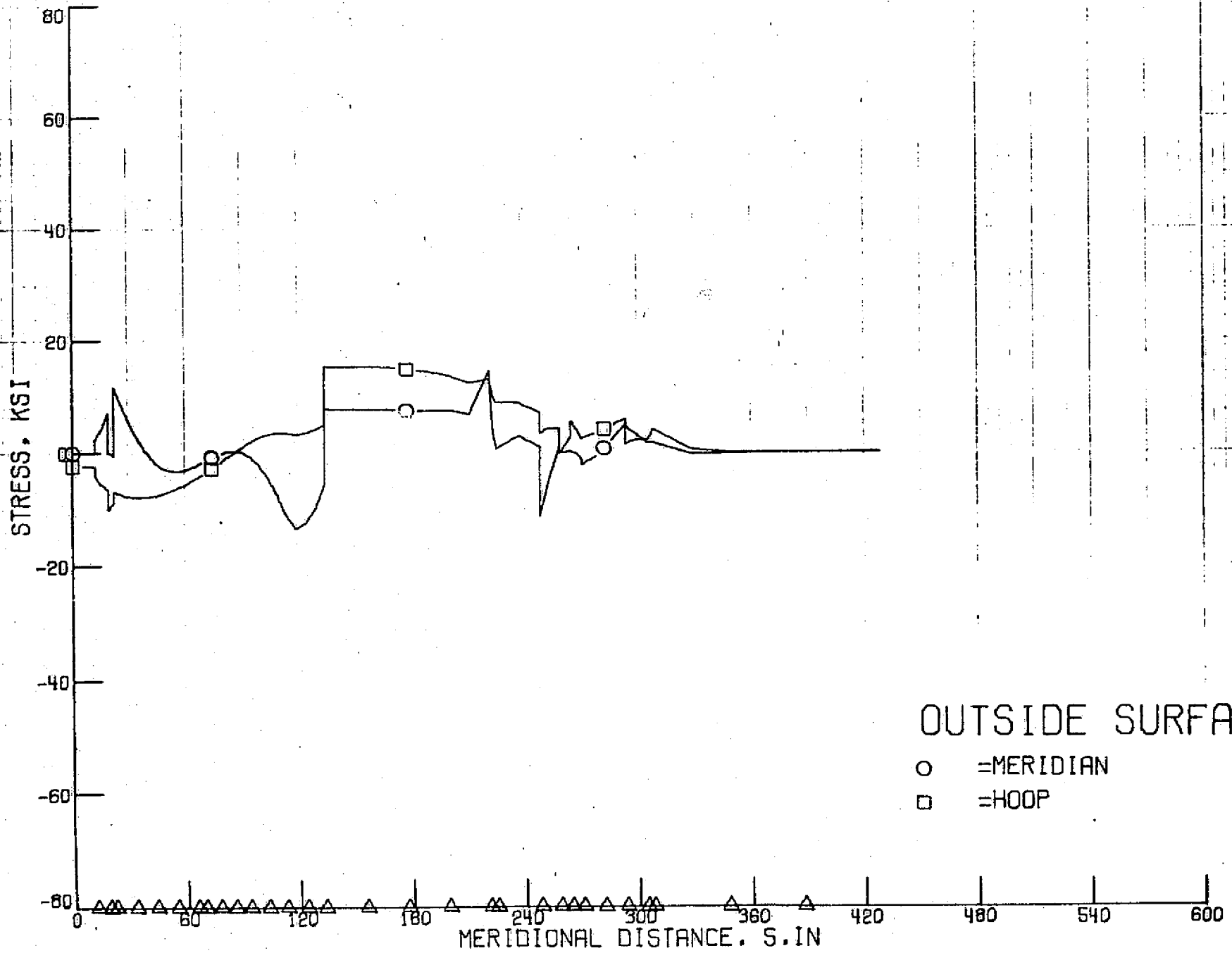
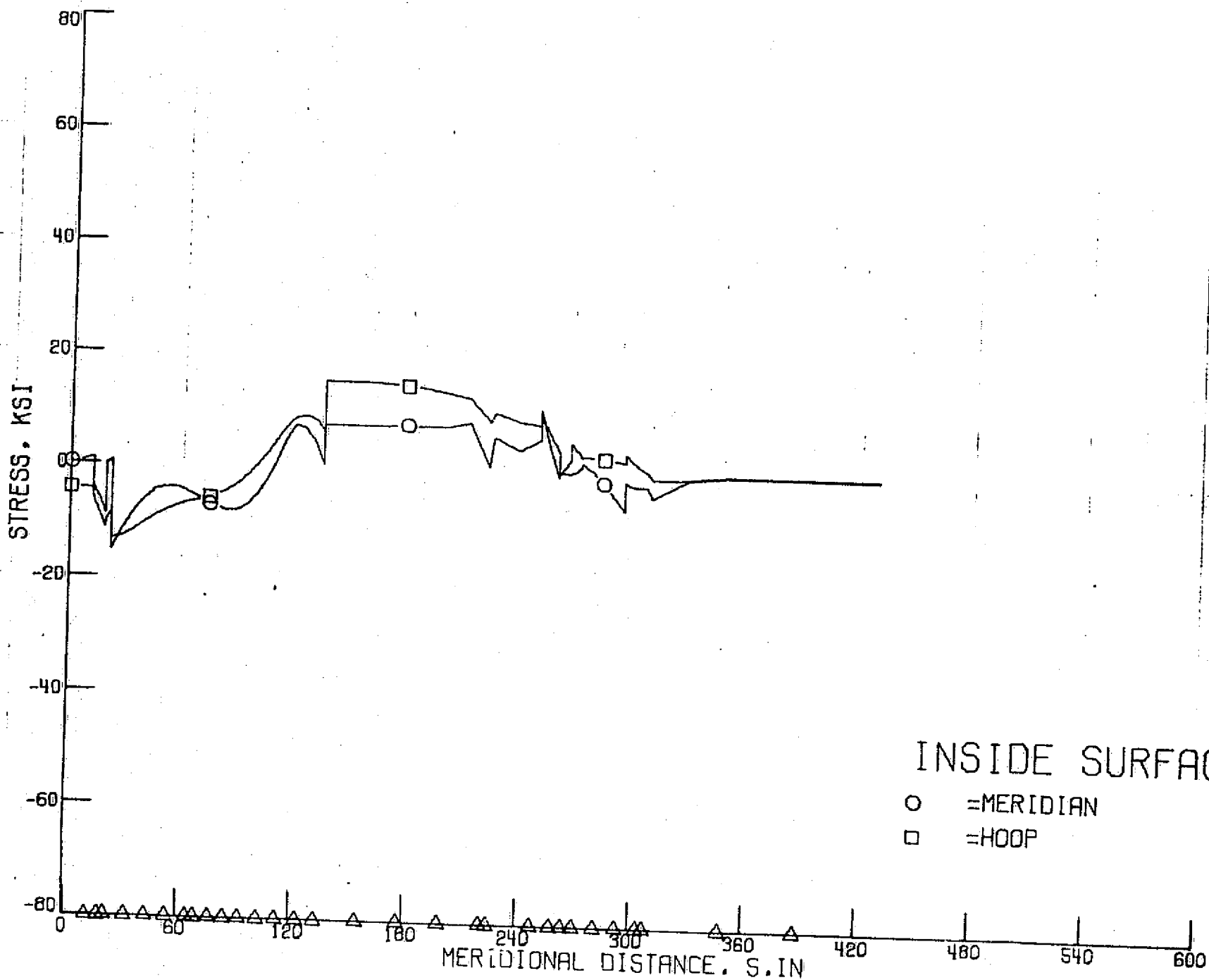

FIG. 13





INSIDE SURFACE

- =MERIDIAN
- =HOOP

FIG. 14

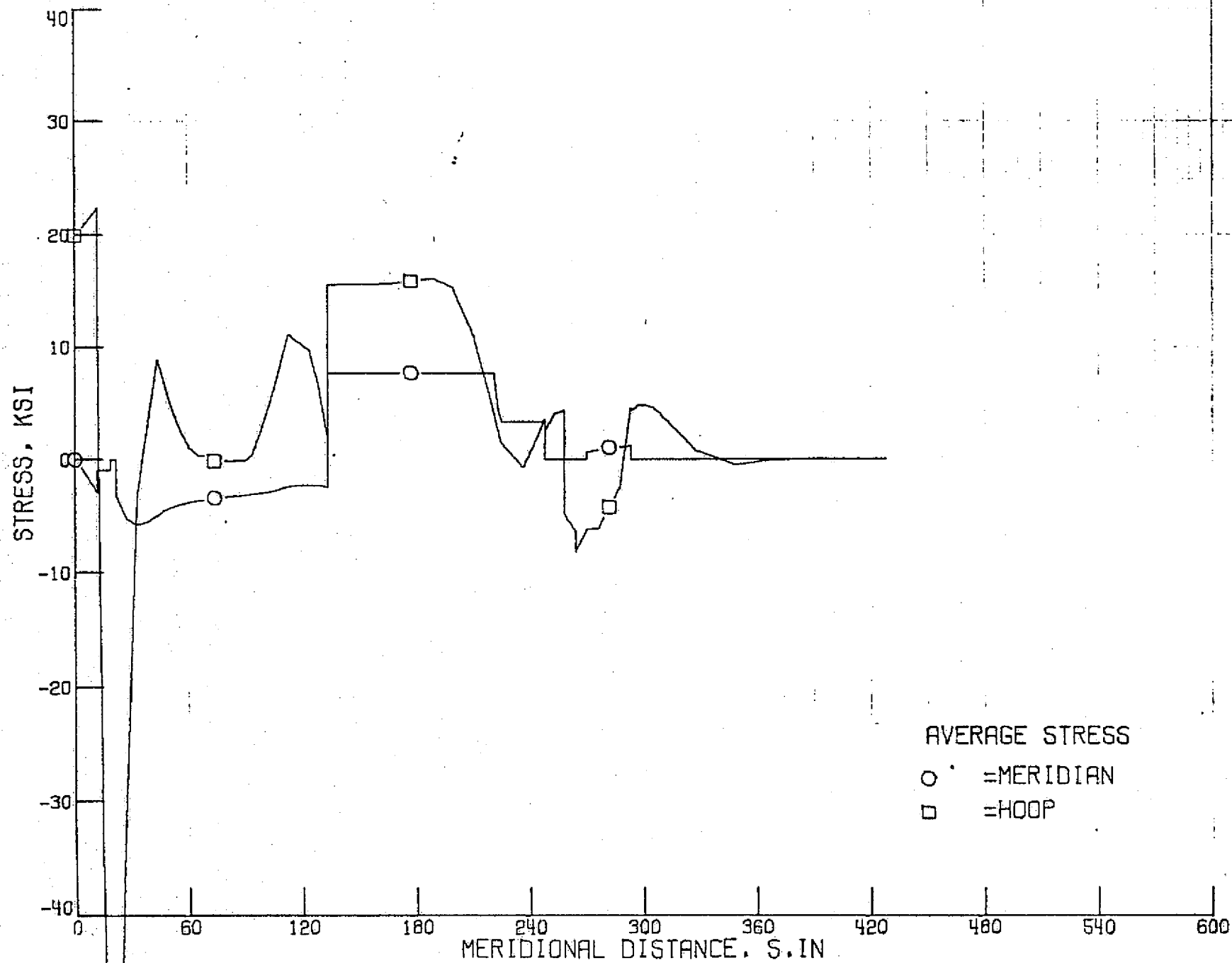

FIG. 15

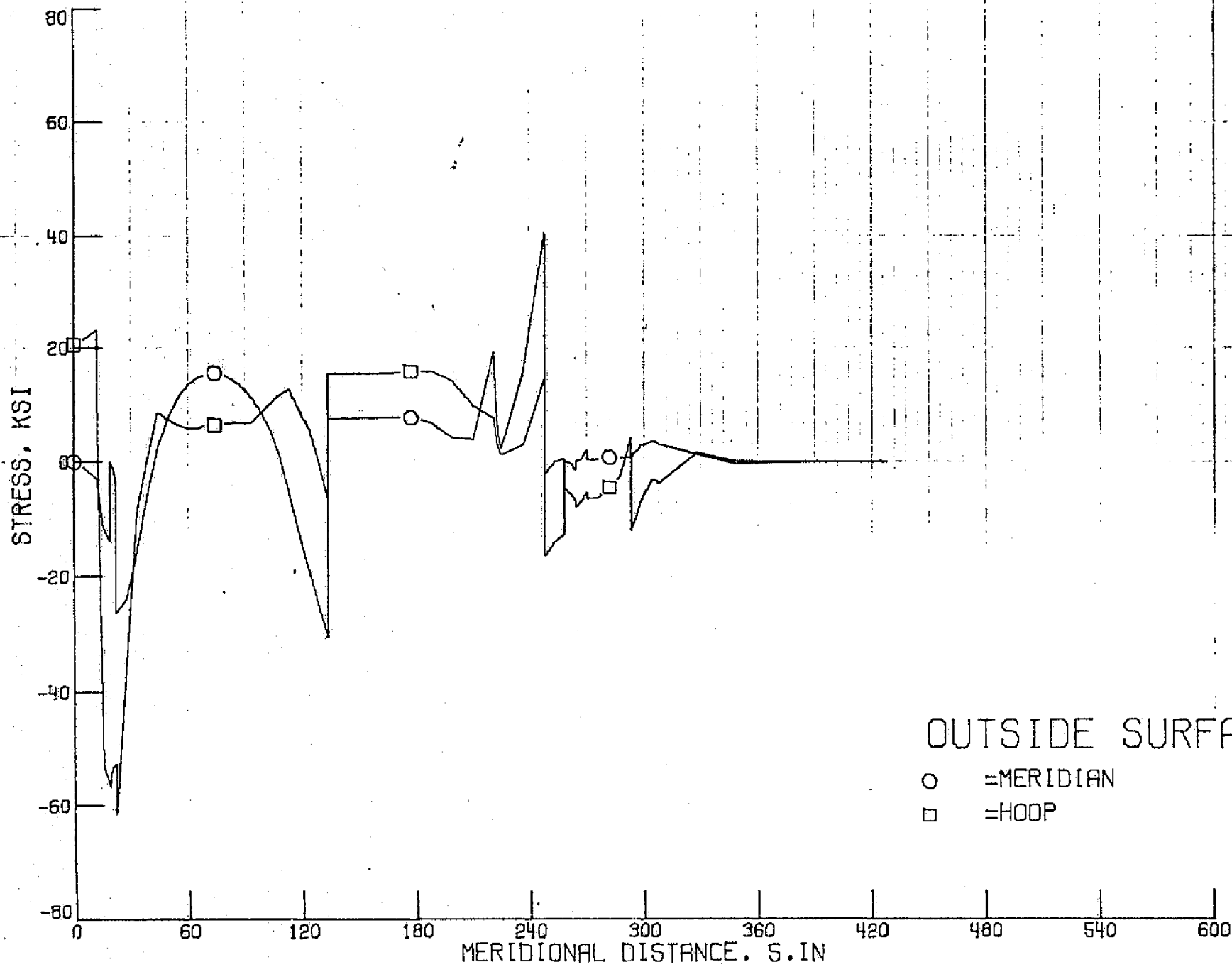

Fig 16

ORIGINAL PAGE IS
OF POOR QUALITY

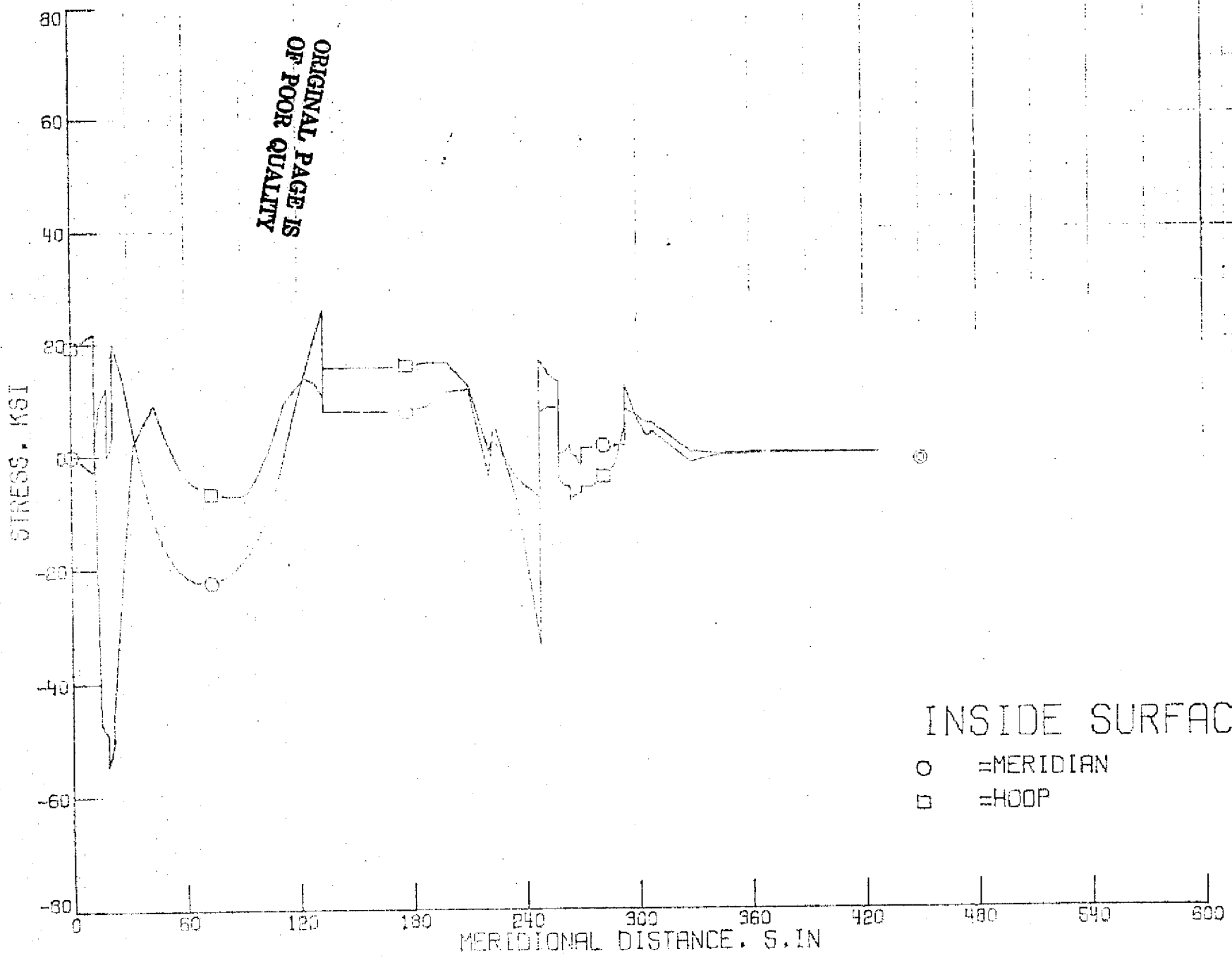

FIG. 17

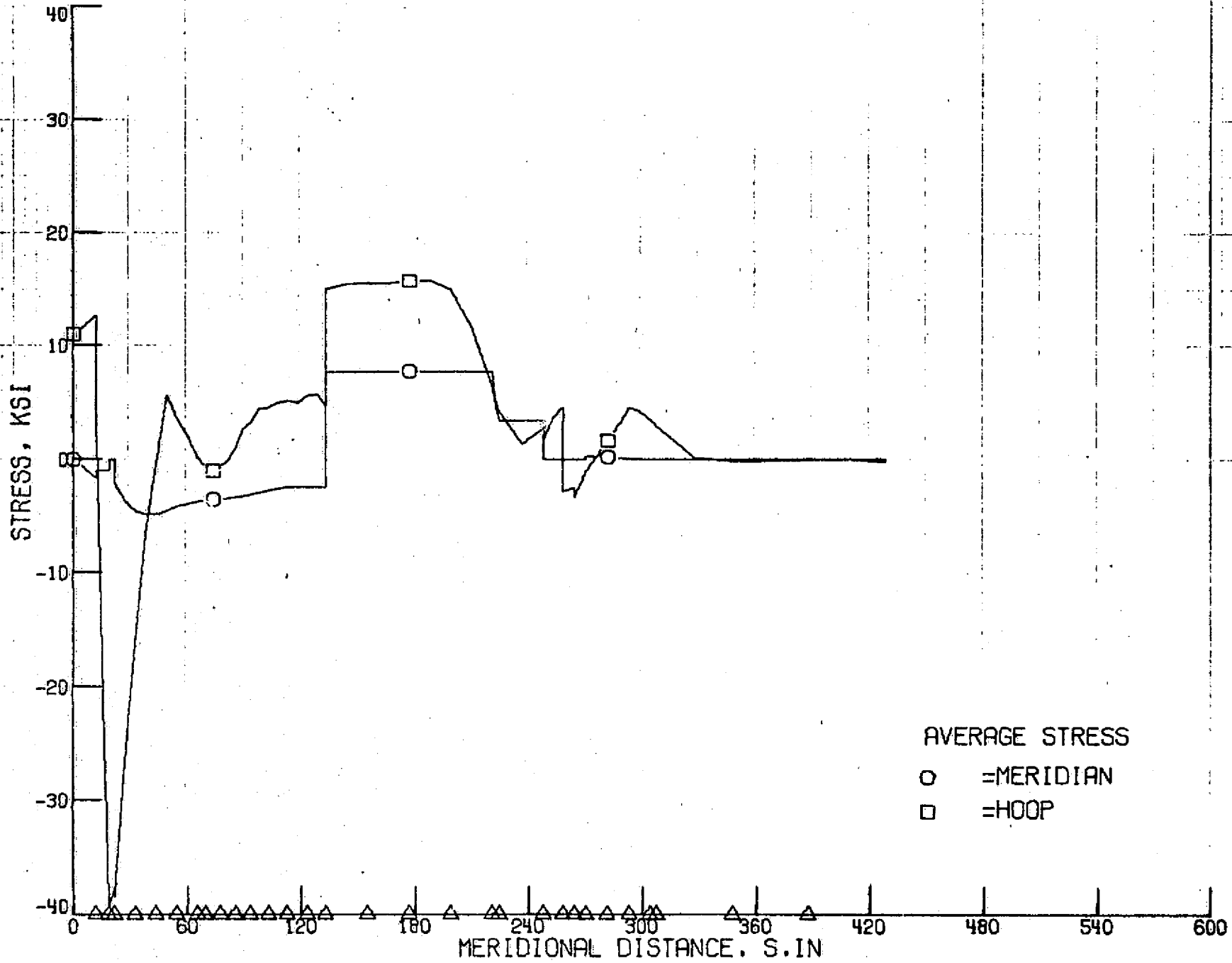

FIG. 18

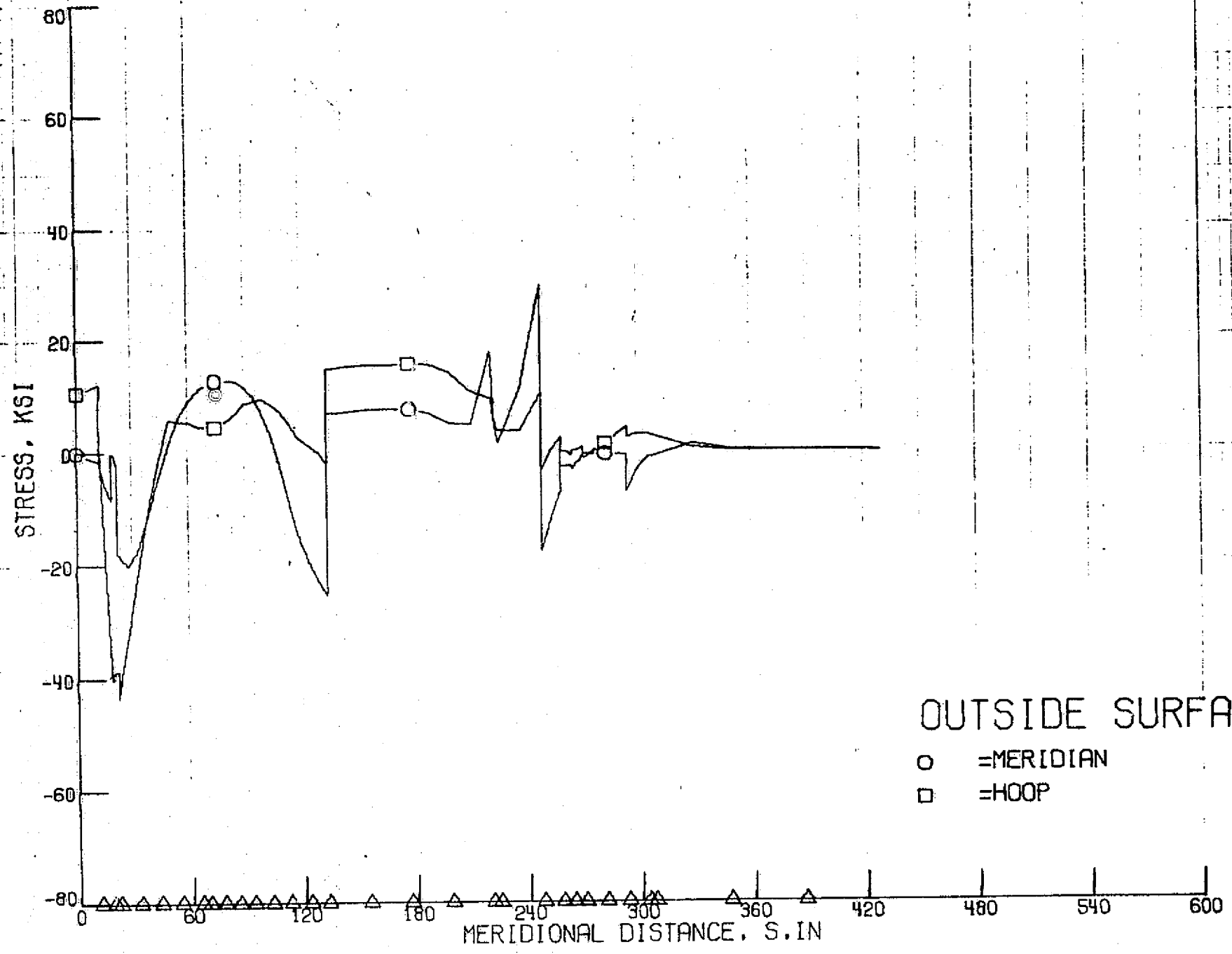

FIG 19

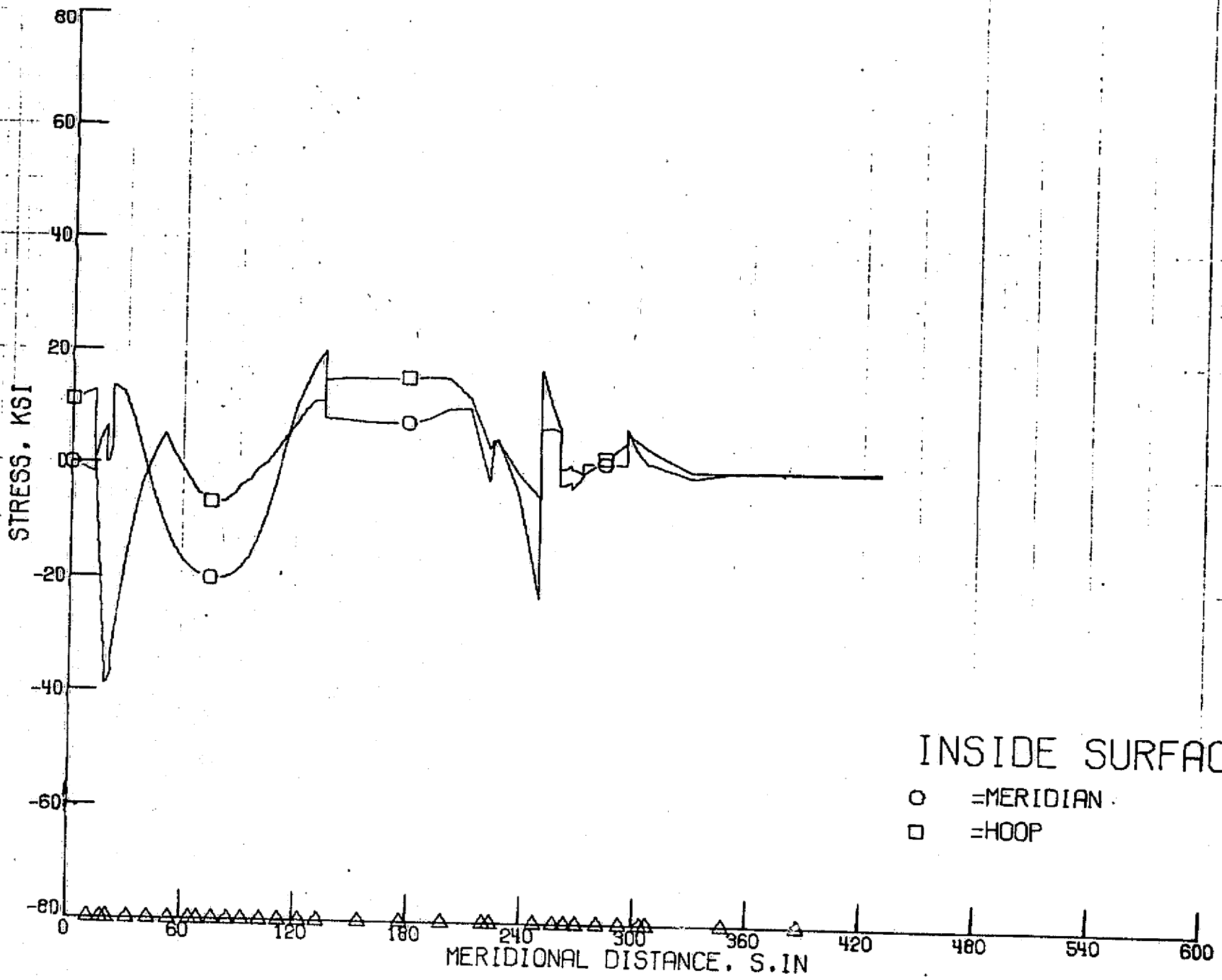

FIG. 20

1928	1887	1846	1805	1764	1723	1682	1641	1600	1559	1518	1477	1436	1395	1354	1313	1272	1231
1929	1888	1847	1806	1765	1724	1683	1642	1601	1560	1519	1478	1437	1396	1355	1314	1273	1232
1930	1889	1848	1807	1766	1725	1684	1643	1602	1561	1520	1479	1438	1397	1356	1315	1274	1233
1931	1890	1849	1808	1767	1726	1685	1644	1603	1562	1521	1480	1439	1398	1357	1316	1275	1234
1932	1891	1850	1809	1768	1727	1686	1645	1604	1563	1522	1481	1440	1399	1358	1317	1276	1235
1933	1892	1851	1810	1769	1728	1687	1646	1605	1564	1523	1482	1441	1400	1359	1318	1277	1236
1934	1893	1852	1811	1770	1729	1688	1647	1606	1565	1524	1483	1442	1401	1360	1319	1278	1237
1935	1894	1853	1812	1771	1730	1689	1648	1607	1566	1525	1484	1443	1402	1361	1320	1279	1238
1936	1895	1854	1813	1772	1731	1690	1649	1608	1567	1526	1485	1444	1403	1362	1321	1280	1239
1937	1896	1855	1814	1773	1732	1691	1650	1609	1568	1527	1486	1445	1404	1363	1322	1281	1240
1938	1897	1856	1815	1774	1733	1692	1651	1610	1569	1528	1487	1446	1405	1364	1323	1282	1241
1939	1898	1857	1816	1775	1734	1693	1652	1611	1570	1529	1488	1447	1406	1365	1324	1283	1242
1940	1899	1858	1817	1776	1735	1694	1653	1612	1571	1530	1489	1448	1407	1366	1325	1284	1243
1941	1900	1859	1818	1777	1736	1695	1654	1613	1572	1531	1490	1449	1408	1367	1326	1285	1244
1942	1901	1860	1819	1778	1737	1696	1655	1614	1573	1532	1491	1450	1409	1368	1327	1286	1245
1943	1902	1861	1820	1779	1738	1697	1656	1615	1574	1533	1492	1451	1410	1369	1328	1287	1246
1944	1903	1862	1821	1780	1739	1698	1657	1616	1575	1534	1493	1452	1411	1370	1329	1288	1247
1945	1904	1863	1822	1781	1740	1699	1658	1617	1576	1535	1494	1453	1412	1371	1330	1289	1248
1946	1905	1864	1823	1782	1741	1700	1659	1618	1577	1536	1495	1454	1413	1372	1331	1290	1249
1947	1906	1865	1824	1783	1742	1701	1660	1619	1578	1537	1496	1455	1414	1373	1332	1291	1250
1948	1907	1866	1825	1784	1743	1702	1661	1620	1579	1538	1497	1456	1415	1374	1333	1292	1251
1949	1908	1867	1826	1785	1744	1703	1662	1621	1580	1539	1498	1457	1416	1375	1334	1293	1252
1950	1909	1868	1827	1786	1745	1704	1663	1622	1581	1540	1499	1458	1417	1376	1335	1294	1253
1951	1910	1869	1828	1787	1746	1705	1664	1623	1582	1541	1500	1459	1418	1377	1336	1295	1254
1952	1911	1870	1829	1788	1747	1706	1665	1624	1583	1542	1501	1460	1419	1378	1337	1296	1255
1953	1912	1871	1830	1789	1748	1707	1666	1625	1584	1543	1502	1461	1420	1379	1338	1297	1256
1954	1913	1872	1831	1790	1749	1708	1667	1626	1585	1544	1503	1462	1421	1380	1339	1298	1257
1955	1914	1873	1832	1791	1750	1709	1668	1627	1586	1545	1504	1463	1422	1381	1340	1299	1258
1956	1915	1874	1833	1792	1751	1710	1669	1628	1587	1546	1505	1464	1423	1382	1341	1300	1259
1957	1916	1875	1834	1793	1752	1711	1670	1629	1588	1547	1506	1465	1424	1383	1342	1301	1260
1958	1917	1876	1835	1794	1753	1712	1671	1630	1589	1548	1507	1466	1425	1384	1343	1302	1261
1959	1918	1877	1836	1795	1754	1713	1672	1631	1590	1549	1508	1467	1426	1385	1344	1303	1262
1960	1919	1878	1837	1796	1755	1714	1673	1632	1591	1550	1509	1468	1427	1386	1345	1304	1263
1961	1920	1879	1838	1797	1756	1715	1674	1633	1592	1551	1510	1469	1428	1387	1346	1305	1264
1962	1921	1880	1839	1798	1757	1716	1675	1634	1593	1552	1511	1470	1429	1388	1347	1306	1265
1963	1922	1881	1840	1799	1758	1717	1676	1635	1594	1553	1512	1471	1430	1389	1348	1307	1266
1964	1923	1882	1841	1800	1759	1718	1677	1636	1595	1554	1513	1472	1431	1390	1349	1308	1267
1965	1924	1883	1842	1801	1760	1719	1678	1637	1596	1555	1514	1473	1432	1391	1350	1309	1268
1966	1925	1884	1843	1802	1761	1720	1679	1638	1597	1556	1515	1474	1433	1392	1351	1310	1269
1967	1926	1885	1844	1803	1762	1721	1680	1639	1598	1557	1516	1475	1434	1393	1352	1311	1270
1968	1927	1886	1845	1804	1763	1722	1681	1640	1599	1558	1517	1476	1435	1394	1353	1312	1271

SPEC
5.1

NTF BULKHEAD
SHELL

0 SCALE 36

ORIGINAL PAGE IS
OF POOR QUALITY

FIG. 21

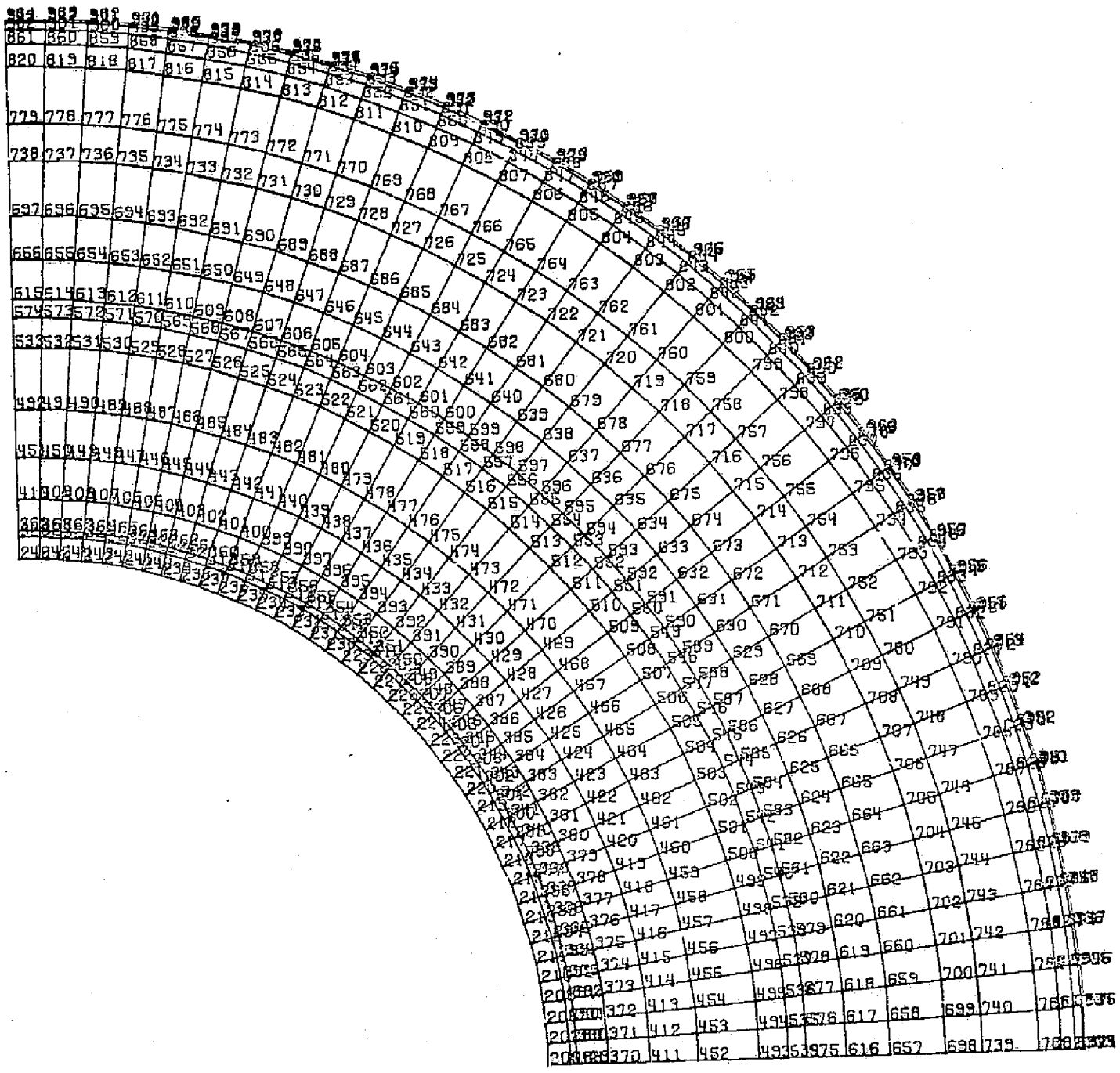

SPEC
3.1

NTF BULKHEAD
DOME

0 SCALE 2E

FIG. 22

124 2328 27 28 29 30 31 32 33 34 35 36 37 38 39 40 41 42 43 44 45 46 47 48 49 50 51 52 53 54 55 56 57 58 59 60 61 62 63 64
163 65 67 68 69 70 71 72 73 74 75 76 77 78 79 80 81 82 83 84 85 86 87 88 89 90 91 92 93 94 95 96 97 98 99 20 20 20 20 20 20
21 22 23 24 25 26 27 28 29 30 31 32 33 34 35 36 37 38 39 40 41 42 43 44 45 46 47 48 49 50 51 52 53 54 55 56 57 58 59 60 61 62 63 64
24 25 26 27 28 29 30 31 32 33 34 35 36 37 38 39 40 41 42 43 44 45 46 47 48 49 50 51 52 53 54 55 56 57 58 59 60 61 62 63 64

ORIGINAL PAGE IS
OF POOR QUALITY

SPEC
10.1

NTF BULKHEAD
HATCH OPENING

0
SCALE

FIG. 23

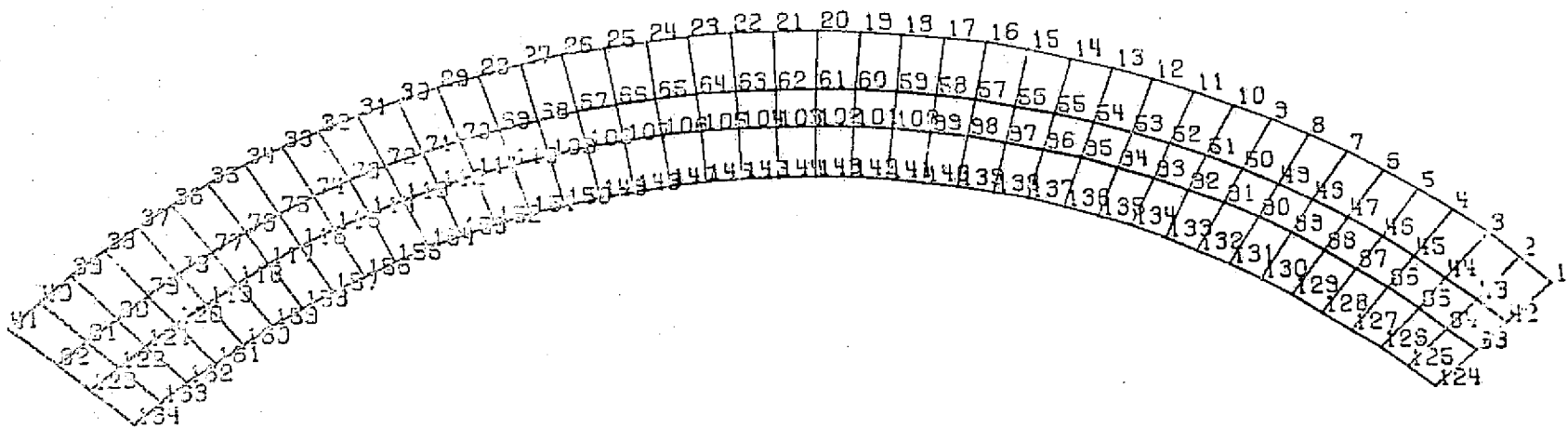

SPEC
2.1

NTF BULKHEAD
FLANGE SURFACE

0 ——— 1
SCALE

FIG 24

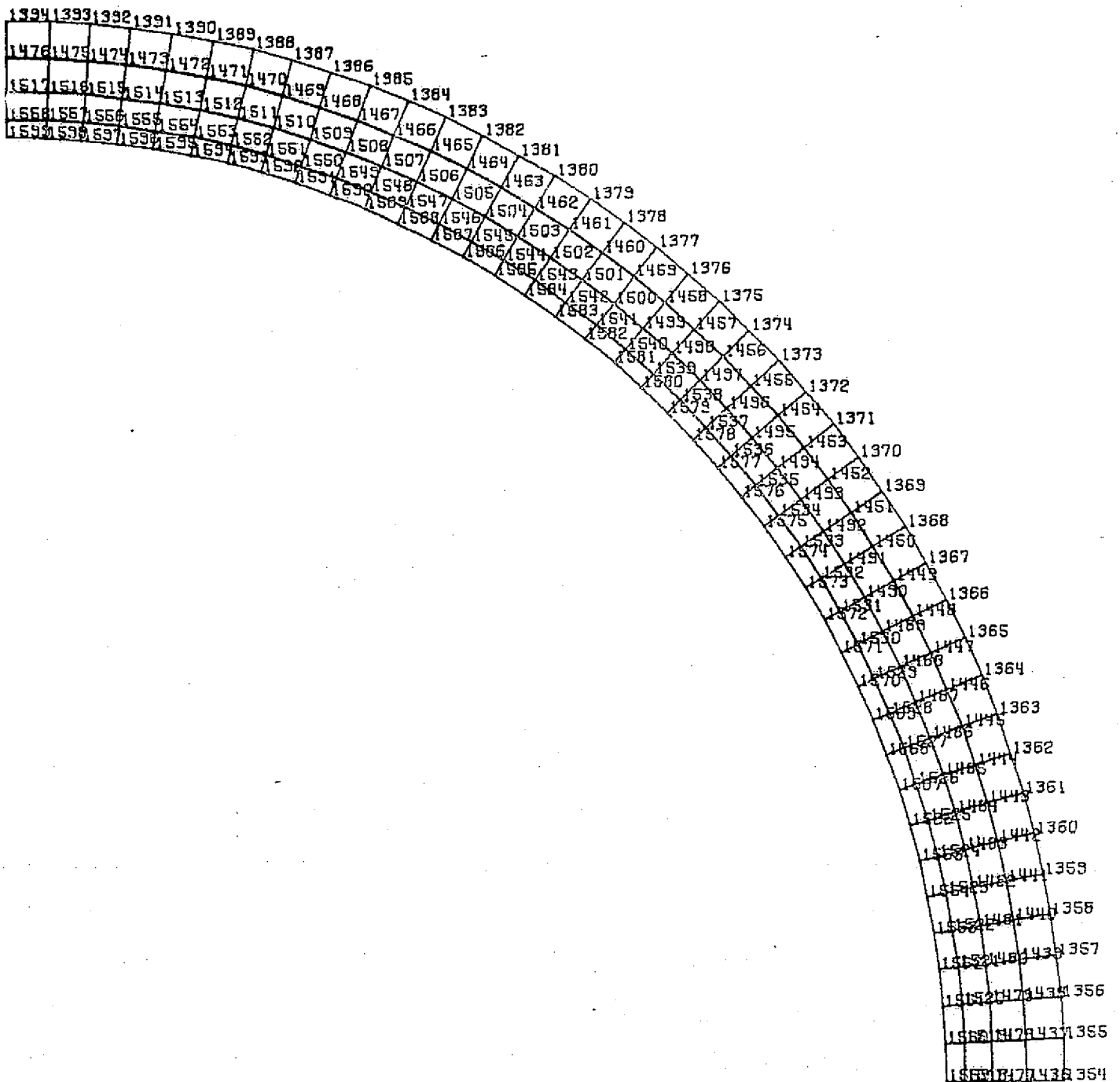

SPEC 9.1

NTF BULKHEAD WEB OF TEE

ORIGINAL PAGE IS OF POOR QUALITY.

0 SCALE 29

FIG 25

9	9	9	9	9	9	157	0	0	18	16	17	0	0	0	0
9	9	9	9	9	9	157	0	0	16	16	17	0	0	0	0
9	9	9	9	9	9	157	0	0	16	16	17	0	0	0	0
9	9	9	9	9	9	157	0	0	16	16	17	0	0	0	0
9	9	9	9	9	9	157	0	0	16	16	17	0	0	0	0
9	9	9	9	9	9	157	0	0	16	16	17	0	0	0	0
9	9	9	9	9	9	157	0	0	16	16	17	0	0	0	0
9	9	9	9	9	9	157	0	0	18	18	17	0	0	0	0
9	9	9	9	9	9	157	0	0	16	16	17	0	0	0	0
9	9	9	9	9	9	157	0	0	16	16	17	0	0	0	0
9	9	9	9	9	9	157	0	0	16	16	17	0	0	0	0
9	9	9	9	9	9	157	0	0	16	16	17	0	0	0	0
9	9	9	9	9	9	157	0	0	18	18	17	0	0	0	0
9	9	9	9	9	9	157	0	0	18	18	17	0	0	0	0
9	9	9	9	9	9	157	0	0	16	16	17	0	0	0	0
9	9	9	9	9	9	157	0	0	16	16	17	0	0	0	0
9	9	9	9	9	9	157	0	0	18	18	17	0	0	0	0
9	9	9	9	9	9	157	0	0	16	16	17	0	0	0	0
9	9	9	9	9	9	157	0	0	18	18	17	0	0	0	0
9	9	9	9	9	9	157	0	0	16	16	17	0	0	0	0
9	9	9	9	9	9	157	0	0	16	16	17	0	0	0	0
9	9	9	9	9	9	157	0	0	18	18	17	0	0	0	0
9	9	9	9	9	9	157	0	0	16	16	17	0	0	0	0
9	9	9	9	9	9	157	0	0	18	18	17	0	0	0	0
9	9	9	9	9	9	157	0	0	16	16	17	0	0	0	0
9	9	9	9	9	9	157	0	0	16	16	17	0	0	0	0
9	9	9	9	9	9	157	0	0	18	18	17	0	0	0	0
9	9	9	9	9	9	157	0	0	16	16	17	0	0	0	0
9	9	9	9	9	9	157	0	0	18	18	17	0	0	0	0
9	9	9	9	9	9	157	0	0	16	16	17	0	0	0	0
9	9	9	9	9	9	157	0	0	16	16	17	0	0	0	0
9	9	9	9	9	9	157	0	0	18	18	17	0	0	0	0
9	9	9	9	9	9	157	0	0	16	16	17	0	0	0	0
9	9	9	9	9	9	157	0	0	16	16	17	0	0	0	0
9	9	9	9	9	9	157	0	0	18	18	17	0	0	0	0
9	9	9	9	9	9	157	0	0	16	16	17	0	0	0	0
9	9	9	9	9	9	157	0	0	16	16	17	0	0	0	0
9	9	9	9	9	9	157	0	0	18	18	17	0	0	0	0
9	9	9	9	9	9	157	0	0	16	16	17	0	0	0	0
9	9	9	9	9	9	157	0	0	16	16	17	0	0	0	0
9	9	9	9	9	9	157	0	0	18	18	17	0	0	0	0
9	9	9	9	9	9	157	0	0	16	16	17	0	0	0	0

SPEC 5.1

NTF BULKHEAD SHELL

0 SCALE 36

ELEMENT SECTION PROPERTY GROUPS

FIG 20

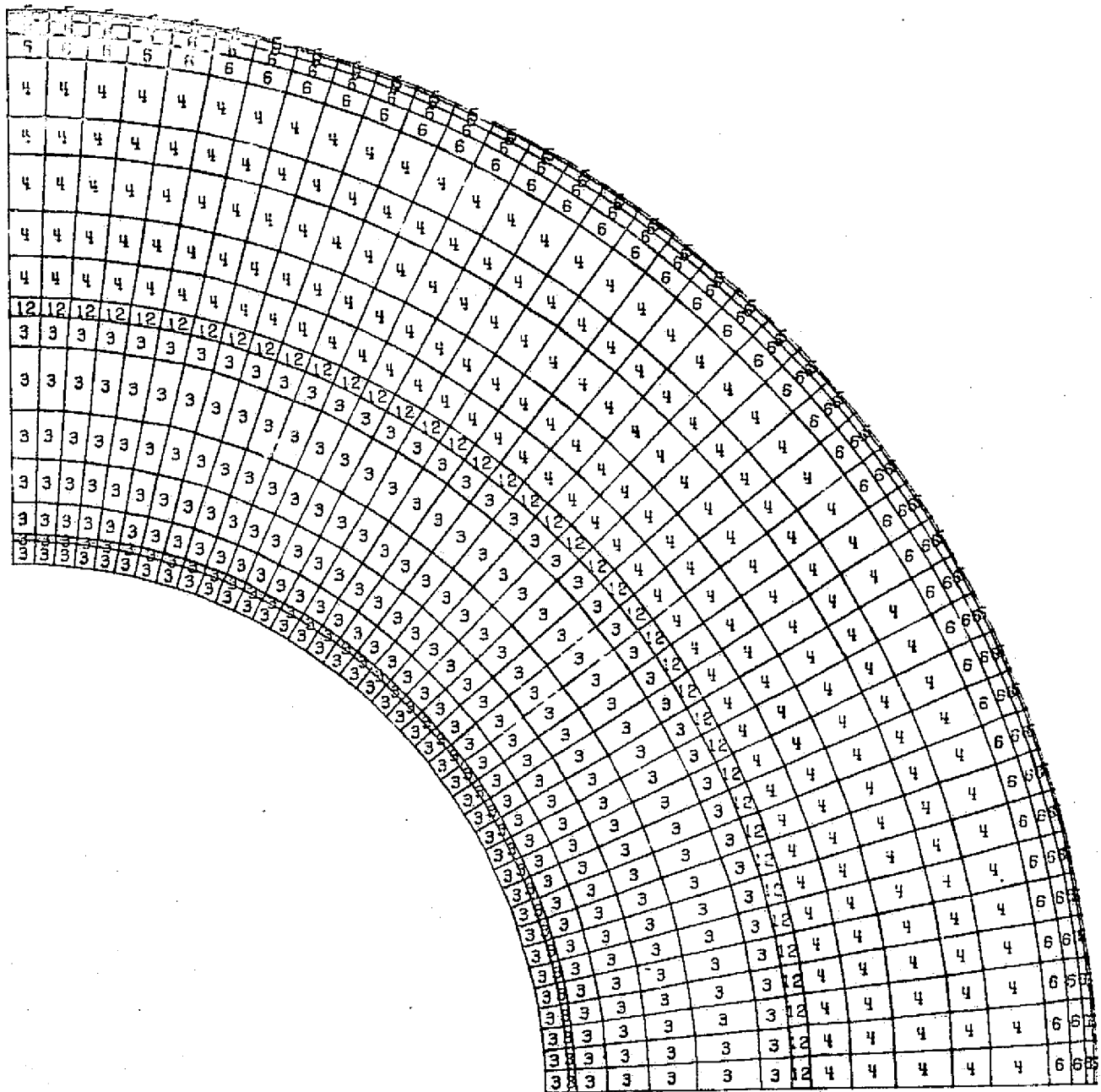

SPEC
3.1

NTF BULKHEAD
DOME

0 SCALE 2

ELEMENT SECTION PROPERTY GROUPS

ORIGINAL PAGE IS
OF POOR QUALITY

FIG 27

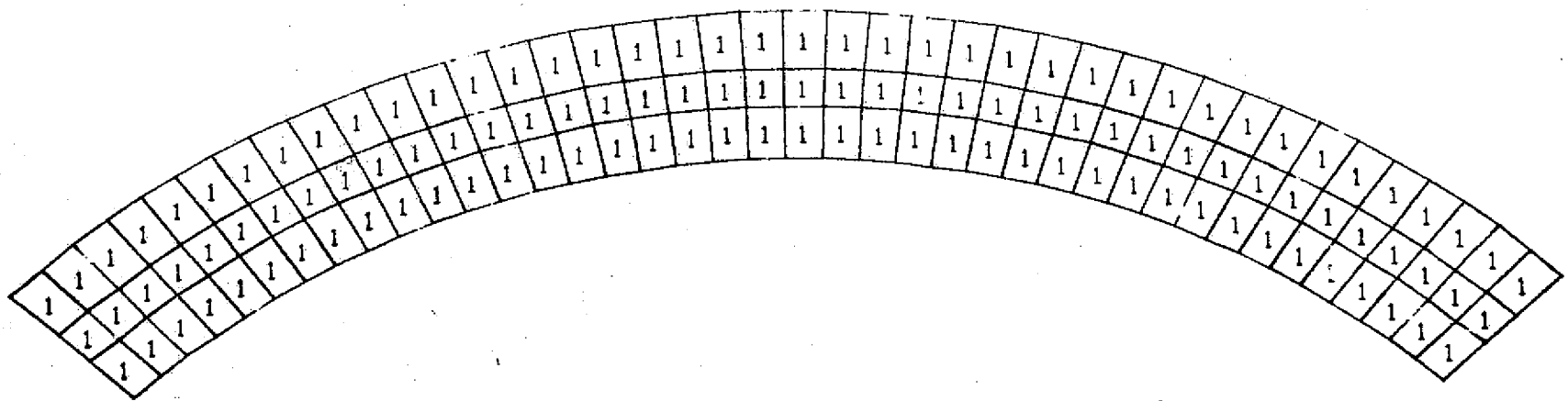

ELEMENT SECTION PROPERTY GROUPS

SPEC
2.1

NTF BULKHEAD
FLANGE SURFACE



FIG 28

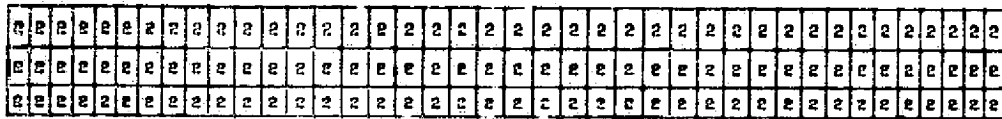

SPEC
10-1

NOTE BULKHEAD
MATCH OPENING

0 SCALE 18

ORIGINAL PAGE IS
OF POOR QUALITY

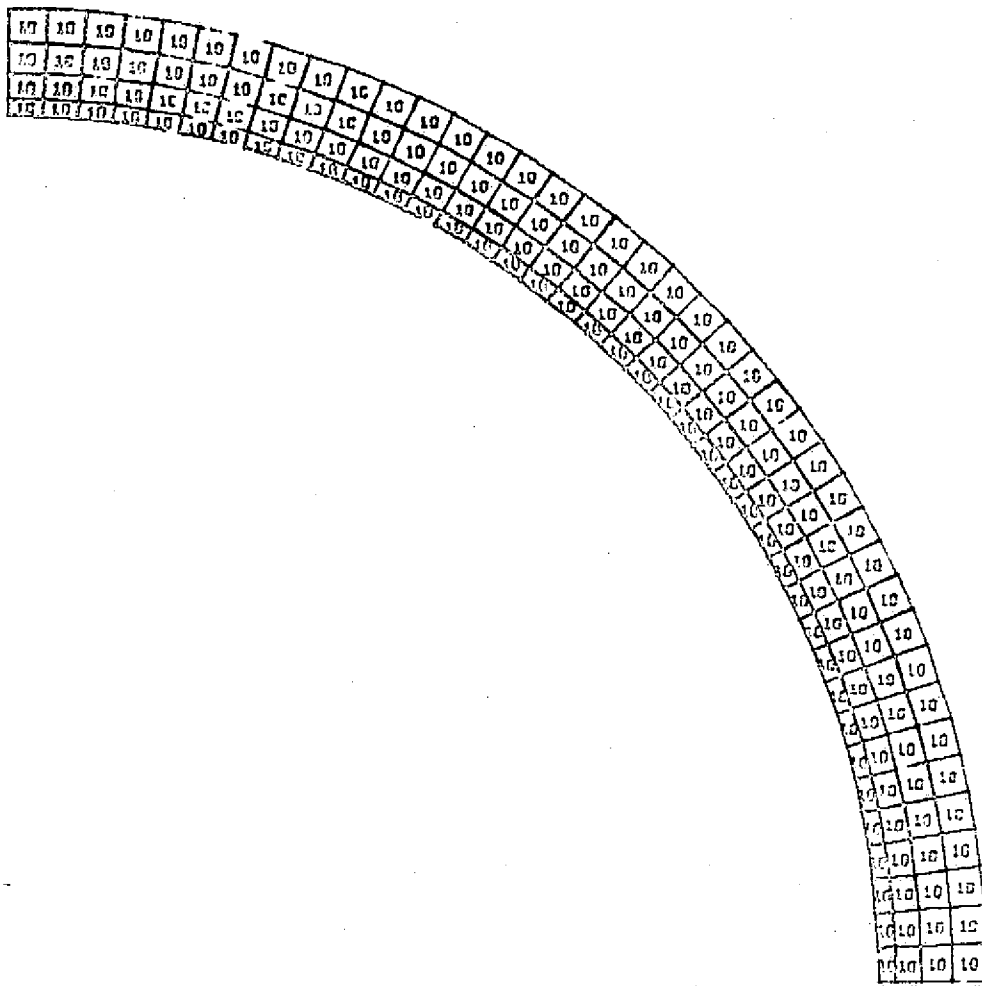

SPEC
9.1

NIE BULKHEAD
WEB OF THE

0 SCALE 29

ELEMENT POSITION PROPERTY GROUPS

FIG 30



SPIC
11-1

NTE BULKHEAD
TEE

0 11
SCALE

ORIGINAL PAGE IS
OF POOR QUALITY

11-11-11

FIG 31

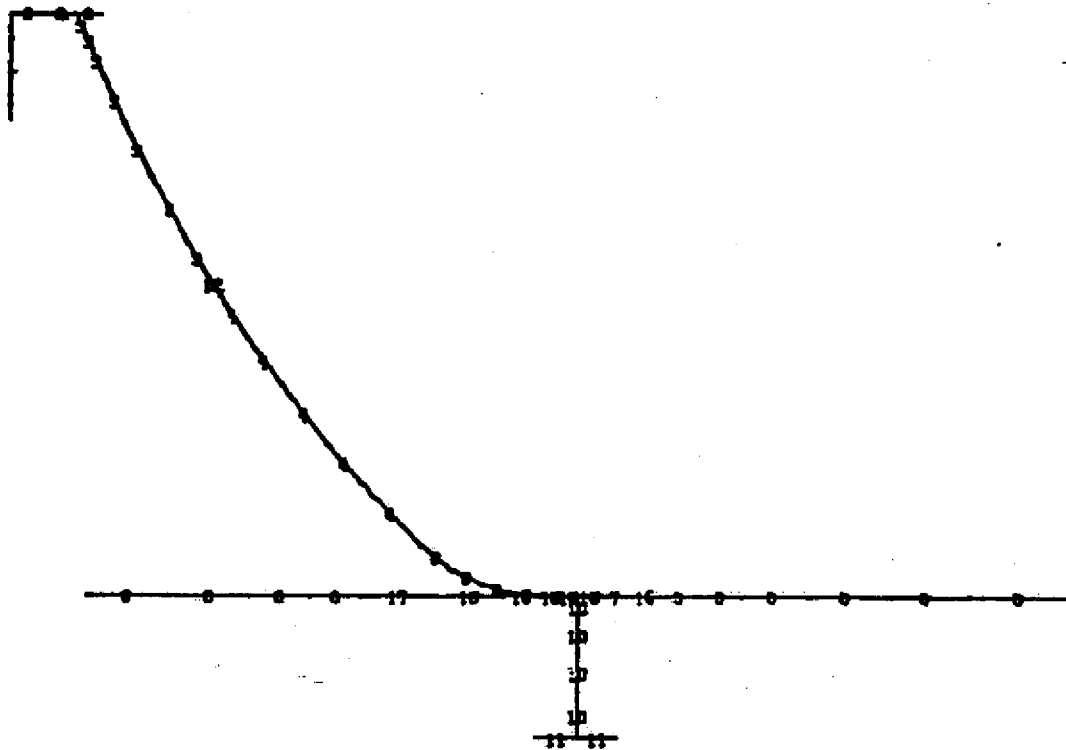

SPEC
12-1

NTF BULKHEAD
CROSS-SECTION VIEW

0 SCALE 25

FIG. 32

CLIENT SECTION PROPERTY, GROUP

CASE 1

GATE VALVE CLOSED
STRESS PLOTS

FIGURES 33 THRU 59

COMPUTER RUN NO. LAK

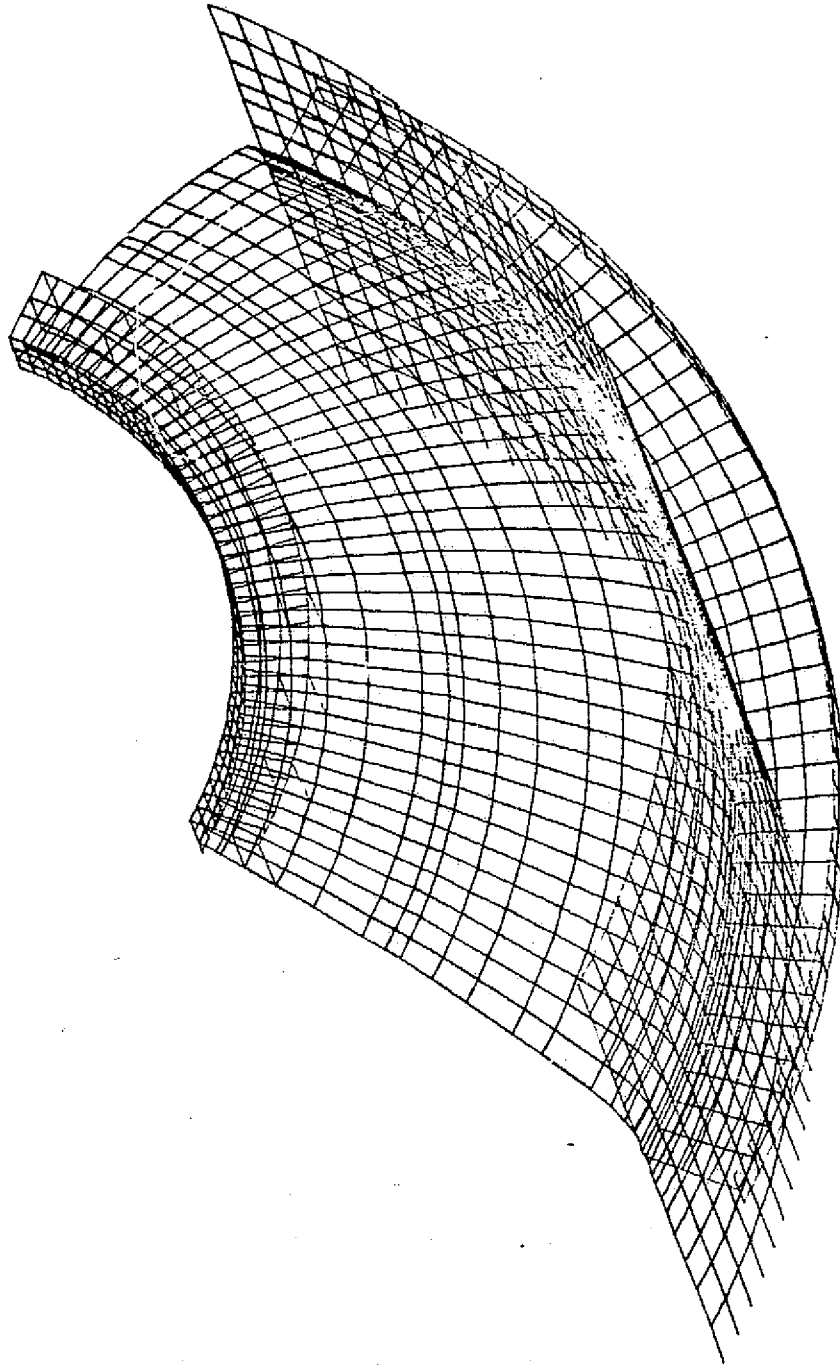

SPEC

N.T.E. BULKHEAD

0 SCALE 41

FIG. 33

DISPLAY= SX /1000 , NODE= 1, SURFACE= 0

1/1/1

0	0	0	0	1	1	2	3	4	5	6	7	9	12	14	15	16
0	0	0	0	1	1	2	3	4	5	6	7	9	12	14	15	16
0	0	0	0	1	1	2	3	4	5	6	7	9	12	14	15	16
0	0	0	0	1	1	2	3	4	5	6	7	9	12	14	15	16
0	0	0	0	1	1	2	3	4	5	6	7	9	12	14	15	16
0	0	0	0	1	1	2	3	4	5	6	7	9	12	14	15	16
0	0	0	0	1	1	2	3	4	5	6	7	9	12	14	15	16
0	0	0	0	1	1	2	3	4	5	6	7	9	12	14	15	16
0	0	0	0	1	1	2	3	4	5	6	7	9	12	14	15	16
0	0	0	0	1	1	2	3	4	5	6	7	9	12	14	15	16
0	0	0	0	1	1	2	3	4	5	6	7	9	12	14	15	16
0	0	0	0	1	1	2	3	4	5	6	7	9	12	14	15	16
0	0	0	0	1	1	2	3	4	5	6	7	9	12	14	15	16
0	0	0	0	1	1	2	3	4	5	6	7	9	12	14	15	16
0	0	0	0	1	1	2	3	4	5	6	7	9	12	14	15	16
0	0	0	0	1	1	2	3	4	5	6	7	9	12	14	15	16
0	0	0	0	1	1	2	3	4	5	6	7	9	12	14	15	16
0	0	0	0	1	1	2	3	4	5	6	7	9	12	14	15	16
0	0	0	0	1	1	2	3	4	5	6	7	9	12	14	15	16
0	0	0	0	1	1	2	3	4	5	6	7	9	12	14	15	16
0	0	0	0	1	1	2	3	4	5	6	7	9	12	14	15	16
0	0	0	0	1	1	2	3	4	5	6	7	9	12	14	15	16
0	0	0	0	1	1	2	3	4	5	6	7	9	12	14	15	16
0	0	0	0	1	1	2	3	4	5	6	7	9	12	14	15	16
0	0	0	0	1	1	2	3	4	5	6	7	9	12	14	15	16
0	0	0	0	1	1	2	3	4	5	6	7	9	12	14	15	16
0	0	0	0	1	1	2	3	4	5	6	7	9	12	14	15	16
0	0	0	0	1	1	2	3	4	5	6	7	9	12	14	15	16
0	0	0	0	1	1	2	3	4	5	6	7	9	12	14	15	16
0	0	0	0	1	1	2	3	4	5	6	7	9	12	14	15	16
0	0	0	0	1	1	2	3	4	5	6	7	9	12	14	15	16
0	0	0	0	1	1	2	3	4	5	6	7	9	12	14	15	16
0	0	0	0	1	1	2	3	4	5	6	7	9	12	14	15	16
0	0	0	0	1	1	2	3	4	5	6	7	9	12	14	15	16
0	0	0	0	1	1	2	3	4	5	6	7	9	12	14	15	16
0	0	0	0	1	1	2	3	4	5	6	7	9	12	14	15	16

SPEC
.1

NIF BULKHEAD
SHELL

0 _____ 36
SCALE

FIG 34

DISPLAY= SX /1000 , NODE= 1 , SURFACE= 1

1/1/1

0	0	0	0	1	2	3	3	4	4	3	6	7	9	12	14	16	16
0	0	0	0	1	2	3	3	4	4	3	6	7	9	12	14	16	16
0	0	0	0	1	2	3	3	4	4	3	6	7	9	12	14	16	16
0	0	0	0	1	2	3	3	4	4	3	6	7	9	12	14	16	16
0	0	0	0	1	2	3	3	4	4	3	6	7	9	12	14	16	16
0	0	0	0	1	2	3	3	4	4	3	6	7	9	12	14	16	16
0	0	0	0	1	2	3	3	4	4	3	6	7	9	12	14	16	16
0	0	0	0	1	2	3	3	4	4	3	6	7	9	12	14	16	16
0	0	0	0	1	2	3	3	4	4	3	6	7	9	12	14	16	16
0	0	0	0	1	2	3	3	4	4	3	6	7	9	12	14	16	16
0	0	0	0	1	2	3	3	4	4	3	6	7	9	12	14	16	16
0	0	0	0	1	2	3	3	4	4	3	6	7	9	12	14	16	16
0	0	0	0	1	2	3	3	4	4	3	6	7	9	12	14	16	16
0	0	0	0	1	2	3	3	4	4	3	6	7	9	12	14	16	16
0	0	0	0	1	2	3	3	4	4	3	6	7	9	12	14	16	16
0	0	0	0	1	2	3	3	4	4	3	6	7	9	12	14	16	16
0	0	0	0	1	2	3	3	4	4	3	6	7	9	12	14	16	16
0	0	0	0	1	2	3	3	4	4	3	6	7	9	12	14	16	16
0	0	0	0	1	2	3	3	4	4	3	6	7	9	12	14	16	16
0	0	0	0	1	2	3	3	4	4	3	6	7	9	12	14	16	16
0	0	0	0	1	2	3	3	4	4	3	6	7	9	12	14	16	16
0	0	0	0	1	2	3	3	4	4	3	6	7	9	12	14	16	16
0	0	0	0	1	2	3	3	4	4	3	6	7	9	12	14	16	16
0	0	0	0	1	2	3	3	4	4	3	6	7	9	12	14	16	16
0	0	0	0	1	2	3	3	4	4	3	6	7	9	12	14	16	16
0	0	0	0	1	2	3	3	4	4	3	6	7	9	12	14	16	16
0	0	0	0	1	2	3	3	4	4	3	6	7	9	12	14	16	16
0	0	0	0	1	2	3	3	4	4	3	6	7	9	12	14	16	16
0	0	0	0	1	2	3	3	4	4	3	6	7	9	12	14	16	16
0	0	0	0	1	2	3	3	4	4	3	6	7	9	12	14	16	16

SPEC .1

NIF BULKHEAD SHELL

0 SCALE 36

ORIGINAL PAGE IS OF POOR QUALITY

FIG. 35

1/1/1

DISPLAY= SX /1000 , NODE= 1 , SURFACE= 2

0	0	0	0	0	1	2	3	4	6	7	6	7	10	12	13	15	16
0	0	0	0	0	1	2	3	4	6	7	6	7	10	12	13	15	16
0	0	0	0	0	1	2	3	4	6	7	6	7	10	12	13	15	16
0	0	0	0	0	1	2	3	4	6	7	6	7	10	12	13	15	16
0	0	0	0	0	1	2	3	4	6	7	6	7	10	12	13	15	16
0	0	0	0	0	1	2	3	4	6	7	6	7	10	12	13	15	16
0	0	0	0	0	1	2	3	4	6	7	6	7	10	12	13	15	16
0	0	0	0	0	1	2	3	4	6	7	6	7	10	12	13	15	16
0	0	0	0	0	1	2	3	4	6	7	6	7	10	12	13	15	16
0	0	0	0	0	1	2	3	4	6	7	6	7	10	12	13	15	16
0	0	0	0	0	1	2	3	4	6	7	6	7	10	12	13	15	16
0	0	0	0	0	1	2	3	4	6	7	6	7	10	12	13	15	16
0	0	0	0	0	1	2	3	4	6	7	6	7	10	12	13	15	16
0	0	0	0	0	1	2	3	4	6	7	6	7	10	12	13	15	16
0	0	0	0	0	1	2	3	4	6	7	6	7	10	12	13	15	16
0	0	0	0	0	1	2	3	4	6	7	6	7	10	12	13	15	16
0	0	0	0	0	1	2	3	4	6	7	6	7	10	12	13	15	16
0	0	0	0	0	1	2	3	4	6	7	6	7	10	12	13	15	16
0	0	0	0	0	1	2	3	4	6	7	6	7	10	12	13	15	16
0	0	0	0	0	1	2	3	4	6	7	6	7	10	12	13	15	16
0	0	0	0	0	1	2	3	4	6	7	6	7	10	12	13	15	16
0	0	0	0	0	1	2	3	4	6	7	6	7	10	12	13	15	16
0	0	0	0	0	1	2	3	4	6	7	6	7	10	12	13	15	16
0	0	0	0	0	1	2	3	4	6	7	6	7	10	12	13	15	16
0	0	0	0	0	1	2	3	4	6	7	6	7	10	12	13	15	16
0	0	0	0	0	1	2	3	4	6	7	6	7	10	12	13	15	16
0	0	0	0	0	1	2	3	4	6	7	6	7	10	12	13	15	16
0	0	0	0	0	1	2	3	4	6	7	6	7	10	12	13	15	16
0	0	0	0	0	1	2	3	4	6	7	6	7	10	12	13	15	16
0	0	0	0	0	1	2	3	4	6	7	6	7	10	12	13	15	16
0	0	0	0	0	1	2	3	4	6	7	6	7	10	12	13	15	16
0	0	0	0	0	1	2	3	4	6	7	6	7	10	12	13	15	16
0	0	0	0	0	1	2	3	4	6	7	6	7	10	12	13	15	16

SPEC
5.1

NTF BULKHEAD
SHELL

0 SCALE 36

FIG. 36

1/1/1

DISPLAY= SY /1000 , NODE= 1, SURFACE= 0

0	0	0	0	0	0	0	0	0	0	0	3	3	5	8	8	8	8
0	0	0	0	0	0	0	0	0	0	0	3	3	5	8	8	8	8
0	0	0	0	0	0	0	0	0	0	0	3	3	5	8	8	8	8
0	0	0	0	0	0	0	0	0	0	0	3	3	5	8	8	8	8
0	0	0	0	0	0	0	0	0	0	0	3	3	5	8	8	8	8
0	0	0	0	0	0	0	0	0	0	0	3	3	5	8	8	8	8
0	0	0	0	0	0	0	0	0	0	0	3	3	5	8	8	8	8
0	0	0	0	0	0	0	0	0	0	0	3	3	5	8	8	8	8
0	0	0	0	0	0	0	0	0	0	0	3	3	5	8	8	8	8
0	0	0	0	0	0	0	0	0	0	0	3	3	5	8	8	8	8
0	0	0	0	0	0	0	0	0	0	0	3	3	5	8	8	8	8
0	0	0	0	0	0	0	0	0	0	0	3	3	5	8	8	8	8
0	0	0	0	0	0	0	0	0	0	0	3	3	5	8	8	8	8
0	0	0	0	0	0	0	0	0	0	0	3	3	5	8	8	8	8
0	0	0	0	0	0	0	0	0	0	0	3	3	5	8	8	8	8
0	0	0	0	0	0	0	0	0	0	0	3	3	5	8	8	8	8
0	0	0	0	0	0	0	0	0	0	0	3	3	5	8	8	8	8
0	0	0	0	0	0	0	0	0	0	0	3	3	5	8	8	8	8
0	0	0	0	0	0	0	0	0	0	0	3	3	5	8	8	8	8
0	0	0	0	0	0	0	0	0	0	0	3	3	5	8	8	8	8
0	0	0	0	0	0	0	0	0	0	0	3	3	5	8	8	8	8
0	0	0	0	0	0	0	0	0	0	0	3	3	5	8	8	8	8
0	0	0	0	0	0	0	0	0	0	0	3	3	5	8	8	8	8
0	0	0	0	0	0	0	0	0	0	0	3	3	5	8	8	8	8
0	0	0	0	0	0	0	0	0	0	0	3	3	5	8	8	8	8
0	0	0	0	0	0	0	0	0	0	0	3	3	5	8	8	8	8
0	0	0	0	0	0	0	0	0	0	0	3	3	5	8	8	8	8
0	0	0	0	0	0	0	0	0	0	0	3	3	5	8	8	8	8
0	0	0	0	0	0	0	0	0	0	0	3	3	5	8	8	8	8
0	0	0	0	0	0	0	0	0	0	0	3	3	5	8	8	8	8
0	0	0	0	0	0	0	0	0	0	0	3	3	5	8	8	8	8
0	0	0	0	0	0	0	0	0	0	0	3	3	5	8	8	8	8
0	0	0	0	0	0	0	0	0	0	0	3	3	5	8	8	8	8
0	0	0	0	0	0	0	0	0	0	0	3	3	5	8	8	8	8
0	0	0	0	0	0	0	0	0	0	0	3	3	5	8	8	8	8
0	0	0	0	0	0	0	0	0	0	0	3	3	5	8	8	8	8
0	0	0	0	0	0	0	0	0	0	0	3	3	5	8	8	8	8
0	0	0	0	0	0	0	0	0	0	0	3	3	5	8	8	8	8
0	0	0	0	0	0	0	0	0	0	0	3	3	5	8	8	8	8

SPEC 5.1

NTF BULKHEAD SHELL

0 SCALE 36

ORIGINAL PAGE IS OF POOR QUALITY

FIG. 37

DISPLAY= SY /1000 , NODE= 1 , SURFACE= 1

0	0	1	1	2	2	1	0	1	4	7	3	3	3	7	9	9	8
0	0	1	1	2	2	1	0	1	4	7	3	3	3	7	9	9	8
0	0	1	1	2	2	1	0	1	4	7	3	3	3	7	9	9	8
0	0	1	1	2	2	1	0	1	4	7	3	3	3	7	9	9	8
0	0	1	1	2	2	1	0	1	4	7	3	3	3	7	9	9	8
0	0	1	1	2	2	1	0	1	4	7	3	3	3	7	9	9	8
0	0	1	1	2	2	1	0	1	4	7	3	3	3	7	9	9	8
0	0	1	1	2	2	1	0	1	4	7	3	3	3	7	9	9	8
0	0	1	1	2	2	1	0	1	4	7	3	3	3	7	9	9	8
0	0	1	1	2	2	1	0	1	4	7	3	3	3	7	9	9	8
0	0	1	1	2	2	1	0	1	4	7	3	3	3	7	9	9	8
0	0	1	1	2	2	1	0	1	4	7	3	3	3	7	9	9	8
0	0	1	1	2	2	1	0	1	4	7	3	3	3	7	9	9	8
0	0	1	1	2	2	1	0	1	4	7	3	3	3	7	9	9	8
0	0	1	1	2	2	1	0	1	4	7	3	3	3	7	9	9	8
0	0	1	1	2	2	1	0	1	4	7	3	3	3	7	9	9	8
0	0	1	1	2	2	1	0	1	4	7	3	3	3	7	9	9	8
0	0	1	1	2	2	1	0	1	4	7	3	3	3	7	9	9	8
0	0	1	1	2	2	1	0	1	4	7	3	3	3	7	9	9	8
0	0	1	1	2	2	1	0	1	4	7	3	3	3	7	9	9	8
0	0	1	1	2	2	1	0	1	4	7	3	3	3	7	9	9	8
0	0	1	1	2	2	1	0	1	4	7	3	3	3	7	9	9	8
0	0	1	1	2	2	1	0	1	4	7	3	3	3	7	9	9	8
0	0	1	1	2	2	1	0	1	4	7	3	3	3	7	9	9	8
0	0	1	1	2	2	1	0	1	4	7	3	3	3	7	9	9	8
0	0	1	1	2	2	1	0	1	4	7	3	3	3	7	9	9	8
0	0	1	1	2	2	1	0	1	4	7	3	3	3	7	9	9	8
0	0	1	1	2	2	1	0	1	4	7	3	3	3	7	9	9	8
0	0	1	1	2	2	1	0	1	4	7	3	3	3	7	9	9	8
0	0	1	1	2	2	1	0	1	4	7	3	3	3	7	9	9	8
0	0	1	1	2	2	1	0	1	4	7	3	3	3	7	9	9	8
0	0	1	1	2	2	1	0	1	4	7	3	3	3	7	9	9	8
0	0	1	1	2	2	1	0	1	4	7	3	3	3	7	9	9	8
0	0	1	1	2	2	1	0	1	4	7	3	3	3	7	9	9	8

SPEC 5.1

NTF BULKHEAD SHELL

Q SCALE 36

FIG. 38

DISPLAY= SY /1000 , NODE= 1, SURFACE= 2

0	0	-1	-2	-2	-2	-1	0	1	4	7	3	4	6	9	6	6	7
0	0	-1	-2	-2	-2	-1	0	1	4	7	3	4	6	9	6	6	7
0	0	-1	-2	-2	-2	-1	0	1	4	7	3	4	6	9	6	6	7
0	0	-1	-2	-2	-2	-1	0	1	4	7	3	4	6	9	6	6	7
0	0	-1	-2	-2	-2	-1	0	1	4	7	3	4	6	9	6	6	7
0	0	-1	-2	-2	-2	-1	0	1	4	7	3	4	6	9	6	6	7
0	0	-1	-2	-2	-2	-1	0	1	4	7	3	4	6	9	6	6	7
0	0	-1	-2	-2	-2	-1	0	1	4	7	3	4	6	9	6	6	7
0	0	-1	-2	-2	-2	-1	0	1	4	7	3	4	6	9	6	6	7
0	0	-1	-2	-2	-2	-1	0	1	4	7	3	4	6	9	6	6	7
0	0	-1	-2	-2	-2	-1	0	1	4	7	3	4	6	9	6	6	7
0	0	-1	-2	-2	-2	-1	0	1	4	7	3	4	6	9	6	6	7
0	0	-1	-2	-2	-2	-1	0	1	4	7	3	4	6	9	6	6	7
0	0	-1	-2	-2	-2	-1	0	1	4	7	3	4	6	9	6	6	7
0	0	-1	-2	-2	-2	-1	0	1	4	7	3	4	6	9	6	6	7
0	0	-1	-2	-2	-2	-1	0	1	4	7	3	4	6	9	6	6	7
0	0	-1	-2	-2	-2	-1	0	1	4	7	3	4	6	9	6	6	7
0	0	-1	-2	-2	-2	-1	0	1	4	7	3	4	6	9	6	6	7
0	0	-1	-2	-2	-2	-1	0	1	4	7	3	4	6	9	6	6	7
0	0	-1	-2	-2	-2	-1	0	1	4	7	3	4	6	9	6	6	7
0	0	-1	-2	-2	-2	-1	0	1	4	7	3	4	6	9	6	6	7
0	0	-1	-2	-2	-2	-1	0	1	4	7	3	4	6	9	6	6	7
0	0	-1	-2	-2	-2	-1	0	1	4	7	3	4	6	9	6	6	7
0	0	-1	-2	-2	-2	-1	0	1	4	7	3	4	6	9	6	6	7
0	0	-1	-2	-2	-2	-1	0	1	4	7	3	4	6	9	6	6	7
0	0	-1	-2	-2	-2	-1	0	1	4	7	3	4	6	9	6	6	7
0	0	-1	-2	-2	-2	-1	0	1	4	7	3	4	6	9	6	6	7
0	0	-1	-2	-2	-2	-1	0	1	4	7	3	4	6	9	6	6	7
0	0	-1	-2	-2	-2	-1	0	1	4	7	3	4	6	9	6	6	7
0	0	-1	-2	-2	-2	-1	0	1	4	7	3	4	6	9	6	6	7
0	0	-1	-2	-2	-2	-1	0	1	4	7	3	4	6	9	6	6	7
0	0	-1	-2	-2	-2	-1	0	1	4	7	3	4	6	9	6	6	7

SPEC
5.1

NTF BULKHEAD
SHELL

0 _____ 36
SCALE

ORIGINAL PAGE IS
OF POOR QUALITY

DISPLAY= SX /1000 , NODE= 1 , SURFACE= 0

1/1/1

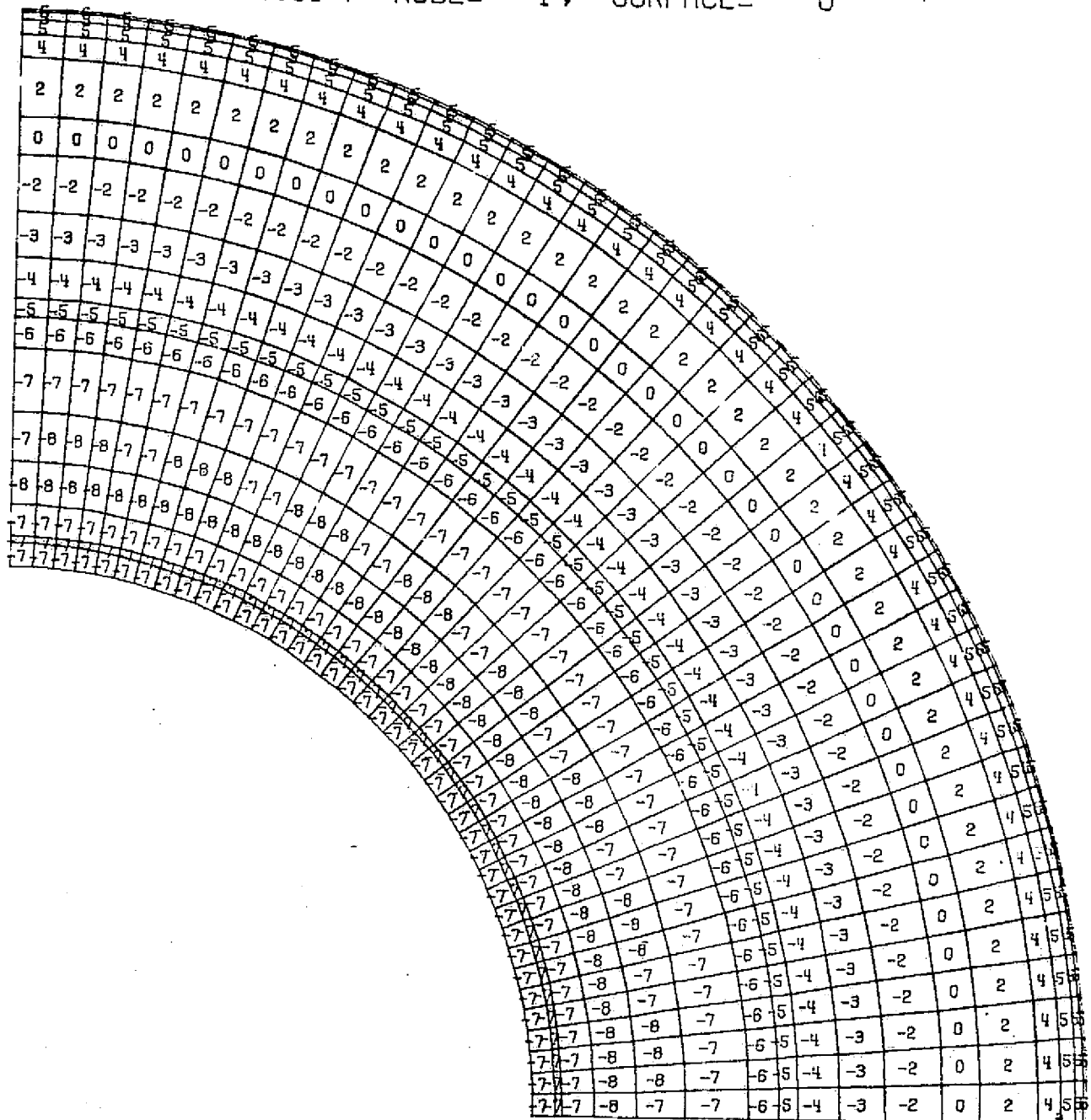

SPEC
3.1

NTF BULKHEAD
DOME

0 SCALE 26

FIG 40

1/1/1

DISPLAY= SX /1000 , NODE= 1 , SURFACE= 1

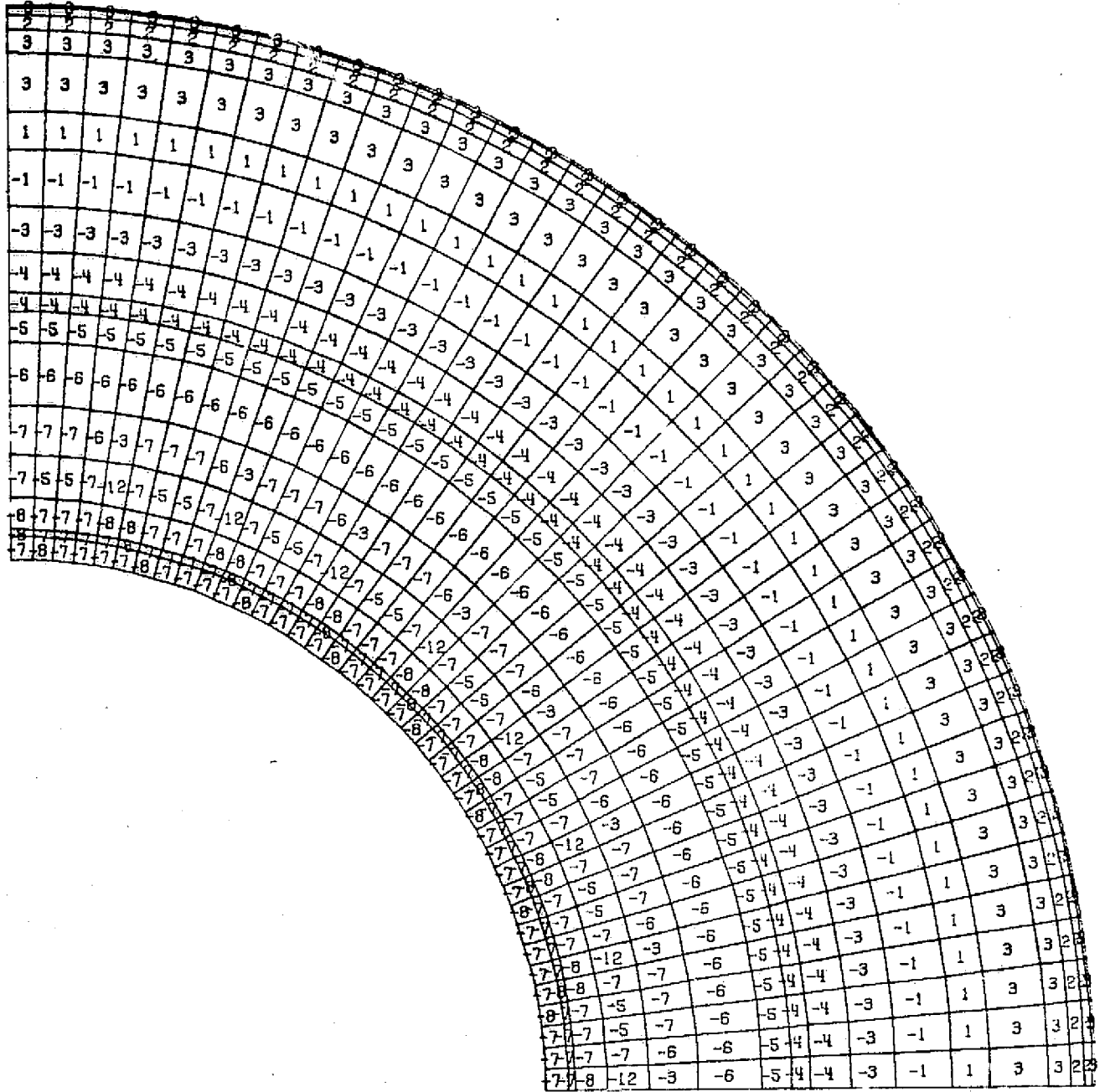

SPEC
3.1

NTF BULKHEAD
DOME

0 SCALE 26

ORIGINAL PAGE IS
OF POOR QUALITY

FIG 41

1/1/1

DISPLAY= SX /1000 , NODE= 1 , SURFACE= 2

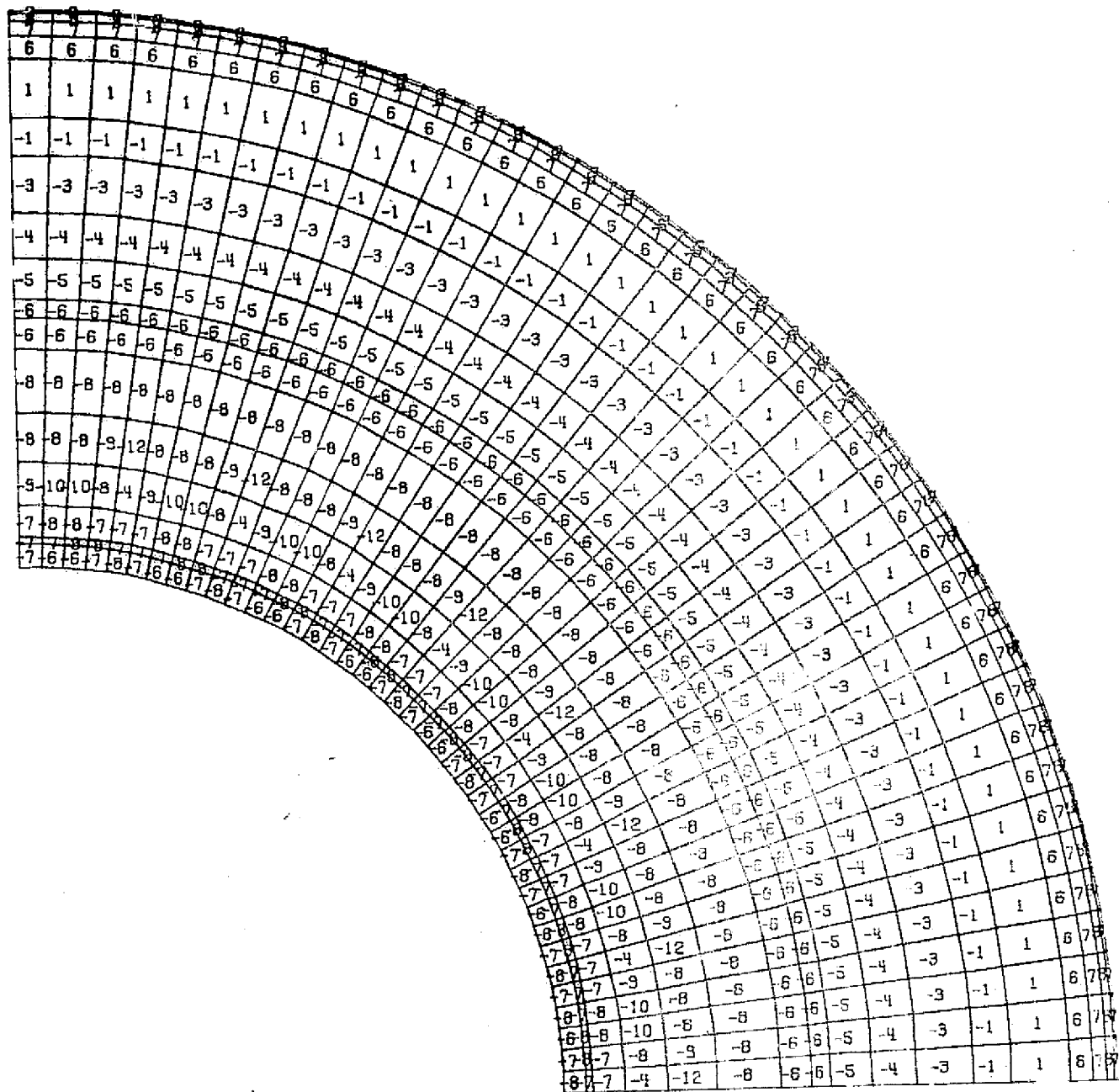

SPEC
3.1

NTF_BULKHEAD
DOME

0 SCALE 26

FIG 42

DISPLAY= SY /1000 , NODE= 1, SURFACE= 0

1/1/1

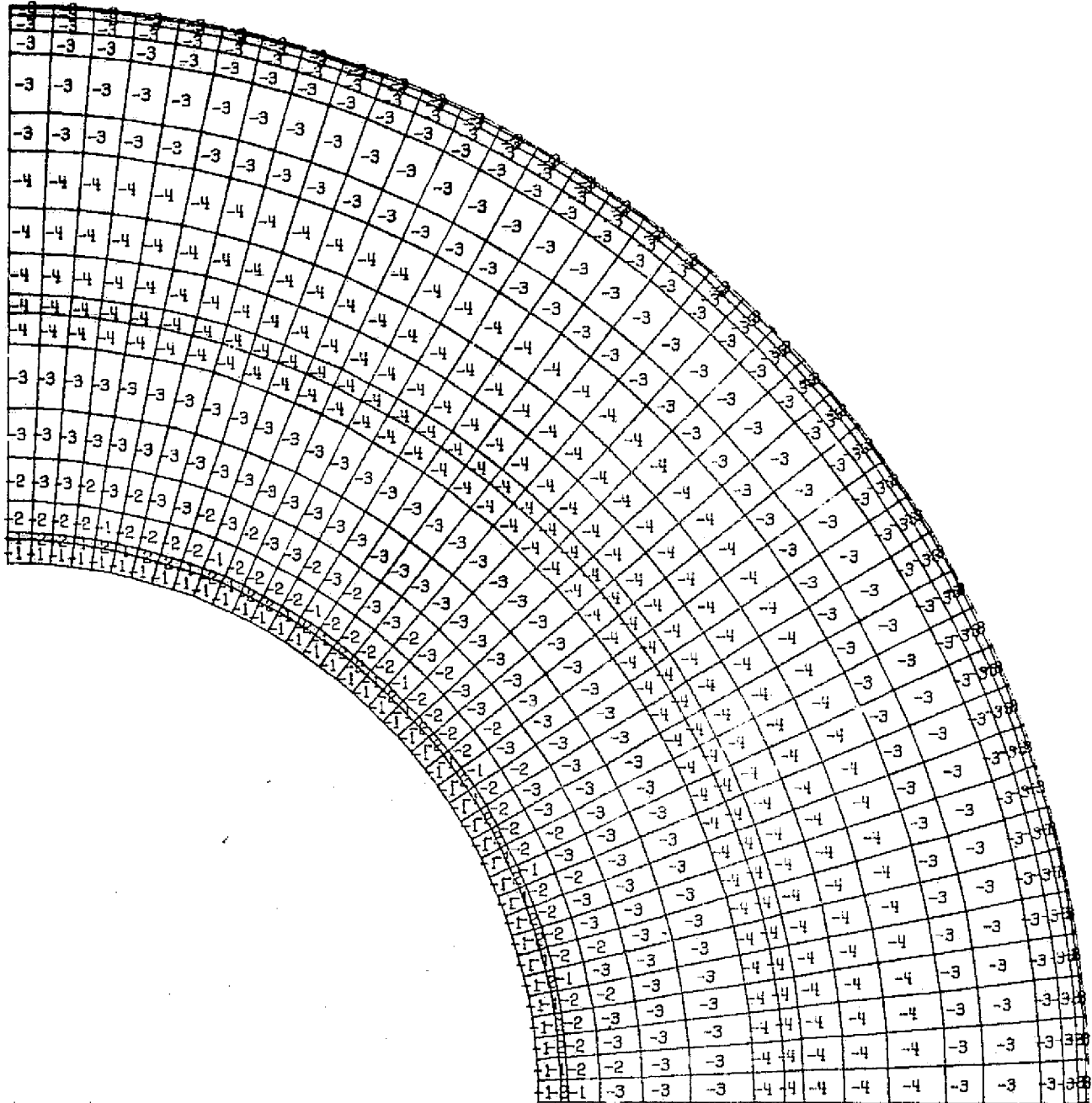

SPEC
3.1

NTF_BULKHEAD
DOME

0 SCALE 26

FIG 43

1/1/1

DISPLAY= SY /1000 , NODE= 1 , SURFACE= 1

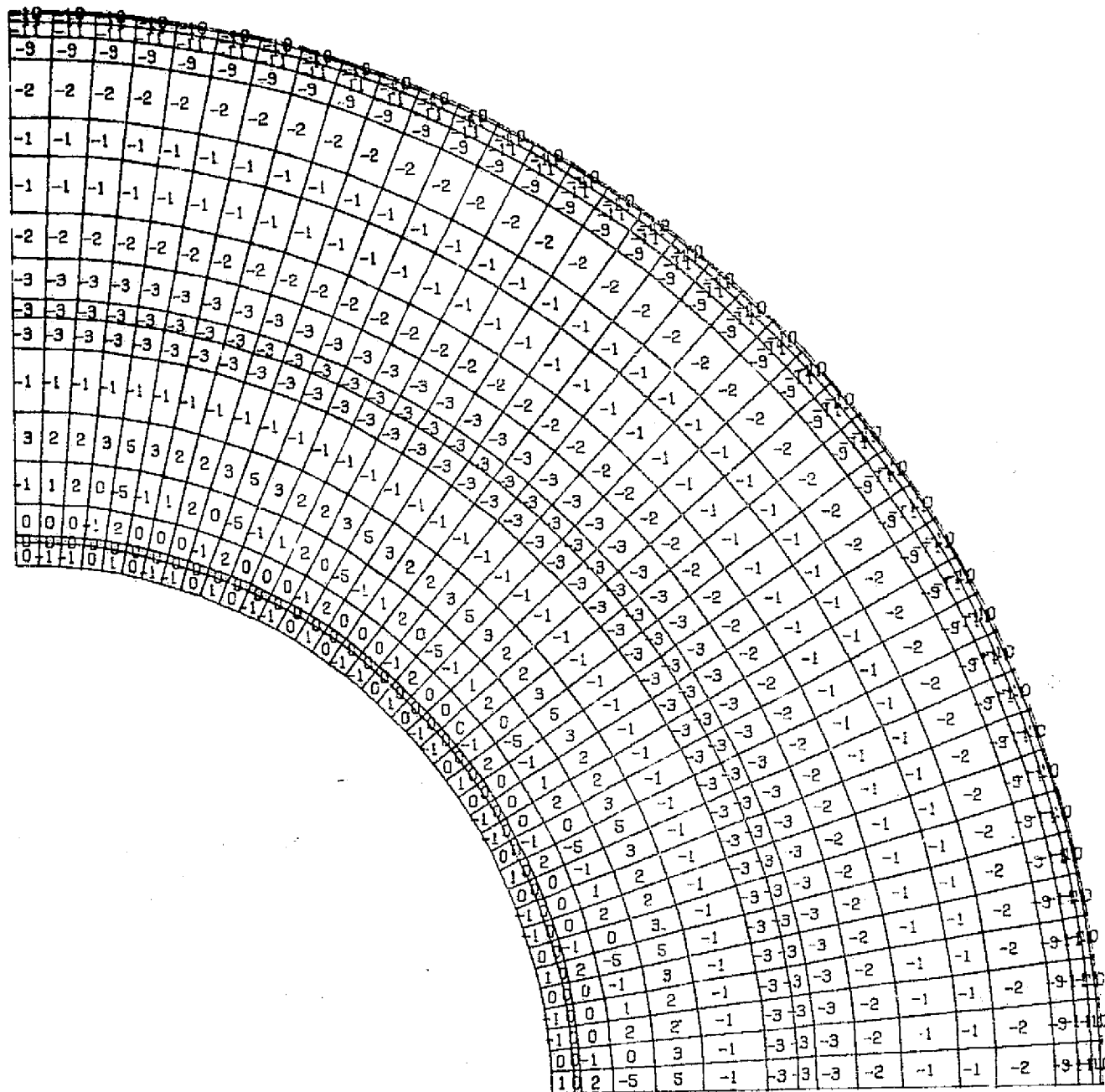

SPEC
3.1

NTF BULKHEAD
DOME

Q SCALE 26

FIG 44

DISPLAY= SY /1000 , NODE= 1, SURFACE= 2

1/1/1

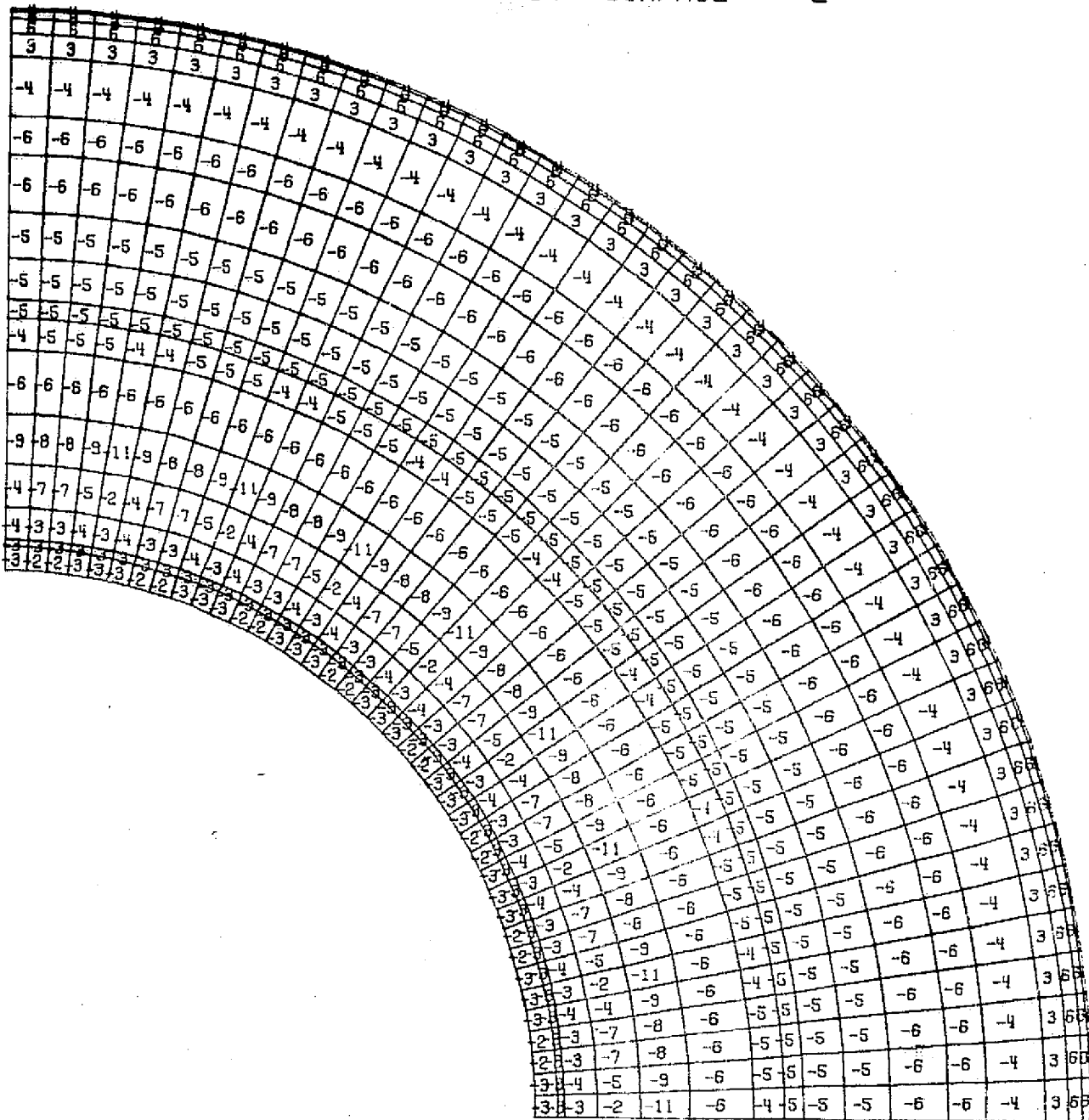

SPEC
3.1

NTF BULKHEAD
DOME

0 SCALE 26

ORIGINAL PAGE IS
OF POOR QUALITY

FIG 45

DISPLAY= SX /1000 , NODE= 1, SURFACE= 0

1/1/1

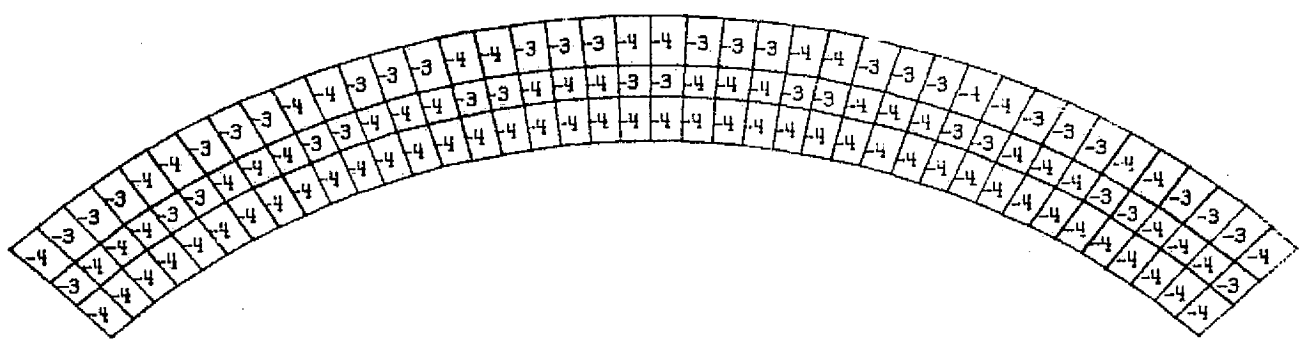

SPEC
2.1

NTF BULKHEAD
FLANGE SURFACE

0 SCALE 21

FIG 46

1/1/1

DISPLAY= SX /1000 , NODE= 1 , SURFACE= 1

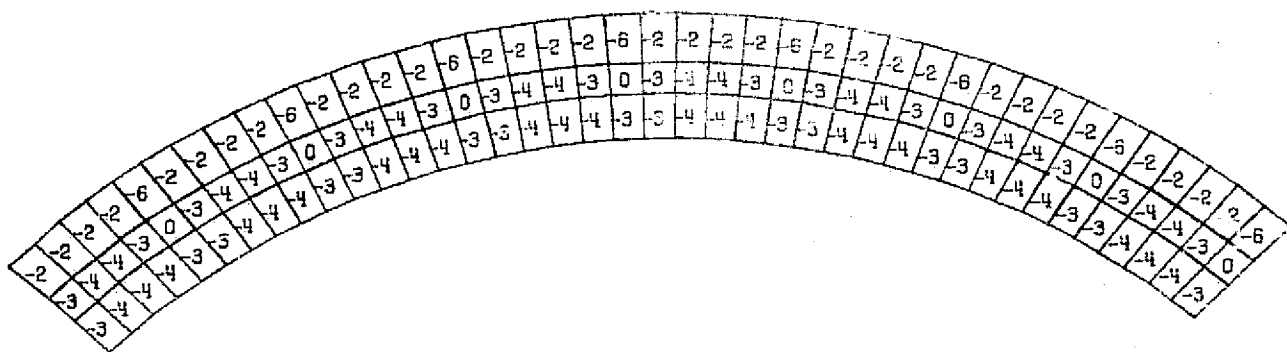

ORIGINAL PAGE IS
OF POOR QUALITY

SPEC
2.1

NTF BULKHEAD
FLANGE SURFACE

0 ———— 21
SCALE

FIG 47

DISPLAY= SX /1000 , NODE= 1 , SURFACE= 2

1/1/1

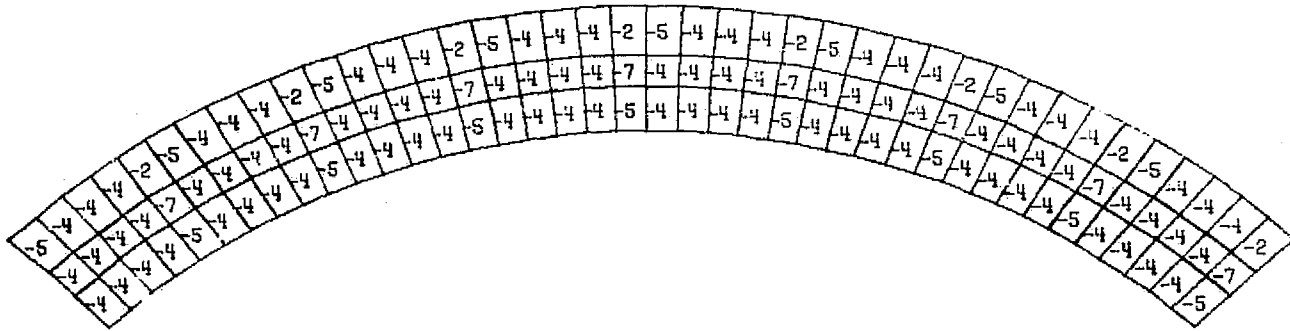

SPEC
2.1

NTF BULKHEAD
FLANGE SURFACE

0 ——— 21
SCALE

FIG 4B

DISPLAY= SY /1000 , NODE= 1, SURFACE= 0

1/1/1

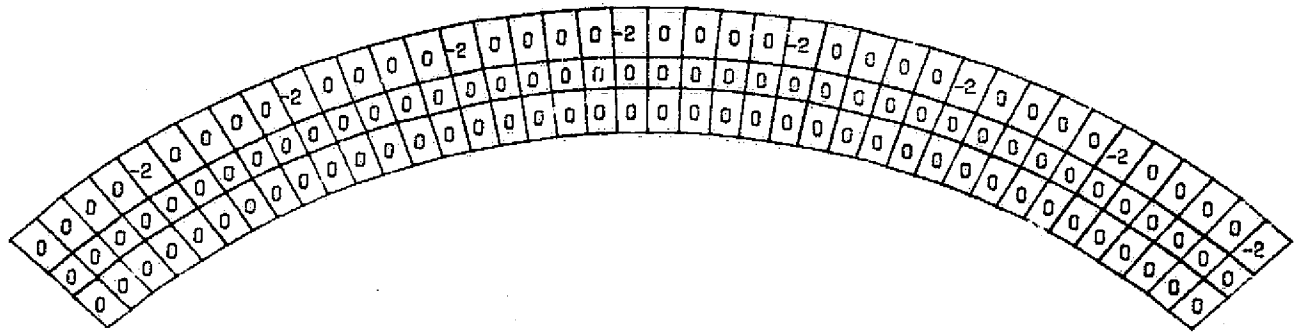

SPEC
1

NTF BULKHEAD
FLANGE SURFACE

0  21
SCALE

FIG 49

DISPLAY= SY /1000 , NODE= 1 , SURFACE= 2

1/1/1

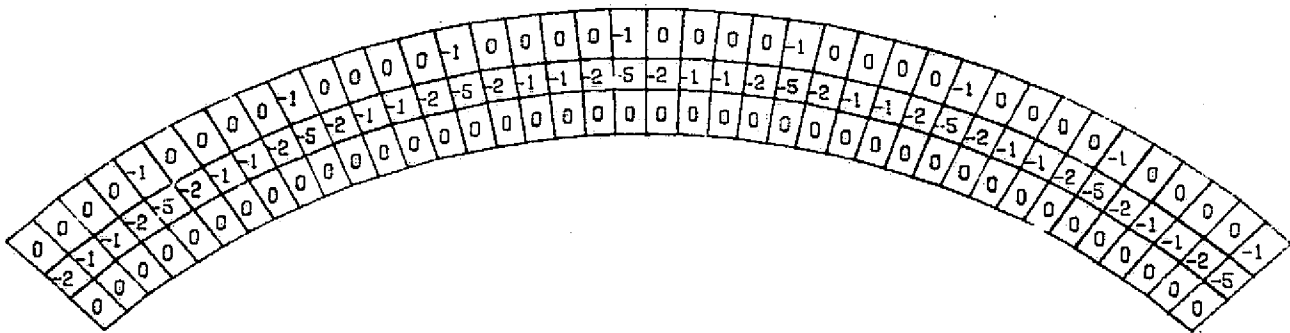

ORIGINAL PAGE IS
OF POOR QUALITY

SPEC
2.1

NTF BULKHEAD
FLANGE SURFACE

0 ——— 21
SCALE

FIG 51

1/1/1

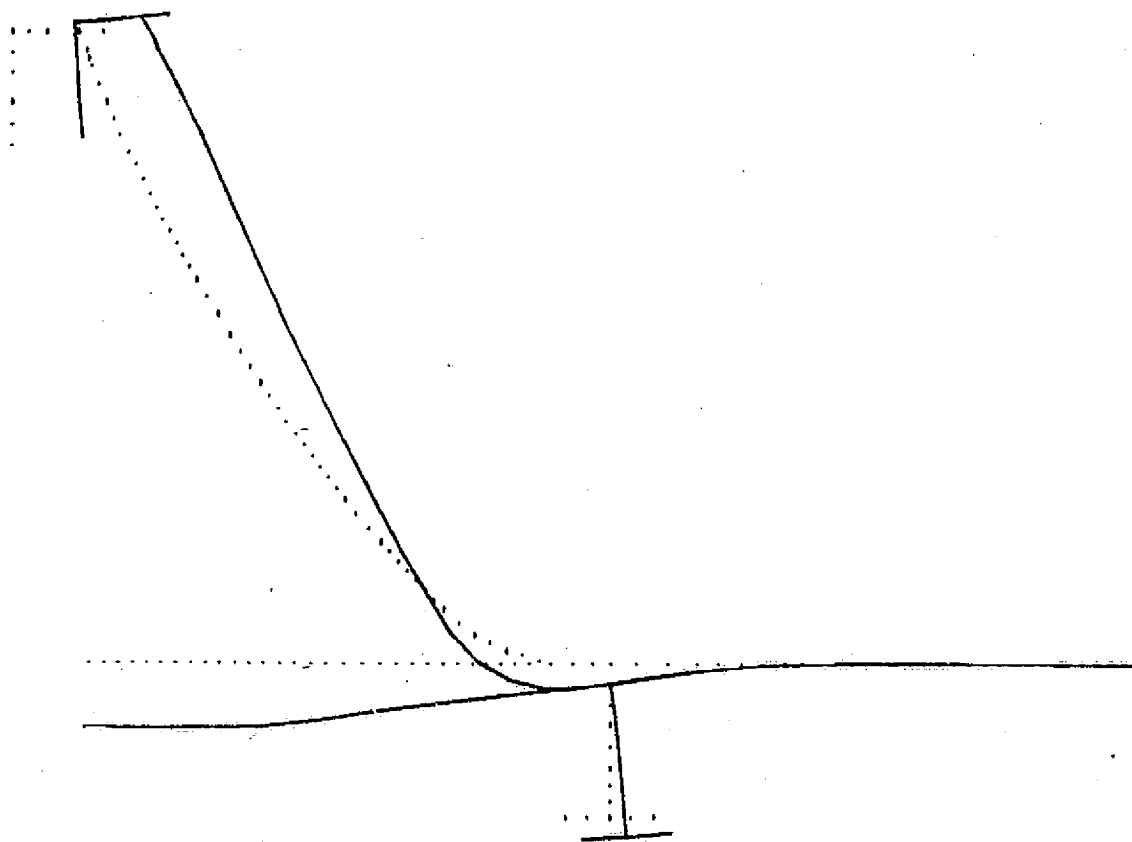

SPEC
12.1

NTF BULKHEAD
CROSS-SECTION VIEW

0 SCALE 27

ORIGINAL PAGE IS
OF POOR QUALITY

FIG 58

1/1/1

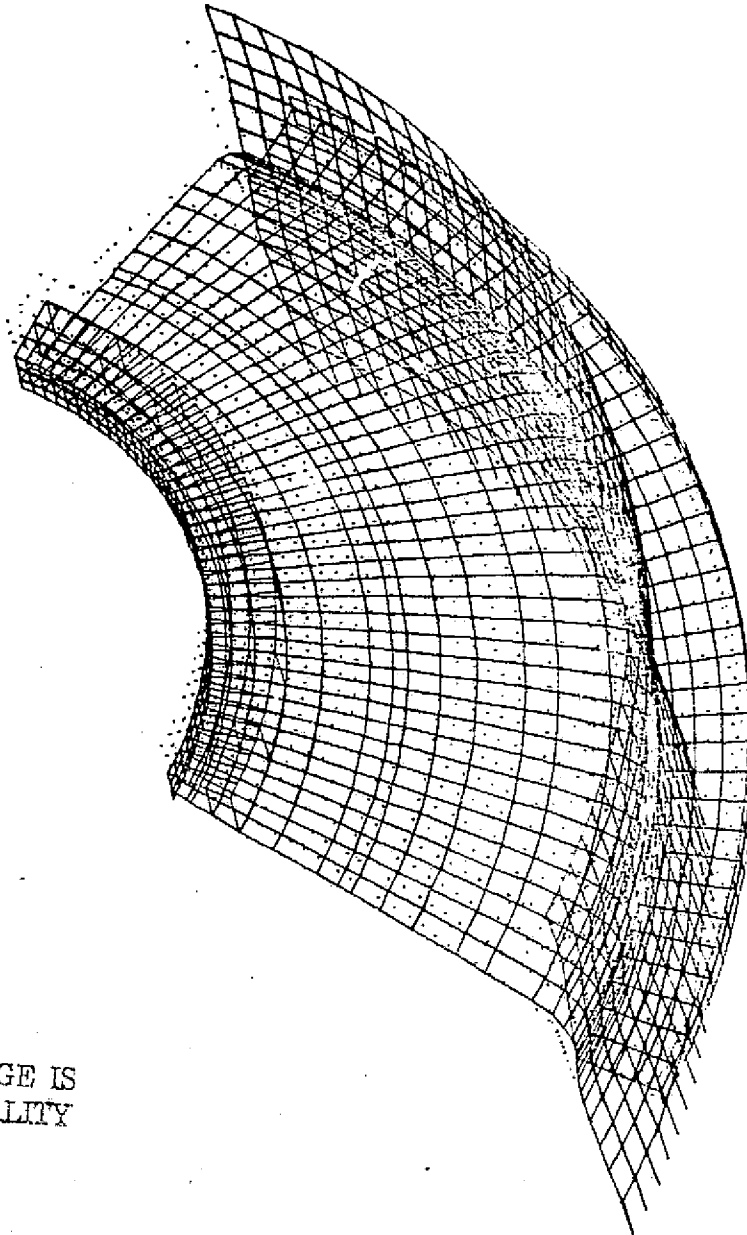

ORIGINAL PAGE IS
OF POOR QUALITY

SPEC
1.1

NTF BULKHEAD
..VALVE OPEN AND TEMP DIST

0 SCALE 44

FIG 59

CASE 2

GATE VALVE OPEN
STRESS PLOTS

FIGURES GO THRU 86

COMPUTER RUN NO. LEH

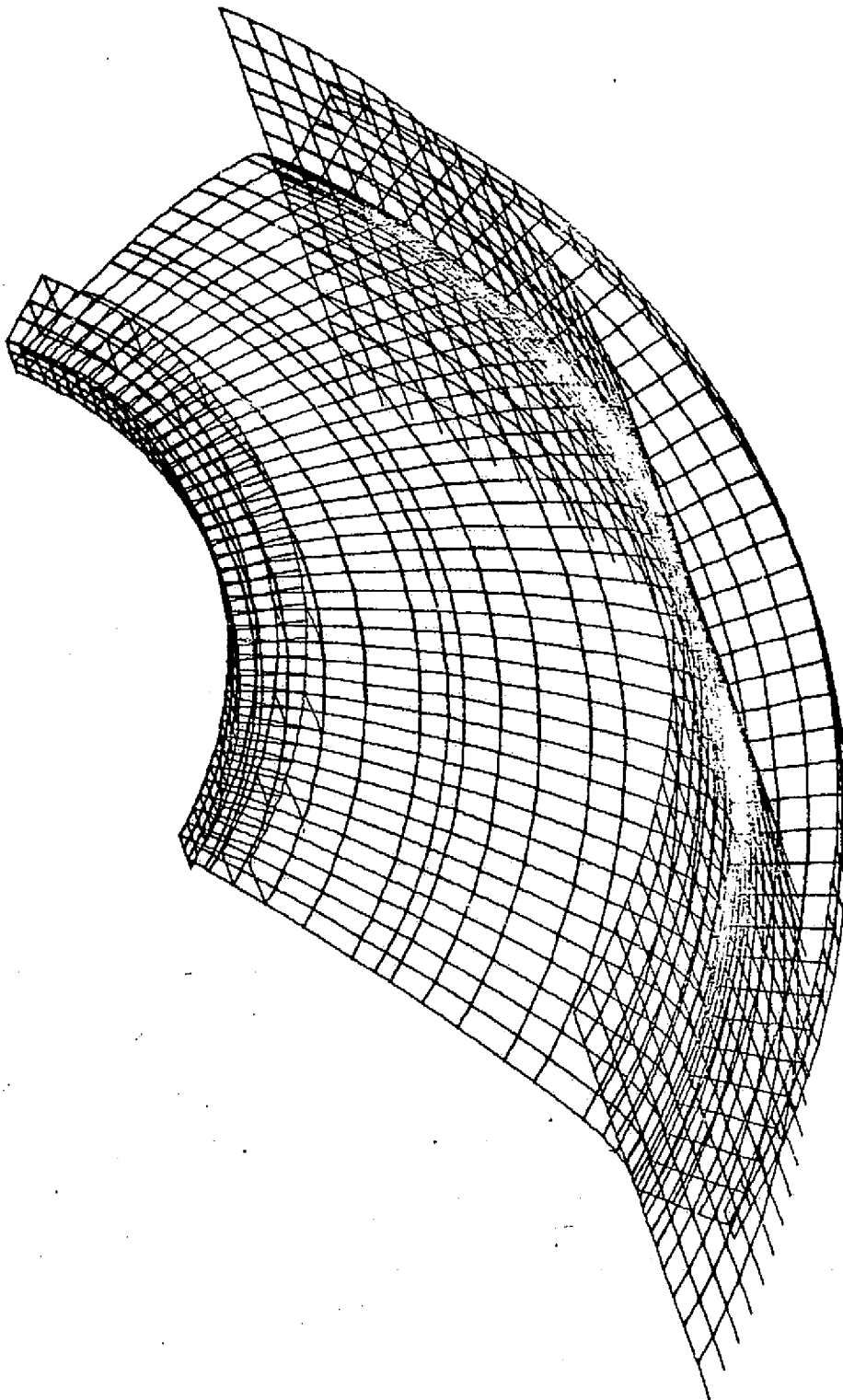

NTE...BULKHEAD...

0 SCALE 41

FIG. 60

DISPLAY= SX /1000 , NODE= 1 , SURFACE= 1

1/1/1

5	5	5	4	4	4	4	4	4	4	4	4	7	11	14	16	16
5	5	5	4	4	4	4	4	4	4	4	4	7	11	14	16	16
5	5	5	4	4	4	4	4	4	4	4	4	7	11	14	16	16
5	5	5	4	4	4	4	4	4	4	4	4	7	11	14	16	16
5	5	5	4	4	4	4	4	4	4	4	4	7	11	14	16	16
5	5	5	4	4	4	4	4	4	4	4	4	7	11	14	16	16
5	5	5	4	4	4	4	4	4	4	4	4	7	11	14	16	16
5	5	5	4	4	4	4	4	4	4	4	4	7	11	14	16	16
5	5	5	4	4	4	4	4	4	4	4	4	7	11	14	16	16
5	5	5	4	4	4	4	4	4	4	4	4	7	11	14	16	16
5	5	5	4	4	4	4	4	4	4	4	4	7	11	14	16	16
5	5	5	4	4	4	4	4	4	4	4	4	7	11	14	16	16
5	5	5	4	4	4	4	4	4	4	4	4	7	11	14	16	16
5	5	5	4	4	4	4	4	4	4	4	4	7	11	14	16	16
5	5	5	4	4	4	4	4	4	4	4	4	7	11	14	16	16
5	5	5	4	4	4	4	4	4	4	4	4	7	11	14	16	16
5	5	5	4	4	4	4	4	4	4	4	4	7	11	14	16	16
5	5	5	4	4	4	4	4	4	4	4	4	7	11	14	16	16
5	5	5	4	4	4	4	4	4	4	4	4	7	11	14	16	16
5	5	5	4	4	4	4	4	4	4	4	4	7	11	14	16	16
5	5	5	4	4	4	4	4	4	4	4	4	7	11	14	16	16
5	5	5	4	4	4	4	4	4	4	4	4	7	11	14	16	16
5	5	5	4	4	4	4	4	4	4	4	4	7	11	14	16	16
5	5	5	4	4	4	4	4	4	4	4	4	7	11	14	16	16
5	5	5	4	4	4	4	4	4	4	4	4	7	11	14	16	16
5	5	5	4	4	4	4	4	4	4	4	4	7	11	14	16	16
5	5	5	4	4	4	4	4	4	4	4	4	7	11	14	16	16
5	5	5	4	4	4	4	4	4	4	4	4	7	11	14	16	16

SPEC 5.1

NTF BULKHEAD SHELL

SCALE 36

FIG 62

DISPLAY= SX /1000 , NODE= 1 , SURFACE= 2

5	5	5	4	4	4	4	4	4	4	4	6	7	9	12	13	15	16
5	5	5	4	4	4	4	4	4	4	4	6	7	9	12	13	15	16
5	5	5	4	4	4	4	4	4	4	4	6	7	9	12	13	15	16
5	5	5	4	4	4	4	4	4	4	4	6	7	9	12	13	15	16
5	5	5	4	4	4	4	4	4	4	4	6	7	9	12	13	15	16
5	5	5	4	4	4	4	4	4	4	4	6	7	9	12	13	15	16
5	5	5	4	4	4	4	4	4	4	4	6	7	9	12	13	15	16
5	5	5	4	4	4	4	4	4	4	4	6	7	9	12	13	15	16
5	5	5	4	4	4	4	4	4	4	4	6	7	9	12	13	15	16
5	5	5	4	4	4	4	4	4	4	4	6	7	9	12	13	15	16
5	5	5	4	4	4	4	4	4	4	4	6	7	9	12	13	15	16
5	5	5	4	4	4	4	4	4	4	4	6	7	9	12	13	15	16
5	5	5	4	4	4	4	4	4	4	4	6	7	9	12	13	15	16
5	5	5	4	4	4	4	4	4	4	4	6	7	9	12	13	15	16
5	5	5	4	4	4	4	4	4	4	4	6	7	9	12	13	15	16
5	5	5	4	4	4	4	4	4	4	4	6	7	9	12	13	15	16
5	5	5	4	4	4	4	4	4	4	4	6	7	9	12	13	15	16
5	5	5	4	4	4	4	4	4	4	4	6	7	9	12	13	15	16
5	5	5	4	4	4	4	4	4	4	4	6	7	9	12	13	15	16
5	5	5	4	4	4	4	4	4	4	4	6	7	9	12	13	15	16
5	5	5	4	4	4	4	4	4	4	4	6	7	9	12	13	15	16
5	5	5	4	4	4	4	4	4	4	4	6	7	9	12	13	15	16
5	5	5	4	4	4	4	4	4	4	4	6	7	9	12	13	15	16
5	5	5	4	4	4	4	4	4	4	4	6	7	9	12	13	15	16
5	5	5	4	4	4	4	4	4	4	4	6	7	9	12	13	15	16
5	5	5	4	4	4	4	4	4	4	4	6	7	9	12	13	15	16
5	5	5	4	4	4	4	4	4	4	4	6	7	9	12	13	15	16
5	5	5	4	4	4	4	4	4	4	4	6	7	9	12	13	15	16
5	5	5	4	4	4	4	4	4	4	4	6	7	9	12	13	15	16
5	5	5	4	4	4	4	4	4	4	4	6	7	9	12	13	15	16
5	5	5	4	4	4	4	4	4	4	4	6	7	9	12	13	15	16
5	5	5	4	4	4	4	4	4	4	4	6	7	9	12	13	15	16
5	5	5	4	4	4	4	4	4	4	4	6	7	9	12	13	15	16
5	5	5	4	4	4	4	4	4	4	4	6	7	9	12	13	15	16
5	5	5	4	4	4	4	4	4	4	4	6	7	9	12	13	15	16
5	5	5	4	4	4	4	4	4	4	4	6	7	9	12	13	15	16
5	5	5	4	4	4	4	4	4	4	4	6	7	9	12	13	15	16
5	5	5	4	4	4	4	4	4	4	4	6	7	9	12	13	15	16
5	5	5	4	4	4	4	4	4	4	4	6	7	9	12	13	15	16
5	5	5	4	4	4	4	4	4	4	4	6	7	9	12	13	15	16

SPEC 5.1

NIF BULKHEAD SHELL

Q SCALE 36

DISPLAY= SY /1000 , NODE= 1 , SURFACE= 0

1/1/1

2	2	2	2	2	2	2	1	1	1	1	3	3	5	8	8	8	8
2	2	2	2	2	2	2	1	1	1	1	3	3	5	8	8	8	8
2	2	2	2	2	2	2	1	1	1	1	3	3	5	8	8	8	8
2	2	2	2	2	2	2	1	1	1	1	3	3	5	8	8	8	8
2	2	2	2	2	2	2	1	1	1	1	3	3	5	8	8	8	8
2	2	2	2	2	2	2	1	1	1	1	3	3	5	8	8	8	8
2	2	2	2	2	2	2	1	1	1	1	3	3	5	8	8	8	8
2	2	2	2	2	2	2	1	1	1	1	3	3	5	8	8	8	8
2	2	2	2	2	2	2	1	1	1	1	3	3	5	8	8	8	8
2	2	2	2	2	2	2	1	1	1	1	3	3	5	8	8	8	8
2	2	2	2	2	2	2	1	1	1	1	3	3	5	8	8	8	8
2	2	2	2	2	2	2	1	1	1	1	3	3	5	8	8	8	8
2	2	2	2	2	2	2	1	1	1	1	3	3	5	8	8	8	8
2	2	2	2	2	2	2	1	1	1	1	3	3	5	8	8	8	8
2	2	2	2	2	2	2	1	1	1	1	3	3	5	8	8	8	8
2	2	2	2	2	2	2	1	1	1	1	3	3	5	8	8	8	8
2	2	2	2	2	2	2	1	1	1	1	3	3	5	8	8	8	8
2	2	2	2	2	2	2	1	1	1	1	3	3	5	8	8	8	8
2	2	2	2	2	2	2	1	1	1	1	3	3	5	8	8	8	8
2	2	2	2	2	2	2	1	1	1	1	3	3	5	8	8	8	8
2	2	2	2	2	2	2	1	1	1	1	3	3	5	8	8	8	8
2	2	2	2	2	2	2	1	1	1	1	3	3	5	8	8	8	8
2	2	2	2	2	2	2	1	1	1	1	3	3	5	8	8	8	8
2	2	2	2	2	2	2	1	1	1	1	3	3	5	8	8	8	8
2	2	2	2	2	2	2	1	1	1	1	3	3	5	8	8	8	8
2	2	2	2	2	2	2	1	1	1	1	3	3	5	8	8	8	8
2	2	2	2	2	2	2	1	1	1	1	3	3	5	8	8	8	8
2	2	2	2	2	2	2	1	1	1	1	3	3	5	8	8	8	8
2	2	2	2	2	2	2	1	1	1	1	3	3	5	8	8	8	8
2	2	2	2	2	2	2	1	1	1	1	3	3	5	8	8	8	8
2	2	2	2	2	2	2	1	1	1	1	3	3	5	8	8	8	8
2	2	2	2	2	2	2	1	1	1	1	3	3	5	8	8	8	8
2	2	2	2	2	2	2	1	1	1	1	3	3	5	8	8	8	8
2	2	2	2	2	2	2	1	1	1	1	3	3	5	8	8	8	8
2	2	2	2	2	2	2	1	1	1	1	3	3	5	8	8	8	8

SPEC
S.1

NIF BULKHEAD
SHELL

0 SCALE 36

FIG 64

1/1/1

DISPLAY= SY /1000 , NODE= 1 , SURFACE= 1

2	2	2	2	2	3	3	2	3	HL-1	0	2	7	10	10	8
2	2	2	2	2	3	3	2	3	HL-1	0	2	7	10	10	8
2	2	2	2	2	3	3	2	3	HL-1	0	2	7	10	10	8
2	2	2	2	2	3	3	2	3	HL-1	0	2	7	10	10	8
2	2	2	2	2	3	3	2	3	HL-1	0	2	7	10	10	8
2	2	2	2	2	3	3	2	3	HL-1	0	2	7	10	10	8
2	2	2	2	2	3	3	2	3	HL-1	0	2	7	10	10	8
2	2	2	2	2	3	3	2	3	HL-1	0	2	7	10	10	8
2	2	2	2	2	3	3	2	3	HL-1	0	2	7	10	10	8
2	2	2	2	2	3	3	2	3	HL-1	0	2	7	10	10	8
2	2	2	2	2	3	3	2	3	HL-1	0	2	7	10	10	8
2	2	2	2	2	3	3	2	3	HL-1	0	2	7	10	10	8
2	2	2	2	2	3	3	2	3	HL-1	0	2	7	10	10	8
2	2	2	2	2	3	3	2	3	HL-1	0	2	7	10	10	8
2	2	2	2	2	3	3	2	3	HL-1	0	2	7	10	10	8
2	2	2	2	2	3	3	2	3	HL-1	0	2	7	10	10	8
2	2	2	2	2	3	3	2	3	HL-1	0	2	7	10	10	8
2	2	2	2	2	3	3	2	3	HL-1	0	2	7	10	10	8
2	2	2	2	2	3	3	2	3	HL-1	0	2	7	10	10	8
2	2	2	2	2	3	3	2	3	HL-1	0	2	7	10	10	8
2	2	2	2	2	3	3	2	3	HL-1	0	2	7	10	10	8
2	2	2	2	2	3	3	2	3	HL-1	0	2	7	10	10	8
2	2	2	2	2	3	3	2	3	HL-1	0	2	7	10	10	8
2	2	2	2	2	3	3	2	3	HL-1	0	2	7	10	10	8
2	2	2	2	2	3	3	2	3	HL-1	0	2	7	10	10	8
2	2	2	2	2	3	3	2	3	HL-1	0	2	7	10	10	8
2	2	2	2	2	3	3	2	3	HL-1	0	2	7	10	10	8
2	2	2	2	2	3	3	2	3	HL-1	0	2	7	10	10	8
2	2	2	2	2	3	3	2	3	HL-1	0	2	7	10	10	8
2	2	2	2	2	3	3	2	3	HL-1	0	2	7	10	10	8
2	2	2	2	2	3	3	2	3	HL-1	0	2	7	10	10	8
2	2	2	2	2	3	3	2	3	HL-1	0	2	7	10	10	8
2	2	2	2	2	3	3	2	3	HL-1	0	2	7	10	10	8
2	2	2	2	2	3	3	2	3	HL-1	0	2	7	10	10	8

SPEC 5.1

NTF BULKHEAD SHELL

SCALE 36

ORIGINAL PAGE IS OF POOR QUALITY

FIG 65

1/1/1

DISPLAY= SY /1000 . NODE= 1 . SURFACE= 2

2	2	2	2	2	1	0	0	0	2	4	8	7	8	9	6	6	7
2	2	2	2	2	1	0	0	0	2	4	8	7	8	9	6	6	7
2	2	2	2	2	1	0	0	0	2	4	8	7	8	9	6	6	7
2	2	2	2	2	1	0	0	0	2	4	8	7	8	9	6	6	7
2	2	2	2	2	1	0	0	0	2	4	8	7	8	9	6	6	7
2	2	2	2	2	1	0	0	0	2	4	8	7	8	9	6	6	7
2	2	2	2	2	1	0	0	0	2	4	8	7	8	9	6	6	7
2	2	2	2	2	1	0	0	0	2	4	8	7	8	9	6	6	7
2	2	2	2	2	1	0	0	0	2	4	8	7	8	9	6	6	7
2	2	2	2	2	1	0	0	0	2	4	8	7	8	9	6	6	7
2	2	2	2	2	1	0	0	0	2	4	8	7	8	9	6	6	7
2	2	2	2	2	1	0	0	0	2	4	8	7	8	9	6	6	7
2	2	2	2	2	1	0	0	0	2	4	8	7	8	9	6	6	7
2	2	2	2	2	1	0	0	0	2	4	8	7	8	9	6	6	7
2	2	2	2	2	1	0	0	0	2	4	8	7	8	9	6	6	7
2	2	2	2	2	1	0	0	0	2	4	8	7	8	9	6	6	7
2	2	2	2	2	1	0	0	0	2	4	8	7	8	9	6	6	7
2	2	2	2	2	1	0	0	0	2	4	8	7	8	9	6	6	7
2	2	2	2	2	1	0	0	0	2	4	8	7	8	9	6	6	7
2	2	2	2	2	1	0	0	0	2	4	8	7	8	9	6	6	7
2	2	2	2	2	1	0	0	0	2	4	8	7	8	9	6	6	7
2	2	2	2	2	1	0	0	0	2	4	8	7	8	9	6	6	7
2	2	2	2	2	1	0	0	0	2	4	8	7	8	9	6	6	7
2	2	2	2	2	1	0	0	0	2	4	8	7	8	9	6	6	7
2	2	2	2	2	1	0	0	0	2	4	8	7	8	9	6	6	7
2	2	2	2	2	1	0	0	0	2	4	8	7	8	9	6	6	7
2	2	2	2	2	1	0	0	0	2	4	8	7	8	9	6	6	7
2	2	2	2	2	1	0	0	0	2	4	8	7	8	9	6	6	7
2	2	2	2	2	1	0	0	0	2	4	8	7	8	9	6	6	7
2	2	2	2	2	1	0	0	0	2	4	8	7	8	9	6	6	7
2	2	2	2	2	1	0	0	0	2	4	8	7	8	9	6	6	7
2	2	2	2	2	1	0	0	0	2	4	8	7	8	9	6	6	7
2	2	2	2	2	1	0	0	0	2	4	8	7	8	9	6	6	7

SPEC 5.1 NTF BULKHEAD SHELL

0 SCALE 35

FIG 66

DISPLAY= SX /1000 , NODE= 1 , SURFACE= 0

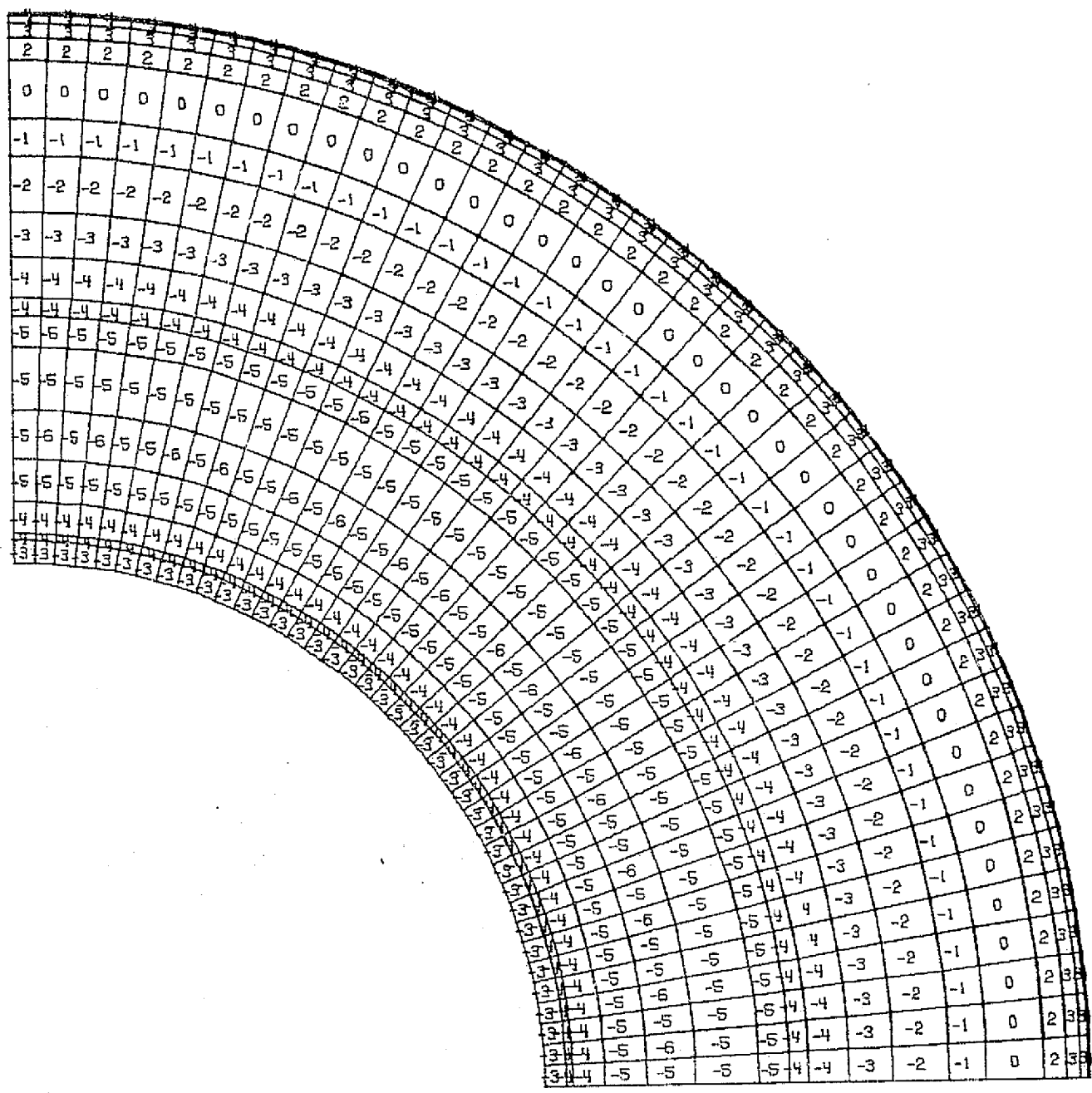

SPEC 3.1

NTF BULKHEAD DOME

0 SCALE 26

ORIGINAL PAGE IS OF POOR QUALITY

1/1/1

DISPLAY= SX /1000 , NODE= 1 , SURFACE= 1

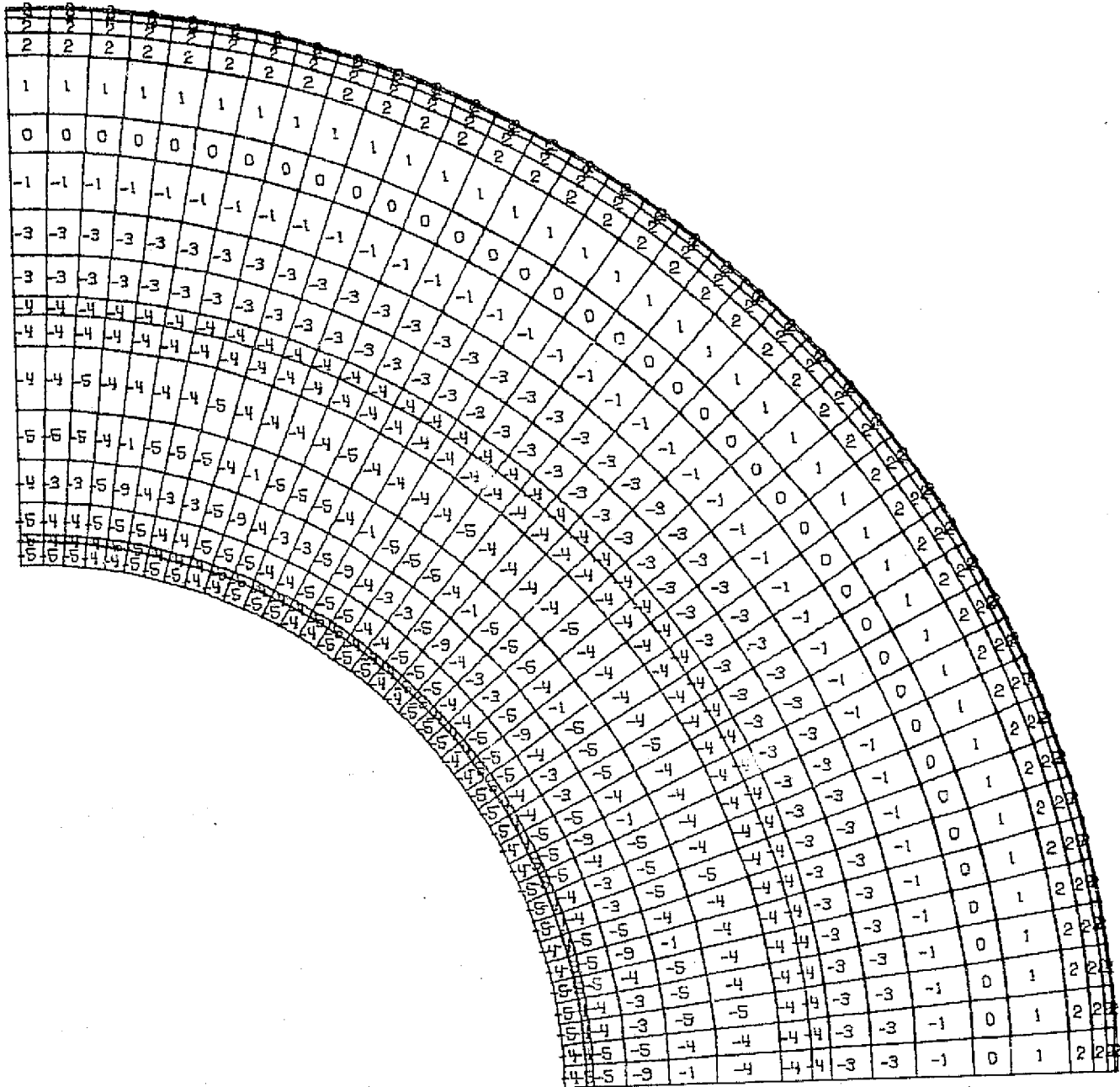

SPEC
3.1

NTF BULKHEAD
DOME

Q SCALE 26

FIG 68

1/1/1

DISPLAY= SX /1000 , NODE= 1 , SURFACE= 2

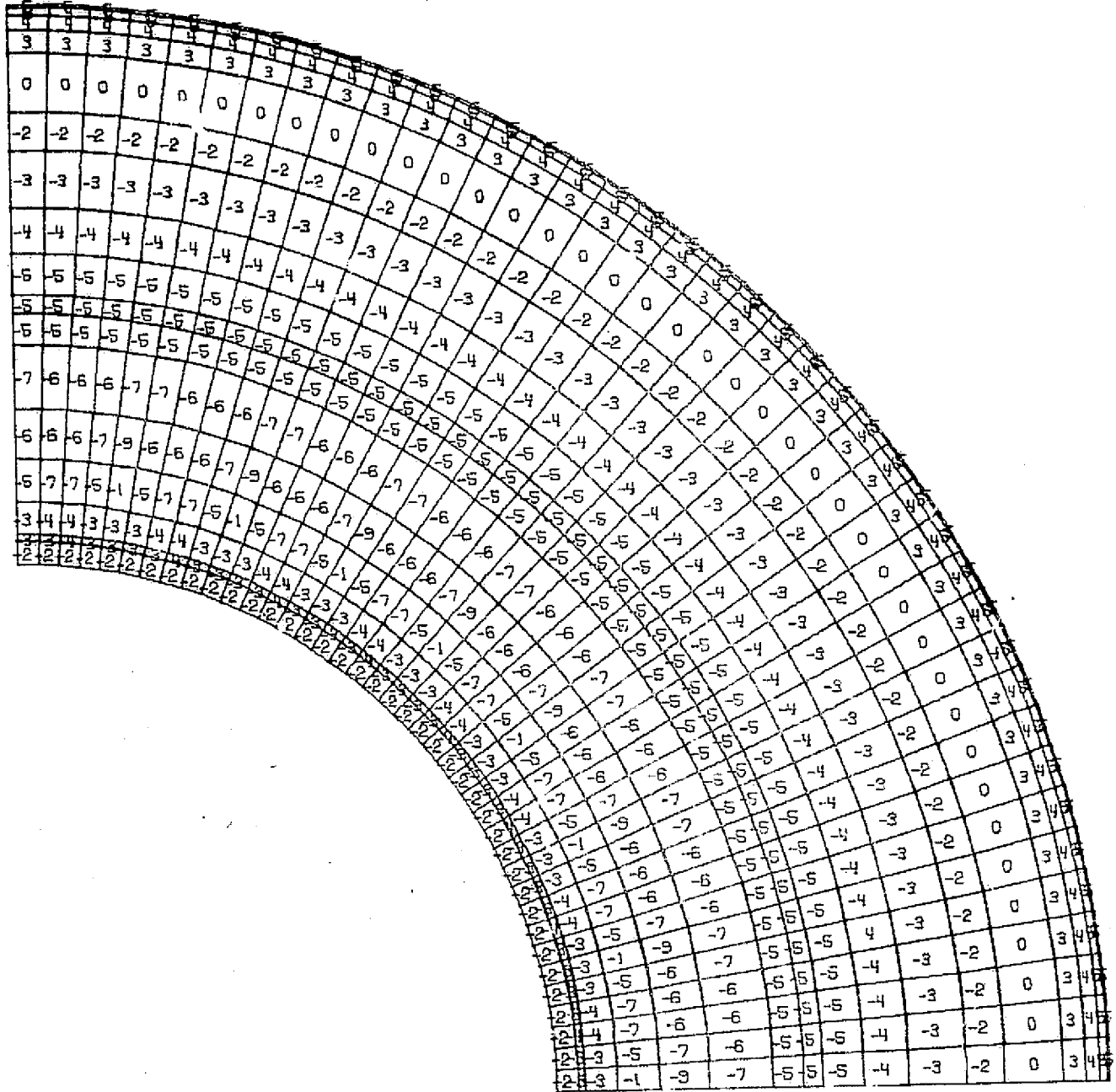

SPEC
3.1

NTF BULKHEAD
DOME

0 SCALE 26

ORIGINAL PAGE IS
OF POOR QUALITY

FIG 69

DISPLAY= SY /1000 . NODE= 1 . SURFACE= 0

1/1/1

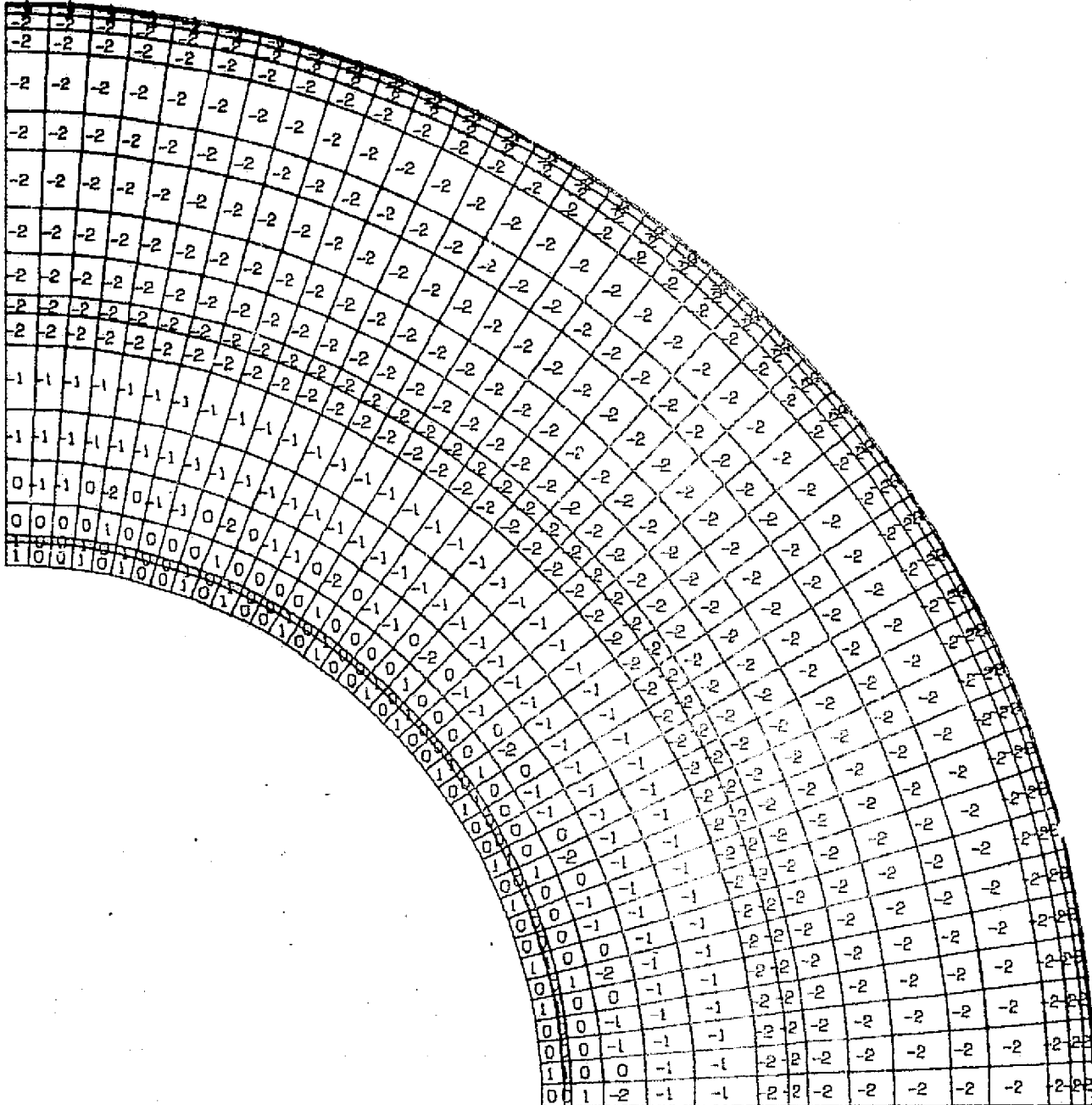

SPEC
3.1

NTF BULKHEAD
DOME

0 SCALE 26

FIG. 70

DISPLAY= SY /1000 , NODE= 1. SURFACE= 1

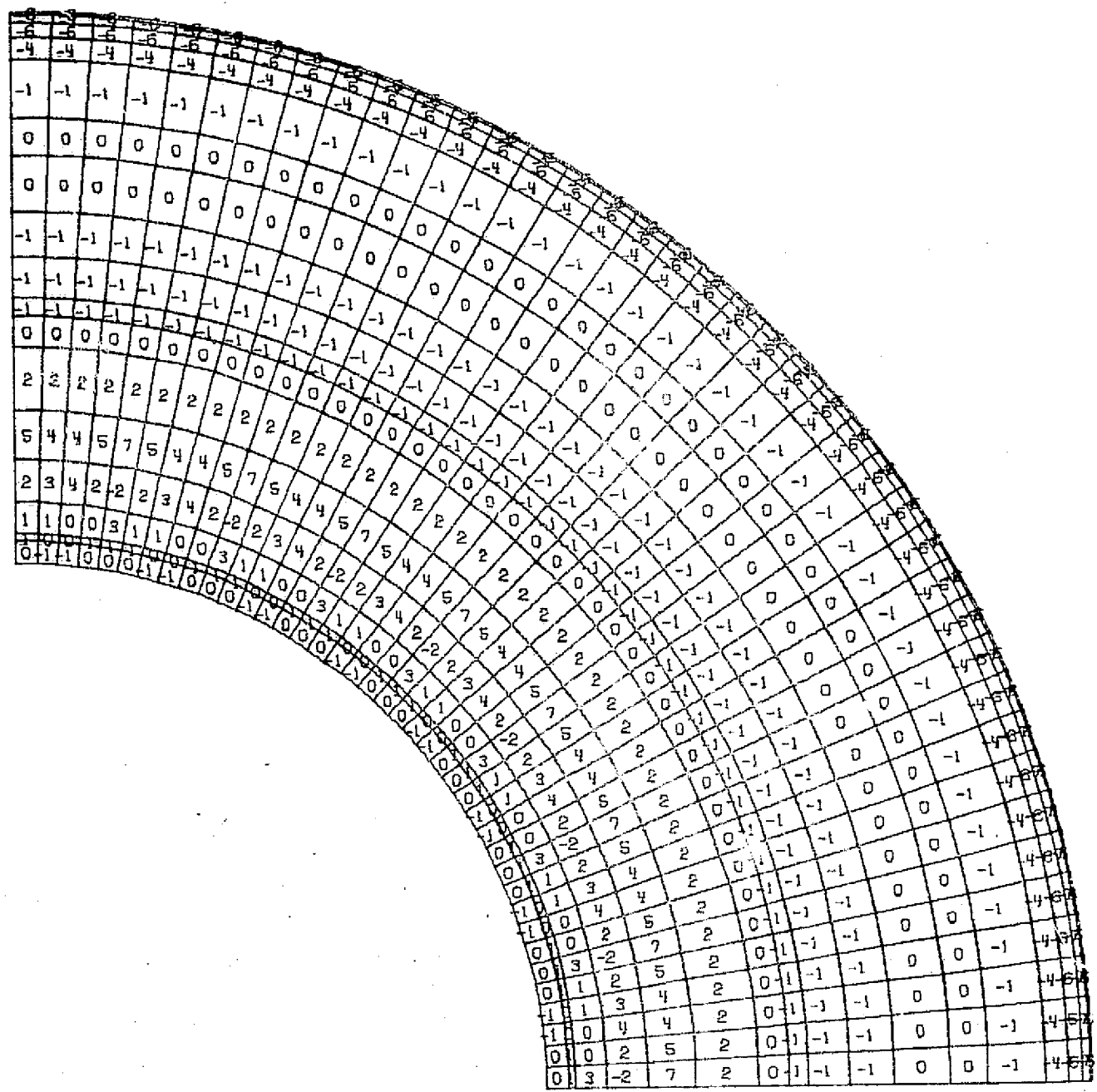

SPEC 3.1

NTF BULKHEAD DOME

0 SCALE 25

CONTINUED PAGE IS
IN FRONT OF THIS

FIG 71

1/1/1

DISPLAY= SY /1000 , NODE= 1 , SURFACE= 2

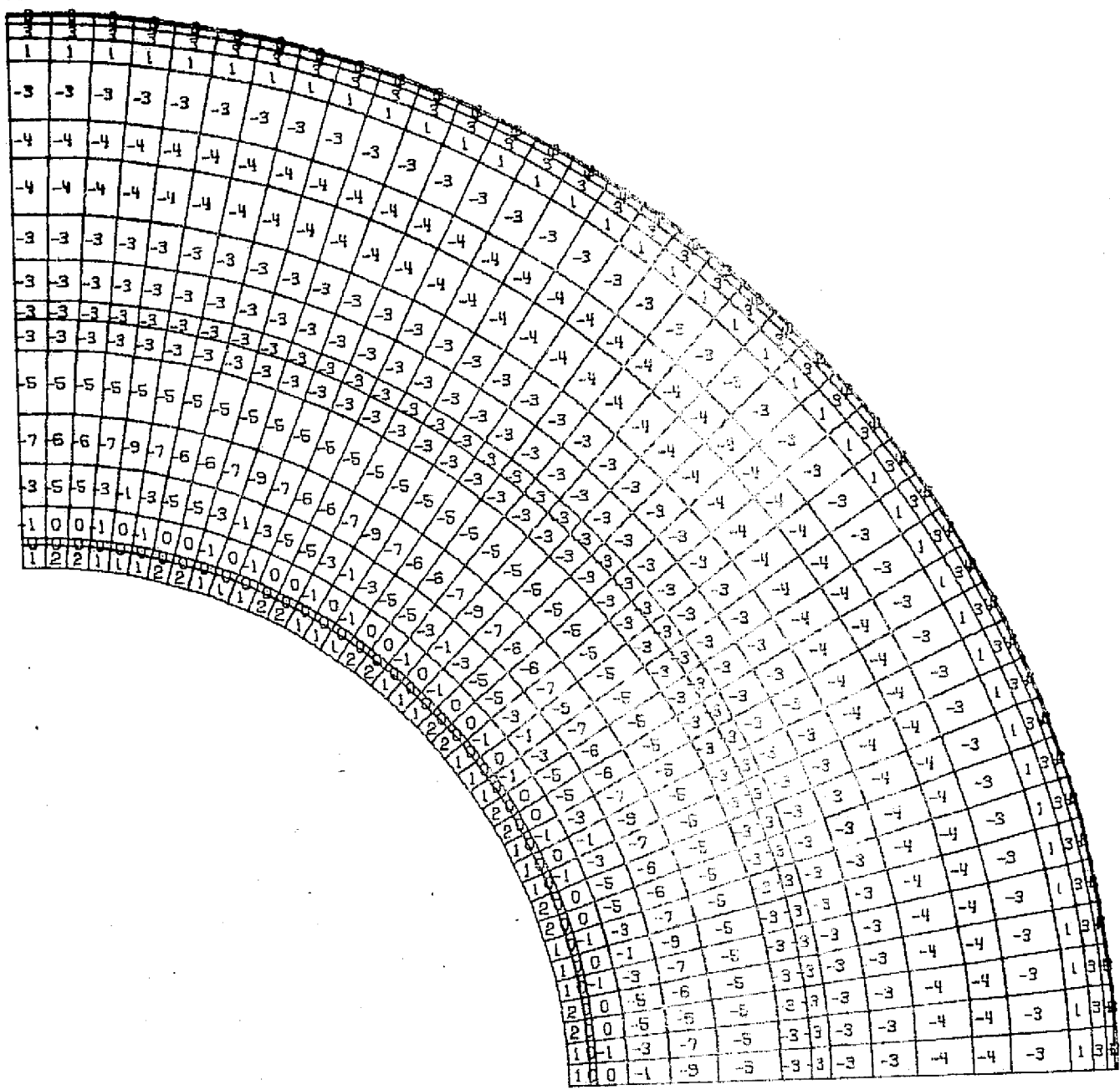

SPEC
3.1

NTF_BULKHEAD
DOME

0 SCALE 26

FIG. 72

DISPLAY= SX /1000 , NODE= 1 , SURFACE= 1

17171

3	3	3	3	3	3	3	3	3	3	3	3	3	3	3	3	3	3	3	3	3	3	3	3	3	3	3	3	3	3	3	3	3	3	3	3	3	3	3	3	3
-1	-1	-1	-1	-1	-1	-1	-1	-1	-1	-1	-1	-1	-1	-1	-1	-1	-1	-1	-1	-1	-1	-1	-1	-1	-1	-1	-1	-1	-1	-1	-1	-1	-1	-1	-1	-1	-1	-1	-1	-1
-4	-4	-3	-3	-4	-4	-3	-3	-4	-4	-3	-3	-4	-4	-3	-3	-4	-4	-3	-3	-4	-4	-3	-3	-4	-4	-3	-3	-4	-4	-3	-3	-4	-4	-3	-3	-4	-4	-3	-3	-4

SPEC 10.1

NTF BULKHEAD HATCH OPENING

0 SCALE 18

FIG. 74

DISPLAY= SX /1000 . NODE= 1 . SURFACE= 0

1/1/1

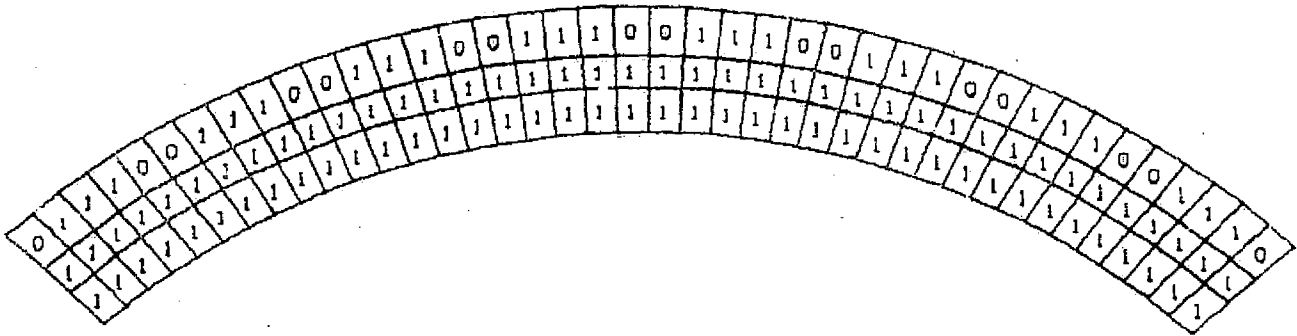

SPEC
2.1

NTF BULKHEAD
FLANGE SURFACE

ORIGINAL PAGE IS
OF POOR QUALITY

0 ——— 21
SCALE

FIG 79

DISPLAY= SX /1000 , NODE= 1, SURFACE= 1

1/1/1

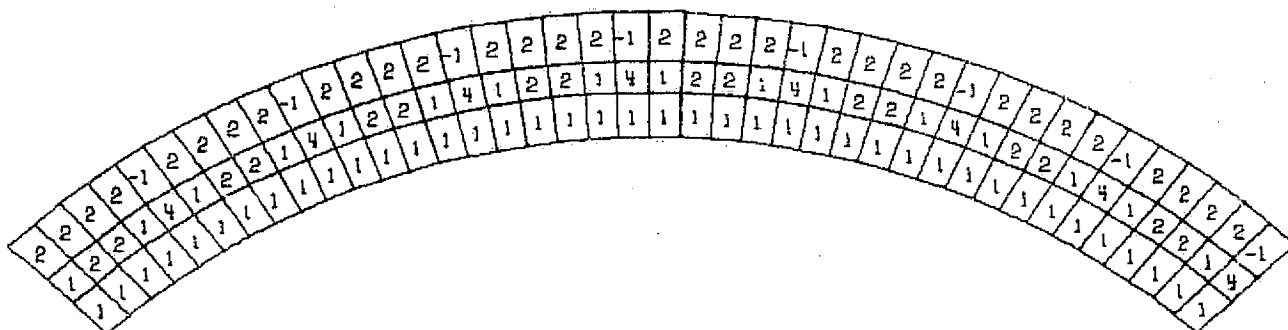

SPEC
2-1

NTF BULKHEAD
FLANGE SURFACE

0 ————— 21
SCALE

DISPLAY= SX /1000 , NODE= 1 , SURFACE= 2

1/1/1

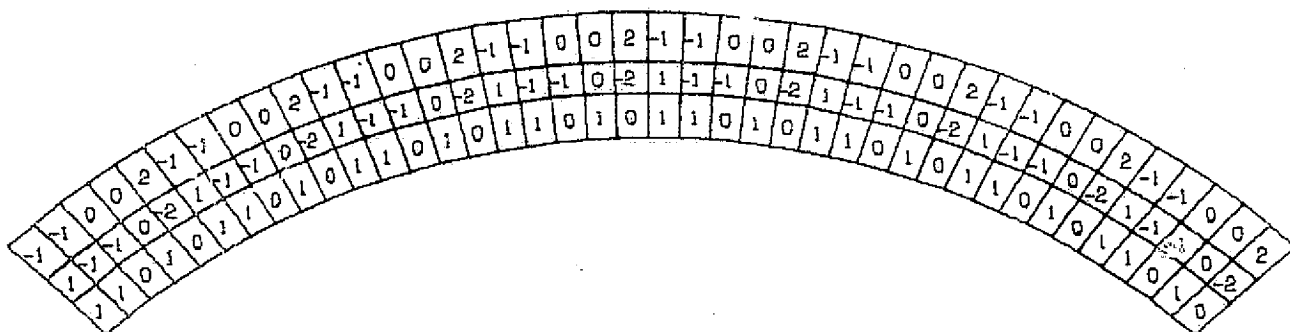

SPEC
2.1

NTF BULKHEAD
FLANGE SURFACE

0  21
SCALE

FIG 81

DISPLAY= SY /1000 . NODE= 1. SURFACE= 0

1/1/1

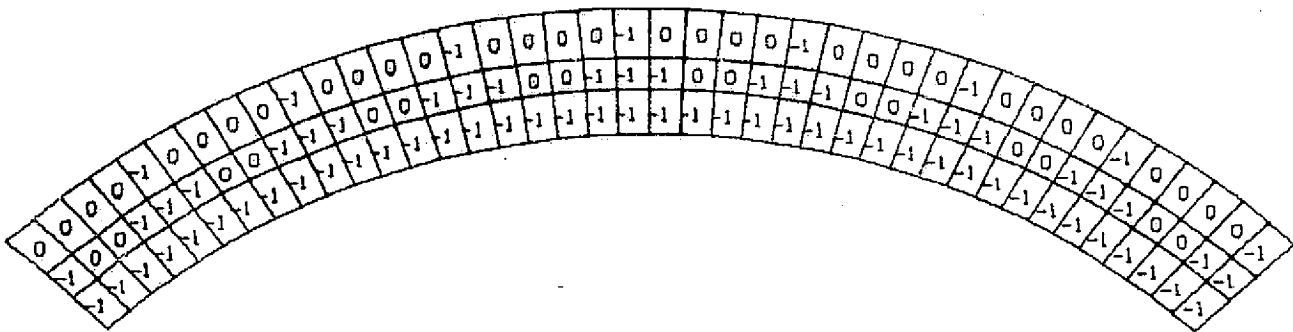

SPEC
2.1

NTF BULKHEAD
FLANGE SURFACE

0 ——— 21
SCALE

DISPLAY= SY /1000 . NODE= 1 . SURFACE= 1

1/1/1

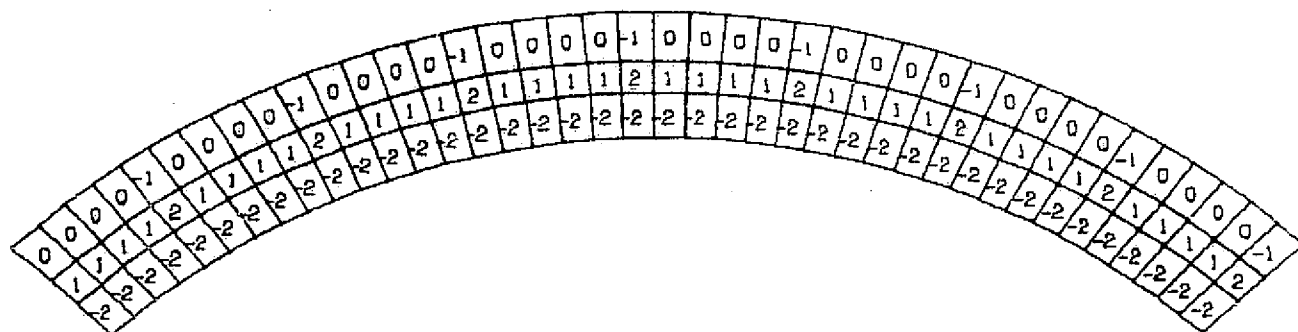

SPEC
2.1

NTF BULKHEAD
FLANGE SURFACE

ORIGINAL PAGE IS
OF POOR QUALITY

0 21
SCALE

FIG 83

DISPLAY= SY /1000 . NODE= 1 . SURFACE= 2

1/1/1

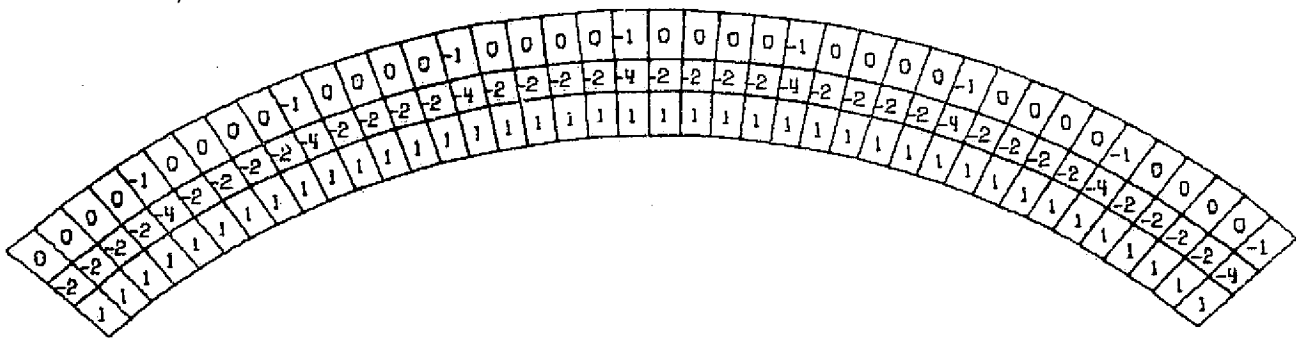

SPEC
2.1

NTF BULKHEAD
FLANGE SURFACE

0 ——— 21
SCALE

FIG. 84

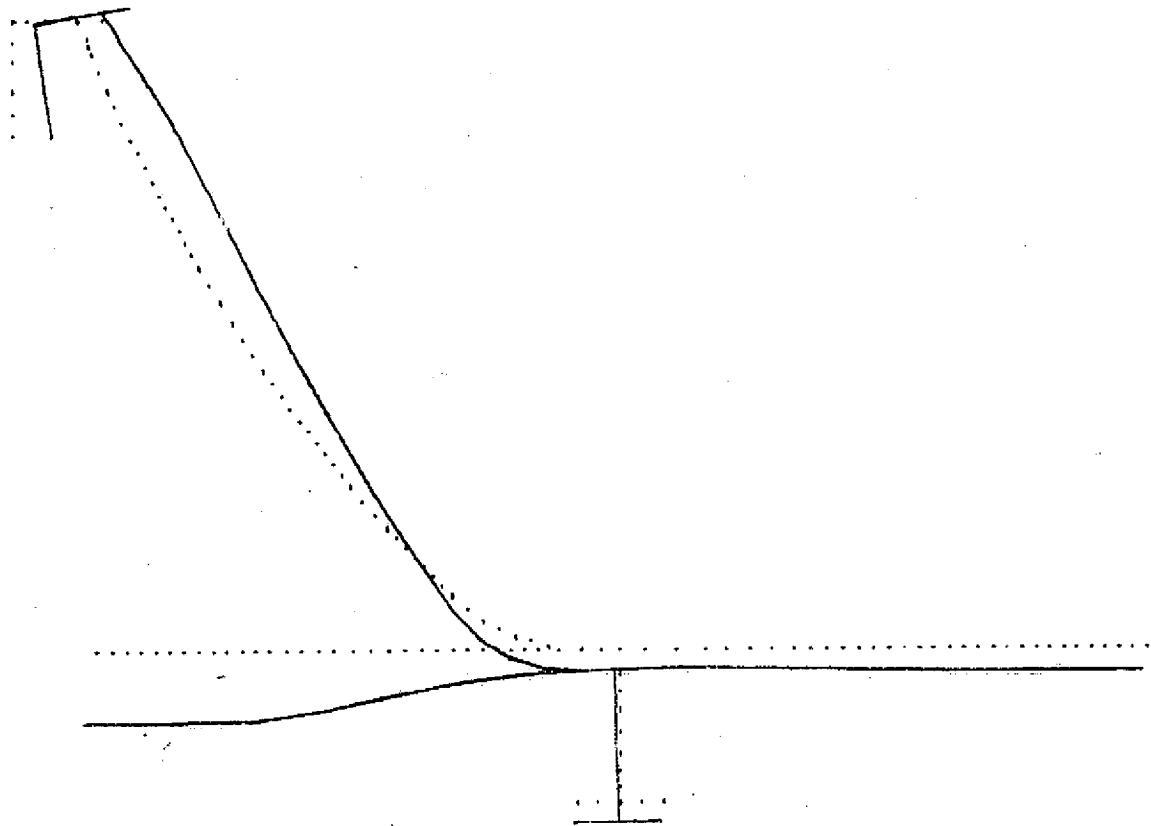

SPEC
12.1

NTF BULKHEAD
CROSS-SECTION VIEW

0 ——— 27
SCALE

ORIGINAL PAGE IS
OF POOR QUALITY

FIG 85

1/1/1

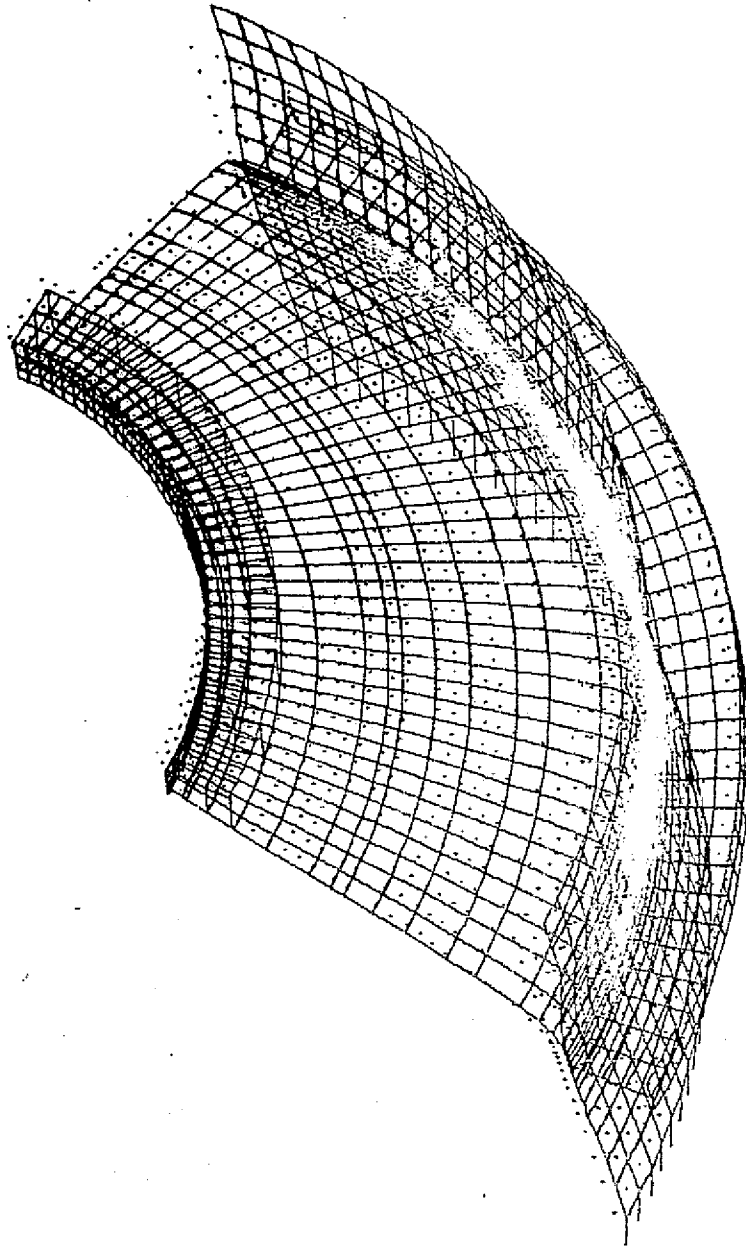

SPEC
1.1

NTE. . BULKHEAD

0 ——— 44
SCALE

FIG 86

CASE 3

FULL PRESSURE
STRESS PLOTS

FIGURES 87 THRU 113

COMPUTER RUN NO. AAU

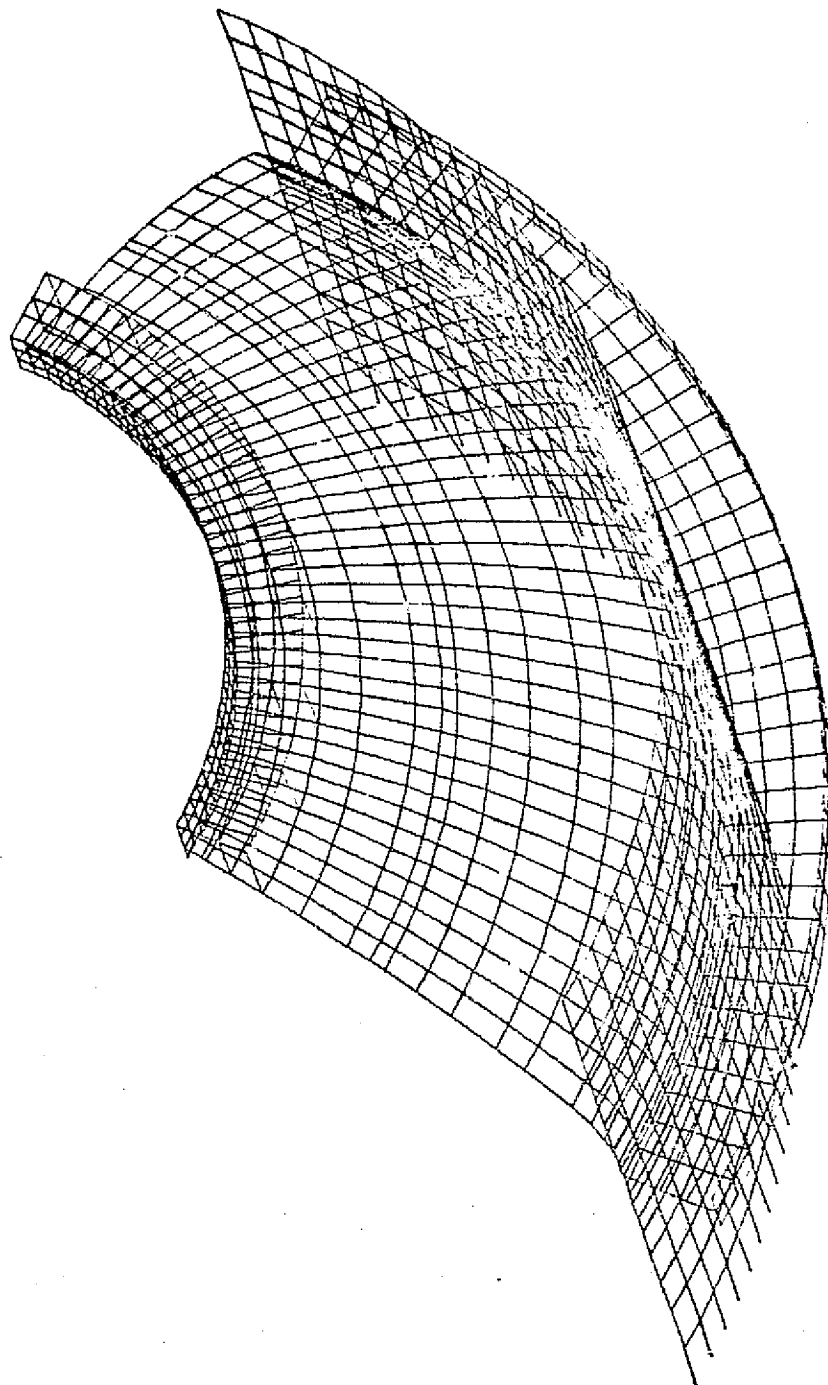

SPEC
1.1

NTF BULKHEAD

0 SCALE 41

FIG. 87

DISPLAY= SX /1000 , NODE= 1 , SURFACE= 0

1/1/1

10	10	10	9	8	7	6	5	4	4	4	4	6	11	13	15	16
10	10	10	9	8	7	6	5	4	4	4	4	6	11	13	15	16
10	10	10	9	8	7	6	5	4	4	4	4	6	11	13	15	16
10	10	10	9	8	7	6	5	4	4	4	4	6	11	13	15	16
10	10	10	9	8	7	6	5	4	4	4	4	6	11	13	15	16
10	10	10	9	8	7	6	5	4	4	4	4	6	11	13	15	16
10	10	10	9	8	7	6	5	4	4	4	4	6	11	13	15	16
10	10	10	9	8	7	6	5	4	4	4	4	6	11	13	15	16
10	10	10	9	8	7	6	5	4	4	4	4	6	11	13	15	16
10	10	10	9	8	7	6	5	4	4	4	4	6	11	13	15	16
10	10	10	9	8	7	6	5	4	4	4	4	6	11	13	15	16
10	10	10	9	8	7	6	5	4	4	4	4	6	11	13	15	16
10	10	10	9	8	7	6	5	4	4	4	4	6	11	13	15	16
10	10	10	9	8	7	6	5	4	4	4	4	6	11	13	15	16
10	10	10	9	8	7	6	5	4	4	4	4	6	11	13	15	16
10	10	10	9	8	7	6	5	4	4	4	4	6	11	13	15	16
10	10	10	9	8	7	6	5	4	4	4	4	6	11	13	15	16
10	10	10	9	8	7	6	5	4	4	4	4	6	11	13	15	16
10	10	10	9	8	7	6	5	4	4	4	4	6	11	13	15	16
10	10	10	9	8	7	6	5	4	4	4	4	6	11	13	15	16
10	10	10	9	8	7	6	5	4	4	4	4	6	11	13	15	16
10	10	10	9	8	7	6	5	4	4	4	4	6	11	13	15	16
10	10	10	9	8	7	6	5	4	4	4	4	6	11	13	15	16
10	10	10	9	8	7	6	5	4	4	4	4	6	11	13	15	16
10	10	10	9	8	7	6	5	4	4	4	4	6	11	13	15	16
10	10	10	9	8	7	6	5	4	4	4	4	6	11	13	15	16
10	10	10	9	8	7	6	5	4	4	4	4	6	11	13	15	16
10	10	10	9	8	7	6	5	4	4	4	4	6	11	13	15	16
10	10	10	9	8	7	6	5	4	4	4	4	6	11	13	15	16
10	10	10	9	8	7	6	5	4	4	4	4	6	11	13	15	16

SPEC 5-1

NTF BULKHEAD SHELL

0 36
SCALE

ORIGINAL PAGE IS
OF POOR QUALITY

FIG. 88

DISPLAY= SX /1000 , NODE= 1 , SURFACE= 2

1/1/1

10	10	10	10	9	7	5	4	3	3	7	6	8	11	12	15	16
10	10	10	10	9	7	5	4	3	3	7	6	8	11	12	15	16
10	10	10	10	9	7	5	4	3	3	7	6	8	11	12	15	16
10	10	10	10	9	7	5	4	3	3	7	6	8	11	12	15	16
10	10	10	10	9	7	5	4	3	3	7	6	8	11	12	15	16
10	10	10	10	9	7	5	4	3	3	7	6	8	11	12	15	16
10	10	10	10	9	7	5	4	3	3	7	6	8	11	12	15	16
10	10	10	10	9	7	5	4	3	3	7	6	8	11	12	15	16
10	10	10	10	9	7	5	4	3	3	7	6	8	11	12	15	16
10	10	10	10	9	7	5	4	3	3	7	6	8	11	12	15	16
10	10	10	10	9	7	5	4	3	3	7	6	8	11	12	15	16
10	10	10	10	9	7	5	4	3	3	7	6	8	11	12	15	16
10	10	10	10	9	7	5	4	3	3	7	6	8	11	12	15	16
10	10	10	10	9	7	5	4	3	3	7	6	8	11	12	15	16
10	10	10	10	9	7	5	4	3	3	7	6	8	11	12	15	16
10	10	10	10	9	7	5	4	3	3	7	6	8	11	12	15	16
10	10	10	10	9	7	5	4	3	3	7	6	8	11	12	15	16
10	10	10	10	9	7	5	4	3	3	7	6	8	11	12	15	16
10	10	10	10	9	7	5	4	3	3	7	6	8	11	12	15	16
10	10	10	10	9	7	5	4	3	3	7	6	8	11	12	15	16
10	10	10	10	9	7	5	4	3	3	7	6	8	11	12	15	16
10	10	10	10	9	7	5	4	3	3	7	6	8	11	12	15	16
10	10	10	10	9	7	5	4	3	3	7	6	8	11	12	15	16
10	10	10	10	9	7	5	4	3	3	7	6	8	11	12	15	16
10	10	10	10	9	7	5	4	3	3	7	6	8	11	12	15	16
10	10	10	10	9	7	5	4	3	3	7	6	8	11	12	15	16
10	10	10	10	9	7	5	4	3	3	7	6	8	11	12	15	16
10	10	10	10	9	7	5	4	3	3	7	6	8	11	12	15	16
10	10	10	10	9	7	5	4	3	3	7	6	8	11	12	15	16
10	10	10	10	9	7	5	4	3	3	7	6	8	11	12	15	16
10	10	10	10	9	7	5	4	3	3	7	6	8	11	12	15	16
10	10	10	10	9	7	5	4	3	3	7	6	8	11	12	15	16
10	10	10	10	9	7	5	4	3	3	7	6	8	11	12	15	16
10	10	10	10	9	7	5	4	3	3	7	6	8	11	12	15	16
10	10	10	10	9	7	5	4	3	3	7	6	8	11	12	15	16
10	10	10	10	9	7	5	4	3	3	7	6	8	11	12	15	16
10	10	10	10	9	7	5	4	3	3	7	6	8	11	12	15	16
10	10	10	10	9	7	5	4	3	3	7	6	8	11	12	15	16
10	10	10	10	9	7	5	4	3	3	7	6	8	11	12	15	16
10	10	10	10	9	7	5	4	3	3	7	6	8	11	12	15	16
10	10	10	10	9	7	5	4	3	3	7	6	8	11	12	15	16
10	10	10	10	9	7	5	4	3	3	7	6	8	11	12	15	16
10	10	10	10	9	7	5	4	3	3	7	6	8	11	12	15	16

SPEC 5.1

NIF BULKHEAD SHELL

0 _____ 36
SCALE

FIG. 90

DISPLAY= SY /1000 , NODE= 1 , SURFACE= 0

6	5	5	5	5	5	4	3	3	3	3	3	5	8	8	8	8
5	5	5	5	5	5	4	3	3	3	3	3	5	8	8	8	8
5	5	5	5	5	5	4	3	3	3	3	3	5	8	8	8	8
5	5	5	5	5	5	4	3	3	3	3	3	5	8	8	8	8
5	5	5	5	5	5	4	3	3	3	3	3	5	8	8	8	8
5	5	5	5	5	5	4	3	3	3	3	3	5	8	8	8	8
5	5	5	5	5	5	4	3	3	3	3	3	5	8	8	8	8
5	5	5	5	5	5	4	3	3	3	3	3	5	8	8	8	8
5	5	5	5	5	5	4	3	3	3	3	3	5	8	8	8	8
5	5	5	5	5	5	4	3	3	3	3	3	5	8	8	8	8
5	5	5	5	5	5	4	3	3	3	3	3	5	8	8	8	8
5	5	5	5	5	5	4	3	3	3	3	3	5	8	8	8	8
5	5	5	5	5	5	4	3	3	3	3	3	5	8	8	8	8
5	5	5	5	5	5	4	3	3	3	3	3	5	8	8	8	8
5	5	5	5	5	5	4	3	3	3	3	3	5	8	8	8	8
5	5	5	5	5	5	4	3	3	3	3	3	5	8	8	8	8
5	5	5	5	5	5	4	3	3	3	3	3	5	8	8	8	8
5	5	5	5	5	5	4	3	3	3	3	3	5	8	8	8	8
5	5	5	5	5	5	4	3	3	3	3	3	5	8	8	8	8
5	5	5	5	5	5	4	3	3	3	3	3	5	8	8	8	8
5	5	5	5	5	5	4	3	3	3	3	3	5	8	8	8	8
5	5	5	5	5	5	4	3	3	3	3	3	5	8	8	8	8
5	5	5	5	5	5	4	3	3	3	3	3	5	8	8	8	8
5	5	5	5	5	5	4	3	3	3	3	3	5	8	8	8	8
5	5	5	5	5	5	4	3	3	3	3	3	5	8	8	8	8
5	5	5	5	5	5	4	3	3	3	3	3	5	8	8	8	8
5	5	5	5	5	5	4	3	3	3	3	3	5	8	8	8	8
5	5	5	5	5	5	4	3	3	3	3	3	5	8	8	8	8
5	5	5	5	5	5	4	3	3	3	3	3	5	8	8	8	8

SPEC 3.1

NIF BULKHEAD SHELL

0 SCALE 36

ORIGINAL PAGE IS OF POOR QUALITY

FIG 91

1/1/1

DISPLAY= SY /1000 , NODE= 1 , SURFACE= 1

5	6	4	3	4	5	6	6	7	7	7	6	-3	0	7	10	10	8
5	5	4	3	4	5	6	6	7	7	7	6	-3	0	7	10	10	8
5	5	4	3	4	5	6	6	7	7	7	6	-3	0	7	10	10	8
5	5	4	3	4	5	6	6	7	7	7	6	-3	0	7	10	10	8
5	5	4	3	4	5	6	6	7	7	7	6	-3	0	7	10	10	8
5	5	4	3	4	5	6	6	7	7	7	6	-3	0	7	10	10	8
5	5	4	3	4	5	6	6	7	7	7	6	-3	0	7	10	10	8
5	5	4	3	4	5	6	6	7	7	7	6	-3	0	7	10	10	8
5	5	4	3	4	5	6	6	7	7	7	6	-3	0	7	10	10	8
5	5	4	3	4	5	6	6	7	7	7	6	-3	0	7	10	10	8
5	5	4	3	4	5	6	6	7	7	7	6	-3	0	7	10	10	8
5	5	4	3	4	5	6	6	7	7	7	6	-3	0	7	10	10	8
5	5	4	3	4	5	6	6	7	7	7	6	-3	0	7	10	10	8
5	5	4	3	4	5	6	6	7	7	7	6	-3	0	7	10	10	8
5	5	4	3	4	5	6	6	7	7	7	6	-3	0	7	10	10	8
5	5	4	3	4	5	6	6	7	7	7	6	-3	0	7	10	10	8
5	5	4	3	4	5	6	6	7	7	7	6	-3	0	7	10	10	8
5	5	4	3	4	5	6	6	7	7	7	6	-3	0	7	10	10	8
5	5	4	3	4	5	6	6	7	7	7	6	-3	0	7	10	10	8
5	5	4	3	4	5	6	6	7	7	7	6	-3	0	7	10	10	8
5	5	4	3	4	5	6	6	7	7	7	6	-3	0	7	10	10	8
5	5	4	3	4	5	6	6	7	7	7	6	-3	0	7	10	10	8
5	5	4	3	4	5	6	6	7	7	7	6	-3	0	7	10	10	8
5	5	4	3	4	5	6	6	7	7	7	6	-3	0	7	10	10	8
5	5	4	3	4	5	6	6	7	7	7	6	-3	0	7	10	10	8
5	5	4	3	4	5	6	6	7	7	7	6	-3	0	7	10	10	8
5	5	4	3	4	5	6	6	7	7	7	6	-3	0	7	10	10	8
5	5	4	3	4	5	6	6	7	7	7	6	-3	0	7	10	10	8
5	5	4	3	4	5	6	6	7	7	7	6	-3	0	7	10	10	8

SPEC
5.1

NTF BULKHEAD
SHELL

0 SCALE 36

FIG 92

1/1/1

DISPLAY= SY /1000 , NODE= 1 , SURFACE= 2

5	5	6	7	6	5	2	1	0	0	0	13	9	9	8	5	5	7
5	5	6	7	6	5	2	1	0	0	0	13	9	9	8	5	5	7
5	5	6	7	6	5	2	1	0	0	0	13	9	9	8	5	5	7
5	5	6	7	6	5	2	1	0	0	0	13	9	9	8	5	5	7
5	5	6	7	6	5	2	1	0	0	0	13	9	9	8	5	5	7
5	5	6	7	6	5	2	1	0	0	0	13	9	9	8	5	5	7
5	5	6	7	6	5	2	1	0	0	0	13	9	9	8	5	5	7
5	5	6	7	6	5	2	1	0	0	0	13	9	9	8	5	5	7
6	6	6	7	6	5	2	1	0	0	0	13	9	9	8	6	6	7
5	5	6	7	6	5	2	1	0	0	0	13	9	9	8	5	5	7
5	5	6	7	6	5	2	1	0	0	0	13	9	9	8	5	5	7
5	5	6	7	6	5	2	1	0	0	0	13	9	9	8	5	5	7
5	5	6	7	6	5	2	1	0	0	0	13	9	9	8	5	5	7
5	6	6	7	6	5	2	1	0	0	0	13	9	9	8	5	5	7
5	6	6	7	6	5	2	1	0	0	0	13	9	9	8	5	5	7
5	5	6	7	6	5	2	1	0	0	0	13	9	9	8	5	6	7
5	5	6	7	6	5	2	1	0	0	0	13	9	9	8	5	6	7
5	5	6	7	6	5	2	1	0	0	0	13	9	9	8	5	6	7
6	5	6	7	6	5	2	1	0	0	0	13	9	9	8	5	6	7
5	5	6	7	6	5	2	1	0	0	0	13	9	9	8	5	6	7
5	5	6	7	6	5	2	1	0	0	0	13	9	9	8	5	6	7
5	5	6	7	6	5	2	1	0	0	0	13	9	9	8	5	6	7
6	5	6	7	6	5	2	1	0	0	0	13	9	9	8	5	6	7
5	5	6	7	6	5	2	1	0	0	0	13	9	9	8	5	6	7
5	5	6	7	6	5	2	1	0	0	0	13	9	9	8	5	6	7
5	5	6	7	6	5	2	1	0	0	0	13	9	9	8	5	6	7
5	5	6	7	6	5	2	1	0	0	0	13	9	9	8	5	6	7
5	5	6	7	6	5	2	1	0	0	0	13	9	9	8	5	6	7
5	5	6	7	6	5	2	1	0	0	0	13	9	9	8	5	6	7
5	5	6	7	6	5	2	1	0	0	0	13	9	9	8	5	6	7
5	5	6	7	6	5	2	1	0	0	0	13	9	9	8	5	6	7
5	5	6	7	6	5	2	1	0	0	0	13	9	9	8	5	6	7
5	5	6	7	6	5	2	1	0	0	0	13	9	9	8	5	6	7
5	5	6	7	6	5	2	1	0	0	0	13	9	9	8	5	6	7
5	5	6	7	6	5	2	1	0	0	0	13	9	9	8	5	6	7

SPEC
5.1

NTF BULKHEAD
SHELL

0 SCALE 36

ORIGINAL PAGE IS
OF POOR QUALITY

FIG 93

1/1/1

DISPLAY= SX /1000 , NODE= 1 , SURFACE= 0

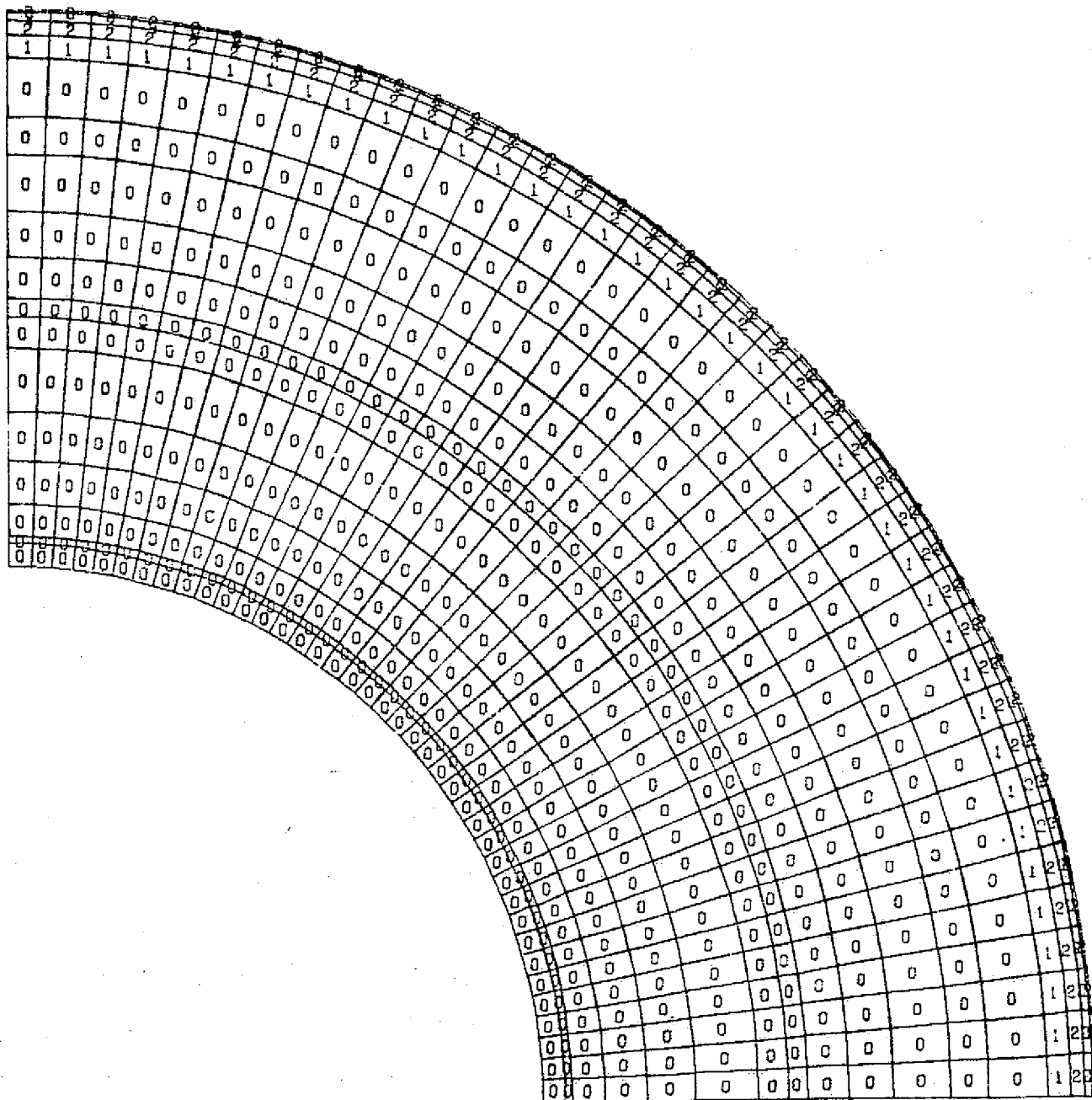

SPEC
3.1

NTF BULKHEAD
DOME

0 SCALE 26

FIG 94

DISPLAY= SX /1000 , NODE= 1 , SURFACE= 1

1/1/1

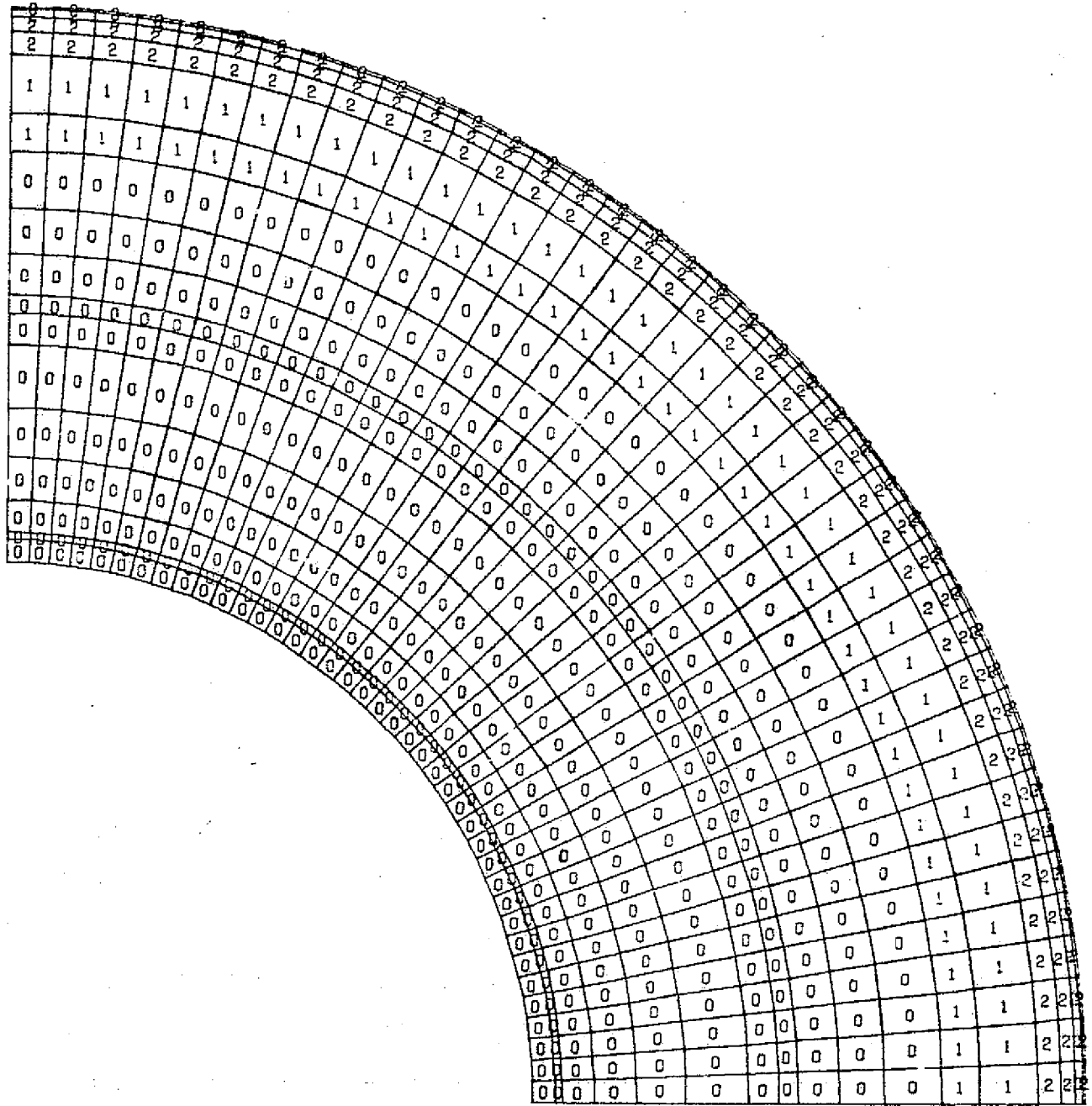

SPEC
3.1

NTF BULKHEAD
DOME

0 SCALE 26

ORIGINAL PAGE IS
OF POOR QUALITY

FIG 95

DISPLAY= SX /1000 , NODE= 1, SURFACE= 2

1/1/1

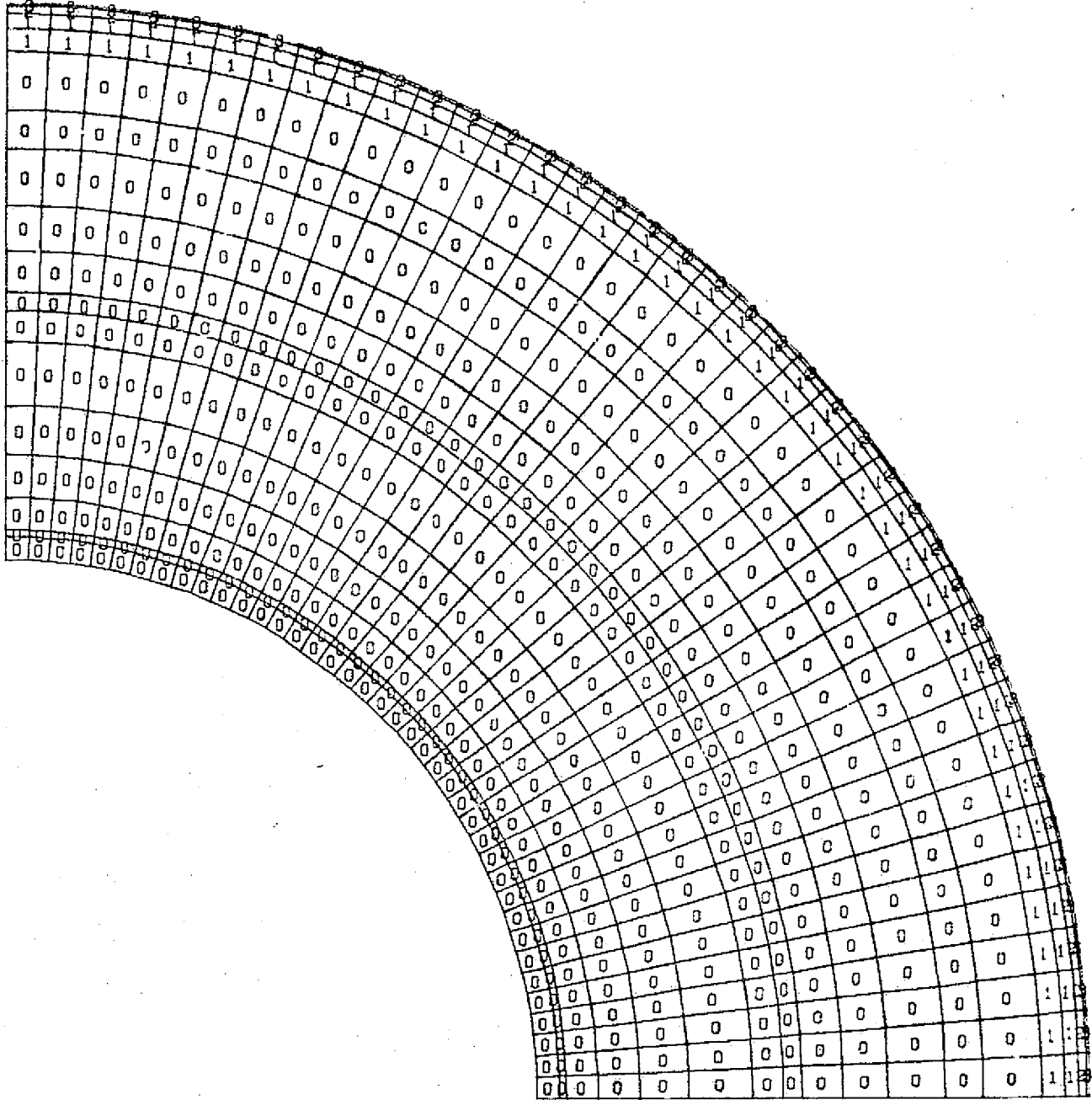

SPEC
3.1

NTF BULKHEAD
DOME

0 SCALE 26

FIG. 96

DISPLAY= SY /1000 , NODE= 1. SURFACE= 0

1/1/1

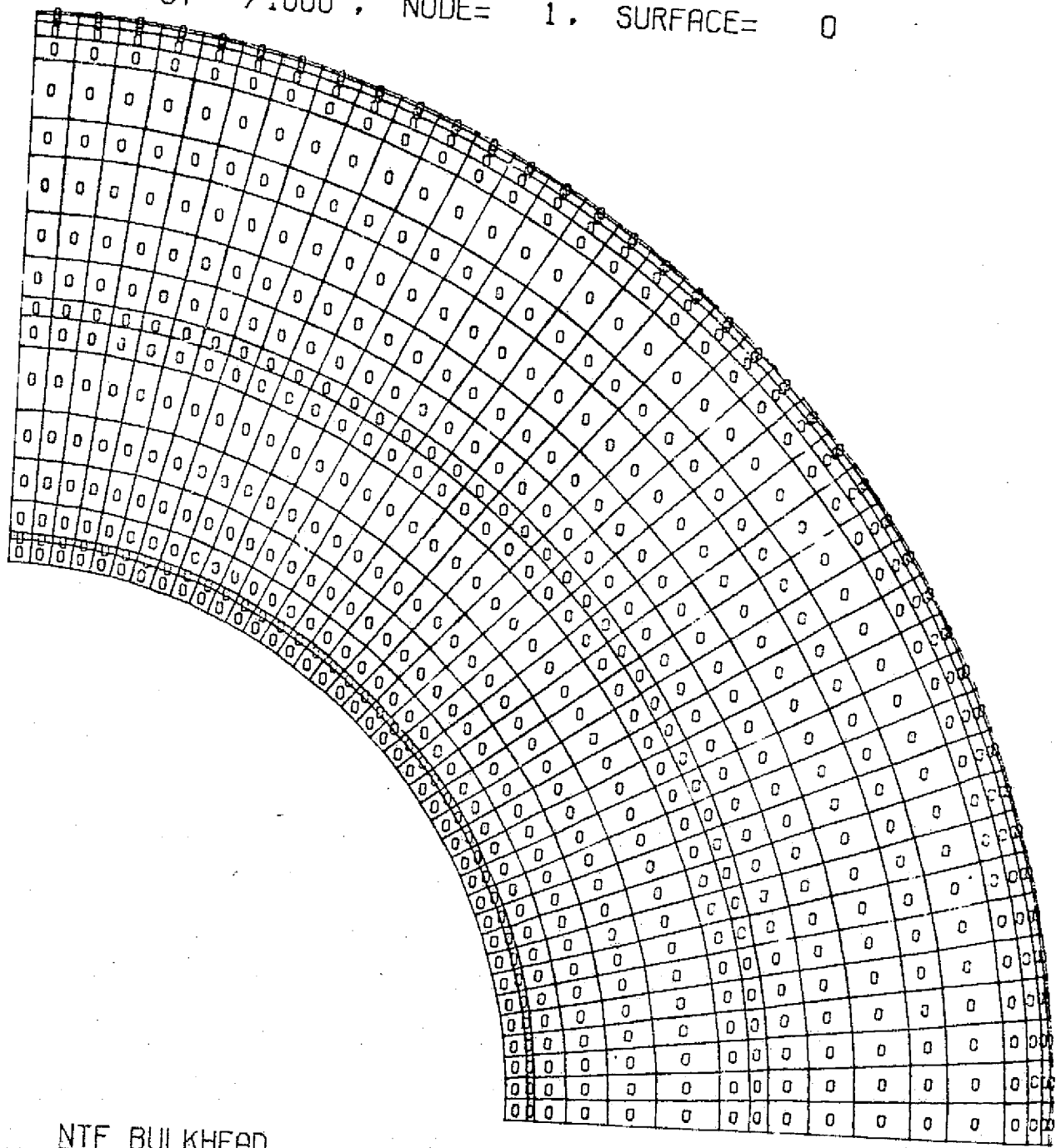

SPEC
3.1

NTF BULKHEAD
DOME

0 SCALE 26

ORIGINS: PLSH 1
OF FACE QUALITY

FIG 97

DISPLAY= SY /1000 , NODE= 1 , SURFACE= 1

1/1/1

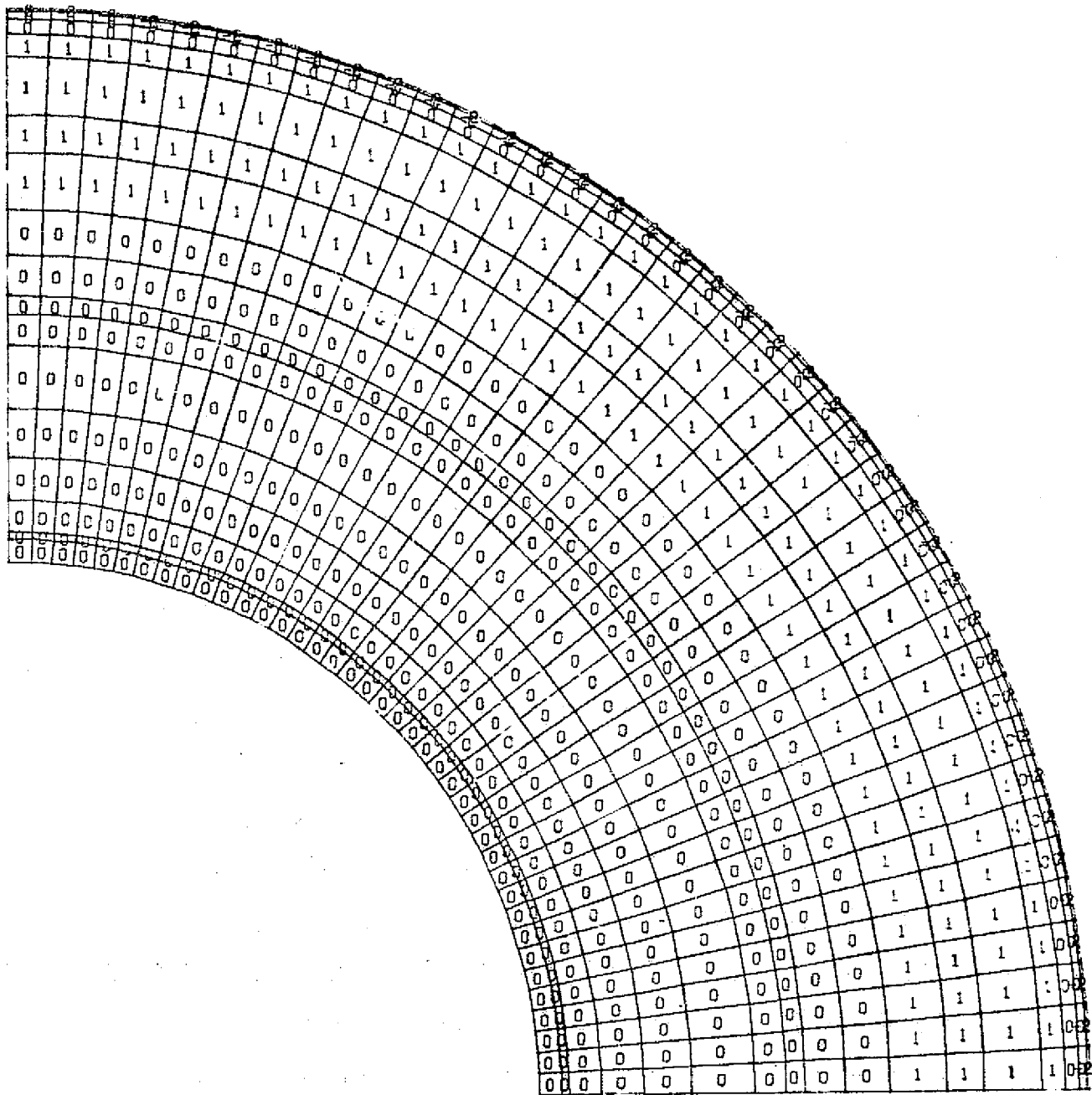

SPEC
3.1

NTF BULKHEAD
DOME

0 SCALE 26

FIG 98

1/1/1

DISPLAY= SY /1000 , NODE= 1 , SURFACE= 2

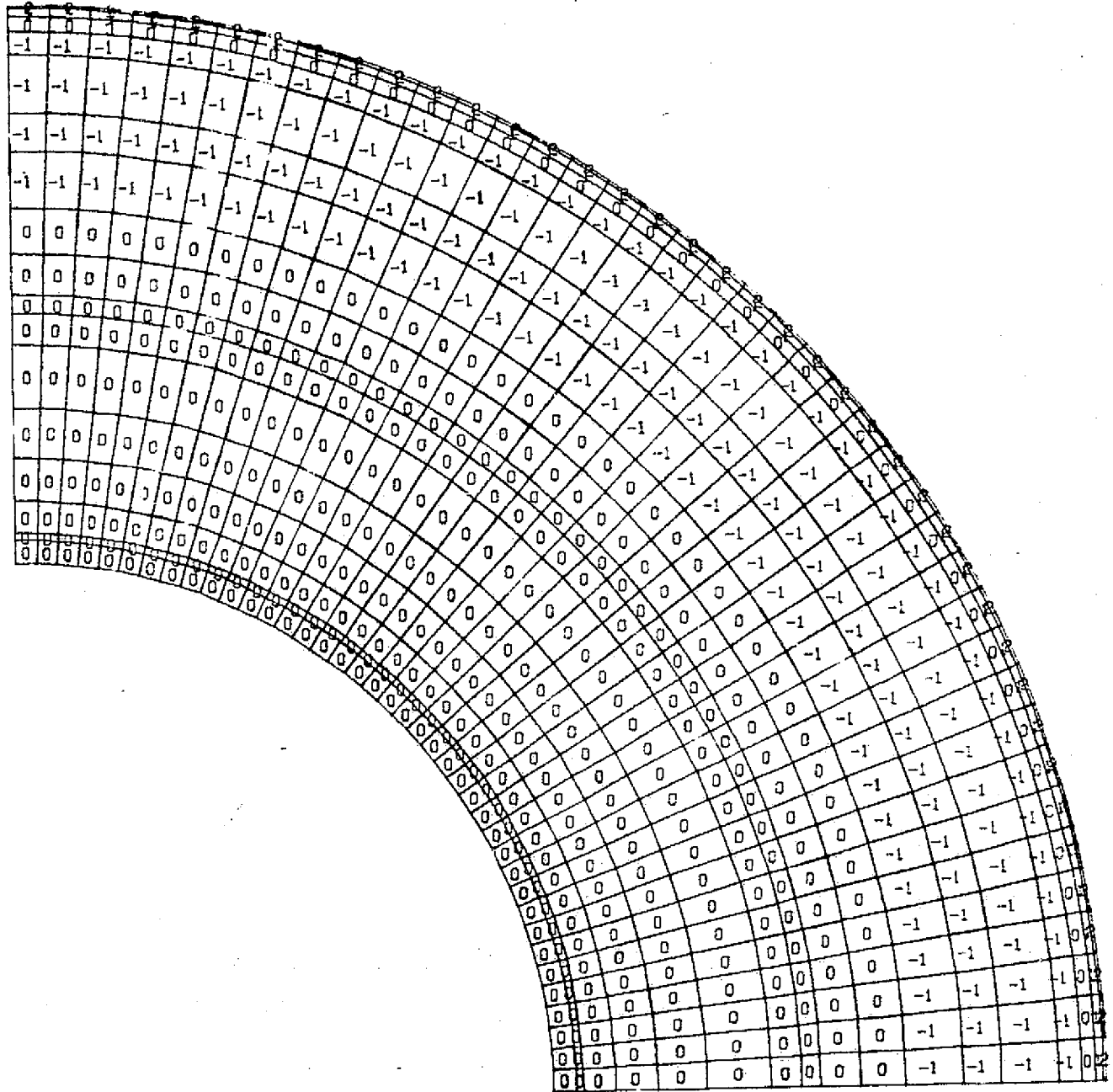

SPEC
7.1

NTF BULKHEAD
DOME

0 SCALE 26

ORIGINAL DRAWING
OF THIS PROJECT

FIG 99

DISPLAY= SX /1000 , NODE= 1, SURFACE= 1

1/1/1

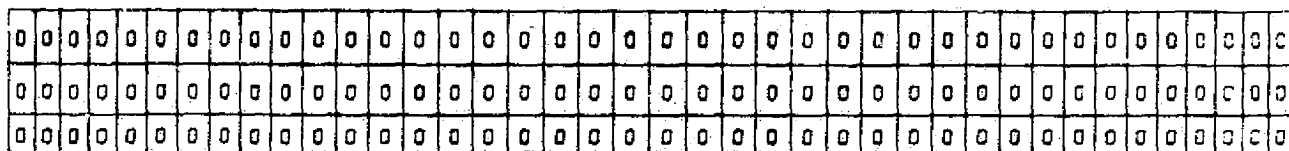

SPEC
10.1

NTF BULKHEAD
HATCH OPENING

0 SCALE 18

FIG 101

DISPLAY= SX /1000 , NODE= 1 , SURFACE= 2

1/1/1

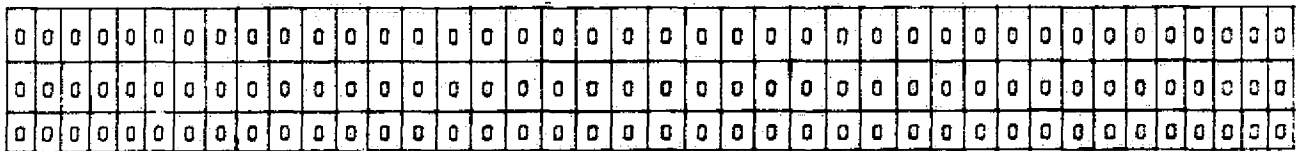

SPEC
0.1

NTF BULKHEAD
HATCH OPENING

0 ———— 18
SCALE

FIG 102

DISPLAY= SX /1000 , NODE= 1, SURFACE= 0

1/1/1

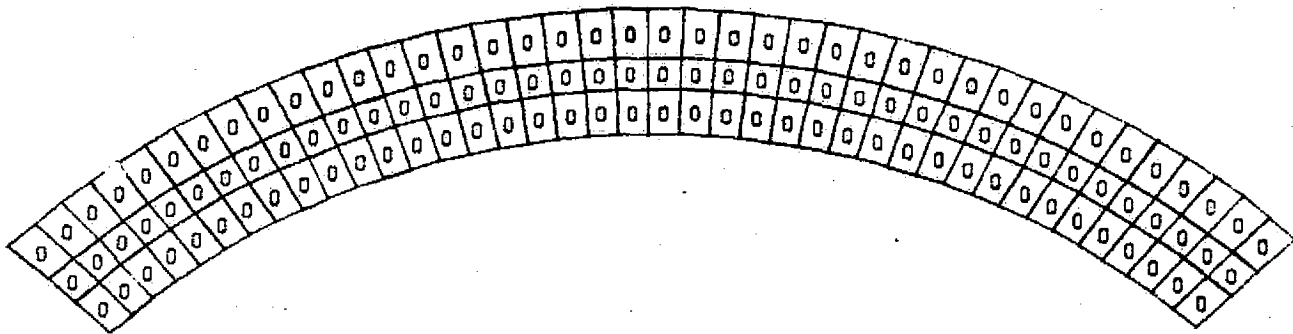

SPEC
2.1

NTF BULKHEAD
FLANGE SURFACE

0 ——— 21
SCALE

FIG 106

DISPLAY= SX /1000 , NODE= 1 , SURFACE= 1 1/1/1

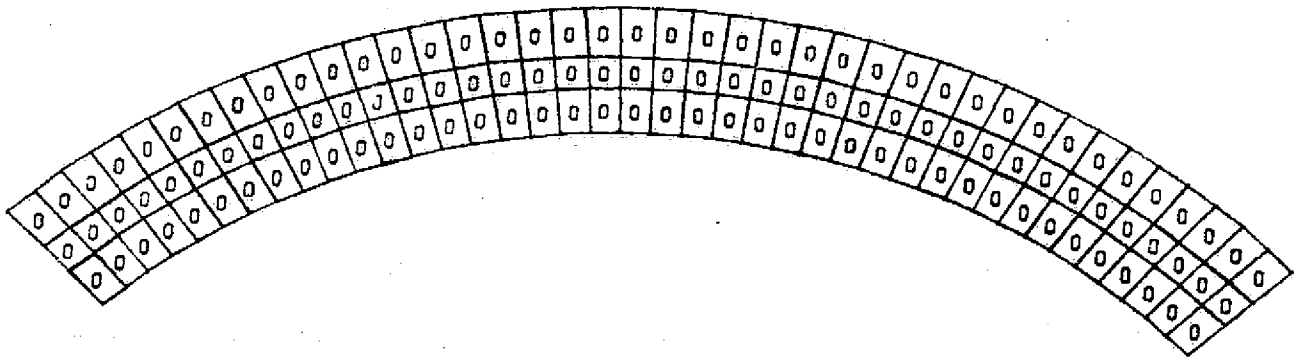

SPEC
2.1

NTF BULKHEAD
FLANGE SURFACE

0 SCALE 21

FIG 107

DISPLAY= SX /1000 , NODE= 1, SURFACE= 2

1/1/1

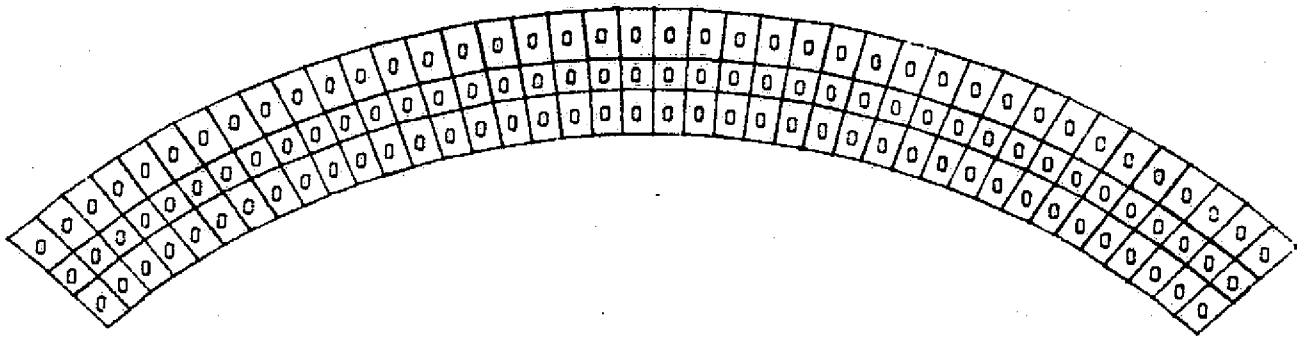

SPEC
2.1

NTF BULKHEAD
FLANGE SURFACE

0 ——— 21
SCALE

FIG 108

DISPLAY= SY /1000 , NODE= 1, SURFACE= 0

1/1/1

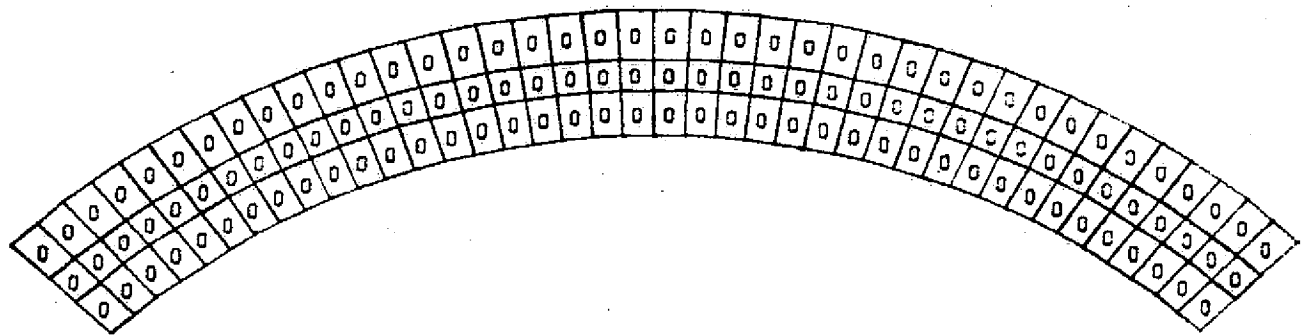

SPEC
2.1

NTF BULKHEAD
FLANGE SURFACE

0 SCALE 21

FIG 109

DISPLAY= SY /1000 , NCDE= 1 , SURFACE= 1

1/1/1

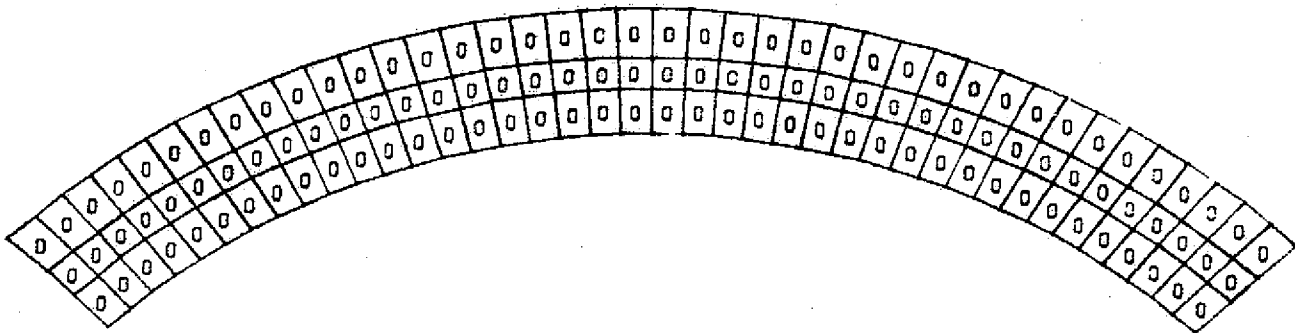

SPEC
2.1

NTF BULKHEAD
FLANGE SURFACE

0 ——— 21
SCALE

FIG 110

DISPLAY= SY /1000 , NODE= 1, SURFACE= 2

1/1/1

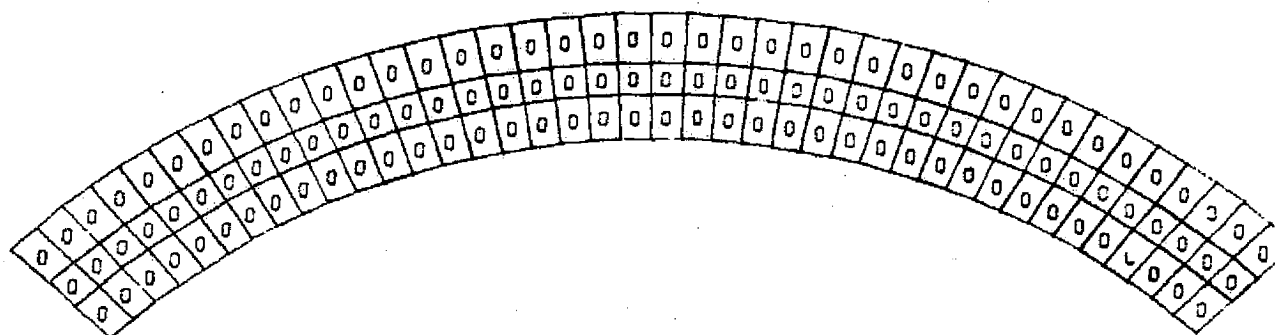

**ORIGINAL PAGE IS
OF POOR QUALITY**

SPEC
2.1

NTF BULKHEAD
FLANGE SURFACE

0 _____ 21
SCALE

FIG III

1/1/1

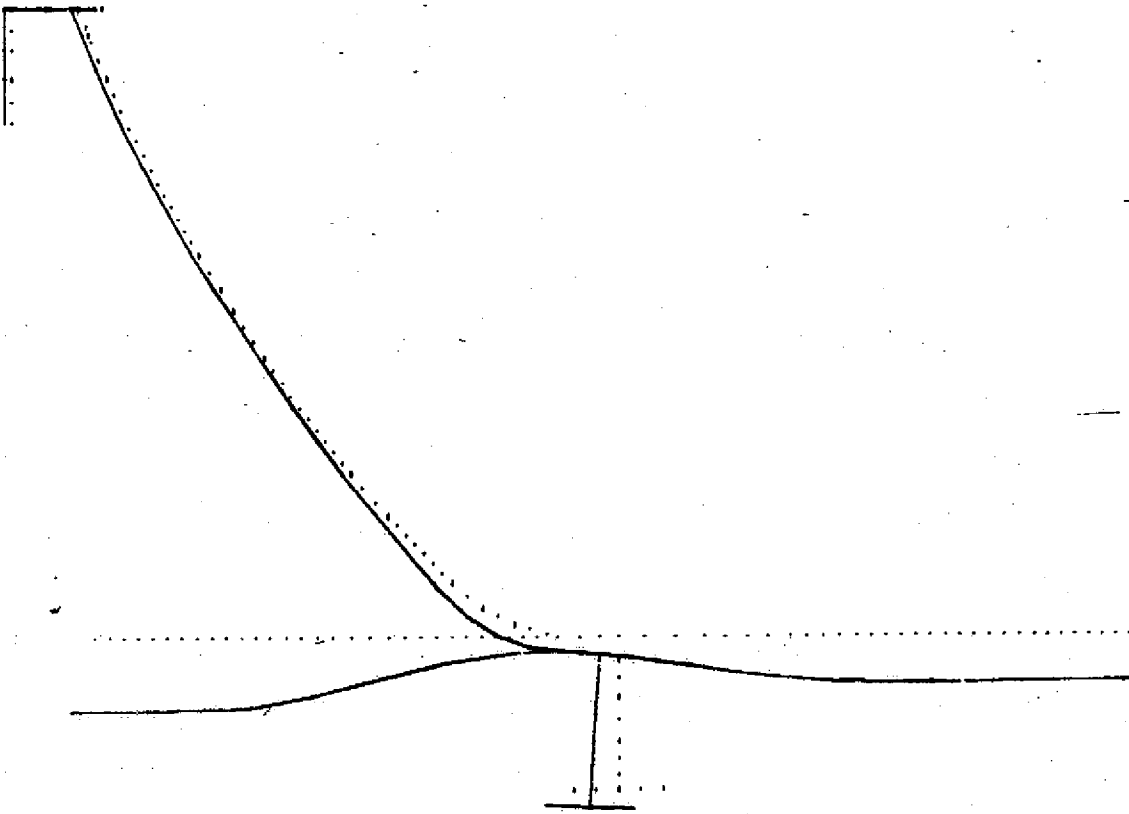

SPEC
12.1

NTF BULKHEAD
CROSS-SECTION VIEW

0 27
SCALE

FIG 112

1/1/1

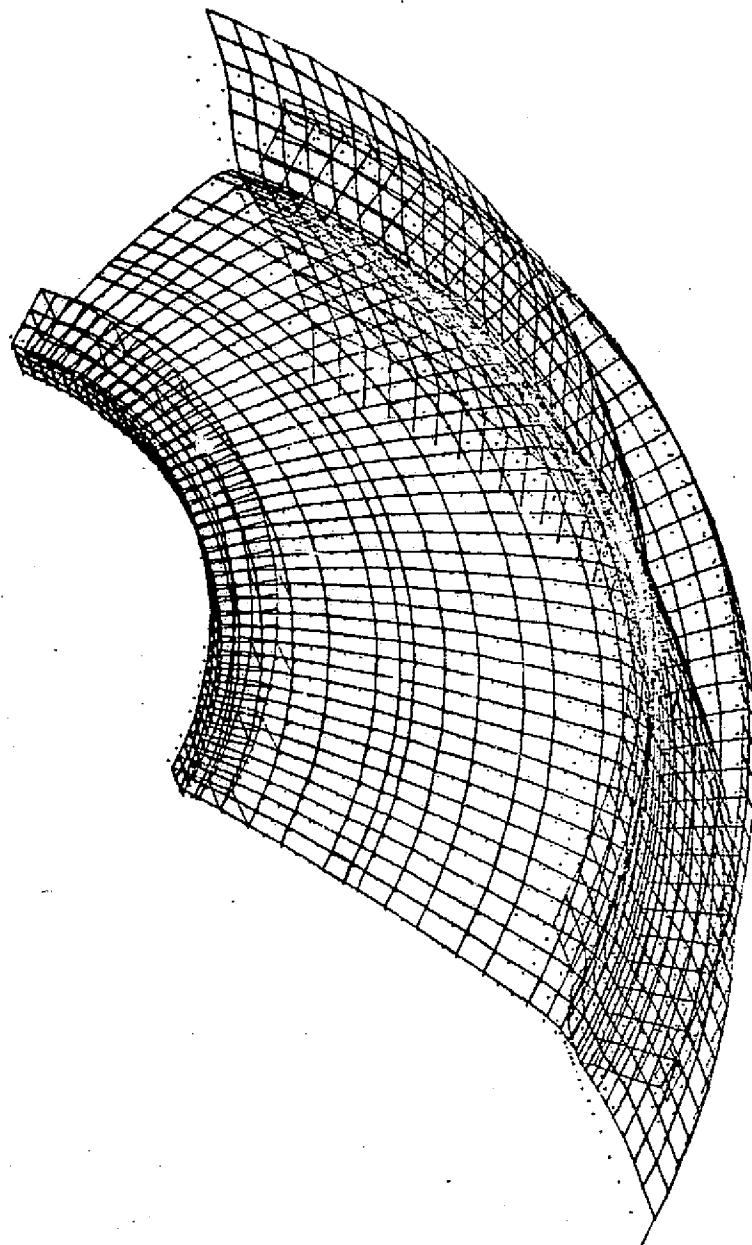

SPEC
1.1

NTF BULKHEAD

0 ——— 44
SCALE

FIG 113

CASE 4

GATE VALVE OPEN
W/ STEADY STATE TEMP. PROFILE.

STRESS PLOTS

FIGURES 114 THRU 140

COMPUTER RUN NO. LAD

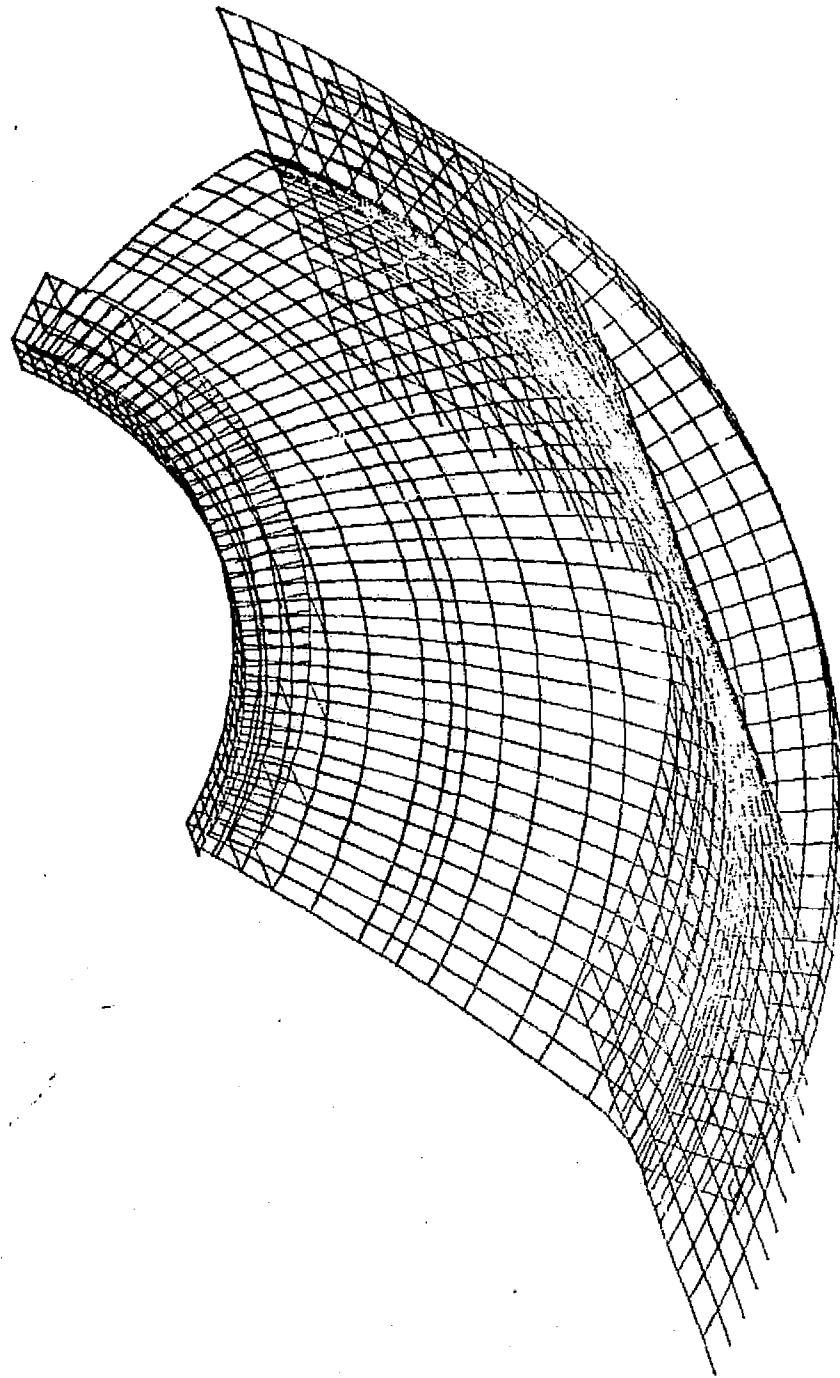

SPEC
1.1

N.T.E BULKHEAD

0 SCALE 41

FIG. 114

DISPLAY= SX /1000 , NODE= 1 , SURFACE= 0

6	6	6	6	8	7	6	4	3	1	3	3	-4	-1	8	7	12	18
5	5	6	6	8	7	6	4	3	1	3	3	-4	-1	8	7	12	18
6	5	6	6	8	7	6	4	3	1	3	3	-4	-1	8	7	12	18
5	5	6	6	8	7	6	4	3	1	3	3	-4	-1	8	7	12	18
6	6	6	6	8	7	6	4	3	1	3	3	-4	-1	8	7	12	18
5	5	6	6	8	7	6	4	3	1	3	3	-4	-1	8	7	12	18
6	6	6	6	8	7	6	4	3	1	3	3	-4	-1	8	7	12	18
5	5	6	6	8	7	6	4	3	1	3	3	-4	-1	8	7	12	18
6	6	6	6	8	7	6	4	3	1	3	3	-4	-1	8	7	12	18
5	5	6	6	8	7	6	4	3	1	3	3	-4	-1	8	7	12	18
6	6	6	6	8	7	6	4	3	1	3	3	-4	-1	8	7	12	18
5	5	6	6	8	7	6	4	3	1	3	3	-4	-1	8	7	12	18
6	6	6	6	8	7	6	4	3	1	3	3	-4	-1	8	7	12	18
5	5	6	6	8	7	6	4	3	1	3	3	-4	-1	8	7	12	18
6	6	6	6	8	7	6	4	3	1	3	3	-4	-1	8	7	12	18
5	5	6	6	8	7	6	4	3	1	3	3	-4	-1	8	7	12	18
6	6	6	6	8	7	6	4	3	1	3	3	-4	-1	8	7	12	18
5	5	6	6	8	7	6	4	3	1	3	3	-4	-1	8	7	12	18
6	6	6	6	8	7	6	4	3	1	3	3	-4	-1	8	7	12	18
5	5	6	6	8	7	6	4	3	1	3	3	-4	-1	8	7	12	18
6	6	6	6	8	7	6	4	3	1	3	3	-4	-1	8	7	12	18
5	5	6	6	8	7	6	4	3	1	3	3	-4	-1	8	7	12	18
6	6	6	6	8	7	6	4	3	1	3	3	-4	-1	8	7	12	18
5	5	6	6	8	7	6	4	3	1	3	3	-4	-1	8	7	12	18
6	6	6	6	8	7	6	4	3	1	3	3	-4	-1	8	7	12	18
5	5	6	6	8	7	6	4	3	1	3	3	-4	-1	8	7	12	18
6	6	6	6	8	7	6	4	3	1	3	3	-4	-1	8	7	12	18
5	5	6	6	8	7	6	4	3	1	3	3	-4	-1	8	7	12	18
6	6	6	6	8	7	6	4	3	1	3	3	-4	-1	8	7	12	18
5	5	6	6	8	7	6	4	3	1	3	3	-4	-1	8	7	12	18
6	6	6	6	8	7	6	4	3	1	3	3	-4	-1	8	7	12	18
5	5	6	6	8	7	6	4	3	1	3	3	-4	-1	8	7	12	18
6	6	6	6	8	7	6	4	3	1	3	3	-4	-1	8	7	12	18
5	5	6	6	8	7	6	4	3	1	3	3	-4	-1	8	7	12	18
6	6	6	6	8	7	6	4	3	1	3	3	-4	-1	8	7	12	18
5	5	6	6	8	7	6	4	3	1	3	3	-4	-1	8	7	12	18
6	6	6	6	8	7	6	4	3	1	3	3	-4	-1	8	7	12	18
5	5	6	6	8	7	6	4	3	1	3	3	-4	-1	8	7	12	18
6	6	6	6	8	7	6	4	3	1	3	3	-4	-1	8	7	12	18
5	5	6	6	8	7	6	4	3	1	3	3	-4	-1	8	7	12	18

SPEC 5.1

NTF BULKHEAD SHELL

0 SCALE 36

FIG 115

DISPLAY= SX /1000 , NODE= 1 , SURFACE= 1

6	6	6	6	7	5	4	2	0	2	0	8	-12	-6	7	9	14	18
5	5	6	6	7	5	4	2	0	2	0	8	-12	-6	7	9	14	18
6	6	8	6	7	5	4	2	0	2	0	8	-12	-6	7	9	14	18
5	5	6	6	7	5	4	2	0	2	0	8	-12	-6	7	9	14	18
6	6	6	6	7	5	4	2	0	2	0	8	-12	-6	7	9	14	18
5	5	6	8	7	5	4	2	0	2	0	8	-12	-6	7	9	14	18
6	6	8	8	7	5	4	2	0	2	0	8	-12	-6	7	9	14	18
5	5	6	6	7	5	4	2	0	2	0	8	-12	-6	7	9	14	18
6	6	6	6	7	5	4	2	0	2	0	8	-12	-6	7	9	14	18
5	5	8	6	7	5	4	2	0	2	0	8	-12	-6	7	9	14	18
6	6	6	6	7	5	4	2	0	2	0	8	-12	-6	7	9	14	18
5	5	6	8	7	5	4	2	0	2	0	8	-12	-6	7	9	14	18
6	6	8	8	7	5	4	2	0	2	0	8	-12	-6	7	9	14	18
5	5	6	6	7	5	4	2	0	2	0	8	-12	-6	7	9	14	18
6	6	6	6	7	5	4	2	0	2	0	8	-12	-6	7	9	14	18
5	5	8	8	7	5	4	2	0	2	0	8	-12	-6	7	9	14	18
6	6	6	6	7	5	4	2	0	2	0	8	-12	-6	7	9	14	18
5	5	6	8	7	5	4	2	0	2	0	8	-12	-6	7	9	14	18
6	6	8	8	7	5	4	2	0	2	0	8	-12	-6	7	9	14	18
5	5	6	6	7	5	4	2	0	2	0	8	-12	-6	7	9	14	18
6	6	6	6	7	5	4	2	0	2	0	8	-12	-6	7	9	14	18
5	5	8	8	7	5	4	2	0	2	0	8	-12	-6	7	9	14	18
6	6	6	6	7	5	4	2	0	2	0	8	-12	-6	7	9	14	18
5	5	6	8	7	5	4	2	0	2	0	8	-12	-6	7	9	14	18
6	6	8	8	7	5	4	2	0	2	0	8	-12	-6	7	9	14	18
5	5	6	6	7	5	4	2	0	2	0	8	-12	-6	7	9	14	18
6	6	6	6	7	5	4	2	0	2	0	8	-12	-6	7	9	14	18
5	5	8	8	7	5	4	2	0	2	0	8	-12	-6	7	9	14	18
6	6	6	6	7	5	4	2	0	2	0	8	-12	-6	7	9	14	18
5	5	6	8	7	5	4	2	0	2	0	8	-12	-6	7	9	14	18
6	6	8	8	7	5	4	2	0	2	0	8	-12	-6	7	9	14	18

SPEC
5.1

NIF BULKHEAD
SHELL

0 SCALE 36

DISPLAY= SX /100C , NODE= 1 , SURFACE= 2

5	5	6	7	9	10	8	7	6	5	15	3	4	10	4	9	19
5	5	6	7	9	10	8	7	6	5	15	3	4	10	4	9	19
5	5	6	7	9	10	8	7	6	5	15	3	4	10	4	9	19
5	5	6	7	9	10	8	7	6	5	15	3	4	10	4	9	19
5	5	6	7	9	10	8	7	6	5	15	3	4	10	4	9	19
5	5	6	7	9	10	8	7	6	5	15	3	4	10	4	9	19
5	5	6	7	9	10	8	7	6	5	15	3	4	10	4	9	19
5	5	6	7	9	10	8	7	6	5	15	3	4	10	4	9	19
5	5	6	7	9	10	8	7	6	5	15	3	4	10	4	9	19
5	5	6	7	9	10	8	7	6	5	15	3	4	10	4	9	19
5	5	6	7	9	10	8	7	6	5	15	3	4	10	4	9	19
5	5	6	7	9	10	8	7	6	5	15	3	4	10	4	9	19
5	5	6	7	9	10	8	7	6	5	15	3	4	10	4	9	19
5	5	6	7	9	10	8	7	6	5	15	3	4	10	4	9	19
5	5	6	7	9	10	8	7	6	5	15	3	4	10	4	9	19
5	5	6	7	9	10	8	7	6	5	15	3	4	10	4	9	19
5	5	6	7	9	10	8	7	6	5	15	3	4	10	4	9	19
5	5	6	7	9	10	8	7	6	5	15	3	4	10	4	9	19
5	5	6	7	9	10	8	7	6	5	15	3	4	10	4	9	19
5	5	6	7	9	10	8	7	6	5	15	3	4	10	4	9	19
5	5	6	7	9	10	8	7	6	5	15	3	4	10	4	9	19
5	5	6	7	9	10	8	7	6	5	15	3	4	10	4	9	19
5	5	6	7	9	10	8	7	6	5	15	3	4	10	4	9	19
5	5	6	7	9	10	8	7	6	5	15	3	4	10	4	9	19
5	5	6	7	9	10	8	7	6	5	15	3	4	10	4	9	19
5	5	6	7	9	10	8	7	6	5	15	3	4	10	4	9	19
5	5	6	7	9	10	8	7	6	5	15	3	4	10	4	9	19
5	5	6	7	9	10	8	7	6	5	15	3	4	10	4	9	19
5	5	6	7	9	10	8	7	6	5	15	3	4	10	4	9	19
5	5	6	7	9	10	8	7	6	5	15	3	4	10	4	9	19
5	5	6	7	9	10	8	7	6	5	15	3	4	10	4	9	19
5	5	6	7	9	10	8	7	6	5	15	3	4	10	4	9	19
5	5	6	7	9	10	8	7	6	5	15	3	4	10	4	9	19

SPEC 5.1

NTF BULKHEAD SHELL

Q SCALE 36

ORIGINAL PAGE IS OF POOR QUALITY

FIG 117

DISPLAY= SX /1000 , NODE= 1, SURFACE= 0

1/1/1

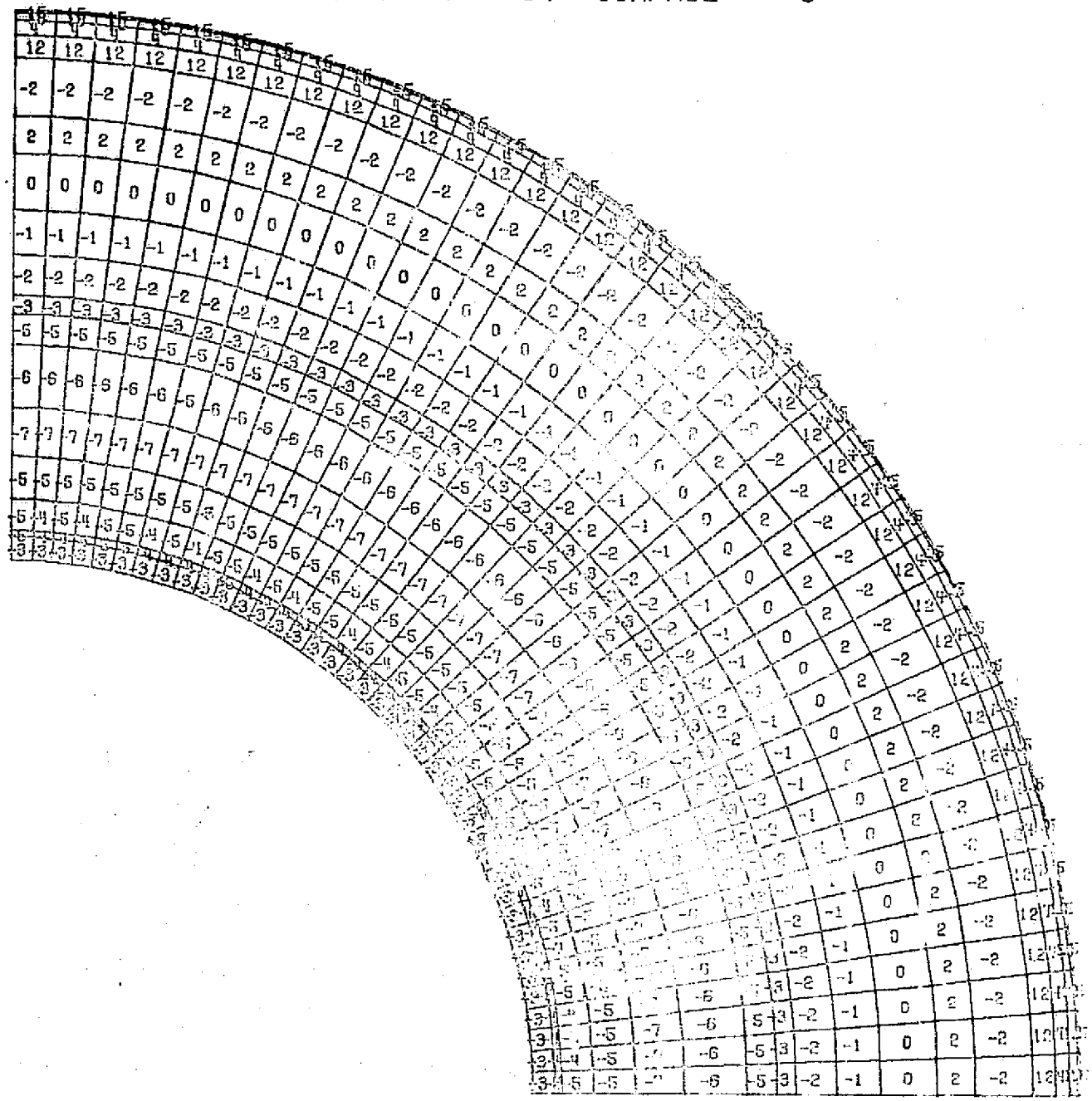

SPEC
3.1

NTF BULKHEAD
DOME

0 SCALE 26

ORIGINAL PAGE IS
OF POOR QUALITY

FIG 121

DISPLAY= SX /1000 , NODL= 1 , SURFACE= 1

1/1/1

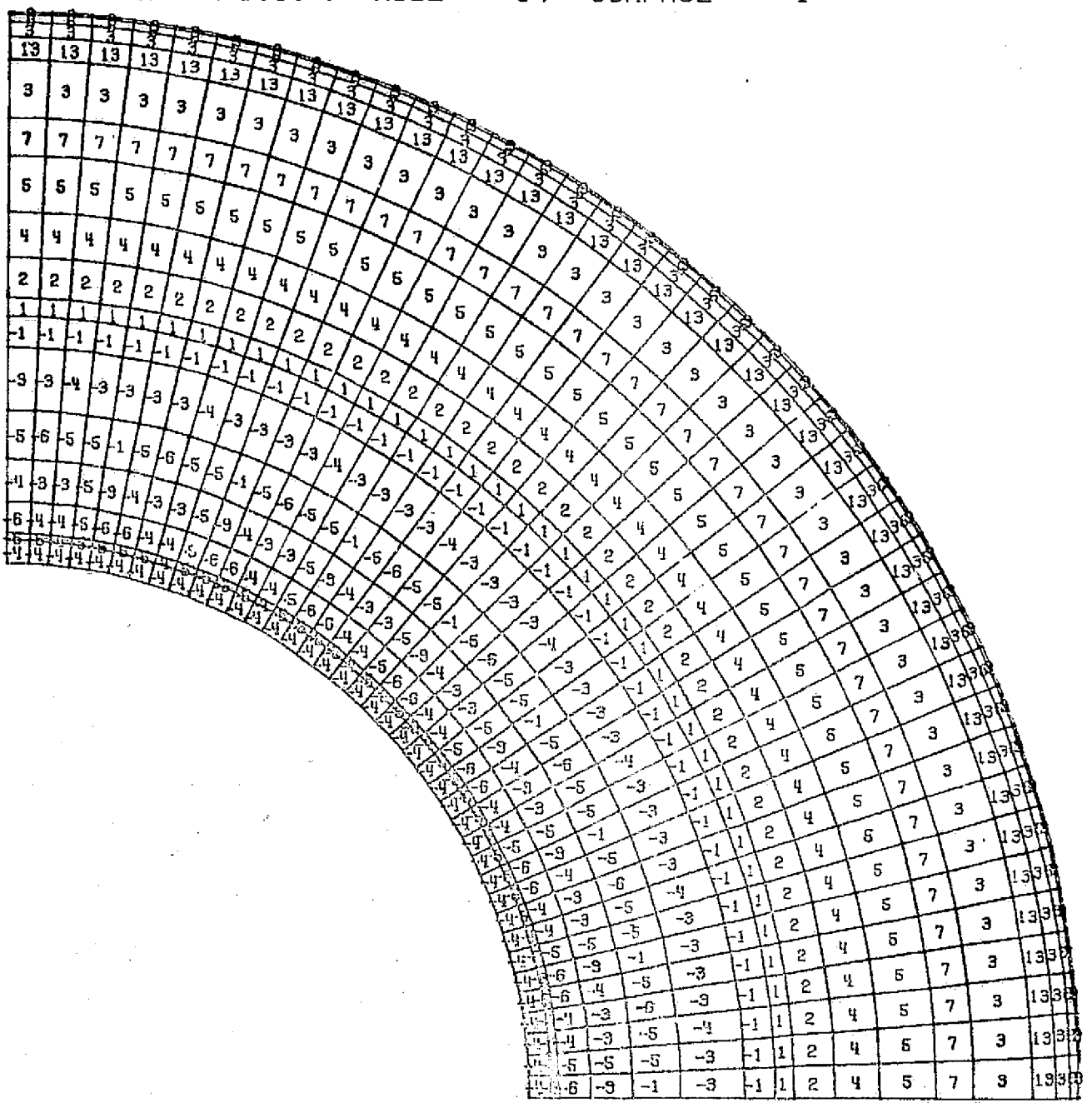

SPEC 3.1 NTF_BULKHEAD DOME

0 SCALE 25

FIG 122

DISPLAY= SX /1000 , NODE= 1, SURFACE= 2

1/1/1

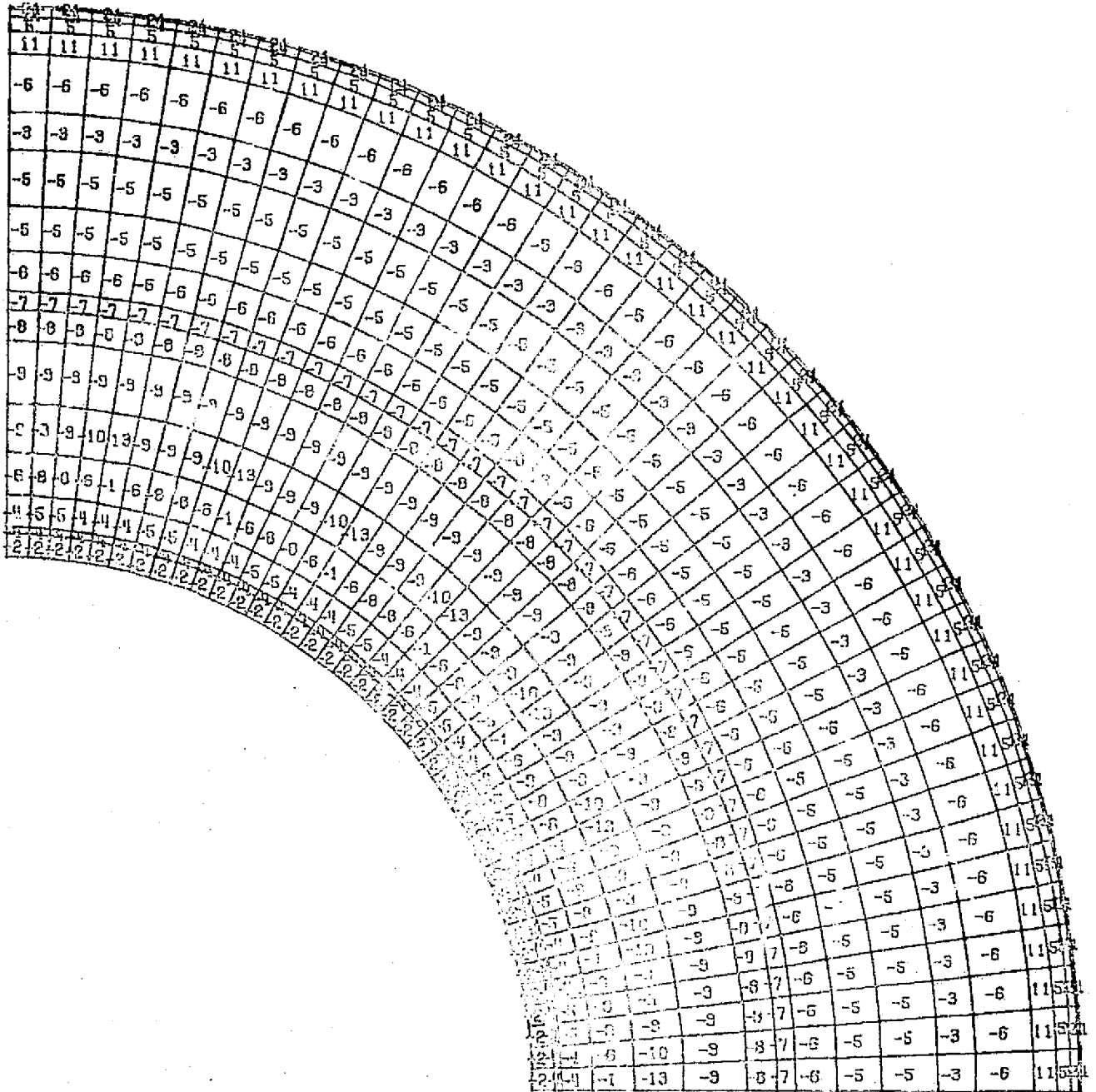

SPEC
3.1

NTF BULKHEAD
DOME

0 SCALE 26

ORIGINAL PAGE IS
OF POOR QUALITY

FIG 123

DISPLAY= SY /1000 , NODE= 1, SURFACE= 0

1/1/1

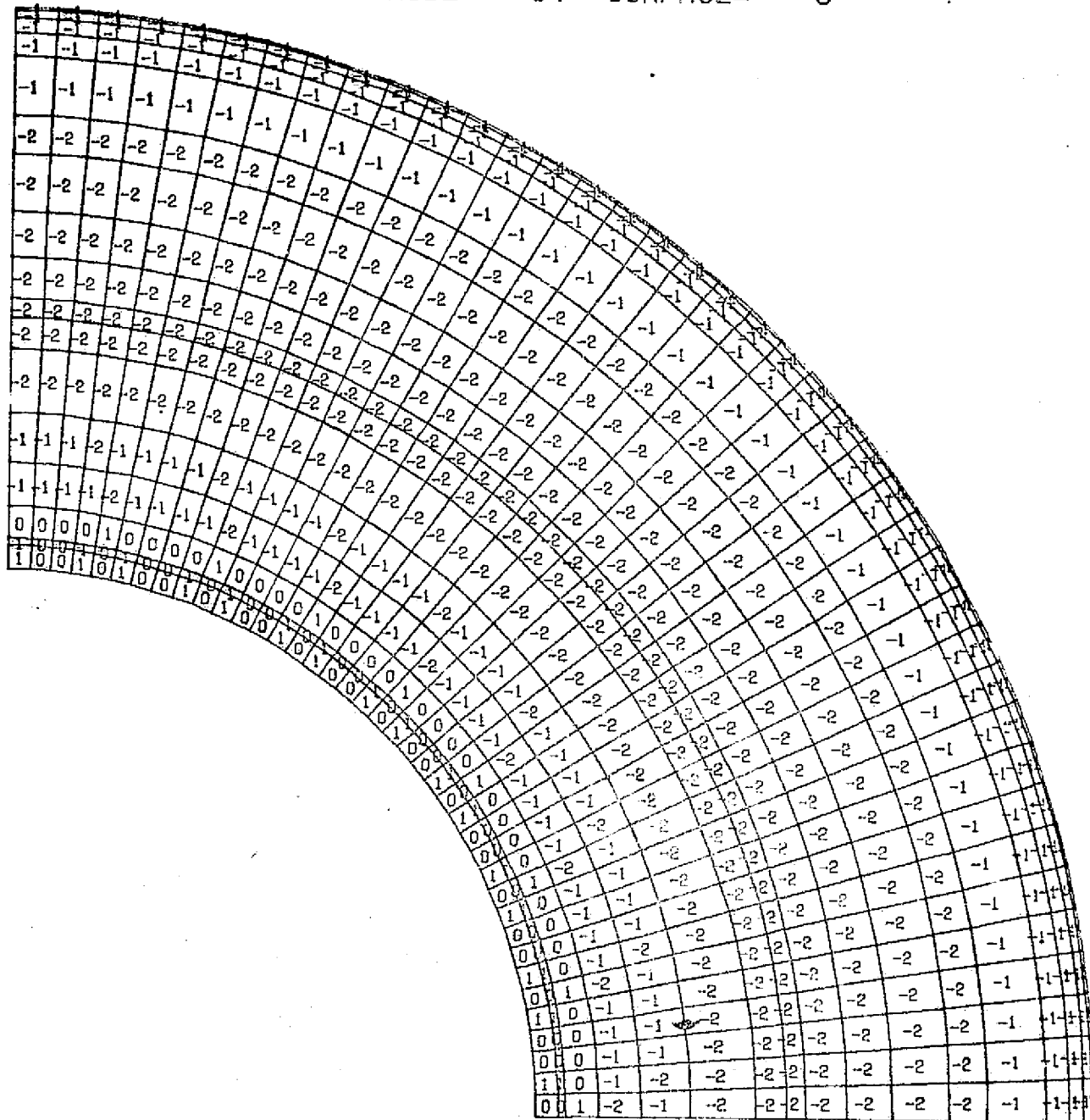

SPEC
3.1

NTF BULKHEAD
DOME

0 SCALE 26

FIG 124

1/1/1

DISPLAY= SY /1000 , NODE= 1, SURFACE= 1

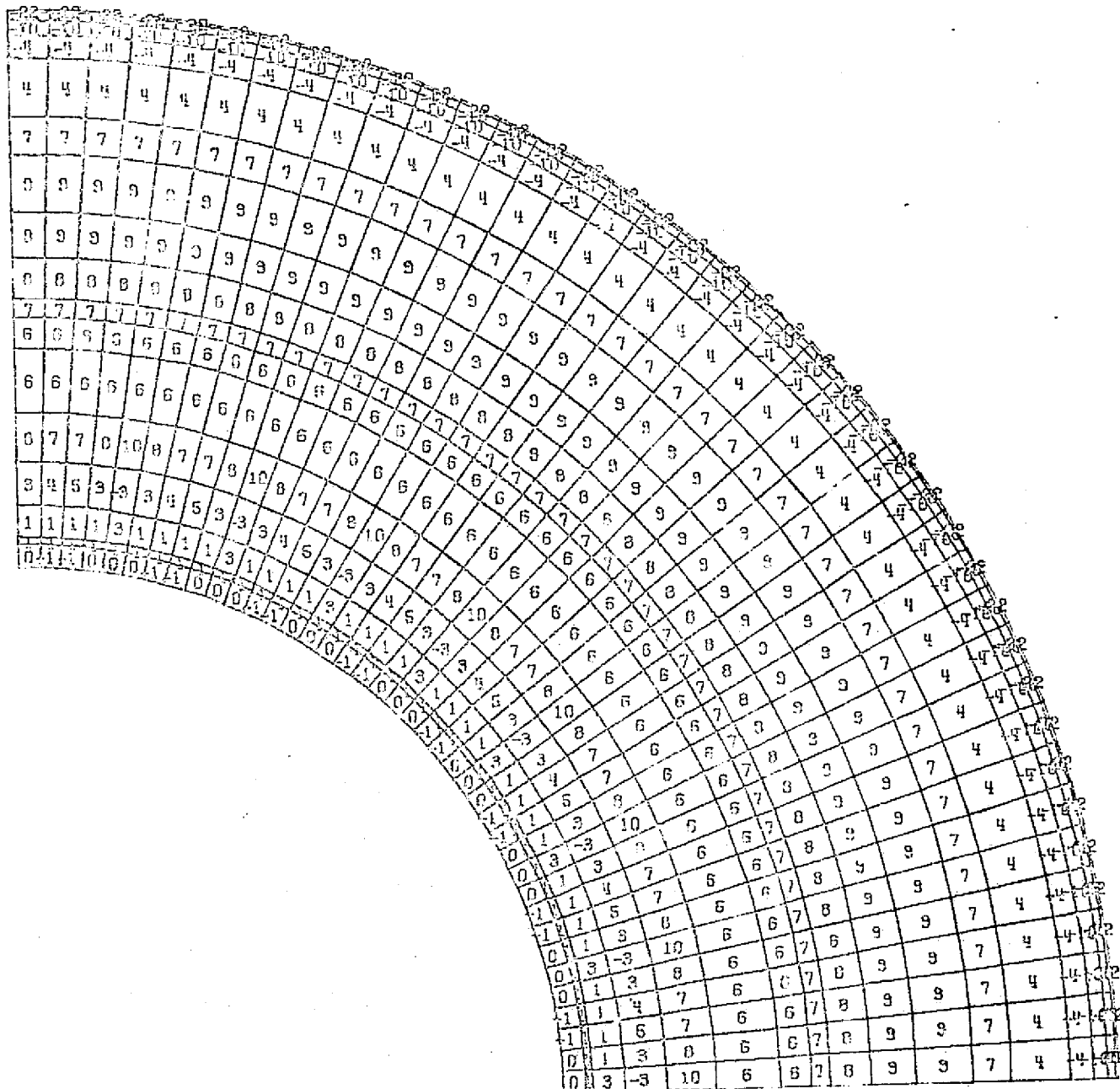

SPEC
3.1

NTF BULKHEAD
DOME

0 SCALE 26

ORIGINAL PAGE IS
OF POOR QUALITY

FIG 125

1/1/1

DISPLAY= SY /1000 , NODE= 1 , SURFACE= 2

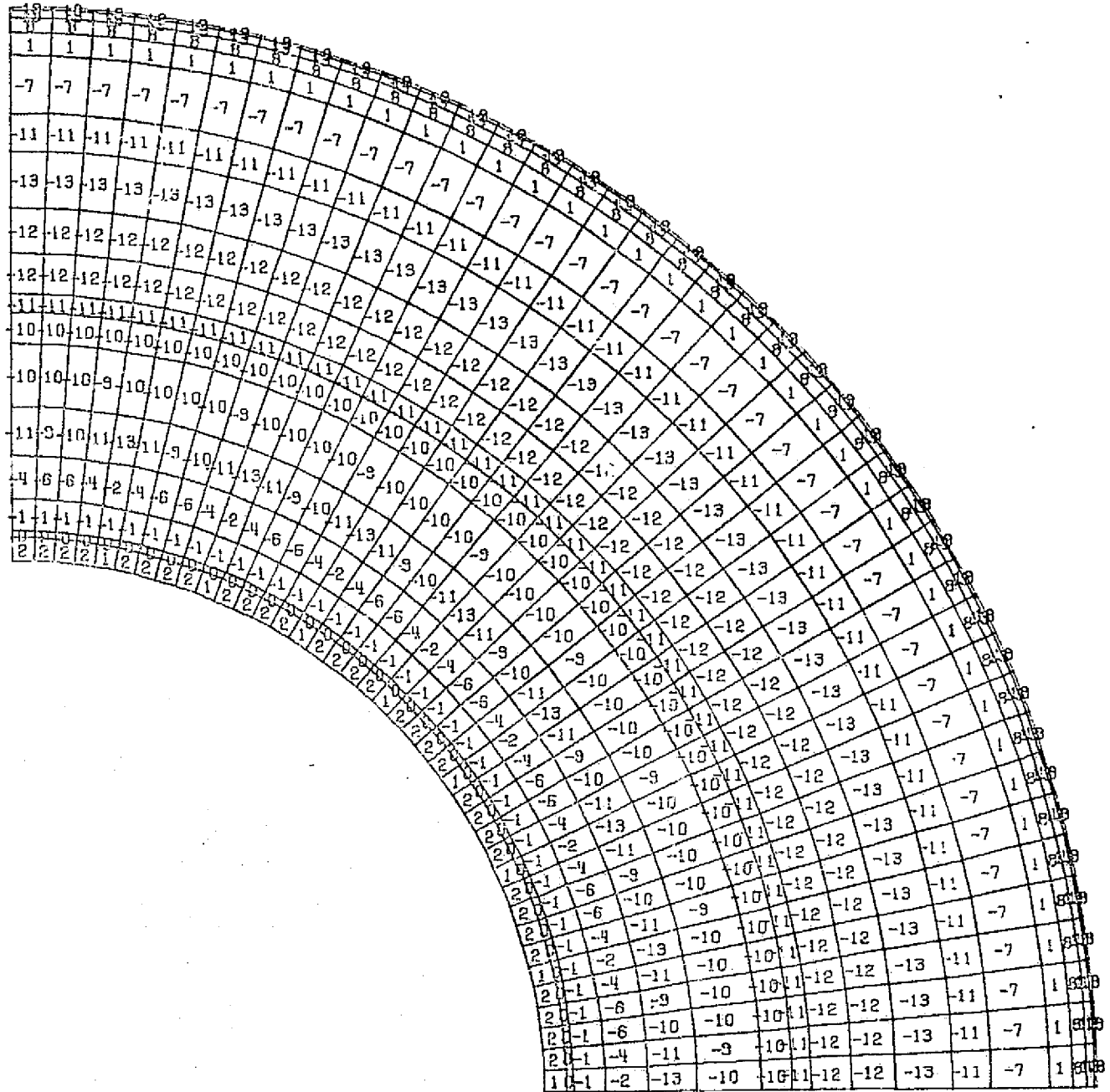

SPEC
3.1

NTF BULKHEAD
DOME

0 SCALE 26

FIG 126

DISPLAY= SX /1000 , NODE= 1 , SURFACE= 0

1/1/1

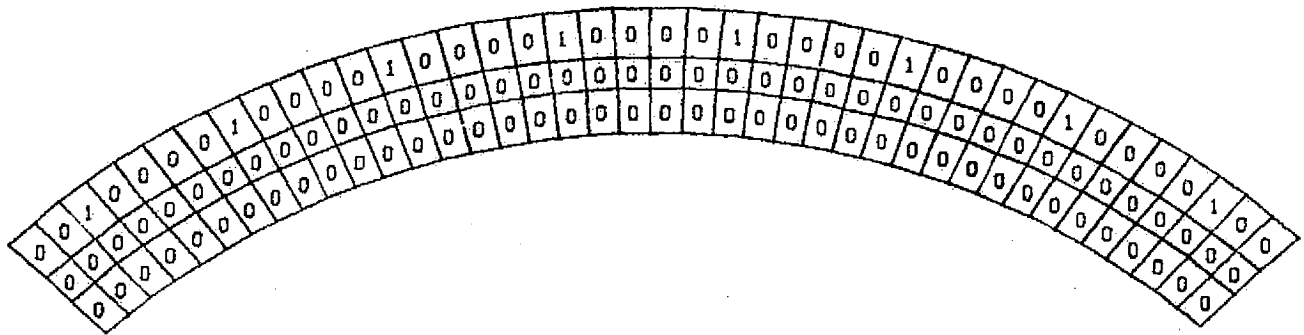

SPEC
2.1

NTF BULKHEAD
FLANGE SURFACE

0 _____ 21
SCALE

FIG 133

DISPLAY= SX /1000 , NODE= 1 , SURFACE= 1

1/1/1

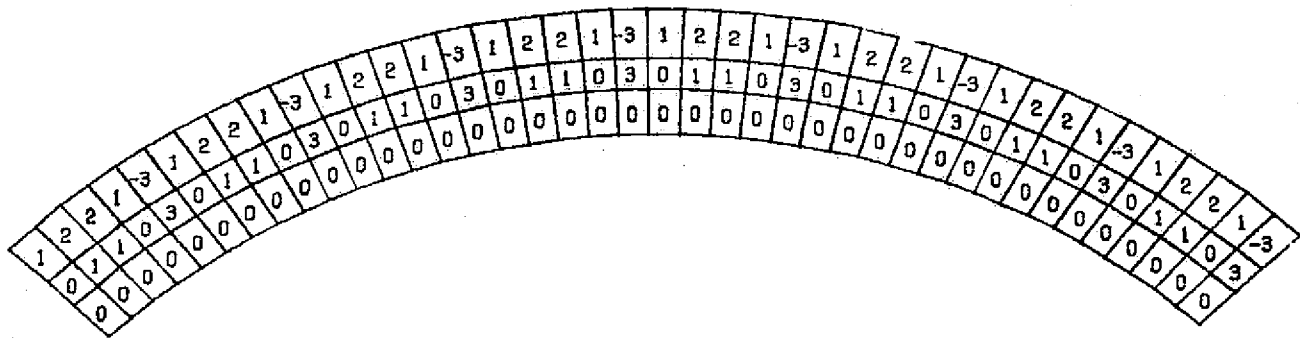

SPEC
2.1

NTF BULKHEAD
FLANGE SURFACE

0 ——— 21
SCALE

FIG 134

DISPLAY= SY /1000 , NODE= 1, SURFACE= 0

1/1/1

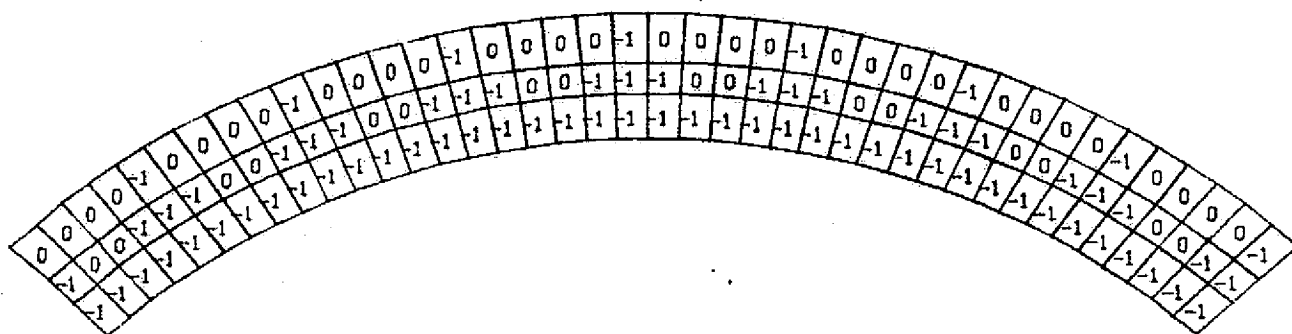

SPEC
2-1

NTF BULKHEAD
FLANGE SURFACE

0 21
SCALE

FIG 136

DISPLAY= SY /1000 , NODE= 1, SURFACE= 1

1/1/1

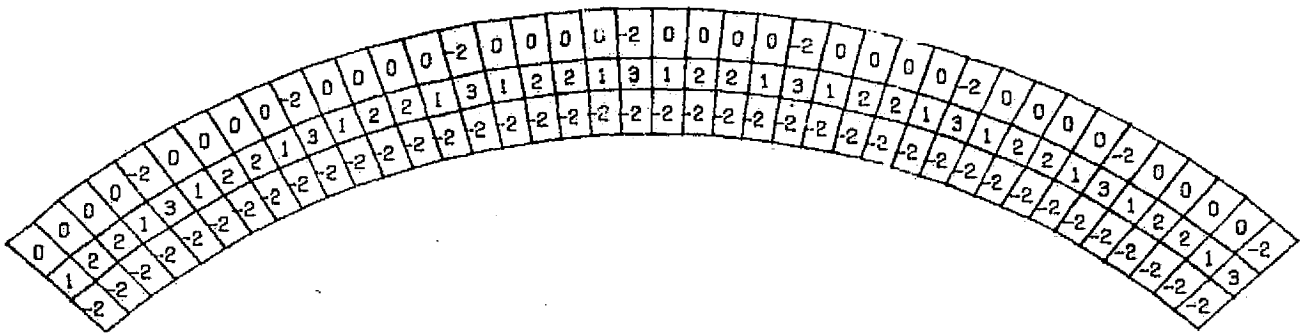

SPEC
2.1

NTF BULKHEAD
FLANGE SURFACE

0 SCALE 21

FIG 137

DISPLAY= SY /1000 , NODE= 1 , SURFACE= 2

1/1/1

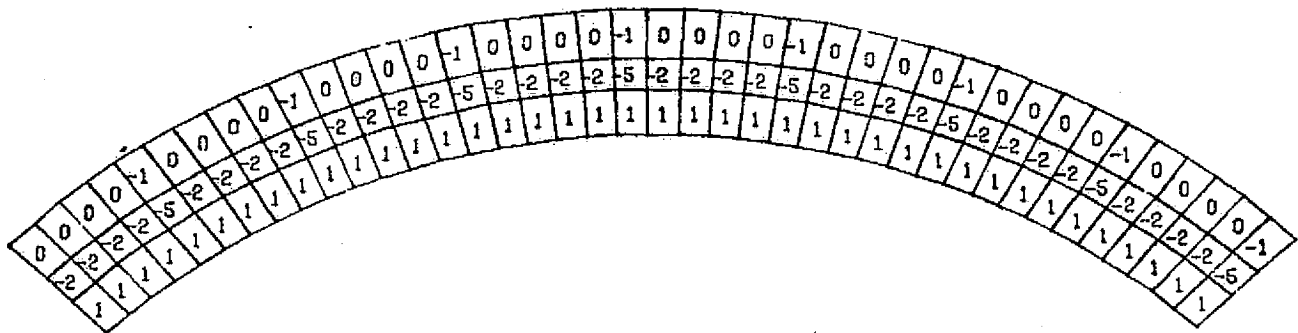

SPEC
2.1

NTF BULKHEAD
FLANGE SURFACE

0 SCALE 21

FIG 138

1/1/1

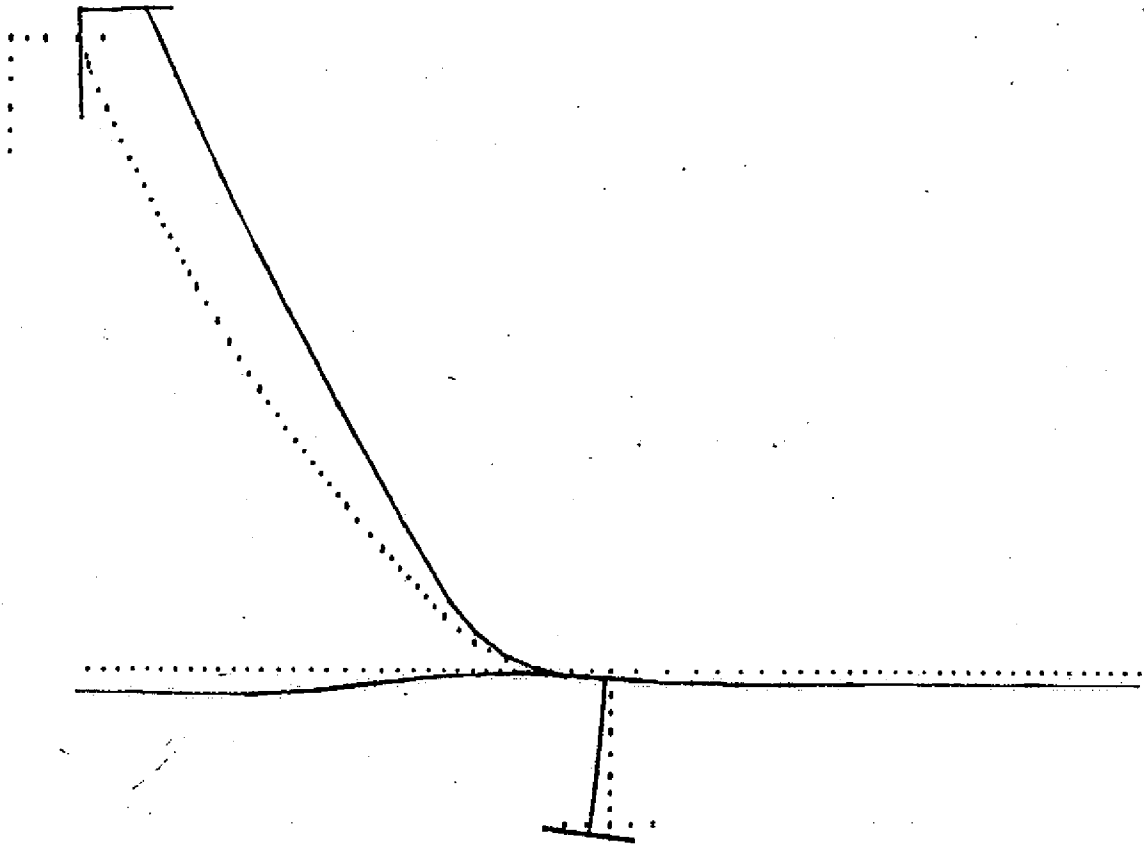

SPEC
12.1

NTF BULKHEAD
CROSS-SECTION VIEW

0 ——— 27
SCALE

ORIGINAL PAGE IS
OF POOR QUALITY

FIG 139

1/1/1

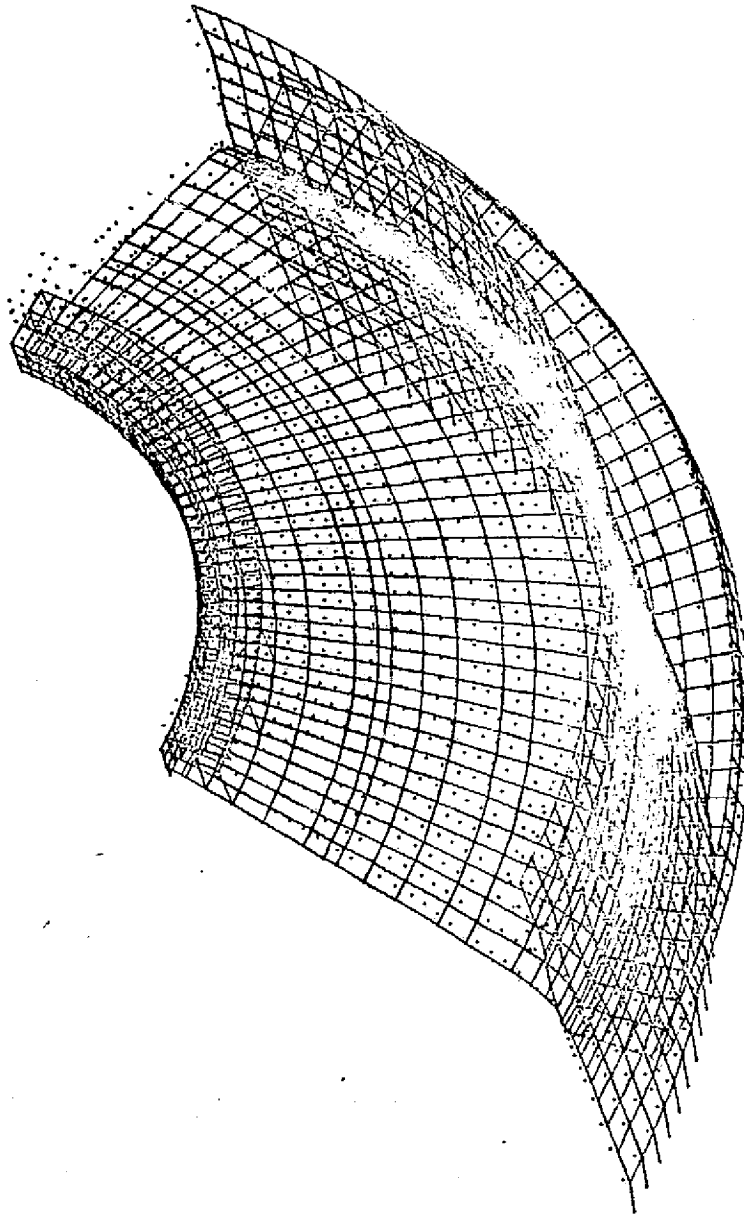

SPEC
1.1

NTF BULKHEAD

0 SCALE 44

FIG 140

CASE 5

GATE VALVE CLOSED

W/ TRANSIENT TEMPERATURE
PROFILE, FOR HEAT UP TIME
OF 30 MIN.

STRESS PLOTS

FIGURES 141 THRU 167

COMPUTER RUN NO. AAK

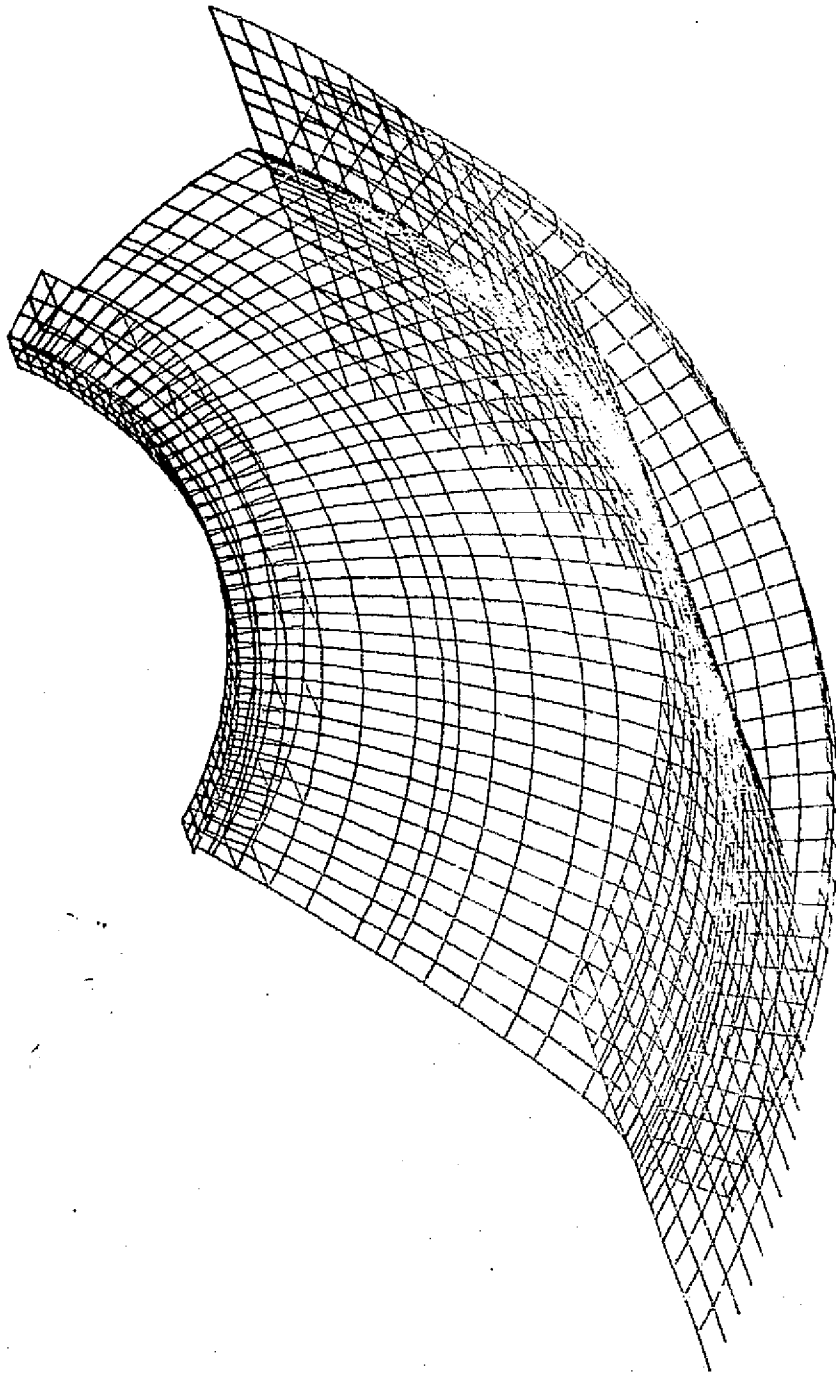

SPEC
1.1

NTF BULKHEAD
..VALVE OPEN AND TEMP DIST

0 ——— 41
SCALE

FIG. 141

DISPLAY= SX /1000 , NODE= 1 , SURFACE= 2

1/1/1

0	0	1	3	5	8	8	7	7	8	6	15	3	2	6	8	13	16
0	0	1	3	5	8	8	7	7	8	6	15	3	2	6	8	13	16
0	0	1	3	5	8	8	7	7	8	6	15	3	2	6	8	13	16
0	0	1	3	5	8	8	7	7	8	6	15	3	2	6	8	13	16
0	0	1	3	5	8	8	7	7	8	6	15	3	2	6	8	13	16
0	0	1	3	5	8	8	7	7	8	6	15	3	2	6	8	13	16
0	0	1	3	5	8	8	7	7	8	6	15	3	2	6	8	13	16
0	0	1	3	5	8	8	7	7	8	6	15	3	2	6	8	13	16
0	0	1	3	5	8	8	7	7	8	6	15	3	2	6	8	13	16
0	0	1	3	5	8	8	7	7	8	6	15	3	2	6	8	13	16
0	0	1	3	5	8	8	7	7	8	6	15	3	2	6	8	13	16
0	0	1	3	5	8	8	7	7	8	6	15	3	2	6	8	13	16
0	0	1	3	5	8	8	7	7	8	6	15	3	2	6	8	13	16
0	0	1	3	5	8	8	7	7	8	6	15	3	2	6	8	13	16
0	0	1	3	5	8	8	7	7	8	6	15	3	2	6	8	13	16
0	0	1	3	5	8	8	7	7	8	6	15	3	2	6	8	13	16
0	0	1	3	5	8	8	7	7	8	6	15	3	2	6	8	13	16
0	0	1	3	5	8	8	7	7	8	6	15	3	2	6	8	13	16
0	0	1	3	5	8	8	7	7	8	6	15	3	2	6	8	13	16
0	0	1	3	5	8	8	7	7	8	6	15	3	2	6	8	13	16
0	0	1	3	5	8	8	7	7	8	6	15	3	2	6	8	13	16
0	0	1	3	5	8	8	7	7	8	6	15	3	2	6	8	13	16
0	0	1	3	5	8	8	7	7	8	6	15	3	2	6	8	13	16
0	0	1	3	5	8	8	7	7	8	6	15	3	2	6	8	13	16
0	0	1	3	5	8	8	7	7	8	6	15	3	2	6	8	13	16
0	0	1	3	5	8	8	7	7	8	6	15	3	2	6	8	13	16
0	0	1	3	5	8	8	7	7	8	6	15	3	2	6	8	13	16
0	0	1	3	5	8	8	7	7	8	6	15	3	2	6	8	13	16
0	0	1	3	5	8	8	7	7	8	6	15	3	2	6	8	13	16
0	0	1	3	5	8	8	7	7	8	6	15	3	2	6	8	13	16
0	0	1	3	5	8	8	7	7	8	6	15	3	2	6	8	13	16
0	0	1	3	5	8	8	7	7	8	6	15	3	2	6	8	13	16
0	0	1	3	5	8	8	7	7	8	6	15	3	2	6	8	13	16
0	0	1	3	5	8	8	7	7	8	6	15	3	2	6	8	13	16
0	0	1	3	5	8	8	7	7	8	6	15	3	2	6	8	13	16
0	0	1	3	5	8	8	7	7	8	6	15	3	2	6	8	13	16
0	0	1	3	5	8	8	7	7	8	6	15	3	2	6	8	13	16
0	0	1	3	5	8	8	7	7	8	6	15	3	2	6	8	13	16
0	0	1	3	5	8	8	7	7	8	6	15	3	2	6	8	13	16
0	0	1	3	5	8	8	7	7	8	6	15	3	2	6	8	13	16

SPEC 5.1

NTF BULKHEAD SHELL

0 SCALE 36

FIG 144

1/1/1

DISPLAY= SX /1000 , NODE= 1 , SURFACE= 0

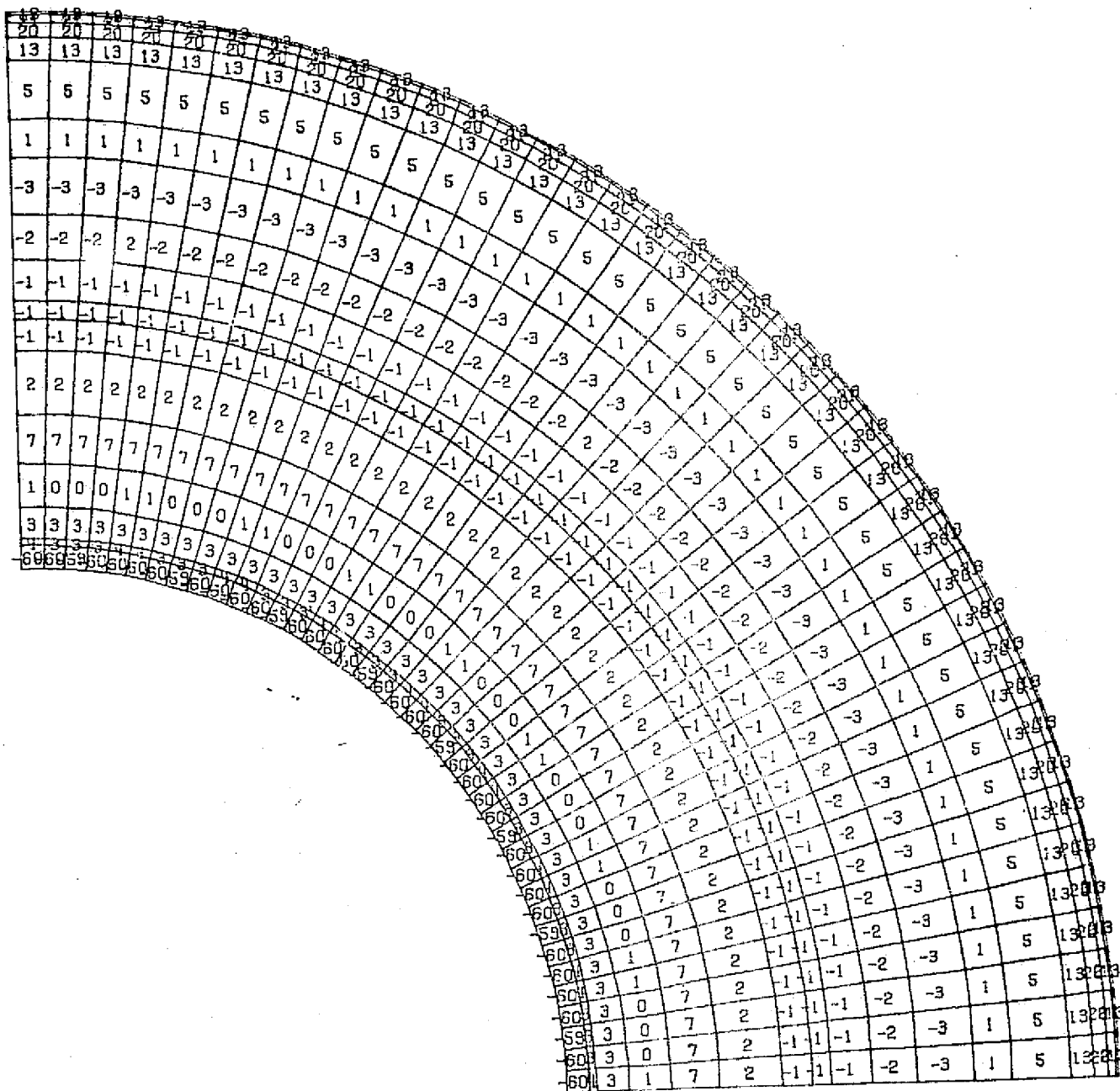

SPEC
3.1

NTF BULKHEAD
DOME

0 SCALE 26

FIG 148

DISPLAY= SX /1000 , NODE= 1 , SURFACE= 1

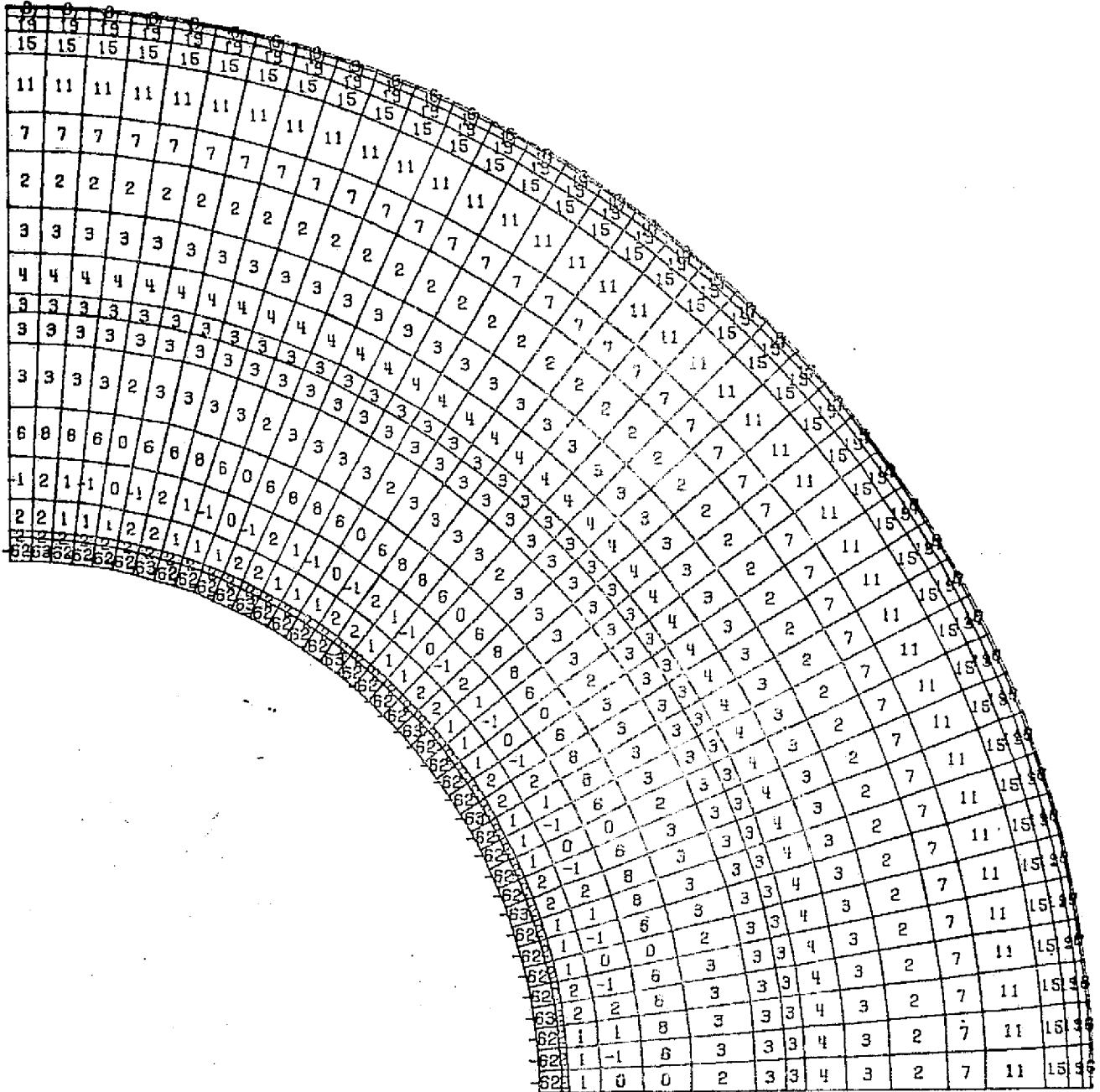

SPEC
3.1

NT_r BULKHEAD
DOME

0 26
SCALE

DISPLAY= SX /1000 , NODE= 1, SURFACE= 2

1/1/1

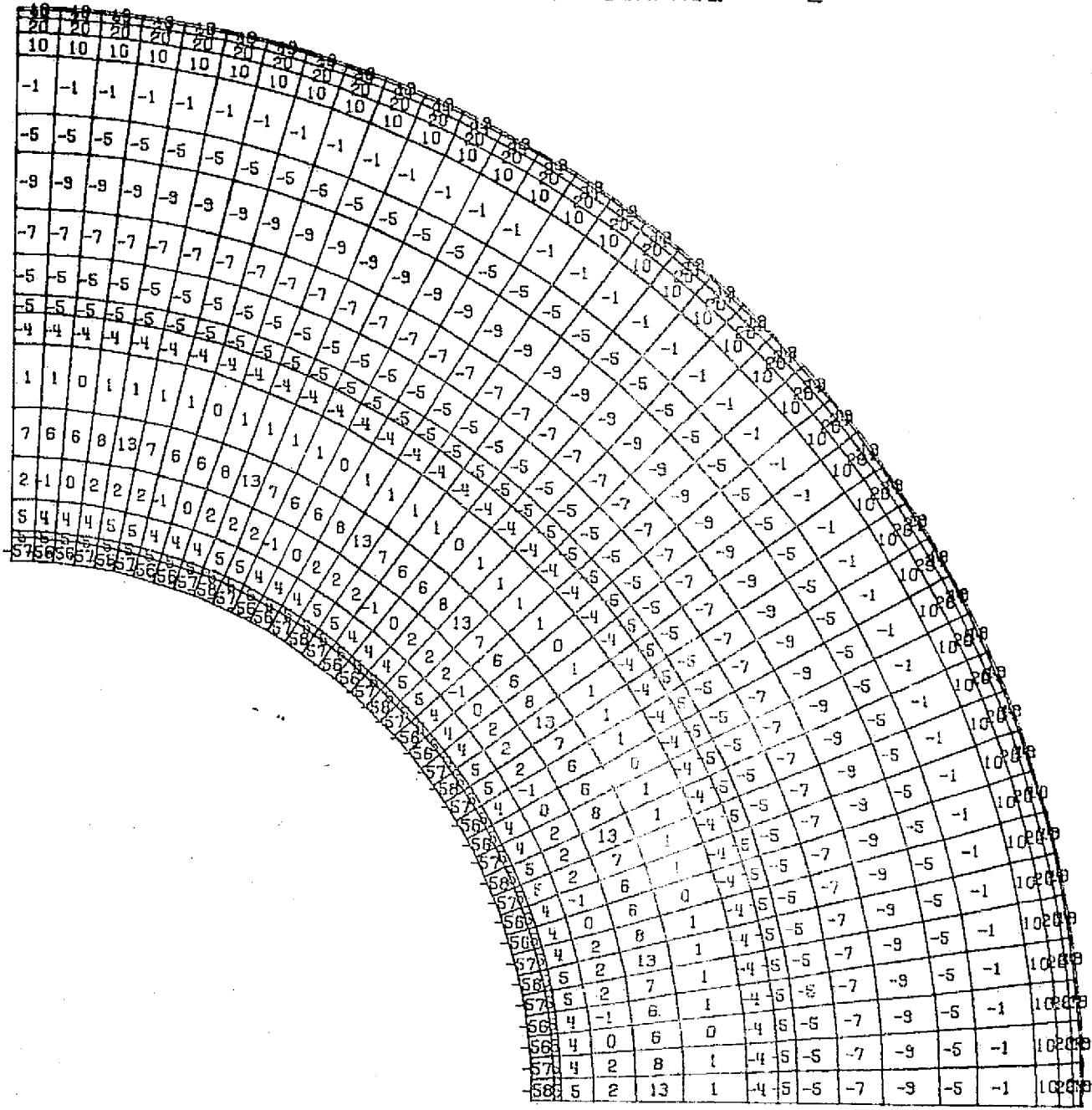

SPEC 3.1

NTF BULKHEAD DOME

0 SCALE 26

FIG 150

DISPLAY= SY /1000 , NODE= 1, SURFACE= 0

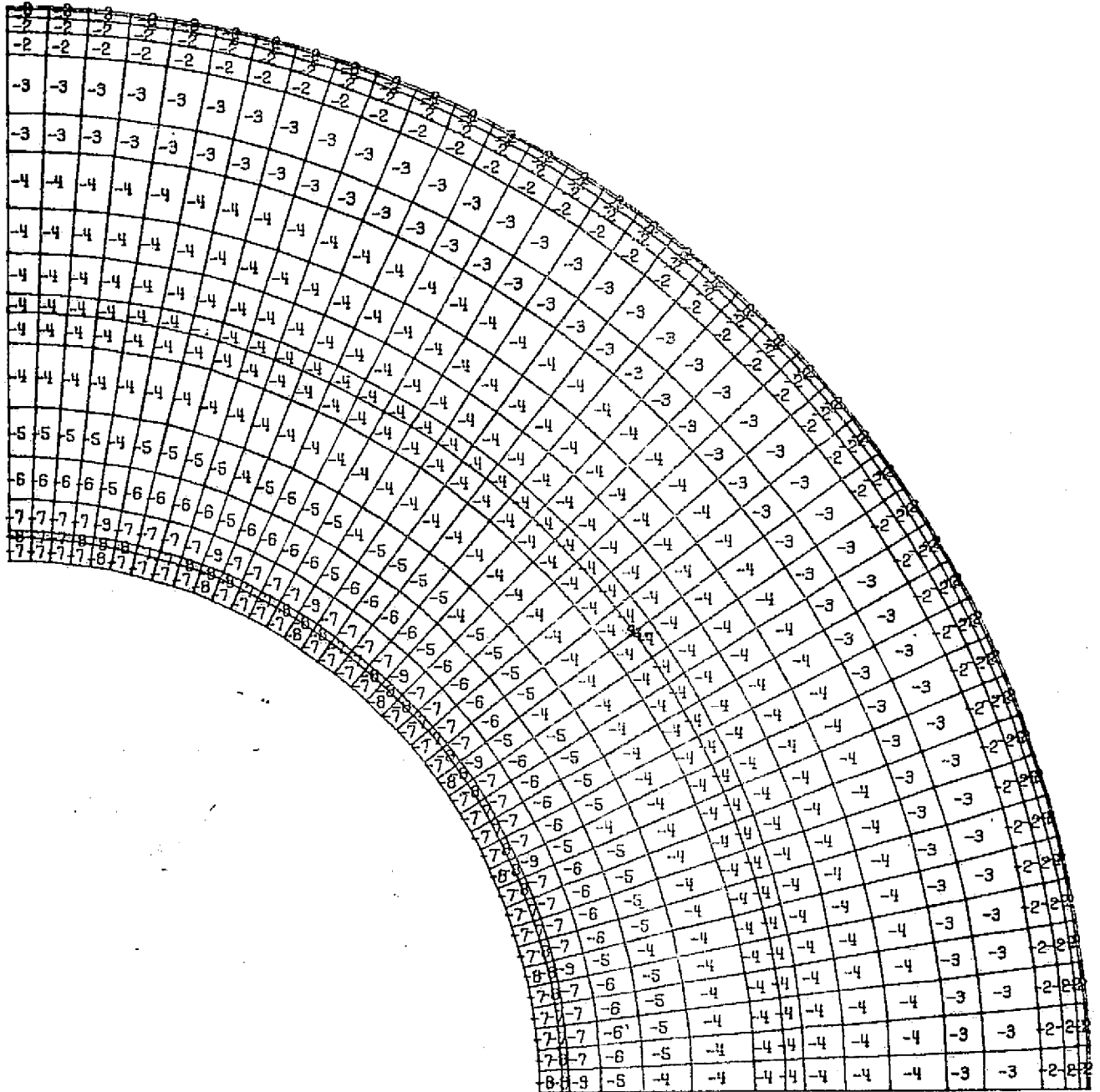

SPEC
3.1

NTF BULKHEAD
DOME

0 SCALE 26

DISPLAY= SY /1000 , NODE= 1, SURFACE= 1

1/1/1

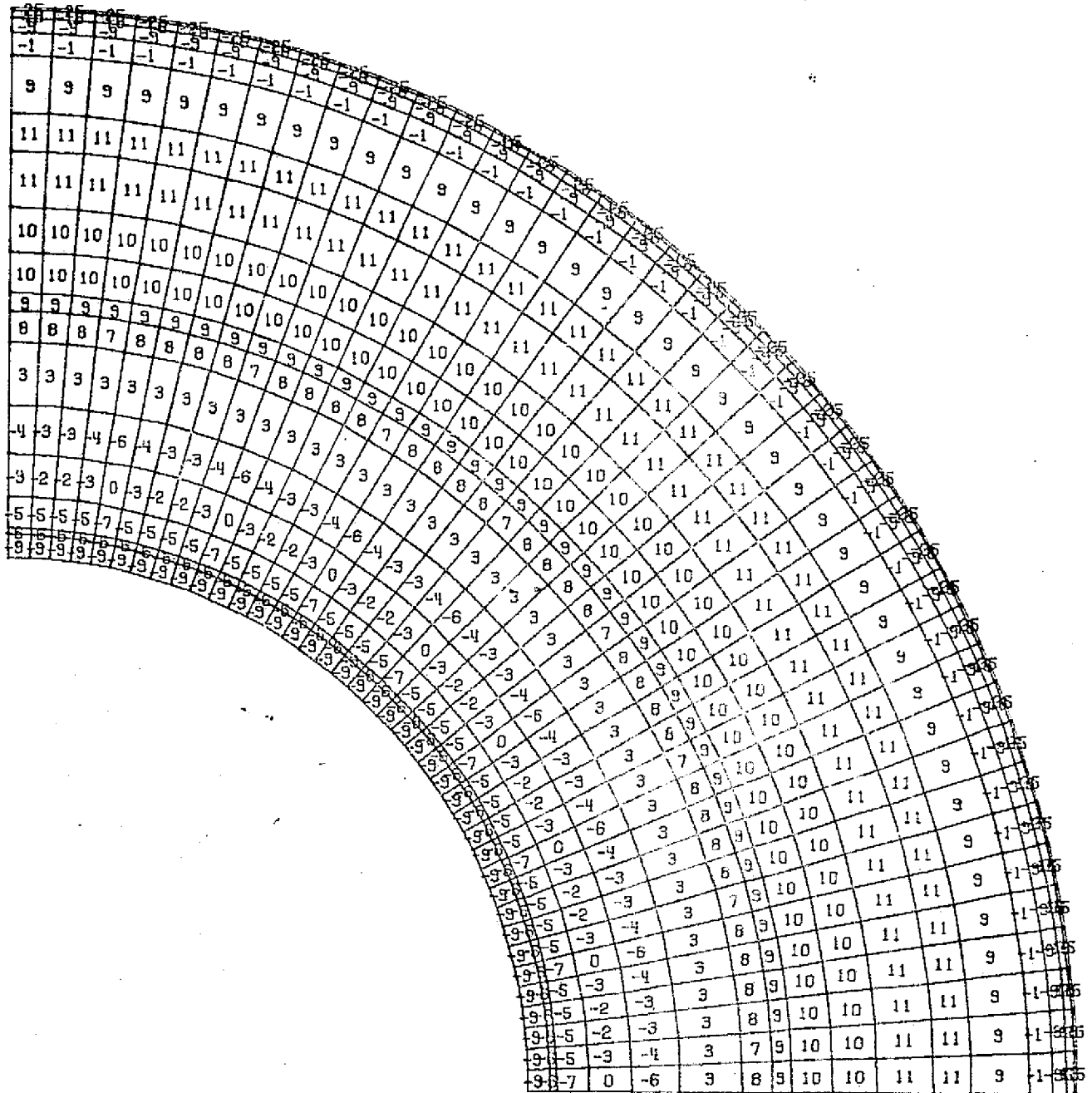

SPEC
3.1

NTF BULKHEAD
DOME

0 SCALE 26

FIG 152

1/1/1

DISPLAY= SY /1000 , NODE= 1 , SURFACE= 2

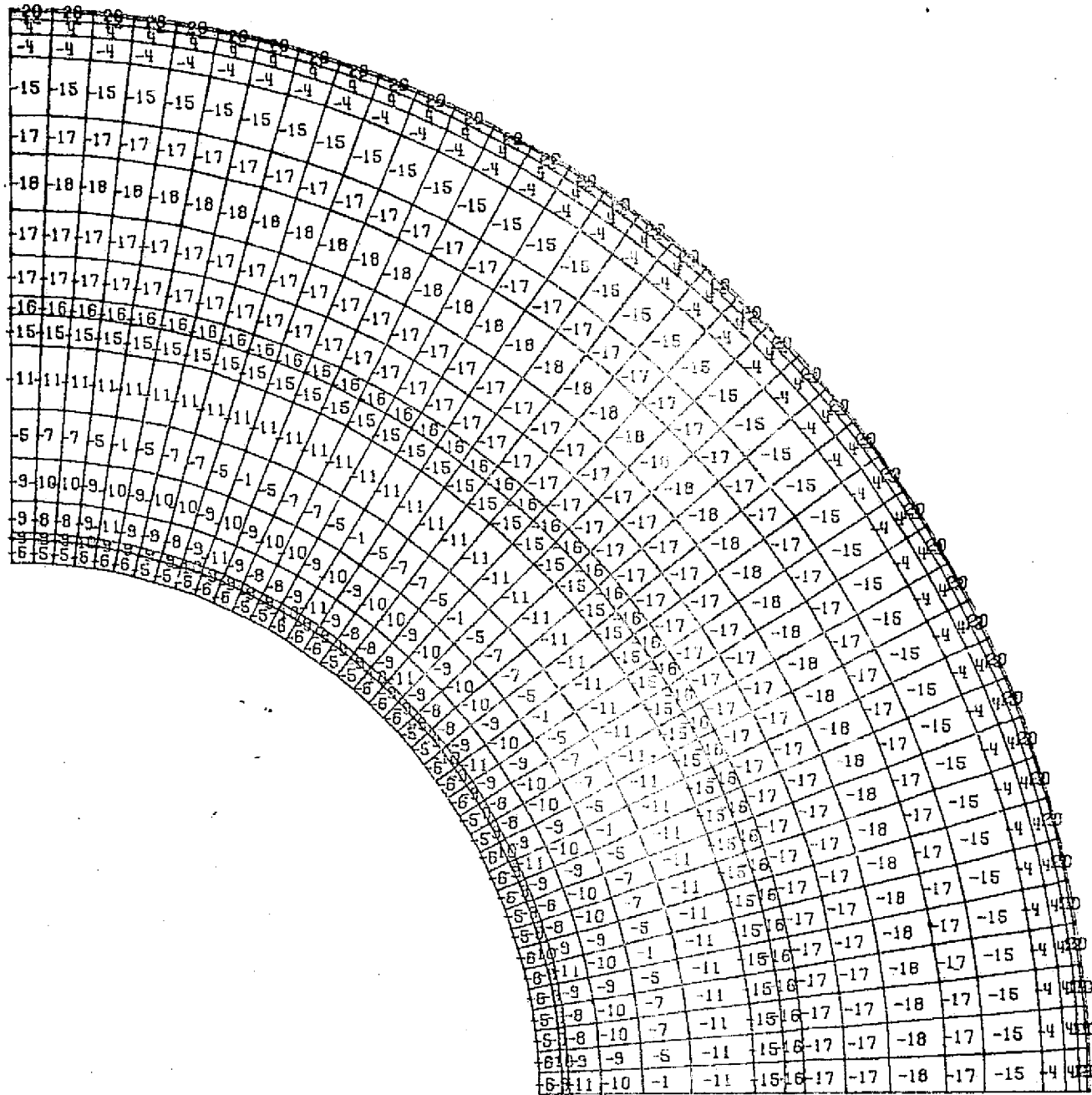

SPEC
3.1

NTF BULKHEAD
DOME

0 SCALE 26

ORIGINAL PAGE IS
OF POOR QUALITY

FIG 153

DISPLAY= SY /1000 , NODE= 1, SURFACE= 0

1/1/1

-3	-2	-2	-2	-3	-2	-2	-2	-2	-3	-2	-2	-2	-2	-3	-2	-2	-2	-2	-3	-2	-2	-2	-2	-3	-2	-2	-2	-2	-3	-2	-2	-2	-2	
-2	-2	-2	-2	-2	-2	-2	-2	-2	-2	-2	-2	-2	-2	-2	-2	-2	-2	-2	-2	-2	-2	-2	-2	-2	-2	-2	-2	-2	-2	-2	-2	-2	-2	
0	0	-1	-1	0	0	0	-1	-1	0	0	0	-1	-1	0	0	0	-1	-1	0	0	0	-1	-1	0	0	0	-1	-1	0	0	0	-1	-1	0

SPEC
10.1

NTF BULKHEAD
HATCH OPENING

0  18
SCALE

FIG 157

DISPLAY= SY /1000 , NODE= 1 , SURFACE= 1

1/1/1

9	9	8	8	8	9	9	8	8	8	9	9	8	8	8	9	9	8	8	8	9	9	8	8	8	9	9	8	8	8	9	9	8	8	8	9	9	8	8	8
-1	-1	-1	-1	-1	-1	-1	-1	-1	-1	-1	-1	-1	-1	-1	-1	-1	-1	-1	-1	-1	-1	-1	-1	-1	-1	-1	-1	-1	-1	-1	-1	-1	-1	-1	-1	-1	-1	-1	-1
5	5	4	5	6	5	5	4	5	6	5	5	4	5	6	7	5	4	5	6	5	5	4	5	6	5	5	4	5	6	5	5	4	5	6	5	5	4	5	6

SPEC
10.1

NTF BULKHEAD
HATCH OPENING

0 _____ 18
SCALE

FIG 158

DISPLAY= SY /1000 , NODE= 1, SURFACE= 2

1/1/1

14	13	13	13	14	13	13	13	13	14	13	13	13	13	14	13	13	13	13	14	13	13	13	13	14	13	13	13	13	14	13	13	13	13	14	13	13	13	13	14	13	13	13	13						
-4	-4	-4	-4	-4	-4	-4	-4	-4	-4	-4	-4	-4	-4	-4	-4	-4	-4	-4	-4	-4	-4	-4	-4	-4	-4	-4	-4	-4	-4	-4	-4	-4	-4	-4	-4	-4	-4	-4	-4	-4	-4	-4	-4	-4	-4	-4	-4	-4	-4
-5	-5	-7	-7	-5	-5	-7	-7	-5	-5	-5	-7	-7	-5	-5	-5	-7	-7	-5	-5	-5	-7	-7	-5	-5	-5	-7	-7	-5	-5	-5	-7	-7	-5	-5	-5	-7	-7	-5	-5	-5	-7	-7	-5	-5	-5	-7	-7	-5	

SPEC
10.1

NTF BULKHEAD
HATCH OPENING

0  18
SCALE

FIG 159

DISPLAY= SX /1000 , NODE= 1, SURFACE= 0

1/1/1

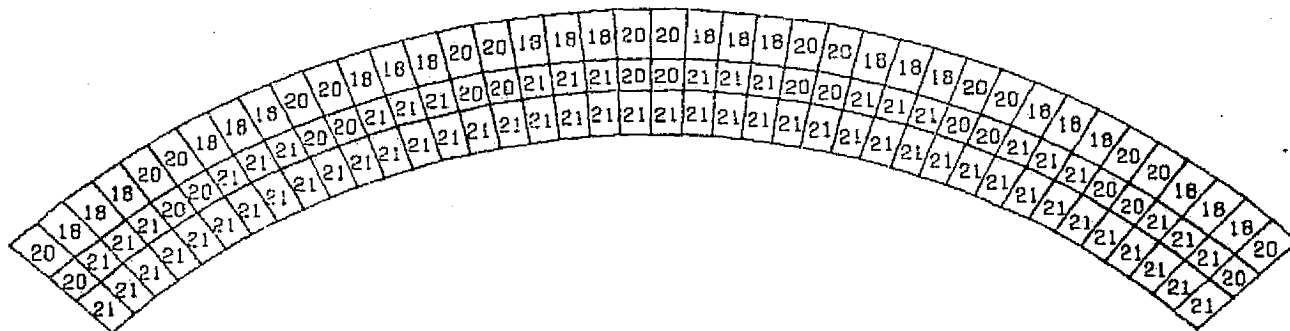

SPEC
2.1

NTF BULKHEAD
FLANGE SURFACE

0 SCALE 21

FIG 160

DISPLAY= SX /1000 , NODE= 1 , SURFACE= 1

1/1/1

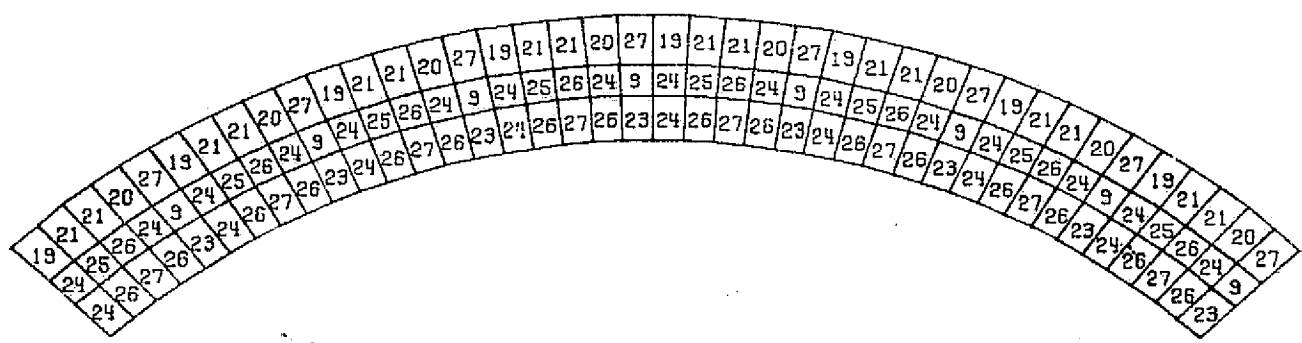

SPEC
2.1

NTF BULKHEAD
FLANGE SURFACE

0 ——— 21
SCALE

FIG 161

DISPLAY= SX /1000 , NODE= 1, SURFACE= 2

1/1/1

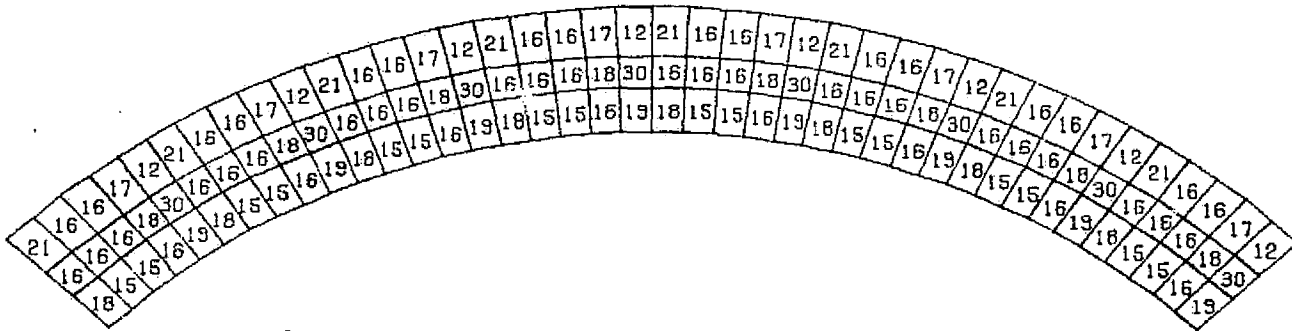

SPEC
2.1

NTF BULKHEAD
FLANGE SURFACE

0 ——— 21
SCALE

FIG 162

DISPLAY= SY /1000 , NODE= 1, SURFACE= 0

1/1/1

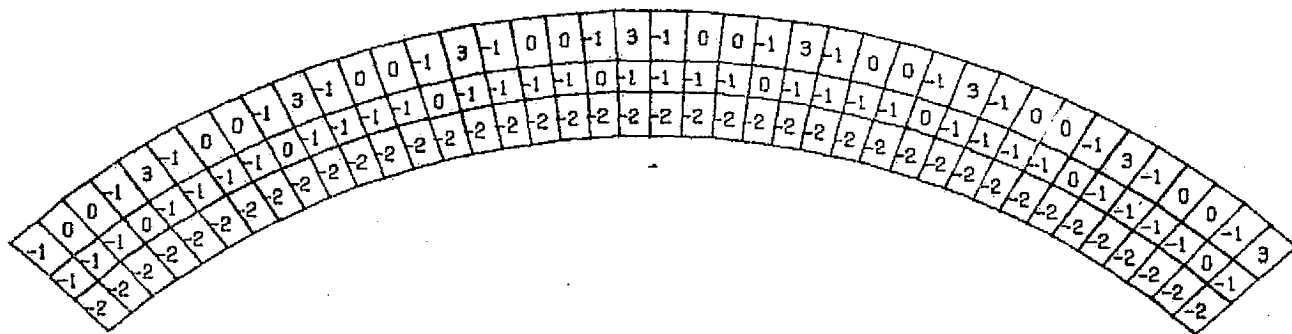

ORIGINAL PAGE IS
OF POOR QUALITY

SPEC
2.1

NTF BULKHEAD
FLANGE SURFACE

0 _____ 21
SCALE

FIG. 163

DISPLAY= SY /1000 , NODE= 1, SURFACE= 1

1/1/1

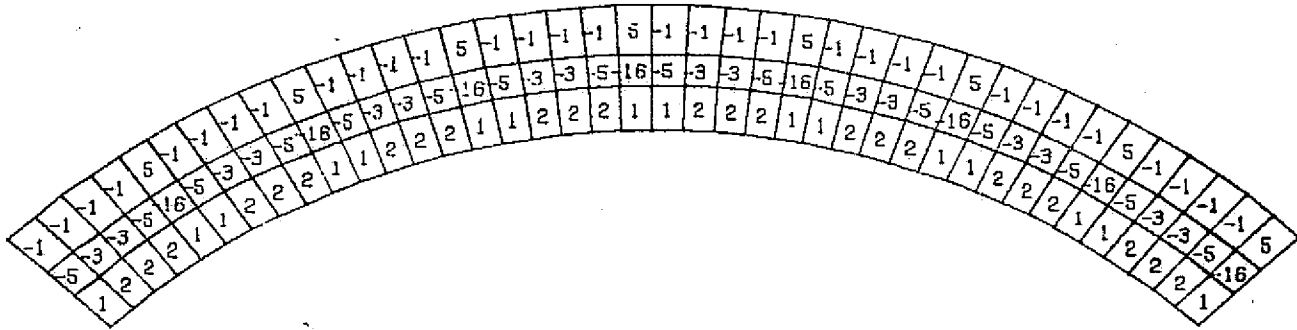

SPEC
2.1

NTF BULKHEAD
FLANGE SURFACE

0 ——— 21
SCALE

FIG 1.14

DISPLAY= SY /1000 . NODE= 1, SURFACE= 2

1/1/1

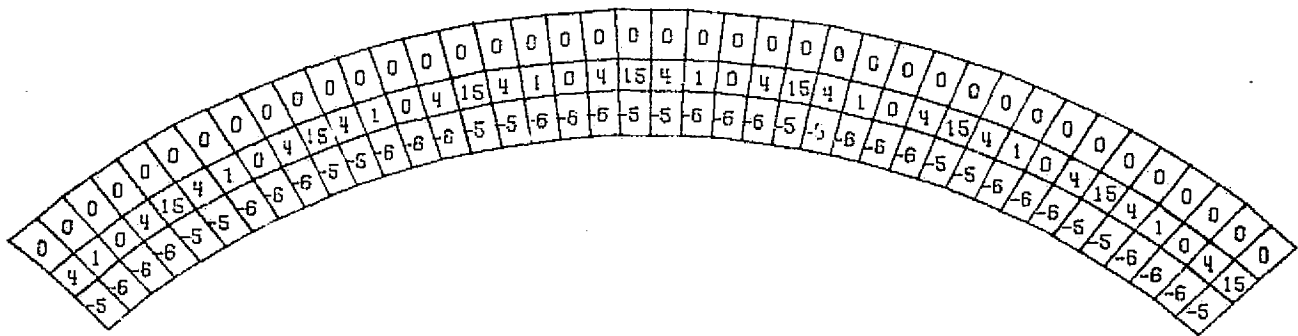

SPEC
2.1

NTF BULKHEAD
FLANGE SURFACE

0 ——— 21
SCALE

FIG 165

1/1/1

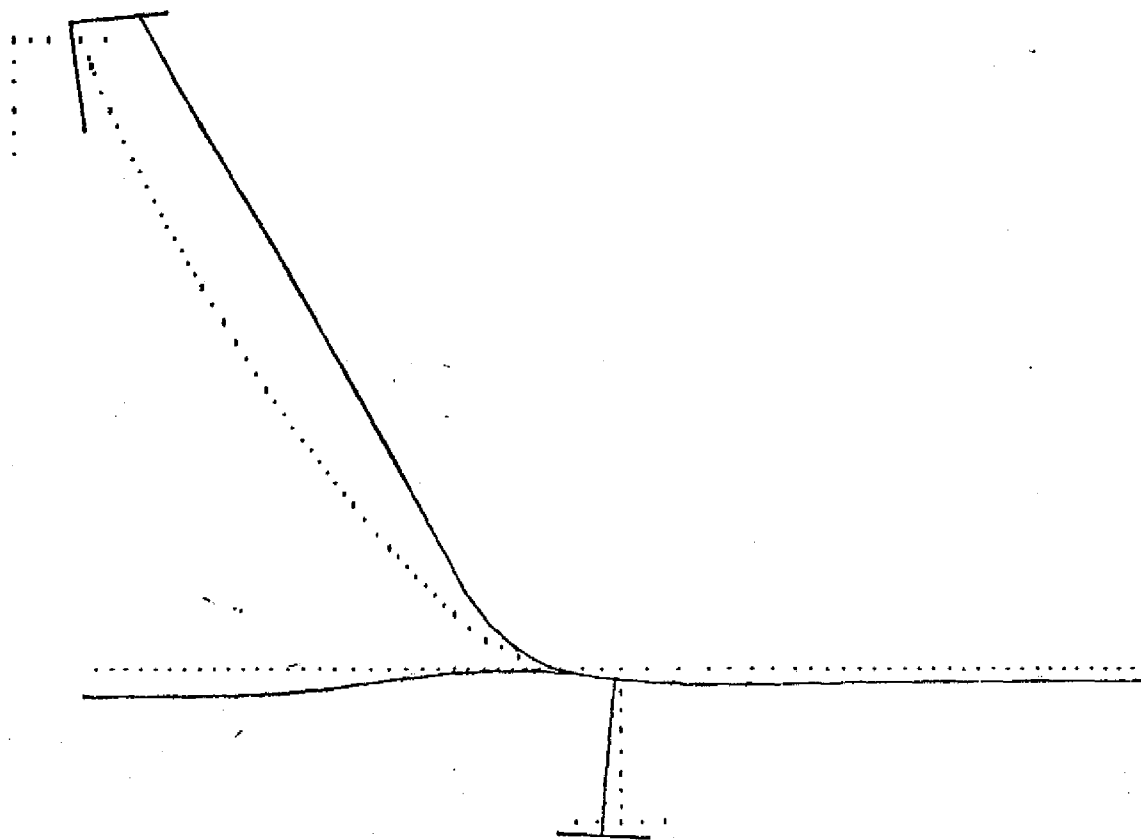

SPEC
12.1

NTF BULKHEAD
CROSS-SECTION VIEW

0 ——— 27
SCALE

ORIGINAL PAGE IS
OF POOR QUALITY

FIG 166

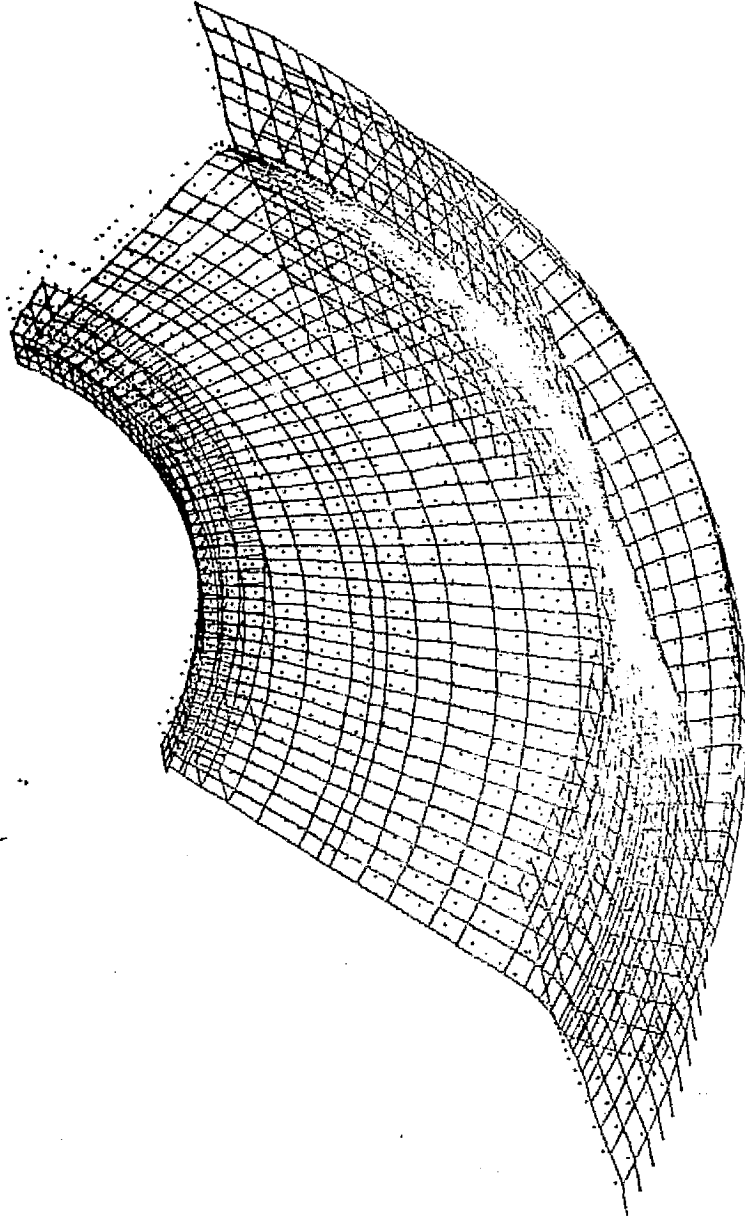

SPEC
1.1

NTF BULKHEAD
..VALVE OPEN AND TEMP DIST

0 SCALE 44

BY _____ DATE _____

SUBJECT _____

SHEET NO. 88 OF _____

CHKD. BY _____ DATE _____

JOB NO. _____

S4 & S5 Ring Analysis

Asymmetric Ring loads

MAT'L 304 ss

BY..... DATE.....
CHKD. BY..... DATE.....

SUBJECT.....

SHEET NO. 89 OF.....
JOB NO.

NTE S4 & S5 RING ANALYSIS
(304 S.S)

I	DESCRIPTION	90
II	Computer codes	91
III	Computer Model (OPERATING)	92
	A. GEOMETRY	93
	B. LOADS	98
VI	STRESS SUMMARY (OPERATING)	99
II	Computer model (HYDRO)	100
VI	HYDROSTATIC PRESSURE STRESSES	101
VII	STRESS SUMMARY (HYDRO)	102
VIII	STRESS EVALUATION	103

ORIGINAL PAGE IS
OF POOR QUALITY

PRECEDING PAGE BLANK NOT FILMED

BY _____ DATE _____ SUBJECT _____
CHKD. BY _____ DATE _____

SHEET NO. 90 OF _____
JOB NO. _____

DESCRIPTION

Stresses in subject Ring have been calculated based on external loads supplied by A/E. These stresses have been superimposed on pressure stresses from a finite element model. The resulting combined stresses for both hydro and normal operations are considered, and the stress evaluation follows. The ring as presently designed meets both the stress criteria and AISC code.

BY _____ DATE _____

SUBJECT _____

SHEET NO. 91 OF _____

CHKD. BY _____ DATE _____

JOB NO. _____

INRING

is a time-shared computer program which performs a structural analysis of circular rings subject to loading in the plane of the ring.

SPAR

is a finite element computer code used to calculate pressure stresses; from a full pressure cycle on a bulkhead computer model.

BY _____ DATE _____

SUBJECT _____

SHEET NO. 92 OF _____

CHKD. BY _____ DATE _____

JOB NO. _____

COMPUTER MODEL FOR OPERATING CASE

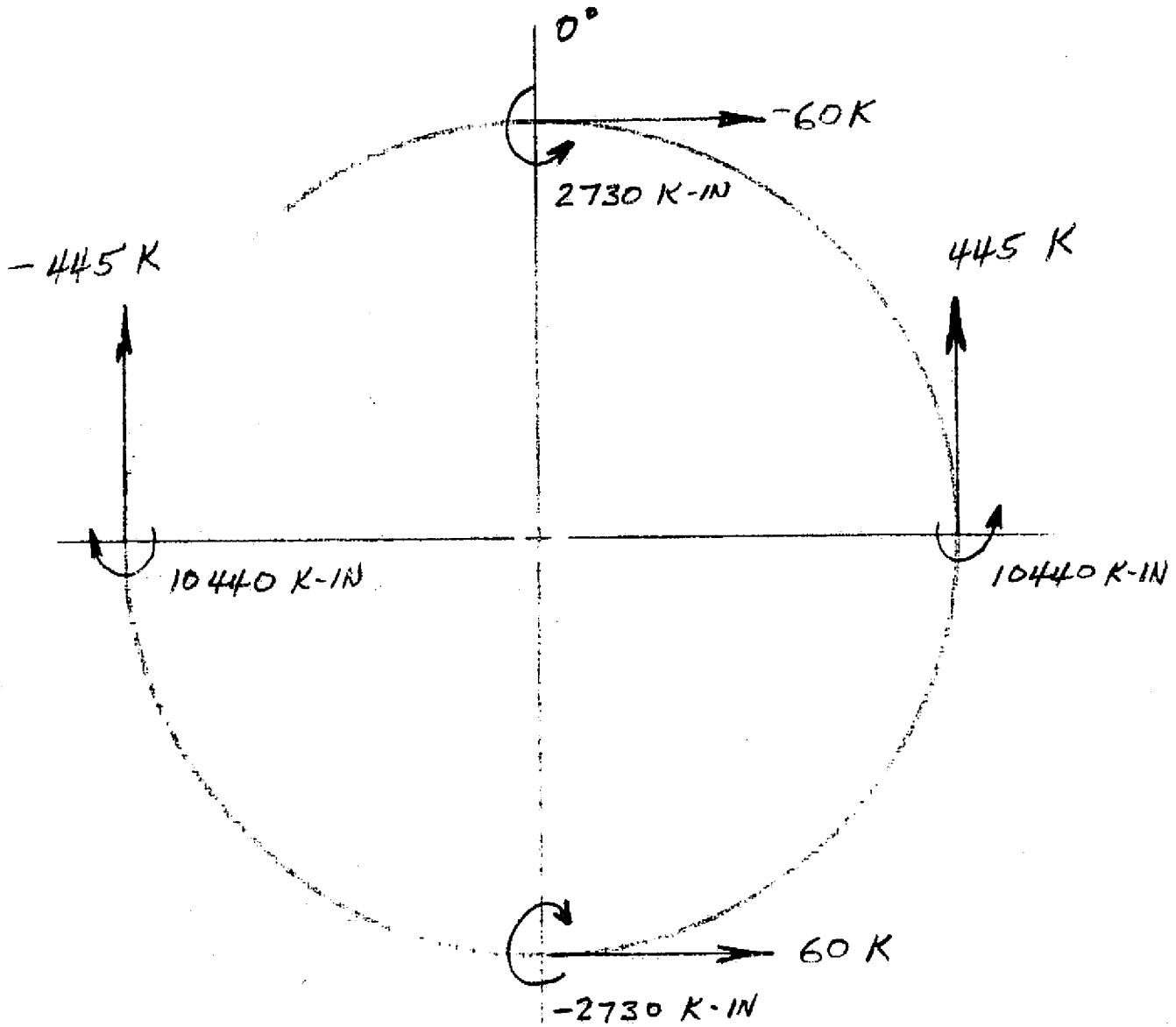

SIGN CONVENTION

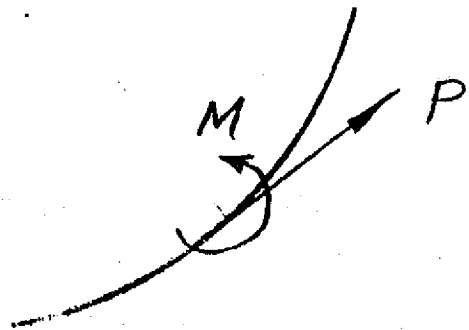

RING DESIGN FOR 304 S. STEEL

RING DETAILS

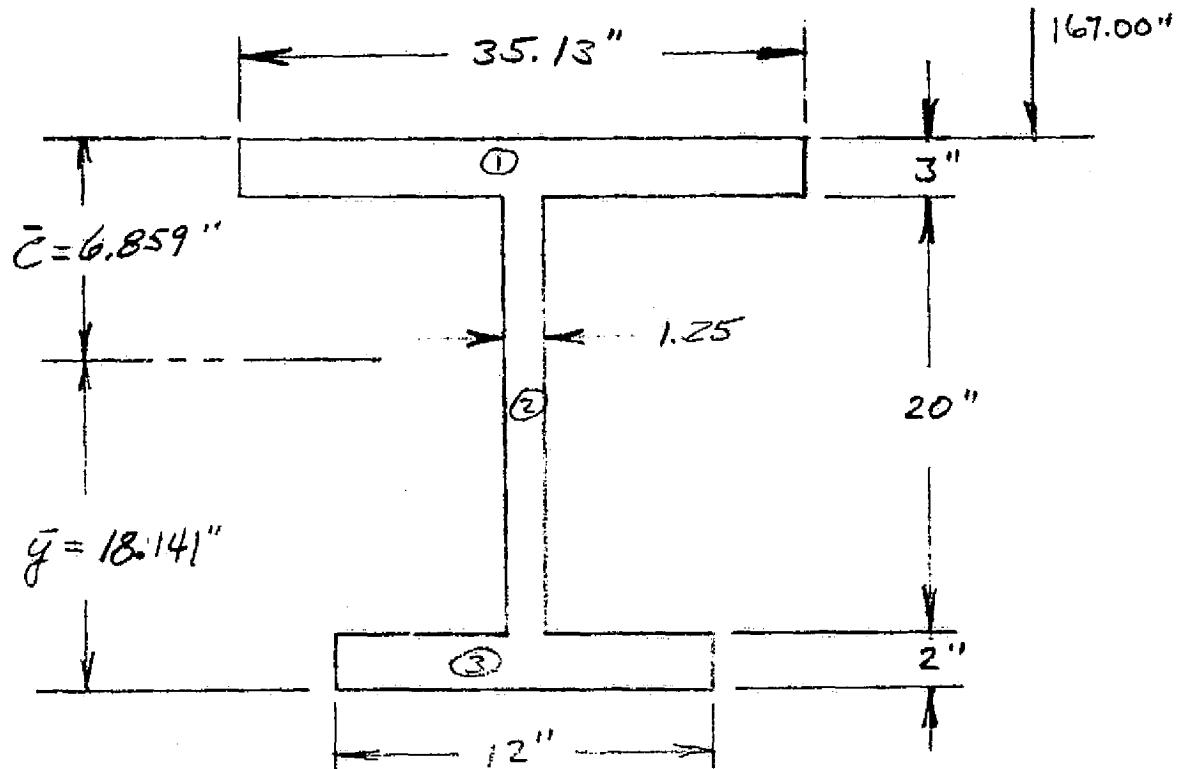

$D_o = 28'-4"$

$t = 3"$

$1.1 \sqrt{D_o t} = 1.1 [(340)(3")]^{\frac{1}{2}} = (31.94)(1.1) = 35.13"$

WEIGHT OF STEEL AT RING SUPPORT

735 K

WEIGHT OF WATER & STEEL = 1846 K

OTHER LOADS, SIMILAR TO ROOKER'S

CROSS SECTIONAL AREA

$$A = A_1 + A_2 + A_3$$

$$A = (35.13)(3) + (1.25)(20) + (12)(2)$$

$$A = 105.4 + 25 + 24$$

$$A = 154.4 \text{ IN}^2$$

CENT. LOCATION

$$\bar{y} = \frac{\sum Ay}{\sum A}$$

$$\bar{y} = \frac{[A_1 d_1 + A_2 d_2 + A_3 d_3]}{A_1 + A_2 + A_3}$$

$$\bar{y} = \frac{(105.4)(23.5) + (25)(12) + (24)(1)}{154.4}$$

$$\bar{y} = 18.141 \text{ ''}$$

$$\bar{c} = 25.00 - 18.141 \text{ ''}$$

$$\bar{c} = 6.859 \text{ IN.}$$

MOMENT OF INERTIA

$$\bar{I} = \sum (I_i + A_i d_i^2)$$

$$\bar{I} = \left(\frac{1}{12}\right)(35.13)(3)^3 + \left(\frac{1}{12}\right)(1.25)(20)^3 + \frac{1}{12}(12)(2)^3 \\ + (105.4)(5.359)^2 + (25)(6.141)^2 + (24)(17.141)^2$$

$$\bar{I} = 79.04 + 833.33 + 8 + 3026.97 \\ + 942.80 + 7051.53$$

$$\bar{I} = 11941.7 \text{ IN}^4$$

BENDING OF CURVED BEAMS

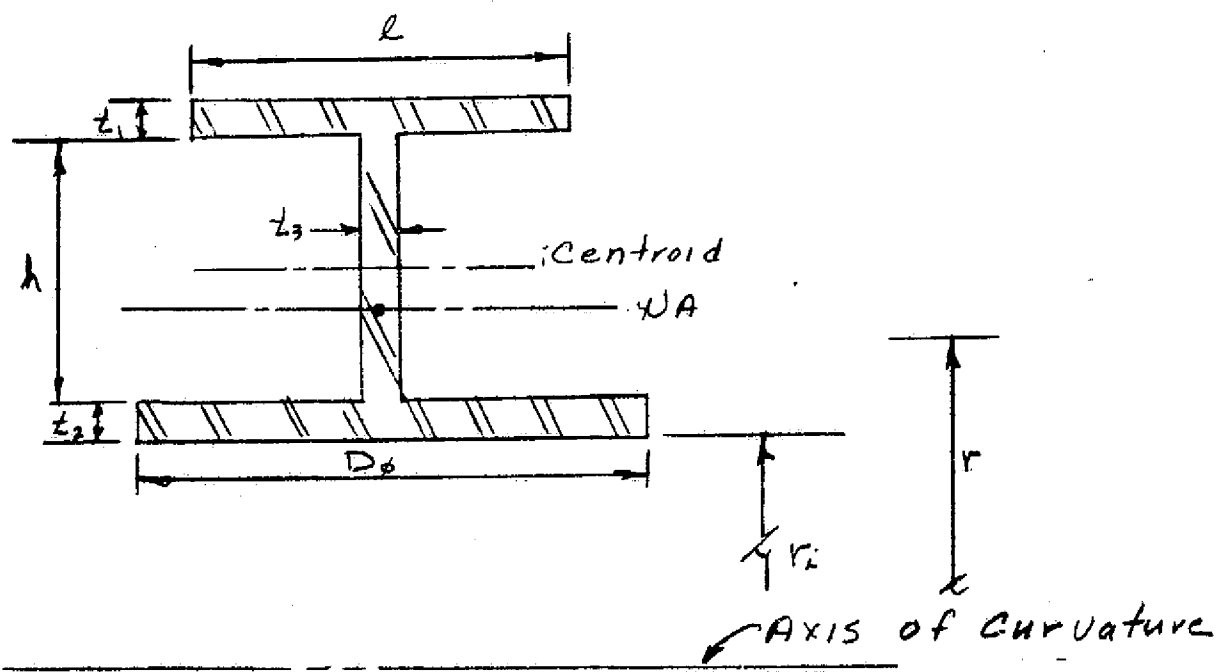

Bending stress for Curve beams

Bending Stresses for a curved beam is given by:

$$\sigma_s = \frac{M (R - r)}{r A (R - \bar{r})}$$

M = moment

r = stress point

\bar{r} = centroid

$$R = \frac{A}{\int_A \frac{dA}{r}}$$

A = AREA

R, for a "Tee"

$$R = \frac{t_1 l + h t_3 + D_0 t_2}{\int_{r_1}^{r_1+t_2} \frac{D_0 dr}{r} + \int_{r_1+t_2}^{r_1+t_2+h} \frac{t_3 dr}{r} + \int_{r_1+t_2+h}^{r_1+t_2+h+t_1} \frac{l dr}{r}} =$$

$$R = \frac{t_1 l + h t_3 + D_0 t_2}{D_0 \ln\left(\frac{r_1+t_2}{r_1}\right) + t_3 \ln\left(\frac{r_1+t_2+h}{r_1+t_2}\right) + l \ln\left(\frac{r_1+t_2+h+t_1}{r_1+t_2+h}\right)}$$

GEOMETRICAL + MATERIAL PROPERTIES

$D_0 = 35.13''$	$I = 11941.7 \text{ IN}^4$
$t_1 = 2.00''$	$E = 20 \times 10^6 \text{ PSI}$
$t_2 = 3.00''$	$\rho = .283 \text{ \#/IN}^3$
$t_3 = 1.25''$	$A = 154.4 \text{ IN}^2$
$l = 12.00''$	
$r_i = 167.00''$	
$\bar{r} = 173.86''$	
$h = 20.00''$	

NEUTRAL AXIS LOCATION

$$E = \frac{2 \times 12 + 20 \times 1.25 + 35.13 \times 3.00}{35.13 \ln\left(\frac{167+300}{167}\right) + 1.25 \ln\left(\frac{167+3+20}{167+3}\right) + 12 \ln\left(\frac{167+3+20+2}{167+3+20}\right)}$$

$E = 173.451''$	Neutral Axis
-----------------	--------------

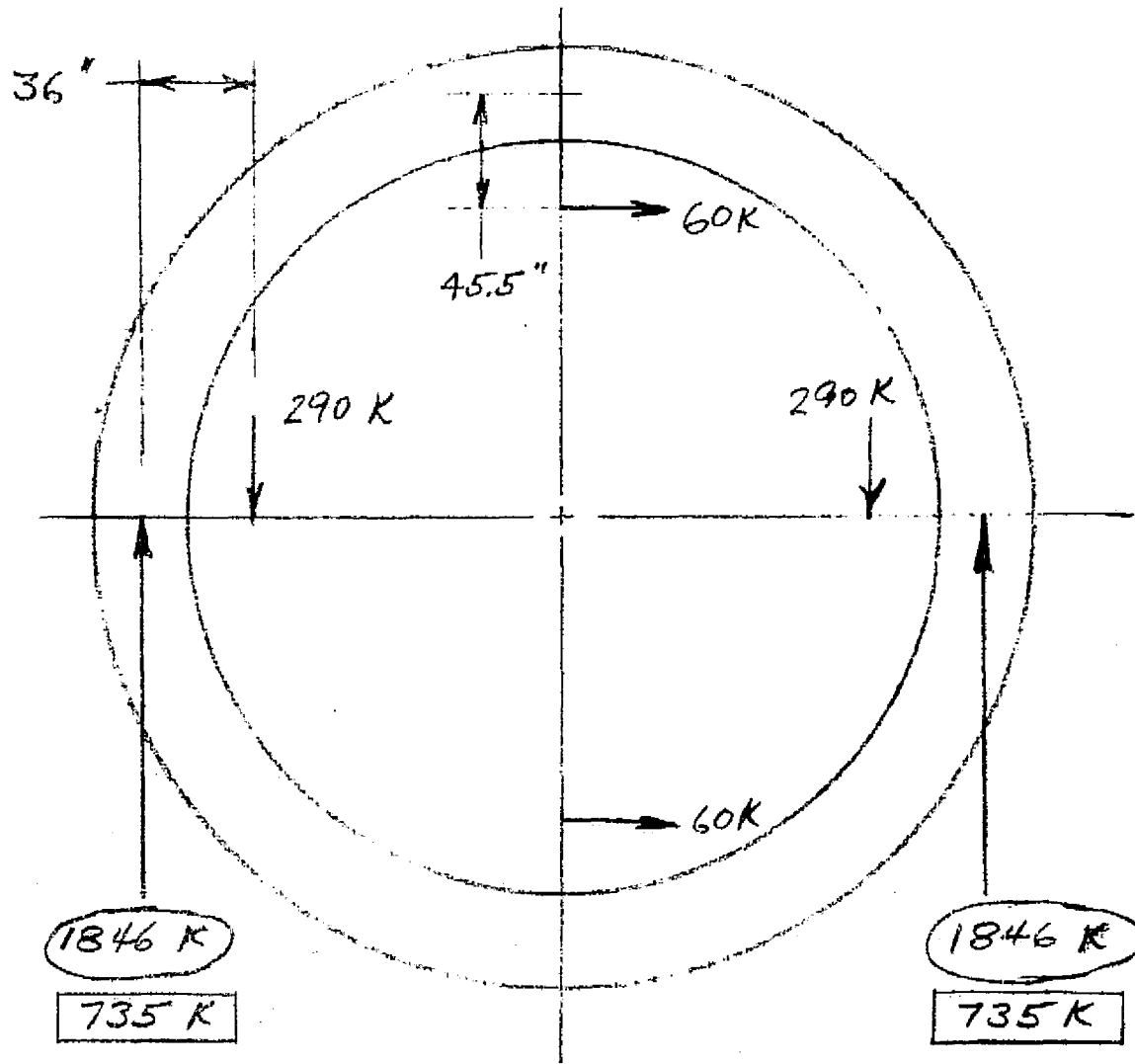
LOAD CONDITIONSWEIGHT OF 304 S. STEEL

$$W_s = 735 - 290 = \boxed{445 \text{ K}}$$

WEIGHT OF WATER DURING HYDRO.

$$W_w = 1846 - 735 = \boxed{1111 \text{ K}}$$

STRESS Summary (OPERATING)

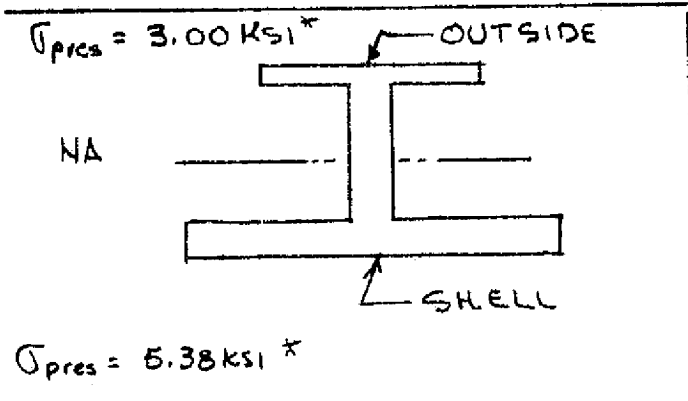

* from Spar computer analysis

OUTSIDE (KSI)					Shell (KSI)			
Location	Axial	Bending	Comb	Comb w/press.	Bending	Combined	Combined w/press	Peak
0	4.05	-2.57	-2.16	0.84	1.02	1.43	6.81	
0	.02	1.61	1.63	4.63	-.64	-.63	4.75	
30	-.10	1.64	1.53	4.53	-.65	-.76	4.62	
60	.65	.07	-.58	2.42	-.03	-.68	4.7	
90	-1.3	-8.91	-10.23	-7.23	3.56	2.25	7.63	
90	1.57	7.06	8.62	11.62	-2.82	-1.25	4.13	
120	.80	.60	1.40	4.40	-.24	.56	5.94	
150	.0	.75	.75	3.76	-.3	-.3	5.09	
180	-.40	2.57	2.16	5.16	-1.03	-1.43	3.95	
180	-.02	-1.61	-1.63	1.37	.64	.627	6.01	
210	.11	-1.64	-1.53	1.47	.66	.76	6.14	
240	.65	-.07	.58	3.58	.03	.68	6.57	
270	1.31	8.9	10.23	13.23	-3.57	-2.25	3.13	13.23
270	-1.57	-7.06	-8.62	-5.62	2.82	1.25	6.63	
300	-.804	.60	-.21	2.79	-.24	-1.04	4.33	
330	-.009	-75.0	-84.03	2.916	.030	.021	5.40	
360	-.404	-2.57	-2.16	.84	1.03	1.43	6.81	

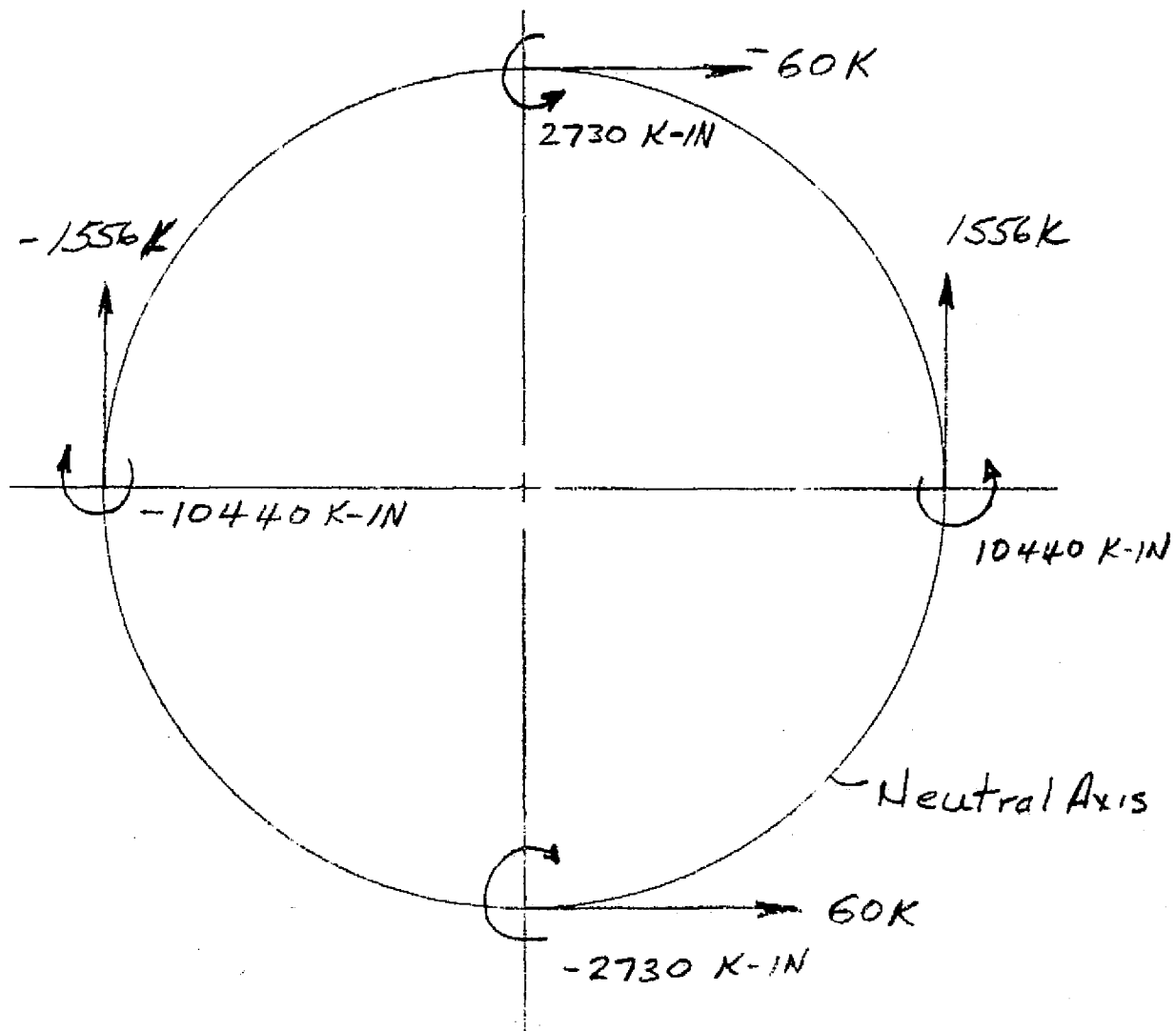
COMPUTER MODEL FOR HYDROSTATIC CASEGEOMETRICAL + MATERIAL PROPERTIES

$$R = 173.95 IN \quad \text{to NA}$$

$$A = 154.4 IN^2$$

$$C = 18.55 IN$$

$$I = 11941.7 IN^4$$

$$E = 28 \times 10^6 \text{ PSI}$$

$$\rho = .283 \text{ #/IN}^3$$

HYDROSTATIC PRESSURE STRESS

OPERATING PRESSURE STRESSES :

5.38 KSI - on shell

3.00 KSI outside fiber

$$P_H = 1.5 \times 119 + \frac{62.4}{144} \left(\frac{41}{2} + \frac{28}{2} \right) = 193.45 \text{ PSI}$$

$$\text{Stress scale factor} = \frac{193.45}{119} = 1.626$$

$$1.626 \times 5.38 = 8.75 \text{ KSI, on shell}$$

$$1.626 \times 3.00 = 4.88 \text{ KSI, outside fiber}$$

STRESS Summary (Hydro)

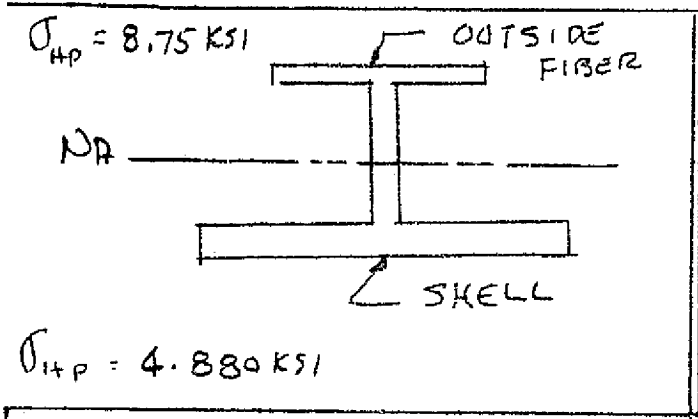

ORIGINAL PAGE IS
OF POOR QUALITY

Location	OUTSIDE FIBER (KSI)				SHELL (KSI)		
	AXIAL	BENDING	Combined	Combined w/Pressure	Bending	Combined	Combined w/pressure
0	1.670	-18.000	-16.352	-11.422	7.206	8.876	17.626
0	1.281	-13.845	-12.564	-7.684	5.536	6.536	15.567
30	1.290	-13.995	-12.706	-7.826	5.596	6.885	15.635
60	0.451	5.985	6.436	11.316	-2.393	-1.942	6.808
90	-1.986	13.363	11.377	16.257	-5.343	-7.336	1.426
90	-4.788	-1.928	-6.716	-1.836	0.771	-4.017	4.733
120	5.290	-1.929	3.360	8.240	0.771	6.061	14.811
150	2.356	-14.531	-12.174	-7.294	5.810	8.166	16.916
180	-.425	-.511	-.936	3.944	.204	-.220	8.530
180	-1.670	10.213	8.544	13.424	-4.084	-5.753	2.997
210	-1.281	6.037	4.756	9.636	-2.414	-3.695	5.055
240	-0.451	2.179	1.727	6.607	-.871	-1.322	7.428
270	4.788	-10.091	14.879	19.759	-4.035	0.753	9.503
270	5.290	-.5.879	-11.169	-6.289	2.351	-2.939	5.811
300	-2.688	6.722	4.366	9.246	-2.688	-5.044	3.706
330	0.425	-7.297	-6.873	-1.993	2.918	3.343	12.093
360	1.670	-18.000	-16.352	-11.472	7.206	8.876	17.626

STRESS Evaluation

Hydrostatic Test condition design Consideration.

$$\text{at } \theta = 0^\circ$$

$$S_1 = 5.38 \text{ KSI} \quad (\text{INSIDE FIBER})$$

$$S_2 = 8.876$$

$$S_1 + S_2 = 14.256 \text{ KSI} \leq .8 \sigma_{yd}(\text{weld}) = 24 \text{ OK}$$

$$S_{2f} = 19.759 \text{ KSI} \quad (\text{OUTSIDE FIBER})$$

$$S_{2f} \leq .9 \sigma_{yf}(\text{weld}) = 27 \text{ KSI}$$

$$19.759 < 27.0 \text{ KSI} \quad \text{OK.}$$

This support Ring (S4 AND/OR S5)
meet the STRESS Evaluation Hydrostatic
TEST criteria.

ASME Code

$$F_B \leq \frac{2}{3} F_y = \frac{2}{3} (30) = 20 \text{ KSI}$$

$$\text{at } \theta = 270^\circ \quad F_B = 19.759 \quad (\text{OUTSIDE FIBER})$$

$$19.759 < 20 \text{ KSI} \quad \text{OK}$$

SMD