

NASA CR-

151003

CONTROL MECHANISMS OF CIRCADIAN RHYTHMS IN BODY COMPOSITION:

IMPLICATIONS FOR MANNED SPACEFLIGHT

(NASA-CR-151003) CONTROL MECHANISMS OF
CIRCADIAN RHYTHMS IN BODY COMPOSITION:
IMPLICATIONS FOR MANNED SPACEFLIGHT Final
Report (Harvard Medical School, Boston,
Mass.) 136 p HC \$6.00

N76-33838

Unclas
07261

CSCI 06P G3/52

Final Report on Year 2 Contract NAS9-14249 of
the National Aeronautics and Space Administration
(Lyndon B. Johnson Space Center, Houston, Texas)

Held at the Department of Surgery
Harvard Medical School at the Peter Bent Brigham Hospital
Boston, Massachusetts

September 1, 1975 - September 30, 1976

Prepared by Martin C. Moore-Ede, M.D., Ph.D. (Principal Investigator)
Assistant Professor of Physiology, Harvard Medical School and Consultant
in Surgery (Physiology) at the Peter Bent Brigham Hospital.



CONTENTS

- I Introduction
- II Background
- III Experimental Studies
 - A) Experimental System
 - B) First Year of Research Contract (Summary)
 - C) Second Year Research Programs
- IV List of Publications
- V Equipment Purchased with Contract
- VI Monthly Reports
- VII Copies of Publications

I. Introduction

This is the final report on year 2 of NASA contract NAS9-14249 which was held by the Department of Surgery of Harvard Medical School at the Peter Bent Brigham Hospital, Boston, Massachusetts 02115 from September 1, 1975 - September 30, 1976.

The research conducted under this contract investigated the mechanisms that underlie the internal synchronization of the circadian (approximately 24 hour) variations in electrolyte content in body compartments and examined the significance of these circadian oscillations for manned spaceflight. The research program utilized an unanesthetized, chair-acclimatized monkey preparation which the principal investigator developed in the laboratories of the Department of Physiology, Harvard Medical School.

II. Background

Circadian rhythms in biological variables are one outward manifestation of an important evolutionary adaptation to life on a rotating planet: the ability to measure time. This capability enables organisms to predict the major changes in environmental conditions and the consequent alterations in food supply and predator activity which occur with a 24-hour periodicity because of the earth's rotation. Thus, for example, adaptive physiological and behavioral responses which may take several hours to be activated can be initiated in advance of the predicted environmental challenge, or events where timing may be critical for survival, such as emergence in flies, can be timed to occur at the point of maximum environmental advantage.

There is now considerable evidence to indicate that such circadian time measurement is the product of an oscillating system within the organism. The responses of this oscillating system to manipulations in environmental time

cues are now well established, but current knowledge of the anatomical and physiological organization of the circadian timing systems within advanced multicellular organisms such as mammals is still very limited.

As man ventures out into space, it has become particularly important to investigate the control of the circadian oscillating system because of its important adaptive functions under earthbound conditions which no longer apply in space. The circadian oscillations in physiological functions are normally synchronized to a strict 24-hour period when man is on the surface of the earth. In space however the oscillating components of the earth's environment which contribute to the normal external and internal synchronization of the circadian system are no longer present, unless artificially supplied. It therefore becomes important to examine the effect of their absence, and to investigate the necessity for supplying circadian oscillations in the spacecraft environment to achieve optimal physiological functioning.

A system that is particularly important to study in this regard comprises the circadian oscillations in the body compartmental distribution of electrolytes and fluids. Fluid and electrolyte balance is subjected to major perturbations in space, and additional imbalances due to circadian internal desynchronization could have potentially dangerous consequences. The research performed under this contract investigated the internal synchronization of circadian rhythms in the squirrel monkey and examined the implications of this internal synchronization for the control of fluid and electrolyte shifts. Particular attention was devoted to the causes and effects of internal desynchronization, a state where different circadian rhythms within the same animal free-run with different periods, indicating that separate oscillating components of the circadian timing system have lost temporal coordination with each other.

III. Experimental Studies

The experimental work performed under the second year of this contract used primarily the chair-acclimatized squirrel monkey system. As a background a brief review of a) the experimental methodology and b) the work using this monkey preparation during the first year of this contract are discussed.

A) Experimental system (Figure 1)

The experimental work utilized a chair-acclimatized squirrel monkey system developed in this laboratory. This system, which is particularly suited for later Spacelab studies, is described in detail in the attached publications emanating from this program. In brief, the animals sat in the chair, restrained only around the waist. The animals were trained to operate a lever to gain food pellets, which were continuously available. The timing of each food pellet gained was recorded on a continuous paper record and the data manually digitized to obtain an hourly rate. Urine collections were continuously collected from a padded funnel snugly enclosing penis and scrotum. This arrangement assured the collection of urine samples uncontaminated by food debris or feces. The urine passed through a tube from the funnel to a fraction collector which collected the urine in two hourly aliquots. The fraction collector could be accessed without disturbing the monkey for the daily removal of the urines.

Environmental illumination, temperature and auditory and social stimuli were controlled by conducting experiments within an isolation chamber. Within this chamber, temperature was maintained at $25 \pm 1^\circ\text{C}$, external auditory stimuli were muffled by noise sources (91 dB, RE: $20 \mu\text{N}/\text{m}^2$) within the chamber and illuminations was provided at 600 lux from 08:00 hr - 20:00 hr EDT and <1 lux from 20:00 hr - 08:00 hr (LD 12:12) daily. Experiment apparatus was controlled by an automatic programmable switchboard which provided timing, counting and recording functions.

Figure 1.

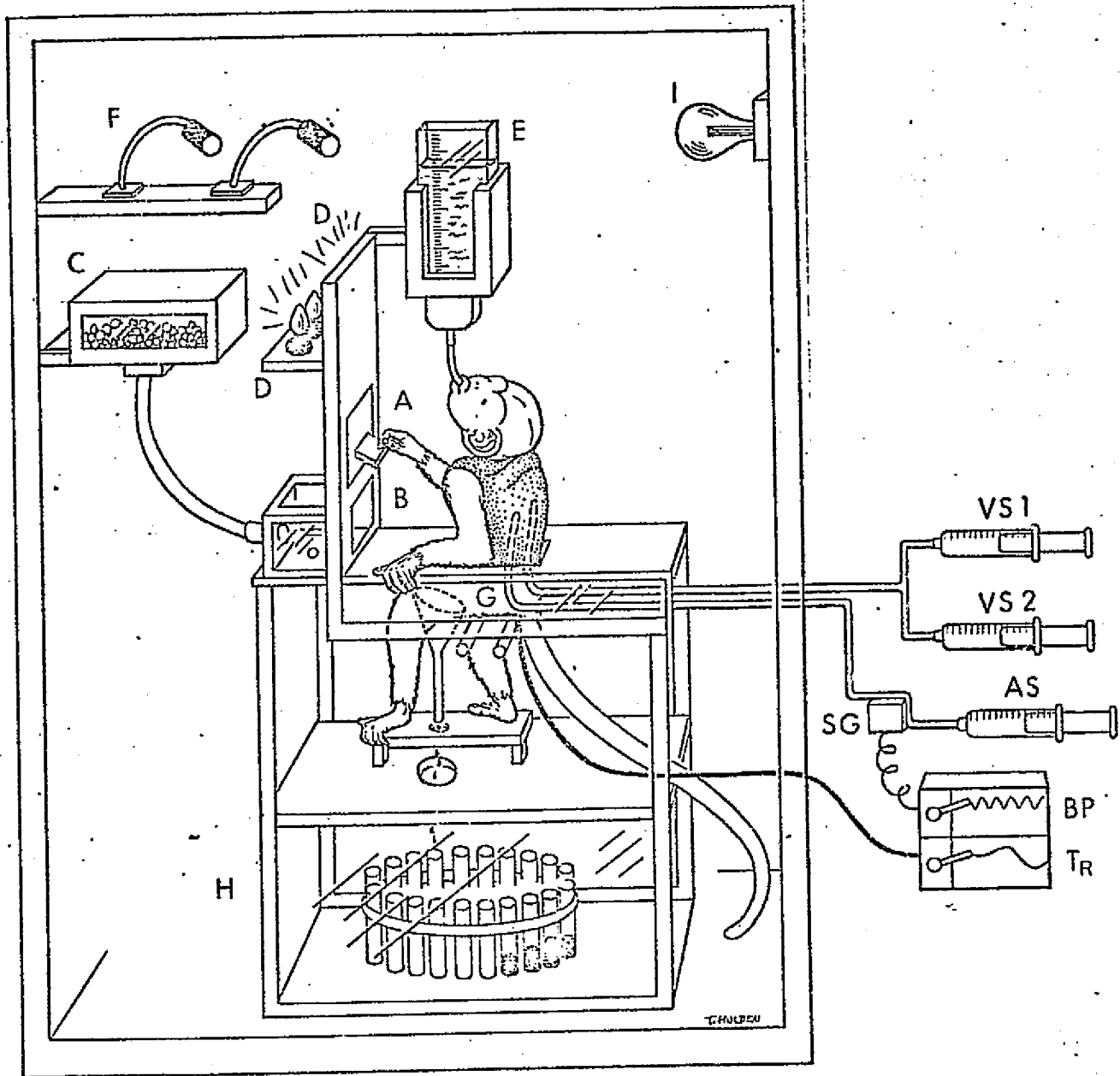

B) First year of research contract

(i) Introduction

In most steady-state situations within an individual subject the various oscillating physiological variables with a circadian period are "internally synchronized" with one another. This means that they demonstrate identical periods and stable phase relationships whether they are synchronized with environmental time cues or free-running in constant conditions.

Previously it had been suggested that the phenomenon of internal synchronization implies that the circadian timing system consists of a single self-sustained oscillator and that circadian rhythms represent passive responses of physiological systems to an oscillating driving force transmitted from the driving oscillator, or "circadian clock". However, it is not necessary to conclude that there is only one oscillator. A multioscillator system would also be compatible with the observed properties of the circadian system provided that the various oscillators were coupled with one another so that internal synchronization was maintained. We accordingly developed three alternative models of the circadian timing system. Each can account for the phenomenon of internal synchronization while at the same time being compatible with the known responses of circadian systems in multicellular animals to manipulations of environmental time cues.

(ii) Alternative models of the circadian timing system

Three models of the circadian timing system are presented in Figure 2. Minor variants of these models, or combinations of their features are also possible, but the models presented here emphasize the contrasts between certain possible organizations of the circadian system.

Model I, which was proposed by Mills but has been assumed in many other investigations of the circadian timing system, consists of a network of cellular systems (A,B,C,..., etc.) which passively oscillate as a forced response to a single self-sustained driving oscillator (D.O.). Where these cellular units are

Figure 2

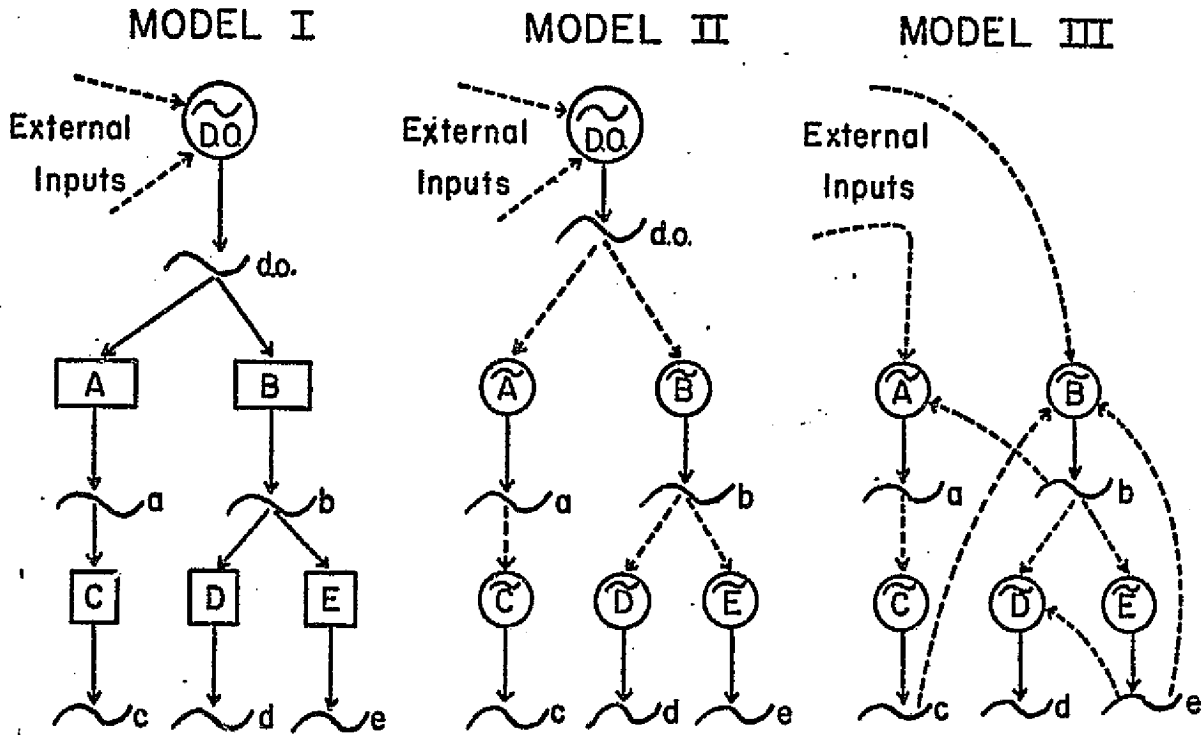

Three alternative models of the mammalian circadian timing system. The symbol \odot represents an active cellular unit capable of maintaining a self-sustained oscillation with its own independent period; \square represents a cellular unit that responds passively to an oscillating driving force; \sim indicates the oscillating concentration of a chemical mediator; \dashrightarrow indicates the entrainment of a self-sustained oscillator by a phase-response mechanism; and \rightarrow is the direction of flow of passive responses to an oscillating driving force. Model I is therefore a single oscillator system whereas the other models are multioscillator systems arranged in a hierarchical (Model II) or non-hierarchical (Model III) manner.

non-contiguous in a multicellular animal, the model requires that oscillating levels of physical or chemical mediators be postulated (a,b,c,..., etc.), with the period of D.O. but not necessarily the same phase. These mediating systems, which would presumably be nervous (neuro-transmitter release) or endocrine (hormonal concentration), would transmit the phase. The entire circadian system would be entrained by environmental time cues via exteroceptive sensory inputs to the driving oscillator.

Model II describes a network of cellular units which are each themselves self-sustained oscillators, able to maintain oscillations with an independent period in the absence of periodic inputs. One oscillator (D.O.) acts as a pacemaker and is entrained by exteroceptive sensory inputs from environmental time cues. As in Model I it is necessary to postulate oscillating nervous or endocrine mediators which maintain synchronization within the animal. However, the mediators in this model actively entrain the self-sustained cellular oscillators by a phase control mechanism similar to the entrainment of the organism's circadian system by cycles of environmental illumination.

Model III also describes a multioscillator model but in this case no one oscillator consistently acts as a pacemaker. Instead the various exteroceptive sensory inputs entrain different oscillators. Internal synchronization within the system is maintained by the positive and negative feedback action of mediators (a,b,c,..., etc.) on the separate oscillating units (A,B,C,..., etc.). As in Model II, the mediators synchronize the oscillators by active entrainment.

(iii) Demonstration that the circadian timing system is an organization of multiple oscillators

Under the first year of this contract we provided strong evidence supporting the concept of a multioscillator circadian system in the squirrel monkey. Wherever there is comparable human data it is strongly suggestive that this multi-oscillator organization is also true for man. The various experiments leading

to this concept were described in the last annual report, but will be summarized here.

We found in the squirrel monkey that circadian rhythms in certain physiological functions take longer to resynchronize after a phaseshift of the environmental light-dark cycle than do others, so that the various monitored circadian rhythms demonstrate different transient periods and altered phase relationships. Seven behavioral and physiological variables were monitored continuously within each individual animal. After an 8 hour phase-delay of a LD 12:12 light-dark cycle, the various monitored rhythms resynchronized at different rates with the new phase of the light-dark cycle (Figure 3). For example, activity, feeding, drinking and body temperature rhythms resynchronized within 3-4 days while the resynchronization of the urinary rhythms of potassium, sodium and water excretion took approximately 7 days.

We have observed prolonged internal desynchronization occurring spontaneously between different rhythmic variables in squirrel monkeys studied in constant light in isolation. An example of such an event is shown in Figure 4. After a monkey had been placed in constant light, the circadian rhythm of body temperature demonstrated a 23.0 hr period whereas the circadian rhythm of feeding had a 26.2 hr period. The length of this particular experiment was too short to determine whether this was a transient internal desynchronization during internal phase angle adjustments or a more steady-state condition. However, in other experiments we have observed internal desynchronization continuing over longer periods of observation.

These demonstrations of internal desynchronization between the circadian rhythms within an organism are incompatible with a single oscillator model but would be predicted by a model, such as II or III in Figure 2 to occur whenever the coupling information between individual oscillators was lost.

Figure 3

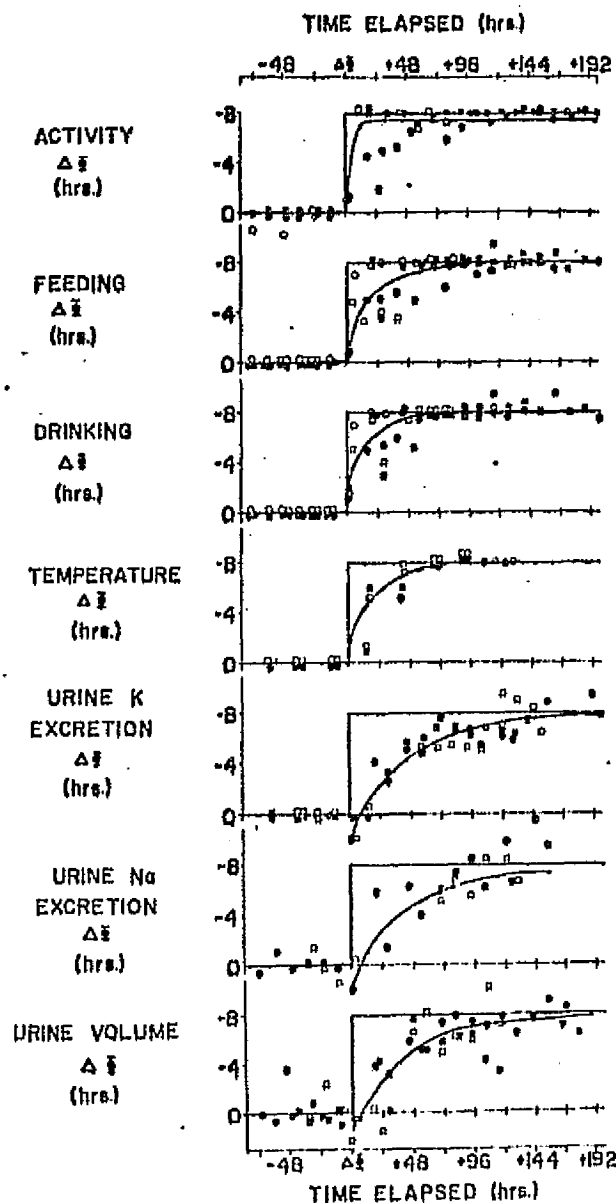

Response of the phase of seven rhythmic variables in squirrel monkeys to an 8-hour phase-delay of the light-dark cycle. Each variable gradually resynchronized with the new light-dark cycle phase but at differing rates so that transient internal desynchronization was observed.

ORIGINAL PAGE IS
OF POOR QUALITY

Figure 4

MONKEY S620C LL

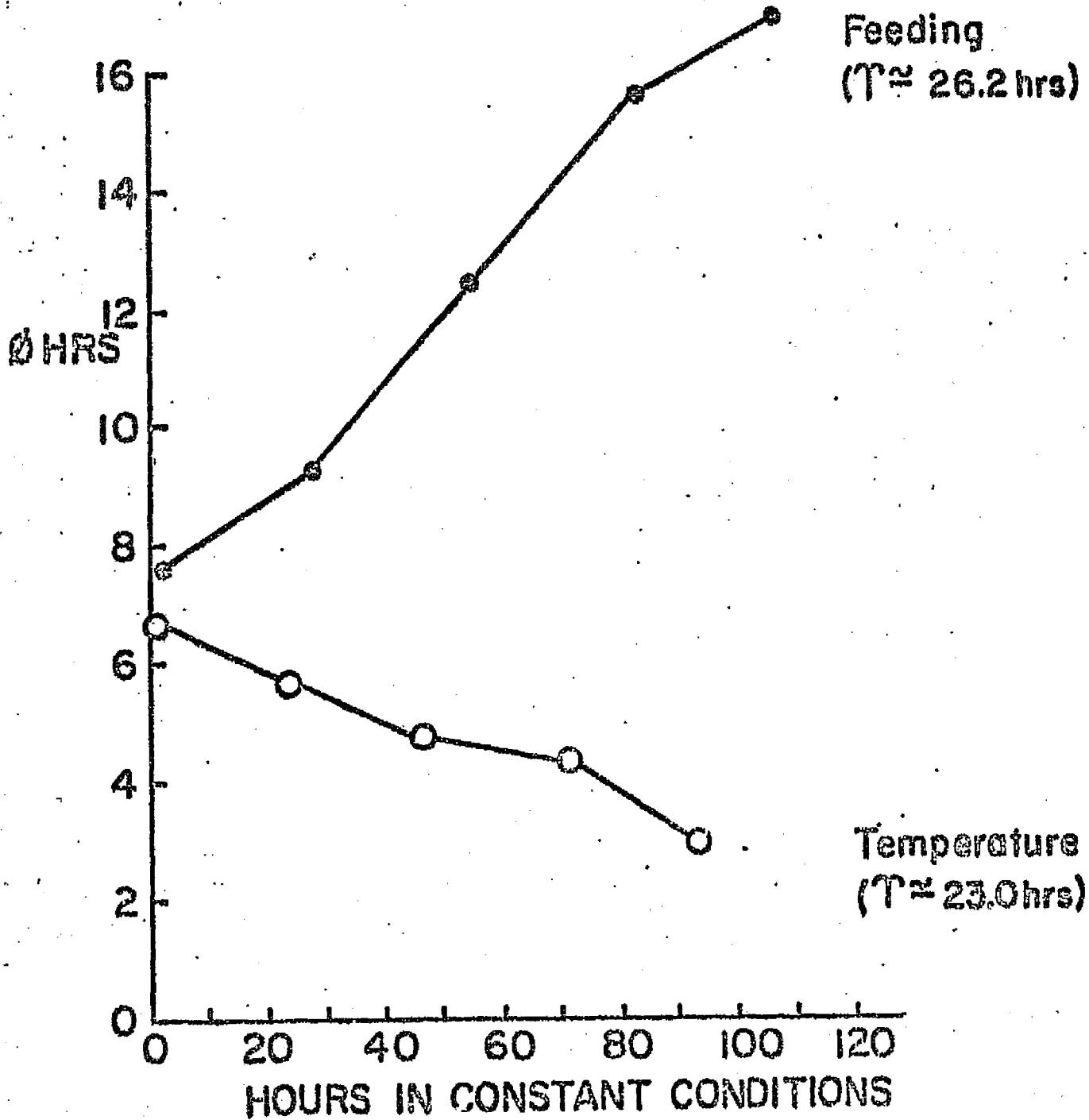

Internal desynchronization of two rhythmic variables (feeding and body temperature) in a squirrel monkey placed in constant conditions (I.L.). The phase of each rhythm determined by phase fitting a 24 hour period sinusoid to successive windows of the time series, is plotted on the ordinate, and elapsed time on the abscissa. Persisting internal desynchronization over much longer periods of time has also been observed.

Concurrent work in the laboratory has borne out another of the predictions of the multioscillator system. We have been able to maintain tissues in vitro and study their rhythmic properties. For example, red blood cells in vitro continue to show circadian rhythms in enzyme activity, suggesting that individual cells have a circadian oscillating capability.

The question of communication between the various oscillators, so that they remain normally internally synchronized, has also been studied. In the first year of this contract we demonstrated that the circadian rhythm of plasma cortisol concentration acted as an internal mediator synchronizing the circadian rhythm of urinary potassium excretion with other rhythms within the organization. Figure 5 shows the effect of phaseshifting the timing of cortisol administration in an adrenalectomized animal when the light-dark cycle was maintained at a fixed phase.

C) Second year research programs

The research performed during the second year of this contract can best be summarized under the following headings:

- (a) Physiological mechanisms promoting normal circadian internal synchronization
- (b) Factors precipitating internal desynchronization
- (c) Pathophysiological consequences of internal desynchronization of particular relevance to spaceflight.
- and (d) Validation of chair-acclimatized system.

Figure 5

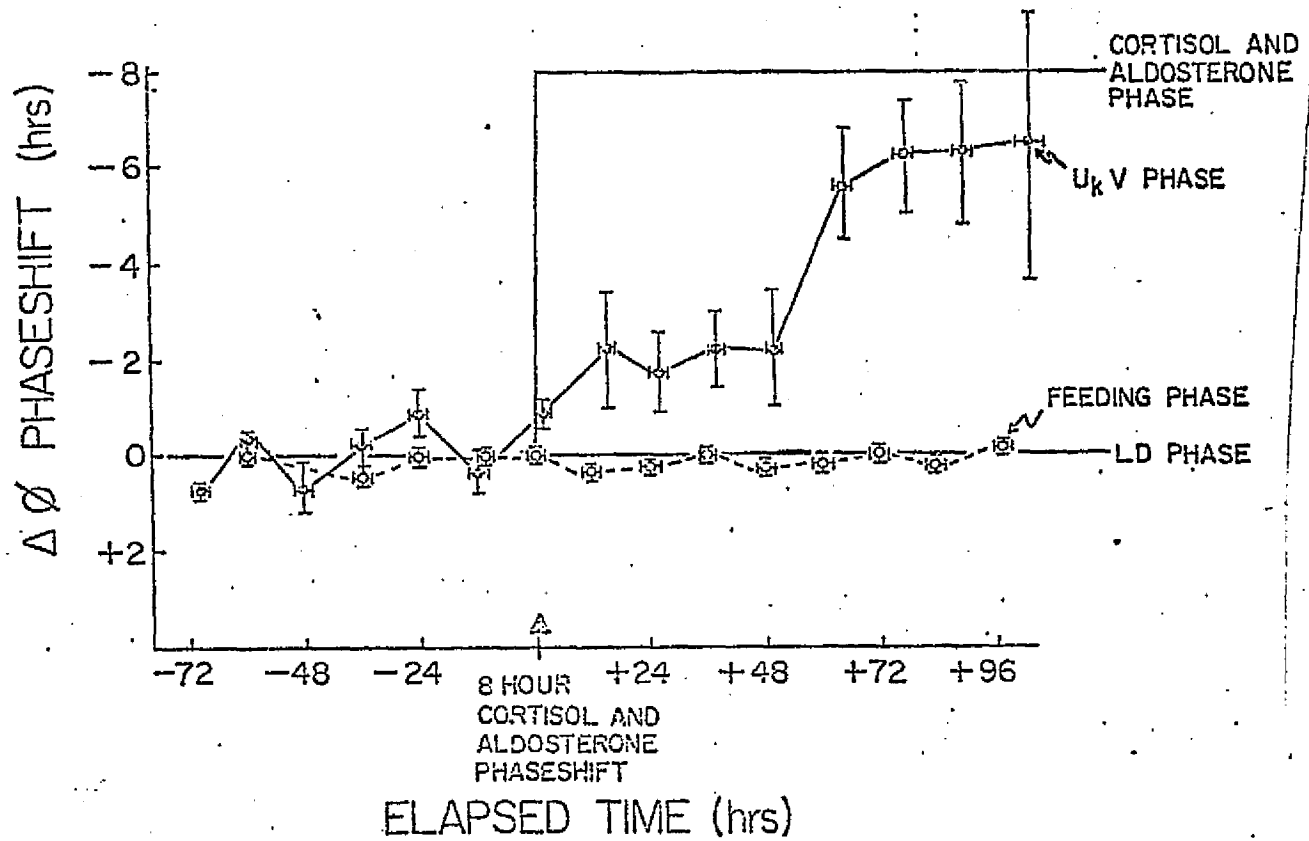

Phaseshifts of the rhythms of urinary potassium excretion (solid line) and feeding (interrupted line) in response to an eight-hour phase-delay of the time of cortisol administration in adrenalectomized squirrel monkeys. The light-dark cycle phase was kept unchanged throughout the experiment. All animals continued to feed with a rhythm synchronized to the light-dark cycle, but the rhythm of urinary potassium excretion resynchronized with the new phase of cortisol administration.

a) Physiological mechanisms promoting normal circadian internal synchronization

These studies were aimed at determining the key physiological mechanisms which were responsible for the internal synchrony of circadian rhythms (particularly of fluid and electrolyte shifts) in the squirrel monkey. Further examinations were made of the (i) role of cortisol, (ii) the role of ACTH and (iii) the role of the putative pacemaker, the suprachiasmatic nucleus (SCN) of the hypothalamus.

(i) In the first year of the contract we showed that the circadian rhythm in plasma cortisol concentration acted as an internal synchronizing mediator in the circadian timing system in the squirrel monkey. In the second year we used this mediator to examine the specificity of this internal mediator, (i.e., did it only synchronize the urinary potassium rhythm?). Using adrenalectomized squirrel monkeys with the circadian rhythms of adrenal steroids controlled by the intravenous infusion of replacement steroids, we studied the actions of this synchronizing mediator in animals maintained in constant conditions in LL so that they are receiving no other external time cues. Whether cortisol entrained all circadian oscillations in the animal to its own period or only synchronized the urinary potassium rhythm could thereby be tested.

Adult male squirrel monkeys were fasted overnight, preoperatively prepared with 0.2 cc of Atrophine Sulphate Solution i/m and then anesthetized with Halothane in oxygen. Bilateral adrenalectomy was performed and a chronically implanted venous catheter was placed in the internal iliac vein and then led out under the skin to the monkey's back. Once adrenalectomized, the animals were given 10 gm cortisol intravenously daily at 08:00 hrs.

After each animal recovered from the adrenalectomy for at least 2 weeks, it was again placed in the metabolism chair and continuous recordings of feeding, body temperature, and urinary potassium, sodium and water excretion were made. The chronically implanted catheters were led outside of the isolation chamber by extension tubing and were infused with 0.45% saline solution at a rate of 10 mg per day. From outside the chamber each day at 08:00 hrs, 10 mg of cortisol was infused into the venous catheter, without the animal being aware of the procedure.

Four animals were studied for 4 days in a light-dark 12:12 cycle with lights on (500 lux) from 08:00 - 20:00 hr daily as in control studies and then for 5-8 days of continuous light (600 lux) with the monkey remaining in isolation. The 08:00 hr daily infusion of 10 mg cortisol was continued throughout LD and LL phases of the experiment. Therefore, during the LL phase the only 24 hourly input to the animal was the cortisol pulse because all other environmental zeitgebers were excluded.

The rhythmic outputs of the different monitored variables were analyzed by linear-nonlinear least squares iterative period analysis, in order to determine whether each variable was oscillating with a 24 hour period or was free-running and therefore not synchronized to the 24 hour rhythm of cortisol administration.

Table I shows the urinary potassium rhythm continued with a period of 24.0 hrs and all other rhythms in the organism in LL had periods significantly different from 24.0 hrs. This suggests that the cortisol synchronizes the urinary potassium rhythm but no other monitored variables in the monkey. This is indicative of the circadian timing system organized in a hierarchical manner as proposed in Model II, and further confirms the role of the circadian rhythm in plasma cortisol as an internal synchronizer of renal potassium circadian rhythms.

Table 1
Periods of Rhythms in LL with Cortisol Daily at 08:00 hrs

Experiment Number	Variable			Days in LL
	Urinary K ⁺	Temperature	Feeding	
1	24.0**	24.5**	25.0**	8
2	24.0**	26.0**	25.0**	5
3	24.0**	25.0**	24.0**	9
4	24.0**	24.5**	24.5*	14

** = $p < 0.01$

* = $p < 0.05$

ORIGINAL PAGE IS
OF POOR QUALITY

(ii) Next we examined the role of plasma ACTH concentration in synchronizing the circadian rhythm of plasma cortisol concentration. It is well known that the pituitary content of ACTH and plasma ACTH concentration have circadian rhythms appropriately phased to the circadian rhythms of adrenal corticosteroid content and plasma corticosteroid concentration so as to suggest a causal connection. To evaluate whether the adrenal cortisol rhythm is under the direct control of plasma ACTH or is synchronized with it in the same manner as we have described for the synchronization of the urinary potassium rhythm by the plasma cortisol rhythm, we have conducted a series of studies in hypophysectomized monkeys given replacement ACTH.

Using the procedure we have developed for hypophysectomy, adult male squirrel monkeys, previously trained to accept chair restraint and the experimental apparatus, were anesthetized by the methods described above and placed in a stereotaxic frame. An 18 gauge steel needle was passed transorbitally into the sella turcica under X-ray visualization. A photograph of the placement of the needle is shown in Figure 6. A dental X-ray machine is used (Raydex) and we have developed a technique using Polaroid film, which is sensitive to X-rays, to provide superior and lateral shots of the needle placement. Multiple shots were taken as the needle is directed into the sella turcica.

Once the position of the needle was confirmed in three dimensions by X-ray, a stainless steel electrode insulated except for 0.5 mm at the tip was passed through the needle so that the tip was in the sella turcica and a current of 3 mA was passed for 60 seconds before the needle and electrode were withdrawn. The complete destruction of anterior pituitary tissue is verified by subsequent histology after the experiments are completed. Care is taken not to damage the contents of the sella turcica at the time of removal of the specimen from the skull and standard histological techniques are used.

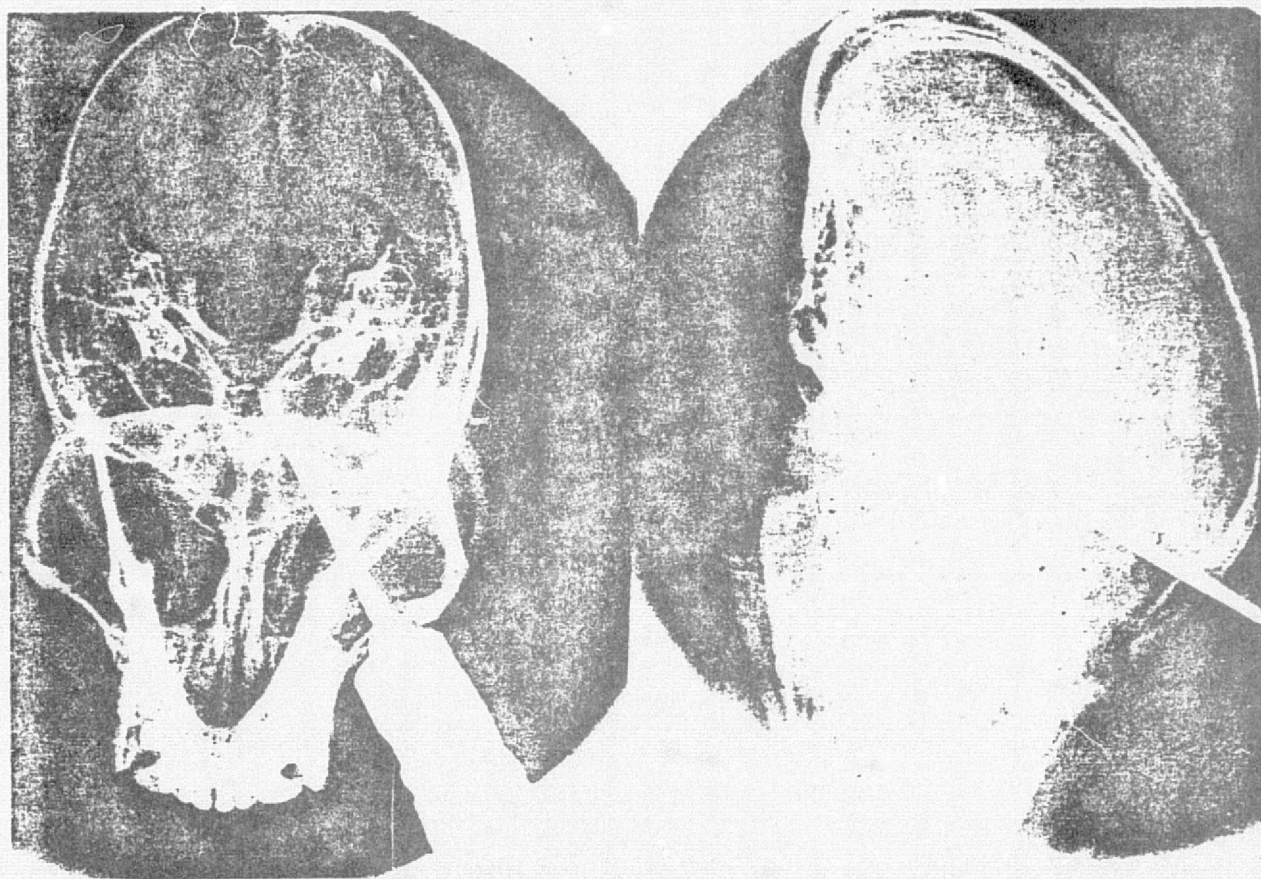

Figure 6. Superior and lateral views of the needle and electrode placement in the sella turcica of a squirrel monkey during hypophysectomy.

ORIGINAL PAGE IS
OF POOR QUALITY

Once the animal is hypophysectomized, it was maintained with i/m daily injections at 08:00 hrs of 2 units of ACTH (Acthar gel, Armour Pharmaceutical Company). [Note that the squirrel monkey has a relatively hyperactive pituitary-adrenal system]. We have not found it necessary to supplement the animals during the first two to three months with any other replacement hormones and they appear to maintain body weight provided the regular ACTH replacement is given.

At least two weeks after operative procedures have been completed, the unanesthetized trained animals were placed within the metabolism chair in the isolation chamber. The arterial catheter was extended to the outside of the chamber to permit uninterrupted sampling. The venous catheter was connected up to an infusion syringe outside the chamber providing 10 cc of 0.45% saline daily as a continuous infusion. This pump was set up in parallel with another pump containing 3 units of ACTH (lyophilized Acthar for injection) in 3 ml of 0.45% saline solution. An automatic timer switched on the ACTH and saline pump from 06:00 hrs to 09:00 hrs daily and at the same time switched off the syringe pump with only saline in it. Thus the monkey receives under control conditions a standard 3 hourly infusion of ACTH which is repeated every 24 hours. At the same time the circadian rhythms of feeding, drinking and activity, body temperature and urinary potassium, sodium and water excretion are continuously monitored with the animal in an LD 12:12 cycle.

With the animal remaining in LD 12:12 throughout, 3 units of ACTH were infused for 4 days between 06:00 and 09:00 hrs. On the fifth day and thereafter, the same dose of ACTH was infused 8 hours later between 14:00 and 17:00 hrs daily. Thus, the animal was subjected to an 8 hour phase-delay in the time of ACTH administration while all other parameters are held constant. In each case the urinary potassium rhythm resynchronized with respect to the new phase of ACTH administration thus confirming that the pituitary-adrenal axis played a role in the internal synchronization of this renal electrolyte rhythm.

(iii) The identification of a driving oscillator would do much to help distinguish between the models of the circadian timing system we have discussed. Studies in rodents have now indicated that the bilateral hypothalamic supra-chiasmatic nuclei (SCN) in these species appear to contain an oscillator or coupled group of oscillators which play a central role in the generation of circadian rhythmicity. Because we have the capability to continuously monitor several physiological and behavioral rhythms for periods of several weeks in individual animals, we can study the function of the SCN in the squirrel monkey and determine if they contain oscillator(s) which play a central timekeeping role. Our studies of the role of the suprachiasmatic nucleus (SCN) as a putative central pacemaker in the squirrel monkey have made considerable progress in what has proved to be a problem with major technical demands.

Male adult squirrel monkeys were fasted overnight, preoperatively prepared with 0.2 cc atropine sulphate solution i/m and then anesthetized with Halothane in oxygen. The animals were placed in a stereotaxic frame (David Kopf Instruments). Stainless steel electrodes, insulated except for 0.25 mm at the tip, are placed according to coordinates derived from the atlas of Emmers and Akert, as a first approximation, using animals in the zero correction range of Brown, et. al. An anodal current of 3 mA for 15-20 seconds is then passed using a Stoetling lesion producing device.

It should be noted that the SCN in the squirrel monkey is approximately 1 mm long, 0.5 mm wide and 0.4 mm high, and that the coordinates even between successive sections in the atlas may vary by 0.5 mm or more especially in the vertical plane. For this reason, we chose settings for the electrical current which generate a lesion, by our technique, of between 1 and 2 mm diameter in squirrel monkeys. This we found optimizes the chances of destroying the SCN while minimizing the destruction of neighboring areas of the hypothalamus. The anatomical location of all lesions were determined by standard histological procedures after the experimental work was completed on the animals.

ORIGINAL PAGE IS
OF POOR QUALITY

Healthy monkeys were conditioned to accept chair-restraint and experimental procedures. Before lesions were placed, control data was collected both with the monkeys a) free-ranging in their cages in isolation and b) chair-restrained. Each animal was studied for one week with a LD 12:12 cycle and then for at least two weeks of LL isolation in the free-ranging cage. The circadian rhythms of locomotor activity, feeding and drinking were continuously monitored.

These control studies established a) that the rhythms observed were representative of those seen in the several hundred such squirrel monkeys experiments previously undertaken by this laboratory, b) that the animals were normally synchronized by the light-dark cycle, c) the free-running period of the animals under the conditions of the experiment in LL and d) whether internal synchronization is observed between monitored rhythms in LD and LL.

At least two weeks after the control experiments were completed, the monkeys were given bilateral suprachiasmatic lesions, and allowed to "recover" a minimum of at least 2 weeks prior to the next chair experiment. However, during the recovery phase, and all other times that the animal was not in a chair, it was maintained in a cage in isolation with feeding, drinking and activity monitored.

The studies conducted on these animals have demonstrated that lesions in the hypothalamus but not damaging the SCN have no effect on the rhythmic structure of the organism. However, lesions which destroyed a SCN caused effects on the circadian rhythm of activity which were comparable to those seen in rodents. However, a detailed study of these effects was not possible in the short-term of this contract. We would hope to continue this work now that our methodology is highly developed, and the preliminary experiments look promising.

b) Factors precipitating internal desynchronization

Although normally various components of the circadian timing system are internally synchronized with one another it can be demonstrated that on occasion internal desynchrony occurs so the various components start oscillating with independent frequencies, thus losing temporal coordination with one another. As was noted above internal desynchronization can occur spontaneously in both man and the squirrel monkey. One aspect of the current research contract was to explore the factors which might lead to an increased incidence of internal desynchronization.

We have previously discussed how internal desynchronization could well be caused by circadian arrhythmias in hormonal mediators. We can clearly show such effects by infusing cortisol in adrenalectomized monkeys at a constant rate. However, the major purpose of the current contract was to examine environmental conditions which might lead to internal desynchronization and get some idea of the various factors in the squirrel monkey which precipitated this particular condition. It should be pointed out that the only species besides man where internal desynchronization has clearly been documented is the squirrel monkey. Thus, this experimental preparation serves as a unique human surrogate in this respect.

As a first step in this research various environmental factors which acted as time cues in the squirrel monkey were examined. Animals were placed in constant conditions for period of up to 6 months while various potential environmental factors were tested as time cues. During the 2-3 week period of testing for each zeitgeber an environmental cycle of this particular zeitgeber was applied while all other conditions in the environment were held constant. It was found that circadian oscillations in warm-cool (12 hrs at 30°C and 12 hrs at 20°C), social-isolation (12 hrs in the company of another monkey and 12 hrs

isolated), sound (12 hrs at 100 dB and 12 hrs at 70 dB provided at 2 minute bursts every 15 minutes), were not effective as zeitgebers. The light-dark cycle was, however, demonstrated to be a potent zeitgeber, as was already known, and in addition the timing of food availability in the squirrel monkey was found to be a very potent zeitgeber. (Figure 7).

These experiments demonstrated that the internal and external synchronization of the squirrel monkey could only be modulated by two particular environmental agents: 1) the environmental lighting and 2) the environmental food supply. Further experiments were conducted to determine the role of different levels of these in promoting internal synchronization.

Animals were subjected to either constant light at 60 lux or constant light at 600 lux. It was found that internal desynchronization occurred in both of these conditions. This demonstrated that the occurrence of internal desynchronization did not appear to be similar to the occurrence of rhythm-splitting in which light intensity appeared to be a key factor. To fully answer this point, however, it will be necessary to examine a much wider range of light intensities, a particularly time consuming experiment. We also examined the role of different lengths of food administration on the internal and external synchrony of the rhythms of the animal. It was found that 1 or 2 hour periods of feeding per day were not sufficient to synchronize the animal, or in some cases appeared to produce an internal desynchronization with some functions following feeding and others following their own free-running period. However, when a 3 hour period of food availability was allowed each day all functions appeared to synchronize to this.

One other factor which appears to be related to the occurrence of internal desynchronization is stress. We have previously discussed how various pieces of evidence in the literature would point to this effect. To study this question

Figure 7. Examination of potential zeitgebers in the squirrel monkey.

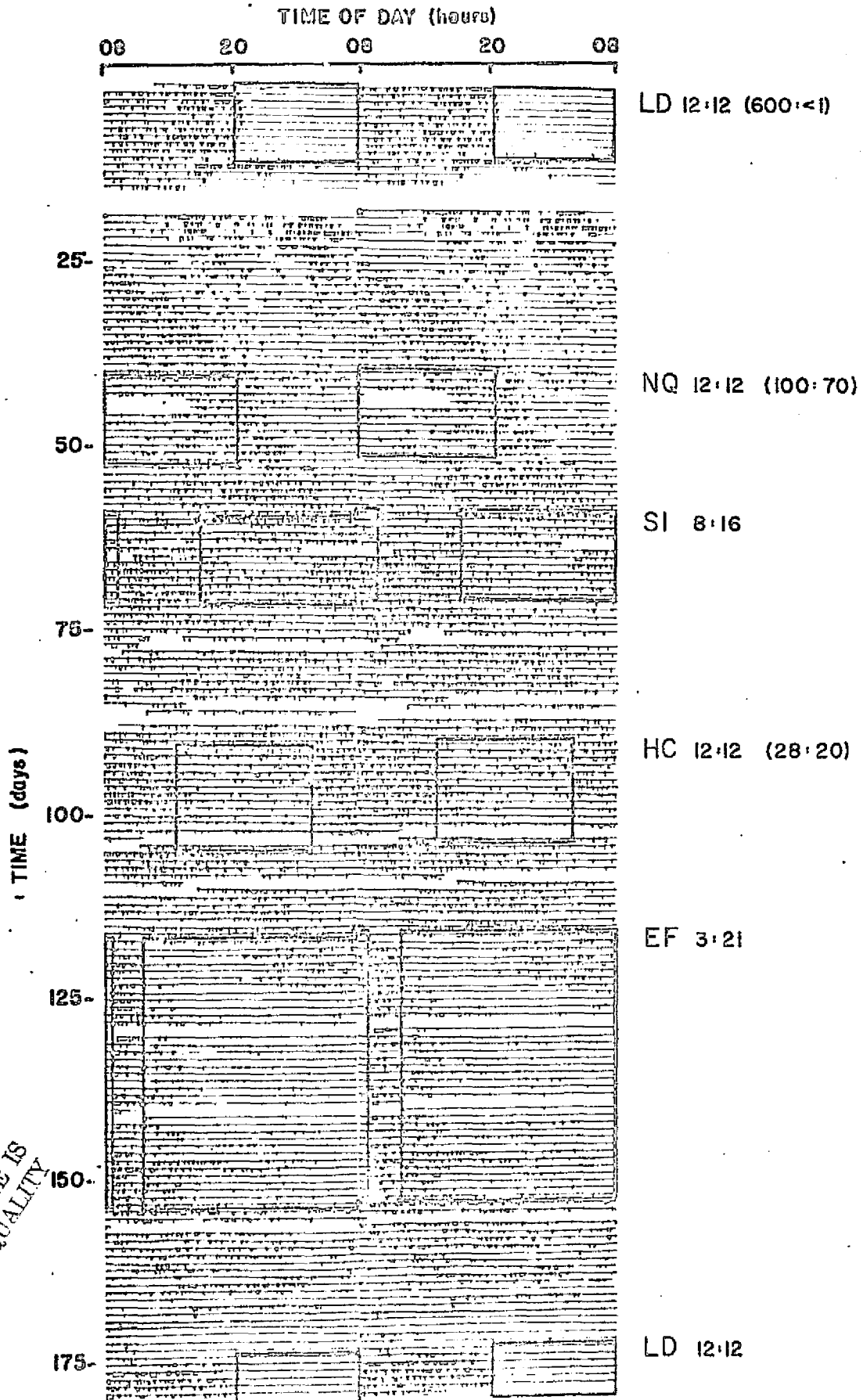

ORIGINAL PAGE IS
OF POOR QUALITY

in a preliminary manner we have examined monkeys who were relatively naive to the chair and compared these animals with those who have been experienced over several months to the experimental apparatus. We have observed internal desynchronization in both groups of animals but as yet there is insufficient data to tell us whether it is more common in the inexperienced vs. the experienced group.

c) Pathophysiological consequences of internal desynchronization of particular relevance to spaceflight

As an outgrowth of our studies of the effect of warm-cool cycles on circadian rhythms in the squirrel monkey a major, previously unobserved, finding was obtained. We found that animals which were internally synchronized either by feeding or by light-dark cycles maintained body temperature very effectively during exposure to a drop in environmental temperature of 8°C, but animals which were in constant conditions and apparently internally desynchronized showed a major fall in body temperature. (Figure 8).

Although there have been previous reports of decrements in performance in internally desynchronized subjects as compared to controls, there has been little evidence showing direct pathophysiological consequences of internal desynchronization. The finding of the reduced capability of dealing with environmental temperature challenges is of great importance therefore. We have spent some effort of this last contract year in elucidating the mechanisms that might be involved.

As soon as various potential components of body temperature regulation are measured, such as heat loss mechanisms and heat gain mechanisms, it becomes apparent that on occasion that these can dissociate from each other when the animal is free-running under constant conditions. Thus the rhythm of body temperature loss from the tail can be oscillating with a different frequency

Figure 8. Effect of Cold Pulse on Body Temperature

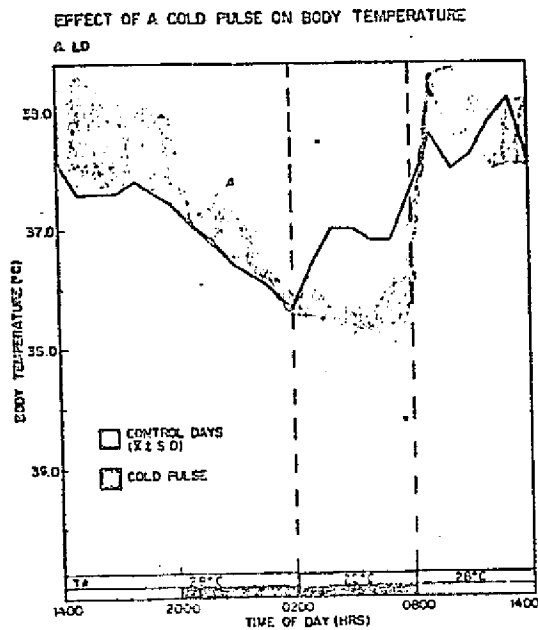

D. LL

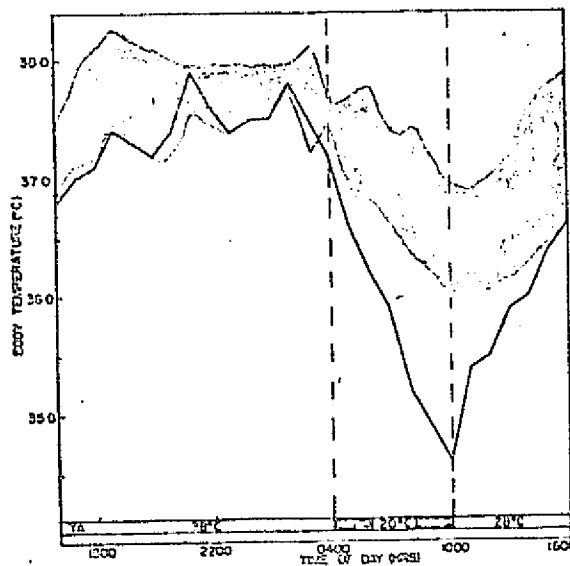

ORIGINAL PAGE IS
OF POOR QUALITY

Shaded area is the mean \pm SD of the temperature rhythms for the previous three days. The solid line is body temperature on the day that the cold pulse was administered.

to the rhythm of core body temperature.

We have further investigated situations in which internal desynchrony is well documented such as adrenalectomized animals provided with 08:00 hr pulses of cortisol each day where the urinary potassium rhythm is synchronized to the 24 hour period of cortisol administration and the other rhythms that we observe in this animal are free-running. When we apply cold pulses in such animals we get major effects with reductions in body temperature of up to 3°C. However, the same animals studied in light-dark cycles where they are internally synchronized show no such susceptibility to drops in environmental temperature.

These findings are, we believe, of great importance to spaceflight. In space there is an increased risk of internal desynchronization because of stress and potentially insufficient temporal cues from the environment. Thus, the Biosatellite III Macaca nemistrina monkey showed internal desynchronization apparently from the limited data that was available. That we have shown an important physiological consequence, and one of such significance in space such as the inability to deal with variations in environmental temperature, is most important. We feel this deserves considerable study because it is a potential future spaceflight hazard.

d) Comparison of chair and cage situations

The chair-acclimatized preparation which we developed in this apparatus has been of considerable use in analyzing the circadian timing system in the squirrel monkey. It provides the capability for studying a number of variables continuously without being restricted by measurement or drug administration problems. Because of the uniqueness of this chair-acclimatized preparation and because it does provide restraint of the animals we have conducted a series of studies of comparing similar experiments conducted in monkeys free-running in the cage. In the variables that we have been able to monitor in this regard we have been able to

demonstrate that the circadian rhythms are to all intents and purposes identical in the cage and chair, thus demonstrating the applicability of our chair-acclimatized preparation.

IV. List of Publications

The work performed under this contract for years 1974-75 and 1975-76 has been published or will be published in the following papers. Reprints are enclosed.

1. Moore-Ede, M.C.; Brennan, M.F.; and Ball, M.R.: Circadian variation of intercompartmental potassium fluxes in man. *J Appl Physiol* 38: 163-170, 1975.
2. Moore-Ede, M.C.; and Herd, J.A.: Renal electrolyte circadian rhythms: independence from feeding and activity patterns. *Am J Physiol* In Press, 1976.
3. Czeisler, C.A.; Moore-Ede, M.C.; Regestein, Q.R.; Kisch, E.S.; Fang, V.S.; and Ehrlich, E.N.: Episodic 24-hour cortisol secretory pattern in patients awaiting elective cardiac surgery. *J Clin Endocrinol Metab* 42: 273-283, 1976.
4. Moore-Ede, M.C.; Schmelzer, W.S.; Kass, D.A.; and Herd, J.A.: Internal organization of the circadian timing system in multicellular animals. *Fed Proc*, In Press, 1976.
5. Moore-Ede, M.C.; Kass, D.A.; and Herd, J.A.: Transient circadian internal desynchronization after light-dark phaseshift in monkeys. *Am J Physiol*, In Press, 1976.
6. Moore-Ede, M.C.; Czeisler, C.A.; Schmelzer, W.S.; and Kass, D.A.: Circadian internal desynchronization induced by circadian arrhythmias in synchronizing mediators: an etiological hypothesis. *Chronobiologia*, In Press, 1976.
7. Moore-Ede, M.C.: Circadian rhythms in drug effectiveness and toxicity in shiftworkers. National Institute of Occupational Safety and Health Report. In Press, 1975.
8. Moore-Ede, M.C.; Schmelzer, W.S.; and Herd, J.A.: Synchronization of the circadian rhythm of renal potassium excretion by circadian oscillations in adrenal steroid secretion. In "Rhythmic Functions in Biological Systems" edited by Seitelberger, F. and Lassman, G. In Press, 1975.
9. Moore-Ede, M.C.; Meguid, M.M.; Fitzpatrick, G.F.; Boyden, C.M.; and Ball, M.R.: Circadian variation in response to potassium infusion in man. Submitted to *J Clin Invest*, 1976.

10. Sulzman, F.M.; Fuller, C.A.; and Moore-Ede, M.C.: Specificity of cortisol as a mediator of circadian rhythms in the squirrel monkey. Submitted to J Comp Physiol, 1976.
11. Moore-Ede, M.C.: Internal synchronization of spontaneous circadian oscillators: The identification of the hormonal mediator synchronizing a renal oscillator. Presented at the Symposium on "Physiological and Biochemical Aspects of Circadian Rhythms" at the 59th Annual Meeting of the Federation of American Societies for Experimental Biology, Atlantic City, New Jersey April 15, 1975.
12. Moore-Ede, M.C.; Czeisler, C.A.; Schmelzer, W.S.; and Kass, D.A.: Circadian internal desynchronization: Causation by circadian arrhythmias in hormonal mediators? Presented at the Annual Meeting of the International Society for Chronobiology, Washington, D.C., August 12, 1975.
13. Moore-Ede, M.C.; Schmelzer, W.S.; and Herd, J.A.: Plasma cortisol oscillations synchronize the circadian rhythm of renal potassium excretion in the squirrel monkey. Presented at the International Congress on "Rhythmic Functions in Biological Systems", Vienna, Austria, September 9, 1975.
14. Moore-Ede, M.C.: Organization of the mammalian circadian timing system. Presented at the 4th Annual Meeting of New England Physiologists, Boston, Massachusetts, November 22, 1975.
15. Sulzman, F.M.; Schmelzer, W.S.; Fuller, C.A.; Zimmerman, J.C.; and Moore-Ede, M.C.: Specificity of cortisol as an internal synchronizer of circadian rhythms in the squirrel monkey. Fed Proc 35: 694, 1976.
16. Fuller, C.A.; Sulzman, F.M.; Schmelzer, W.S.; Zimmerman, J.C. and Moore-Ede, M.C.: Modification of thermoregulation in squirrel monkeys in the absence of circadian light-dark cycles. Fed Proc 35: 724, 1976.
17. Moore-Ede, M.C.: Circadian timing system in man: Physiology and pathology of an organization of multiple synchronized oscillators. Presented at the XXIst International Congress of Psychology, Symposium No.21 on "Biological Rhythms and Behavior", Paris, France July, 1976. p.131.
18. Moore-Ede, M.C.; Meguid, M.M.; Fitzpatrick, G.F.; Ball, M.R., and Boyden, C.M.: Circadian variation in intravenous potassium tolerance. Clin Res, 1976.

V. EQUIPMENT PURCHASED BY NASA GRANT 9610

Pellet Dispensers (5), Ralph Gerbrands Co.	\$ 642.00
Model 20 Incubator (Modified) (3), Forma Scientific Co.	2079.60
Harvard Cummulative Recorder (1), Ralph Gerbrands Co.	770.00
6-Pen Event Recorder (3), Ralph Gerbrands Co.	500.00
Total for 7/1/74 - 6/30/75:	<hr/> \$4211.60
Multiplexer 48 Channel and Cable Assembly, Stoelting Co.	\$3808.00
Total for 9/1/75 - 12/31/75:	<hr/> \$3808.00
80 mA Pluse, Internal Sensor 30-45°C, Konisberg Instruments (2)	\$ 790.00
Combination Receiver/Deodulator FM & Pulse, Konisberg Instruments (2)	\$1300.00
Total for 6/1/75 - 8/31/76:	<hr/> \$2090.00

William E. Hassau, Jr., Ph.D.
Director

Herbert L. Abrams, M.D.
Radiologist-in-Chief

Eugene Braunwald, M.D.
Physician-in-Chief

Ramzi S. Cotran, M.D.
Pathologist-in-Chief

Samuel Hellman, M.D.
Radiotherapist-in-Chief

Francis D. Moore, M.D.
Surgeon-in-Chief

Clement B. Sledge, M.D.
Orthopedist-in-Chief

Leroy D. Vandam, M.D.
Anesthesiologist-in-Chief

PETER BENT BRIGHAM HOSPITAL

721 Huntington Avenue, Boston, Massachusetts 02115 (617) 734-8000

October 1, 1975

Dr. John A. Rummel, Ph.D.
Chief, Environmental Research Branch
National Aeronautics and Space Admin.
Lyndon B. Johnson Space Center
Houston, Texas 77058

Dear John,

This letter will serve as the first monthly report of the renewal of NASA contract NAS9-14249.

The laboratory effort has been strengthened by the addition of two post-doctoral fellows, Dr. Charles Fuller and Dr. Frank Sulzman, and the part-time assistance of a computer specialist. This month has been spent in automating a number of the data collection procedures in the laboratory and conducting pilot studies for the work to be performed under the renewal of this contract.

Dr. Charles Fuller has special experience in thermoregulation and is particularly interested in the control of the circadian rhythm of body temperature and its implications for mammalian thermoregulation. He has developed during this month routine procedures for continuously monitoring body temperature (colonic temperature) in all our animals simultaneously and we now have this as a routine control variable for all our experiments.

With best wishes,

Sincerely yours,

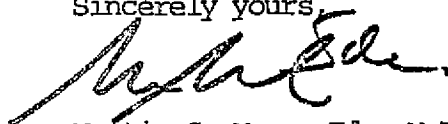

Martin C. Moore Ede, M.B., B.S., Ph.D.
Assistant Professor of Physiology

MCME/msc

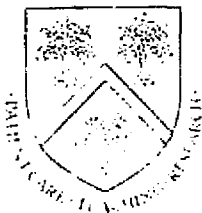

A Teaching Hospital
of the
Harvard Medical
School

PRECEDING PAGE BLANK NOT FILMED

Director

Herbert L. Abrams, M.D.
Radiologist-in-Chief

Eugene Braunwald, M.D.
Physician-in-Chief

Ramzi S. Cotran, M.D.
Pathologist-in-Chief

Samuel Hellman, M.D.
Radiotherapist-in-Chief

Francis D. Moore, M.D.
Surgeon-in-Chief

Clement B. Sledge, M.D.
Orthopedist-in-Chief

Leroy D. Vandam, M.D.
Anesthesiologist-in-Chief

PETER BENT BRIGHAM HOSPITAL

721 Huntington Avenue, Boston, Massachusetts 02115 (617) 734-8000

November 1, 1975

Dr. John A. Rummel, Ph.D.
Chief, Environmental Research Branch
National Aeronautics and Space Admin.
Lyndon B. Johnson Space Center
Houston, Texas 77058

Dear John,

This letter will serve as the second monthly report on the renewal of NASA contract NAS9-14249.

We have been conducting a fascinating series of studies this month on the role of cortisol in the internal synchronization of squirrel monkeys. As you know, we have previously demonstrated that cortisol plays an important role in synchronizing circadian rhythm of urinary potassium excretion. To find how general is the role of cortisol in internal synchronization of circadian rhythms, and to investigate whether the organization of the circadian multioscillator system in primates is hierarchical or nonhierarchical, we have conducted a series of studies with cortisol pulses being given to animals free-running in isolation in constant light.

In this series of studies squirrel monkeys were administered cortisol at 08:00 hr each day but were maintained in constant light in isolation. What was found was that the circadian rhythms of body temperature and feeding activity continued to free run with the same periods as they had done in intact control animals in constant light, but that the circadian rhythm of urinary potassium excretion was synchronized by the 24 hourly pulse of cortisol administered at 08:00 hr each day. Therefore, the urinary potassium rhythm was found to be synchronized to a 24 hr cycle. This study is most interesting because it indicates that the administration of cortisol with a regular 24 hr period does not synchronize the entire circadian system, as might have been predicted from our knowledge of feed-back mechanisms of cortisol on the pituitary-adrenal axis and the hypothalamus, but instead acts as a synchronizer only to certain oscillators in the body. This work is currently being drafted up for an abstract to be presented at the Federation Meeting next year. Particularly responsible for this series of studies is Dr. Frank Sulzman.

With best wishes,

Sincerely yours,

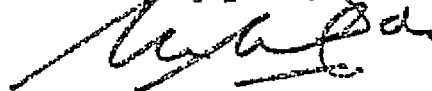

Martin C. Moore Ede, M.B., B.S., Ph.D.
Assistant Professor of Physiology

MCME/msc

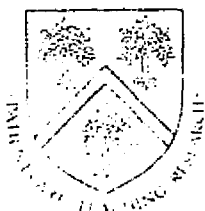

A Teaching Hospital
of the
Harvard Medical
School

Walter G. Hassen, Jr., Ph.D.
Director

Herbert L. Abrams, M.D.
Radiologist-in-Chief

Eugene Braunwald, M.D.
Physician-in-Chief

Ramzi S. Cotran, M.D.
Pathologist-in-Chief

Samuel Hellman, M.D.
Radiotherapist-in-Chief

Francois D. Moore, M.D.
Surgeon-in-Chief

Clement B. Sledge, M.D.
Orthopedist-in-Chief

Leroy D. Vandam, M.D.
Anesthesiologist-in-Chief

PETER BENT BRIGHAM HOSPITAL

721 Huntington Avenue, Boston, Massachusetts 02115 (617) 734-8000

December 1, 1975

Dr. John Rummel, Ph.D.
Chief, Environmental Research Branch
National Aeronautics and Space Admin.
Lyndon B. Johnson Space Center
Houston, Texas 77058

Dear John,

This letter will serve as the third monthly report on the renewal of NASA contract NAS9-14249.

As was spelled out under Contractor Task 4.3 in this renewal of the contract, we have been interested to try to answer the question whether there is a single circadian pacemaker in the brain which serves a role in driving the circadian multi-oscillating system. Previous work in other laboratories has suggested that the supra-chiasmatic nucleus plays an important role as a circadian pacemaker. However, the fundamental flaw of these studies, conducted in rodents, has been that they have treated the circadian system as a system with only one clock. In other words, they have not considered it as a multi-oscillating system.

In our series of studies, we have monitored a large number of physiological variables in the squirrel monkey and have studied these animals before and after placing lesions in the region of the supra-chiasmatic nucleus. These studies by their nature are somewhat long term in that it takes several weeks to gather the initial data on the animal, and then several weeks after the lesion is placed to determine the effect on the internal synchronization of the circadian system, before histology and sectioning can be done.

Over the first two months of this contract we have made an impressive headstart on this program, using the skills of Dr. Charles Fuller, who has experience in stereotaxic surgery and hypothalamic neurofunction study. He has developed techniques for stereotaxic lesioning in our squirrel monkey preparation and to date we have placed lesions in two animals and are studying their effects.

Over the last month or so, we have also made considerable progress in the computer analysis of our data. Besides our routine data storage techniques, and the development of some very useful graphical plotting techniques from our laboratory, we have utilized in conjunction with Dr. R. Kronauer of the Division of Engineering and Applied Physics a procedure of multiple band pass

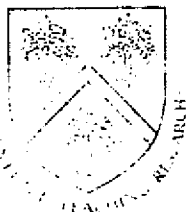

A Teaching Hospital
of the
Harvard Medical
School

filter analysis, which enables us to detect the various frequencies in a time series data string, differentiate them from one another and examine their phase relationship. Using this program we can deal with non-perfect biological oscillating data because the band pass filters have considerable tolerance to small changes in frequencies and phase. Using this technique we are now able to analyze data which previously was extremely difficult to analyze by the least-squares regression technique.

With best wishes,

Sincerely yours,

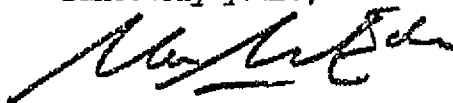

Martin C. Moore Ede, M.B., B.S., Ph.D.
Assistant Professor of Physiology

MCME/msc

12/1/75

William E. Hassan, Jr., Ph.D.
Director

Herbert L. Abrams, M.D.
Radiologist-in-Chief

Eugene Braunwald, M.D.
Physician-in-Chief

Ramzi S. Cotran, M.D.
Pathologist-in-Chief

Samuel Hellman, M.D.
Radiotherapist-in-Chief

Francis D. Moore, M.D.
Surgeon-in-Chief

Clement B. Sledge, M.D.
Orthopedist-in-Chief

Leroy D. Vandam, M.D.
Anesthesiologist-in-Chief

PETER BENT BRIGHAM HOSPITAL

721 Huntington Avenue, Boston, Massachusetts 02115 (617) 734-8000

January 1, 1976

Dr. John A. Rummel, Ph.D.
Chief, Environmental Research Branch
National Aeronautics and Space Admin.
Lyndon B. Johnson Space Center
Houston, Texas 77058

Dear John,

This letter will constitute the fourth monthly report on the renewal of NASA contract NAS9-14249.

We are now making considerable progress in the third portion of the renewal of this contract documented as Contractor Task 4.2. We have been studying the role of pituitary ACTH secretion in the synchronization in the rhythm of cortisol secretion and in the functions which are normally synchronized by that cortisol rhythm.

Because of the importance of the circadian rhythm of cortisol output by the adrenal in the synchronization of certain circadian functions, we have been examining the role of ACTH in synchronizing the adrenal cortisol rhythm. We have been particularly interested in the questions whether the adrenal gland acts as its own independent oscillator, as studies in isolated tissues would suggest, and how the circadian rhythm of ACTH output by the pituitary might synchronize this.

We have developed the technique of hypophysectamizing squirrel monkeys using a trans-orbital approach. We insert a trocar through the medial side of the orbit and direct it under X-ray visualization into the sella turcica. An electrode is then passed down through the needle into sella turcica and a current is passed to coagulate the pituitary. The animals are then prepared with implanted venous catheters and each day are maintained by administering them ACTH at 08:00 hr. We are currently setting up the experiments so that we can infuse ACTH automatically and study whether phase-shifts of ACTH will phase-shift the adrenal cortisol rhythm.

With best wishes,

Sincerely yours,

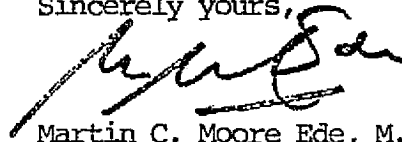

Martin C. Moore Ede, M.B., B.S., Ph.D.
Assistant Professor of Physiology



A Teaching Hospital
of the
Harvard Medical
School

William E. Glasson, Jr., Ph.D.
Director

Herbert L. Abrams, M.D.
Radiologist-in-Chief

Eugene Braunwald, M.D.
Physician-in-Chief

Ramzi S. Cotran, M.D.
Pathologist-in-Chief

Samuel Hellman, M.D.
Radiotherapist-in-Chief

Francis D. Moore, M.D.
Surgeon-in-Chief

Clement B. Sledge, M.D.
Orthopedist-in-Chief

Leroy D. Vandam, M.D.
Anesthesiologist-in-Chief

PETER BENT BRIGHAM HOSPITAL

721 Huntington Avenue, Boston, Massachusetts 02115 (617) 734-8000

February 1, 1976

Dr. John A. Rummel, Ph.D.
Chief, Environmental Research Branch
National Aeronautics and Space Admin.
Lyndon B. Johnson Space Center
Houston, Texas 77058

Dear John,

This letter constitutes the fifth monthly report on the renewal of NASA contract NAS9-14249.

One of the most interesting outputs from this recent renewal of the NASA contract has been a finding which originally came about by chance. As you know, the monkeys are maintained in isolation chambers at a constant temperature of $28 \pm 1^\circ\text{C}$. throughout the course of the experiments. However, we occasionally have equipment failure and we have noticed that on certain occasions, if a chamber temperature suddenly drops to approximately 20°C . or lower that there can be a considerable reduction in squirrel monkeys body temperature. However, on many occasions, the squirrel monkeys thermo-regulate very well and are able to maintain body temperature.

A further investigation of this phenomenon by Dr. Charles Fuller has indicated that monkeys who are synchronized by circadian light-dark cycles do not show temperature drops. However, monkeys who are free-running in constant light show an inability to cope with the same drop in chamber temperature. It does not matter at what phase of the circadian cycle cold pulse is applied and this phenomenon appears to develop after about seven days in constant light. We have been most interested in the possibility that two functions involving thermo-regulation could be desynchronizing from one to another so that thermoregulation might not occur so efficiently, and are investigating this possibility.

This finding is most interesting since the possibility of letting animals or even human subjects in long term space flight run at their own free-running rhythms has sometimes been considered and it has been claimed that the free-running state may be more "beneficial" than the synchronized state with a 24 hr cycle (which no longer has relevance in long term space flight). This finding should be pursued further because it may indicate that the free-running state is not necessarily advantageous, and that proper physiological functioning is dependent on an external zeitgeber.

With best wishes,

Sincerely yours,

Martin C. Moore Ede, M.B., B.S., Ph.D.
Assistant Professor of Physiology

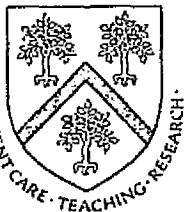

A Teaching Hospital
of the
Harvard Medical
School

HARVARD MEDICAL SCHOOL
DEPARTMENT OF PHYSIOLOGY



25 Shattuck Street
Boston, Mass. 02115
734-3300, Area Code 617

March 1, 1976

Dr. John A. Rummel, Ph.D.
Chief, Environmental Physiology Branch
National Aeronautics & Space Administration
Lyndon B. Johnson Space Center
Houston, Texas 77058

Dear John,

This letter constitutes the first monthly report on the second renewal of NASA contract NAS9-14249.

We have been proceeding rapidly with one of the primary aims of the second renewal of the contract - the study of the effect of light intensity on circadian internal synchronization. One type of internal desynchronization is that where different components of the same rhythmic variable separate and demonstrate different free-running periods and therefore constantly changing phase-relationships. This phenomenon has been recognized as being related to bright light intensities for the rhythm of activity. However, our data is now showing that a similar splitting phenomenon occurs in body temperature rhythms and in rhythms of urinary potassium excretion. The nature of the splitting appears to be an individual feature of each monitored variable and does not necessarily show up in all variables monitored simultaneously. Thus, it does not appear to be due to two central oscillators which split, but rather individual oscillators in the body, individually responsible for certain rhythmic functions which themselves are composed of populations of oscillators with the potentiality of splitting.

As you know, we have identified several serious consequences of the splitting phenomenon, which are important because the correct temporal relationships between physiological events is lost in such a situation. Probably one of the most drastic circumstances was mentioned briefly in last month's report. We have found that animals are unable to thermoregulate effectively against a drop in an environmental temperature when they are free-running in LL where as they can do it very effectively when they are synchronized to an LD cycle. Increasing evidence is now being gathered that underlying this failure of temperature regulation is a splitting of normally independent components of thermoregulation and the loss of normal phase-relationships between them compromises the abilities of the animal to homeostatically regulate against a cold pulse.

With best wishes,

Sincerely yours,

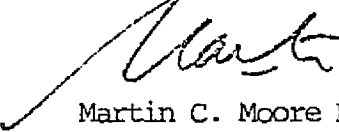
Martin C. Moore Ede, M.B., B.S., Ph.D.
Assistant Professor of Physiology

cc: Mr. A.F. Lee
Mr. G. Huff

MCME/msc

HARVARD MEDICAL SCHOOL
DEPARTMENT OF PHYSIOLOGY



25 Shattuck Street
Boston, Mass. 02115
734-3300, Area Code 617

April 1, 1976

Dr. John A. Rummel, Ph.D.
Chief, Environmental Physiology Branch
National Aeronautics & Space Administration
Lyndon B. Johnson Space Center
Houston, Texas 77058

Dear John,

This letter constitutes the second monthly report on the second renewal of NASA contract NAS9-14249.

This month we have investigated the differences between the control of circadian rhythms in adrenalectomized animals and in intact controls. Of particular interest has been the influence of the adrenal medullary hormones and the role of these in the circadian rhythm of body temperature. This, in particular has been studied in adrenalectomized animals with the adrenal cortical hormones of aldosterone and cortisol replaced but with no replacement of medullary hormones.

The circadian rhythm of body temperature in both these circumstances remains synchronized to the light-dark cycle. The mean level, amplitude, contour and other characteristics of the rhythm are indistinguishable between adrenalectomized monkeys and intact monkeys. Similarly, in LL in isolation the characteristics of the body temperature rhythms are very similar. However, one difference has been noted and this is the tendency for a damping to occur in the body temperature rhythm in adrenalectomized animals as compared to intact controls which is now being seen in several adrenalectomized monkeys. There appears to be no change in period, but on occasion, a major loss of amplitude can be observed. The mechanisms of these changes are currently under investigation.

With best wishes,

Sincerely yours,

Martin C. Moore Ede, M.B., B.S., Ph.D.
Assistant Professor of Physiology

MCME/msc

cc: Mr. A.F. Lee
Mr. G. Huff

Episodic 24-Hour Cortisol Secretory Patterns in Patients Awaiting Elective Cardiac Surgery

CHARLES A. CZEISLER,¹ MARTIN C. MOORE EDE,² QUENTIN R. REGESTEIN,³
ELDAD S. KISCH,⁴ VICTOR S. FANG,⁵ AND EDWARD N. EHRLICH⁶

Department of Biochemistry and Molecular Biology, Harvard College;¹ Departments of Surgery,² Psychiatry,³ and Endocrinology,⁴ Harvard Medical School at the Peter Bent Brigham Hospital; Department of Physiology,² Harvard Medical School; and the Endocrinology Laboratories, Department of Medicine,^{5,6} University of Chicago, Pritzker School of Medicine, Chicago, Illinois

ABSTRACT. The 24-hour pattern of plasma cortisol concentration in four patients on the day before major elective surgery was compared with that of five similarly hospitalized control subjects to study the effect of the expectation of surgery on the secretion pattern. Using an indwelling venous catheter, which extended outside the patient's room, to collect blood samples every 20 minutes for 24 hours, it was found that cortisol was secreted episodically in both control subjects and presurgical patients. The nycthemeral patterns of plasma cortisol concentration in the two groups were indistinguishable for most of the day despite the occurrence of intermittent events which appeared to cause anxiety in the presurgical patients. However, between 9 PM and 11 PM, while each presurgical patient was being preoperatively prepared (body shaving, wash, and enema), a major pulse of cortisol secretion occurred, raising the

plasma cortisol concentration to between 6.9–10.5 standard deviations above that of the control subject mean for that time of day.

We conclude that 1) expectation of a major surgical procedure for several weeks does not result in chronic activation of the pituitary-adrenocortical axis, 2) many discrete anxiety-provoking events do not evoke cortisol secretory episodes, 3) most episodes of cortisol secretion are part of an endogenous cyclical pattern with a circadian distribution and are not a direct result of environmental stimuli, and 4) preoperative preparation evokes a major cortisol secretory response in patients awaiting surgery. Whether that release of cortisol is a response to the physical manipulations or the psychological implications of that stimulus is presently unknown. (*J Clin Endocrinol Metab* 42: 273, 1976)

ANXIETY, and particularly the apprehension of personal injury, is generally considered to be a potent stimulus to ACTH and cortisol secretion (1–5). Yet attempts to correlate elevations in either plasma cortisol concentration or urinary 17-hydroxycorticosteroid excretion with psychologically stressful situations (both contrived and real) have often failed to demonstrate a consistent relationship in man (6–13). Such variability in the cortisol secretory response to a given situation among and within individuals has been explained in several ways. When

falling plasma cortisol concentrations have been observed in the face of apparent stress some investigators have concluded that the psychoendocrine response was being masked by a concurrent diurnal fall of plasma cortisol concentration (12,13). Other authors have suggested that personality type was the overriding factor in cortisol output (14–16) or that increased cortisol secretion was only seen when an individual's psychological defenses were inadequate to cope with a situation (7,8,10,17).

While such explanations may yet prove to be valid, another reason for the lack of a consistent correlation between anxiety-provoking situations and elevated plasma cortisol concentrations has become apparent from the demonstration by Weitzman and colleagues that cortisol is secreted episodically in man (18,19). Their use of frequent (20 minute) plasma sampling has demonstrated that cortisol secretion is limited to

Received May 9, 1975.

¹ Correspondence: Charles A. Czeisler, Department of Psychiatry, Stanford Medical School, Stanford, California 94305

Supported in part by National Aeronautics and Space Administration Contract NAS9-14249, by National Institutes of Health Grant HL-13872-16, by the Block Fund of the University of Chicago, and by the Fisher Endocrine Research Fund.

short pulses with no obvious secretion between those pulses (20,21), although the average nycthemeral pattern of cortisol concentration still demonstrates the previously reported circadian variation (22-24). This episodic 24-hour pattern of cortisol secretion explains why attempts to show a precise correlation between infrequently monitored plasma cortisol concentrations and psychologically stressful situations have had little success. Accurate definition of any psychoendocrine response which is superimposed upon a complex, pulsatile secretory cycle is simply not possible when only a few blood samples are taken on each day of study.

One naturally occurring situation which is associated with anxiety is the prospect of major surgery (25). Patients awaiting elective cardiac surgery were chosen for this study since most such patients feel that the operation poses a significant threat which they consent to undertake in the hope of a successful relief of their symptoms. Consequently, such patients might be expected to demonstrate a major adrenocortical response (1,2). This paper reports a study which compared the 24-hour patterns of plasma cortisol concentration measured at 20 minute intervals in four patients during the 24-hour period just prior to undergoing open-heart surgery with the 24-hour cortisol patterns of five control subjects who were similarly hospitalized.

Materials and Methods

Control subjects. Five healthy, normal male subjects (A,B,C,D, and E), 21-43 years of age (mean = 26.3 years), were studied in the Clinical Research Center of the Peter Bent Brigham Hospital. Each subject was a personal acquaintance of one of the authors (C.C). Normality was established by clinical history, physical examination, and routine clinical biochemical screening. Signed informed consent was obtained from each subject.

Each subject received several hours of instruction prior to the investigation in order to minimize the possible effects of uncertainty about the experimental procedures (11). For at least

one week prior to the study, each subject kept a daily record of their estimated times of sleep onset and waking. A clinical psychiatrist (Q.R.), interviewed each subject for one to three hours. Without prior knowledge of the endocrine data, he ranked each subject according to manifest display of emotional responses on a scale from the overt expression of emotionality to a tendency towards inhibition of emotional responses. This was done in conformity with studies using similar clinical methods (15,26). On that scale (overt expression to inhibition) the subjects ranked in the following order: A,D,E,B,C.

The subjects were admitted to the Clinical Research Center on the day prior to the study in order to foster adjustment to the hospital environment. They were provided a normal diet containing 100 mEq potassium and 150 mEq sodium per 24 hours. The subjects were restricted to light activity or bedrest during the adaptation and experimental days. Lights were switched out at 11 PM and switched on at 7 AM daily (L:D 16:8).

Venipuncture was performed on each of the control subjects three days prior to the study in order to reacquaint them with that procedure (27). In order that the reported adrenocortical secretory response to intravenous catheterization (28) would not confound the results of the control studies, such catheterization was performed at least 12 hours before the 24-hour blood sampling procedure was begun. A sterile teflon catheter was inserted into a forearm vein and connected to a 12-foot-long section of polyethylene tubing (1.14 mm ID) which extended out into the hall adjacent to the subject's room. The tubing was insulated with translucent tubing of a larger diameter, to prevent the subject from sensing temperature changes as blood was drawn through the line. This intravenous line was kept patent with a microdrip infusion of heparinized saline (500 U sodium heparin and 0.45 g NaCl per 100 ml) at a rate of 12 ml/h. Frequent blood samples could thus be obtained from outside the subject's room without his being aware of the procedure (19). Blood samples (1.5 ml) were withdrawn from the extended indwelling catheter every 20 minutes, starting at 7 AM on the day after admission to the hospital and continuing for the subsequent 25 hour period. The subjects reported that they slept normally throughout the period of darkness (11 PM-7 AM).

The degree of anxiety or apprehension was subjectively assessed using a 1-5 rating scale (13,29), at twenty minute intervals, throughout the period of the experiment. In addition, a detailed log was kept of events which occurred during the day of the experiment.

Presurgical patients. Four patients age 36-59 (mean = 44 years) were studied during the 24-hour period immediately prior to elective coronary artery bypass graft surgery. Three patients were men (W, Y and Z) and one was a woman (X). They had slept 3 to 8 nights in the hospital just prior to their studies. Except for a previous history of myocardial infarction, in X, Y, and Z, and significant occlusion of one or more coronary arteries, determined by coronary angiography in all cases, each patient had no other medical abnormalities. No patient had any endocrine or metabolic disorder, and, specifically, there was no evidence of congestive heart failure, hypertension, hyper- or hypothyroidism, Cushing's or Addison's disease, or recurrent angina pectoris although all reported the experience of angina pain on strenuous physical exertion. No episodes of angina occurred at any time during these studies. One of the patients (Y) had undergone the same operation one year before. None of the patients were receiving any medication with the following exceptions: all were given sodium methicillin (Staphcillin, 1 g) prophylactically at midnight; Y received isosorbide dinitrate (Isordil Tembids, 80 mg/day); W, X, and Y consented to forego the usual preoperative sleep medication, but Z received glutethimide (Doriden, 0.5 g), a non-barbiturate hypnotic, at midnight.

All of the patients before cardiac surgery in this study were intellectually aware of the risks of major cardiac surgery. They each talked about their fears of the operation repeatedly during the day of study and described themselves as anxious.

Blood sampling from outside of the patient's room was accomplished at 20 minute intervals through an indwelling catheter as described above for the control subjects, from 6 AM on the day before surgery until 7 AM on the day of surgery. For the patient's comfort, the catheter was not placed until just prior to sampling. During the day of the study the patients engaged in light activity or bedrest similar to that of the normal volunteers. The degree of anxiety and apprehension was estimated as described for the

normal subjects, and a log was kept with particular attention paid to the timing of potentially stressful events during the day—such as diagnostic procedures, venipuncture, etc.

Plasma cortisol assay. After each blood sample had been collected in a heparinized tube it was centrifuged and the plasma aliquot frozen for subsequent biochemical assay. The cortisol concentration in each of the 670 plasma samples drawn in the study was assayed in duplicate using the competitive protein binding technique in a modification of the method of Murphy (30) after Rosenfield *et al.* (31). The inter-assay coefficient of variation was 7%.

Presentation of data. An average time of sleep onset for each subject was calculated from his record of the seven nights prior to the study. This was used as the zero point of the time scale for plotting his cortisol data. This time of reported mean sleep onset (MSO) for the previous week was chosen as a common reference point rather than the actual time of "lights out" on the night of the experiment because the circadian cortisol secretory pattern has been shown to persist with unaltered phase for several days after a phaseshift of the light-dark or sleep-wake cycles (32,33). The actual clock times of sleep onset and waking on the experimental days are shown in Figs. 1 and 3 by downward and upward arrows respectively.

For purposes of statistical analysis, the 24-hour sleep-wake cycle was divided into the following 4 phases: Phase I = 4 hours before until 2 hours after MSO, Phase II = 2 to 4 hours after MSO, Phase III = 4 to 9 hours after MSO, and Phase IV = 15 to 4 hours before MSO. These divisions are similar to those outlined by Weitzman *et al.* (19), as were the criteria for defining secretory episodes. Comparisons of the cortisol data between the two experimental groups were made using Student's *t* test, and linear regression analysis was used to test for correlations between anxiety ratings and cortisol concentration.

Results

Control subjects. The patterns of plasma cortisol concentration for the 24-hour study period in the five normal subjects are plotted in Fig. 1. The mean plasma cortisol concentration, range of values, number of secretory

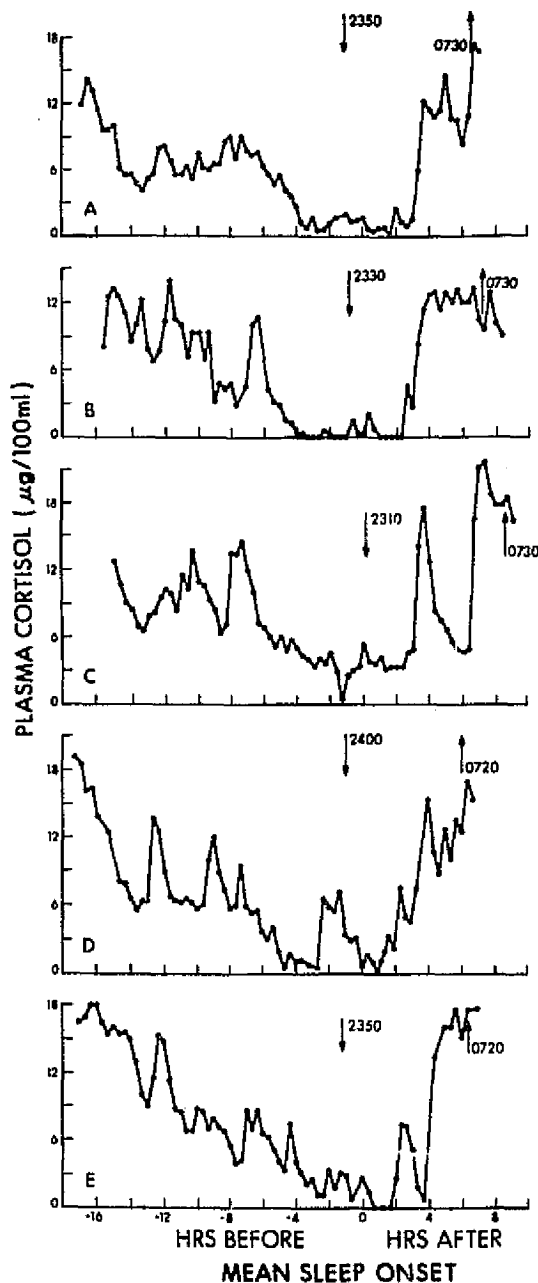

FIG. 1. 24-hour plasma cortisol concentration patterns in five control subjects. Time of mean sleep onset during the preceding week is shown as zero hours on the time scale. The actual time of lights out and lights on of the experimental day are shown by downward and upward arrows, respectively, along with the clock (EDT) time at those points.

episodes, and longest period when the cortisol concentration did not rise above the mean are presented in Table 1. In each subject the concentration of cortisol fluctuated widely during the day in a manner suggesting discrete episodes of cortisol secretion. In the period from 4 hours before to 2 hours after mean sleep onset (MSO) there were no secretory pulses which rose above the 24-hour mean level in the normal subjects. This dormant period regularly ended between 2 and 3 hours after MSO, with the initiation of a series of major secretory pulses which continued throughout the remainder of the sleep period. Maximum concentrations were reached about 7 hours after MSO. A fall in plasma cortisol concentrations was then seen in 4 out of the 5 subjects during the morning (16 to 13 hours before MSO). During the middle of the day, several secretory pulses were observed in each subject; none of these reached the values observed during the late sleep period. Day-time ratings of anxiety in these control subjects rarely rose above 2 on a scale of 1, low, to 5, high. No incidents occurred which produced significant affective response; even mild apprehension about events in the environment was rare. The plasma concentration of cortisol was not significantly correlated with anxiety ratings in the twenty minutes immediately before blood sampling in the control subjects ($P > .05$). There was also no significant rank-order correlation between the mean plasma cortisol concentration (Table 1) and the psychiatric rating of these subjects on the scale of manifest display of emotional responses.

Figure 2 shows the mean pattern of plasma cortisol concentration in the 5 normal subjects. The circadian variation is readily apparent (at the expense of obscuring the pulsatile nature of the secretion) with a maximum plasma cortisol concentration of $16.9 \pm 3.9 \mu\text{g}/100 \text{ ml}$ (mean \pm SD) at 7 hours after MSO and a minimum level of

TABLE 1. Analysis of plasma cortisol patterns over a full 24-hour period

Subjects		Mean cortisol concentration ($\mu\text{g}/100\text{ ml}$)	Minimum cortisol concentration ($\mu\text{g}/100\text{ ml}$)	Maximum cortisol concentration ($\mu\text{g}/100\text{ ml}$)	No. of secretory episodes	Length of quiescent period (hours)
Control	A	6.1 ± 4.2	0.2	17.3	7	9.0
	B	6.3 ± 4.9	0.0	13.9	7	8.9
	C	8.3 ± 4.9	0.4	21.5	5	9.3
	D	7.2 ± 4.8	0.0	18.6	7	9.0
	E	8.1 ± 5.8	0.0	18.0	7	9.7
	Mean	7.2 ± 1.0	0.1 ± 0.2	17.9 ± 2.7	6.6 ± 0.9	9.2 ± 0.3
Presurgical	W	9.6 ± 4.7	2.1	20.5	7	7.3
	X	9.8 ± 4.4	4.6	27.2	7	4.7
	Y*	7.9	3.1	16.0	7	4.7
	Z	7.9 ± 3.4	0.0	16.8	8	3.3
	Mean	8.8 ± 1.0	2.5 ± 2.3	20.1 ± 5.1	7.3 ± 0.5	5.0 ± 1.7
P value		NS	<.05	NS	NS	<.001

* Samples could not be collected for three hours (from 3 to 6 hours after MSO) in subject Y; his values in this table are therefore based on the remaining 61 determinations.

NS = not significant ($P > .05$).

$1.0 \pm 1.8 \mu\text{g}/100\text{ ml}$ at 1 hour after MSO. Thus, although cortisol was secreted episodically, the average pattern of this group of individuals demonstrated a circadian rhythm.

Presurgical patients. The patterns of plasma cortisol concentration in the four preoperative cardiac surgery patients are shown in Fig. 3. Superimposed on each individual pattern is the mean pattern ($\pm\text{SD}$) of the normal subjects (from Fig. 2). For most of the day the patterns of plasma cortisol concentration in the preoperative patients were very similar to those seen in the normal subjects, with a similar number of secretory episodes (Table 1). However, in Phase I, coincident with preoperative preparation (consisting of a complete chest, abdomen, and leg shaving, antiseptic wash, and enema—indicated in Fig. 3 by a black bar with an "E" at the time of the enema) each patient had a major episode of cortisol secretion. Plasma cortisol concentration reached values that were between 6.9 and 10.5 standard deviations above the mean level for the control subjects at the corre-

sponding time of day. The mean concentration for the presurgical patients during Phase I ($7.1 \mu\text{g}/100\text{ ml}$) was 3.7 times higher ($P < .001$) than that of the normal subjects ($1.9 \mu\text{g}/100\text{ ml}$) (Table 2). The difference in Phase I maximum concentrations between the two groups (16.4 vs $4.0 \mu\text{g}/100\text{ ml}$) was also highly significant ($P < .001$), as was the difference between the two groups in the length of the dormant period ($P < .001$) (Table 1).

The elevations in plasma cortisol concentration coincident with preoperative preparation appeared to represent a discrete pulse of cortisol secretion followed by a period of several hours with no further cortisol secretory pulses while the plasma concentration fell. The secretory pulse associated with preoperative preparation occurred during the period of the day when cortisol secretion was at a minimum in the control subjects.

It is difficult to separate out the influence of the different components of the presurgical preparation. For example, in one patient (W), the cortisol secretory episode associated with preoperative preparation

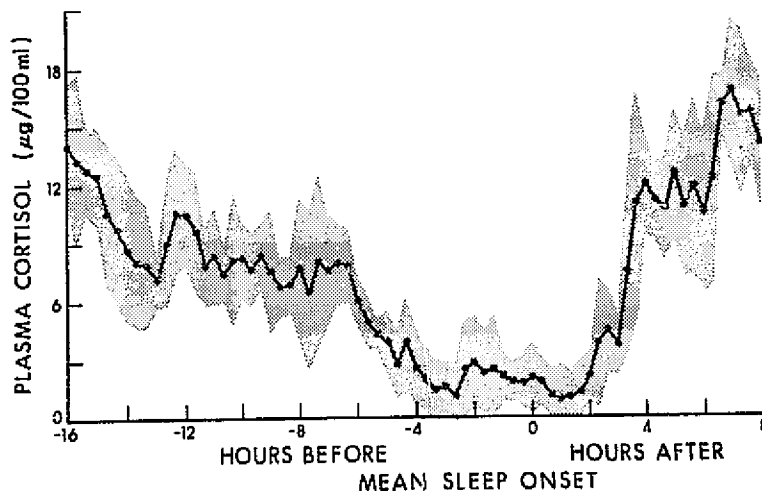

FIG. 2. Mean and standard deviation of plasma cortisol concentration at 20-minute intervals for a 24-hour period in five control subjects.

preceded the enema, whereas in the other patients the enema either just preceded, or was coincident with the pulse of secretion. While a secretory episode always began during the period of preparation, no single component of that preoperative preparation (shaving, enema, or antiseptic wash) showed a consistent temporal relationship with the timing of the secretory response.

Another major pulse of cortisol secretion appeared to be associated in patient X with the preoperative teaching procedure (shown by a "T" in Fig. 3) in which the patient was instructed about the intensive care situation in which she would awaken after the operation. However, patients W and Z also experienced a similar preoperative teaching procedure and no major pulse of cortisol secretion immediately followed in either case, although patient W, who had that experience earlier in the day, did have a minor pulse afterward. Patient Y received no preoperative teaching because he had previously undergone the same operation a year earlier. It is interesting to note that he had the smallest peak of cortisol secretion in response to the preoperative shaving procedure.

Other pulses of cortisol secretion which occurred during the day could not be related consistently to potentially stressful events. For example, the insertion or rein-

sertion of an intravenous catheter (for this study or for laboratory tests which were performed on the patients—indicated in the Figures by the letters "IV") was occasionally, but not consistently, followed by a pulse of cortisol secretion, but such pulses were unremarkable since cortisol concentration in those cases never rose above 2 standard deviations from the control subject mean. Similarly, times of high anxiety ratings could sometimes, but not consistently, be related to secretory episodes and no significant correlation could be detected between anxiety rating and plasma cortisol concentration ($P > .05$). Secretory episodes of similar magnitude and timing often occurred in both the control subjects and the presurgical patients with no apparent psychogenic stimulus. In fact, inspection of the patterns either visually (Figs. 1 and 3) or by phase statistics (Table 2) shows that the patterns of the presurgical patients were indistinguishable from those of the controls at all times except during preoperative preparation.

Discussion

The twenty-minute sampling procedure revealed an episodic 24-hour cortisol secretory pattern in both the control subjects and the presurgical patients. The 24-hour patterns in the control subjects were consistent

with previously published patterns of frequent plasma cortisol measurements in normal subjects (18-20, 34, 35).

The pattern of plasma cortisol concentration in the presurgical patients remained within the limits established for the normal controls for most of the preoperative day. This was in spite of, a) the mean age differences which existed between the two groups, b) the fact that those in the control group were personal acquaintances of one of the authors, whereas the presurgical patients were not, c) differences in the time of catheter placement between the two groups, d) the few medications noted in the methods section that were taken by the presurgical patients but not the control subjects, and e) most importantly, the many incidents during the presurgical studies which provoked overt and often verbal expressions of apprehension and anxiety relating to the patient's upcoming surgery. Furthermore, these patients who had been facing the threat of the operation for some weeks did not have the kind of psychoendocrine activation of the adrenocortical axis which Sachar *et al.* have demonstrated in depressed patients (29). The presurgical patients neither had markedly elevated plasma cortisol concentrations throughout the day nor an increased number of daily secretory episodes (Table 1). This suggests that neither the discrete emotional stresses associated with the immediate presurgical situation nor the longer-term anticipation of upcoming surgery re-

sulted in hyperactivation of the hypothalamic-pituitary-adrenocortical axis. Most episodes of secretion that were observed in both the normal subjects and the presurgical patients could not be reliably correlated with environmental stimuli.

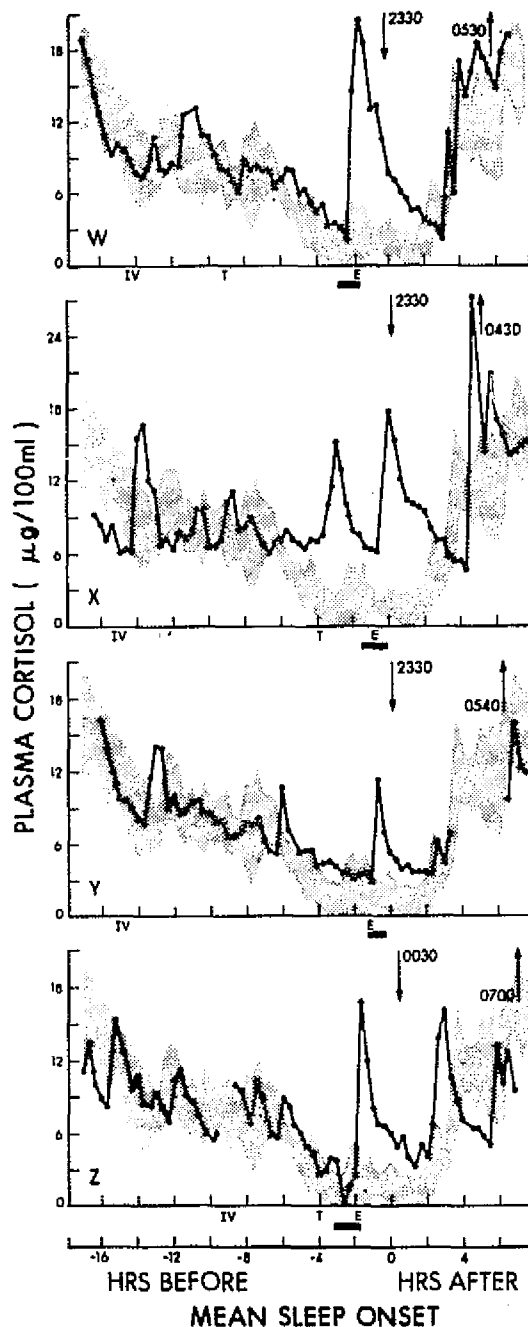

FIG. 3. 24-hour plasma cortisol concentration patterns in four patients on the day prior to elective coronary artery bypass graft surgery superimposed over the mean pattern (\pm SD) from the control subjects (of Fig. 2). Time of mean sleep onset is used as the common time reference, as in Fig. 1; the times of lights out and waking are also similarly indicated. Symbols beneath each graph indicate the time when certain events occurred: "IV"—insertion of an intra-venous catheter; "T"—preoperative teaching, which involved instruction designed to acquaint patients with what they should expect after surgery. The time of presurgical preparation is indicated by a horizontal bar, with the letter "E" specifically denoting the time of the preoperative enema.

TABLE 2. Analysis of cortisol concentration ($\mu\text{g}/100\text{ ml}$) during each phase of the 24-hour cycle

Subject	Phase I (-4 to 2)*			Phase II (2 to 4)*			Phase III (4 to 9)*			Phase IV (-15 to -4)*		
	Mean \pm SD	Min	Max	Mean \pm SD	Min	Max	Mean \pm SD	Min	Max	Mean \pm SD	Min	Max
Control												
A	1.2 \pm 0.6	0.2	2.5	5.6 \pm 5.2	1.0	12.3	11.9 \pm 2.6	8.5	17.3	6.1 \pm 1.5	2.6	9.0
B	0.3 \pm 0.6	0.0	2.1	6.6 \pm 5.0	0.0	12.7	11.6 \pm 1.6	8.4	13.3	7.0 \pm 3.6	0.3	13.9
C	3.5 \pm 1.0	0.4	5.3	9.5 \pm 6.0	3.2	17.4	12.4 \pm 6.6	4.5	21.5	8.9 \pm 2.7	4.7	14.6
D	2.7 \pm 2.3	0.0	7.2	9.1 \pm 4.5	4.7	15.4	13.6 \pm 2.8	9.1	18.6	6.4 \pm 3.1	0.4	13.7
E	1.6 \pm 1.1	0.0	3.1	5.0 \pm 3.1	0.8	13.3	16.4 \pm 1.4	13.3	18.0	8.5 \pm 3.6	3.2	15.5
Mean	1.9 \pm 1.3	0.1	4.0	7.2 \pm 2.0	1.9	14.2	13.2 \pm 2.0	8.6	17.7	7.4 \pm 1.3	2.2	13.3
Pre-surgical												
W	8.1 \pm 5.6	2.1	20.5	7.1 \pm 5.7	2.1	16.8	15.0 \pm 3.2	9.3	19.0	8.3 \pm 2.0	4.5	13.1
X	10.3 \pm 3.3	6.2	17.6	6.4 \pm 1.1	5.2	7.9	13.9 \pm 6.3	4.6	27.2	8.2 \pm 2.5	5.9	16.6
Y†	4.5 \pm 1.9	3.1	11.3	(7.7)			(11.5)			8.1 \pm 2.3	4.3	14.1
Z	5.4 \pm 3.9	0.0	16.8	10.5 \pm 3.8	6.6	16.1	9.9 \pm 3.2	5.4	15.4	7.9 \pm 2.1	2.6	12.7
Mean	7.1 \pm 2.3	2.9	16.6	7.9 \pm 1.8	4.6	13.6	12.6 \pm 2.3	6.4	20.5	8.1 \pm 0.2	4.3	14.1
P value	<.001	<.05	<.001	NS	NS	NS	NS	NS	NS	NS	NS	NS

* Hours before and after mean sleep onset (MSO).

NS = not significant ($P > .05$).

† See footnote about missing samples for "Y" in Table 1.

These findings thus support the concept that even during the waking period, the episodic pattern of plasma cortisol concentration is part of an endogenous cyclical functioning of the pituitary-adrenocortical axis rather than a series of responses to intermittent environmental stimuli (19).

In contrast, there was a single event during the late evening that was consistently related to a major pulse of cortisol secretion in the presurgical patients. Preoperative preparation, which consisted of complete chest, abdomen, and leg shaving, antiseptic wash, and an enema, induced a major pulse of cortisol secretion which raised the cortisol concentration between 6.9 and 10.5 standard deviations above the control subject mean values for that time of day. This response of the pituitary-adrenocortical axis occurred at whatever time in the evening each patient was preoperatively prepared. It therefore appears to have been induced by either the psychological or physiological components of that complex stimulus, since none of the differences between the two subject groups which were noted in the preceding paragraph could account for such a temporally related change in cortisol secretion.

It is possible that on the evening before open-heart surgery, body shaving could provoke the acute focusing of diffuse and unconscious anxieties about an approaching surgical procedure, thus seriously challenging and perhaps temporarily overwhelming a patient's psychological defenses by confronting him with the reality and the immediacy of his forthcoming operation. This explanation would be consistent with previous observations on the parents of fatally-ill children during an acute challenge to psychological defenses (8). Alternatively, the preoperative preparation could act as a physiological stimulus since considerable non-specific sensory stimulation was involved although previous work has suggested that other late evening sensory stimuli do not always result in an increase in cortisol secretion (36). In either event, it would appear that while the normal pattern of episodic cortisol secretion is generated by an endogenous mechanism, additional secretory episodes can be specifically induced by episodes of stress.

The present study has shown that secretory episodes induced by environmental events during periods of normally minimal cortisol secretion can result in considerable

disruption of the normal circadian distribution of plasma cortisol pulses. This finding may provide an explanation for the occurrence of circadian rhythm internal desynchronization in monkeys subjected to various stressors (37), and human subjects with a high neuroticism index who are placed in isolation (38). Moore Ede (39) has recently demonstrated that the circadian rhythm of plasma cortisol concentration plays an essential role in synchronizing circadian rhythms of electrolyte metabolism with the circadian rest-activity cycle. When the plasma cortisol circadian rhythm is eliminated by the continuous infusion of replacement corticosteroids in adrenalectomized human or animal subjects, circadian rhythms such as renal potassium excretion become desynchronized from the rest-activity cycle, and oscillate with their own free-running period. Environmentally-induced stresses which cause the circadian distribution of secretory episodes to approach a continuous series of secretory episodes thus might cause the loss of the synchronizing cue normally provided by the plasma cortisol circadian rhythm. In this situation, those circadian oscillations in physiological variables which are normally synchronized by the plasma cortisol rhythm would begin to free-run, while other variables with circadian rhythms which are not dependent on the plasma cortisol rhythm would remain normally synchronized with environmental time cues. This postulated mechanism for the initiation of circadian internal desynchronization clearly requires further experimental testing, but it is possible that this may be an important process in the pathophysiology of stress.

Another important conclusion from the present study is that frequent blood sampling for at least 24 hours must be used to define the influence of environmental variables on the pituitary-adrenal axis. The late evening pulses of secretion demonstrated herein would probably have been overlooked if samples had been taken infrequently or over limited periods of time. This explains why earlier studies of plasma

cortisol concentration measured once or twice daily in presurgical patients (40-42) yielded inconsistent results. In the present study, the 8 AM mean cortisol concentration in our four preoperative patients was 11.6 $\mu\text{g}/100\text{ ml}$ (range 8.4 to 16.2), whereas the 8 AM mean of the normal volunteers was 14.0 $\mu\text{g}/100\text{ ml}$ (range 10.5 to 18.0)—statistics which fail to reflect the consistent differences which did exist between the two groups at a later time of day. Similarly, the 24-hour mean plasma cortisol levels did not indicate the differences between the two groups. Furthermore, it is clear that adequate analysis of the results of such frequent blood sampling must include statistical comparisons with a true control group at corresponding times of day; failure to do so adequately in an earlier study of multiply-sampled presurgical patients by Wise *et al.* led them to overlook the consistent and significant changes demonstrated in our study, which also, in retrospect, appear to have occurred in their patients before surgery (43).

In summary, in this study it has been possible to clarify the influence of environmental stimuli on the 24-hour secretion pattern of plasma cortisol by using the multiple frequent blood sampling technique. We have shown that the circadian pattern of plasma cortisol concentration consists of a sequence of episodic pulses which are normally unrelated to specific environmental stimuli, even in a situation in which there were many anxiety provoking events. However, major secretory pulses can reliably be superimposed on the endogenous cyclical pattern by certain acute environmental stimuli, such as preoperative surgical preparation.

Acknowledgments

The authors wish to thank Doctors James C. Orr, Norman I. Gold, Gordon H. Williams, and Francis D. Moore for their support and encouragement of this work. We are grateful to Doctors Toma Hoeksema and Luke Pascale for their permission and aid in the study of their patients. We also wish to express special thanks to Ms. Margaret R. Ball and Ms. Farida Siddiqui for their technical advice and help in the

laboratory and to Ms. Susan Ruane for her assistance in compiling the manuscript. We are indebted to the subjects who volunteered for these studies, and to the staffs of the Saint Francis Hospital in Chicago and the Peter Bent Brigham Hospital in Boston for their consistent cooperation.

References

- Hamburg, D. A., Plasma and urinary corticosteroid levels in naturally occurring psychologic stresses, *Res Publ Assoc Res Nerv Ment Dis* 40: 406, 1962.
- Mason, J. W., A review of the psychoendocrine research on the pituitary-adrenal cortical system, *Psychosom Med* 30: 576, 1968.
- Williams, R. H., Textbook of Endocrinology, ed. 5, W. B. Saunders, Philadelphia, 1974, p. 249.
- Donovan, B. T., Mammalian Neuroendocrinology, McGraw-Hill, London, 1970, p. 65.
- Canong, W. F., Review of Medical Physiology, ed. 6, Lange Medical Publications, Los Altos, California, 1973, p. 282.
- Bourne, P. G., R. M. Rose, and J. W. Mason, Urinary 17-OHCS levels: Data on seven helicopter ambulance medics in combat, *Arch Gen Psychiatry* 17: 104, 1967.
- Bourne, P. G., R. M. Rose, and J. W. Mason, 17-OHCS levels in combat, *Arch Gen Psychiatry* 19: 135, 1968.
- Friedman, S. B., J. W. Mason, and D. A. Hamburg, Urinary 17-hydroxycorticosteroid levels in parents of children with neoplastic disease, *Psychosom Med* 25: 364, 1963.
- Mason, J. W., E. J. Sachar, J. R. Fishman, D. A. Hamburg, and J. H. Handlon, Corticosteroid responses to hospital admission, *Arch Gen Psychiatry* 13: 1, 1965.
- Katz, J. L., H. Weirer, T. F. Gallagher, and L. Hellman, Stress, distress and ego defenses: Psychoendocrine response to impending breast tumor biopsy, *Arch Gen Psychiatry* 23: 131, 1970.
- Wadson, R. W., J. W. Mason, D. A. Hamburg, and J. H. Handlon, Plasma and urinary 17-OHCS responses to motion pictures, *Arch Gen Psychiatry* 9: 146, 1963.
- Bliss, E. L., C. J. Migeon, C. H. H. Branch, and L. T. Samuels, Reaction of the adrenal cortex to emotional stress, *Psychosom Med* 18: 56, 1956.
- Persky, H., R. R. Grinker, D. A. Hamburg, M. A. Sabshin, S. J. Korchin, H. Basowitz, and J. A. Chevalier, Adrenal cortical function in anxious human subjects, *Arch Neurol Psychiatry* 76: 549, 1956.
- Fiorica, V., and S. Muehl, Relationship between plasma levels of 17-OHCS and a psychological measure of manifest anxiety, *Psychosom Med* 24: 596, 1962.
- Fox, H. M., S. Gifford, A. F. Valenstein, and B. J. Murawski, Psychophysiological correlation of 17-ketosteroids and 17-hydroxycorticosteroids in 21 pairs of monozygotic twins, *J Psychosom Res* 14: 71, 1970.
- Bloch, S., and C. J. Brackenridge, Psychological, performance and biochemical factors in medical students under examination stress, *J Psychosom Res* 16: 25, 1972.
- Wolff, C. T., S. B. Friedman, M. A. Hofer, and J. W. Mason, Relationship between psychological defenses and mean urinary 17-hydroxycorticosteroid excretion rates: I. A predictive study of parents of fatally ill children, *Psychosom Med* 26: 576, 1964.
- Weitzman, E. D., H. Schaumburg, and W. Fishbein, Plasma 17-hydroxycorticosteroid levels during sleep in man, *J Clin Endocrinol Metab* 26: 121, 1966.
- Weitzman, E. D., D. Fukushima, C. Nogueira, H. Roffwarg, T. F. Gallagher, and L. Hellman, Twenty-four hour pattern of the episodic secretion of cortisol in normal subjects, *J Clin Endocrinol Metab* 33: 14, 1971.
- Hellman, L., F. Nakada, J. Curti, E. D. Weitzman, J. Kream, H. Roffwarg, S. Ellman, D. K. Fukushima, and T. F. Gallagher, Cortisol is secreted episodically in normal man, *J Clin Endocrinol Metab* 30: 411, 1970.
- Gallagher, T. F., K. Yoshida, H. D. Roffwarg, D. K. Fukushima, E. D. Weitzman, and L. Hellman, ACTH and cortisol secretory patterns in man, *J Clin Endocrinol Metab* 36: 1058, 1973.
- Mills, J. N., Human circadian rhythms, *Physiol Rev* 46: 128, 1966.
- Nichols, C. T., and F. H. Tyler, Diurnal variation in adrenal cortical function, *Annu Rev Med* 18: 313, 1967.
- Perkoff, G. T., K. Eik-Nes, C. A. Nugent, H. L. Fred, R. A. Nimer, L. Rush, L. T. Samuels, and F. H. Tyler, Studies of the diurnal variation of plasma 17-hydroxycorticosteroids, *J Clin Endocrinol Metab* 19: 432, 1959.
- Bodley, P. O., H. V. R. Jones and M. D. Mather, Preoperation anxiety: A qualitative analysis, *J Neurol Neurosurg Psychiatry* 37: 230, 1974.
- Fox, H. M., B. J. Murawski, A. F. Bartholomay, and S. Gifford, Adrenal steroid excretion patterns in eighteen healthy subjects: Tentative correlations with personality structure, *Psychosom Med* 23: 33, 1961.
- Davis, J., R. Morrill, J. Fawcett, V. Upton, P. K. Bondy and H. M. Spiro, Apprehension and elevated serum cortisol levels, *J Psychosom Res* 6: 83, 1962.
- Rose, R. M., and M. W. Hurst, Plasma cortisol and growth hormone responses to intravenous catheterization, *J Human Stress* 1: 22, 1975.
- Sachar, E. J., L. Hellman, H. P. Roffwarg, F. S. Halpern, D. K. Fukushima, and T. F. Gallagher, Disrupted 24-hour patterns of cortisol secretion

- in psychotic depression, *Arch Gen Psychiatry* 28: 19, 1973.
30. Murphy, B. E. P., Some studies of the protein-binding of steroids and their application to the routine micro and ultramicro measurement of various steroids in body fluids by competitive protein-binding radioassay, *J Clin Endocrinol Metab* 27: 973, 1967.
 31. Rosenfield, R. L., W. R. Eberlein, and A. M. Bongiovanni, Measurement of plasma testosterone by means of competitive protein binding analysis, *J Clin Endocrinol Metab* 29: 854, 1969.
 32. Orth, D. N., D. P. Island, and G. W. Fiddle, Experimental alteration of the circadian rhythm in plasma cortisol (17-OHCS) concentration in man, *J Clin Endocrinol Metab* 27: 549, 1967.
 33. Weitzman, E. D., D. G. Kripke, J. Kream, P. McGregor, and L. Hellman, The effect of a prolonged non-geographic 180 degree sleep-wake shift on body temperature, plasma growth hormone and cortisol and urinary 17-OHCS, *Psychophysiology* 7: 307, 1970.
 34. deLacerda, L., A. Kowarski, and C. J. Migeon, Integrated concentration and diurnal variation of plasma cortisol, *J Clin Endocrinol Metab* 36: 227, 1973.
 35. Krieger, D. T., W. Allen, F. Rizzo, and H. P. Krieger, Characterization of the normal temporal pattern of plasma corticosteroid levels, *J Clin Endocrinol Metab* 32: 266, 1971.
 36. Ismail, A. A. A., D. W. Davidson, J. A. Loraine, and C. A. Fox, Relationship between plasma cortisol and human sexual activity, *Nature* 237: 288, 1972.
 37. Stroebel, C. F., Biologic rhythm correlates of disturbed behavior in the rhesus monkey, *Bibl Primate* 9: 91, 1969.
 38. Lund, R., Personality factors and the desynchronization of circadian rhythms, *Psychosom Med* 36: 224, 1974.
 39. Moore Ede, M. C., Control of Circadian Oscillations in Renal Potassium Excretion in the Squirrel Monkey, Ph.D. Thesis, Harvard University, 1974.
 40. Franksson, C., and C. A. Gemzell, Adrenocortical activity in the preoperative period, *J Clin Endocrinol Metab* 15: 1069, 1955.
 41. Price, D. B., M. Thaler, and J. W. Mason, Preoperative emotional states and adrenal cortical activity: Studies on cardiac and pulmonary surgery patients, *Arch Neurol Psychiatry* 77: 646, 1957.
 42. Bursten, B., and J. J. Russ, Preoperative psychological state and corticosteroid levels of surgical patients, *Psychosom Med* 27: 309, 1965.
 43. Wise, L., H. W. Margraf and W. F. Ballinger, A new concept on the pre- and postoperative regulation of cortisol secretion, *Surgery* 72: 290, 1972.

TRANSIENT CIRCADIAN INTERNAL DESYNCHRONIZATION
AFTER LIGHT-DARK PHASESHIFT IN SQUIRREL MONKEYS

Martin C. Moore-Ede

David A. Kass

J. Alan Herd

Department of Physiology, Harvard Medical School, Boston, MA 02115; Department of Surgery, Harvard Medical School at the Peter Bent Brigham Hospital, Boston, MA 02115; and Department of Psychiatry, Harvard Medical School at the New England Regional Primate Research Center, Southboro, MA 01772.

Running Title: CIRCADIAN INTERNAL DESYNCHRONIZATION

Correspondence To: Dr. M.C. Moore-Ede, Department of Physiology, Harvard Medical School, 25 Shattuck Street, Boston, MA 02115.

ABSTRACT

The response of the circadian rhythms of feeding, drinking, activity, body temperature, and urinary potassium, sodium and water excretion to manipulations of environmental time cues were studied in four conscious chair-acclimatized squirrel monkeys (Saimiri sciureus). With lights on (600 lux) from 08.00-20.00 hr and off from 20.00-08.00 hr daily (LD 12:12), prominent circadian rhythms in each of these variables were seen, with maxima in each case during the lights-on period. When the light-dark cycle was manipulated to provide 36 hours of darkness followed by 36 hours of light each circadian rhythm persisted with an approximately 24-hour period, and thus was demonstrated not to be passively dependent on the light-dark cycle. When the light-dark cycle was abruptly phase-delayed by 8 hours so that light-on thereafter occurred between 16.00 and 04.00 hrs, all the monitored circadian rhythms resynchronized with the new light-dark cycle phase, demonstrating that light-dark cycles are an effective zeitgeber. However, the rate of resynchronization differed between variables so that the resynchronization of the rhythms of feeding, drinking, activity and body temperature was 90% complete within approximately 2 days while the 90% resynchronization of the circadian rhythms of urinary potassium, sodium and water excretion took approximately 5 days. These results suggest that the circadian timing system in Saimiri sciureus may consist of several spontaneously oscillating units which become transiently uncoupled during perturbations of environmental time cues.

INDEX TERMS: circadian rhythms, transient internal desynchronization, squirrel monkey, light-dark cycle, zeitgeber phaseshift.

Endogenous circadian oscillations in physiological variables have been demonstrated in organisms ranging from unicellular algae (13) to man (8). There is now considerable evidence to suggest that these physiological rhythms are generated by self-sustained oscillators within the organism (20, 21). These circadian oscillators are normally synchronized by environmental time cues, such as the light-dark cycle, but in the absence of such cues, the oscillating system demonstrates free-running periods which are usually different from 24 hours.

Any conclusion as to the organization and physiology of these circadian oscillators must be compatible with an important phenomenon known as "internal synchronization." It has been demonstrated in both unicellular (19) and multicellular (2,3,6,11) organisms that when circadian rhythms in several physiological variables are monitored simultaneously in an individual animal they are usually found to have identical periods. This has been observed whether the organism is synchronized by environmental time cues or has its circadian rhythms free-running under constant conditions. Such internal synchronization either demands that within an organism there must be only one oscillator or "clock" upon which all endogenous circadian rhythms are passively dependent, or, if there is more than one oscillator, then the various oscillators must be normally synchronized with one another.

This paper reports studies in which we have manipulated environmental time cues to determine the extent of the coupling between seven behavioral and physiological variables which show circadian rhythmicity in the squirrel monkey. If constant internal phase relationships were maintained between the various circadian rhythms throughout these perturbations then this would suggest that all the rhythms were passively dependent on a single

ORIGINAL PAGE IS
OF POOR QUALITY

circadian oscillator. On the other hand if certain oscillating functions responded more rapidly than others to perturbations in environmental time cues, so that transient circadian internal desynchronization was observed, then this would suggest the possibility that the circadian timing system in the squirrel monkey is composed of multiple potentially-independent oscillators.

MATERIALS AND METHODS

The studies were performed using four adult male squirrel monkeys (Saimiri sciureus) weighing 600-900 gms. For periods of up to three weeks, continuous urine collections were obtained from unanesthetized monkeys, conditioned to sit in a specially designed metabolism chair. Environmental illumination, temperature and auditory stimuli were controlled by conducting experiments within an isolation chamber. Once the monkeys were conditioned, they tolerated studies lasting two to three weeks, and showed no ill effects or loss of agility upon return to their cages. While in the metabolism chair they behaved normally and maintained body weight.

Metabolism Chair. The design of this chair was based upon the squirrel monkey chairs used in the behavioral experiments of Kelleher and Morse (16). The monkey sat on a bar and was restrained by a plexiglass sheet which served as a table around its waist. The space between the table and the monkey was sealed by a soft rubber waist cuff. The monkey had freedom of movement about the waist. Below the plexiglass table, it could either squat with its feet on a footrest or sit on the perch.

A lever was provided which the animal could operate to obtain food pellets. Pellets were delivered into a tray directly in front of the animal from a pellet dispenser (Model 11-1, Gerbrands Co., Arlington, Massachusetts). Drinking water was provided from a calibrated water bottle.

A padded funnel, placed between the monkey's legs, enabled the collection of urine samples uncontaminated by feces and food debris. Urine passed from the funnel into test tubes within a specially designed automatic fraction collector. The apparatus which contained slots for 24 test tubes (100 x 15 mm) was rotated every two hours by a stepping motor (Ledex 24-step Digimotor, Ledex, Inc., Dayton, Ohio). The fraction collector was covered by a sheet of plexiglass which both prevented particles from falling into the test tubes and served as a foot rest for the monkey.

Isolation Chamber. The monkey, chair and fraction collector were housed in a temperature-controlled isolation chamber (Forma Scientific, Models 12 or 20, Marietta, Ohio). The chamber temperature was monitored by a continuously recording thermometer (Bacharach Instrument Co., Pittsburgh, Pennsylvania). To provide ventilation, the fan on the heating-cooling unit was used to provide a circulation with air from outside the chamber.

A light source within the chamber, yielding approximately 600 lux of white light, was switched on each day in control studies from 08.00-20.00 hr and off from 20.00-08.00 hr. When the light was off there was less than 1 lux of illumination in the chamber. The animals were thus subjected to a 24-hour light-dark cycle (LD 12:12; 600:<1).

The isolation chambers partially attenuated extraneous sounds and a white noise source was used in addition to provide further muffling. The white noise was generated by a Grason-Stadler Noise Generator (Model 901-B, West Concord, Massachusetts). Activities outside the chamber had no discernable effects on the animal's behavior.

Experimental Control and Recording Systems. The timing and control of the experimental system were accomplished by an automatic switchboard. One section

of the switchboard was controlled by a clock which operated switches in electrical circuits every two hours thus activating the stepping motor of the fraction collector, the timing record on the continuous paper recorders, and the counter and switch which controlled the illumination cycle of the isolation chamber. Another part of the switchboard controlled the food pellet delivery to the monkey. The number of lever operations to gain a pellet was controlled by a counter and the time between pellet deliveries was controlled by an adjustable timer.

Feeding, drinking and movements in the chair were recorded from each monkey continuously using Harvard C-3 cumulative and 6-pen recorders (Gerbrands, Arlington, Massachusetts). Physical activity was monitored by an ultrasound motion detector (Alton Electronics Co., Gainesville, Florida). Drinking from the water bottle was detected by closure of an electrical circuit between the perch, the monkey and the water bottle spout. The volume of water consumed each day was determined by measuring the fluid level according to calibrations on the water bottle. The drinking water contained less than 1 mEq/L of sodium or potassium and hence contributed insignificantly to the dietary intake of these electrolytes.

Food pellet lever responses and food pellets obtained were also recorded. Electrical pulses were generated from the automatic switchboard by the food lever countdown devices and these were used to activate the recorders. An additional cumulative counter was used to record the total pellets obtained. The 24-hour food intake could be read from this counter. By adjusting the number of responses required to gain a pellet it was possible to ensure that the monkey would eat all of the food pellets delivered.

Body Temperature. Continuous recordings were made of core body temperature using thermistors built in the laboratory. Prior to implantation, the thermistors were each calibrated by measuring the resistance across a Wheatstone Bridge while the thermistor was immersed in a water filled vacuum bottle at various temperatures. An M.B.S. specification total immersion centigrade thermometer was used to determine the calibration temperatures. The thermistors were implanted using a sterile operative procedure. Anesthesia was induced and maintained with Halothane (2-bromo, 2-chloro, 1,1,1-trifluoroethane, Fluothane) in oxygen. A left paramedial incision was made and the left retroperitoneal space was exposed by blunt dissection. Thermistors, sterilized by soaking in Zephiran (benzal-konium chloride) solution, were implanted in the retroperitoneal space. The thermistor was tied in place with nylon sutures through the abdominal wall muscles and the thermistor leads were brought out to reach the skin surface between the animal's shoulder blades. The external leads were protected by placing a nylon mesh jacket on the monkey which otherwise allowed the animal freedom of movement. During experiments, body temperature was recorded by connecting a cable to the thermistor leads. The cable was led out of the isolation chamber and connected as one arm of a Wheatstone Bridge. The bridge output was amplified and recorded on a Grass Instrument Co. (Quincy, Massachusetts) Polygraph Model #7. The Grass paper record was calibrated using the previously determined calibration graph. The thermistors underwent no detectable drift in calibration or sensitivity change over the course of the experiments, and this was confirmed by repeat calibrations up to four months later.

Light-Dark Cycle Disruption. A two day period of acclimatization to the metabolism chair and isolation conditions was allowed before each experiment.

Four monkeys were then studied during a control day with lights off from 20.00-08.00 hr and lights on from 08.00-20.00 hr (LD 12:12). They were then subjected to 36 hours of continuous darkness followed by 36 hours of continuous light. During the four days of the experiment, urine collections and recordings of feeding and activity and drinking were made as described above. Food and water were available ad lib throughout both light and dark conditions during this study.

8-Hour Light-Dark Cycle Phaseshift. After a two day acclimatization period, four monkeys were studied for two control days with lights on between 08.00 and 20.00 hr daily. The animals were then subjected to an 8 hour phase-delay of the light-dark cycle by adding 8 hour of light to the end of the second control day. Thereafter, lights were on from 16.00 hr to 04.00 hr daily. During the experiment, the monkeys were allowed to feed and drink ad lib. Care was taken to open the isolation chamber only during the monkey's self-selected activity and feeding periods. Continuous recordings were made of activity, feeding, drinking, body temperature and urinary excretion rates as described above.

Urine Analyses. After the urine samples were removed from the fraction collector they were acidified with two drops of 25% sulfuric acid and refrigerated at 4°C. The volume of urine in each tube was measured, and sodium and potassium concentrations were analyzed by flame photometry (Instrumentation Laboratories, Lexington, Massachusetts). Urine excretion rates ($\mu\text{Eq/hr}$) were then calculated for each electrolyte from the volume of each sample, the concentration of the electrolyte and the length of time over which the sample was collected.

Data Processing. The urinary data was first expressed as a smoothed three-point running mean. This was done by averaging the excretory rate during each two-hourly period with the excretory rates of the two neighboring two-hourly collections. This procedure reduced the influence of the monkey's irregularly timed micturitions on the excretory pattern without significantly affecting the amplitude of any circadian periodicity in the data.

In order to define the phases of the rhythms in urinary excretion, the data was expressed as a percentage deviation from a running 24 hour mean. This 24 hour mean was calculated from the excretory values for 12 hours on either side of each data point. In order to do this urine was collected for 12 extra hours at the beginning and end of each experimental run. The phase of the oscillation was defined in terms of the two clock times (E.D.T.), at which it passed upwards and downwards through the running 24 hour mean on each cycle (i.e., the zero crossings). A similar computation was undertaken to determine the phase of the circadian rhythm in body temperature, while the phases of the circadian rhythms of activity, feeding and drinking were computed from the daily clock times of commencement and termination of each behavioral activity. This process of phase determination was repeated for each variable for each cycle throughout the experiment. Phaseshifts were then computed by comparing the clock time (in hours) of the rhythm zero crossings on each experimental day with the mean clock time of the equivalent zero crossings during the control days of the experiment. Computations were performed using a Hewlett-Packard 2116B computer.

RESULTS

Response to Perturbation of the Light-Dark Cycle.

Figure 1 presents the mean (\pm SEM) results from four monkeys exposed to the light-dark schedule of 36 hours of continuous darkness followed by 36 hours of continuous light. On the control day before the disrupted light-dark cycle, the monkeys demonstrated their normal circadian rhythms of activity, feeding, drinking and urinary potassium, sodium and water excretion. All movements in the chair, feeding and drinking were confined to the lights-on segment of the 24 hour cycle although food and water were continuously available throughout day and night. Urinary potassium excretion fell to a minimum of 66.5 ± 26.2 μ Eq/hr at 07.00 hr and then rose to a maximum of 203.0 ± 58.1 μ Eq/hr at 19.00 hr. Urinary sodium excretion similarly showed a circadian rhythm with a minimum of 24.0 ± 19.1 μ Eq/hr at 09.00 hr and a maximum of 41.2 ± 24.8 μ Eq/hr at 19.00 hr. Urinary water excretion fell to a minimum of 787.4 ± 223.0 μ L/hr between 05.00 and 07.00 hr and then rose to a maximum of 1849.9 ± 408.0 μ L/hr at 13.00 hr.

During the 36 hours of constant darkness the circadian rhythms of activity, feeding, drinking, urinary potassium, sodium and water excretion all persisted despite the absence of the 12 hour light period during the second day of the experiment. Movements in the chair, feeding and drinking were again virtually restricted to the 12 hours between 08.00 and 20.00 hr although the monkeys were in the dark and isolated from other environmental time cues. The amplitudes of all these behavioral rhythms however, were reduced during the period of constant darkness. In contrast, the circadian rhythms of urinary potassium, sodium and water excretion persisted with unchanged amplitudes.

When the animals were subjected to the 36 hours of constant light during days 3 and 4, the circadian rhythms of the behavioral and urinary variables again continued with little change in pattern. When the lights were left on overnight between 20.00 and 08.00 hr on day 4, there was a small amount of additional activity, feeding and drinking at the beginning and again at the end of the "night". However, most activity, feeding and drinking was confined to the "day" period between 08.00 and 20.00 hr. The circadian rhythms of urinary potassium and water excretion continued with an unchanged amplitude but that of urinary sodium excretion was reduced in amplitude on the last day of constant light.

Response to 8-Hour Light-Dark Cycle Phase-Delay.

A representative response of a monkey to the 8-hour phase-delay of the light-dark cycle is shown in Figure 2. Similar responses were seen in all four monkeys studied. During the two control days, the monkey confined movements in the chair, feeding and drinking to the light-on period of the 24 hours. The body temperature of the monkey demonstrated a prominent circadian rhythm with an amplitude of more than 2°C. Body temperature fell to a nocturnal minimum at approximately 06.00 hr and started to rise each day before the lights switched on, and then reached a plateau level at which it remained throughout most of the light-on period. Body temperature then fell at the time of lights-off. Urinary potassium excretion fell to a nocturnal minimum at 05.00 hr and rose to a daily maximum at 17.00 hr as in the previous experiment. Urinary sodium excretion fell to a minimum at 03.00-07.00 hr and reached a maximum at 19.00 hr, and urinary water excretion fell to a minimum at 07.00 hr and rose to a maximum at 19.00 hr.

After the light-dark cycle phaseshift the circadian rhythms of activity, feeding and drinking rapidly readjusted to the new light-on phase of the 24 hour cycle. The rhythm of body temperature on the first day after the light-dark cycle phaseshift started rising at 08.00 hr although the lights had not come on and the monkey had not yet started its activity, feeding and drinking. The temperature rose by approximately 1.6°C and then fell back towards the nocturnal level before rising finally when the lights did come on at 16.00 hr. The body temperature from 16.00 to 20.00 hr remained at a plateau similar to the control day temperature. Then although the lights were not switched off at 20.00 hr, as they were during the two previous days, body temperature started to fall towards the nocturnal level. This phenomenon was seen in each of the four monkeys studied during the light-dark cycle phaseshift. The circadian rhythm of body temperature gradually adjusted to the new light-dark cycle over the next several days. The circadian rhythms of urinary potassium, sodium and water excretion also began to adjust to the new light-dark cycle phase but this process occurred more slowly.

The phaseshifts of each of the monitored physiological variables were quantified using the "zero crossing" procedure described in the Methods Section. The results for the four animals are presented in Figure 3. Each circadian rhythm resynchronized with the new phase of the light-dark cycle. However, a transient internal desynchronization was seen with certain rhythms phaseshifting more rapidly than the others.

An exponential function $\Delta\phi = -Ae^{-kt} - C$, where $\Delta\phi$ = the phaseshift in hours and t = the time after the LD phaseshift in hours, was fitted to the phaseshift data for each variable using an iterative non-linear least-squares regression program based on the Marquardt algorithm¹. The value for the fitted parameters

A, k and C for each physiological variable, together with the time for the variable to achieve 90% of the light-dark cycle (8 hour) phaseshift are given in Table I. While the phaseshifts of the circadian rhythms of activity, feeding, drinking and body temperature were 90% complete within approximately two days (51.2 hours) after the light-dark phaseshift, it took 110.5 - 132.9 hours for the circadian rhythms of urinary potassium, sodium and water excretion to phase-shift by the same distance. Covariance analysis indicated that the rhythms of the urinary variables took significantly longer to phaseshift ($p < .05$) than the behavioral and body temperature rhythms. There was no significant difference between the individual rates of phaseshift in the different urinary variables, nor between the rates of phaseshift among the non-urinary rhythms.

Table II presents the calculated periods of each of the circadian rhythms at intervals after the light-dark phaseshift, computed from the instantaneous slopes of the fitted exponential functions for each variable. In order to achieve a phase delay, each rhythm must transiently show an increase in period. This table demonstrates that the periods of each of these rhythms, although all 24.0 hours before and after the phaseshift, show different periods during the phaseshift because they shift at different rates. They are, therefore, transiently internally desynchronized.

DISCUSSION

The squirrel monkey was demonstrated to have prominent circadian rhythms in activity, feeding, drinking, body temperature, and urinary potassium, sodium and water excretion which were normally synchronized with the environmental light-dark cycle. The circadian rhythms in these variables were not passively dependent on the light-dark cycle since they persisted with an approximately 24-hour period when the animals were subjected to 36 hours of constant darkness, followed by 36 hours of constant light. However, when the environmental light-dark cycle was shifted to a new phase which was maintained for at least eight days, all the monitored rhythms eventually resynchronized, achieving the same phase-relationships with the new light-dark cycle. This confirmed the earlier reports of Richter (22) who suggested that the dominant circadian zeitgeber (environmental time cue) for the squirrel monkey was the light-dark cycle.

The purpose of the current study was to determine whether changes in the internal phase-relationships between circadian rhythms in different variables in the same animal could be induced by zeitgeber manipulations. It was found in the squirrel monkey that this could be achieved when the animals were subjected to an abrupt phaseshift of the light-dark cycle. The circadian rhythms of activity, feeding, drinking and body temperature resynchronized by 90% of the light-dark cycle phaseshift within approximately two days. However, the circadian rhythm of renal potassium, sodium and water excretion took approximately five days to undergo the same 90% phaseshift. There was some suggestion that the circadian rhythm of activity phaseshifted more rapidly than all other variables, however because of variability in the rates of phaseshift between individual animals this difference was not found to be statistically significant

by covariance analysis.

The term internal desynchronization is used to describe a state where different oscillating variables, which normally have identical periods and constant phase-relationships within an animal (i.e., are internally synchronized), demonstrate different periods and therefore constantly changing phase-relationships (4,25,26). The calculation of the period of each monitored circadian rhythm at 24 hourly intervals after the light-dark cycle phaseshift in the current studies (Table II) demonstrated that the various rhythms had different periods at each instant of time during the resynchronization process. However, once all the circadian rhythms had resynchronized with the light-dark cycle after approximately seven days, then they all demonstrated an identical period (24.0 hours) and their original constant internal phase-relationships. Because the internal desynchronization that was observed between the rhythmic variables in the current experiments was observed temporarily between two stable synchronized states, it should be referred to as transient internal desynchronization. In contrast, the term steady state internal desynchronization is restricted to a situation where two or more rhythmic variables are shown to complete internal phase-angle shifts of at least 360° with respect to one another (25,26).

The transient internal desynchronization that was seen between the urinary circadian rhythms and the other circadian rhythmic variables in the current experiments suggests that the circadian timing system in the squirrel monkey may be composed of more than one potentially-independent oscillating unit. After an abrupt change in the phase of the dominant zeitgeber, the various oscillators appeared to become transiently uncoupled. Transient internal desynchronization after environmental zeitgeber phaseshifts also appear to occur in rodents (14,15) and humans (5,8-10,17,18), although the data is harder to interpret. In

rodents, the time course of the phaseshifts of different rhythmic variables cannot be determined in an individual animal because the rhythms have been determined by sacrificing groups of animals for each data point. In human subjects, studies of zeitgeber phaseshifts are complicated by the ability of man to willfully phaseshift his activity, feeding and other behavioral functions with respect to environmental time cues. Thus, the influence of zeitgeber phaseshifts cannot be easily separated from the effects induced by simultaneous consciously-imposed phaseshifts in behavioral patterns. In the present studies, however, we have been able to examine in the squirrel monkey the phaseshifts of multiple variables simultaneously in individual animals in response to the manipulation of only one zeitgeber.

The internal phase-angle shifts which occur during resynchronization with a new light-dark cycle phase cannot be taken as conclusive proof that the circadian timing system is composed of multiple oscillating units. It is possible that there is a single oscillator and that there are major delays in the transmission of phase information to the various tissues which show passive circadian rhythmicity. Such a mechanism, however, would require improbable delays, for the phaseshift of the urinary circadian rhythms was not complete until 72 hours after complete external resynchronization of the other monitored rhythms had occurred. An alternative interpretation would invoke a scheme where a single self-sustained oscillator could be driving a set of damped oscillators which were not themselves capable of generating self-sustained oscillations. The inertia possessed by these damped oscillators could be sufficient to account for the transient internal phase-angle shifts that were seen during resynchronization with the light-dark cycle. These alternative models have been made untenable however, at least in man, by the demonstration of steady-state internal

desynchronization by Aschoff, Wever and co-workers (2-4,25,26). They have shown that more persistent internal desynchronization lasting several weeks occasionally occurs in human subjects isolated in a chamber from all external time cues. In these experiments, circadian rhythms in different physiological variables have been seen to oscillate with independent stable periods so that during the course of an experiment the different variables may cycle past each other and thereby show internal phase-angle shifts of more than 360° . A multiple oscillator system that is capable of uncoupling must be invoked to explain this observation.

In contrast, the evidence from Gonyaulux, a unicellular organism, suggests that it possesses only one circadian "clock". McMurray and Hastings (19) have shown that four different circadian rhythms of cellular function (photosynthetic capacity, glow, cell division and luminescence capacity) continued to have constant phase interrelationships during a variety of experimental manipulations, including a phaseshift induced by abrupt alterations of environmental illumination. If we can generalize from Gonyaulux, unicellular organisms would appear to have a single circadian oscillator, while higher multicellular organisms may have multiple circadian oscillators. Such a conclusion is supported by recent reports that mammalian organs, or even cell suspensions maintained in constant culture conditions in vitro, can continue to show persisting circadian or ultradian oscillations (1,7,12,23,24). Presumably, each isolated tissue in these studies contains one or more self-sustained circadian oscillators which, although normally coupled with the other tissue oscillators within the organism, can oscillate independently when the coupling mechanism is strained or destroyed.

The evidence from the literature suggesting that the circadian timing system in higher animals may consist of an organization of coupled oscillators provides a useful basis for a search for oscillator locations and their coupling mechanisms.

The present studies demonstrate that the renal electrolyte circadian rhythms in the squirrel monkey can be transiently phase-delayed from the other monitored circadian rhythms when the animal is submitted to an abrupt phaseshift of the light-dark cycle. Because these urinary rhythms arise from an organ, the kidney, with an anatomically discrete location and with well defined neural and endocrine communications with other body functions, these studies suggest an opportunity to investigate the physiological nature of the coupling link which maintains the internal synchronization of the renal electrolyte rhythms with other circadian oscillations within the animal.

TEXT FOOTNOTES

1. Page 10. Library Program BMDP3R of the Health Sciences Computing Facility, University of California, Los Angeles.

ACKNOWLEDGEMENTS

The authors are grateful for the support and encouragement of Dr. A.C. Barger and Dr. F.D. Moore and for discussions with Dr. Frank Sulzman and Dr. Charles Fuller. We also wish to thank Mr. Jonathan Russo, Mr. Harvey Kaufman, Ms. Susan Grose, Ms. Lourdes Hojeko, Ms. Margaret Ball and Ms. Margaret Clukey.

This work was supported in part by National Aeronautics and Space Administration Contract NAS9-14249, and by National Institutes of Health Grant GN-22085 and SCOR Grant HL-14150. MOME was the recipient of a NATO Research Studentship during part of this work.

REFERENCES

1. Andrews, R.V., and Shiotsuka, R. In Vitro adrenal studies in relation to cyclic reproductive success. In: Biorhythms and Human Reproduction. edited by M. Ferin, F. Halberg, R. Richart, and R. Vande Wiele, New York: John Wiley and Sons, 591-603, 1974.
2. Aschoff, J. Circadian Rhythms in Man. Science 148: 1427-1432, 1965.
3. Aschoff, J. Desynchronization and Resynchronization of Human Circadian Rhythms. Aerosp Med 40: 844-849, 1969.
4. Aschoff, J., Gerecke, V. and Wever, R. Desynchronization of human circadian rhythms. Jap J Physiol 17: 450-457, 1967.
5. Aschoff, J., Hoffman, K., Pohl, H. and Wever, R. Re-entrainment of circadian rhythms after phase-shifts of the zeitgeber. Chronobiologia 2: 23-78, 1975.
6. Aschoff, J. and Pohl, H. Rhythmic variations in energy metabolism. Fed Proc 29: 1541-1552, 1970.
7. Ashkenazi, I. E., Hartman, H.H. Activity rhythms of enzymes in human red blood cells: 'in vitro' and 'in vivo' studies. Chronobiologia Suppl. 1, 5, 1975.
8. Conroy, R.T.W.L., and Mills, J.N. Human Circadian Rhythms. London: J and A Churchill, 1st edition, 1970.
9. Elliot, A.L., Mills, J.N., Minors, D.S. and Waterhouse, J.M. The effect of real and simulated time-zone shifts upon circadian rhythms of body temperature, plasma 11-hydroxycorticosteroids and renal excretion in human subjects. J Physiol (Lond) 221: 227-257, 1972.
10. Flink, E.B., and Doe, R.P. Effect of sudden time displacement by air travel on synchronization of adrenal function. Proc Soc Exp Biol Med 100: 498-501, 1959.

11. Gibbs, F.P. and Van Brunt, P. Correlation of plasma corticosterone ("B") levels with running activity in blinded rats. Fed Proc 34: 301, 1975.
12. Hardelund, R. Circadian rhythmicity in cultured liver cells. Int J Biochem 4: 581-590, 1973.
13. Hastings, J.W. and Sweeney, B.M. The Gonyaulux Clock. In: Photoperiodism in Plants and Animals, edited by R.B. Withrow, Washington, D.C.: American Association for Advancement of Science, 567-584, 1959.
14. Haus, E., and Halberg, F. Phase-shifting of circadian rhythm in rectal temperature, serum corticosterone and liver glycogen of the male C-mouse. Rass Neurol Veg 23: 83-171, 1969.
15. Huber, J. and Hamprecht, B. Tageszeitlicher Rhythmus der Hydroxymethylglutaryl-CoA-Reduktase in der Rattenleber. Hoppe-Seylers Z physiol Chem 353: 307-312, 1972.
16. Kelleher, R.T., and Morse, W.H. Escape behavior and punished behavior. Fed Proc 23: 808-817, 1964.
17. LaFontaine, E., Lavernhe, J., Courillon, J., Medvedeff, M. and Ghata, J. Influence of air travel east-west and vice versa on circadian rhythms of urinary elimination of potassium and 17-hydroxycorticosteroids. Aerosp Med 38: 944-947, 1967.
18. Martel, P.J., Sharp, G.W.G., Slorach, S.A., and Vipond, H.J. A study of the roles of adrenocortical steroids and glomerular filtration rate in the mechanism of the diurnal rhythm of water and electrolyte excretion. J. Endocrinol. 24: 159-169, 1962.
19. McMurray, L., and Hastings, J.W. No desynchronization among four circadian rhythms in the unicellular algae, Gonyaulux polyhedra. Science 175: 1137-1139, 1972.

20. Menaker, M. Aspects of the physiology of circadian rhythmicity in the vertebrate central nervous system. In: The Neurosciences, edited by F.O. Schmidt and F.G. Worden, Boston: M.I.T. Press, 479-489, 1973.
21. Pittendrigh, C.S. Circadian oscillations in cells and the circadian organization of multicellular systems. In: The Neurosciences, edited by F.O. Schmidt and F.G. Worden, Boston: M.I.T. Press, 435-458, 1973.
22. Richter, C.P. Inherent twenty-four hour and lunar clocks of a primate - the squirrel monkey. Comp Behav Bio, Part A 1: 305-332, 1968.
23. Shiotsuka, R., Jovonovich, J. and Jovonovich, J.A. In Vitro data on drug sensitivity: circadian and ultradian rhythms in adrenal organ cultures. In: Chronobiological Aspects of Endocrinology. edited by J. Aschoff, F. Ceresa, and F. Halberg, New York: Schattauer-Verlag, 255-267, 1974.
24. Tharp, G.D., and Folk, G.E., Jr. Rhythmic changes in rate of the mammalian heart and heart cells during prolonged isolation. Comp Biochem Physiol 14: 255-273, 1965.
25. Wever, R. Internal phase-angle differences of human circadian rhythms: causes for changes and problems of determinations. Int J Chronobiol 1: 371-390, 1973
26. Wever, R. The circadian multi-oscillator system of man. Int J Chronobiol 3: 19-55, 1975.

FIGURE LEGENDS

Figure 1 Circadian rhythms (mean \pm SEM) of activity, feeding, drinking and urinary potassium, sodium and water excretion in four squirrel monkeys. After two equibration days (not shown on the graph) with lights on from 08.00-20.00 hr daily, the animals were studied for a control day on the same light-dark cycle followed by a 36 hour period of constant darkness and then a 36 hour period of constant light. Despite the manipulations of the light-dark cycle each monitored circadian rhythm persisted with a period of approximately 24 hours.

Figure 2 The response of a representative monkey to an eight-hour phase-delay of the light-dark cycle. The circadian rhythms of activity, feeding, drinking, body temperature and urinary potassium, sodium and water excretion are plotted during two control days with lights on from 08.00-20.00 hr, and then for the first four days after the light-dark cycle phaseshift where lights were on from 16.00-04.00 hr daily. Each circadian rhythm gradually resynchronized with the new light-dark cycle phase.

Figure 3

Response of the circadian rhythms of activity, feeding, drinking, body temperature, and urinary potassium, sodium and water excretion in four squirrel monkeys to an eight-hour phase-delay of the light-dark cycle. The change in phase of the 'zero-crossing' markers on each cycle, as compared to the phase of the same markers during the control days, was plotted as a function of the time elapsed after the light-dark cycle phaseshift. An exponential function was fitted (as described in the text) to the phaseshift of the rhythm markers. The circadian rhythms of activity, feeding, drinking, and body temperature phaseshifted significantly ($p < .05$) more rapidly than the urinary rhythms to the new light-dark cycle phase.

Table I

Parameters of the function $\Delta\phi = -Ae^{-kt} - C$ fitted to the phaseshifts of the monitored circadian rhythms after an eight-hour phase-delay of the light-dark cycle, where $\Delta\phi$ is the phaseshift in hours, k is the time constant and C is the final steady state phaseshift of the variable in hours. Also given is the time for each variable, in hours, to complete 90% of the light-dark cycle phaseshift.

	A	k	C	t (hours) for 90% of LD $\Delta\phi$
Activity	-9.79	-0.411	7.41	9.3
Feeding	-5.31	-0.037	8.00	51.2
Drinking	-4.99	-0.046	8.00	39.8
Temperature	-6.29	-0.044	8.00	46.9
Urinary Potassium	-9.69	-0.023	7.88	115.5
Urinary Sodium	-9.38	-0.022	7.65	132.9
Urinary Water	-9.10	-0.027	7.66	110.5

Table II

Instantaneous periods of the monitored circadian rhythms at intervals during resynchronization with an eight-hour light dark phaseshift.

	<u>Hours After LD Phaseshift</u>									
	<u>0</u>	<u>12</u>	<u>24</u>	<u>48</u>	<u>72</u>	<u>96</u>	<u>120</u>	<u>144</u>	<u>168</u>	<u>192</u>
Activity	24.0	24.7	24.0	24.0	24.0	24.0	24.0	24.0	24.0	24.0
Feeding	24.0	27.0	25.9	24.8	24.3	24.1	24.1	24.0	24.0	24.0
Drinking	24.0	27.2	25.8	24.6	24.2	24.1	24.0	24.0	24.0	24.0
Body Temperature	24.0	27.9	26.3	24.3	24.1	24.0	24.0	24.0	24.0	24.0
Urinary Potassium	24.0	28.1	27.1	25.8	25.0	24.6	24.3	24.2	24.1	24.1
Urinary Sodium	24.0	27.4	26.6	25.5	24.9	24.5	24.3	24.2	24.1	24.1
Urinary Water	24.0	28.3	27.1	25.6	24.8	24.4	24.2	24.1	24.1	24.0

Fig 1

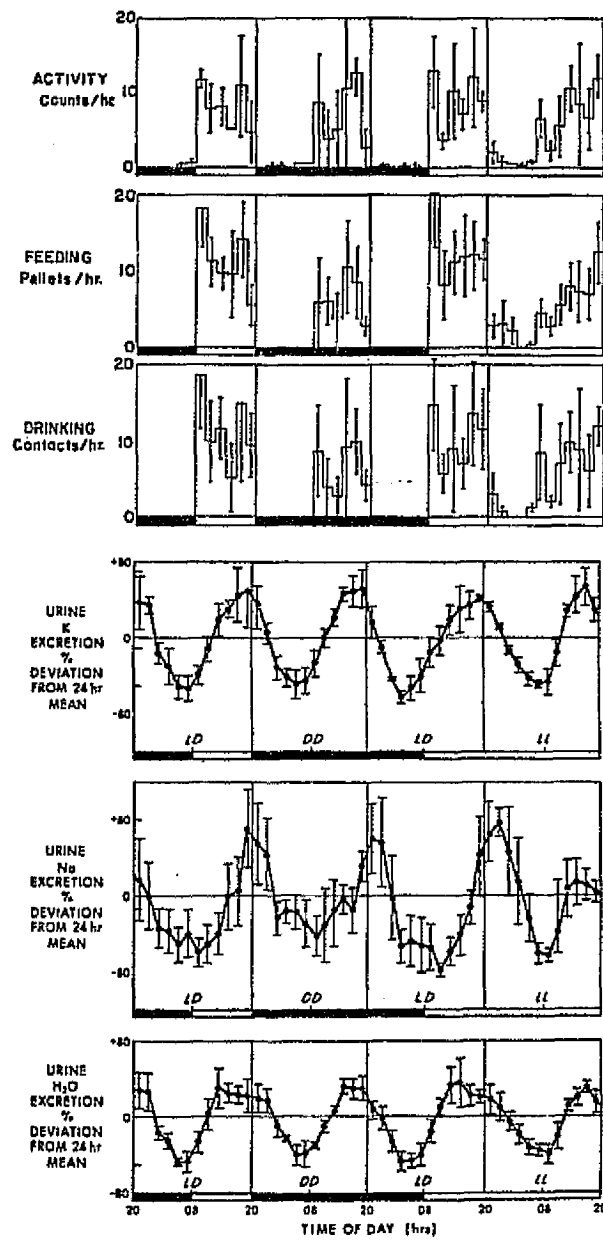

ORIGINAL PAGE IS
OF POOR QUALITY

PRECEDING PAGE BLANK NOT FILMED

Fig 2

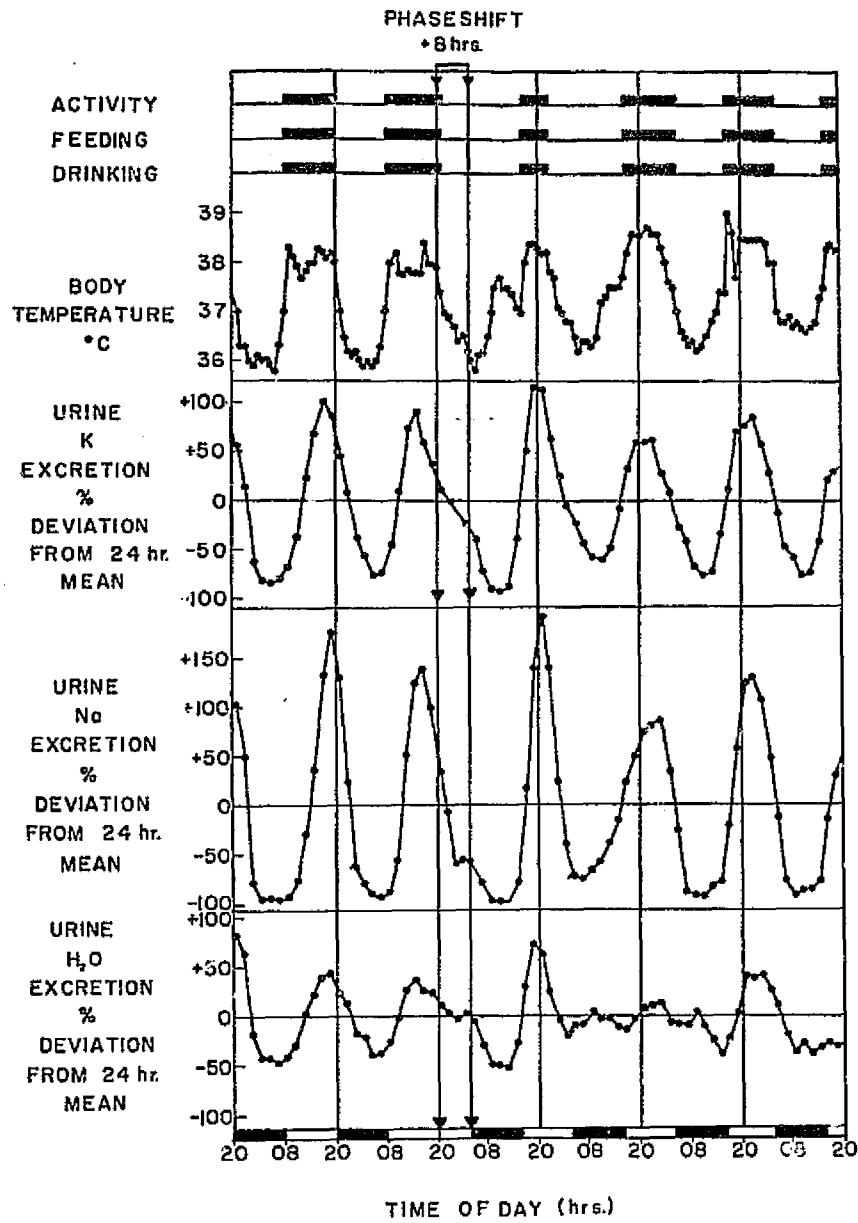

ORIGINAL PAGE IS
OF POOR QUALITY

Fig 3

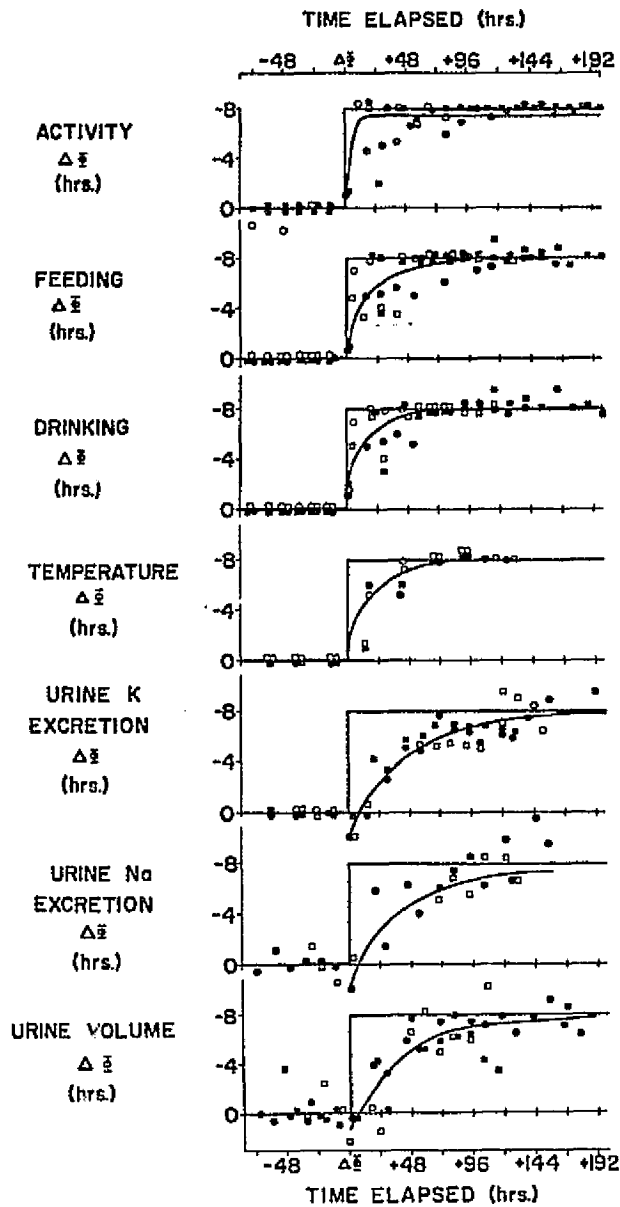

CIRCADIAN VARIATION IN RESPONSE TO POTASSIUM INFUSION IN MAN[†]

Martin C. Moore-Ede

Michael M. Meguid

Garry F. Fitzpatrick

Caryl M. Boyden

Margaret R. Ball

Department of Surgery, Harvard Medical School at the Peter Bent
Brigham Hospital and Department of Physiology, Harvard Medical
School, Boston, Massachusetts 02115.

Running Title: CIRCADIAN VARIATION IN POTASSIUM TOLERANCE

Correspondence To: Dr. M.C. Moore-Ede, Department of Physiology,
Harvard Medical School, 25 Shattuck Street, Boston, Massachusetts
02115.

[†] Abstract Submitted to Clinical Research, 1976.

ABSTRACT The response of five normal men to an intravenous infusion of potassium chloride was compared at midday and midnight. Each subject was maintained on strict supine bedrest with oral intake limited to 100 ml distilled water/hour for the nine hours prior and nine hours post each infusion. 37 meq potassium chloride (with an added label of 200 μ Ci 42 KCl) in iso-osmolar solution was administered via a central venous catheter over one hour starting either at midday or midnight. Plasma potassium concentration was elevated by 40% more at midnight than at midday, and plasma 42 K activity also rose to a higher level at midnight. These differences were reflected by greater T-wave elevations of the EKG at midnight than at midday. However, urinary potassium excretion (total and 42 K labelled) was higher at midday than at midnight indicating that there was a reduced renal excretory responsiveness to elevations in plasma potassium concentration at midnight as compared to midday. Plasma aldosterone concentration rose during the potassium infusions at both midday and midnight by a similar amount suggesting that adrenal secretory responsiveness to plasma potassium elevations was not a major determinant of the differing renal response. These findings confirm predictions of circadian variations in potassium handling made from our previous studies of endogenous circadian fluxes of potassium between body compartments, and indicate that special caution must be taken in administering potassium infusions at night.

INTRODUCTION

Many biochemical, physiological and behavioral processes demonstrate endogenous circadian rhythms which will persist in the absence of environmental variation (1,2). These circadian variations appear to represent internally timed adaptations to environmental changes which are predictably correlated with the earth's 24 hour day-night cycle. Increasingly, the clinical significance of these internally preprogrammed circadian variations is being realized. The effectiveness and toxicity of drugs (3,4), and the response to trauma (5) and to toxins (6) have been shown to vary predictably with the time of day.

That man has prominent circadian rhythms in urinary water and electrolyte excretion has been known for over one hundred years (7,8). The independence of these circadian rhythms from day-night patterns of dietary intake, activity and posture has also long been recognized (9,10,11). Recently, we have demonstrated that the urinary potassium rhythm represents one component of a circadian variation in potassium distribution between body compartments (12). We found a net influx of potassium out of the intracellular compartment (e.g., muscle and erythrocytes) into the extracellular fluid during the daytime hours and a net influx of potassium in the reverse direction at night. These fluxes were counterbalanced by the circadian variation in urinary potassium excretion so that fluctuations in extracellular potassium content were minimized. Furthermore, these fluxes persisted despite the subjects being maintained on constant supine bedrest with identical small meals at three-hourly intervals throughout day and night.

Frequently, rapid intravenous infusions of 40 meq potassium or more may be given to patients with clinically significant hypokalemias. Caution must always be exercised, however, because of the potent cardiotoxicity of potassium. Because of the persistence and the stability of the circadian intercompartmental fluxes of potassium, we undertook to examine whether these circadian variations influence the way in which the body responds to an exogenously administered potassium load at different times of day. We have compared the effects of administering identical potassium infusions to normal volunteers at two different phases of the circadian cycle. The times of potassium administration chosen (midday and midnight) were those which demonstrated the maximum contrast in rate and direction of intercompartmental potassium fluxes in our previous study.

METHODS

Five healthy male volunteers, aged 21-26, were studied in the Bartlett Intensive Care Unit of the Peter Bent Brigham Hospital. Normality was established by clinical history, physical examination, and biochemical screening. All subjects were non-smokers, had normal three-hour oral glucose tolerance tests and had signed an informed consent.

Throughout the week prior to the study, the volunteers were maintained on a strict diet which provided 100 meq of potassium, 150 meq of sodium, and 2400 calories per 24 hours. The food was prepared in the dietary kitchens and served as three meals per day. The subjects were maintained on a 24-hour sleep-wake cycle with lights on at 7 am and off at 11 pm daily.

Twenty-four hours prior to the study, the volunteers were admitted to the Intensive Care Unit. Under local anesthesia, a central venous catheter was inserted through an antecubital vein. The position of the tip was situated in the superior vena cava approximately 3 cm above the right atrium, and this location was confirmed by chest X-ray. The catheter was maintained patent by a slow infusion of 0.45% saline at 30 ml/hr. In the opposite arm a heparin lock was inserted into a peripheral vein to facilitate blood sampling.

Each subject was administered two identical infusions of isosmolar (296 mOsm/L) potassium chloride solution containing 37 meq potassium in 250 ml distilled water, to which was added 200 μ Ci of ^{42}KCl . One solution was infused at midnight and the other at midday, 36 hours later. The order of administration of these potassium infusions was alternated between each successive subject.

Identical conditions for the midnight and midday infusions were maintained. For the nine hours prior to and following each infusion, the subjects were required to maintain supine bedrest with no dietary intake, except for the hourly ingestion of 100 ml distilled water. Beginning at midnight (or midday), the subjects were administered the potassium infusion via their central venous catheter at a constant rate over one hour. The slow saline infusion was interrupted for the length of the potassium chloride infusion. The subjects reported no discomfort during the course of the experiment.

At 0, 30, 50, and 70 minutes after the start of the potassium infusion, 12-lead EKG tracings were obtained from each subject. Venous

blood samples were drawn via the heparin lock immediately preceding the potassium infusion and at 20, 40, 60, 90, 120, and 180 minutes following the start of the infusion. The blood was drawn slowly without the use of a tourniquet or fist pumping and mixed with lithium heparin (100 U/100 ml) in potassium free glassware. Plasma was then obtained by spinning the sample for 20 minutes at 2,700 rpm at 15 cm radius and respinning the supernatant plasma for 10 minutes.

A 1 ml aliquot of plasma was frozen at -20°C for subsequent radioimmunoassay for cortisol and aldosterone in the laboratory of Dr. Gordon M. Williams (13). A second aliquot was diluted to 10 ml with distilled water and counted for ^{42}K activity to a statistical accuracy of at least 1% in a Nuclear-Chicago Mark 1 Liquid Scintillation Spectrometer using the principle of Cerenkov radiation (14). Counts per minutes were corrected for quenching using a predetermined channel-ratio quench curve and then were corrected for radioactive decay. The results from the second of the two infusions were corrected for the residual counts remaining after the first infusion. The remaining plasma was analyzed for potassium and sodium concentration by flame photometry (Instrumentation Laboratory Model 343L, Lexington, Massachusetts) using an internal lithium standard; for plasma glucose concentration by the Hoffman method (15) using Technicon Autoanalyzer (Technicon Instrument Corporation, Tarrytown, New York); and for plasma osmolality by freezing point depression using an Advanced Instruments Model 31 Osmometer (Newton Highlands, Massachusetts).

Urine was collected in three hourly aliquots from nine hours before the potassium infusion until nine hours after the start of the potassium

infusion. Each collection contained all urine voided during the 3-hour period, including a voluntary bladder emptying at the end of the period. Within a few minutes of collection, the volume of each 3-hour urine collection was measured. A 5 ml aliquot was removed and diluted to 10 ml with distilled water for liquid scintillation counting of ^{42}K counts as described above. A further 20 ml urine aliquot was acidified with two drops of 25% sulfuric acid and refrigerated at 4°C. Urinary potassium concentration was estimated on the 1L flame photometer. The rate of urinary potassium excretion (meg/hr) was calculated from the 3-hour urine volume, the urinary potassium concentration and the time interval (3 hours) over which the sample was collected.

Data Analysis. An analysis of variance (ANOVA) was performed for each plasma variable to partition the variance between "time of infusion" effect (i.e., midnight vs. midday), between subjects effects ("subjects"), and between the successive samples after each infusion ("samples"). Since there was no replication of each data point the interaction term "time of infusion x subjects x samples" was used as the denominator in the F test. Plasma potassium, sodium, glucose, and osmolality samples were obtained from all five subjects. Plasma ^{42}K activity and aldosterone were estimated in four subjects and plasma cortisol in three. These latter variables were added to the protocol after it became clear they would be valuable in the interpretation of the experimental findings.

RESULTS

Figure 1 compares the changes in plasma potassium concentration after the potassium chloride infusions starting at midday and midnight. After the midnight infusion plasma potassium concentration rose to a significantly higher ($p < 0.02$) maximum level than at noon and then returned more slowly towards the baseline. Table 1A gives the results of the ANOVA demonstrating a significant ($p < 0.01$) time of infusion effect on plasma potassium concentration.

Figure 2 shows the changes in plasma sodium, glucose and osmolality after the potassium infusions at midday and midnight. There was a slight fall in plasma sodium and plasma glucose concentrations after each of the potassium infusions, but this was only detected as a significant ($p < 0.05$) sample effect by ANOVA for plasma sodium concentration (Table 1B). There was no difference in the response of plasma sodium, glucose or osmolality between the midday and midnight infusions as shown by statistically insignificant ANOVA time of infusion effects (Tables 1B, 1C, and 1D).

The patterns of urinary potassium excretion during the nine hours prior to and following the start of the potassium infusions are shown in Figure 3. During the nine hours immediately prior to the infusion, with subjects maintained on constant bedrest without food intake, urinary potassium excretion fell progressively in the pre-midnight urine samples but rose progressively during the pre-midday urine samples, thus reflecting the normal circadian rhythmicity in urinary potassium excretion under externally constant conditions (12). During the three hour urine collection immediately following the potassium infusion, urinary potassium

excretion at midday rose to almost twice the level seen during the equivalent period at midnight ($p < 0.01$). This occurred despite the elevation in plasma concentration being less at midday than at midnight (See Figure 1).

Because of the difficulty in distinguishing between the normal circadian baseline changes in potassium distribution, and the responses to the exogenous potassium infusion, radioactively labelled ^{42}KCl was added to each infusion. Figure 4 shows that the differences in handling of exogenously administered ^{42}K between midday and midnight are in agreement with the conclusions reached from the study of total potassium concentration. The plasma ^{42}K activity rose to a higher level at midnight than midday and fell more slowly after the midnight infusion. The ANOVA (Table 1E) demonstrates that this time of infusion effect was statistically significant ($p < 0.01$). The percent of the exogenously administered ^{42}K which was excreted in the urine in the first three hours after the start of the infusion was significantly greater at midday than at midnight ($p < 0.05$), also supporting the conclusion reached from the total potassium studies.

The differences in plasma potassium concentration following the intravenous potassium infusions at midnight and midday were reflected by the changes in the EKG patterns. Although no dangerous signs of hyperkalemia were seen, T wave elevations were observed in each subject. These elevations were most prominent in the chest leads V_4 , V_5 , and V_6 . In V_4 at midday, there was a $48 \pm 13\%$ T wave elevation, but at midnight, this was $84 \pm 22\%$. In V_5 there was a $18 \pm 3\%$ elevation at midday and a $52 \pm 10\%$ elevation at midnight ($p < 0.01$) and in V_6 the midday elevation was $21 \pm 6\%$,

while the midnight change was $45 \pm 14\%$.

A major component of the midday-midnight difference in response to the potassium load was the differing renal excretory response to elevations in plasma potassium concentration. This is illustrated in Figure 5 where urinary potassium excretion rate is plotted against the mean plasma potassium concentration during the time interval over which the urine was formed. The urine collections intervals used for each subject were the three-hour urine samples immediately before and immediately after the start of the potassium infusions at midday and midnight. The points on the graph therefore represent data collected both before and during the elevation in plasma potassium concentration induced by intravenous potassium infusion. The slope of the relationship between the plasma potassium concentration and urinary potassium excretion was significantly greater ($p < 0.01$) at midday than at midnight by covariance analysis. Thus, the kidneys appeared to be much more responsive to elevations in plasma potassium concentration at midday than at midnight.

To determine whether the differences in response to the potassium infusions at midday and midnight were secondary to changes in the responsiveness of the adrenal cortex, plasma cortisol and aldosterone concentrations were simultaneously determined in these experiments. Figure 6 shows that plasma cortisol concentration showed a progressive fall in concentration throughout the midday study, but remained at low levels at midnight. This was detected as a significant ($p < 0.01$) time of infusion effect by ANOVA (Table F). However, these changes were consistent with the normal circadian pattern of plasma cortisol concentration (16,17), and probably did

not represent a response to the potassium infusion.

Plasma aldosterone concentration (Figure 6) rose in response to the potassium infusion at both midday and midnight, with both the baseline and peak levels being higher at midday than midnight. The ANOVA demonstrated a significant ($p < 0.01$) time of infusion effect (Table IC). However, there was no midday-midnight difference in the incremental response of plasma aldosterone over pre-infusion baseline levels. When the relationship between plasma potassium concentration and plasma aldosterone was plotted by the method of Dluhy, et. al. (18) (Figure 7), covariance analysis indicated a significantly different ($p < 0.05$) mean level, but no significant difference in slope. Thus, there appeared to be no difference between midnight and midday in the responsiveness of aldosterone secretion to a given elevation of plasma potassium concentration.

DISCUSSION

In his original formulation of the concept of homeostasis, Cannon recognized that physiological systems could oscillate and that there was often no single steady-state point to which they return after an environmentally induced perturbation (19). Since that time, however, there has been a tendency to over-simplify the concept of homeostasis and assume that identical levels of physiological function pertain at all points in the twenty-four hour day, provided behavioral and environmental conditions are similar. That this assumption is manifestly untrue has been documented in many hundreds of studies of endogenous circadian rhythmicity in man (2) and other organisms (1).

When identical isosmotic one-hour infusions of 37 meq potassium chloride were given to normal volunteers at midnight and midday there were substantial differences in the physiological response. Plasma potassium concentration rose by 40% more at midnight than at midday despite the subjects at both times being maintained for nine hours previously on strict supine bedrest with no oral intake except for distilled water. A major contributor to the differing elevations in plasma concentration was the renal excretory response. The rate of urinary potassium excretion after the midday potassium infusion was greater, even though the plasma potassium concentration did not rise as high as at midnight. Studies with ^{42}K confirmed that the plasma concentration of administered potassium was higher at midnight, while the rate of urinary excretion of the exogenous potassium load was lower at this time.

Dluhy, et. al. (18), have shown that the rate of aldosterone secretion is highly sensitive to the plasma concentration of potassium, and that there is a linear relationship between the increments in plasma potassium and aldosterone concentration after an exogenously administered potassium infusion. We examined the plasma aldosterone response to potassium infusion at midnight and midday to determine whether this might play a role in the differing renal responsiveness. Plasma aldosterone concentration was higher throughout the potassium infusion at midday than at midnight, but it was also higher by a similar amount prior to the start of the infusion, so that the incremental rise of plasma aldosterone concentration was no higher at midday than at midnight. This suggests that while the circadian rhythm in plasma aldosterone concentration

may play a role in the "setting" of the renal responsiveness to changes in plasma potassium concentration, it does not play a major role in the differences in the immediate renal response to the potassium infusion at midnight and midday.

This study was prompted by our previous demonstration of prominent and stable circadian oscillations in potassium flux between body compartments in man (12). The most easily monitored component of these potassium fluxes, the circadian rhythm of renal potassium excretion, has been shown to persist despite experimental manipulations of dietary intake (9-11,20), posture and locomotor activity (12,21), and the isolation of subjects from all external time cues (22). Further evidence for the stability of these potassium rhythms in clinically-applicable situations has been provided by Reinberg, et. al. (23) who demonstrated the continuance of a statistically significant urinary potassium rhythm in patients with drug overdose-induced coma.

The stability and persistence of these rhythms of potassium flux suggested that they might be an important consideration in the dosage and timing of therapies which influence body potassium distribution. The potentially-serious cardiac effects of hypo- and hyperkalemia are well known (24), and are an important concern during the administration of intravenous potassium infusion. For obvious ethical reasons the potassium infusion used in the present study induced changes in plasma potassium concentration which were well below those causing dangerous cardiac effects. Yet the 40% higher elevation in plasma potassium concentration seen at midnight versus midday must be of concern for this

could clearly tip the balance between toxicity and a non-serious effect. Greater T wave changes in the EKG were seen at midnight than at midday supporting this conclusion. We would therefore recommend that extra caution be taken with the administration of potassium during the night.

Recent evidence from our group (25), indicates that the circadian rhythms which are observed in many physiological variables are the outputs of a multioscillator system. The component oscillators are situated in various body tissues and appear to be internally coupled with one another via circadian rhythms in hormonal and nervous mediators. The mechanism of these circadian oscillators are as yet poorly understood. Recently, however, there has been increasing evidence to support the concept formulated by Njus, Sulzman, and Hastings (26) that the fundamental circadian oscillator mechanism is a feedback interaction between transmembrane potassium gradients and the activity of membrane-located ion transport proteins. If this hypothetical scheme proves correct then the circadian fluxes of potassium between body cells and the extracellular fluid may be of more than clinical significance.

ACKNOWLEDGEMENTS

The authors are grateful for the support and encouragement of Dr. Francis D. Moore. They also wish to thank Ms. Lourdes Holejko and Ms. Anna Kaczowka for their assistance in the laboratory, and Ms. Wendy Schmelzer, Ms. Kathy Cohen and Ms. Margaret Harrigan for their help in the preparation of the manuscript. The work was supported by NIH grant HL-13872 and NASA contract NAS9-14249.

REFERENCES

1. Bunning, E. 1973. The Physiological Clock. Springer-Verlag, New York 3rd Edition.
2. Conroy, R.T.W.L. and J.N. Mills. 1970. Human Circadian Rhythms. J. & A. Churchill, London.
3. Moore-Ede, M.C. 1973. Circadian Rhythms of Drug Effectiveness and Toxicity. Clin. Pharm. Ther. 14: 925-935.
4. Reinberg, A. and F. Halberg. 1971. Circadian Chronopharmacology Ann. Rev. Pharmacol. 11: 455-492.
5. Halberg, F., J.J. Bittner, R.J. Gully, P.J. Albrecht, and E.L. Brackney. 1955. 24-hour Periodicity and Audiogenic Convulsions in I Mice of Various Ages. Proc. Soc. Expt. Biol. Med. 88: 169-173.
6. Halberg, F. E. Johnson, W. Brown, and J.J. Bittner. 1960. Susceptibility Rhythm to E. coli Endotoxin and Bioassay. Proc. Soc. Expt. Biol. Med. 103: 142-144.
7. Roberts, W. 1860. Observations on Some of the Daily Changes in the Urine. Edin. Med. J. 5: 817-825 and 906-923.
8. Weigelin, J. 1868. Versuche uber die Harnstoffausscheidung Wahrend und nach der Muskel Thetigkeit. Arch. Anat. Physiol. Wissensch. Med. 207-223.
9. Simpson, G.E. 1924. Diurnal Variations in the Rate of Urine Excretion for Two-Hour Intervals: Some Associated Factors. J. Biol. Chem. 59: 107-122.
10. Simpson, G.E. 1926. The Effect of Sleep on Urinary Chloride and pH. J. Biol. Chem. 67: 505-516.

11. Norn, M. 1929. Untersuchungen über das Verhalten des Kalium im Organismus. II. Über Schwankungen der Kalium, Natrium, und Chlondausscheidung durch die Niere im Laufe des Tages. Skand. Arch. Physiol. 55: 184-210.
12. Moore-Ede, M.C., M.F. Brennan and M.R. Ball. 1975. Circadian Variation of Intercompartmental Potassium Fluxes in Man. J. Appl. Physiol. 38: 163-170.
13. Underwood, R.H. and G.H. Williams. 1972. The Simultaneous Measurement of Aldosterone, Cortisol and Corticosterone in Human Peripheral Plasma by Displacement Analysis. J. Lab. Clin. Med. 79: 848-862.
14. Johnson, J.E. and J.M. Hartsuck. 1969. Counting of ^{42}K by Cerenkov Radiation. Health Physics 16: 755-756.
15. Hoffman, W.S. 1937. A Rapid Photoelectric Method for the Determination of Glucose in Blood & Urine. J. Biol. Chem. 120: 51-55.
16. Perkoff, G.T., K. Eik-Ness, C.A. Nugent, H.L. Fred, R.A. Nimer, L. Rush, L.T. Samuels and F.M. Tyler. 1959. Studies of the Diurnal Variation of Plasma 17-hydroxycorticosteroids in Man. J. Clin. Endocr. 19: 432-443.
17. Czeisler, C.A., M.C. Moore-Ede, Q.R. Regestein, E.S. Kisch, V.S. Fang, and E.N. Ehrlich. 1976. Episodic 24-hour Cortisol Secretory Patterns in Patients Awaiting Elective Cardiac Surgery. J. Clin. Endocr. Metab. 42: 273-283.

18. Dluhy, R.G., L. Axelrod, R.H. Underwood and G.F. Williams. 1972. Studies of the Control of Plasma Aldosterone Concentration in Normal Men. II. Effect of Dietary Potassium and Acute Potassium Infusion. *J. Clin. Invest.* 51: 1950-1957.
19. Cannon, W.B. 1929. Organization for Physiological Homeostasis. *Physiol. Rev.* 9: 399-431.
20. Borst, J.G.G. and L.A. DeVries. 1950. The Three Types of "Natural" Diuresis. *Lancet* 2: 1-6.
21. Mills, J.N. and S.W. Stanbury. 1952. Persistent 24-hour Renal Excretory Rhythm on a 12 hour Cycle of Activity. *J. Physiol. (Lond.)*. 117: 22-37.
22. Aschoff, J. 1965. Circadian Rhythms in Man. *Science* 148: 1427-1432.
23. Reinberg, A., P. Gervais, E. Pollak, C. Abulker and J. Dupont. 1973. Circadian Rhythms During Drug-Induced Coma. *Int. J. Chronobiol.* 1: 157-162.
24. Wintrobe, M.M., Editor. 1974. *Harrison's Principles of Internal Medicine*. McGraw-Hill, New York, 7th Edition. 441-442.
25. Moore-Ede, M.C., W.S. Schmelzer, D.A. Kass and J.A. Herd. 1976. Internal Organization of the Circadian Timing System in Multi-cellular Animals. *Fed. Proc.* In Press.
26. Njus, D., F.M. Sulzman, and J.W. Hastings. 1974. Membrane Model for the Circadian Clock. *Nature* 248: 116-119.

FIGURE LEGENDS

- FIGURE 1 Comparison of the mean \pm SEM changes in plasma potassium concentration in response to one-hour potassium chloride infusions starting at midday (○) and midnight (⊙).
- FIGURE 2 Comparison of the changes in plasma sodium, glucose and osmolality in response to midday and midnight potassium chloride infusions.
- FIGURE 3 Urinary potassium excretion rates for the nine hours prior to and the nine hours following the start of the midday and midnight potassium infusions.
- FIGURE 4 Plasma ^{42}K activity (left side) and percent of infused ^{42}K dose excreted in each urine sample (right side) after midday and midnight potassium infusions. 200 μCi of ^{42}KCl was added to each 37 meq potassium infusion.
- FIGURE 5 Relationship between urinary potassium excretion and the mean plasma potassium concentration during the same time period. Least-squares regression lines were fitted separately to the data obtained at midnight and at midday.
- FIGURE 6 Plasma concentrations of aldosterone (upper section) and cortisol (lower section) during the three hours after the start of the potassium chloride infusions at midday and midnight.
- FIGURE 7 Relationship between plasma potassium and aldosterone concentrations in simultaneously collected samples during the three hours after the start of the potassium chloride infusions at midday and midnight.

TABLE I

Analyses of Variance (ANOVA) for Responses of Plasma
Variables to Potassium Chloride Infusion

A. Plasma Potassium Concentration

	DF	SS	MS	F
Time of Infusion	1	0.7459	0.7459	78.44**
Subjects	4	0.8415	0.2104	22.12**
Samples	5	5.8609	1.1722	123.26**
Time of Infusion x Subjects	4	0.3312	0.0823	8.71**
Time of Infusion x Samples	5	0.0557	0.0111	1.17*
Subjects x Samples	20	0.2937	0.0147	1.54*
Time of Infusion x Subjects x Samples	20	0.1902	0.0095	
Total	59	8.3191	0.1410	

B. Plasma Sodium Concentration

Time of Infusion	1	0.0135	0.0135	0.0211
Subjects	4	12.1327	3.0332	5.26**
Samples	5	8.5008	1.7002	2.95*
Time of Infusion x Subjects	4	6.3240	1.5810	2.74
Time of Infusion x Samples	5	2.6635	0.5327	0.92
Subjects x Samples	20	14.7233	0.7362	1.28
Time of Infusion x Subjects x Samples	20	11.5240	0.5762	
Total	59	55.8818	0.9471	

TABLE I (cont.)

C. Plasma Glucose Concentration

Time of Infusion	1	64.0667	64.0667	3.34
Subjects	4	227.2333	56.8083	2.96*
Samples	5	83.2000	16.6400	0.87
Time of Infusion x Subjects	4	282.1000	70.5250	3.68*
Time of Infusion x Samples	5	153.5333	30.7067	1.60
Subjects x Samples	20	214.9667	10.7483	0.56
Time of Infusion x Subjects x Samples	<u>20</u>	<u>383.3000</u>	<u>19.1650</u>	
Total	59	1408.4000	23.8712	

D. Plasma Osmolality

Time of Infusion	1	5.4000	5.4000	3.29
Subjects	4	149.7333	37.4333	22.83**
Samples	5	1.7333	0.3467	0.21
Time of Infusion x Subjects	4	36.6000	9.1500	5.58**
Time of Infusion x Samples	5	5.2000	1.0400	0.63
Subjects x Samples	20	47.2667	2.3633	1.44
Time of Infusion x Subjects x Samples	<u>20</u>	<u>32.8000</u>	<u>1.6400</u>	
Total	59	278.7333	4.7243	

TABLE I (cont.)

E. Plasma ^{42}K Activity

	DF	SS ($\times 10^{-5}$)	MS ($\times 10^{-5}$)	F
Time of Infusion	1	2.5085	2.5085	13.28**
Subjects	3	14.5146	4.8382	25.62**
Samples	5	97.7979	19.5596	103.56**
Time of Infusion x Subjects	3	1.5287	0.5096	2.70
Time of Infusion x Samples	5	0.4171	0.0834	0.44
Subjects x Samples	15	6.6873	0.4458	2.36
Time of Infusion x Subjects x Samples	<u>15</u>	<u>2.8331</u>	<u>0.1889</u>	
Total	47	126.2872	2.6870	

F. Plasma Cortisol Concentration

	DF	SS	MS	F
Time of Infusion	1	83.4438	83.4438	27.23**
Subjects	2	52.7957	26.3979	8.61**
Samples	6	114.5629	19.0938	6.23**
Time of Infusion x Subjects	2	103.7462	51.8731	16.93**
Time of Infusions x Samples	6	49.8295	8.3049	2.71
Subjects x Samples	12	57.3743	4.7812	1.56
Time of Infusion x Subjects x Samples	<u>12</u>	<u>36.7705</u>	<u>3.0642</u>	
Total	41	498.5229	12.1591	

TABLE I (cont.)

G. Plasma Aldosterone Concentration

Time of Infusion	1	84.2802	84.2802	10.34**
Subjects	3	271.9520	90.6507	11.13**
Samples	6	644.2975	107.3829	13.18**
Time of Infusion x Subjects	3	9.0020	3.0007	0.37
Time of Infusion x Samples	6	47.1011	7.8502	0.96
Subjects x Samples	18	160.5468	8.9193	1.09
Time of Infusion x Subjects x Samples	<u>18</u>	<u>146.6518</u>	<u>8.1473</u>	
Total	55	1363.8314	24.7969	

* = $p < 0.05$ ** = $p < 0.01$

Fig 1

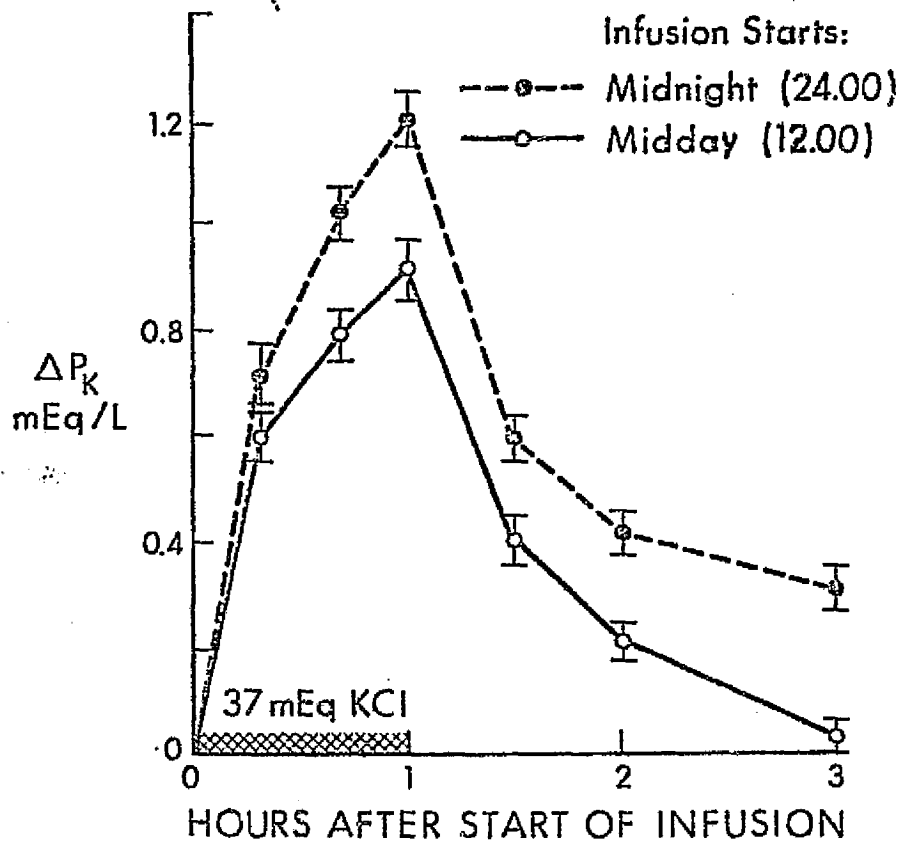

PRECEDING PAGE BLANK NOT FILMED

Fig. 2.

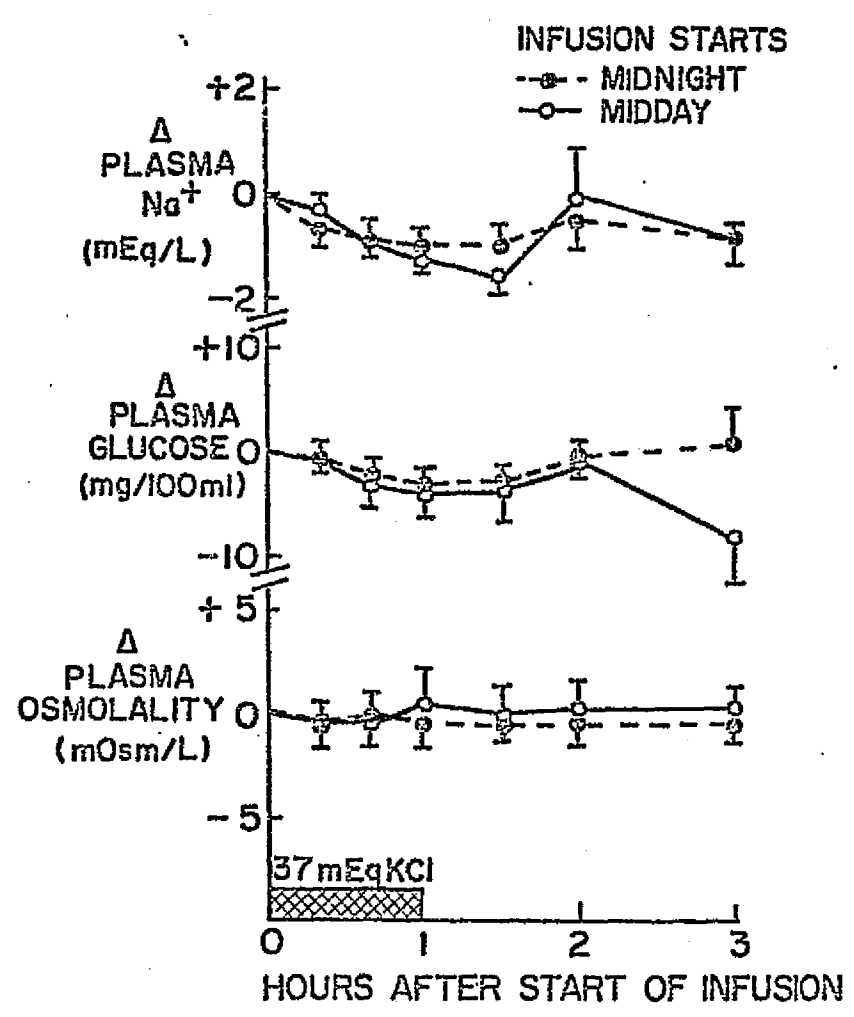

Fig 3

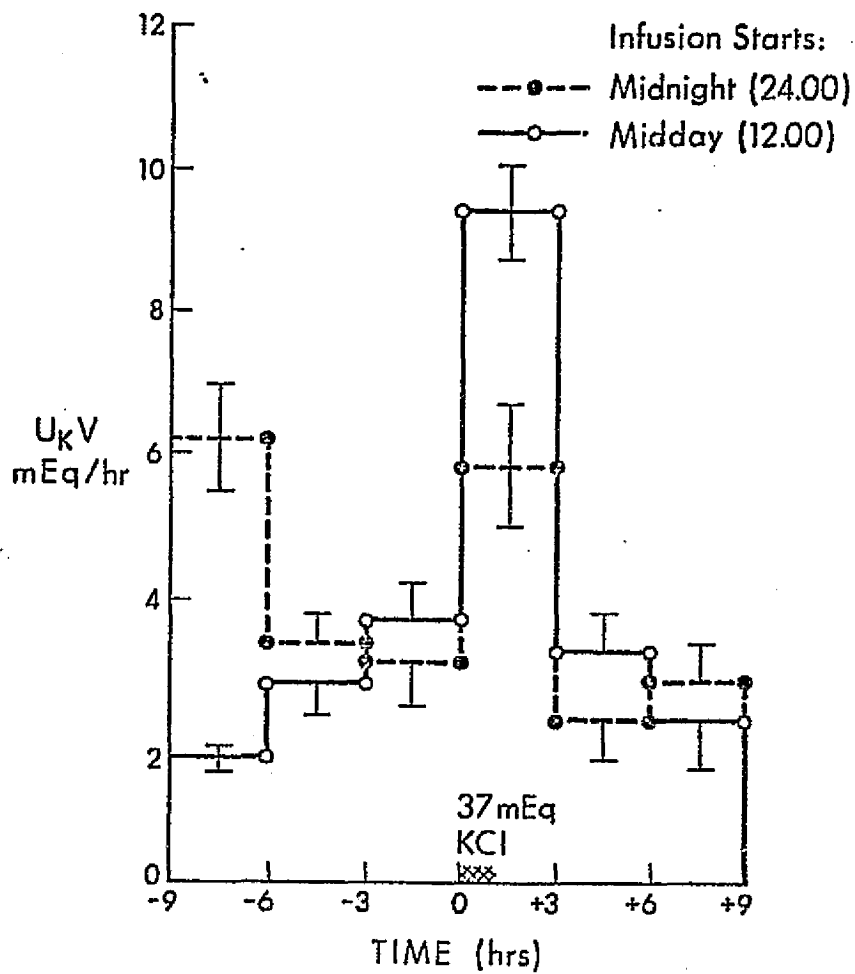

Fig 4

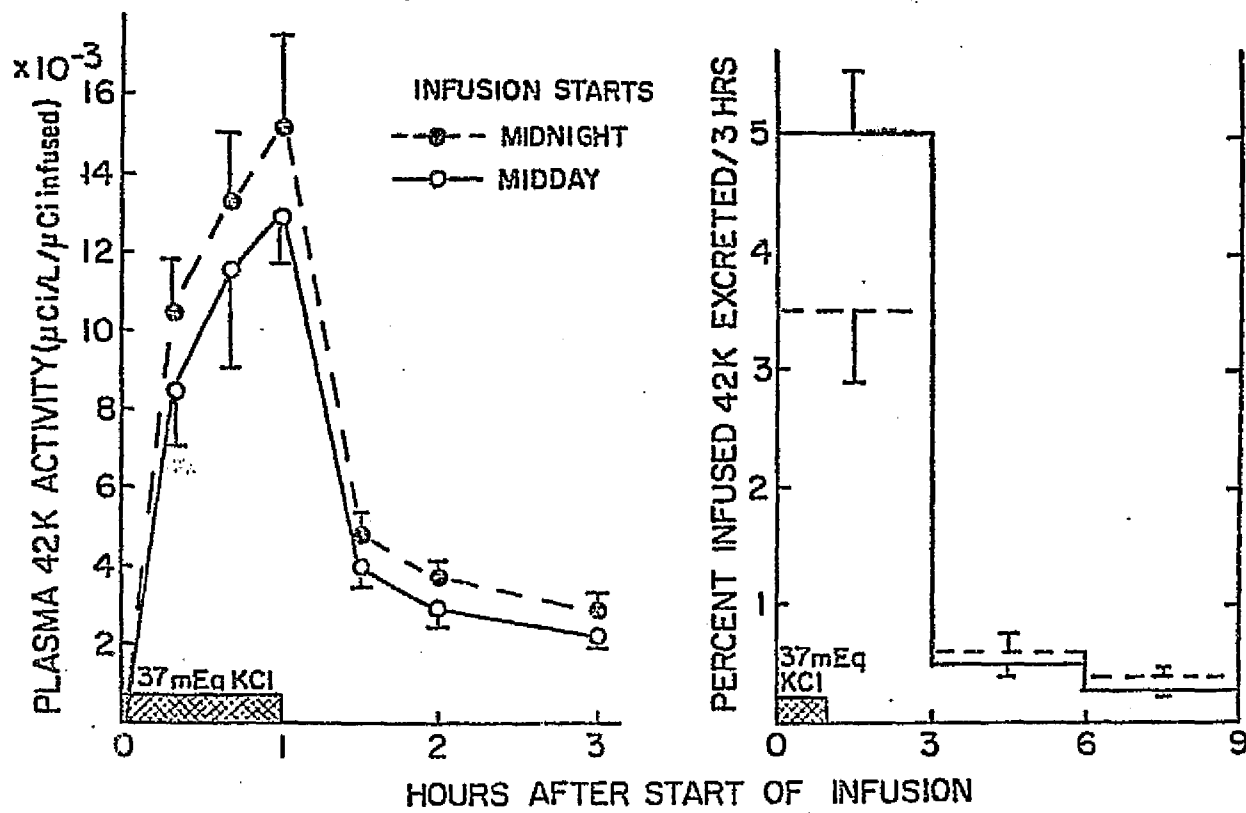
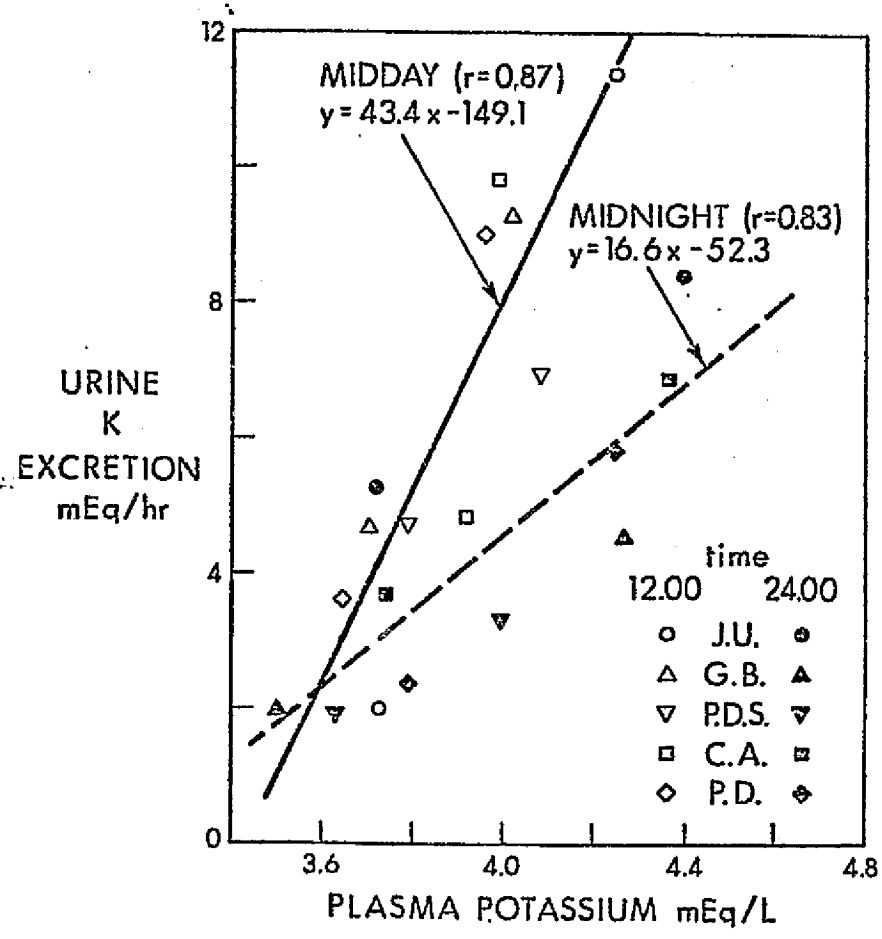

Fig 5



7/2/6

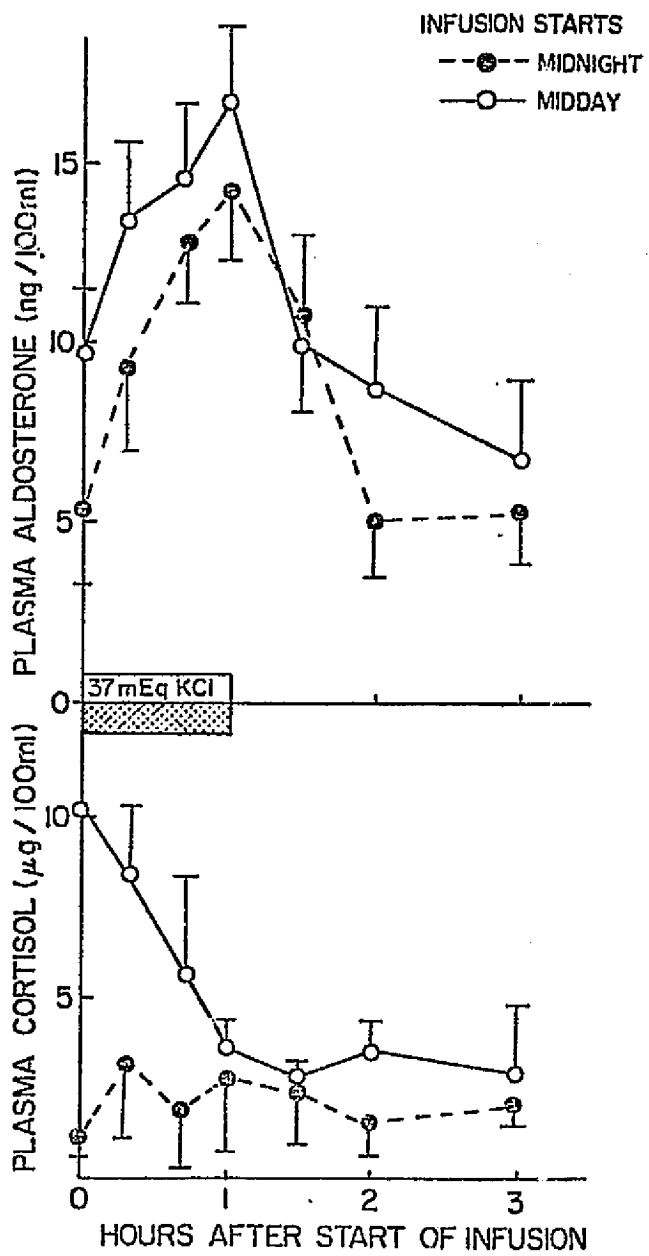
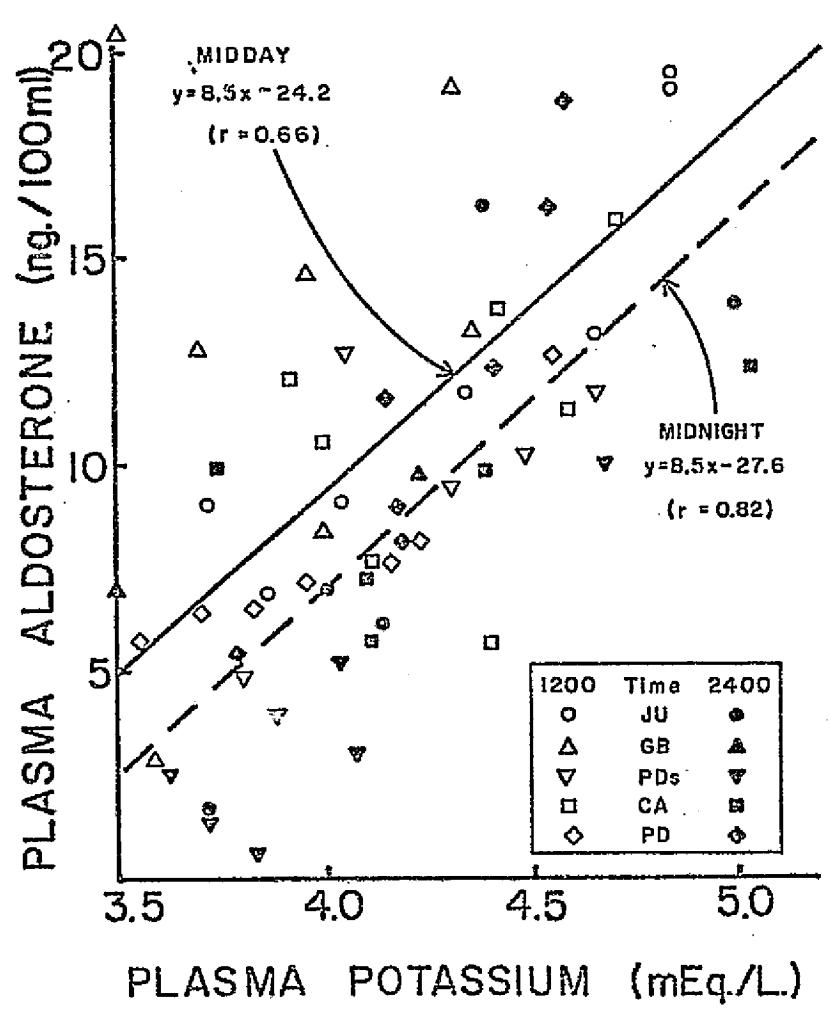

Fig 7



SPECIFICITY OF CORTISOL AS A MEDIATOR
OF CIRCADIAN RHYTHMS IN THE SQUIRREL MONKEY

Frank M. Sulzman

Charles A. Fuller

Martin C. Moore-Ede

Department of Physiology
Harvard Medical School
Boston, Massachusetts 02115

Running Title: CIRCADIAN SYNCHRONIZATION BY CORTISOL

Correspondence To: Dr. M.C. Moore-Ede
Department of Physiology
Harvard Medical School
25 Shattuck Street
Boston, MA 02115

SUMMARY

The circadian timing system in primates consists of an organization of multiple oscillators in various tissues internally synchronized through hormonal and neural coupling. To test the specificity of the circadian rhythm of plasma cortisol concentration as a synchronizing mediator, adrenalectomized, chair-acclimatized squirrel monkeys (Saimiri sciureus) were studied. With each monkey isolated in constant light (600 lux), a pulse of 10 mg cortisol was administered via a chronically implanted venous catheter at 08:00 hr daily. The circadian rhythm of renal potassium excretion was entrained to a 24 hr period by the cortisol rhythm, but the circadian rhythms in feeding and body temperature were not synchronized by cortisol. These findings demonstrated that the plasma cortisol rhythm acts as an internal synchronizer of renal potassium excretion, but plays no role as a general hormonal coupler of circadian oscillators. Furthermore, the oscillators which comprise the circadian timing system would appear to be arranged in a hierarchical organization so that the feedback action of cortisol on the pituitary-adrenal axis does not synchronize the entire circadian system.

INTRODUCTION

Many biological processes are not constant during the 24 hour day, but instead exhibit regular diurnal variations. When temporal cues from the environment are removed, these diurnal variations may persist with a period of about 24 hours, and hence have been termed circadian rhythms. Their persistence in the absence of temporal information from the environment implies that there is an endogenous system within the organism that is responsible for timing these events. Although diverse biochemical, physiological and behavioral processes within an animal have been shown to simultaneously exhibit circadian rhythmicity, little is known about the nature of organization of circadian timing systems, especially in complex higher organisms such as primates.

Several different lines of experimental evidence suggest that the circadian timing system is composed of a group of oscillators which are normally coupled with one another. There are many reports that isolated tissues maintained in vitro can demonstrate circadian rhythmicity. These include hamster adrenal glands (Andrews and Folk, 1964); rat liver cells (Hardeland, 1973); human red blood cells (Ashkenazi, et al., 1975); Aplysia neural tissue (Strumwasser, 1971; Jacklet and Geronimo, 1971); Drosophila salivary glands (Rensing, 1969); and spider neurosecretory cells (Fowler and Goodnight, 1966). There is also evidence that these tissue oscillators can become uncoupled and free run with different periods within the organism. Such spontaneous internal desynchronization has been observed in human (Aschoff, 1965) and non-human primates (Sulzman, et al., in preparation).

These data indicate that the circadian timing system in higher animals consists of several potentially autonomous oscillators which are normally coupled together to provide internal synchronization. The internal synchronization of the oscillators within the organism is presumably accomplished through neural and hormonal pathways, but as yet, few of these pathways have been identified.

Circadian rhythms in plasma cortisol concentration and urinary potassium excretion are normally synchronized with the light-dark cycle and with other diurnal rhythms in mammals. Recently, Moore-Ede (1974) has shown that plasma cortisol is a mediator involved in synchronizing the circadian rhythm of urinary potassium excretion in the squirrel monkey. If the phase of the plasma cortisol rhythm is artificially changed by administering cortisol to adrenalectomized monkeys so that the peak in plasma cortisol concentration is later than it is in the intact animal, then the timing of the maximum rate of potassium excretion is also phase delayed by a similar amount.

Since cortisol has widespread effects on many body tissues (Thompson and Lippman, 1974), it is possible that cortisol plays a general role as a synchronizer in the circadian timing system. The specificity of cortisol as a mediator in the squirrel monkey was studied by examining whether the circadian rhythm of plasma cortisol concentration is also capable of synchronizing the rhythms of body temperature and feeding behavior in the absence of environmental time cues.

METHODS

Animal Preparation

Adult squirrel monkeys (Saimiri sciureus) were used in these experiments. These small (500-800 g) daytime active South American primates were trained to accept restraint in a metabolism chair within a temperature-controlled isolation chamber for up to three weeks. The metabolism chair, which has been previously described by Moore-Ede and Herd (1976) permits the simultaneous measurement of many physiological and behavioral variables.

Bilateral adrenalectomy was performed on the monkeys. They were fasted overnight, peroperatively prepared with 0.2 cc of 4% Atrophine Sulfate solution intramuscularly and then anesthetized with Halothane in oxygen (Moore-Ede, 1974). The monkeys were allowed at least two weeks to recover from the operation before being studied in any experiment. Once adrenalectomized, the animals were routinely maintained with 20 mg cortisol (cortisone acetate, Merck, Sharp and Dohme) intramuscularly at 08:00 hr daily.

Venous catheters were chronically implanted in each monkey. The catheters were inserted in the internal iliac vein using a sterile operative procedure under Halothane anesthesia. The distal end of the catheter was led out under the skin to the monkey's back, and the external end of the catheter was closed using an obturator. The catheters were protected by placing a light nylon mesh jacket on the monkey. Otherwise, the animal was allowed freedom of movement. The catheters could be maintained for six months or more by flushing them with 0.9% saline solution

daily. During the experiments the catheters were linked to extension tubing which passed outside the isolation chamber. Each day, 10 cc of 0.45% saline solution was continuously infused by an infusion pump (Harvard Apparatus, Model 1991). Hormones, such as cortisol, could be administered intravenously through the catheter without disturbing the animal.

Experimental Protocol

During experiments the animals were placed in the metabolism chair in the isolation chamber where the environmental temperature was maintained at $28 \pm 1^\circ\text{C}$. For at least 3 control days lighting was provided on a light-dark cycle with 600 lux from 08:00 to 20:00 hr EST, and <1 lux from 20:00 to 08:00 hr EST (LD 12:12). After the control LD days, the animal was placed in constant light (LL) of 600 lux for the remainder of the experiment. From 08:00 to 09:00 hr EST each day of the experiment (LD and LL), 10 mg of cortisol (hydrocortisone sodium succinate, Upjohn) was infused into the animal via the venous catheter from outside the chamber. Thus, during the LL phase, the only 24 hourly input to the monkey was the cortisol pulse, with all environmental zeitgebers held at constant levels.

Data Collection and Analysis

Urinary potassium excretion and feeding were measured using previously described methods (Moore-Ede, 1974), and colonic temperature was monitored by inserting a rectal thermister (YSI Model 401) in the monkey. The temperature was recorded on a Grass Instruments Polygraph Recorder. The temperature data, collected at hourly intervals, was digitized from the paper record.

Analysis of significant periodicities in the various simultaneously monitored circadian oscillating functions (feeding, body temperature, and urinary potassium), were undertaken using a program developed by Dr. J.A. Rummel of the Johnson Spaceflight Center, Houston, Texas in collaboration with Dr. Franz Halberg of the Chronobiology Laboratories of the University of Minnesota. This program (Rummel, et. al., 1974) undertakes a combined linear-nonlinear least squares iterative period analysis by a method based on the Marquardt algorithm. This procedure is particularly useful in detecting multiple frequencies in time series data and distinguishing between them even when the periods are very close. Each period of the spectrum can be satisfactorily evaluated for significance, and long data trains can be very readily analyzed. For our analysis, the spectral window size was 0.5 hr and thus the limit of resolution of these periods was ± 0.25 hours.

RESULTS

Figure 1 shows the results from one adrenalectomized monkey for two days of LD and then eight days of constant light (LL). In LD, virtually all of the feeding was confined to the light period. Body temperature began to rise about 2 hours before the lights came on and reached a relatively constant plateau during the day. During the dark phase, the temperature fell to a level of about 2°C lower than the average temperature during the light phase. The maximum rate of urinary potassium occurred during the day and was about twice the minimum rate of urinary potassium excretion during the night.

When the animal is placed into constant light these three functions continued to oscillate with circadian periods. The periodic components from the LL portion of this experiment were analyzed as described in the Methods section. This enabled the rhythms entrained to 24.0 hr period of cortisol administration to be differentiated from the free-running rhythms with periods not equal to 24.0 hr. The period spectra obtained from this analysis are shown in Figure 2. In the bottom three sections the amplitude of the period components of the spectra are plotted, and in the top section of the figure, the statistical significance (p) is given for each period component. The only significant ($p < 0.01$) period for the feeding rhythm was at 25.0 hr. The body temperature rhythm had two major components at 24.5 hr and 27.0 hr and minor component at 20.0 hr. The urinary potassium rhythm showed a dominant period of 24.0 hr, with two smaller amplitude significant components of 15.0 hr and 21.0 hr.

The results of all the experiments we have run following this protocol are listed in Table I. The 24.0 hr cortisol administration cycle entrained the rhythm of urinary potassium excretion to a predominant 24.0 hr period in each of the four experiments. The rhythms of feeding and colonic temperature were not entrained to the cortisol administration cycle as shown by the non-24.0 hr period in seven of the eight cases. Additionally, there were no minor period components of these spectra at 24.0 hr.

DISCUSSION

The circadian rhythms of feeding, colonic temperature and urinary potassium excretion of adrenalectomized monkeys provided with daily cortisol infusions at 08:00 hr EST in LD were found to be similar to the rhythms in intact monkeys (Moore-Ede, 1974). Furthermore, in the present experiments we have shown that the daily administration of cortisol at 08:00 hr EST is a sufficient zeitgeber to synchronize the circadian rhythm of urinary potassium excretion to a 24 hour period in adrenalectomized squirrel monkeys maintained in constant environmental conditions without other time cues. This strongly supports the earlier report of Moore-Ede, et al. (1976) that cortisol is not only a mediator of that rhythm, but also the dominant synchronizer. However, cortisol is not a sufficiently strong zeitgeber to entrain the rhythms of feeding and colonic temperature.

These data provide some information about the internal circadian organization of the squirrel monkey. As suggested in the Introduction, this circadian organization is most adequately described as a multioscillator system. Two alternative multioscillator models which are compatible with previous experimental evidence have been proposed by Moore-Ede, et al. (1976) and these are diagrammatically represented in Figure 3. In Model A, there is a central circadian pacemaker which can be entrained to environmental time cues. This pacemaker synchronizes the various potentially-independent oscillators throughout the body. The peripheral circadian oscillators are normally synchronized by the central pacemaker via circadian rhythms in neural activity and/or hormonal concentrations. In Model B, there is no single central pacemaker. Instead, internal synchronization within the

organism is maintained by mutual feedback coupling of mediators between the separate oscillating units. Each of these two models can account for the occurrence of internal desynchronization where different rhythmic functions show independent periods within the same organism.

In the hierarchical scheme, Model A, artificial manipulation of a mediator would affect only the rhythms in the pathways under direct control of that mediator. In contrast in the non-hierarchical system (Model B), mediators may influence (through feed back interaction) other rhythms which are not directly controlled by that mediator. The results of this study show that the manipulation of cortisol, a mediator of the circadian rhythm of urinary potassium excretion, results in the synchronization of that rhythm. That cortisol does not entrain the rhythms of feeding and body temperature supports, at least in part, the hierarchical model of internal circadian organization (Model A).

It is interesting to note that within an experiment, the periods of the body temperature and feeding rhythms were not always synchronized with each other. The differences in periods may reflect the occurrence of internal desynchronization as has been observed in intact squirrel monkeys (Sulzman, et. al., in preparation). On the other hand, although we have shown that cortisol does not synchronize these rhythms, it is a very potent agent with widespread effects at many sites throughout the body (Thompson and Lippman, 1974). It is therefore possible that the interaction between the imposed 24 hr period of plasma cortisol concentration and the free running oscillators causes the differences in periods.

In addition to the specific results we have obtained from these experiments, the protocols we have developed should allow us to examine the

role that other hormones play in the internal organization of the circadian system. The administration of agents via chronically implanted catheters which extend outside of the isolation chamber permits rigid control of temporal information. These techniques allow total control over the temporal profiles of different hormonal mediators, and thus various hormones can be screened for their involvement in circadian timing systems.

Periods of Rhythms in LL with Cortisol Daily at 08:00 hrs

Experiment Number	Variable			Days in LL
	Urinary K ⁺	Temperature	Feeding	
1	24.0**	24.5**	25.0**	8
2	24.0**	26.0**	25.0**	5
3	24.0**	25.0**	24.0**	9
4	24.0**	24.5**	24.5*	14

** = $p < 0.01$

* = $p < 0.05$

Figure 1

Persisting circadian variations of one animal in feeding (top), body temperature (middle) and urinary potassium excretion (bottom) for two days in LD 12:12 (lights on 08:00 - 20:00 hr EST) and then eight days in LL. Feeding is plotted as the number of food pellets consumed per two hourly interval; body temperature is in °C; and urinary potassium excretion is expressed as micro equivalents of potassium excreted per hour.

Figure 2

Period spectra for the data shown in Figure 1. The three bottom panels represent the amplitude of the spectral components from 10 to 30 hours for the rhythms of feeding activity (A), body temperature (B), and urinary potassium excretion (C). The top three panels show the statistical significance for the period components in the spectra.

Figure 3

Alternative multioscillator models of the circadian timing system. Both represent networks of cellular systems (A, B, C, etc.) which are potentially independent oscillators. Oscillating levels of mediators (ν_a , ν_b , ν_c , etc.) transmit temporal information through the network in a hierarchical (Model A) or non-hierarchical (Model B) fashion. In Model A, the various rhythms are entrained to the environment through the output (p) of a pacemaker (P). Model B has no single pacemaker and thus environmental inputs may directly affect separate oscillatory systems.

ACKNOWLEDGEMENTS

This research was supported by grant NAS9-14249 from the National Aeronautics and Space Administration and grants HL-14150 and HL-13872 from the National Institute of Health. The technical assistance of Ms. Wendy Schmelzer, computer programming assistance of Dr. Janet C. Zimmerman and secretarial assistance of Ms. Margaret Harrigan were gratefully appreciated.

REFERENCES

- Andrews, R.V., and G.E. Folk, Jr. Circadian Metabolic Patterns in Cultured Hamster Adrenal Glands. *Comp. Biochem. Physiol.* 11: 393-409, 1964.
- Aschoff, J. Circadian Rhythms In Man. *Science* 148: 1427-1432, 1965.
- Ashkenazi, I.E., H. Hartman, B. Strulovitz and D. Dar. Activity Rhythms of Enzymes in Human Red Blood Cell Suspensions. *J. Interdisc. Cycle Res.* 6: 291-301, 1975.
- Fowler, D.F. and C.J. Goodnight Neurosecretory Cells - Daily Rhythmicity in Leiobunum longipes. *Science* 152: 1078-1080, 1966.
- Hardeland, R. Circadian Rhythmicity in Cultured Liver Cells. I. Rhythms in Tyrosine Amino-transferase Activity and Inducibility and in [³H] Leucine Incorporation. *Int. J. Biochem.* 4: 581-590, 1973.
- Jacklet, J.W. and J. Geronimo Circadian Rhythm: Population of Interacting Neurons. *Science* 174: 292-302, 1971.
- Moore-Ede, M.C. Control of Circadian Oscillators in Renal Potassium Excretion in the Squirrel Monkey (Saimiri sciureus). Ph.D. Dissertation, Harvard University, 1974.
- Moore-Ede, M.C. and J.A. Herd Renal Electrolyte Circadian Rhythms: Independence from feeding and Activity Patterns. *Am. J. Physiol.* In Press, 1976.
- Moore-Ede, M.C., W.S. Schmelzer, D.A. Kass and J.A. Herd Internal Organization of the Circadian Timing System in Multicellular Animals. *Fed. Proc.* In Press, 1976.
- Rensing, L. Circadian Rhythms of Drosophila Salivary Glands in vivo, in vitro and after ecdysone dosage. *J. Insect Physiol.* 15: 2285-2303, 1969.

Rummel, J., J.K. Lee and F. Halberg Combined Linear-Nonlinear Chrono-
biologic Windows by Least Squares Resolve Neighboring Components in
a Physiologic Rhythm Spectrum. In: Biorhythms and Human Reproduction
(eds. M. Ferin, F. Halberg, R.M. Richart and R.L. Vande Wiele) pp. 53-82.
J. Wiley & Sons, New York, 1974.

Strunwasser, F. The Cellular Basis of Behavior in Aplysia. J. Psychiat.
Res. 8: 237-257, 1971.

Sulzman, F.M., C.A. Fuller and M.C. Moore-Ede Spontaneous Internal
Desynchronization of Circadian Rhythms in the Squirrel Monkey.
(In preparation).

Tharp, G.D. and G.E. Folk, Jr. Rhythmic Changes in the Rate of the Mammalian
Heart and Heart Cells During Prolonged Isolation. Comp. Biochem. Physiol.
14: 255-273, 1965.

Thompson, E.B. and M.E. Lippman Mechanism of Action of Glucocorticoids.
Metabolism, 23: 159-202, 1974.

Fig 1
6

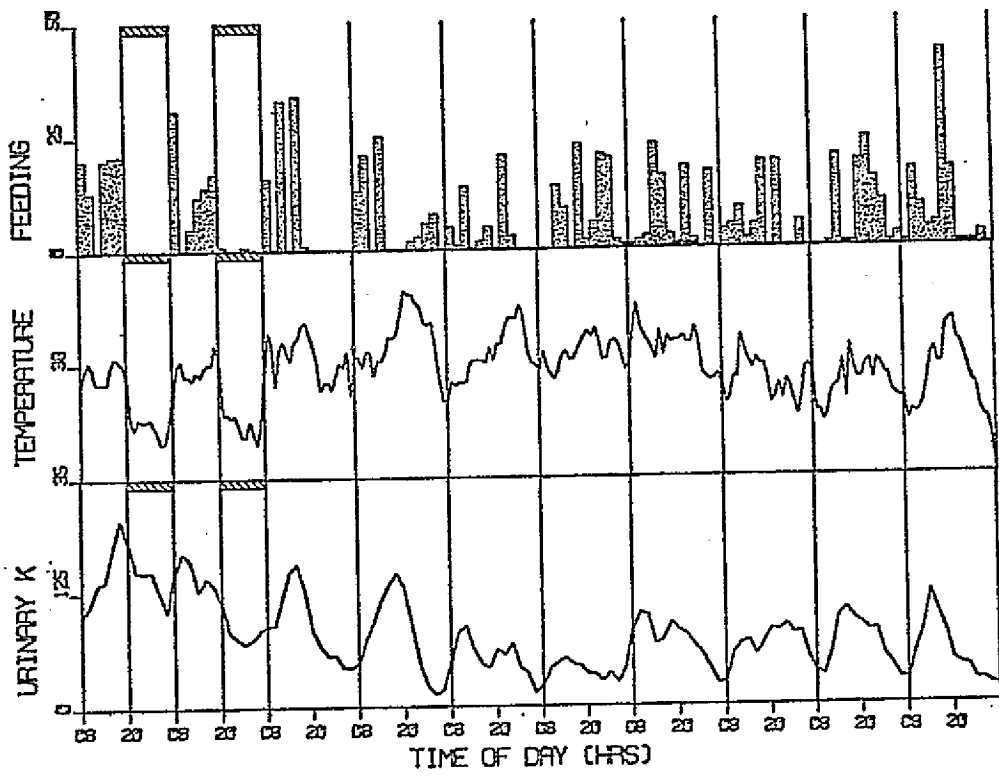

ORIGINAL PAGE IS
OF POOR QUALITY

Fig 2

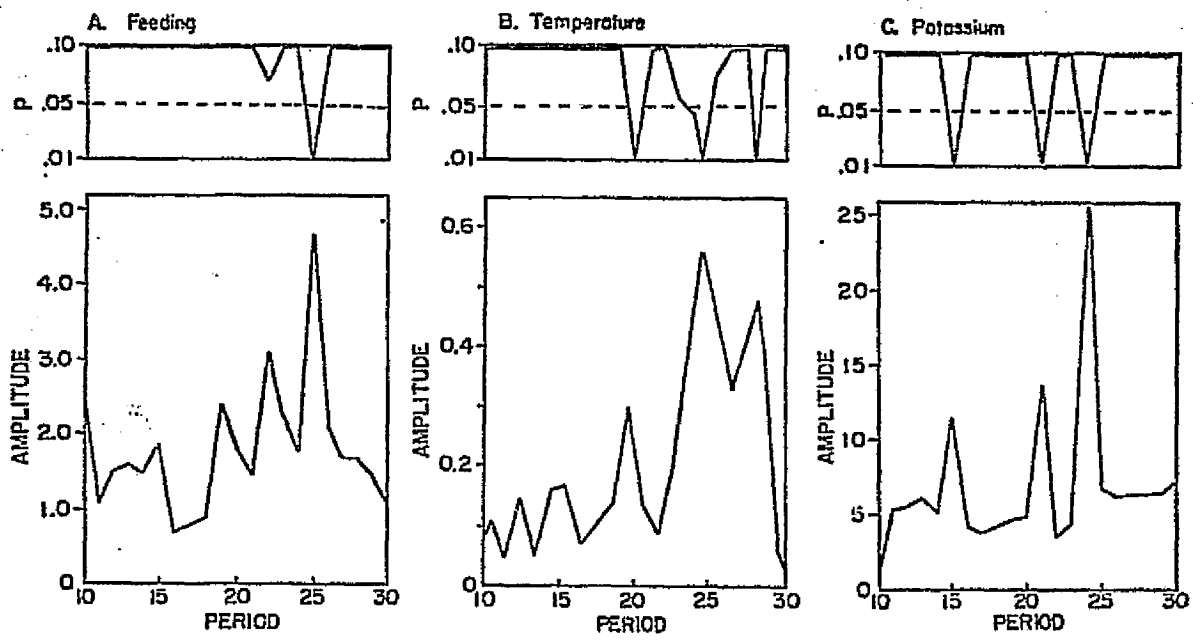

ORIGINAL PAGE IS
OF POOR QUALITY.

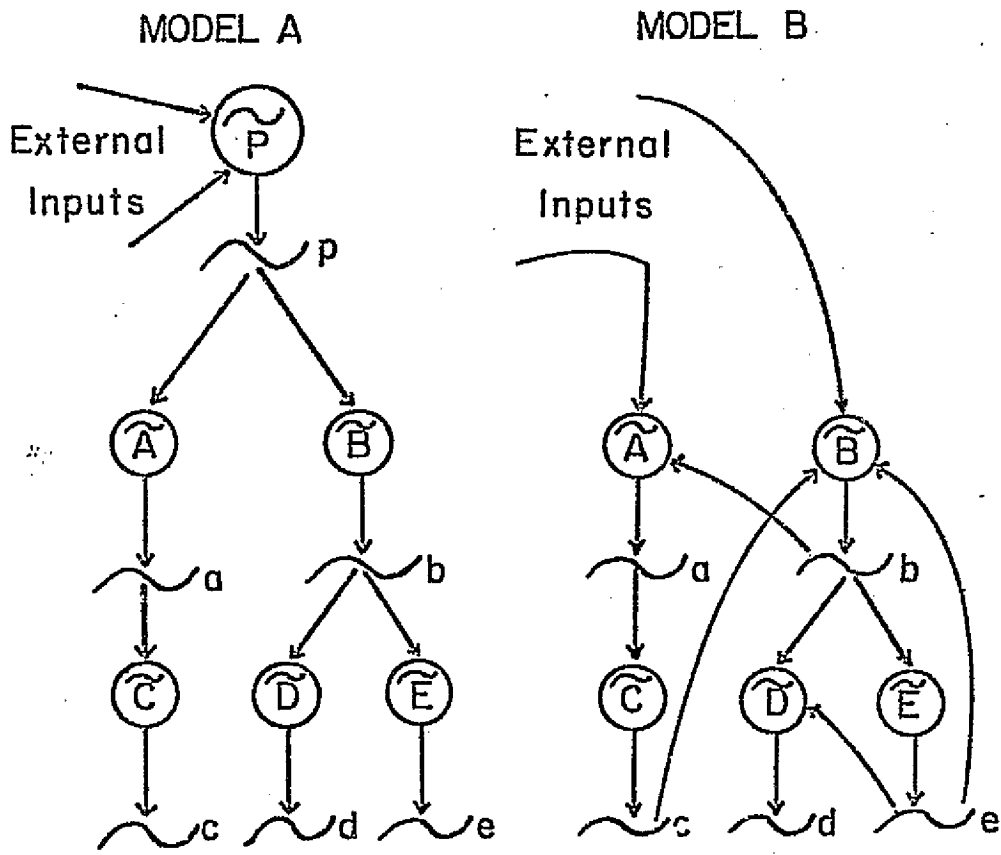

Indicate below the numbers and titles of sessions in which your abstract might be programmed (see Topic Category List); CAREFUL SELECTION IS CRITICALLY IMPORTANT.

1st # 061 Title Adrenal Cortex.....
2nd # 074 Title Chronobiology.....

(See paragraph below for the number of photocopies to be submitted with abstracts.)

Unified
1976 FASEB
Abstract
Form

DO NOT FOLD THIS FORM

Mail to:
Dr. Orr E. Reynolds, Executive Secretary
American Physiological Society
9650 Rockville Pike
Bethesda, Maryland 20014

PRESENTATION PREFERENCE

Preferred choice (CHECK ONE ONLY)

- Poster presentation
 Slide presentation
 Indifferent

16 mm. films (silent or optical sound) are permitted if essential to 10-minute slide session presentation.

MOVIE YES..... NO.....

Submit justification by letter to Society Office, with abstract.

IMPORTANT:

See sample abstracts, typing and mailing instructions on reverse side; use enclosed Check List for preparation of abstract.

SPECIFICITY OF CORTISOL AS AN INTERNAL SYNCHRONIZER OF CIRCADIAN RHYTHMS IN THE SQUIRREL MONKEY. F.M.Sulzman*, W.Schmelzer*, G.A.Fuller, J.C.Zimmerman* and M.C.Moore Ede (SPON: J.A.Herd) Dept. Physiology, Harvard Med Sch, Boston, MA 02115

The circadian timing system in primates consists of an organization of multiple oscillators in various tissues internally synchronized through hormonal coupling. To test the specificity of the circadian rhythm of plasma cortisol concentration as a synchronizing mediator, adrenalectomized, chair-acclimatized squirrel monkeys (*Saimiri sciureus*) were studied. With each monkey isolated in constant light (600 lux), a pulse of 10mg cortisol was administered via a chronically-implanted venous catheter at 08.00 hr daily. The circadian rhythm of renal potassium excretion was entrained to a 24 hr period by the cortisol rhythm, but the circadian rhythms in feeding activity and body temperature were not synchronized by cortisol. These findings demonstrated that the plasma cortisol rhythm acts as an internal synchronizer of renal potassium excretion, but plays no role as a general hormonal coupler of all circadian oscillators. Furthermore, the oscillators which comprise the circadian timing system would appear to be arranged in a hierarchical organization so that the feed-back action of cortisol on the pituitary-adrenal axis does not synchronize the entire circadian system. (Supported by NAS9-14249 and NIH Grants: HL-14150 and HL-13872).

All compounds that are designated by code or initial letters must be identified adequately in the abstract, e.g., MJ-199: 4-(2-isopropylamino-1-hydroxyethyl) methanesulfonamide hydrochloride.

The original typed copy of this abstract form (for reproduction by photo-offset in FEDERATION PROCEEDINGS) must be submitted together with 9 photocopies for all Societies.

ORIGINAL PAGE IS
OF POOR QUALITY

MAILING ADDRESS OF FIRST AUTHOR

Dr. Frank Sulzman, Dept. of Physiology
Harvard Medical School, 25 Shattuck St.
Boston, Massachusetts Zip 02115

Telephone no.: Area Code 617 # 734-3300

Each Abstract Form submitted MUST BE SIGNED by a member of the Society to which the abstract is sent.*

(Member's Signature)

Member's telephone no.: Area Code 617 # 451-0430

x 56

*See the enclosed unified rules for eligibility of papers.

Indicate below the numbers and titles of sessions in which your abstract might be programmed (see Topic Category List); CAREFUL SELECTION IS CRITICALLY IMPORTANT.

1st # 082 Title Temperature Regulation
 2nd # 074 Title Chronobiology.....

(See paragraph below for the number of photocopies to be submitted with abstracts.)

**Unified
1976 FASEB
Abstract
Form**

DO NOT FOLD THIS FORM

Mail to:
 Dr. Orr E. Reynolds, Executive Secretary
 American Physiological Society
 9650 Rockville Pike
 Bethesda, Maryland 20014

MODIFICATION OF THERMOREGULATION IN SQUIRREL MONKEYS IN THE ABSENCE OF CIRCADIAN LIGHT-DARK CYCLES. C.A.Fuller, F.M. Sulzman*, W.S.Schmelzer*, J.C.Zimmerman*, M.C.Moore Ede (SPON: R. Beuwkes) Dept. Physiology, Harvard Med. Sch., Boston, MA 02115

Body temperature in squirrel monkeys (*Saimiri sciureus*) demonstrates a pronounced circadian rhythm which can be entrained by light-dark (LD) cycles (12 hrs light:12 hrs dark) to a period of 24 hours, and persists with a free-running circadian period in constant light (LL). Regulation of colonic temperature (T_R) in chair-acclimatized monkeys in isolation at constant ambient temperature (T_A , $27 \pm 1^\circ\text{C}$) was found to differ between entrained and free-running states both in circadian waveform and in response to a cold pulse of T_A . In LL the circadian waveform of T_R demonstrated an increased period, larger amplitude, and a greater proportion of the cycle above the median temperature than in LD. Differences in T_R regulation between LD and LL were seen in the response to a 6 hour reduction of T_A to $20 \pm 0.5^\circ\text{C}$. This cold pulse produced a $1-3^\circ\text{C}$ fall in T_R in animals who had been in LL for 10 days, but produced no apparent change in T_R in animals in LD. The fall in T_R observed in LL occurred with the onset of the cold pulse and T_R recovered to its previous level when T_A was returned to control levels. These findings indicate that the free-running state is associated with not only a change in the waveform of the rhythm, but also some major alterations in the thermoregulatory capability of the squirrel monkey. (Supported by NAS9-14249 and NIH Grants: HL-14150 and HL-13872).

PRESENTATION PREFERENCE

Preferred choice (CHECK ONE ONLY)

- Poster presentation
- Slide presentation
- Indifferent

16 mm. films (silent or optical sound) are permitted if essential to 10-minute slide session presentation.

MOVIE YES..... NO.....X....

Submit justification by letter to Society Office, with abstract.

IMPORTANT:

See sample abstracts, typing and mailing instructions on reverse side; use enclosed Check List for preparation of abstract.

All compounds that are designated by code or initial letters must be identified adequately in the abstract, e.g., MJ-1999: 4-(2-isopropylamino-1-hydroxyethyl) methanesulfonamide hydrochloride.

The original typed copy of this abstract form (for reproduction by photo-offset in FEDERATION PROCEEDINGS) must be submitted together with 9 photocopies for all Societies.

**ORIGINAL PAGE IS
OF POOR QUALITY**

Each Abstract Form submitted MUST BE SIGNED by a member of the Society to which the abstract is sent.*

MAILING ADDRESS OF FIRST AUTHOR

Dr. Charles A. Fuller, Dept. of Physiology
 Harvard Medical School, 25 Shattuck Street
 Boston, Massachusetts Zip 02115

Telephone no.: Area Code 617..... # 734-3300 x479

Charles A. Fuller
 (Member's Signature)

Member's telephone no.: Area Code 617..... # 734-3300

*See the enclosed unified rules for eligibility of papers.

CIRCADIAN TIMING SYSTEM IN MAN: PHYSIOLOGY AND
PATHOLOGY OF AN ORGANIZATION OF MULTIPLE
SYNCHRONIZED OSCILLATORS

Martin C. Moore Ede

Department of Physiology, Harvard Medical School,
Boston, Massachusetts 02115, U.S.A.

Man, like all other animals, has a circadian timing system which is capable of time measurement in the absence of environmental time cues. This intrinsic timing system plays an important role in the control of both behavioral and physiological functions. This presentation will discuss the evidence which has led us to propose that the circadian system in man is composed of an organization of multiple oscillators in various tissues. In this system, internal synchronization between the various spontaneously oscillating units is maintained through hormonal and neural coupling. It will further be shown how this understanding of circadian organization provides insights into the probable aetiology of functional disorders of the circadian system.

The circadian rhythms which have been demonstrated in several hundred physiological variables in man represent the most easily monitored outputs of the circadian timing system. When circadian rhythms in several diverse physiological variables are monitored simultaneously in any human subject, the monitored circadian rhythms are usually observed to have constant internal phase relationships and identical periods, whether they are synchronized with environmental time cues or free running in constant environmental conditions. Although such internal synchronization could be the result of a single clock driving all circadian oscillations, several lines of evidence indicate that it is instead the product of an internally synchronized multiple oscillator system. For example, spontaneous internal desynchronization has been occasionally reported in man, with the various monitored rhythmic functions oscillating with independent frequencies within the same individual. Similarly, it has been possible to maintain human cells *in vitro* and demonstrate persistent circadian rhythmicity in constant conditions. Neither of these observations is compatible with a single oscillator model.

How then is internal synchronization normally maintained between the various potentially-independent tissue oscillators? Studies using a non-human primate have demonstrated that the rhythmic outputs of certain hormones act as internal mediators (or zeitgebers) synchronizing the circadian oscillators in peripheral tissues. In man, too, there is now good evidence to suggest that the circadian rhythm of plasma cortisol, for example, serves this function in the internal synchronization of circadian rhythms in renal function. Phase-shifting the time of cortisol administration causes a phase shift in the circadian rhythm of potassium excretion in

adrenalectomized patients, and the continuous administration of adrenal steroids with no circadian oscillation results in the appearance of a free running rhythm of urinary potassium excretion, now desynchronized with other circadian functions in the subject. Further evidence indicates that the synchronization process involves a phase control by cortisol which is comparable to the relationship between environmental zeitgebers and the circadian system.

This recognition of the anatomical and physiological nature of the circadian timing system has aided in the analysis of the pathophysiology of the circadian system. Spontaneous internal desynchronization, which has been associated with deteriorations in performance, the symptomatology of 'jet lag', and possibly the reduced life span resulting from repeated exposure to environmental phase shifts, can now be understood as the uncoupling of spontaneous oscillators in the circadian system. We have proposed that this internal desynchronization could be due to circadian arrhythmias in key hormonal mediators.

In an initial evaluation of this hypothesis, we have examined situations where internal desynchronization has been shown to occur. These include exposure to stress, psychopathology and ageing. An investigation of the amplitude of the circadian rhythm in plasma cortisol concentration, a known circadian mediator, indicates that in all these situations there is a tendency for the circadian periodicity to become obscured, thus reducing the mediator's effectiveness in internal synchronization. This proposed mechanism clearly needs further critical analysis, but it indicates the importance of determining the anatomical and physiological organization of the system as a basis for understanding its role as a behavioral determinant, and its pathology.

ORIGINAL PAGE IS
OF POOR QUALITY

Abstract Reproduction Form

TYPE name, address, and telephone number of author who should receive correspondence in Box A and complete Box B.

Telephone (617)-734-3300 X 479 (617)-232-8428
 (Area code) office (Area code) home

A

Name Dr. M.C. Moore-Ede

Address Department of Physiology
Harvard Medical School
Boston, MA 02115

B

Date August 13, 1976

Payment (\$10.00) _____

Check number _____

Purchase order 31349

CHECK Preferred Sub-Specialty Classification:

- Cardiovascular Clinical
- Epidemiology Clinical
- Pharmacology
- Dermatology
- Endocrinology*
- Gastroenterology
- Genetics
- Health Care Research
- Hematology
- Immunology & Conn. Tissue
- Infectious Disease
- Metabolism*
- Oncology
- Pulmonary
- Renal & Electrolyte

*Traditionally, *Endocrinology* has included papers dealing with the thyroid, adrenal and pituitary glands, and gonads, while abstracts dealing with the parathyroids, calcium and phosphorus metabolism, bones, thyrocalcitonin, diabetes, insulin, glucagon, and growth hormone have been considered under *Metabolism*.

CIRCADIAN VARIATION IN INTRAVENOUS POTASSIUM TOLERANCE. Martin C. Moore-Ede, Michael M. Meguid, Garry Fitzpatrick, Margaret R. Ball*, and Caryl M. Boyden*, Department of Surgery, Harvard Medical School at the Peter Bent Brigham Hospital and Department of Physiology, Harvard Medical School, Boston, MA.

The response of five normal men to an intravenous infusion of potassium chloride was compared at midday and midnight. Each subject was maintained on strict supine bedrest with oral intake limited to 100 ml distilled water/hour for the nine hours prior and nine hours post each infusion. 37 mEq potassium chloride (with an added label of 200 μ Ci 42 KCl) in iso-osmolar solution was administered via a central venous catheter over one hour starting either at midday or midnight. Plasma potassium concentration was elevated by 40% more at midnight than at midday, and plasma 42 K activity also rose to a higher level at midnight. These differences were reflected by greater T-wave elevations of the EKG at midnight than at midday. However, urinary potassium excretion (total and 42 K labelled) was higher at midday than at midnight indicating that there was a reduced renal excretory responsiveness to elevations in plasma potassium concentration at midnight as compared to midday. Plasma aldosterone concentration rose during the potassium infusions at both midday and midnight by a similar amount suggesting that adrenal secretory responsiveness to plasma potassium elevations was not a major determinant of the differing renal response. These findings confirm predictions of circadian variations in potassium handling made from our previous studies of endogenous circadian fluxes of potassium between body compartments, and indicate that special caution must be taken in administering potassium infusions at night.

IMPORTANT

The instructions accompanying this form must be followed COMPLETELY for all abstracts which are to appear in CLINICAL RESEARCH. Abstracts which do not conform either will be re-typed by the publisher at a cost of \$15.00 to the author, or rejected.

THIS FORM AS WELL AS THE FORM LETTER OF TRANSMITTAL MUST BE SIGNED BY A MEMBER

