

**NASA TECHNICAL  
MEMORANDUM**

**NASA TM X-73952**

**NASA TM X-73952**

AIRBORNE ANTENNA POLARIZATION STUDY

FOR THE MICROWAVE LANDING SYSTEM

By Melvin C. Gilreath

(NASA-TM-X-73952) AIRBORNE ANTENNA  
POLARIZATION STUDY FOR THE MICROWAVE LANDING  
SYSTEM (NASA) 112 p HC A06/MF A01 CSCL 17G

N77-11266

Unclas  
09531

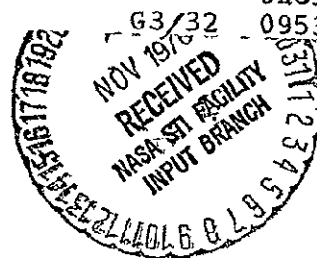

This informal documentation medium is used to provide accelerated or special release of technical information to selected users. The contents may not meet NASA formal editing and publication standards, may be revised, or may be incorporated in another publication.



National Aeronautics and  
Space Administration

Langley Research Center  
Hampton, Virginia 23665

1 Report No NASA TM X - 73952	2 Government Accession No	3 Recipient's Catalog No
4 Title and Subtitle AIRBORNE ANTENNA POLARIZATION STUDY FOR THE MICROWAVE LANDING SYSTEM	5 Report Date	6 Performing Organization Code
	8 Performing Organization Report No	10 Work Unit No 505-07-22-01
7 Author(s) Melvin C. Gilreath	11 Contract or Grant No	13 Type of Report and Period Covered Technical Memorandum
9 Performing Organization Name and Address NASA Langley Research Center Hampton, Virginia 23665	12 Sponsoring Agency Name and Address National Aeronautics and Space Administration Washington, D. C. 20546	14 Sponsoring Agency Code
	15 Supplementary Notes	
16 Abstract An experimental investigation was conducted to determine the feasibility of satisfying the microwave landing system (MLS) airborne antenna pattern coverage requirements for a large commercial aircraft using a single omnidirectional antenna. Omnidirectional antennas having vertical and horizontal polarizations were evaluated at several different station locations on a one-eleventh scale model Boeing 737 aircraft. The results obtained during this experimental program are presented which include principal plane antenna patterns and complete volumetric coverage plots. Typical calculated results obtained from an Ohio State University analytical program are compared with the experimental data.		
<b>ORIGINAL CONTAINS COLOR ILLUSTRATIONS</b>		
17 Key Words (Suggested by Author(s)) Microwave Landing System, Airborne Antennas, Omnidirectional, Directional Antennas, Vertical and Horizontal Polarizations	18 Distribution Statement Unclassified - Unlimited  STAR Category 32 *	
19 Security Classif (of this report) Unclassified	20 Security Classif (of this page) Unclassified	21 No of Pages
		22 Price*

AIRBORNE ANTENNA POLARIZATION STUDY FOR  
THE MICROWAVE LANDING SYSTEM

By Melvin C. Gilreath  
Langley Research Center

SUMMARY

An experimental investigation was conducted to determine the feasibility of satisfying the Microwave Landing System (MLS) airborne antenna pattern coverage requirements for a large commercial aircraft with a single omnidirectional antenna. Omnidirectional antennas having vertical and horizontal polarizations were evaluated at several different station locations on a one-eleventh scale model Boeing 737 aircraft. The results obtained during this experimental program are presented which include principal plane antenna patterns and complete volumetric coverage plots. Typical calculated results obtained from an Ohio State University analytical program are compared with the experimental data.

INTRODUCTION

The airborne antenna system is critical in providing reliable tracking during the operation of the Microwave Landing System (MLS). Factors that must be considered in the airborne antenna design include required pattern coverage, antenna polarization, and location on the aircraft. An investigation has been conducted during which different antenna polarizations (i.e., horizontal and vertical) and locations were studied to determine the feasibility of satisfying the pattern coverage requirements specified by the Federal Aviation Administration (reference 1). This study was performed for the Boeing 737 which is typical of the large aircraft used commercially and is also the type of aircraft being used by NASA Langley's Terminal Configured Vehicle Program. A scale model of the Boeing 737 was used for conducting the experimental measurements. Omnidirectional antennas, as well as directional antennas suitable for providing zone or sector coverage only, were investigated. Antenna radiation patterns and complete volumetric coverage plots are presented for most of the different cases investigated.

In addition to the experimental program conducted at NASA Langley, analytical techniques (references 2 through 5) have been developed at the Ohio State University that are capable of predicting radiation patterns of airborne antennas in an accurate and efficient manner. The numerical solutions can take into account the cockpit/radome section and the vertical stabilizer which have previously been ignored in this work. Computer programs have been delivered to NASA Langley with which complete volumetric patterns can be calculated. In this report, typical calculated principal plane patterns

and volumetric plots are compared with experimental data to demonstrate the capability of the analytical techniques. Reference 5 describes in detail the analytical techniques used and presents a comparison of experimental and analytical results for several different cases not included in this report.

#### AIRBORNE ANTENNA COVERAGE REQUIREMENTS

Detailed specifications have not been established for the MLS airborne antenna coverage requirements, however, the general coverage requirements are for all-around ( $360^\circ$ ) coverage at angles near the horizon (heading) for civilian aircraft; for military aircraft the requirement varies, sometimes being similar to civil aircraft, and in other cases being that forward coverage only is required near the horizon. In addition, for civilian aircraft it is necessary that sufficient coverage be provided below and behind the aircraft for reception during missed approaches. Since no detailed specifications were available when this study began, NASA Langley requested that typical antenna coverage requirements be supplied for use as a guide. These requirements were supplied by the FAA's Microwave Landing System's Airborne Antenna Ad Hoc Committee (reference 1) and are presented in figure 1 and table I. These were generated on an extremely tight time schedule and were intended for use only as a guide for this investigation and should not be considered as the final MLS requirements. The MLS requirements may vary considerably for each different type of aircraft and should be determined on an individual basis. Over specifying of the antenna coverage requirements should not be done since this might needlessly increase the complexity of the antenna design or eliminate antennas that might be acceptable. Figure 1 shows a projection of the solid angle around the aircraft and the areas where coverage is required are designated as zones. For each zone, four characteristics are set forth. The first is a measure of gain referred to isotropic and this is determined for an antenna by computing the percentage of total solid angle in each zone through which the radiation is more than the reference level given in table I.

The second characteristic pertains to pattern ripple and is determined only for Zone A which is treated as a single region for this purpose. Two measures are applied here. The first is ripple fineness which is determined by an examination of the azimuth and elevation plane patterns within the region ( $10^\circ$  increments) and tabulating the smallest angular separation between adjacent maximum and minimum differing by 8 dB or more. The second is a measure of ripple depth and is determined for each of the pattern segments by finding the largest dB difference between any adjacent maximum and minimum which are separated by less than  $5^\circ$ .

The third characteristic is a coarser measure of pattern variation within a zone and is applied to Zones B, C, D<sub>1</sub>, D<sub>2</sub>, and D<sub>3</sub>. It is the pattern "smoothness" characteristic and is measured as 100 percent minus the percentage of the solid angle in each zone through which the radiation is greater than 4 dB different from the average radiation in that zone.



The fourth characteristic pertains to phase center deviation and is determined only for Zone A, treated as a single unit, by calculating the percentage of the solid angle in the zone through which the phase center of radiation is more than 0.7 feet from the physical center of the antenna. In addition, the antenna phase center should be at least 8 feet above the ground at touchdown.

A quality measure for a specific antenna installation is given by the average value of each of the characteristics for all of the applicable zones. This measure is qualitative only and should be used only as a guide for determining which antenna installation to evaluate in more detail.

In selecting antennas for investigation, it should be recognized that there may be different MLS coverage requirements for different aircraft as indicated previously. The actual acceptable limits may vary so drastically from one class of aircraft to another that any one of the following might represent usable coverage for some class of aircraft:

- Coverage Class I - Zone "A" only
- II - Zones "A" and "B" only
- III - Zones "A," "B," and "D" only
- IV - Zones "A," "B," "C," and "D"

#### AIRCRAFT TYPE AND TEST CONFIGURATIONS

Antenna pattern data have been obtained for the Boeing 737 aircraft which is a widely used large commercial air carrier and is also the type of aircraft being used in NASA Langley's Terminal Configured Vehicle (TCV) Program. Full-scale antenna pattern measurements are not practical for large commercial aircraft, therefore, a one-eleventh scale model of the Boeing 737 was used and the measurements were conducted at a scaled-up frequency of 35 GHz. The model was obtained from the Boeing Commercial Airplane Company. It was constructed of fiberglass material and coated at NASA Langley with a silver conducting paint. The flaps were fixed in the retracted position, however, the landing gear was removable to simulate both the stowed wheels and gear-down conditions. Figures 2(a) and 2(b) show the model simulating the gear-down condition in the antenna test chamber.

Measurements were made using both vertically and horizontally-polarized omnidirectional antennas at several locations on the model, with and without landing gear in most cases.

Some aircraft will require coverage in the forward sector (Zone A) only, therefore, antennas that might satisfy this requirement were evaluated in top and bottom forward fuselage locations. Antennas having vertical, horizontal, and circular polarizations were investigated. The actual radome was not simulated on the scale model since all the antennas investigated were not intended for use inside the radome and the radome would have a minimum

influence on the results. Reference 6 presents data obtained by the Boeing Commercial Airplane Company during a study of the MLS airborne antenna/radome problem.

#### ANTENNA TYPES AND LOCATIONS

Two different classes of antennas were considered in this investigation and they were omnidirectional and directional antennas. The omnidirectional antennas were investigated to determine if a single antenna installation could satisfy the MLS requirements on a large commercial jet aircraft. Both vertically and horizontally-polarized antennas were studied. The vertically-polarized antenna was a simple monopole as shown in figure 3, and the horizontally-polarized antenna was an array of slots fed by a coaxial line as shown in figures 4 and 5. The horizontally-polarized antenna design (references 7 through 9) uses six axial slots equally spaced around the outer conductor of the coaxial line. Each slot is excited by a 0.014-inch diameter probe extending from the outer conductor into the inner conductor of the coaxial line. A 0.016-inch diameter hole was drilled approximately 0.024 inches from the center of each slot and centered along the length of the slot to fix the probes in place. These holes were drilled radially through the outer conductor and approximately 0.010 inches into the center conductor. The probes were then inserted into these alignment holes and soldered to the outer conductor in the coaxial line for retaining them in their proper positions. A shorting plug (figure 5) was used to minimize the input VSWR of the antenna at the test frequency of 35 GHz. The six-slot design provided omnidirectional (azimuth plane) coverage to within 1.5 dB when installed on a large ground plane.

The directional type of antenna which is suitable for providing forward sector or single zone coverage only was also investigated since for some classes of aircraft this will be the only requirement. Flush-mounted antennas such as axial and circumferential waveguides having horizontal and vertical polarizations, respectively, were measured. Other antennas included in this class were a monopole with reflectors and an externally-fuselage-mounted circular waveguide capable of radiating horizontal, vertical, or circular polarizations in the forward sector. The circular waveguide was loaded with boron nitride, which has a relatively high dielectric constant ( $\epsilon_r = 4$ ), to reduce the antenna size and keep the protrusion of the antenna above the fuselage quite small. Other types of airborne antennas that might be used for MLS are discussed in reference 10.

Several locations on the aircraft were investigated and these are indicated in figure 6. Locations were selected that appeared to have the greatest possibility of providing the required coverage with a single antenna. Top and bottom fuselage locations as well as top of the vertical stabilizer were used. A rear bottom fuselage location (i.e., station 950) was also selected for providing coverage in the rear sector for missed approaches and other situations requiring coverage in that region if it was determined that antennas at the other locations could not provide this coverage.

## DATA RECORDING AND PROCESSING

The data obtained in this investigation consist of antenna pattern measurements taken over the entire sphere of polar coordinate aspect angles ( $4\pi$  steradians). The coordinate system used is defined in figure 7 and it is assumed the antenna is located at the origin. The X-axis is parallel to the fuselage centerline, with the positive direction toward the nose of the aircraft. The Y-axis is parallel to a line connecting the aircraft wing tips with positive values in the direction of the left wing. The Z-axis is normal to the X-Y plane with the positive direction toward the top of the aircraft. The angles  $\theta$  and  $\phi$  are defined as the elevation and azimuthal angles, respectively.

The antenna patterns were recorded in  $2^\circ$  increments in both  $\theta$  and  $\phi$ . Theta varied from  $0$  to  $180^\circ$  and phi from  $0$  to  $360^\circ$  with a total of 91 records or scans required for each case. A complete recording contains 16,380 data points representing the spherical radiation characteristics of an antenna for a specific set of test conditions (e.g., antenna location, with or without landing gear, etc.). To determine the directivity of the antenna, pattern integration using the measured data is performed over the sphere surrounding the test model. The measured data are scanned in the computer and the maximum amplitude is found and this maximum value is the value representing the calculated maximum directivity. All contour plots and radiation patterns are plotted relative to this maximum directivity value.

Principal plane (i.e., elevation, azimuth, and roll) radiation patterns for each different situation investigated are presented. The volumetric patterns are presented in two forms. The antenna coverage requirements presented earlier gave the required gain levels for the various zones where coverage is necessary. These different gain values were used as the basis for determining the best way to present the data in volumetric form. The first type of presentation is where a single plot is used for displaying all the directivity values that fall within a specified range and since there are six ranges (i.e.,  $\geq 0$  dB,  $\geq -3$  dB,  $\geq -6$  dB,  $\geq -10$  dB,  $\geq -15$  dB,  $\geq -20$  dB), it is necessary to use six plots for presenting all the data. The second form of volumetric pattern utilizes a "false color" plot in which the directivity values that fall within the specified ranges are assigned a color and all the values are displayed on a large screen and photographed to provide a single volumetric pattern complete with all directivity ranges shown. The "false color" plot provides all the data on a single plot for a quick approximate determination of the type of volumetric coverage provided and if a more accurate determination is required, then the six individual plots may be used.

## DATA ANALYSIS

### Omnidirectional Antennas

The data obtained for the omnidirectional antennas at 35 GHz using the one-eleventh scale Boeing 737 model are presented in figures 8 through 10 and tables II through III. Figure 8 presents the volumetric directive gain plots for vertically and horizontally-polarized antennas at different station locations with and without the landing gear. Volumetric plots showing single directivity levels for each case are included in the appendix for a more accurate determination of the coverage provided if desired. Principal plane radiation patterns are presented in figures 9 and 10.

Tables II and III present the data obtained when the radiation patterns were evaluated according to the characteristics specified in the Antenna Coverage Requirements section. Table II gives the percent coverage in each zone, and table III presents the pattern ripple data for Zone A. The pattern "smoothness" characteristic for Zones B, C, D<sub>1</sub>, D<sub>2</sub>, and D<sub>3</sub> was not determined because the percent coverage for some of the zones was low, making the "smoothness" characteristic difficult to obtain, and if obtained, its value was questionable. The fourth characteristic pertaining to phase center deviation for Zone A was not measured since accurate phase measurements are extremely difficult and time consuming to perform at 35 GHz, however, phase data were calculated for some of the cases considered and these results are presented in references 3 and 5.

The locations (figure 6) that were evaluated include stations 220, 250, and 305 on the top fuselage, and stations 222 and 950 on the bottom fuselage, as well as on top-of the vertical stabilizer. The top forward fuselage locations satisfy the requirement that the antenna phase center must be at least 8 feet above ground at touchdown and very good forward coverage is provided that is least affected by the landing gear, engines, and wings.

Figures 8(a) and 8(b) are volumetric plots for a monopole located at station 220 without and with landing gear, respectfully. The plots are almost identical indicating only a small affect on the antenna performance due to the presence of the landing gear. The corresponding principal plane radiation patterns are presented in figures 9(a) and 9(b). These data indicate that very good coverage is provided except in the rear underneath the aircraft which is the area blocked by the aircraft fuselage. Results for the horizontally-polarized antenna at station 220 are given in figures 8(c), 8(d), 9(c), and 9(d). These data again show very little difference between the no landing gear and with landing gear conditions. The horizontally-polarized antenna provides good forward coverage, however, it is not quite equal to the coverage provided by the vertically-polarized antenna. The horizontally-polarized fields are shorted out by the metallic fuselage surface limiting the coverage to sectors above the antenna. The downward slope of the top fuselage at station 220 makes it possible to obtain the good forward down coverage with the horizontally-polarized antenna. As you move farther back on the fuselage, the downward slope becomes smaller and the forward down

coverage for the horizontally-polarized antenna decreases much more rapidly than for the vertically-polarized antenna.

Volumetric plots are presented in figures 8(e), 8(f), 8(g), and 8(h) for the vertically and horizontally-polarized antennas at station 250 slightly off centerline of the top fuselage. The actual aircraft was investigated and due to internal structural interference problems, the antenna could not be mounted exactly on centerline but had to be moved off by 4 to 6 inches, therefore, the experimental scale model measurements were done with the antennas moved off centerline approximately 0.5 inches (full scale = 5.5 inches). This produces the asymmetry in the heading and roll plane patterns as shown in figures 8(e), 8(f), and 8(g). The volumetric plots also show the asymmetry about the nose of the aircraft and this is displayed very well in figure 8(g) in which the color intensity is varied within each directivity range providing a better indication of how the directivity changes within the different ranges. The coverage is still good at this station, however, the forward down coverage has decreased somewhat due to the smaller forward fuselage slope.

Data obtained for station 305 are presented in figures 8(i), 8(j), 9(h), and 9(i) which indicate somewhat better rear coverage, however, the forward down coverage is reduced which is not desirable. Good forward zone coverage is required during the critical final landing phase. This location does not appear suitable for satisfying the MLS requirements.

Data obtained for a bottom forward fuselage location (i.e., station 222) are presented in figures 8(k) through 8(n) and 9(j) through 9(m). Figure 8(k) shows the volumetric plot for the vertically-polarized monopole at station 222 without the landing gear and very good coverage is obtained except in the region above the tail. This is also shown in the principal plane patterns (figure 9(j)) and the heading pattern also indicates the effects in the tail region due to the engines. The landing gear effects are shown in figures 8(l) and 9(k). Severe amplitude variations are produced by the presence of the landing gear and considerable blockage in the rear direction reduces the amount of coverage in the tail region. Data for the horizontally-polarized antenna are presented in figures 8(m), 8(n), 9(l), and 9(m) and show somewhat less coverage without the landing gear than the vertically-polarized antenna. Less coverage along the fuselage for the horizontally-polarized antenna tends to reduce the amount of amplitude variations when the landing gear is present. This location, due to its proximity to the nose landing gear, does not appear to be a suitable location for an omnidirectional antenna. For antennas radiating in the forward direction, it might be an acceptable location since the nose gear would be behind the antenna and would have minimum effect on the antenna performance.

The last location on the fuselage investigated was station 950 on the bottom rear fuselage and the data obtained are presented in figures 8(o) through 8(s) and 9(n) through 9(q). This location was selected for providing coverage in the rear of the aircraft if it was determined that a single omnidirectional antenna could not meet the specified coverage requirements.

Excellent rear coverage is provided as shown by the volumetric plots and principal plane patterns. The landing gear has very little effect on the antenna performance except in the forward nose region where the amplitude is lowered somewhat and the ripple is increased. Figure 8(q) is a volumetric plot for the vertically-polarized monopole in which the color intensity varies within each directivity range to show in more detail how the amplitude changes within each specified range. The data for the horizontally-polarized antenna indicate good coverage is provided, however, coverage in each zone is somewhat less than that provided by the vertically-polarized antenna.

In addition to the fuselage locations, measurements were obtained for a monopole mounted on top of the vertical stabilizer. Elevation plane patterns were measured for different azimuth angles and some typical patterns are shown in figure 10. Coverage below the aircraft directly off the nose is reduced by blockage of the fuselage. As the angle off the nose increases, the down coverage improves, however, considerable amplitude variations occur especially above the nose of the aircraft due to reflections off the fuselage. These rapid amplitude variations could cause serious problems for the MLS. The vertical stabilizer location would require long cable runs from the antenna to the onboard electronics which could produce unacceptable transmission losses. This location could also pose a more difficult retrofit problem than some of the other MLS locations investigated making it a less desirable location.

The data presented in tables II and III give the percent coverage (i.e., directivity values  $\geq$  specified value) in each zone and ripple fineness and ripple depth for Zone A for the different test conditions. As indicated in table II, neither the vertically-polarized monopole nor the horizontally-polarized slot antenna completely satisfies the coverage requirements specified. The coverage provided by the monopole is considerably greater for all cases investigated. The top forward fuselage locations (i.e., stations 220 and 250) provide good forward coverage with limited coverage in Zones C, D, E, and F. The coverage is improved at station 222 on the bottom forward fuselage, however, this location does not satisfy the 8-foot minimum height at touchdown requirement and considerable pattern perturbations are produced by the landing gear and engines making this an undesirable location for an omnidirectional antenna. The pattern ripple in Zone A is greatest for this location as indicated in table III.

The data obtained during this investigation indicate that the specified coverage requirements cannot be satisfied with a single omnidirectional antenna either vertically or horizontally polarized. If the specified coverage is to be obtained for large commercial aircraft, two antennas with some type of switching between them would be necessary. The two locations chosen for the antennas on the NASA TCV aircraft were stations 250 on the top fuselage, and 950 on the bottom fuselage. Figure 11 shows the principal plane patterns for two vertically-polarized monopoles at these station locations on the one-eleventh scale model Boeing 737. The coverage provided is very good as indicated in figure 11 and table II when the coverage for the two antennas is combined. These locations were chosen based on coverage provided and ease of installation.

A comparison of experimental data obtained in this investigation and analytical results from the Ohio State University program (reference 5) is made in figures 12 and 13. Figure 12 shows the elevation, heading, and roll patterns for a  $\lambda/4$  monopole mounted at station 220 on top of a Boeing 737 aircraft. The measured volumetric plot is shown in figure 13(a), and the comparable calculated plot is presented in figure 13(b). The results show excellent agreement demonstrating the capability of the analytical techniques. Reference 5 describes the analytical techniques used in obtaining these results and presents an extensive comparison of experimental and analytical results for many of the cases investigated in this study plus data for several other cases not included in this report. With the analytical results verified with experimental data, they can be used to do a parametric antenna design study of other large commercial aircraft and in a much more efficient way than the usual scale model approach.

### Directional Antennas

Some aircraft will require antenna pattern coverage only for the forward zone (i.e., Zone A), therefore, typical antennas that might satisfy this requirement were investigated at stations 220 (top) and 222 (bottom) on the Boeing 737 scale model. Antennas having vertical, horizontal, and circular polarizations were evaluated. Flush-mounted axial and circumferential Ka-band rectangular waveguides were evaluated and the principal plane results for the top fuselage location are presented in figures 14 and 15. The vertically-polarized circumferential waveguide provides very good forward elevation plane coverage as shown in figure 14(a). Figure 14(b) shows the corresponding heading pattern and again good coverage for Zone A is provided. Principal plane patterns for the horizontally-polarized axial waveguide are shown in figure 15. The elevation plane pattern (figure 15(a)) shows poor coverage in the forward direction with the value off the nose approximately 12 dB below the maximum gain of the antenna which occurs at approximately  $60^\circ$  above the nose. The elevation plane coverage for the horizontally-polarized axial waveguide is determined primarily by the forward slope of the fuselage. The heading pattern shown in figure 15(b) indicates good coverage. The pattern amplitudes for the elevation and heading patterns should be the same directly off the nose, however, the heading pattern levels are a few dB higher than the corresponding elevation patterns. The patterns are intended only to show the angular coverage provided for the different antennas.

The vertically-polarized monopole with three reflectors for producing a forward-looking radiation pattern was also evaluated and these results are presented in figure 16. The elevation plane pattern shows very good coverage with a 4 to 5 dB amplitude variation in the region above the nose. Coverage in the heading plane is also good as shown in figure 16.

A circular waveguide with a polarizer for providing vertical, horizontal, or circular polarization was evaluated and these results are given in figure 17. The waveguide was loaded with boron nitride to reduce the size.

REPRODUCTION OF THE  
ORIGINAL DOCUMENT

It was mounted on the top fuselage surface at station 220 to produce maximum radiation in the forward direction. The elevation and heading patterns for the different polarizations are presented in figure 17. Figure 17(a) shows large pattern variations in the region above the aircraft nose due to reflections off the top of the forward fuselage. Figure 17(b) shows that very good coverage is provided with horizontal polarization without the amplitude variations present in the elevation plane for vertical polarization, however, the down coverage is somewhat less for horizontal. The coverage provided with circular polarization is shown in figure 17(c) and appears to be an average of the horizontal and vertical components as one would expect.

Similar measurements were conducted for the same antennas at station 222 on the bottom fuselage and these results are presented in figures 18 through 21. Figure 18 shows the principal plane patterns for the vertically-polarized circumferential waveguide and both the elevation and heading patterns exhibit small amplitude variations due to reflections off the nose gear. The coverage above the nose is limited due to the small upward slope of the bottom fuselage.

Figure 19 gives the patterns for the horizontally-polarized axial waveguide and as shown in the elevation plane, coverage directly off the nose is approximately 20 dB below the maximum and very little coverage above the nose is provided. Considerable amounts of amplitude variations produced by reflections off the nose landing gear are present in the heading pattern.

The monopole with reflectors was also measured and the data obtained are presented in figure 20. Good forward coverage is provided as indicated in both the elevation and heading patterns and because the maximum energy is directed forward away from the nose landing gear, its presence has very little influence on the antenna performance.

Data obtained for the forward-looking, surface-mounted circular waveguide are presented in figure 21. Patterns were measured for vertical, horizontal, and circular polarizations. Coverage above the nose was better for vertical polarization as shown in the elevation pattern of figure 21(a). The maximum directivity occurs at approximately 5° above the nose of the aircraft. For horizontal polarization, the maximum directivity occurs at approximately 20° below the nose and the level directly off the nose is down approximately 5.5 dB, as shown in the elevation pattern of figure 21(b). Figure 21(c) indicates good coverage is obtained with circular polarization, however, the amplitude variations are somewhat greater than for the other polarizations.

The results of an evaluation to determine the percent coverage, ripple fineness, and depth for Zone A are presented in table IV for the monopole with reflectors and circular waveguide antennas. The evaluation was not done for the axial and circumferential waveguides due to insufficient pattern data. For those cases evaluated, the horizontally-polarized circular waveguide provided the lowest Zone A coverage for both top and bottom locations. The circularly-polarized antenna provided the most coverage of



Zone A at both locations. The vertically-polarized circular waveguide at the top antenna location was the only antenna having large pattern variations and these range from approximately 10 to 36 dB over a small region above the aircraft nose. It appears from the measured data that good forward zone coverage can be obtained by using antennas similar to those evaluated or other directional antennas such as mitered waveguide or mitered half-height horn antennas.

#### CONCLUDING REMARKS

Results have been presented of an experimental investigation to determine the feasibility of satisfying the MLS airborne antenna pattern coverage requirements with different antenna polarizations and locations for the Boeing 737 aircraft.

The data presented indicate that the specified MLS airborne antenna coverage requirements for large commercial aircraft cannot be satisfied with a single omnidirectional antenna, either vertically or horizontally polarized. It appears that in order to provide coverage that might be acceptable would require at least two antennas with the capability of switching between them. Stations 250 on the top fuselage and 950 on the bottom fuselage were selected for the antenna installations on the NASA TCV Boeing 737 aircraft. Experimental data obtained for vertically-polarized monopoles at these selected locations on the one-eleventh scale model of the Boeing 737 indicate very good coverage can be provided with two antennas.

The data obtained during this investigation indicate that the vertically-polarized monopole provides more coverage than the horizontally-polarized coaxial slot-fed antenna measured at the same station location.

The directional antennas investigated provided better forward zone coverage from the top forward fuselage location. This was primarily due to the more downward slope of the fuselage over the cockpit area.

A comparison of the experimental data obtained in this investigation with analytical results from the Ohio State University program showed very good agreement. This experimental verification demonstrated the capability of the analytical techniques and provides a tool for performing a parametric antenna design study of other large commercial aircraft in an efficient manner.

REPRODUCIBILITY OF THE  
ORIGINAL PAGE IS POOR

#### REFERENCES

1. Memorandum dated 12-17-74 to William F. Crowell, NASA Langley, "Suggested Revisions to NASA Langley Airborne Antenna Research Task," from MLS Airborne Antenna Ad Hoc Committee.
2. Burnside, W. D.; Gilreath, M. C.; Marhefka, R. J.; and Yu, C. L.: A Study of KC-135 Aircraft Antenna Patterns. IEEE Trans. on Antennas and Propagation, Vol. AP-23, No. 3, May 1975, pps. 309-16.
3. Yu, C. L.; and Burnside, W. D.: MLS Airborne Antenna Research. The Ohio State University ElectroScience Laboratory, Semi-Annual Report 2902-22, May 1975, prepared under NASA Grant Number NGL 36-008-138.
4. Yu, C. L.; and Burnside, W. D.: Research on MLS Airborne Antenna. The Ohio State University ElectroScience Laboratory, Semi-Annual Report 2902-23, April 1976, prepared under NASA Grant Number NGL 36-008-138.
5. Yu, Chong L.; and Burnside, Walter D.: Volumetric Pattern Analysis of Fuselage-Mounted Airborne Antennas. The Ohio State University Electro-Science Laboratory, Technical Report 2902-24, April 1976, prepared under NASA Grant Number NGL 36-008-138.
6. Fries, James R.; and Stapleton, Brian P.: MLS Airborne Antenna/Radome Study. The Boeing Commercial Airplane Company, Report No. D6-42598, June 30, 1975, prepared under Vitro Subcontract VL-SC-1153, DOT Contract FA7/2-WA-3010.
7. Silver, Samuel: Microwave Antenna Theory and Design. McGraw-Hill Book Company, Inc., 1949, pps. 305-308.
8. Jasik, Henry: Antenna Engineering Handbook. McGraw-Hill, Inc., 1961, pps. 26.4 to 26.6.
9. Ferris, Joseph E.: Dual Band Airborne Antenna Study. U.S. Army Electronics Command Research and Development Technical Report ECOM-73-0337-F, October 1974 (The University of Michigan Radiation Laboratory Report No. 012126-1-F prepared under Contract DAAB07-73-C-0337 for U.S. Army ECOM).
10. Ploussious, George: Circular Polarization Analysis for the Microwave Landing System (MLS). U.S. Army Electronics Command Research and Development Technical Report ECOM-75-0801-F, February 1976, prepared by Meyer Associates, Inc., under Contract DAAB07-75-C-0801.

TABLE I  
AIRBORNE ANTENNA GAIN REQUIREMENTS

ZONES	GAIN (RELATIVE TO ISOTROPIC)		
	<u>CIVIL</u>	<u>MILITARY</u>	
		HIGH PERF*	LOW PERF
A <sub>1</sub> , A <sub>2</sub> , A <sub>3</sub> , A <sub>4</sub>	0 dB	0 dB	0 dB
B	-3 dB	-3 dB	-3 dB
C	-6 dB	-6 dB	-6 dB
D <sub>1</sub> , D <sub>2</sub> , D <sub>3</sub>	-10 dB		-6 dB
E	-15 dB		
F	- 15 dB		

\*SUPERSONIC; LOW PERF IS SUBSONIC

TABLE II  
ANTENNA PATTERN COVERAGE

<u>ANTENNA TYPE AND LOCATION</u>	<u>ZONES (PERCENT COVERAGE)</u>					
	<u>A</u>	<u>B</u>	<u>C</u>	<u>D</u>	<u>E</u>	<u>F</u>
<u>I. Station 220</u>						
Monopole <sup>a</sup>	99.5	92.2	60	40	16.7	0
Monopole <sup>b</sup>	99.3	92.8	60	40	16.7	0
HP Antenna <sup>a</sup>	80	64.4	20	4	6.67	0
HP Antenna <sup>b</sup>	80	64.4	20	4	6.67	0
<u>II. Station 250 (Off Centerline)</u>						
Monopole <sup>a</sup>	90	84	74	46	10	0
Monopole <sup>b</sup>	90	84	60	40	10	0
HP Antenna <sup>b</sup>	59	72.7	30	12	0	0
<u>III. Station 305</u>						
Monopole <sup>a</sup>	72	82.2	70	52	31.7	0
HP Antenna <sup>b</sup>	46	53.7	36	24	0	0
<u>IV. Station 222</u>						
Monopole <sup>a</sup>	99.5	96.9	94.6	76	80	100
Monopole <sup>b</sup>	98.6	97.5	55.8	60	88.3	100
HP Antenna <sup>a</sup>	77	69.5	58	42	76.7	100
HP Antenna <sup>b</sup>	74	67.7	38	36	85	100
<u>V. Station 950</u>						
Monopole <sup>a</sup>	58	67.7	100	100	100	83.3
Monopole <sup>b</sup>	36	62.4	100	100	100	83.3
HP Antenna <sup>a</sup>	24	45.4	79	88	100	56.7
HP Antenna <sup>b</sup>	20	61.8	80	88	100	56.7

a - without landing gear  
b - with landing gear

TABLE III  
PATTERN RIPPLE FINENESS AND RIPPLE DEPTH FOR ZONE A

ANTENNA TYPE AND LOCATION	RIPPLE FINENESS <sup>a</sup>	RIPPLE DEPTH <sup>a</sup>
I. <u>Station 220</u>		
Monopole	< 8 dB	4 dB - 4° Separation
HP Antenna	< 8 dB	< 2 dB
II. <u>Station 250</u> (Off Centerline)		
Monopole	< 8 dB	2.5 dB - 2° Separation
HP Antenna	< 8 dB	< 1 dB
III. <u>Station 305</u>		
Monopole <sup>b</sup>	< 8 dB	2 dB - 3° Separation
HP Antenna	< 8 dB	< 1 dB
IV. <u>Station 222</u>		
Monopole	6° - 10 dB	8 dB - 4° Separation
HP Antenna	< 8 dB	4 dB - 2° Separation
V. <u>Station 950</u>		
Zone A evaluation not performed for rear sector location		

a - Ripple fineness and ripple depth values given for those values that satisfy minimum coverage requirements (i.e.,  $\geq 0$  dB) in Zone A

b - Without landing gear

REPRODUCIBILITY OF THIS ORIGINAL PAGE IS POOR

TABLE IV  
DIRECTIONAL ANTENNA PATTERN COVERAGE AND PATTERN RIPPLE FOR ZONE A

ANTENNA TYPE AND LOCATION	POLARIZATION	% COVERAGE	RIPPLE FINENESS	RIPPLE DEPTH
I. <u>Station 220</u>				
Monopole with Reflectors	Vertical	94	< 8 dB	3° Separation upper elevation
Circular Waveguide	Vertical	96	10 - 36 dB	
Circular Waveguide	Horizontal	80	< 8 dB	
Circular Waveguide	Circular	99	< 8 dB	
II. <u>Station 222</u>				
Monopole with Reflectors <sup>a</sup>	Vertical	92	< 8 dB	
Monopole with Reflectors	Vertical	92	< 8 dB	
Circular Waveguide	Vertical	93	< 8 dB	
Circular Waveguide	Horizontal	70	< 8 dB	
Circular Waveguide	Circular	95	< 8 dB	

a - Without landing gear

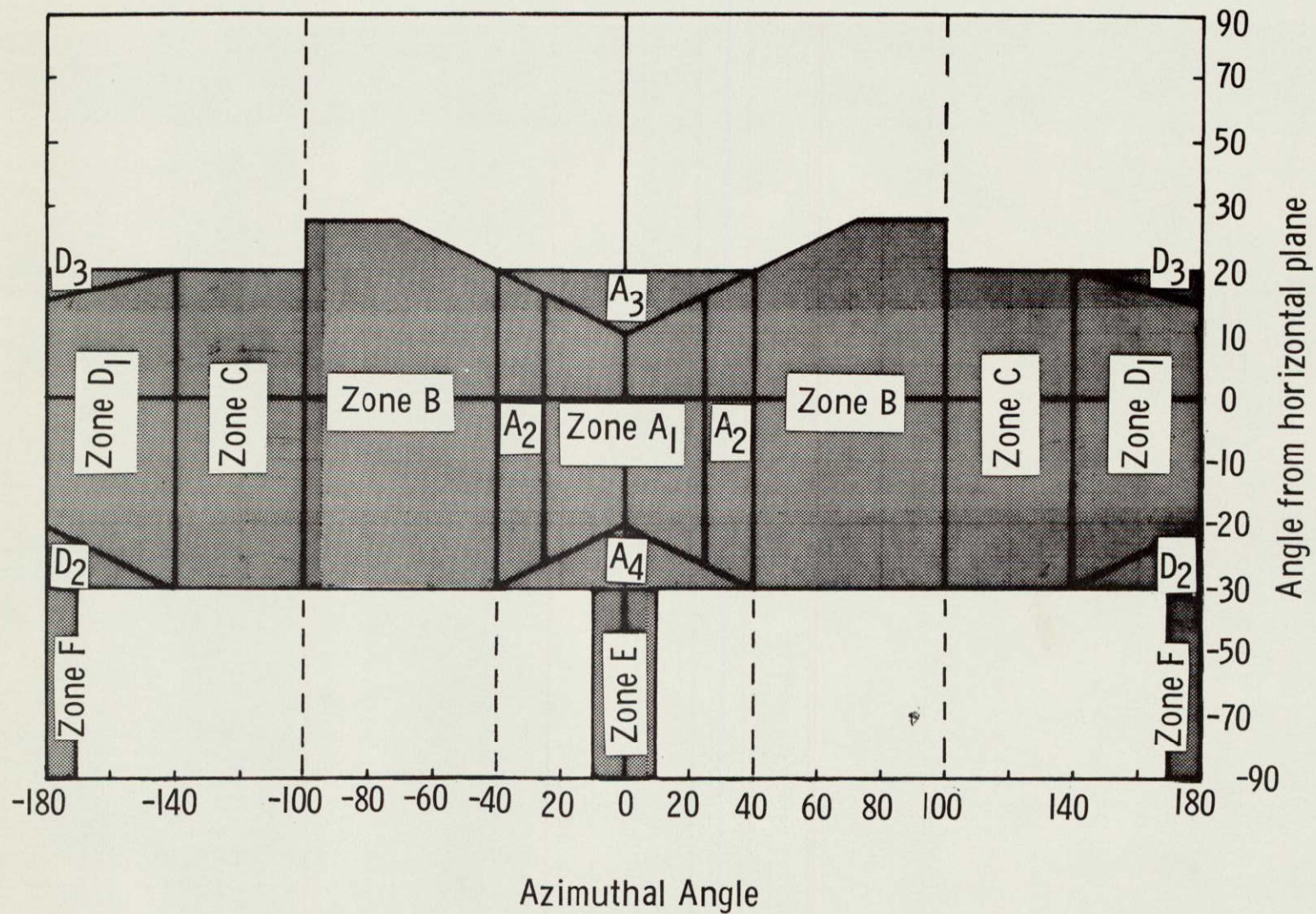
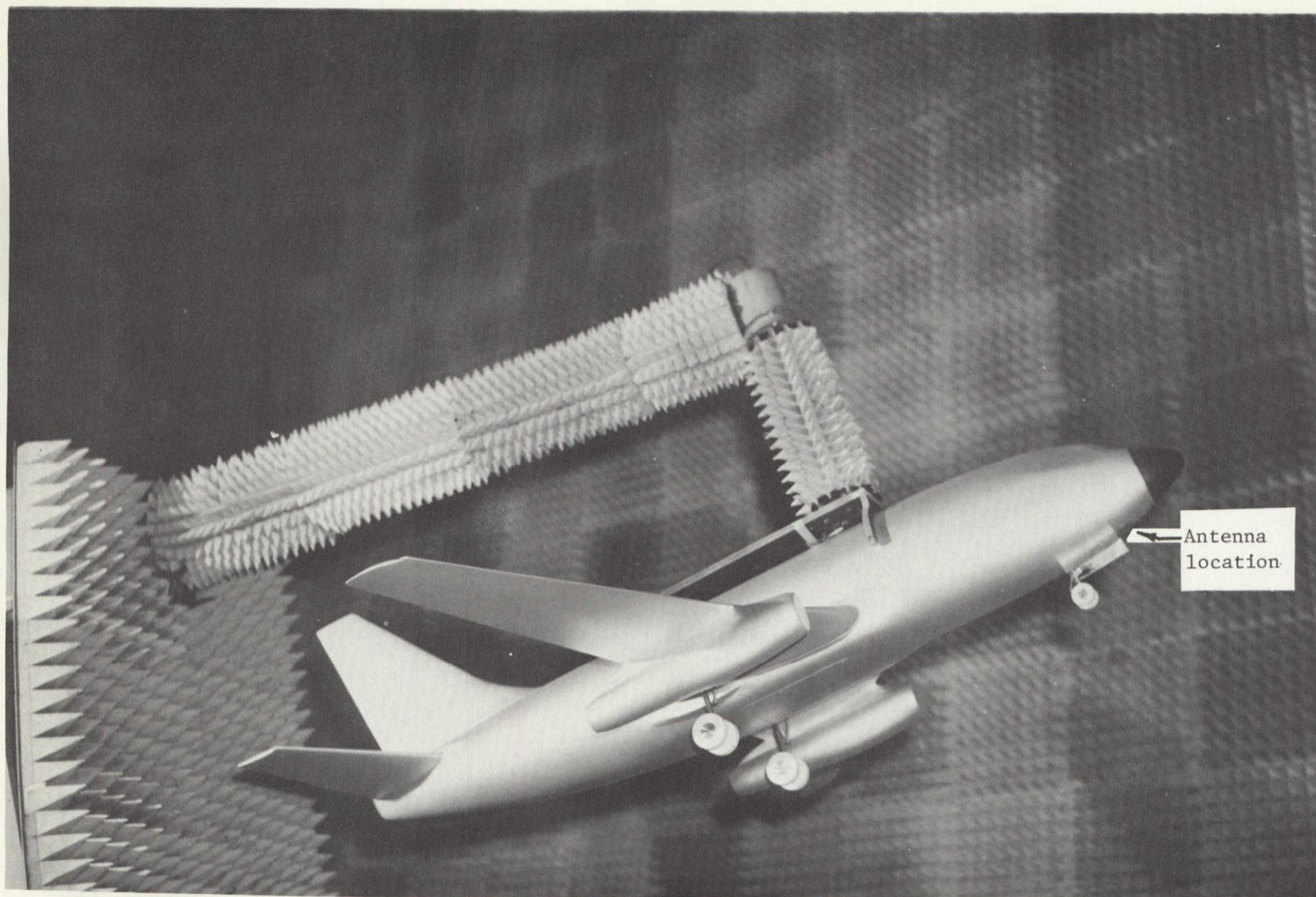

Figure 1.-Airborne antenna coverage zones.





(a) Sideview

Figure 2.- One-eleventh scale model of a Boeing 737 in RF Anechoic Chamber.

REPRODUCIBILITY OF THIS  
ORIGINAL PAGE IS POOR



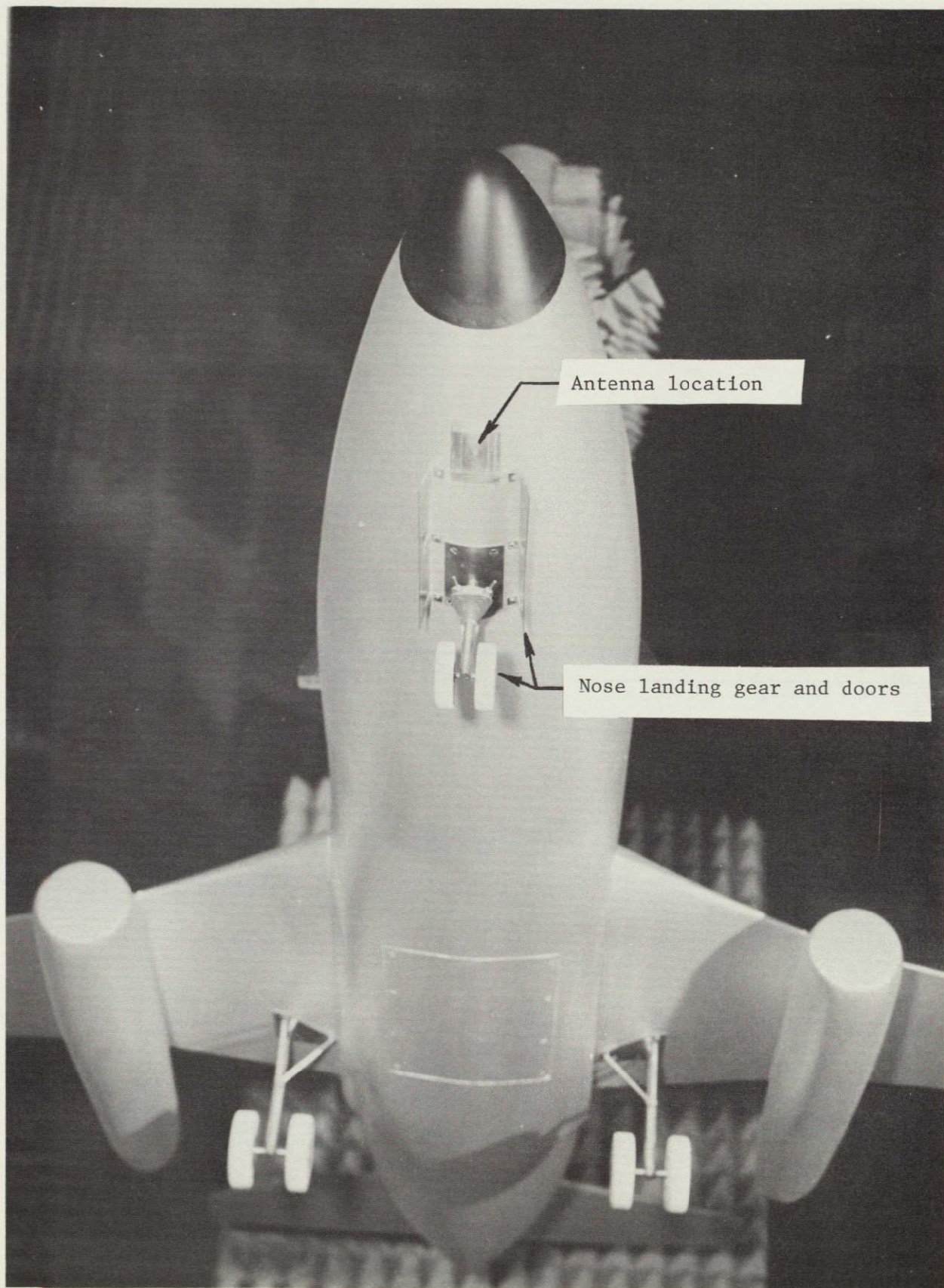

NASA  
L-74-7897

(b) Bottom view

Figure 2.- Concluded.



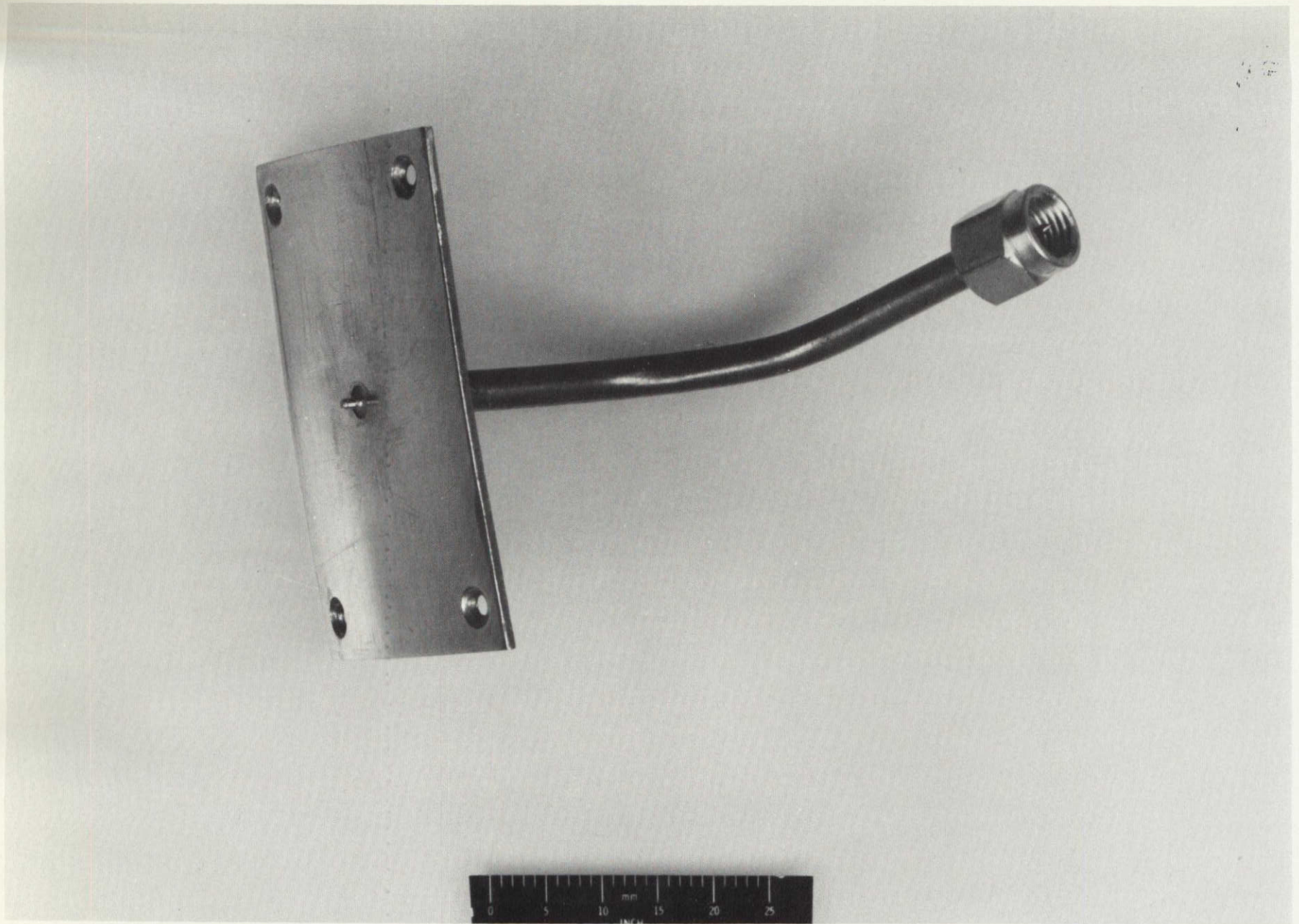
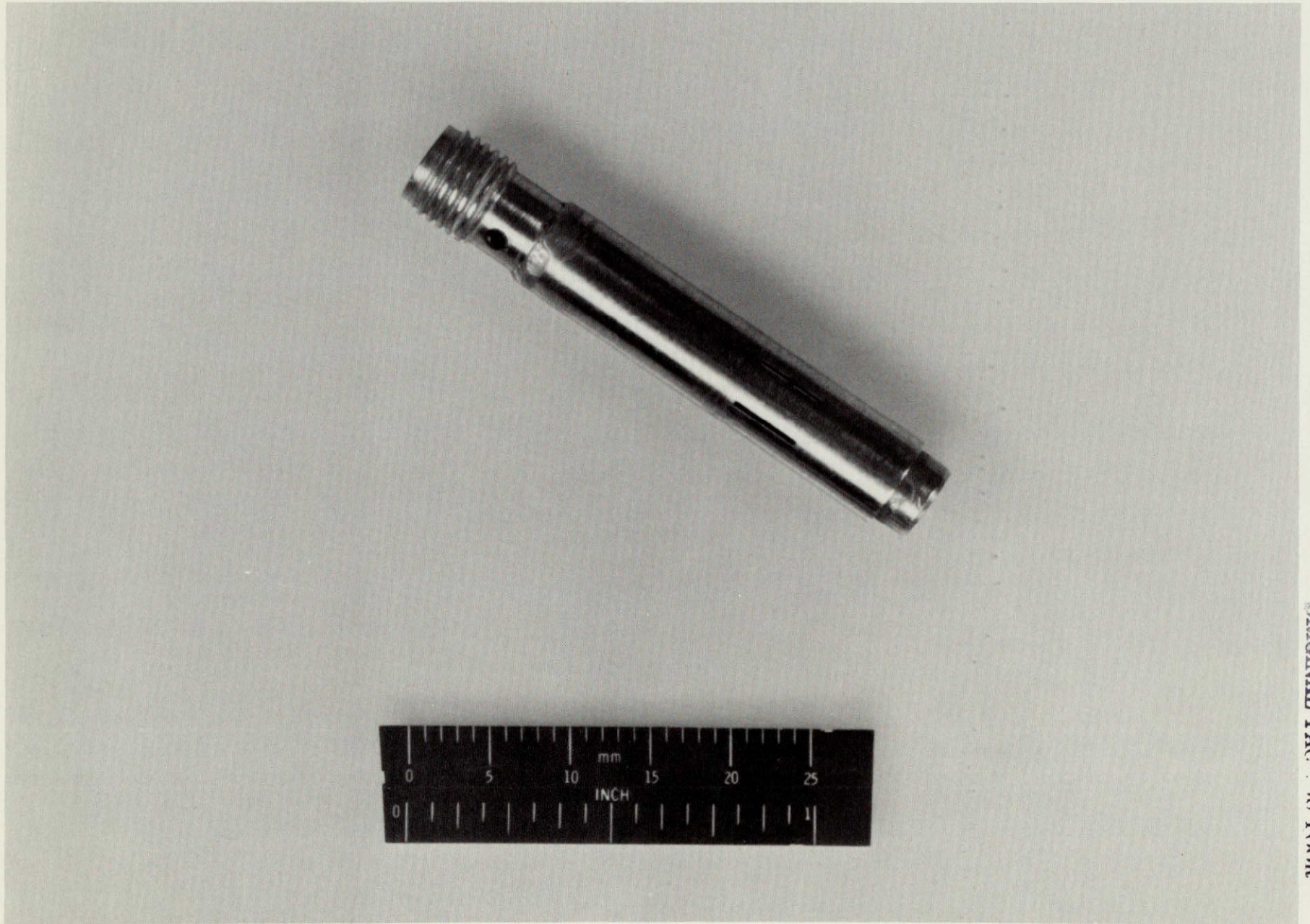

Figure 3.- Quarter wavelength monopole at 35 GHz with mounting plate for Boeing 737 scale model.





REPRODUCIBILITY OF THE  
ORIGINAL PAGE IS POOR

Figure 4.- Horizontally polarized coaxial fed slot antenna.

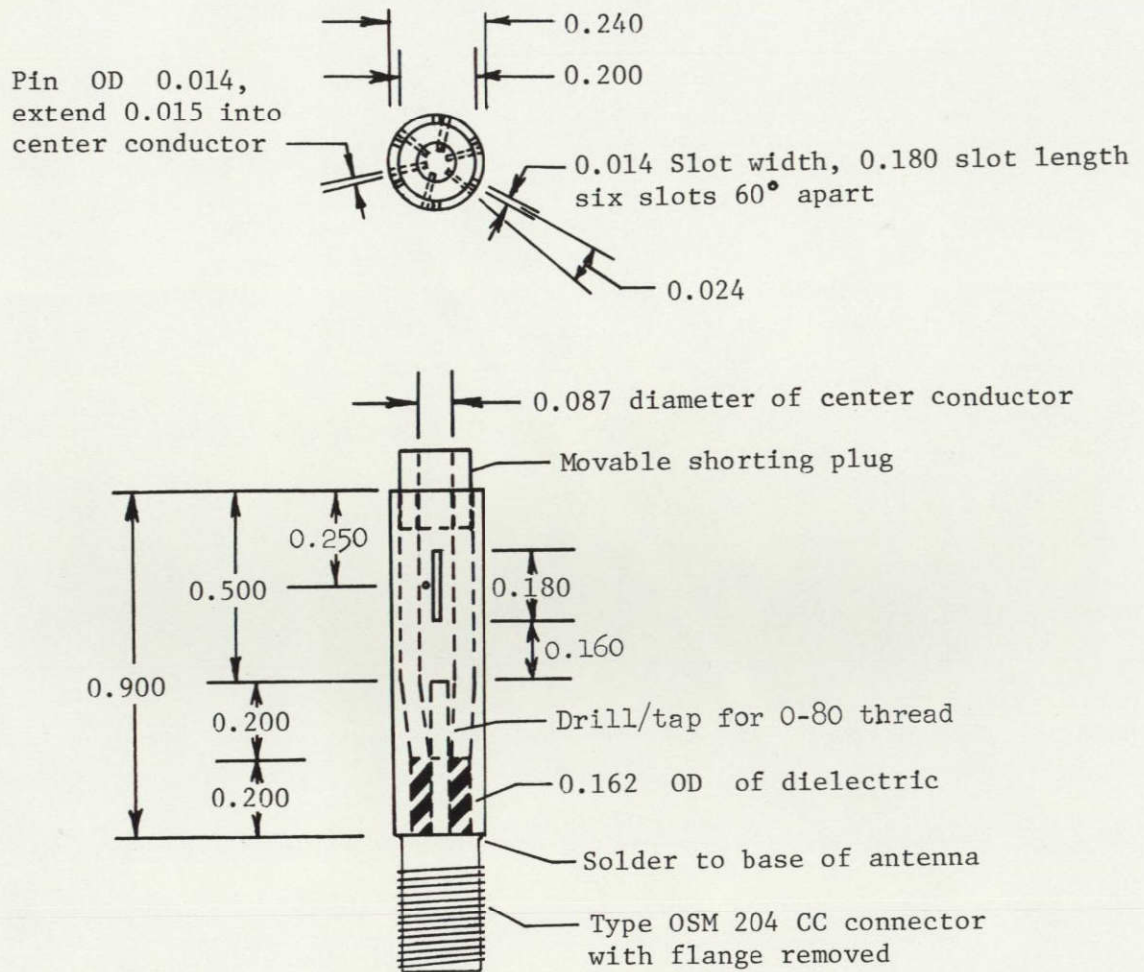

All dimensions are in inches

Figure 5.- Drawing of horizontally polarized coaxial fed slot antenna.

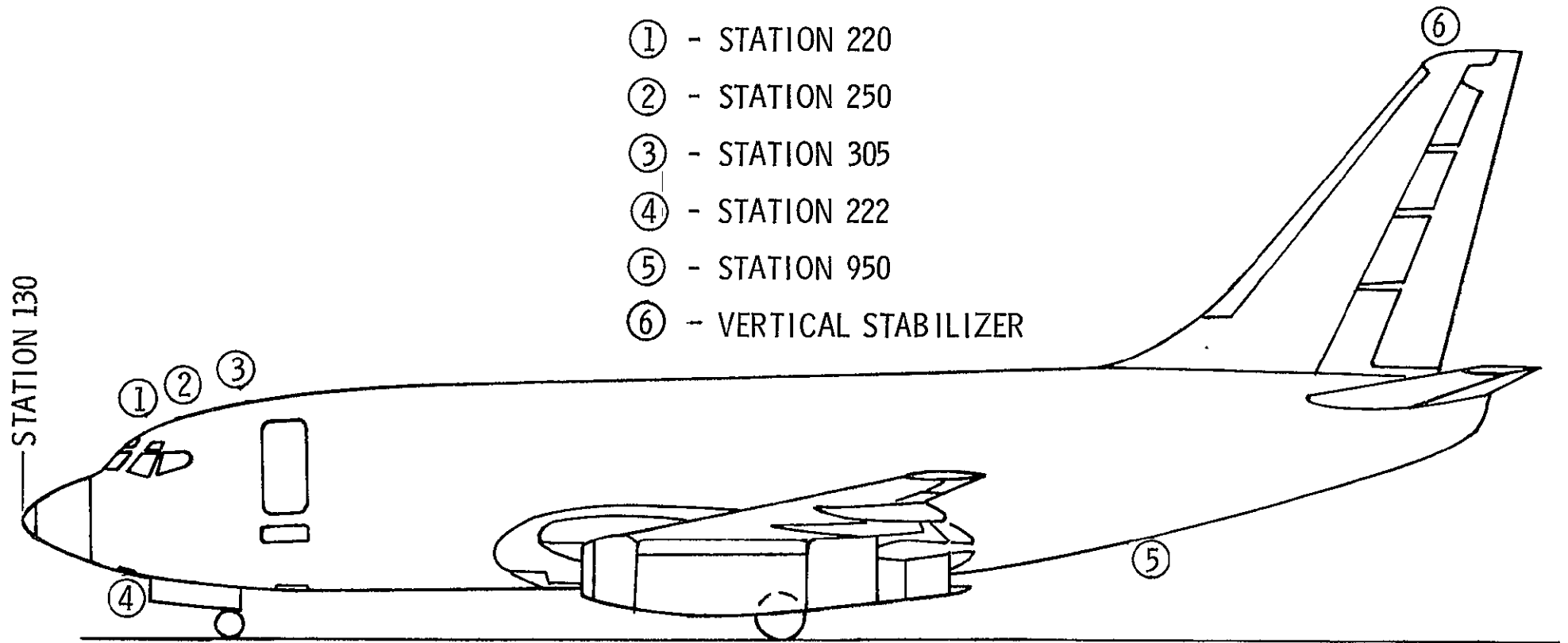

Figure 6.- Antenna locations investigated for the Boeing 737.

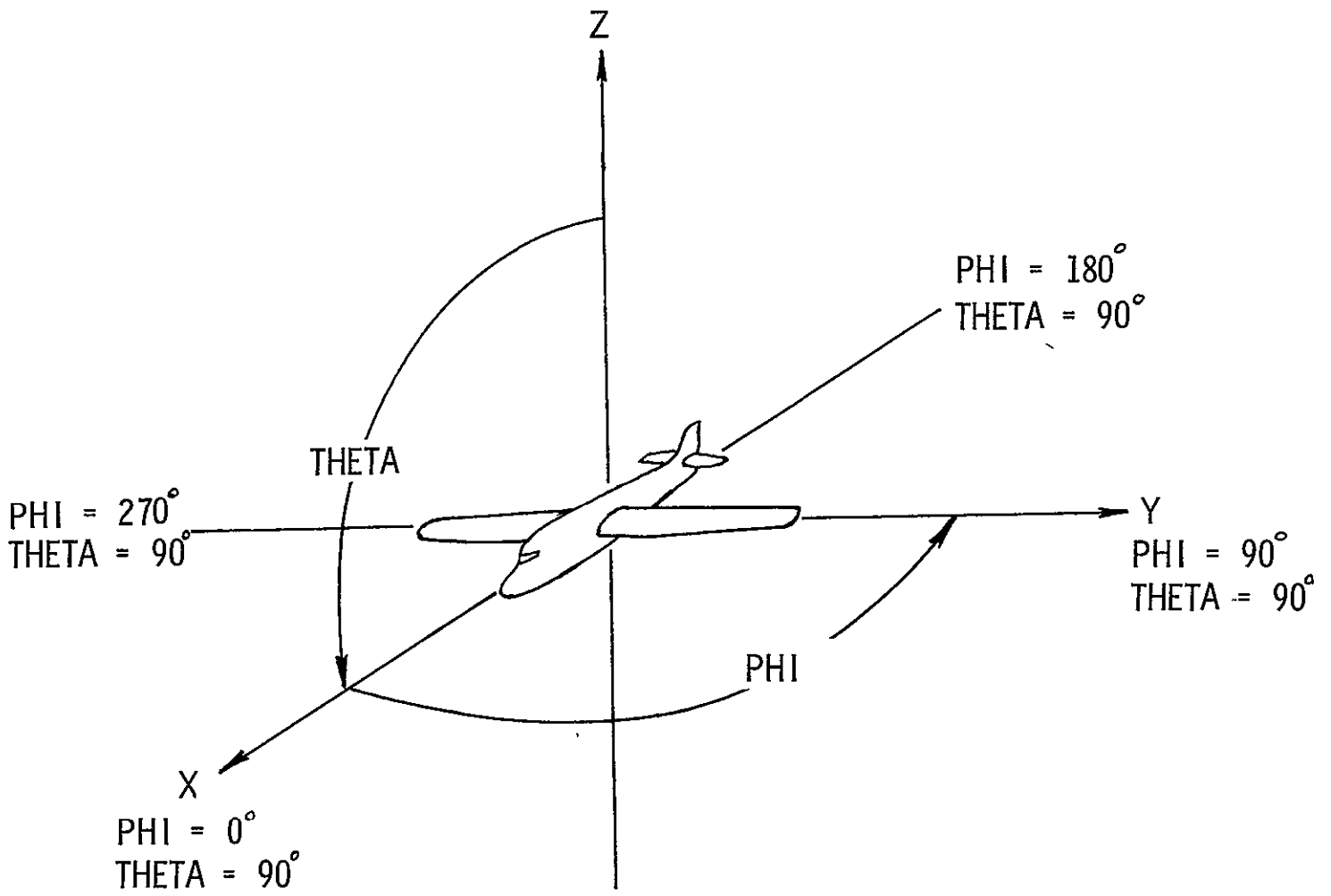
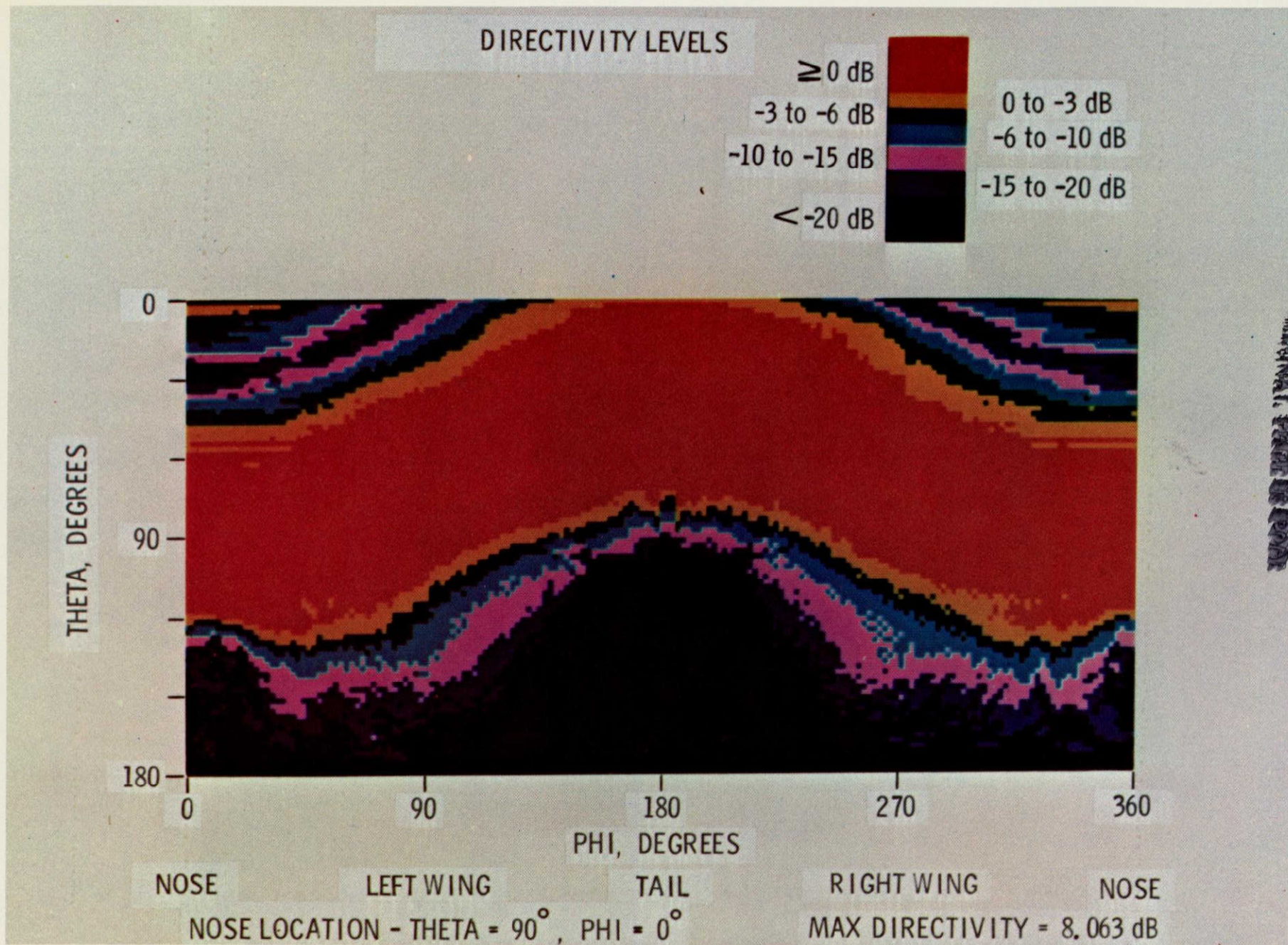

Figure 7.- Coordinate system used for experimental measurements.





(a) Monopole at station 220 on top fuselage.

Figure 8. - Volumetric plots for omnidirectional antennas on one-eleventh scale model of a Boeing 737.



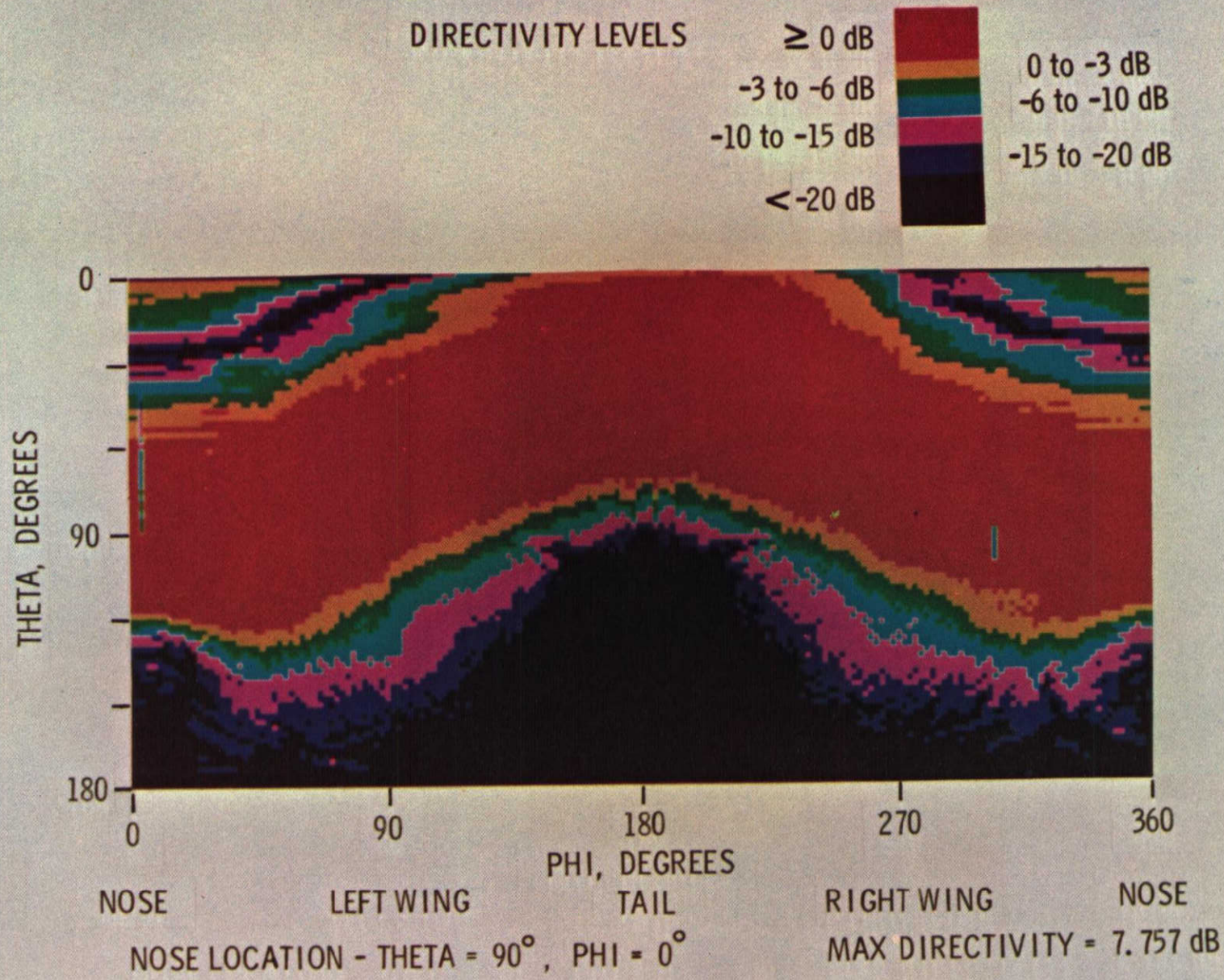

REPRODUCIBILITY OF THE  
 ORIGINAL PAGE IS POOR

(b) Monopole at station 220 on top fuselage with landing gear.



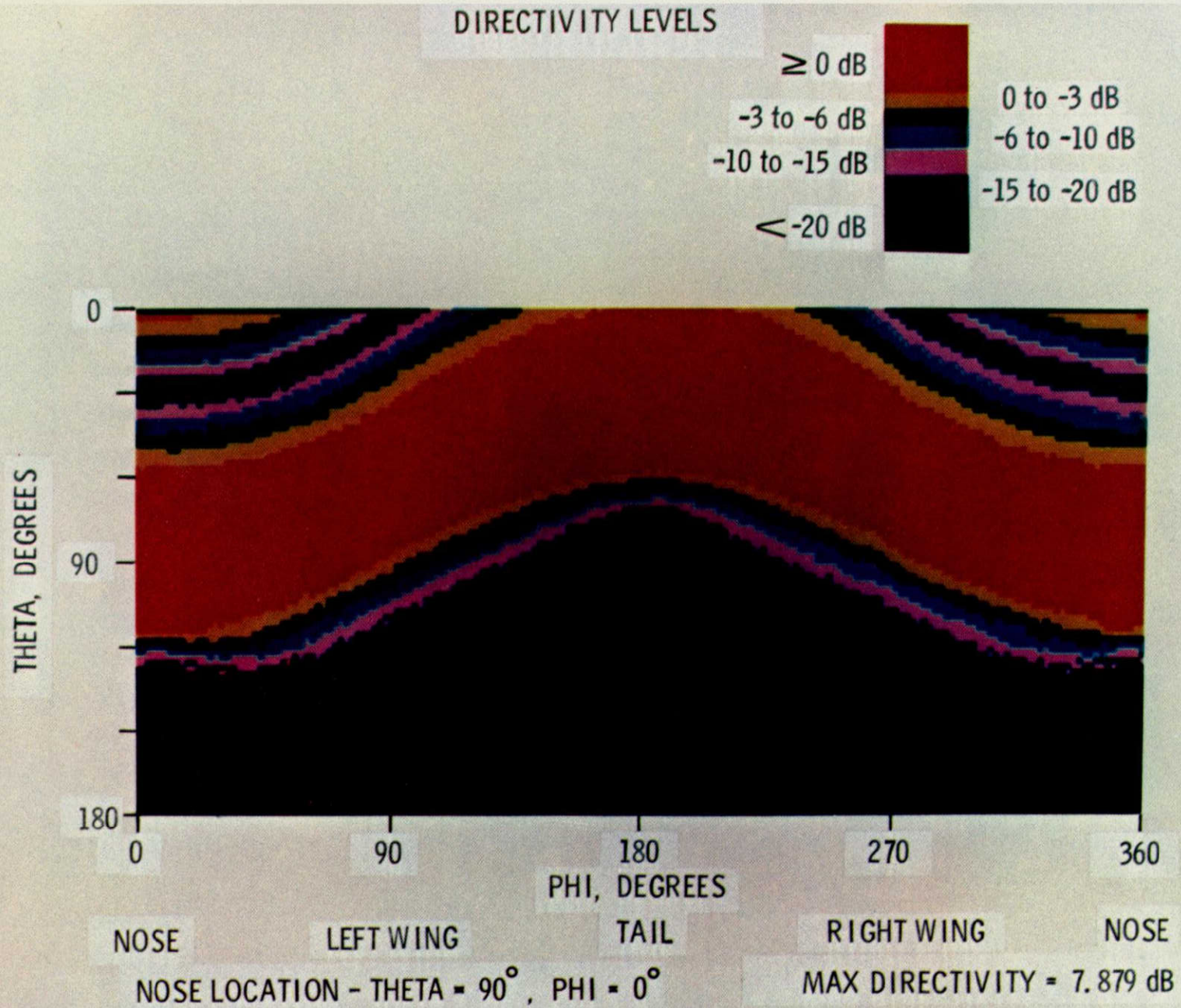

(c) Horizontally polarized coaxial fed slot antenna at station 220.



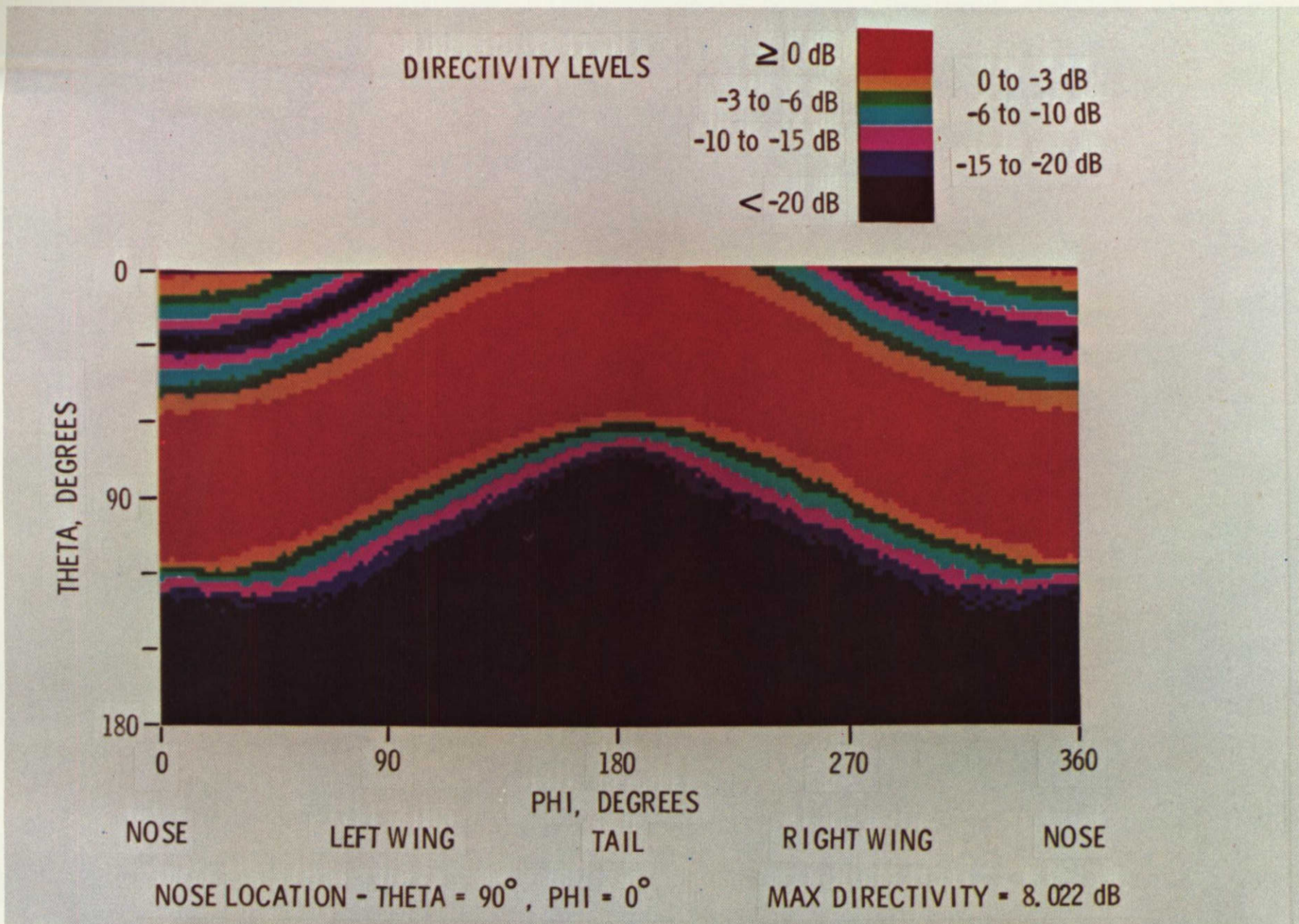

(d) Horizontally polarized coaxial fed slot antenna at station 220 with landing gear.



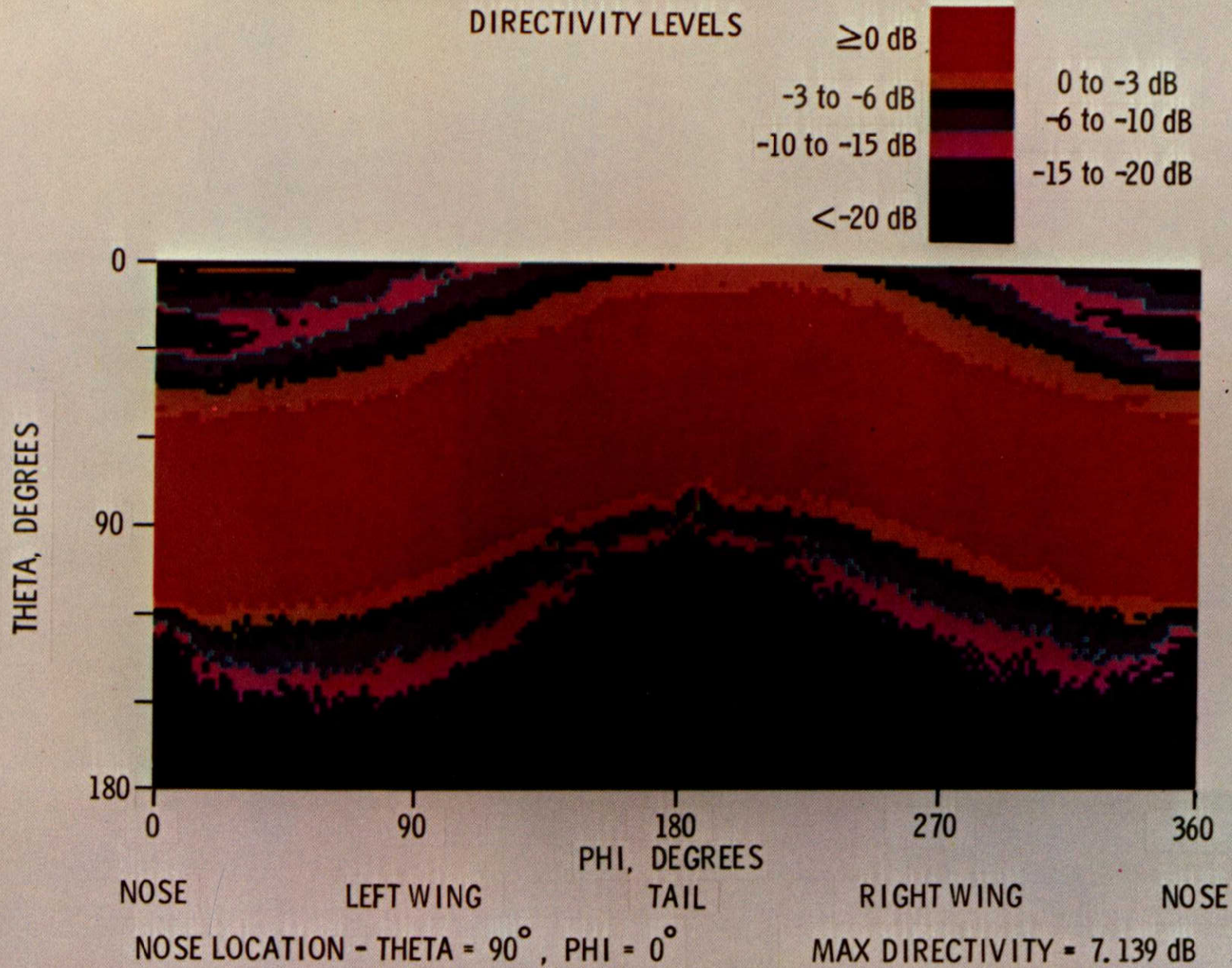

(e) Monopole at station 250 on top fuselage (off centerline).



REPRODUCIBILITY OF THE ORIGINAL PAGE IS POOR

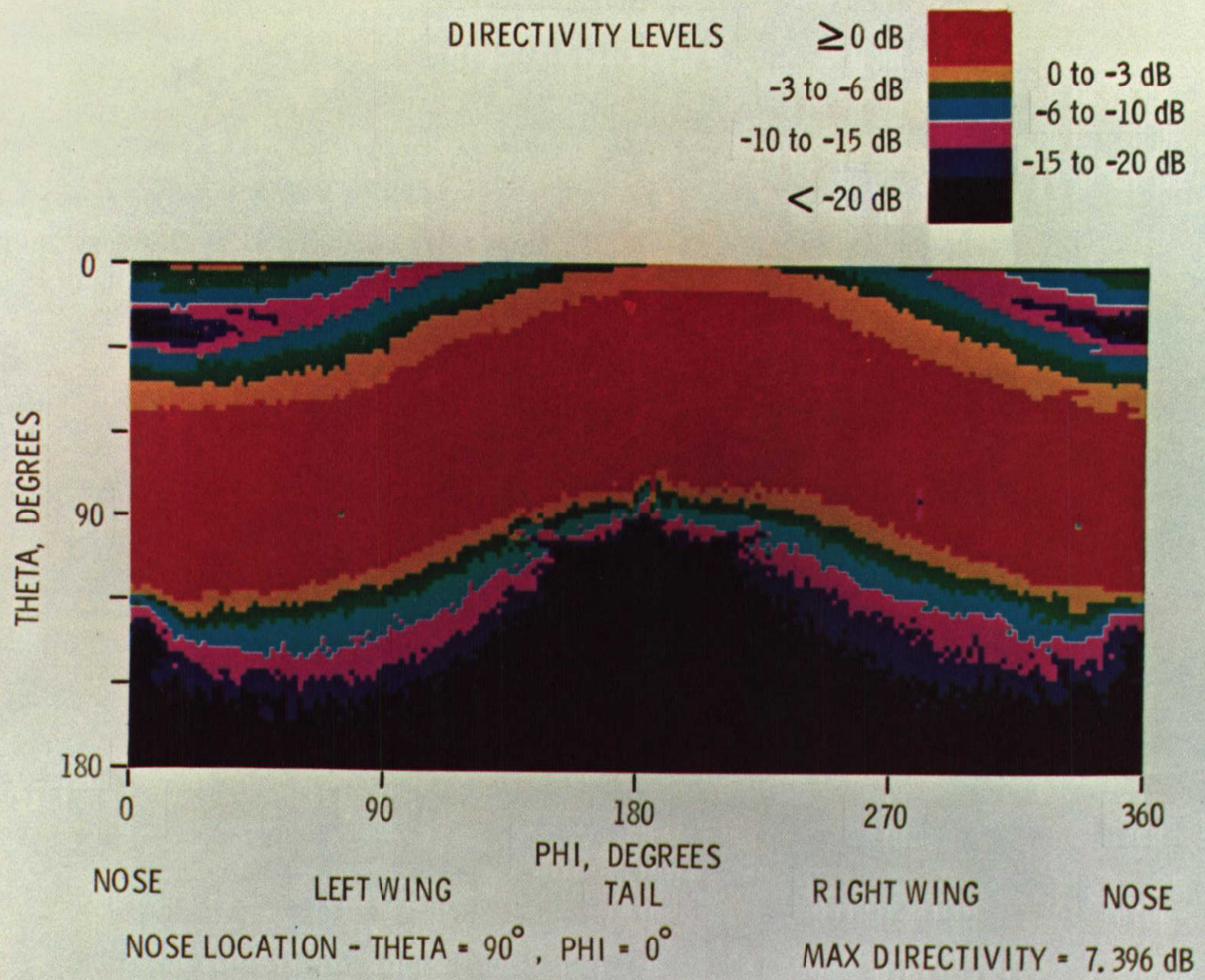

(f) Monopole at station 250 on top fuselage (off centerline) with landing gear.



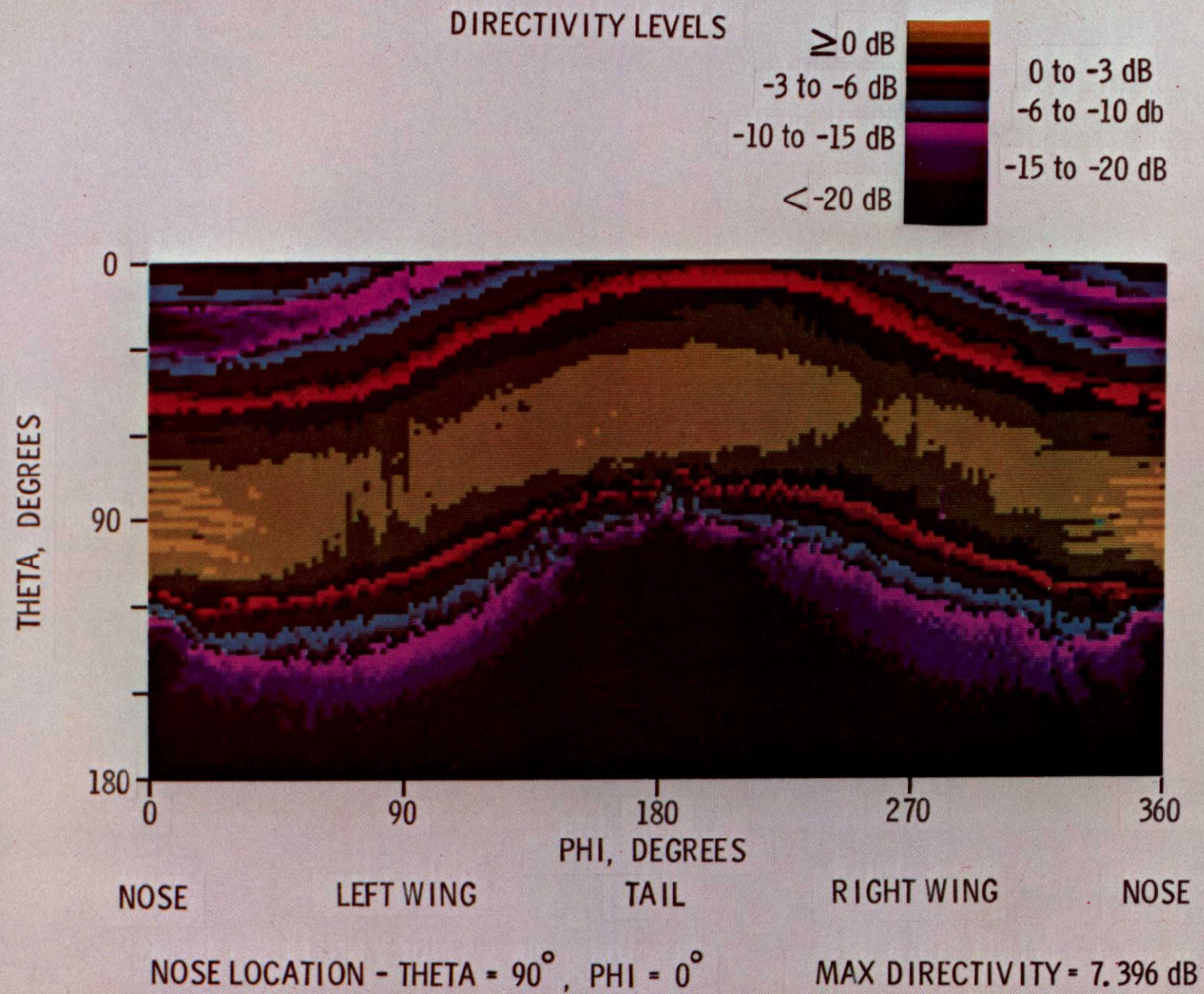

(g) Monopole at station 250 on top fuselage (off centerline) with landing gear.



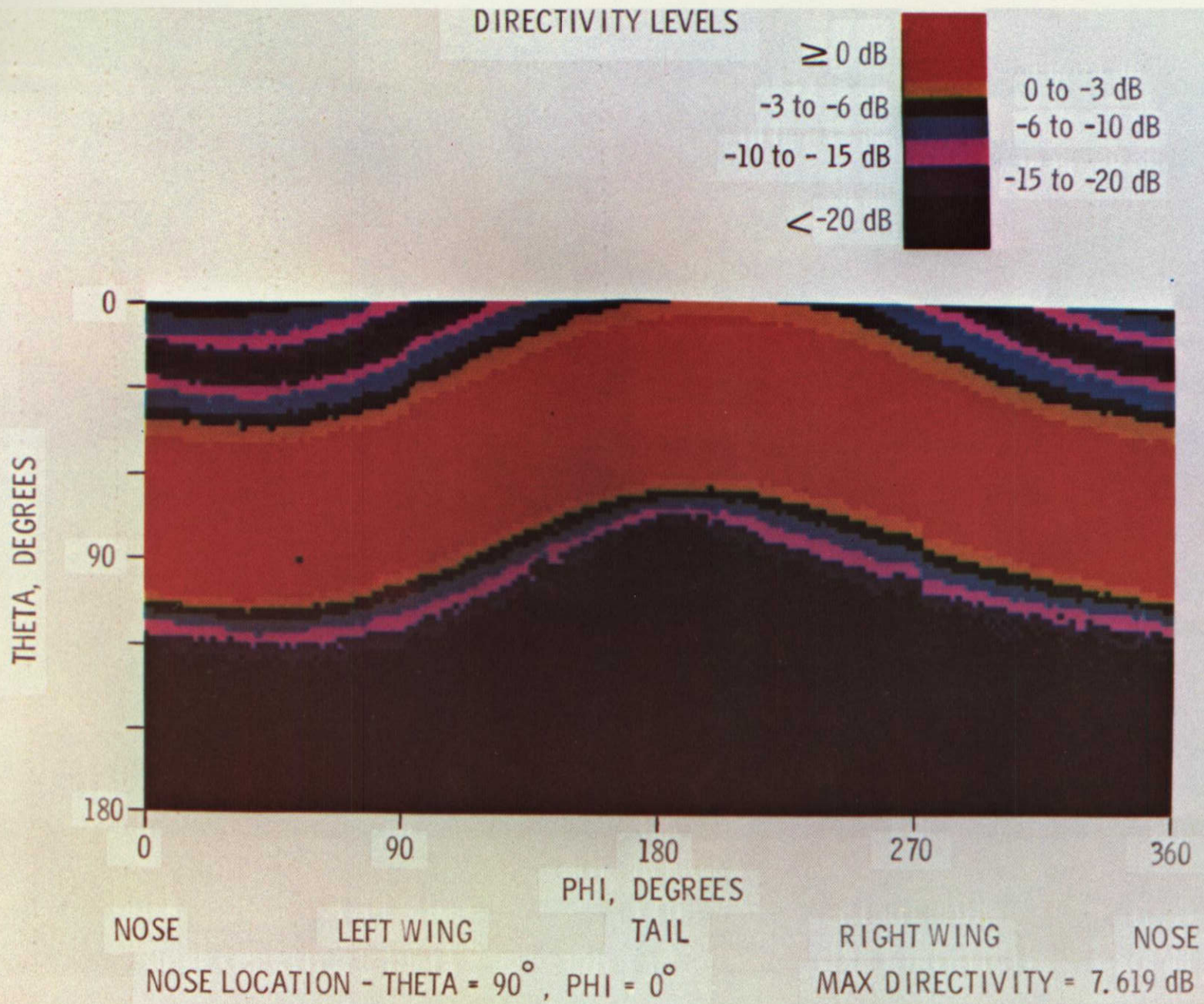

(h) Horizontally polarized coaxial fed slot antenna at station 250 on top fuselage (off centerline) with landing gear.

Figure 8.- Continued.

ORIGINAL PAGE IS POOR



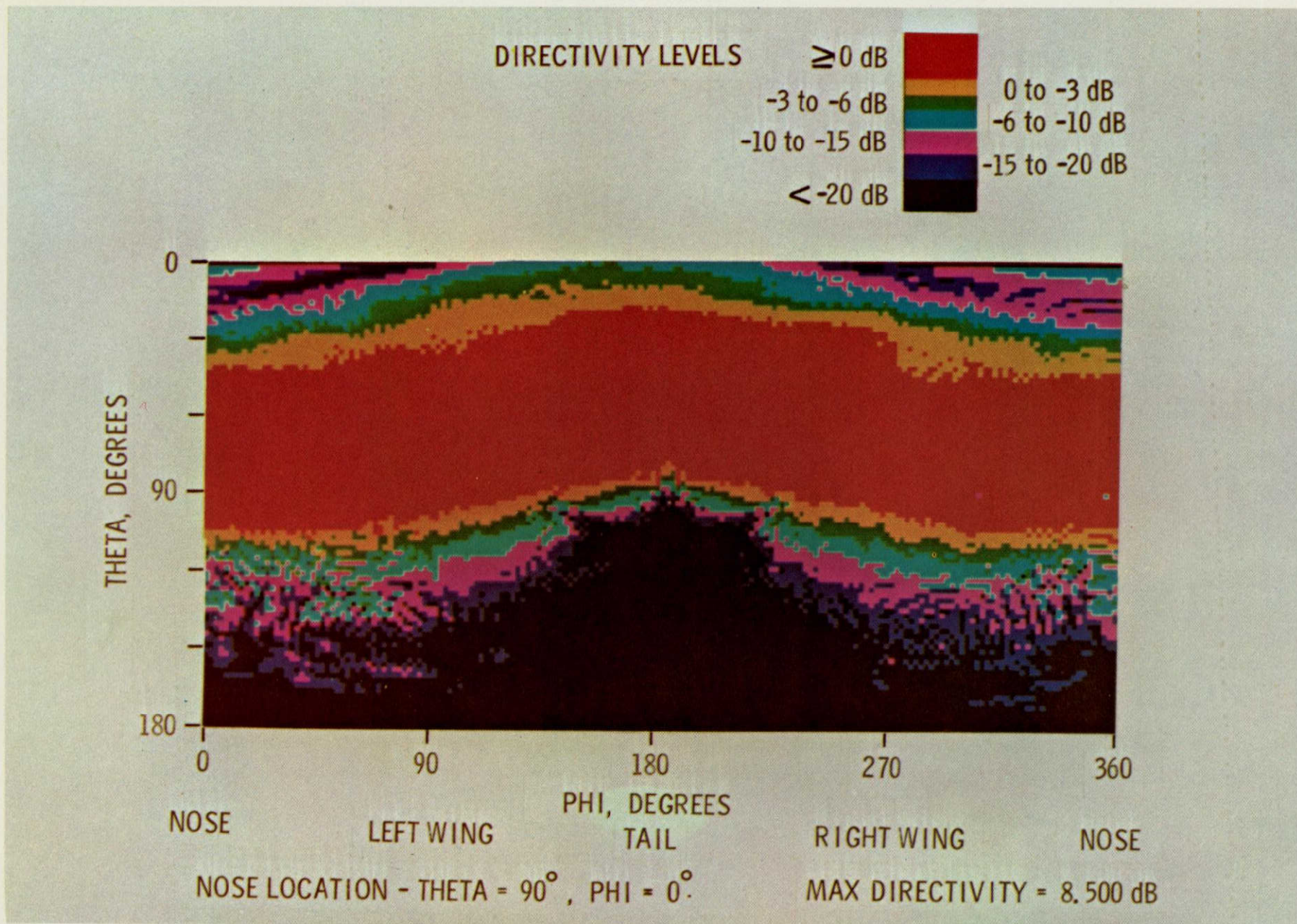

(i) Monopole at station 305 on top fuselage.

Figure 8.- Continued.



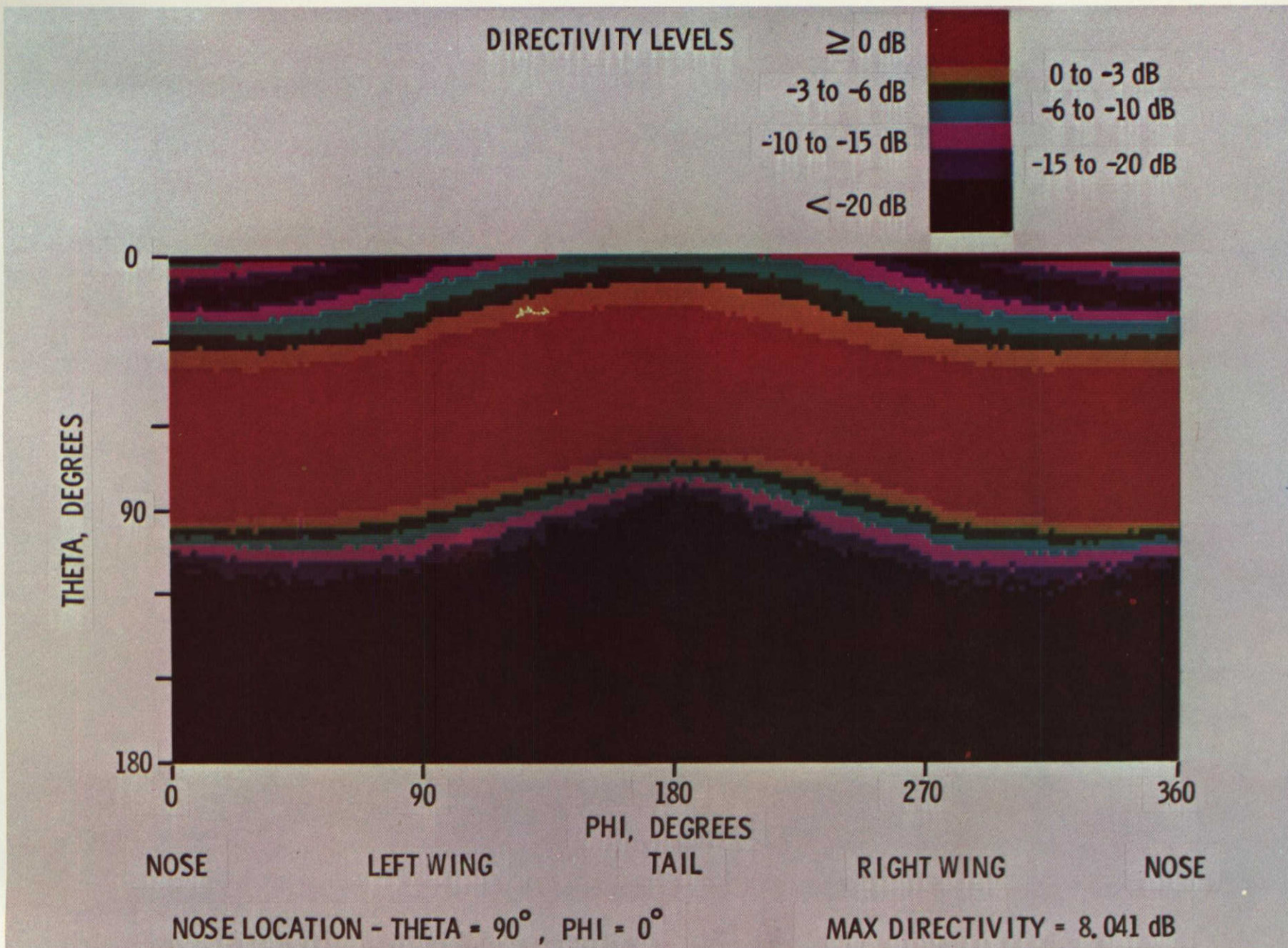

(j) Horizontally polarized coaxial fed slot antenna at station 305 on top fuselage with landing gear.



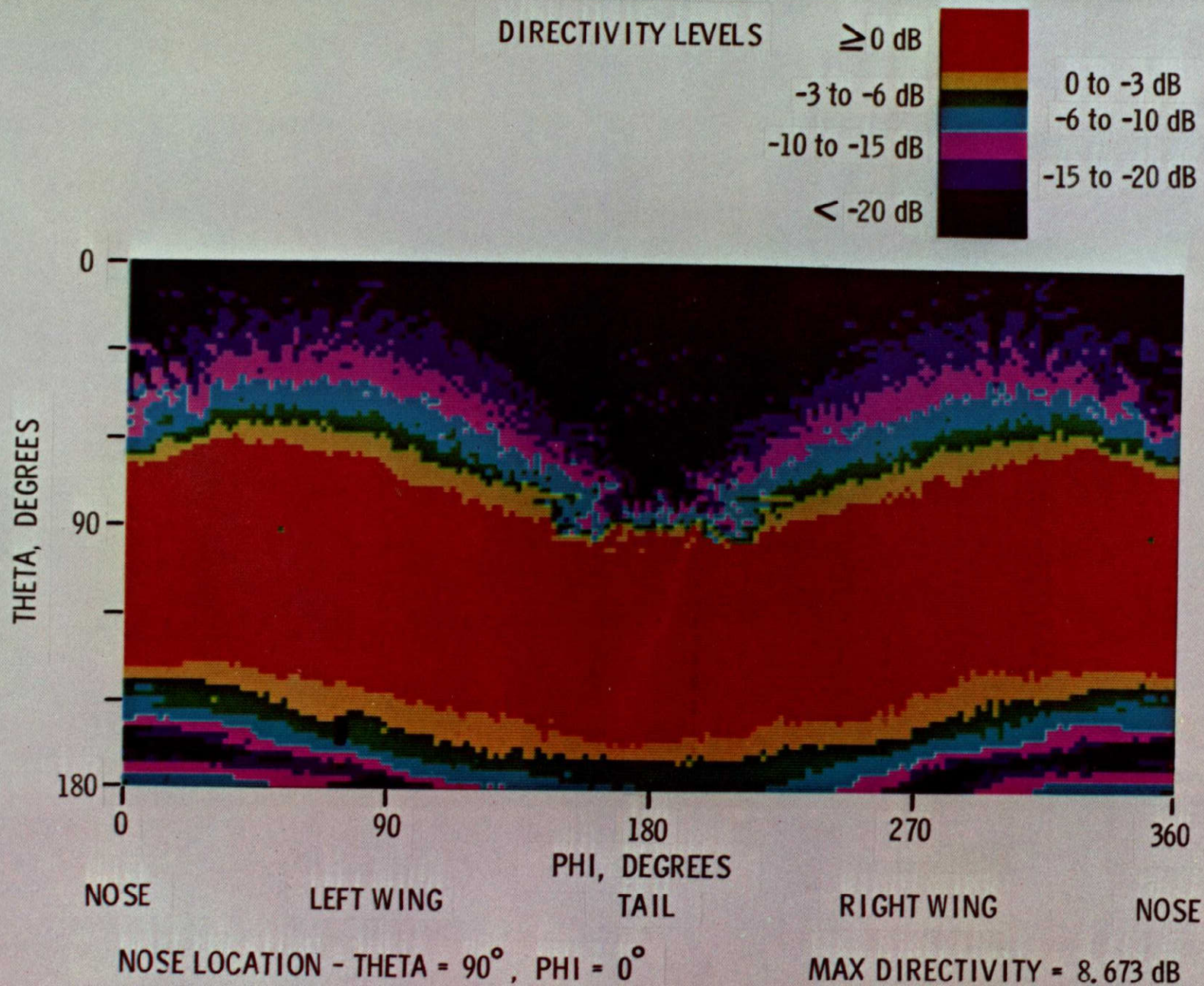

(k) Monopole at station 222 on bottom fuselage.



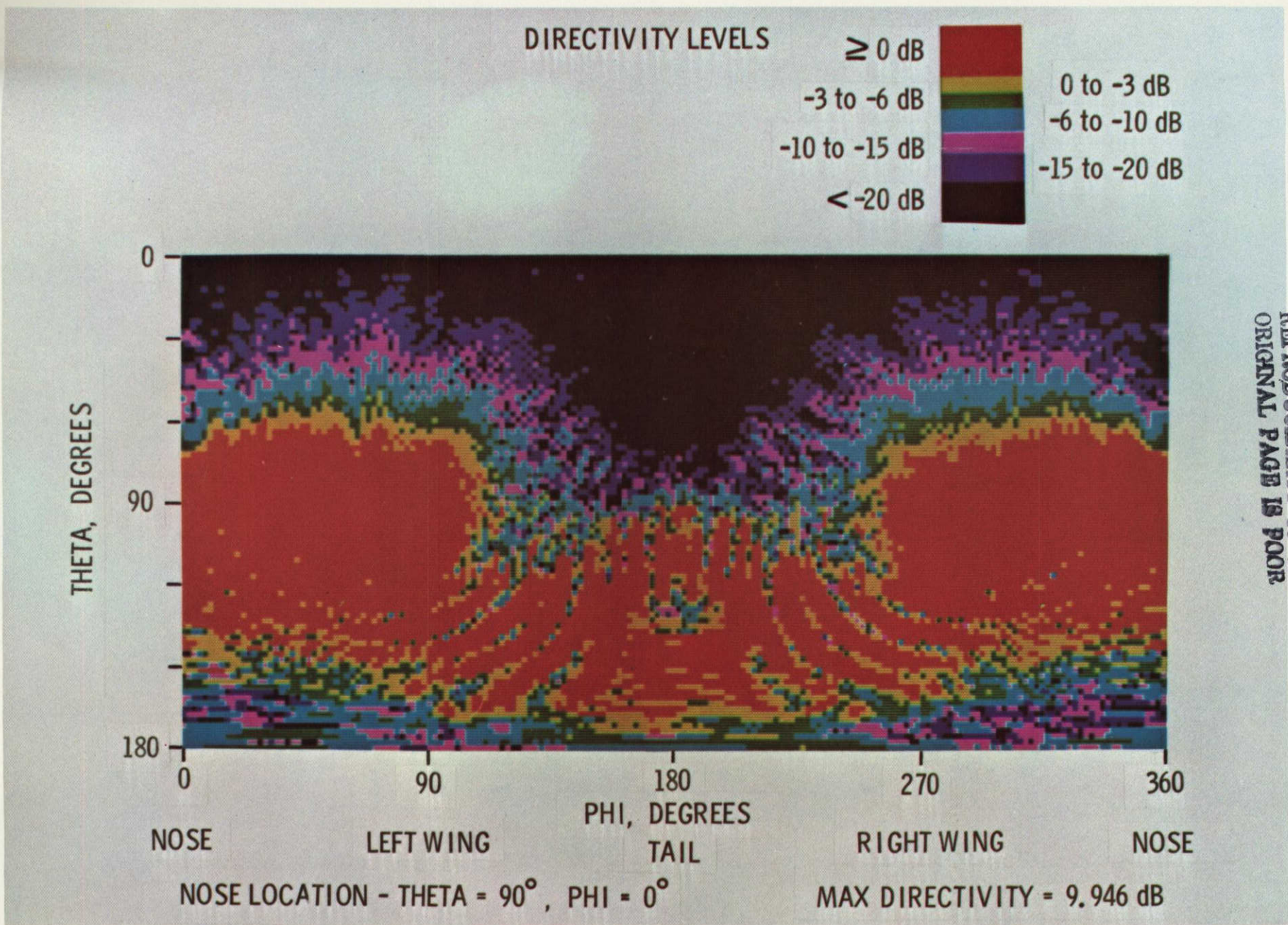

REPRODUCIBILITY OF THE ORIGINAL PAGE IS POOR

(1) Monopole at station 222 on bottom fuselage with landing gear.

Figure 8.- Continued.



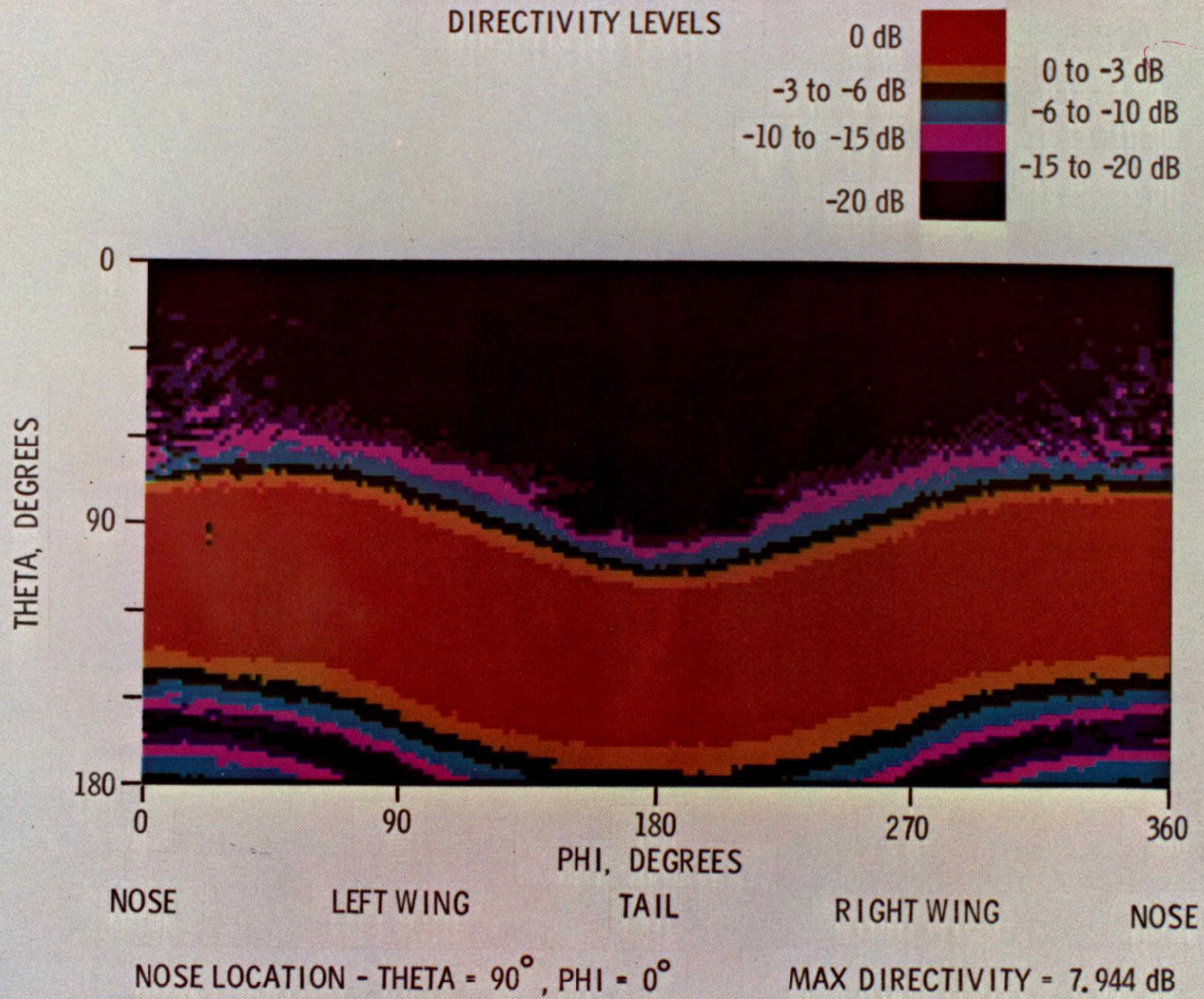

(m) Horizontally polarized coaxial fed slot antenna at station 222 on bottom fuselage.



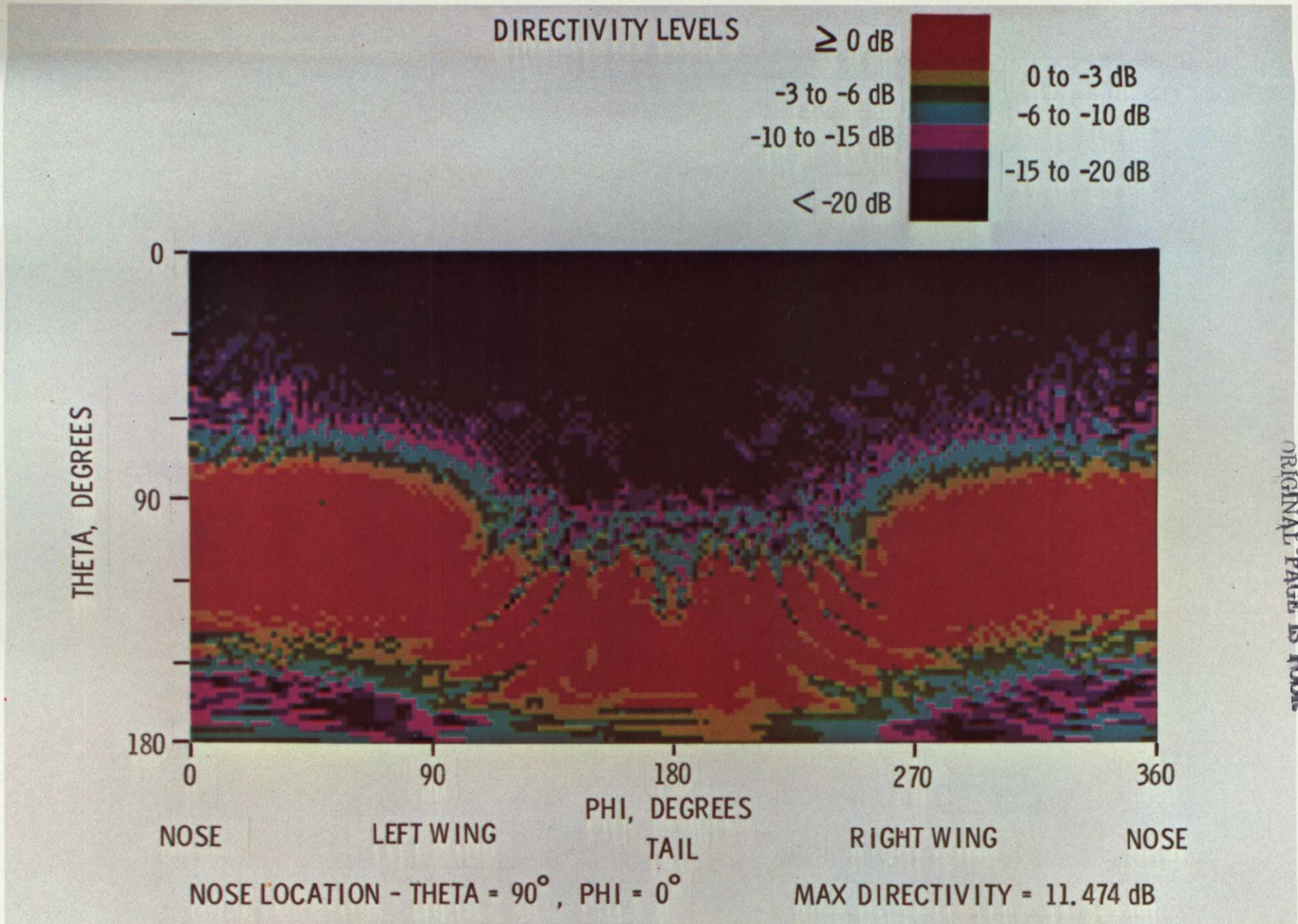

REPRODUCIBILITY OF THE ORIGINAL PAGE IS POOR

(n) Horizontally polarized coaxial fed slot antenna at station 222 on bottom fuselage with landing gear.



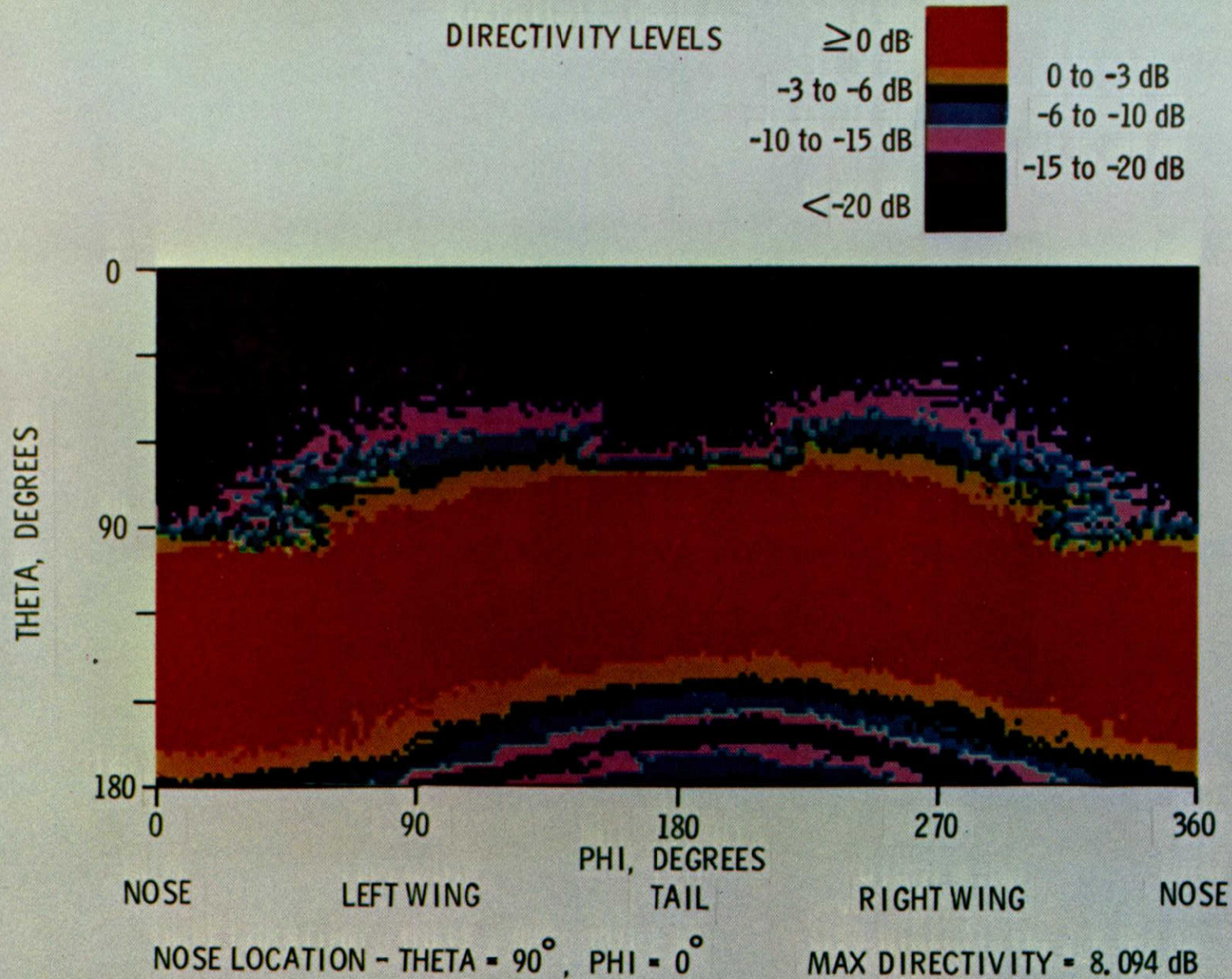

(o) Monopole at station 950 on bottom fuselage.



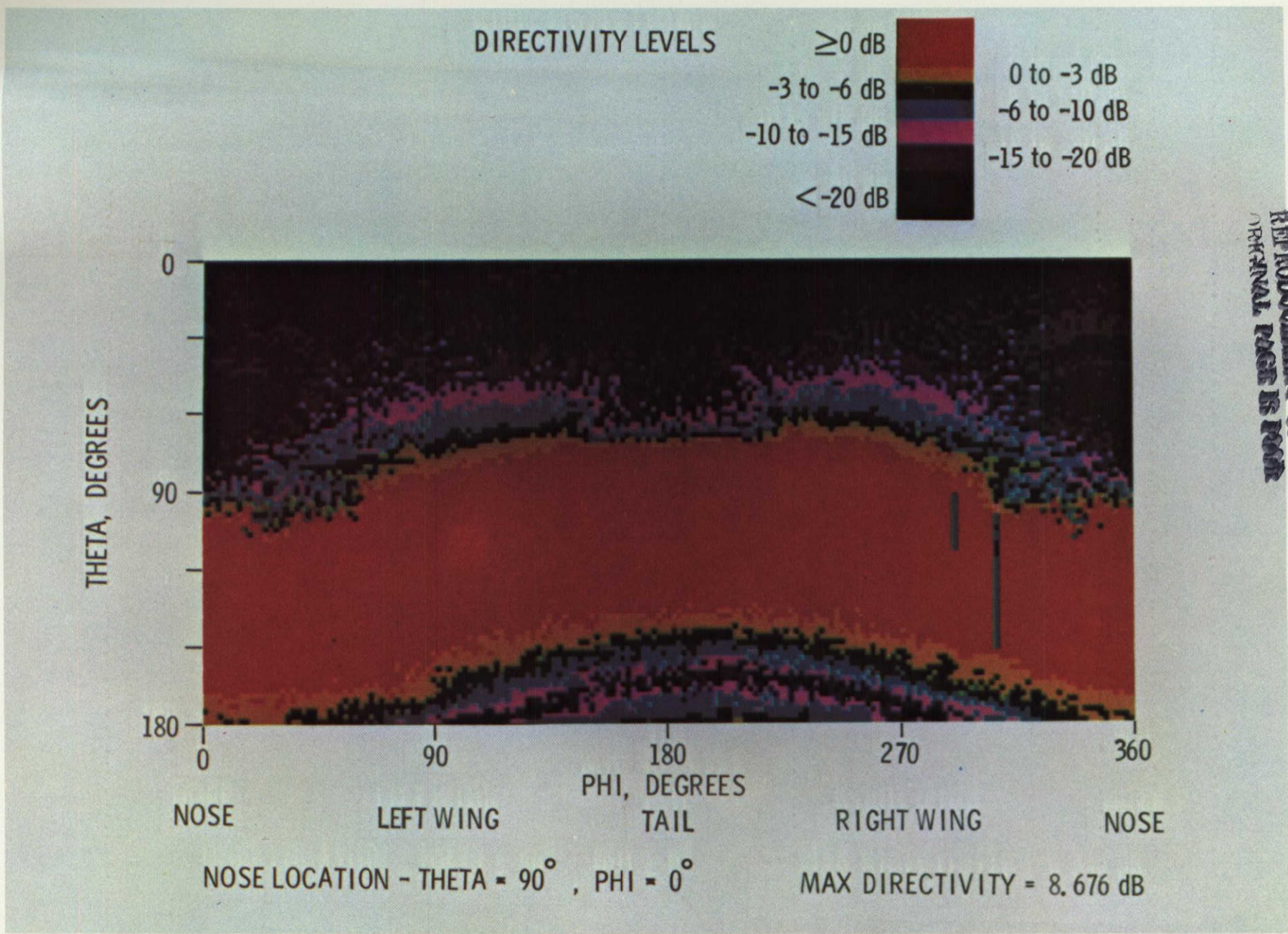

REPRODUCTION OF THIS ORIGINAL PAGE IS FORN

(p) Monopole at station 950 on bottom fuselage with landing gear.



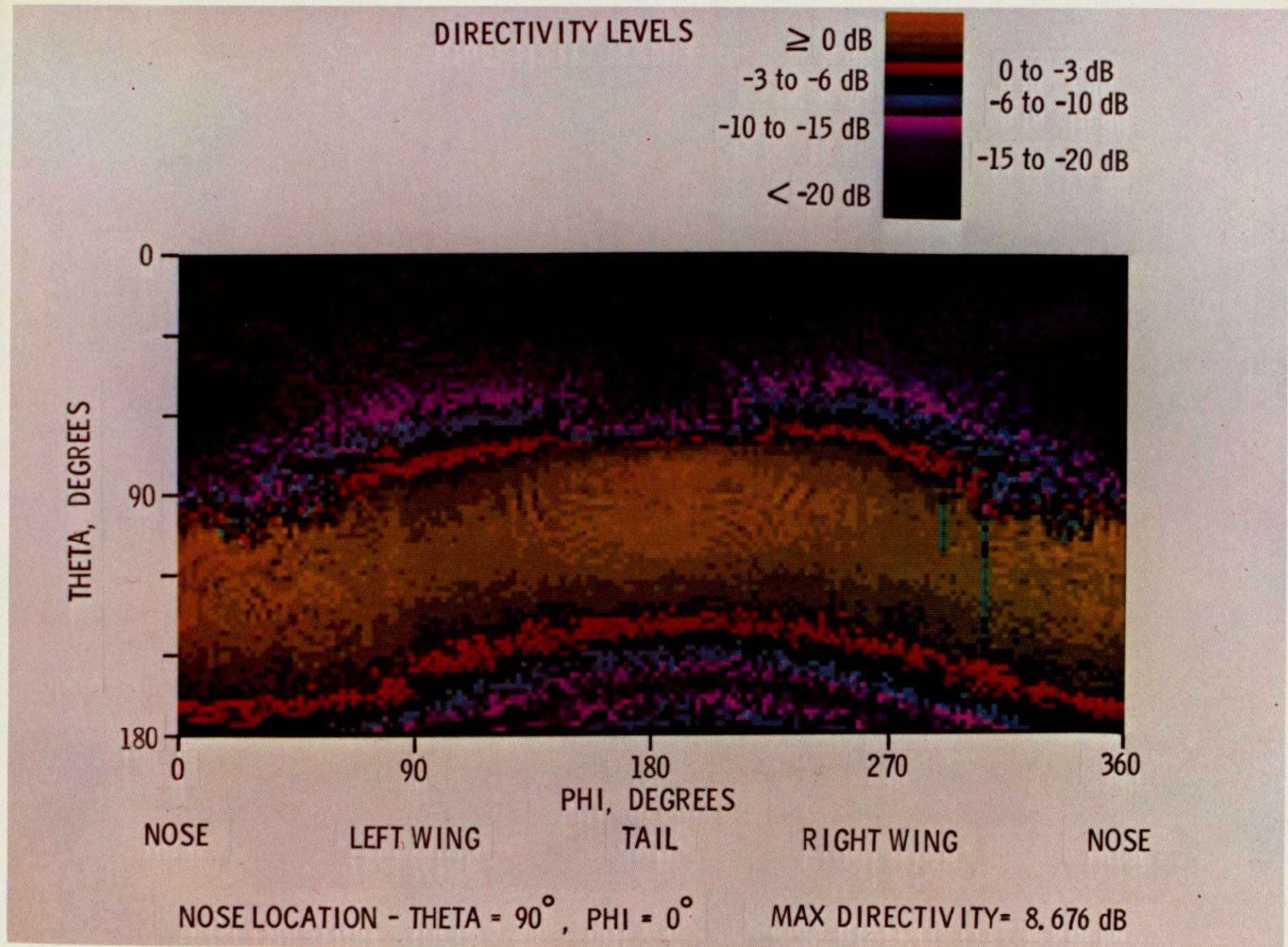

(q) Monopole at station 950 on bottom fuselage with landing gear.

Figure 8.- Continued.



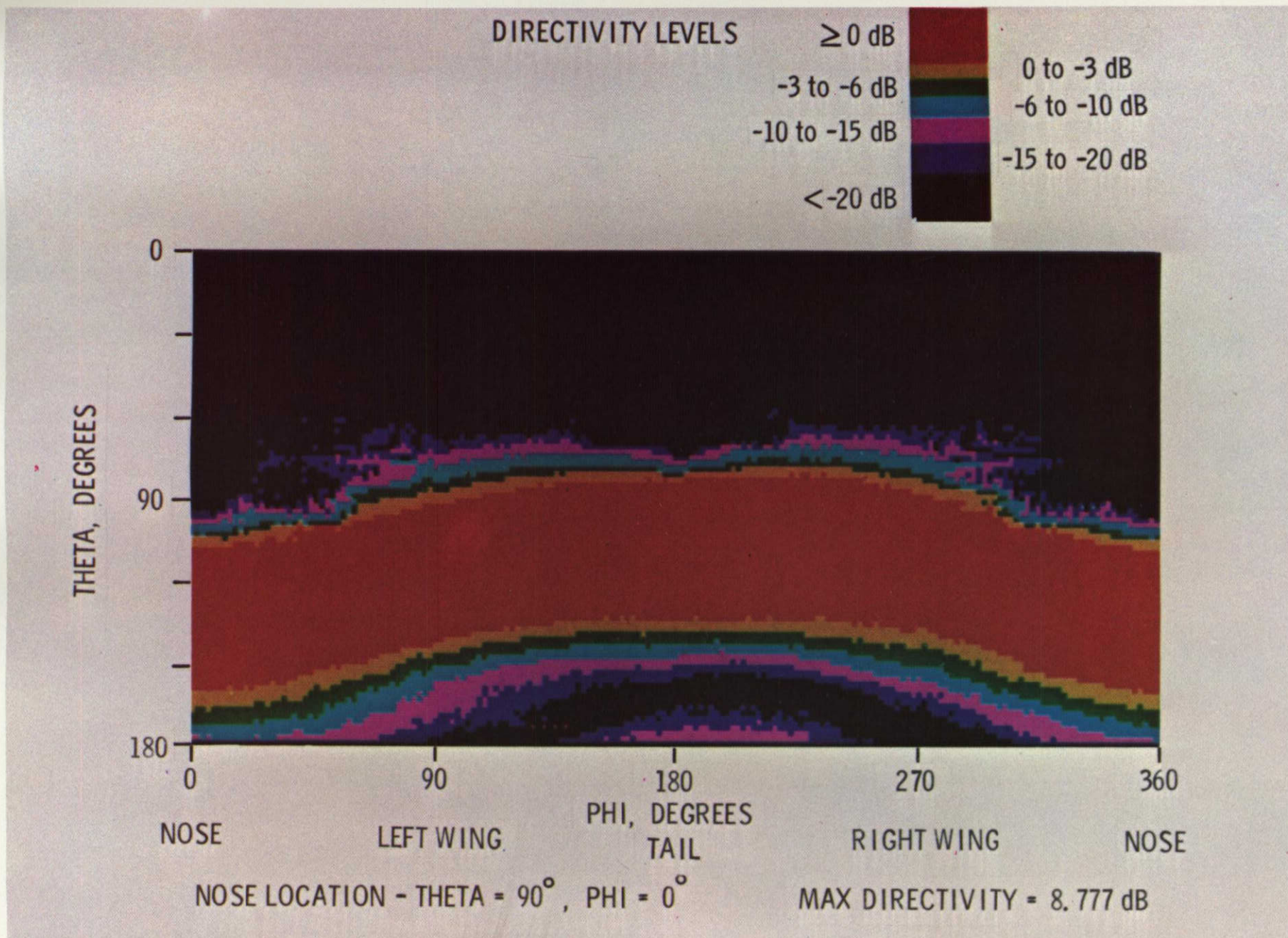

(r) Horizontally polarized coaxial fed slot antenna at station 950 on bottom fuselage.



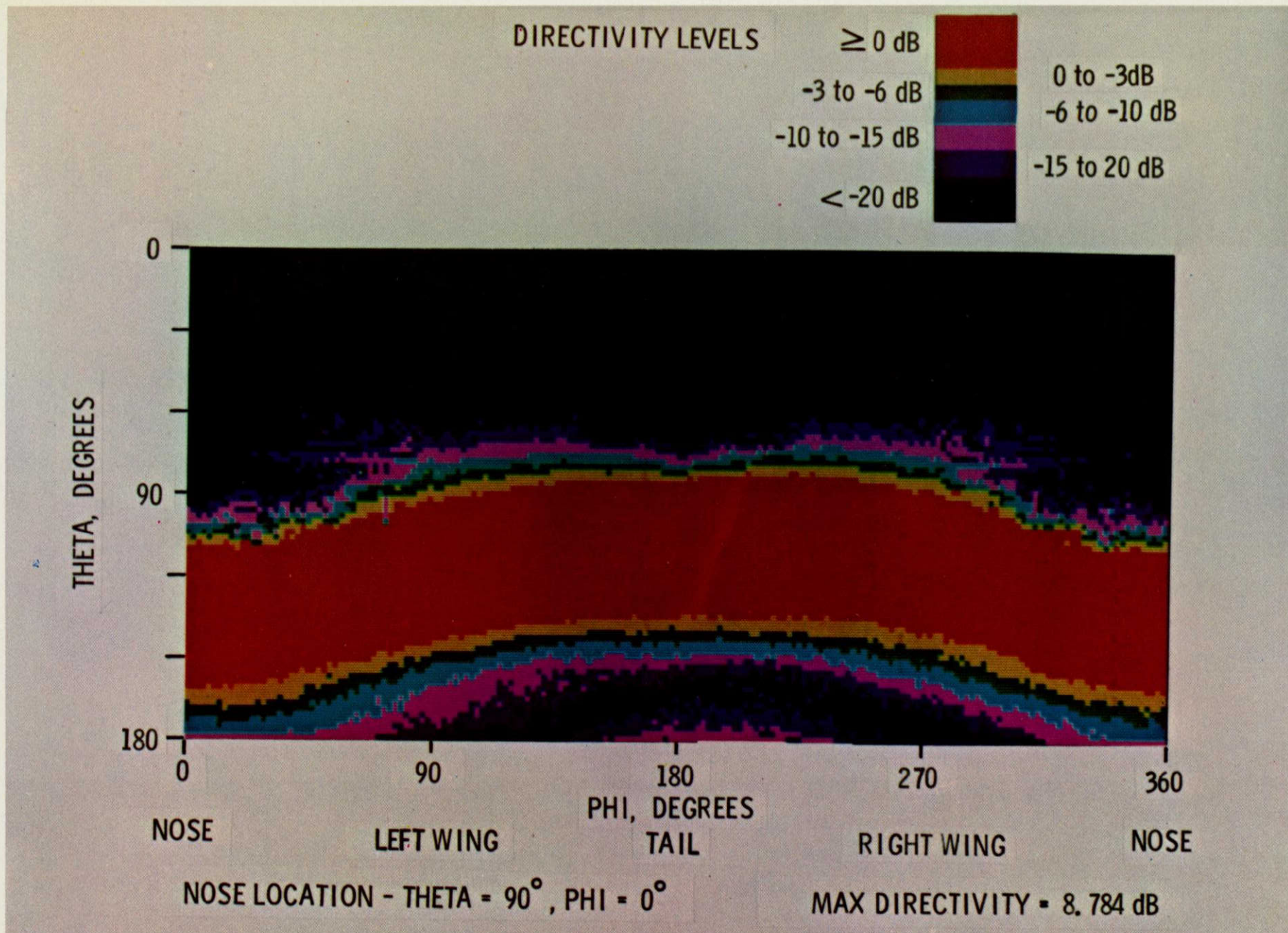

(s) Horizontally polarized coaxial fed slot antenna at station 950 on bottom fuselage with landing gear.



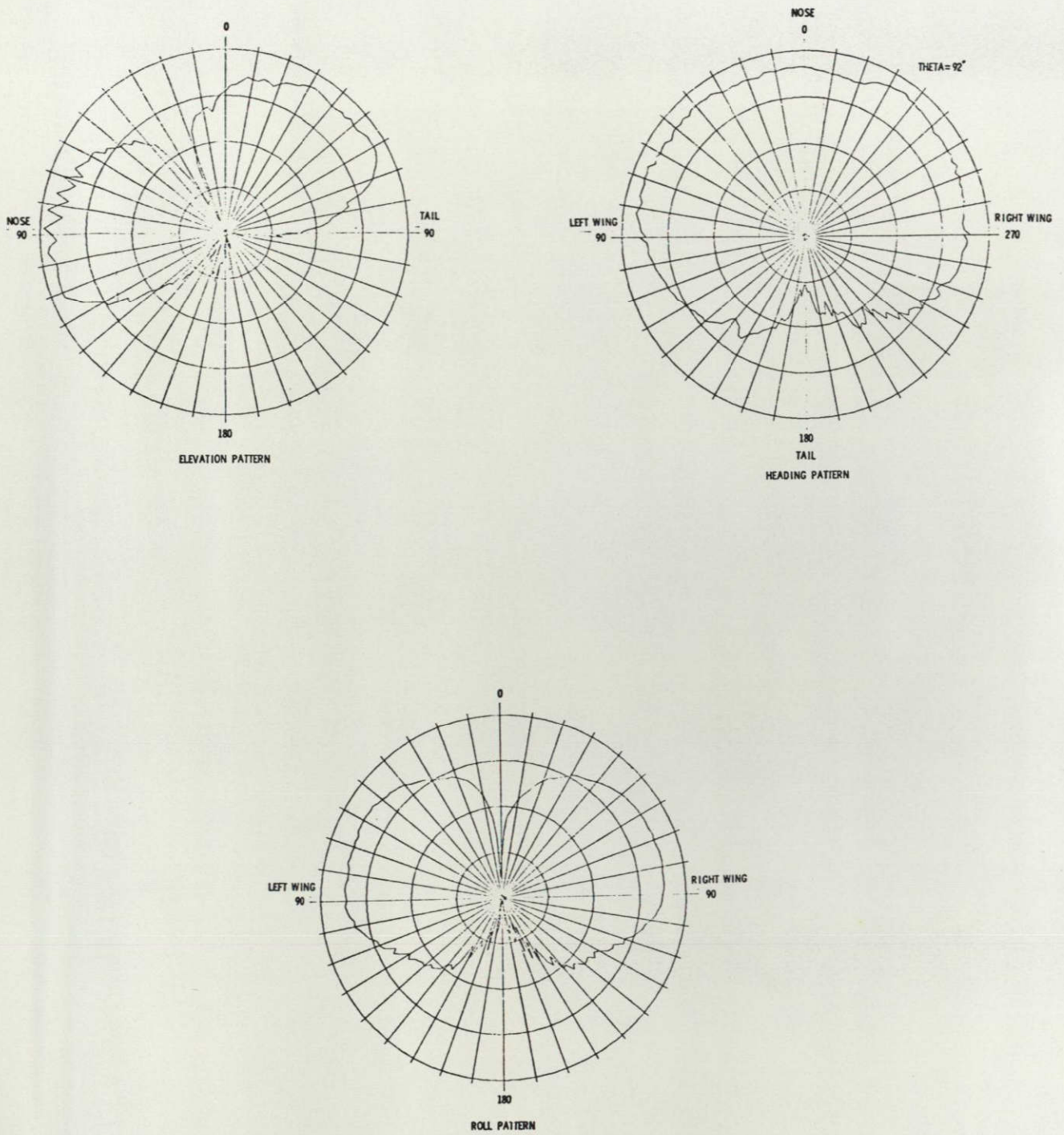

(a) Monopole at station 220 on top fuselage.

Figure 9.- Principal plane patterns of omnidirectional antennas on one-eleventh scale model of Boeing 737.

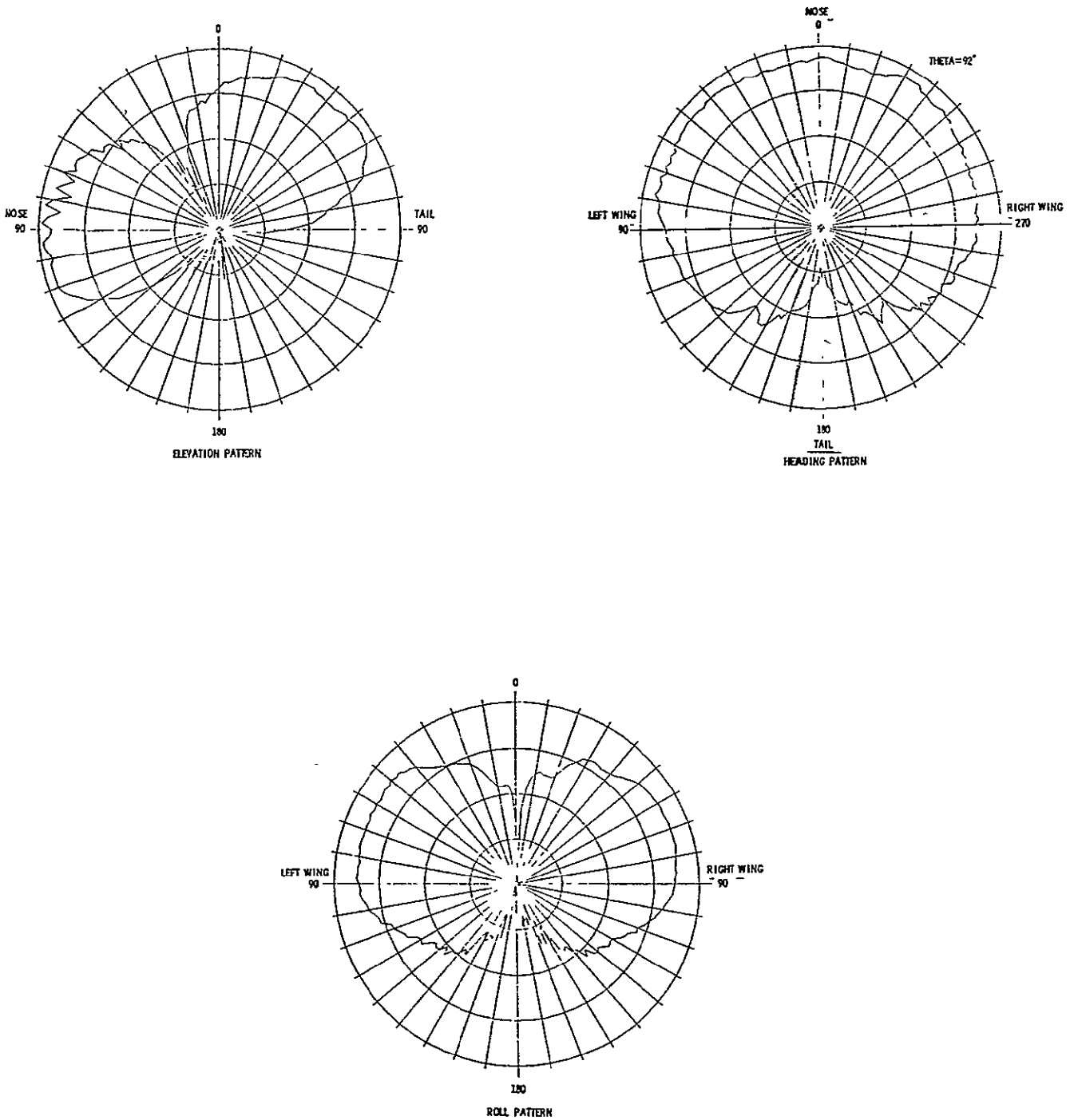

(b) Monopole at station 220 on top fuselage with landing gear.

Figure 9.- Continued.

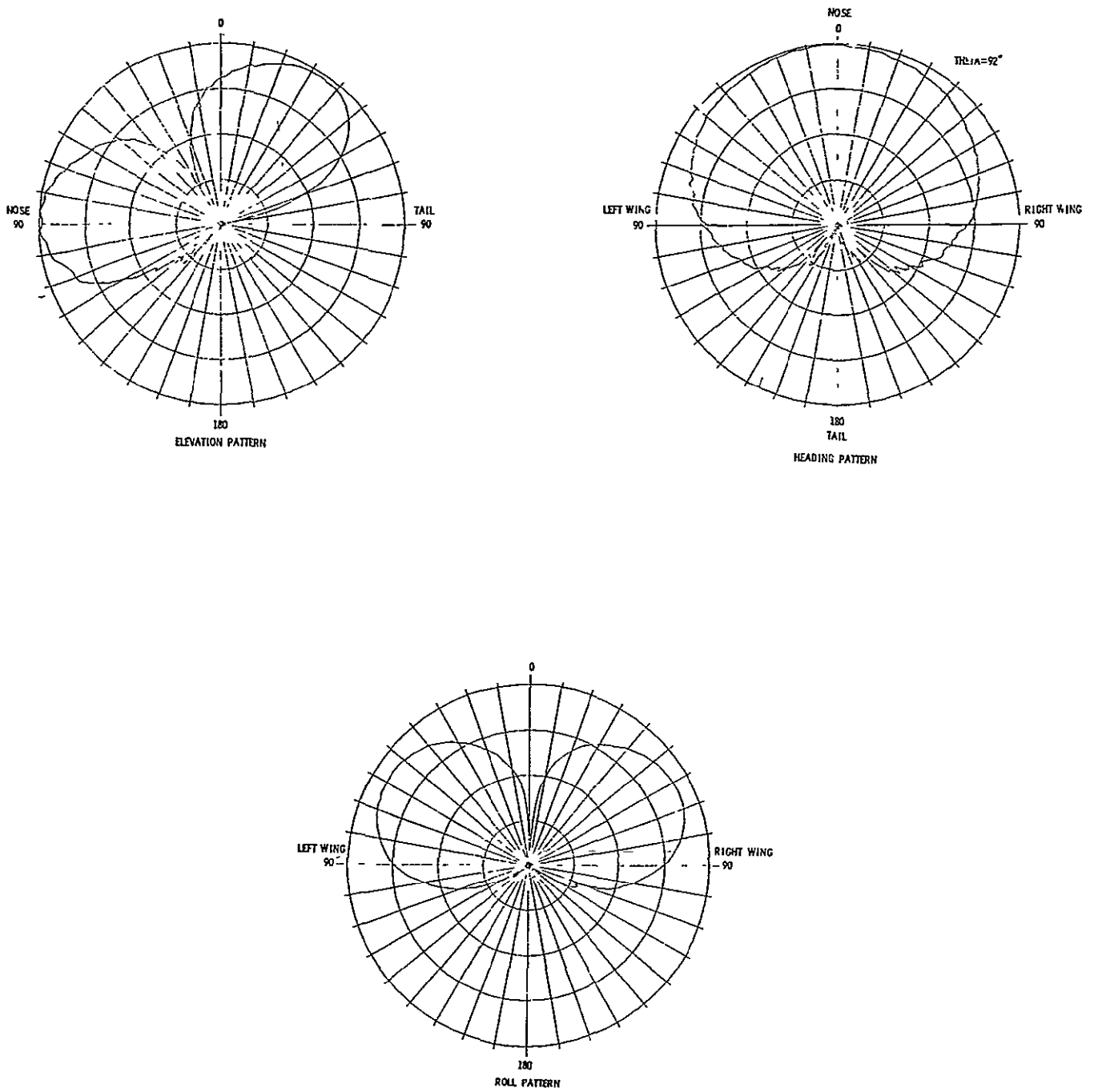

(c) Horizontally polarized coaxial fed slot antenna  
at station 220.



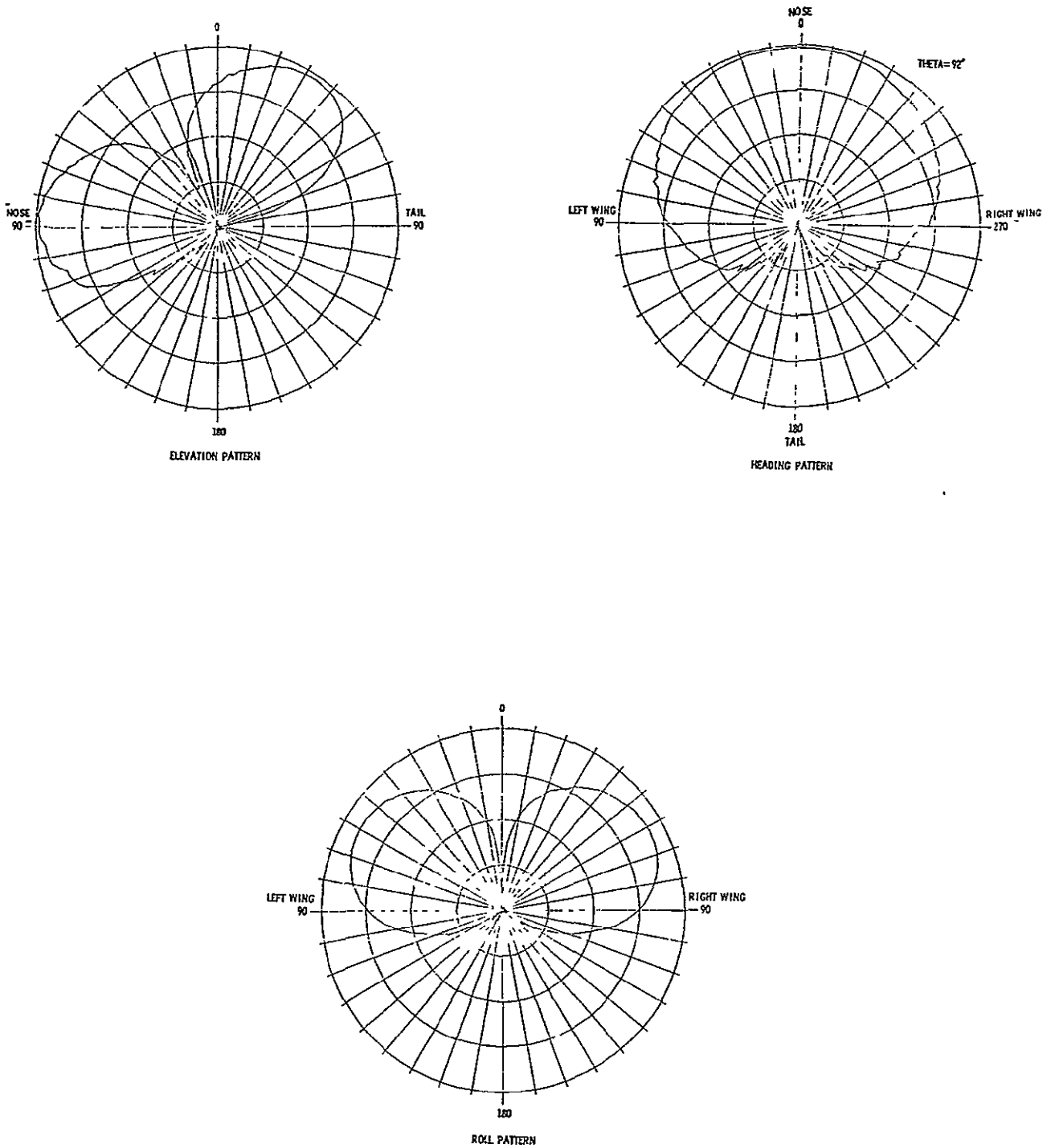

(d) Horizontally polarized coaxial fed slot antenna at station 220 with landing gear.

Figure 9.- Continued.

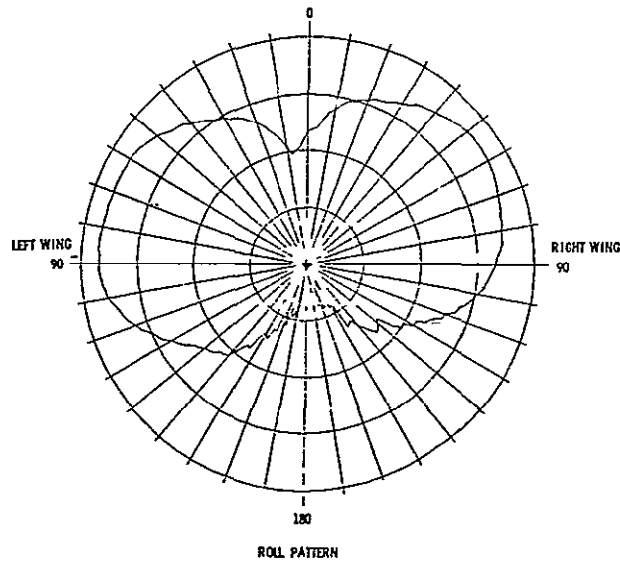
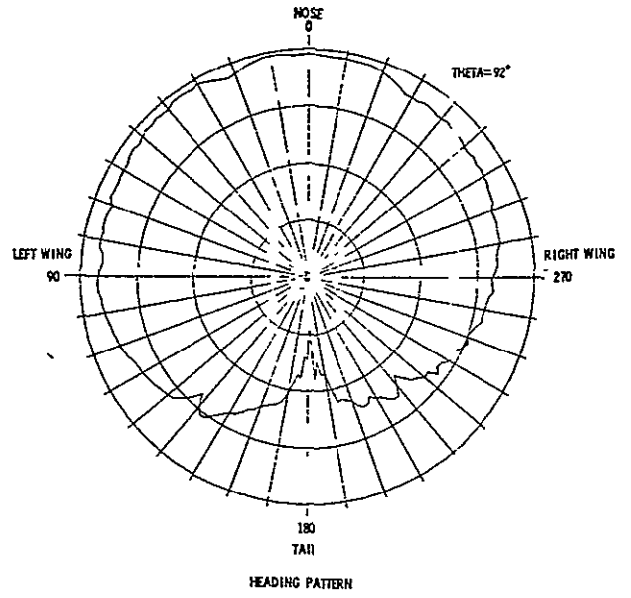
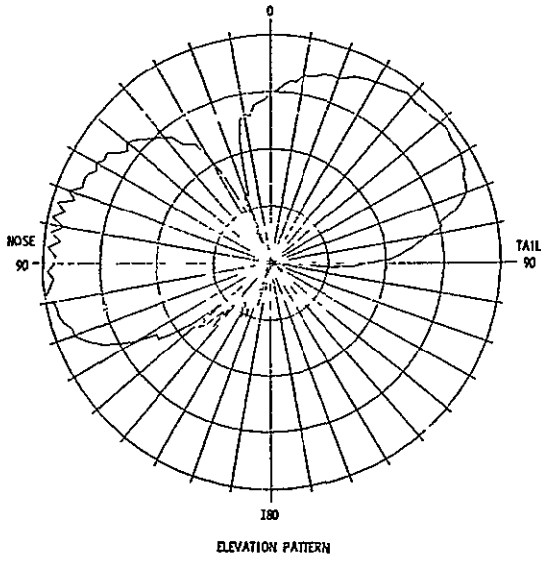

(e) Monopole at station 250 on top fuselage (off centerline).

Figure 9.- Continued.

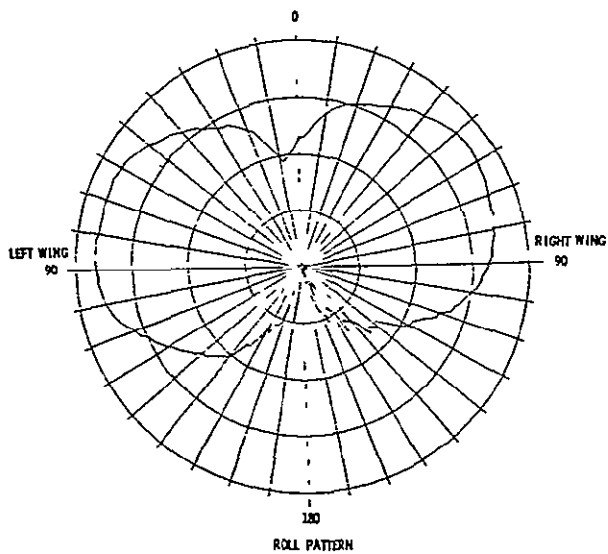
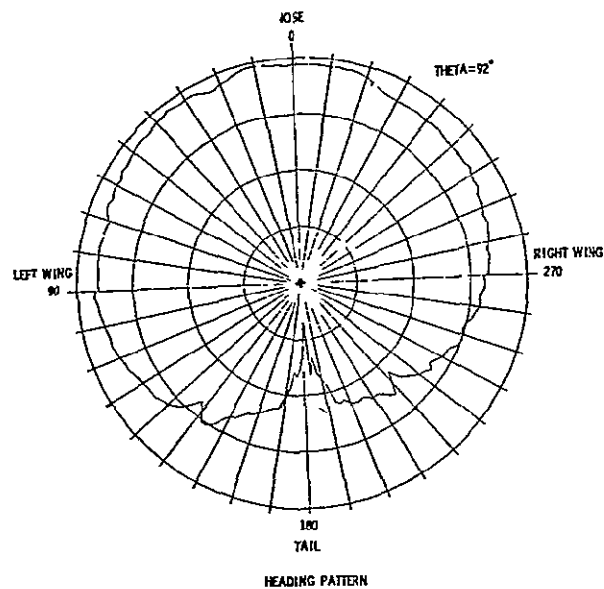
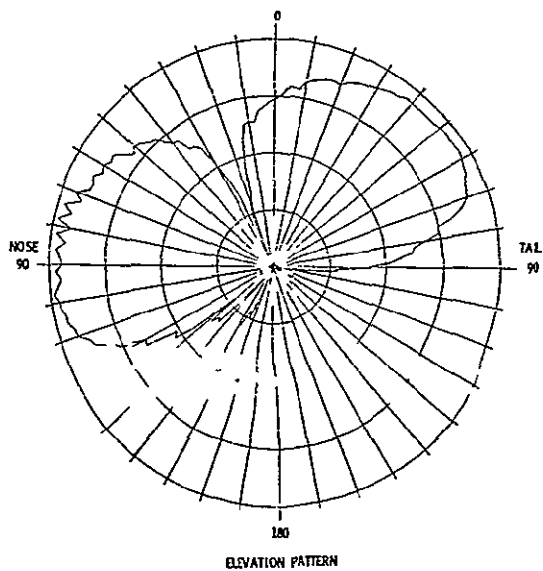

(f) Monopole at station 250 on top fuselage (off centerline with landing gear).

Figure 9.- Continued.



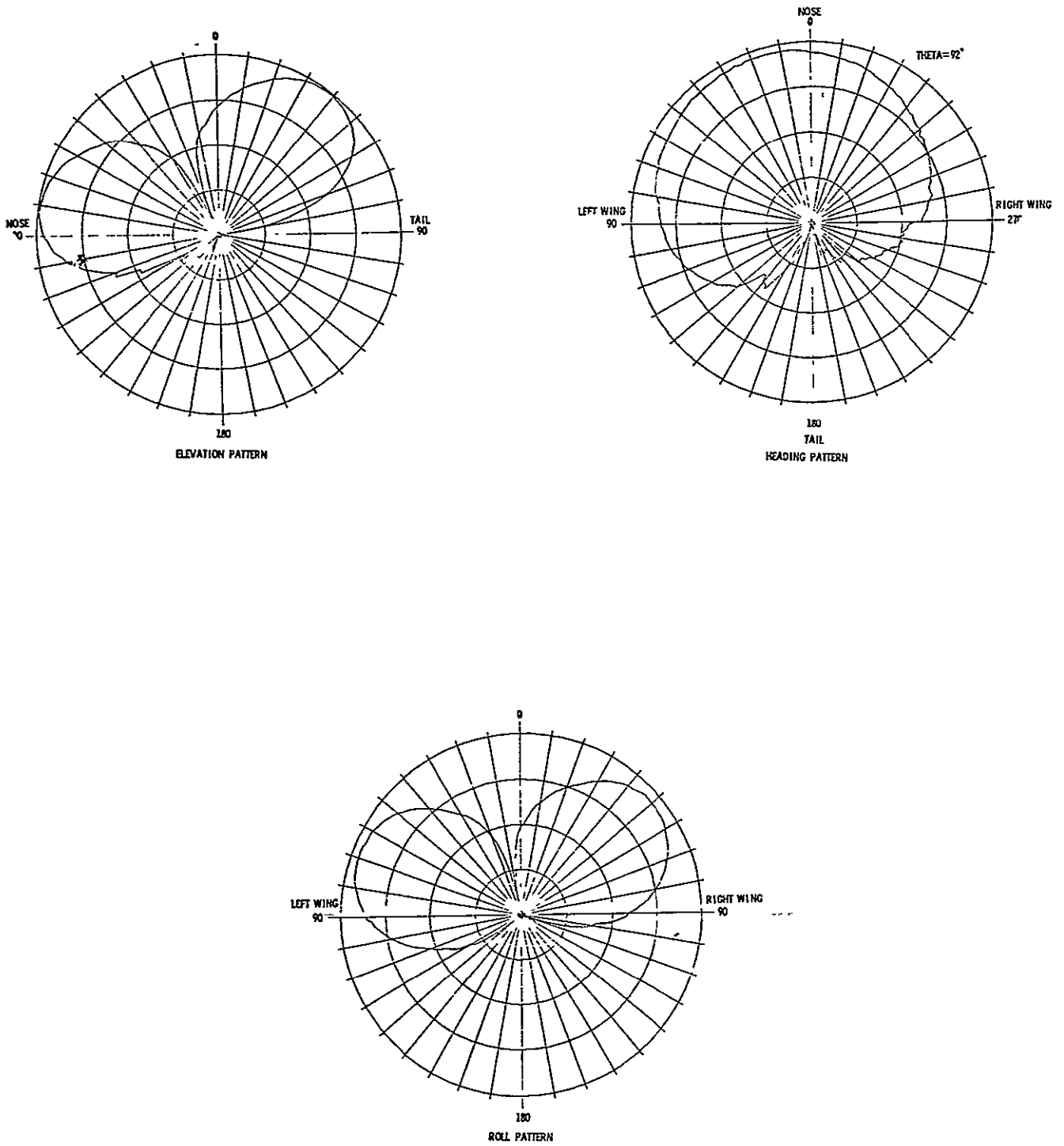

(g) Horizontally polarized coaxial fed slot antenna at station 250 on top fuselage (off centerline) with landing gear.

Figure 9.- Continued.

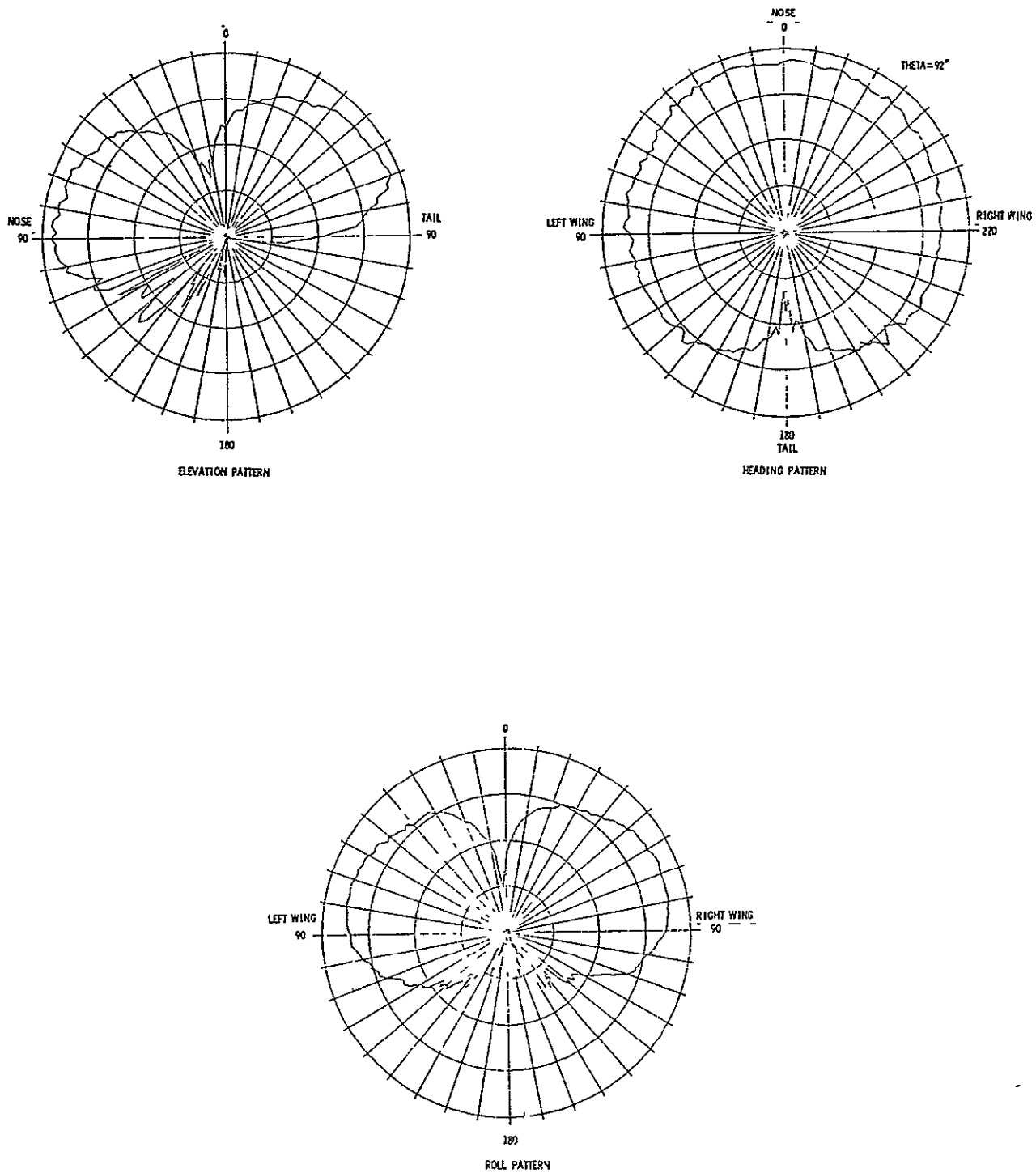

(h) Monopole at station 305 on top fuselage.

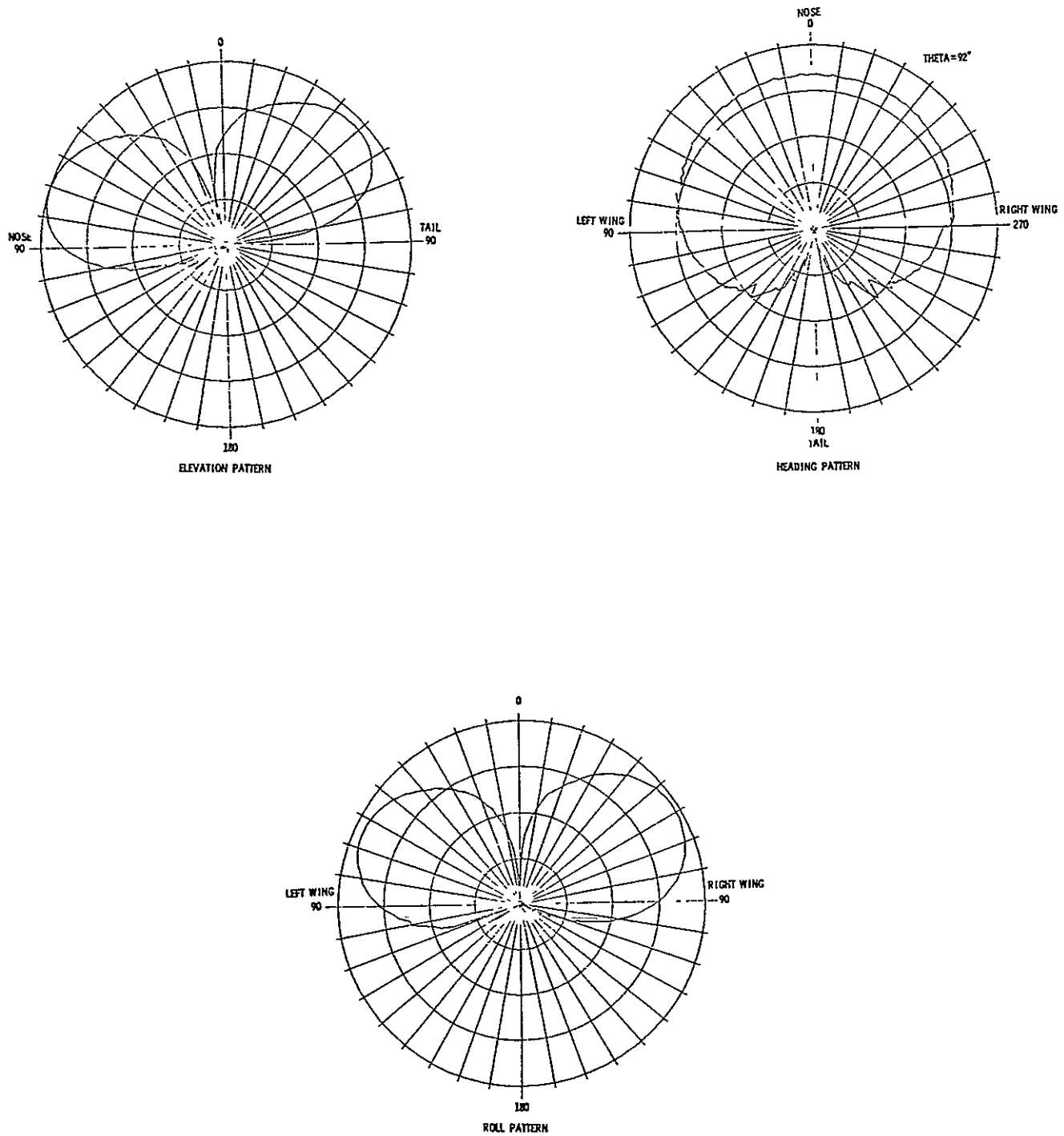

- (1) Horizontally polarized coaxial fed slot antenna at station 305 on top fuselage with landing gear.

Figure 9.- Continued.



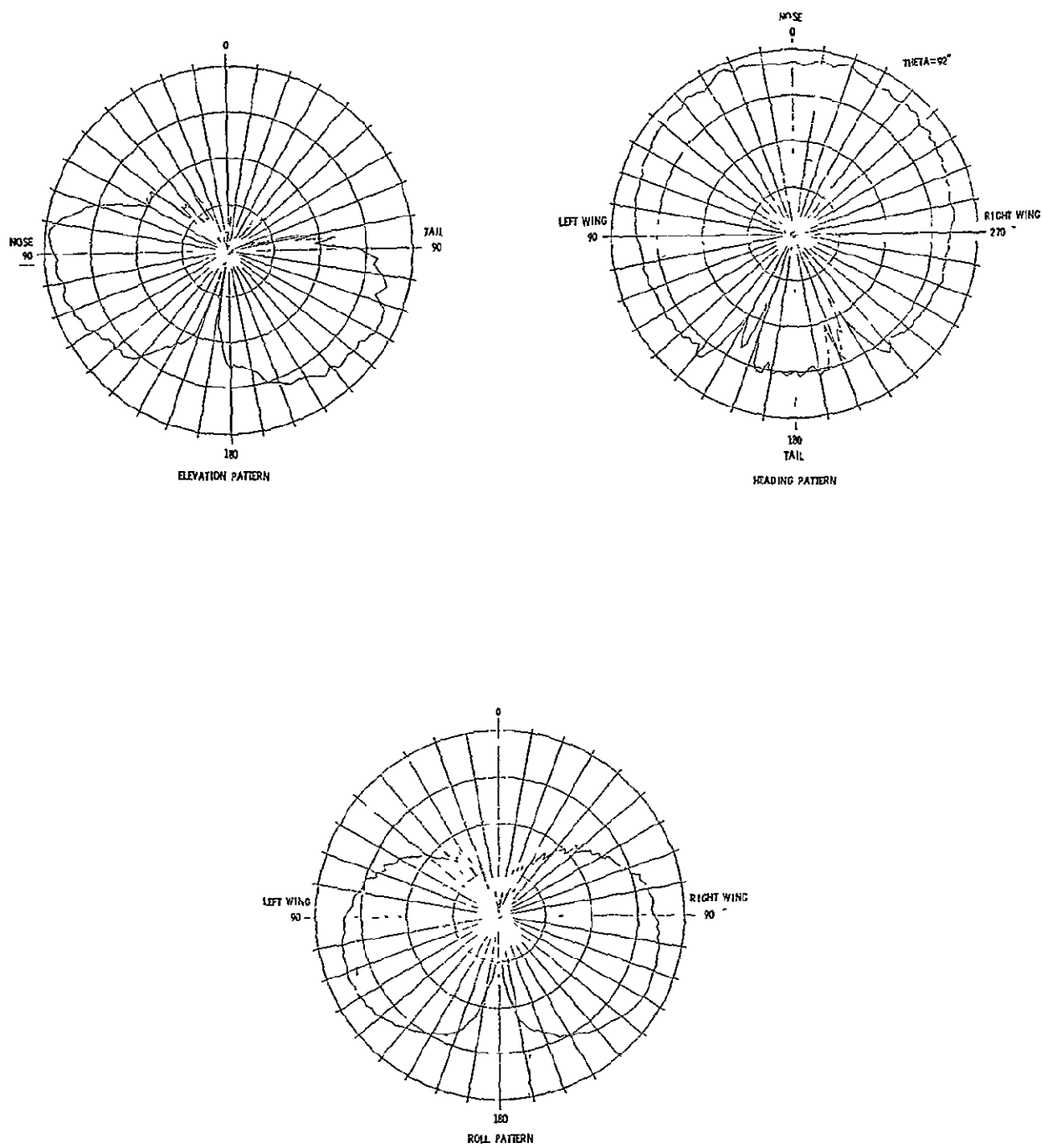

(j) Monopole at station 222 on bottom fuselage.

Figure 9.- Continued.

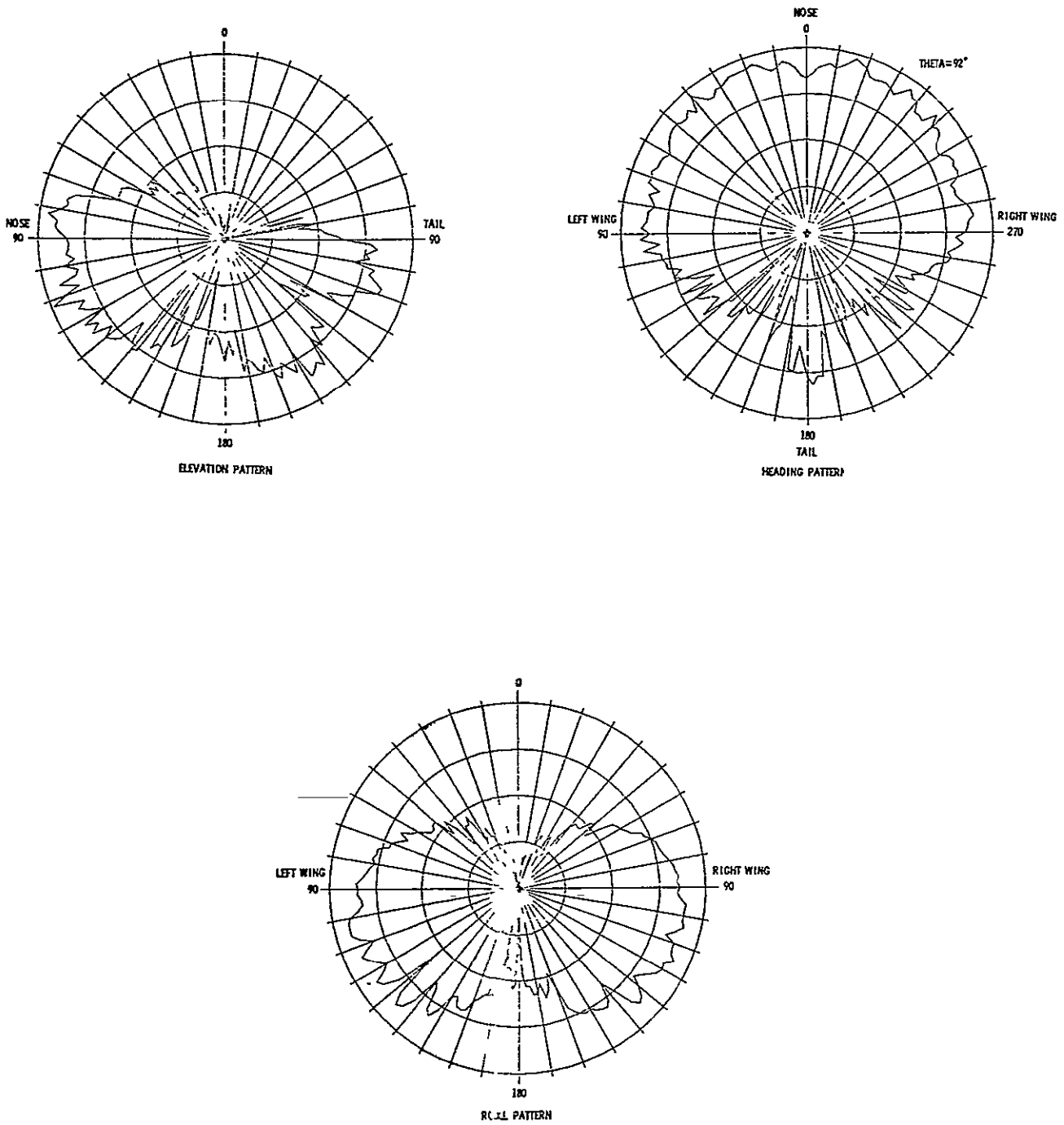

(k) Monopole at station 222 on bottom fuselage with landing gear.

Figure 9.- Continued.

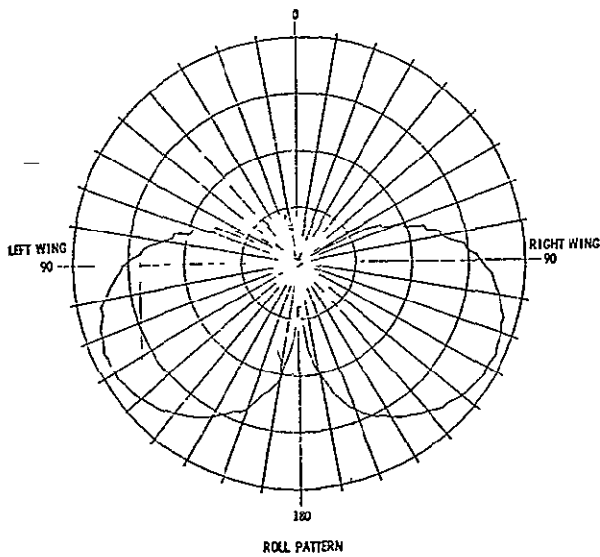
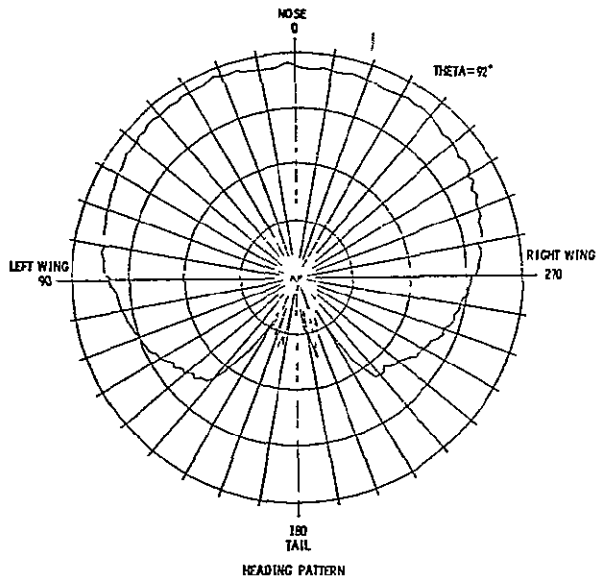
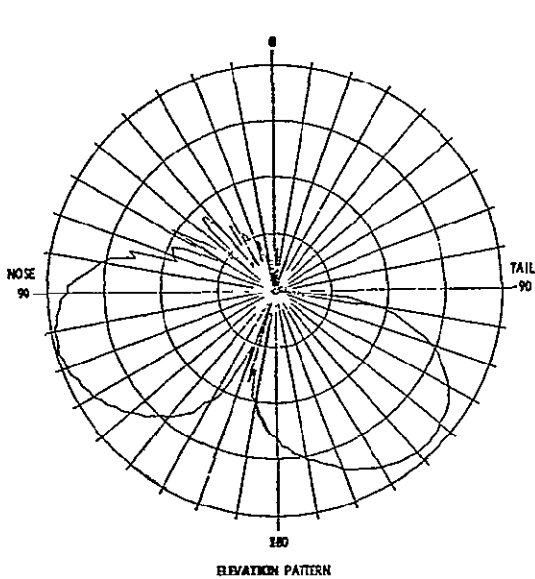

(1) Horizontally polarized coaxial fed slot antenna at station 222 on bottom fuselage.

Figure 9.- Continued.



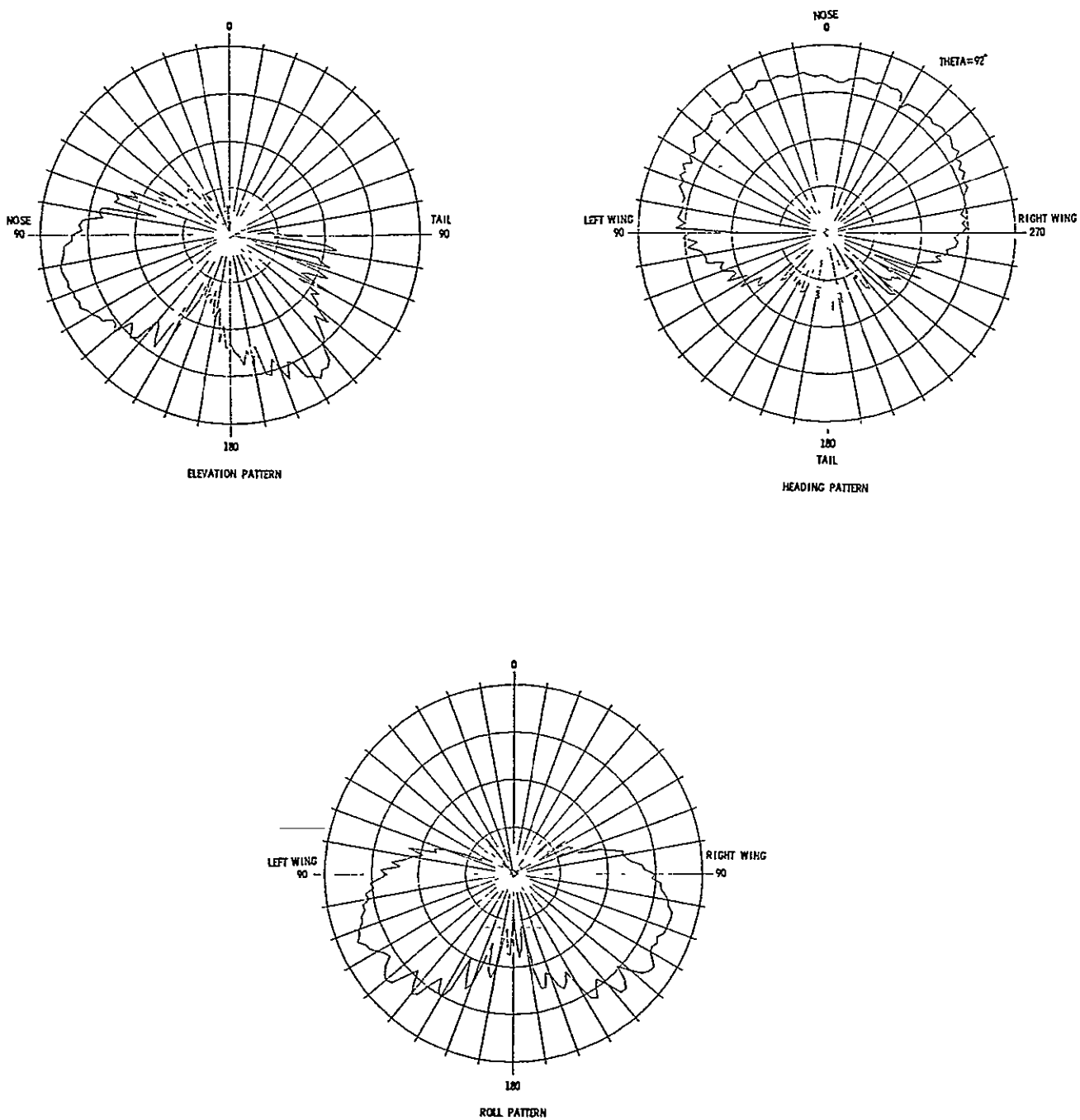

- (m) Horizontally polarized coaxial fed slot antenna at station 222 on bottom fuselage with landing gear.

Figure 9.- Continued.

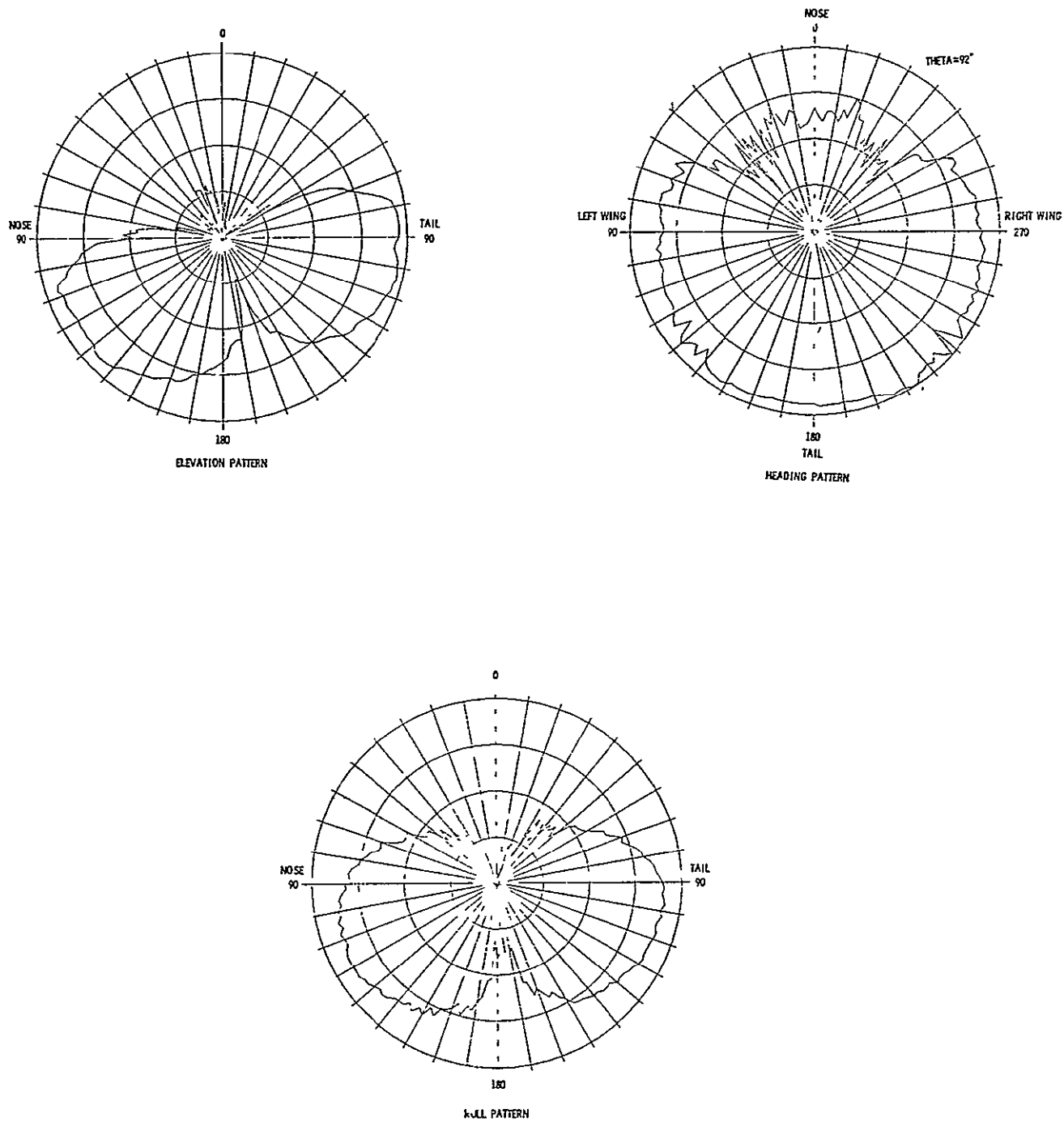

(n) Monopole at station 950 on bottom fuselage.

Figure 9.- Continued.

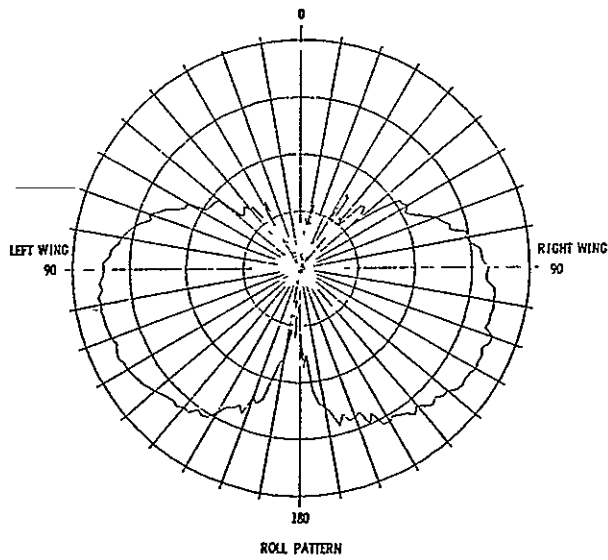
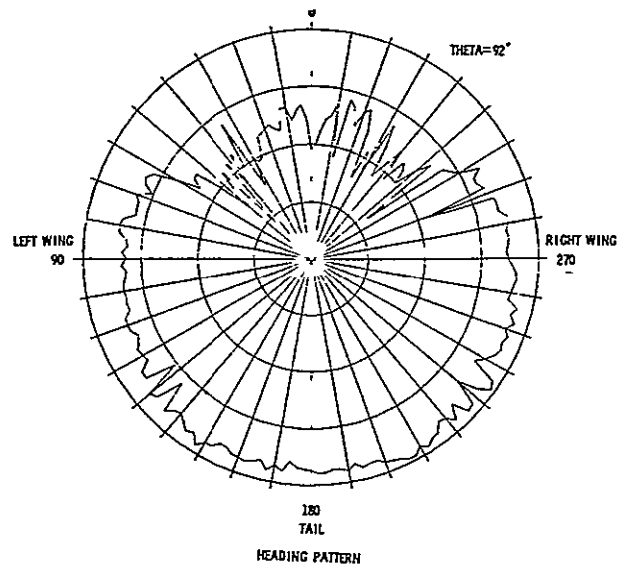
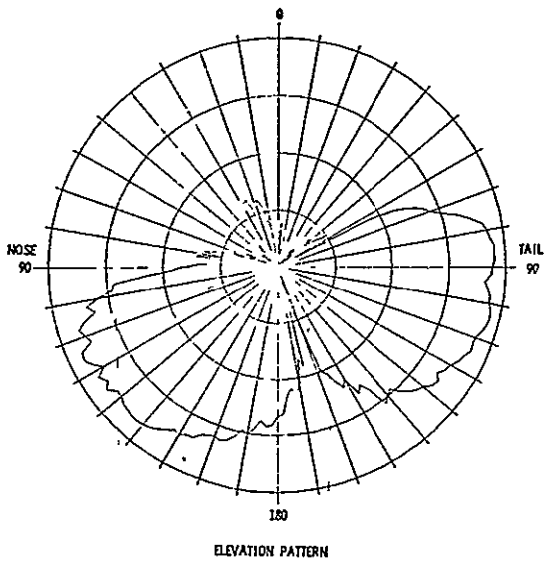

(o) Monopole at station 950 on bottom fuselage with landing gear.

Figure 9.- Continued.



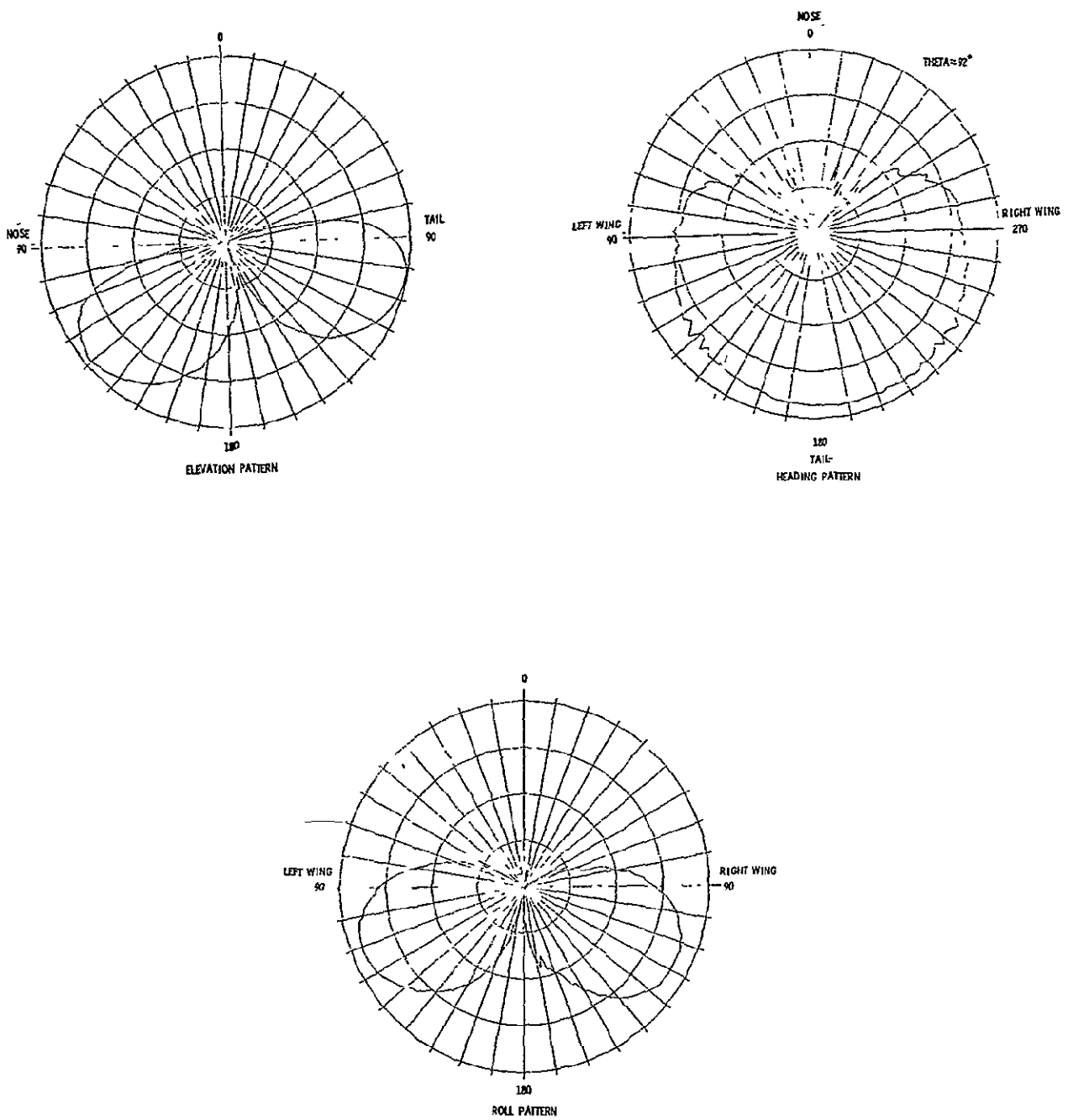

(p) Horizontally polarized coaxial fed slot antenna at station 950 on bottom fuselage.

Figure 9.- Continued.

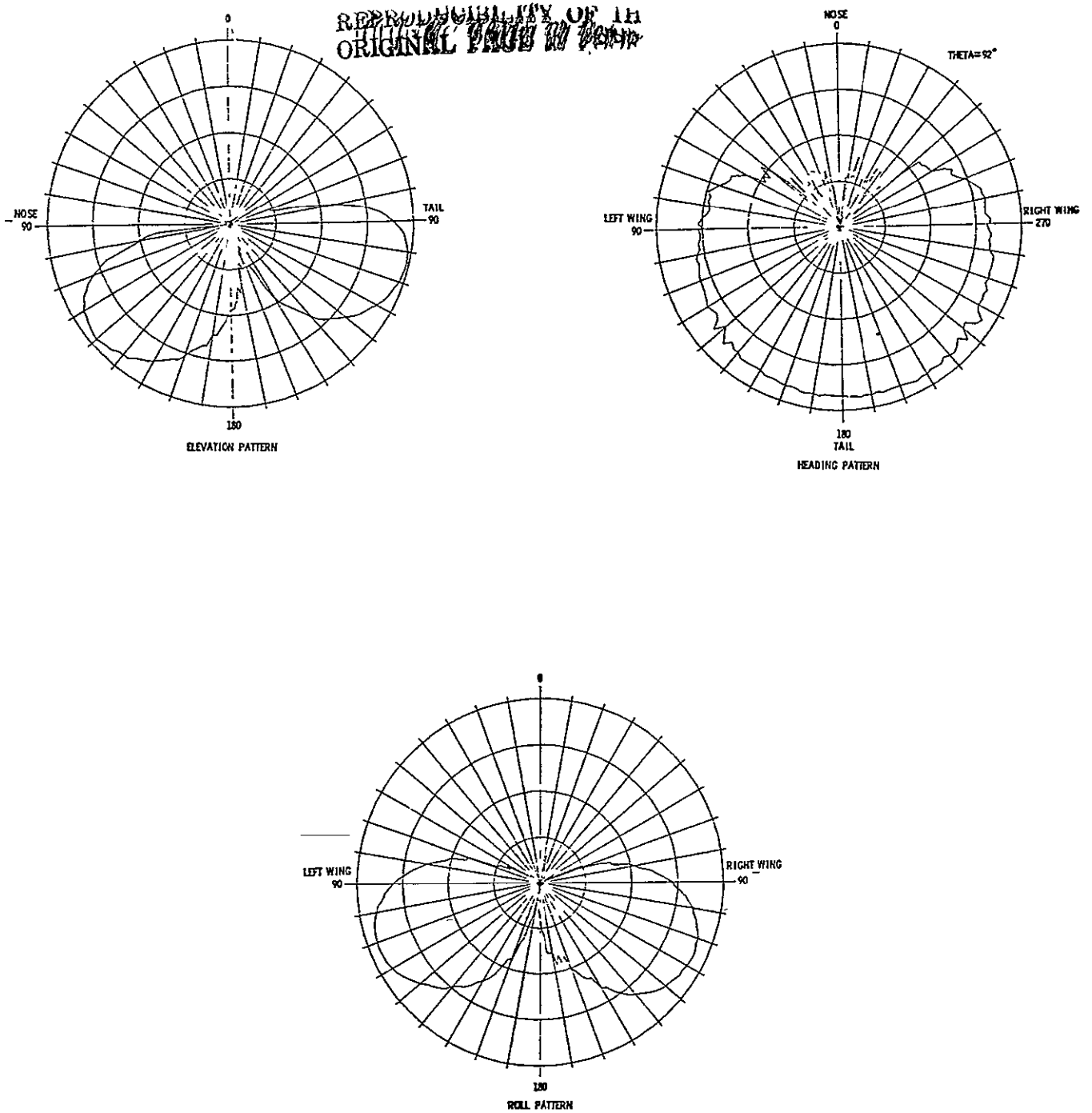

- (q) Horizontally polarized coaxial fed slot antenna at station 950 on bottom fuselage with landing gear.

Figure 9.- Concluded.

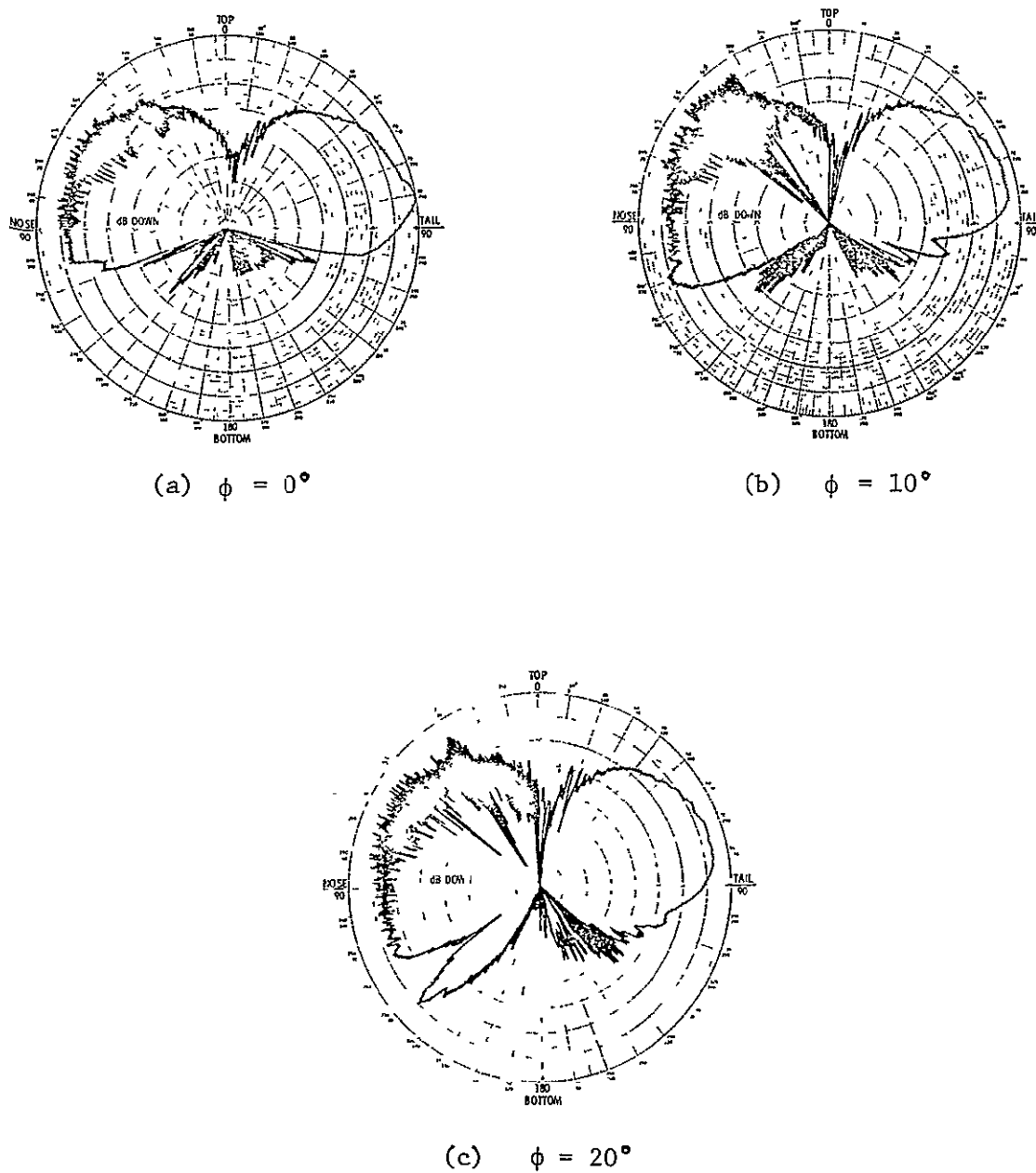
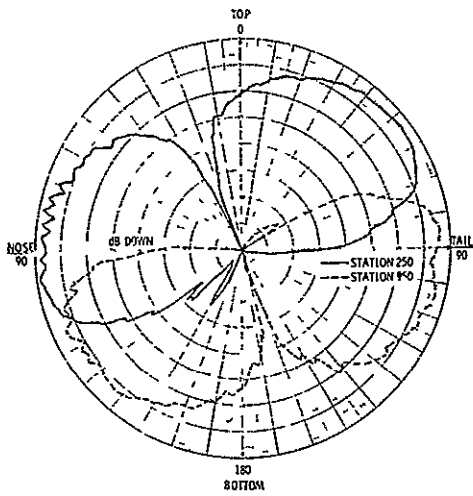
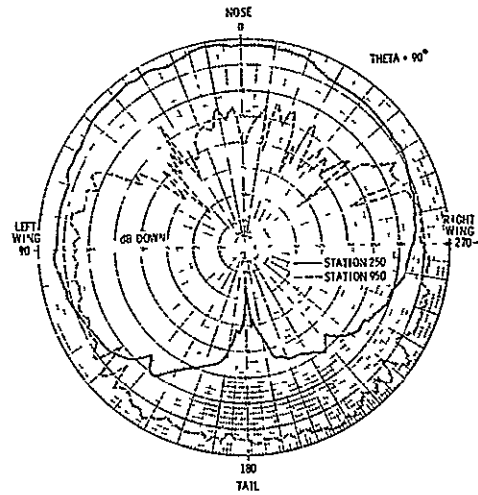

Figure 10.- Elevation plane patterns as a function of a azimuth angle ( $\phi$ ) for a monopole mounted on vertical stabilizer of one-eleventh scale model of Boeing 737.





(a) Elevation



(b) Heading

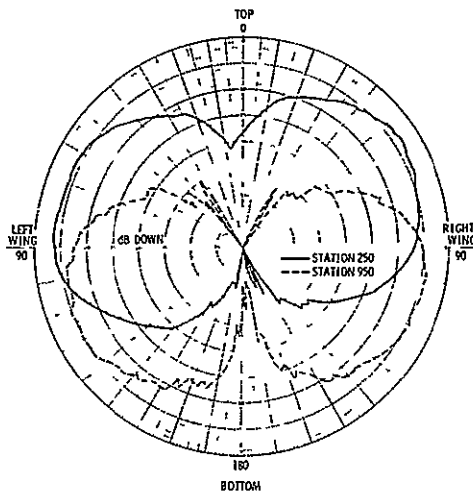

(c) Roll

Figure 11.- Principal plane patterns for vertically polarized monopoles located at stations 250 and 950 on one-eleventh scale model of Boeing 737.

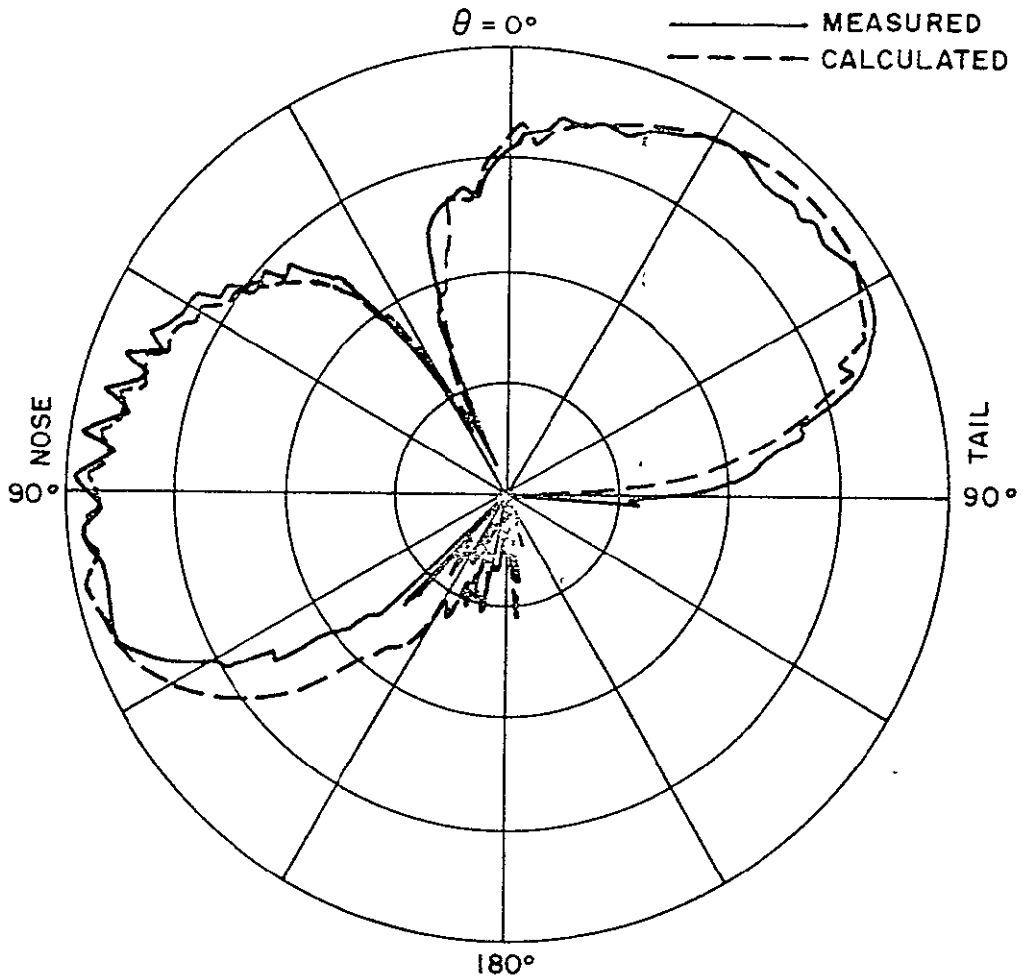

(a) Elevation

Figure 12.- Antenna patterns of a quarter wavelength monopole at station 220 on top fuselage of a Boeing 737.

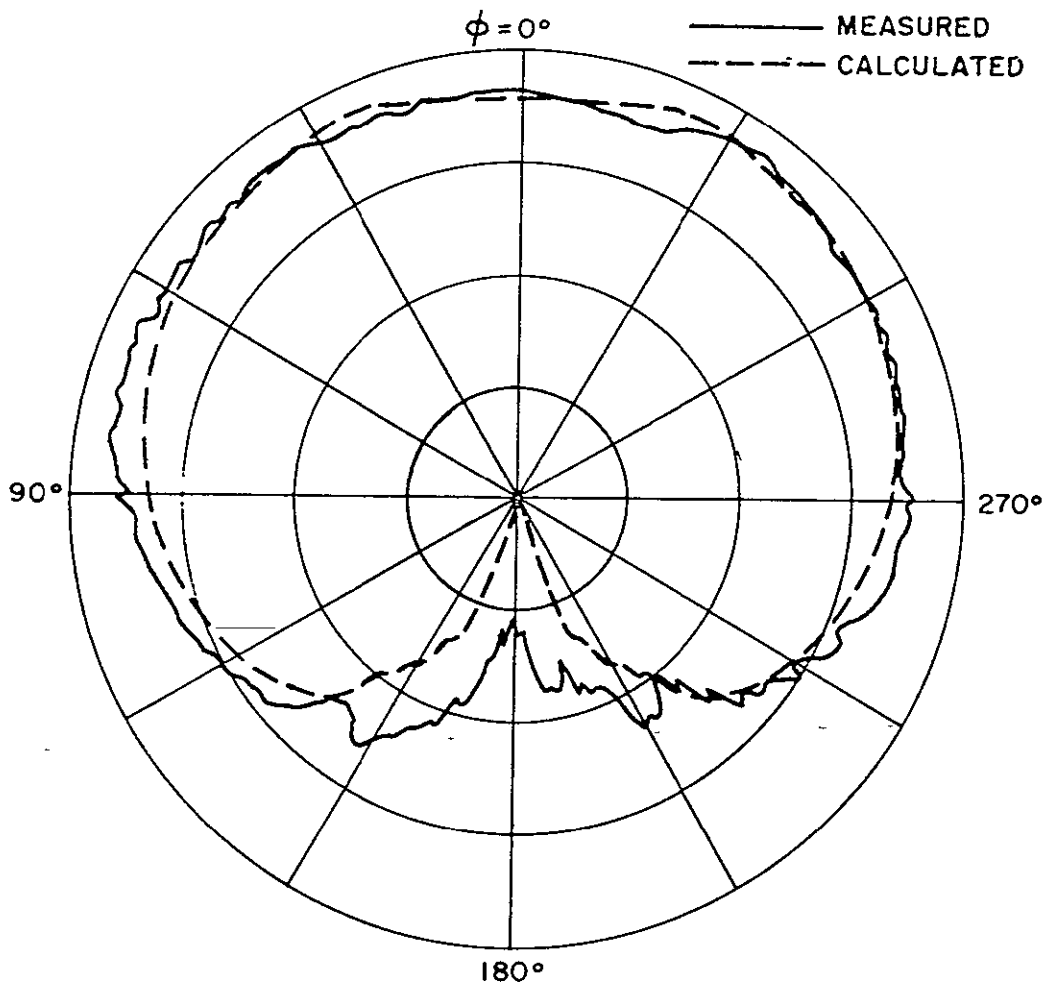

(b) Heading ( $\theta = 92^\circ$ )

Figure 12.- Continued .



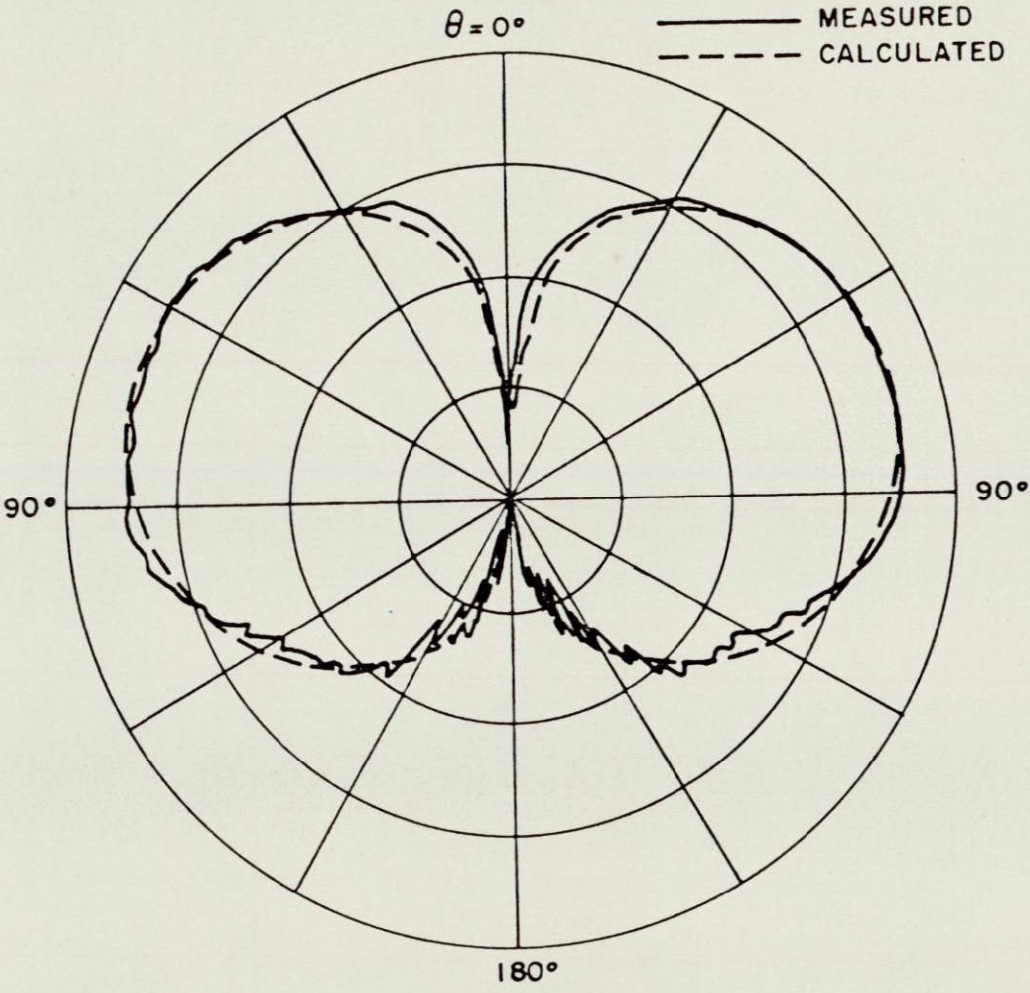

(c) Roll

Figure 12.- Concluded .



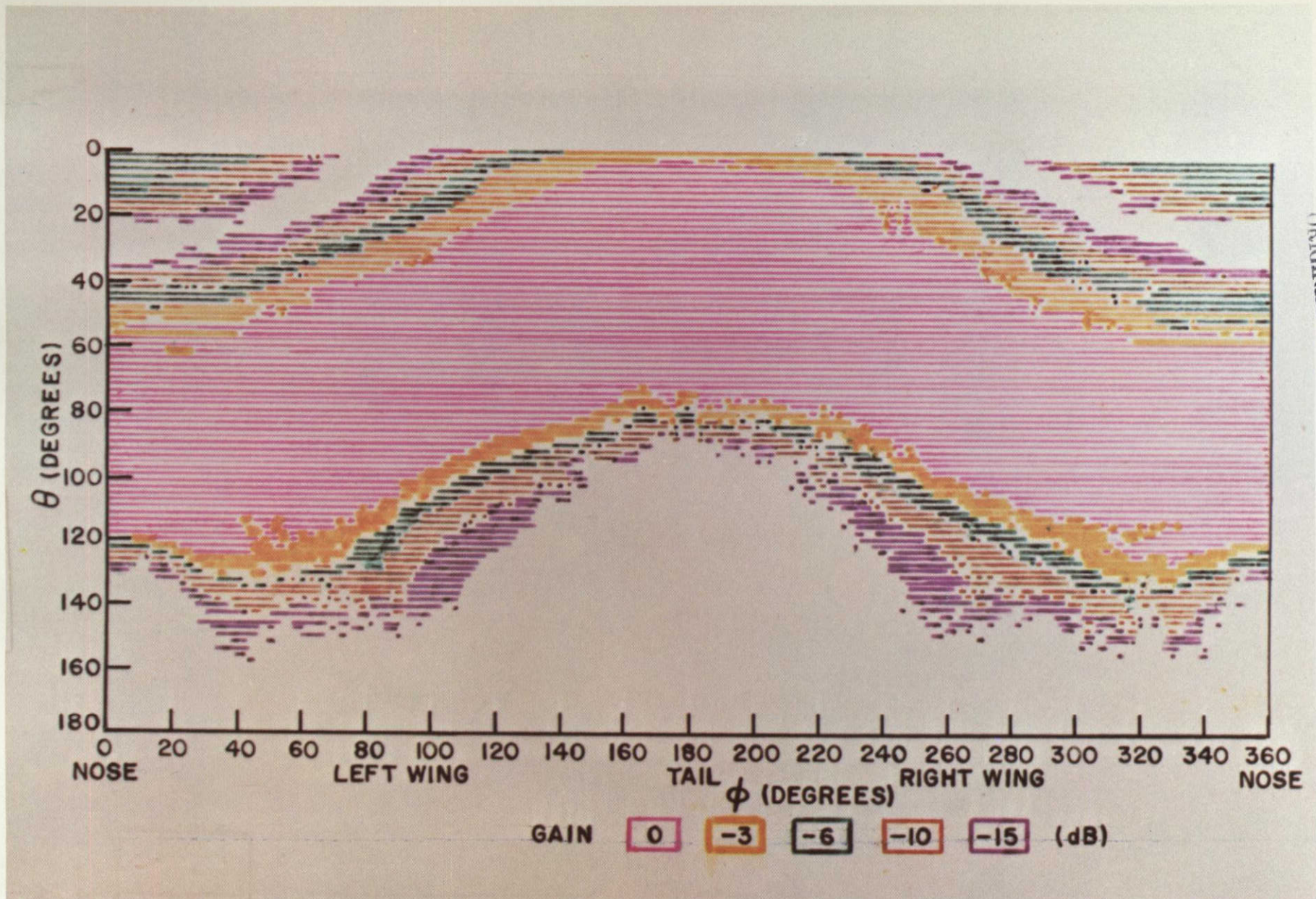

REPRODUCIBILITY OF THE  
 ORIGINAL PAPER FOR

Figure 13(a) - Measured volumetric directive gain pattern of a one-quarter wavelength monopole mounted at station 220 on top of a one-eleventh scale model of a Boeing 737 aircraft.



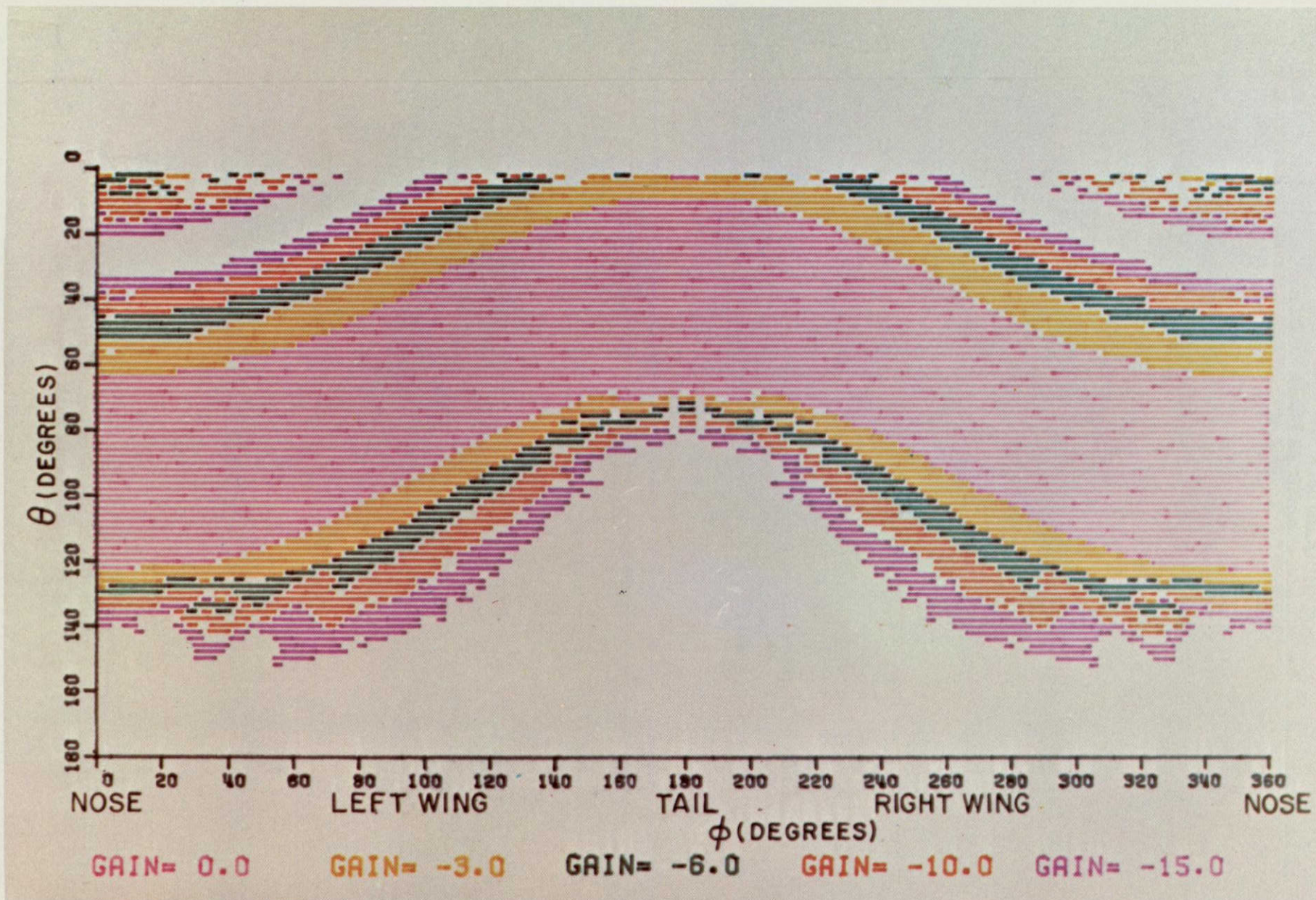
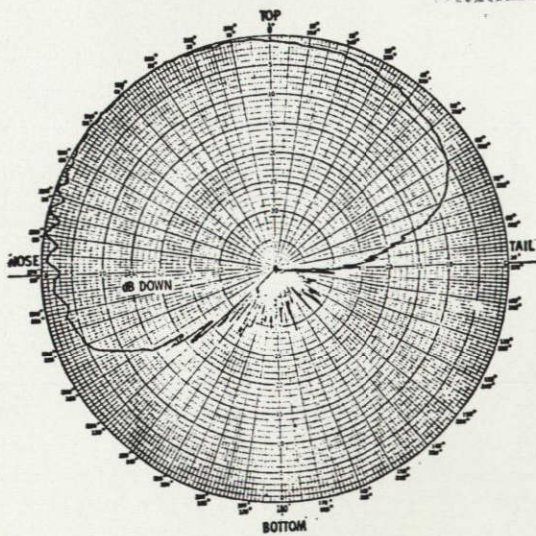
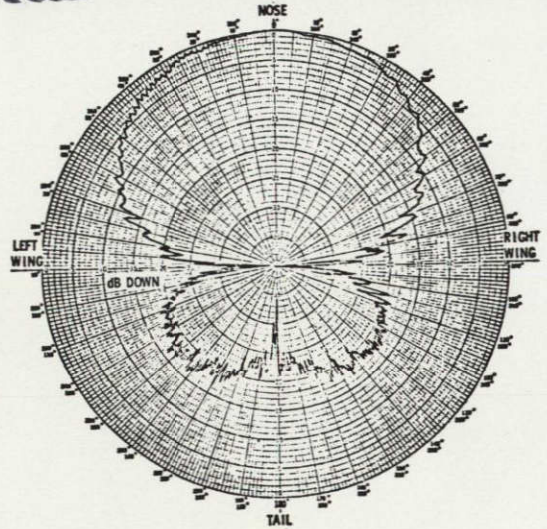

Figure 13(b).- Calculated volumetric directive gain pattern of a one-quarter wavelength monopole mounted at station 220 on top of a one-eleventh scale model of a Boeing 737 aircraft.





(a) Elevation



(b) Heading

Figure 14.- Principal plane patterns for vertically polarized circumferential waveguide at station 220 on top fuselage of a one-eleventh scale model of a Boeing 737.

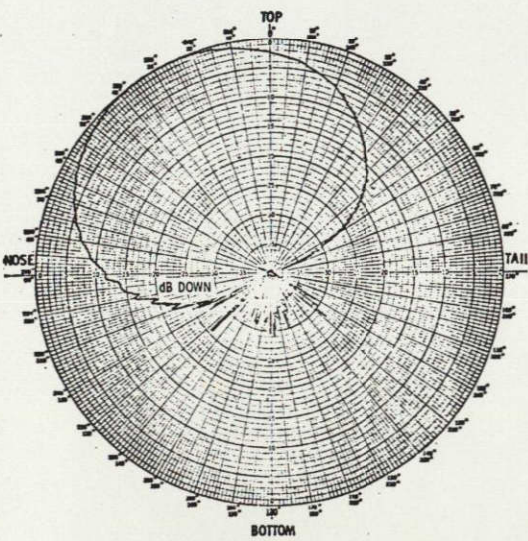

(a) Elevation

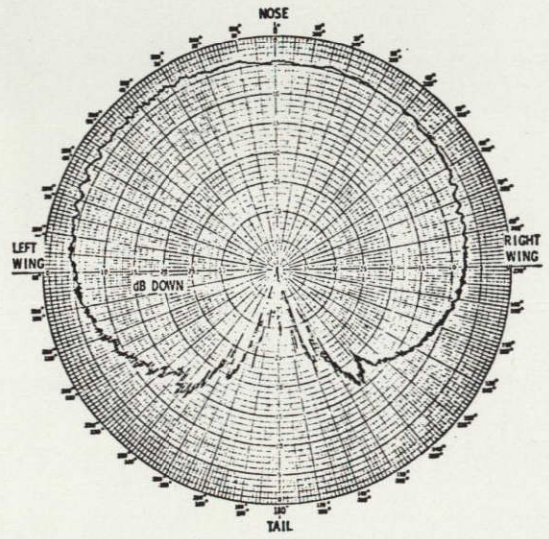

(b) Heading

Figure 15.- Principal plane patterns for a horizontally polarized axial waveguide at station 220 on top fuselage of a one-eleventh scale model of a Boeing 737.

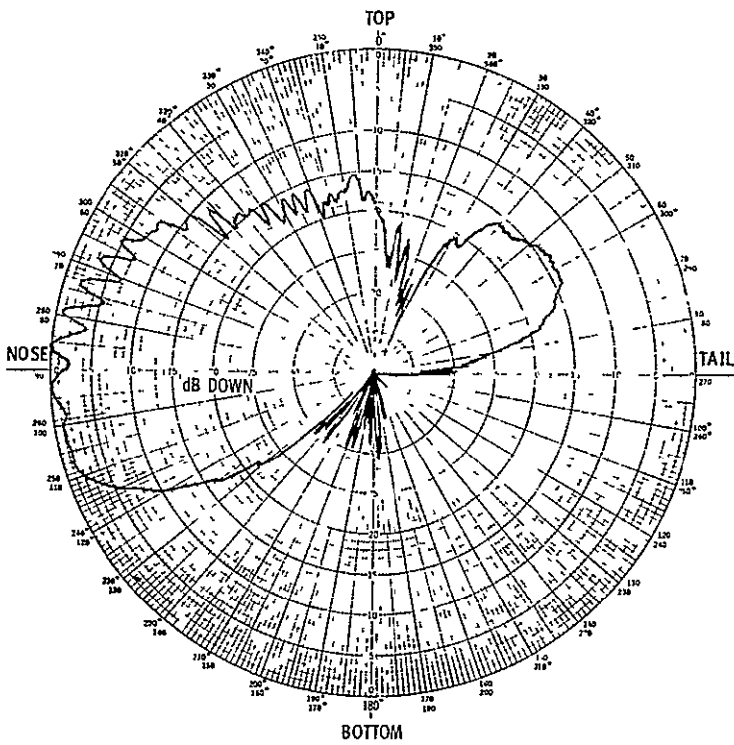

(a) Elevation

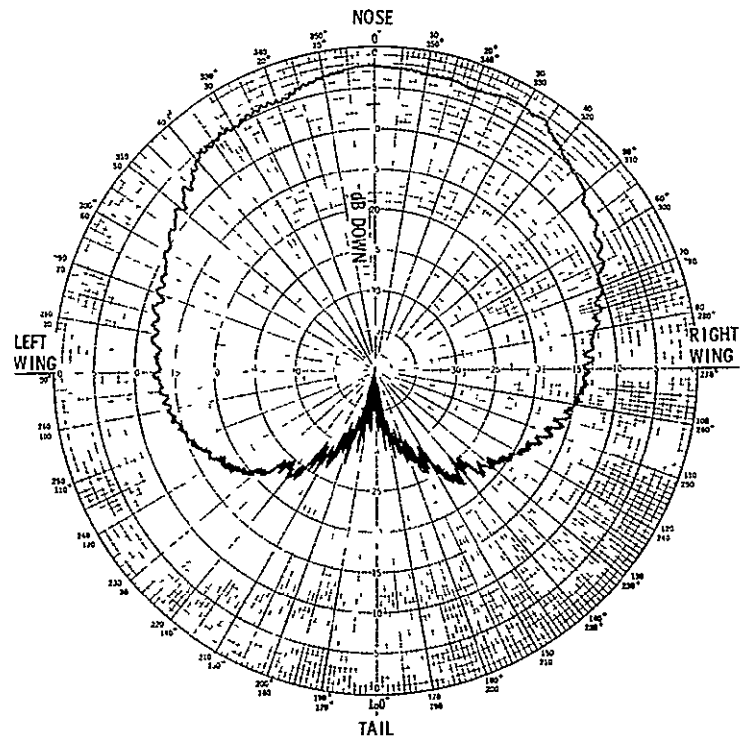

(b) Heading

Figure 16.- Principal plane patterns for monopole with reflectors at station 220 on top fuselage of a one-eleventh scale model of a Boeing 737.

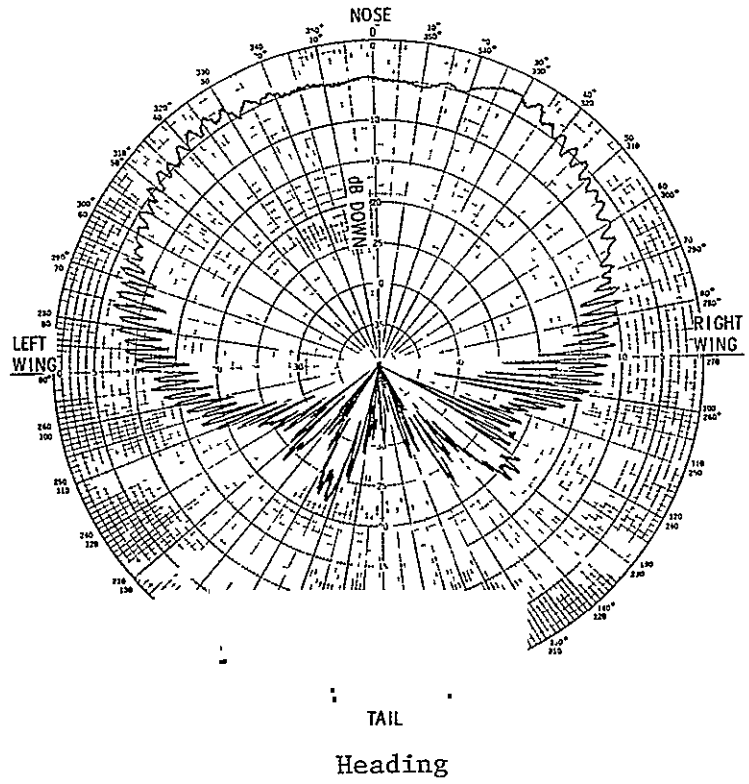
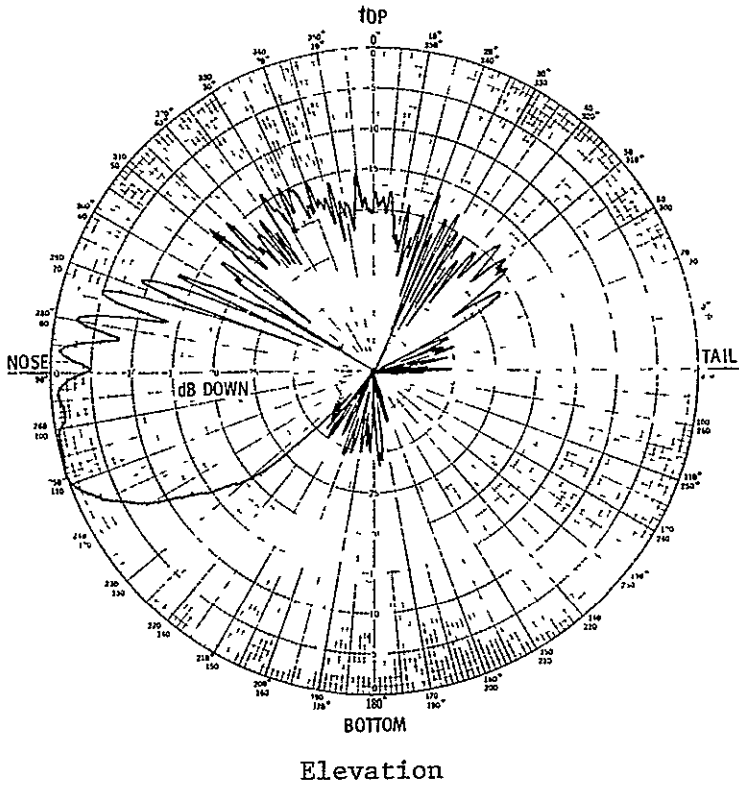

(a) Vertical polarization

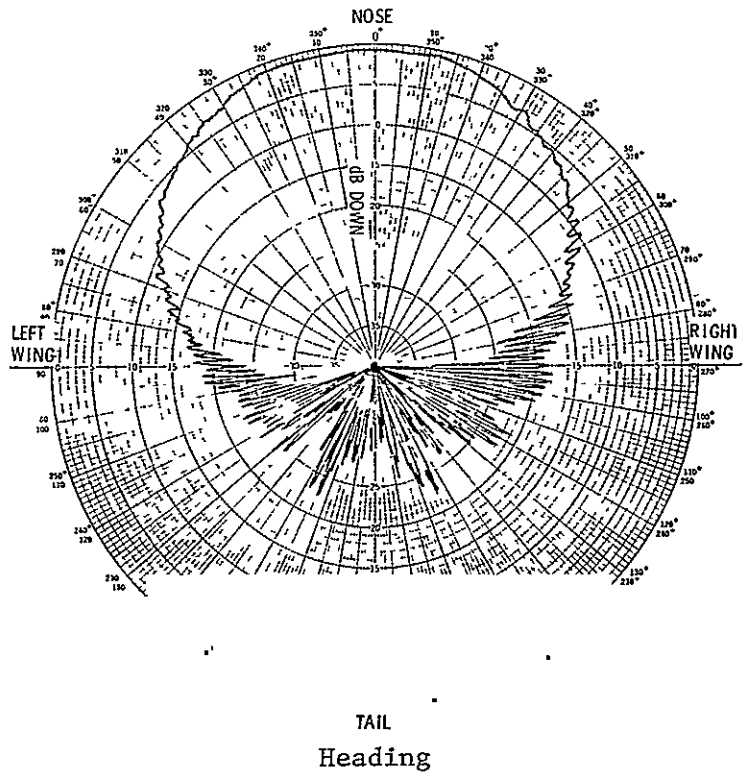
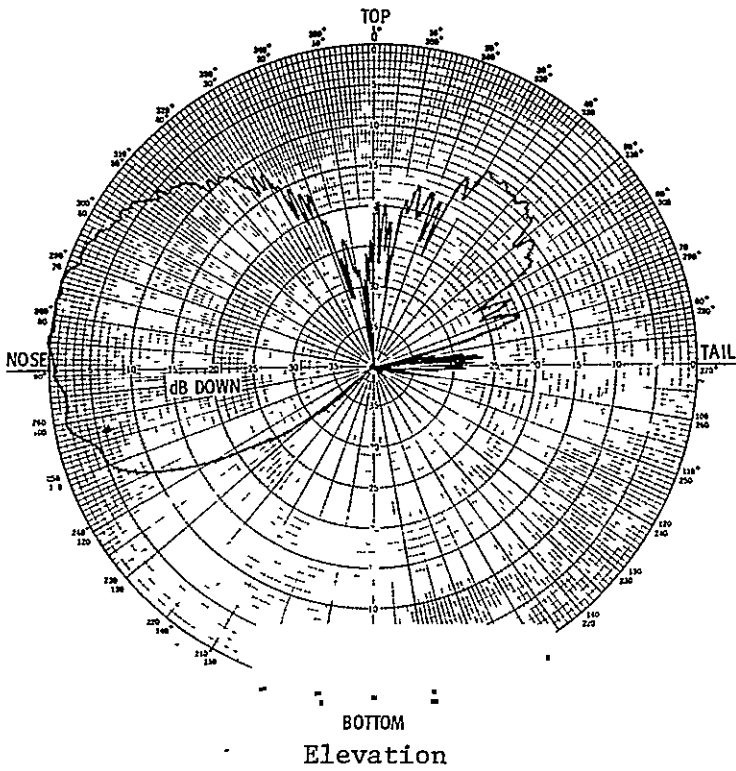

(b) Horizontal polarization

Figure 17.- Principal plane patterns for a circular waveguide at station 220 on top fuselage of a one-eleventh scale model of a Boeing 737.



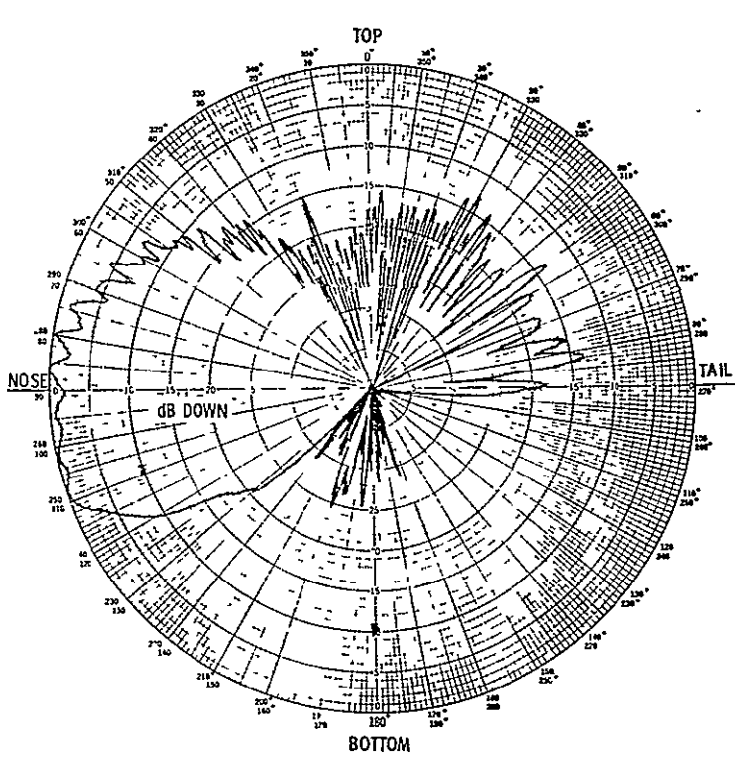

Elevation

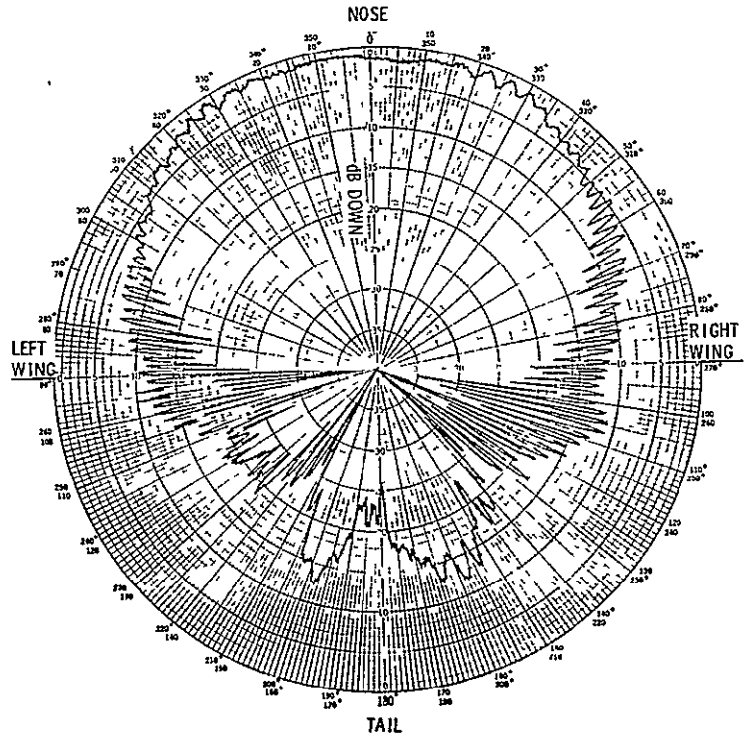

Heading

(c) Circular polarization

Figure 17.- Concluded.

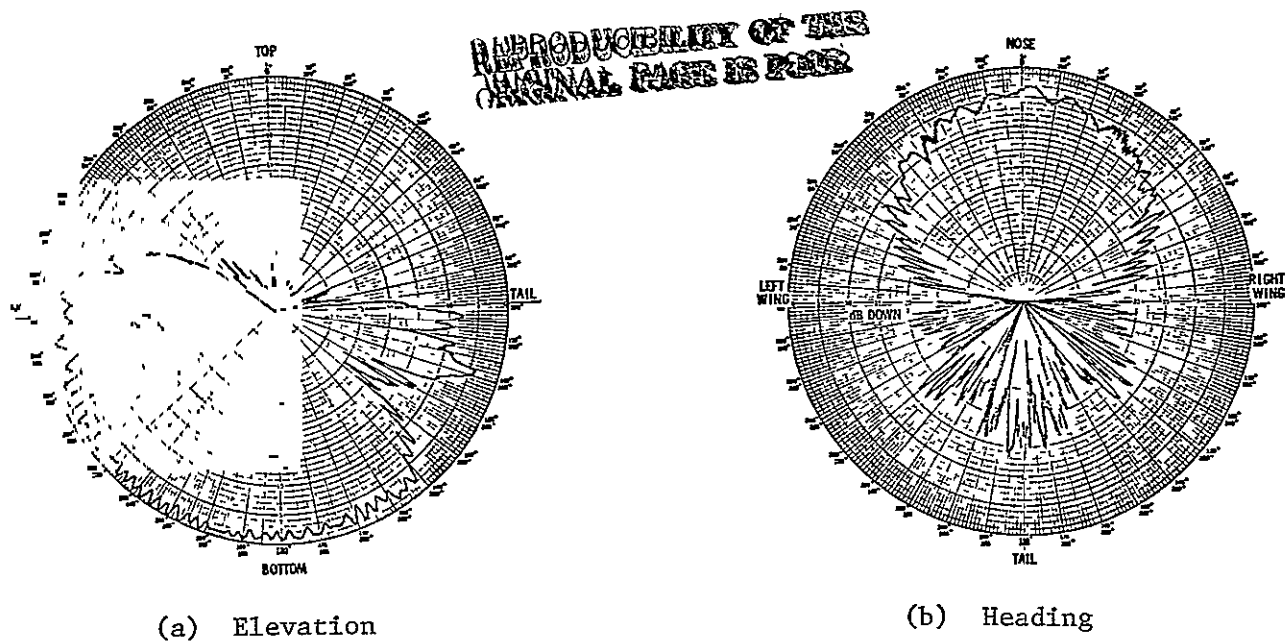

Figure 18.- Principal plane patterns for vertically polarized circumferential waveguide at station 222 on bottom fuselage of a one-eleventh scale model of a Boeing 737.

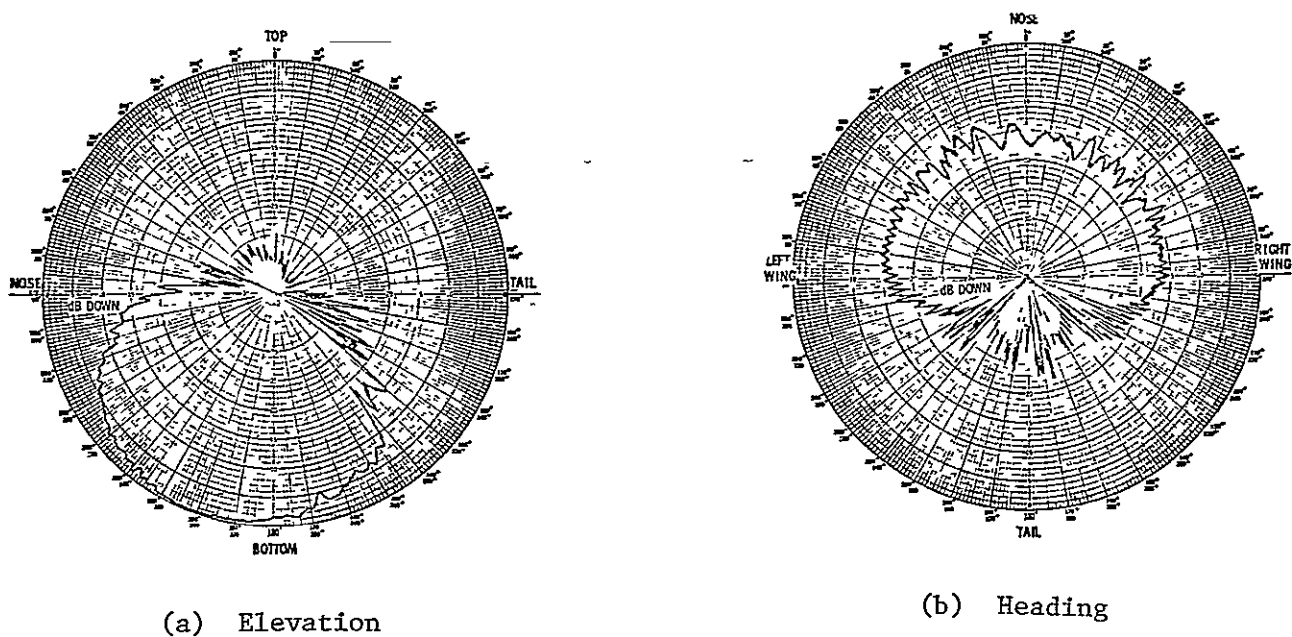

Figure 19.- Principal plane patterns for horizontally polarized axial waveguide at station 222 on bottom fuselage of a one-eleventh scale model of a Boeing 737.

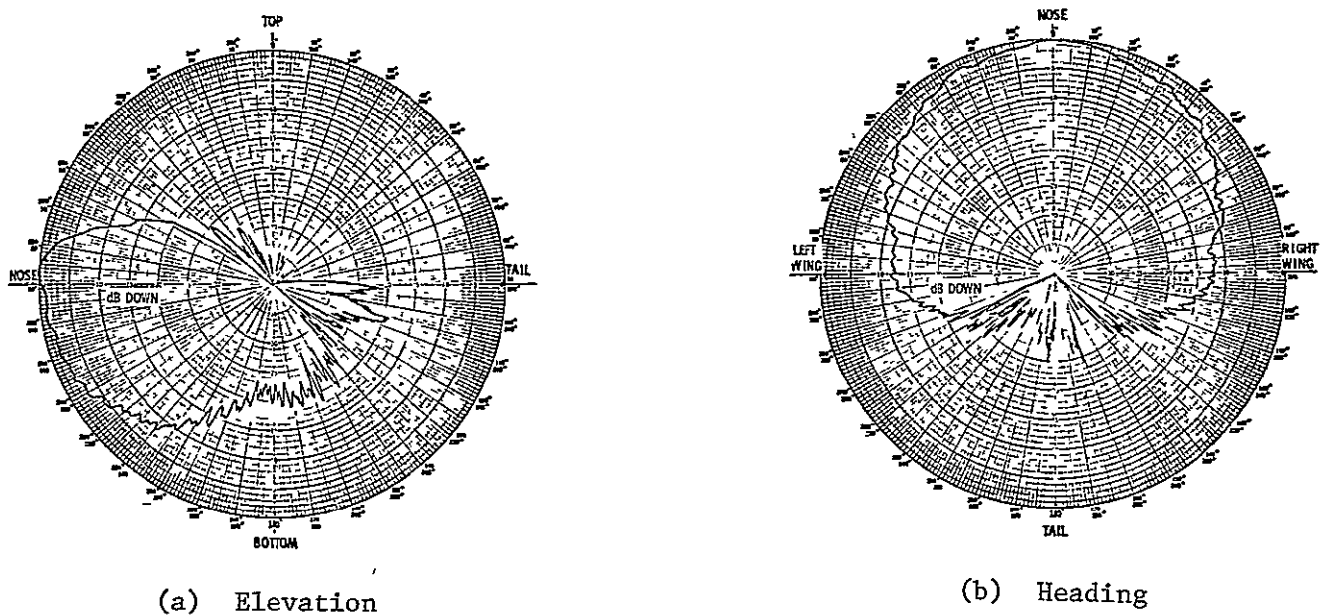
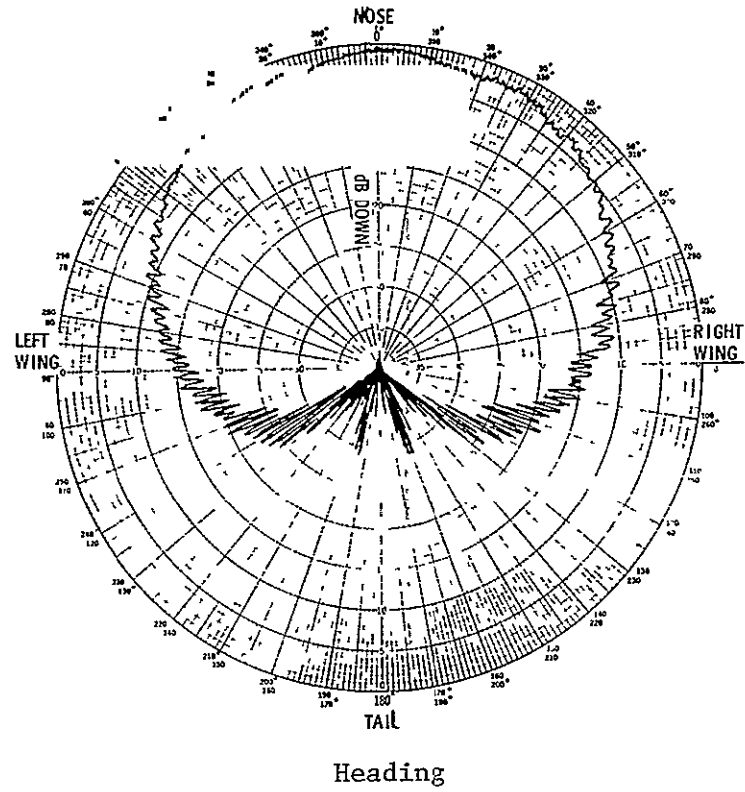
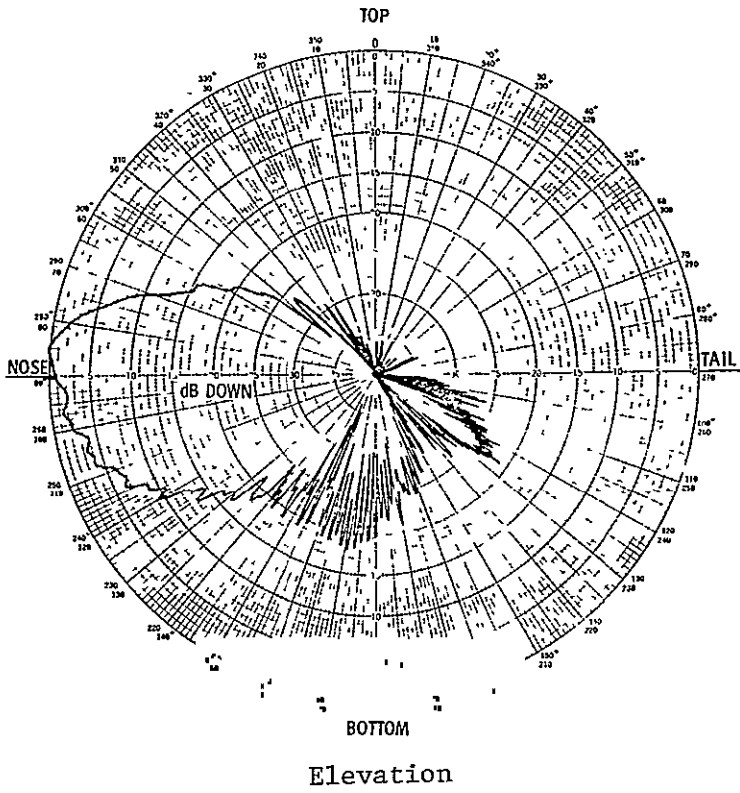
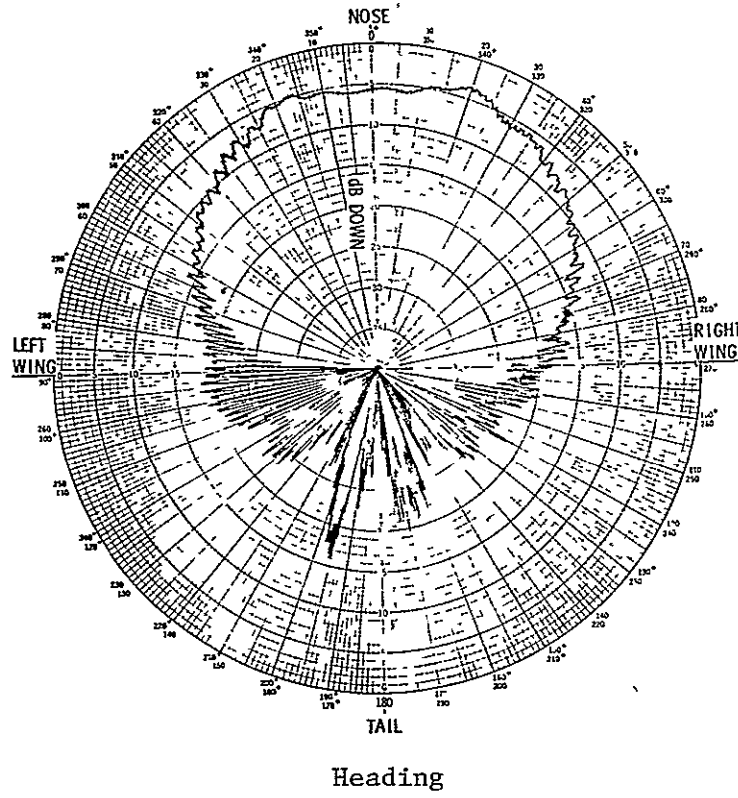
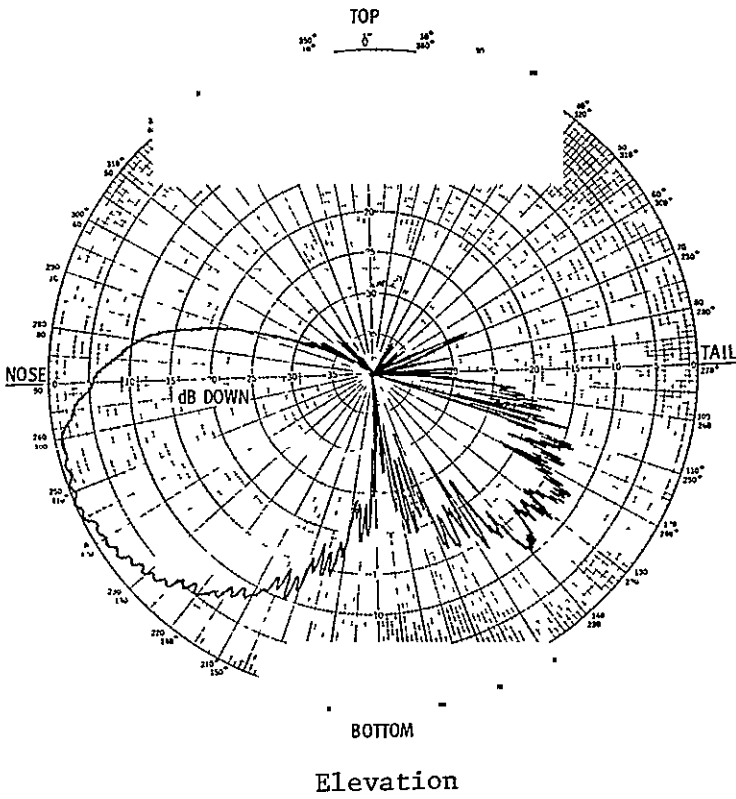

Figure 20.- Principal plane patterns for a monopole with reflectors at station 222 on bottom fuselage of a one-eleventh scale model of a Boeing 737.





(a) Vertical polarization



(b) Horizontal polarization

Figure 21.- Principal plane patterns for a circular waveguide at station 222 on bottom fuselage of a one-eleventh scale model of a Boeing 737.

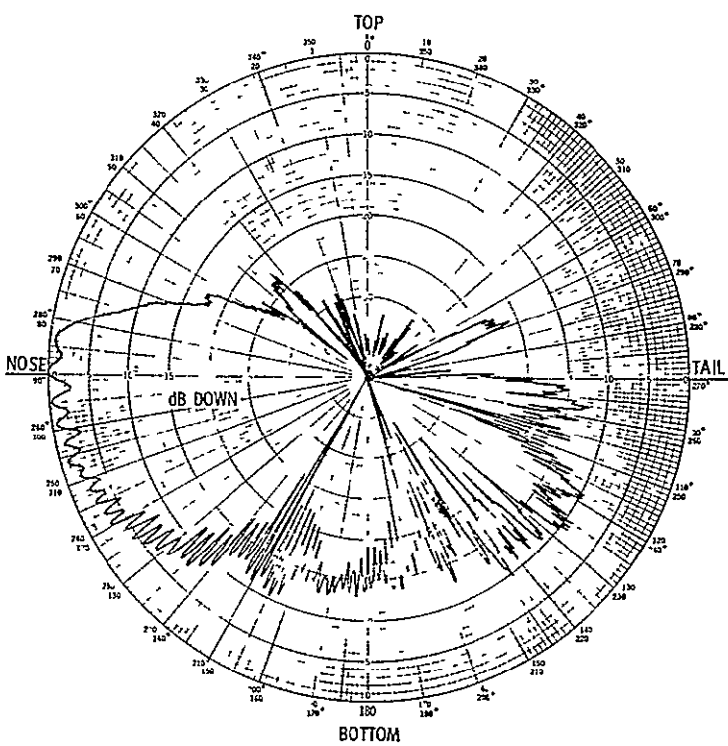

Elevation

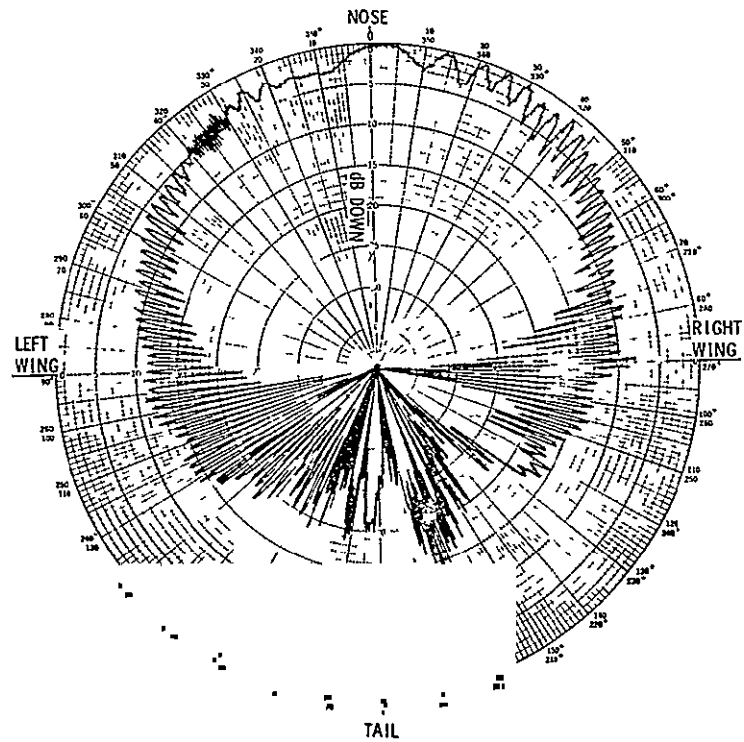

Heading

(c) Circular polarization

Figure 21.- Concluded.

APPENDIX

---

VOLUMETRIC GAIN PLOTS



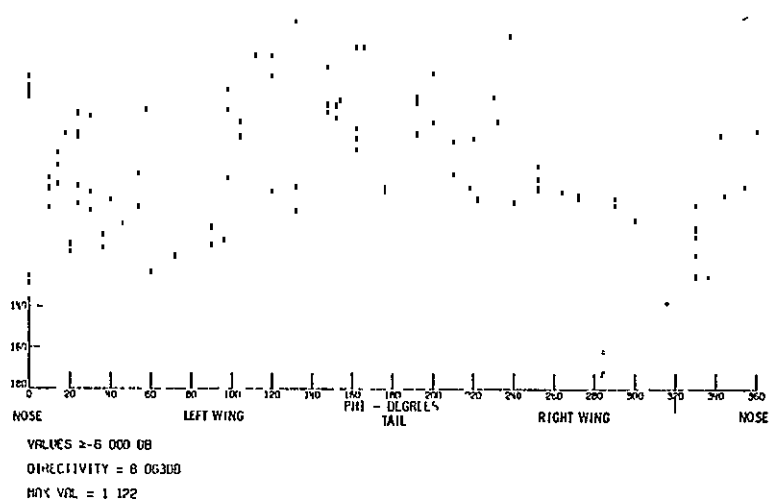
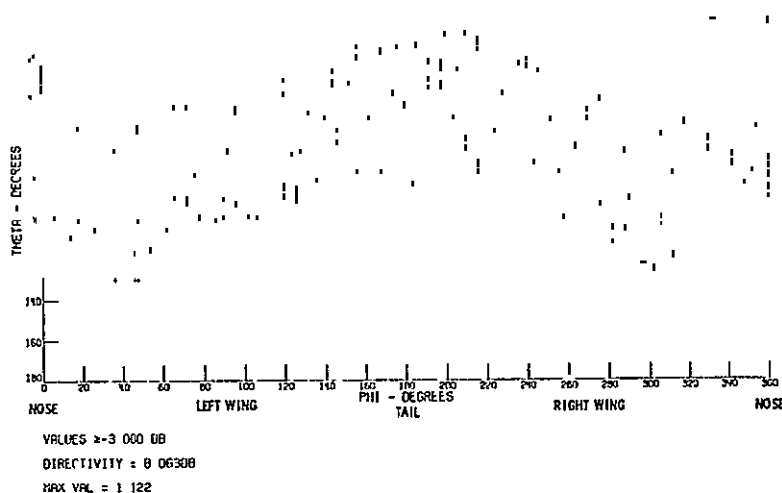
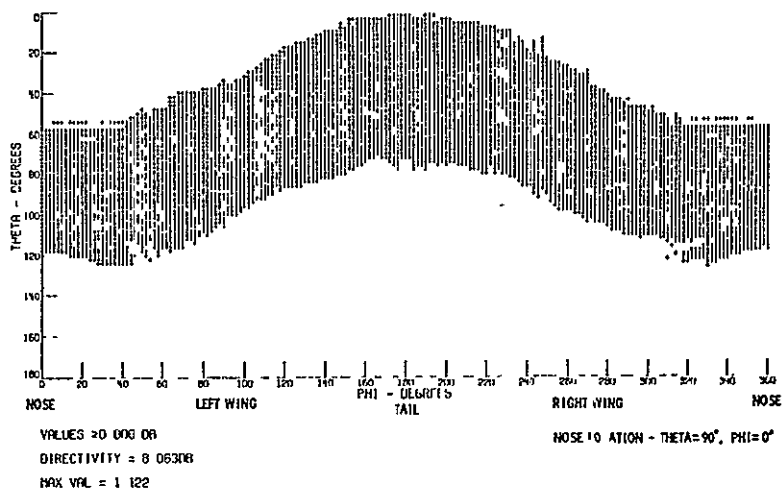

(a) Monopole at station 220 on top fuselage

Figure A-1.- Volumetric plots for omnidirectional antennas on one-eleventh scale model of Boeing 737.

REPRODUCIBILITY OF THE ORIGINAL PAGE IS POOR

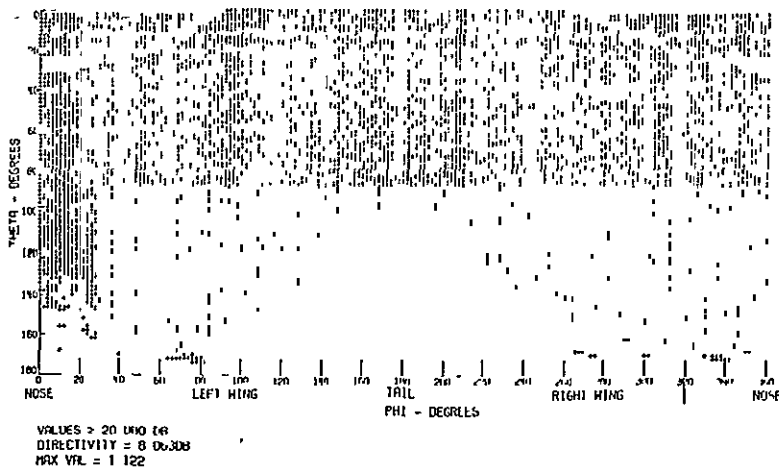
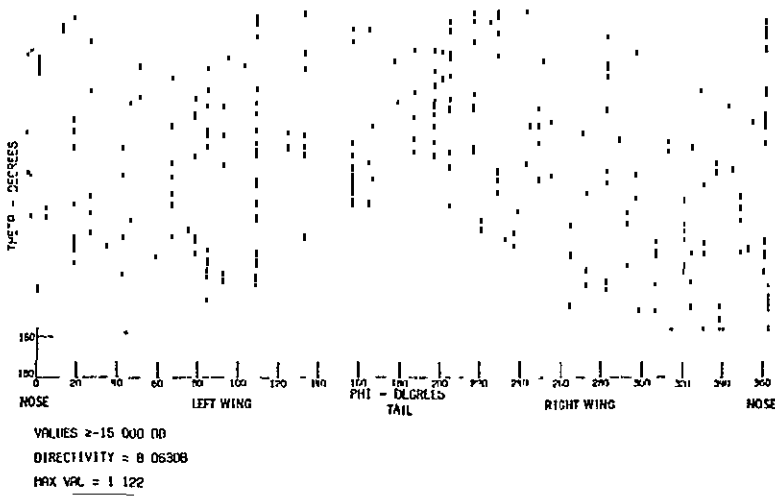
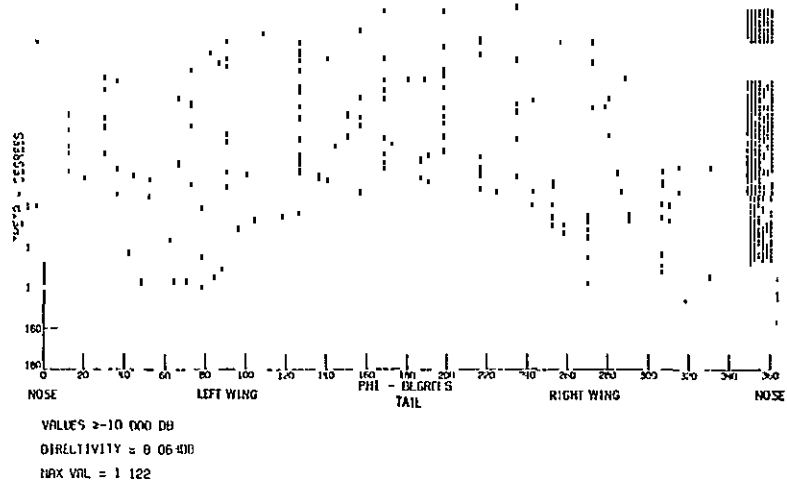

(a) Concluded.

Figure A-1.- Continued.

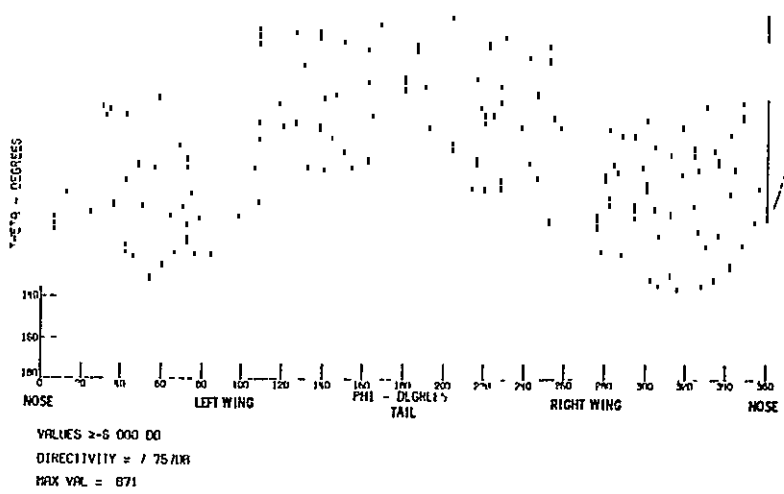
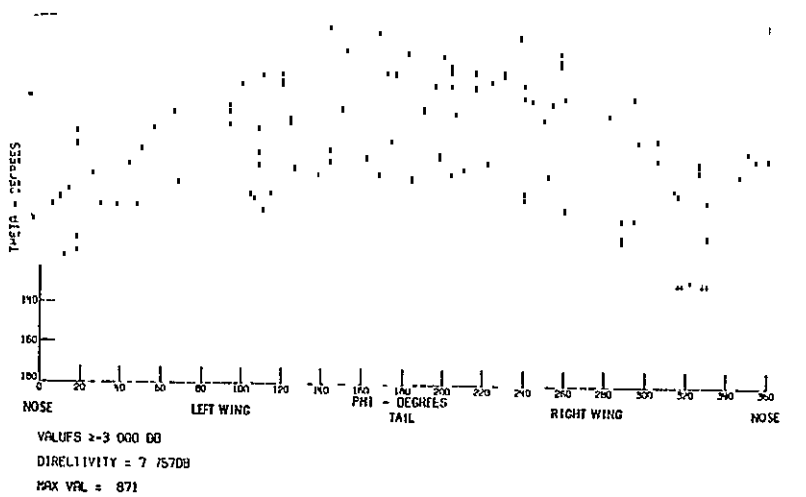
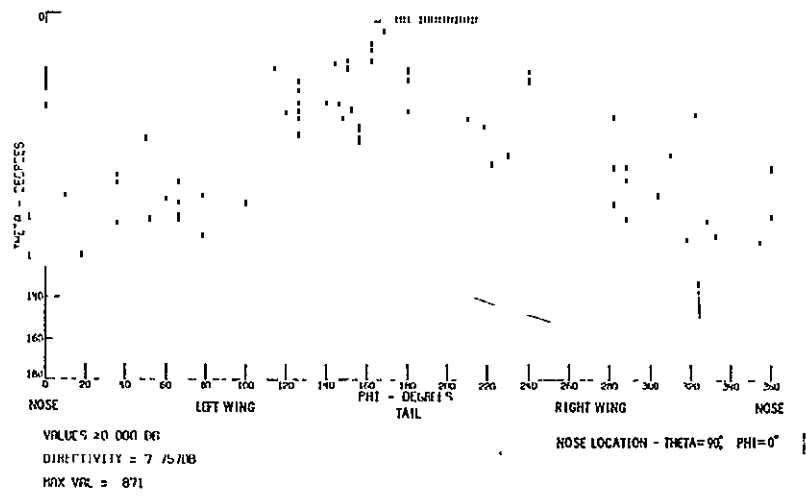

(b) Monopole at station 220 on top fuselage with landing gear.

Figure A-1.- Continued.



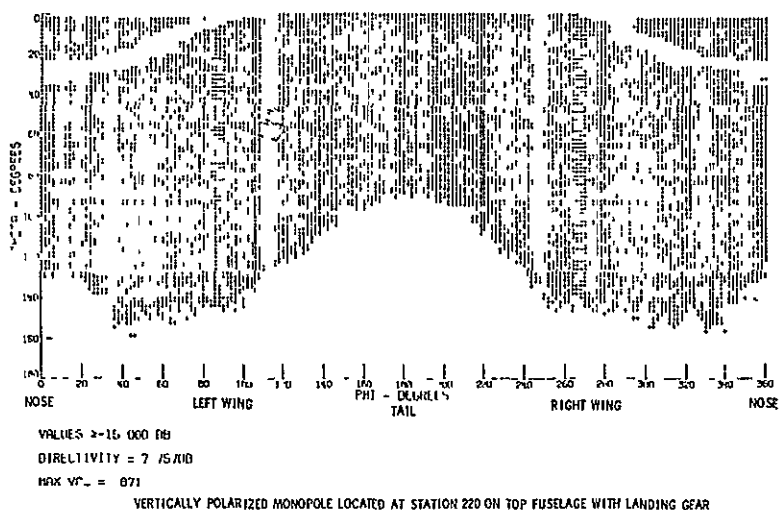
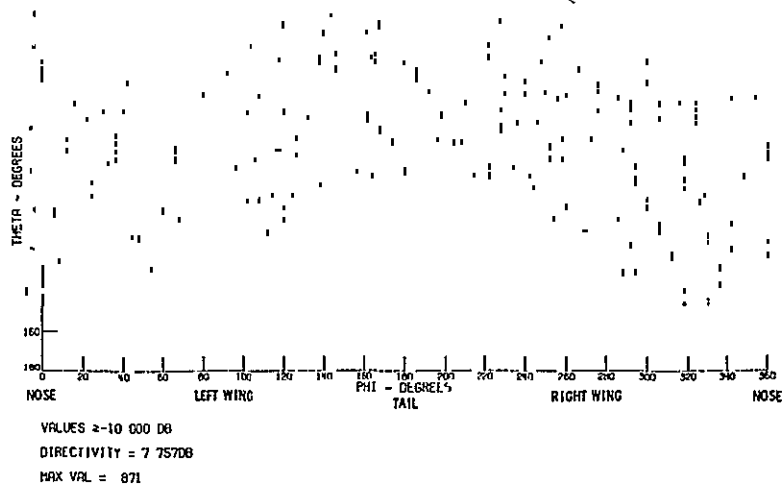

VERTICALLY POLARIZED MONOPOLE LOCATED AT STATION 220 ON TOP FUSELAGE WITH LANDING GEAR

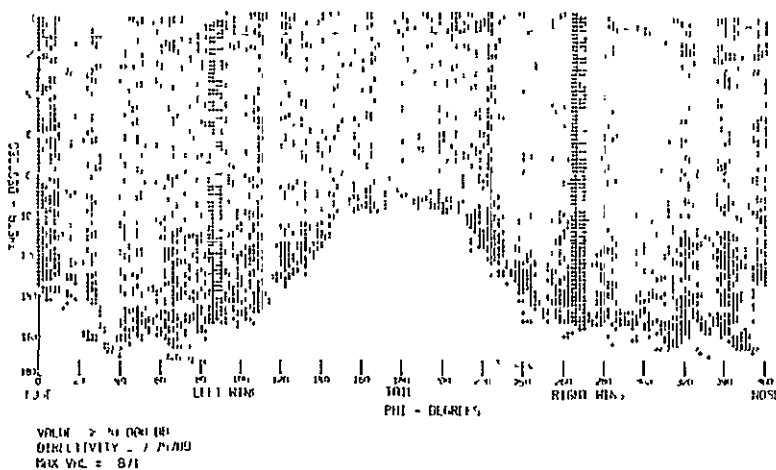

(b) Concluded.

REPRODUCIBILITY OF THIS ORIGINAL PAGE IS F.

Figure A-1.- Continued.

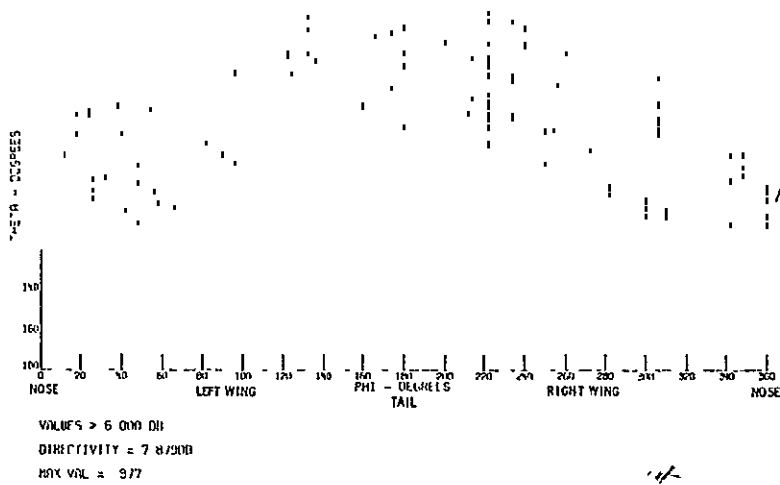
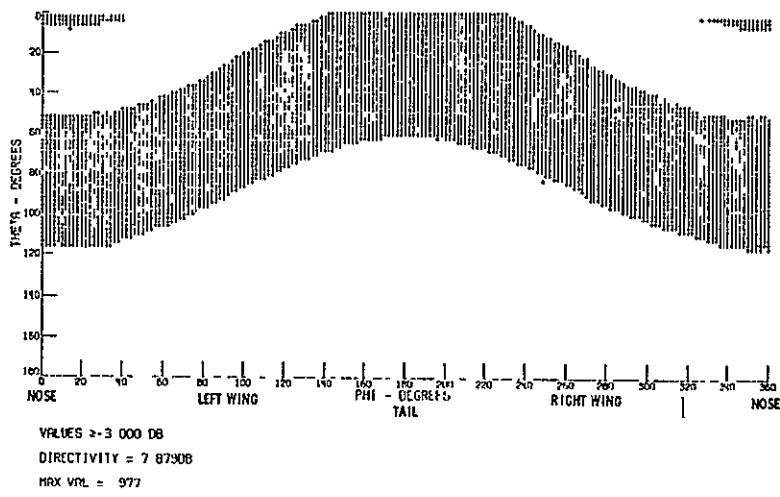
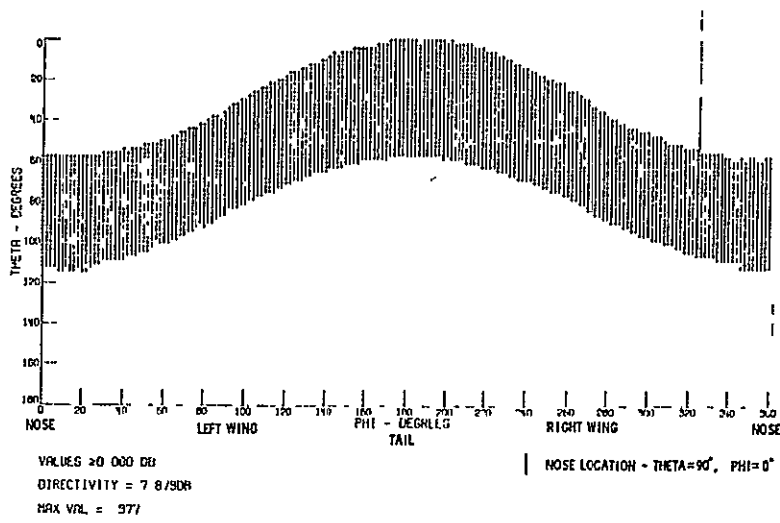

(c) Horizontally polarized coaxial fed slot antenna at station 220.

Figure A-1.- Continued.

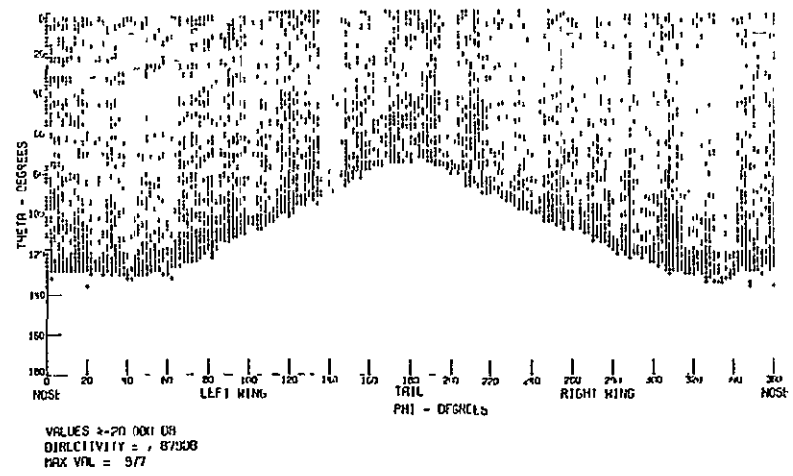
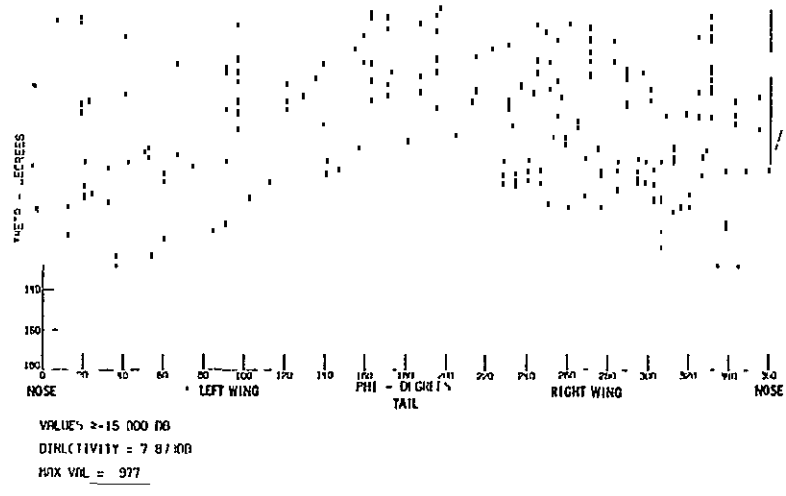
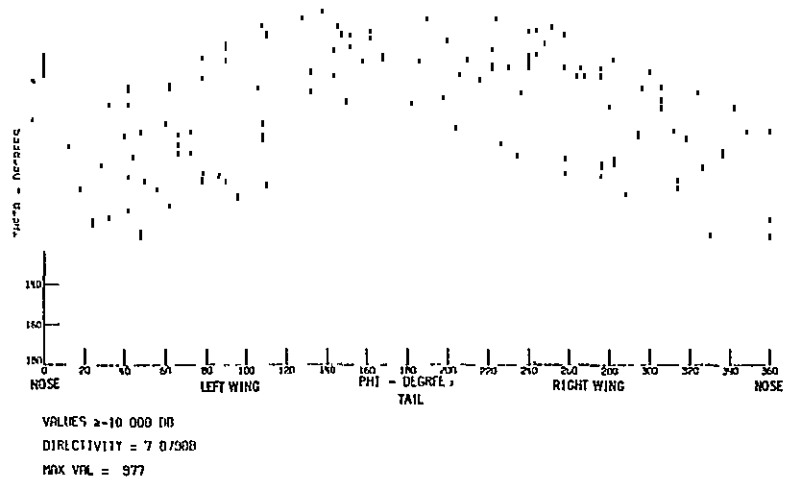

(c) Concluded.

REPRODUCIBILITY OF THE  
 Figure A-1.- Continued. ORIGINAL PAGE IS POOR



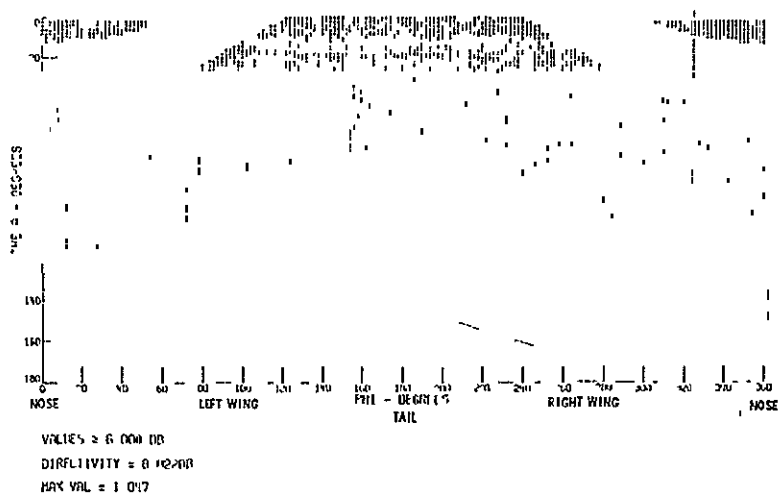
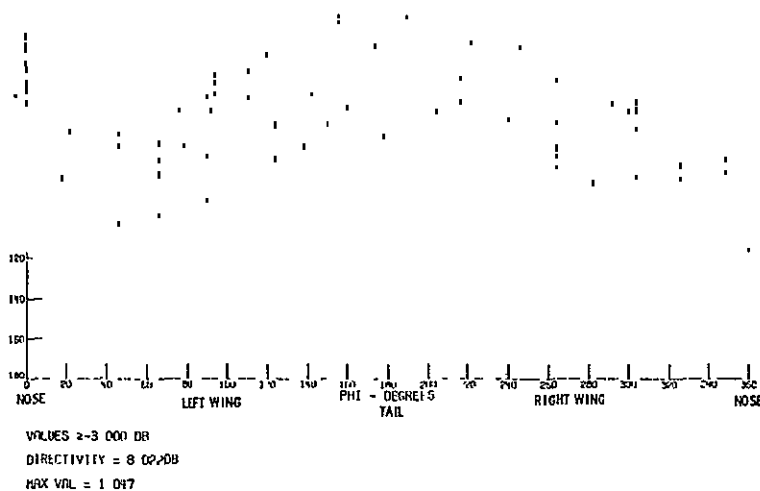
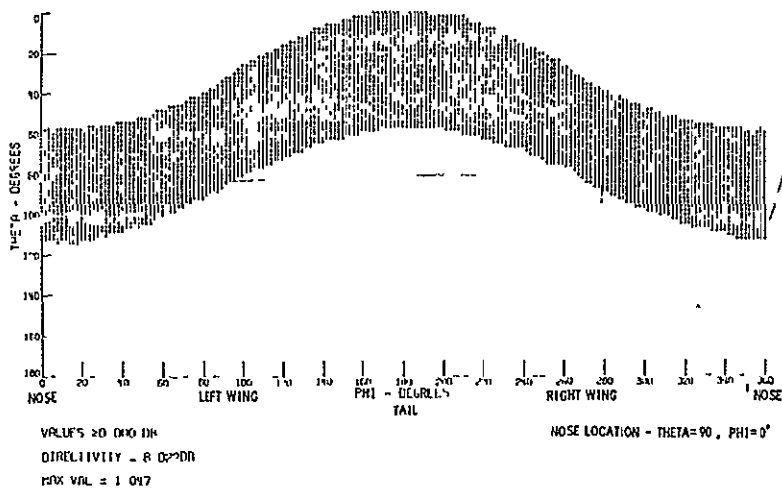

(d) Horizontally polarized coaxial fed slot antenna at station 220 with landing gear.

Figure A-1.- Continued.

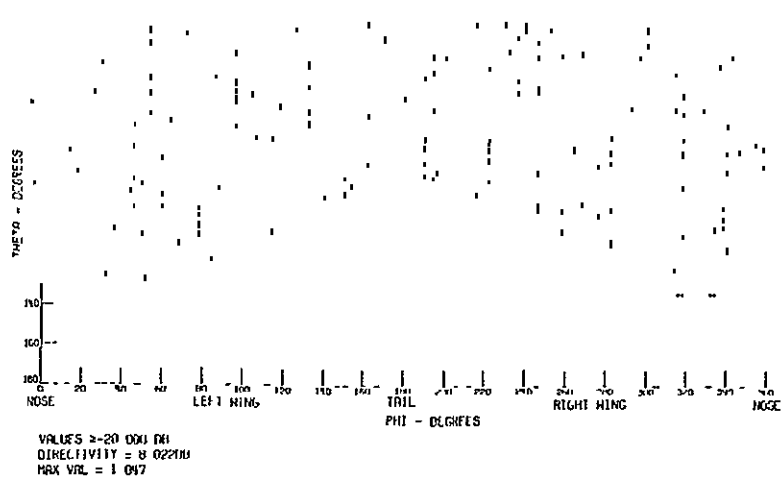
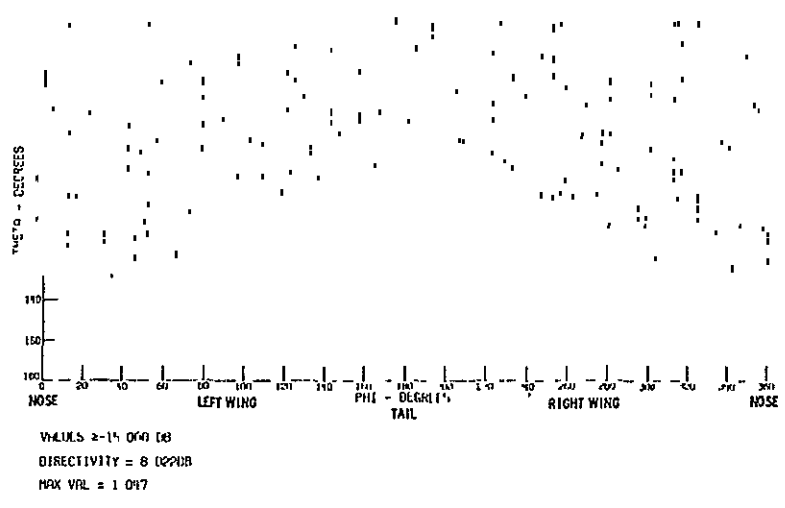
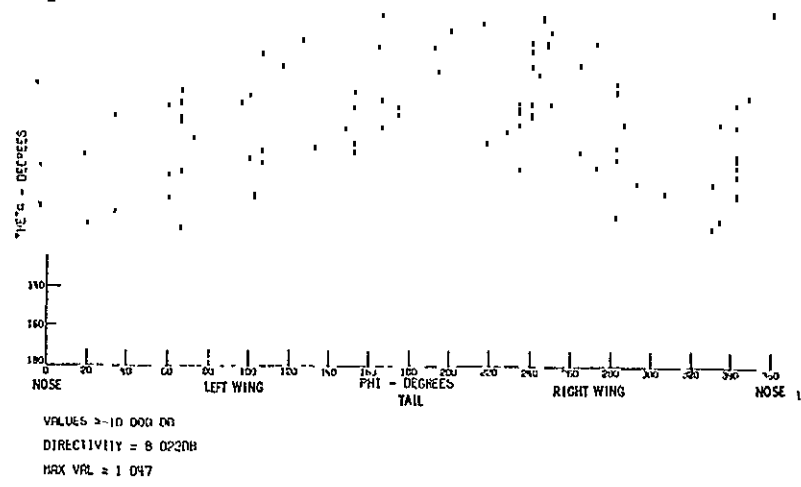

(d) Concluded.

Figure A-1.- Continued.

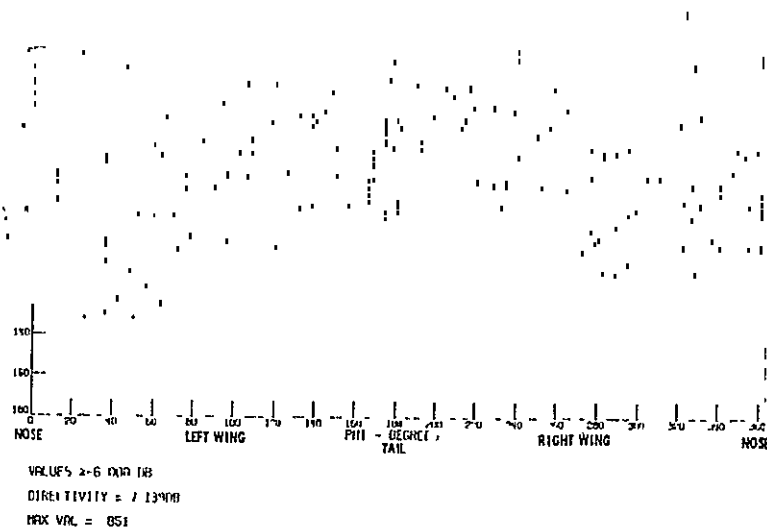
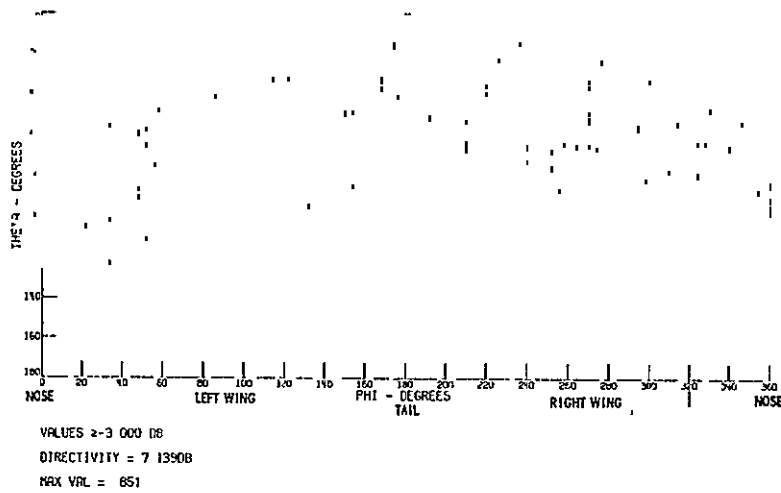
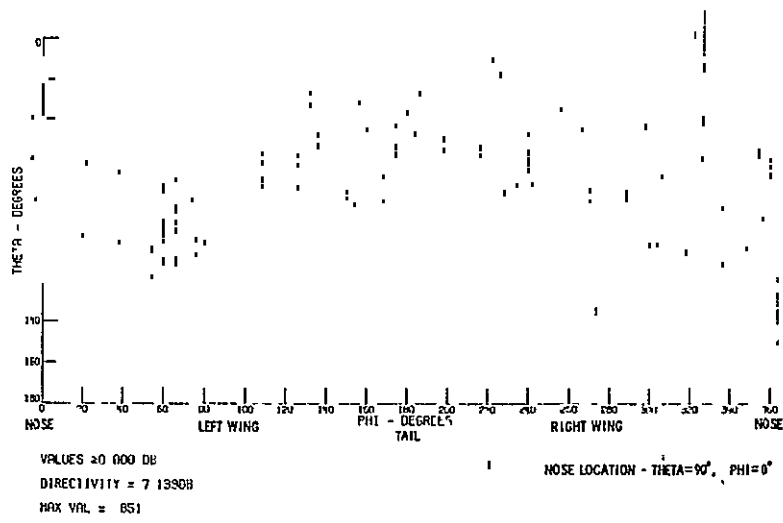

(e) Monopole at station 250 on top fuselage (off centerline).

Figure A-1.- Continued.



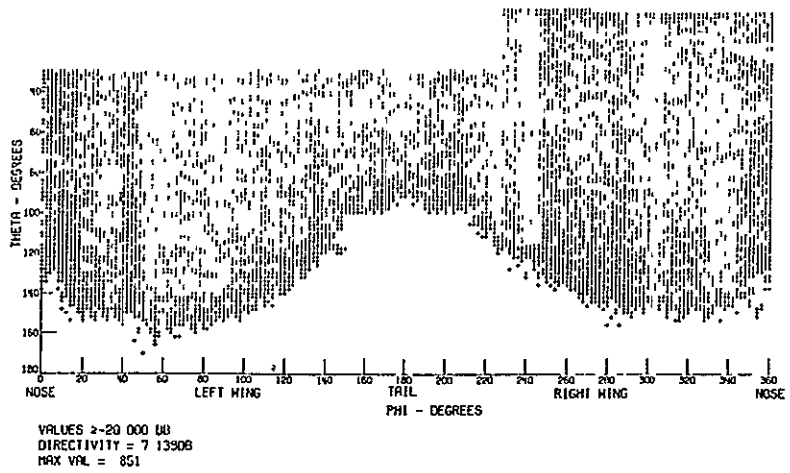
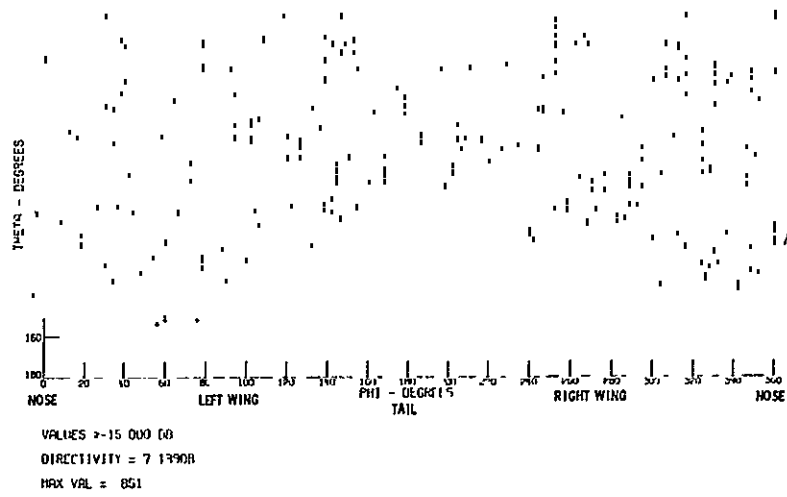
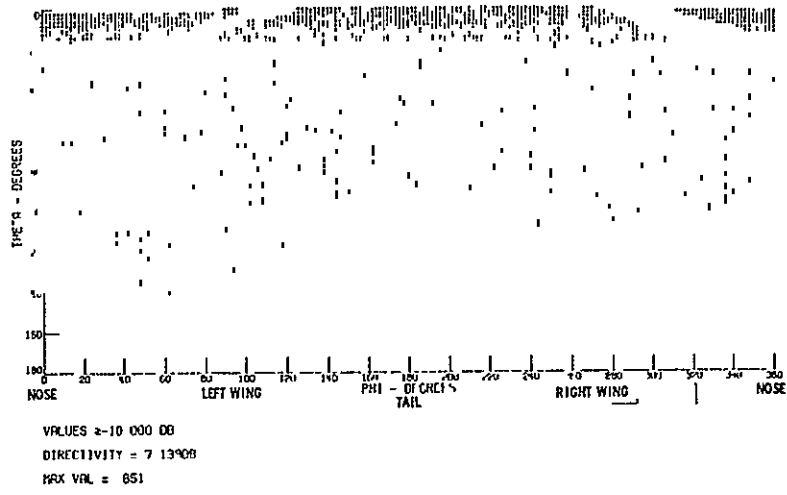

(e) Concluded.

Figure A-1.- Continued.

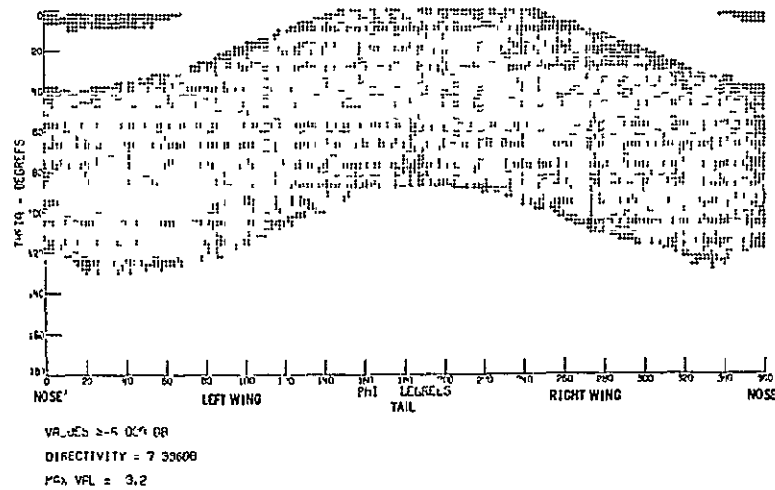
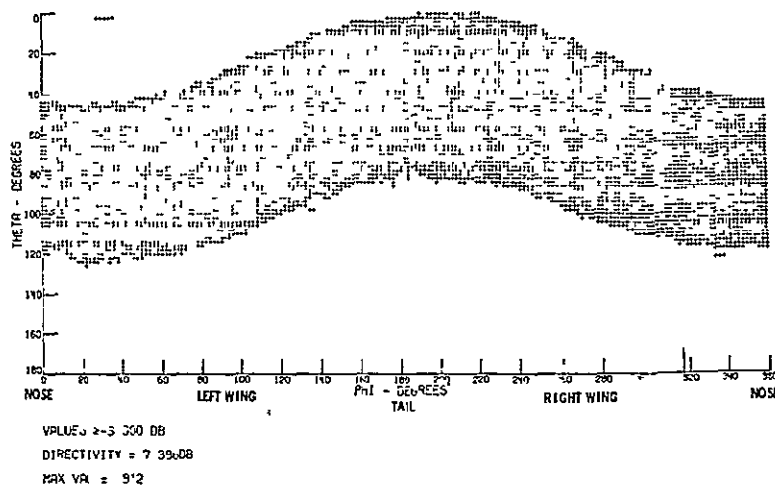
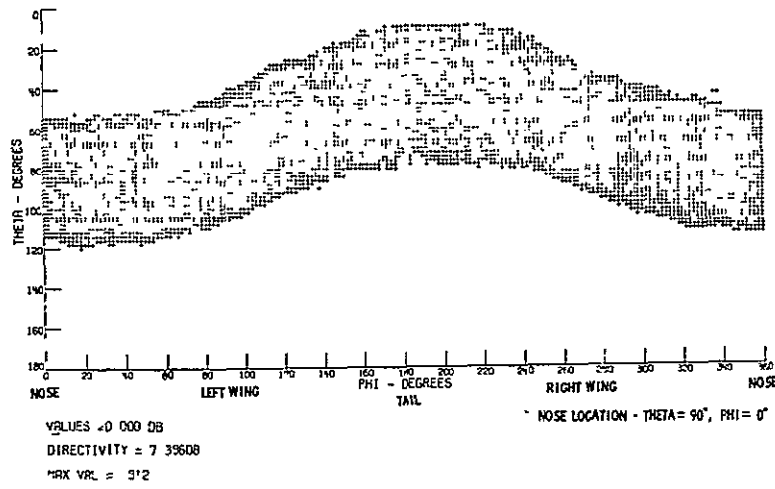

(f) Monopole at station 250 on top fuselage  
(off centerline) with landing gear.

Figure A-1.-- Continued.

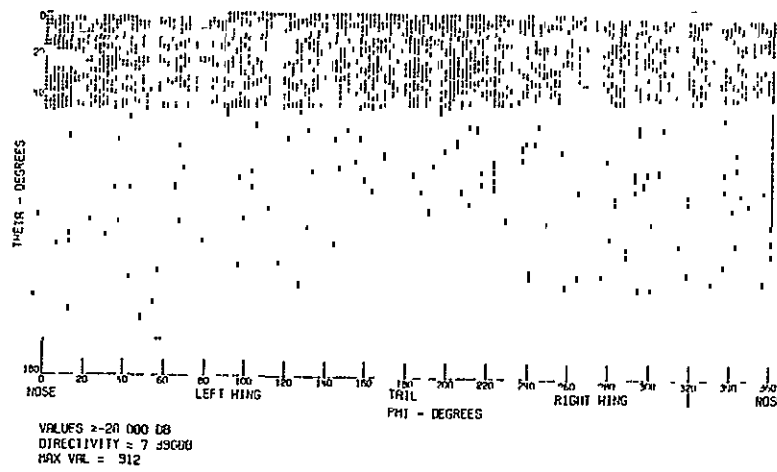
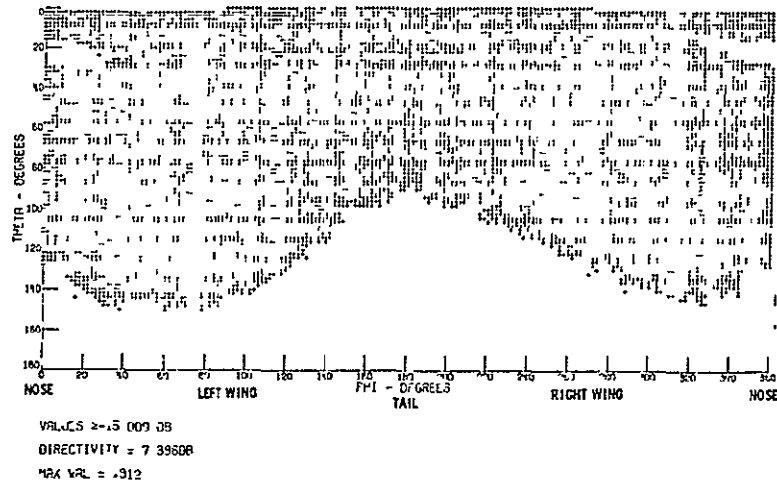
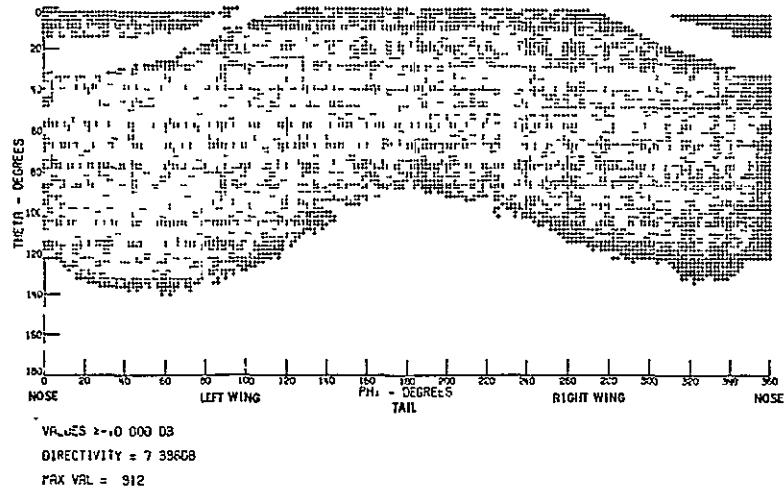

(f) Concluded.

REPRODUCIBILITY OF THE ORIGINAL PAGE IS POOR

Figure A-1.- Continued.



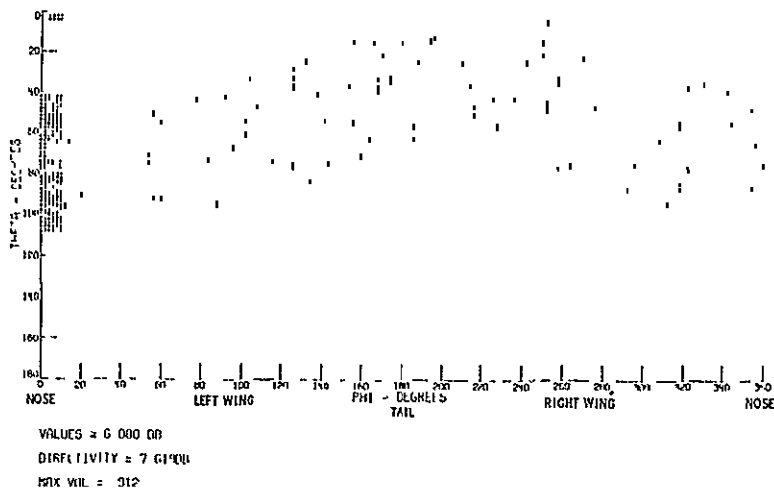
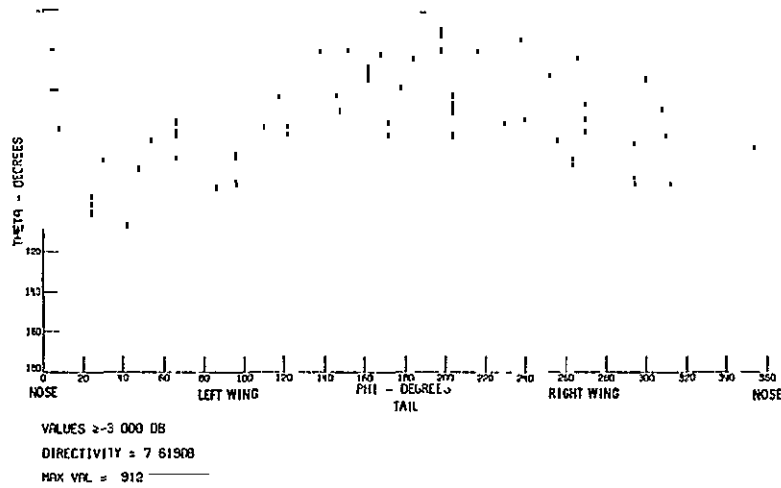
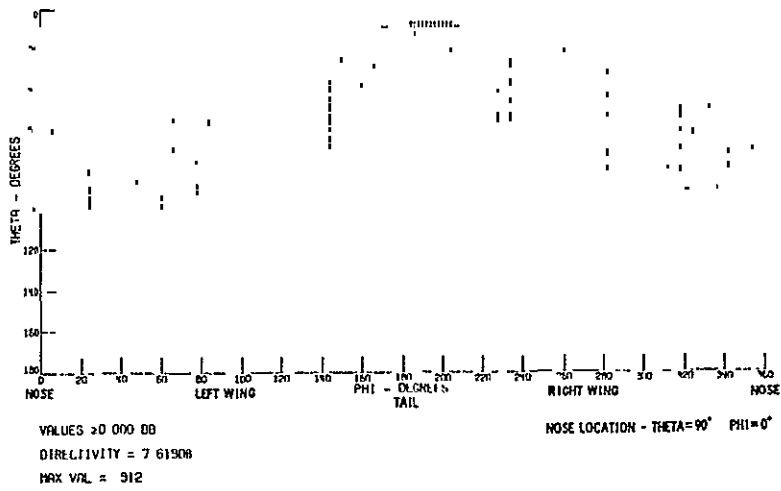

(g) Horizontally polarized slot antenna at station 250 on top fuselage (off centerline) with landing gear.

Figure A-1.- Continued.

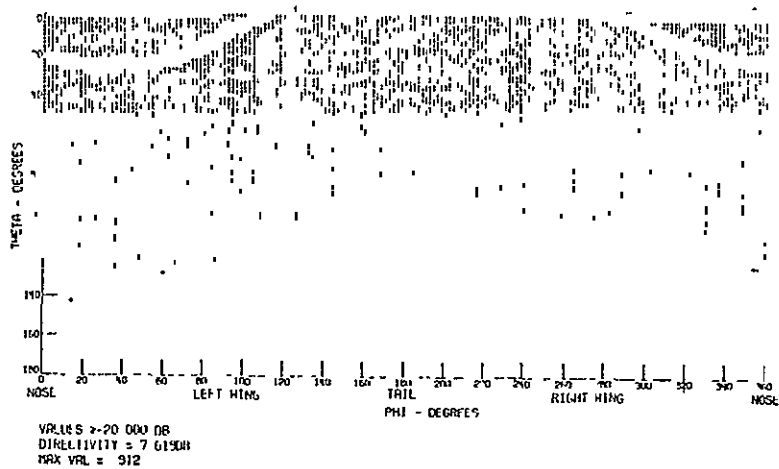
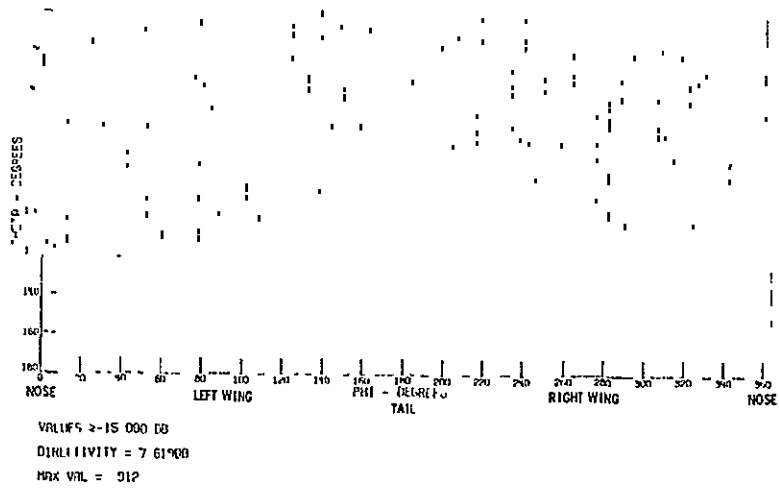
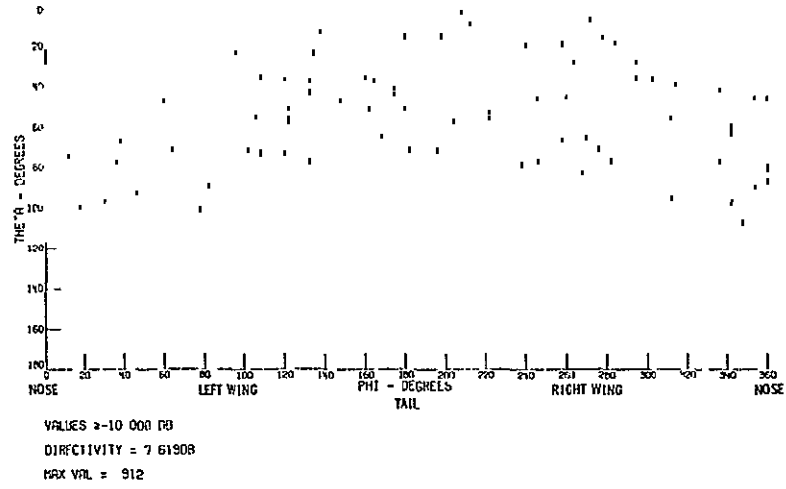

(g) Concluded.

Figure A-1.- Continued.

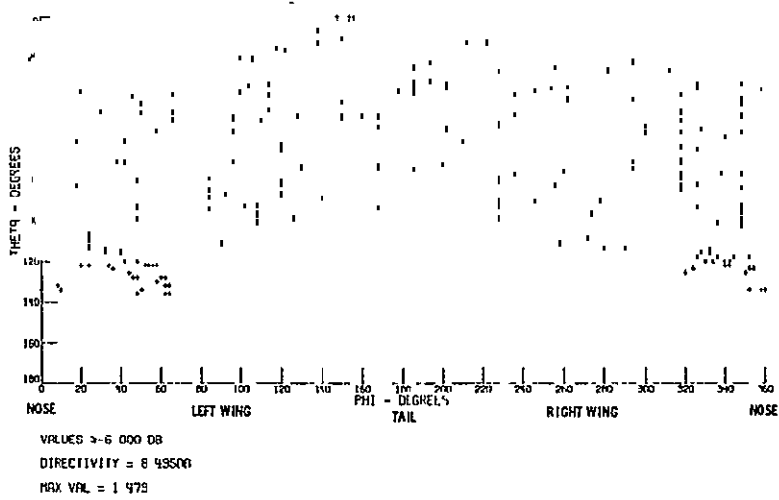
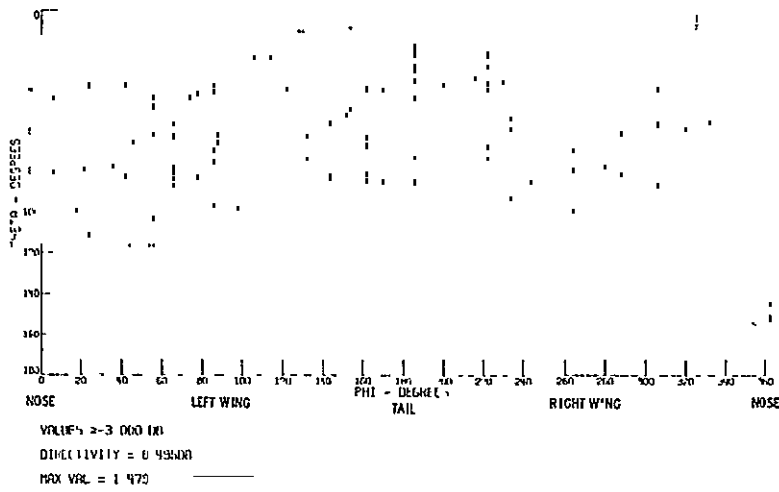
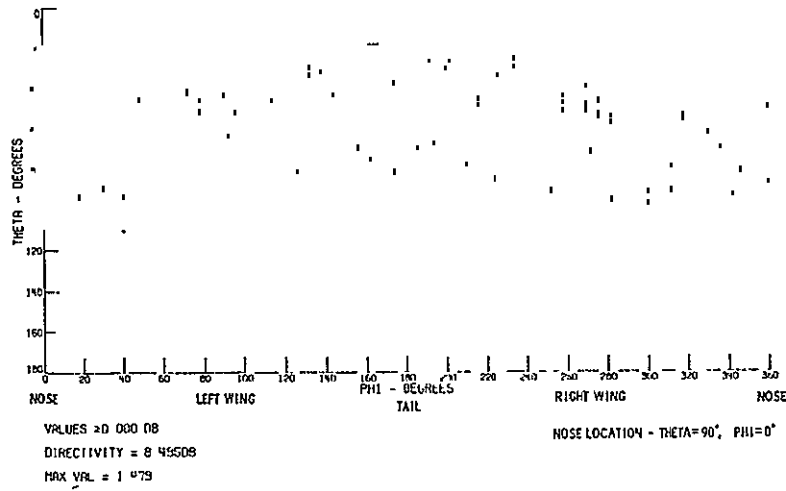

(h) Monopole at station 305 on top fuselage.

Figure A-1.- Continued.



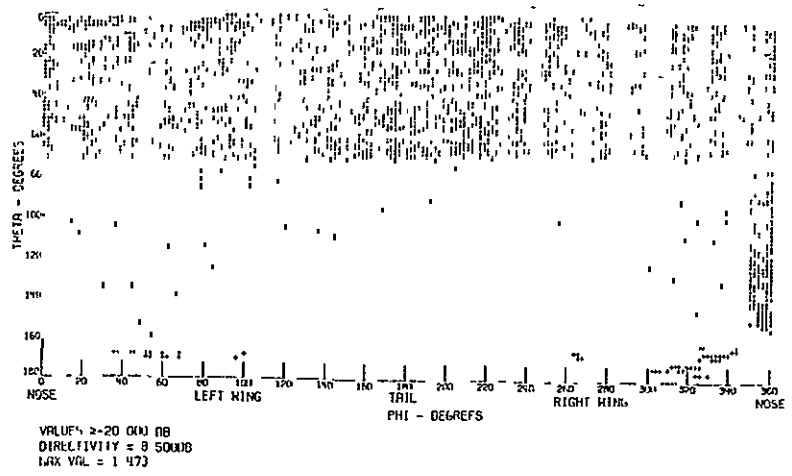
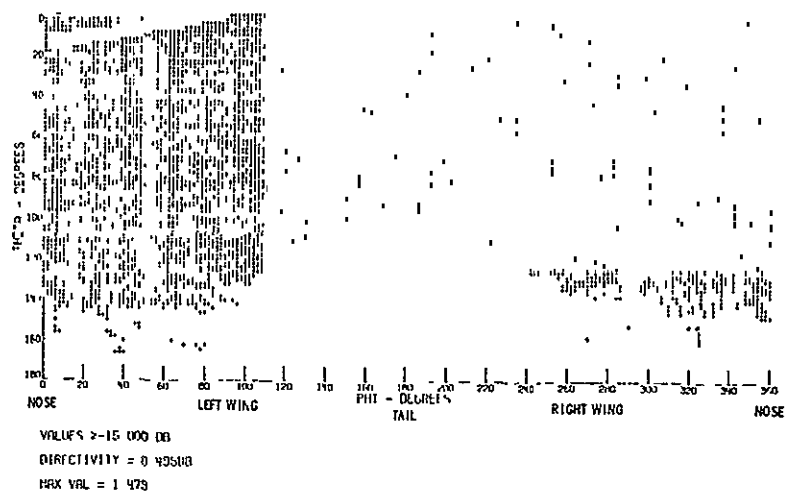
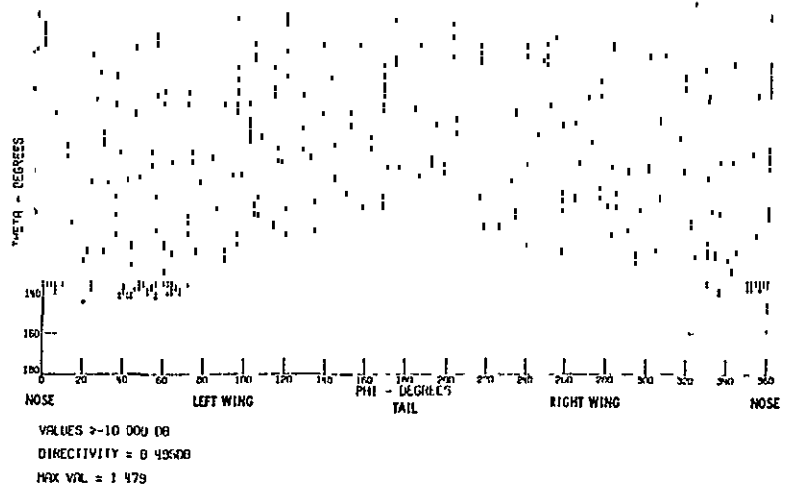

(h) Concluded.

Figure A-1.- Continued.

REPRODUCIBILITY OF THE ORIGINAL PAGE IS POOR

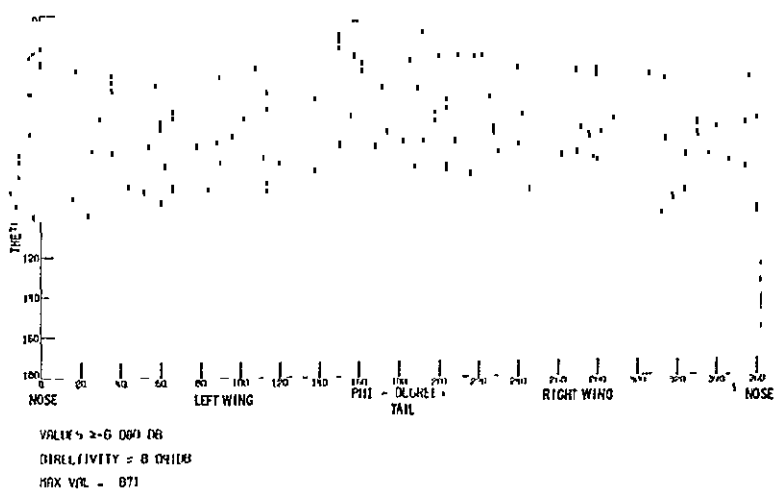
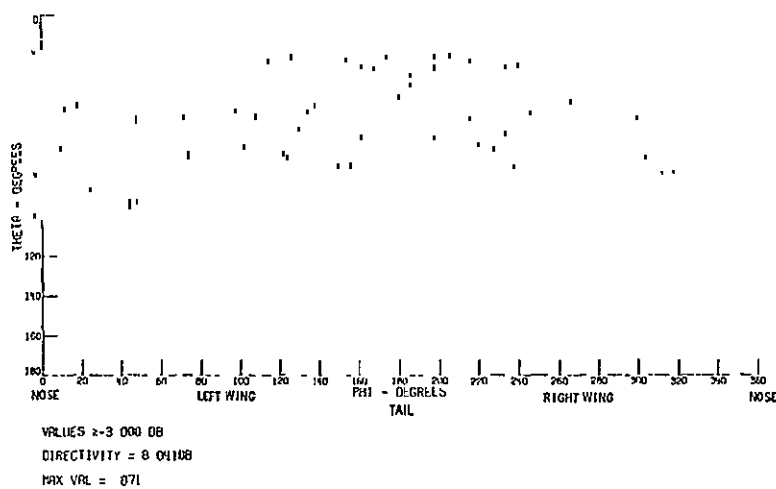
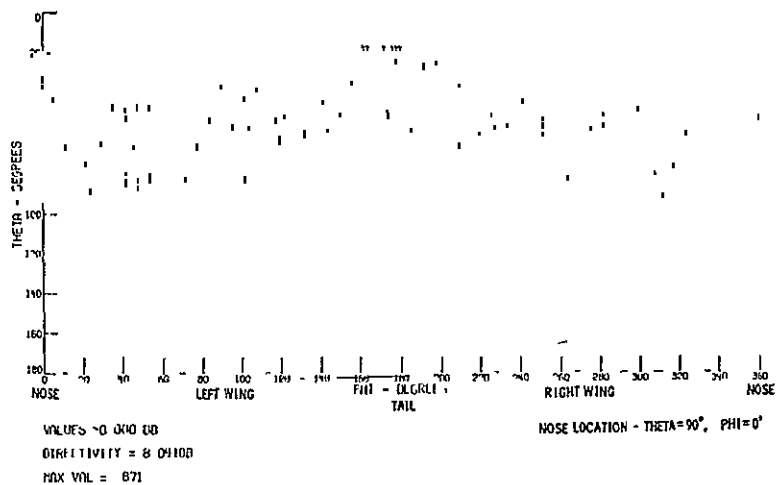

(i) Horizontally polarized coaxial fed slot antenna at station 305 on top fuselage with landing gear.

Figure A-1.- Continued.

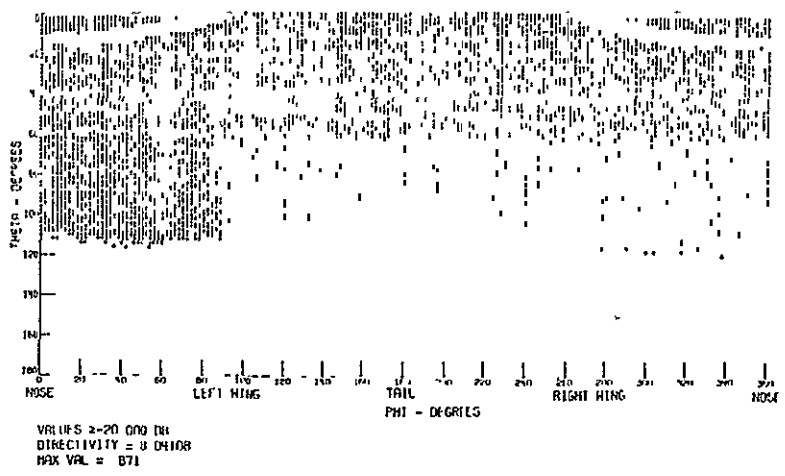
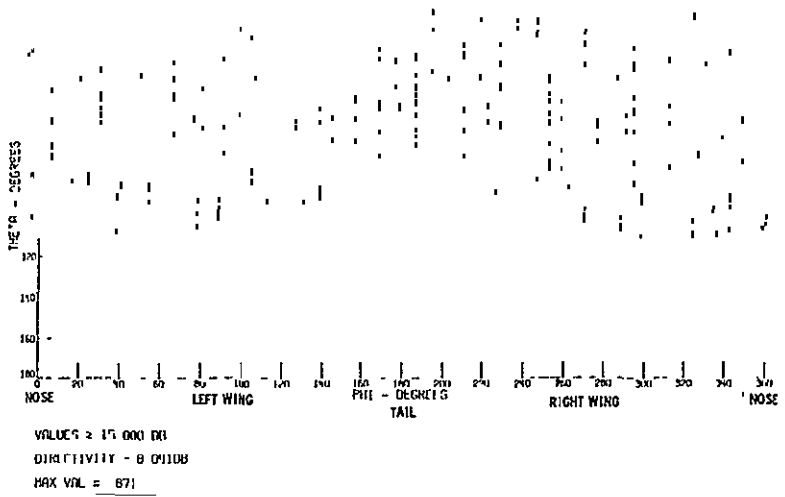
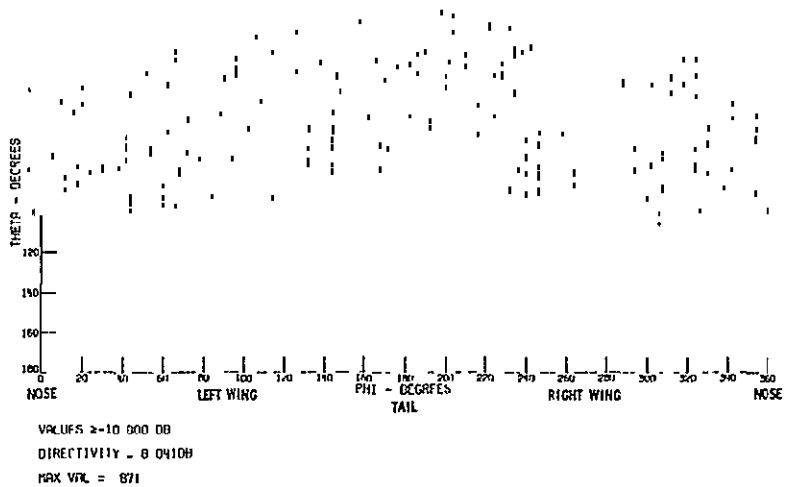

(i) Concluded.

REPRODUCIBILITY OF THE ORIGINAL PAGE IS POOR

Figure A-1.- Continued.



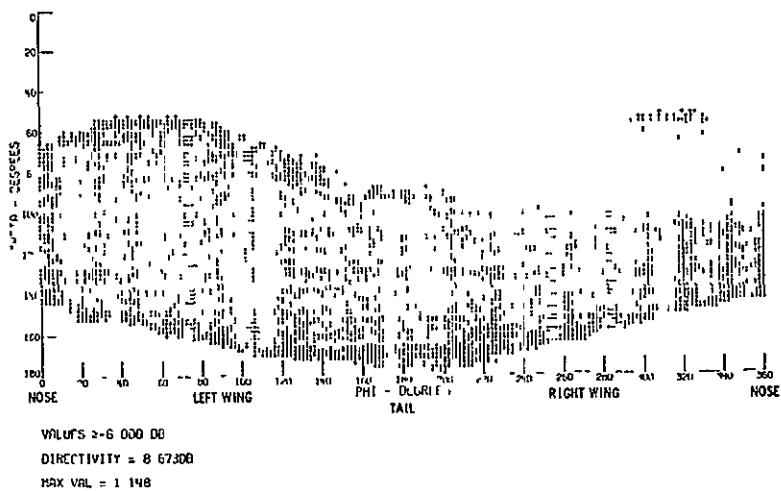
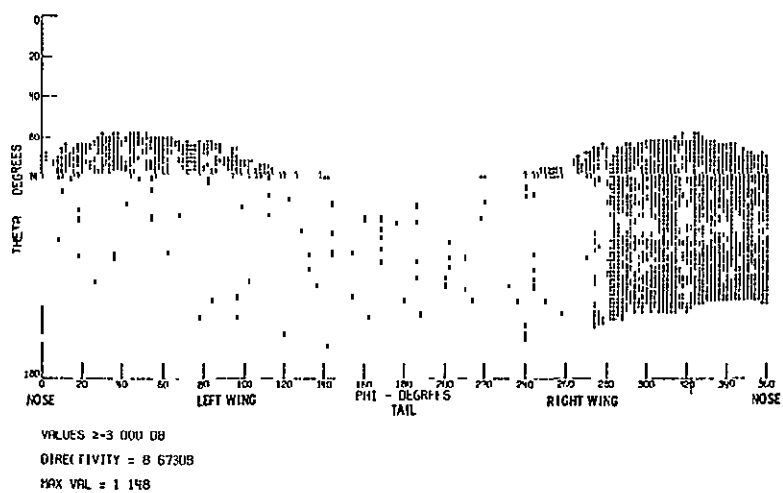
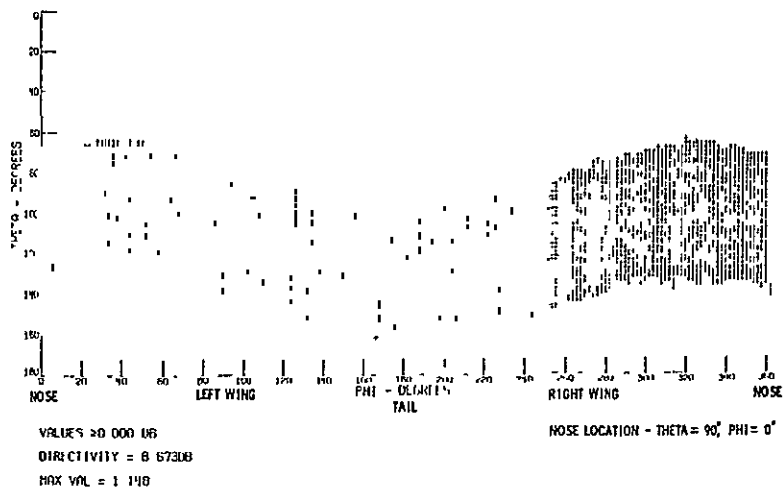

(j) Monopole at station 222 on bottom fuselage.

Figure A-1.- Continued.

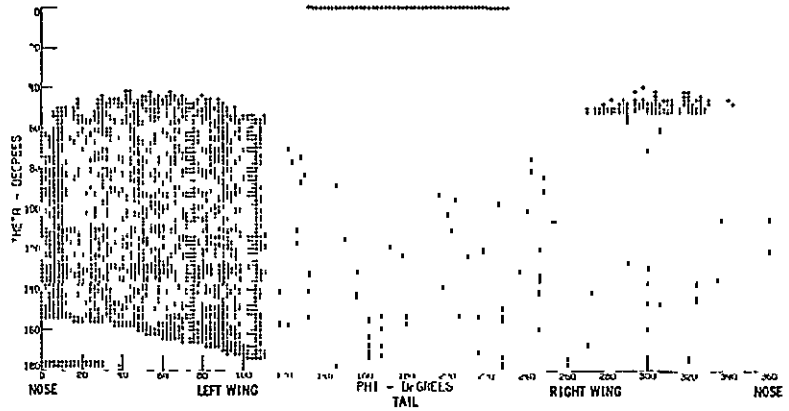

VALUES > 10 000 DB  
 DIRECTIVITY = 8 67308  
 MAX VAL = 1 148

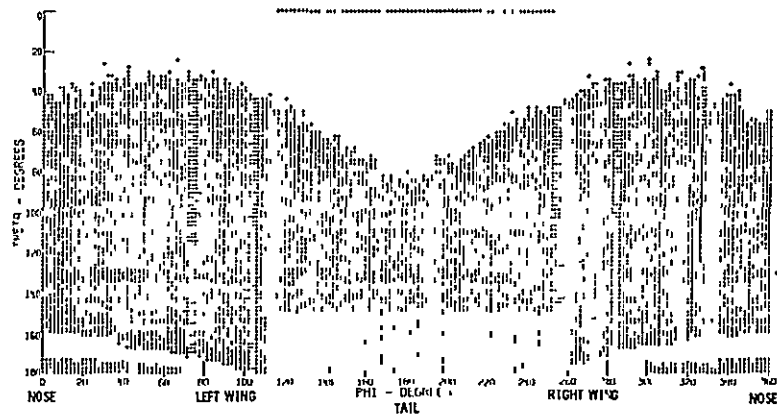

VALUES > 15 000 DB  
 DIRECTIVITY = 8 67308  
 MAX VAL = 1 148

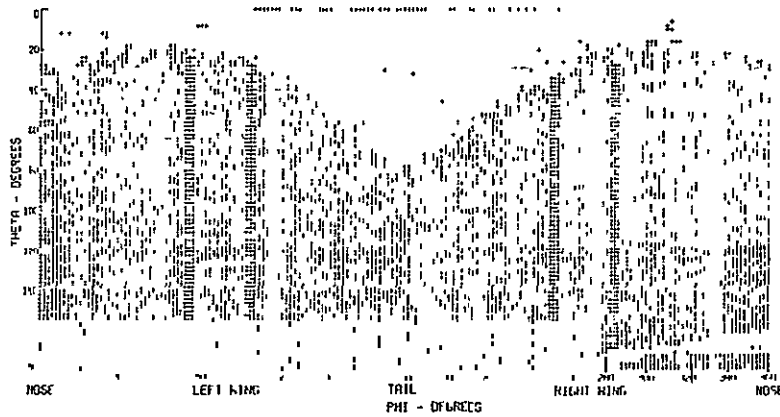

VALUES > 20 000 DB  
 DIRECTIVITY = 8 67300  
 MAX VAL = 1 148

(j) Concluded.

Figure A-1.- Continued.

*C-2*

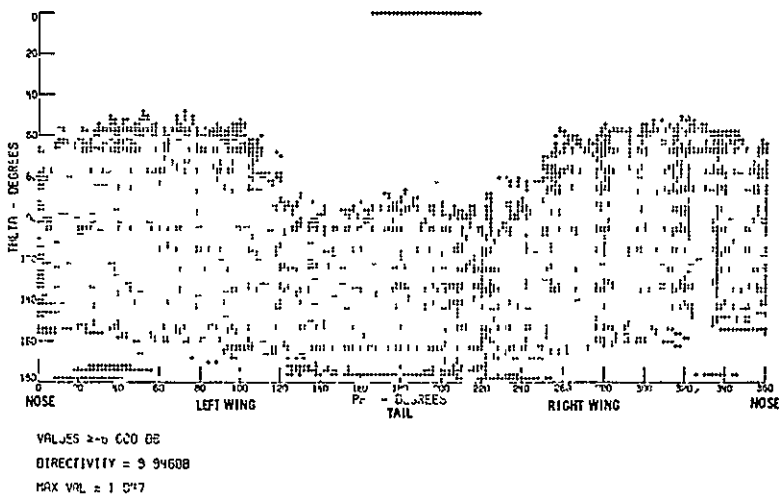
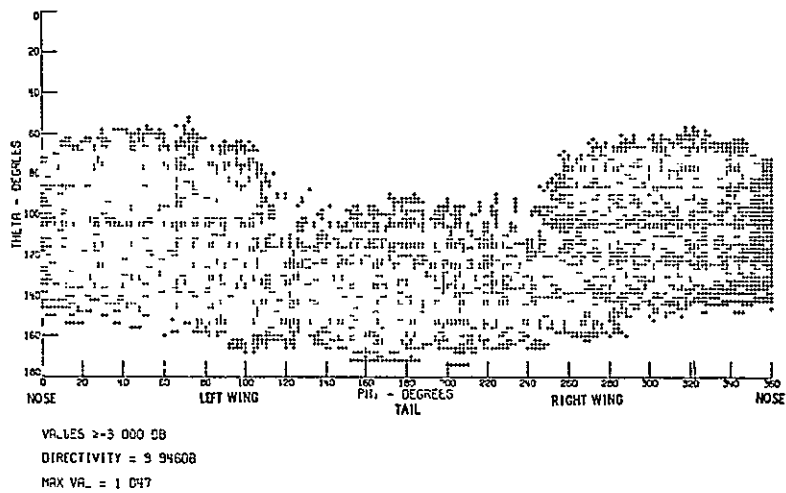
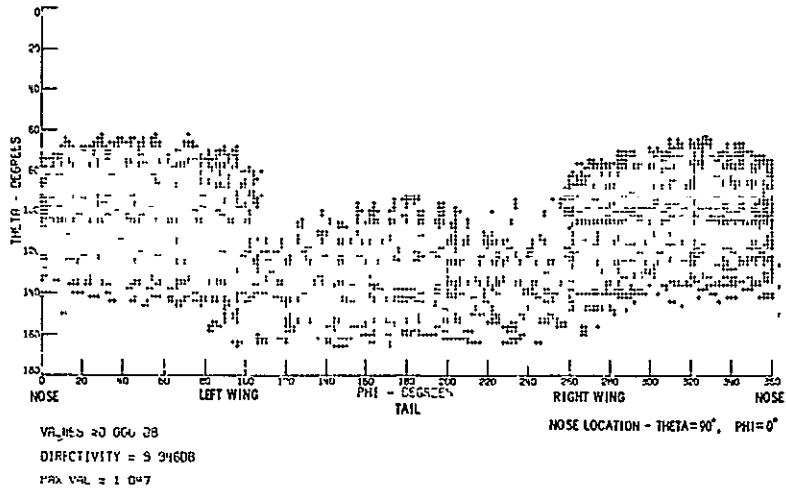

(k) Monopole at station 222 on bottom fuselage with landing gear.

Figure A-1.- Continued.

REPRODUCIBILITY OF THE ORIGINAL PAGE IS POOR

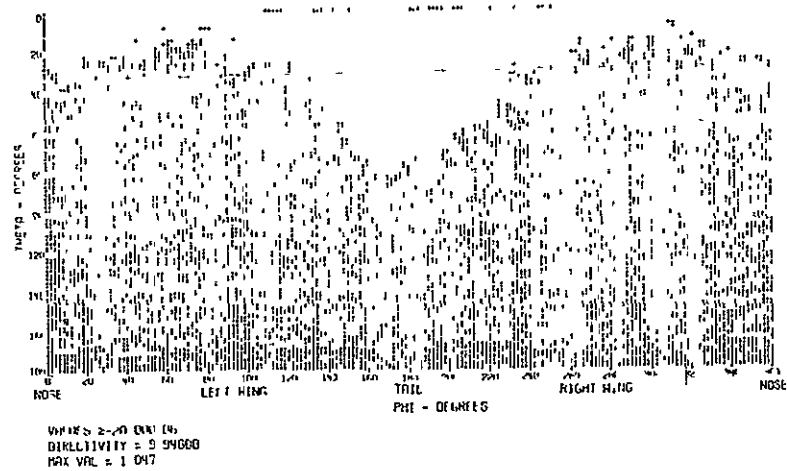
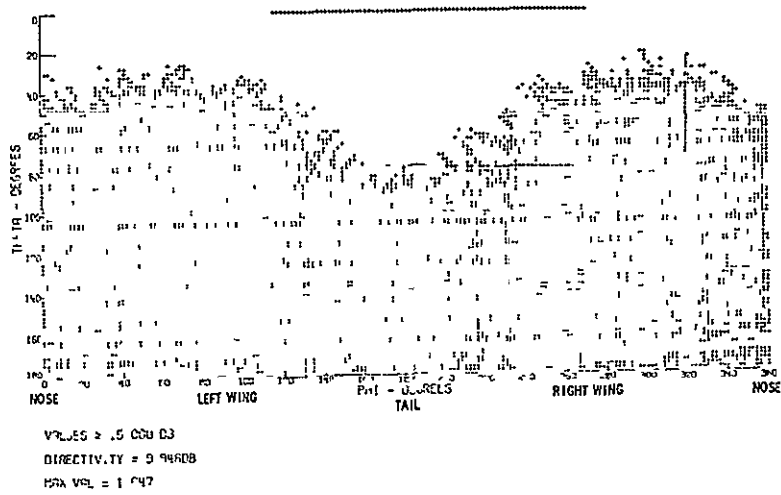
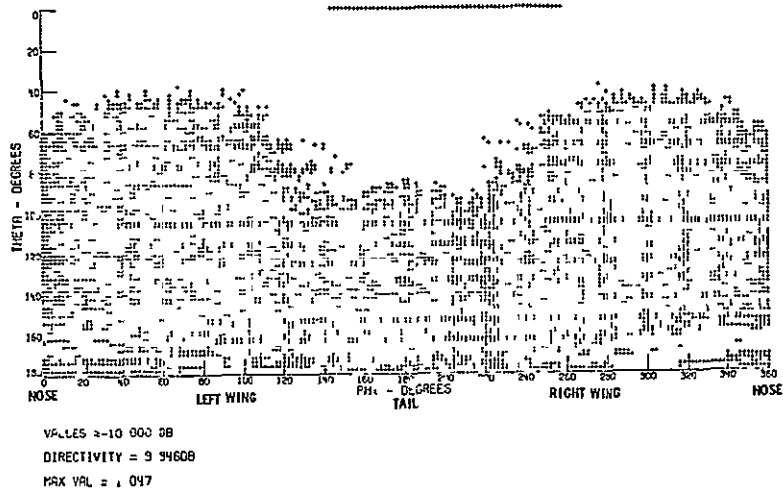

(k) Concluded.

Figure A-1.- Continued.



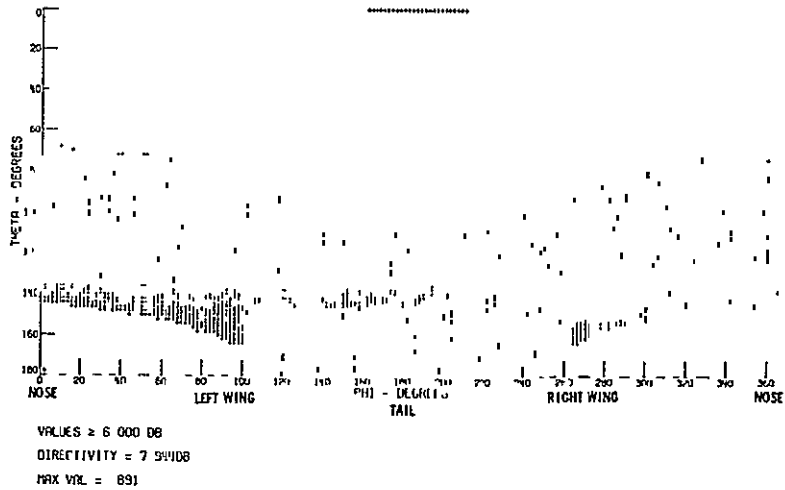
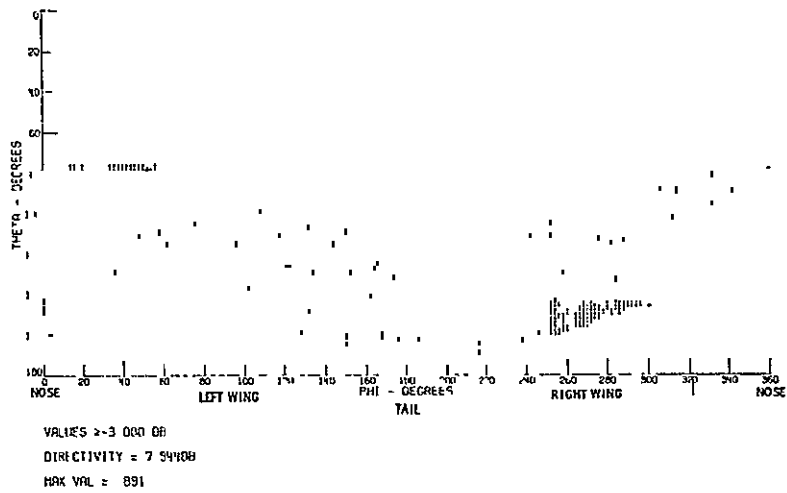
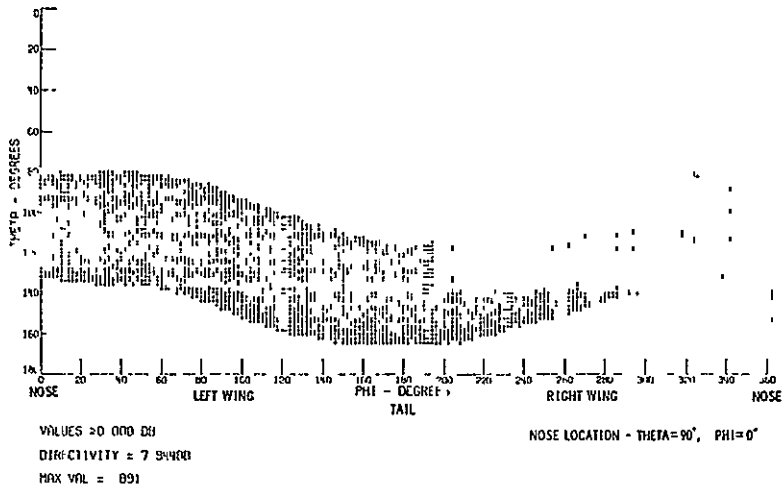

(1) Horizontally polarized coaxial fed slot antenna at station 222 on bottom fuselage.

Figure A-1.- Continued.

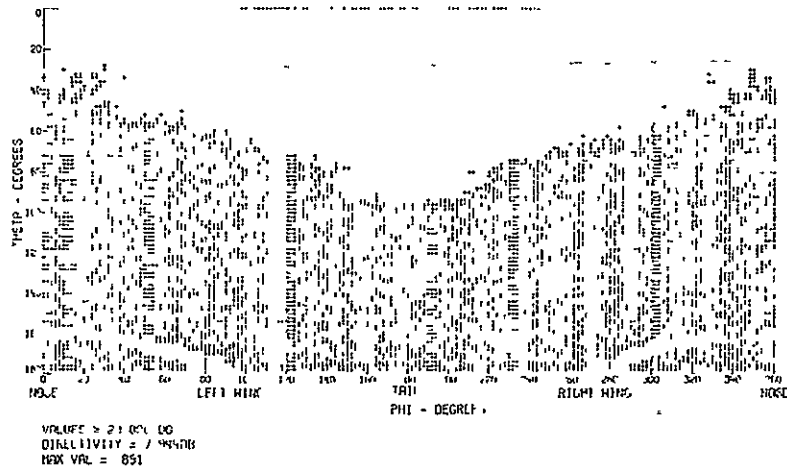
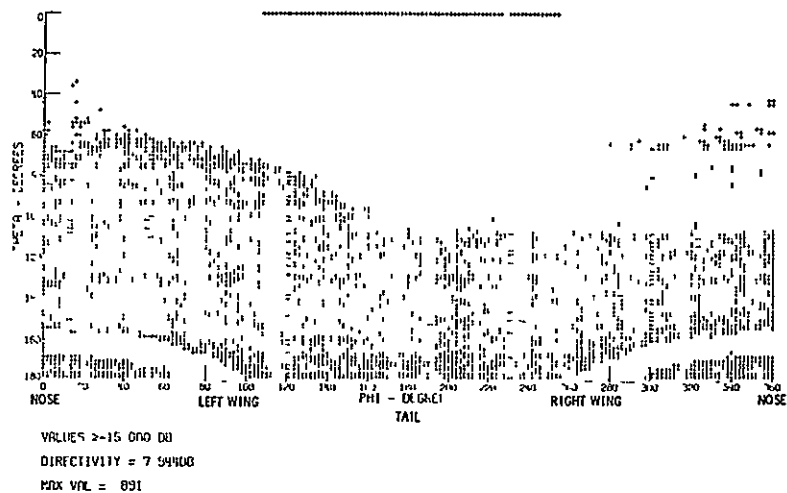
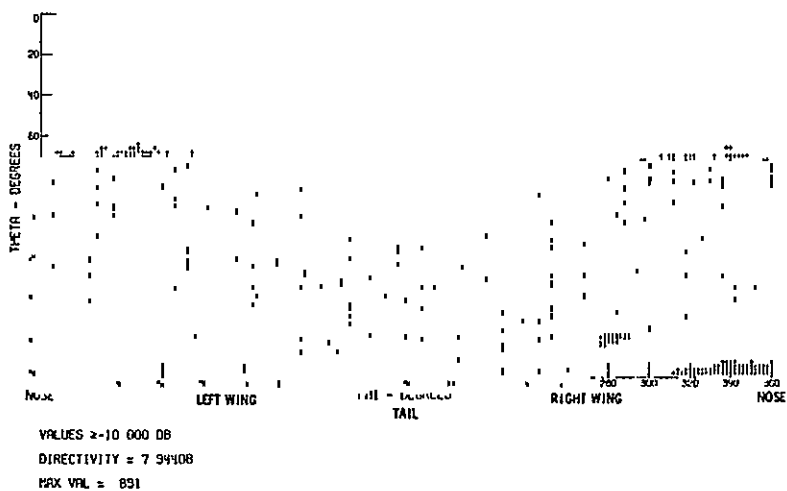

(1) Concluded.

Figure A-1.- Continued.

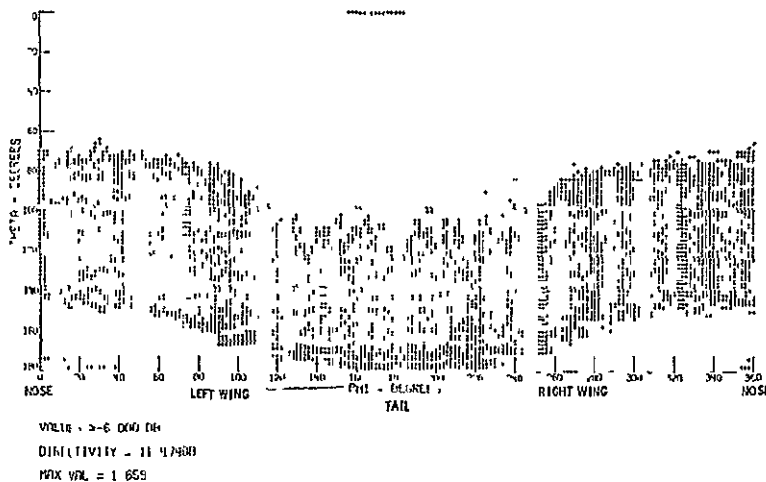
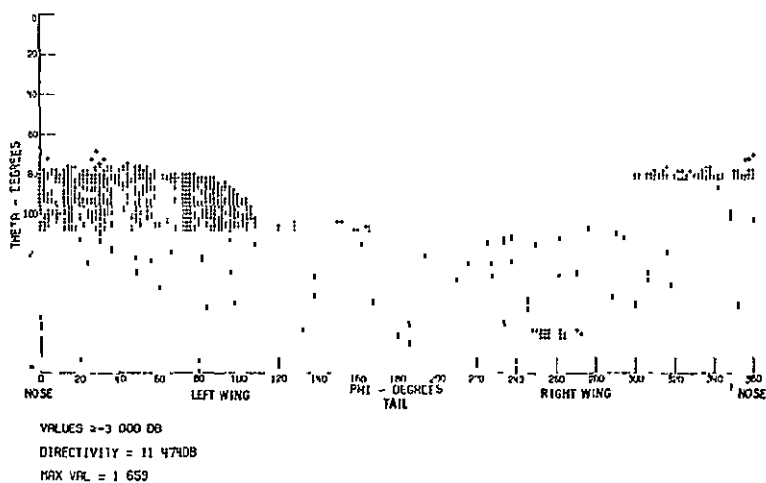
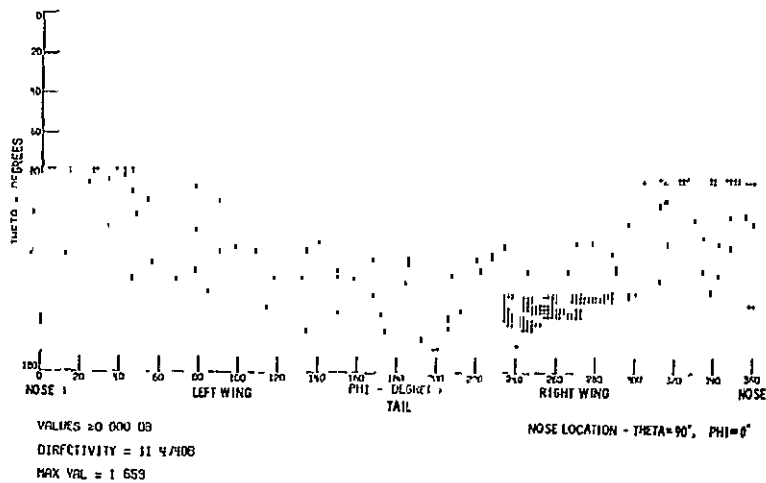

(m) Horizontally polarized coaxial fed slot antenna at station 222 on bottom fuselage with landing gear.

Figure A-1.- Continued.

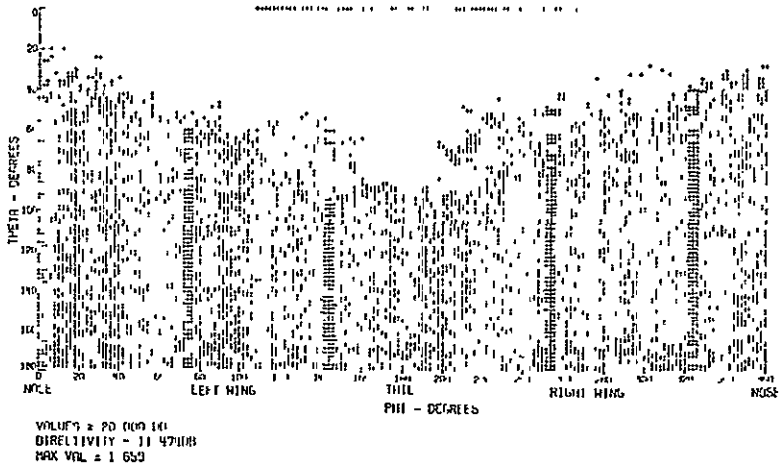
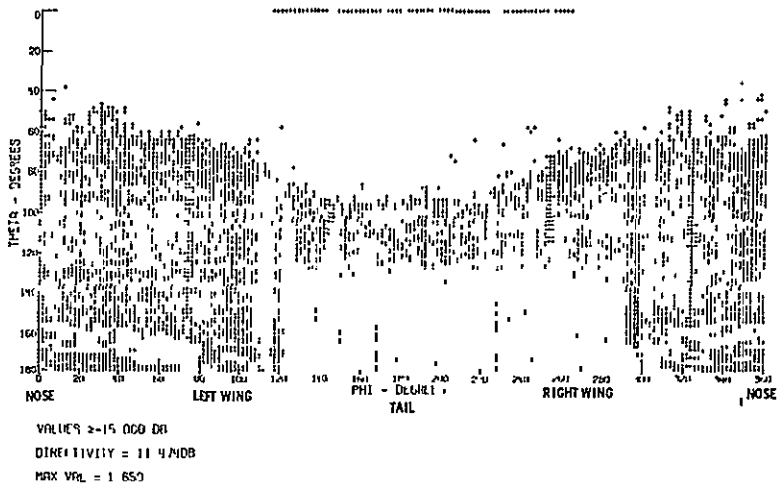
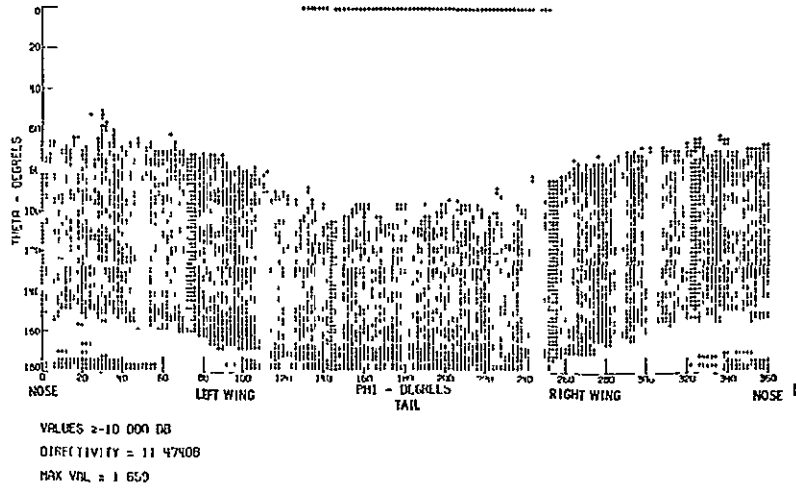

(m) Concluded.

Figure A-1.- Continued.



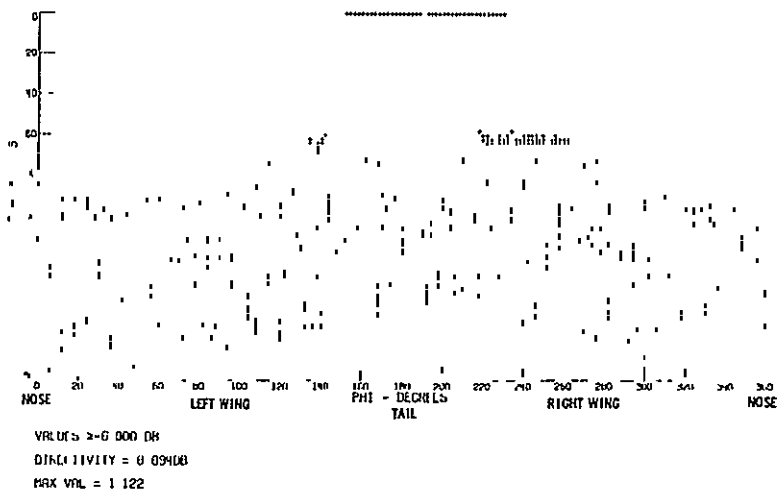
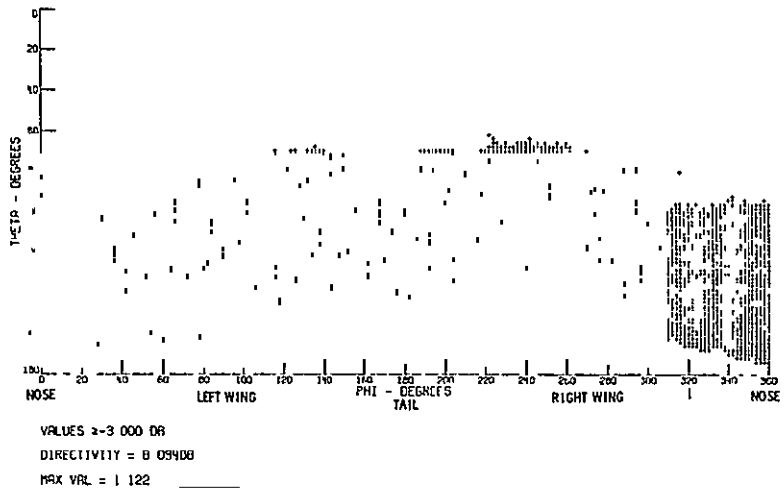
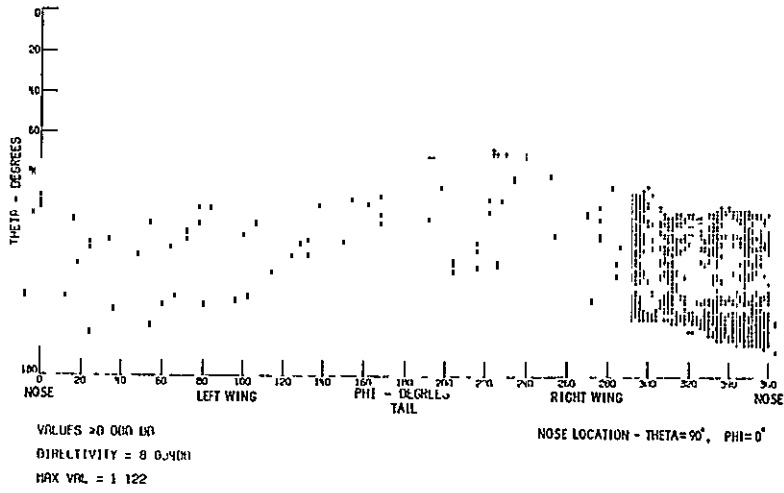

(n) Monopole at station 950 on bottom fuselage.

Figure A-1.- Continued.

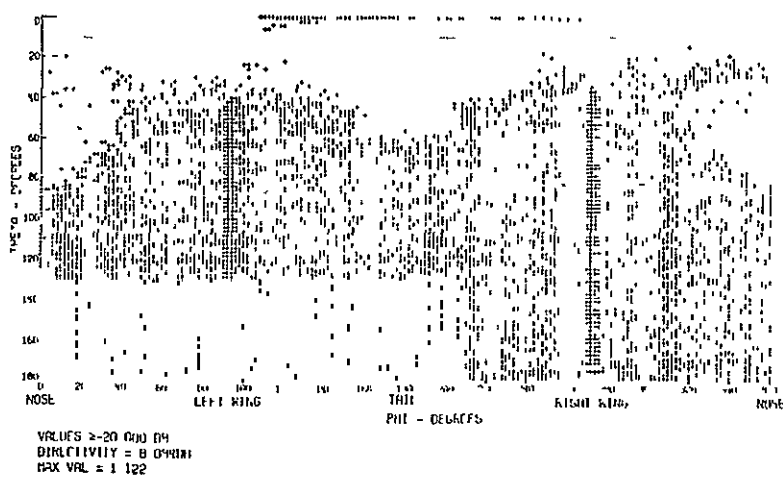
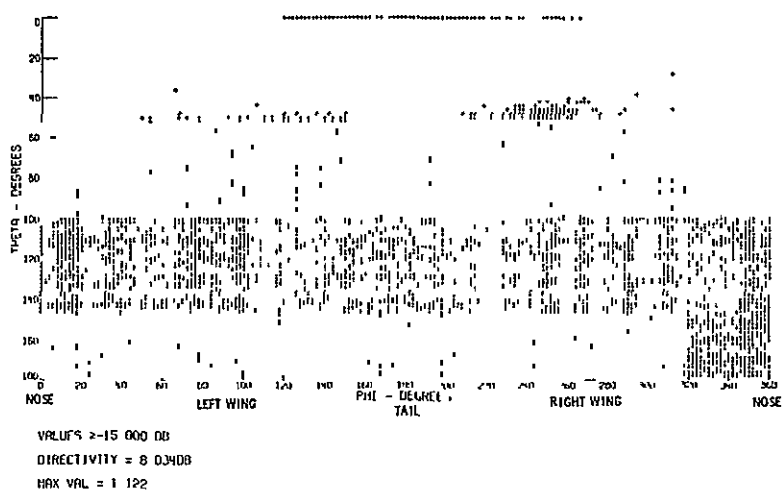
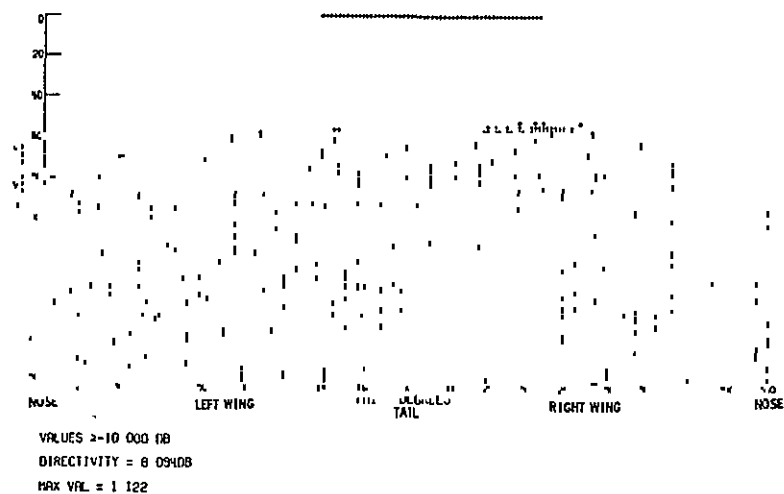

(n) Concluded

**REPRODUCIBILITY OF THE ORIGINAL PAGE IS POOR**

Figure A-1.- Continued.

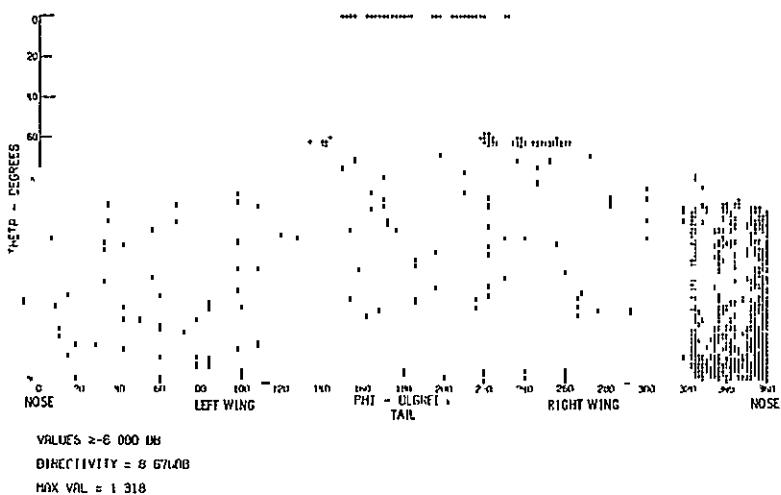
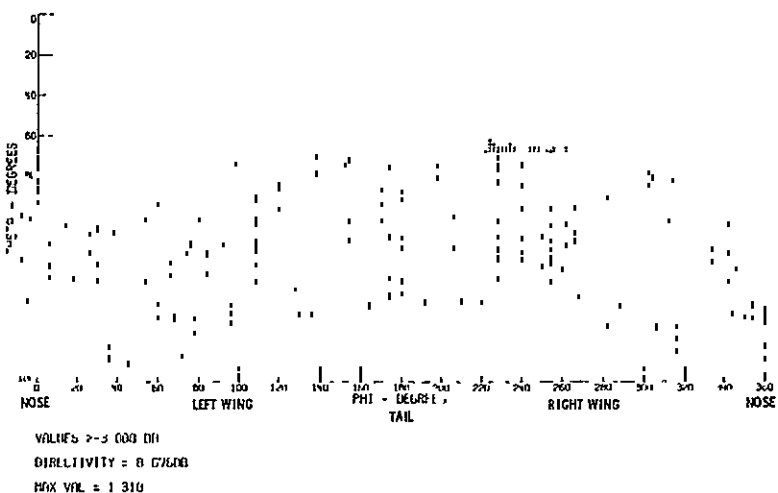
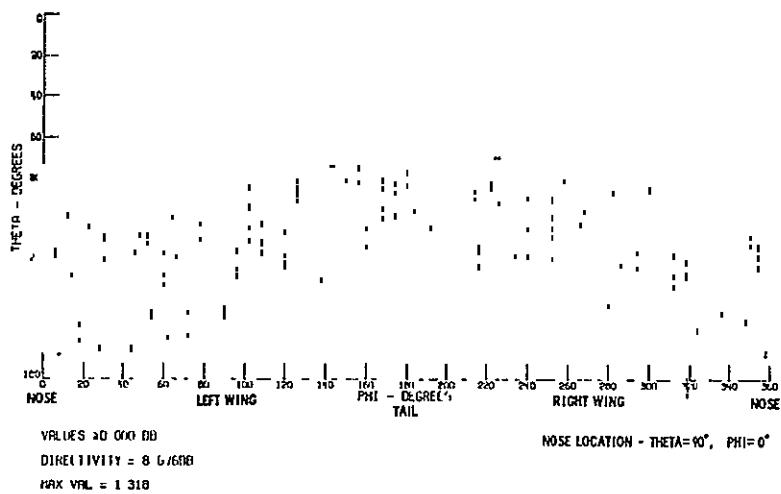

(o) Monopole at station 950 on bottom fuselage with landing gear.

Figure A-1.- Continued.

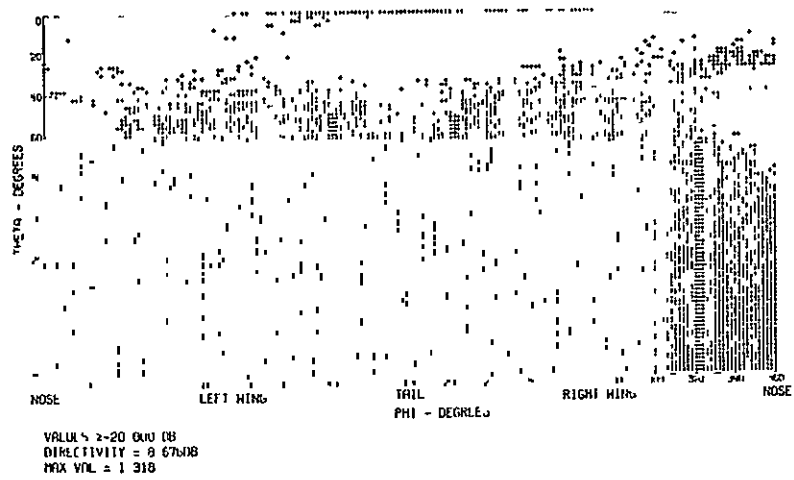
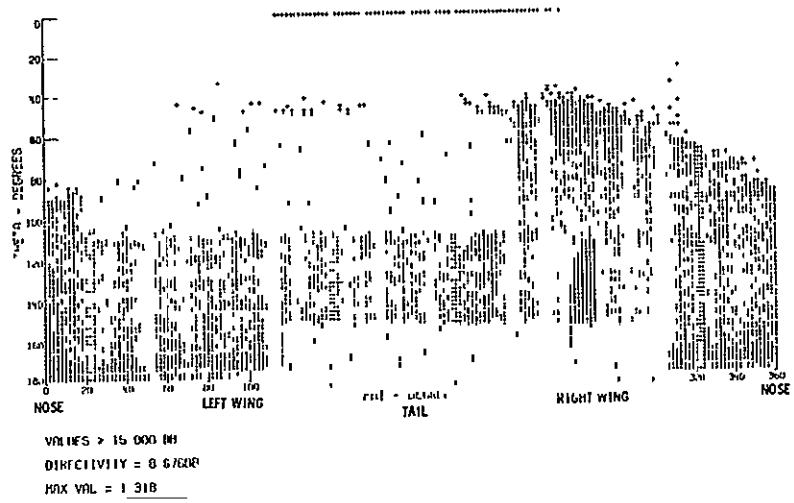
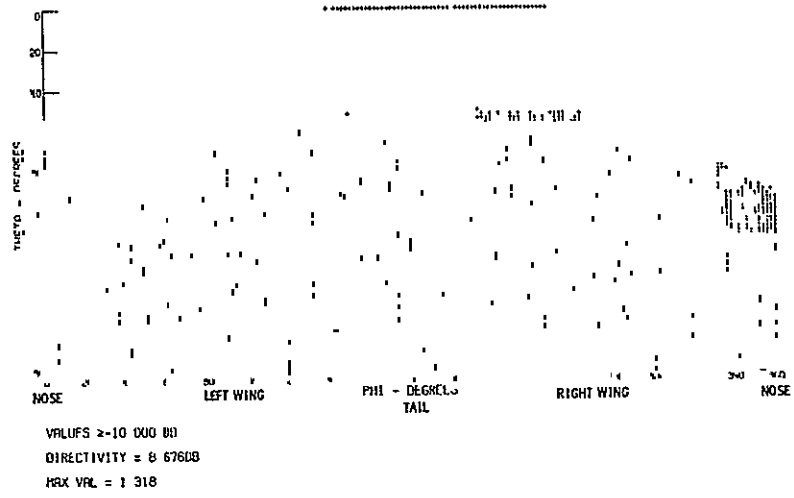

(o) Concluded.

Figure A-1.- Continued.



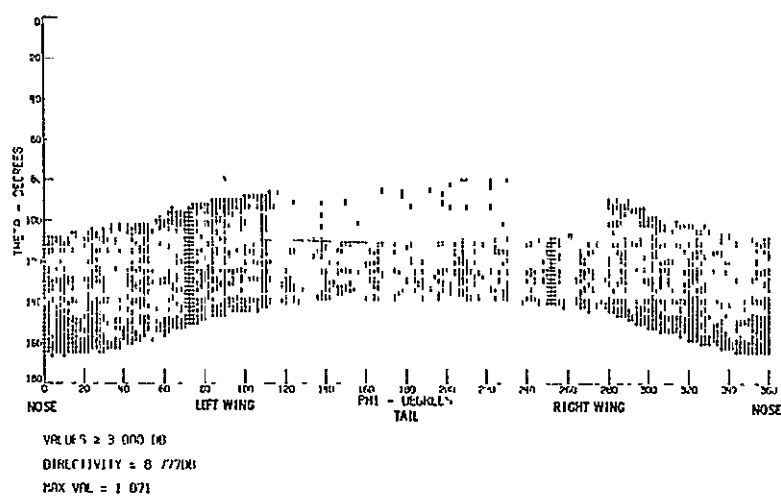
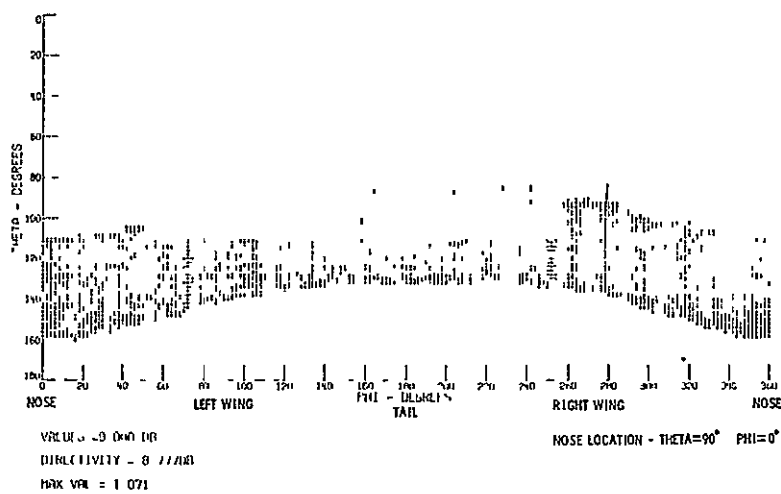

(p) Horizontally polarized coaxial fed slot antenna at station 950 on bottom fuselage.

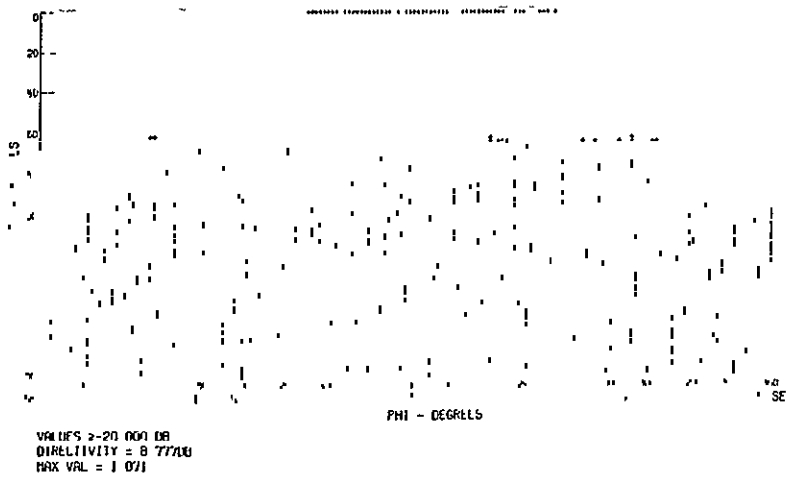
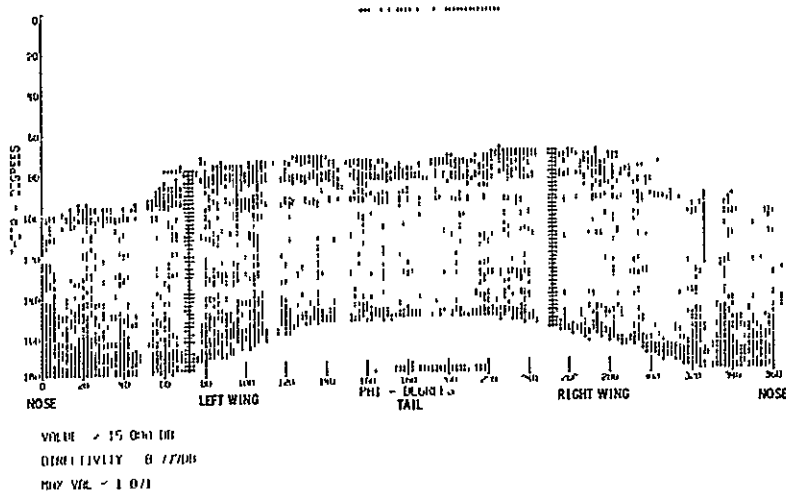
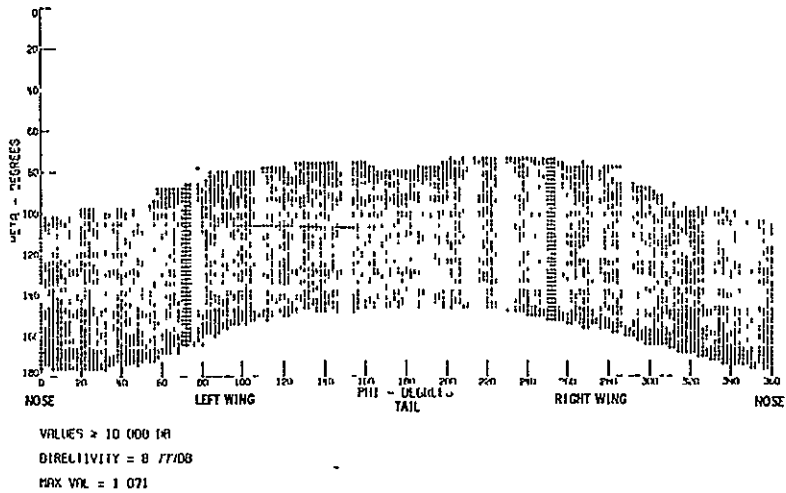

(p) Concluded.

REPRODUCIBILITY OF THE ORIGINAL PAGE IS POOR

Figure A-1.- Continued.

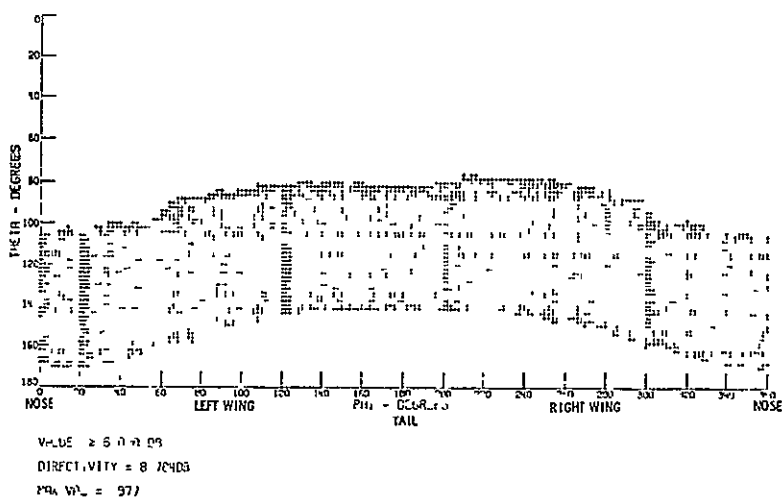
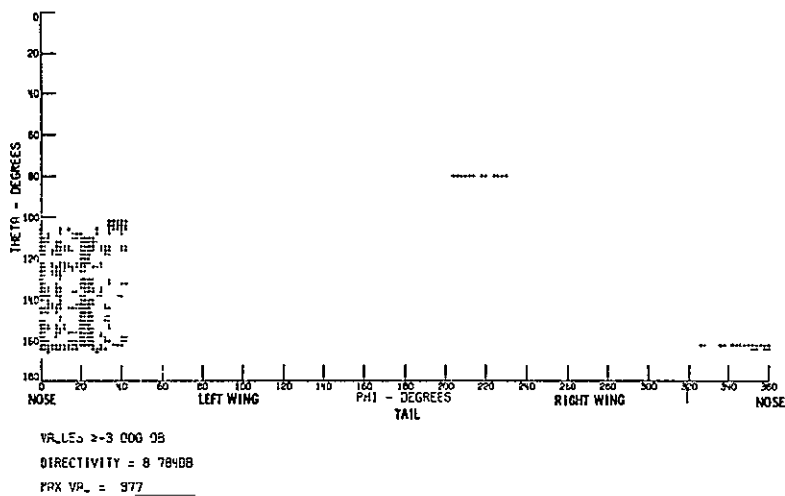
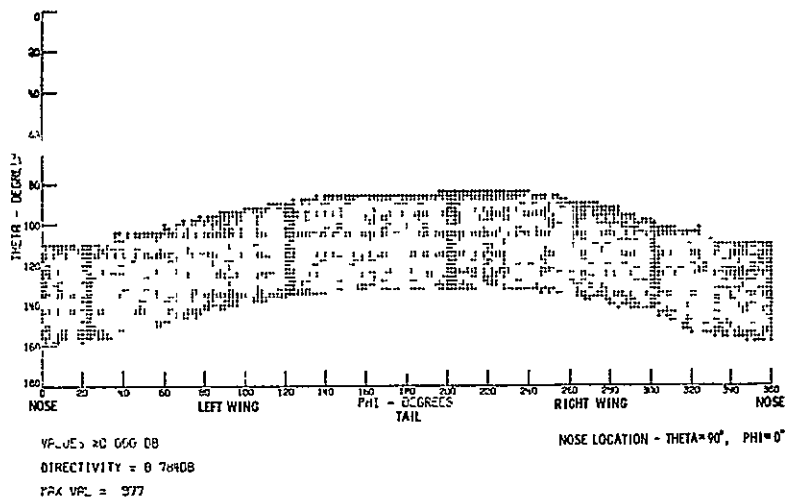

(q) Horizontally polarized coaxial fed slot antenna at station 950 on bottom fuselage with landing gear.

Figure A-1.- Continued.

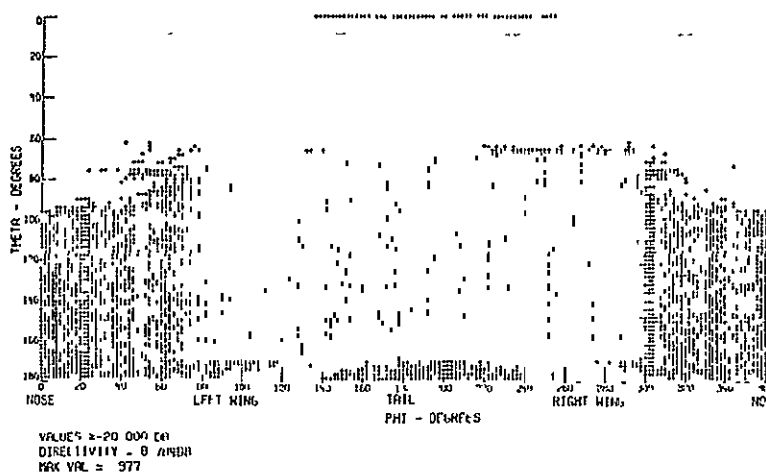
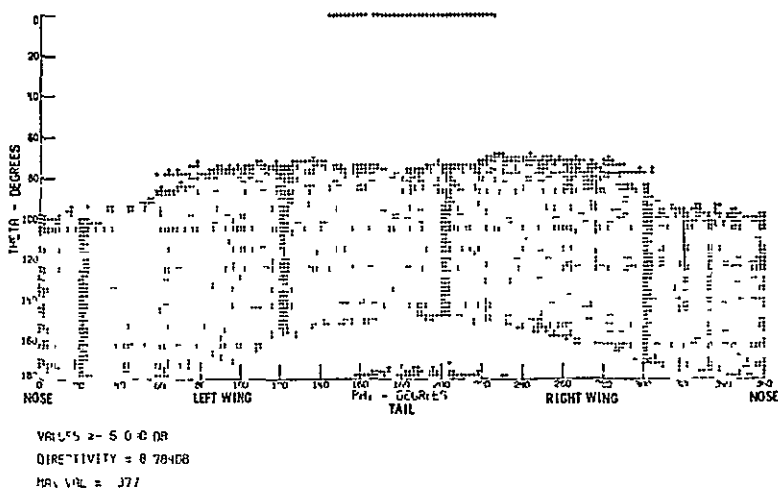
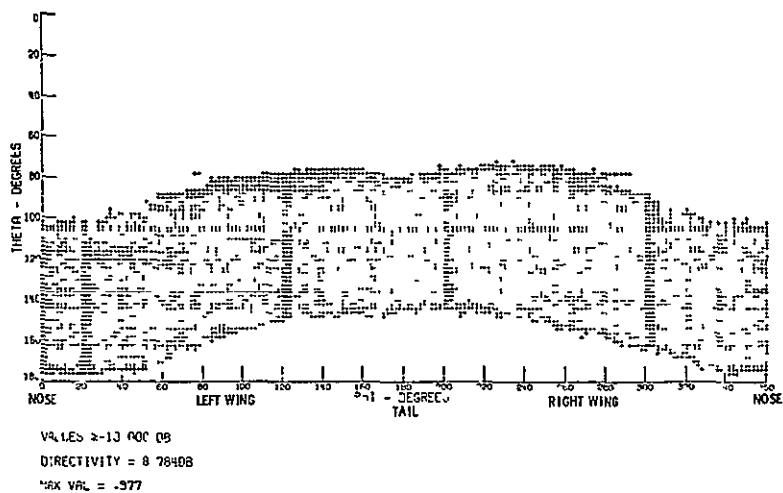

(q) Concluded.

Figure A-1.- Concluded.