

*copy 11 11 51 19*

# (REPRODUCIBLE COPY (FACILITY CASEFILE COPY)

The University of Alabama in Huntsville  
School of Graduate Studies and Research  
P.O. Box 1247  
Huntsville, Alabama 35807

*file with  
N77-11617*

Earth and Ocean Modeling  
(12/1/74 - 9/15/76)

Final Technical Report  
Contract NAS8-31194  
(1-A-59-51033 (1F))

By

Francis M. Knezovich  
Principal Investigator

Prepared for

George C. Marshall Space Flight Center  
National Aeronautics and Space Administration  
Marshall Space Flight Center, Alabama 35812

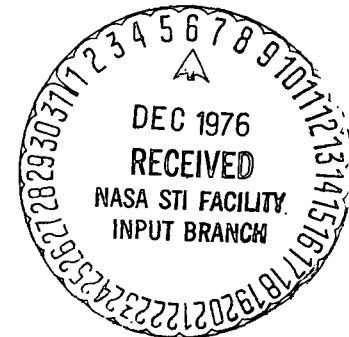

The University of Alabama in Huntsville  
School of Graduate Studies and Research  
P.O. Box 1247  
Huntsville, Alabama 35807

Earth and Ocean Modeling  
(12/1/74 - 9/15/76)

Final Technical Report  
Contract NAS8-31194  
(1-A-59-51033(1F))

By

Francis M. Knezovich  
Principal Investigator

Prepared for

George C. Marshall Space Flight Center  
National Aeronautics and Space Administration  
Marshall Space Flight Center, Alabama 35812

**Page**  
**Intentionally**  
**Left Blank**

## TABLE OF CONTENTS

	Page
List of Tables . . . . .	v
List of Figures . . . . .	vi
Chapter 1 Introduction . . . . .	1
1.1 General Background . . . . .	1
1.2 Objectives and Scope . . . . .	3
1.3 Outline of Report . . . . .	7
Chapter 2 Geophysical Considerations and Concepts . . . . .	8
2.1 General . . . . .	8
2.2 Reference Frames and Transformations . . . . .	19
2.2.1 Geographic Frame . . . . .	19
2.2.2 Inertial Frame . . . . .	20
2.2.3 Geodetic and Associated Frames . . . . .	24
2.2.4 Astronomic Frames . . . . .	27
2.3 Vector Relationships Applicable to Plate Motions . . . . .	28
2.4 Complex Parameters for Excitation Functions . . . . .	31
2.5 Interpolation Formula . . . . .	32
2.6 Spherical Harmonics . . . . .	32
2.7 The Normal Potential . . . . .	33
2.8 Love Numbers and Applications . . . . .	37
2.9 Tidal Force . . . . .	42
2.10 Precession and Nutation . . . . .	43
2.10.1 Louiville Equation . . . . .	43

	Page
2.10.2	Dynamic Equations for the Precession . . . . . 44
2.10.3	Precession and Nutation for a Rigid Earth . . 45
2.10.4	Correction for a Deformable Earth . . . . . 53
2.11	Plate Tectonics . . . . . 53
2.12	Atmospherics Applied to Polar Wobble . . . . . 58
2.13	Earth Rotation . . . . . 59
2.14	Polar Wobble . . . . . 66
2.15	Earth Tides . . . . . 85
2.16	Ocean Tides . . . . . 93
2.17	Geomagnetic Field . . . . . 98
2.17.1	General Note . . . . . 98
2.17.2	Geomagnetic Nomenclature and Relationships . . 98
2.17.3	Geomagnetic Field . . . . . 101
2.18	Gravity . . . . . 103
Chapter 3	Earth and Ocean Modules . . . . . 107
3.1	General Design . . . . . 107
3.2	Input-Output Modes . . . . . 111
3.3	Geophysical Module Details . . . . . 114
3.3.1	Precession Module . . . . . 114
3.3.2	Polar Wobble Module . . . . . 116
3.3.3	Earth Rotation Module . . . . . 118
3.3.4	Earth Tide Module . . . . . 119
3.3.5	Ocean Tide Module . . . . . 120

	Page
3.3.6 Plate Tectonics Module . . . . .	121
3.3.7 Geomagnetic Module . . . . .	122
3.3.8 Gravity Module . . . . .	122
Chapter 4 Applications of the Earth and Ocean Model	123
4.1 General Note on Applications . . . . .	123
4.2 Polar Wobble Study . . . . .	124
Chapter 5 Summary of the Earth and Ocean Modeling Program . . . . .	131
References . . . . .	132

LIST OF TABLES

Table		Page
2.1	Properties of Earth Model B . . . . .	9
2.2	Spectrum of Changes in the Earth's Rotation . .	15
2.3	Mechanisms with Effects now Distinguishable on the Earth's Rotation . . . . .	16
2.4	Tectonic Plate Parameters . . . . .	55
2.5	Excitation Functions $\Psi_3$ . . . . .	62
4.1	Earthquake Induced Polar Wobble Steps . . . . .	127

## LIST OF FIGURES

Figure		Page
2.1	Inertial Rotating Frames . . . . .	21
2.2	CIO-Polar Axis Relationship . . . . .	23
2.3	Latitude Definitions . . . . .	26
2.4	Rotation Diagrams . . . . .	29
2.5	Tidal Force . . . . .	42
2.6	Ecliptics and Equinoxes of Epoch and Date . .	49
2.7	Tectonic Plate Boundaries . . . . .	57
2.8	Power Spectra (Without Filter) . . . . .	78
2.9	Power Spectra (With Hann Filter) . . . . .	79
2.10	Power Spectra (Without Filter) . . . . .	80
2.11	Power Plot (With and Without Annual Component	80
2.12	ILS vs. BIH Polar Plot . . . . .	82
2.13	M <sub>2</sub> Amphidromic System . . . . .	96
2.14	Geographic to Geomagnetic Coordinate Conversion	99
3.1	Block Diagram of EOM . . . . .	108
3.2	Flow Diagrams . . . . .	109
3.3	Flow Diagram of Four-Module System . . . . .	112
3.4	EOMPMA Subroutine Calling Sequence . . . . .	114
3.5	EOMETTA Subroutine Calling Sequence . . . . .	120
4.1	Polar Wobble Plot 1 . . . . .	128
4.2	Polar Wobble Plot 2 . . . . .	129
4.3	Polar Wobble Plot 3 . . . . .	130



## Chapter 1

### INTRODUCTION

#### 1.1 General Background

The concept of an Earth and Ocean Model, in itself, is nothing new. Every development program involving missiles, satellites, geodesy, etc., must take into account one or more geophysical influences, each of which must be mathematically modeled. The degrees to which these influences are considered and related within the model are variable but important factors.

Most models ancillary to development programs have been restricted in scope and generally confined to one-time application. Traditionally, this is a result of limitations in accuracy and scope of measuring systems and consequent inability to isolate interrelated geophysical phenomena. It has long been known in theory that separated points on the Earth's surface were in relative oscillatory motion, but these motions were in the decimeter range and, from the viewpoint of measuring potential, could not be discriminated from the "solid" Earth.

The advent of artificial satellites and of sophistication in electromagnetic measuring devices and transportable time standards afforded the potential and imminent realization of intercontinental geodetic measurements to precisions in the centimeter range. This was formally recognized and documented

at a seminar conducted in August 1969. The report (Kaula 1970)) defined the existing and anticipated State-of-the-Art, and was a basis for an Earth and Ocean Physics Application Program (EOPAP).

The EOPAP as described in the contract has been developed to study and utilize the discipline of Earth dynamics for the benefit of science and mankind. Earth dynamics include solid-Earth and ocean dynamics, which are concerned with physical motions, and distortions of the Earth and physical state of the ocean. Solid-Earth dynamics include forces responsible for earthquakes, tidal waves, volcanic eruptions, mineral differentiation and mountain building. Ocean dynamics embraces ocean circulation and physical state of the ocean surface. A thorough understanding of Earth dynamics is fundamental to intelligent management of the Earth and its impact on our scientific knowledge and application. Progress in solving the problems of environmental management and alleviation of natural disasters will be quite limited until a better understanding has been achieved of physical mechanisms that respond to these forces. Earth and ocean dynamics are enormously complex, involving important interactions between components in different parts of the globe, and in the atmosphere, oceans and solid Earth. This precludes any probability of finding solutions in terms of simple theoretical descriptions. Determination of the probability of catastrophic natural events will almost certainly have to be based on strongly empirical numerical computer models that require,

as operational inputs, very large numbers of current synoptic data. This computer model was intended to identify the need and mission requirements for flight systems to interface with the user's requirements; to interrelate various geophysical and oceanographical phenomena, and to systematically catalog and store data for ready recall and application. The tasks of developing and applying a satellite system for a World-wide network of data points will be impossible without such a method of correlating and analyzing the collected information.

## 1.2 Objectives and Scope

The major objective of this study was to identify and formulate an Earth and Ocean Model (EOM) for use in the EOPAP and to develop a system that would supply information to the user for applying physical data gathered on a World-wide basis. It was intended that this would lead to the development of theoretical and empirical formulae which could be used to determine physical forces and influences of geophysical and oceanographical phenomena.

The EOM is effectively a modular structured system of computer programs utilizing Earth and ocean dynamical data keyed to finitely defined parameters. The model is an assemblage of mathematical algorithms with an inherent capability of maturation with progressive improvements in observational data frequencies, accuracies and scopes. The programs provide facilities for accepting a broad spectrum of data, not only

for evaluation of equation coefficients but for incidental storage and retrieval for later program extensions. To insure a simple yet practical method for updating geophysical constants and parameters, the values which were selected are listed in Appendix A and, for the computations, are isolated in a block data subroutine. This provides a ready means for positive, one-point entry for updating program parameters. The main program interfaces data input with appropriate module subprograms and controls interrelated routines.

It was originally intended that the EOM would include the following geophysical modules:

- a. Plate tectonics;
- b. Earth rotation and polar motions;
- c. Ocean currents;
- d. Ocean tides;
- e. Earth tides;
- f. Magnetic fields;
- g. Gravity;
- h. Atmospheric motion;
- i. Sea state; however, during the investigation

it was established that ocean currents and sea states were not amenable to practical modeling - the former, since there appeared to be considerable disagreement in the literature (and between oceanographers) of critical transport phenomena, and the latter, because of a real-time dependency on short-term variations in the atmospheric mechanism. Required computing facilities would be far beyond the scope of the EOM

program.<sup>1</sup> Atmospheric motion was restricted to its effect on Earth rotation and polar motion.<sup>2</sup>

A geodetic system where relative coordinates of widely separated points on the non-rigid, deformable Earth's surface are instantaneously determined to centimeter accuracies requires not only a recoverable and stable reference system but also a means for identifying the short- as well as long-period variations from the equilibrium Earth figure. The requirement for the former was the principal concern at an International colloquium on reference coordinate systems.<sup>3</sup> The following keynote was presented by Lundquist (1974):

"The current need for more precisely defined reference coordinate systems arises for geodynamics because the Earth can certainly not be treated as a rigid body when measurement uncertainties reach the few centimeter scale or its angular equivalent. At least two coordinate systems seem to be required. The first is a system defined in space relative to appropriate astronomical objects. This system should approx-

---

<sup>1</sup> The matter of ocean currents and sea states was discussed with the Director, Space Sciences Lab., MSFC, and the COR. It was decided to delete the ocean current and sea state modules.

<sup>2</sup> Atmospheric motion is determined by processing continuously available meteorological data. Global limitations (political and physical) preclude proper distribution and frequency of observation stations. This radically limits the effectiveness of atmospheric motion determinations for other than localized treatment, and are consequently unsuitable for the EOM application; however, the synoptic effects of atmospheric motion are reflected in Earth rotation variation and polar motion and can be evaluated from statistical analysis of these effects. (Approved at meeting described in <sup>1</sup>, above.)

<sup>3</sup> International Colloquium on Reference Coordinate Systems for Earth Dynamics, Torun, Poland, August 1974.

imate an inertial reference frame, or be accurately related to such a reference, because only such a coordinate system is suitable for ultimately expressing the dynamical equations of motion for the Earth. The second required coordinate system must be associated with the non-rigid Earth in some well-defined way such that the rotational motions of the whole Earth are meaningfully represented by the transformation parameters relating the Earth system to the space-inertial system. The Earth system should be defined so that the dynamical equations for relative motions of the various internal mechanical components of the Earth and accurate measurements of these motions are conveniently expressed in this system."

It was accordingly decided to include a precession module as an extension of the polar motion module and to treat the Earth rotation in a separate module. The modules which were actually modeled and their program names are as follows:

- a. Plate tectonics (EOMPPTA)
- b. Earth rotation (EOMERA)
- c. Polar wobble (EOMPWA)
- d. Precession (EOMPMA)
- e. Ocean tides (EOMOTA)
- f. Earth tides (EOMETA)
- g. Magnetic fields (EOMMFA)
- h. Gravity (EOMGMA)

The rather large excursions and somewhat periodic secular motion of the Chandler polar path was investigated in some detail. It was demonstrated that both could be attributed to internal Earth's mass redistributions marked by large earthquakes.

### 1.3 Outline of Report

Geophysical considerations relating to development of the EOM modules are described in Chapter 2; assumptions, simplifications, and acceptance of specific theories are discussed in sufficient detail to define and validate adopted approaches and associated provisions. Chapter 3 contains mathematical and physical details involved with assembling the individual EOM modules, as well as limitations and potential for further development. Chapter 4 presents UNIVAC 1108 system FORTRAN V programming details for the EOM modules to include a comprehensive indexing of computer materials. Applications of the EOM and factors bearing on future extension are discussed in Chapter 5, including the investigation of the power source for the polar wobble mechanism. Chapter 6 provides a summary of the EOM program and appropriate recommendations and conclusions.

## Chapter 2

### GEOPHYSICAL CONSIDERATIONS AND CONCEPTS

#### 2.1 General

The Earth's interior has been and still is a largely undetermined geophysical variable; however, seismic techniques (Takeuchi, et al. (1967)) have provided bases for assumptive but fairly conclusive determinations of the internal structure. Supporting the atmosphere and hydrosphere is a relatively thin crust enclosing, first, a mantle, and then a core. Crust and mantle are solid while the core is taken to be liquid (outer core) with the deeper part (inner core) generally considered to be solid. The mantle-crust boundary is marked by a significant change in constituent material called the Mohorovičić discontinuity after its original discoverer. The crust thickness varies over the Earth from about 5 kilometers under oceans to about 70 kilometers beneath mountains. The average continental crust thickness is about 35 kilometers. There are several published models for the internal properties of the Earth, but Earth Model B (Bullen (1963)), shown in Table 2.1, is representative. The outer core is assumed to act as a self-exciting dynamo. The dynamo theory, first suggested by J. Larmor in 1919, was worked out in detail by W.M. Elsasser and E.C. Bullard (Rikitake (1966)) following World War II. The principal portion of the geomagnetic field is due to this influence of the core and the



Table 2.1 Properties of Earth Model B

Depth	$\rho$	p	k	$\mu$	g
33	3.32	0.009	1.16	0.63	985
80	3.36	0.025	1.22	0.66	986
80	3.87	0.025	(1.40)	(0.76)	986
200	3.94	0.071	(1.58)	(0.83)	985
400	4.06	0.150	(1.92)	(0.99)	983
600	4.18	0.231	(2.61)	(1.34)	980
1000	4.41	0.400	3.37	1.78	976
1400	4.63	0.58	3.96	2.03	976
1800	4.84	0.76	4.58	2.25	982
2200	5.03	0.96	5.26	2.48	997
2600	5.22	1.16	5.89	2.71	1010
2700	5.27	1.22	6.13	2.81	1042
2898	5.57	1.33	6.40	2.97	1069
2898	9.74	1.33	6.4	0.0	1069
3500	10.60	1.95	8.2	0.0	937
4000	11.16	2.42	10.1	0.0	815
4500	11.63	2.85	11.6	0.0	647
4982	12.00	3.22	12.1	0.0	607
5121	15.4	3.33	13.6	(3.2)	573
6371	18.1	3.95	16.4	(5.0)	0

Depth in kilometers;  $\rho$  is the density in  $\text{g/cm}^3$ ; p is the pressure  $\times 10^{12}$  dynes/cm<sup>2</sup>; k is the incompressibility and  $\mu$  the rigidity, respectively, in the same units as p; g is the acceleration of gravity in cm/sec<sup>2</sup>. Discontinuities indicated at 80, 2898, and ca. 5050 kilometers represent crust-mantle-outer core-inner core.

remainder, minute and highly localized, due to remanent magnetizations in the crust. There is strong evidence that the core rotates at a different rate than the mantle-crust system. This is manifested in a westward drift of the geomagnetic field and in variations in Earth rotation rate which may be due to momentum conservation for varying core-mantle relative angular velocities.

There is, of course, much more known about the Earth's surface. A continuing mystery, which seems to have been fairly resolved only in the last decade, concerned paleoecologists' efforts to account for inconsistencies in distribution of land masses and of ancient flora and fauna. The first scientifically reasonable explanation, in terms of continental drift, was given in 1915 by A. Wegener (Wegener (1924)).<sup>4</sup> His theory was not immediately accepted mainly for lack of a scientifically plausible explanation for the driving forces required to move continental masses. Continental drift theorists were eventually opposed by polar wandering theorists,<sup>5</sup> with a third group accepting a combination of the two (Hapgood (1970)). There is now a consensus for continental drift in its scientifically structured form known as plate tectonics.

Plate tectonics are concerned with the tectonic activities of an Earth's surface divided into a mosaic of rigid, shifting

---

<sup>4</sup> English translation of the original "Die Entstehung der Kontinente and Ozeane", Brunswick, Germany (1915).

<sup>5</sup> Polar wandering assumes the outer shell to be intermittently shifting about the poles moving continents collectively. Continental drift treats continental motions as individual.

plates. There are 14 major plates whose boundaries are associated with a seismically active variety of characteristic features such as rift valleys, oceanic ridges, mountain belts, volcanic chains and deep oceanic trenches. Oceanic ridges mark regions where adjacent plates are being pulled apart and new surface material is formed from cooling magma. Oceanic trenches are formed by one of the two plates plunging steeply into the Earth below the other. The total effects of these actions are to maintain a constant Earth's surface area and to displace surface features in varying degrees with respect to an absolute geodetic datum.

It has been estimated from seismic data that plates are from 70 to 150 kilometers thick and, accordingly, not related to the mantle-crust differentiation marked as the Mohorovičić discontinuity. Best evidence indicates that they form a rigid layer overlying a weaker, hotter layer which becomes increasingly viscous with depth. The supporting surface is called the asthenosphere. Plate boundaries move at relative velocities of from 1 to 10 centimeters per year. Since this motion is on the surface of a sphere the relative motions of any two plates can be described by a rotation around a single axis passing through the sphere's center. Given the absolute motion of any one plate with respect to a set of fixed points within the mantle, the absolute motion of all the plates can be determined from knowledge of the individual relative plate motions. Appropriate processes for this are described by Dewey (1972) and Solomon and Sleep (1974).

The sea-level surface of the Earth very nearly conforms to an ellipsoid of revolution with equal equatorial axes. If the axis of rotation is along a principal axis, the angular momentum vector is coincident. It was suggested by Euler (1765) that if a rigid figure did not rotate about a principal axis, a free nutation would result as a function of the principal moments of inertia. For Earth values this would have a period of about ten months. It was reported by Chandler (1891), after an extensive study of latitude variation periodicity, that a ten-month period did not exist; instead, there was an annual term and a second term of about fourteen months. It was shown by Newcomb (1892) that this unexpected increase from ten to fourteen months was due to mobility of the oceans and an elastic yielding of the Earth. This non-annual nutation or polar wobble<sup>6</sup> is now known as the Chandler wobble.

The angular momentum vector, in the absence of external forces on the Earth would retain a fixed orientation in inertial space. It lies within the plane formed by the axes of rotation and figure, very nearly coinciding with the former. The rotating Earth is subject to gravitational forces of Sun, Moon and planets, and the subsequent gyroscopic effect results in precessional motions<sup>7</sup> of the angular momentum vector. The

---

<sup>6</sup> Polar wobble is considered to be the trace of the rotation axis with respect to some axis on the Earth's surface to which latitude stations are referenced. Polar wobble is thus manifest in terms of latitude changes.

<sup>7</sup> Precession is a measure of the motion of the angular momentum vector through the celestial sphere. The axis remains inclined at approximately the same angle to the ecliptic plane and is manifest in declination changes for the stars.

process is complicated by non-coincidence of axes of rotation and figure, deformation of a yielding Earth by gravitational forces, and seismically induced mass redistributions in the heterogeneous structure of crust and mantle.

The Earth's rotation rate is influenced by external torques, changes in inertial moments, wind stress and core-mantle coupling. External torques include effects of Earth and ocean long-period tides, gravitational torques on the equatorial bulge, and the solar wind. Changes in inertial moments include seismically induced internal mass redistributions, surface level changes brought about by polar ice and sea level fluctuations, and atmospheric mass transport. Variations in the rotation rate are monitored by astronomic time observations and, more precisely, by utilizing such techniques as the Very Long Base Interferometric (VLBI) procedure for observing on extragalactic radio stars (Gold (1967)).

The entire Earth's surface is in continuous, relative, periodic and systematic motion, and there are no direct means for selecting and maintaining an absolute geodetic reference system which can be readily and positively recovered. Since the reference system must be available at the surface, the best solution is to find an approach which minimizes undetectable displacements. An ideal system would have the origin at the Earth's center of mass and three or more axes aligned toward selected extragalactic radio sources. The origin is readily recoverable through appropriate satellite observations. The same would be true of the inertial axes using

VLBI except for the lack of a sufficiently accurate means for relating them to the stellar system. The present choice is to set the origin at the Earth's center of mass, the z axis toward a point known as the Conventional International Origin (CIO)<sup>8</sup>, the x axis orthogonal to the z and pointing toward a prime meridian defined by the Bureau Internationale de l'Heure (BIH)<sup>9</sup> in Paris. The y axis completes the orthogonal set, the positive direction pointing toward 90° E. longitude. It should be noted that geophysicists utilize this right-handed system, while astronomers choose the positive y direction toward 90° W. longitude.

Rochester (1973) has tabulated the spectrum of changes in Earth's rotation and associated geophysical mechanisms. These are presented in Tables 2.2 and 2.3, respectively. Elements in columns A, B and C of Table 2.2 are discussed in detail in Sections 2.10, 2.14 and 2.13, respectively.

The Earth's elastic properties can be effectively summarized in a set of dimensionless parameters known as Love numbers. Love (1909) introduced the numbers h and k to characterize the various aspects of Earth tides. His theory was keyed to the concept that since the tidal potential can be adequately represented by a second-degree spherical harmonic function, all deformations due to this potential may be eval-

---

<sup>8</sup> The CIO is defined as the average position of the true celestial pole from 1900 to 1905 as determined from adopted latitudes of the International Latitude Service (ILS) latitude stations.

<sup>9</sup> The BIH determines changes in adopted observatory longitudes necessary to maintain an absolute prime meridian that is not necessarily the same as the Greenwich meridian.

Table 2.2 Spectrum of Changes in the Earth's Rotation

A. Inertial Orientation of Spin Axis	B. Terrestrial Orientation of Spin Axis (Polar Motion)	C. Instantaneous Spin Rate $\dot{\omega}$ About Axis
<p>1. Steady precession: amplitude <math>23^{\circ}.5</math>; period <math>\approx 25,700</math> years.</p> <p>2. Principal nutation: amplitude <math>9^{\circ}.20</math> (obliquity); period 18.6 years.</p> <p>3. Other periodic contributions to nutation in obliquity and longitude: amplitudes <math>&lt; 1''</math>; periods 9.3 years, annual, semiannual, and fortnightly.</p> <p>4. Discrepancy in secular decrease in obliquity: <math>0^{\circ}.1</math>/century(?).</p>	<p>1. Secular motion of pole: irregular, <math>\approx 0^{\circ}.2</math> in 70 years.</p> <p>2. 'Markowitz' wobble: amplitude <math>\approx 0^{\circ}.02</math>(?); period 24-40 years(?).</p> <p>3. Chandler wobble: amplitude (variable) <math>\approx 0^{\circ}.15</math>; period 425-440 days; damping time 10-70 years(?).</p> <p>4. Seasonal wobbles: annual, amplitude <math>\approx 0^{\circ}.09</math>; semiannual, amplitude <math>\approx 0^{\circ}.01</math>.</p> <p>5. Monthly and fortnightly wobbles: (theoretical) amplitudes <math>\approx 0^{\circ}.001</math>.</p> <p>6. Nearly diurnal free wobble: amplitude <math>\leq 0^{\circ}.02</math>(?); period(s) within a few minutes of a sidereal day.</p> <p>7. Oppolzer terms: amplitudes <math>\approx 0^{\circ}.02</math>; periods as for nutations.</p>	<p>1. Secular acceleration: <math>\dot{\omega}/\omega \approx -5 \times 10^{-10}/\text{Yr}</math>.</p> <p>2. Irregular changes: (a) over centuries, <math>\dot{\omega}/\omega \leq \pm 5 \times 10^{-9}/\text{Yr}</math>; (b) over 1-10 years, <math>\dot{\omega}/\omega \leq \pm 80 \times 10^{-10}/\text{Yr}</math>; (c) over a few weeks or months ('abrupt'), <math>\dot{\omega}/\omega \leq \pm 500 \times 10^{-10}/\text{Yr}</math>.</p> <p>3. Short-period variations: (a) biennial, amplitude <math>\approx 9</math> msec; (b) annual, amplitude <math>\approx 20-25</math> msec; (c) semiannual, amplitude <math>\approx 9</math> msec; (d) monthly and fortnightly, amplitudes <math>\approx 1</math> msec.</p>

Table 2.3 Mechanisms with Effects now Distinguishable  
on the Earth's Rotation

Mechanism	Effect*
Sun	
Gravitational torque	A, B7, C1, C3c
Solar wind torque	C2c(?)
Moon	
Gravitational torque	A, B7, C1, C3d
Mantle	
Elasticity	B1, B3-4, C1-2a, C3c-d
Earthquakes	B1, B3
Solid friction	B3(?), C1
Viscosity	C2a
Liquid core	
Inertial coupling	A2-3, B2, B6
Topographic coupling	C2b-c(?)
Electromagnetic coupling	A4(?), B3, C2
Solid inner core	
Inertial coupling	B2(?)
Oceans	
Loading and inertia	B1, B3, B5, C2a
Friction	B3(?), C1
Groundwater	
Loading and inertia	B4
Atmosphere	
Loading and inertia	B4
Wind stress	C2c, C3a-c
Atmospheric tide	C1

\* Letters and numbers refer to Table 2.2



uated by multiplying the harmonic function by the appropriate Love number; e.g., the Earth surface is raised by  $\frac{U}{g} \cdot h$ , where  $U$  is the surface potential and  $g$  is the acceleration of gravity. The consequent gravitational potential is given by  $U \cdot k$ . The horizontal analogue of the Love numbers,  $\ell$ , was suggested by Shida and Matsuyama (1912). It is generally treated as an additional Love number. Application of the Love numbers are discussed in detail in Section 2.8.

Although the point has been made that the Earth is not a rigid body and must be treated apart from rigid body theory, the departures from rigidity are sufficiently small to be considered as perturbations to the rigid body solutions. Since these solutions are well known, a combination of perturbation technique and Love number application provides a completely adequate treatment. An effective approach was presented by Munk and MacDonald (1960) and is adopted in this study.

The theoretical influences of lunar and solar potential on an elastic Earth are conveniently expressed in terms of spherical harmonics. Laplace (1796-1825) separated the potential into three groupings; he called these the tides of the first, second and third type which are uniquely representable as zonal, tesseral and sectorial harmonics, respectively (See Section 2.15). (These correspond to long-period, diurnal and semi-diurnal periods, respectively.) The total tide represents the sum contributions of all its components at a specified time and place. Component arguments can be expressed in

terms of six independent astronomical variables. There are 31 principal components (Melchior (1966)) with relative amplitudes ranging from 910 to 3. The practical majority of the tide can be determined by using three long-period, three diurnal and three semi-diurnal components.

A reasonable solution for the Earth tide can be obtained using second-degree spherical harmonics if Love numbers are utilized to account for elasticity, and some lag factor is introduced to account for delay in Earth-potential response time.

The situation is much more involved for ocean tides which include the open ocean (pelagic) tides as well as the more familiar ones in the vicinity of land masses. The indicated approach for the Earth tide is essentially a static one which can not be applied to the ocean tide. The principal problems are Earth's rotation (Coriolis effect) and the limiting effect of ocean depth on tidal wave speed. Ignoring the Coriolis forces for the moment, a direct response of the ocean to lunar or solar gravitational attractions requires that the bulge travels at the same speed as the attracting body. If it does so, the result is known as the direct tide; however, the tidal wave speed is dependent upon water depth and the bulge can fall behind, leading to a 90 degree phase shift and an inverted tide. Since the apparent speed of the attracting body is a function of latitude this would, by itself, lead to radical discontinuities in ocean levels and mass transport.

This, of course, does not occur, but the matter of dynamically evaluating the pelagic tide is a problem with no possible direct solution. Assumptions must be made of average water depths, optimized boundary configurations, transport processes, etcetera. Boundary conditions are the observed tides at or near land masses. In practice, solutions are made for separate components, each of which is manifest as an amphidromic system (See Section 2.16).

## 2.2 Reference Frames and Transformations

### 2.2.1 Geographic Frame:

The first considered reference frame is a set of axes rotating with the Earth. There are several possibilities, but the most feasible and readily implemented system is a set of orthogonal axes defined by the coordinates of a network of observatories. In this sense the axes are fixed to the solid Earth and rotate with it. The existence of a deforming Earth and its effect on a rigid set of axes imposes a requirement that the observatory coordinate definition be modified to include provisions for variations due to oscillatory and secular motions.

The z axis, which very nearly represents the rotation axis, is defined as the Conventional International Origin (CIO). The CIO was adopted in 1967 by the International Astronomical Union (IAU) and the International Union of Geodesy and Geophysics (IUGG). It set the pole to the average position defined by the five stations of the International

Latitude Service (ILS) for the period 1900-1905. The Bureau Internationale de l'Heure (BIH) converted their system to the CIO by adjusting the BIH polar paths to those of the ILS for the years 1964-1966. The x axis is orthogonal to the z axis and in the plane of a zero meridian determined by longitude (time) observations of the BIH. The y axis is orthogonal to the xz plane and considered here as positive in the direction of  $90^{\circ}$  E. longitude.

The BIH utilizes data from its latitude and longitude stations and from the Dahlgren Polar Monitoring Service (DPMS) to provide continuous observatory updates for long-period and secular Earth motions. Provisions for higher frequency motions are made in the data reduction processes of the individual observatories.

The coordinate origin is the Earth's center of mass. This is readily recoverable through satellite observations.

#### 2.2.2 Inertial Frame:

The inertial reference system is made up of three orthogonal axes oriented with respect to the ecliptic and vernal equinox of some selected epoch. Here the epoch of choice is 1950.0 or the Julian date, 2433282.5. The inertial reference system is related to the Earth-fixed rotating system through the three Euler angles. The relationship of the two frames is shown in Figure 2.1. The positive directions of the Euler angles  $\theta$ ,  $\phi$  and  $\psi$  are indicated in the figure. The dots over the Euler elements indicate the time derivatives. The

Figure 2.1 Inertial-Rotating Frames

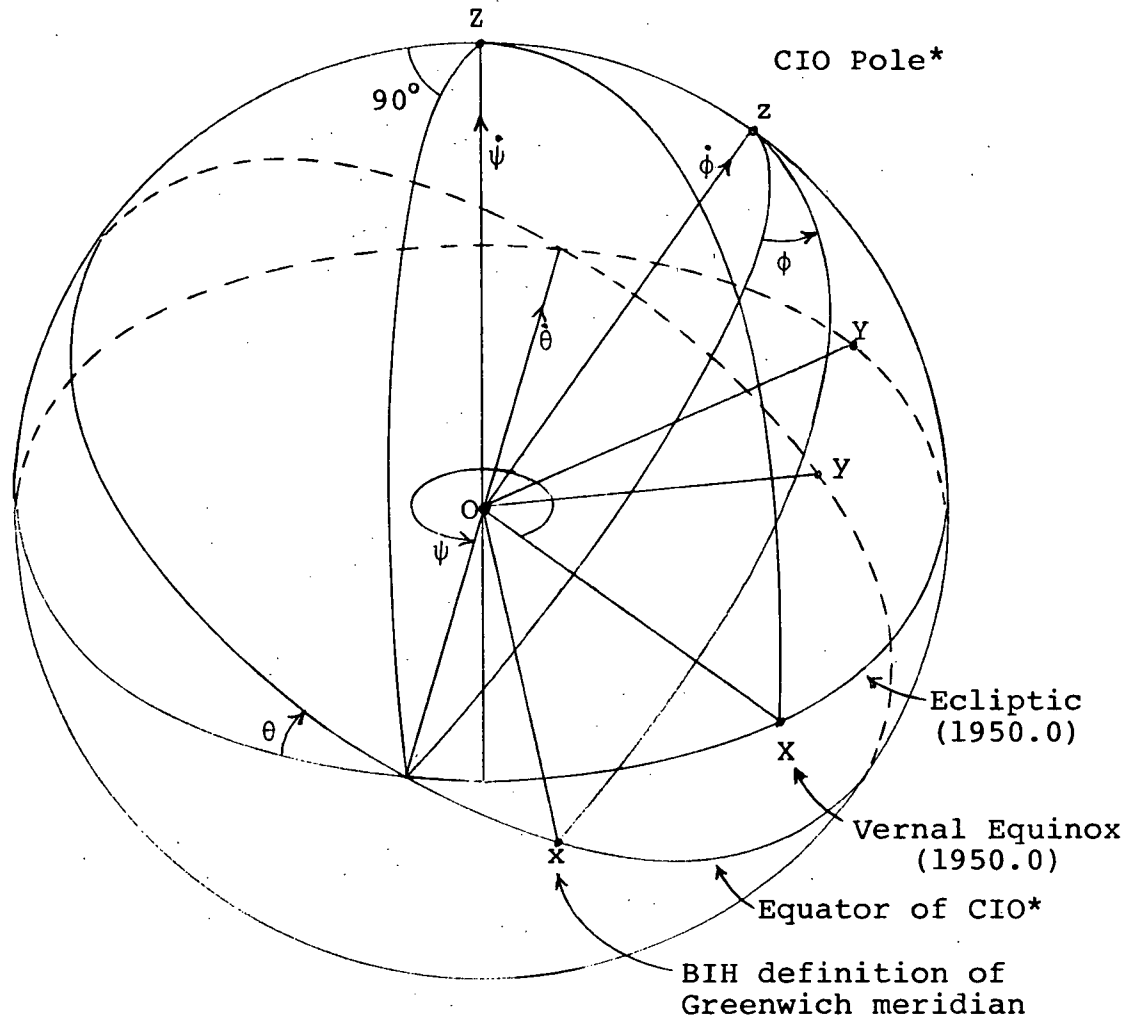

\* Figure presents an assumption that the CIO axis remains an axis of figure. In practice, the CIO axis is replaced by the minor axis of figure, and the CIO equator is defined by the major axes of figure.

inertial axes are  $X, Y, Z$ ; rotating axes are  $x, y, z$ .

The kinematical relationships of the Euler angle derivatives are developed by adding details of Figure 2.2 to those of Figure 2.1. The axes  $x, y, z$  of Figure 2.2 repeat those of Figure 2.1. The additional axes are the angular momentum axis  $OH$  and the instantaneous rotation axis  $OP$ . (Note that  $H$  lies on the great circle arc  $zP$ .) It can be seen from the two figures that

$$\begin{aligned}\omega_1 &= \omega \sin \gamma \cos \Gamma, \\ \omega_2 &= \omega \sin \gamma \sin \Gamma, \\ \omega_3 &= \omega \cos \gamma,\end{aligned}\tag{1}$$

where  $\omega_i$  is the polar rotation vector, the components 1,2,3 representing  $x, y, z$ , respectively;  $\omega$  is the rotation vector magnitude and  $\gamma$  and  $\Gamma$  are angles indicated in the figure. The rotations  $\omega_i$  which determine the motion of the CIO axis with respect to the instantaneous rotation axis represent the same motion as the Euler angle derivatives. These relations are found by resolving each of the vectors  $\dot{\theta}, \dot{\psi}, \dot{\phi}$  into its components along the CIO axis. The result is

$$\begin{bmatrix} \omega_1 \\ \omega_2 \\ \omega_3 \end{bmatrix} = \begin{bmatrix} -\sin\theta\sin\phi & -\cos\phi & 0 \\ -\sin\theta\cos\phi & \sin\phi & 0 \\ \cos\theta & 0 & 1 \end{bmatrix} \begin{bmatrix} \dot{\psi} \\ \dot{\theta} \\ \dot{\phi} \end{bmatrix}.\tag{2}$$

The inverse relationship is

Figure 2.2 CIO-Polar Axis Relationship

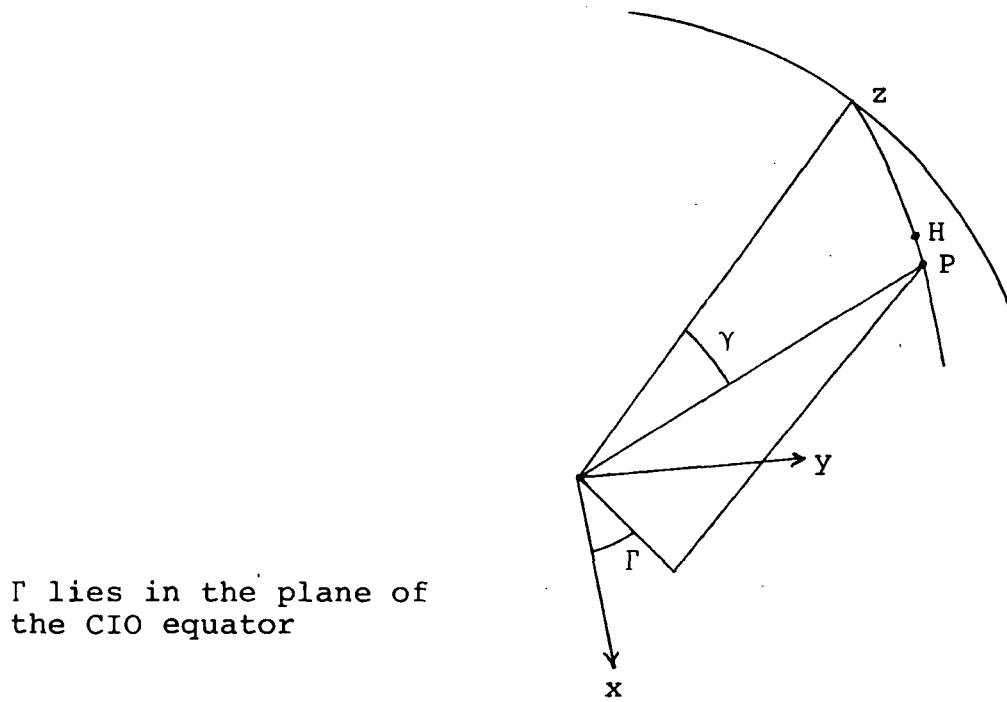

$$\begin{bmatrix} \dot{\psi} \\ \dot{\theta} \\ \dot{\phi} \end{bmatrix} = \begin{bmatrix} -\csc\theta\sin\phi & -\csc\theta\cos\phi & 0 \\ -\cos\phi & \sin\phi & 0 \\ \cot\theta\sin\phi & \cot\theta\cos\phi & 1 \end{bmatrix} \begin{bmatrix} \omega_1 \\ \omega_2 \\ \omega_3 \end{bmatrix} \quad (3)$$

Note that since  $\theta$  remains on the order of  $23^\circ.5$  no mathematical difficulties are presented by the first of Eq. (3).

The transformations between the  $X_i$  system and the  $x_i$  system obey the following relations:

$$x_i = a_{ij}x^j, \quad (4)$$

$$X_j = a_{ji}x^i, \quad (5)$$

where

$$a_{ij} = \begin{bmatrix} \cos\phi\cos\psi - \sin\phi\sin\psi\cos\theta & \cos\phi\sin\psi + \sin\phi\cos\psi\cos\theta & -\sin\phi\sin\theta \\ -\sin\phi\cos\psi - \cos\phi\sin\psi\cos\theta & -\sin\phi\sin\psi + \cos\phi\cos\psi\cos\theta & -\cos\phi\sin\theta \\ -\sin\psi\sin\theta & \cos\psi\sin\theta & \cos\theta \end{bmatrix}. \quad (6)$$

### 2.2.3 Geodetic and Associated Frames:

A geocentric system of coordinates can be expressed by the equations,

$$\begin{bmatrix} x \\ y \\ z \end{bmatrix} = \begin{bmatrix} (v+H) \cos\phi \cos\lambda \\ (v+H) \cos\phi \sin\lambda \\ [v(1-e^2)+H] \sin\phi \end{bmatrix}, \quad (7)$$

where:  $\phi$  is the geodetic latitude;  $\lambda$  is the longitude (positive in the eastern hemisphere);  $H$  is the height of the point above the ellipsoid, and

$$v = \frac{a}{(1-e^2\sin^2\phi)^{\frac{1}{2}}}, \quad (8)$$

$$e^2 = \frac{a^2 - b^2}{a^2}, \quad (9)$$

$$1 - e^2 = \frac{b^2}{a^2}, \quad (10)$$

with  $a$  and  $b$  the semi-major and semi-minor ellipsoid axes, respectively. The inverse of (7) is

$$\lambda = \tan^{-1}\left(\frac{y}{x}\right) \quad (11)$$

and the iterative solution of



$$\phi = \sin^{-1} \left[ \frac{z}{v(1-e^2)+H} \right] , \quad (12)$$

where  $\phi = \sin^{-1} \left( \frac{z}{v} \right)$  is introduced into  $v$  for the initial determination. The  $\phi$  in  $v$  must be successively updated until the increment in the determined  $\phi$  becomes negligible. When  $H=0$  the exact solution is

$$\phi = \tan^{-1} \left[ \frac{z \sin \lambda}{y(1-e^2)} \right] = \tan^{-1} \left[ \frac{z \cos \lambda}{x(1-e^2)} \right] . \quad (13)$$

The geocentric latitude  $\psi$  is given by

$$\psi = \tan^{-1} \left[ (1-e^2) \tan \phi \right] , \quad (14)$$

and for the radius vector  $\rho$ ,

$$\rho_e = a \left( \frac{\cos \phi}{\cos \psi \cos (\phi - \psi)} \right)^{\frac{1}{2}} \approx a(1-f \sin^2 \phi) ; \quad (15)$$

where the flattening  $f$  is

$$f = \frac{a-b}{a} , \quad (16)$$

for points on the ellipsoid surface. For points at elevations  $H$ ,

$$\rho_H \approx \rho_e + H . \quad (17)$$

Given geocentric rather than geodetic coordinates, the geocentric coordinates are

$$\begin{bmatrix} x \\ y \\ z \end{bmatrix} \approx \begin{bmatrix} \rho_H \cos \psi \cos \lambda \\ \rho_H \cos \psi \sin \lambda \\ \rho_H \sin \psi \end{bmatrix} . \quad (18)$$

The accuracy of (18) is improved by substituting  $\psi_H$  for  $\psi$  where  $\psi_H$  is given by

$$\psi_H \approx \tan^{-1} \left[ \frac{v(1-e^2)+H}{v+H} \tan\phi \right] . \quad (19)$$

The reduced latitude  $\beta$  for a point on the ellipsoid is given by

$$\beta = \tan^{-1} \left[ \frac{b}{a} \tan\phi \right] . \quad (20)$$

Ellipsoidal coordinates  $u, \theta, \lambda$  are related to rectangular coordinates by (where  $\theta = 90^\circ - \beta$ , the reduced latitude)

$$\begin{bmatrix} x \\ y \\ z \end{bmatrix} = \begin{bmatrix} (u^2+E^2)^{\frac{1}{2}} \cos\beta \cos\lambda \\ (u^2+E^2)^{\frac{1}{2}} \cos\beta \sin\lambda \\ u \sin\beta \end{bmatrix} = \begin{bmatrix} a \cos\beta \cos\lambda \\ a \cos\beta \sin\lambda \\ b \sin\beta \end{bmatrix}_{u=b} , \quad (21)$$

where  $E$  is the linear eccentricity,

$$E = (a^2 - b^2)^{\frac{1}{2}} . \quad (22)$$

Figure 2.3 Latitude Definitions

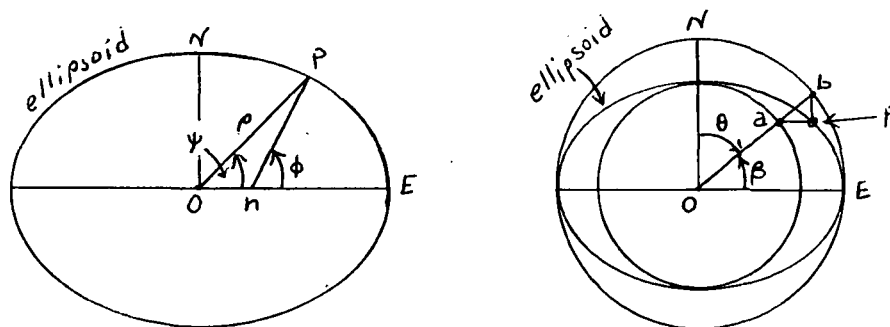

A. Geodetic and Geocentric Latitudes

B. Reduced Latitude

Altitude corrections of latitudes are given by (with H in meters),

$$\Delta\phi \approx 1''.71 H \sin^2\phi \times 10^{-4} \approx \Delta\beta \quad (23)$$

The latitudes are defined in Figure 2.3. In Figure 2.3A, the radius vector  $\rho$  is the length OP. The line nP is a normal to the ellipsoid surface. OE is the equatorial line intersected by the plane ONP. In Figure 2.3B, the line Ob equals  $(u^2 + E^2)^{\frac{1}{2}}$ , the line Oa equals u, and these two radii represent the semi-major and -minor axes of the ellipsoid surface. P, in both figures, is the observation point.

#### 2.2.4 Astronomic Frames:

The astronomic coordinate systems of interest here are the ecliptic and right ascension systems for some specified epoch or instant. The ecliptic system locates the astronomic body in respect to the ecliptic and vernal equinox; the right ascension system, in respect to the Earth's equator and vernal equinox. Ecliptic coordinates are latitude,  $\beta$ , and longitude,  $\lambda$ . Right ascension coordinates are declination,  $\delta$ , and right ascension,  $\alpha$ . The two systems are related by the equations

$$\cos\delta\cos\alpha = \cos\beta\cos\lambda \quad , \quad (24)$$

$$\sin\delta = \cos\beta\sin\lambda\sin\epsilon + \sin\beta\cos\epsilon \quad , \quad (25)$$

$$\cos\delta\sin\alpha = \cos\beta\sin\lambda\cos\epsilon - \sin\beta\sin\epsilon \quad , \quad (26)$$

$$\cos\beta\cos\lambda = \cos\delta\cos\alpha \quad , \quad (27)$$

$$\sin\beta = -\cos\delta\sin\alpha\sin\epsilon + \sin\delta\cos\epsilon \quad , \quad (28)$$

$$\cos\beta\sin\lambda = \cos\delta\sin\alpha\cos\epsilon + \sin\delta\sin\epsilon \quad , \quad (29)$$

where  $\epsilon$  is the obliquity of the ecliptic. Given the ecliptic parameters  $\beta, \lambda, \epsilon$ , the value of  $\delta$  is obtained from (25);  $\alpha$  is obtained after dividing (26) by (24). Given the right ascension parameters  $\delta, \alpha, \epsilon$ , the value of  $\beta$  is obtained from (28); the value of  $\lambda$  is obtained after dividing (29) by (27).

### 2.3 Vector Relationships Applicable to Plate Motions

Rotational components of an ellipsoid normal with coordinates  $\phi, \lambda$ , are given by

$$\begin{bmatrix} \omega_x \\ \omega_y \\ \omega_z \end{bmatrix} = \omega \begin{bmatrix} \cos\phi \cos\lambda \\ \cos\phi \sin\lambda \\ \sin\phi \end{bmatrix}, \quad (30)$$

$\omega = \omega_i \omega^i$  is the rotation magnitude and  $\omega_i$  the rotation vector. The displacement of a point moving on a plate rotating on an axis with coordinates  $\phi, \lambda$ , at a rate  $\omega_i$  can be established from the diagrams in Figure 2.4. The relationships associated with the diagrams are given with the figure. From these,

$$\begin{bmatrix} \Delta x \\ \Delta y \\ \Delta z \end{bmatrix} = t \begin{bmatrix} 0 & -\omega_z & \omega_y \\ \omega_z & 0 & -\omega_x \\ \omega_y & \omega_x & 0 \end{bmatrix} \begin{bmatrix} x \\ y \\ z \end{bmatrix}; \quad (31)$$

i.e.,

$$\Delta x_i = \epsilon_{ijk} \omega^j x^k t, \quad (31')$$

where  $\epsilon_{ijk}$  is the completely antisymmetric permutation tensor (refer to text on tensor calculus; e.g., Hotine (1969)).

Figure 2.4 Rotation Diagrams

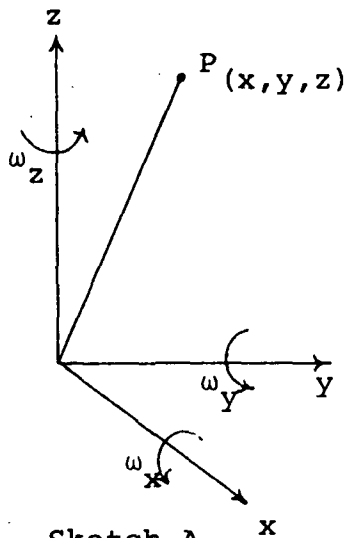

Sketch A

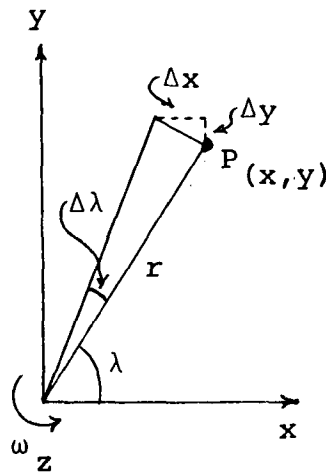

Sketch B

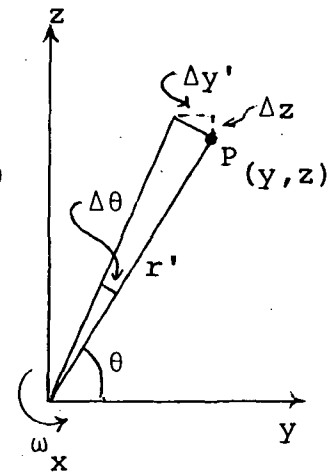

Sketch C

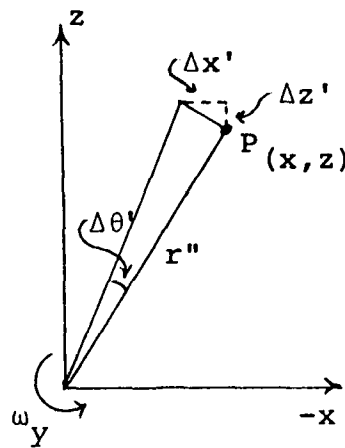

Sketch D

$$B: \lambda = \cos^{-1}\left(\frac{x}{(x^2+y^2)^{1/2}}\right) = \sin^{-1}\left(\frac{y}{(x^2+y^2)^{1/2}}\right)$$

$$\Delta\lambda = \omega_z t$$

$$s \approx r\Delta\lambda = (x^2+y^2)^{1/2}\omega_z t$$

$$\Delta x = -s \sin\lambda = -y\omega_z t$$

$$\Delta y = x\omega_z t$$

$$C: \theta' = \cos^{-1}\left(\frac{y}{(y^2+z^2)^{1/2}}\right) = \sin^{-1}\left(\frac{z}{(y^2+z^2)^{1/2}}\right)$$

$$\Delta\theta = \omega_x t$$

$$s' \approx r'\Delta\theta = (y^2+z^2)^{1/2}\omega_x t$$

$$\Delta y' = -s' \sin\theta = -z\omega_x t$$

$$\Delta z = y\omega_x t$$

$$D: \Delta x' = z\omega_y t$$

$$\Delta z' = -x\omega_y t$$

From Eq. (7) with  $H=0$  and setting  $(1-e^2)=1$  (noting that  $(1-e^2)\approx 0.9933$ ),

$$\begin{bmatrix} x \\ y \\ z \end{bmatrix} = v \begin{bmatrix} \cos\phi \cos\lambda \\ \cos\phi \sin\lambda \\ \sin\phi \end{bmatrix}, \quad (32)$$

$$\left. \begin{aligned} \lambda &= \tan^{-1}\left(\frac{y}{x}\right) \\ \phi &= \sin^{-1}\left(\frac{z}{v}\right) \end{aligned} \right\} (33)$$

$$d\lambda = \frac{\partial\lambda}{\partial x} dx + \frac{\partial\lambda}{\partial y} dy = \frac{1}{x^2+y^2} (x dy - y dx), \quad (34)$$

$$d\phi = \frac{dz}{v \cos\phi}, \quad (35)$$

where  $v$  is considered constant. Introducing (31) into

(34) and (35) (noting that  $\lim_{z \rightarrow 0} \frac{\tan\phi}{z} = \lim_{\phi \rightarrow 0} \frac{1}{v(1-e^2)} = \frac{a}{b^2}$ ),

$$d\lambda = \omega_z t - \frac{zt}{x^2+y^2} (x\omega_x + y\omega_y), \quad (36)$$

$$d\phi = \frac{\tan\phi}{z} (y\omega_x - x\omega_y) t. \quad (37)$$

In Eqs. (36) and (37),  $t$  represents the interval of time in years from the epoch (time at which positions were assumed to be fixed) to the time of observation. The quantities  $\omega_i$  are obtained from adopted values of the absolute plate motions which are prescribed here in Appendix A.

Note that  $\frac{z}{x} = \tan\phi \sec\lambda$ ,  $\frac{z}{y} = \tan\phi \csc\lambda$ ,  $\cos\lambda = \frac{x}{(x^2+y^2)^{\frac{1}{2}}}$ ,  $\sin\lambda = \frac{y}{(x^2+y^2)^{\frac{1}{2}}}$ . From Eq. (36) and these,

$$\begin{aligned}\Delta\lambda &= \left[ \omega_z - z \cos\lambda \sin\lambda \left( \frac{\omega_x}{Y} + \frac{\omega_y}{X} \right) \right] t \\ &= \left[ \omega_z - \tan\phi (\omega_x \cos\lambda + \omega_y \sin\lambda) \right] t .\end{aligned}\quad (38)$$

In a like manner Eq. (37) can be written as

$$\Delta\phi = (\omega_x \sin\lambda - \omega_y \cos\lambda) t . \quad (39)$$

#### 2.4 Complex Parameters for Excitation Functions

The various geophysical effects upon the Earth's motion will be treated in terms of excitation functions. They are most simply treated in complex form. All forms of  $\Psi$  in the following are complex:

$$\Psi = \Psi^C \cos\sigma t + \Psi^S \sin\sigma t = \Psi^+ e^{i\sigma t} + \Psi^- e^{-i\sigma t} \quad (40)$$

$$\Psi = |\Psi^+| e^{i(\sigma t + \lambda^+)} + |\Psi^-| e^{-i(\sigma t - \lambda^-)} \quad (41)$$

$$\Psi^+ = (\arg \Psi^+) \quad \Psi^- = (\arg \Psi^-) \quad (42)$$

$$\Psi^C = \Psi^+ + \Psi^- \quad \Psi^S = i(\Psi^+ - \Psi^-) \quad (43)$$

$$\Psi^+ = \frac{1}{2}(\Psi^C - i\Psi^S) \quad \Psi^- = \frac{1}{2}(\Psi^C + i\Psi^S) \quad (44)$$

$$f = \frac{2|\Psi^-|}{|\Psi^+| + |\Psi^-|} \quad (\text{ellipticity or flattening}) \quad (45)$$

The major axis lies in east longitude  $\frac{1}{2}(\lambda^+ + \lambda^-)$  and has a magnitude  $|\Psi^+| + |\Psi^-|$ . It is occupied at such a time that  $\sigma t = \frac{1}{2}(\lambda^- - \lambda^+)$ .

## 2.5 Interpolation Formula

Interpolation of non-linear tabular data (e.g., ephemeris data) is by Gauss's forward interpolation formula (refer to Hildebrand (1956) for the general form) where the desired interpolated value  $f_{o+nw}$  is given by

$$f_{o+nw} = f_o + n \left\{ \Delta_1 + \frac{n-1}{2} \left\{ \Delta_2 + \frac{n+1}{3} \left\{ \Delta_3 + \frac{n-2}{4} \left\{ \Delta_4 + \frac{n+2}{5} \left\{ \Delta_5 \right\} \right\} \right\} \right\} \right\} , \quad (46)$$

where:

$$\begin{aligned} \Delta_1 &= f_1 - f_0 \\ \Delta_2 &= f_1 - 2f_0 + f_{-1} \\ \Delta_3 &= f_2 - 3f_1 + 3f_0 - f_{-1} \\ \Delta_4 &= f_2 - 4f_1 + 6f_0 - 4f_{-1} + f_{-2} \\ \Delta_5 &= f_3 - 5f_2 + 10f_1 - 10f_0 + 5f_{-1} - f_{-2} , \end{aligned}$$

and the subscripts are obtained from the Julian dates,

$$\text{J.D. Eph.} - \text{J.D. Obs.} = \text{Subscript.}$$

## 2.6 Spherical Harmonics

The Legendre functions for the spherical harmonics used in the EOM may be any one of four types: the regular form denoted by  $P_n$  or  $P_n^m$  (See Heiskanen and Moritz (1967)); an alternative form denoted by  $p_n$  or  $p_n^m$  (See Jeffreys and Jeffreys (1962)); a partially normalized form denoted by  $\bar{P}_n$  or  $\bar{P}_n^m$  (See Schmidt (1964)), and a fully normalized form denoted by  $\bar{P}'_n$  or  $\bar{P}'_n^m$  (See Heiskanen and Moritz 1967)). These different forms are related as follows:



$$P_n = P_n \quad (47)$$

$$P_n^m = \frac{(n-m)!}{n!} P_n^m \quad (48)$$

$$\bar{P}_n = P_n \quad (49)$$

$$\bar{P}_n^m = \left( \frac{2(n-m)!}{(n+m)!} \right)^{\frac{1}{2}} P_n^m \quad (50)$$

$$\bar{P}'_n = (2n+1)^{\frac{1}{2}} P_n \quad (51)$$

$$\bar{P}'_n{}^m = \left[ 2(2n+1) \frac{(n-m)!}{(n+m)!} \right]^{\frac{1}{2}} P_n^m \quad (52)$$

The Legendre expression  $P_n^m$  can be calculated using the equation (modified from Munk and MacDonald (1960)),

$$P_n^m = 2^{-n} n! (n+m)! (1-t^2)^{m/2} \sum_{r=0}^{n-m} \frac{(t-1)^{n-m-r} (t+1)^r}{(m+r)! (n-r)! (n-m-r)! r!} \quad (53)$$

where  $t = \sin \phi$ .

## 2.7 The Normal Potential<sup>10</sup>

The normal potential can be expressed using only zonal harmonics because of the rotational symmetry. The potential series is of the form (where  $\mu = \sin \phi$ ),

$$V = \frac{GM}{r} + A \frac{P_2(\mu)}{r^3} + A \frac{P_4(\mu)}{r^5} + \dots \quad (54)$$

$$A_{2n} = (-1)^n \frac{kME^{2n}}{2n+1} \left( 1 - \frac{2n}{2n+3} \frac{me'}{3q_0} \right) \quad (55)$$

$$E = (a^2 - b^2)^{\frac{1}{2}} = ea = e'b \quad (56)$$

$$q_0 = 2 \left( \frac{1}{3 \cdot 5} e'^3 - \frac{2}{5 \cdot 7} e'^5 + \frac{3}{7 \cdot 9} e'^7 - \dots \right) \quad (57)$$

---

<sup>10</sup> Source is Heiskanen and Moritz (1967).

Eq. (55) can also be written as

$$A_{2n} = (-1)^n \frac{3GME^{2n}}{(2n+1)(2n+3)} \left(1 - n + 5n \frac{C-A}{ME^2}\right) . \quad (58)$$

If the potential  $V$  is written in the form,

$$\begin{aligned} V &= \frac{GM}{r} \left[ 1 - J_2 \left(\frac{a}{r}\right)^2 P_2(\mu) - J_4 \left(\frac{a}{r}\right)^4 P_4(\mu) - \dots \right] \\ &= \frac{GM}{r} \left[ 1 - \sum_{n=1}^{\infty} J_{2n} \left(\frac{a}{r}\right)^{2n} P_{2n}(\mu) \right] , \end{aligned} \quad (59)$$

then the  $J$  (noting  $A_n = -GMa^n J_n$ ) are given by

$$J_{2n} = (-1)^{n+1} \frac{3e^{2n}}{(2n+1)(2n+3)} \left(1 - n + 5n \frac{C-A}{ME^2}\right) . \quad (60)$$

From the general form of Eq. (54),

$$V = \sum_{n=0}^{\infty} \sum_{m=0}^n \left[ A_n^m \frac{R_n^m(\theta, \lambda)}{r^{n+1}} + B_n^m \frac{S_n^m(\theta, \lambda)}{r^{n+1}} \right] , \quad (61)$$

$$\left. \begin{aligned} A_n &= G \int r'^n P_n(\mu') dM , \\ A_n^m &= 2 \frac{(n-m)!}{(n+m)!} G \int r'^n R_n^m(\theta', \lambda') dM , \\ B_n^m &= 2 \frac{(n-m)!}{(n+m)!} G \int r'^n S_n^m(\theta', \lambda') dM . \end{aligned} \right\} (62)$$

The solid harmonics  $r^n R_n^m$  and  $r^n S_n^m$  are simply homogeneous polynomials in  $x$ ,  $y$  and  $z$ . For example,

$$\begin{aligned} r^2 S_2^2 &= 3r^2 \sin^2 \theta \sin 2\lambda = 6r^2 \sin^2 \theta \sin \lambda \cos \lambda = 6(r \sin \theta \cos \lambda)(r \sin \theta \sin \lambda) , \\ &= 6xy . \end{aligned}$$

The moments of inertia with respect to the  $x, y, z$  axes are

$$\left. \begin{aligned} A &= \int (y'^2 + z'^2) dM, \\ B &= \int (z'^2 + x'^2) dM, \\ C &= \int (x'^2 + y'^2) dM, \\ D &= \int x'y' dM. \end{aligned} \right\} (63)$$

From Eqs. (62) and (63), setting  $A=B$ ,

$$\begin{aligned} A_0 &= GM & A_1 &= A_1^1 = B_1^1 = A_2^1 = B_2^1 = A_2^2 = 0, \\ A_2 &= G(A - C), & B_2^2 &= \frac{1}{2}GD \end{aligned} \quad (64)$$

(Note that  $GM$  for the Earth is here taken as  $3.98603 \times 10^{14}$  MKS.)

The gravity formula in closed form is

$$\gamma = \frac{GM}{a(a^2 \sin^2 \beta + b^2 \cos^2 \beta)^{\frac{3}{2}}} \left[ \left(1 + \frac{m}{3} \frac{e'q'_0}{q_0}\right) \sin^2 \beta + \left(1 - m - \frac{m}{6} \frac{e'q'_0}{q_0}\right) \cos^2 \beta \right]. \quad (65)$$

At the equator ( $\beta=0$ ),

$$\gamma_a = \frac{GM}{ab} \left(1 - m - \frac{m}{6} \frac{e'q'_0}{q_0}\right). \quad (66)$$

At the poles ( $\beta = \pm 90^\circ$ ),

$$\gamma_b = \frac{GM}{a^2} \left(1 + \frac{m}{3} \frac{e'q'_0}{q_0}\right). \quad (67)$$

Note that  $q_0$  is given by Eq. (57). For  $q'_0$ ,

$$q'_0 = 6 \left( \frac{1}{3 \cdot 5} e'^2 - \frac{1}{5 \cdot 7} e'^4 + \frac{1}{7 \cdot 9} e'^6 - \dots \right), \quad (68)$$

$$m = \frac{\omega^2 a^2 b}{GM}$$

With  $f = \frac{a-b}{a}$ ,  $f^* = \frac{\gamma_b - \gamma_a}{\gamma_a}$ , the rigorous form of Clairaut's formula is

$$f + f^* = \frac{\omega^2 b}{\gamma_a} \left( 1 + \frac{e' q'_0}{2q_0} \right) \quad (69)$$

The gravity formula (65) can be written in series form as

$$\gamma = \gamma_a \left[ 1 + \left( -f + \frac{5}{2}m + \frac{1}{2}f^2 - \frac{26}{7}fm + \frac{15}{4}m^2 \right) \sin^2 \phi + \left( -\frac{1}{2}f^2 + \frac{5}{2}fm \right) \sin^4 \phi \right], \quad (70)$$

or

$$\gamma = \gamma_a (1 + f_2 \sin^2 \phi + f_4 \sin^4 \phi) \quad , \quad (70')$$

with

$$\left. \begin{aligned} f_2 &= -f + \frac{5}{2}m + \frac{1}{2}f^2 - \frac{26}{7}fm + \frac{15}{4}m^2 \quad , \\ f_4 &= -\frac{1}{2}f^2 + \frac{5}{2}fm \quad . \end{aligned} \right\} (71)$$

Eq. (70') can be written as

$$\gamma = \gamma_a (1 + f^* \sin^2 \phi - \frac{1}{4}f_4 \sin^2 2\phi) \quad , \quad (70'')$$

where  $f^*$  is known as the gravity flattening.

The normal gravity at elevation  $H$  above the ellipsoid is

$$\begin{aligned} \gamma_H &= \gamma + \frac{\partial \gamma}{\partial H} H + \frac{1}{2} \frac{\partial^2 \gamma}{\partial H^2} H^2 + \dots \quad , \\ &= \gamma \left[ 1 - \frac{2}{a} (1 + f + m - 2f \sin^2 \phi) H + \frac{3}{a^2} H^2 \right] \quad . \end{aligned} \quad (72)$$

## 2.8 Love Numbers and Applications

Love numbers may, in theory, be taken to any degree  $n$ . The measure of application is the nature of the disturbing potential. Since the Earth is effectively subject only to a second-degree potential, Love numbers of consideration are  $h$ ,  $k$  and  $\ell$ . The matter has been studied by a number of researchers,<sup>11</sup> but the most detailed investigation appears to be that of Takeuchi (1950). Love number determinations are made from observations of seismic phenomena, and tidal induced tilts, variations of gravity and position. The  $k$  coefficient can also be determined from observations of polar wobble period. Estimates are subject to contributions of Earth's core, mantle and yielding oceans. Since Love numbers are indicators of elastic characteristics, values should vary randomly for different locations; in addition, a latitude dependency has been suggested by Kaula (1969) based on analysis of published data. There is, however, no strong reason to systematically characterize variabilities in Love numbers. and, for the purposes of the EOM, values of  $h=0.59$ ,  $k=0.29$  and  $\ell=0.07$  have been adopted.

The Chandler period is given by Kaula (1968) as

$$T = \frac{A+k\omega^2 a^5/(3G)}{C-A-k\omega^2 a^5/(3G)} \quad (73)$$

---

<sup>11</sup> These include Jeffreys (1970), Kaula (1968), Kozai (1965), Lamb (1917), Love (1911), Longman (1966), Melchior (1966), Munk and MacDonald (1960), Nishimuri (1950), Shida and Matsuyama (1912), Takeuchi (1966), Vicente (1961).

The products of inertia due to rotational deformation (Munk and MacDonald (1960)) are

$$C_i^j = I\delta_i^j + \frac{ka^5}{3G}(\omega_i\omega^j - \frac{1}{3}\omega^2\delta_i^j) \quad , \quad (74)$$

where  $I = \frac{1}{3}(C_1^1 + C_2^2 + C_3^3)$  is the Earth's inertia,  $a$  is the mean radius and  $G$  is the Earth's mass. Note that the effect of elasticity in (73) is to lengthen the period and in (74) to induce products of inertia.

The luni-solar potential is effectively given (See Section 2.9) by

$$W_2 = -\frac{GM}{2} \frac{R^2}{r^3} (1 - 3 \cos^2 \zeta) \quad . \quad (75)$$

For a non-deformable Earth, the horizontal components of the luni-solar force are

$$\left. \begin{aligned} f_\theta &= \frac{1}{R} \frac{\partial W_2}{\partial \theta} \quad , \\ f_\lambda &= \frac{1}{R \sin \theta} \frac{\partial W_2}{\partial \lambda} \quad , \end{aligned} \right\} (76)$$

where  $\theta$  is the colatitude and  $\lambda$  the east longitude. The corresponding vertical deflections are

$$\left. \begin{aligned} \xi' &= \frac{f_\theta}{g} \quad , \\ \eta' &= \frac{f_\lambda}{g} \quad , \end{aligned} \right\} (77)$$

where  $\xi'$  is the meridian and  $\eta'$  the prime vertical components,

respectively. The spatial displacements for an elastic Earth are

$$\left. \begin{aligned} v &= \frac{\ell}{g} \frac{\partial W_2}{\partial \theta} , \\ w &= \frac{\ell}{g \sin \theta} \frac{\partial W_2}{\partial \lambda} , \end{aligned} \right\} (78)$$

in the meridian and prime vertical directions, respectively. The total disturbing potential is  $(1+k)W_2$  and a static oceanic tide should have an effective height  $(1+k)W_2/g$ ; a tide gage, however, indicates variations between ocean tide and crustal motion, the latter being given by  $\frac{h}{g}W_2$ . An observed tidal amplitude will, therefore, be the difference between these two, or

$$(1+h)\frac{W_2}{g} - \frac{h}{g}W_2 = (1+k-h)\frac{W_2}{g} = \gamma\frac{W_2}{g} . \quad (79)$$

Given  $V_0$  as the initial Earth's potential, gravitational acceleration is

$$g_0 = \frac{GM}{R^2} = - \frac{\partial V_0}{\partial R} .$$

But the Earth's potential, deformed by the luni-solar action, is

$$V' = W_2 + W_2' + \frac{\partial V_0}{\partial R} + V_0 ,$$

and the variation of  $g$  will be the derivative with respect to  $R$  of the additional potential,

$$\Delta g = g_0 - g_1 = \frac{\partial}{\partial R}(W_2 + W_2' + \frac{\partial V_0}{\partial R}) \quad (80)$$

Here  $W_2'$  represents the additional potential due to the Earth's deformation (in the form  $S_2/R^3$ ) while

$$\beta = \frac{h}{g} W_2 \quad (81)$$

Performing the indicated differentiations in (80),

$$\Delta g = 2 \frac{W_2}{R} (1+h-\frac{3}{2}k) = (1+h-\frac{3}{2}k) \frac{\partial W_2}{\partial R} = \frac{\partial W_2}{\partial R} \quad (82)$$

The angle between the normal and the deformed surface is of interest. The equation for the latter is

$$\rho = R + h \frac{W_2}{g} \quad (83)$$

The flattening of this surface can be calculated by relating its equation with that of an ellipsoid of revolution with mean radius  $a$  and ellipticity  $e$ ; i.e.,

$$\rho' = R \left[ 1 + \frac{e^2}{2} \left( \frac{2}{3} - \cos^2 \theta \right) \right] \quad (84)$$

where  $\theta$  is the colatitude. From (84) and the value of  $g$  for a homogeneous sphere of radius  $R$  and mean density  $d$ , or  $g = \frac{4}{3} \pi G d R$ , the deformed eccentricity is given by

$$e^2 = 3 \frac{G h R M}{g r^3} \quad (85)$$

The angle  $\alpha$  of the normal to this ellipsoid with the unperturbed ellipsoidal normal is



$$\begin{aligned}\alpha &= -\frac{1}{\rho} \frac{\partial \rho}{\partial \theta} = \frac{e^2}{2} \sin 2\theta \\ &= \frac{3}{2} \frac{GMhR}{gr^3} \sin 2\theta = -\frac{1}{g} \frac{h}{R} \frac{\partial W_2}{\partial \theta} .\end{aligned}$$

This quantity added to the pendulum deviation,  $\frac{1+k}{Rg} \frac{\partial W_2}{\partial \theta}$ , gives the observed effect as

$$\frac{1+k-h}{Rg} \frac{\partial W_2}{\partial \theta} = \frac{\gamma}{Rg} \frac{\partial W_2}{\partial \theta} . \quad (86)$$

The crust deformation is in the same direction as the force and thus is partly compensating. The factor  $\gamma$  is the ratio of the observed deflection amplitude to the calculated theoretical static amplitude.

Deflections cause a variance in astronomic coordinates. The deflection is not related to the crust but to the direction of the Earth's rotation axis in inertial space. Eqs. (77) and (78) express the respective components of vertical deflection and surface deformation. The deformation will also cause a supplementary disturbing potential  $kW_2$  which must be added to  $W_2$  in the expressions. Finally, the deflection of the vertical with respect to the Earth's axis will be

$$\left. \begin{aligned}\xi &= (1+k-\ell) \frac{1}{Rg} \frac{\partial W_2}{\partial \theta} = \frac{\Lambda}{Rg} \frac{\partial W_2}{\partial \theta} , \\ \eta &= (1+k-\ell) \frac{1}{Rg \sin \theta} \frac{\partial W_2}{\partial \lambda} = \frac{\Lambda}{Rg \sin \theta} \frac{\partial W_2}{\partial \lambda} .\end{aligned} \right\} (87)$$

Figure 2.5 Tidal Force

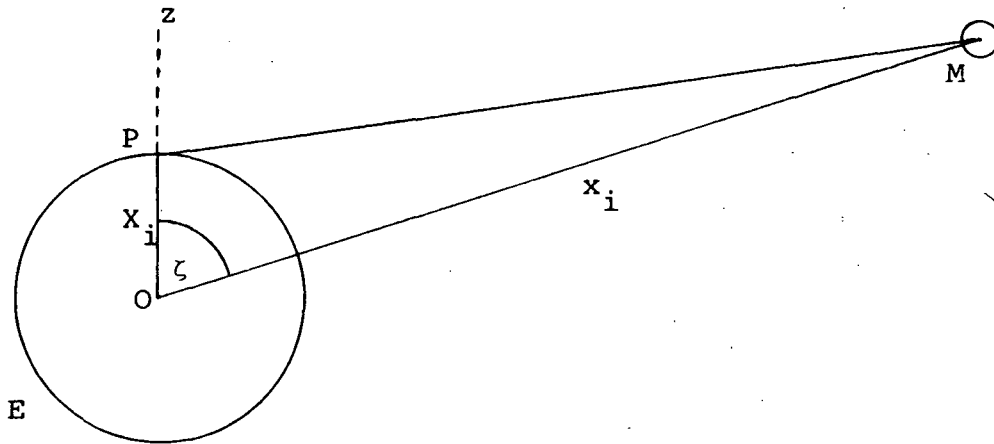

### 2.9 Tidal Force

The tidal force acting on a unit mass at point P due to the attraction of an extraterrestrial mass M is

$$F_i = GM \left[ \frac{x_i - X_i}{|x_i - X_i|^3} - \frac{x_i}{|x_i|^3} \right], \quad (88)$$

where M is the mass of the attracting body. Expanding the denominator of the first term and assuming  $|X_i| = R \ll |x_i| = r$ ,

$$F_i = -\frac{GM}{r^3} (X_i - \frac{3x_j x^j}{r^2} x_i) = -\frac{GM}{r^3} (X_i - \frac{3R \cos \zeta}{r} x_i) . \quad (89)$$

Eq. (89) can be resolved into its horizontal and vertical components which are

$$F(h) = \frac{3}{2} GM \frac{R}{r^3} \sin 2\zeta, \quad (90)$$

$$F(v) = GM \frac{R}{r^3} (1 - 3 \cos^2 \zeta) . \quad (91)$$

It can be seen that Eqs. (90) and (91) can be derived from the potential,

$$W_2 = \frac{GM}{2} \frac{R^2}{r^3} (3 \cos^2 \zeta - 1) \quad , \quad (92)$$

by taking the derivatives,

$$F(h) = - \frac{1}{R} \frac{\partial W_2}{\partial \zeta}$$

and

$$F(v) = - \frac{\partial W_2}{\partial R} \quad .$$

## 2.10 Precession and Nutation

### 2.10.1 Louville Equation:

The Eulerian equations of motion in a coordinate system  $x_i$  rotating with angular velocity  $\omega_i$  relative to coordinates  $X_i$  fixed in inertial space are

$$N_i = \dot{H}_i + \epsilon_{ijk} \omega^j H^k \quad . \quad (93)$$

$N_i$  and  $H_i$  are torque and angular momentum vectors, respectively, and  $\epsilon_{ijk}$  is the completely unsymmetric permutation tensor. Following Munk and MacDonald (1960), we separate the angular momentum into two parts:

$$H_i = C_{ij}(t) \omega^j + h_i(t) \quad (94)$$

where

$$C_i^j = \int \rho (x_k x^k \delta_i^j - x_i x^j) dV \quad (95)$$

is the inertial tensor,  $\rho$  is the density and  $\delta_i^j$  is the Kronecker delta. The second right-hand term of (94) denotes a relative angular momentum,

$$h_i = \int \rho \varepsilon_{ijk} x^j u^k dV , \quad (96)$$

due to the velocity  $u_i$  relative to the  $x_i$  system. Introducing (95) and (96) into (93) we obtain

$$N_i = \frac{d}{dt} (C_{ij} \omega^j + h_i) + \varepsilon_{ijk} \omega^j (C^{k\ell} \omega_\ell + h^k) , \quad (97)$$

the Liouville equation.

#### 2.10.2 Dynamic Equations for the Precession:

In terms of rectangular coordinates  $x_i'$  of  $M'$  (the external attracting mass) in the CIO coordinate system (with BIH prime meridian), the couple,  $N_i$ , exerted on the Earth is

$$N_i = \varepsilon_{ijk} x^j \nabla^k U = - \varepsilon_{ijk} x^j \nabla^k U . \quad (98)$$

Introducing these into (97),

$$\dot{C}_{ij} \omega^j + C_{ij} \dot{\omega}^j + h_i + \varepsilon_{ijk} \omega^j (C^{k\ell} \omega_\ell + h^k) = \varepsilon_{ijk} x^j \nabla^k U . \quad (99)$$

Assume, for the moment, that the relative angular momenta,  $h_i$ , are included in the angular momenta,  $C_{ij} \omega^j$ , and these are constant.

Then (99) becomes

$$C_{ij} \dot{\omega}^j + \varepsilon_{ijk} \omega^j C^{k\ell} \omega_\ell = - \varepsilon_{ijk} x^j \nabla^k U . \quad (100)$$

We next make the temporary assumption that there are no products

of inertia. Then setting  $C_{11}=A$ ,  $C_{22}=B$ ,  $C_{33}=C$ ,  $C_{ij}=0$ ,  $i \neq j$ , and expanding (100),

$$\begin{aligned}\dot{\omega}_1 + \frac{C-B}{A}\omega_2\omega_3 &= \frac{1}{A}(x'_3 \frac{\partial U}{\partial x'_2} - x'_2 \frac{\partial U}{\partial x'_3}) , \\ \dot{\omega}_2 - \frac{C-A}{B}\omega_1\omega_3 &= \frac{1}{B}(x'_1 \frac{\partial U}{\partial x'_3} - x'_3 \frac{\partial U}{\partial x'_1}) , \\ \dot{\omega}_3 + \frac{B-A}{C}\omega_1\omega_2 &= \frac{1}{C}(x'_2 \frac{\partial U}{\partial x'_1} - x'_1 \frac{\partial U}{\partial x'_2}) .\end{aligned}\tag{101}$$

The right-hand terms of (101) can be written in terms of Euler angles and we obtain

$$\begin{aligned}\dot{\omega}_1 + \frac{C-B}{A}\omega_2\omega_3 &= \frac{1}{A} \frac{\sin\phi}{\sin\theta} (\cos\theta \frac{\partial U}{\partial \phi} - \frac{\partial U}{\partial \psi}) - \cos\phi \frac{\partial U}{\partial \theta} , \\ \dot{\omega}_2 - \frac{C-A}{B}\omega_1\omega_3 &= \frac{1}{B} \frac{\cos\phi}{\sin\theta} (\cos\theta \frac{\partial U}{\partial \phi} - \frac{\partial U}{\partial \psi}) + \sin\phi \frac{\partial U}{\partial \theta} , \\ \dot{\omega}_3 + \frac{B-A}{C}\omega_1\omega_2 &= \frac{1}{C} \frac{\partial U}{\partial \phi} .\end{aligned}\tag{102}$$

We can set  $A=B$ , whence  $\partial U/\partial \phi=0$  because of the symmetry, and

$$\begin{aligned}\dot{\omega}_1 + \frac{C-A}{A}\omega_2\omega_3 &= - \frac{\sin\phi}{A \sin\theta} \frac{\partial U}{\partial \psi} - \frac{\cos\phi}{A} \frac{\partial U}{\partial \theta} , \\ \dot{\omega}_2 - \frac{C-A}{A}\omega_1\omega_3 &= - \frac{\cos\phi}{A \sin\theta} \frac{\partial U}{\partial \psi} + \frac{\sin\phi}{A} \frac{\partial U}{\partial \theta} ,\end{aligned}\tag{103}$$

$$\omega_3 = \text{constant}.$$

### 2.10.3 Precession and Nutation for a Rigid Earth:

The complexity of the problem indicates that the best solution would be to treat the precession using a rigid Earth and making such corrections as are necessary for the elastic

yielding in a separate process. This provides a highly accurate representation and will afford firm bases for correcting for departures from rigidity. We follow to some extent the work of Woolard (1953).

The first assumption is that there are no products of inertia; secondly, that the moments about the two minor axes of figure are equal. Eq. (103) is thus applicable. Differentiating the first two of Eq. (3), we eventually obtain

$$\ddot{\theta} = - \frac{1}{C\omega_3 \sin\theta} \frac{\partial U}{\partial \psi} + \frac{A}{C\omega_3} \frac{d}{dt}(\dot{\psi} \sin\theta) + \frac{A}{C\omega_3} \dot{\psi} \ddot{\theta} \cos\theta \quad (104)$$

and

$$\dot{\psi} = \frac{1}{C\omega_3 \sin\theta} \frac{\partial U}{\partial \theta} - \frac{A}{C\omega_3 \sin\theta} \ddot{\theta} + \frac{A}{C\omega_3} \dot{\psi}^2 \cos\theta \quad (105)$$

Eqs. (104) and (105) can be utilized in an approximate form by considering only their first right-hand terms. This gives a close approximation of the axis of figure. Small additions to account for the effect of the unused terms are appreciable but can be easily obtained by an iterative solution, the convergence being quite rapid.

The force function  $U$  for the gravitational action exerted on the Earth by an external rigid body with mass  $M'$  and principal moments of inertia  $A', B', C'$ , is

$$U = G \int dm' \frac{dm'}{\rho'} = G \frac{MM'}{r} + GM' \frac{A+B+C-3I_r}{2r^3} + GM' \frac{A'+B'+C'-3I'_r}{2r^3} + \dots,$$

where  $I_r$  and  $I'_r$  are moments of inertia of Earth and  $M'$ , respectively, about the line  $r$  joining the C.M.s of the two bodies.

In the case of luni-solar forces, effects of extended terms and of the A',B',C' inequalities are so small we can take  $S'+B'+C'=3I_r$  and

$$U = GM' \left( \frac{M}{r} + \frac{A+B+C-3I_r}{2r^3} \right) \quad (106)$$

Setting the Earth's coordinate axes along the principal inertial axes and denoting the coordinates of the C.M. of mass of M', in this system, by  $x'_i$ , we have with  $x_i x_i = r^2$ ,

$$I_r = \frac{1}{r^2} (Ax_1'^2 + Bx_2'^2 + Cx_3'^2) \quad (107)$$

Since  $r$  does not depend upon the orientation of the Earth's principal axes, it is independent of the Euler angles with respect to which  $U$  is differentiated in the equations of motion; therefore, all terms in  $U$  which depend only upon  $r$  and constants can be disregarded. Setting  $A=B$  in (106), we obtain

$$U = - 3GM' \frac{C-A}{2r^5} x_3'^2 \quad (108)$$

In terms of the  $X_i$  system, the coordinates of the disturbing body are

$$\left. \begin{aligned} X_1 &= r \cos\beta_0 \cos\lambda_0 \\ X_2 &= r \cos\beta_0 \sin\lambda_0 \\ X_3 &= r \sin\beta_0 \end{aligned} \right\} (109)$$

where  $\beta_0$  and  $\lambda_0$  are the latitude and longitude, respectively, of M' referred to the fixed mean equinox and ecliptic of specified epoch. From Eqs. (4) and (109),

$$x'_3 = r(\sin\theta\cos\beta_0\sin(\lambda_0-\psi) + \cos\theta\sin\beta_0) \quad (110)$$

Introducing (110) into (108), differentiating, and introducing into (104) and (105), as appropriate, (utilizing only the first right-hand terms of these latter two) we obtain

$$\dot{\theta} = -3GM' \frac{C-A}{r^3 C\omega_3} \{ \sin\theta\cos\beta_0\sin(\lambda_0-\psi) + \cos\theta\sin\beta_0 \} \cos\beta_0 \cos(\lambda_0-\psi) \quad (111)$$

and

$$\dot{\psi} = -3GM' \frac{C-A}{r^3 C\omega_3} \{ \sin\theta\cos\beta_0\sin(\lambda_0-\psi) + \cos\theta\sin\beta_0 \} \{ \cot\theta\cos\beta_0\sin(\lambda_0-\psi) - \sin\beta_0 \} \quad (112)$$

The coordinates  $\beta_0, \lambda_0$ , of the Sun and Moon, referred to a fixed mean equinox and ecliptic of some epoch are obtained from solar and lunar theories; but these theories give the coordinate expressions referred to a moving mean equinox and ecliptic of date, and it is therefore necessary to transform Eqs. (111) and (112) to these coordinates. Through an appropriate process (refer to Woolard (1953)), the coordinate relationships between  $\beta_0, \lambda_0$  and  $\beta, \lambda$  (the latter being the coordinates of date) are



Figure 2.6 Ecliptics and Equinoxes of Epoch and Date

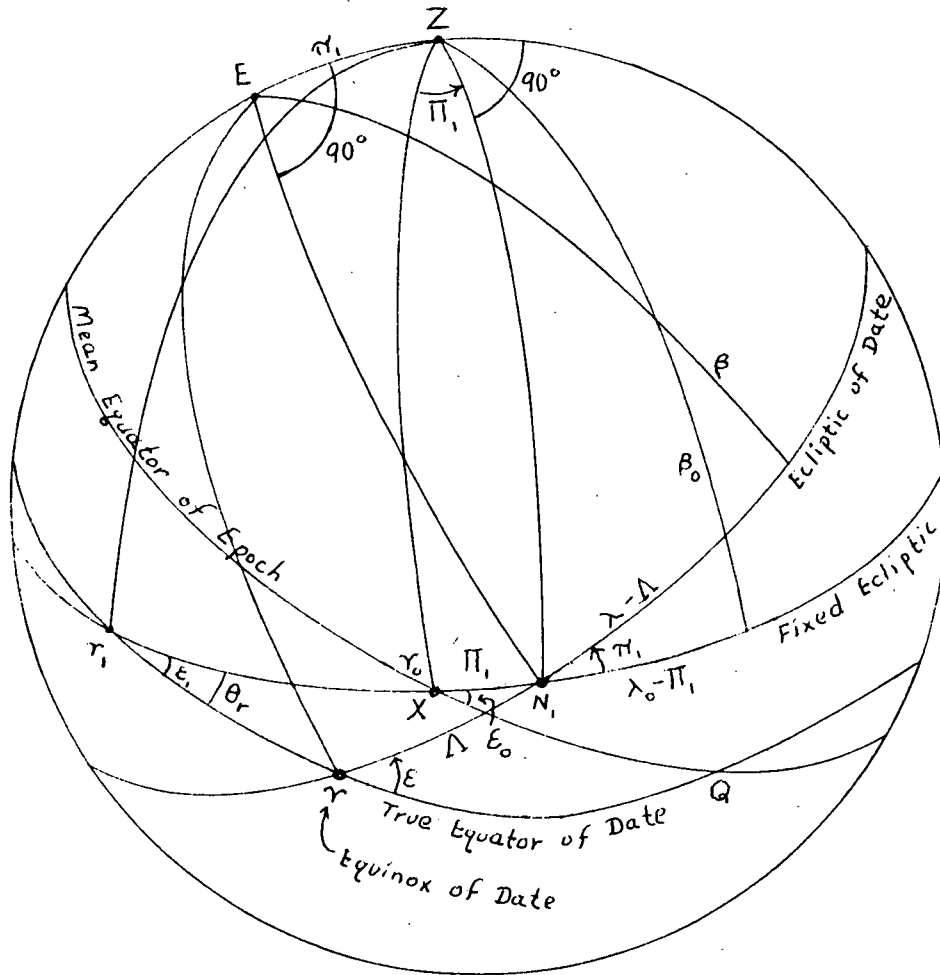

$$\begin{aligned}
 \cos\beta_0 \cos(\lambda_0 - \psi) &= \cos\beta \{ \cos(\lambda - \Lambda + \Pi_1 - \psi) + 2\sin(\lambda - \Lambda)\sin(\Pi_1 - \psi)\sin^2 \frac{1}{2}\pi_1 \} \\
 &\quad + \sin\beta \sin\pi_1 \sin(\Pi_1 - \psi) \quad , \\
 \cos\beta_0 \sin(\lambda_0 - \psi) &= \cos\beta \{ \sin(\lambda - \Lambda + \Pi_1 - \psi) - 2\sin(\lambda - \Lambda)\cos(\Pi_1 - \psi)\sin^2 \frac{1}{2}\pi_1 \} \\
 &\quad - \sin\beta \sin\pi_1 \cos(\Pi_1 - \psi) \quad , \\
 \sin\beta_0 &= \cos\beta \sin(\lambda - \Lambda)\sin\pi_1 + \sin\beta \cos\pi_1 \quad ,
 \end{aligned}
 \tag{113}$$

where the elements are defined in Figure 2.6.

An alternate and much more simple procedure<sup>12</sup> may be used in developing the quantities  $\beta_0, \lambda_0$  from  $\beta(t), \lambda(t)$  for Eqs. (111) and (112). We have, for an epoch of 1950.0,

$$\begin{aligned}
 T &= (\text{J.D.}_{(\text{obs})} - 2433282.5)/36525 \quad , \\
 \varepsilon_0 &= 23^\circ.445787 \quad , \\
 \varepsilon &= 23^\circ.445787 - 0^\circ.0130125T - 0^\circ.00000164T^2 \\
 &\quad + 0^\circ.00000050T^3 + \Delta\varepsilon \quad ,
 \end{aligned}$$

where  $\Delta\varepsilon$  is the nutation in the obliquity; then,

$$\begin{aligned}
 \delta &= \sin^{-1}(\cos\beta \sin\lambda \sin\varepsilon + \sin\beta \cos\varepsilon) \quad , \\
 \alpha &= \cos^{-1}(\cos\beta \cos\lambda / \cos\delta) \quad , \\
 \zeta_0 &= z - 0''.791T^2 - 0''.0013T^3 \quad , \\
 \theta &= -2004''.255T + 0''.426T^2 + 0''.0416T^3 \quad , \\
 q &= \sin\theta \{ \tan\delta + \cos(\alpha + \zeta_0) \tan \frac{1}{2}\theta \} \quad , \\
 \Delta\alpha - \mu &= \tan^{-1} \{ q \sin(\alpha + \zeta_0) / [1 - q \cos(\alpha + \zeta_0)] \} \quad , \\
 \alpha_0 &= \alpha + \Delta\alpha \quad , \\
 \delta_0 &= \delta + 2 \tan^{-1} \{ \tan \frac{1}{2}\theta \sec \frac{1}{2}(\Delta\alpha - \mu) \cos [(\alpha + \zeta_0) + \frac{1}{2}(\Delta\alpha - \mu)] \} \quad ,
 \end{aligned}$$

<sup>12</sup> See Am. Ephemer. and Naut. Alm., NHO, 1976, pp. 536 and 552.

$$z = -2304''.948T - 0''.302T^2 - 0''.0179T^3 ,$$

$$\mu = z + \zeta_0 ,$$

$$\beta_0 = \sin^{-1}(-\cos\delta_0 \sin\alpha_0 \sin\epsilon_0 + \sin\delta_0 \cos\epsilon_0) , \quad (114)$$

$$\lambda_0 = \cos^{-1}(\cos\delta_0 \cos\alpha_0 \sec\beta_0) . \quad (115)$$

A less rigorous transformation from  $\beta(t)$ ,  $\lambda(t)$  to  $\beta_0$ ,  $\lambda_0$  is obtained from the expressions,

$$\beta_0 \approx \beta + b \sin(\lambda+c) , \quad (116)$$

$$\lambda_0 \approx \lambda + a - b \cos(\lambda+c) \tan\beta , \quad (117)$$

where

$$a = -1^{\circ}.396319T - 0^{\circ}.000308T^2 ,$$

$$b = -0^{\circ}.013076T + 0^{\circ}.000010T^2 ,$$

$$c = 5^{\circ}.59258 - 1^{\circ}.15473T - 0^{\circ}.00015T^2 .$$

Setting

$$K = -3GM' \frac{C-A}{r^3 C \omega_3} ,$$

$$P = \sin\theta \cos\beta_0 \sin(\lambda_0 - \psi) + \cos\theta \sin\beta_0 ,$$

$$Q = \cos\beta_0 \cos(\lambda_0 - \psi) ,$$

$$R = \cos\beta_0 \sin(\lambda_0 - \psi) \cot\theta - \sin\beta_0 ,$$

} (118)

Eqs. (111) and (112) can be written as

$$\dot{\theta} = KPQ \quad , \quad (111')$$

$$\dot{\psi} = KPR \quad . \quad (112')$$

Noting that

$$\ddot{\psi} = K(\dot{P}R + P\dot{R}) \quad , \quad (119)$$

$$\left. \begin{aligned} \dot{P} &= KP\{Q\cos\theta\sin(\lambda_0 - \psi) - R\sin\theta\cos(\lambda_0 - \psi)\}\cos\beta_0 \\ &\quad - Q\sin\theta\sin\beta_0 \quad , \\ \dot{Q} &= KPR\cos\beta_0\sin(\lambda_0 - \psi) \quad , \\ \dot{R} &= -KP\{Q\sin(\lambda_0 - \psi) + \frac{1}{2}R\sin 2\theta\cos(\lambda_0 - \psi)\}\cos\beta_0\csc^2\theta \quad . \end{aligned} \right\} (120)$$

Introducing Eqs. (111'), (112'), (119) and (120) into Eqs. (104) and (105), we obtain the bases for iterative solutions of (104) and (105),

$$\underline{\dot{\theta}} = KPQ + \frac{AK}{C\omega_3}\{(\dot{P}R + P\dot{R})\sin\theta + 2KQRP^2\cos\theta\} \quad , \quad (121)$$

$$\underline{\dot{\psi}} = KPR - \frac{AK}{C\omega_3\sin}(\dot{P}Q + P\dot{Q} - \frac{1}{2}KP^2R^2\sin 2\theta) \quad , \quad (122)$$

where the underbars are introduced to discriminate from the provisional values  $\theta, \psi$ , used in forming the right-hand terms, which will be successively updated in the iteration process.

Final values of  $\theta(t)$  and  $\psi(t)$  are obtained by integrating updated  $\underline{\dot{\theta}}(t)$  and  $\underline{\dot{\psi}}(t)$  quantities. The remaining Euler angle,  $\phi$ , is obtained from the expression,

$$= \gamma_0 + \tau \quad , \quad (123)$$

where  $\gamma_0$  is the ephemeris value for the Julian date of the midnight preceding the first observation date, and  $\tau$  is given by

$$\tau = 360^{\circ}.98565 (\text{J.D. (obs)} - \text{J.D.}_0)$$

#### 2.10.4 Correction for a Deformable Earth:

The effects of the luni-solar force on a deformable Earth are considered in Section 2.15. Values which substantially compensate for the rigid Earth assumption made in this section are derived.

### 2.11 Plate Tectonics

Plate tectonics theory has been extensively developed over a relatively short period, with the investigative process being ultimately directed toward discovering a scientifically valid mechanism for the plate motions. Relative plate motions, manifested as continental drifts, are fully accepted phenomena and have been (for at least the ten largest plates) fairly well evaluated.<sup>13</sup> The matter of absolute motions; i.e., motion with respect to the fixed portion of the mantle, say, the asthenosphere, presents a more illusory problem, since there are no proven means for referencing to a fixed

---

<sup>13</sup> Refer to Chase (1972), LePichon (1968), Minster et al. (1974), Morgan (1968).

triad in the inner mantle. A number of authors<sup>14</sup> have presented theories for absolutely relating one or more plate motions to fixed interior references. The consensus links absolute motion determination with the plate driving mechanism, and most writers have tried to bring them together as a total system.

Plate boundaries are fairly well delineated by systematically tracing seismic activities. Maps, such as those described by Barazangi and Dorman (1969) provide indications of plate demarcations and directions of motion. Kaula (1975)<sup>15</sup> outlines the boundaries of thirteen plates in a system of great circle arcs. These plates and their boundaries were incorporated in the EOM. A fourteenth, the Caribbean, was added, with boundary based on Malfait and Dinkleman (1972).

A number of absolute plate motion systems were evaluated for application to the EOM. The system of choice was one of the models proposed by Solomon and Sleep (1974). The selected Model A fixed the absolute motion of one plate based on a general concept that there was a uniform drag beneath all plates. This simple model agreed remarkably well with more sophisticated ones (Morgan (1973), Minster et al. (1974)), whose velocities were calculated from the hypothesis of fixed

---

<sup>14</sup> These include Burke and Wilson (1972), Clague and Jarrard (1973), Duncan et al. (1972), Kaula (1975), Mckenzie et al. (1974), Minster et al. (1974), Sleep (1975), Solomon and Sleep (1974), Solomon et al. (1975), Turcotte (1975), Wilson (1965).

<sup>15</sup> Referred to by the author in a computing program. Program details and boundaries are on computing tape. (Refer to Section 4.10.)

hot spots, and there is no basis for a more involved system, with the present state of knowledge.<sup>16</sup> The absolute motions of the remaining plates were calculated from the relative motion data given by Solomon and Sleep (1974).

Plate parameters are the coordinates of the rotation pole, and the rotation rate or, more simply, only the components of the rotation vector. Plate names, identifying numbers and rotation parameters are given in Table 2.4. An example

Table 2.4 Tectonic Plate Parameters

Plate Number	Plate Name	Abbreviation	$\omega_i$ ( $10^{-7}$ deg/yr)		
			$\omega_x$	$\omega_y$	$\omega_z$
1	African	AFRC	1.3483	-2.4585	2.8415
2	Antarctic	ANTA	-0.2660	-0.4475	2.6859
3	Arabian	ARAB	4.8787	-1.0630	4.5355
4	Cocos	COCO	-7.3499	-15.2714	7.5398
5	Eurasian	EURA	-1.2936	-1.1125	-1.4502
6	Indian	INDI	5.4483	2.0823	4.4787
7	Nazca	NAZC	-2.2031	-4.6138	6.0178
8	North American	NOAM	0.1281	-1.7780	-0.3030
9	Pacific	PCFC	-1.2867	2.8497	-6.4968
10	South American	SOAM	0.1281	-1.7780	-0.3030
11	Bering	BERI	0.1281	-1.7780	-0.3030
12	Philippine	PHLP	3.2305	1.0976	-6.0047
13	Somali	SMLI	1.3483	-2.4585	2.8415
14	Caribbean	CARI	-0.4474	-0.2825	0.5532

<sup>16</sup> Any model can be readily introduced into the EOM by making the desired changes in the rotation parameters.

for updating plate parameters follows:

Given the absolute rotation pole parameters for the Pacific plate (PCFC) as  $\phi = -64^{\circ}.3$ ,  $\lambda = 114^{\circ}.3$ ,  $\omega = 7.21 \times 10^{-7}$  deg/hr; given the pole parameters of the African plate (AFRC) relative to PCFC (assumed fixed in motion) as  $\phi = 57^{\circ}.6$ ,  $\lambda = -63^{\circ}.6$ ,  $\omega = 11.06 \times 10^{-7}$  deg/hr; find the absolute rotational components of AFRC:

From Eq. (30),

$$\text{Absolute PCFC: } \omega_x = -1.2867, \quad \omega_y = 2.8497, \quad \omega_z = -6.4968.$$

$$\text{Relative AFRC: } \omega_x = 2.6350, \quad \omega_y = -5.3082, \quad \omega_z = 9.3383.$$

---

$$\omega_i(\text{PCFC}) + \omega_i(\text{AFRC}): \omega_x = 1.3483 \quad \omega_y = -2.4585 \quad \omega_z = 2.8415.$$

The inverse procedure (rotation components to pole parameters) is given by<sup>16</sup>

$$\begin{aligned} \omega &= \left| \omega_i \omega^i \right|^{1/2} \quad (\text{positive root, only}), \\ \phi &= \sin^{-1} \left( \frac{\omega_z}{\omega} \right), \\ \lambda &= \tan^{-1} \left( \frac{\omega_y}{\omega_x} \right) \end{aligned} \quad \left. \vphantom{\begin{aligned} \omega \\ \phi \\ \lambda \end{aligned}} \right\} (124).$$

The general boundaries of the plates are shown in Figure 2.7. A more exact plot is given on the map attachment to the computing materials (See Section 4.2.3). In most cases, identification of the appropriate plate for a station of given coordinates will be quite simple; however, when a station lies

---

<sup>16</sup> Note that, for all poles, latitudes are positive and longitudes are negative. When  $\omega_x$  is negative,  $|\lambda| > 90^{\circ}$ ; otherwise,  $|\lambda| < 90^{\circ}$ .



near a plate boundary, the boundary description may be too general, and a definite check must be made to identify the proper plate. For this reason, and because of the impracticability of mathematically delineating the highly irregular and often changing boundaries, it was decided to require a "hand-identification" process for all points; thus avoiding problems for critically located sites.

Figure 2.7 Tectonic Plate Boundaries

(Adapted from Solomon and Sleep (1974))

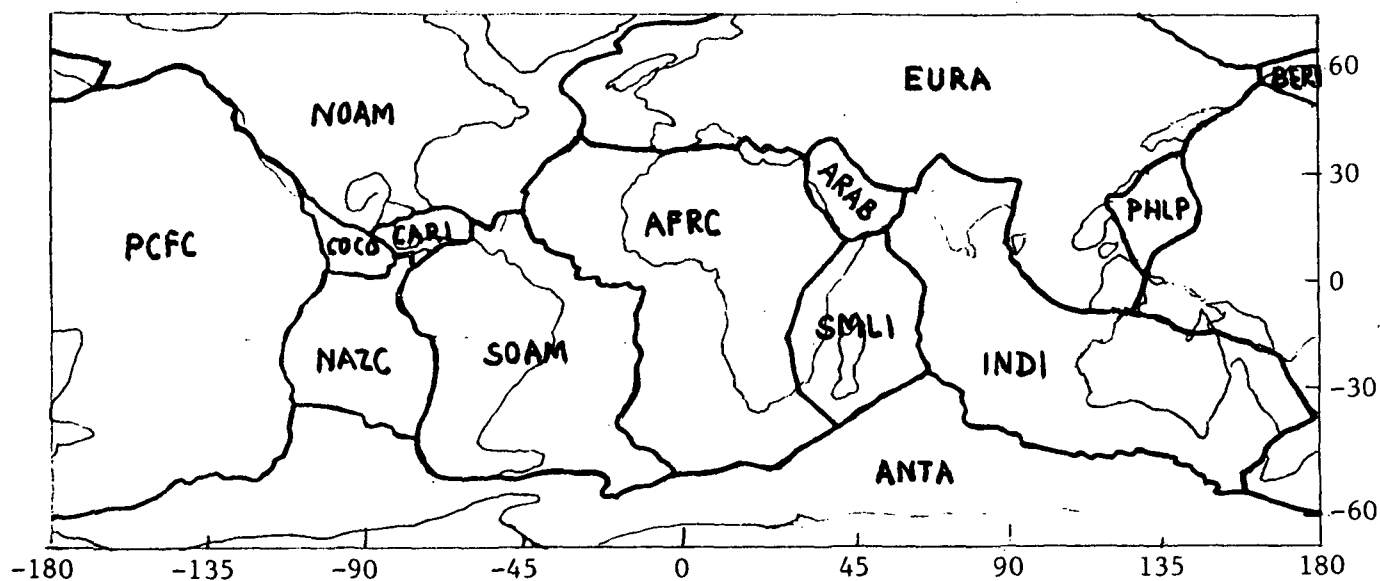

## 2.12 Atmospherics Applied to Polar Wobble

The polar wobble exhibits an annual component due to atmospheric variations. Specific influences can be calculated from appropriate pressure field measurements, if these are made at sites uniformly distributed over the Earth; unfortunately, this appears to be physically and politically impossible, and there are extensive regions from which needed data can not be obtained. The impact of inadequate coverage was noted by Wilson (1975): he compared atmospheric excitation functions published by a Soviet investigator, with functions derived by others and concluded that the rather significant differences were due to restricted availability of Siberian meteorology.

Atmospherics, like any phenomena conforming to a spherical surface, can be mathematically treated, most conveniently, using spherical harmonics. This has been done by a number of authors.<sup>17</sup> The process is complicated, however, by the need to maintain orthogonality of the functions. Kaula (1967) describes statistical analyses of data distributed over a sphere, and rigorous requirements to insure validity. Data gaps cause non-orthogonality and require analytical measures involving covariances; mere substitution of null values, followed by least-squares determinations or other devices, may result in inordinately specious harmonic coefficients. Although harmonic

---

<sup>17</sup> Includes Awade et al. (1975), Eliassen (1958), Eliassen and Machenhauer (1965), Ellsaesser (1966), Graham (1955), Hassan (1960), Haurwitz (1940), Moses (1974), Neatan (1946), Platzman (1960).

methods can be advantageously employed for limited area coverage, their applications to world-wide atmospherics do not appear to be feasible due to the limited scope of our present meteorological observing system.

Straightforward methods, for analyzing pressure field motions, probably provide a more satisfactory means for determining atmospheric influences. Seasonal variations in air mass distribution, which contribute to the annual component of polar wobble, can be estimated from the ground level pressure field. Seasonal wind variations do contribute to changes in the earth rotation rate, but, as shown by Munk and MacDonald (1960), these appear to have little or no effect on polar wobble. The data gap problem still exists, and there appears to be little likelihood of approaching a 50 percent representation. Since the actual effects can be determined rather positively from spectral analysis of long-period latitude observations (See Section 2.14), atmospheric analysis appears to offer little more than academic interest in the polar wobble application.

### 2.13 Earth Rotation

Earth rotation rate, referred to the inertial frame, affords a general measure of sidereal time. The fundamental unit of sidereal time is the mean sidereal day, the interval between two successive transits of the mean vernal equinox over a given meridian, corrected for polar motion and certain periodic irregularities in earth rotation rate. The more readily utilized solar time is based on the local hour angle of a

fictitious sun. Solar time, when referenced to a defined prime meridian, is termed universal time (UT). There are four UT systems in use: UT0 is observed UT; UT1 is UT0 corrected for the BIH definition of the prime meridian (corrected for polar wobble); UT2 is UT1 corrected for periodic variations in earth rotation; UTC (coordinated universal time) is the system used in radio time signal transmission, and is an approximation to UT1, obtained from international atomic time<sup>18</sup> (TAI) by the relationship,  $UTC = TAI - 15^S$ .

Rotation rate is continuously monitored by observatories of the BIH, which issues a monthly report of five-day raw and smoothed time and polar wobble data; these include values for UT2-UTC and UT1-UTC. More accurate determinations will become available with implementation of new techniques, most importantly, that of VLBI.

Principal variations in earth rotation rate are caused by tides, polar wobble and zonal wind circulation. Lesser, periodic influences, are due to atmospheric pressure and hydrological variables (snow, ground water, vegetation, etc.). Secular changes in rotation rate are due to core-mantle coupling and effect of lunar torque on the tidal bulge of the Earth.

Tidal effects include fortnightly, monthly, semi-annual and annual terms; polar wobble influences the rate over a fourteen-month period; zonal winds add semi-annual, annual and, intermittently, near-biennial contributions. Atmosphere pres-

---

<sup>18</sup> TAI is directly based on the data of atomic clocks.

sure and hydrological variables occur at semi-annual and annual frequencies. The core-mantle coupling effect is manifest in a secular variation of the geomagnetic field (See Section 1.17); it is a consequence of angular momentum conservation during variations in rotation rates between core and mantle. The effect of a lag in development of the tidal bulge (caused by imperfect elasticity and, thus, energy dissipation) is a torque by the Moon on the Earth, slowing the earth rotation.

Tidal effects can be theoretically calculated, but the meteorological measuring situation noted in Section 2.12 applies, and estimates of zonal wind influence are subject to considerable uncertainty; evaluations of atmospheric pressure and hydrological effects are highly conjectural; secular contributions are fairly observable.

Influences on earth rotation can be characterized by dimensionless excitation functions (See Sections 2.4 and 2.14). Lambeck and Cazenave (1973) give a number of these functions which are listed in Table 2.5.

Polar wobble does not have a direct effect on earth rotation. Astronomic coordinates of the time observatories must be corrected for the effect of polar wobble to insure proper orientation with the CIO and BIH prime meridian.<sup>19</sup> The fortnightly and monthly tidal terms do not lend themselves well to the format used for the excitation functions of the other terms; the lunar motion introduces a complication. Excitation functions for these (Munk and MacDonald (1960)) are

---

<sup>19</sup> See, also, Iijima and Okazaki (1972).

Table 2.5 Excitation Functions  $\Psi_3$ 

Period T (Months)	Coefficients		Geophysical Factor
	A	B	
6	-0.051	0.260	Zonal wind (altitude 0-30km)
6	0.050	0.010	Zonal wind (altitude 30-60km)
6	-0.0006	0.0000	Atmospheric pressure
6	0.003	-0.005	Ground water
6	0.161	-0.060	Earth tides
12	-0.344	-0.131	Zonal wind (altitude 0-30km)
12	-0.024	-0.010	Zonal wind (altitude 30-60km)
12	-0.0032	0.0027	Atmospheric pressure
12	0.017	0.022	Ground water
12	-0.028	-0.001	Earth tides
24	-0.077	0.029	Zonal wind (altitude 0-30km)
24	-0.001	-0.003	Zonal wind (altitude 30-60km)
6	0.162	0.205	Total for 6 month period
12	-0.382	-0.117	Total for 12 month period
24	-0.078	0.026	Total for 24 month period

Excitation function,  $\Psi_3 = A \cos \frac{2\pi t}{T} + B \sin \frac{2\pi t}{T}$ , where  $t$  is the number of months from Jan 0, 1958, and coefficients  $A$  and  $B$  are given in units of  $10^{-8}$ .

$$\begin{aligned}
 -\Psi_{Mf} &= 0.16 \times 10^{-8} \cos(2s-N) \\
 &+ 0.38 \times 10^{-8} \cos 2s
 \end{aligned} \tag{125}$$

and

$$-\Psi_{Mm} = 0.20 \times 10^{-8} \cos(s-p) \tag{126}$$

where Eq. (125) is the excitation function for the fortnightly

term and Eq. (126), for the monthly term. The arguments are

$$s = 270^{\circ}.434358 + 13^{\circ}.1763965268d_{\circ} - 0^{\circ}.001133T_{\circ}^2 + 0^{\circ}.0000019T_{\circ}^3, \quad (127)$$

$$N = 259^{\circ}.183275 - 0^{\circ}.0529539222d_{\circ} + 0^{\circ}.002078T_{\circ}^2 + 0^{\circ}.000002T_{\circ}^3, \quad (128)$$

$$p = 334^{\circ}.329653 + 0^{\circ}.1114040803d_{\circ} - 0^{\circ}.010325T_{\circ}^2 - 0^{\circ}.000012T_{\circ}^3, \quad (129)$$

where  $s$ ,  $N$  and  $p$  are the mean longitude of the moon, longitude of the mean ascending node of the lunar orbit, and mean longitude of the lunar perigee, respectively.  $T_{\circ}$  and  $d_{\circ}$  are defined as

$$T_{\circ} = d_{\circ}/36525 \quad (130)$$

and

$$d_{\circ} = \text{J.D. (obs)} - 2415020.0 \quad (131)$$

The total excitation function (Table 2.5 data and Eqs. (125) and (126)) is (in units of  $10^{-8}$ )

$$\begin{aligned} \Psi_3 = & 0.162 \cos \frac{2\pi t}{6} + 0.205 \sin \frac{2\pi t}{6} - 0.382 \cos \frac{2\pi t}{12} \\ & - 0.117 \sin \frac{2\pi t}{12} - 0.078 \cos \frac{2\pi t}{24} + 0.026 \sin \frac{2\pi t}{24} \\ & - 0.16 \cos(2s-N) - 0.38 \cos 2s - 0.20 \cos(s-p) \quad (132) \end{aligned}$$

The equation of motion is (See Eq. (140))

$$m_3 = \frac{1}{\omega C} (-\omega c_{33} - h_3 + \int_0^t N_3 dt) = \Psi_3, \quad (133)$$

where the right-hand side is represented by the arbitrary evaluation in Eq. (132). (Elements of (133) are defined in Section 2.14.) From Eq. (140),

$$m_3 = \Psi_3 \quad , \quad (134)$$

where, from Eq. (137),  $m_3 = \frac{\omega_3}{\omega} - 1$ , is the "direction cosine - 1" relating the rotation axis to the axis of figure. (See Figure 2.2 and footnote to Figure 2.1.)

The effect of core-mantle coupling is more difficult to characterize. Munk and MacDonald (1960) discuss the marked westward drift of the geomagnetic field and suggest the possibility of comparing observed westward drift with mantle rotation. A number of additional authors<sup>20</sup> have investigated the apparent correlation between geomagnetic and astronomical time observations. The consensus is that the correlation is positive and valid, it is difficult to numerically evaluate, and the matter bears further investigation. This item is discussed in more detail in Section 2.17.<sup>21</sup>

---

<sup>20</sup> These include Aoki (1969), Bondi and Littleton (1948), (1953), Bullard et al. (1950), Elsasser (1950), Iijima and Okazaki (1972), Kahle et al. (1967), Malin and Saunders (1973), Munk and Revelle (1952), Nagata (1965), Rochester (1960), (1968), (1973), Runcorn (1954), Siran (1969), Steenbeck and Helmis (1975), Triet (1974), Vestine (1952), (1953), Vestine and Kahle (1968), Yukatake (1962), (1972).

<sup>21</sup> The effect of the core-mantle coupling on polar wobble, as well, has been reported by several investigators; this will be discussed here.



Lambeck and Cazenave (1974) discuss uncertainties in several of their suggested excitation function values (shown in Table 2.5.) These estimated errors, coupled with greater ones for other functions, indicate that an earth rotation model could be subject to considerable error; however, the literature<sup>22</sup> presents evidence that uncertainties are significantly smaller than magnitudes. In addition, the EOM design affords a ready input facility as more valid data becomes available. The matter of correcting astronomical longitude observations for polar wobble effects (discussed above) is covered in Section 2.14, and provisions are made for such corrections in the computing modules.

A final note concerns the possible effect of solar winds on the earth rotation. Coleman (1974) suggested that the solar wind could measurably affect the rotation rate; Hirshberg (1972) and Hines (1974) point out that the effects would not be significant; Gribbin and Plagemann (1973) claim a variation of 10 msec (jump in AT-UT2) between August 7 and 8, 1972 during a great solar storm, confirming their predictions of such results; O'Hora and Penny (1973) saw no such result and, since a storm of the observed magnitude provided such minimal effects, feel that there are good grounds for believing that changes in the length of the day are induced

---

<sup>22</sup>Refer to Brouwer (1952), Challinor (1971), Fliegel and Hawkins (1967), Frostman et al. (1967), Guinot (1970), Iijima et al. (1964), Iijima and Okazaki (1972), Lambeck (1975), Markowitz (1970), Mintz and Munk (1951), (1954), Munk and MacDonald (1960), Munk and Revelle (1952), Rochester (1973), Sidorenkov (1968), (1973), Woolard (1959).

by some other mechanism. Evaluation of these reports indicates little likelihood for variations in earth rotation due to solar wind or flares.

#### 2.14 Polar Wobble

For convenience, the mathematical development for the polar wobble and Earth's rotation are discussed in this section. We follow Munk and MacDonald (1960) in the general approach. The basic equations for the polar wobble and rotation are the Liouville equations given in (97), which, in component form, are

$$\left. \begin{aligned} N_1 &= \dot{C}_{1j} \omega^j + C_{1j} \dot{\omega}^j + \dot{h}_1 + \omega_k (\omega_2 C^{3k} - \omega_3 C^{2k}) + \omega_2 h_3 - \omega_3 h_2 \\ N_2 &= \dot{C}_{2j} \omega^j + C_{2j} \dot{\omega}^j + \dot{h}_2 + \omega_k (\omega_3 C^{1k} - \omega_1 C^{3k}) + \omega_3 h_1 - \omega_1 h_2 \\ N_3 &= \dot{C}_{3j} \omega^j + C_{3j} \dot{\omega}^j + \dot{h}_3 + \omega_k (\omega_1 C^{2k} - \omega_2 C^{1k}) + \omega_1 h_2 - \omega_2 h_1 \end{aligned} \right\} (135)$$

Consider the perturbation scheme where, in the moment of inertia tensor,

$$C_{ij} = \begin{bmatrix} A+c_{11} & c_{12} & c_{13} \\ c_{21} & B+c_{22} & c_{23} \\ c_{31} & c_{32} & C+c_{33} \end{bmatrix}, \quad (136)$$

A, B and C are the moments of inertia referred to the principal axes and  $c_{ij}$  are small corrections and products of inertia for  $i=j$  and  $i \neq j$ , respectively. Let

$$\omega_1 = \omega m_1, \quad \omega_2 = \omega m_2, \quad \omega_3 = \omega(1+m_3), \quad (137)$$

where  $\omega = |\omega_i \omega^i|^{\frac{1}{2}}$ . Introducing (136) and (137) into (135) and setting  $B=A$ ,

$$\left. \begin{aligned} m_1 &= \frac{1}{\omega^2(C-A)} (\omega^2 c_{13} + \omega \dot{c}_{23} + \omega h_1 + \dot{h}_2 + A \omega \dot{m}_2 - N_2) , \\ m_2 &= \frac{1}{\omega^2(C-A)} (\omega^2 c_{23} - \omega \dot{c}_{13} + \omega h_2 - \dot{h}_1 - A \omega \dot{m}_1 + N_1) , \\ \dot{m}_3 &= -\frac{1}{\omega C} (\omega \dot{c}_{33} + \dot{h}_3 - N_3) . \end{aligned} \right\} (138)$$

It can be seen that  $\frac{c_{ij}}{C}$ ,  $m_i$  and  $\frac{h_i}{\omega C}$  are small, dimensionless quantities whose products and squares can be neglected. We set

$$\sigma_r = \frac{C-A}{A} . \quad (139)$$

Introducing (139) into (138), noting the vanishing products,

$$\left. \begin{aligned} -\frac{\dot{m}_2}{\sigma_r} + m_1 &= \frac{1}{A\sigma_r} (\omega c_{13} + \dot{c}_{23} + h_1 - \frac{\dot{h}_2}{\omega} - \frac{N_2}{\omega}) = -\phi_1 , \\ \frac{\dot{m}_1}{\sigma_r} + m_2 &= \frac{1}{A\sigma_r} (\omega c_{23} - \dot{c}_{13} + h_2 - \frac{\dot{h}_1}{\omega} + \frac{N_1}{\omega}) = \phi_2 , \\ m_3 &= -\frac{1}{C} (c_{33} + \frac{h_3}{\omega} - \frac{1}{\omega} \int N_3 dt) = \phi_3 . \end{aligned} \right\} (140)$$

The right hand terms represent the dimensionless excitation functions,  $\phi_i$ , and are determined by geophysical observations; the left-hand terms are determined by astronomical observations.

The first two of (140) represent the polar wobble equations of motion. They are more conveniently handled in complex

form, with

$$m = m_1 + im_2, \quad \phi = \phi_1 + i\phi_2, \quad ,$$

and written as the single equation,

$$i \frac{\dot{m}}{\sigma_r} + m = \phi \quad . \quad (141)$$

The third of (140) is the equation of motion for the earth rotation. Quantities  $N_i$ ,  $h_i$  and  $c_{ij}$  in (140) are qualified as follows:

a. The initial time  $t_0$  marks the instant the rotating  $x_i$  and fixed  $X_i$  frames coincide. All components of torque, momentum and inertia are referenced to the  $x_i$  axes.

b.  $N_i$  are exterior torques acting on the contents of a volume  $V$  which is arbitrary.

c. Quantities  $h_i$  and  $c_{ij}$  depend on the fields of density  $\rho(x_i, t)$  and relative velocity,  $u_j(x_i, t)$ , where  $\rho$  and  $u_j$  are independent variables subject to constraints of laws of conservation and equations of state.

d. Let  $y_i$  be a coordinate system rotating with the same angular velocity,  $\omega$ , as the  $x_i$  system, but with  $y_3$  directed always along the instantaneous rotation axis. Then,

$$x_i = \frac{\omega_i}{\omega} y_3 \quad , \quad (142)$$

so that  $\frac{\omega_i}{\omega}$  are the direction cosines of the rotation axis relative to the reference axis; thus, the wobble components are  $\omega_1$  and  $\omega_2$ .

The expression  $\sigma_r$  in (141) is based on a rigid Earth. From Jeffreys (1970), the total external gravitational potential is

$$U = \frac{Ga^2}{r^3} + U_2 + \frac{ka^5}{r^5} U_2 \quad , \quad (143)$$

and, from the same source, MacCullagh's formula for the gravitational potential from a distant point is

$$U = \frac{GM}{r} + \frac{G}{2r^3} (A + B + C - 3I) = \frac{GM}{r} + \frac{G}{2r^5} C_{ij} (r^2 \eta^{ij} - 3x^i x^j) \quad . \quad (144)$$

Equating equivalent components of (143) and (144),

$$GC_{ij} (r^2 \eta^{ij} - 3x^i x^j) = 2ka^5 U \quad , \quad (145)$$

where  $\eta^{ij}$  is the unit matrix. For a rotating deformable Earth, the concern is for the centrifugal potential,

$$U = \frac{1}{2} [\omega^2 r^2 - (\omega_i x^i)^2] = \frac{1}{3} \omega^2 r^2 + \frac{1}{6} [\omega_i \omega_j (r^2 \eta^{ij} - 3x^i x^j)] \quad . \quad (146)$$

Substituting the right-hand part of (146) (discarding the radial component,  $\frac{1}{3} \omega^2 r^2$ , since it has no influence) into (145) yields

$$C_{ij} = \frac{ka^5}{3G} \omega_i \omega_j \quad , \quad (147)$$

which can be written as

$$C_{ij} = I \eta_{ij} + \frac{ka^5}{3G} \omega_i \omega_j + \text{Constant} \quad ,$$

where  $I = \frac{1}{3} C_i^i$  is the inertia of the sphere, free of rotational deformation. This determines the constant and we have

$$C_{ij} = I\eta_{ij} + \frac{ka^5}{3G}(\omega_i\omega_j - \frac{1}{3}\omega^2\eta_{ij}) \quad (148)$$

Orienting the  $x_3$  axis along the rotation axis,  $\omega_1=\omega_2=0$ ,  $\omega_3=\omega$ , and

$$C_{11} = C_{22} = A = I - \frac{k_s a^5}{9G}\omega^2; \quad C_{33} = C = I + \frac{2k_s a^5}{9G}\omega^2 \quad (149)$$

Setting  $\frac{C-A}{C} = H$ , (H is known as the precessional constant)

we obtain

$$k_s = \frac{3GHC}{a^5\omega^2} \quad (150)$$

where  $k_s$  applies to the rotational case carried on for the total of the Earth's rotation time, and is known as the secular Love number. It is considered equivalent to the fluid Love number,  $k_f$ . The secular Love number has been evaluated as  $k_s=0.96$  (Munk and MacDonald (1960)), and this value is applied to  $k_f$ .

From (147) and (150), we find the products of inertia to be

$$c_{ij} = \frac{k}{k_f} \frac{C-A}{\omega^2} \omega_i\omega_j, \quad i \neq j \quad (151)$$

from which,

$$c_{13} = \frac{k}{k_f} (C-A) m_1, \quad c_{23} = \frac{k}{k_f} (C-A) m_2 \quad (152)$$

Substituting these into the first two of (140) (for the moment, disregarding  $h_i$  and  $N_i$ ),

$$\begin{aligned}\phi_1 &= \frac{k}{k_f} \left( m_1 + \frac{\dot{m}_2}{\omega} \right) , \\ \phi_2 &= \frac{k}{k_f} \left( m_2 - \frac{\dot{m}_1}{\omega} \right) .\end{aligned}\tag{153}$$

In the complex mode, these are written as

$$\phi = \frac{k}{k_f} \left( m - i \frac{\dot{m}}{\omega} \right) .\tag{154}$$

We set  $\psi_D = \frac{k}{k_f} m$ , and

$$\phi = \psi_D - i \frac{\dot{\psi}_D}{\omega} .\tag{155}$$

Introducing (155) into (141),

$$\frac{i\dot{m}}{\sigma_r} + m = \psi_D - i \frac{\dot{\psi}_D}{\omega} \sim \psi_D .\tag{156}$$

The approximation depends upon the magnitude of  $\frac{C-A}{A}$  and here the error  $\sim 0.1$  percent. The expression  $\psi_D$  may be interpreted as that part of the excitation function  $\phi$  that is due to rotational deformation. Then,

$$i\dot{m} + \sigma_0 m = 0 ,$$

which differs from the corresponding rigid Earth expression when  $\phi=0$ ,

$$i\dot{m} + \sigma_r m = 0 ,$$

in that the frequency of free nutation has been reduced from  $\sigma_r$

to

$$\sigma_0 = \sigma_r \frac{k_f - k}{k_f} \quad (157)$$

(We note again the adopted value,  $k=0.29$ , given in Section 2.9.)

The excitation function,  $\phi$ , may be defined in terms of a number of excitation components,  $\psi_i$ , dependent upon the nature of deformations or other geophysical phenomena. These will vary the frequency of wobble, but, if the excitation functions are properly defined, the corresponding wobble frequencies can be introduced. We consider excitation functions in the form,

$$\psi_i = \kappa \phi_i = \phi_i \quad ,$$

where  $\kappa$  is some transfer function separately considered for various geophysical excitations. Some excellent examples are given by Munk and MacDonald (1960), regarding this matter and various rotation poles for given excitations. The differential equations, using the general format are

$$\frac{i\dot{m}}{\sigma_0} + m = \psi \quad , \quad (158)$$

$$\dot{m}_3 = \dot{\psi}_3 \quad , \quad (159)$$

for the polar wobble and the Earth's rotation, respectively.

The solution of (158), which is of the form,

$$\frac{dM}{dt} + P(t)M - Q(t) = 0 \quad ,$$



which can be solved using the integrating factor,  $e^{\int P dt} = e^{-i\sigma_0 t}$ , is

$$m(t) = e^{i\sigma_0 t} \left[ m_0 - i\sigma_0 \int_0^t \Psi(\tau) e^{-i\sigma_0 \tau} d\tau \right], \quad (160)$$

where  $m_0$  is an arbitrary complex constant. Consider, first,  $\Psi(t) = JH(t)$ , where  $H(t)$  is the Heaviside step function. Then,  $m_0 = 0$ ,  $m = 0$  for  $t < 0$ , and

$$m(t) = J(1 - e^{i\sigma_0 t}), \quad t \geq 0. \quad (161)$$

The second case of interest is that for a harmonic excitation of any frequency,  $\sigma$ :

$$\Psi = \Psi^C \cos \sigma t + \Psi^S \sin \sigma t. \quad (162)$$

The four numbers  $\Psi_1^C$ ,  $\Psi_2^C$ ,  $\Psi_1^S$ ,  $\Psi_2^S$ , determine phase and amplitude of the excitation. It is also convenient to use alternate forms (See Section 2.4). The solution for the harmonic excitation is

$$m(t) = m e^{i\sigma_0 t} + \frac{\sigma_0 \Psi^+}{\sigma_0 - \sigma} e^{i\sigma t} + \frac{\sigma_0 \Psi^-}{\sigma_0 + \sigma} e^{-i\sigma t}, \quad (163)$$

with the forced frequency,  $\sigma$ .

The solution of (159) is

$$m_3 = \Psi_3. \quad (164)$$

The effects of polar wobble on observed astronomical latitudes and longitudes (or times) are determined as follows:

The transformation matrix,  $a_{ij}$ , for the transformation,

$$x_{(\text{Astro})} = a_{ij} x_{(\text{CIO})} ,$$

is

$$a_{ij} = \begin{bmatrix} \cos x_p & 0 & -\sin x_p \\ 0 & 1 & 0 \\ \sin x_p & 0 & \cos x_p \end{bmatrix} \cdot \begin{bmatrix} 1 & 0 & 0 \\ 0 & \cos y_p & -\sin y_p \\ 0 & \sin y_p & \cos y_p \end{bmatrix}$$

$$\approx \begin{bmatrix} 1 & 0 & -x_p \\ 0 & 1 & -y_p \\ x_p & y_p & 1 \end{bmatrix} , \quad (165)$$

where  $x_p = \frac{\Delta x}{R}$ ,  $y_p = \frac{\Delta y}{R}$ ;  $\Delta x$  and  $\Delta y$  are the linear, positive wobble displacements in the prime meridian and  $90^\circ$  E. longitude directions, respectively, and  $R$  is the Earth's mean radius. The small magnitudes of  $x_p$ ,  $y_p$  are considered in the approximations employed in (165). The transformation from the instantaneous rotation axis to the CIO axis is given by

$$x_{(\text{CIO})} = a_{ji} x_{(\text{Astro})} , \quad (166)$$

or

$$\begin{bmatrix} \cos \phi \cos \lambda \\ \cos \phi \sin \lambda \\ \sin \phi \end{bmatrix} = \begin{bmatrix} 1 & 0 & x_p \\ 0 & 1 & y_p \\ -x_p & -y_p & 1 \end{bmatrix} = \begin{bmatrix} \cos \phi_a \cos \lambda_a \\ \cos \phi_a \sin \lambda_a \\ \sin \phi_a \end{bmatrix} . \quad (166')$$

Utilizing first-order Taylor expansions,

$$\sin\phi = \sin\phi_a + \Delta\phi \cos\phi_a \quad ,$$

$$\cos\phi = \cos\phi_a - \Delta\phi \sin\phi_a \quad ,$$

$$\cos\lambda = \cos\lambda_a - \Delta\lambda \sin\lambda_a \quad ,$$

where  $\Delta\phi = \phi - \phi_a$ ,  $\Delta\lambda = \lambda - \lambda_a$  ,

we eventually find

$$\phi = \phi_a - (x_p \cos\lambda_a + y_p \sin\lambda_a) \quad , \quad (167)$$

$$\lambda = \lambda_a - (x_p \sin\lambda_a - y_p \cos\lambda_a) \quad , \quad (168)$$

$$t = t_a - \frac{1}{15} (x_p \sin\lambda_a - y_p \cos\lambda_a) \tan\phi_a \quad , \quad (169)$$

where in (167) through (169),  $x_p$ ,  $y_p$  are given in arc seconds, and the corrective terms are in arc seconds, as well (units are seconds of time in (169)). We mention, again, the convention difference, geodesy vs. astronomy, with the former taking  $y$  as positive toward  $90^\circ$  E. longitude, and the latter, otherwise. This difference is reflected in equations given, for example, in Bomford (1971) and Mueller (1969), compared with those taken with the geodetic convention, as above.

The investigation of polar wobble is well documented

in the literature;<sup>2 3</sup> however, despite a plethora of research and theorizing, there is no real agreement about the source and dissipation of the force which appears to permanently maintain the Chandler component of the wobble. Most agree on the existence of a rather consistent annual component, and some fewer, on an equally consistent semi-annual component.

The instantaneous polar wobble represents the integration over the Earth's lifetime of all mass redistributions within, under and above its crust. Periodic contributors are seasonal motions of the atmospheric mass; ocean and bodily tides, with additional contributions due to asymmetric distribution of land and ocean areas; ground water, snow and vegetation changes; ocean effects such as surface height variations

---

<sup>2 3</sup> In addition to the authors already referenced above, those reviewed in connection with the EOM program include Anderle (1973), (1975), Arun and Mueller (1971), Ben-Menahem and Israel (1970), Beuglass and Anderle (1972), Capitaine (1975), Chinnery and Wells (1972), Colombo and Shapiro (1968), Currie (1974), Feissel et al. (1972), Gaposchkin (1972), Graber (1974), (1976), Guinot (1965), (1972), Haurbrich (1970), Israel et al. (1973), Jeffreys (1916), (1940), (1968), (1972), Jeffreys and Vicente (1957a), (1957b), Lambeck (1972), Liu et al. (1974), Mansinha and Smylie (1967), (1940), Markowitz (1940), McCarthy (1974), McClure (1976), Mueller and Schwarz (1972), Munk and Grove (1952), Myerson (1970), O'Connell and Dziewonski (1976), O'Hara and Thomas (1970), Okazaki and Nasaka (1972), Pedersen and Rochester (1972), Pines and Shaham (1973), Proverbio et al. (1972). Rochester (1970), Rochester et al. (1974), Rosenhead (1929), Rudnick (1956), Runcorn (1970), Rykhlova (1967), (1969), (1974), Shimazaki and Takeuchi (1972), Smylie and Mansinha (1968), (1971), Smylie et al. (1970), Toomre (1974), Vaniček (1969), Vicente and Yumi (1969), (1970), Walker and Young (1955), (1956), Wako (1972), Yashkov (1965), Yatskiv et al. (1973), Yumi and Wako (1970).

(inverted barometer phenomena), although mass transport contributes only an insignificant amount. Efforts to directly analyze these periodic effects fail due to lack of complete coverage by observation and processing techniques; however, spectral analyses of latitude data, observed over a number of decades, afford consistent and apparently quite representative excitation functions. Refer to Gaposchkin (1972) and Wilson (1975), for example, and to Section 5.2 for a detailed description.

Spectral analyses of ILS polar data from 1900 to 1975 are shown in Figures 2.8 through 2.10. The plot in Figure 2.8 is unfiltered; the plot in Figure 2.9 represents time data treated with a Hann filter;<sup>25</sup> the plots in Figure 2.10 are for four groupings of 30-year series against the overall 76 year series. This last figure gives the power in logarithmic form to provide better low-power detail. It can be seen that all plots show a specific high power at precisely the  $2\pi$  frequency (annual period). Figure 2.8 shows three additional peaks at 5.21, 5.39 and 5.65 rad/yr, while Figure 2.9 shows a fourth at 5.03 rad/yr. It might be assumed that the unfiltered indicates three Chandler frequencies, and the filtered one, four; however, Pedersen and Rochester (1972) suggest that too much confidence should not be placed on the discrimination validity of

---

<sup>25</sup> Hann filtering represents a premultiplication of time domain data by  $\frac{1}{2}(1-\cos(2\pi j/n))$ , where  $j$  represents the point number of the equispaced time series of  $n$  elements. The purpose is to cause spurious side bands to decay at an inverse third- rather than first-order rate.

Figure 2.8 Power Spectra (Without Filter)

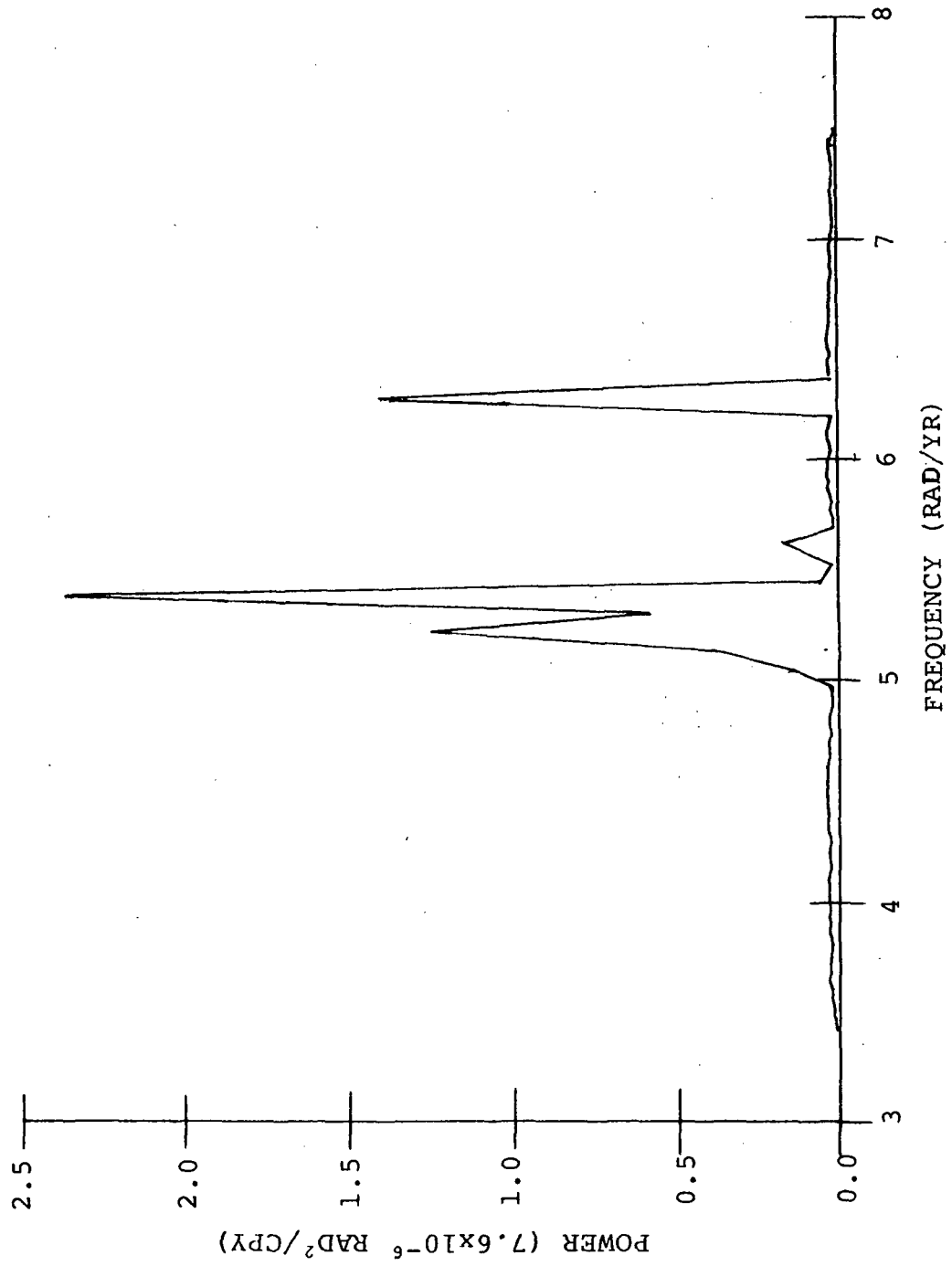

Figure 2.9 Power Spectra (With Hann Filter)

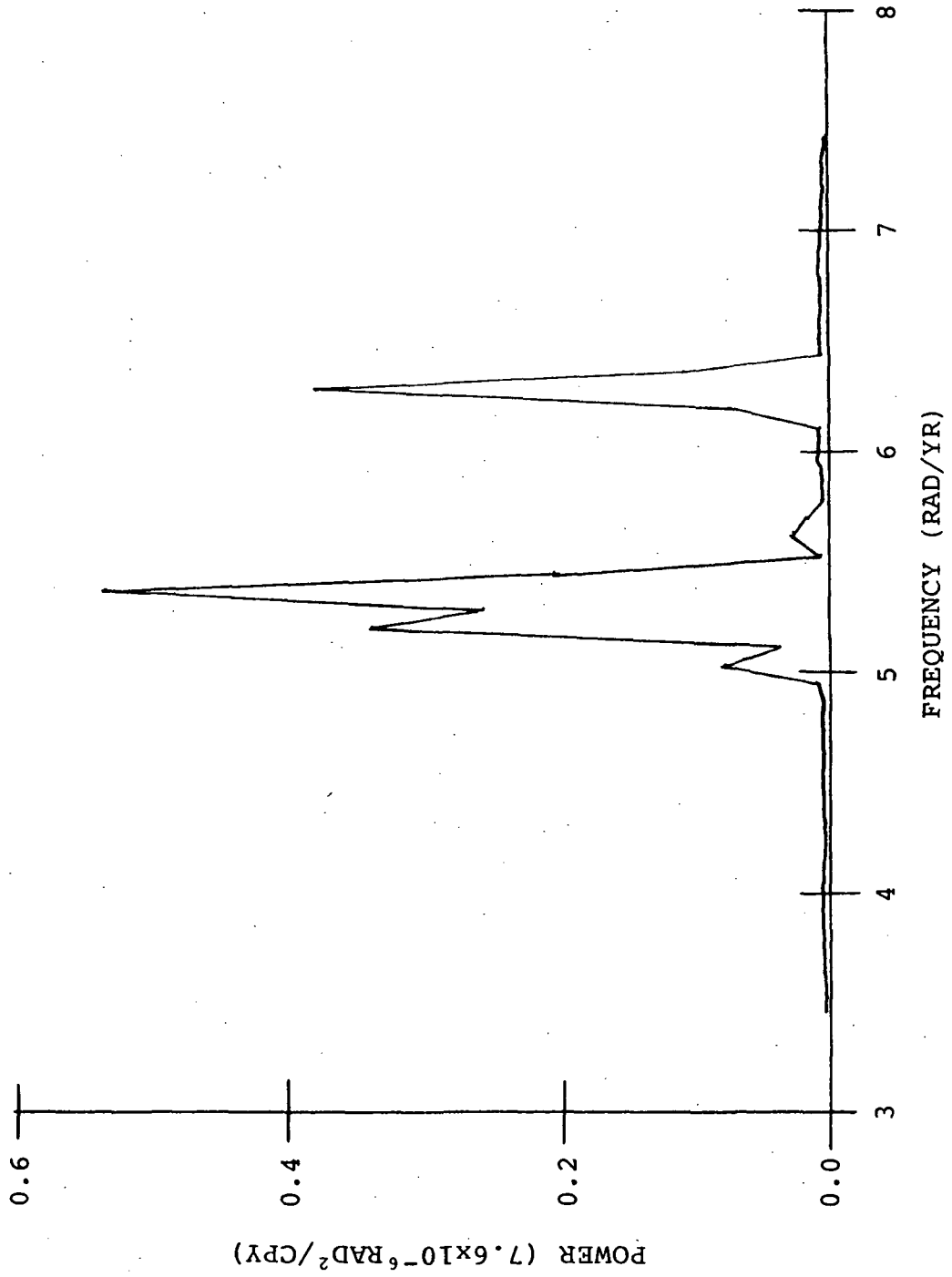

Figure 2.10 Power Spectra (Without Filter)

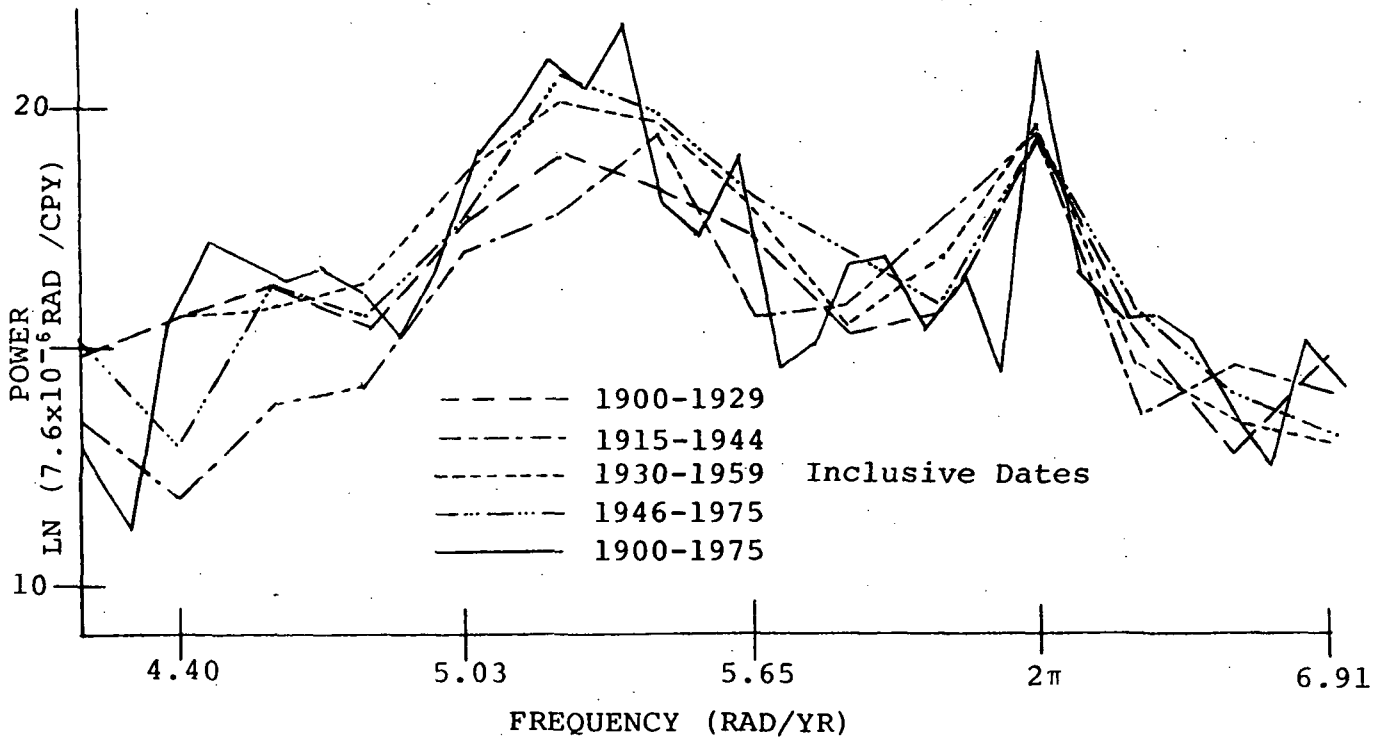
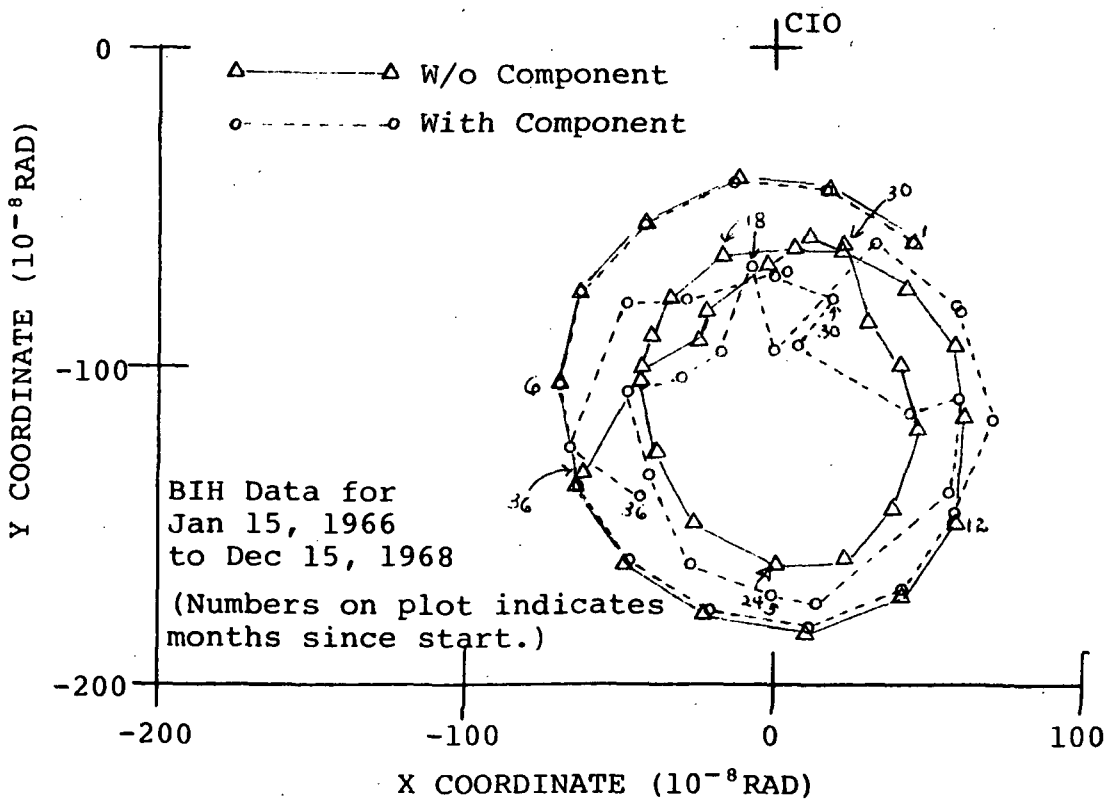

Figure 2.11 Polar Plot (With and Without Annual Component)





spectral analyses due to the limited (in their case, 70 year) observation period, and that the Chandler period may really be a single valued quantity. We agree with the statement of non-validity, but the matter of whether the Chandler frequency is a single or multiple valued function is not clear. The many contributors to its value (from oceans, crust and core), and the heterogeneous constituency of crust and upper mantle, leave this as a highly unresolvable matter. In addition, the Q factor (discussed below) has a definite influence on the period, and there may be several Q values involved which could have radically different values for oceans and Earth. For computation purposes we have arbitrarily chosen a Chandler frequency<sup>26</sup> of 5.3 rad/yr and a Q factor of 50. (These values represent implied consensuses (general averages).)

Polar plots of BIH data are shown in Figure 2.11 for the period 1966.04 to 1968.96. The two plots show the motion with and without the annual and semi-annual excitation components. The process for removing these periodic components is described in Section 5.2. A comparison of the ILS (IPMS) with the BIH data (both corrected for annual and semi-annual contributions) is given in Figure 2.12 for the same period.

The fact that the Chandler period is longer than the theoretical Euler (rigid Earth) period is due to bodily deformation and effects of oceans and liquid core. These involve an

---

<sup>26</sup> Several authors (including, but not limited to, Chandler (1891), Graber (1976), Jeffreys (1940), (1968), Munk and MacDonald (1960), Rudnick (1956), and Yashkov (1965)) have determined one or more Chandler frequencies based on spectral and other analyses.

Figure 2.12 ILS vs. BIH Polar Plot

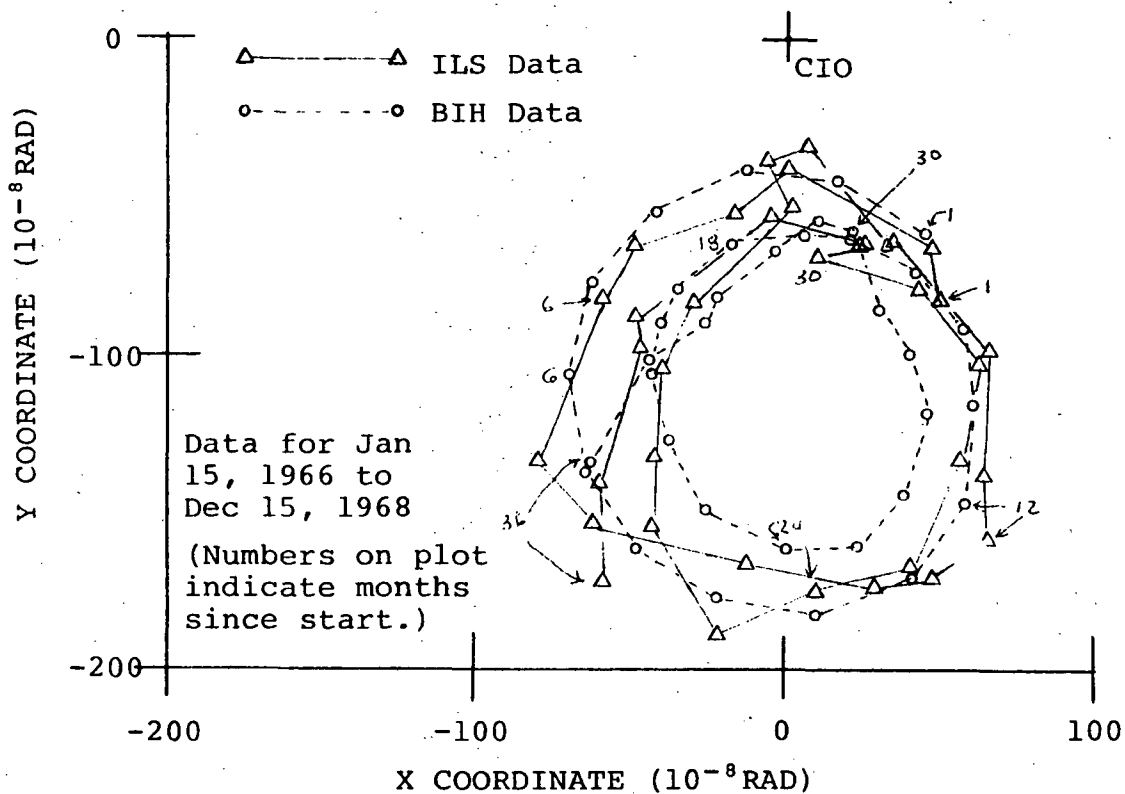

exchange of energy and imply some dissipation rate at the Chandler frequency. This requires that the Chandler frequency be complex, the dissipation appearing in the imaginary term, or

$$\hat{\sigma}_0 = \sigma_0 \left(1 + \frac{i}{2Q}\right) \quad , \quad (170)$$

where the  $Q$ , or quality factor, is the inverse of what is known as the specific dissipation function, given by

$$\frac{2\pi}{Q} = \frac{\Delta E}{E} = \frac{1}{E} \oint E \, dt \quad , \quad (171)$$

which is defined as the ratio of energy dissipation to total energy, occurring in a single cycle. Kaula (1968) shows that

the kinetic energy has a phase lag  $\frac{2\alpha}{\sigma_0}$ ,

$$Q = \frac{\sigma_0}{2\alpha} \quad , \quad (172)$$

and, in terms of thermodynamics, the dissipation factor is related directly to the change in entropy per cycle,  $\Delta S$ , or

$$\frac{1}{Q} = \frac{T\Delta S}{2\pi E} \quad ; \quad (173)$$

where  $T$  is the Kelvin temperature. If, then, in Eq. (160),  $\Psi(t)$  were to remain constant, wobble motion would decay in a time  $\frac{Q}{\sigma_0}$  and the axes of rotation and excitation would ultimately coincide; i.e., noting

$$\hat{\sigma}_0 = \sigma_0 + i\alpha \quad , \quad (174)$$

$$\lim_{t \rightarrow 0} m(t) = \lim_{t \rightarrow 0} e^{i\sigma_0 t} \left[ e^{-\alpha t} m_0 + \Psi(e^{-i\sigma_0 t} - 1) \right] = \Psi(e^{-i\sigma_0 t} - 1) \quad ;$$

thus, characterization of Chandler excitation functions requires frequency and dissipation factors for each component, as well as initial magnitudes and orientations.

Attempts to demonstrate the source of energy driving the Chandler wobble have not been too successful. Wilson (1975) concluded that meteorological variations account for a significant portion, but not all of the wobble, and that other non-meteorological sources, such as earthquakes should not be excluded from consideration. Mansinha and Smylie (1967), (1970), Smylie and Mansinha (1968), Smylie et al. (1970) all indicate a high degree of correlation between changes in pole path and

earthquakes with magnitude,  $M > 7.5$ , in recent years. Pines and Shaham (1973) claim to show that the Chandler wobble and earthquakes may have a common excitation source with the right sign and strength to explain the "pumping" of the Chandler wobble. O'Connell and Dziewonski (1976) conclude from analysis of 234 earthquakes with  $M \geq 7.8$  (occurring between 1901 and 1970) that earthquakes represent the major factor in wobble excitation. Myerson (1970) finds strong support for the Mansinha and Smylie (1967) theory but feels that the earthquakes, themselves, are not the source but a parallel effect to the wobble excitation. Ben-Menahem and Israel (1970) find that an earthquake of magnitude 8.5, under favorable circumstances, may suffice to maintain the wobble for about one year; hence they deduce that earthquakes may at most account for 30 percent of the observed secular polar shift. A strong rejection of the Mansinha and Smylie theory was made by Haubrich (1970) who found that the excitation, from actual historical events, is at least an order of magnitude too low to maintain the observed wobble. O'Hara and Thomas (1970) report negatively on the earthquake as being a significant source, while Chinnery and Wells (1972) feel the matter is still open but not resolvable with present data. Runcorn (1970) feels that treatment of earthquake effects as step functions is incorrect and that the input should be impulse types. Israel et al. (1973) feel that earthquakes are insufficient to maintain the Chandler wobble. It was determined in the course of this EOM study that seismic disturbances leading to earthquakes could, indeed, be responsible for the major portion

of the Chandler wobble power as well as the secular drift of the mean pole. The seismic contribution is impossible to realistically preprogram and, since its magnitude far outweighs that of any other possible source (and these issues are so thoroughly treated in the literature), no further discussion will be made of Chandler components. Details of the EOM findings are given in Section 5.2.

### 2.15 Earth Tides

The complete tidal potential can be written as

$$W = \frac{GM}{\rho} = \frac{GM}{r \left(1 - 2\frac{R}{r} \cos \zeta + \frac{R^2}{r^2}\right)^{1/2}} = \frac{GM}{r} \sum_{n=0}^{\infty} \left(\frac{R}{r}\right)^n P_n(\mu) \quad , \quad (175)$$

where, referring to Figure 2.5,  $\rho = \overline{PM}$ ,  $r = \overline{x_i}$ ,  $R = \overline{OP}$ , and  $P_n$  are the Legendre polynomials described in Section 2.6. From (53) and (175),

$$W_0 = \frac{GM}{r}, \text{ a constant affording no tidal effect,}$$

$W_1 = \frac{GM}{r^2} R \cos \zeta$ , which provides a radial potential applying to the Kepler-Newtonian equations for orbital motion, but is not part of the tidal effect, and,

$$W_2 = \frac{GM}{2} \frac{R^2}{r^3} (3 \cos^2 \zeta - 1) \quad , \quad (176)$$

$$W_3 = \frac{GM}{2} \frac{R^3}{r^4} (5 \cos^3 \zeta - 3 \cos \zeta) \quad , \quad (177)$$

$$W_4 = \frac{GM}{8} \frac{R^4}{r^5} (35 \cos^4 \zeta - 30 \cos^2 \zeta + 3) \quad , \quad (178)$$

.....

Eq. (176) is the same expression given earlier in (75) and (92); note, also, that  $R \ll r$ , which explains the relative vanishing of  $W_3, W_4, \text{etc.}$ , with respect to  $W_2$ . Substituting

$$\cos \zeta = \sin \phi \sin \delta + \cos \phi \cos \delta \cos (t + \lambda) \quad (179)$$

and the decomposition formula,<sup>27</sup>

$$P_n(\cos \psi) = P_n(\cos \theta) P_n(\cos \theta') + 2 \sum_{m=1}^n \frac{(n-m)!}{(n+m)!} \left[ R_{nm}(\theta, t) R_{nm}(\theta', \lambda) + S_{nm}(\theta, t) S_{nm}(\theta', \lambda) \right]; \quad (180)$$

where  $\phi, \lambda$  is the latitude and longitude of the point P, respectively,  $\delta, t$  is the declination and hour angle of the exterior body, respectively,  $\theta = 90^\circ - \phi$ ,  $\theta' = 90^\circ - \delta$ ,

$$R_{nm} = P_{nm}(\cos \theta) \cos(mt),$$

$$S_{nm} = P_{nm}(\cos \theta) \sin(mt),$$

into Eqs. (176) through (178), we eventually obtain,

$$W_2 = \frac{3GMR^2}{4r^3} \left[ 3 \left( \sin^2 \phi - \frac{1}{3} \right) \left( \sin^2 \delta - \frac{1}{3} \right) + \sin 2\phi \sin 2\delta \cos(t + \lambda) + \cos^2 \phi \cos^2 \delta \cos 2(t + \lambda) \right], \quad (181)$$

$$W_3 = \frac{GMR^3}{8r^4} \left[ 2(5\sin^3 \phi - 3\sin \phi)(5\sin^3 \delta - 3\sin \delta) + 3\cos \phi \cos \delta (5\sin^2 \phi - 1)(5\sin^2 \delta - 1) \cos(t + \lambda) + 30\sin \phi \sin \delta \cos^2 \phi \cos^2 \delta \cos 2(t + \lambda) + 5\cos^3 \phi \cos^3 \delta \cos 3(t + \lambda) \right],$$

---

<sup>27</sup> Refer to a text discussing spherical harmonics; e.g., Heiskanen and Moritz (1967).

These can be combined into long period, diurnal, semi-diurnal, ter-diurnal, quarter-diurnal, etc., tides:

$$\begin{aligned}
 W = & \left\{ \frac{GMR^2}{64r^3} 16(3\sin^2\phi-1)(3\sin^2\delta-1) + \frac{16R}{r} (5\sin^3\phi-3\sin\phi)(5\sin^3\delta-3\sin\delta) \right. \\
 & + \frac{R^2}{r^2} (35\sin^4\phi-30\sin^2\phi+3)(35\sin^4\delta-30\sin^2\delta+3) \\
 & + \left[ 48\sin 2\phi \sin 2\delta + \frac{24R}{r} \cos\phi \cos\delta (5\sin^2\phi-1)(5\sin^2\delta-1) \right. \\
 & \left. + \frac{40R^2}{r^2} \cos\phi \cos\delta (7\sin^3\phi-3\sin\phi)(7\sin^3\delta-3\sin\delta) \right] \cos(t+\lambda) \\
 & + \left[ 48\cos^2\phi \cos^2\delta + \frac{240R}{r} \sin\phi \sin\delta \cos^2\phi \cos^2\delta + \frac{20R^2}{r^2} \cos^2\phi \cos^2\delta (7\sin^2\phi-1) \right. \\
 & \left. (7\sin^2\delta-1) \right] \cos 2(t+\lambda) \\
 & + \left[ \frac{40R}{r} \cos^3\phi \cos^3\delta + \frac{280R^2}{r^2} \sin\phi \cos^3\phi \sin\delta \cos^3\delta \right] \cos 3(t+\lambda) \\
 & + \frac{35R^2}{r^2} \cos^4\phi \cos^4\delta \cos 4(t+\lambda)
 \end{aligned} \tag{182}$$

For all practical purposes of the EOM, the expansion of  $W_2$  as given in (181) is adequate for  $W$ .

As mentioned in the introduction, the total tide represents the sum contributions of all its components. There are at least 31 major contributors; each operate like a separate tide inducing body traveling at its own individual rate. It has been found that all tides can be expressed in terms of one or more of a set of six variables. Doodson (1921) describes the procedure and sets up a systematic classification

for these tidal waves. The defining variables are

$$\begin{aligned}
 \tau &= 15^{\circ}.0 t + h - s - \lambda \quad , \\
 s &= 277^{\circ}.0248 + 481267^{\circ}.8906T + 0^{\circ}.0020T^2 \quad , \\
 h &= 280^{\circ}.1895 + 36000^{\circ}.7689T + 0^{\circ}.0003T^2 \quad , \\
 p &= 334^{\circ}.3853 + 4069^{\circ}.0340T - 0^{\circ}.0103T^2 \quad , \\
 N' &= 100^{\circ}.8432 + 1934^{\circ}.1420T - 0^{\circ}.0021T^2 \quad , \\
 p_1 &= 281^{\circ}.2209 + 1^{\circ}.7192T + 0^{\circ}.0005T^2 \quad ,
 \end{aligned}
 \tag{183}$$

where,

$$T = (\text{Julian Date}_{(\text{Obs})} - 2415020.5)/36525,$$

$\tau$  is the local mean lunar time reduced to angle,  $s$  is the Moon's mean longitude,  $h$  is the Sun's mean longitude,  $p$  is the longitude of Moon's perigee,  $N' = -N$ , where  $N$  is the longitude of the Moon's ascending node,  $p_1$  is the longitude of the Sun's perigee and  $\lambda$  is the longitude of the station.

The speeds per mean solar day are

$$\begin{aligned}
 \dot{\tau} &= 360^{\circ}.0 - 12^{\circ}.19074939 \quad , \\
 \dot{s} &= 13^{\circ}.17639673 \quad , \\
 \dot{h} &= 0^{\circ}.98564734 \quad , \\
 \dot{p} &= 0^{\circ}.11140408 \quad , \\
 \dot{N}' &= 0^{\circ}.05295392 \quad , \\
 \dot{p}_1 &= 0^{\circ}.00004747 \quad .
 \end{aligned}
 \tag{184}$$

Doodson's classification is in terms of the arguments defined in (183) which would apply to a given tidal wave. For example, the argument for the  $R_2$  wave is

$$R_2: 2\tau - h + 2s - p_1 \quad .$$



Doodson's classification is a six digit one,

$$a, (b+5), (c+5), (d+5), (e+5), (f+5), \quad (185)$$

where the letters, above, are the coefficients of the wave expression,

$$a + bs + ch + dp + eN' + fp_1 .$$

Finally, there is a decimal separating the third from the fourth coefficient in (185). The classification for  $R_2$  is, therefore,

$$R : 274.554 .$$

Note that the larger the argument number, the greater is the speed of the component tidal wave.

The harmonic development of the equilibrium tide is discussed in Section 2.16 where its application will have more relevance.

The influence of luni-solar tides on the deformable Earth was described in Section 2.8. It was assumed there that the tide was an equilibrium one, and no consideration was made of what is known as the secondary tidal effect, that due to Earth loading by oceanic tides. The equilibrium concept applies fairly well to Earth tides with the exception of some phase angle in the tidal bulge due to a given tide. Phase angles vary (they may be positive as well as negative) at a given station for a given tide.<sup>28</sup> Although expressions are given (see, e.g., Kaula (1968)) for the lag angle, they depend upon variables which are not available.

---

<sup>28</sup> See Melchior (1966).

Darwin (1879) appears to have made the first calculations on tidal loading of the Earth's surface (secondary effect), taking into account the distortion of the Earth's surface. The problem of effects on the vertical deflection was presented in a rather comprehensive fashion by Lamb (1917). Theoretical effects based on various Earth models were discussed by a number of authors including Alsop and Kuo (1964), Caputo (1962), Longman (1962), (1963), (1966), and Takeuchi (1950), the latter being an especially comprehensive treatment. Lambert (1974) applied tidal spectroscopy methods (developed by Munk and Cartwright (1966)) to analyses of total gravity and tilt data to develop a weighting system to describe the Earth tide more accurately in an environment of complex ocean tide perturbations. A study by Nishimura (1950) indicated that elasticity of the Earth's mantle is 20 to 30 percent smaller in the N-S than in the E-W direction. Kuo and Ewing (1966) noted that ocean tidal loading effects decay approximately exponentially as a function of station distances from the effective ocean water; however, for stations in the immediate ocean vicinity, tidal loading effects on tidal gravity, due to land tidal conditions, is very complex, small and irregular. Kuo and Jachens (1970) investigated the continental tidal gravity profile across the United States and found that tidal characteristics of both oceans entered, but they could find no observable correlation between tidal gravity parameters and regional geology. Lambert (1942) had already

determined that at inland stations the secondary effects may be perceptible for considerable distances, even as much as 4000 kilometers, and that at coastal stations, secondary effects could mask out entirely the primary effects; his work suggested that (See Eq. (181)) component hour angles should be modified by subtracting appropriate phase angles  $\epsilon_1$ ,  $\epsilon_2$ .

The effects of ocean loading can be measured by using gravimeters, tiltmeters, horizontal pendulums and extensometers (strain gauges). A complete description of instruments and techniques is given by Melchior (1966), and Slichter (1970) provides an excellent and comprehensive treatment of observational efforts to measure interaction of ocean and land tides and describes efforts and results at a number of stations. Investigation of local effects have been conducted by Beavan (1974), Egedal (1959), Harrison et al. (1963), Lambert (1970) and Lennon (1962).

Interactions between Earth and ocean tides were studied by Kozai (1965) who found that effects of the tides are about 10 percent of the direct luni-solar effects on the satellite, and that eccentricity, as well as the semi-major axis, are not disturbed except for short-term periodicities. Lambeck et al. (1974) found that consideration of the attraction of ocean tides was quite important in utilizing satellites for determining the Love number  $k$ , and that an equilibrium theory was not adequate for correcting for ocean tides; after more appropriate treatment, improved values of  $k$  were obtained, but poor solutions for phase angles indicated a need for more precise

... ..  
... ..  
... ..  
... ..

... ..  
... ..  
... ..  
... ..  
... ..

... ..  
... ..  
... ..  
... ..  
... ..

... ..  
... ..  
... ..  
... ..  
... ..

... ..  
... ..  
... ..  
... ..

satellite tracking data and tidal models.

There appears to be no analytical means for introducing corrections for secondary effects into the EOM, and no bases for adopting values for phase angles. Munk and MacDonald (1960) indicate a relationship between phase angle and  $Q$  (for large  $Q$ ),

$$\epsilon = \tan^{-1} \left( \frac{1}{2Q} \right) ,$$

which, for a  $Q$  of 50 (adopted arbitrarily for the EOM), indicates an  $\epsilon = 0^{\circ}.57$ . This, of course, is merely a generalization, and values given in Melchior (1966) indicate no possibility for presupposing a fixed phase angle. In fact, the wide range of magnitudes and signs leaves this parameter as a unique element to be specified only from direct observations for given components of the tide. The EOM does not incorporate phase angle values for given stations but, instead treats the luni-solar influence as an equilibrium tide; however, values as they become available, can be readily introduced if desired.

The number of tides considered for the EOM have been reduced to three components in each of the long period, diurnal, and semi-diurnal classes. These are the  $S_{sa}$ ,  $M_m$ ,  $M_f$ ,  $O_1$ ,  $P_1$ ,  $K_1$ ,  $N_2$ ,  $M_2$ ,  $S_2$  components with argument numbers:

$$\left[ \begin{array}{lll} S_{sa} : 057.555 & O_1 : 145.555 & N_2 : 245.655 \\ M_m : 065.455 & P_1 : 163.555 & M_2 : 255.555 \\ M_f : 075.555 & K_1 : 165.555 & S_2 : 273.555 \end{array} \right] . \quad (186)$$

## 2.16 Ocean Tides

The familiar ocean tide appears to an observer on shore as a repetitive, systematic rise and fall of the ocean level. The range of the tide varies with relative positions of Sun and Moon, and, sometimes, quite spectacularly: when the coastal configuration lends itself to resonance conditions,<sup>29</sup> which can cause extremes in highs and lows. Constraints imposed by land systems provide unique local circumstances which can be closely characterized by a finite system of descriptive parameters called harmonic tidal constituents.

The method of harmonic analysis was first developed by Thomson (1875), and perfected by Doodson (1921) into a successful system; Doodson (1957) was also the first to successfully treat for shallow water constituents. In practice, tidal constituents are determined by harmonic analysis of extended tidal height measurements, in the following general fashion: Let the observation equations be written for the  $k$  constituents as

$$\sum_{r=1}^k A_r \cos \omega_r t_i + B_r \sin \omega_r t_i + h_0 - h_i = v_i \quad , \quad (187)$$

where  $i = -n, -n+1, \dots, 0, \dots, n-1, n$ , are the observations taken at uniform intervals  $\Delta t$ , where  $n=0$  is the middle observation of the time series, for which  $t_0=0$ ;  $A_r, B_r$  are magnitudes of the tidal constituents to be determined;  $h_0$  is

---

<sup>29</sup> See Garrett (1972)

the mean level to be determined;  $\omega_r$  are the known frequencies associated with the selected tidal constituents,  $h_i$  are the observed amplitudes at the times  $t_i$ , and  $v_i$  are the residuals whose summed squares are to be minimized. As many constituents  $(A, B)_r$  are chosen as will completely satisfy the unique characteristics of the local tide; e.g., for Anchorage, Alaska, Zetler and Cummings (1967) required 114 constituents to properly define the tide.

The height of the tide at any coastal point and time may be represented by the expression,

$$f = f_0 + \sum_{n=1}^k f_n h_n \cos(\omega_n t - \phi_n) \quad , \quad (188)$$

where  $f_0$  is the mean height in respect to a reference level;  $h_n$  are mean amplitudes of constituents during the extended period over which  $h_n$  were determined;  $f_n$  are node factors depending on variables  $p$ ,  $N'$  and  $p_1$  for which the periods are approximately 8.6, 18.6 and 21,000 years, respectively;  $t$  is the time in UT;  $\phi_n = -q\lambda + \kappa_n - \omega_n S - (V_n + u_n)$ ;  $\lambda$  is the longitude of the point east of Greenwich;  $q$  is the species number (0 for long-period, 1 for diurnal, 2 for semi-diurnal, etc.);  $(V_n + u_n)$  are equilibrium constituents at Greenwich;  $S$  is the number of hours which standard time at the site follows Greenwich;  $g_n = \kappa_n - q\lambda - \omega_n S$ , and, together with  $h_n$ , are called the harmonic constants for the point. Procedure is to determine  $\phi_n$  for a given period, together with  $h_n$  and find the value  $g_n$  from the above. Averages of  $h_n$ ,  $g_n$  over an 18.6 year cycle

are utilized, and  $\kappa_n$  are phase lags of the tidal constituents behind the corresponding equilibrium constituents at Greenwich. Constants  $f_n$  and  $(V_n + u_n)$  are computed and available in Shureman (1941).

Equation (188) fails for tides in open oceans (pelagic tides). Water speed limitations of various tidal waves, and Coriolis effect present problems which must be solved in some other manner. The basis for modern efforts are solutions of Laplace's tidal equations. The involved mathematics and restrictions are given by Hendershott (1975), as well as the general status of numerical modeling of ocean tides. Difficulties involved in modeling the pelagic tide include requirements for specifying ocean depths and boundaries. Since both are highly irregular and not analytic, a complete mathematical solution is impossible. Investigators must specify boundaries in the forms of meridians and parallels, and uniform depths, in order to achieve any solution at all.<sup>30</sup>

The resultant of motions of tidal waves affected by the Coriolis forces and moderating influences of land masses, result in each component of the tide forming individual amphidromic systems. A sample of an amphidromic system for the  $M_2$  tide, taken from Luther and Wunsch (1975) is shown in Figure 2.13.

Amphidromic points are points where, for that particular tidal component, the water level remains fixed in height.

---

<sup>30</sup> See Doodson (1927), (1936), Goldsbrough (1927), (1929), Hendershott (1975), Pekeris and Accad (1969), Proudman (1916), (1925), (1932), (1936), (1944).



1. The first part of the document discusses the importance of maintaining accurate records of all transactions and activities. It emphasizes that this is essential for ensuring transparency and accountability in the organization's operations.

2. The second part of the document outlines the various methods and tools used to collect and analyze data. It highlights the need for consistent data collection procedures and the use of advanced analytical techniques to derive meaningful insights from the data.

3. The third part of the document focuses on the role of technology in data management and analysis. It discusses how modern software solutions can streamline data collection, storage, and processing, thereby improving efficiency and accuracy.

4. The fourth part of the document addresses the challenges associated with data management, such as data quality, security, and privacy. It provides strategies to mitigate these risks and ensure that the data remains reliable and secure throughout its lifecycle.

5. The fifth part of the document concludes by summarizing the key findings and recommendations. It stresses the importance of a data-driven approach in decision-making and the need for continuous monitoring and improvement of the data management process.

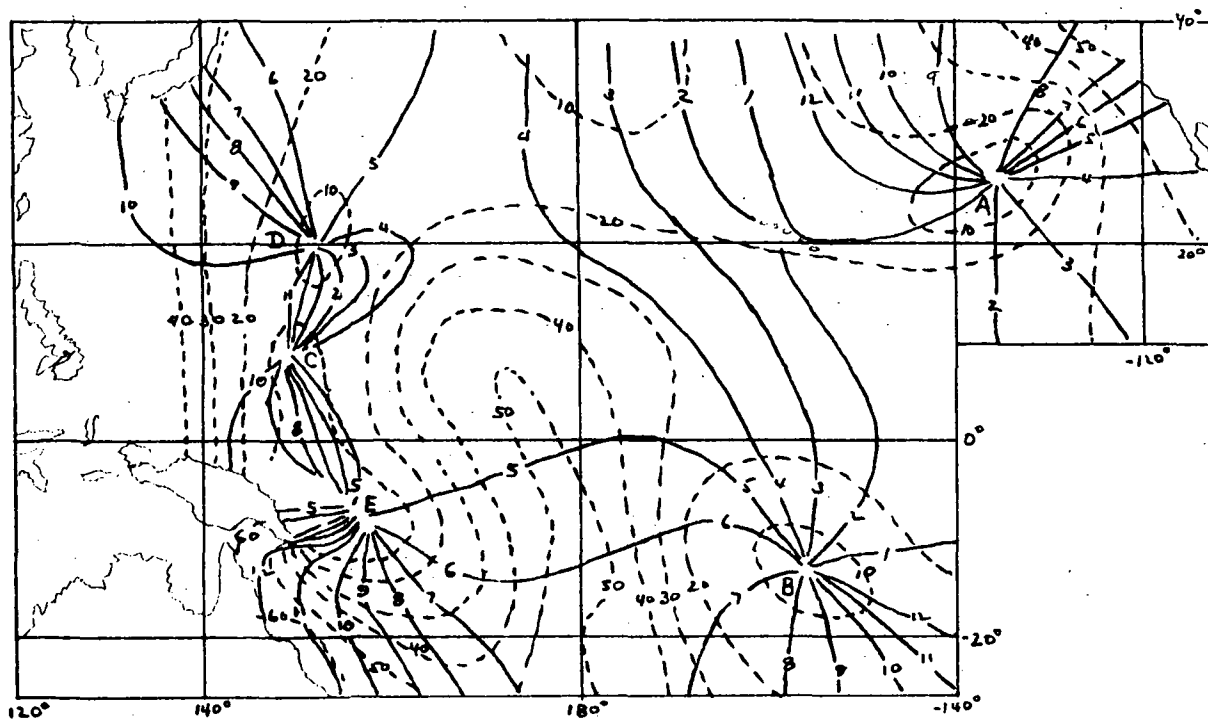
Figure 2.13  $M_2$  Amphidromic System

Radiating out from the amphidromic points are solid cotidal lines representing the phase of the tide in even hours from the high tide at Greenwich; i.e., the phase lag to high water after passage of the representative body over Greenwich (in this case, in solar hours). The dashed lines are co-range or co-amplitude values representing the tidal amplitudes in centimeters. Computational procedures for amphidromic systems are modified by boundary conditions presented by tidal data at continental coastal stations, as well as those on island systems. These coastal and island tidal data are collected

and distributed by the International Tidal Bureau at Monaco. (Tidal parameters for about 4,000 stations distributed throughout the World are included in the computer package.)

Additional authors involved in determinations of amphidromes whose works were reviewed included Cartwright et al. (1969), Defant (1961), Fairbairn (1955), Irish et al. (1971), Munk et al. (1970), Neumann and Pierson (1966), Parke (1976), Platzman (1975), Zetler et al. (1975).

A complete set of amphidromes (for all practical purposes) would include the six annual and semi-annual components given in (86). The tide for a given point and time would be given by the algebraic sum of the reduced levels. In practice, phase and amplitude values would be stored on tape for specified grid points, and extracted by using double interpolations (See Section 3.3.5).

The long-period tides ( $S_{sa}$ ,  $M_m$ ,  $M_f$ ) are treated as equilibrium tides. From Maximov (1970), the equilibrium equations are (with  $W$  in centimeters),

$$\left. \begin{aligned} H(S_{sa}) &= 0.95(1-3\sin^2\phi)\cos 2h \quad , \\ H(M_m) &= 1.08(1-3\sin^2\phi)\cos(s-p) \quad , \\ H(M_f) &= 2.05(1-3\sin^2\phi)\cos 2s \quad , \end{aligned} \right\} (189)$$

where  $H$  is the disturbance in mean-sea level,  $\phi$  is the latitude of the point and  $s$ ,  $h$  and  $p$  are defined in (183). These values, when added algebraically to those obtained from the amphidromic systems, give the total tide (See Section 3.3.5).

## 2.17 Geomagnetic Field

### 2.17.1 General Note:

The magnetic field existing at the Earth's surface and at satellite heights is made up principally of geomagnetic components. These include a combination of what is known as the dipole and non-dipole field. The dipole and lower order non-dipole (below the 7th harmonic degree) are apparently maintained by core-mantle interaction, through what has become known as the "dynamo effect"; higher-order components may include contributions of magnetic materials in the Earth's outer crust.

Solar storms and solar wind influence the Earth's magnetic field, the former, at times, inducing large field changes, but such phenomena are not preprogrammable items, and can be evaluated only from direct observation. Such considerations are beyond the scope of this preliminary EOM system and, as a consequence, effects of solar radiation have not been considered. There is, however, nothing to preclude introduction of such information if and when indicated by future studies, since the module designs have been kept open-ended.

### 2.17.2 Geomagnetic Nomenclature and Relationships:

The conventional magnetic elements are X, Y, Z, D, I, H, F; where X, Y and Z are the magnetic field intensity components (usually given in gamma units =  $10^{-5}$  Gauss) in the North, East and Down directions, respectively; D is the magnetic declination or clockwise angle of magnetic north from geographic north; I is the magnetic dip or angle below the local horizontal in the

magnetic north direction; other elements and relationships are

$$F = (X^2 + Y^2 + Z^2)^{\frac{1}{2}}$$

and

$$H = F \cos I,$$

for the total magnetic field intensity and its horizontal component, respectively. The vertical plane through the magnetic force vector,  $X_1$ , is called the local magnetic meridian. It makes the angle  $D$  with the geographic meridian. Geomagnetic coordinates, and their conversions from geographic coordinates are illustrated in Figure 2.14.

Figure 2.14 Geographic to Geomagnetic Coordinate Conversion

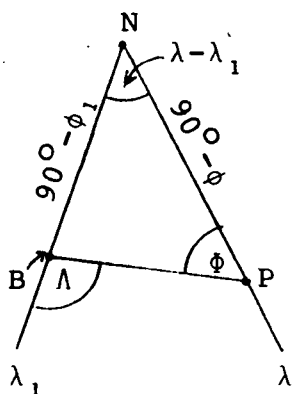

B is the magnetic pole with geographic coordinates  $\phi_1, \lambda_1$ ; P is the point with geographic coordinates  $\phi, \lambda$ . Geomagnetic coordinates are  $\Phi, \Lambda$ , and are given by

$$\Phi = \sin^{-1} \left[ \sin \phi \sin \phi_1 + \cos \phi \cos \phi_1 \cos (\lambda - \lambda_1) \right]$$

$$\Lambda = \sin^{-1} \left[ \frac{\cos \phi}{\cos \Phi} \sin (\lambda - \lambda_1) \right]$$

The geomagnetic field is conventionally represented<sup>31</sup> in spherical harmonics of the Schmidt form (See (49), (50), (53) for definition). The harmonics have the following interpretations:

<sup>31</sup> See Barraclough et al. (1975), Cain et al. (1965), (1967), Hurwitz et al. (1966), Vestine et al. (1963a), (1963b), for expressions of the geomagnetic field in spherical harmonics.

Axial dipole  $\equiv P_1$  ,  
 Equatorial dipole  $\equiv P_1^1$  ,  
 Centered dipole  $\equiv P_1, P_1^1$  ,  
 Eccentric dipole  $\equiv P_1, P_1^1, P_2, P_2^1, P_2^2$  ,  
 Non-dipole field  $\equiv P_2, P_2^1, P_2^2, P_3, \dots$  ,  
 Not considered  $\equiv P_0$  .

The magnetic elements can be developed from the negative derivative of the potential or,

$$F = -\nabla V = - \partial_i V^i$$

and

$$F_r = - \frac{\partial V}{\partial r} ,$$

$$F_\theta = - \frac{1}{r} \frac{\partial V}{\partial \theta} ,$$

$$F_\lambda = - \frac{1}{r \sin \theta} \frac{\partial V}{\partial \lambda} ,$$

$$X = - F_\theta \cos \delta - F_r \sin \delta ,$$

$$Z = F_\theta \sin \delta - F_r \cos \delta ,$$

$$Y = F_\lambda ,$$

$$\delta = \phi - \psi = \phi - \tan^{-1} [(1-e^2) \tan \phi] .$$

(190)

The potential, in spherical harmonics, is

$$V = a \sum_{n=1}^{\infty} \left(\frac{a}{r}\right)^{n+1} \sum_{m=0}^n (g_n^m \cos m\lambda + h_n^m \sin m\lambda) P_n^m(\cos \theta) . \quad (191)$$

(a=average radius vector  $\approx 6371.2$ km)

Introducing (190) into (191),

$$\begin{aligned}
 F_{\theta} &= - \sum_{n=1}^{n(\max)} \left(\frac{\rho}{r}\right)^{n+2} \sum_{m=0}^n (g_n^m \cos m\lambda + h_n^m \sin m\lambda) \frac{\partial P_n^m(\theta)}{\partial \theta} \\
 F_{\lambda} &= \sum_{n=1}^{n(\max)} \left(\frac{\rho}{r}\right)^{n+2} \sum_{m=0}^n m (g_n^m \sin m\lambda - h_n^m \cos m\lambda) P_n^m(\theta) \\
 F_r &= \sum_{n=1}^{n(\max)} \left(\frac{\rho}{r}\right)^{n+2} \sum_{m=0}^n (g_n^m \cos m\lambda + h_n^m \sin m\lambda) P_n^m(\theta)
 \end{aligned} \quad (192)$$

where  $\rho$  is given by (15) and, for points at altitude, we use (19) for  $\psi$ ;  $r = \rho + H$ , where  $H$  is the altitude of the point above sea-level. Coefficients  $g_n^m$  and  $h_n^m$  have been selected from Cain et al. (1967) and are stored in the computing package.

### 2.17.3 Geomagnetic Field:

The geomagnetic field appears to have been universally accepted<sup>32</sup> as the result of a self-exciting dynamo activated by fluid motions of the conducting liquid Earth's core, which act like a rotating disc in a disc dynamo. The mechanism is simply explained by Takeuchi et al. (1967). The element of interest is the westward drift which has been investigated by a number of scientists (See Footnote 20 on p. 64). This element was discussed in Section 2.13, and its possible influence on the Earth's rotation must be a factor in any further development of the EOM. A few comments are in order before closing out this section: The dipole is oriented at an angle to the rotation axis of

<sup>32</sup> These include Bullard et al. (1950), Bullard and Gellman (1954), Inglis (1965), Parker (1955).

$\tan^{-1} [(g_1^{12} + h_1^{12})^{1/2} / g_1]$ ; an angle of some amount is necessary according to Cowling (1957), who showed that a magnetic field symmetric about an axis could not be maintained by a symmetric motion.

Leaton et al. (1965) give the adopted positions of the north magnetic dip pole at  $\phi = 75^\circ.5N$ ,  $\lambda = 259^\circ.5E$  and the south magnetic dip pole at  $\phi = 66^\circ.5S$ ,  $\lambda = 139^\circ.4E$ ; they also give the rate of change of the dipole moment at  $(-16 \pm 2)r^3$  gamma/yr, where  $r$  is the mean radius. Bullard et al. (1950) discuss thermal convection in the core and indicate that resultant radial motions require that material near the outside of the core rotate with a lesser angular velocity than that inside, in order that angular momentum be conserved. Yukatake (1972) suggests that the angular velocity of the mantle changes with conductivity variance of the lower mantle (which is important if a small amount of leakage of the toroidal field occurs from core into mantle); he further notes that a one percent change in the dipole moment may cause a variation in Earth's rotation rate of  $5 \times 10^{-12} \text{ sec}^{-1}$ ; thus leaving open the possibility that the dipole could be a cause of short-period fluctuations in Earth's rotation, particularly so if toroidal field leakage participates in the coupling. Rochester (1960) considers the moments of inertia of core and mantle and determines that a decrease in the rate of westward drift by one-tenth of its steady-state value lengthens the day by 1.3 msec. Equations relating the westward drift have been suggested by James (1968), Nagata (1962), (1965), Rikitake (1966) and Winch (1968).



## 2.18 Gravity

Use of Earth satellites and improved observational accuracies have afforded, not only means, but reasons, for more extensive knowledge of the Earth's gravity field. The gravity field at altitude is, effectively, an upward continuation of the Earth's surface gravity. Differences between observed gravity and normal gravity (See Section 2.7), taken at ground level, are high-frequency phenomena and can be characterized only in discrete form. The situation becomes more analytic with altitude, and methods of spherical harmonics become quite effective and useful there in describing the gravity field. Zonal harmonic coefficients can be obtained from long-term orbital observations by analyzing perturbations and secular changes in orbital elements; tesseral coefficients can be determined only with precise tracking of orbital oscillations. The keys to comprehensive results are uniform distribution of observational data, a variety of satellites with appropriate orbital inclinations, provisions for properly treating atmospheric drag, and accurate and varied observational systems.

A great amount of ground gravity data has been accumulated and utilized in determining the geopotential configuration and the parameters of a best-fitting representative ellipsoid. Data holdings (1959) are given by Heiskanen and Moritz (1967), but the collection has been continuing, subject only to physical and political constraints. Procedures for utilizing ground gravimetric data for geoid determinations are

described extensively in the literature.<sup>33</sup> These data have been advantageously combined with satellite gravimetry, providing a complementary filtering effect. Results have been reported by a number of authors.<sup>34</sup>

Satellite altimetry offers a means for directly determining the ocean geoid, and thus the gravity field. Mourad (1975) reports on pending experiments, as well as the first effort on Skylab in 1973 (McGoogan et al. (1974)). Additional reports<sup>35</sup> indicate considerable promise for this method. The pelagic tides will enter into this approach in the following manner: theoretically, satellite altimetry (SEASAT) could provide means for completing the amphidromic characterizations, but the tidal influence on the satellite path could render this somewhat of a "bootstrap" operation, unless the SEASAT could be monitored to isolate these perturbations.<sup>36</sup>

Other satellite gravimetric methods are mentioned by Chovitz (1975), involving satellite-to-satellite tracking techniques (Comfort (1973) and Yionoulis and Piscane (1972)). A satellite application of gravity gradiometry is described by Forward (1973), and it is compared with other systems by Glaser

---

<sup>33</sup> See, e.g., Bomford (1971), Caputo (1967), Heiskanen and Moritz (1967), Heiskanen and Vening Meinesz (1958), Stokes (1849), Uotilla (1960), Zhongolovich (1957).

<sup>34</sup> See Caputo (1967), Cook (1963), Gaposchkin (1974), (1975), Hopkins (1972), Koch (1974), Lerch et al. (1974), Rapp (1971).

<sup>35</sup> These include Brown and Furry (1973), Lundquist and Giacaglia (1972), McCandless (1974), Weiffenbach (1972).

<sup>36</sup> See Musen and Estes (1972), Musen and Felsentreger (1973).

and Sherry (1972).

Limitations of spherical harmonic determination and validity of expression are discussed by Gaposchkin (1975). He suggests that satellite data are strong only for degrees less than 12, and spherical harmonics are probably reliable only for degrees less than 10. This is in general keeping with an empirical relationship given by Kaula (1968): the magnitude of normalized coefficients of the Earth's gravitational field up to about degree  $\ell=15$  is approximately  $10^{-5}/\ell^2$ . Despite these limitations, it was decided that the gravity field of Gaposchkin (1974), in spherical harmonics to the 18th degree and order, should be utilized to those extents in the EOM.

Spherical harmonics for gravity have traditionally been the fully normalized ones shown in Eqs. (51) through (53).

Gravity is given (for Earth-bound points) by

$$g = \frac{GM}{r^2} \sum_{n=0}^{18} (n+1) \left(\frac{\rho}{r}\right)^n \sum_{m=0}^n [\bar{C}_n^m \cos m\lambda + \bar{S}_n^m \sin m\lambda] \bar{P}_n^m - \frac{2}{3}\omega^2 r (1 - \bar{P}'_2 / \sqrt{5}) \quad , \quad (193)$$

where:

$$\rho = [a^2 \cos^2 \beta + b^2 \sin^2 \beta]^{\frac{1}{2}} = a [\cos^2 \beta + (1-e^2) \sin^2 \beta]^{\frac{1}{2}} \quad ,$$

$$\beta = \tan^{-1} \left[ (1-e^2)^{\frac{1}{2}} \tan \phi \right] + 1".71H \sin 2\phi \times 10^{-4} \quad ,$$

$$\theta = 90^\circ - \phi' \quad , \quad r = \rho + H \quad , \quad \phi' = \phi + 1".71H \sin 2\phi \times 10^{-4} \quad ;$$

a and b are the Earth's semi-major and -minor axes, respectively (a = 6378160 meters, b = 6356774.719 meters), GM is the product of the universal gravitational constant and the Earth's mass

( $GM = 3.986010 \times 10^{14} \text{ m}^3\text{sec}^{-2}$ ),  $(\rho, \beta, \lambda)$  are the ellipsoidal coordinates of the point,  $\phi$  and  $\lambda$  are the latitude and longitude of the point, respectively,  $\bar{C}_n^m$  and  $\bar{S}_n^m$  are normalized harmonic coefficients,  $H$  is the altitude of the point in meters,  $\bar{P}_n^m$  are fully normalized Legendre polynomials,  $\omega$  is the Earth's rotation rate ( $\omega = 7.292105 \times 10^{-5} \text{ sec}^{-1}$ ). For satellite points, the right-hand term in (193) is disregarded, and  $GM = 3.986013 \times 10^{14} \text{ m}^3\text{sec}^{-2}$  to include the atmosphere.

## Chapter 3

### EARTH AND OCEAN MODULES

#### 3.1 General Design

Each modular component of the EOM has the facility for ready update when it is desired to change or increment the system. The main program is known as the Input-Output program (IOP), and is the place where the user selects a particular operational mode, introduces data to be processed, and necessary input-output coordinate transformations are made. Details of mode selection are given in Section 3.2.

All constants and other parameters which apply to individual geophysical modules are put into Common statements where possible; data changes are made in the modules where they are introduced. A description is made in each of the sections giving geophysical module details (Sections 3.3.1 through 3.3.8) of each parameter identification code and its location.

In principle, the IOP would have a direct tie to each geophysical module (GM) as shown in the block diagram in Figure 3.1, and in the flow diagrams in Figure 3.2. It was decided, however, for convenience, to tie only four of the modules to an IOP, and to maintain the remaining four as individual units. Factors bearing on this decision are discussed in Sections 3.2 and 3.3.

Figure 3.1 Block Diagram of EOM

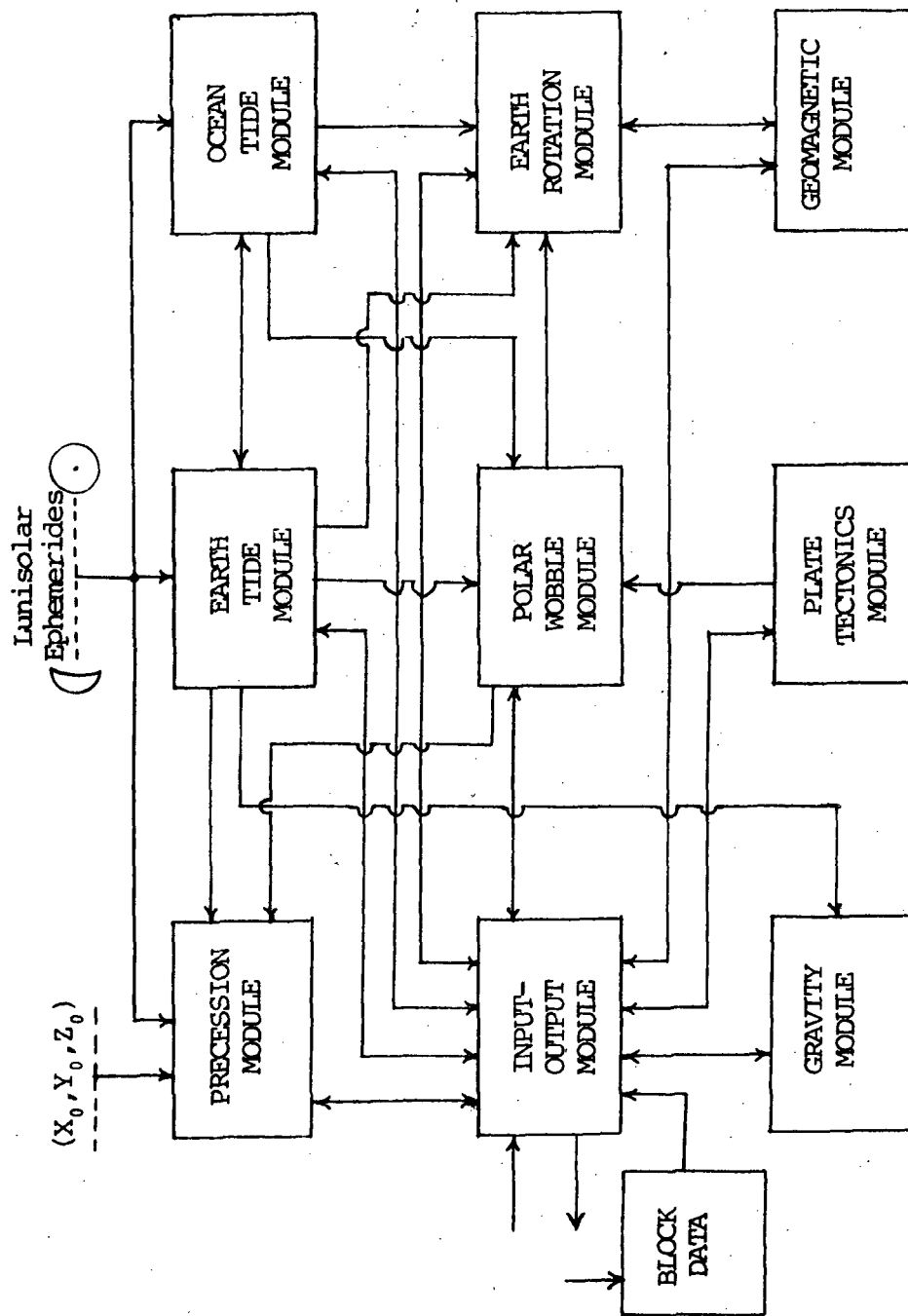

Figure 3.2 Flow Diagrams

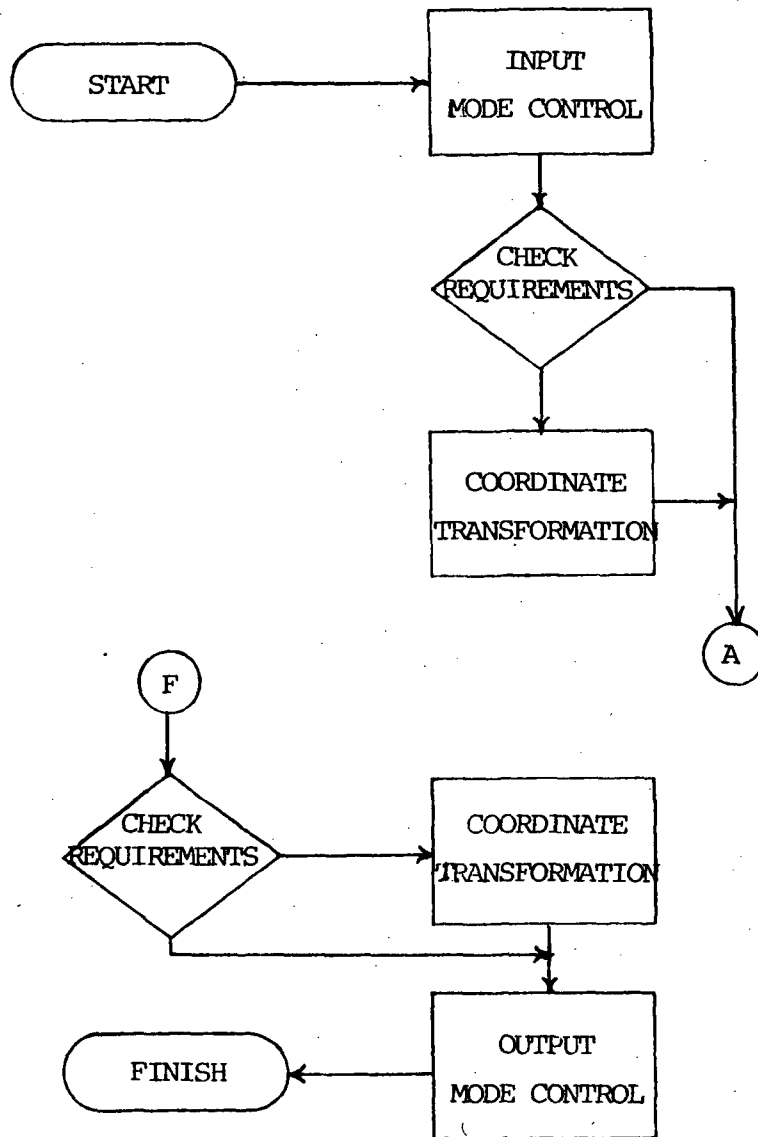

Figure 3.2 Flow Diagrams (Continued)

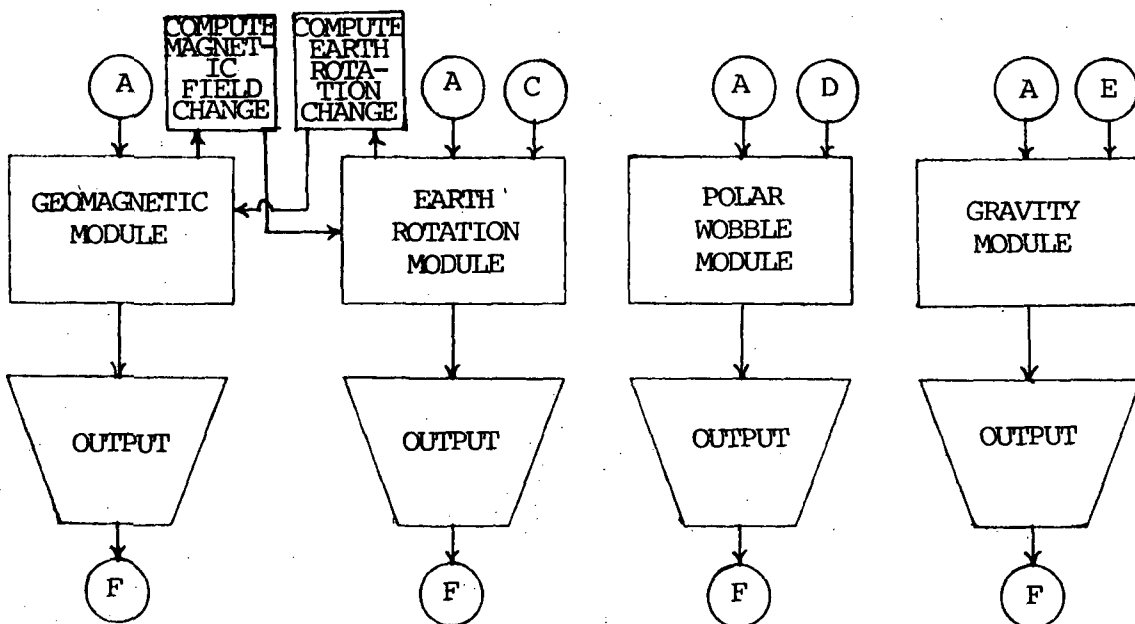
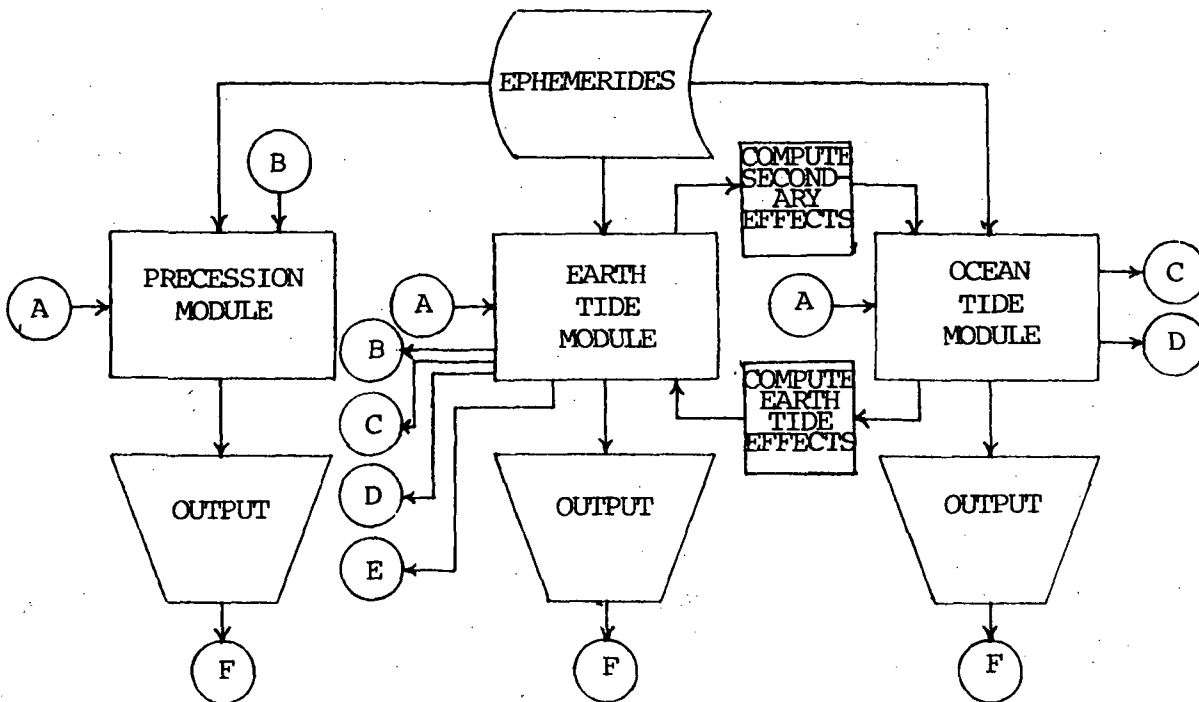
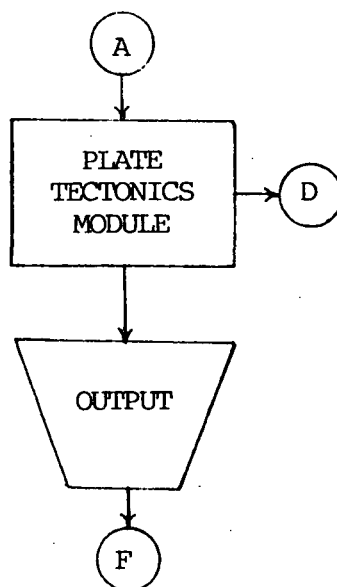



Figure 3.2 Flow Diagrams (Continued)





---

In Figure 3.1, the  $(X_i)_0$  input to the precession module defines the epoch of choice for the inertial reference system; inter-module data flow is shown by two-way and one-way symbolism. The first two diagrams in Figure 3.2 show the input and output stages, respectively; interfacing points (A) and (F) are keyed to all GM programs. Direct data exchange, not involving the IOP, are for interface points (B) through (E), respectively. Inter-module operations requiring iterative interactions are shown in the third and fourth diagrams in Figure 3.2.

### 3.2 Input-Output Modes

The flow diagram of the system of four modules tied into

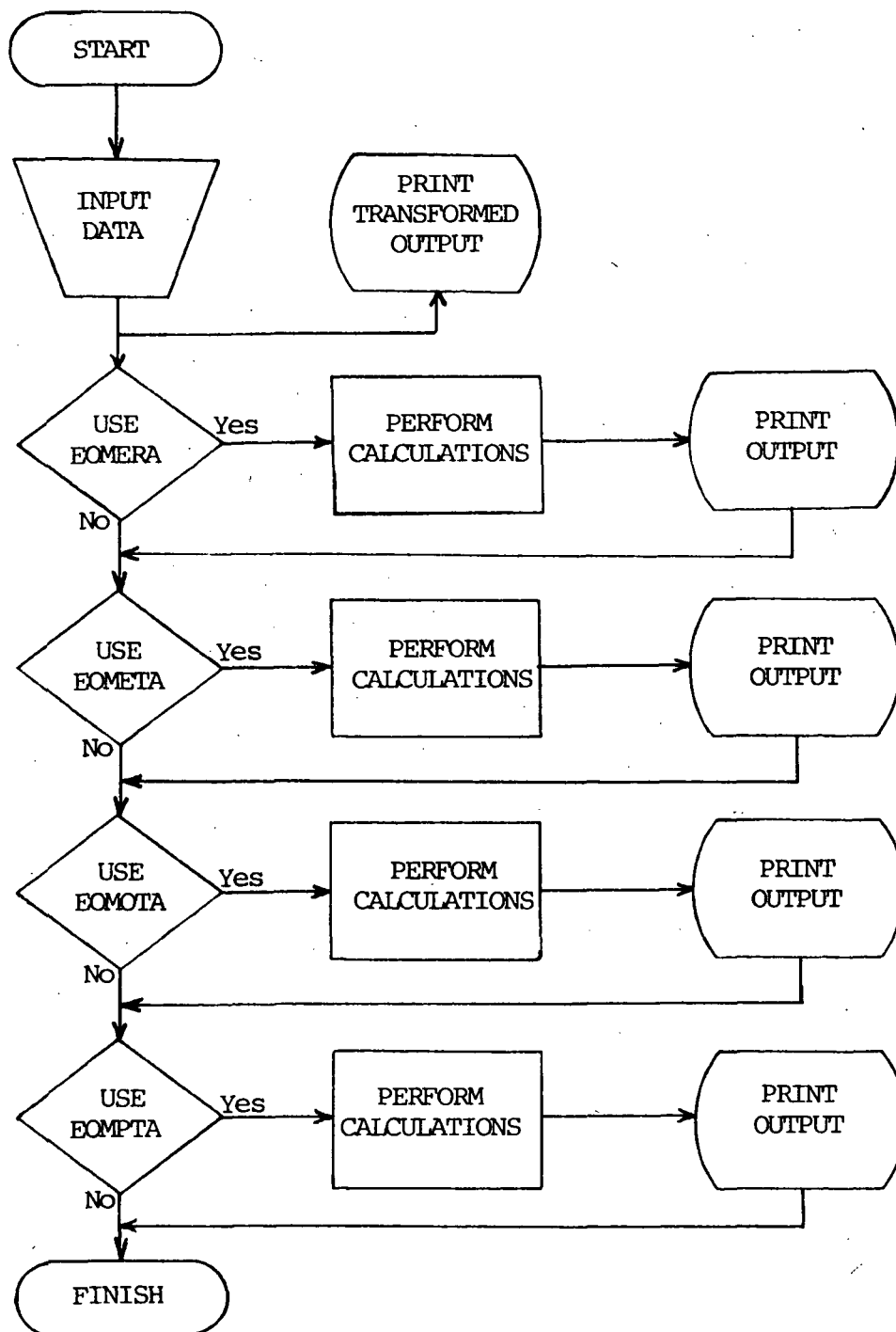
Figure 3.3 Flow Diagram of Four-Module System



the IOM is shown in Figure 3.3. The system is designed to accept station coordinates in either rectangular geocentric (metric units) or geodetic (sexagesimal format) with elevations in meters. Output, for all cases, is in the geodetic format. Additional options can be readily introduced, but it is felt that for such isolated cases as might occur, the simplest procedure would be to transform them in a separate program. The probability of using the geomagnetic field and gravity modules exclusively for certain operations led to the decision to keep these separate and intact; they are not directly related to the IOM, but the IOM can be used to convert rectangular coordinates to the required geodetic values for the modules. The conversion system built into the IOM can be reproduced for either, or both, of these latter two modules.

The precession module has little relationship with other modules, and its complexity and time-consuming computational characteristics indicates a separate role as the best practice.

The polar wobble module requires an elaborate update procedure which makes its integration with other modules an impracticable concept. Specifics are discussed in detail in Sections 3.3.2 and 5.2.

Input data and updating procedures are discussed in the individual GM sections.

### 3.3 Geophysical Module Details

#### 3.3.1 Precession Module:

The precession module (EOMPMA) includes 11 subroutines in the calling sequence indicated in Figure 3.4. Data and

Figure 3.4 EOMPMA Subroutine Calling Sequence

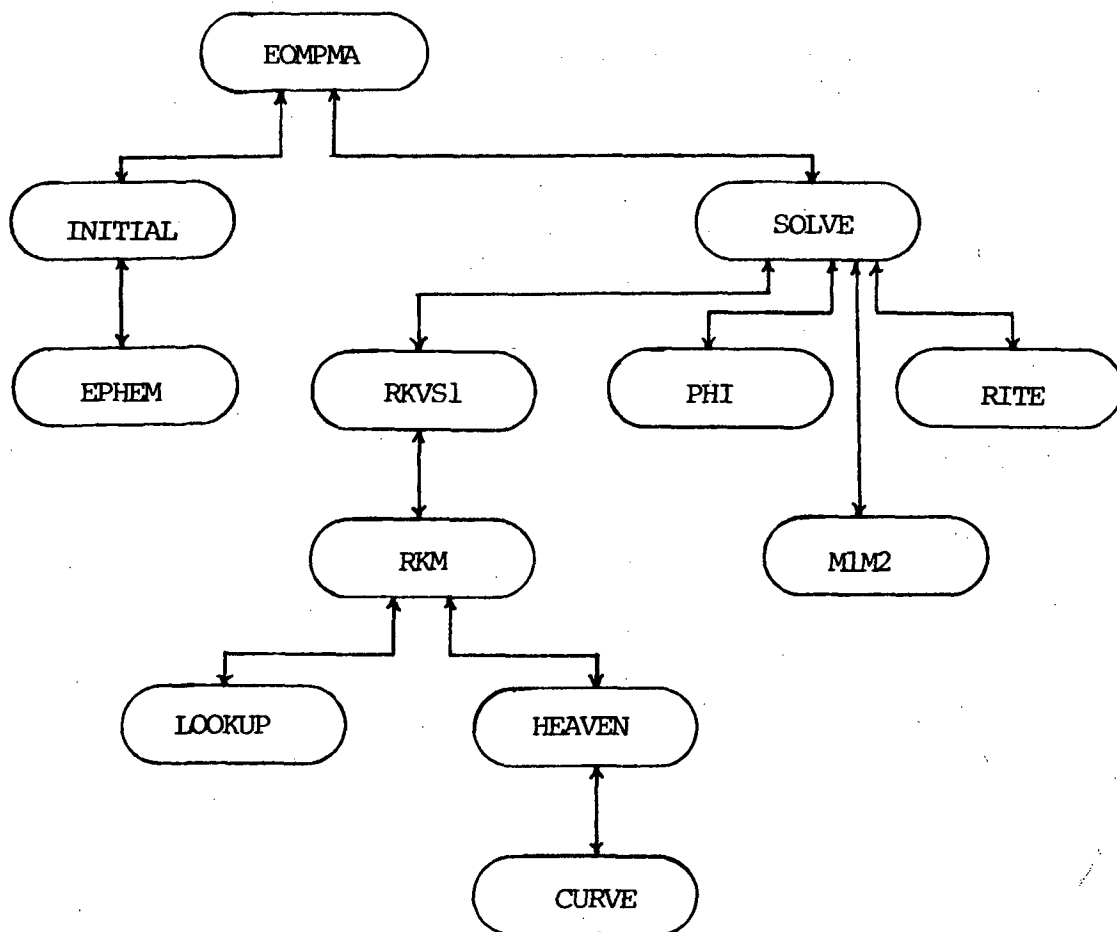

parameters are located as follows:

EOMPMA Function is Main; no data.

INITIAL Accepts read-in data. These include:

NPRT = Number of print intervals;  
 IEPOCH = Epoch of astronomical constants. It is either 1900 or 1950 (Default). (In Format 502 card, a non-zero element in column 10 calls for 1900.)  
 TSTART = Julian starting date.  
 DELP = Print intervals.  
 TP = Print interval cutoffs.  
 AO(1) = Initial Theta value (in radians) for TSTART.  
 AO(2) = Initial Psi value (in radians) for TSTART.  
 AO(3) = (Leave blank).  
 XMO(I) = (Leave blank).  
 CM = Polar moment of inertia.  
 AM = Equatorial moment of inertia.  
 RR = Adopted constant for Earth's rotation.  
 AA = Earth's semi-major axis.  
 GK = Gravitational constant.  
 XMASS(1) = Sun's mass.  
 XMASS(2) = Moon's mass.

(These cards are punched and located in data section. All above data preceding CM must be updated for user's option. Item CM and those following may be kept at the user's option.)

BLOCK DATA Not a subroutine. Contains data not subject to change.

EPHEM Parameter NTPP = 366 indicates maximum number of days permissible for a run. Routine reads ephemeris data. These data are those provided by the US Naval Observatory converted into EOM format. (Coverage: 1970 - 1980.)

SOLVE Coordinating program for data interpolations, integrations, and associated computations. No variable data.

RKVS1 Integrating routine. No variable data.

RKM, LOOKUP, HEAVEN, CURVE Concerned with interpolation and application of ephemeris data. No variable data.

PHI, M1M2 These are used to calculate the Euler angle Phi and the direction cosines, respectively. Direction cosines indicate diurnal motion of the pole. No variable data.

RITE Controls the output printout. No variable data.

Program outputs are the Euler angles relating the ecliptic of 1950.0 to the Earth's axis of figure, and the diurnal luni-solar axis motion in arc seconds.

### 3.3.2 Polar Wobble Module:

The polar wobble module is a single program which develops a simulated model of the polar coordinates at mid-monthly points. Data are output in punched card form as well as in print. Simulation is a curve fitting technique using the equation,

$$m_i = m_0 e^{i\sigma t_i} + \frac{\sigma \psi_a^+}{\sigma - 2\pi} e^{i2\pi t_i} + \frac{\sigma \psi_a^-}{\sigma + 2\pi} e^{-i2\pi t_i} + \frac{\sigma \psi_{sa}^+}{\sigma - 4\pi} e^{i4\pi t_i} + \frac{\sigma \psi_{sa}^-}{\sigma + 4\pi} e^{-i4\pi t_i} + S t_i + \sum_{k=1}^m J_k (1 - e^{i\sigma(t_i - \tau_k)}) \quad , \quad (194)$$

where all quantities are complex except for  $t_i$ ;  $m_i$  are the polar coordinates;  $m_0$  are the initial coordinates at time  $t_0$ ;  $\psi^\pm$  are excitation functions (with subscript a and sa referring to annual and semi-annual, respectively);  $\sigma$  is the adopted value of the Chandler frequency (taken here as  $5.3(1+0.01i)$ );  $S$  is the secular drift in the pole;  $J_k$  are Heaviside step functions introduced at times,  $\tau_k$ , and  $m$  is the number of step functions. Step functions and other elements of Eq. (194) are obtained from supplementary programs and operations as follows:

Polar motion data of the IPMS and ILS are not provided at convenient equal time intervals which are necessary for Fourier analysis. These are converted using WBBLCONV, an

adaptation of a cubic spline curve fit. Output is in punched cards as well as in print.

Transformation from the time to frequency domain and return is through use of a Fast Fourier Transform (FFT) program called FOURT. Utilizing FOURT as a subroutine to programs POWER, REVTRFM AND SPECTRUM, we obtain the following:

POWER provides the power spectrum of the polar wobble time series. The annual and semi-annual power contributions are noted and reduced to the average levels in those frequency regions.

REVTRFM returns the frequencies with adjusted powers to the appropriate time series. This provides polar wobble data with annual and semi-annual effects removed. Both POWER and REVTRFM outputs are in punched cards as well as in print.

SPECTRUM is, in general, the same as POWER with some modifications including Hanning and a logarithmic power output. Output is in punched cards as well as in print.

ATMOSPH calculates the annual and semi-annual excitation functions from the REVTRFM output, for various Chandler frequencies and dissipation function values. It also calculates the annual effects in terms of X and Y components. Output is in print.

SUBATMO removes the determined annual and semi-annual excitations from any polar wobble time series. Output is in punched cards as well as in print.

CWBLANALY and CWBLANALY2 are used to determine the

magnitudes and directions of the step functions required to duplicate the actual polar motion. CWBANALY is used for the initial investigation; when a number of step functions have been determined, further operations must be through CWBANALY2. The procedure is to determine the points in time which mark the limits of a series of points which are generally equidistant along a smooth arc, for each particular section. These times are introduced into the program, and corresponding complex step values are determined. (Note: When continuing with a subsequent series, the last two or so previously determined step values should be discarded. The action to take will be quite obvious from the punched or printed output.)

CORRPLOT is used to determine the mean position of the pole for given periods over the extent of the polar motion time series. Output is in print.

### 3.3.3 Earth Rotation Module:

The Earth rotation module is the first option of the IOM routine. The input procedure is the same for all four and is as follows:

The name of the multi-program is EOMIO. The first data card is in Format 502 and takes the values:

NLC = Number of stations.  
NTI = Number of intervals.  
DELP = Spacing between intervals (time)  
TSTART = Starting time (Julian date with a decimal equal to .5; i.e., a UT = 0 hours.)



PEPOCH = Epoch for the plate tectonics calculation given in Julian date.

BIHIO = Tabular value of UT2-TAI taken from BIH smoothed data (pink sheets in the annual report) for the TSTART value. When only the Earth's rotation data is required, the value of DELP should be taken as 5.0. Note, also, that TSTART should be a multiple of 5 for most convenience in using this section in an individual mode.

SECROT = Secular variation of UT2-TAI determined from the most recent smoothed BIH extended series.

MNU(I) are default options for introducing or excluding one or more of the IOM modules. A non-zero quantity in columns 73,74,75,76 introduces EOMERA, EOMETA, EOMOTA, EOMPTA, respectively, into operation.

The second and subsequent (1 through NLC) cards are station description cards. The first element (column 1) defines the type of coordinates. A "1" indicates rectangular geocentric coordinates. Any other option indicates geodetic (sexagesimal) coordinates. After the option is noted, the card is read in its entirety in an appropriate program section. Data read, in turn, are:

ICO = Coordinate option.

LOC = Station name.

(Coordinates) = Either X,Y,Z (option "1") or latitude, longitude and elevation (default option). (H is the elevation.)

ITPN = Tectonic plate number.

The Earth rotation module parameters and constants are considered firm and should be corrected only as provided in the EOMIO input.

### 3.3.4 Earth Tide Module:

The Earth tide module includes 6 subroutines in the calling sequence indicated in Figure 3.5. Functions are similar to those subroutines of EOMPMA of like name. HEAVER is analogous to HEAVEN, etc., with the function of RITE being assigned to EOMETA. Constants are fairly well established within these,

Figure 3.5 EOMETA Subroutine Calling Sequence

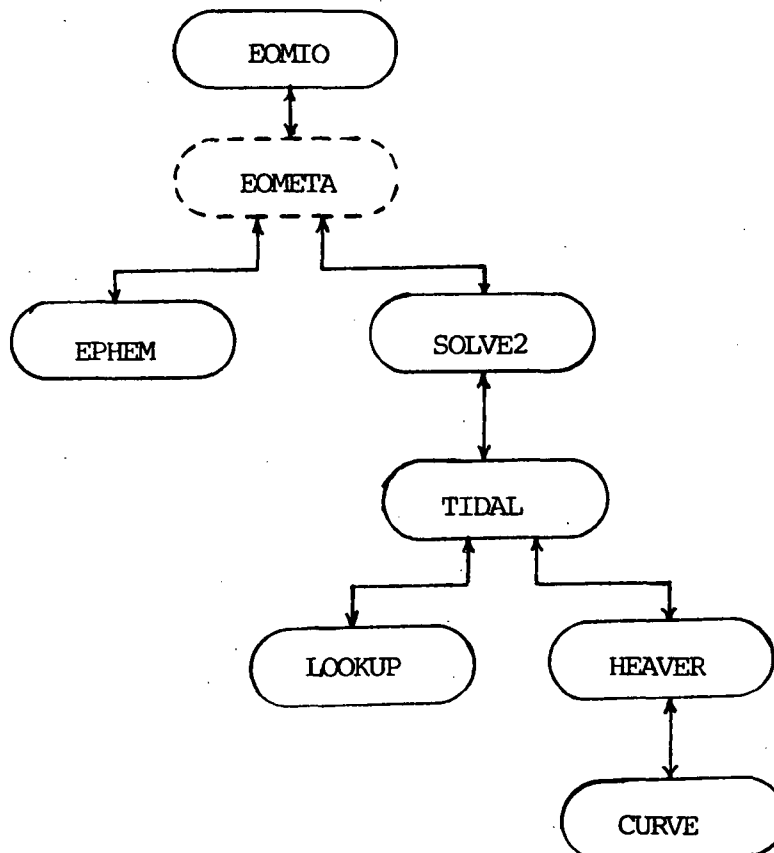

except for  $XLH = 0.59$ ,  $XK = 0.29$ ,  $XLL = 0.07$ , which are the Love numbers  $h$ ,  $k$ ,  $l$ , respectively, which the user may care to vary.

### 3.3.5 Ocean Tide Module

The ocean tide module is, of necessity, incomplete until amphidromic data for all six principal (semi-diurnal

and diurnal) tides become available. Presently we have incorporated a preliminary set of  $M_2$  amphidromic data to set the procedure for future availability of these data. The procedure for expanding the system is quite obvious from the format. The procedure for defining data points is through use of a rectangular mercator system of  $6^\circ$  grid intervals. The system has a Northing of  $102^\circ$ , a Southing of  $-120^\circ$ , an Easting of  $282^\circ$  and a Westing of  $-72^\circ$ . There will be a total of 2280 points for which phase angles and amplitudes are given. Conversion of geodetic coordinates to this system are given by

$$N_m = \ln(\cot(45^\circ - \frac{1}{2}\phi)) \frac{180}{\pi} \quad , \quad (195)$$

$$E_m = \lambda - 180^\circ \quad , \quad (196)$$

where  $\phi$ ,  $\lambda$  are the geodetic coordinates with the additional provision that  $\lambda$  is taken as positive from  $0^\circ$  to  $360^\circ$ .

Constants are fairly firm with the exception of values  $V_1(I)$ , which are amplitudes for the  $S_a$ ,  $S_{sa}$ ,  $M_m$  and  $M_f$  long period tides (in mm), which may be varied at the discretion of the user.

### 3.3.6 Plate Tectonics Module:

The plate tectonics module constants for plate motions are not considered firm, but they are fairly representative. These rotation parameters are given as  $W(I,J)$ , in units of  $10^{-7}$  deg/yr, and are identified by number in Table 2.4.

### 3.3.7 Geomagnetic Module:

The geomagnetic field module EOMMFA treats the field in terms of spherical harmonics using coefficients developed by Cain et al. (1967). The input data are:

LOC = Station name.

PHI = Latitude (degrees and decimal.)

XLAM = Longitude (degrees and decimal.)

H = Elevation in meters.

MAXN = 10 = Maximum degree of harmonics used. This may be taken as less if desired.

LFN = Type of Legendre polynomial. For EOMMFA this is type 3 (Schmidt partially normalized form).

IHAR = Option for ellipsoidal harmonics. Leave blank.

NEWAB = Default option. First station card carries a "1"; is followed by the harmonic coefficients, and these are followed by remaining station data cards with NEWAB blank.

Outputs are the magnetic field parameters described in Section 2.17.2.

### 3.3.8 Gravity Module:

The gravity module uses spherical harmonics, with coefficients developed by Gaposchkin (1974). Input data for EOMGMA is the same as for EOMMFA except that MAXN = 18, IHAR = 4 (fully normalized form), and there is no default option. Outputs are the gravity at the indicated altitude in two forms: G, which is the gravity of a body rotating with the Earth, and, GP, which is the gravity for a body independent of the Earth's rotation.

## Chapter 4

### APPLICATIONS OF THE EARTH AND OCEAN MODEL

#### 4.1 General Note on Applications

There are several areas where in-depth studies of geophysical phenomena can be advantageously conducted using the EOM format; however, the complexity of Earth and ocean dynamics preclude, or at least, inhibit, an effective predictive application. Data measurements made with already achieved high precisions provide a wealth of material for evaluation of cause and effect. Areas of best application are Earth's rotation and polar motion, the geomagnetic and gravity fields, and the pelagic tides.

Effective time services provided by the BIH and improved timing and rotation monitoring systems can be correlated with atmospheric and other disturbing sources to develop more precise estimates of secular and aperiodic time changes. SEASAT provides an excellent opportunity to establish the pelagic tidal components in an empirical rather than the presently employed, theoretical, but unnatural procedure.

There appears to be a less than coincidental relationship between the drift of the geomagnetic field and variation of the Earth's rotation rate. Correlations could be detected and exploited through an EOM application.

Polar motion studies can be effectively made using the EOM and some work was done in this area while conducting this

study. The purpose was to test an hypothesis advanced by Smylie and Mansinha (1968), and others, that the irregular and large variations of the polar path from its theoretically proper trace were due to readjustments of Earth's mass associated with large earthquakes. The report of this investigation is given in the following section.

#### 4.2 Polar Wobble Study

Details of polar wobble have been given somewhat extensively in Section 2.14 and will not be repeated here. The polar motion is mathematically described in Eq. (194), and, given enough Heaviside step functions, any polar path can be faithfully reproduced. The problem lies in assigning causes for these steps, to the amplitudes and frequencies (of occurrence) necessary for the fitting configuration.

The atmospheric influence was rather thoroughly tested by Wilson (1975) and considered inadequate as the motive force. A number of authors have utilized Fourier techniques to determine the atmospheric influence. The consensus was that it was a highly predictable phenomenon with a remarkably constant annual (and to a lesser degree, semi-annual) period, but not sufficient to cause the observed effects.

An alternative has always been to assume errors in the astronomic observations and reductions; however, the ILS observations conducted under rather stringent conditions over a period exceeding 75 years, have exhibited internal consistencies not warranting the noted excursions. The ILS procedure

to utilize the same stars at all stations for their observing program precluded significance of systematic star position errors. Some systematic error problems still existed, primarily that of evaluating instrumental constants. In the last two decades, the BIH has made a significant contribution to polar motion monitoring. More recently, doppler observations on artificial satellites (by the DPMS) have provided polar motion data, and these are combined with the BIH in their reports. Although ILS data is not completely consistent with BIH data, they exhibit the same trends, and the indication is that some factor other than observation error is involved.

The only remaining "culprit" would be some fairly sudden changes in distribution of Earth's mass; possibly signalled by a large earthquake. This logical premise has been investigated by geophysicists and seismologists with varying results. The problem hinges on finding enough mass shift to cause the looked-for results. The consensus is that phenomena associated with earthquakes are insufficient by a factor of about 10 to account for the polar wobble transients.

In connection with the EOM development, a test was made to determine whether an approximation to the polar wobble could be developed assuming that influences took effect only at times of very large earthquakes. Earthquakes and their dates were taken from O'Connell and Dziewonski (1976) and involved 30 events from 1901 through 1964. Magnitudes were 8.4 or larger on the Richter scale. Using a program called

WBLSMOOTHXY, at earthquake times, the Heaviside step values were determined to best fit ILS data (corrected for atmospheric effect) by a smooth spiral (exponentially decaying due to a dissipation factor of 50) joining fixed points. Values of the determined Heaviside step values are shown with other data in Table 4.1. The program output included a new set of polar data points which, when plotted, were reasonably consistent with plotted ILS values

The average earthquake effects (shifts in the center of rotation of polar axis from one earthquake to the next) are 11.9 in X and 12.9 in Y (Units are  $10^{-8}$  radians) or a diagonal value of 17.5, or 36 msec of arc. Values determined by O'Connell and Dziewonski averaged to 19 msec of arc. The determination was within a factor of 2 of the seismologists' estimate, well within the uncertainty of their deductions. There was no correlation between direction of step values, but their estimates were developed from rather uncertain projections to subsurface faultings. Comparisons of ILS and the simulated earthquake traces are shown in Figures 4.1 through 4.3 and are representative of the group. The units in the figures are  $10^{-8}$  radians.

The conclusion which might be drawn from this experiment is that it is quite possible that the source, inducing variations in radii of the polar motion trace, may be mass redistributions in the Earth signalled by very large earthquakes.



Table 4.1 Earthquake Induced Polar Wobble Steps

Earthquake Interval		Mean Polar Coordinates		Earthquake Effects	
From	To	X	Y	X	Y
1901.71	1902.79	3.3	2.2	1.9	-14.3
1902.79	1905.29	5.2	-12.2	2.1	-4.1
1905.29	1906.12	7.4	-16.4	-9.6	-12.7
1906.12	1906.62	-2.3	-29.0	15.4	18.5
1906.62	1910.46	13.1	-10.5	-2.2	10.7
1910.46	1911.46	10.9	0.2	8.4	-27.2
1911.46	1914.96	19.3	-27.1	2.4	-0.6
1914.96	1917.46	21.7	-27.7	-12.6	8.0
1917.46	1919.38	9.0	-19.7	11.1	-6.0
1919.38	1923.04	20.2	-25.7	14.0	13.8
1923.04	1929.21	34.1	-12.0	-42.2	-38.4
1929.21	1934.04	-8.1	-50.4	25.5	-29.7
1934.04	1938.88	17.4	-80.0	-0.6	9.8
1938.88	1940.04	16.8	-70.2	-2.0	-2.0
1940.04	1940.46	14.8	-72.1	6.1	12.0
1940.46	1941.54	20.9	-60.1	30.6	16.5
1941.54	1941.96	51.5	-43.6	-20.7	-11.0
1941.96	1942.71	30.8	-54.6	14.3	-5.4
1942.71	1947.04	45.1	-60.7	-27.5	-22.6
1947.04	1950.62	17.5	-82.7	21.5	-2.3
1950.62	1952.21	39.0	-85.0	6.7	13.7
1952.21	1952.88	45.7	-71.2	11.7	-12.0
1952.88	1958.88	34.0	-83.2	-2.5	5.6
1958.88	1960.46	31.5	-77.6	-4.5	-17.6
1960.46	1964.29	27.0	-95.3	2.3	7.9
1964.29	1975.96	29.2	-103.1	(No quake during this period)	

Units are  $10^{-8}$  radians.

Figure 4.1 Polar Wobble Plot 1

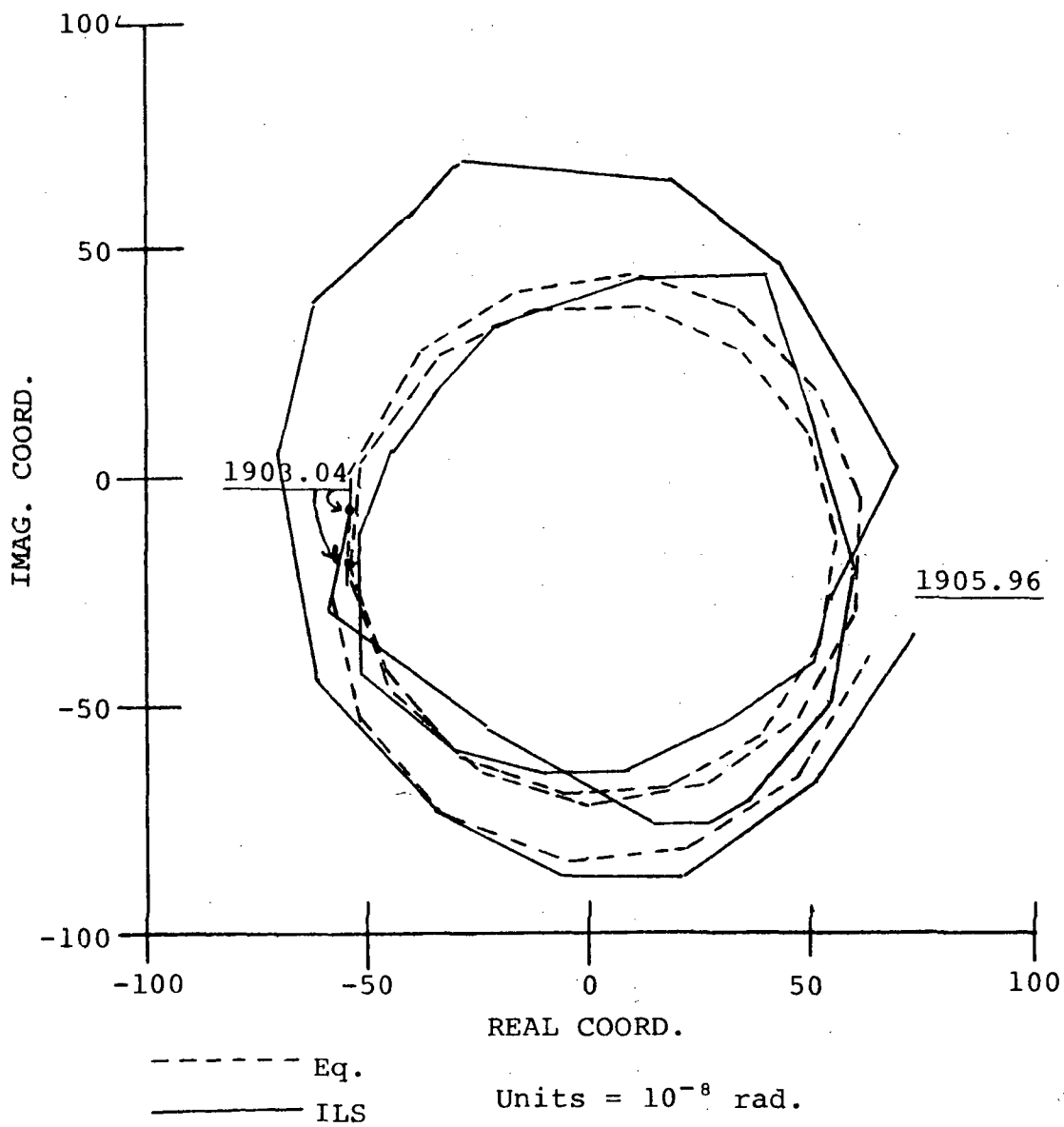

Figure 4.2 Polar Wobble Plot 2

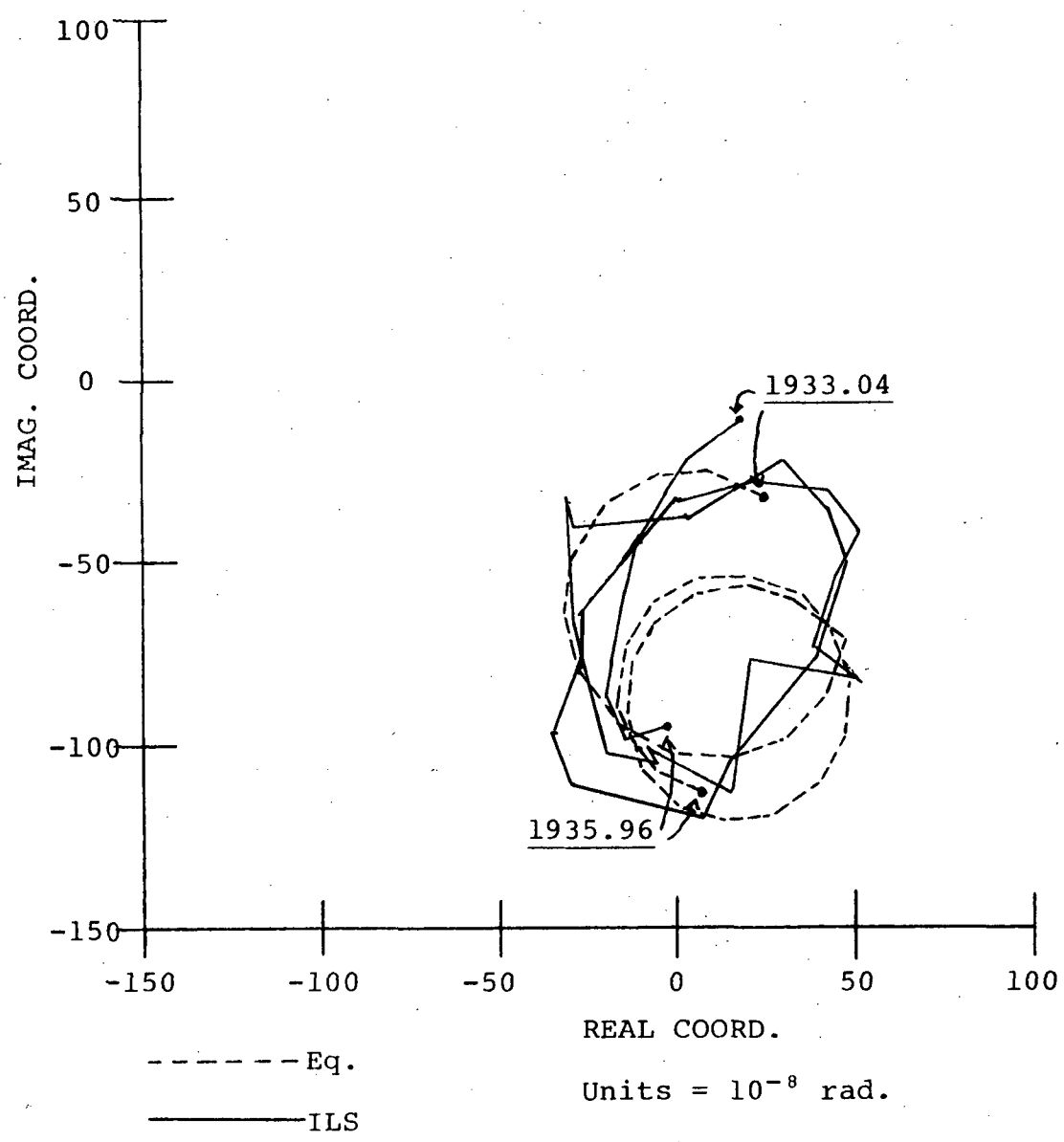
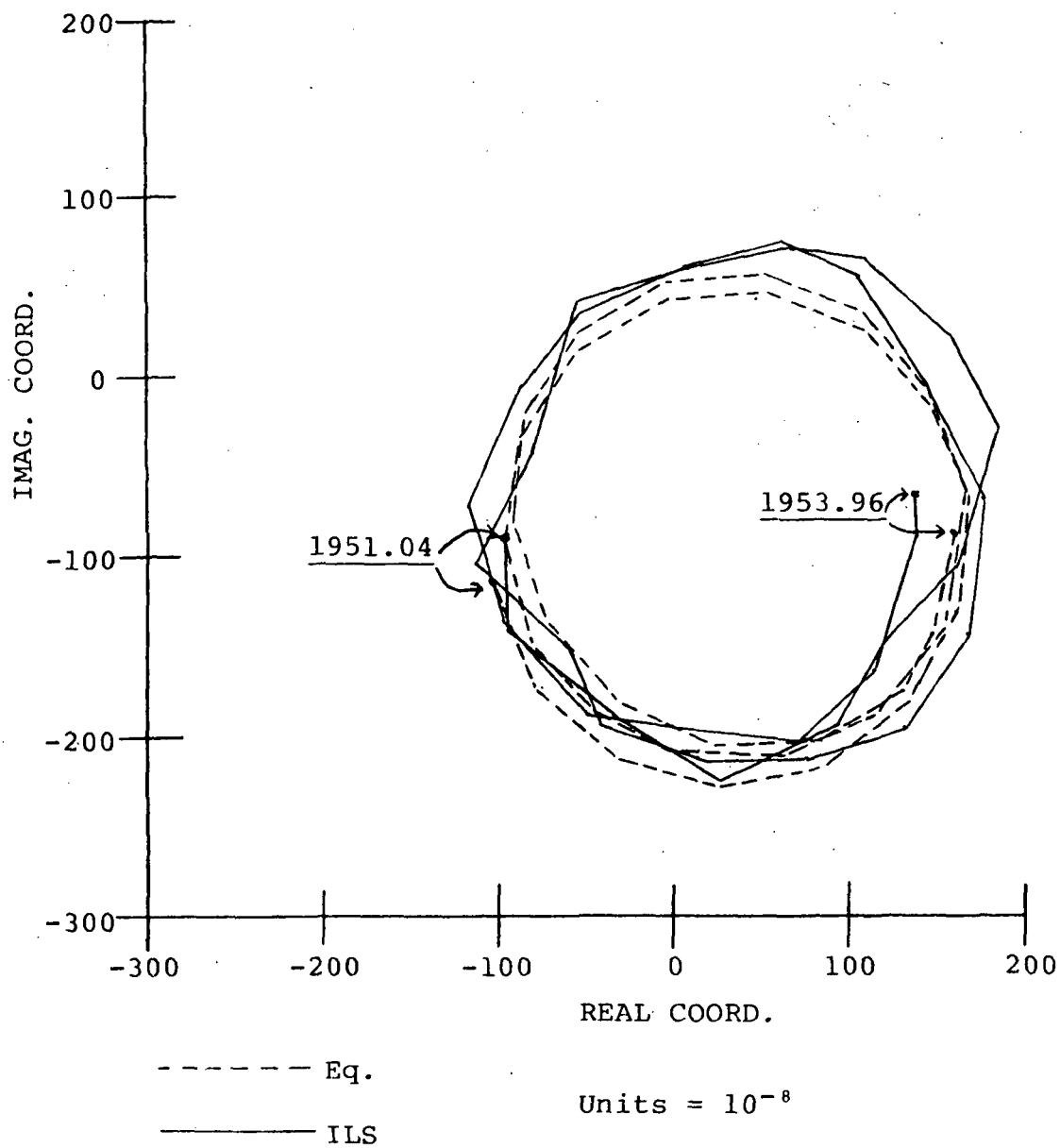

Figure 4.3 Polar Wobble Plot 3



## Chapter 5

### SUMMARY OF THE EARTH AND OCEAN MODELING PROGRAM

The EOM in its present state is a first-order approach to a geophysical model of the Earth's dynamics. Period of effort was inadequate to effectively exploit interactions between, for example, the ocean and Earth tides; i.e., the secondary effect of the ocean tide. The text of the report provides a fairly concise, yet reasonably complete overview, of the problems involved in Earth and ocean modeling. The programs should be checked more completely than was possible in the allotted contract time. It should certainly be continued and adapted to some active experimental roles.

Programs and data are on magnetic tape. In addition, listings, with sample data inputs, are provided for the convenience of the user. Approximately 4,000 tidal stations (data from the International Hydrographic Office at Monaco) are in punched card form. These could be applied as boundary conditions in the event that it was decided to investigate amphidromic systems.

## REFERENCES

- Alsop, L.E. and J.T. Kuo, 1964, "The Characteristic Numbers of Semi-Diurnal Earth Tidal Components for Various Earth Models:", *Anales de Geophysique*, 20, 286.
- Anderle, R.J., 1973, "Determination of Polar Motion from Satellite Observations", *Geophys. Surveys*, 1, 147.
- Anderle, R.J., 1975, "Error Model for Geodetic Positions Derived from Doppler Satellite Observations", Rpt. NSWC/DL TR-3368, Naval Surface Weapons Center.
- Aoki, S., 1969, "Friction between Mantle and Core as a Cause of the Secular Change in Obliquity", *Astron. J.*, 74, 284.
- Arur, M.G. and I.I. Mueller, 1971, "Latitude Observations and the Detection of Continental Drift", *J. Geophys. Res.*, 76, 2071.
- Awade, S.T., G.C. Asnani and R.N. Keshavamurty, 1975, "Spherical Harmonic Analysis of the Normal Constant Pressure Charts in the Northern Hemisphere", *Arch. Met. Geoph. Biokl., Ser. A*, 24, 189.
- Barazangi, M. and J. Dorman, 1969, "World Seismicity Maps Compiled from ESSA, Coast and Geodetic Survey, Epicenter Data, 1961-1967", *Bull. Seismol. Soc. Amer.*, 59, 369.
- Barraclough, D.R., J.M. Harwood, B.R. Leaton and S.R.C. Malin, 1975, "A Model of the Geomagnetic Field at Epoch 1975", *Geophys. J. R. astr. Soc.*, 43, 645.
- Beavan, R.J., 1974, "Some Calculations of Ocean Loading Strain Tides in Great Britain", *Geophys. J. R. astr. Soc.*, 38, 63.
- Ben-Menahem, A. and M. Israel, 1970, "Effect of Major Seismic Events on the Rotation of the Earth", *Geophys. J. R. astr. Soc.*, 19, 367.
- Beuglass, L.K. and R.J. Anderle, 1972, "Refined Doppler Satellite Determinations of the Earth's Polar Motion", *Geophys. Monograph Series*, American Geophysical Union, 15, 181.

- Bomford, G., 1971, Geodesy, 3rd Ed., Clarendon Press, London.
- Bondi, H. and R.A. Lyttleton, 1948, "On the Dynamical Theory of the Rotation of the Earth - I. The Secular Retardation of the Core", Proc. Cambridge Phil. Soc., 44, 345.
- Bondi, H. and R.A. Lyttleton, 1953, "On the Dynamical Theory of the Rotation of the Earth - II. The Effect of Precession on the Motion of the Liquid Core", Proc. Cambridge Phil. Soc., 49, 498.
- Brouwer, D., 1952, "A New Discussion of the Changes in the Earth's Rate of Rotation", Proc. Nat. Acad. Sci., 38, 1.
- Brown, R.D. and R.J. Furry, 1973, "Determination of the Geoid from Altimetry Data", Rpt. 5035-2100-21TM, Computer Science Corp., Falls Church, Va.
- Bullard, E. and H. Gellman, 1954, "Homogeneous Dynamos and Terrestrial Magnetism", Phil. Trans. Roy. Soc. London, A, 247, 213.
- Bullard, E.C., C. Freedman, H. Gellman and J. Nixon, 1950, "The Westward Drift of the Earth's Magnetic Field", Trans. London Phil. Soc., AM, 243, 67.
- Bullen, K.E., 1963, An Introduction to the Theory of Seismology, 3rd Ed., Cambridge University Press, London.
- Burke, K. and J.T. Wilson, 1972, "Is the African Plate Stationary", Nature, 239, 387.
- Cain, J.C., W.E. Daniels, S.J. Hendricks and D.C. Jensen, 1965, "An Evaluation of the Mean Geomagnetic Field, 1940-1962", J. Geophys. Res., 70, 3647.
- Cain, J.C., S.J. Hendricks, R.A. Langel and W.V. Hudson, 1967, "A Proposed Model for the International Geomagnetic Reference Field - 1965", J. Geomag. Geoelectr. 19, 335.
- Capitaine, N., 1975, "Total Effect of any Nearly-Diurnal Wobble of the Earth's Axis of Rotation in Latitude and Time Observations. Application to the Paris Astrolabe Observations from 1956.6 to 1973.8", Geophys. J. R. astr. Soc., 43, 573.
- Caputo, M., 1962, "Tables for the Deformation of an Earth Model by Surface Mass Distributions", J. Geophys. Res., 67, 1611.
- Caputo, M., 1967, The Gravity Field of the Earth, Academic Press, New York.

- Cartwright, D., W. Munk and B. Zetler, 1969, "Pelagic Tidal Measurements", EOS, Trans. AGU, 50, 472.
- Challinor, R.A., 1971, "Variations in the Rate of Rotation of the Earth", Science, 172, 1022.
- Chandler, S.C., 1891, "On the Variation of Latitude", Astron. J., 11, 83.
- Chase, C.G., 1972, "The N Plate Problem of Plate Tectonics", Geophys. J. R. astr. Soc., 29, 117.
- Chinnery, M.A. and F.H. Wells, 1972, "On the Correlation between Earthquake Occurrence and Disturbances in the Path of the Rotation Pole", p. 215, Melchior, P. and S. Yumi (Eds.), Rotation of the Earth, Reidel Pub. Co., Dordrecht-Holland.
- Chovitz, B.H., 1975, "Geodetic Theory", Revs. Geophys. Space Phys., 13, 243.
- Clague, D.A. and R.J. Jarrard, 1973, "Tertiary Pacific Plate Motion Deduced from the Hawaiian-Emperor Chain", Geol. Soc. Amer. Bull., 84, 1135.
- Coleman, P.J., Jr., 1971, "Solar Wind Torque on the Geomagnetic Cavity", J. Geophys. Res., 76, 3800.
- Colombo, G. and I.I. Shapiro, 1968, "Theoretical Model for the Chandler Wobble", Nature, 217, 156.
- Comfort, G.C., 1973, "Direct Mapping of Gravity Anomalies by Using Doppler Tracking between a Satellite Pair", J. Geophys. Res., 78, 6845.
- Cook, A.H., 1963, "The Contribution of Observations of Satellites to the Determination of the Earth's Gravitational Potential", Space Sci. Rev., 2, 355.
- Cowling, T.G., 1957, Magnetohydrodynamics, John Wiley and Sons, New York.
- Darwin, G.H., 1879, "On the Bodily Tides of Viscous and Semi-Elastic Spheroids and on the Ocean Tides upon a Yielding Nucleus", Sci. Papers, 2, 1.
- Defant, A., 1961, Physical Oceanography, The MacMillan Co., New York.
- Dewey, J.F., 1972, "Plate Tectonics", Scientific American, 226, 56.



- Doodson, A.T., 1921, "The Harmonic Development of the Tide-Generating Potential", Proc. Roy. Soc. A, 100, 305.
- Doodson, A.T., 1927, "Application of Numerical Methods of Integration to Tidal Dynamics", Mon. Not. Roy. Astr. Soc., Geophys. Suppl., 1, 541.
- Doodson, A.T., 1936, "IX Tides in Oceans Bounded by Meridians; II - Ocean Bounded by Complete Meridians: Diurnal Tides", Trans. Roy. Soc. A, 235, 290.
- Doodson, A.T., 1957, "The Analysis and Prediction of Tides in Shallow Water", Int. Hydrogr. Rev. (Monaco).
- Dronkers, J.J., 1964, Tidal Computations, John Wiley and Sons, Inc., New York.
- Egedal, J., 1959, "On a Pseudo-Iterating Method for Reduction of Observations of Earth-Tide for Effects from Tides of the Seas, with an Application to Observations Made at Bergen (Norway) 1934", J. Atmosph. Terrestr. Phys., 16, 318.
- Eliassen, E., 1958, "A Study of the Long Atmospheric Waves on the Basis of Zonal Harmonic Analysis", Tellus, 10, 206.
- Eliassen, E. and B. Machenhauer, 1965, "A Study of the Fluctuations of the Atmospheric Planetary Flow Patterns Represented by Spherical Harmonics", Tellus, 17, 220.
- Ellsaesser, H.W., 1966, "Expansion of Hemispheric Meteorological Data in Antisymmetric Surface Spherical Harmonics (Laplace) Series", J. Appl. Meteorol., 5, 263.
- Elsasser, W.M., 1950, "The Earth's Interior and Geomagnetism", Revs. Mod. Phys., 22, 1.
- Euler, L., 1765, Theoria Motus Corporum Solidorum seu Rigidorum, Greifswald.
- Fairbairn, L.A., 1955, "The Semi-Diurnal Tide along the Equator in the Indian Ocean", Phil. Trans. Roy. Soc. London A, 247, 191.
- Fast Fourier Transform, Special Issue on, 1967, IEEE Trans. on Audio and Electroacoustics, AU-15, 44.
- Feissel, M., B. Guinot and N. Tatum, 1972, "Comparison of the Coordinates of the Pole as Obtained by Classical Astrometry (IPMS, BIH) as are Obtained by Doppler Measurements on Artificial Satellites (DPMS)", p. 104, Melchior, P. and S. Yumi (Eds.), Rotation of the Earth, Reidel Pub. Co., Dordrecht-Holland.

- Fliegel, H.F. and T.P. Hawkins, 1967, "Analysis of Variations in the Rotation of the Earth", *Astron. J.*, 72, 544.
- Forward, R.L., 1973, "A Review of Artificial Satellite Gravity Gradiometer Techniques for Geodesy", presented at First International Symposium on the use of Artificial Satellites for Geodesy and Geodynamics, Athens, Greece.
- Frostman, T.O., D.W. Martin and S. Schwerdtfeger, 1967, "Annual and Semi-Annual Variations in the Length of Day, Related to Geophysical Effects", *J. Geophys. Res.*, 72, 5065.
- Gaposchkin, E.M., 1972, "Analysis of Pole Position from 1846 to 1970", p. 19, Melchior, P. and S. Yumi (Eds.), Rotation of the Earth, Reidel Pub. Co., Dordrecht-Holland.
- Gaposchkin, E.M., 1974, "Earth's Gravity Field to the Eighteenth Degree and Geocentric Coordinates for 104 Stations from Satellite and Terrestrial Data", *J. Geophys. Res.*, 79, 5377.
- Gaposchkin, E.M., 1975, "Dynamic Satellite Geodesy", *Revs. Geophys. Space Phys.*, 13, 265.
- Garrett, C., 1972, "Tidal Resonance in the Bay of Fundy and Gulf of Maine", *Nature*, 238, 441.
- Glaser, R.J. and E.J. Sherry, 1972, "Comparison of Satellite Gravitational Techniques", Presented at the International Symposium on Earth Gravity Models and Related Problems, St. Louis, Mo.
- Gold, T., 1967, "Radio Method for the Precise Measurement of the Rotation Period of the Earth", *Science*, 157, 302.
- Goldsbrough, G.R., 1927, "The Tides in Oceans on a Rotating Globe - Part I", *Proc. Roy. Soc. London A*, 117, 692.
- Goldsbrough, G.R., 1929, "The Tides in Oceans on a Rotating Globe - Part III", *Proc. Roy. Soc. London A*, 126, 1.
- Graber, M.A., 1974, "Resonance Effects in Polar Motion Measurable by Radio Interferometry and Laser Ranging", *J. Geophys. Res.*, 79, 1709.
- Graber, M.A., 1976, "Polar Motion Spectra Based upon Doppler, IPMS and BIH Data", *Geophys. J. R. astr. Soc.*, 46, 75.
- Graham, R.D., 1955, "An Empirical Study of Planetary Waves by Means of Harmonic Analysis", *J. Meteorol.*, 12, 298.

- Gribbin, J. and S. Plageman, 1973, "Discontinuous Change in Earth's Spin Rate following Great Solar Storm of August 1972", Nature, 243, 26.
- Guinot, B., 1965, "La Variation de la Latitude a Paris. Resultats et Analyse des Observations", Bull. Astron., 24, 461.
- Guinot, B., 1970, "Work of the Bureau Internationale de l'Heure on the Rotation of the Earth", p. 55, Mansinha et al. (Eds.), Earthquake Displacement Fields and the Rotation of the Earth, Springer-Verlag, New York.
- Guinot, B., 1972, "Comments on the Change in Amplitude of the Chandlerian Wobble", p. 56, Melchior, P. and S. Yumi (Eds.), Rotation of the Earth, Reidel Pub. Co., Dordrecht-Holland.
- Hapgood, C.H., 1970, The Path of the Pole, Chilton Book Co., New York.
- Harrison, J.C., N.F. Ness, I.M. Longman, R.F.S. Forbes, E.A. Kraut and L.B. Slichter, 1963, "Earth-Tide Observations Made during the International Geophysical Year", J. Geophys. Res., 68, 1497.
- Hassan, E.S.M., 1960, "Fluctuations in the Atmospheric Inertia 1873-1950", Meteorological Monographs, 4, 609.
- Haubrich, R.A., 1970, "An Examination of the Data Relating Pole Motion to Earthquakes", p. 149, Mansinha et al. (Eds.), Earthquake Displacement Fields and the Rotation of the Earth, Springer-Verlag, New York.
- Haurwitz, B., 1940, "The Motion of Atmospheric Disturbances on the Spherical Earth", J. Marine Research, 3, 254.
- Heiskanen, W.A. and H. Moritz, 1967, Physical Geodesy, W. H. Freeman and Co., San Francisco.
- Heiskanen, W.A. and F.A. Vening Meinesz, 1958, The Earth and its Gravity Field, McGraw-Hill Book Co., Inc., New York.
- Hendershott, M.C., 1972, "The Effects of Solid Earth Deformation on Global Ocean Tide", Geophys. J. R. astr. Soc., 29, 389.
- Hendershott, M.C., 1975, "Numerical Models of Ocean Tides", Preliminary paper, Scripps Inst. of Oceanography, U. Cal. at San Diego, to appear as Vol. VI in The Sea.

- Hildebrand, F.B., 1956, Introduction to Numerical Analysis, McGraw-Hill Book Co. Inc., New York.
- Hines, C.O., 1974, "Solar Wind Torque as an Inhibitor of Terrestrial Rotation", *J. Geophys. Res.*, 79, 1543.
- Hirshberg, J., 1972, "Upper Limits of the Torque of the Solar Wind on the Earth", *J. Geophys. Res.*, 77, 4855.
- Hopkins, J., 1972, "Analysis of Methods for Computing an Earth Gravitational Model from a Combination of Terrestrial and Satellite Data", p. 93, Henriksen, S.W., A. Mancini and B.H. Chovitz (Eds.), The Use of Artificial Satellites for Geodesy, Geophysical Monograph No. 15, AGU, Washington, D.C.
- Hotine, M., 1969, Mathematical Geodesy, U.S. Dept. of Commerce, ESSA, Washington, D.C.
- Hurwitz, L., D.G. Knapp, J.H. Nelson and D.E. Watson, 1966, "Mathematical Model of the Geomagnetic Field for 1965", *J. Geophys. Res.*, 71, 2373.
- Iijima, S., N. Matsunami and S. Okazaki, 1964, "On the Abrupt Change in the Earth's Rotation in the Beginning of 1963", *Annals, Tokyo Astronomic Observatory*, 8, 205.
- Iijima, S. and S. Okazaki, 1972, "Short Period Terms in the Rate of Rotation and in the Polar Motion of the Earth", *Pub. Astron. Soc. Japan*, 24, 109.
- Inglis, D.R., 1965, "The Dynamo Model, Field Reversal, and Polar Wandering", *J. Geomag. Geoelectr.*, 17, 517.
- Irish, J.W., W. Munk and F. Snodgrass, 1971, "M<sub>2</sub> Amphidromes in the Northeast Pacific", *Geophys. Fluid Dynamics*, 2, 355.
- Israel, M., A. Ben-Menahem and S.J. Singh, 1973, "Residual Deformation of Real Earth Models with Application to the Chandler Wobble", *Geophys. J. R. astr. Soc.*, 32, 219.
- James, R.W., 1968, "An Equation for Estimating Westward Drift", *J. Geomag. Geoelectr.*, 20, 429.
- Jeffreys, H., 1916, "Causes Contributory to the Annual Variation of Latitude", *Mon. Not. Roy. Astr. Soc.*, 76, 499.
- Jeffreys, H., 1940, "The Variation of Latitude", *Mon. Not. Roy. Astr. Soc.*, 100, 139.

- Jeffreys, H., 1968, "The Variation of Latitude", Mon. Not. Roy. Astr. Soc., 141, 255.
- Jeffreys, H., 1970, The Earth, 5th Ed., Cambridge Univ. Press, London.
- Jeffreys, H., 1972, "The Variation of Latitude" p. 39, Melchior, P. and S. Yumi (Eds.), Rotation of the Earth, Reidel Pub. Co., Dordrecht-Holland.
- Jeffreys, H. and B.S. Jeffreys, 1962, Methods of Mathematical Physics, Cambridge Univ. Press, London.
- Jeffreys, H. and R.O. Vicente, 1957a, "The Theory of Nutation and the Variation of Latitude", Mon. Not. Roy. Astr. Soc., 117, 142.
- Jeffreys, H. and R.O. Vicente, 1957b, "The Theory of Nutation and the Variation of Latitude: The Roche Model Core", Mon. Not. Roy. Astr. Soc., 117, 162.
- Jones, H.S., 1961, "Variations of the Earth's Rotation", Chap. 4, Ahrens, L.H. et al. (Eds.), Physics and Chemistry of the Earth, vol. 4, Pergamon Press, Inc., New York.
- Kahle, A.B., E.H. Vestine and R.H. Ball, 1967, "Estimated Surface Motions of the Earth's Core", J. Geophys. Res., 72, 1095.
- Kaula, W.M., 1966, Theory of Satellite Geodesy, Blaisdell Pub. Co., Waltham, Mass.
- Kaula, W.M., 1967, "Theory of Statistical Analysis of Data Distributed over a Sphere", Revs. Geophys., 5, 83.
- Kaula, W.M., 1968, An Introduction to Planetary Physics, John Wiley and Sons, Inc., New York.
- Kaula, W.M., 1969, "Tidal Friction with Latitude-Dependent Amplitude and Phase Angle", Astron. J., 74, 1108.
- Kaula, W.M., 1970, "The Terrestrial Environment: Solid-Earth and Ocean Physics", NASA CR-1579.
- Kaula, W.M., 1975, "Absolute Plate Motions by Boundary Velocity Minimizations", J. Geophys. Res., 80, 244.
- Koch, K.R., 1974, "Earth's Gravity Field and Station Coordinates from Doppler Data, Satellite Triangulation, and Gravity Anomalies", Tech. Rpt. NOS-62, NOAA, Washington, D.C.

- Kozai, Y., 1965, "Effects of the Tidal Deformation of the Earth on the Motion of Close Earth Satellites", *Astron. Soc. of Japan*, 17, 395.
- Kuo, J.T. and M. Ewing, 1966, "Spatial Variations of Tidal Gravity", p. 595, Steinhart, J.S. and T.J. Smith (Eds.), The Earth Beneath the Continents, W. Byrd Press, Richmond, Va.
- Kuo, J.T. and R.C. Jachens, 1970, "Transcontinental Tidal Gravity Profile across the United States", *Science*, 168, 968.
- Lamb, H., 1917, "On the Deflection of the Vertical by Tidal Loading of the Earth Surface", *Proc. Roy. Soc. London A*, 93, 293.
- Lambeck, K., 1972, "Polar Motion from the Tracking of Close Earth Satellites", p. 123, Melchior, P. and S. Yumi (Eds.), Rotation of the Earth, Reidel Pub. Co., Dordrecht-Holland.
- Lambeck, K., 1975, "Effects of Tidal Dissipation in the Oceans on the Moon's Orbit and the Earth's Rotation", *J. Geophys. Res.*, 80, 2917.
- Lambeck, K. and A. Cazenave, 1973, "The Earth's Rotation and Atmospheric Circulation - I. Seasonal Variations", *Geophys. J. R. astr. Soc.*, 32, 79.
- Lambeck, K. and A. Cazenave, 1974, "The Earth's Rotation and Atmospheric Circulation - II. The Continuum", *Geophys. J. R. astr. Soc.*, 38, 49.
- Lambeck, K., A. Cazenave and G. Balmino, 1974, "Solid Earth and Ocean Tides Estimated from Satellite Orbit Analysis", *Revs. Geophys. Space Phys.*, 12, 421.
- Lambert, A., 1970, "The Response of the Earth to Loading by the Ocean Tides around Nova Scotia", *Geophys. J. R. astr. Soc.*, 19, 449.
- Lambert, A., 1974, "Earth Tide Analysis and Prediction by the Response Method", *J. Geophys. Res.*, 79, 4952.
- Lambert, W.D., 1942, "Notes on Earth Tides", *Geophys.*, 7, 51.
- Laplace, P.S., 1796-1825, Traité de Mécanique Céleste, Tome I-IV, Paris.
- Leaton, B.R., S.R.C. Malin and M.J. Evans, 1965, "An Analytical Representation of the Estimated Geomagnetic Field and its Secular Change for the Epoch 1965.0", *J. Geomag. Geoelectr.*, 17, 187.

- Lennon, G.W., 1962, "The Deviation of the Vertical at Bidston in Response to the Attraction of Ocean Tides", *Geophys. J. R. astr. Soc.*, 6, 64.
- LePichon, X., 1968, "Sea Floor Spreading and Continental Drift", *J. Geophys. Res.*, 73, 3661.
- Lerch, F.J., J.A. Richardson and J.E. Brown, 1974, "Goddard Earth Models GEM 5 and 6", Doc. X-921-74-145, Goddard Space Flight Center, Greenbelt, Md.
- Lisitzin, E., 1974, Sea-Level Changes, Elsevier Scientific Pub. Co., New York.
- Liu, H., L. Carpenter and R.W. Agreen, 1974, "Plate Motion and the Secular Shift of the Mean Pole", *J. Geophys. Res.*, 79, 4379.
- Longman, I.M., 1962, "A Green's Function for Determining the Deformation of the Earth under Surface Mass Loads", *J. Geophys. Res.*, 67, 845.
- Longman, I.M., 1963, "A Green's Function for Determining the Deformation of the Earth under Surface Mass Loads: 2. Computations and Numerical Results", *J. Geophys. Res.*, 68, 485.
- Longman, I.M., 1966, "Computation of Love Numbers and Load Deformation Coefficients for a Model Earth", *Geophys. J. R. astr. Soc.*, 11, 133.
- Love, A.E., 1909, "The Yielding of the Earth to Disturbing Forces", *Proc. Roy. Soc. London A*, 82, 73.
- Love, A.E., 1911, Some Problems of Geodynamics, Cambridge Univ. Press, Dover Pub., New York.
- Lundquist, C.A., 1974, "Nature of the Requirements for Reference Coordinate Systems", Keynote presentation at the International Colloquium on Reference Coordinate Systems for Earth Dynamics, Torun, Poland.
- Lundquist, C.A. and G.E.O. Giacaglia, 1972, "Use of Altimeter Data in a Sampling Function Approach to the Geoid", p. 4, Sea Surface Topography from Space, Tech. Rpt. ERL228-AOML7, NOAA, Washington, D.C.
- Luther, D.S. and C. Wunsch, 1975, "Tidal Charts of the Central Pacific Ocean", *J. Phys. Oceanography*, 5, 222.

- Malfait, B.T. and R.G. Dinkleman, 1972, "Circum-Caribbean Tectonic and Igneous Activity and the Evolution of the Caribbean Plate", *Geol. Soc. Amer. Bull.*, 83, 251.
- Malin, S.R.C. and I. Saunders, 1973, "Rotation of the Earth's Magnetic Field", *Nature*, 245, 25.
- Mansinha, L. and D.E. Smylie, 1967, "Effect of Earthquakes on the Chandler Wobble and the Secular Polar Shift", *J. Geophys. Res.*, 72, 4731.
- Mansinha, L. and D.E. Smylie, 1970, "Seismic Excitation of the Chandler Wobble", p. 122, Mansinha, L., D.E. Smylie and A.E. Beck (Eds.), Earthquake Displacement Fields and the Rotation of the Earth, Springer-Verlag, New York.
- Mansinha, L., D.E. Smylie and A.E. Beck (Eds.), Earthquake Displacement Fields and the Rotation of the Earth, Springer-Verlag, New York.
- Markowitz, W., 1942, "The Free Polar Motion", *Astron. J.*, 50, 17.
- Markowitz, W., 1970, "Sudden Changes in Rotational Acceleration of the Earth and Secular Motion of the Pole", p. 69, Mansinha, L. D.E. Smylie and A.E. Beck (Eds.), Earthquake Displacement Fields and the Rotation of the Earth, Springer-Verlag, New York.
- Maximov, I.V., 1970, The Geophysical Forces and Water in the Oceans, Gidrometesrologicheskoe Izdatelstvo, Leningrad (in Russian).
- McCandless, S.R., Jr., 1974, "SEASAT-A - A User Oriented Systems Design", p. 67, Proc. Int. Symposium on Applications of Marine Geodesy, Marine Technology Society, Washington, D.C.
- McCandless, S.W. and B.P. Miller, 1975, "Scientific and Economic Potential of the SEASAT Program", *Acta Astronautica*, 2, 771.
- McCarthy, D.D., 1974, "The Variation of Latitude Based on U.S. Naval Observatory Photographic Zenith Tube Observations", *J. Geophys. Res.*, 79, 3343.
- McClure, P., 1976, "Core-Resonance Effects on the Earth's Angular Momentum Vector and Rotation Axis - A Generalized Model", Presented at Spring Meeting of the AGU, Washington, D.C.



- McGoogan, J.T., D.C. Leitao, L.S. Miller and W.T. Wells, 1974, "Skylab S-193 Altimeter Experiment Performance, Results and Applications", p. 291, Proc. Int. Symposium on Applications of Marine Geodesy, Marine Technology Society, Washington, D.C.
- McKenzie, D.P., J.M. Roberts and N.O. Weiss, 1974, "Convection in the Earth's Mantle: Toward a Numerical Simulation", J. Fluid Mech., 62, 465.
- Melchior, P., 1966, The Earth Tides, Pergamon Press, New York.
- Melchior, P. and S. Yumi (Eds.), 1972, Rotation of the Earth, Reidel Pub. Co., Dordrecht-Holland.
- Minster, J.B., T.H. Jordan, P. Molnar and E. Haines, 1974, "Numerical Modeling of Instantaneous Plate Tectonics", Geophys. J. R. astr. Soc., 36, 541.
- Mintz, Y. and W. Munk, 1951, "The Effect of Winds and Tides on the Length of the Day", Tellus, 3, 117.
- Mintz, Y. and W. Munk, 1954, "The Effect of Winds and Bodily Tides on the Annual Variation in the Length of the Day", Mon. Not. Roy. Astr. Soc., Geophys. Suppl., 6, 566.
- Morgan, W.J., 1968, "Rises, Trenches, Great Faults, and Crustal Blocks", J. Geophys. Res., 73, 1959.
- Moses, H.E., 1974, "The Use of Vector Spherical Harmonics in Global Meteorology and Aeronomy", J. Atmosph. Sci., 31, 1490.
- Mourad, A.G., 1975, "Marine Geodesy", Revs. Geophys. Space Phys., 13, 253.
- Mueller, I.I., 1969, Spherical and Practical Astronomy, Ungar Pub. Co., New York.
- Mueller, I.I. and C.R. Schwarz, 1972, "Separating the Secular Motion of the Pole from Continental Drift", p. 68, Melchior, P. and S. Yumi (Eds.), Rotation of the Earth, Reidel Pub. Co., Dordrecht-Holland.
- Munk, W. and D.E. Cartwright, 1966, "Tidal Spectroscopy and Prediction", Phil. Trans. Roy. Soc. A, 259, 533.
- Munk, W. and E. Groves, 1952, "The Effect of Winds and Ocean Currents on the Annual Variation in Latitude", J. Meteorol., 9, 385.
- Munk, W. and E. Hassan, 1961, "Atmospheric Excitation of the Earth's Wobble", Geophys. J. R. astr. Soc., 4, 339.

- Munk, W. and G.J.F. MacDonald, 1960, The Rotation of the Earth, Cambridge Univ. Press, London.
- Munk, W. and R.L. Miller, 1950, "Variations in the Earth's Angular Velocity Resulting from Fluctuations in Atmospheric and Oceanic Circulation", Tellus, 2, 93.
- Munk, W. and R. Revelle, 1952, "On the Geophysical Interpretation of Irregularities in the Rotation of the Earth", Mon. Not. Roy. Astr. Soc., Geophys. Suppl., 6, 331.
- Munk, W., F. Snodgrass and M. Wimbush, 1970, "Tides Off-Shore: Transition from California Coastal to Deep-Sea Waters", Geophys. Fluid Dynamics, 1, 161.
- Musen, P. and R. Estes, 1972, "On the Tidal Effects in the Motion of Artificial Satellites", Celestial Mech., 6, 4.
- Musen, P. and T. Felsentreger, 1973, "On the Determination of the Long Period Tidal Perturbations in the Elements of Artificial Earth Satellites", Celestial Mech., 7, 256.
- Nagata, T., 1962, "Two Main Aspects of Geomagnetic Secular Variation - Westward Drift and non-Drifting Components", p. 39, Proc. Benedum Earth Magnetism Symposium, Pittsburgh Univ. Press.
- Nagata, T., 1965, "Main Characteristics of Recent Geomagnetic Secular Variation", J. Geomag. Geoelectr., 17, 263.
- Neatan, S.M., 1946, "The Motion of Harmonic Waves in the Atmosphere", J. Meteorol., 3, 53.
- Neumann, G. and W.J. Pearson, Jr., 1966, Principles of Physical Oceanography, Prentice Hall, Inc., Englewood Cliffs, N.J.
- Newcomb, S., 1892, "Remarks on Mr. Chandler's Law of Variation of Terrestrial Latitudes", Astron. J., 12, 49.
- Nishimura, E., 1950, "On Earth Tides", Trans. AGU, 31, 357.
- O'Connell, R.J. and A.M. Dziewonski, 1976, "Excitation of the Chandler Wobble by Large Earthquakes", (To be published in Nature.)
- O'Hara, N.P.J. and C.J.A. Penny, 1973, "Rotation of the Earth during the 1972 Solar Event", Nature, 244, 426.
- O'Hara, N.P.J. and D.V. Thomas, 1970, "An Investigation of PZT Observations for Evidence of the Existence of Polar Disturbances Due to Large Earthquakes", p. 169, Mansinha, L., D.E. Smylie and A.E. Beck (Eds.), Earthquake Displacement Fields and the Rotation of the Earth, Springer-Verlag, New York.

- Okazaki, S. and M. Nasaka, 1972, "Comparisons between Results of Polar Coordinates Derived from Time Data and those from Latitude Ones", p. 56, Melchior, P. and S. Yumi (Eds.), Rotation of the Earth, Reidel Pub. Co., Dordrecht-Holland.
- Parke, M., 1976, (Personal Communication.)
- Parker, E.N., 1955, "Hydrodynamic Dynamo Models", *Astrophys. J.*, 122, 293.
- Pedersen, G.P.H. and M.G. Rochester, 1972, "Spectral Analysis of the Chandler Wobble", p. 33, Melchior, P. and S. Yumi (Eds.), Rotation of the Earth, Dordrecht-Holland.
- Pekeris, C.L. and Y. Accad, 1969, "Solution of Laplace's Equations for the  $M_2$  Tide in the World Oceans", *Phil. Trans. Roy. Soc. London A*, 265, 413.
- Pellinen, L.P., 1965, "Determination of the Coefficients of Expression of the Earth's Gravitational Potential into Spherical Functions from Joint Processing of Gravimetric and Satellite Data", *Geodesy and Aerotopography* (Translated for AGU), 3.
- Pines, D. and J. Shaham, 1973, "Seismic Activity, Polar Tides and the Chandler Wobble", *Nature*, 245, 77.
- Platzman, G.W., 1960, "The Spectral Form of the Vorticity Equation", *J. Meteorol.*, 17, 635.
- Platzman, G.W., 1975, "Normal Modes of the Atlantic and Indian Oceans", *J. Physical Oceanography*, 5, 201.
- Proudman, J., 1916, "On the Dynamical Equations of the Tides; Part I - Tidal Systems with Finite Freedom", *Proc. Lond. Math. Soc.*, 18, 1.
- Proudman, J., 1925, "A Theorem in Tidal Dynamics", *Phil. Mag.*, 49, 570.
- Proudman, J., 1932, "On the Dynamical Equations of the Tides; Part IV - Flat Seas of Uniform Depth", *Proc. Lond. Math. Soc.*, 34, 293.
- Proudman, J., 1936, "IX - Tides in Oceans Bounded by Meridians; I - Ocean Bounded by Complete Meridian: General Equations", *Trans. Roy. Soc. A*, 235, 273.
- Proudman, J., 1944, "The Tides of the Atlantic Ocean", *Mon. Not. Roy. Astr. Soc.*, 104, 244.

- Proverbio, E., F. Carta and F. Mazzoleni, 1972, "Secular and Long-Term Variations of the Polar Motion", p. 97, Melchior, P. and S. Yumi (Eds.), Rotation of the Earth, Reidel Pub. Co., Dordrecht-Holland.
- Proverbio, E. and V. Quesada, 1974, "Secular Variations in Latitudes and Longitudes and Continental Drift", J. Geophys. Res., 79, 4941.
- Rapp, R.H., 1971, "A Procedure for Combining Satellite and Gravimetric Data for Position and Gravity Field Determinations", J. Geophys. Res., 76, 4986.
- Rikitake, T., 1966, Electromagnetism and the Earth's Interior, Elsevier, New York.
- Rochester, M.G., 1960, "Geomagnetic Westward Drift and Irregularities in the Earth's Rotation", Phil. Trans. Roy. Soc. A, 252, 531.
- Rochester, M.G., 1968, "Perturbations in the Earth's Rotation and Geomagnetic Core-Mantle Coupling", J. Geomag. Geoelectr., 20, 387.
- Rochester, M.G., 1970, "Core-Mantle Interactions: Geophysical and Astronomical Consequences", p. 136, Mansinha, L., D.E. Smylie and A.E. Beck (Eds.), Earthquake Displacement Fields and the Rotation of the Earth, Springer-Verlag, New York.
- Rochester, M.G., 1973, "The Earth's Rotation", EOS, Trans. AGU, 54, 769.
- Rochester, M.G., O.G. Jensen and D.E. Smylie, 1974, "A Search for the Earth's 'Nearly Diurnal Free Wobble'", Geophys. J. R. astr. Soc., 38, 349.
- Rochester, M.G. and D.E. Smylie, 1965, "Geomagnetic Core-Mantle Coupling and the Chandler Wobble", Geophys. J. R. astr. Soc., 10, 289.
- Rosenhead, L., 1929, "The Annual Variation of Latitude", Mon. Not. Roy. Astr. Soc., 2, 140.
- Rudnick, P., 1956, "The Spectrum of the Variation in Latitude", Trans. AGU, 37, 137.
- Runcorn, S., 1954, "The Earth's Core", Trans. AGU, 35, 49.
- Runcorn, S., 1970, "A Possible Cause of the Correlation between Earthquakes and Polar Motions", p. 181, Mansinha, L., D.E. Smylie and A.E. Beck (Eds.), Earthquake Displacement Fields and the Rotation of the Earth, Springer-Verlag, New York.

- Schmidt, A., 1964, "Tables of Normalized Spherical Functions and Their Derivatives", NASA TT-F-8888.
- Shida, T. and M. Matsuyana, 1912, "Note on Hecker's observations of Horizontal Pendulums", Memoirs of the College of Science and Engineering, Kyota Imperial Univ., 4, 187.
- Shimazaki, K. and H. Takeuchi, 1972, "Excitation of the Chandler Wobble by Large Earthquakes", p. 224, Melchior, Pl and S. Yumi (Eds.), Rotation of the Earth, Reidel Pub. Co., Dordrecht-Holland.
- Shureman, P., 1941, Manual of Harmonic Analysis and Prediction of Tides, U.S. Coast and Geodetic Survey, Washington, D.C.
- Sidorenkov, N.S., 1968, "The Influence of Atmospheric Circulations on the Earth's Rotational Velocity, 1956.8-1964.8", Soviet Astronomy-AJ, 12, 706.
- Sidorenkov, N.S., 1973, "The Inertia Tensor of the Atmosphere, the Annual Variation of its Components, and the Variations of the Earth's Rotation", Acad. Sci., USSR, Izvestiga, Atmospheric and Ocean Physics, 9, 185.
- Silberman, I., 1963, "Planetary Waves in the Atmosphere", J. Meteorol., 11, 27.
- Siran, G., 1969, "Ponderomotoric Forces and Sudden Irregularities in the Earth's Rotation, II", Studia Geophysica et Geodaetica, 13, 180.
- Sleep, N.H., 1975, "Stress and Flow Beneath Island Arcs", Geophys. J. R. astr. Soc., 42, 827.
- Slichter, L.B., 1970, "Earth Tides", p. 285, Robertson, E.C., J.F. Hays and L. Knopoff (Eds.), The Nature of the Solid Earth, Papers presented at a symposium held at Harvard Univ., Cambridge, Mass.
- Smylie, D.E., G.K.C. Clarke and L. Mansinha, 1970, "Deconvolution of the Pole Path", p. 99, Mansinha, L., D.E. Smylie and A.E. Beck (Eds.), Earthquake Displacement Fields and the Rotation of the Earth, Springer-Verlag, New York.
- Smylie, D.E. and L. Mansinha, 1968, "Earthquakes and the Observed Motion of the Rotation Pole", J. Geophys. Res., 73, 7661.
- Solomon, S.C. and N.H. Sleep, 1974, "Some Simple Physical Models for Absolute Plate Motions", J. Geophys. Res., 79, 2557.

- Solomon, S.C., N.H. Sleep and R.M. Richardson, 1975, "On the Forces Driving Plate Tectonics: Inferences from Absolute Plate Velocities and Intraplate Stress", *Geophys. J. R. astr. Soc.*, 42, 769.
- Sperry UNIVAC 1100 Series, 1970a, "Math Pack", UP-7542 Rev. 1.
- Sperry UNIVAC 1100 Series, 1970b, "Stat Pack", UP-7502 Rev. 1.
- Sperry UNIVAC 1100 Series, 1974, "FORTRAN V Library Programmer Reference", UP-7876.
- Sperry UNIVAC 1100 Series, 1975, "Mathematical Function Library", UP-8007 Rev. 2.
- Sperry UNIVAC 1100 Series, 1976, "FORTRAN V Programmer Reference", UP-4060 Rev. 2.
- Stanley, H.R., N.A. Roy and C.F. Martin, 1972, "Rapid Global Mapping with Satellite Altimetry", p. 209, The Use of Artificial Satellites for Geodesy, AGU Monograph 15, Washington, D.C.
- Steenbeck, M. and G. Helmis, 1975, "Rotation of the Earth's Solid Core as a Possible Cause of Declination, Drift and Reversals of the Earth's Magnetic Field", *Geophys. J. R. astr. Soc.*, 41, 237.
- Stokes, G.C., 1849, "On the Variation of Gravity on the Surface of the Earth", *Trans. Cambridge Phil. Soc.*, 8, 672.
- Supplement to the American Ephemeris, 1968, Naval Observatory, Washington, D.C.
- Takeuchi, H., 1950, "On the Earth Tide of the Compressible Earth of Variable Density and Elasticity", *Trans. AGU*, 31, 651.
- Takeuchi, H., 1966, Theory of the Earth's Interior, Blaisdell Pub. Co., Waltham, Mass.
- Takeuchi, H., S. Uyeda and K. Kanamori, 1967, Debate about the Earth, Freeman, Cooper and Co., San Francisco.
- Tanni, L., 1948, "On the Continental Ondulations of the Geoid as Determined from Present Gravity Material", *Pub. Isostat. Inst. Assoc. Geodesy*, No. 18.
- Thomson, W., 1875, "Note on the Oscillation of the First Species in Laplace's Theory of the Tides", *Phil. Mag.*, 50, 1.

- Toomre, A., 1974, "On the 'Nearly Diurnal Wobble' of the Earth", *Geophys. J. R. astr. Soc.*, 38, 335.
- Triet, L.M., 1974, "A Note on the Phase Lag Between the Westward Drift of the Geomagnetic Field and the Secular Change in the Earth's Rotation", *Acta Geophysica Polonica*, 22, 21.
- Turcotte, D.L., 1975, "The Driving Mechanism of Plate Tectonics", *Revs. Geophys. and Space Phys.*, 13, 333.
- Uotilla, U.A., 1960, "Investigations on the Gravity Field and Shape of the Earth", Helsinki, Pub. Isostat. Inst. Int. Assoc. Geodesy, No. 33.
- Vaniček, P., 1969, "New Analysis of the Earth-Pole Wobble", *Studia Geophysica et Geodactia*, 13, 225.
- Vestine, E.H., 1952, "On Variations of the Geomagnetic Field, Fluid Motions, and the Rate of the Earth's Rotation", *Nat. Acad. Sci.*, 38, 1030.
- Vestine, E.H., 1953, "On Variations of the Geomagnetic Field, Fluid Motions, and the Rate of the Earth's Rotation", *J. Geophys. Res.*, 58, 127.
- Vestine, E.H. and A.B. Kahle, 1968, "The Westward Drift and Geomagnetic Secular Change", *Geophys. J. R. astr. Soc.*, 15, 29.
- Vestine, E.H., W.L. Sibley, J.W. Kern and J.L. Carlstedt, 1963a, "Integral and Spherical-Harmonic Analyses of the Geomagnetic Field for 1955.0, Part 1", *J. Geomag. Geoelectr.*, 15, 47.
- Vestine, E.H., W.L. Sibley, J.W. Kern and J.L. Carlstedt, 1963b, "Integral and Spherical-Harmonic Analyses of the Geomagnetic Field for 1955.0, Part 2", *J. Geomag. Geoelectr.*, 15, 73.
- Vicente, R.O., 1961, "The Theory of Nutation and the Internal Constitution of the Earth", Chap. 7, Ahrens, L.H. et al. (Eds.), Physics and Chemistry of the Earth, vol. 4, Pergamon Press, Inc., New York.
- Vicente, R.O. and S. Yumi, 1969, "Coordinates of the Pole (1849-1968) Referred to the Conventional International Origin", Pub. Int. Latitude Observatory of Mizusawa, Japan, 7, 41.

- Vicente, R.O. and S. Yumi, 1970, "Revised Values (1941-1962) of the Coordinates of the Pole Referred to the CIO", Pub. Int. Latitude Observatory of Mizusawa, Japan, 7, 109.
- Wako, Y., 1972, "Kimura's Z-Term and the Liquid Core Theory", p. 189, Melchior, P. and S. Yumi (Eds.), Rotation of the Earth, Reidel Pub. Co., Dordrecht-Holland.
- Walker, A.M. and A. Young, 1955, "The Analysis of the Observations of the Variations of Latitude", Mon. Not. Roy. Astr. Soc., 115, 443.
- Walker, A.M. and A. Young, 1957, "Further Results of the Analysis of the Variations of Latitude", Mon. Not. Roy. Astr. Soc., 117, 119.
- Weiffenbach, G.D., 1972, "An Observational Philosophy for GEOS-C Satellite Altimetry", p. I-1, Proc. of the Conference on Sea Surface Topography from Space, NOAA ERL 228-AOML7, Boulder, Co.
- Wilson, C.R., 1975, "Meteorological Excitation of the Earth's Wobble", Doctoral dissertation, Univ. Cal. at San Diego.
- Wilson, J.T., 1965, "Evidence from Ocean Islands Suggesting Movement in the Earth", Phil. Trans. Roy. Soc. London A, 258, 145.
- Winch, E.E., 1968, "Multipole Analysis and Secular Variation", J. Geomag. Geoelectr., 20, 205.
- Woolard, E.W., 1953, "Theory of the Rotation of the Earth around its Center of Mass", Astron. Papers, U.S. Naval Obs., vol. XV, Part I.
- Woolard, E.W., 1959, "Inequalities in Mean Solar Time from Tidal Variations in the Rotation of the Earth". Astron. J., 64, 140.
- Yashkov, V.Y., 1965, "Spectrum of the Motion of the Earth's Pole", Soviet Astronomy-AJ, 8, 605.
- Yatskiv, Y.S., A.A. Korsun and L.V. Rykhlova, 1973, "Spectrum of the Coordinates of the Earth's Pole during the Period 1846-1971", Soviet Astronomy-AJ, 16, 1041.
- Yionoulis, S. and V. Pisacane, 1972, "Geodetic Applications of Satellite-to-Satellite Tracking, 1, Analysis", TG 1185, Johns Hopkins Univ., Applied Phys. Lab., Baltimore, Md.
- Yukutake, T., 1962, "The Westward Drift of the Magnetic Field of the Earth", Bull. Earthquake Res. Inst., 40, 1.



- Yukatake, T., 1972, "The Effect of Change in the Geomagnetic Dipole Moment on the Rate of the Earth's Rotation", J. Geomag. Geoelectr., 24, 19.
- Yumi, S. and Y. Wako, 1970, "Secular Motion of the Pole", p. 82, Mansinha, L., D.E. Smylie and A.E. Beck (Eds.), Earthquake Displacement Fields and the Rotation of the Earth, Springer-Verlag, New York.
- Zetler, B.D. and R.A. Cummings, 1967, "A Harmonic Method for Predicting Shallow-Water Tides", J. Marine Res., 25, 103.
- Zetler, B., W. Munk, H. Mofjeld, W. Brown and F. Dormer, 1975, "MODE Tides", J. Physical Oceanography, 5, 430.
- Zhongolovich, I.D., 1957, "Gravitational Potential of the Earth", Bull. Inst. Theor. Astron., 6, 505.

