

General Disclaimer

One or more of the Following Statements may affect this Document

- This document has been reproduced from the best copy furnished by the organizational source. It is being released in the interest of making available as much information as possible.
- This document may contain data, which exceeds the sheet parameters. It was furnished in this condition by the organizational source and is the best copy available.
- This document may contain tone-on-tone or color graphs, charts and/or pictures, which have been reproduced in black and white.
- This document is paginated as submitted by the original source.
- Portions of this document are not fully legible due to the historical nature of some of the material. However, it is the best reproduction available from the original submission.

NATIONAL AERONAUTICS AND SPACE ADMINISTRATION

Technical Memorandum 33-752

Volume II

*Tracking and Data Systems Support
for the Helios Project*

*DSN Support of Project Helios
April 1975 Through May 1976*

(NASA-CR-149510) TRACKING AND DATA SYSTEMS
SUPPORT FOR THE HELIOS PROJECT. VOLUME 2:
DSN SUPPORT OF PROJECT HELIOS APRIL 1975 -
MAY 1976 (Jet Propulsion Lab.) 137 p
HC AC7/MF AC1

N77-16103

Unclass
13275

CSC 17E G3/17

JET PROPULSION LABORATORY
CALIFORNIA INSTITUTE OF TECHNOLOGY
PASADENA, CALIFORNIA

January 15, 1977



NATIONAL AERONAUTICS AND SPACE ADMINISTRATION

Technical Memorandum 33-752

Volume II

*Tracking and Data Systems Support
for the Helios Project*

*DSN Support of Project Helios
April 1975 Through May 1976*

P. S. Goodwin

M. R. Traxler

W. G. Meeks

F. M. Flanagan

JET PROPULSION LABORATORY
CALIFORNIA INSTITUTE OF TECHNOLOGY
PASADENA, CALIFORNIA

January 15, 1977

PREFACE

The work described in this report was performed by the engineering and operations personnel of the Tracking and Data Acquisition organizations of the Jet Propulsion Laboratory, Goddard Space Flight Center, Air Force Eastern Test Range, and John F. Kennedy Space Center. This is the second in a series of engineering reports describing the continuing support provided to the Helios Project for the Helios-1 spacecraft from its entrance into first superior conjunction in April 1975 until the completion of third perihelion in April 1976.

This report also describes the TDS support provided the Helios-2 spacecraft during prelaunch planning and development activities begun in May 1975, launch activities in January 1976, and mission support through spacecraft entrance into first superior conjunction in May 1976.

ACKNOWLEDGMENT

The authors express their gratitude to the many JPL contributors whose skills in management, training, planning, and operation described in this report contributed so significantly to the success of the Helios Project, the first joint German/U.S. solar exploration project.

Further, the authors express their thanks for and acknowledge the contributions of Ants Kutzer of the German Society for Space Research and Gilbert W. Ousley of the Goddard Space Flight Center in providing the interface and coordination between our two countries.

Finally, and perhaps most important, the authors wish to recognize the very meaningful contributions of the NASA Headquarters team: the Office of Space Science (OSS) for its program direction to Project Helios and the Office of Tracking and Data Acquisition (OTDA) for continued foresight in providing the network facilities required to support such projects as Helios.

CONTENTS

Part A. Helios-B Prelaunch Planning Through End of Mission Phase I

I.	Introduction	3
A.	Purpose	3
B.	Scope	3
C.	Helios-B Mission Planning	3
II.	Near-Earth Tracking Data System	5
A.	NETDS Management, Interfaces, and Operational Control ..	5
1.	Management	5
2.	Interfaces	5
3.	NETDS Operations Control System	6
B.	Mission Planning	8
1.	NETDS Data Requirements	8
2.	NETDS Trajectory Design	12
3.	NETDS Resource Commitments	13
C.	Implementation and Configurations	18
1.	Launch Vehicle Telemetry	18
2.	Spacecraft Telemetry	20
3.	Metric Data	20
4.	Communications	22
D.	Prelaunch Testing	22
1.	NETDS Testing	22
2.	End-to-End Compatibility Test 5	28
3.	Operational Demonstration Test 1	28
4.	Operational Demonstration Test 2	29
5.	Operational Readiness Test	30

E.	Launch Support	31
1.	Launch Vehicle Telemetry Data	31
2.	Spacecraft Telemetry Support	31
3.	Metric Data Support	37
4.	Communications Support	37
F.	Launch Phase Support Problems and Corrective Action	43
1.	Antigua Island	43
2.	NASA Ship Vanguard	44
3.	ARIA	44
III.	Deep Space Network Support	46
A.	DSN/Helios-B Spacecraft Compatibility Tests	46
1.	Telecommunications Compatibility Tests	46
2.	RF and Data Verification Tests	52
B.	Prelaunch Test and Training	52
1.	Operations Verification Tests	53
C.	Mission Phase I Support	57
1.	Launch Operations	57
2.	DSN Initial Acquisition	57
3.	Step I Maneuver	60
4.	Near-Earth Experiments Turn-On	60
5.	Step II Maneuver	64
Part B. DSN Support of Helios-1 and -2 Mission Phases II and III		
IV.	Helios-2 Mission Phase II	69
A.	First Inferior Conjunction	69
B.	Mu-II Ranging Support for Helios	73
C.	First Perihelion Passage	78
D.	Entrance Into First Solar Superior Conjunction	79

V.	Helios-1 Mission Phase III	81
A.	General	81
B.	First Superior Conjunction	81
C.	Second Superior Conjunction	84
D.	Second Perihelion	85
E.	Spacecraft Emergency Support	85
F.	Second Inferior Conjunction	87
G.	Third Perihelion	87
VI.	DSN System Performance Helios-1 and -2	92
A.	DSN Telemetry System Performance	92
B.	DSN Command System Performance	92
C.	DSN Tracking System Performance	92
VII.	Special Support Activities	104
A.	Spaceflight Tracking and Data Network Support	104
1.	Analog Recording Tests	104
2.	Real-Time STDN Cross Support	115
B.	Receive Capability Required by German Command Station ..	120
VIII.	Conclusions	123
	Glossary	124

TABLES

1.	Near-Earth phase project requirements for launch vehicle and spacecraft telemetry data	11
2.	Near-Earth phase project requirements for radar and DSN metric data	12
3.	NETDS Titan and Centaur telemetry data support (receive and record) commitments	15
4.	NETDS Titan and Centaur telemetry data support (real-time retransmission) commitments	16

5.	NETDS spacecraft telemetry data support (receive and record and real-time retransmission)	17
6.	Summary of station support commitments and priorities for metric data	18
7.	Launch vehicle and spacecraft telemetry data RF signal lock ..	32
8.	NETDS launch vehicle telemetry performance	34
9.	Flight event times for Helios-B	36
10.	NETDS planned spacecraft real-time telemetry processing at STDN (MIL 71)	38
11.	NETDS spacecraft real-time telemetry coverage	39
12.	NETDS spacecraft real-time telemetry coverage as recognized by the MIL 71 ASU Helios-B launch	40
13.	NETDS spacecraft real-time telemetry decoding - Helios-B launch	41
14.	NEPN metric data coverage for Helios-B	42
15.	RTCS orbital elements for Helios-B	43
16.	DSN/Helios-B telecommunications test summary	49
17.	DSN/Helios-B Launch Complex 41 telecommunications test summary	55
18.	Solar conjunction data for Helios-2	70
19.	Proposed implementation schedule for Mu-II ranging support	75
20.	Helios-1 second inferior conjunction telemetry data	89
21.	Helios-1 solar conjunction, 1975	94
22.	MIL 71 baseline test results of Pioneer 11 data from Madrid STDN and DSS 61	107
23.	STDN (MIL 71) system noise temperature test results of Pioneer 11 data from Madrid STDN and DSS 61	108
24.	Madrid STDN/DSS 61 data acquisition test results	111
25.	MDR comparison test results	116
26.	DODR comparison test results	117

FIGURES

1.	Basic NETDS operational control communications interfaces and simplified data flow	7
2.	Launch vehicle telemetry configuration for Helios-B	19
3.	Helios spacecraft data retransmission	21
4.	Near-Earth phase tracking data flow	23
5.	NETDS communications configuration for Helios-B	24
6.	DSN/Helios-B compatibility test site	47
7.	Comparison of actual tuning to instructed tuning at DSS 42 ...	59
8.	DSS 42 hour angle residual	61
9.	Noncoherent/coherent downlink reacquisition	62
10.	DSS 44 angle drive failure and effect on signal level	63
11.	Proposed ranging configuration at DSS 14	74
12.	Station-spacecraft configuration	76
13.	Helios-2 trajectory, Mission Phases I and II	80
14.	Helios-1 trajectory, Mission Phase III	82
15.	Helios-1 telemetry degradation at superior conjunction	83
16.	Helios-1 Ranging Channel Test	88
17.	Helios-1 ranging problem vs VSO temperature	88
18.	Helios-1 third perihelion data	91
19.	Helios-1 average noise vs SEP angle	96
20.	Helios-1 average noise vs ESP angle	97
21.	Helios-1 average noise vs ISI	98
22.	Helios-1 first 1975 solar conjunction observed doppler noise vs ISED model	99
23.	Helios-1 second 1975 solar conjunction observed doppler noise vs ISED model	100
24.	Helios-1 first 1975 solar conjunction observed doppler noise and ISED model vs day of year	101

25.	Helios-1 second 1975 solar conjunction observed doppler noise and ISED model vs day of year	102
26.	STDN MILA/MIL 71 block diagram configuration	106
27.	DSN Goldstone Deep Space Communications Complex	119
28.	German deep space network locations	121

ABSTRACT

This report (Volume II) is in two parts. The first, Part A, summarizes Deep Space Network activities in the development of the Helios-B mission from planning in May 1975 through entry of Helios-2 into first superior conjunction (end of Mission Phase II) in May 1976. The second, Part B, covers the Deep Space Network operational support activities for Helios-1 from first superior conjunction in April 1975 through entry into third superior conjunction in May 1976.

PART A

HELIOS-B PRELAUNCH PLANNING
THROUGH END OF MISSION PHASE I

I. INTRODUCTION

A. PURPOSE

The purpose of Part A of this report is to provide a historical account of JPL Tracking and Data Acquisition (TDA) activities in the prelaunch planning and development of Helios-B through the end of mission Phase I.

B. SCOPE

Part A discusses the prelaunch and operational support provided for Helios-B by the Near-Earth Phase Network (NEPN) and the Deep Space Network (DSN).

C. HELIOS-B MISSION PLANNING

In late May 1975, the Eleventh Helios Joint Working Group Meeting (HJWGM) was held in Munich, West Germany. The principal thrust of this meeting was placed on the joint activities and mutual responsibilities and/or interfaces associated with the Helios-B launch operations at Kennedy Space Center (KSC) and the prelaunch and post-launch orbital operations. Also of great importance was the Helios-B launch date of 8 December 1975.¹ Although the launch window extended from 8 December 1975 to 7 February 1976, it was pointed out that any significant delay in the upcoming Viking launches (scheduled for August 1975) could delay the Helios-B launch. If for any reason Helios-B had to be launched after the 7 February 1976 date, the DSN would not be able to provide adequate support during the important first perihelion passage phase due to DSN commitments to support the Viking encounter of Mars. As a result it was agreed by the spacecraft, launch vehicle, and ground operations representatives that the 8 December 1975 launch date could and would be met - even though the schedule would be tight.

Also of great importance was the matter of the experimenters defining the Helios-B mission profile and the simultaneous data return from both Helios-1 and Helios-B spacecraft.

The experimenters expressed a strong desire to place the spacecraft in an orbit as close to the Sun as possible because data on the magnetic field 10 days after the Helios-1 perihelion indicated twice the expected value. For purely scientific reasons the experimenters expressed a desire for a launch date around 15 January 1976. Both the U.S. and German Helios Project and Program Manager selected a target perihelion distance of 0.29 AU. This selection, based on the experimenters desires and on data provided by the spacecraft thermal engineers, would allow for a safe first perihelion and a good chance for a second perihelion even if a launch trajectory error resulted in a 0.285-AU perihelion. This was considered especially important

¹Original launch target date. Actual launch date of 15 January 1976 was result of damage to launch pad caused by Viking B launch in September 1975.

because a late Helios-B launch or Viking problems could limit DSN 64-meter station coverage during the first perihelion passage and result in the Project being dependent on a second perihelion passage.

The simultaneous data return from two Helios spacecraft was considered to be very important and, therefore, required that special procedures be developed which would permit the DSN to monitor data from one Helios spacecraft while the German Space and Operations Center (GSOC) monitored the second Helios spacecraft.

While the entire Helios-B mission would closely parallel that of Helios-1, mission operations, however, would be markedly different during launch and Phase I operations. Unlike Helios-1, Helios-B launch and Phase I operations were to be controlled from the German Space and Operations Center and not from the Jet Propulsion Laboratory. This was to be a new launch configuration and another first in the field of outer-space exploration and cooperation. This launch configuration for Helios-B was only one indication of the ever-increasing ability of GSOC. In preparation for an unforeseen emergency, a backup Spacecraft Operations Team was to be located at JPL during Helios-B launch and Phase I activities. All Helios-B attitude and orbit determination functions would be accomplished by teams located at JPL. The DSN would continue to provide tracking support over Australia and Goldstone, while the German stations would be prime in the zero-longitude area.

Helios-B test and training were planned to start in early August with the DSN Operational Verification Tests and terminate in early December with the Mission Operations System (MOS) Operational Readiness Tests (ORTs) one week prior to launch. Intervening Simulation System and Ground Data System tests were to be performed in September. DSN Performance Demonstration Tests (PDTs) and Helios-B end-to-end testing, from the spacecraft through the Spaceflight Tracking and Data Network (STDN) (MIL 71) station at Merritt Island (MIL), Florida, were to be performed in October 1975. In early November, DSN launch and step maneuver Operational Verification Tests (OVTs) were to be conducted. DSN Helios-B test and training were to be concluded in late November with the Configuration Verification Tests (CVTs).

II. NEAR-EARTH TRACKING DATA SYSTEM

A. NETDS MANAGEMENT, INTERFACES, AND OPERATIONAL CONTROL

1. Management

To ensure adequate support for the Helios Project by the various elements of the Near-Earth Tracking and Data Systems (NETDS), the Helios Tracking and Data Systems (TDS) Manager assigned the responsibility for determining the adequacy of NETDS requirements and commitments to support Project needs to a team of JPL-Eastern Test Range (JPL-ETR) personnel stationed at Cape Canaveral AFS, Florida. In addition, this team worked in conjunction with other elements of the Near-Earth Phase Network (NEPN), Project, and Lewis Research Center (LeRC) to determine the optimum trajectory design available for providing all NETDS mandatory requirements with a minimum of NETDS resources. This team was also responsible for monitoring and participating in the implementation, configuration, and support planned by the various elements of NEPN for supporting these requirements.

The Near-Earth Phase Network comprises the resources of the Kennedy Space Center (Central Instrumentation Facility, Hangar AE Telemetry Laboratory, and Communications), Air Force Eastern Test Range (Range Instrumentation Stations, Real-Time Computing System, and Communications), 4950th Aerospace Test Wing, Wright-Patterson Air Force Base (Advanced Range Instrumentation Aircraft (ARIA)), Goddard Space Flight Center (GSFC) (Spaceflight Tracking and Data Network including the USNS Vanguard), NASA Communications Network (NASCOM), and portions of the Deep Space Network (until initial two-way DSN acquisition).

2. Interfaces

As indicated above, the Near-Earth Phase Network consists of several agencies that have interfaces between themselves and with other agencies outside the NETDS. To facilitate the necessary coordination between the various agencies, the NETDS supports three major periodically scheduled Working Group Meetings listed below.

a. Project Helios Joint Working Group Meetings. These meetings, chaired by the Project Manager, allowed coordination by the NETDS with all elements of the Project including the German Spacecraft personnel and Mission Operations System personnel. Major problems and configurations concerning the NETDS were resolved at these meetings.

b. Performance and Trajectory Guidance (P&TG) Working Group Meetings. These meetings were chaired by LeRC; NETDS supported these meetings to accomplish optimization of the launch vehicle trajectory design, when possible, for NETDS purposes and to ensure that adequate trajectory data needed by the NETDS was provided.

c. NETDS Working Group Meetings. These meetings were chaired by JPL-ETR and had as their purpose the clarification of requirements, agency coverage intervals, agency configurations, interagency interfaces, etc., supporting the NETDS.

In addition to these Working Group Meetings, the Near-Earth Launch Readiness Review was held on 7 January 1976 to establish the readiness of all elements of the NEPN for a launch on 15 January 1976 (see Footnote 1, page 3).

The day-to-day interfaces with the JPL-ETR organization and GSFC (including ARIA and Vanguard support) were conducted through the Network Support Manager. These same type activities were conducted between JPL-ETR and NASA Test Support (NTS) at KSC for AFETR and KSC support. AFETR acted as lead range for Department of Defense (DOD) ARIA support from the 4950th Test Wing at Wright-Patterson Air Force Base (WPAFB).

3. NETDS Operations Control System

The Operations Control System for the NETDS was configured to provide interfaces and communications to maintain the status, operational control, and coordination between the NETDS elements and Project management during the near-Earth phase of the launch operations. Figure 1 illustrates the NETDS operational position locations, interfaces, and voice communication links.

a. NETDS Coordinator. The NETDS Coordinator represented the TDS Manager for operational cognizance of the NETDS segment of the overall TDS function for the mission. To execute the basic responsibility of this position, the Coordinator relied heavily upon coordination with four other operational positions at the Real-Time Computing System (RTCS), Range Control Center (RCC), Building AO, and STDN MIL (MIL 71).

The NETDS Coordinator, located in the Mission Operations Center (MOC), Building AO at Cape Canaveral Air Force Station (CCAFS), monitored overall systems countdown to ensure that the NETDS operations were compatible and properly interrelated with the master countdown. The Coordinator was also required to provide the Helios Flight Team at JPL with status information of general countdown activities, to coordinate integrated NETDS operations and activities (routine or anomalous) with the other agencies, and to counsel the Helios TDS Manager on all matters related to NETDS operations during the launch.

b. Project Central Associate Test Controller. The Project Central Associate Test Controller (ATC) position was located in the Range Control Center, where the ATC interfaced directly with the AFETR Superintendent of Range Operations (SRO), the GSFC/STDN representative, and the KSC representative. This allowed the ATC a close, authoritative, monitoring capability of NETDS resources of the AFETR, KSC, and GSFC. Additionally, the ATC had available the monitoring capabilities of applicable communications networks covering the individual agency activities during the countdown as well as the specific KSC, AFETR, and GSFC networks operationally controlling the NETDS resources. The ATC worked closely with the NETDS Coordinator via a special closed-loop telephone to maintain an accurate status of the NETDS resources and to act as the agent for the NETDS Coordinator in all situations requiring operational control, particularly in nonroutine circumstances and in changing, adding, or deleting support requirements relating to the utilization of KSC, STDN, and AFETR NETDS resources.

REPRODUCIBILITY OF THE ORIGINAL PAGE IS POOR

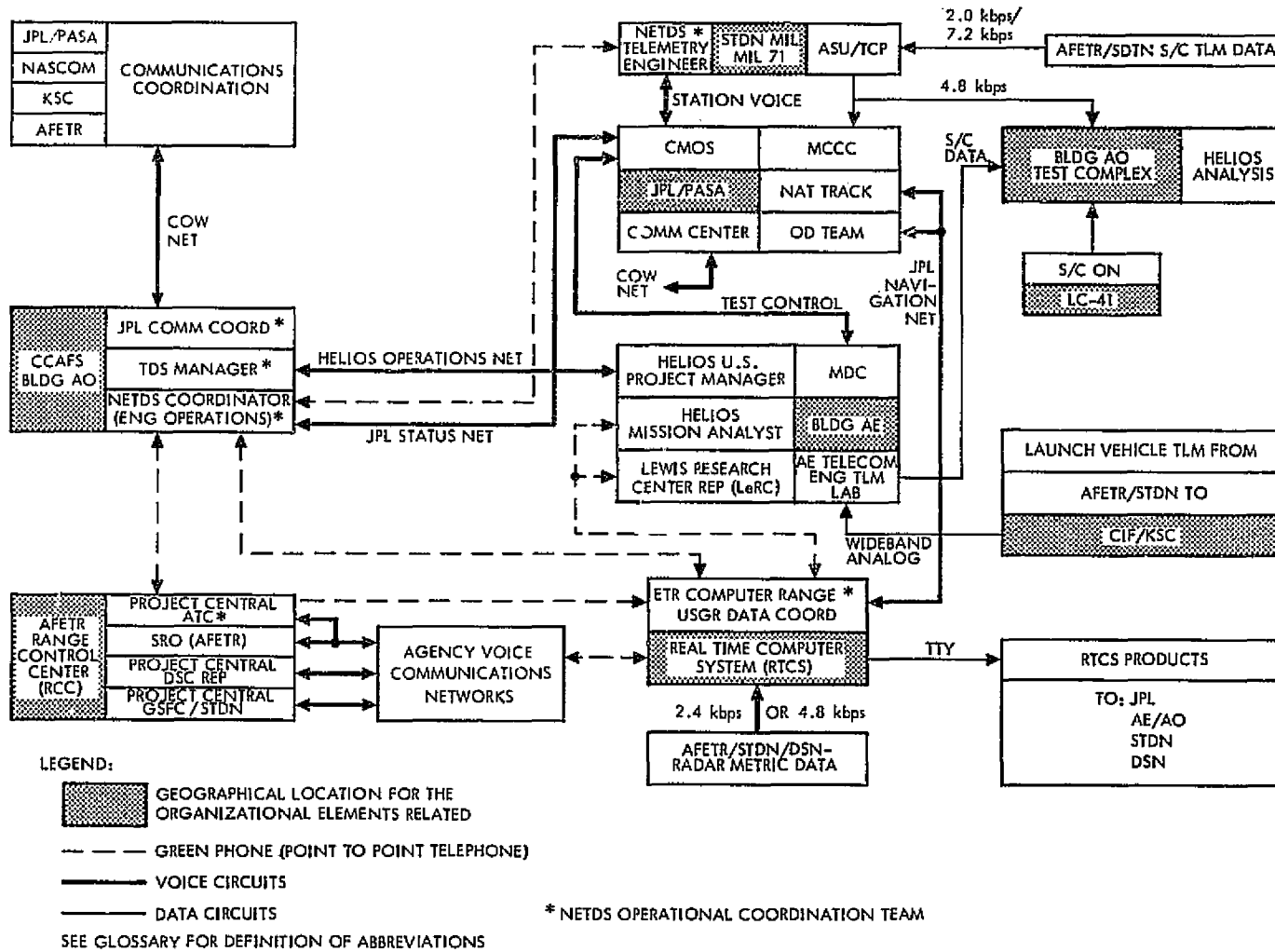

Fig. 1. Basic NETDS operational control communications interfaces and simplified data flow

c. Range User Data Coordinator. The Range User Data Coordinator (RUDC) was the Helios Project-JPL representative operationally active at the AFETR RTCS location. The major function of the RUDC was to coordinate the flow of RTCS-computed data from the RTCS to the Orbit Determination (OD) Group at Pasadena. In addition, the RUDC was the focal point for determining the need for RTCS configuration changes, reruns of data processing, program troubleshooting, or other coordination or counseling for anomalous situations. Changes in the RTCS operational configuration or procedures were officially requested by the RUDC, through the NETDS Coordinator, who requested the ATC to coordinate the changes with the SRO.

The RUDC monitored the timeliness and quality of the transmission of orbital elements and associated data to the Mission Control and Computing Center (MCCC), verifying the receipt of these messages by the Orbit Determination Group. The RUDC also provided estimates of the actual trajectory conformance with the nominal design. The RUDC additionally coordinates the updating of the acquisition predict constant parameters to be used in the RTCS and GSFC Inter-Net Predict (INP) Program, and the subsequent transmission of predict messages to supporting DSN stations.

d. NETDS Telemetry Engineer. The NETDS Telemetry Engineer was located at the STDN MIL station site on Merritt Island to coordinate all NETDS spacecraft telemetry data flow for all tests and operations that required spacecraft telemetry data be transmitted to JPL at Pasadena. The flow of data from the receiving sites (AFETR and STDN) was coordinated through the MIL 71 system to the Helios Mission Support Area (MSA) at JPL. Coordination with the NETDS Coordinator allowed the NETDS Telemetry Engineer to access the overall status of the processing and transmission of the spacecraft telemetry data stream from the sources to JPL, Pasadena, California.

e. AE Telemetry Engineer. All launch vehicle telemetry testing, launch support, and analysis of data were performed by KSC at the Central Instrumentation Facility (CIF) and Building AE Telemetry Laboratory. The AE Telemetry Engineer provided operational control of all near-Earth launch vehicle telemetry data flow and reported problems and status to the NETDS Coordinator.

f. JPL Communications Coordinator. The JPL Communications Coordinator was responsible for the overall configuration, checkout, and release of all NETDS long lines (data and voice) between the Cape Canaveral AFS and JPL. In addition, the Coordinator was also required to monitor the other data and voice circuits required within the NETDS for adequacy.

B. MISSION PLANNING

1. NETDS Data Requirements

The NETDS data requirements for Helios-B were essentially the same as specified in the Support Instrumentation Requirements Document (SIRD) for Helios-A, except for the launch vehicle telemetry requirements specified in Revision 4 of the launch vehicle addendum to the SIRD. There was, however, one significant data requirement for Helios-B that was unique: a "mandatory" requirement calling for the retransmission of valid spacecraft telemetry data, to JPL prior to launch for reformatting and retransmission in real-time to the German Space and Operations Center (GSOC) in Oberpfaffenhofen, West Germany.

Data requirements were classified by the Helios Project Office according to their importance with respect to the successful accomplishment of the mission. The following definitions of priority classifications are used in preparing the near-Earth phase requirements.

- (1) A "mandatory" classification is the minimum requirement that is essential to achieve program, mission, or test objectives for which it is specified. The program, mission, or test will not be scheduled if support is not available.
- (2) A "required" priority is support that would materially aid in achievement of all objectives and that is necessary for detailed analysis of system performance but not critical to the specified program, mission, or test.
- (3) A "desired" requirement is any support in addition to that which is mandatory or required and which may be accumulated for long-term analysis of system performance. Inability to obtain these data will not compromise the achievement of an objective.

Specific Helios-B telemetry data requirements placed on the NETDS are presented below.

a. Launch Vehicle

(1) Titan PCM/FM Link at 2287.5 MHz. A "mandatory" requirement existed for the CIF, Grand Bahama Island (GBI), and Grand Turk Island (GTK) stations and a "required" requirement for Antigua Island (ANT) to receive and record the telemetry data. Real-time retransmission was a "required" requirement from the GBI station to the CIF. The interval for these requirements was from T minus 75 minutes to Titan/Centaur separation plus 20 seconds.

(2) Centaur PCM/FM Links at 2202.5 and/or 2208.5 MHz. A "mandatory" requirement existed for CIF, GBI, ANT, Vanguard (VAN), Advanced Range Instrumentation Aircraft (ARIA) 1, ARIA 2, and ARIA 3 to receive and record the telemetry data. The "required" stations were MIL, Bermuda (BDA), and Ascension Island (STDN and AFETR) for the same data. Real-time transmission of telemetry data was a "required" requirement except for the interval of the second main engine cutoff (MECO 2) minus 60 seconds through TE 364-4 separation, which was a "mandatory" requirement. Dual ARIA coverage was a "mandatory" requirement for the interval of the second main engine start (MES 2) minus 60 seconds to MES 2 plus 130 seconds. Also a "mandatory" requirement existed during the interval MES 2 minus 120 seconds to YO² deployment plus 30 seconds. The data streams for the 2202.5- and 2208.5-MHz links were identical.

(3) TE 364-4 FM/FM Link at 2250.5 MHz. A "mandatory" requirement existed for all NETDS supporting stations to receive and record the telemetry data except for MIL, BDA, and Ascension Island (ASN) (STDN and AFETR), which had a "required" requirement. All real-time transmissions were "required"

²YO: A weighted device that is deployed during Centaur/TE 364-4 (third and fourth stages) separation which prevents recontact between the two stages.

requirements. These requirements existed for the interval of link activation to loss of signal (LOS) by the ship Vanguard. Following Centaur/TE 364-4 separation, this 2250.5-MHz link took precedence over the 2202.5/2208.5-MHz links when conflicts arose due to angular separation of Centaur and TE 364-4.

b. Spacecraft

(1) Helios Spacecraft PCM/PSK/PM Link at 2295.4 MHz. A "required" requirement existed for all NETDS supporting stations to receive and record spacecraft telemetry. Real-time transmission of spacecraft telemetry was a "required" requirement and was supported by MIL, CIF, GBI, BDA, GTK, ANT, ACN (STDN), and VAN. These requirements existed during the interval launch minus 10 minutes to DSS 42 two-way acquisition.

(2) Spacecraft Data Flow From Launch Pad to GSOC. A "mandatory" requirement existed to provide spacecraft data starting at launch minus 210 minutes. Data flow was via RF link from the launch pad to MIL 71. At MIL 71 the data were processed and put into DSN high-speed data (HSD) blocks and sent to JPL for reformatting and retransmission in real-time to the GSOC in West Germany.

c. Launch Vehicle and Spacecraft. A brief summary of the launch vehicle and spacecraft telemetry requirements for Helios-B is provided in Table 1.

In November 1975, the Lewis Research Center (LeRC) generated a requirement for the rapid return of telemetry data recorded by supporting stations, for use in a detailed analysis prior to committing the next Centaur mission. Their requirement could be implemented in one of two ways:

- (1) If the Intelsat/AC-37 launch should precede Helios, return Intelsat data by launch plus 52 hours from Antigua and Ascension.
- (2) If the Helios launch should precede Intelsat, return Helios data by launch plus 52 hours from Antigua, Ascension, the three ARIA, and the Vanguard.

As the Helios-B launch did precede that of Intelsat/AC-37, the recorded telemetry data return method (2), above, was implemented by the NETDS.

d. Metric Data. Table 2 summarizes the metric tracking data requirements for Helios-B.

Table 1. Near-Earth phase project requirements for launch vehicle and spacecraft telemetry data

Stage and link	Mandatory requirement	Required requirements	Comments
Titan (2287.5 MHz)	T-75 min to Titan/Centaur separation + 20 s	Titan/Centaur separation + 20 s loss of signal (LOS)	Entire link from GBI to KSC-CIF and ITC
Centaur (2202.5 & 2208.5 MHz)	T-75 min to MECO 1 + 180 s	Acquisition of signal (AOS) to LOS of Merritt Island, Bermuda, and Ascension	
	MES 2 -120 s thru TE 364-4 ignition		There was no real-time retransmission of this data from the ARIA, primarily due to no capability (see note).
TE 364-4 (2250.5 MHz)	T-75 min to MECO 1 + 180 s	AOS to LOS Merritt Island, Bermuda, and Ascension	
TE 364-4 (2250.5 MHz)	MES 2 - 120 s thru YO deploy + 30 s		YO deploy + 30 s to LOS is a desired requirement.
Spacecraft (2295.4 MHz)	Start of count-down to launch	Launch to initial DSN two-way acquisition (AOS to LOS of viewing stations)	Real-time retransmission of the spacecraft data was a "required" requirement. ARIA did not retransmit spacecraft data (see note).

NOTE: The ARIA did not provide real-time retransmission of data because the planned support TSPs were not in view of the LES-6 satellite, which was a required data link.

Table 2. Near-Earth phase project requirements for radar and DSN metric data

Vehicle and system	Mandatory requirements	Required requirements
Centaur beacon	Titan Stage II/Centaur separation to MECO 1 + 120 s	Launch to Titan Stage II/Centaur separation
TE 364-4 beacon		AOS to LOS Bermuda and Ascension
TE 364-4 beacon	MECO 2 to spacecraft separation + 180 s	
Spacecraft metric data (2295.4)	Injection + 70 min to injection plus 130 min	

The metric data requirements also included the real-time computation of orbital parameters of the parking orbit, Centaur orbits, spacecraft and TE 364-4 transfer orbits, and the computation of inter-net predicts for use in acquisition by DSSs 42, 44, and 61.

2. NETDS Trajectory Design

The design of the Helios-B trajectories to optimize the NETDS resources available was somewhat simpler than that for Helios-A. One reason was that the Helios-B trajectories were similar to those of Helios-A, and, therefore, it was known from the start in what area of the Helios-B trajectory space to concentrate the detailed analysis.

In June 1975, the Project Managers decided on a 0.29-AU perihelion orbit for Helios-B. The launch opportunity at that time was agreed by all agencies concerned to be between 3 December 1975 and 15 February 1976. One-hour daily launch windows were targeted for these days with closing launch azimuths of 108 degrees. The outgoing target declinations for these trajectories ranged between -5 and +18 degrees.

The STDN Johannesburg and Tananarive sites were deactivated between Helios-A and -B. Therefore, all downrange mandatory vehicle burn data were planned to be supported by three ARIA and the Vanguard.

The AFETR had planned for a range shutdown over the Christmas holidays as well as an ARIA stand-down period from mid-December to mid-January, for transfer of the aircraft to Wright-Patterson Air Force Base (WPAFB). Both of these planned activities impacted launching Helios during this time period

and a compromise agreement between all parties concerned eliminated 24 December 1975 through 9 January 1976 as possible launch days.

The launch of Viking B on 9 September caused considerable fire damage to the electronic vans at the launch pad. As a result of the problems associated with the damage, the U.S. and German Project Managers decided on 15 January 1976 as the earliest feasible launch date for the Helios-B spacecraft.

Because of this delay in earliest feasible launch date and the problems with the DSN supporting both Viking orbital operations and the perihelion date of Helios-B, LeRC investigated the possibilities of additional launch day/perihelion arrival day combinations into February. LeRC developed what was known as the "fast transfer" plan for launch days 8 through 29 February 1976. The fast transfer plan consisted of using some of the launch vehicle excess propellants to increase the Helios-B spacecraft velocity so as to arrive at perihelion at the same date as it would for a 7 February 1976 launch date.

The Project directed that the "fast transfer" trajectories be used for all days after 7 February 1976. The major impact upon the NETDS was the longer duration of the Centaur second burn and the corresponding additional support time required of ARIA 2.

The NETDS developed a plan to support the "fast transfer" trajectories in December and started implementation of this plan in December and January to ensure readiness of NEPN support if these launch days became necessary. Included in this plan was a system for delivering the new ARIA flight plans and acquisition data downrange to the ARIA at Johannesburg and Mauritius.

3. NETDS Resource Commitments

The basic commitments of resources to furnish facilities, services, data, and related support for the preflight testing, launch, and post-launch operations were contained in the Project Helios NASA Support Plan (NSP). Details of these commitments were contained in documents generated by the respective elements of the NETDS:

- (1) Goddard Space Flight Center's Network Operations Support Plan for the Helios-B Mission.
- (2) Air Force Eastern Test Range's Operations Directives (4300 series), which included commitments for ARIA.
- (3) Kennedy Space Center's Helios Support Document No. 4300.
- (4) TDS Near-Earth Phase Operations Plan for Helios-B Mission 1976, Volume I, Launch Operations Plan.

The data coverage commitments, together with the data intervals actually acquired, are contained in Subsection E of this section.

The AFETR Real-Time Computing System (RTCS) was committed to compute (in real-time) orbital elements, standard orbital parameter messages, internet predicts, and I-matrices. The KSC Central Instrumentation Facility was

committed to compute orbital elements and standard orbital parameter messages for the Centaur parking orbit and transfer orbits using telemetered Centaur guidance data as a data source.

To support the requirement for rapid return of data recorded by ARIA, Ascension, and Antigua, AFETR committed:

- (1) For a mission launched during 15 January through 10 February 1976: one ARIA return to Wright-Patterson AFB and a T minus 39 aircraft delivery at Patrick AFB, by T plus 54 hours, of Ascension (AFETR and STDN) and all ARIA tapes.
- (2) Antigua data would be returned via the scheduled downrange aircraft.

To support the requirement for rapid return of data recorded by the USNS Vanguard, GSFC committed to send a courier via commercial carrier from Mauritius to the United States. The Vanguard was to sail to Mauritius shortly after the Helios-B launch.

NASCOM committed the required voice, data, and teletype circuits requested through the standard forecast and weekly scheduling procedures.

Tables 3, 4, 5, and 6 list the telemetry and metric tracking facilities and their respective data priority classification commitments.

Table 3. NETDS Titan and Centaur telemetry data support
(receive and record) commitments

Telemetry site	Titan link (2287.5 MHz)	Centaur PCM/FM link (2202.5 and/or 2208.5 MHz)	TE 364-4 FM/FM link (2250.5 MHz)
CIF (KSC)	M	M	M
Merritt Island (STDN)		R	R
Grand Bahama Island (AFETR)	M	M	M
Bermuda (STDN)		R	R
Grand Turk (AFETR)	M	M	M
Antigua (AFETR)	R	M	M
Ascension (STDN)		R	R
Ascension (AFETR)		R	R
ARIA 1 (AFETR)		M	M
ARIA 2 (AFETR)		M	M
ARIA 3 (AFETR)		M	M
Vanguard (STDN)		M	M

M = mandatory requirement
R = required requirement
D = desired requirement

Table 4. NETDS Titan and Centaur telemetry data support
(real-time retransmission) commitments

Telemetry site	Titan link (2287.5 MHz)	Centaur PCM/FM link (2202.5 and/or 2208.5 MHz)	TE 364-4 FM/FM link (2250.5 MHz)
CIF (KSC)	R	R	
Merritt Island (STDN)		R	R
Grand Bahama Island (AFETR)	R	R	
Bermuda (STDN)		R	R
Grand Turk (AFETR)			
Antigua (AFETR)		R	R
Ascension (STDN)		R	R
Ascension (AFETR)			R
Vanguard (STDN)		M	R

M = mandatory requirement
R = required requirement

Table 5. NETDS spacecraft telemetry data support (receive and record and real-time retransmission)

Telemetry site	Spacecraft telemetry 2295.4 MHz	Comments
MIL 71 (STDN)	M/R	Mandatory for prelaunch*
CIF (KSC)	R	*
Merritt Island (STDN)	R	*
Grand Bahama Island (AFETR)	R	*
Bermuda (STDN)	R	*
Grand Turk (AFETR)	R	*
Antigua (AFETR)	R	*
Ascension (STDN)	R	*
Ascension (AFETR)	R	
ARIA 1 (AFETR)	R	
ARIA 2 (AFETR)	R	
ARIA 3 (AFETR)	R	
Vanguard (STDN)	R	*
DSS 42 (DSN)**	M	*

M = mandatory requirement

R = required requirement

*Real-time retransmission of spacecraft data committed

**DSS 44 backup to DSS 42

Table 6. Summary of station support commitments and priorities for metric data

Station	C-band Centaur beacon	C-band TE 364-4 beacon	Comments
Merritt Island	M		
Patrick AFB	M		
Cape Canaveral	R		
Grand Turk		R	See note
Bermuda		R	
Antigua	M		
Ascension (12.16 & 12.15)		R	
Vanguard		M	

M = mandatory requirements
R = required requirements

NOTE: Grand Turk support was canceled following slip of Helios-B to January 1976.

C. IMPLEMENTATION AND CONFIGURATIONS

1. Launch Vehicle Telemetry

The Centaur 2208.5-MHz FM/FM telemetry link used for the Helios-A mission was deleted for the Helios-B mission. This 2208.5-MHz link then became a redundant link to the 2202.5-MHz PCM/FM link in place of the 2215.5-MHz link used for Helios-A. No other new implementations were performed at any of the near-Earth stations for the Helios-B mission.

Johannesburg and Tananarive were deactivated before Helios-B. Except for these stations, the near-Earth station configurations (both hardware and software) remained the same as for the Helios-A mission. The configuration for the launch vehicle real-time telemetry transmission plan is shown in Fig. 2. No real-time retransmission of launch vehicle telemetry data was provided by ARIA, but they were configured to read out the MES 2 and MECO 2 mark events in near real-time.

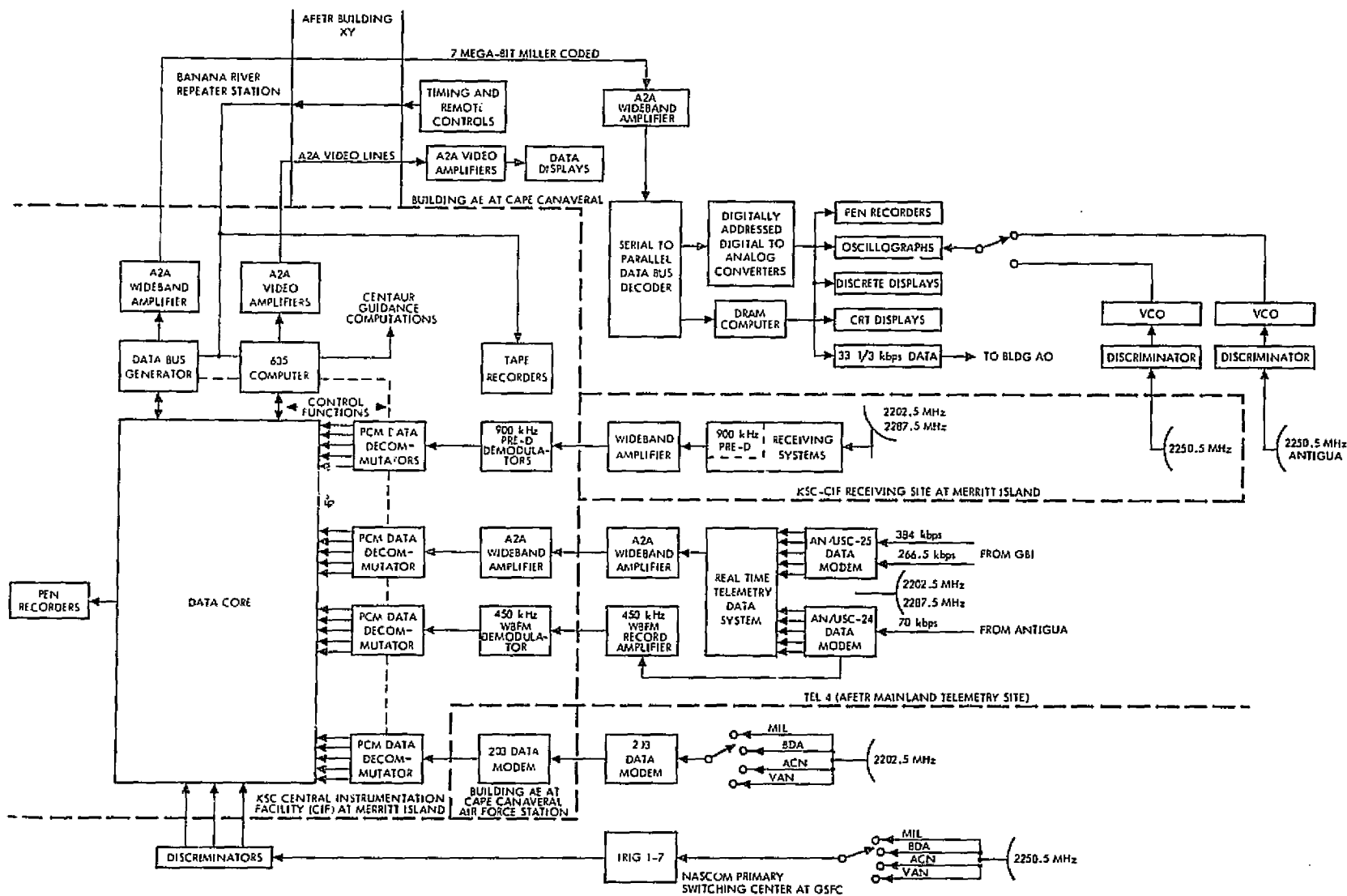

Fig. 2. Launch vehicle telemetry configuration for Helios-B

The STDN configurations are documented in STDN No. 601/Helios-B, Network Operations Support Plan for the Helios-B Mission, dated November 1975. The AFETR stations configurations are documented in AFETR Operations Directive No. 4300, Helios Launch, dated 19 December 1975.

2. Spacecraft Telemetry

No new implementations were performed at any of the near-Earth stations specifically for the Helios-B mission. At the Eleventh Joint Working Group Meeting for Project Helios held in May 1975, the NETDS recommended that the spacecraft 128-bps coded mode used for Helios-A be changed to 128-bps uncoded mode for Helios-B. This was requested because the coded mode with the long frame lengths caused a 90-second loss of real-time data at the MOS area every time there was a momentary loss of the spacecraft downlink at MIL 71. Unfortunately, this change could not be easily accommodated by the Helios Spacecraft Manager, and, therefore, the recommendation was not implemented.

The configuration (both hardware and software) of near-Earth stations remained basically the same as for the Helios-A launch with the exception of support from Johannesburg, Tananarive, and Carnarvon. However, to minimize for Helios-B the real-time spacecraft data retransmission problem encountered on the Helios-A mission, the following two changes were integrated into the near-earth system at MIL 71. First, isolation amplifiers and data regenerators were added to the input data terminals of the MIL 71 Automatic Switching Unit (ASU). The second improvement involved the development of a plan to minimize the switching of data by the MIL 71 ASU. This helped to eliminate interruptions in spacecraft data and decreased the loss of data at the MOS area because of the 90-second lockup time needed by the MIL 71 decoder.

The ARIA were not configured to retransmit spacecraft data for Helios-B because their support locations were out of view of the LES-6 satellite, and the ARIA communications terminals were not compatible with the Indian Ocean communications satellites. The configuration for the telemetry real-time transmission plan is shown in Fig. 3.

The STDN configurations are documented in STDN No. 601/Helios-B, Network Operations Support Plan for the Helios-B Mission, dated November 1975. The AFETR stations configurations are documented in AFETR Operations Directive No. 4300, Helios Launch, dated 19 December 1975.

3. Metric Data

Only a minor implementation change in the metric data occurred between Helios-A and -B. This involved the updating of the DSS 42 HSD format from JPL DSN format TRK-2-8 to TRK-2-11. This change was accomplished before the Viking missions, and the TRK-2-11 format was processed at the AFETR RTCS for the Viking missions as well as for Helios-B.

The only configuration change between Helios-A and -B was the loss of metric data due to the deactivation of Tananarive. The Vanguard metric data replaced these data for Helios-B.

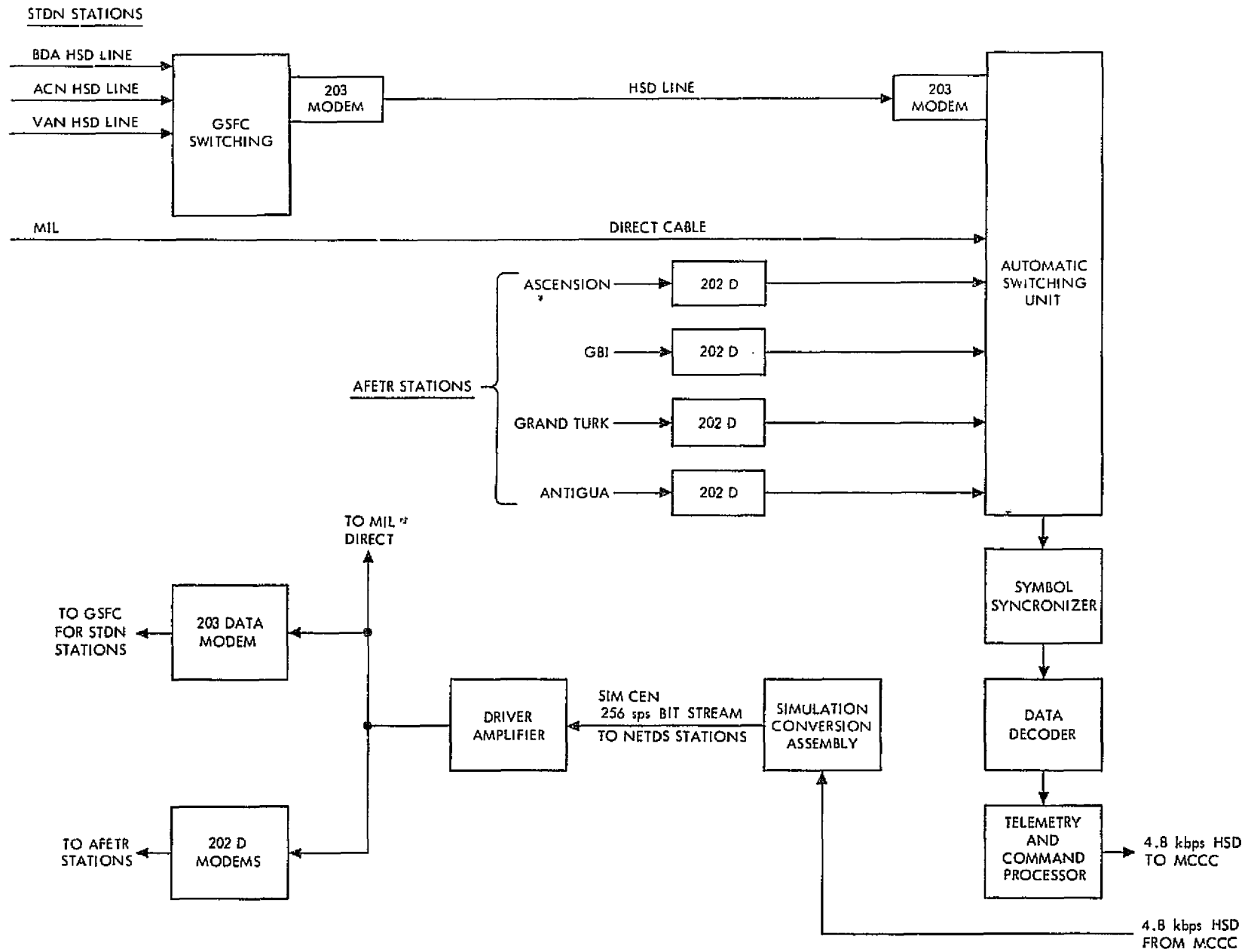

Fig. 3. Helios spacecraft data retransmission

The configuration for the metric data flow and associated orbital element and predict computations is shown in Fig. 4.

4. Communications

The NETDS Communications System was configured to provide voice and data communications between all supporting elements of the NETDS and made use of existing NASA and Air Force Communications Networks in order to provide this service. Communication configuration of voice and data circuits in support of the NETDS is shown in Fig. 5.

The NETDS Communications System was implemented for End-to-End Compatibility Test 5 and supported the Operational Demonstration Test (ODT) 1, ODT 2, Operational Readiness Test (ORT) 1, and launch, while the NETDS communications personnel provided all necessary scheduling and operational control during times the system was active for test and launch support.

D. PRELAUNCH TESTING

1. NETDS Testing

Near-Earth testing, in preparation for Project-level testing, was accomplished for the launch vehicle telemetry, spacecraft telemetry, and metric data configurations. Launch vehicle and metric data testings were minimal, but spacecraft telemetry testing was extensive, consisting of six tests. The launch vehicle telemetry testing consisted of verifying the AFETR and STDN station software for supporting the Project-level tests and launch. Both the AFETR and STDN softwares were verified; however, the STDN software was received at the station and verified, somewhat later than originally scheduled. The metric data verification tests were part of the Near-Earth Phase Test Plan and consisted of checking out the DSS 42 high-speed data format (TRK-2-11) at the AFETR RTCS and processing the inter-net predicts for DSN stations. Both of these tests were conducted at the RTCS.

The inter-net predict tests were successfully completed and verified as planned.

The DSN high-speed data to be used for launch (TRK-2-11 format, DDT 114 octal with RVI = 0) checked out at the RTCS during the scheduled test with JPL simulation. The other format available to the RTCS (TRK-2-11 format, DDT 106 octal with RVI = 0) could not be processed during this test, however. The RTCS program was modified to handle this format, checked out, and verified before the first Project test.

The six NETDS spacecraft telemetry tests were conducted as part of the Near-Earth Phase Test Plan and are summarized below.

a. Test 1. STDN/AFETR and NETDS Compatibility Test With a Spacecraft Tape.

(1) Objective. To verify that (a) STDN MILA and AFETR TEL 4 could demodulate the spacecraft phase-shift-keying (PSK) subcarrier (32.768 kHz), and (b) STDN MILA, TEL 4, and the ASU (Automatic Switching Unit at MIL 71) could obtain frame synchronization on the 16-symbol pseudo-sync pattern.

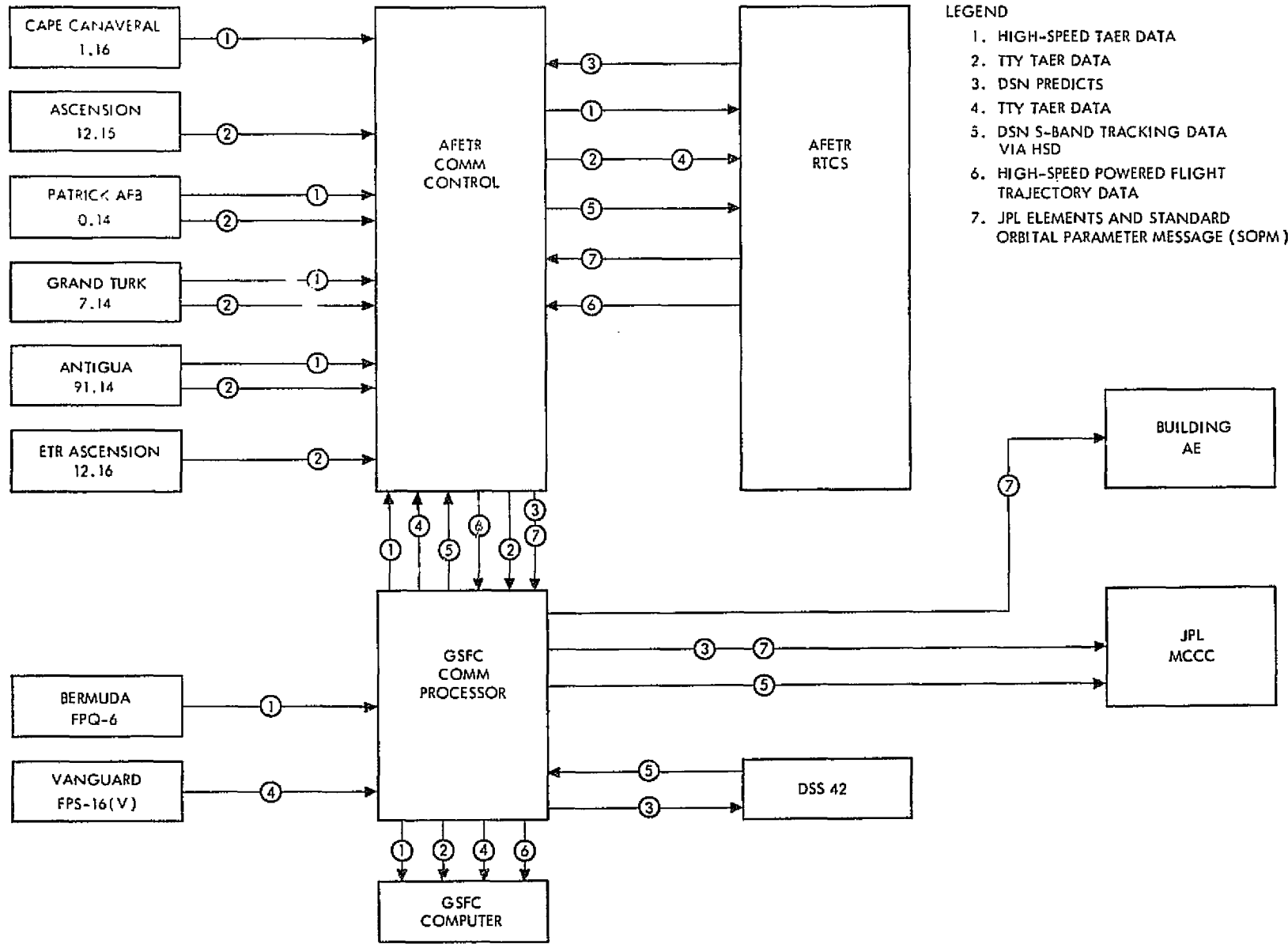

Fig. 4. Near-Earth phase tracking data flow

REPRODUCIBILITY OF THE ORIGINAL PAGE IS POOR

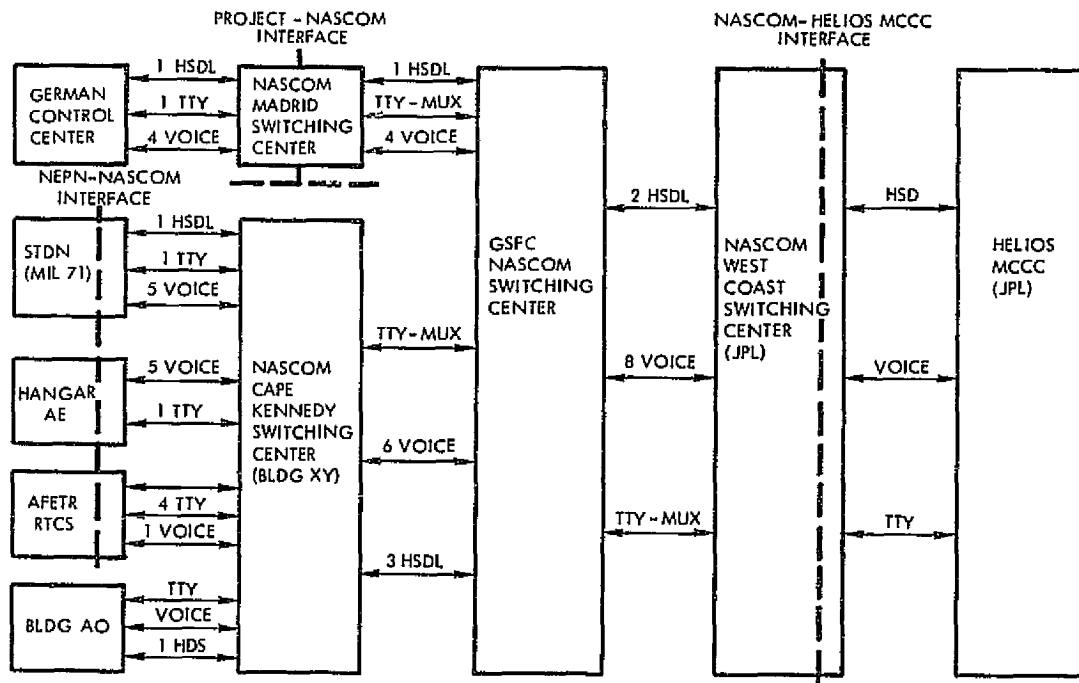

Fig. 5. NETDS communications configuration for Helios-B

(2) Test Description

- (a) STDN MILA playback the spacecraft signal tape to establish subcarrier demodulation and pseudo-frame sync detection.
- (b) MILA remote the spacecraft symbol stream to the MIL 71 ASU.
- (c) MIL 71 establish pseudo-frame sync on the symbol stream using the ASU capability.
- (d) TEL 4 repeat steps (a) and (b).
- (e) MIL 71 repeat step (c) on the TEL 4 symbol stream.

(3) Test Results. The test was performed on 21 October 1975 in accordance with the planned sequence of events. No problems were experienced.

b. Test 2. STDN and ETR Data Transmission Demonstration

(1) Objective. To demonstrate that STDN/MILA and ETR/TEL 4 could receive the simulated 256-symbol per second (sps) data stream, obtain pseudo-frame synchronization, and retransmit the data stream to MIL 71 without any major data outages.

(2) Test Description

- (a) MIL 71 generated a 256-sps static pattern in the Simulation Conversion Assembly (SCA), transmitted the data to the ASU, and verified that the bit error rate (BER) was 10^{-6} or better.
- (b) MIL 71 transmitted the SCA data to MILA on a 7.2-kbps asynchronously clock 203 data modem.
- (c) MILA obtained pseudo-frame sync on the 256-sps data stream and returned the data to MIL 71 via a 203 data modem.
- (d) MIL 71 verified the BER of the looped back data was 2×10^{-3} or better at the ASU.
- (e) Repeated steps (c) and (d) utilizing TEL 4 and 202D modems for transmission at 256 sps.

(3) Test Results. The test was performed on 28 October 1975 with no problems.

c. Test 3. STDN and AFETR RF Compatibility Test With the Helios-B Spacecraft.

(1) Objective. To verify that MILA and TEL 4 could receive the spacecraft RF signal and recover the 256-sps data stream.

(2) Test Description

- (a) Helios spacecraft was configured in a launch mode and radiated the RF signal from Building AO.
- (b) MILA and TEL 4 received the spacecraft RF signal, demodulated the subcarrier, and obtained pseudo-frame sync on the telemetry data stream.
- (c) MILA and TEL 4 transmitted the telemetry data stream to the MIL 71 ASU and obtained pseudo-frame sync.
- (d) MILA and TEL 4 made an analog magnetic tape recording of the spacecraft data and furnished it to their respective network stations for simulation data in future tests.

(3) Test Results. The test was performed in conjunction with Test 4 of this plan on 7 November 1975. No problems were experienced during the performance of this test.

d. Test 4. Spacecraft/NEPN/MCCC/MOS/GSOC End-to-End Compatibility Validation

(1) Objective. To validate that the NEPN data received from a flight spacecraft was 100% correct when displayed at the MOS.

(2) Test Description

- (a) Helios spacecraft was configured in a launch mode and radiating the RF signal from Building AO.
- (b) MILA and TEL 4 received the spacecraft RF signal, demodulated the subcarrier, and obtained pseudo-frame sync in the 256-sps telemetry data stream (128 bits per second (bps) coded).
- (c) MILA and TEL 4 transmitted the telemetry data stream to MIL 71.
- (d) MIL 71 obtained frame sync on the data stream and provided to the DSN Telemetry Processing System.
- (e) MIL 71 transmitted the telemetry data to MCCC on the 4.8 kbps high-speed data line (HSDL).
- (f) MCCC verified block sync and frame sync, displayed the data to MOS in launch configuration.
- (g) MCCC reformatted the data and transmitted to GSOC via high-speed data line.
- (h) Both MOS and GSOC evaluated the data for 100% correctness by verifying every parameter/bit state with the Spacecraft Test Team in Building AO.

(3) Test Results. The test was performed on 7 November 1975 and no problems were encountered.

e. Test 5. STDN Station Validation

(1) Objective. To verify that GSFC and each participating STDN station is ready to support the mission test exercises.

(2) Test Description

- (a) MILA, BDA, ACN, and VAN generated a 256-sps coded format 4 engineering data stream using their respective simulators.
- (b) Each station verified pseudo-frame sync in the locally generated symbol stream.
- (c) Each station transmitted the locally generated symbol stream to Network Support Team (NST) telemetry at GSFC.
- (d) NST telemetry selected one station and transmitted the data to MIL 71 on a 7.2-kbps HSDL.
- (e) MIL 71 obtained pseudo-frame sync on the incoming data stream.
- (f) NST telemetry switched the data line to the next station downline and MIL 71 verified frame sync until all stations were validated.
- (g) Each station removed their station simulator and load analog tape made during Test 3 and played back the spacecraft data.
- (h) Repeated steps (c) through (f) for each station.

(3) Test Results. All STDN stations participated in the test except the USNS Vanguard on 30 December 1975. The USNS Vanguard participated in the test on 5 January 1976. No problems were experienced during the validations.

f. Test 6. AFETR Station Validation

(1) Objective. To verify that all participating AFETR stations are ready to support the mission test exercises.

(2) Test Description

- (a) MIL 71 generated a simulated 256-sps coded format 4 engineering symbol stream in the SCA (stand alone).
- (b) MIL 71 verified pseudo-frame sync in the SCA symbol stream using the ASU initialized to print out every frame sync status change.

- (c) TEL 4 generated a 256-sps coded format 4 engineering symbol stream using the station simulator.
- (d) TEL 4 verified pseudo-frame sync in the locally generated symbol stream in step (c), above.
- (e) TEL 4 transmitted the locally generated symbol stream to MIL 71 using 202D modem.
- (f) MIL 71 verified pseudo-frame sync in the symbol stream from TEL 4 using the ASU.
- (g) TEL 4 loaded spacecraft data tape made from Test 3 and played back the spacecraft data.
- (h) TEL 4 verified pseudo-frame sync from the tape playback data and regenerated the symbol stream in a pulse code modulation (PCM) decommutator/bit synchronizer.
- (i) TEL 4 transmitted the regenerated symbol stream to MIL 71 on the 202D modem circuit.
- (j) MIL 71 verified pseudo-frame sync in the tape playback symbol stream using the ASU.
- (k) Repeated steps (c) through (j) with GBI, GTK, and ANT.

(3) Test Results. The test was performed with all AFETR stations on 17 December 1975. No problems were experienced during this validation test.

2. End-to-End Compatibility Test 5

This project test was successfully supported on 7 November 1975, and was considered the major NETDS spacecraft verification test. The NETDS supported this test as spacecraft Test 4 and is described in detail in Subsection 1, above.

3. Operational Demonstration Test 1

MIL 71 and the RTCS were the only two elements of the near-Earth phase to support ODT 1 on 25-26 November 1975. MIL 71 provided spacecraft telemetry data to the MOS area, and the RTCS provided orbital elements and predicts to the orbit determination and DSN predict areas at JPL. The objective of this test was to provide training to all MOS participants for the launch sequence.

The RTCS successfully provided all the orbital elements requested in the timeline outlined in the Near-Earth Sequence of Events (SOE). No Near-Earth Telemetry Stations actually participated in the test. MIL 71 simulated the data flow from all downrange stations during the simulated launch plus (L+) count.

The test started with the Data Transfer Test to MCCC at 2245 GMT and was completed at 2315 GMT. At this time the Simulation Center simulated the spacecraft throughout the remainder of the test. Simulated liftoff occurred at 01:16:06 GMT and MIL 71 looped back the simulated data from the Simulation Center through the ASU as it would during plus count activities.

a. Test Results. No problems were experienced by either MIL 71 or the RTCS during this test.

4. Operational Demonstration Test 2

This test was performed as scheduled on 5-6 January 1976. NETDS elements provided full participation by simulating real-time spacecraft and launch vehicle telemetry data, and real-time metric tracking data. The trajectory simulated was that for the opening of the launch window on the first launch day (0534 GMT, January 15, 1976). The test had to be performed in real-time because of the constraint at the German Space and Operations Center which could not simulate nonreal-time.

The countdown proceeded without any significant difficulties until the German Space and Operations Center (GSOC) experienced a problem and called an unscheduled "hold" approximately 10 minutes prior to the simulated liftoff time. The duration of the "hold" was initially estimated to last 1 hour; subsequently the duration was reduced to 30 minutes for the NETDS. All elements were advised that the effect of this unscheduled "hold" was that the simulated data, both telemetry and metric, would remain time-tagged to the originally simulated trajectory of 0534 GMT. The only exception would be for the radar at Ascension, which depended upon a real-time inter-range vector (IRV) from the Real-Time Computing System as a basis for generating its data. The Goddard Real-Time System was the user of this data. Since the Ascension radar data would not be consistent with the other simulated radar data, that station's radar was released from support. The USNS Vanguard responded to a real-time request to extend its transmission of simulated spacecraft telemetry data to overlap DSS 42's revised acquisition of signal (AOS), which was delayed as a result of the unscheduled "hold."

MIL 71 started activities by performing the Data Transfer Test to MCCC at 0152 GMT until 0214 GMT. At 0217 GMT, the JPL Simulation Center was flowing simulated spacecraft data at the 256-sps data rate, and MIL 71 was processing the data and transmitting back to MCCC. The STDN station spacecraft validation was started at 0230 GMT. The STDN stations were all validated at 0343 GMT, and the AFETR station spacecraft validation was started. The AFETR validation tests were completed at 0411 GMT. The Chief of Mission Operations Support (CMOS) notified MIL 71 that a hold was being called at 0524 GMT. The count was picked up after a 30-minute hold, and liftoff occurred at 0604 GMT. All near-Earth stations looped back the simulated spacecraft data at their respective AOS/LOS times.

a. Test Results. The MIL 71 Telemetry and Command Processor (TCP) Alpha was down during the entire test and did not process any data. TCP Beta was utilized without problems but no backup capability existed. No problems were experienced with spacecraft data except for approximately 7 minutes of data, which was lost from USNS Vanguard because they had their station simulator on line rather than the looped-back data. No problems

of any significance occurred with the metric data and RTCS support. The launch vehicle telemetry data flow from Antigua was not checked out when scheduled because of nonoperating equipment at Antigua, and the USNS Vanguard had a bad FM/FM data tape. The Antigua data were subsequently checked out, and a new FM/FM data tape for the USNS Vanguard was recommended.

The NETDS support of this test was considered an overall success by the NETDS and Project.

5. Operational Readiness Test

a. Objective. To verify that all mission supporting facilities were ready to support the launch.

b. Test Activity. The test was performed on 11-12 January 1976. The test sequence was to simulate the actual launch day of 15 January 1976, with a liftoff time of 0534 GMT. The NETDS compiled a detailed updated SOE, including mark events, for this Operational Readiness Test (ORT) that was planned to be also applicable for the launch. NETDS elements provided project support by simulating real-time spacecraft telemetry and real-time metric tracking data. Launch vehicle telemetry data were not simulated due to other operational commitments and to the fact that data flow had been successfully exercised previously. Simulated mark events and other launch vehicle telemetry related items were provided by the NETDS to the CMOS at JPL.

The RTCS provided all the items required in the simulated launch minus and plus counts with the exception of the computation of the Centaur post-deflection orbit. This was not provided because there were no valid Centaur post-deflection metric data available.

All NEPN facilities participated in spacecraft telemetry data flow. MIL 71 activities started by performing the Data Transfer Test to MCCC at 0512 GMT, and the MCCC/GSOC validation was completed at 0224 GMT. The JPL Simulation Center started flowing data, and MIL 71 looped the data back at 0234 GMT. The STDN station validation was started at 0224 GMT. The STDN station validation was completed at 0337 GMT, and the AFETR station validation was started. The AFETR station validation was completed at 0436 GMT. The simulated data were switched to MILA on TCP Beta at 0524 GMT. Simulated liftoff occurred at 0534, and all near-Earth stations looped back the simulated data at their respective AOS times.

c. Test Results. During the simulated launch plus count and before BDA acquisition, a short occurred on the 7.2-kbps data line from GSFC to MIL 71. Therefore, no data were received in real-time from Bermuda, Ascension, or the USNS Vanguard. The simulated data were, however, looped back to MCCC at MIL 71. Investigations the next day determined that a bad jack on the HSDL input to a tape recorder at MIL 71 was the problem. It was corrected and tested. The flow of orbital elements and predicts from the RTCS and mark events and status from AO occurred as planned. The NETDS was considered "green" for launch after the bad jack was found and corrected at MIL 71.

E. LAUNCH SUPPORT

In general, the NETDS remained operational throughout the launch countdown on 15 January 1976. However, at approximately 35 minutes prior to launch, the Aircraft Operations Control Center at Wright-Patterson AFB advised that radio contact with the airborne ARIA had been lost. A planned backup voice circuit to the aircraft via the USNS Vanguard was then activated to relay the countdown information and operational instructions.

Then, at 05:34:36 GMT, the Helios-B spacecraft was successfully launched from Launch Complex 41 at the Cape Canaveral Air Force Station.

1. Launch Vehicle Telemetry Data

Most of the Near-Earth Phase Network (NEPN) stations met or exceeded the committed support of the launch vehicle telemetry links for Helios-B. The noticeable exception was ARIA 1, which did not support nearly as well as predicted. Table 7 provides the launch vehicle telemetry RF signal lock as observed by the NETDS stations. Table 8 is a summary of the usable data on the NEPN station data tapes as evaluated at the AE telemetry lab after the launch. This table is a complete listing of the stations including ARIA 4, except for Bermuda and Grand Turk.

All Helios primary mission mark events (mark 0 through 20) were read out by one or more of the NEPN stations. A list of the nominal versus actual mark events is provided in Table 9. The performance of the Titan vehicle was slightly less than predicted, and this accounted for the 10- to 13-second difference in actual versus predicted time of mark events 10 through 13 and the approximate 5-second difference in mark events 13 through 20.

The launch phase was very nominal and almost all of the supporting NETDS stations equalled or exceeded their commitments. The levels of telemetry support by ARIA 1, and of radar tracking support by the radars at Antigua and on the USNS Vanguard, were less than expected, but did not cause any major problems in providing the required near-Earth launch information.

All mission mark events were obtained by the NETDS stations with many of the mark events being reported by more than one station.

As on the Helios-A and Viking missions, the telemetry support by ARIA indicated that the state of the art of data acquisition, together with unique operational problems, is such that backup aircraft are justified and required in support of telemetry data requirements which are truly "mandatory."

The expedited return of data was accomplished essentially on time with respect to the commitments made.

2. Spacecraft Telemetry Support

The Helios-B countdown activities at STDN (MIL 71) began on 14 January 1976 at 2025 GMT. By 2329 GMT, the station was locked to the spacecraft RF downlink signal level of -130 dBm and to the telemetry at the 2048-bps coded mode. A Data Transfer Test from STDN (MIL 71) to MCCC (Pasadena) began at 0115 GMT and successfully completed at 0136 GMT. Between 0217 GMT and 0237 GMT, all supporting STDN and AFETR station validations were completed.

Table 7. Launch vehicle and spacecraft telemetry data RF signal lock

Links (MHz)	NOM	ACT	NOM	ACT	NOM	ACT	NOM	ACT
	AOS	AOS (L + seconds)	LOS	LOS	AOS	AOS (L + seconds)	LOS	LOS
	CIF				Merritt Island			
2202.5	0	0	450	490	0	0	480	485
2208.5	0	0	450	490	0	0	480	485
2287.5	0	0	450	490	0	0	480	485
2250.5	0	0	450	380	0	0	480	485
2295.4	0	0	450	490	0	0	480	485
	Grand Bahama				Bermuda			
2202.5	48	35	511	525	285	265	610	665
2208.5	48	35	511	525	285	265	610	660
2287.5	48	35	474 ^a	525	285	264	610	666
2250.5	48	35	511	525	285	272	610	657
2295.4	48	35	511	430	285	276	610	662
	Grand Turk				Antigua			
2202.5	230	218	620	633	413	395	760	795
2208.5	230	218	620	633	413	395	760	795
2287.5	230	187	474 ^a	528	405	409	474 ^a	758
2250.5	230	255	620	604	414	395	760	795
2295.4	230	255	620	604	414	395	760	780
	Ascension-AFETR				Ascension-STDN			
2202.5	1255	1243	1580	1629	1240	1235	1570	1631
2208.5	1255	1243	1580	1629	1240	1235	1570	1631
2250.5	1255	1243	1580	1629	1240	1235	1570	1651
2295.4	1270	1243	1580	1540	1240	1235	1570	1651

REPRODUCIBILITY OF THE
ORIGINAL PAGE IS POOR

Table 7 (contd)

Links (MHz)	NOM	ACT	NOM	ACT	NOM	ACT	NOM	ACT
	AOS	AOS	LOS	LOS	AOS	AOS	LOS	LOS
	(L + seconds)				(L + seconds)			
	ARIA 1				ARIA 1			
2202.5 ^b	2120	2024	2400	2469	2120	2044	2400	2477
2208.5 ^b	2120	2024	2400	2469	2120	2044	2400	2477
2250.5 ^b	2120	2024	2400	2469	2120	1960	2400	2320
2295.4 ^b	2120	2024	2400	2469	2120	2034	2400	2325
	ARIA 2				Vanguard			
2202.5	2385	2371	2670	2860	2445	2438	3165	3270
2208.5	2385	2365	2670	2860	2445	2438	3165	3270
2250.5	2385	2336	2670	2860	2445	2438	3165	2908
2295.4	2385	2336	2670	2860	2445	2438	3165	3486

^aCommitted only to Titan/Centaur separation.

^bARIA 1 only had 55 seconds of Decom lock during the pass. However, evaluation of the tape at AE indicated ARIA 1 had usable data between 2314 and 2476 seconds.

NOTE: ARIA 4 was not a scheduled aircraft for Helios-B. ARIA 4 was in transit for CTS launch and tracked Helios as an engineering test, and furnished the tapes to the Helios Project. Analysis of the ARIA 4 tape showed that the launch vehicle and spacecraft telemetry data were valid from 790 to 1228 seconds.

Table 8. NETDS launch vehicle telemetry performance
 (as determined by AE evaluation of station tapes)

Station	Planned times ^a		Actual times ^a		Percent data recovered (actual/planned)
	AOS	LOS	AOS	LOS	
CIF	0	450	0	500	$\frac{500}{450} = 111\%$
MLA	0	450	0	490	$\frac{490}{450} = 108\%$
GBI	75	495	38	540	$\frac{502}{495} = 101\%$
ANT	450	745	405	790	$\frac{405}{295} = 137\%$
ARIA 4 ^b	-	-	790	1228	$\frac{438}{0} = -$
ACN	1280	1570	1240	1670	$\frac{430}{290} = 148\%$
ASC	1255	1580	1293	1660	$\frac{367}{325} = 112\%$
ARIA 1	2120	2400	2314	2476	$\frac{162}{280} = 57\%$
ARIA 3	2120	2400	2140	2480	$\frac{340}{280} = 121\%$

Table 8 (contd)

Station	Planned times ^a		Actual times ^a		Percent data recovered (actual/planned)
	AOS	LOS	AOS	LOS	
ARIA 2	2385	2670	2414	2850	$\frac{336}{285} = 117\%$
VAN	2445	3165	2525	3253	$\frac{728}{720} = 101\%$

^aAll times in plus seconds from liftoff time of 05:34:00 GMT.

^bARIA 4 was in transit for CTS launch and tracked Helios as an engineering test.

Table 9. Flight event times for Helios-B

Mark	Event	Elapsed time, seconds	
		Nominal	Actual
	SRM ignition	0.0	0.0
0	Liftoff (T/W = 1)	0.2	0.47
1	Separate forward bearing reactors	100.0	100.1
2	Titan stage 1 ignition	112.4	114.9
3	Jettison SRM	123.8	126.8
4	Cutoff stage 1	261.2	265.9
5	Jettison stage 1	261.9	266.6
6	Ignite stage 2	261.9	266.6
7	Jettison shroud	322.0	327.5
8	Cutoff stage 2	468.0	478.1
9	Jettison stage 2	473.8	483.6
10	Centaur MES 1	484.3	495.1
11	Centaur MECO 1	582.1	595.2
12	Centaur MES 2	2277.2	2288.6
13	Centaur MECO 2	2570.3	2775.6
14	TE-M-364-4 spin up	2640.3	2646.1
15	TE-M-364-4 separation	2642.3	2648.1
16	Start Centaur retrothrust	2642.3	2648.1
17	TE-M-364-4 ignition	2684.3	2692.0
18	TE-M-364-4 burnout	2728.1	2735.6
19	Helios-B separation	2800.3	2804.1
20	TE-M-364-4 start YO deploy	2802.3	2806.6

At 0522 GMT, the Telemetry and Command Processor (TCP) at STDN (MIL 71) began processing telemetry data to the MCCC in Pasadena. The planned processing sequence of near-Earth data following launch is shown in Table 10. Refer to Tables 11 through 13 for complete results of the Helios-B telemetry coverage during the near-Earth phase of the launch.

3. Metric Data Support

The metric data flow from all the NETDS radars was approximately that expected, except from Antigua Island and the USNS Vanguard. The Antigua Island radar had intermittent track during the middle of their pass due to an equipment malfunction, which caused the azimuth phase shifter to be 180 degrees out of phase. The USNS Vanguard experienced heavy lobing of the TE-364-4 beacon and locked on a side lobe for a portion of their pass. See Table 14 for the metric data nominal versus actual AOS times.

The RTCS provided JPL orbital elements, standard orbital parameter messages (SOPM), I-matrix, and inter-net predicts as planned. The RTCS provided orbital elements on the parking orbit from the Antigua Island data on the TE-364-4 transfer orbit from USNS Vanguard data, and a spacecraft orbit on DSS 42 two-way metric data.

The Centaur pre-deflection set of orbital elements that were to be generated by the RTCS from USNS Vanguard data was not computed because Vanguard was on a side lobe during the data interval needed for this computation. Likewise, the USNS Vanguard did not have time to switch from the TE-364-4 beacon to the Centaur beacon in order to obtain Centaur post-deflection data after the TE-364-4 data interval was obtained. RTCS, therefore, could not compute orbital elements on the Centaur post-deflection orbital. Nominal predictions for this launch trajectory indicated that it was marginal whether the USNS Vanguard could obtain enough data on the Centaur post-deflection orbit to allow the computation of this solution.

4. Communications Support

The NETDS Communications System successfully supported the Helios-B mission from launch minus 24 hours to launch plus 72 hours. The only communication problem encountered during this period was the loss of voice communication between ARIA control and ARIA, due to poor RF propagation. The possibility of this problem had been foreseen and prior coordination had taken place to have the USNS Vanguard act as backup in order to maintain RF contact with ARIA. This link, via the USNS Vanguard, was used in the late minus count and plus count, thus enabling a relay of all necessary information to and from ARIA.

A summary of the RTCS computations are provided in Table 15.

Table 10. NETDS planned spacecraft real-time
telemetry processing at STDN (MIL 71)*

Telemetry and Command Processor		
Station	Beta string	Alpha string
MIL 71	-	-12600 to 0
MILA	-600 to +450	-
TEL 4	-	0 to +270
GBI	-	-
GTK	-	+270 to +605
BDA	-	-
ANT	+450 to +745	-
ACN	+1280 to +1570	+1280 to +1570
VAN	+2475 to +3120	+2475 to +3120

*All times in seconds from liftoff (05:34:00 GMT)

Table 11. NETDS spacecraft real-time telemetry coverage*

Station	Planned times		Actual Times		Data dropouts at STDN (MIL 71)	Percent data recovery (actual/planned)
	AOS	LOS	AOS	LOS		
MILA	0	450	0	485	4	$\frac{481}{450} = 107\%$
TEL 4	0	450	0	468	20	$\frac{448}{450} = 99.6\%$
GBI	75	495	75	467	15	$\frac{377}{420} = 89.8\%$
GTK	270	605	270	621	28	$\frac{323}{335} = 96.4\%$
BDA	330	620	330	669	22	$\frac{317}{290} = 109\%$
ANT	450	745	450	783	15	$\frac{318}{295} = 108\%$
ACN	1280	1570	1284	1566	0	$\frac{282}{290} = 97.2\%$
VAN	2475	3120	2498	3455	54	$\frac{903}{645} = 140\%$
Average						$\left[\frac{\text{Total actual}}{\text{Total planned}} \right] = 109\%$

*All times in plus seconds from liftoff time of 05:34:00 GMT.

Table 12. NETDS spacecraft real-time telemetry coverage as recognized by the MIL 71 ASU Helios-B launch*

Station	AOS	ASU-recognized number frame sync	LOS
MILA	0	273 to 275	
		397 to 399	485
TEL 4	0	333 to 336	
		338 to 405	468
GBI	75	429 to 435	
		446 to 455	467
GTK	270	289 to 306	
		483 to 487	
		522 to 525	
		544 to 548	621
BDA	330	361 to 378	
		519 to 524	669
ANT	450	470 to 472	
		498 to 500	
		517 to 528	783
ACN	1284	-	1566
VAN	2498	2734 to 2737	
		3311 to 3319	
		3329 to 3337	
		3401 to 3402	
		3411 to 3445	3455

*All times in plus seconds from liftoff (05:34:00 GMT).

Table 13. NETDS spacecraft real-time telemetry decoding - Helios-B launch

Station	Beta DDA		Alpha DDA		Beta DDA	Alpha DDA
	In-lock (L + seconds)	Out-of-lock	In-Lock (L + seconds)	Out-of-lock	Total in-lock (seconds)	Total in-lock (seconds)
MILA	0 352	306 490		-	456	-
TEL 4	-	-	100	306	-	206
GBI	-	-	-	-	-	-
GTK	-	-	415	657	-	242
BDA	-	-	-	-	-	-
ANT	550 631 757	585 711 810	-	-	168	-
ACN	1360	1602	1378 1477	1422 1602	242	169
VAN	2585 2729 2846 3332 3414	2683 2764 3286 3367 3448	2567 2738 2855 3350	2683 2774 3286 3403	643	636
				TOTALS	1509	1253

Percent of data decoded and transmitted to MCCC = $\frac{\text{Actual}}{\text{Planned}} = \frac{1509}{1680} = 90\%$; $\frac{1253}{1540} = 81\%$.

Does not include telemetry frame deletions in the DDAs. All times are plus seconds from liftoff (05:34:00 GMT).

Table 14. NEPN metric data coverage for Helios-B

Station (number)	Link (5765 MHz) vehicle	Acquisition of signal (L + seconds)		Loss of signal	
		Nominal	Actual	Nominal	Actual
Cape (1.16)	Centaur	16	0	370	381
Merritt Island (19.18)	Centaur	14	12	470	502
Patrick AFB (0.14)	Centaur	19	16	472	505
GBI (3.13)	Centaur	86	69	512	517
GTK (7.14)	TE-364-4		Did not support		
BDA (67.18)	TE-364-4	350	360	635	660
ANT (91.14)*	Centaur	443	420	763	768
ASC (12.15)	TE-364-4	1280	1257	1555	1571
ASC (12.16)	TE-364-4	1280	1250	1520	1529
VAN	TE-364-4	2445	2435**	**	3114**
VAN	Centaur	**	3180**	3220	3220

*Antigua track was intermittent during middle of pass, 544 seconds after launch through 600 seconds. This intermittent track was due to an azimuth phase shifter problem.

**Vanguard was to stay on TE-364-4 beacon until 240 seconds of "on-track" data after TE-364-4 burnout was obtained. Vanguard Track was invalid due to locking on a side lobe during the intervals 2470 - 2518, 2534 - 2609, and 2610 through 2876 seconds. After 240 seconds of valid TE-364-4 data was obtained and Vanguard was switched to the Centaur beacon, the Vanguard only had view of the Centaur for 40 seconds before the Centaur went over the horizon.

Table 15. RTCS orbital elements for Helios-B

Parameter*	Parking orbit	TE-364-4 transfer orbit	Spacecraft orbit
Epoch time	593	2728	2728
Radius	6544.1785	6929.2977	6951.8848
Latitude	22.6197	-29.0864	-28.9793
Longitude	300.6311	84.7959	85.2131
Velocity	7.3927	14.2324	14.2184
Path angle	-0.0046	14.0597	14.4896
Azimuth angle	111.9268	80.9134	80.6217
INC	30.301	30.2783	30.2522
ECC	0.000349	2.6673	2.6684
C3	-60.93	99.7485	99.7321

*Epoch time is in seconds from launch. The next six parameters are Earth-fixed sphericals in kilometers, degrees, and kilometers per second. Inclination (INC) is in degrees; eccentricity (ECC) is in degrees and vis viva energy (C3) is in km^2/s^2 .

F. LAUNCH PHASE SUPPORT PROBLEMS AND CORRECTIVE ACTION

During the launch phase of Helios-B, the NETDS experienced tracking problems with the Antigua radar, the Vanguard radar, and the ARIA telemetry support. The following information was consolidated from various agency post-test reports.

1. Antigua Island

The Antigua Island radar had intermittent track from L+420 seconds to L+548 seconds and failed to acquire at L+443 seconds as predicted. However, from L+548 seconds to the end of the station tracking commitment, the Antigua Island radar maintained a solid track. During the tracking interval the site personnel realized that the radar repeatedly drove off track in azimuth and took corrective action by switching the azimuth phase 180 degrees. Subsequent site troubleshooting revealed that a coaxial relay in the phase shifter chassis had failed.

2. NASA Ship Vanguard

The NASA ship Vanguard had trouble acquiring a solid track on the TE-364-4 beacon and lost 3.2 minutes of TE-364 tracking data. Radar operations personnel indicated that the problem was due to poor aspect angles which caused lobing beacon returns. After the aspect angles improved, good tracking data were acquired for computing the TE-364-4 orbit at RTCS.

3. ARIA

ARIA 1 did not acquire quality data on the Centaur telemetry links for the first 195 seconds of the planned coverage interval. All but 7 seconds of this interval, however, was provided by ARIA 3. The ARIA 1 instrumentation configuration was then "frozen" to aid in the evaluation of the problem upon ARIA's return to Wright-Patterson Air Force Base (WPAFB). The ensuing analysis indicated that the signal level at AOS was insufficient to activate the carrier-operated relay, which required a 6-dB signal-to-noise ratio in order to close. Without this closure, autotrack could not be achieved. Failing to achieve autotrack, the Mission Coordinator correctly resorted to use of the pre-test look angle almanac. Quality data were finally acquired at L+2315 seconds (195 seconds later than planned) after launch.

Quality data were not achieved earlier due to errors in the almanac angles. The problem originated in the planning process during the making of necessary interpolations between two trajectories when an error was made in assigning the correct pointing angles with respect to the designated test support position. While the error was relatively small in the AOS region, thus allowing ARIA 1 to detect the signal, the errors increased as a function of time to such an extent that the spacecraft was eventually out of the beamwidth of the ARIA 1 antenna. After ARIA 1 received the correct pointing angle, the pointing angle errors were small enough and the spacecraft signal strength sufficient enough to reacquire and autotrack.

The NETDS had three other problems associated with tracking support. The first and most important of these was communications with all ARIA.

The high-frequency (HF) communications link established between the ARIA Control Center at WPAFB and the ARIA in the Indian Ocean area was extremely poor, especially during the latter part of the countdown and during the launch period. For this reason communications with ARIA were conducted through the secondary communications path via a satellite to the NASA ship Vanguard and relayed via HF from Vanguard to ARIA. Mark events from ARIA were passed in this manner also. There were four major reasons reported for the HF communications being extremely poor to ARIA: (1) propagation due to time of launch, (2) aircraft position resulting in a long HF path, (3) aircraft equipment limitations, and (4) a continual changing HF path requiring multiple frequency changes.

The DOD initiated an investigation in an effort to find a reliable communications link with the ARIA in the Indian Ocean area for future missions.

The second problem was that the Vanguard spacecraft telemetry data were not recorded on magnetic tapes for the first 7.9 minutes after acquisition of the spacecraft telemetry signal because the telemetry operator misinterpreted the information concerning the expected data paths, and, therefore, a video

distribution amplifier was not assigned for spacecraft data. However, the data starting at AOS were sent to STDN (MIL 71) in real-time. The recording error was discovered during the telemetry station's tracking pass, and the last 9.6 minutes of the spacecraft data were recorded.

The last problem was concerned with the AFETR Ascension Island's telemetry tapes not being delivered via ARIA within the requested 52 hours to Patrick Air Force Base (PAFB). This was part of the "quick data return" plan for evaluating Centaur data between Centaur launches. The data arrived some 100 hours after launch via the C-141 Range Liner. The problem appears to have occurred because of an internal DOD communications problem which may have been at least partially caused by the transfer of ARIA from AFETR to WPAFB shortly before the Helios-B launch.

III. DEEP SPACE NETWORK SUPPORT

A. DSN/HELIOS-B SPACECRAFT COMPATIBILITY TESTS

The Helios-B spacecraft followed a very successful three-phase DSN compatibility testing program conducted for the Helios prototype and the Helios-1 spacecraft which utilized a test system that was operationally representative of a standard DSN station and under control of a computer to provide appropriate test conditions in an automatic mode of operations.

1. Telecommunications Compatibility Tests

The Helios-B telecommunications compatibility tests consisted of the following:

- (1) DSN-spacecraft radio frequency tests at both weak and strong signal levels.
- (2) Verification of radio frequency compatibility with the Helios-B spacecraft mated to the launch vehicle.

These tests, which extended over 48 hours from 31 October through 4 November 1975 and for 8 hours on 10 January 1976, provided an assessment of the telecommunications compatibility status between the Helios-B spacecraft and the DSN based on the results obtained between the DSN equipment in the STDN (MIL 71) station.

a. Test Description. The Helios-B spacecraft, located in a "clean room" of Building AO (Fig. 5), was configured for flight operations while the STDN (MIL 71) station was configured to simulate a typical DSN station. An S-band RF air link was utilized between a 1.83-meter antenna at Building AO and a 1.2-meter antenna at the STDN (MIL 71) station. Thus, in this test configuration, the DSN-Helios-B telecommunications testing began on 31 October 1975 and was completed on 4 November 1975. The successful completion of these tests in 48 hours was due in a large measure to the excellent support provided by both the DSN and STDN management and operating personnel. The test results are provided in Table 16.

b. Problems Encountered. There were no major problems during the telecommunications compatibility testing. However, while performing the Telemetry Bit Error Rate (BER) Test, it was necessary to modify the test procedures when large concentrations of low transition densities were observed in the test data, which resulted in erratic signal-to-noise estimations and bit error counts. A check of the spacecraft revealed that all experiments had been turned off by direction of the Project, resulting in no data when these experiments appeared on the spacecraft commutator. Therefore, in order to perform the Telemetry BER Tests in a meaningful manner without the experiments

REPRODUCIBILITY OF THE
ORIGINAL PAGE IS POOR

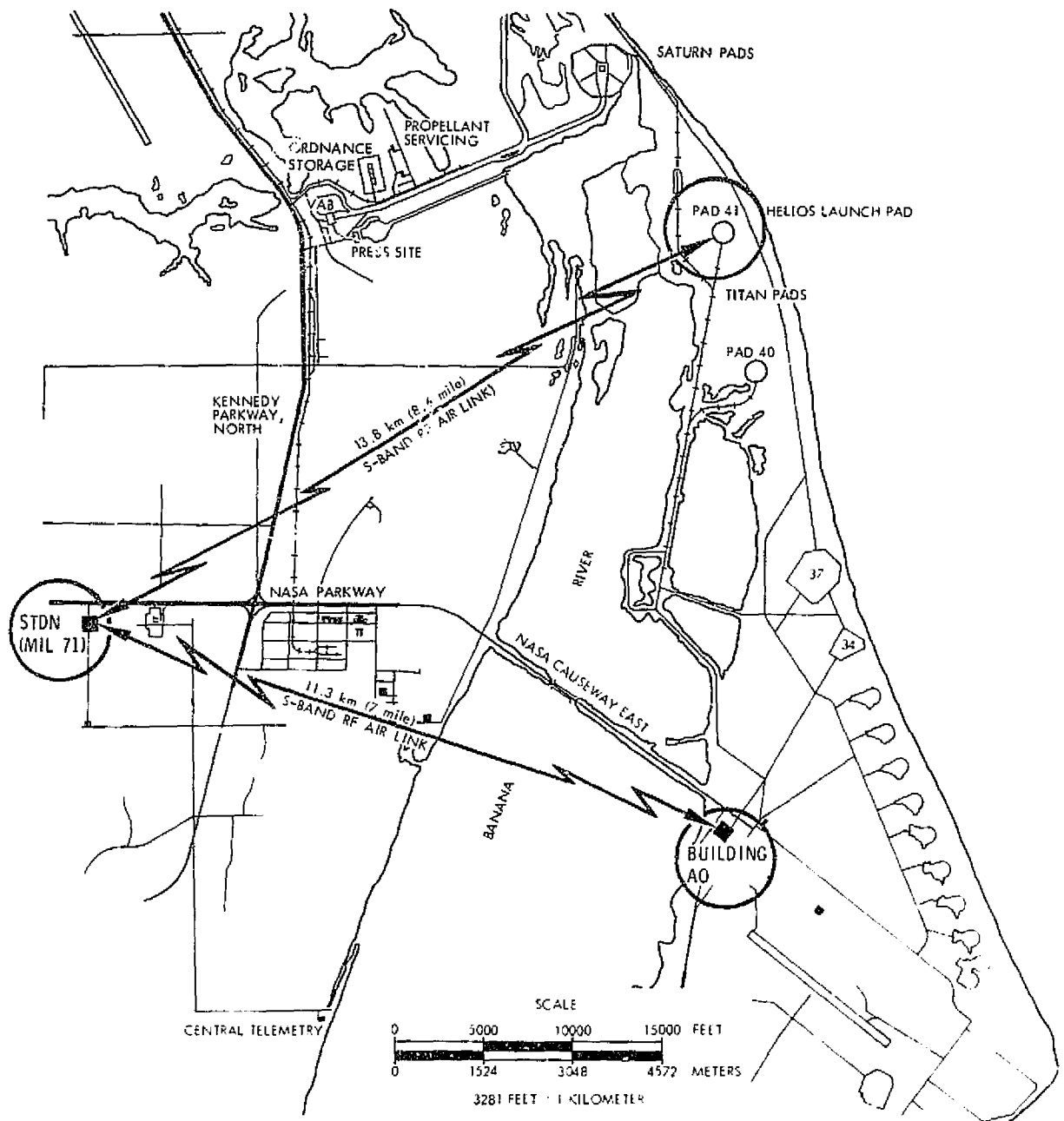

Fig. 6. DSN/Helios-B compatibility test site

Test date, 1975	Test title	Test No.	Deep Space Network									
			RCV	EXC	PRA RNG	CMD	Uplink doppler	Uplink offset	CMA SUBC offset	SDA SUBC offset	CAR SUP	Bit rate
10/10	SC maximum sweep and acquisition rate	I.1	BLK IV, 2295.404288 MHz	BLK IV, 2113.653000 MHz	Off	Off	500 Hz	-80.0 KHz	NA	NA	High	2048
			Same	Same	Off	Off	500 Hz	+80.0 KHz	NA	NA	High	2048
			Same	Same	Off	Off	80 Hz	-9.7 KHz	NA	NA	High	2048
			Same	Same	Off	Off	50 Hz	+9.9 KHz	NA	NA	High	2048
11/8	Downlink spectrum analysis	II.1	BLK IV, -110 dBm, 2295.369920 MHz,	NA	Off	Off	NA	NA	NA	NA	High	2048
		II.2	Same	NA	Off	Off	NA	NA	NA	NA	High	128
		II.3	Same	NA	Off	Off	NA	NA	NA	NA	Low	32
		II.7	2295.359896 MHz -79 dBm	2113.643904 MHz	On (idle seq.)	NA	NA	NA	NA	NA	High	2048
		II.10	Same	Same	On	On	NA	NA	NA	NA	High	128
11/31	Uplink threshold	III.1	BLK IV, -100 dBm, 2295.369932 MHz	BLK IV, 2113.653000 MHz	Off	Off	NA	NA	NA	NA	High	128
		III.2	Same	Same	On	Off	NA	NA	NA	NA	High	128
		III.3	Same	Same	Off	Off	NA	NA	NA	NA	High	128
10/31	Carrier residual phase jitter	IV.1	BLK IV, -104 dBm, 2295.369728 MHz	BLK IV, 2113.653000 MHz	Off	Off	NA	NA	NA	NA	High	2048
		IV.2	BLK IV, -100 dBm, 2295.365024 MHz	BLK IV, 2113.653000 MHz	Off	Off	NA	NA	NA	NA	High	2048
		IV.3	BLK IV, -104 dBm, 2295.369728 MHz	BLK IV, 2113.653000 MHz	Off	Off	NA	NA	NA	NA	High	2048
					Off	Off	NA	NA	NA	NA	High	2048

Table 16. DSN/Helios-B telecommunications test summary

Spacecraft								Test data			
EXC	RCV	PWR	ANT	TWT	RNG	SC DM	SC FM	Performance	Criteria	Test time	Test Comments
1	1 -102 dBm	HP	MGA	2	Off	0	4	Acquired at -100 dBm; tracked to +65 kHz	Acquire at -100 dBm; track to +32.5 kHz	2 hr 32 min	Acquired UL at best lock (VCX01)
1	1 -102 dBm	HP	MGA	2	Off	0	4	Acquired at -100 dBm; tracked to -32.5 kHz	Acquire at -100 dBm; track to -32.5 kHz	2 hr 32 min	Acquired UL at best lock (VCX01)
1	1 -102 dBm	HP	MGA	2	Off	0	4	Acquired at -141 dBm; tracked to +32.5 kHz	Acquire at -141 dBm; track to +32.5 kHz	2 hr 32 min	Rcvr 2 OK; Rcvr 1 dropped +7 kHz at -141 ±1; both rcvr's OK at -139 ±1
1	1 -102 dBm	HP	MGA	2	Off	0	4	Acquired at -141 dBm; tracked to -32.5 kHz	Acquire at -141 dBm; track to -32.5 kHz	2 hr 32 min	Acquired UL at best lock (VCX01)
1	1	HP	MGA	1	Off	0	4	No spurs observed	No spurious signal within 30 dB of the carrier	9 min	Subcarrier osc No. 2 noncoherent mode
1	1	LP	LGA	NA	Off	0	4	No spurs observed	No spurious signal within 30 dB of the carrier	41 min	Subcarrier osc No. 1 noncoherent mode
1	1	LP	LGA	NA	Off	0	4	No spurs observed	No spurious signal within 30 dB of the carrier	10 min	Subcarrier osc No. 1 noncoherent mode
1	1 -103.5 dBm	LP	LGA	1	Off	0	4	No spurs observed	No spurious signal within 30 dB of the carrier	22 min	VCX01, coherent (Goldstone first acq.) mode
1	1 -103.5 dBm	HP	MGA	1	On	0	4	No spurs observed	No spurious signal within 30 dB of the carrier	15 min	VCX01, coherent
1	1	HP	MGA	2	Off	0	4	-154.5 dBm	-155.0 ±1.0 dBm	50 min	Threshold value is average of 3 measurements. Link variations of ±1.5 dB were noted in Subtest 2
1	1	HP	MGA	2	On	0	4	-153.5 dBm	-155.0 ±1.0 dBm	31 min	
1	2	HP	LGA	2	Off	0	4	-154.83 dBm	-155.0 ±1.0 dBm	48 min	
1	1 -105 dBm	HP	MGA	1	Off	0	4	4.9° deg rms	5.7 deg rms	16 min	
2	1 -102 dBm	HP	MGA	2	Off	0	4	3.275 deg rms	5.7 deg rms	30 min	RF link variation
1	1 -104 dBm	HP	MGA	2	Off	0	4	1.77 deg rms	2.86 deg rms	38 min	10 dB p-p
1	1 -104 dBm	HP	MGA	2	Off	0	4	14.08 deg rms	22.9 deg rms		F-2 SC exhibited greater residual phase jitter than F-1 SC because of aux. osc. crystals. Inferior performance not unexpected but still met criteria.

Test date, 1975	Test title	Test No.	Deep Space Network									
			RCV	EXC	PRA RNG	CMD	Uplink doppler	Uplink offset	CMA SUBC offset	SDA SUBC offset	CAR SUP	Bit rate
10/81		IV.4	BLK IV, -104 dBm, 2295.369728 MHz	BLK IV, 2113.653000 MHz	Off	Off	NA	NA	NA	NA	High	2048
					Off	Off	NA	NA	NA	NA	High	2048
11/4	Bit error rate	VIII.1	BLK IV, -146 dBm, 2295.369774 MHz	BLK IV, 2113.653000 MHz	Off	Off	NA	NA	NA	NA	Low	8 (coded)
		VIII.2	BLK IV, -140 dBm	BLK IV, 2113.653000 MHz	Off	Off	NA	NA	NA	NA	Low	82 (coded)
11/4	Telemetry erasure rate	IX.1	BLK IV, -143.5 dBm, 2295.369800 MHz	BLK IV, 2113.653024 MHz	Off	On	NA	NA	NA	NA	High	128
		IX.2	BLK IV, -138 dBm, 2295.369800 MHz	2113.653024 MHz	On	On	NA	NA	NA	NA	High	512
		IX.3	BLK IV, -134.5 dBm, 2295.369800 MHz	BLK IV, 2113.653024 MHz	Off	On	NA	NA	NA	NA	High	1024
10/81	Subcarrier frequency and phase jitter	X.1	BLK IV, -104 dBm, 2295.369728 MHz	BLK IV, 2113.653000 MHz	Off	Off	NA	NA	NA	NA	High	128
		X.2	BLK IV, -104 dBm, 2295.369728 MHz	BLK IV, 2113.653000 MHz	Off	Off	NA	NA	NA	NA	High	128
		X.3	Blk IV, -104 dBm, 2295.369728 MHz	BLK IV, 2113.653000 MHz	Off	Off	NA	NA	NA	NA	High	128
10/81	SC command	XI.1	BLK IV, -100 dBm, 2295.369774 MHz	BLK IV, 2113.653000 MHz	Off	On	NA	NA	NA	NA	High	128
		XI.2	Same	Same	On	On	NA	NA	NA	NA	High	512
		XI.3	Same	Same	Off	On	NA	NA	NA	NA	High	1024

Block III Receiver I, Exciter 1 used for all tests.

REPRODUCIBILITY OF THE
ORIGINAL PAGE IS POOR

Table 16 (contd)

Spacecraft								Test data		Test time	Comments
EXC	RCV	PWR	ANT	TWT	RNG	SC DM	SC FM	Performance	Criteria		
1	2 -104 dBm	HP	LGA	2	Off	0	4	2.05 deg rms	2.86 deg rms	25 min	
1	2, -104 dBm	HP	LGA	2	Off	0	4	14.57 deg rms	22.9 deg rms		
1	1 -135 dBm	HP	MGA	2	Off	0	4	1.7×10^{-4}	10^{-4}	2 hr 27 min	Coded mode
1	1 -130 dBm	HP	MGA	2	Off	0	4	1.3×10^{-5}	10^{-4}	3 hr 4 min	Coded mode
1	1 -128.1 dBm	HP	MGA	2	Off	0	4	TCP $\alpha = 0$ TCP $\beta = 0$	10^{-3}	628 min	
1	1 -126 dBm	HP	MGA	2	On	0	4	TCP $\alpha = 0$ TCP $\beta = 0$	10^{-3}	115 min	
1	1 -133 dBm	HP	HGA	2	Off	0	4	TCP $\alpha = 1.99 \times 10^{-4}$ TCP $\beta = 7.98 \times 10^{-4}$	10^{-3}	208 min	
1	-105 dBm	LP	LGA	NA	Off	0	4	0.505 deg rms 32,768 Hz	1.15 deg rms 32,768 Hz	38 min	SC DHE osc. No. 1 Chain 1
2	NA -105 dBm	LP	LGA	NA	Off	0	4	0.505 deg rms 32,768 Hz	1.15 deg rms 32,768 Hz	12 min	SC DHE osc. No. 1 Chain 2
2	NA -105 dBm	LP	LGA	NA	Off	0	4	0.51 deg rms 32,768 Hz	1.15 deg rms 32,768 Hz	10 min	SC DHE osc. No. 2 Chain 2
1	1 -144 dBm	HP	MGA	2	Off	0	4	54 commands accepted and processed	All commands accepted by SC	37 min	VCX01, coherent, command SC at 512 Hz
1	1 -137 dBm	HP	MGA		On	0	4	54 commands accepted and processed	All commands accepted by SC	25 min	
1	2 -144 dBm	HP	HGA	2	Off	0	4	54 commands accepted and processed	All commands (continuous) accepted and processed	38 min	VCX02, coherent, command SC at 448 Hz

being turned on, it was decided to switch from the uncoded mode to the coded mode, thereby increasing the data transition density.³ Thus, the 8-bps test was performed at 16 sps. This required that the downlink signal levels be adjusted to correct for the different data rate, and the tests were successfully completed.

2. RF and Data Verification Tests

The RF and Data Verification Tests were conducted on 10 January 1976 to verify the continued telecommunications compatibility status between the DSN and the Helios-B spacecraft after encapsulation and mating to the launch vehicle.

a. Test Description. The launch vehicle with the encapsulated Helios-B spacecraft was located on Launch Pad 41. Again, an S-band RF air link was utilized to establish the spacecraft-ground station interface with the STDN (MIL 71) station (Fig. 6). This RF air link consisted of a 1.2-meter antenna at the STDN (MIL 71) station and a 1.2-meter antenna on the Launch Service Tower, which was connected to a test point on the shroud encapsulating the spacecraft.

Thus, in this test configuration, the RF and Data Verification Tests were successfully conducted in 8 hours. The test results are provided in Table 17.

b. Problems Encountered. There were no major problems during the testing. However, initial efforts to perform spacecraft maximum sweep and acquisition as well as uplink threshold tests were seriously hampered by 5.0-dB fluctuations of the RF link. An investigation revealed these fluctuations to be due to the heavy traffic and other activities being conducted on the launch tower. It was not until after all other activities had ceased at the end of the day that these two tests were successfully performed.

B. PRELAUNCH TEST AND TRAINING

Essentially the test and training plan for Helios-B was the same as outlined for Helios-A, except on an abbreviated scale. The test and training effort for the DSN started with the distribution of the Helios-B on-site Operator Training Plan and Sequence of Events to all Helios supporting stations. These training exercises were designed to prepare the DSS operators on the use of hardware, software, and procedures required for Helios-B configuration and support.

³See Volume I of this Technical Memorandum, Section IV-B-4, p. 65, regarding Project rationale for launching Helios-1 in the coded mode.

1. Operations Verification Tests

With the daily tracking of the Helios-1 spacecraft, most Helios operations procedures were practiced on each track. The DSN Operations Verification Tests (OVTs) were designed to utilize the Helios-1 spacecraft telemetry and command systems to practice those operational requirements infrequently used in day-to-day operations, such as manual mode commanding and analog tape playback. Three tests were conducted with two stations at Goldstone, California (DSSs 11 and 12) and one station in Australia (DSS 44). Manual mode commanding and analog tape playback were practiced as well as normal Helios-1 spacecraft support activities. All test objectives were met during each test.

The 26-meter stations completed their OVTs for Helios-B in early September with the last three tests being performed with DSSs 42, 61, and 62. All three tests were successfully completed, reinforcing the Helios-B test and training philosophy of minimizing redundant testing and concentrating on Helios-B unique operational requirements.

a. Initial Acquisition. Special DSN tests, concerning critical portions of the mission (initial acquisition and Step II maneuver), were begun in mid-October, and continued through mid-November. Approximately six each of these tests were planned, four in October with the remaining in November. The first three initial acquisition tests were conducted with DSS 42/44. All were completed satisfactorily with only minor discrepancies. The two Viking spacecraft launches in August and September 1975 added a measure of confidence and experience to the operational crews.

Network testing for Helios-B initial acquisition with Australian Deep Space Stations 42 and 44 was completed by mid-November. Each station's operational crews participated in at least one OVT--some in as many as three. Test scheduling conflicts with operational commitments, plus some doubt about the exact Helios-B launch date, prevented conducting the desired number of initial acquisition OVTs with the crew selected to support launch activities. However, several Mission Operations System (MOS) tests did exercise these procedures with the station launch support crew.

In January 1976, final initial acquisition tests were completed at DSSs 42 and 44 in Australia. Nominal spacecraft and silent spacecraft acquisition cases were conducted with excellent results from all operational facilities and personnel.

b. Step II Maneuver. Step II maneuver OVTs began with the first test at Goldstone DSS 12 on 7 November. Six successful tests were conducted, four with DSS 12 and two with DSS 11 in December 1975.

The plan for DSS support for the Helios-B Step II maneuver differed slightly from that of Helios-1, the difference being in the antenna polarization configuration prior to track. DSS 12 was configured for linear horizontal polarization, while DSS 11 was configured linear vertical (the reverse of their Helios-1 configuration). As the spacecraft's aspect angle changed by attitude commands, the downlink signal polarization changed from linear horizontal to linear vertical. Thus the signal level received at DSS 12 decreased while that at DSS 11 increased. When the signal strength at DSS 11 surpassed that at DSS 12, the Project transferred the uplink signal to

Test date, 1976	Test title	Test No.	Deep Space Network									
			RCV	EXC	PRA RNG	CMD	Uplink doppler	Uplink offset	CMA SUBC offset	SDA SUBC offset	CAR SUP	Bit rate
1/10	SC maximum sweep and acquisition rate	I.1	-97 dBm	2113.621152 MHz to 2113.685148 MHz	Off	Off	500 Hz	-30 kHz to +32.5 kHz	NA	NA	High	2048
			-97 dBm	2113.682976 MHz to 2113.618580 MHz	Off	Off	500 Hz	+30 kHz to -32.9 kHz	NA	NA	High	2048
1/10	Uplink threshold	III.1	-115 dBm, 2295.368688 MHz	2113.652000 MHz	Off	Off	NA	NA	NA	NA	High	2048
		III.3	-115 dBm, 2295.368688 MHz	2113.652000 MHz	Off	Off	NA	NA	NA	NA	High	2048
1/10	Downlink threshold	V.1	2295.369056 MHz	2113.652000 MHz	Off	Off	NA	NA	NA	NA	High	128
1/10	Ranging system acquisition time	VII.1	-112 dBm, 2295.368688 MHz	2113.652000 MHz	On	Off	NA	NA	NA	NA	High	128
1/10	Telemetry performance	IX.1	2295.368688 MHz	2113.652000 MHz	Off	On	NA	NA	NA	NA	High	128
		IX.3	-114 dBm, 2295.368688 MHz	2113.652000 MHz	Off	On	NA	NA	NA	NA	High	1024
1/10	Spacecraft command	XI.1	-115 dBm, 2295.368688 MHz	2113.652000 MHz	Off	On	NA	NA	NA	NA	High	2048
		XI.3	-115 dBm, 2295.368688 MHz	2113.652000 MHz	Off	On	NA	NA	NA	NA	High	2048

Block III Receiver I, Exciter 1 used for all tests.

REPRODUCIBILITY OF THIS ORIGINAL PAGE IS POOR

Table 17. DSN/Helios-B Launch Complex 41 telecommunications test summary

Spacecraft								Test data		Test time	Test Comments
EXC	RCV	PWR	ANT	TWT	RNG	SC DM	SC FM	Performance	Criteria		
1	1 and 2 -110 dBm	HP	LGA	2	Off	0	4	Acquired and tracked	Acquire at best lock, track to +32.5 kHz	15 min	2113.652000 kHz, best lock frequency SC receiver 1/2
1	1 and 2 -110 dBm	HP	LGA	2	Off	0	4	Acquired and tracked	Acquire at best lock, track to -32.5 kHz		
1	1	HP	LGA	2	Off	0	4	-157.2 dBm	To be measured	2 hr 4 min	Average of 3 runs, link variance 1.5 dB P-P
1	2	HP	LGA	2	Off	0	4	-157.0 dBm	To be measured		Average of 2 runs, link variance 1.5 dB P-P
1	1	HP	LGA	1	Off	0	4	-157.5 dBm	-159.0 ±3 dBm	20 min	Average of 3 runs, link variance 8.0 dB P-P
1	1 -116.5 dBm	HP	LGA	1	On	0	4	1-minute acquisition 98827 RU	TBD	8 min	15 components, discrete 1 minute integration time
1	1 -113 dBm	HP	LGA	1	Off	0	4	Decommutated data satisfactory	30 min of decommutated data	33 min	SDA freq. 131072.0 Hz
1	2 -113 dBm	HP	LGA	1	Off	0	4	Decommutated data satisfactory	30 min of decommutated data	33 min	SDA freq. 131072.0 Hz
1	1 -108 dBm	HP	LGA	2	Off	0	4	All good commands (210 commands)	All commands successfully received by SC	39 min	Commands 501-506, 512-Hz subcarrier
1	2 -108 dBm	HP	LGA	2	Off	0	4	All good commands (210 commands)	All commands successfully received by SC	42 min	Commands 501-506, 448-Hz subcarrier

DSS 11 for the remainder of the track. DSS 12 reconfigured to linear vertical polarization for the remainder of the pass.

c. Helios-B Performance Demonstration Tests. The Helios-B Performance Demonstration Tests (PDTs) were originally scheduled to be conducted in October 1975. However, in the interest of reducing the number of testing schedule conflicts between Helios-B and various other flight projects, and because of the successful results of other Helios testing, the Helios-B PDTs were cancelled.

d. Helios-B Spacecraft End-to-End Test. The Helios-B End-to-End Test was conducted with the Helios-B spacecraft at Cape Canaveral, and required the combined cooperation of the STDN (MIL 71), AFETR, NASCOM, DSN, and GSOC in order to verify the operational command and telemetry data link planned for the Helios-B launch. Because the launch and Mission Phase I operations were to be controlled from GSOC in Germany and not at JPL, the DSN took a passive role during the testing of this new launch configuration.

Testing was conducted from 18 through 20 October 1975 and required two 8-hour shifts per day, for a total of 48 hours.

As in most tests minor problems were encountered but none of a major nature that would affect the operational readiness of the DSN or the GSOC to support the Helios-B launch.

e. DSN Configuration Verification Tests. A DSN Configuration Verification Test (CVT) was performed with each DSN 26-meter station scheduled to support Helios-B in order to verify the Network launch configuration. Each CVT was designed to simulate those station activities expected during the first day's coverage of Helios-B. The CVTs were scheduled to take place just prior to the launch so that each station could maintain its verified Helios-B launch configuration after the completion of the test. Therefore, upon successfully completing its CVT, each DSN station configuration was frozen (no changes permitted) until after successful acquisition of downlink signal and completion of the Helios Step II maneuver.

Initial acquisition was simulated at DSSs 42 and 44 in Australia. Nominal spacecraft and silent spacecraft acquisition cases were conducted with excellent results from all operational facilities and personnel.

Step II maneuver procedures were practiced with DSSs 11 and 12 at Goldstone. This maneuver was planned during the first pass. All test objectives were met, and the test sequence was completed, free of problems.

Cruise operational procedures were emphasized during the CVT at DSS 61 in Spain. Some contingency procedures, such as manual commanding and an analog tape playback, were included in the CVT. All facets of the test went smoothly, and, upon completion, the station was placed under modified configuration control.

The CVTs brought DSN Helios-B testing to a close.

C. MISSION PHASE I SUPPORT

1. Launch Operations

Launch preparations for a 15 January 1976 liftoff of Helios-B were initiated with the Deep Space Station prelaunch countdowns. Prime DSN stations participating in the Helios-B first pass countdowns were the Spacecraft Compatibility-Monitor Station, Cape Canaveral (STDN (MIL 71)), DSSs 42 and 44 in Australia, DSS 61 in Spain, and DSSs 11 and 12 at Goldstone.

The Helios-B spacecraft was successfully launched on schedule at 05:34:00.36 GMT on 15 January 1976. All Titan-Centaur-Delta launch vehicle stages performed nominally. Data were received from the various downrange, Near-Earth Phase Network (NEPN) stations, and the spacecraft was injected into the desired orbit around the Sun with a preliminary perihelion distance of 0.29 astronomical units (AU) and an orbit period of 185 days. Immediately after solar orbit injection, the Helios-B mission was redesignated Helios-2.

Primary control of Helios-2 post-launch and mission activities resided at the German Space and Operations Center (GSOC). The spacecraft team was located at GSOC with a backup team at JPL. Because the launch phase and attitude maneuver computer programs, generated for Helios-1, were available at JPL, the spacecraft attitude and navigation teams were located at JPL for the first weeks of the Helios-2 mission. The interface with STDN (MIL 71) for launch and the downrange stations was handled by the Chief of Mission Operations Support (CMOS). This function was previously handled by the DSN Operations Control Team (OCT).

The German Space and Operations Center systems performed very well during the entire launch phase as did the Deep Space Network and all other systems at JPL.

2. DSN Initial Acquisition

DSN initial acquisition by DSSs 42 and 44 in Canberra, Australia, occurred at 0624 GMT on 15 January 1976. DSS 42 provided the prime source of data with DSS 44 in the role of a redundant backup.

At initial acquisition, the Helios-2 spacecraft was transmitting via its low-gain antenna system. This antenna system consists of a linearly polarized dipole element at the top of the spacecraft and a circularly polarized horn antenna at the bottom.⁴ The spacecraft radiation pattern boundary between the top dipole antenna and the bottom circular horn antenna element of this omni-antenna system creates an interference region.⁵ Approximately 5 minutes after initial acquisition, the Helios-2 spacecraft aspect angle was such

⁴See Fig. 1, page 10 in Volume I of this Technical Memorandum.

⁵See Fig. 3, page 14 in Volume I of this Technical Memorandum.

that this interference region was experienced for about 3 minutes. During the Helios-1 launch phase, this region was predicted to be much longer (approximately 8 minutes) and caused concern as to the quality of telemetry data while in this region. However, during the actual flight of Helios-1, the signal degradation caused by this interference region proved to be much less than feared. During the Helios-2 flight, the downlink signal degradation (8 to 9 dB) was hardly noticeable at DSS 42.

DSS 42 instructions for the uplink acquisition sweep were as follows:

Ramp start time	=	06:31:00 GMT
Starting frequency	=	22.017880 MHz (VCO)
Frequency rate	=	3 Hz/s (VCO)
Ramp end time	=	06:32:20 GMT
Ending frequency	=	22.018120 MHz (VCO)
Sweep duration	=	80 seconds

The instructed sweep and the sweep actually executed by DSS 42 can be seen in Fig. 7. The station tuned manually at a remarkably constant rate of about 2.5 Hz/s or about 85% of the instructed rate. Due to a late start (about 10 seconds late) and the slow tuning rate, the final tracking synthesizer frequency (TSF) was achieved some 25 seconds late. These minor departures from the nominal sweep parameters had no effect on the success of the acquisition.

Uplink tuning began on schedule while, coincidentally, antenna pointing was being manually adjusted. Despite the fact that the pointing adjustment involved some rather large antenna excursions (up to 0.8 degree from nominal), pointing errors had no impact on the uplink acquisition since uplink transmission was through the DSN broadbeam S-Band Acquisition Antenna (SAA). Telemetry data confirmed that a nominal uplink acquisition had occurred when the spacecraft's receiver automatic gain control reading changed precipitously in response to DSS 42's signal.

A brief period (about 12 minutes) of two-way noncoherent tracking following the uplink acquisition proceeded routinely up to the time of the command that caused the spacecraft to shift its downlink signal frequency to become coherent with the uplink. In preparation for this command and the resulting receiver-out-of-lock condition, DSS 42 returned antenna drive to computer mode (drive tape) with offsets to compensate for the angle biases observed during the autotrack period.

After dropping lock due to the coherent command, receivers were in lock again 20 seconds later, but at a signal level some 30 dB below the predicted value. The low signal level evoked some discussion among Network Operations Control Team (NOCT) and advisory personnel and between DSS 42 and the tracking controller at JPL as to whether a sideband (i.e., a spurious signal) acquisition or an antenna sidelobe acquisition had occurred. Meanwhile tracking data from DSS 42 were erroneously flagged as one-way for some 3-1/2 minutes. Finally, after locking up and re-tuning receivers twice and performing manual adjustments

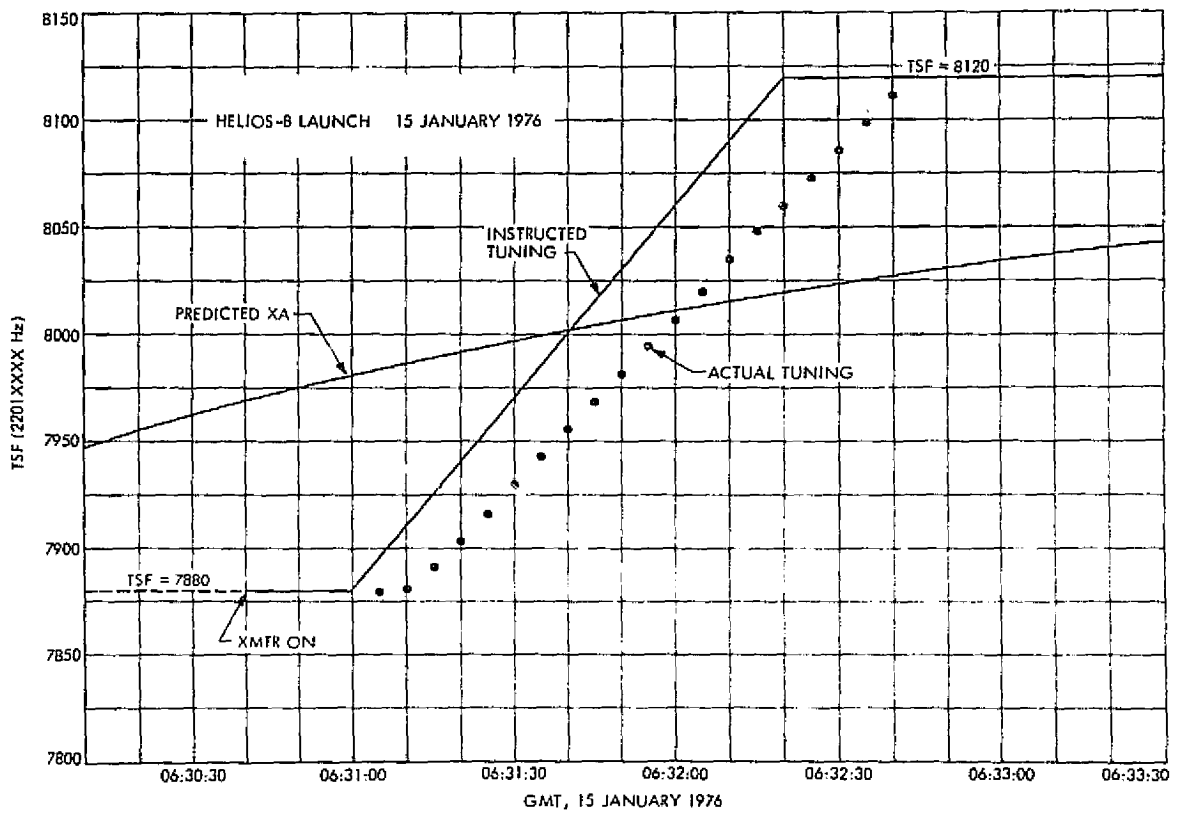

Fig. 7. Comparison of actual tuning to instructed tuning at DSS 42

to antenna pointing angles, DSS 42 obtained solid receiver lock on the spacecraft's carrier signal, at normal levels. The period from first receiver-out-of-lock condition (due to switch in downlink frequency) until receiver lockup on the coherent downlink carrier was about 6 minutes 15 seconds. Quantitative details of the reacquisition may be seen in the graphs of hour angle residuals and doppler residuals in Figs. 8 and 9, respectively.

The remainder of the DSS 42 pass, for most tracking purposes a routine cruise-phase operation, proceeded smoothly and without incident.

DSS 44, the backup acquisition station, acquired the Helios-2 downlink signal at approximately 06:24:15 GMT, 20 seconds after the predicted spacecraft rise time. The S-band downlink was reestablished by DSS 44 approximately 17 seconds after losing receiver lock caused by the spacecraft being commanded by DSS 42 from a noncoherent mode to a coherent mode. Twenty seconds later, DSS 44 reported in three-way mode of operation and autotracking.

One anomaly during the pass was quickly noticed and corrected by alert DSS 44 personnel. Moments after spacecraft rise and a flawless acquisition of the downlink, the station reported a problem with the X-angle antenna drive. The erratic behavior of the drive can be clearly seen in the graph of the pseudo-residual for the X-angle shown in Fig. 10. The dramatic effect of the station's corrective action -- manual peaking of the signal and subsequent switchover to autotrack -- is equally clear in the plot of signal level from the station's S-Band Cassegrain Monopulse (SCM) antenna feed cone.

It is worthy of note that the forced switch to autotrack occurred before the interference zone, and, hence, DSS 44 tracked throughout the zone in autotrack mode with no harmful results.

3. Step I Maneuver

The Step I maneuver orients the Helios spacecraft such that its solar panels are evenly illuminated by the Sun, with the spacecraft's spin axis lying essentially in the plane of the ecliptic (i.e., the plane of its injection). This maneuver was required for both electrical power and thermal control and was executed completely as planned, and without incident.

4. Near-Earth Experiments Turn-On

Following the Step I maneuver, turn-on of the near-Earth experiments was executed. During this instrument turn-on and science experiment antennae deployment, the spacecraft telemetry indicated that the cover for Experiment 10 (Micro-meteoroid Detector and Analyzer) had failed to jettison. However, after careful analysis of other spacecraft instruments, and thermal and attitude parameters, the Project concluded that there was a high probability that the cover did indeed jettison and that the telemetry indicator was faulty. Experiment 10 seemed to be functioning normally for this portion of the mission, and the data was carefully scrutinized by the Helios spacecraft team as the mission progressed. Spacecraft experiment calibration and memory readouts continued through the first Madrid (DSS 61) pass.

REPRODUCIBILITY OF THE
ORIGINAL PAGE IS POOR

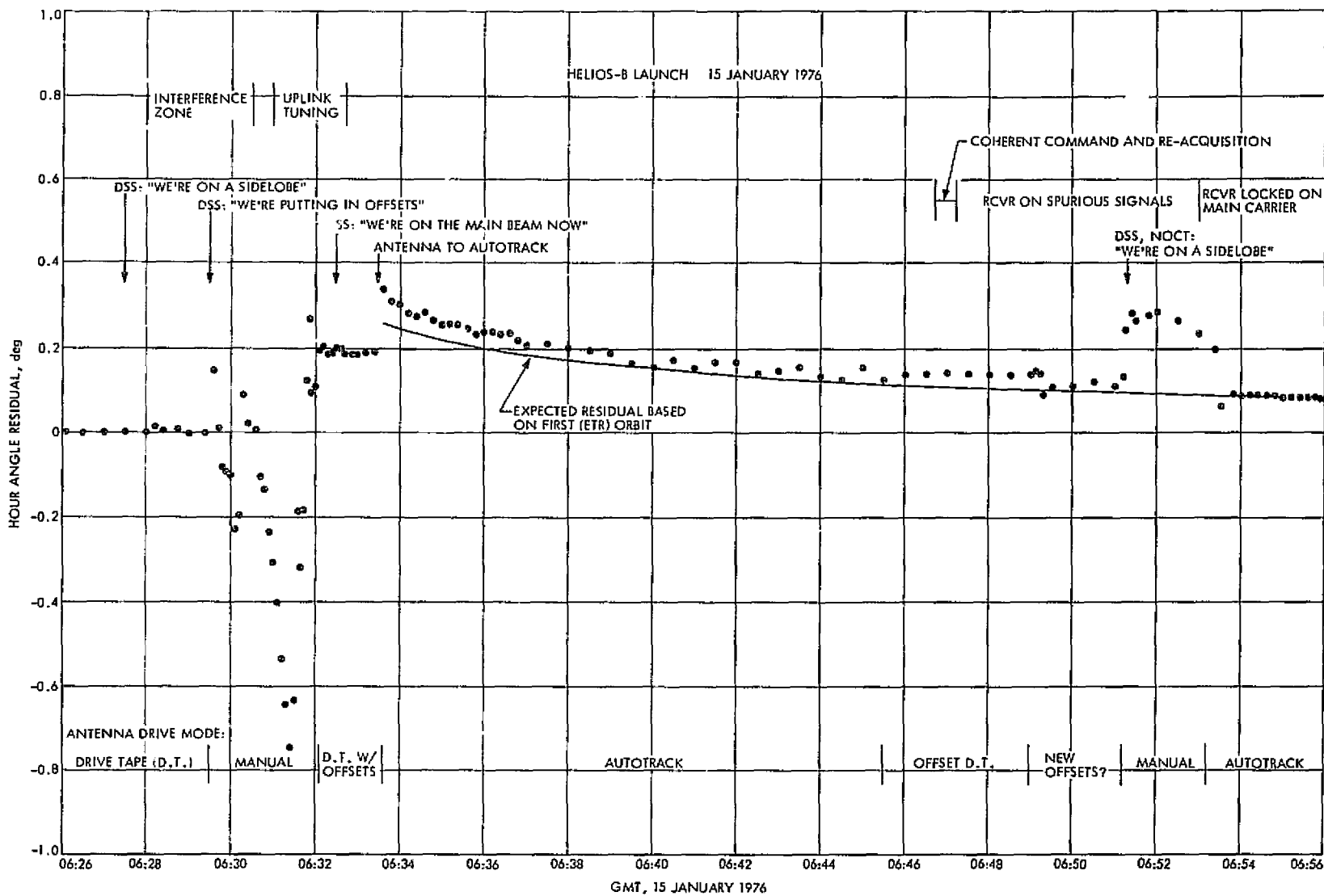

Fig. 8. DSS 42 hour angle residual

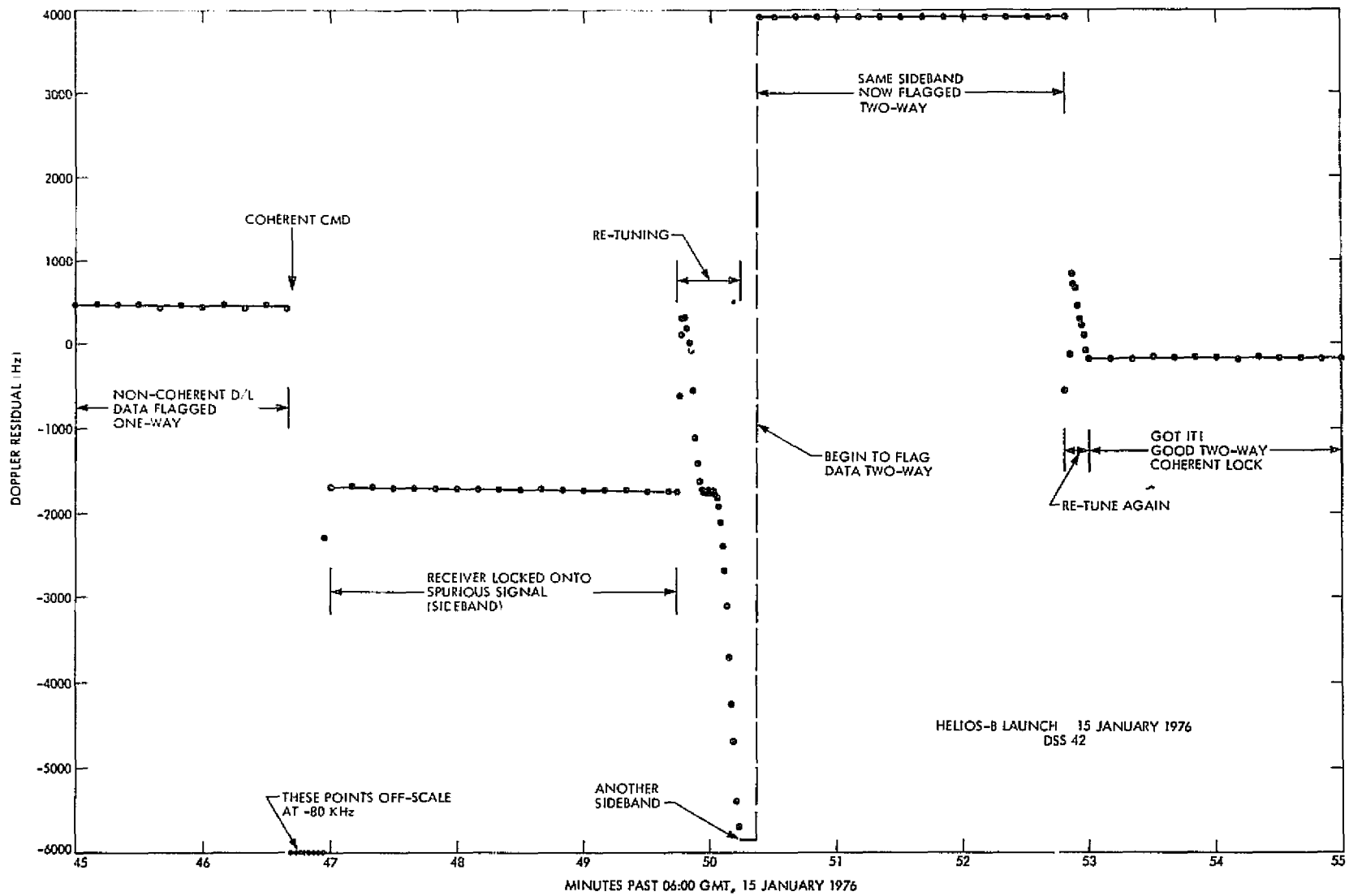

Fig. 9. Noncoherent/coherent downlink reacquisition

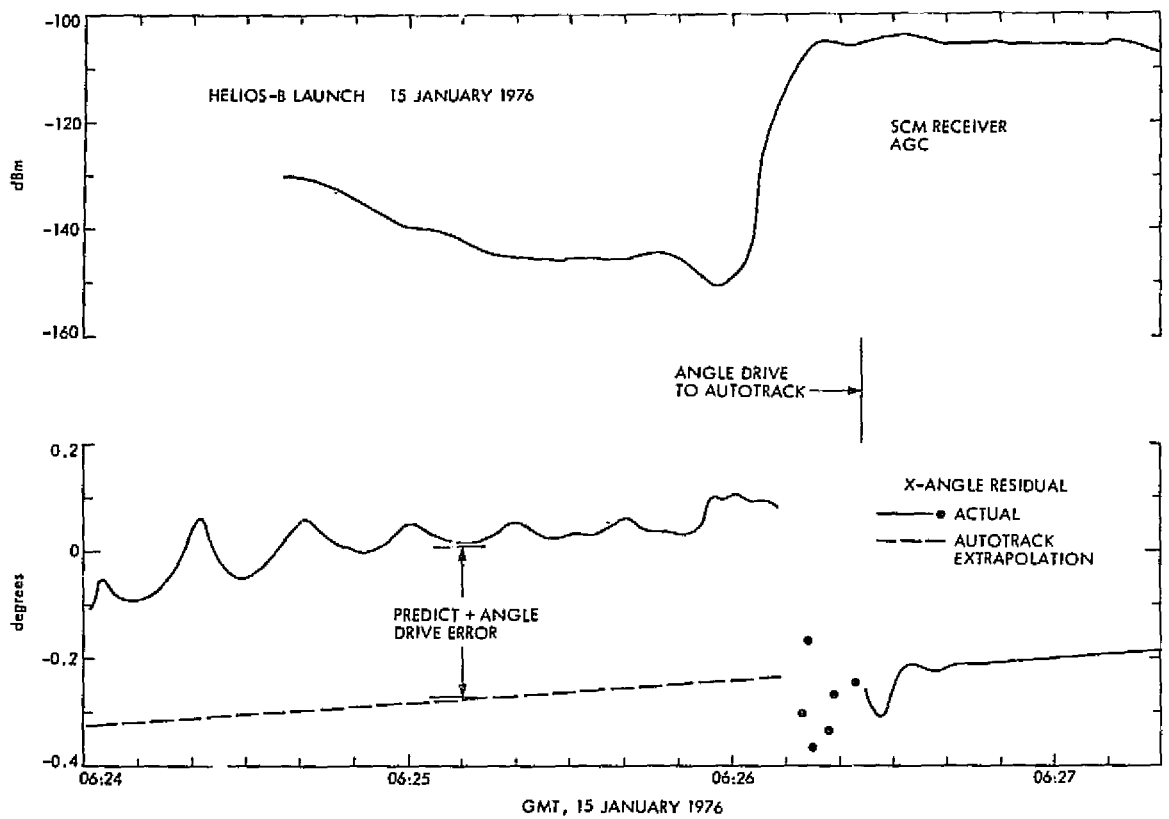

Fig. 10. DSS 44 angle drive failure and effect on signal level

5. Step II Maneuver

With the Helios-2 spacecraft's first rise over Goldstone, preparations were started for the Step II maneuver. The spacecraft telemetry format was switched from science to engineering data so that more spacecraft parameters could be monitored during the maneuver.

Commands were sent to the Helios-2 spacecraft to calibrate the attitude control gas jets in preparation for the Step II maneuver. This calibration allowed more precise control over the spacecraft during the maneuver sequence.

Commands were initiated to pitch the spacecraft such that the antenna mast moved toward the south pole of the ecliptic. This was a deliberate change from Helios-1 in order to provide zodiacal light experiment coverage in the northern ecliptic hemisphere.⁶ Helios-1 will continue to provide zodiacal light sensing in the southern ecliptic hemisphere during its remaining lifetime.

During the Step II maneuver, the spacecraft's attitude was determined by monitoring the amount of spin modulation on the doppler frequency. As the spacecraft's attitude changes, the spin modulation increases until the low-gain antenna interference region is encountered. To traverse this interference region, two Deep Space Stations (DSSs 11 and 12) were configured to receive linear signals polarized 90 degrees apart. DSS 12 was configured for linear horizontal antenna polarization, while DSS 11 was configured for linear vertical antenna polarization. Telemetry from both stations was supplied to the Mission Control and Computing Center (MCCC) at JPL via high-speed data lines. Telemetry from DSS 12 was selected from the first half of the Step II maneuver, and as the signal level decreased from DSS 12 an increase in DSS 11's signal level followed. When the signal at DSS 11 surpassed that of DSS 12, DSS 11's telemetry was processed. The degradation of the signal was not severe, so the interference region was traversed without difficulty. Midway through the Step II maneuver, the spacecraft's transmitter was switched to the medium-gain antenna supplying a 6-dB increase in signal level.

During this period, spacecraft temperatures were running low, reaching so-called "soft limits" at various points. This was due to a Project decision to remain in the traveling-wave tube (TWT) medium-power mode during this period. To avoid any further decrease of temperatures (caused by gas supply usage), the Project decided to delay the spin-up maneuver.

At the end of the Step II maneuver, the spacecraft had been positioned with the antenna mast aligned toward the south pole of the ecliptic. The medium-gain antenna (MGA) pattern was close to its peak value, and only minor corrections were required. Several small trim maneuvers were completed during Goldstone passes 3 and 4 in order to bring the zodiacal light experiment, E-9, into its required attitude to acquire reference stars. Ranging was

REPRODUCIBILITY OF THE
ORIGINAL PAGE IS POOR

⁶The zodiacal light experiment's sensors view the region opposite that of the spacecraft's antenna mast assembly.

turned on during the fourth Australian pass, and three good ranging measurements were obtained. The spacecraft spin rate was then stabilized at 60.591 revolutions per minute.

With the completion of the Step II maneuver, the Helios-2 spacecraft had achieved its final orientation, which would be maintained throughout the life of the mission.

After six days of initial operation, the Helios-2 spacecraft was in its cruise phase. All spacecraft systems had been checked out and were providing excellent data. Good downlink power levels and stable spacecraft temperatures prevailed. All booms, extendable antennae, and the high-gain antenna (HGA) had been successfully deployed or pointed, and working as planned. The Helios-2 mission was well on its way with an expected perihelion of 0.29 AU on 17 April 1976.

On 30 January 1976, the GSOC Helios-2 backup spacecraft team terminated activities at JPL and departed for Germany. According to plan, support by the JPL MOS organization was reduced to the level required for cruise phase, and Phase I of the Helios-2 mission was successfully completed. A discussion of Helios-2 mission Phase II follows in Part B of this Volume.

PART B
DSN SUPPORT OF HELIOS-1 AND -2
MISSION PHASES II AND III

IV. HELIOS-2 MISSION PHASE II

A. FIRST INFERIOR CONJUNCTION

The orbit of Helios-2 was such that the spacecraft entered inferior conjunction on 23 March 1976, when DSS 44 first observed the grayout effects. On 24 March 1976, the spacecraft crossed in front of the Sun's photosphere, at which time DSS 61 observed a total telecommunications blackout and no useful data were obtained. DSSs 43 and 61 observed the grayout effects on 25 March as the spacecraft exited the inferior conjunction region. Telemetry data, special system noise temperature stripchart recordings, and doppler data (one per second) samples and unfiltered automatic gain control (AGC), obtained by DSSs 11, 42, 43, 44, and 61 during the two grayout periods, were added to the DSN data base compiled by Helios-1 and Pioneers 10 and 11, for generating excessive system noise temperature (SNT) predicts. These data were then shipped to JPL where they were analyzed. The data presented in Table 18 has been condensed to the period just prior to and following inferior conjunction and includes the following:

- (1) T_{tot} (excess SNT due to the Sun plus excess SNT due to ground station antenna elevation plus the inherent noise in the receiver, T_z).
- (2) T_{sun} , actual (where the effects other than the increase due to the Sun are removed, excepting any quadripod effects).
- (3) T_{sun} , predicted (determined from data previously gathered).
- (4) Signal-to-noise ratio (SNR) degradation, actual (based on the predicts in Link Analysis and Prediction Program (LAPP) (correcting only for the actual T_z and the antenna elevations)).
- (5) SNR degradation, predicted (based on the predicts in LAPP (correcting only for the actual T_z and the antenna elevations)).
- (6) SNR degradation, corrected (based on the predicts in LAPP (correcting for the actual T_z and the antenna elevations plus the predicted T_{sun})).
- (7) Sun-Earth-probe (SEP) angle.

From the analysis, conclusions were drawn that:

- (1) The experienced increase in SNT correlated quite well with the predicted increase in SNT.
- (2) There was a high correlation between the expected SNR degradation and the degradation experienced (when corrected for expected T_{sun}).
- (3) The signal level degradation and the excess SNR degradation (corrected SNR degradation) were due to decreased receiver loop margin causing increased phase jitter.

Table 18. Solar conjunction data for Helios-2

DSS	T _Z , K	Day of year (DOY)	Time, GMT	SEP angle, deg	Antenna elevation, deg	T _{tot} , K	T _{sun} , K	Predicted T _{sun} , K	Actual ^a SNR degrad, dB	Predicted ^a SNR degrad, dB	Corrected ^b SNR degrad, dB	
44	35.5	082	2300	2.46	30	55.5	13.5	10	-0.6	0-2	+0.3	
			083	0000	2.40	40	56.0	16.6	11		-0.9	+0.1
			0100	2.33	48	58.0	19.9	12	-1.1		+0.1	
			0200	2.27	52	61.0	23.4	13	-1.9		-0.7	
			0300	2.21	51	64.0	28.5	14	-1.7		-0.3	
			0400	2.15	46	65.5	27.1	15	-1.9		-0.5	
			0500	2.08	37	69.5	29.5	18	-1.8		-0.3	
			0600	2.02	26	71.0	27.5	21	-2.0		-0.4	
			0700	1.96	15	86.0	36.6	25	---		---	
		61	35.3	083	0700	1.96	6.9	---	---		25	-4.7
0800	1.90				18	---	---	30	-5.7	-0.6		
0900	1.83				29	---	---	33	-5.1	-2.4		
1000	1.77				39	---	---	36	---	---		
1100	1.71				46	---	---	39	---	---		
1200	1.65				51	---	---	42	---	2-5		
1300	1.59				51	---	---	44	-4.1	---		
1400	1.53				46	---	---	46	---	---		
1500	1.47				38	---	---	48	---	---		
42	33.7	083	2200	1.03	20	78	33.5	80	-4.7	3-6	-1.0	
			083	2300	0.97	31	117	77.1	90		-5.8	-1.8
		084	0000	0.91	41	181	143.6	100	-8.1		4-8	-2.5
			0100	0.85	49	206	169.8	180	-10.0			-2.3
			0200	0.79	53	323	287.3	270	-12.1			-2.8
			0300	0.73	51	420	384.1	300	-13.1			-3.3

Table 18 (contd)

DSS	T _z , K	Day of year (DOY)	Time, GMT	SEP angle, deg	Antenna elevation, deg	T _{tot} , K	T _{sun} , K	Predicted T _{sun} , K	Actual ^a SNR degrad, dB	Predicted ^a SNR degrad, dB	Corrected ^b SNR degrad, dB
42	33.7	084	0400	0.67	45	578	541.3	430	-14.1	6-12	-3.0
			0500	0.61	36	1090	1051.6	450	-16.6		-5.5
			0600	0.54	25	1913	1870.9	500	-19.8		-8.7
			0700	0.48	14	2485	2436.6	700	---		---
61 ^c	35.3	084	0700	0.48	14	1640	1590.0	700	---	6-12	---
43	22.6	084	2200	0.43	21	1065	1035.9	1200	-20.6	6-12	-4.2
			084	0.49	33	1230	1204.5	700	-20.0		-3.5
			085	0.55	42	730	705.8	500	-19.0		-4.4
			0100	0.61	50	660	636.4	450	-19.0		-5.6
			0200	0.67	53	720	696.6	430	-19.1		-6.9
			0800	1.08	20	100	52.9	70	---		3-6
61	36.3	085	0900	1.09	31	75	32.5	66	-5.5	3-5	-1.2
			1000	1.15	40	65	24.8	62	-5.7		-1.3
			1100	1.21	47	65	26.0	58	-5.3		-0.9
			1200	1.27	51	65	26.5	55	---		---
			1300	1.33	50	---	---	53	-5.8		-1.9
			1400	1.39	45	---	---	51	-5.2		-1.8
			1500	1.45	36	65	23.9	48	-4.9		-1.2
			---	---	---	---	---	---	---		---
11	34.5	085	1800	1.62	48	34.0	---	43	-4.6	2-5	-0.7
			1900	1.68	54	34.0	---	42	-4.6		-0.7
			2000	1.74	56	36.0	---	40	-5.4		-1.8
			2100	1.80	52	35.0	---	36	-5.0		-1.5
			2200	1.86	44	32.0	---	32	-4.8		-1.1

Table 18 (contd)

DSS	T_z , K	Day of year (DOY)	Time, GMT	SEP angle, deg	Antenna elevation, deg	T_{tot} , K	T_{sun} , K	Predicted T_{sun} , K	Actual ^a SNR degrad, dB	Predicted ^a SNR degrad, dB	Corrected ^b SNR degrad, dB
44	34.8	085	2300	1.92	34	87.5	47.4	28	-3.3	2-5	-0.5
	34.8	086	0000	0.98	43	74.5	36.3	25	-3.1	1-3	-0.1

^aBased on T_z and antenna elevation effects only.

^bBased on T_z , antenna elevation plus predicted T_{sun} .

^cOut-of-lock SEP angles ≤ 0.43 deg, SNT ≥ 1500 K, predict SNT ≥ 1500 K, 0800Z to 2200Z, DOY 084.

B. MU-II RANGING SUPPORT FOR HELIOS

A meeting was held between representatives of the DSN and Project Helios experimenters at JPL in December 1975 to discuss the availability of the Mu-II ranging equipment at DSS 14 to support the passive experiments (Experiments 11 and 12). As a result of this meeting, an agreement was drawn up whereby the DSN would investigate what the impact would be on DSS 14 and the Viking Project. On 27 January 1975, an official request was received by the DSN from the U.S. Helios Manager to have the Mu-II system installed at DSS 14 by 1 April 1976, if possible. By 2 February 1976, the DSN had a proposed ranging configuration (Fig. 11) and an implementation and testing schedule (Table 19) prepared. All that remained was to negotiate with the Viking Project for a modification to their Planetary Ranging Assembly (PRA) ranging configuration. After much discussion, an agreement was reached with the Viking Project. On 26 March 1976, DSS 14 was authorized to install and perform initial checkout of the Mu-II equipment on 30 March 1976, complete a Mission Configuration Test (MCT) on 13 April, and perform a demonstration pass with either a Helios or Viking spacecraft on 14 April 1976.

The installation and initial checkout was completed on schedule. However, on 8 April, 5 days before the scheduled MCT, the DSN Block IV Receiver-Exciter Subsystem at DSS 14 was declared inoperative. In order to meet previous ranging commitments, the station was instructed to switch to the Block III-PRA configuration. Because the Block IV problem was expected to be resolved within 4 days, the Mu-II MCT and demonstration pass schedules were not changed.

The changeover from Block IV to Block III configuration was made, and an investigation was begun on the Block IV problem. By 12 April, the problem, a momentary dropout on the uplink frequency, had been isolated and corrected. The ranging configuration was switched back to the Block IV Receiver-Exciter and Mu-II on 13 April, and the MCT was successfully conducted. A 3-hour DRVID Stability Test, however, had to be cut short by approximately 30 minutes due to a station power failure.

Based on the overall results of the MCT (Range Data Noise, DRVID Noise, and DRVID Stability Tests), the Mu-II Ranging System was considered ready for the demonstration tracking pass.

As scheduled, the Mu-II ranging demonstration pass was held on 14 April using the Helios-2 spacecraft during its pass over DSS 14. Declared a success, the Mu-II configuration became the prime ranging configuration for both the Helios and Viking Projects.

The dual-channel Mu-II Ranging System was designed as a stand-alone unit, which incorporated a minicomputer to control the ranging system, perform all calculations, and provide both local and remote output for operators and experimenters. The use of a minicomputer had a material influence on the portability, versatility, and reliability of the ranging system. Because the system was not tied to a particular computer installation, there were no computer scheduling or interface conflicts during the testing phase at JPL or DSS 14. Further, the system's enhanced portability facilitated its use in the calibration and testing of other DSN and spacecraft subsystems. Because computer malfunctions could be corrected merely by replacing a chassis, reliability was greatly increased.

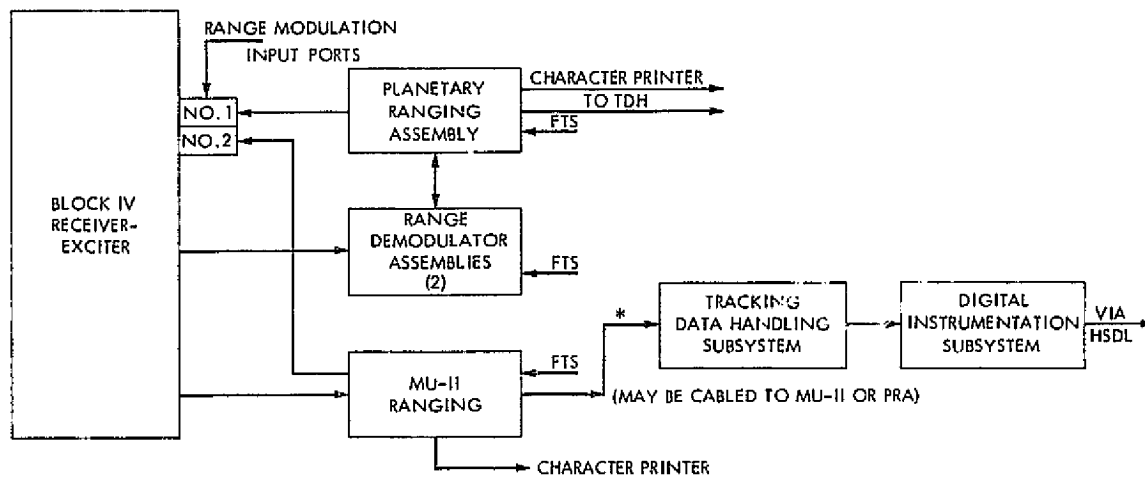

*TRACKING DATA HANDLING INPUT COULD BE RECABLED TO THE PLANETARY RANGING ASSEMBLY WITHIN 24 HOURS

Fig. 11. Proposed ranging configuration at DSS 14

REPRODUCIBILITY OF THE ORIGINAL PAGE IS POOR

Table 19. Proposed implementation schedule for Mu-II ranging support

Event	Implemented and tested by
Installation (including testing) of Mu-II ranging at DSS 14	9 April 1976
End-to-End Data System Test	12 & 13 April 1976
Demonstration pass (Helios or Viking)	14 April 1976
Operational support with Mu-II ranging	15 April 1976

The physical system interfaces were partitioned into two groups: those interfaces internal to the system, and those mating the system to its environment. The internal interface exists, in particular, between the ranging chassis and the minicomputer. This interface was designed with a view toward making the ranging chassis computer independent, thereby facilitating system operations with different computers.

The relation of the Mu-II equipment to other DSN ground-based subsystems and to a Helios spacecraft is shown in Fig. 12. The ranging process starts with the generation of the range code in the transmitter coder. Derived from a 66- or 132-MHz frequency reference by successive division by powers of two, the appropriate code is selected by the ranging computer. This code is phase-modulated onto the uplink carrier and transmitted to the spacecraft. A transponder aboard the Helios spacecraft, which is phase-locked to the uplink carrier, multiplies the carrier frequency by 240/221 to develop the S-band downlink carrier. Concurrently, the received range code is coherently detected, filtered in a 1.5-MHz low-pass channel, hard-limited, and used to remodulate the downlink carrier. Note that two-way doppler will be affected by the carrier frequency multiplication, whereas the range code will not. The downlink signal is received by either a Block III or Block IV receiver, phase-locked to the S-band carrier. The receiver provides 10-MHz IF signals modulated with the range code to the Mu-II. Utilizing these codes, the Mu-II measures the S-band range. The Mu-II has two separate and identical range channels, one for S-band, and one for X-band -- however, the X-band is not used for Helios since those spacecraft do not have X-band capability.

The range code received differs from that transmitted by (a) phase delay due to range, (b) frequency change due to Earth-spacecraft relative doppler, and (c) lesser phase and frequency variations due to the transmission medium. It is impossible to determine the phase difference of two squarewaves whose frequencies are not identical. Therefore, before range can be determined, the doppler effect must be removed. The Mu-II uses a second coder, termed the receiver coder, to accomplish this. In all respects this coder is identical to the transmitter coder. The codes it generates are based upon the same 66- or 132-MHz reference. Just prior to completion of one round-trip

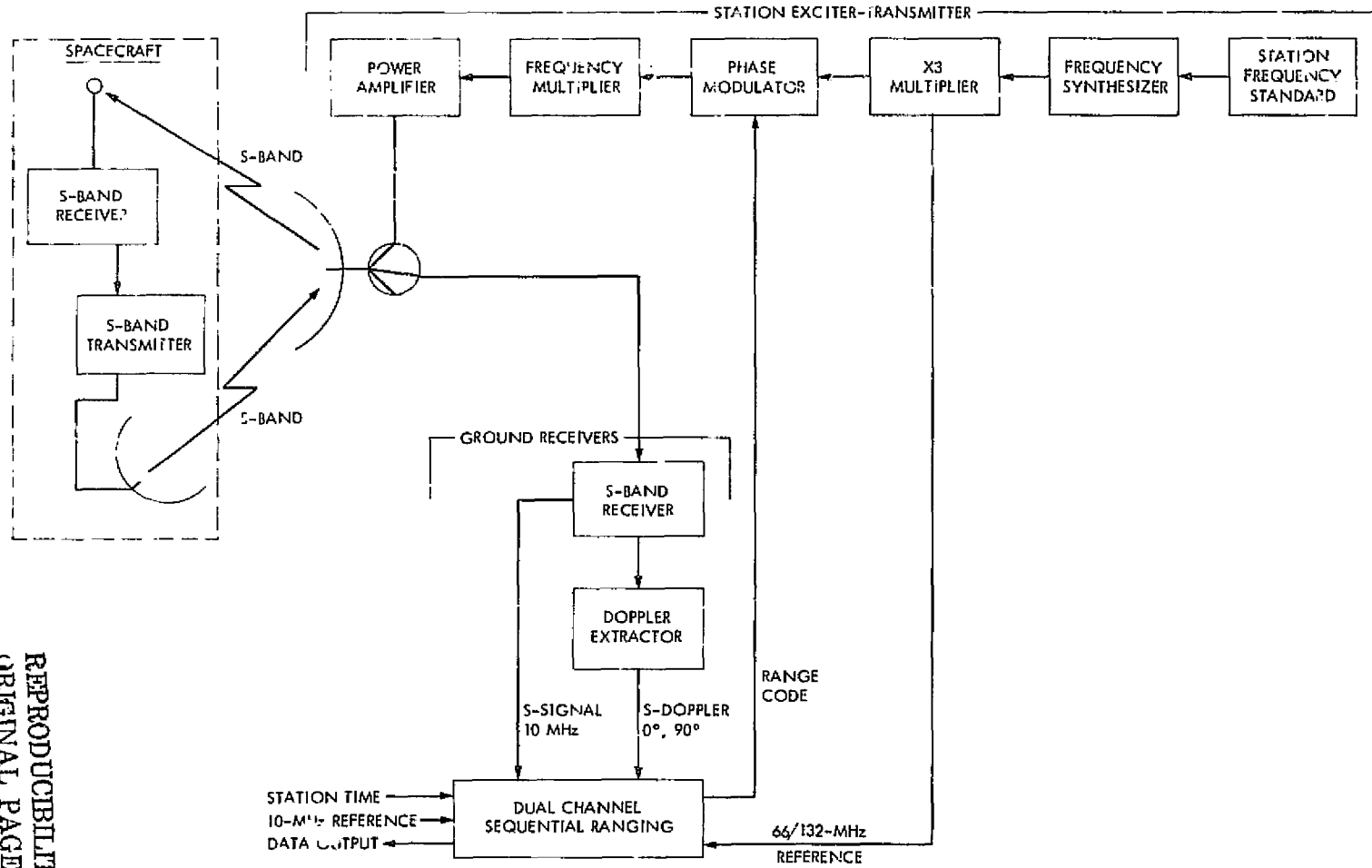

Fig. 12. Station-spacecraft configuration

REPRODUCIBILITY OF THE
ORIGINAL PAGE IS POOR

light-time (RTLT), after start of the ranging, the receiver sequence coder is synchronized to the transmitter coder. Their respective outputs are made identical. Following synchronization, however, the receiver coder's count rate is modified by adding properly scaled doppler from the Block IV (or III) doppler extractor to the 66- or 132-MHz reference. This process, known as doppler rate aiding, causes the receiver coder to instantaneously become a frequency-coherent model of the receive signal. In other words, it becomes identical to what the transmitted code would be if the transmitted code were modified by doppler. The necessary code phase measurement can be made at leisure since the received code and the receiver coder output remain in a fixed phase relationship. The resulting range determination is equivalent to the "backward looking" time of flight at the instant that the receiver coder becomes rate-aided. This instant is called T_0 .

To mechanize the code phase measurement, two correlation voltages are computed for each channel. The first voltage, called the in-phase voltage, is a direct comparison of the received code with the receiver coder output. The second voltage, called quadrature voltage, is an analogous comparison of the received code with the receiver coder output delayed by one-quarter of a code period. The ranging algorithm first determines the phase delay for the highest frequency code to establish the range measurement precision. The same determination on a series of lower frequency codes resolves the range ambiguity. Because each code is derived from the same binary counter, they are phase-coherent. Therefore, it is not necessary to measure the phase of any component except the first one.

Range measurement is affected in two ways due to the charged-particle plasmas, both ionospheric and interplanetary, which corrupt the received signal. First, the range modulation is decreased in frequency (thereby corrupting code phase), and, second, the carrier is increased in frequency by a like amount (thereby corrupting doppler). This causes a slow drift of the measured phase delay.

The measured drift, known as DRVID (Differential Range Versus Integrated Doppler), can be used to determine the time rate of change of the total columnar electron content of the ray path. To measure this drift and to redetermine the initial phase measurement, after the range acquisition is complete, the ranging program repeats the highest frequency component and remeasures its phase delay. Although these remeasurements can be performed at the correlation function peak, up to a 5-dB improvement in performance is obtained by retarding the receive coder by one-eighth of the code period. This is the "equal-power" point, where both the quadrature and in-phase voltages have equal magnitude. To further increase the amount of DRVID data, the highest frequency component is, at the experiment's option, transmitted concurrently with all low-frequency components, except the second, during the resolution of range ambiguity. DRVID data are then available throughout the ranging acquisition.

If the charged-particle induced drifts are large enough, the code phase will be driven significantly from its proper operating point on the correlation function. To prevent this, a code servo, implemented in software, with loop gain of 0.25 is employed to retain proper code phase alignment. The servo routine provides a correction factor to the range calculation so that coder moves, i.e., servo actions, do not mask or corrupt the real charged-particle effects.

While the ranging algorithm has remained essentially unchanged, the Mu-II system represents a marked advance and departure from earlier systems in the mechanization of the range code demodulation and correlation. Whereas earlier systems, including the Mu-I and the Planetary Ranging Assembly (PRA), were purely analog, the Mu-II is wholly digital.

The Mu-II system was programmed by an advanced software system. Developed and refined from the Mu-I software program, this new system was designed to support virtually any mission ranging requirement. The primary features of the Mu ranging programs are (1) automatic reacquisition of the range code, (2) reacquisition of the range code without disturbing acquisitions already in the ray path, and (3) a flexible, efficient operator interface.

In developing the new software for the Mu-II, there were four primary design goals:

- (1) Ease of Operation. The operator interface had to be easy to learn and simple to operate. It had to be amenable to operators of varying degrees of skill and interests.
- (2) Efficient Use of Operator. The operator was not involved in "busy-work" calculations. The program has to make efficient use of the operator's time.
- (3) Local Visibility. The operator or experimenters had to have sufficient local visibility to confirm and assure proper system operation.
- (4) Modular Construction. The software had to be constructed in interrelated but well-defined modules to facilitate repair, reliable operation, and developmental expansion.

Operationally, this new ranging system requires only about half the support of that required by the PRA and, because it is fully automatic, requires no manual calibration (10 MHz phasing). In addition, any changes required in operating parameters can be accomplished in approximately 30 seconds.

The Mu-II Ranging System provides the DSN with the capability of probing the solar corona and surrounding plasma and gravitational fields during solar conjunctions to provide new scientific and technological information that can not be obtained by any other means.

C. FIRST PERIHELION PASSAGE

On 8 April 1976, the Helios-2 spacecraft started its 25-day perihelion passage. At the time Helios-2 was transmitting from traveling-wave tube amplifier 1 (TWTA-1) in the high-power mode when it was noticed by the Spacecraft Operations Team (SOT) that the helix current had reached its hard limit.

The SOT directed that TWTA-1 be switched from high power to medium power. All TWTA-1 parameters for medium-power mode were normal, but, after careful analysis of the situation by the SOT, it was decided to command the transmitter to TWTA-2, medium power, for the balance of the primary mission.

Helios-2 passed its first perihelion on 18 April 1976, at 0229 GMT at a distance of 0.29 AU from the Sun, nearly 3 million kilometers (2 million miles) closer to the Sun than Helios-1, and experienced approximately 10% more heat.

DSS 42 in Australia supported the perihelion pass and reported (a) receipt of coded scientific telemetry data at the rate of 2048 bps, (b) telemetry downlink signal level at -148 dBm, (c) signal-to-noise ratio at 4.281 dBm, and (d) that solar heat intensity had reached 11.8 solar constants. The Earth-Sun-probe angle at perihelion was reported as 86.87 degrees.

Two days after perihelion, 20 April 1976, the SOT decided to command TWTA-2 from medium power to high power for 45 minutes. During that time TWTA-2 reached its hard limit and had to be switched back to the medium-power mode.

After extensive testing, the helix current limits were redefined by the German SOT and on 29 April at 1430 GMT, the Helios-2 TWTA-2 was commanded to the high-power mode. The newly defined TWTA-2 helix current limits were soon reached and remained stable.

On 30 April 1976, Helios-2 exited its perihelion passage and began its approach to first solar superior conjunctions with all spacecraft subsystems and experiments performing well and the spacecraft spin stabilized at 60.53 revolutions per minute.

D. ENTRANCE INTO FIRST SOLAR SUPERIOR CONJUNCTION

On 4 May 1976, the Helios-2 spacecraft began its first solar superior conjunction passage at a Sun-Earth-probe (SEP) angle of 5.11 degrees. During this superior conjunction, in which the spacecraft would experience three solar occultations and last until 6 October 1976, the DSN conducted a special telecommunications study to answer the following questions:

- (1) What increase in system noise temperature could be expected due to small SEP angles; and would these compare to past solar conjunctions?
- (2) To what extent would the AGC and SNR be affected by the small SEP angles; how well could these be predicted; and what RF and Subcarrier Demodulator Assembly (SDA) bandwidths would be best for minimizing degradation?

To study the effects of this superior conjunction period on the performance of the DSN, two special data-gathering activities were planned. The first consisted of special system noise temperature chart recordings, and the second consisted of spectral broadening test. The results of this special study will be discussed in Volume III of this series.

On 14 May 1976, the German 100-meter station (called station 67) reported that at 1140 GMT the station had lost the downlink signal from Helios-2 at an SEP angle of 0.625 degrees. Three hours later, at 1445 GMT, DSS 14 at Goldstone reported that they also had lost the Helios-2 downlink signal at an SEP angle of 0.586 degrees.

The Helios-2 spacecraft had successfully completed Mission Phases I and II (Fig. 13) and was entering into Mission Phase III.

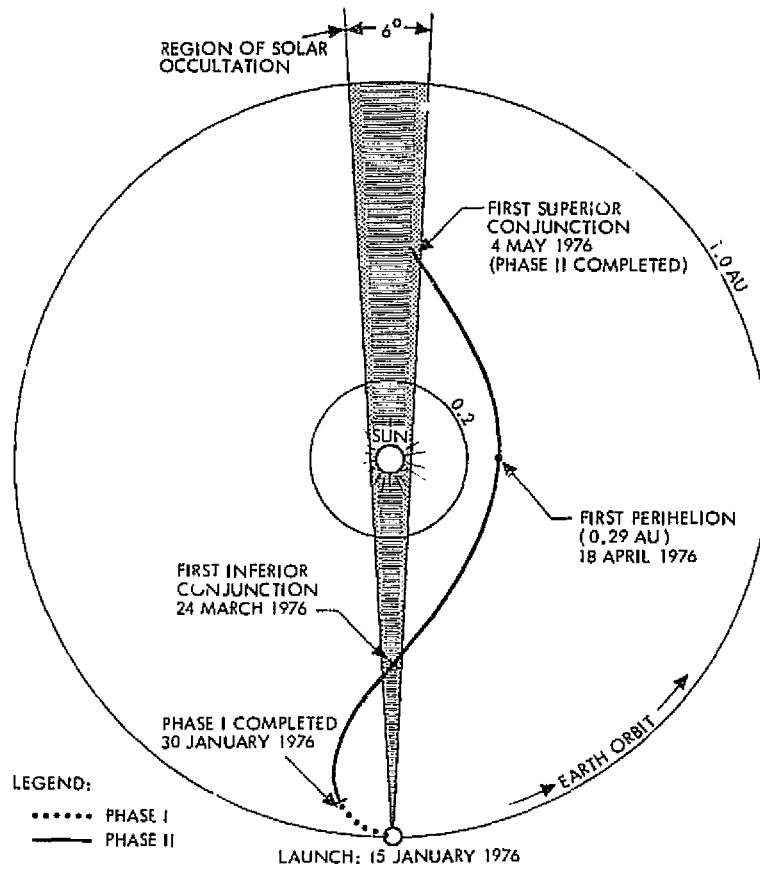

Fig. 13. Helios-2 trajectory, Mission Phases I and II

V. HELIOS-1 MISSION PHASE III

A. GENERAL

Volume I of this series covered the DSN support of Helios-1 from launch on 10 December 1974 until the end of Mission Phase II on 13 April 1975, when the Helios-1 spacecraft began its first superior conjunction passage. The end of Mission Phase II, the primary mission phase, marked the beginning of Mission Phase III, during which time DSN operational support activities decreased. This section of Part B, Volume II, records the DSN planning and operational support provided Helios-1 from 13 April 1975 until May 1976.

B. FIRST SUPERIOR CONJUNCTION

The Helios-1 superior conjunction was highly unusual as compared to those of previous spacecraft, which were more nearly solar polar passes. The unique Helios trajectory (Fig. 14) provided an orbital inclination of 0.016 degree and offered the Helios Radio Science Team their first opportunity to measure solar and corona effects upon the radio-frequency (RF) path, which was within the plane of the ecliptic during a superior conjunction.

The Helios-1 spacecraft entered its first superior conjunction passage on 7 April 1975 with a Sun-Earth-probe (SEP) angle of 5 degrees and exited on 24 June 1975. The SEP angle decreased to 3 degrees on 13 April and diminished to 0.43 degree on 6 May 1975, when a total telemetry blackout occurred due to solar corona degradation of the telemetry data. Figure 15 shows the period of telemetry blackout experienced by both the 26- and 64-meter DSN stations. As noted, the telemetry blackout at the 64-meter stations was not as severe as at the 26-meter stations. Due to the narrower antenna beamwidths at the 64-meter stations, the blackout period only lasted 14 days (2 through 15 May 1975), as compared to 29 days (25 April through 23 May) at the 26-meter stations.

Superior conjunction for Helios-1 differed from those of Pioneers 10 and 11 (SEP 1.9 degrees) in that the spacecraft passed completely behind the solar disk, resulting in a total telecommunications blackout. This blackout period is also known as solar occultation.

As mentioned in Volume I, the DSN was interested in compiling a reliable data base from which to generate predicts on excessive system noise temperature (SNT), signal levels, and SNRs versus SEP angles. To this end plans were made and implemented throughout the DSN to gather and record as much superior conjunction data as possible. Early analysis of the data collected revealed the following:

- (1) Degradation of the downlink signal level increased as the SEP angle decreased to less than 2 degrees. At an SEP angle of 1.5 degrees, the degradation was approximately 3 dB and reached a maximum of 23 dB as the SEP angle diminished to 0.43 degree.
- (2) The 26-meter stations observed a high SNR of 94 K at an SEP angle of 1.05 degrees.

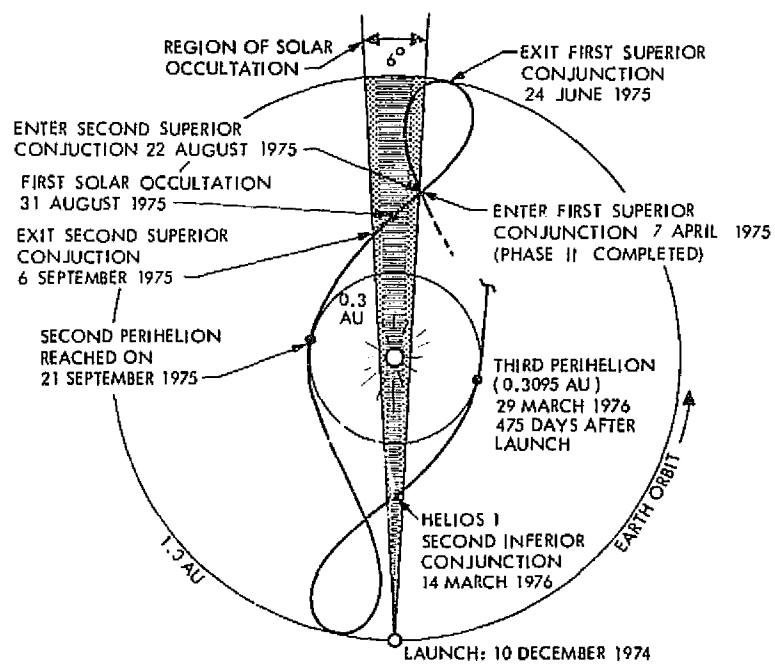

Fig. 14. Helios-1 trajectory, Mission Phase III

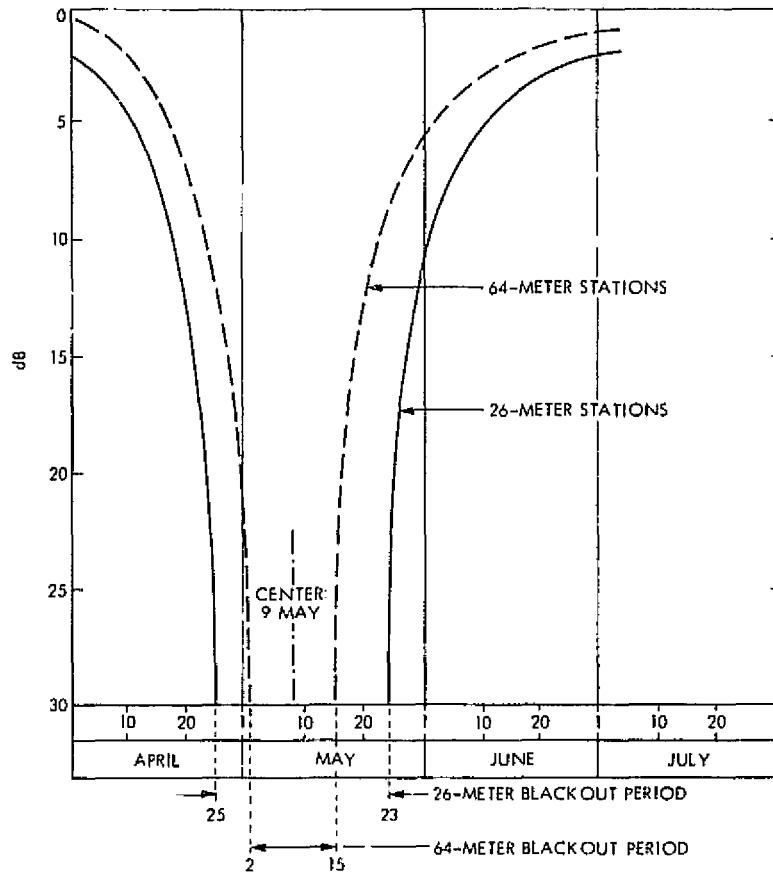

Fig. 15. Helios-1 telemetry degradation at superior conjunction

- (3) The 64-meter stations observed a high SNT of 1685 K at an SEP angle of 0.41 degree.
- (4) Both the 26- and 64-meter stations observed that the SNR degradation approached 25 dB at an SEP angle of 1.5 degrees and experienced a complete telemetry blackout as the SEP angle diminished to 0.43 degree.

Analysis of the data gathered during the Helios-1 first superior conjunction has not been completed at the time of this writing. The final results will be combined with those of Helios-2 and discussed in Volume III of this series.

The Helios-1 tracking coverage provided by the DSN, commencing with the start of superior conjunction on 13 April, was substantially less than planned. Only 79 tracks were supported by the DSN, while theoretically 177 tracks were available. This was primarily due to the telemetry data blackout caused by solar effects when the Earth/spacecraft line was near the Sun.

Prior to the launch of Helios-1, 82 tracks had been forecast in the long-range schedule, but the forecast had provided less coverage than desired at the entry and exit of solar conjunction, and more than was required during the telemetry blackout phase. To rectify this and to obtain a more operationally desirable superior conjunction tracking schedule, the tracks during solar blackout were negotiated away to other projects in return for tracks that would fulfill the Helios requirements. The actual coverage provided by the DSN during first superior conjunction satisfied Project requirements.

C. SECOND SUPERIOR CONJUNCTION

The second Helios-1 superior conjunction began on 22 August 1975 and ended on 6 September 1975, a total of 16 days, with solar occultation occurring on 31 August 1975 (Fig. 14). The superior conjunction occultation period is determined by the amount of time that is necessary for the spacecraft trajectory to cross from occultation entry minus 3 degrees, through solar conjunction, to exit plus 3 degrees, within the ecliptic plane. Due to increased spacecraft velocity as it approached perihelion, the second superior conjunction was relatively short (16 days) as compared to the first, which took 56 days to traverse this "blackout" region. The second blackout period started on 22 August and extended through 6 September 1975. The spacecraft was configured for blackout 2 days earlier than planned, when unexpected solar interference was encountered at a Sun-Earth-probe (SEP) angle of 3.65 degrees. A detailed spacecraft analysis was initiated by the German Control Center (GCC) when the spacecraft's downlink signal-to-noise ratio was unexpectedly degraded by 2 dB. The analysis revealed that the degraded performance could be attributed only to solar interference, which was much more intense than anticipated. During the time in which the spacecraft was configured for blackout operation, the Goldstone 64-meter station (DSS 14) was denoted the prime station for support of radio metric and polarimetry data. In addition to project requirements, the DSN Tracking and Telemetry Analysis Groups continued their own parallel studies of the observed radio metric and spectral broadening effects resulting from the varied solar phenomena.

REPRODUCIBILITY OF THE
ORIGINAL PAGE IS POOR

D. SECOND PERIHELION

The second perihelion phase started 4 days after the termination of the second superior conjunction. The second Helios-1 perihelion occurred at 1216 GMT (0516 PDT) on 21 September 1975. The perihelion phase includes perihelion plus and minus 12 days while the probe gathers scientific data within the environs of our solar sphere. DSN support provided during the second perihelion was not continuous, as during the first perihelion, but the tracking coverage was substantial. The Goldstone 64-meter station did provide daily coverage during September; the Madrid 64-meter station, which was scheduled for the first time for Helios-1 support, covered six tracking passes at their longitude during the September portion of the second perihelion phase. DSN 26-meter station support was scheduled to complete the coverage requirements when their services were not committed to flight projects with higher priority than Helios-1.

The DSN long-range Helios-1 forecast had requested 101 tracking passes within the second superior conjunction and second perihelion time frame. This requested coverage had projected continuous coverage throughout the second perihelion period. Due to higher priority commitments to other flight projects, continuous coverage for Helios-1 was not available. Nevertheless, DSN operations supported 122 Helios-1 tracking passes during this period of 62 days, in which a total of 186 tracks were potentially available. The total request supported equalled 54% of the potentially available DSN tracks with 66% being actually supported, for a total of 927.2 hours of coverage. Total support during this period had a slight drop from the superior conjunction period, but there was a 16-day blackout period where only DSS 14 was required to provide 14 days of coverage. The average pass duration changed little and was 7.6 hours long. Support during perihelion increased from 61 to 71% of potentially available tracks, excluding any mission support provided by the German Network during perihelion. The DSN 64-meter stations supported for 626.1 hours out of the total 927.2 hours of coverage. In summary, the total Helios-1 DSN tracking coverage provided to the Helios Project continued to fulfill the total tracking coverage requirements requested.

The overall performance of the spacecraft's subsystems and science instruments during perihelion was excellent. At second perihelion the minimum distance to the Sun was 0.309 AU (46.2885 million kilometers), and the distance to the Earth was 1.01 AU. As expected, the probe encountered slightly higher temperatures during the second perihelion. The increased temperatures were caused by the gradual degradation of the spacecraft skin due to the high-radiation environment.

E. SPACECRAFT EMERGENCY SUPPORT

The Helios-1 spacecraft and its attendant scientific instruments were performing well until a problem was observed on 10 October 1975 within the spacecraft's ranging subsystem. The anomaly occurred during a ranging pass over DSS 14 and was subsequently verified by the Australian and Madrid 64-meter stations. The anomaly was manifested by an apparent absence of ranging modulation on the downlink carrier when all other correlated spacecraft ranging functions appeared normal. Subsequent to Network verification, a special ranging test was conducted on 18 October 1975 at DSS 14. The uplink was modulated with a 500-kHz signal, while a downlink spectrum analysis was performed to determine

if the 500-kHz modulation was detectable. This test revealed that the modulation and a harmonic at 1.5-MHz interval was present but markedly degraded. An investigation was begun into the ranging problem and was still in progress when a Traveling-Wave Tube Amplifier 1 (TWTA-1) failure occurred on 31 October 1975.

Then, on 9 November 1975, with the spacecraft operating in a normal manner, ranging was successfully accomplished by DSS 14 for the first time since 9 October. The sudden return to normal operation of the ranging transponder was a mystery to both the Project and the DSN.

The failure of TWTA-1 manifested itself when an approximate 28-dB drop in the downlink signal level was observed during a spacecraft tracking pass over DSS 11 at Goldstone. The anomaly occurred at 1834 GMT, and, to accelerate isolation, Goldstone DSS 12 support was requested by the DSN. Both stations verified identical downlink signal levels at -167 dBm. This level was below the telemetry threshold for 26-meter stations. The Helios Project declared a spacecraft emergency at 2040 GMT and requested 64-meter support for the impending Australian viewperiod. At 2121 GMT, the Project commanded the spacecraft from the failed high-power TWTA-1 mode (20 watts) to the 10-watt medium-power mode. This seemingly returned the probe back to a normal operational mode. What had been thought of as normal operations was short-lived; a total TWTA-1 failure disrupted the DSS 43 downlink at 2253 GMT. The Project analyzed this failure, and the spacecraft was commanded to the low-power mode (0.5 watt) of operations at 2344 GMT. Once RF lock was achieved, the spacecraft was commanded to 16 bps, and normal operation in this mode was achieved.

With a satisfactory low-power downlink established, the Project continued to analyze the anomaly. The decision to switch to TWTA-2 medium-power mode was accomplished at 1610 GMT, 1 November 1975. The spacecraft has operated normally since the switch to TWTA-2. Special DSN surveillance was provided by DSSs 11 and 63 until the spacecraft emergency was terminated during the DSS 11 track of the spacecraft on 1 November 1975 at 2130 GMT.

A Helios Project-sponsored TWTA Failure Analysis Review was conducted at JPL on 12-14 November 1975. The outcome of these meetings produced 14 action items plus 7 recommendations, directed to various Helios team members. The DSN was requested to continue to provide operational information on whether automatic gain control fluctuations are observable within the downlink after the switch to TWTA-2. The Failure Review also illustrated that further investigations will have to be conducted to reach a final conclusion.

On 12 December 1975, DSS 42 observed another ranging anomaly and reported that at times the pseudo-DRVID values for a series of range acquisitions differed by a multiple of 1024 range units. The Spacecraft Analysis Team theorized that this anomaly could be caused by the station transmitting an inverted ranging code. This theory was confirmed when the anomaly was observed in real-time and subsequently confirming that the station had indeed inadvertently instructed the Planetary Ranging Assembly (PRA) to transmit an inverted code to the Helios-1 spacecraft.

Ranging again was nominal for Helios-1 until 28 January 1976, when all ranging attempts failed for the second time (the first occurred on 10 October 1975).

In an attempt to find the cause, the special Helios-1 Ranging Channel Test was performed on 5 March 1976 at DSS 14 (Fig. 16). For this experiment, the ranging uplink channel was modulated continuously with a coherent 250-kHz sine wave instead of the normal pseudo-random code ("square wave"). The Precision Signal Power Measurement (PSPM) equipment was then used to look for any sidebands at the fundamental (S-band frequency minus 250 kHz) first and second harmonics. The visual interpretation of the cathode-ray tube (CRT)-displayed power spectrum showed no ranging sidebands.

The Spacecraft Analysis Team then theorized that the ranging failure was associated with spacecraft temperature. On 17 March 1976, it was again possible to perform ranging on Helios-1. After analyzing the history of the Helios-1 ranging performance, the Spacecraft Analysis Team stated that the ranging transponder did not function when the Very Stable Oscillator (VSO) temperature was between 5°C and 18°C but would function normally when the VSO was above or below this temperature region (Fig. 17).

F. SECOND INFERIOR CONJUNCTION

On 18 February 1975, the DSN experienced a total telecommunications blackout as the Helios-1 spacecraft crossed in front of the Sun's photosphere. One year and 25 days later, 14 March 1976, the spacecraft's heliocentric orbit had again placed the spacecraft in line between the Sun and Earth and caused a total telecommunications blackout to be observed by DSSs 14 and 43.

Because the DSN was still engaged in analyzing solar-generated noise, DSSs 14, 43, and 44 were requested to make system noise temperature stripchart recordings and to gather doppler and unfiltered AGC data when the SEP angle was less than 15 degrees. The data gathered by these DSN stations were shipped to JPL, where they were analyzed. The data presented in Table 20 have been condensed to the period just prior to and following inferior conjunction. These data include T_{tot} (excess system noise temperature (SNT)) due to the Sun, ground station antenna elevation, and inherent SNT in receiver, T_z , T_{sun} (where effects other than the increase due to the Sun are removed -- except for the antenna quadripod effects), and SEP angles (on hourly centers). The analysis suggested that the signal level degradation and higher than expected signal-to-noise ratio (SNR) degradation were probably due to decreased loop margin, which was causing an increase in phase jitter.

G. THIRD PERIHELION

On 17 March 1976, the ranging problem of 28 January corrected itself, and ranging again became possible due to higher spacecraft temperature as the Helios-1 spacecraft began its third closest approach to the Sun.

On 22 March 1976, 7 days before third perihelion, a spacecraft anomaly occurred. At approximately 0726 GMT, during a station gap, Experiment 1 switched OFF. Both high voltages for Sensors A and B of Experiment 10 dropped to zero, and operation of the automatic read-in mode (which was recording data during the gap) stopped. Investigation by the German Spacecraft Team did not determine the specific cause for this anomaly and concluded it was an isolated event. On 25 March, both experiments were commanded ON, and the spacecraft proceeded on toward its third perihelion.

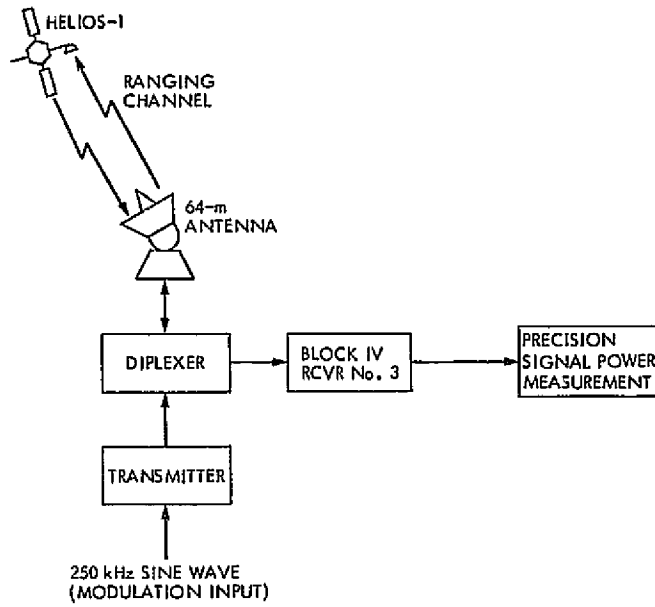

Fig. 16. Helios-1 Ranging Channel Test (DSS 14)

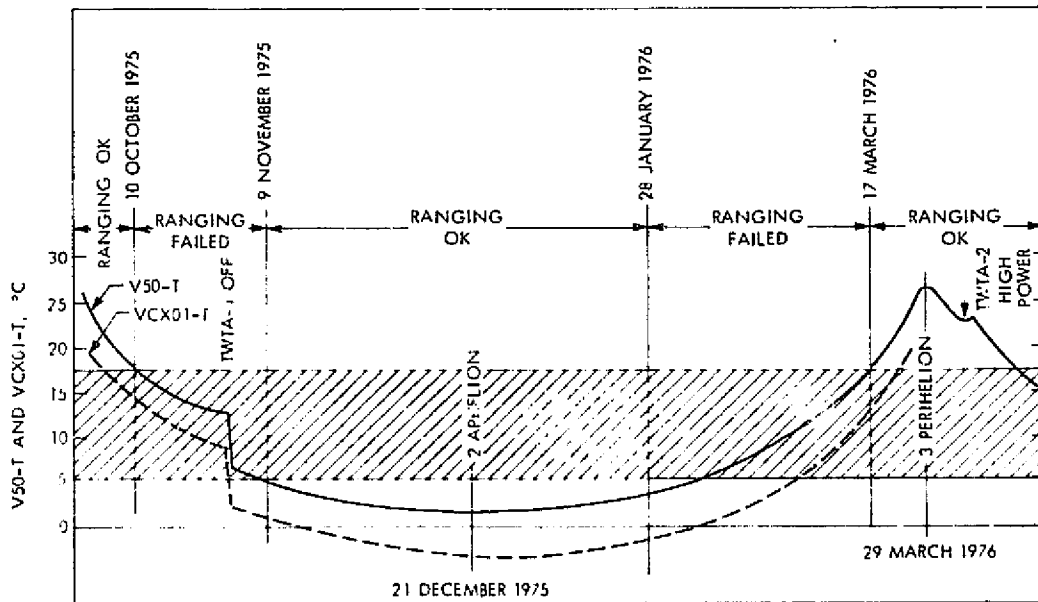

Fig. 17. Helios-1 ranging problem vs VSO temperature

Table 20. Helios-1 second inferior conjunction telemetry data

DSS	T_z, K	Day of year (DOY)	Time, GMT	SEP angle, deg	Antenna elevation, deg	T_{tot}, K	T_{sun}, K	Predicted T_{sun}, K
43	23.5	071	2200	3.72	20	35.1	4.7	0
			2300	3.64	31	31.2	4.4	0
		072	0000	3.56	42	32.0	6.9	1
			0100	3.48	51	28.8	4.4	1
			0200	3.40	56	33.2	9.1	2
44	37.1	072	2300	1.96	33	65.0	22.3	33
			0000	1.89	43	69.5	29.1	35
		073	0100	1.80	52	85.0	45.8	38
			0200	1.72	56	105.0	66.2	41
			0300	1.63	55	115.0	76.1	45
14	19.3	073	1600	0.57	23	460	435.0	700
			1700	0.49	34	630	608.0	900
			1800	0.41	43	1800	1780	1200
			1900	0.33	50	6000	5980	≥ 1500
			2000	0.25	52	7600	7580	≥ 1500
44	34.5	074	(out-of-lock, SNT ≥ 1500 K, SEP angles of less than 0.25 , predict SNT ≥ 1500 K)					
14	19.6	074	1600	1.36	23	99.0	73.7	50
			1700	1.44	34	65.0	40.7	48
			1800	1.52	43	40.0	18.9	46
			1900	1.60	50	37.5	16.9	44
			2000	1.68	52	55.0	34.6	42
			2100	1.76	55	36.0	15.7	40
43	22.3	074	2100	1.76	15	52.0	20.1	40
			2200	1.84	20	38.6	3.3	35
			2300	1.92	31	32.5	6.9	30
		075	0000	2.00	42	31.7	7.8	25
			0100	2.08	51	29.8	6.6	22
			0200	2.16	56	59.0	36.1	20
			0300	2.24	55	36.0	13.0	15
			0400	2.31	50	37.5	14.2	13

Helios-1 successfully passed its third perihelion on 29 March 1976 at 1552 GMT (Fig. 18) and proceeded toward its third superior conjunction. The spacecraft at that time was at a distance of 0.933 AU from Earth, and 0.31 AU from the Sun. The temperatures experienced by the spacecraft this time were slightly higher than those encountered during the second perihelion (21 September 1975). However, from the 2048-bps telemetry data received by the 64-meter DSS 14, the spacecraft system's performance was excellent.

The DSN tracked the Helios-1 spacecraft 125 times for a total of 704 hours during this critical scientific phase. Of this total time approximately 54% or 381 hours of coverage was provided by the DSN 64-meter stations.

In addition to the DSN support, the Madrid STDN site also supported the Helios Project during this period by tracking the Helios-1 spacecraft 18 times for a total of 79 hours. During this time period, analog tape recordings of the spacecraft telemetry data were made and later shipped to STDN (MIL 71) (co-located facility at Cape Canaveral Air Force Station), where the recordings were processed and then transmitted via high-speed data line (HSDL) to the Mission Control and Computing Center (MCCC) at JPL for incorporation into the Master Data Record (MDR).

The Madrid STDN support was terminated on 9 April 1976 when the Helios-1 telemetry downlink signal reached recording threshold.

The Goldstone STDN support began on 6 April but was terminated on 5 May 1976 after evaluation of the STDN recorded data indicated an average loss of 8 to 10 dB.

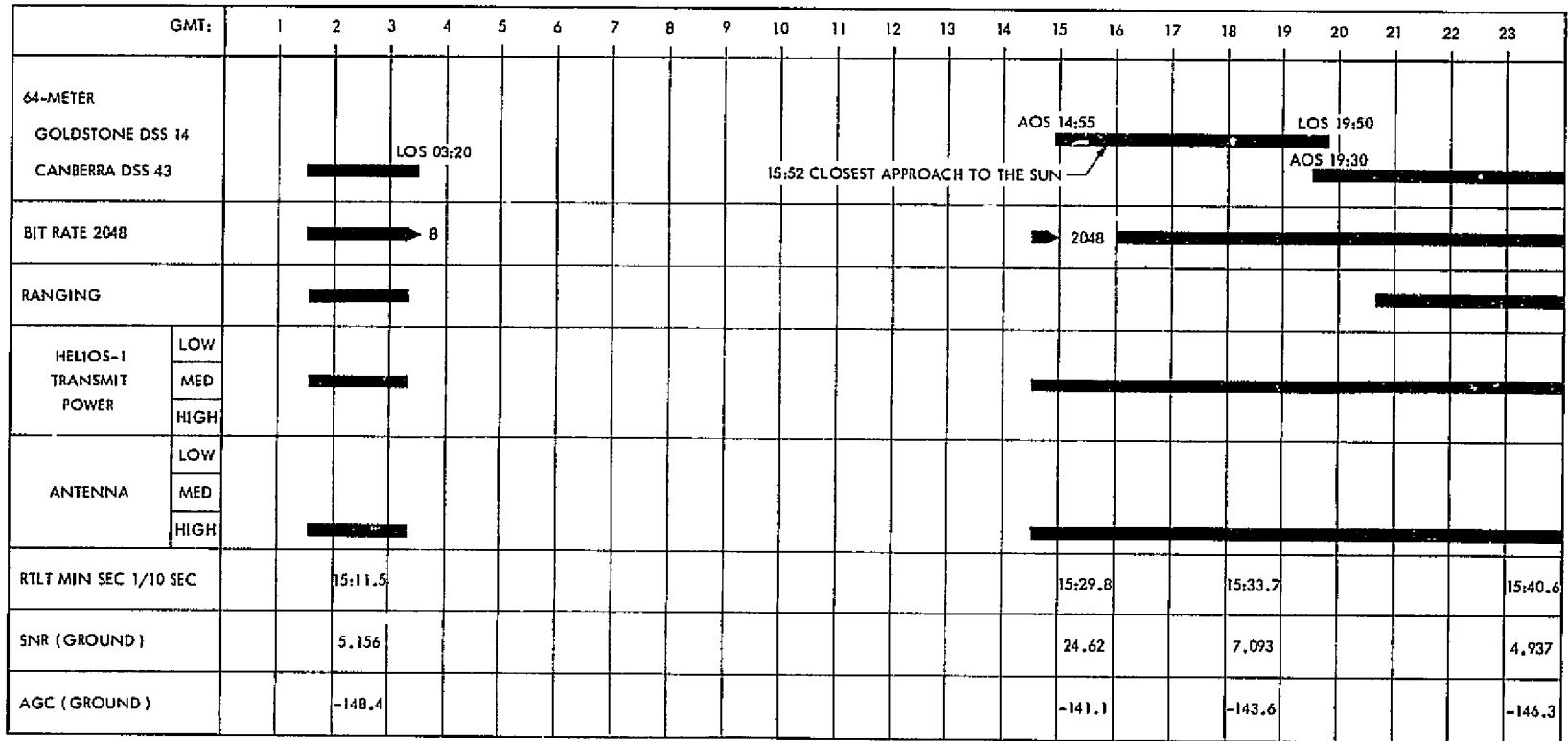

Fig. 18. Helios-1 third perihelion data

VI. DSN SYSTEM PERFORMANCE HELIOS-1 AND -2

A. DSN TELEMETRY SYSTEM PERFORMANCE

The performance of the DSN Telemetry System in support of the Helios Project from April 1975 through April 1976 was consistently above the nominal predicts, averaging approximately 0.5 dB. Then, in May 1976, for no known reason, the average performance for Helios-1 dropped to 0.1 dB above nominal.

Data gathered by the DSN Network Operations Analysis Group during the Helios-1 and -2 inferior conjunctions (March 1976) and superior conjunctions (May 1976) were added to the data gathered from the Pioneer 10 and 11 conjunctions. Results from the detailed analysis of all these composite data will be reported in Volume III of this series.

B. DSN COMMAND SYSTEM PERFORMANCE

The overall performance of the DSN Command System in support of the Helios Project during the one-year time period of April 1975 through May 1976 was excellent. For Helios-1, a total of 24,090 commands were transmitted to the spacecraft with only 11 commands (0.05%) being aborted for a variety of minor reasons. For Helios-2, launched in January 1976, a total of 13,173 commands were transmitted to the spacecraft with only 3 commands (0.02%) being aborted.

Total time devoted to tracking Helios-1 and -2 was 7085.1 hours, out of which the Command System was out of operation due to minor equipment problems for approximately 74.7 hours or 1.05% of the total tracking time.

C. DSN TRACKING SYSTEM PERFORMANCE

The overall performance of the DSN Tracking System in support of the Helios Project from April 1975 through May 1976 was excellent. The highest period of activity during this one-year period was the Helios-1 superior conjunction passage when the doppler noise level was substantially higher than normal due to the spacecraft's proximity to the Sun.

For years the DSN had experienced severe doppler noise when tracking a spacecraft near solar conjunction. During these times, it had been observed and recorded that, whenever the line-of-sight to the spacecraft approached to within 30 to 40 degrees of the Sun, the doppler noise level would begin to increase drastically. As an example, the average noise value used by the DSN for a 60-second sample rate doppler data was 0.003 Hz. However, as a spacecraft signal approached the limb of the Sun, this figure increased to 1 Hz or more, an increase of approximately 3 orders of magnitude, which resulted in the doppler data becoming severely degraded.

Therefore, the Tracking and Data Systems Manager requested that the Network Operations Analysis Group undertake the task of investigating the cause of doppler noise during the upcoming Helios-1 superior conjunction and determining if the occurrence could be predicted.

To investigate the cause of doppler noise during solar conjunction, a sizeable data base was accumulated from data taken during the solar conjunctions of Pioneer 10, Pioneer 11, and Helios-1 spacecraft. This data base consisted of the "average doppler noise" value for each spacecraft during its daily pass over the DSN 26- and 64-meter stations. The "average" was obtained from good, two-way, 60-second doppler data by manually scanning the pseudo-residual output for each pass and then selecting the three smallest groups of noise values. From these three groups, an average value was estimated and recorded, and then the three group estimates were averaged to produce a "pass average." The "pass average" values were then plotted as a function of both Sun-Earth-probe (SEP) and Earth-Sun-probe (ESP) angles as seen in Table 21 and Figs. 19 and 20 for Helios-1. At this point the investigators made two assumptions which could then be combined to form an independent variable for correlations and prediction of solar-induced doppler noise. The two assumptions were:

- (1) That signal corruptions were proportional to the length of time the signal is exposed to electromagnetic energy flux and charged particles.
- (2) That signal corruptions were proportional to the intensity of the electromagnetic energy flux and charged particles at any given instant in time.

This led to the development of a Doppler Noise Model, which was a simple geometric parameter that correlated very strongly with doppler noise under varying SEP angles. Figure 21 shows the strong correlation existing between the DSN-observed doppler noise and the integrated solar intensity (ISI) parameter for the Helios-1 first solar conjunction.

In analyzing their findings, the investigators realized that the parameter they had established was very similar to the total columnar electron content along the signal path.

By changing the doppler noise model slightly to more accurately model the total columnar electron content at a given time between the Earth and spacecraft, the results were found to be even better than the original assumptions. Figures 22 and 23 show the correlation of doppler noise with the new model "integrated solar electron density" (ISED) for the 1975 Helios-1 solar conjunction, while Figs. 24 and 25 show the Helios-1 doppler noise and ISED model versus day of year. The conclusion was that it appeared that the doppler noise observed by the DSN 26 and 64-meter stations was a constant times the total columnar electron content along the signal path. This, then, provided the DSN with a method of predicting the doppler noise level for any arbitrary spacecraft location. With this knowledge the DSN began in late 1975 to provide the 26- and 64-meter stations with monthly solar noise predictions for all active missions so that the stations would know in advance what to expect in the way of doppler noise on any given day of a solar conjunction period. Thus, with this new capability, the DSN had acquired the ability of not only predicting doppler noise but also of validating the generation of doppler data during solar conjunctions.

Table 21. Helios-1 solar conjunction, 1975

Deep Space Station (DSS)	Day of year (DOY)	Average doppler noise, Hz	Sun-Earth-probe angle α , deg	Earth-Sun-probe angle β , deg	Integrated solar intensity (ISI)
12	63	0.0041	16.21	29.90	107
12	75	0.0050	17.17	91.94	311
12	79	0.0197	14.89	114.51	446
12	88	0.0109	9.18	149.12	935
12	89	0.0099	8.61	151.68	1013
12	90	0.0112	8.07	154.03	1097
12	91	0.0198	7.56	156.19	1187
12	92	0.0253	7.06	158.19	1287
12	93	0.0255	6.59	160.03	1394
12	94	0.0727	6.14	161.73	1512
12	95	0.0527	5.71	163.29	1641
12	98	0.1293	4.55	167.28	2109
12	99	0.0790	3.57	170.41	2737
12	101	0.1153	4.21	168.41	2204
12	102	0.2017	3.28	171.30	2994
14	64	0.0044	16.84	33.62	116
14	65	0.0033	17.37	37.64	126
14	66	0.0054	17.80	41.96	137
14	67	0.0031	18.14	46.59	150
14	69	0.0057	18.49	56.74	179
14	70	0.0063	18.51	62.23	196
14	73	0.0037	17.97	79.85	259
14	74	0.0053	17.61	85.91	284
14	76	0.0074	16.67	97.87	341
14	77	0.0118	16.11	103.64	374
14	78	0.0132	15.52	109.20	408
14	81	0.0164	13.59	124.24	529
14	83	0.0211	12.27	132.76	625
14	84	0.0190	11.62	136.57	678
14	85	0.0177	10.98	140.09	736
14	86	0.0103	10.36	143.35	797
14	96	0.0631	5.30	164.73	1783
14	97	0.1460	4.92	166.06	1936
14	100	0.1210	3.88	169.45	2504
14	103	0.2000	3.01	172.11	3278
14	104	0.2783	2.76	172.86	3590
14	109	0.5433	1.72	175.76	5856
14	110	0.7050	1.56	176.20	6472
14	111	0.4893	1.41	176.60	7177
14	112	0.5500	1.27	176.96	7984
14	113	0.5133	1.14	177.28	8911
14	114	0.8800	1.03	177.57	9878
14	115	0.8367	0.92	177.83	11075
14	117	1.7333	0.75	178.26	13618
14	138	1.5933	0.91	178.09	11213
14	150	0.3583	2.01	175.46	5014
14	166	0.1267	3.96	171.96	2490

Table 21 (contd)

Deep Space Station (DSS)	Day of year (DOY)	Average doppler noise, Hz	Sun-Earth-probe angle α , deg	Earth-Sun-probe angle β , deg	Integrated solar intensity (ISI)
42	84	0.0252	11.62	136.57	678
42	88	0.0133	9.18	149.12	935
42	89	0.0108	8.61	151.68	1013
42	90	0.0127	8.07	154.03	1097
42	98	0.0793	4.55	167.28	2109
42	99	0.0823	4.21	168.41	2294
42	100	0.0790	3.88	169.45	2504
42	101	0.1150	3.57	170.41	2737
42	150	0.4283	2.01	175.86	5014
42	154	0.2300	2.47	174.94	4059
43	63	0.0049	16.21	29.90	107
43	65	0.0048	17.37	37.64	126
43	66	0.0052	17.80	41.96	137
43	67	0.0033	18.14	46.59	150
43	69	0.0046	18.49	56.74	179
43	70	0.0051	18.51	62.23	196
43	73	0.0039	17.97	79.85	259
43	80	0.0134	14.24	119.52	486
43	81	0.0148	13.59	124.24	529
43	83	0.0248	12.27	132.76	625
43	84	0.0161	11.62	136.57	678
43	85	0.0157	10.98	140.09	736
43	86	0.0129	10.36	143.35	797
43	96	0.0385	5.30	164.73	1783
44	92	0.0313	7.06	158.19	1287
44	93	0.0387	6.59	160.03	1394
44	94	0.0565	6.14	161.73	1512
44	95	0.0451	5.71	163.29	1641
44	97	0.0893	4.92	166.06	1936
44	103	0.2083	3.01	172.11	3278
62	64	0.0072	16.84	33.62	116
62	65	0.0036	17.37	37.64	126
62	72	0.0032	18.25	73.84	236
62	73	0.0069	17.97	79.85	259
62	76	0.0081	16.67	97.87	341
62	79	0.0230	14.89	114.51	446
62	86	0.0137	10.36	143.35	797
62	93	0.0723	6.59	160.03	1394
62	100	0.0707	3.88	169.45	2504

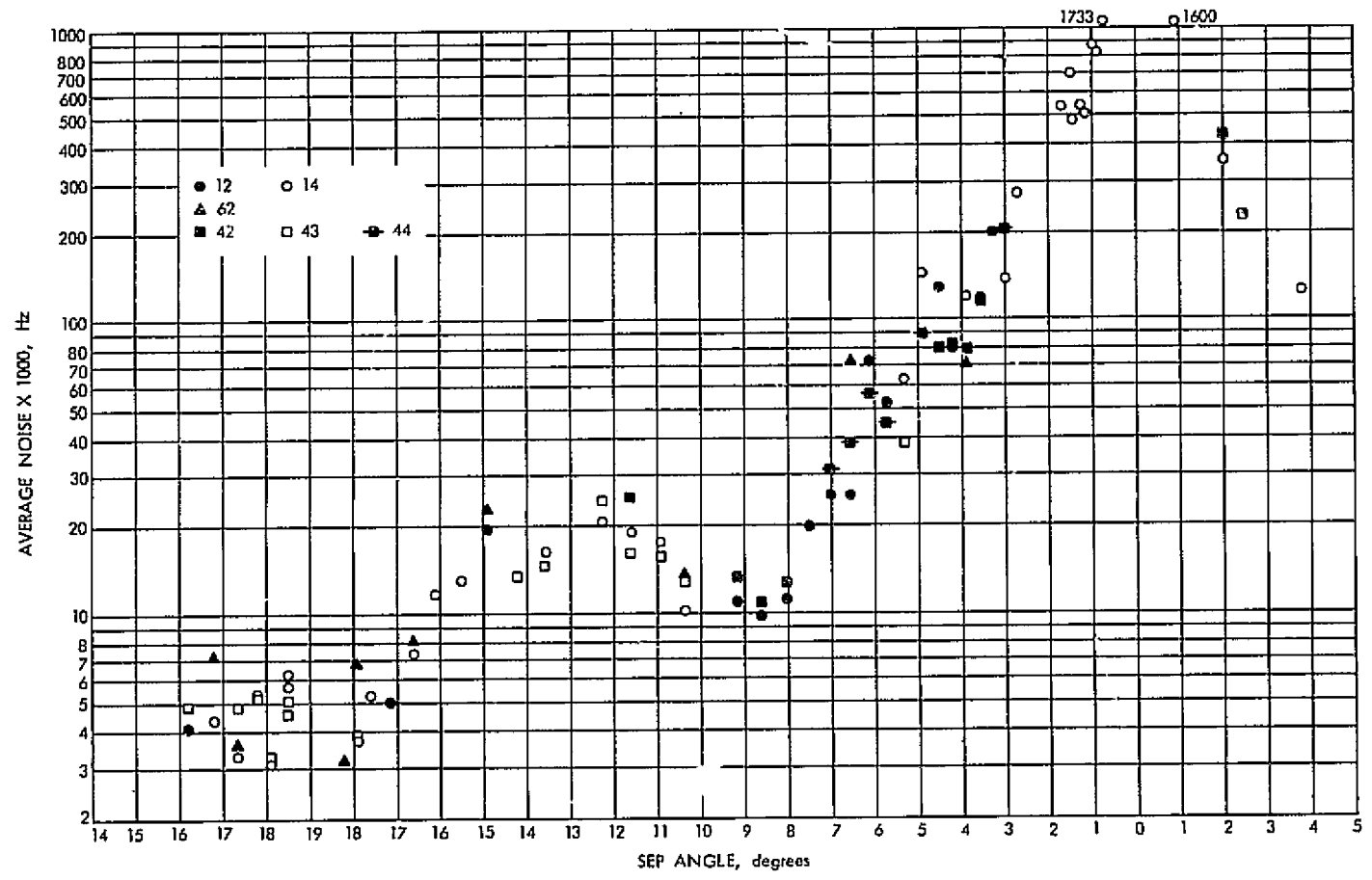

Fig. 19. Helios-1 average noise vs SEP angle

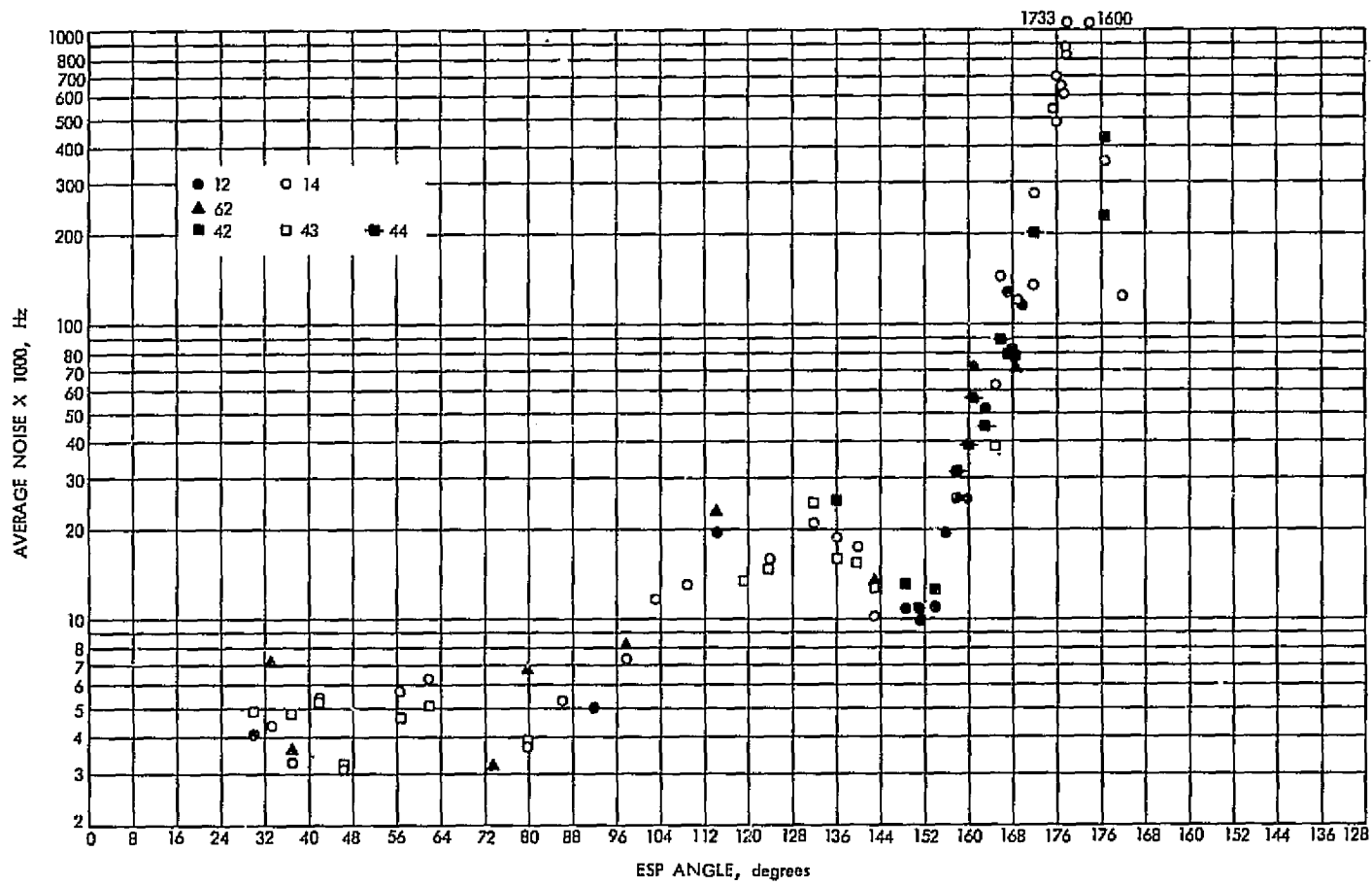

Fig. 20. Helios-1 average noise vs ESP angle

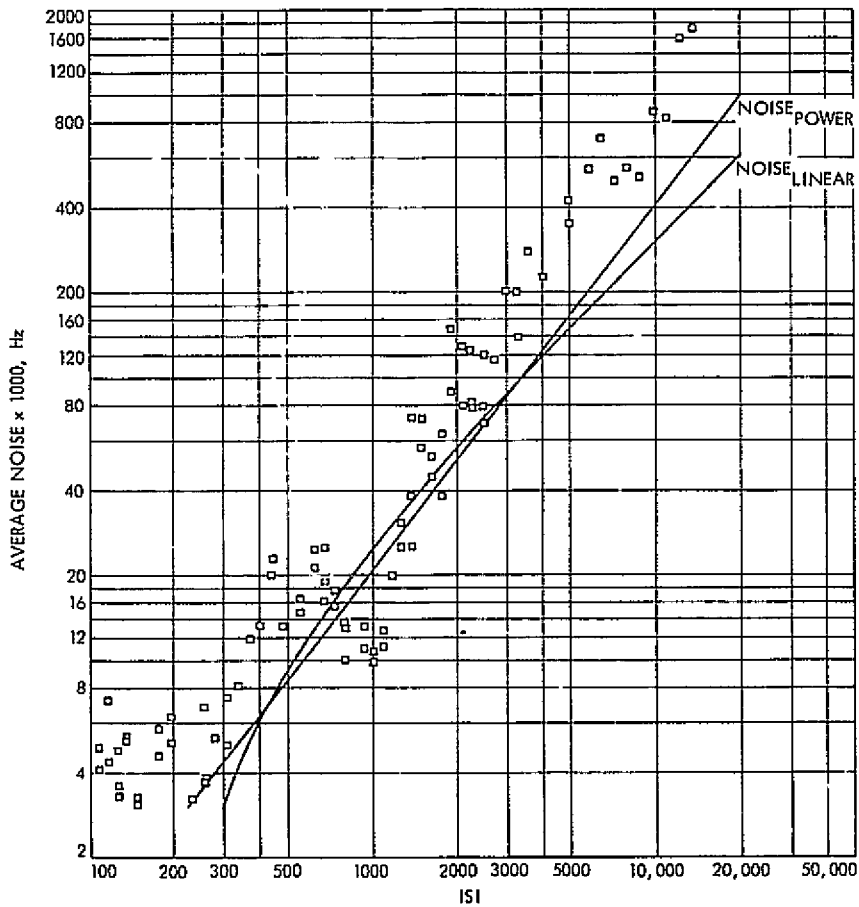

Fig. 21. Helios-1 average noise vs ISI

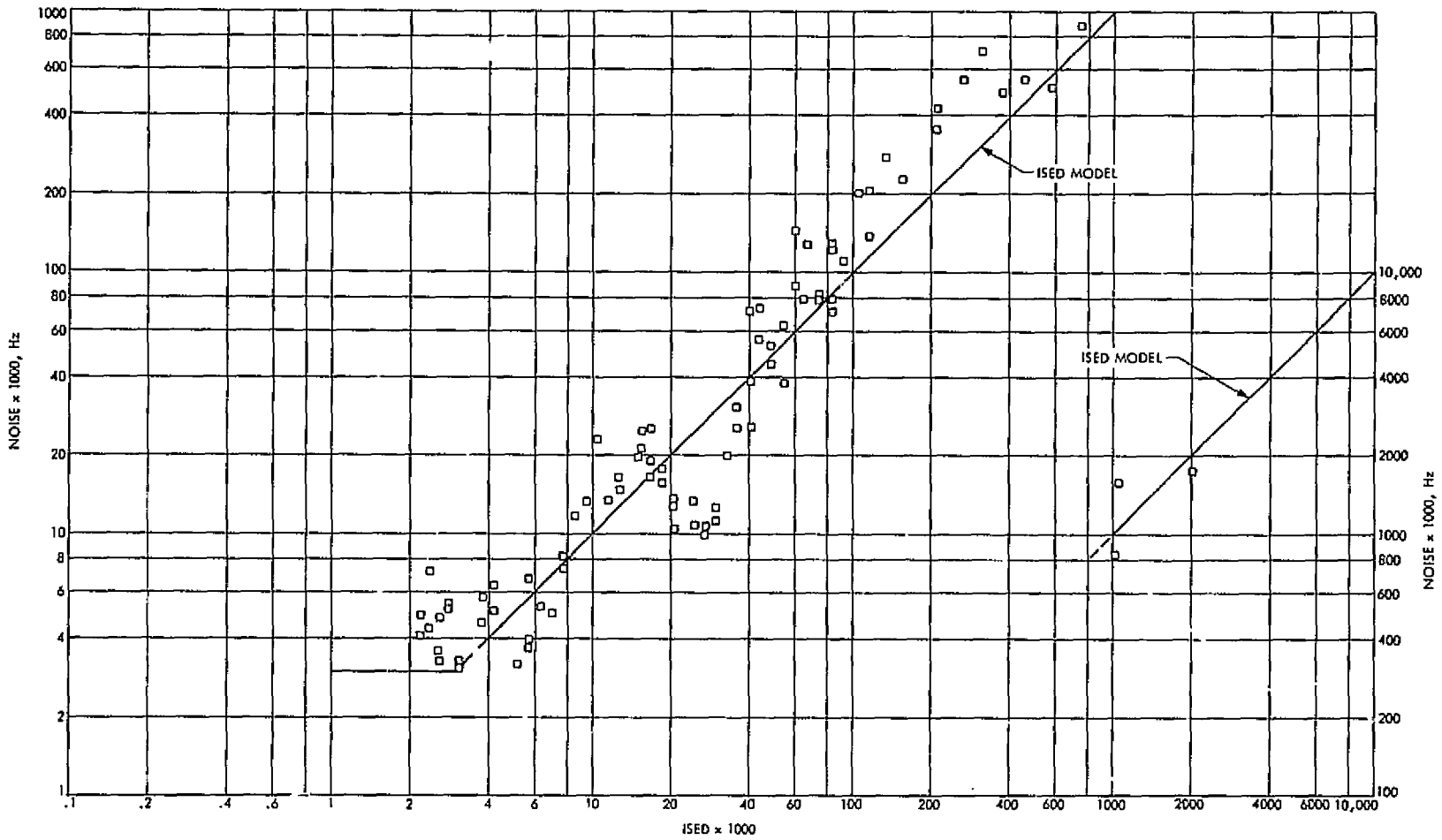

Fig. 22. Helios-1 first 1975 solar conjunction
observed doppler noise vs ISED model

REPRODUCIBILITY OF THE
ORIGINAL PAGE IS POOR

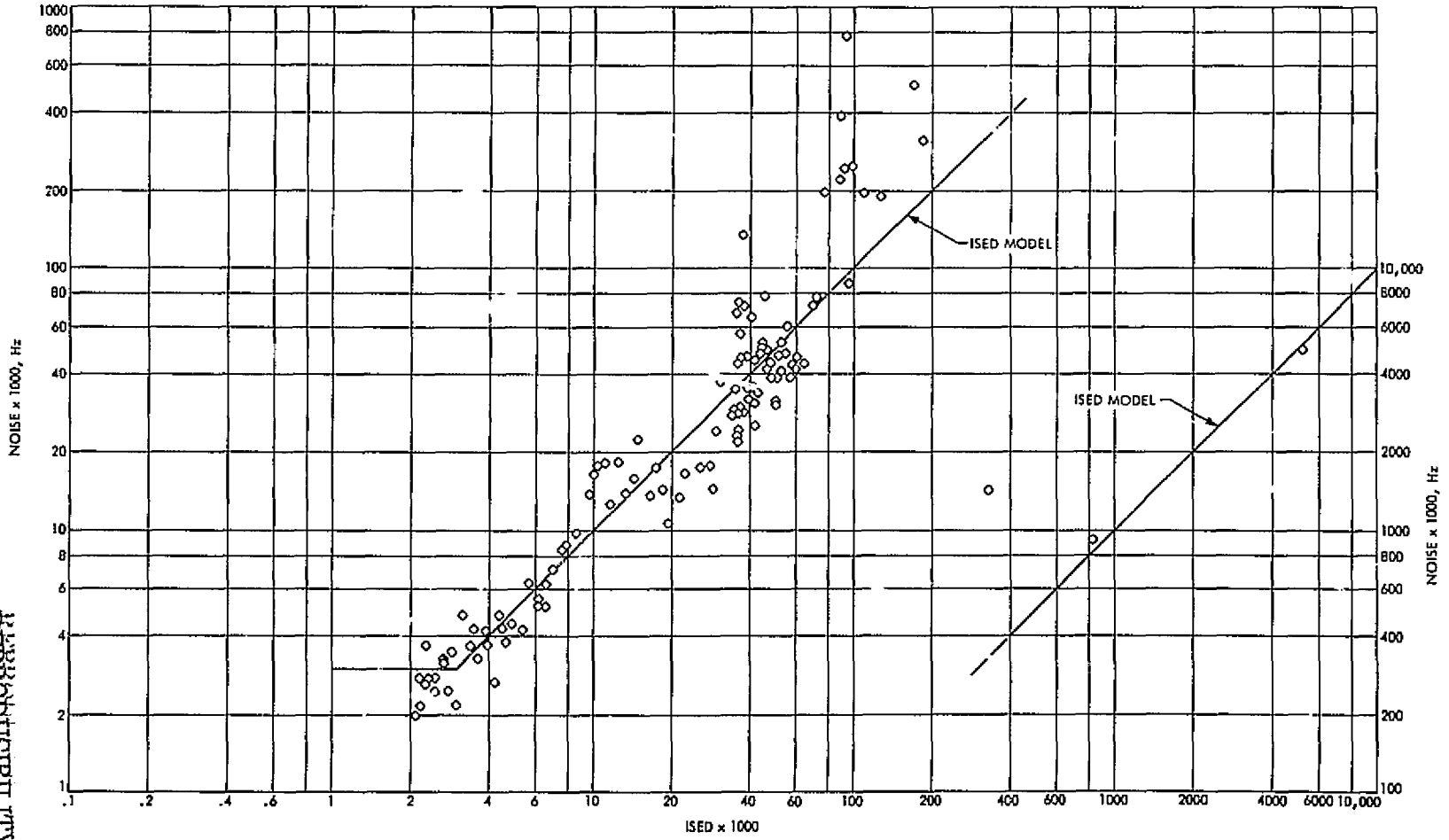

Fig. 23. Helios-1 second 1975 solar conjunction observed doppler noise vs ISED model

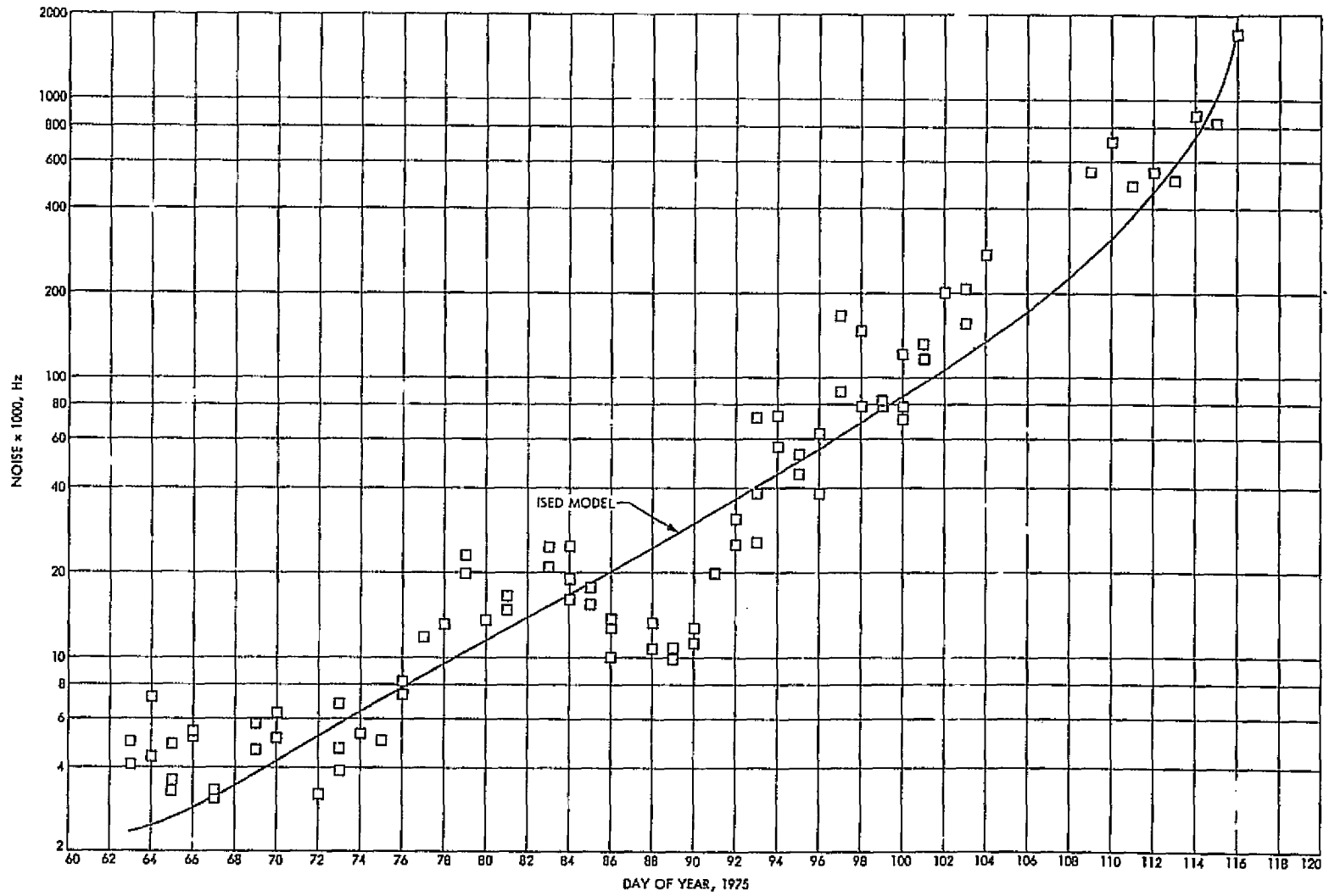

Fig. 24. Helios-1 first 1975 solar conjunction observed doppler noise and ISED model vs day of year

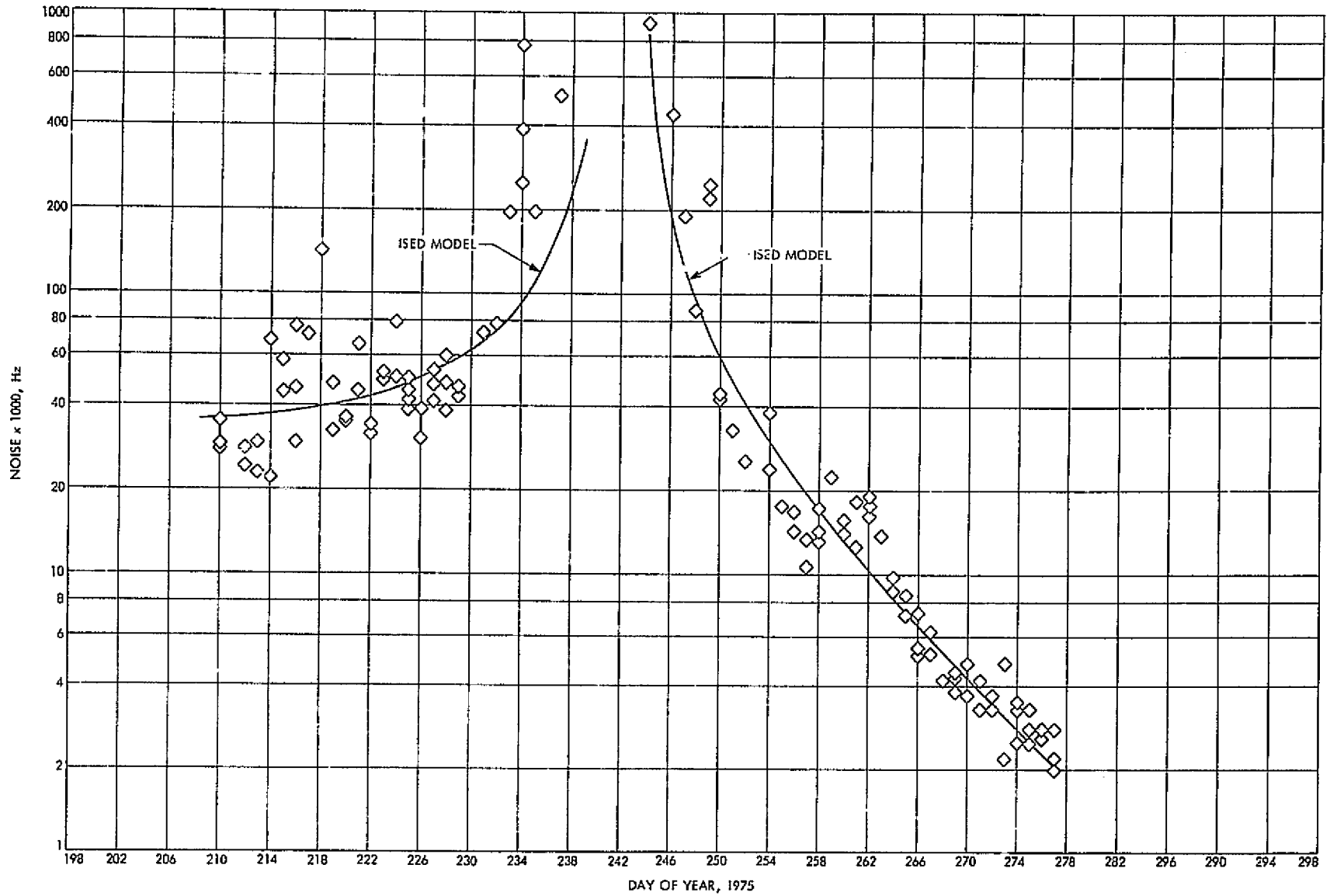

Fig. 25. Helios-1 second 1975 solar conjunction observed doppler noise and ISED model vs day of year

In late August 1975, a special 2-MHz doppler bias capability was implemented throughout the DSN to ensure quality doppler data during the second Helios-1 perihelion. Due to the Sun-Earth-probe geometry during this perihelion, the Earth-received doppler shifted in a negative direction outside the normal operating range of the Tracking System. Selected DSN stations received the modified doppler configuration for operational support from 1 September to 11 October 1975. Additionally, the stations had to compensate for the excessive doppler effects in the uplink and downlink communications signal by switching from the standard S-band channel 21 frequency. The doppler effect resulted in a receive frequency within the channel 22 range, while the transmitter frequency dropped to a channel 20 frequency. This operational mode existed from 3 September to 24 October 1975 and operated flawlessly during this important stage of the mission.

A changeover from the special 2-MHz doppler bias for Helios-1 tracks to the standard 1-MHz bias occurred on 11 October. Almost immediately, Australia DSS 43 and Spain DSS 63 began to show a very large doppler residual. The problem was traced in real-time to the Biased Doppler Detector Module of the Doppler Extractor. When the unit was tested at the Helios 1-MHz biased doppler frequency, a harmonic distortion showed up. Several replacement modules were tried. Some gave good doppler residuals while some did not. It was concluded that operation of the module so near its design specification threshold was marginal and risky.

VII. SPECIAL SUPPORT ACTIVITIES

A. SPACEFLIGHT TRACKING AND DATA NETWORK SUPPORT

During the closing months of 1974, it had become apparent to the NASA Office of Space Science (OSS) that the long-range forecast of tracking requirements for planetary spacecraft far exceeded the capability of the DSN. In a memorandum from OSS to the Office of Tracking and Data Acquisition (OTDA) in January 1975, OSS suggested that OTDA investigate two methods of alleviating the problem: (1) increase staffing at all DSN stations to provide for a full 168 hours of operation per week, and (2) use the co-located STDN stations to provide some relief to the DSN stations.

OTDA was already aware that the DSN was facing an unprecedented support problem during the Viking flight activity from August 1975 through November 1977, and that increasing station staffing would be only a partial solution due to conflicting spacecraft view periods. In addition, OTDA was also aware that in late 1976 major modifications were required by the DSN data systems to support the launch, cruise, and encounter phases of the Mariner Jupiter-Saturn (MJS) 1977 and the Pioneer Venus 1978 missions, and that the Helios-B data requirements called for continuous tracking coverage from launch to first solar conjunction in May 1976.

In a memorandum to the Goddard Space Flight Center (GSFC), OTDA requested that the Spaceflight Tracking and Data Network (STDN) review their workload and capabilities to ascertain what cross support could be provided the DSN. OTDA called for a discussion in March 1975, with representatives from GSFC-STDN and JPL-DSN, on the feasibility of STDN providing analog recording cross support to the DSN. These discussions, which covered equipment and performance differences between the STDN and the DSN, resulted in the decision that the best way to determine the real difference between the two networks was by actual tracking of a spacecraft.

Previous DSN experience (in late 1974) gained in utilizing an STDN station⁷ had indicated an expected performance difference of approximately 4 dB between a 26-meter STDN station with a maser and a DSN 26-meter antenna station. With that difference the STDN stations should be capable of supporting the Helios Project out to a range of approximately 1.73 AU at a data rate of 64 bps (assuming spacecraft operating on high power and high-gain antenna).

1. Analog Recording Tests

a. Madrid STDN-DSN Test. Prior to the agreed upon test, the DSN learned that the STDN stations were replacing their Block III receivers with new Multi-Frequency Receivers (MFRs) which operate at 400 MHz. In order to obtain S-band reception, however, the MFRs were preceded by down converters. This meant that there could be a considerable difference in noise characteristics near threshold that might affect sequential decoding. On 24 May 1975, a

⁷See Volume I, Section V, Subsection D. DSS 44 Implementation for Helios Support, p. 121, of this Technical Memorandum series.

test was conducted to evaluate the performance difference between the Madrid STDN station with the new MFR and DSS 62 with its Block III receiver while tracking the Pioneer 11 spacecraft. However, due to problems with the MFR, the STDN station was unable to lock onto the Pioneer 11 downlink signal, and a second test had to be scheduled. Analysis of the test revealed that the problem probably was in the STDN station's S-band downconverter being in a nonphase-lock mode through the misadjustment of a cavity oscillator.

The second test was conducted on 17 September 1975, and both the Madrid STDN and DSS 62 receivers locked on the Pioneer 11 downlink signal in both 10- and 30-Hz loop bandwidths (single-sided) of the MFR using the maser. This indicated a 5-dB margin using the 10-Hz bandwidth. The STDN received signal level was approximately -157 dBm, as the data supplied by the DSN had predicted. Evaluation of the test data indicated that the MFR performance had a 2-dB higher threshold (i.e., poorer performance) than the DSN Block III receivers. As a result of this evaluation, it was concluded that the STDN stations were capable of supporting both the Helios and Pioneer Projects as long as the received signal levels remained above -162 dBm.

The analog recordings of Pioneer 11 data made at Madrid STDN and DSS 61 were shipped to the STDN (MIL 71) station at Cape Canaveral Air Force Station, where baseline and system noise temperature tests were performed. The STDN (MIL 71) testing configuration is shown in Fig. 26. The results of the MIL 71 baseline tests are shown in Table 22. The results of the STDN MILA system noise temperature tests are shown in Table 23.

The results of these tests indicated the following:

- (1) The near threshold performance of the STDN phase-shift-keying (PSK) Demodulator/Bit Synchronizer was degraded 3 to 4 dB over the DSN Subcarrier Demodulator Assembly (SDA).
- (2) The STDN recorder (FR-1900), utilizing a 2.54-centimeter (1-inch) tape, produced a better quality tape but was incompatible with the DSN recorder (FR-1400), which utilized a 1.27-centimeter (1/2-inch) tape.
- (3) The recorded receiver baseband data could not be recovered from either the DSN or STDN recorders.

On 8 November 1975, another Madrid STDN data acquisition test was conducted -- this time with the Helios-1 spacecraft. This test was designed to evaluate the Madrid STDN ground data system and the MIL 71 capability to provide non-real-time Helios telemetry data through the JPL-Project interface to the German Helios Project. Four specific test objectives were to be met:

- (1) Validate telemetry acquisition at Madrid STDN site at selected Helios spacecraft bit rates.
- (2) Compare real-time system performance and an analog telemetry data tape with the standard parameters being recorded from the multi-function receivers plus the following signals:

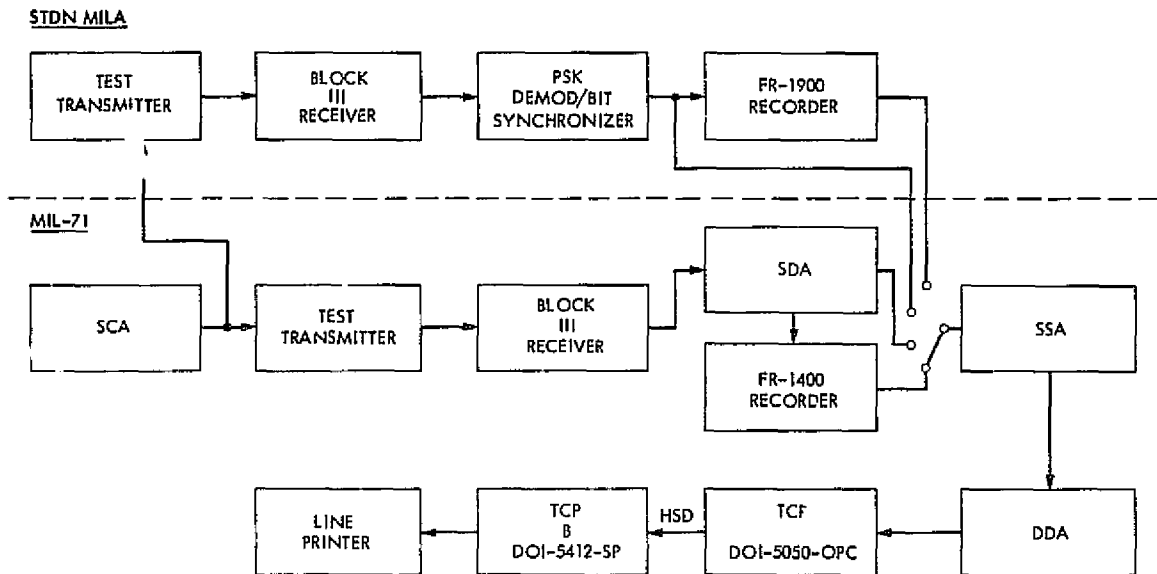

Fig. 26. STDN MILA/MIL 71 block diagram configuration

REPRODUCIBILITY OF THE ORIGINAL PAGE IS POOR

Table 22. MIL 71 baseline test results of Pioneer 11 data from Madrid STDN and DSS 61

Bit rate	ST_b/N_0 , dB	Carrier signal level, dBm	Real-time	Playback (FR-1400)	Symbol Error Rate, %	Erasure rate, %	Signal-to-noise ratio, dB
1024 coded	1.0 ^a	-138.5	X		7.25	0.3	1.45
64 coded	1.0 ^a	-150.5	X		8.77	7.0	1.28
64 coded	4.0	-147.5		X	13.0	36.3	0.30
64 coded	5.0	-146.5		X	12.0	0	0.40
64 coded	6.0	-145.5		X	10.7	0	0.40
64 coded	7.0	-143.5		X	7.8	0	---

^aBased on system noise temperature of 750 K.

Table 23. STDN (MIL 71) system noise temperature test results of
of Pioneer data from Madrid STDN and DSS 61

Bit rate	ST_b/N_0 , dB	Carrier signal level, dBm	Real-time	Playback (FR-1900)	Symbol Error Rate, %	Erasure rate, %	Signal-to- noise ratio, dB
1028 coded	1 ^a	-143.1	X		---	---	
1028 coded	5	-139	X		3.45	3.12	
1028 coded	5	-139		X	3.51	3.02	
1024 coded	8	-136		X	0.65	0	
64 coded	1 ^b	-157	X		---	---	
64 coded	4	-154	X		1.84	14.2	24.5
64 coded	4	-154		X	2.0	11.4	24.5

^aBased on a system noise temperature of 295 K.

^bBased on a system noise temperature of 164 K.

- (a) 2 PSK demodulator outputs - 150 and 300 kHz.
 - (b) 2 PSK/bit synchronizer outputs - 150 and 300 kHz.
 - (c) Provided the FR-1900 recorder tracks are available, record the 1.27-centimeter (1/2-inch) tape, the multi-function receiver outputs of the 150- and 300-kHz telemetry bandpass filters.
- (3) Evaluate ability to process analog data at MIL 71 and produce a Digital Original Data Record (DODR).
 - (4) Determine the difference between Helios telemetry performance curves at a DSN 26-meter station and a STDN 26-meter station.

For this test DSS 61 provided the 26-meter STDN station with spacecraft bit rate changes times via interstation voice communications. During the test DSS 61 also recorded a standard analog tape to be shipped along with the STDN analog tape to STDN (MIL 71) for processing into a Digital Original Data Record, which was later transmitted to the MCCC at JPL, via high-speed data lines, where both the DSN and STDN performances were analyzed and compared to determine a baseline for STDN Helios support.

To initiate the test DSS 61 acquired the Helios-1 spacecraft at a bit rate of 8 bps, and both DSS 61 and the Madrid STDN recorded the data for one hour. The planned bit rate changes for this test were as follows:

Bit rate	Record time
8 bps/16 sps (STDN bit sync setting)	1 hour
1024 bps/2048 sps	1 hour
512 bps/1024 sps	30 minutes
256 bps/512 sps	30 minutes
128 bps/256 sps	30 minutes
64 bps/128 sps	30 minutes
32 bps/64 sps	1 hour
16 bps/32 sps	1 hour
32 bps/64 sps	1 hour
1024 bps/2048 sps	1 hour
8 bps/16 sps	Till loss of signal

Prior to the acquisition of the telemetry downlink, the DSN informed the operating personnel at the Madrid STDN that the round-trip light-time (RTL), the communication time to and from the spacecraft, would be 3 minutes 26 seconds and, therefore, should not expect an immediate spacecraft response to DSN commands for a bit rate change.

The DSN and STDN tapes were shipped to MIL 71 for processing and evaluation, and the results are shown in Table 24. During this test DSS 61 was also processing and transmitting the data in real-time to MCCC for comparison with the playback of the analog data tape.

b. Configurations. Concurrently with the Madrid STDN-DSN analog recording tests, the DSN was investigating four possible configurations:

- (a) An analog baseband recording at the STDN 26-meter stations, which would be shipped to the STDN MIL 71 station for processing into a Digital Original Data Record. The DODR could then be recalled via HSDL from the STDN (MIL 71) station on a scheduled basis to the Mission Computing and Control Center at JPL for data record production. The practicality of this approach depended upon the total dB losses through the system and represented no new implementation cost for achieving a record-only support of telemetry for deep space missions.
- (b) An analog symbol-stream recording, which would undergo the same chain of processing as described in configuration (a), and which represented no additional implementation cost, -- being merely a matter of which of these two configurations would have the better performance.
- (c) A digital recording of the soft symbols at the STDN stations with shipment to STDN (MIL 71) for processing. This approach would require some new software at the STDN stations and new software for the DSN equipment which did not currently interface with digital symbol recording. This configuration was under consideration because of concern over dB losses associated with analog recording and playback. There was also a feeling that the baseband losses could be held small enough to be of the same order as losses due to the STDN symbol synchronizer.
- (d) A real-time telemetry configuration for Helios which would involve STDN implementing a sequential decoder and associated formatting software and which would also require some implementation at MCCC depending upon whether the STDN would be capable of outputting a standard DSN format and associated high-speed data line rate. However, if GSFC was unable to output DSN format and line rates, then a 7200-bps GCF interface and associated formatting software would have to be implemented to get the data into MCCC.

Table 24. Madrid STDN/DSS 61 data acquisition test results (8 November 1975)

Bit rate, bps	Symbol rate, sps	DSS 61		STDN (MAD)	
		Real-time SNR, dB	Playback SNR, dB	Playback SNR (FR-1400), dB	Playback SNR (FR-1400), dB
1024	2048	11.3	10.0	3.3	2.0
512	1024	14.9	12.3	6.9-7.4	2.5
256	512	18.0	14.8	10.0	8.2
128	256	21.0	17.2	12.4	4.5
64	128	23.5	20.0	14.5	12.7
32	64	25.0	21.5	15.5	varying
16	32	26.3	21.9	14.0	varying
8	16	27.2	23.9	14.0	varying

Of the four, configuration (a) looked the most desirable; however, the total estimated dB loss ranged from 9.5 down to 4.5 dB as shown below:

	<u>Adverse</u>	<u>Favorable</u>
Polarization loss	-0.5 dB	-0.5 dB
Multi-Frequency Receiver	-2.0 dB	-0.0 dB
System temperature	-4.0 dB	-3.0 dB
Record-playback	<u>-3.0 dB</u>	<u>-1.0 dB</u>
Total	-9.5 dB	-4.5 dB

The system temperature number was based on the experience with the Honeysuckle station and included all losses prior to the receiver. The record-playback losses were the sum of all losses after the receiver. All indications were that Helios support could be possible at two or three bit rates lower than a standard DSN station.

It should be pointed out that a configuration utilizing a microwave link to a DSN station was not considered at this time because of the heavy demands made on DSN equipment by the Viking mission so that finding a free DSN telemetry stream in real-time would greatly reduce the utility of the STDN cross support.

The U. S. Project Manager, after reviewing the DSN study on STDN cross support, agreed that configuration (a) and its assumptions were viable for Helios support. In addition, because of the resource competition between the Helios, Pioneer, and Viking Projects, it was imperative that NASA increase its planetary data reception capability, and the potential use of the STDN for DSN cross support of Helios was only the first step to this end. It remained only to conduct a test in early October in order to verify some of the DSN assumptions. Based on the results obtained from the October-November testing, described in the following paragraphs, a final decision was made in December on an STDN/analog record-only configuration whereby analog symbol recordings (configuration b) would be made at both the Goldstone and Madrid STDN 26-meter stations.

Meanwhile, as the DSN was implementing a record-only STDN configuration to be operational by 15 January 1976, a request was received from the U. S. Project Manager to investigate a means of improving STDN performance and providing a real-time interface with the Helios Project.

c. STDN-DSN Data Acquisition Test. During the first week of October 1975, the DSN had established a test plan to evaluate the use of the STDN ground data system at Goldstone and the MIL 71 to provide nonreal-time Helios telemetry data through the JPL-Project interface to the German Helios Project. Four specific test objectives were to be met:

- (1) Validate telemetry acquisition at Goldstone STDN site at selected Helios spacecraft bit rates.
- (2) Compare real-time system performance and an analog telemetry data tape with the standard parameters being recorded plus the following signals:
 - (a) PSK demodulator output.
 - (b) PSK/bit synchronizer output.
 - (c) Provided open recorder tracks where available, record receiver (both 60 and 420 kHz) telemetry bandpass filter output. A 420-kHz filter module to be supplied by JPL.
- (3) Evaluate ability to process analog data at MIL 71 and produce a DODR.
- (4) Determine the difference between Helios telemetry performance curves at a DSN 26-meter station and an STDN 26-meter station.

For this test DSS 12 provided the 26-meter Goldstone STDN station with spacecraft bit rate change times via interstation voice/communications. During the test, DSS 12 also recorded a standard analog tape to be shipped along with the Goldstone STDN analog tape to STDN (MIL 71) for processing into a Digital Original Data Record, which was later transmitted to the MCCC at JPL (via high-speed data lines), where both the DSN and STDN performances were analyzed and compared during real-time and nonreal-time operations to determine a baseline for STDN Helios support.

To initiate the test DSS 61 commanded the Helios-1 spacecraft to a bit rate of 256 bps prior to a two-way handover to DSS 12. Both DSS 12 and the Goldstone STDN station recorded the 256-bps data for a period of one hour. At the end of 1 hour of recording, DSS 12 commanded the bit rate to 8 bps and recorded for 45 minutes. The operations personnel at the Goldstone STDN station were informed beforehand that the round-trip light-time (RTLTL), the communications time to and from the spacecraft, would be 7 minutes 51 seconds and, therefore, should not expect an immediate spacecraft response to commands.

The planned bit rate changes for this test were:

Rate, bps	Recording time, min	Modulation index, deg
8	45	42
16	45	42
32	45	42
64	45	54.6
128	60	54.6
256	60	54.6
512 ⁸	30	54.6
256	Till loss of signal	54.6

The test was conducted on 16 October 1975 with only approximately 85% of the test objectives being met due to a STDN maser failure just prior to acquiring the spacecraft downlink signal, and the fact that the Helios Project Operations (Germany) rearranged the planned bit rate sequence to make them synchronous with the occurrence of telemetry main frames. The maser failure forced the STDN station to conduct the test utilizing a cooled parametric amplifier, which lowered the station's performance level, but it did provide an opportunity to test a backup configuration which had not been considered as desirable a mode.

A second test was conducted on 21 October with both the STDN and DSN stations meeting the test objectives. The Helios Project Operations (Germany) supplied bit rate change sequence was executed, but the timing errors resulting from main frame synchronous bit rate changes again resulted in large losses of telemetry data. Neither station obtained 32-bps data during the test. This was probably the result of the 32-bps data rate not being on long enough for the stations to achieve an adequate telemetry lock. Failing to obtain data at 32 bps, the stations performed extensive search before DSS 12 achieved a telemetry lock at 16 bps.

During both of these tests, DSS 12 was processing and transmitting the data to the MCCC in real-time for comparison with the playback of the analog data tape. The analog recordings from the Goldstone STDN and DSS 12 tests conducted on 16 and 21 October 1975 were shipped to STDN (MIL 71)

⁸The 512-bps data rate was expected to be beyond the STDN threshold.

and processed into a Digital Original Data Record (DODR) recording. On 28 October 1975, the DODR recordings were played back to MCCC at JPL to produce a Master Data Record (MDR). Playback of the digitized data from both tests required only one hour and was accomplished without problems.

MCCC conducted a comparison test of the Goldstone STDN data against the DSS 12 data, and, while certain differences were expected in quality and completeness, there were a couple of unexplained differences. One was the existence of a time tag offset between the STDN data and that of the DSS 12 data. The following time tag differences were noted on the data from the 21 October test:

Bit rate, bps	Time difference, ms
256	218
128	256
64	120
32	No data
16	-860 to 140
8	No data

In addition there were instances where high-speed data blocks were repeated causing repeating data within the data record.

MDR data were evaluated by comparing the good data received to the total data obtainable, as a function of bit rate. Unfortunately, only a relatively small number of frames were received at the lower bit rates. A summary of the MCCC comparison test results are contained in Table 25.

An evaluation was also made at STDN (MIL 71) of the DODRs, and a summary is contained in Table 26.

2. Real-Time STDN Cross Support

In November 1975, while implementing a telemetry record-only (no tracking or command capability) STDN configuration, the DSN was also investigating the possibility of utilizing the STDN 26-meter stations to provide real-time support equivalent to that of DSN stations. Due to the competition between the deep space missions and the heavy demands placed on the DSN for planetary mission support, it was imperative that every effort be made to increase the real-time data reception capability of the STDN stations in order to provide Helios cross support during the time period of the Viking orbital and lander operations in mid-1976.

Table 25. MDR comparison test results

Bit rate, bps	DSS 12 SDR	STDN 4-block/second replay SDR	STDN 2-block/second replay SDR	MDR ^a
256	406 GF ^b	186 GF	None received	146 GF
	414 PF ^c	380 PF		378 PF
	3 DF ^d	75 DF		
	98.07%	48.75%		39.80%
128 ^e	342 GF	318 GF	310 GF	312 GF
	347 PF	341 PF	313 PF	342 PF
	3 DF	7 DF	4 DF	
	98.56%	93.26%	99.04%	91.23%
64	205 GF	95 GF	97 GF	93 GF
	210 PF	97 PF	97 PF	95 PF
	4 DF	2 DF	0 DF	
	97.62%	97.94%	100%	97.89%
32	No data	No data	No data	No data
16	36 GF	29 GF	38 GF	23 GF
	38 PF	33 PF	39 PF	33 PF
	2 DF	2 DF	0 DF	
	94.74%	87.88%	97.43%	69.70%
8	18 GF	No data	No data	No data
	33 PF			
	6 DF			
	54.55%			

REPRODUCIBILITY OF THE
ORIGINAL PAGE IS POOR

^aMDR does not contain deleted frames.

^dDF = data frame deleted by TCP, but transmitted to MCCC.

^bGF = good frames

^e16 repeating frames not included in tally.

^cPF = possible frames.

Table 26. DODR comparison test results

Test date	Bit rate, bps	Symbol rate, sps	DSS 12 real-time SNR, dB	Playback SNR, dB	STDN (GDS) playback SNR, dB
10/16/75	128	256	18	12.0	5--6
	64	128	21	13.0	9
	16	32	24	15.0	14
	8	16	24	14.0	15.5
10/21/76	512	1024	11		No usable data
	256	512	15		6.0--6.5
	128	256	16		9.0--9.5
	64	128	21		10.5--11.0
	16	32	22.6		16.0
	8	16	---		19.0

From November 1975 to February 1976, numerous studies were made and configurations proposed; however, due to the DSN Helios-B prelaunch and launch operations and the Viking operations, these proposed configurations could not be verified.

The DSN Manager for Helios requested that a feasibility study be conducted regarding the utilization of a microwave link at Goldstone to provide STDN real-time telemetry cross support for Helios. This study was completed in late March 1976. It suggested six alternative methods ranging from a simple temporary coaxial cable installation to a full-duplex microwave link configuration to interconnect the STDN and DSN facilities at Goldstone.

The microwave configuration appeared the most practical, and arrangements were made for an engineering test to be conducted at the Goldstone Deep Space Communications Complex (DSCC). However, because the Goldstone intersite microwave link used to support Apollo had been removed, the first Helios engineering tests were conducted in Spain between Madrid STDN and DSS 62. Meanwhile, efforts to install a temporary coaxial cable 1860 meters (6100 feet) across the desert mountains (between the STDN collimation tower and the microwave antenna at the Goldstone Radar Site (Fig. 27)) to restore the Goldstone STDN-DSN microwave link were started.

The first engineering test of real-time telemetry was successfully performed at Madrid on 21 April 1976. After establishing the internetwork microwave link configuration and adjusting levels, a 32.768-kHz subcarrier modulated with simulated Helios data was sent from DSS 62 to Madrid STDN to modulate their test transmitter and thence injected into the STDN receiver. The STDN receiver baseband output signal was returned via the internetwork microwave link and successfully processed at DSS 62 in their Telemetry and Command Data (TCD) handling equipment. This was followed on 22 April by a test that provided live Helios-1 spacecraft telemetry from Madrid STDN via the internetwork microwave link for simultaneous processing and comparison with DSS 62 telemetry data. The signal-to-noise ratio (SNR) difference was a minus 8.3 dB for the STDN telemetry.

Before another real-time test could be conducted, the Helios Project management terminated the STDN cross support in the analog record-only mode, during a Helios Operations Status Review meeting held at JPL on 4 and 5 May 1976. The overriding reason for this decision was an announcement that the German Telecommand station at Weilheim would be modified in the fall of 1976 to include a telemetry data receiving capability. This station would be dedicated to Helios support. The additional telemetry coverage offered by a dedicated German station, coupled with the capability to store data aboard the spacecraft for subsequent dump during a later tracking period, made the practicality of a "record-only mode" (with its attendant losses and built-in time lag) questionable. Project management decided, however, to continue engineering tests to evaluate the use of a microwave link between STDN and DSN stations for real-time telemetry processing and commanding from the Goldstone longitude.

The success of the Madrid STDN-DSN real-time telemetry engineering test led to a similar test of command performance. On 27 May, the stations were configured so that the DSS 62 Command Modulator Assembly (CMA) would modulate the Madrid STDN station's uplink carrier while the Helios downlink

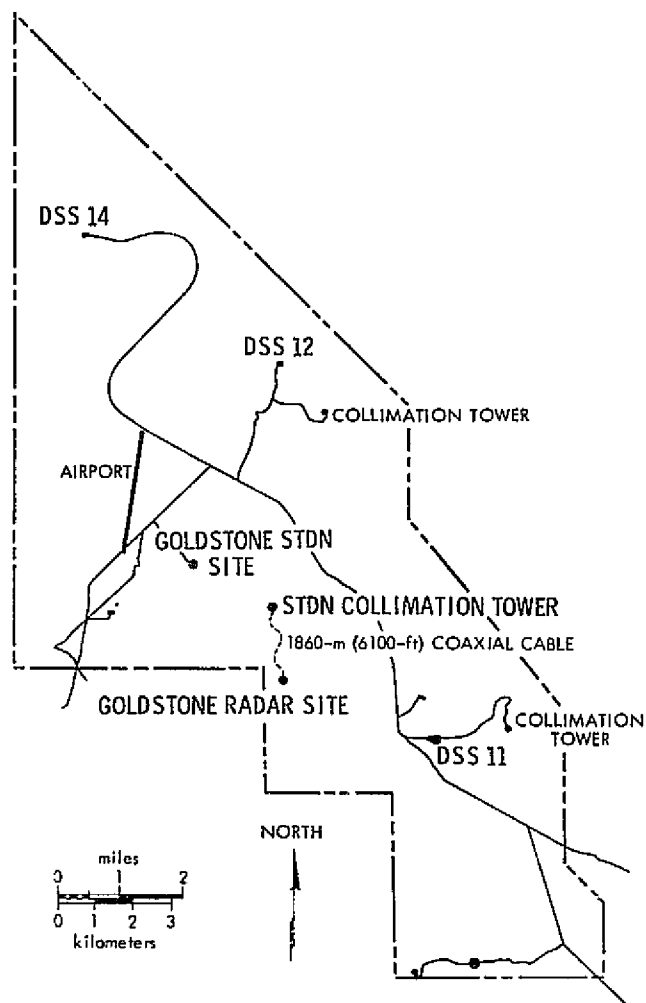

Fig. 27. DSN Goldstone Deep Space Communications Complex

telemetry was received and processed by DSS 62 only. The Helios-1 spacecraft commands were generated, executed, and monitored from the German Space and Operations Center (GSOC). Twenty-eight commands were successfully sent to the Helios-1 spacecraft via the Madrid STDN transmitter.

By 18 May 1976, the Goldstone STDN-DSN combined coaxial line and microwave link had been established one-way (STDN to DSN). With the Madrid engineering test as a model, a real-time telemetry engineering test was performed on 3 June 1976. The Goldstone STDN, using a Block III receiver, received the Helios-1 telemetry subcarrier and forwarded this to the DSS 12 TCD. Simultaneously, DSS 12 tracked Helios-1. The STDN telemetry performance was now only 4.5 dB below the DSN, due to improvements in the STDN station configuration.

Concurrently with the foregoing activity, Helios-2 completed its primary mission (Mission Phase II) as the spacecraft entered its first superior conjunction and the beginning of Mission Phase III. The status of the STDN real-time cross support for the Helios-2 second perihelion was, therefore, uncertain and would have to wait until early September 1976 (second perihelion) for a decision from the Joint U.S. and German Helios Project Managers. A discussion of STDN cross support in the real-time mode will continue in Volume III of this report series.

B. RECEIVE CAPABILITY REQUIRED BY GERMAN COMMAND STATION

The German deep space network for Helios consisted of one telecommand station (30-meter antenna) located at Weilheim and one receiving station (the Max Planck 100-meter antenna) at Effelsberg (Fig. 28). While the Weilheim station could provide continuous Helios support, the Effelsberg station could only provide partial support due to its commitments to radio astronomy. Thus, when the Effelsberg station was not supporting the Helios Project, the Helios Project had command capability but no receive capability. Even when Effelsberg was supporting the Helios Project, its prime task was that of receiving telemetry data from Helios-2 during the latter's primary mission phase, as it had done for Helios-1. In an effort to improve the receiving capability of the German network, NASA Headquarters suggested adding DSN receiving equipments to the Weilheim station so that the Project could receive Helios-1 data at Weilheim while receiving Helios-2 data at the Effelsberg station during 1976-1977.

In February 1975, NASA Headquarters inquired if the DSN had any spare receiving equipment that could be loaned to the German Project. An investigation was conducted by the DSN and revealed that there was one Block II maser available for loan to the German network that was identical in design and completeness as the three on loan from NASA, two of which were operating at the German Effelsberg station. An S-band diplexer could also be made available, along with technical assistance -- if requested.

At the Eleventh HJWGM (20-23 May 1975), a detailed discussion was held on spare DSN receiving equipment available for loan to the German network to implement a receive capability at Weilheim, as well as DSN engineering support to help with the implementation task required to make the Weilheim station operational. At the close of the Eleventh HJWGM, the German Project Office stated that, due to the high cost involved in the antenna modification at Weilheim, a decision had been reached not to accept the surplus receiving



Fig. 28. German deep space network locations

equipment offered by NASA-DSN. At this point both the German and U.S. Project Managers pointed out to all participants that it was the intention of the Max Planck Institute to discontinue 100-meter station support of the Helios Project in mid-September 1976. Without the 100-meter Effelsberg station for telemetry receiving, the usefulness of the Weilheim command station alone was very questionable.

Detail studies and discussions continued for months between JPL, GSFC, and the German Deutsche Forschungs-und Versuchsanstalt fuer Luft-und Raumfahrt, ev (DFVLR). In September 1975, the Helios Project Manager at the NASA-Goddard Space Flight Center (GSFC) received a letter from the German DFVLR Helios Project Manager stating that they had reexamined their decision of May 1975 not to implement a receive capability at Weilheim. As a result of this reexamination, the DFVLR requested that GSFC proceed with the necessary arrangements for the loan of the required equipment to provide the Weilheim command station with a receive capability. The equipment requested by the DFVLR is listed below:

- (1) One maser
- (2) One diplexer⁹
- (3) One transmitter filter⁹
- (4) One receiver filter⁹
- (5) One Receiver/Exciter Subsystem¹⁰
- (6) One PSK-Demodulator Monitor ¹⁰
- (7) Three tape recorders¹⁰

In a letter to the German Helios Project Manager on 19 September 1975, the U.S. Helios Project Manager stated that the surplus NASA equipment was still available and would be loaned to the DFVLR Helios Project Office for the duration of the Helios Project.

In December 1975, NASA shipped from Cape Canaveral and South Africa to the DFVLR the surplus receiving equipment on an indefinite loan basis. This was followed by a DSN shipment in January 1976 of one Block II maser and associated refrigeration equipment, and one S-band 20-kW diplexer assembly with termination and transmit filter.

However, the foregoing equipment was not used. The German Ministry, instead, decided to consolidate its tracking capability by removing the Helios telemetry receiving equipment from the Effelsberg station and reinstalling it at their Weilheim location in time for the Helios-2 first superior conjunction in September 1976. As a result, the NASA-loaned equipments were returned from Germany.

⁹Required for the modification of the Weilheim command station Waveguide System.

¹⁰Required for telemetry receiving.

VIII. CONCLUSIONS

During this one-year reporting period, the DSN successfully supported the Helios Project with 7085 hours of tracking time which included 100% coverage during the prime mission phase of Helios-2.

The Helios-1 superior and inferior conjunctions, along with the Helios-2 inferior conjunction, provided the DSN an opportunity to gather valuable data on the performance of the DSN at very low Sun-Earth-probe (SEP) angles. Additional data will be added to the data base as Helios-2 completes its first superior conjunction in October 1976. The results of this data analysis will be discussed in Volume III of this series.

With the successful completion of its prime mission phase (Mission Phase II) in May 1976, Helios-2 entered an extended mission phase (Mission Phase III), and DSN tracking priority for the Helios Project became equal to that of Pioneers 10 and 11.

Mission objectives and performance were met by both Helios-1 and Helios-2, although both spacecraft experienced some minor anomalies.

Helios-1 has completed two orbits of the Sun and is on its third with Helios-2 following closely behind, but on its first orbit.

GLOSSARY

AFETR	Air Force Eastern Test Range
AGC	automatic gain control
ANT	Antigua Island
AOS	acquisition of signal
ARIA	Advanced Range Instrumentation Aircraft
ASN	Ascension Island
ASU	Automatic Switching Unit
ATC	Associate Test Controller
BDA	Bermuda
BER	bit error rate
bps	bits per second
CCAFS	Cape Canaveral Air Force Station
CIF	Central Instrumentation Facility
CMA	Command Modulator Assembly
CMOS	Chief of Mission Operations Support
COW	Communications Order Wire
CRT	cathode-ray tube
CVT	Configuration Verification Test
DDA	Data Decoder Assembly
DFVLR	Deutsche Forschungs-und Versuchsanstalt fuer Luft-und Raumfahrt, ev
DOD	Department of Defense
DODR	Digital Original Data Record
DRVID	Differenced Range Versus Integrated Doppler
DSCC	Deep Space Communications Complex
EPS	Earth-probe-Sun (angle)
ESP	Earth-Sun-probe (angle)

ETR Eastern Test Range
GBI Grand Bahama Island
GCC German Control Center
GSFC Goddard Space Flight Center
GSOC German Space and Operations Center
GTK Grand Turk Island
HF high frequency
HGA high-gain antenna
HJWGM Helios Joint Working Group Meeting
HSD high-speed data
HSDL high-speed data line
INP inter-net predict
IRV inter-range vector
ISED integrated solar electron density
ISI integrated solar intensity
KSC Kennedy Space Center
LAPP Link Analysis and Prediction Program
LeRC Lewis Research Center
LGA low-gain antenna
LOS loss of signal
MCCC Mission Control and Computing Center
MCT Mission Configuration Test
MDC Mission Director Center
MDR Master Data Record
MECO main engine cutoff
MES main engine start
MFR Multi-Frequency Receiver

MGA medium-gain antenna
 MOC Mission Operations Center
 MSA Mission Support Area
 NASCOM NASA Communications Network
 NAT Network Analysis Team
 NEPN Near-Earth Phase Network
 NETDS Near-Earth Tracking and Data Systems
 NOCT Network Operations Control Team
 NSP NASA Support Plan
 NST Network Support Team
 NTS NASA Test Support
 OCT Operations Control Team
 OD orbit determination
 ODR Original Data Record
 ODT Operational Demonstration Test
 ORT Operational Readiness Test
 OSS Office of Space Science (NASA)
 OTDA Office of Tracking and Data Acquisition
 OVT Operations Verification Test
 PAFB Patrick Air Force Base (Florida)
 P&TG performance and trajectory guidance
 PCM pulse code modulation
 PDT Performance Demonstration Test
 PRA Planetary Ranging Assembly
 PSK Phase-shift-keying
 PSPM Precision Signal Power Measurement
 RCC Range Control Center

REPRODUCIBILITY
 ORIGINAL PAGE IS POOR

RTCS	Real-Time Computing System
RTLTL	round-trip light-time
RUDC	Range User Data Coordinator
SAA	S-Band Acquisition Antenna
S/C	spacecraft
SCA	Simulation Conversion Assembly
SCM	S-Band Cassegrain Monopulse (antenna feed system)
SDA	Subcarrier Demodulator Assembly
SEP	Sun-Earth-probe (angle)
SIRD	Support Instrumentation Requirements Document
SNR	signal-to-noise ratio
SNT	system noise temperature
SOE	sequence of events
SOPM	Standard Orbital Parameter Messages
SOT	Spacecraft Operations Team
sps	symbols per second
SRO	Superintendent of Range Operations
STDN	Spaceflight Tracking and Data Network
TCP	Telemetry and Command Processor
TDA	tracking and data acquisition
TDS	Tracking and Data Systems
TLM	telemetry
TSF	tracking synthesizer frequency
TTY	teletype
TWT	traveling-wave tube
TWTA	traveling-wave tube amplifier
VAN	Vanguard

VSO very stable oscillator

WPAFB Wright-Patterson Air Force Base (Ohio)