

General Disclaimer

One or more of the Following Statements may affect this Document

- This document has been reproduced from the best copy furnished by the organizational source. It is being released in the interest of making available as much information as possible.
- This document may contain data, which exceeds the sheet parameters. It was furnished in this condition by the organizational source and is the best copy available.
- This document may contain tone-on-tone or color graphs, charts and/or pictures, which have been reproduced in black and white.
- This document is paginated as submitted by the original source.
- Portions of this document are not fully legible due to the historical nature of some of the material. However, it is the best reproduction available from the original submission.

NATIONAL AERONAUTICS AND SPACE ADMINISTRATION

Technical Memorandum 33-783

Volume I

*Tracking and Data System Support for the
Viking 1975 Mission to Mars*

Prelaunch Planning, Implementation, and Testing

(NASA-CR-149456) TRACKING AND DATA SYSTEM SUPPORT FOR THE VIKING 1975 MISSION TO MARS. N77-16104
VOLUME 1: PRELAUNCH PLANNING, IMPLEMENTATION, AND TESTING (Jet Propulsion Lab.) 215 p HC A10/MF A01 CSCL 17B G3/17 13276
Uncias



JET PROPULSION LABORATORY
CALIFORNIA INSTITUTE OF TECHNOLOGY
PASADENA, CALIFORNIA

January 15, 1977

NATIONAL AERONAUTICS AND SPACE ADMINISTRATION

Technical Memorandum 33-783

Volume I

*Tracking and Data System Support for the
Viking 1975 Mission to Mars*

Prelaunch Planning, Implementation, and Testing

D. J. Mudgway

M. R. Traxler

JET PROPULSION LABORATORY
CALIFORNIA INSTITUTE OF TECHNOLOGY
PASADENA, CALIFORNIA

January 1, 1977

PREFACE

This report describes Tracking and Data System support for the Viking 1975 Mission to Mars in four volumes corresponding to the four major phases of the Project.

This, the first volume, presents organization, planning, implementation, and test activities from inception of the Project in 1969 to the 1975 launch operations. Cruise and orbital phase activities of the two Viking spacecraft from launch to touchdown of the first Lander are described in the second volume. The third volume discusses the support for second Lander touchdown and planetary surface and orbital operations of both orbiters and both landers. The fourth volume will report on extended mission operations beyond the nominal end of the primary mission.

The Tracking and Data System activities discussed in this report were managed and/or carried out by the Jet Propulsion Laboratory, California Institute of Technology, Pasadena, California, under Contract No. NAS7-100, sponsored by the National Aeronautics and Space Administration.

N.A. Renzetti
Tracking and Data System
Manager

ACKNOWLEDGMENT

The authors acknowledge the assistance of M.E. Binkley and A.C. Belcher of the NASA Office of Tracking and Data Acquisition, as well as personnel of Air Force Eastern Test Range, Goddard Space Flight Center's Spaceflight Tracking and Data Network and the National Aeronautics and Space Administration Communications Network, and the John F. Kennedy Space Center in preparing this document. Thanks are also extended for the helpful efforts of many persons from the Jet Propulsion Laboratory.

CONTENTS

PART A. PLANNING, ORGANIZATION, AND MANAGEMENT

I.	Introduction	3
II.	The Viking Project	7
	A. Concept	7
	B. Objectives and Mission Summary	7
	C. Functional Organization	10
	D. Requirements for Tracking and Data System Support.	19
	1. General	19
	2. Near-Earth	19
	3. Deep Space Station Support	23
	4. Ground Communications Facility Support	24
	5. Simulation Support	24
	6. Network Operations Control Center	24
	7. Backup Capability	24
	8. Operational Readiness	24
	9. Station Coverage	24
	10. Data Requirements	27
III.	Tracking and Data Acquisition System	40
	A. Institutional	40
	B. Planning	41
	1. Pre-Project Planning	41
	2. Planning the 1973 Mission	42
	3. Planning the 1975 Mission	43
	C. Requirements for Tracking and Data System Support	45
	1. Near-Earth Phase	45

2.	Deep Space Phase	46
3.	Unsupported Requirements	50
D.	Management	55
1.	Schedules	55
2.	Engineering Change	57
3.	Documentation	63
4.	Working Relationships	69

PART B. IMPLEMENTATION, TESTING, AND TRAINING

I.	Introduction	75
II.	Near-Earth Phase Support	76
A.	Configurations, Implementation, Trajectories, Control	76
1.	Station Configurations	76
2.	Station Implementation	77
3.	Prelaunch Configurations of Near-Earth Stations	89
4.	Prelaunch Trajectory Selection	89
5.	Operational Control	97
B.	Testing	101
1.	General	101
2.	Launch Vehicle Telemetry Testing	102
3.	Spacecraft Telemetry Testing	103
4.	Metric Data Testing	107
5.	Support of GDS Testing	107

C.	Flight Operations System Tests	108
1.	Flight Operations and Training Tests	108
2.	Operational Demonstration Tests	108
3.	Operational Readiness Test	109
D.	Final Near-Earth Prelaunch Operations.	109
1.	Launch Readiness Review	109
2.	Project Launch Readiness Reviews	109
3.	Near-Earth Launch Constraints and Launch Hold Criteria	109
4.	Near-Earth Requirements Which Could Not be Met	110
III.	The Deep Space Network	111
A.	Implementation	111
1.	Support Capabilities, Configurations	111
2.	High-Power Transmitter Rationale	126
3.	Technical, Operational Difficulties.	128
B.	Network Operations Training	129
C.	Testing at Compatibility Test Area 21	130
1.	Activity Summary	130
2.	System Integration Tests	131
3.	Design Compatibility Tests	136
4.	Spacecraft Telecommunications Compatibility Tests	137
5.	Conclusions	141

D.	Spaceflight Tracking and Data Network —	.
	Merritt Island Testing	141
1.	General	141
2.	System Integration and Ground Data System Testing	145
3.	Mission Precursor Testing	146
4.	Flight-Article Compatibility Tests	147
5.	Communications and Operations Control Center Support	149
6.	Orbiter, Lander, Spacecraft Radio-Frequency Compatibility Testing	149
E.	Network Testing	157
1.	Concepts of Network Testing	157
2.	Network Test Schedule Changes	160
3.	Mission Configuration Tests	161
4.	Operational Verification Tests	163
F.	Final Prelaunch Operations	166
1.	Launch Readiness Reviews	166
2.	Configuration Control, Freeze	168
3.	Initial Acquisition Strategy	171
4.	Network Testing and Training/Near Launch	174
G.	Launch of Vikings A and B	176
1.	Viking A	176
2.	Viking B	177
3.	Spacecraft Identification	177

References	179
Bibliography	180
APPENDIX. Viking Tracking and Data System	
Chronology of Events	202
TABLES	
1. Viking scientific experiments	17
2. Deep Space Network coverage for flight operations, calendar year 1975	25
3. Deep Space Network coverage for flight operations, calendar year 1976	26
4. Deep Space Network radio metric data support - accuracy	29
5. Viking Orbiter telemetry channels	35
6. Viking Lander telemetry channels	35
7. Tracking and data acquisition stations of the Deep Space Network	54
8. Network readiness summary	61
9. Deep space station capabilities required for Viking planetary support	123
10. Status of Mission Configuration Tests as of July 1, 1975	164
11. Launch and cruise capabilities considered in July reviews	167
12. Viking identification matrix for flight spacecraft . .	178

FIGURES

1.	Viking mission events: launch to landing	8
2.	Launch phase Earth tracks	11
3.	Earth-Mars trajectories 1975 Viking launch.	12
4.	Communication links: two landers, two orbiters	12
5.	Elements of the Viking Project	13
6.	Titan IIIE/Centaur D-IT launch vehicle	14
7.	Viking Orbiter configuration	15
8.	Viking lander	16
9.	Viking Project supporting agencies.	18
10.	Viking launch trajectory	20
11.	Viking near-Earth telemetry coverage	21
12.	Summary of near-Earth Tracking and Data System support requirements by Viking	22
13.	Network support for Viking: coverage for tracking, telemetry, and command; test and training support	23
14.	Station 14 Viking hardware capabilities	37
15.	Standard planetary configuration, Orbiter/Lander Orbiter, Code 30	39
16.	Summary of near-Earth support requirements that could not be provided	47
17.	Ground communications support schedule.	49
18.	Goldstone, California, Deep Space Stations.	51
19.	Deep Space Stations 42, 43, and 44 near Canberra, Australia	52
20.	Deep Space Stations 61, 62, and 63 near Madrid, Spain	53
21.	Extract from Tracking and Data System Schedule, Level 3, for November 1974	56

FIGURES

22.	Extract from Tracking and Data System Schedule, Level 4, for November 1974	58
23.	Extract from Goldstone Station 14 Milestone Schedule for November 1974	59
24.	Engineering change planning for Viking	62
25.	Viking 75 Project documentation tree as of January 1975	65
26.	Launch vehicle telemetry configuration for Viking.	79
27.	Near-Earth telemetry configuration	81
28.	Near-Earth station data transmission configuration	82
29.	Typical Advanced Range Instrumentation Aircraft coverage for Viking Mission A	84
30.	Aircraft support for Project Viking; Centaur mark events main engine start No. 2 and main engine cutoff No. 2 engineering data from Centaur link	86
31.	Viking near-Earth metric data flow	87
32.	Plan for providing Centaur guidance telemetry data to the Navigation Team.	88
33.	Viking Project voice circuits	91
34.	Viking Project data circuits for near-Earth support.	93
35.	Viking Project teletype circuits for near-Earth support	95
36.	Basic near-Earth operational control communications interfaces and simplified data flow	99
37.	Launch vehicle real-time telemetry data flow	104
38.	Deep Space Network/Viking telemetry system baseline functional requirements block diagram	113
39.	Deep Space Network Mark III-75 functional network design: 64-meter stations	115

FIGURES

40.	Deep Space Network Mark III-75 functional network design: 26-meter stations	117
41.	Standard planetary configuration, Orbiter/Lander/Orbiter - Code 30	119
42.	Tracking and Data System Level 3 Schedule as of September 1973	122
43.	Tracking and Data System Level 3 Schedule as of August 1974	125
44.	Tracking and Data System Level 3 Schedule as of July 1975	127
45.	Compatibility Test Area 21 Viking telemetry configuration	132
46.	Compatibility Test Area 21 Viking command configuration	133
47.	Merritt Island Station MIL-71 command configuration for Viking Orbiter and Lander Tests	142
48.	Merritt Island Station MIL-71 telemetry configuration for Viking Orbiter and Lander Capsule mated spacecraft tests	143
49.	Merritt Island Station MIL-71 telemetry configuration for Viking Lander tests	144
50.	Telecommunications compatibility test configuration, January 30, 1975	151
51.	Hangar AO/Merritt Island S-band Differenced Range Versus Integrated Doppler stability	153
52.	Hangar AO/Merritt Island X-band Differenced Range Versus Integrated Doppler stability	153
53.	Three phases of Network activity	158
54.	Mission Configuration Test status for Stations 11 and 14 as of May 15, 1975	162
55.	Mission Configuration Test status for Stations 42, 43, 61, and 63 as of May 15, 1975	163

FIGURES

56.	Viking Project Tracking and Data System Schedule at July 9 review	169
57.	Viking Flight Operations Test Schedule at July 9 review	171
58.	Network configuration control for Viking	173
59.	Initial acquisition strategy (time line)	175

ABSTRACT

This report describes the Tracking and Data Acquisition support for the 1975 Viking Missions to Mars.

In this volume the history of the effort from its inception in late 1968 through the launches of Vikings 1 and 2 from Cape Kennedy in August and September 1975 is given. The Viking mission requirements for tracking and data acquisition support in both the near Earth and deep space phases involved multiple radar tracking and telemetry stations and communications networks of the Air Force Eastern Test Range and the Goddard Spaceflight and Tracking Acquisition Network, together with the global network of tracking stations, communications, and control center of NASA's Deep Space Network and NASA Communications Network. The planning, implementation, testing and management of this vast complex of people and facilities to meet the demands of the 1975 Viking Mars launch opportunity is the subject of this particular volume.

33-783, Vol. I

PART A

PLANNING, ORGANIZATION, AND MANAGEMENT

I. INTRODUCTION

The Tracking and Data System supporting the Viking 1975 Project is the selected collection of Earth-based equipment, software, personnel, and procedures required to transmit commands; acquire, relay, and process science and engineering data; and generate, transmit, and process radio metric data. All of the System's resources - including elements of the Air Force Eastern Test Range of the Department of Defense, Kennedy Space Center, Spaceflight Tracking and Data Network, National Aeronautics and Space Administration Communications, and the Deep Space Network, also a National Aeronautics and Space Administration network - were committed to the support of the Mars mission. Of these resources, the Deep Space Network was to be used continuously throughout the mission as an integral part of the Viking ground data system.

The Deep Space Network, established by the National Aeronautics and Space Administration Office of Tracking and Data Acquisition under the system management and technical direction of the Jet Propulsion Laboratory, is designed for two-way communications with unmanned spacecraft traveling approximately 16,000 km (10,000 mi) from Earth to the farthest planets of our solar system. It has provided tracking and data acquisition support for the following National Aeronautics and Space Administration deep space exploration projects, for which the Laboratory has been responsible for the project management, development of the spacecraft, and conduct of mission operations:

- (1) Ranger
- (2) Surveyor
- (3) Mariner Venus 1962
- (4) Mariner Mars 1964
- (5) Mariner Venus 1967
- (6) Mariner Mars 1969
- (7) Mariner Mars 1971
- (8) Mariner Venus/Mercury 1973

The Network has also provided tracking and data acquisition support for the following projects:

- (1) Lunar Orbiter, for which the Langley Research Center carried out the project management, spacecraft development, and mission operations functions.
- (2) Pioneer, for which the Ames Research Center carried out the project management spacecraft development, and mission operations functions.
- (3) Apollo, for which the Lyndon B. Johnson Space Center was the project center and the Deep Space Network supplemented the Spaceflight Tracking and Data Network, which is managed by the Goddard Space Flight Center.

- (4) Helios, a joint United States/West German project.
- (5) Viking, for which the Langley Research Center provides the project management and Lander spacecraft, and conducts mission operations, and for which the Jet Propulsion Laboratory provides the Orbiter spacecraft.

The National Aeronautics and Space Administration Spaceflight Tracking and Data Network is under the system management and technical direction of the Goddard Space Flight Center. Its function is to support manned and unmanned Earth-orbiting and lunar scientific and advanced technology satellites. In addition, the Network provides support from some of its stations for that part of mission trajectory from lift-off at the launch pad to acquisition of the spacecraft by one or more of the stations of the Deep Space Network. This portion of the trajectory closely approximates the flight paths of the low-altitude Earth orbiting satellites for which the Spaceflight Tracking and Data Network was designed.

Further support during this so-called "near-Earth" phase is provided by ships, aircraft, and tracking stations of the Air Force Eastern Test Range. With the range head at Cape Canaveral, Florida, the downrange tracking stations reach in a southeasterly direction across the Atlantic Ocean to Ascension Island. Suitable deployment of ships and instrumented aircraft extend coverages of all spacecraft launched eastwardly from Florida across South Africa and the Indian Ocean. Responsibility for the deployment of all these resources to provide support in both the near-Earth and deep space phases of a space mission is assigned to the Tracking and Data Acquisition Manager. When properly configured, tested, and scheduled, the sum total of the resources described above are known collectively as the Tracking and Data Acquisition System.

The Viking Project is unique in many respects: as a scientific exploration, it is outstanding in the potential importance of its objectives; as a planetary project, in its technical and organizational complexity and size; and as a user of tracking and data acquisition capabilities, in the scope and depth of its requirements. The Viking Mars 1975 mission, consisting of two composite Orbiter Lander spacecraft was programmed to reach Mars in mid-1976, soft-land on its surface, and begin, as one objective, the search for evidence of life on the red planet. Viking is the first flight project specifically designed to answer this momentous question.

The Project engages major efforts at a number of National Aeronautics and Space Administration Centers, at the Jet Propulsion Laboratory, and by many industrial contractors and subcontractors. The Orbiter and Lander systems were large, complex designs, especially the Lander; the Titan Centaur launch vehicle was a new, powerful, and complex system. Cruise and planetary operations require a sizeable flight operations team made up of specialists in many different disciplines as well as numerous scientists with a variety of interests spanning the entire science community.

Viking Project requirements for tracking and data-acquisition support are substantially greater than previous requirements for Mariner or Pioneer-class missions. A maximum of six telemetry streams (two each from both Orbiters and one Lander or the other) are to be accommodated simultaneously; two Orbiters, or one Orbiter and one Lander, are to be tracked and commanded at any one time. The critical period, encompassing planetary approach and operations, lasts approximately five months. During the early part of this period with one spacecraft at the planet, an extra set of tracking stations is required to deal with the second spacecraft, still in its planetary approach phase. When both spacecraft can be covered by one antenna beamwidth, only two sets of antennas are needed. Thus during the Viking view periods, virtually the entire capability of the Network is engaged by this single Project.

At its inception in the late 1960s, the Viking Project was intended to be launched in the 1973 Mars opportunity, making use of the Mariner 1969 flyby and Mariner 1971 orbiter design and operations experience, and their data on the planet. Viking would complete the Mariner-Mars mission sequence of orderly planetary exploration by soft-landing a package of scientific instruments on the planet's surface. To increase mission reliability and scientific scope, two launches were planned. Precise navigation data would be required to achieve the desired landing accuracies, and large quantities of scientific and engineering data were to be telemetered from the two orbiting and two landing craft.

Preliminary Tracking and Data System planning for Viking was undertaken on this basis. Construction of the 64-meter antenna subnet of the Deep Space Network was just then getting underway after a few years' successful operation of the initial advanced antenna system at station 14, the Mars site at Goldstone, California. A contractor was selected to build and install 64-meter antennas at the overseas sites in Australia and Spain, and these facilities were scheduled to be ready to support the Viking 1973 mission. In addition, during this period other new elements of the Tracking and Data Acquisition System destined for Viking support were being demonstrated, such as high-rate telemetry, high-powered transmitters, and the Differenced Range Versus Integrated Doppler navigation techniques.

At the beginning of 1970, funding considerations created far-reaching changes in the Viking Project and resulted in an alteration of the flight schedule from the 1973 to the 1975 launch opportunity. The revised launch date permitted a more thorough examination of Tracking and Data System support requirements and capabilities, and an increased level of commitment from that possible for a 1973 mission.

In July 1972, the National Aeronautics and Space Administration undertook a change in the interface between the Network and the flight projects. Since January 1, 1964, the Network, in addition to the Deep Space Stations and the Ground Communications Facility, also included the Mission Control and Computing Facility, and provided the equipment in the mission support areas for the conduct of mission operations. The latter facilities were housed in a building at the Jet Propulsion Laboratory known as the Space Flight Operations Facility. The

interface change was to accommodate a hardware interface between the Network operations control functions and the mission control and computing functions. This resulted in the flight project assuming cognizance of the large general-purpose digital computers, which were used for Network processing as well as mission data processing. It also assumed cognizance of all of the equipment in the flight operations facility for display, and communications necessary for the conduct of mission operations. The Network had already undertaken the development of hardware and computer software necessary to carry out its network operations control and monitor functions in separate computers; this development was to be known as the Network Control System. A characteristic of the new interface would be that the Network provided direct data flow to and from the stations via appropriate ground communications equipment to Mission Operations Centers, wherever they may be; this flow consists of metric data, science and engineering telemetry, and Network monitor data useful to the flight project. It would accept command data in a standardized format from the flight project directly into the ground communications equipment for transmission to the station and thence to the spacecraft.

By the end of 1973, the planning phase was essentially complete. Key capabilities and interface documents (including a new system interface document) had been revised and released, the design had matured, and key technical studies were completed. In addition, the subnetwork of 64-meter antennas was operational and the implementation phase had begun. Initial design compatibility testing with breadboard models of the Orbiter and Lander radio system had begun at the Compatibility Test Area 21 at the Jet Propulsion Laboratory at Pasadena, California.

Following these tests, simulated spacecraft data were input to the Compatibility Test Area 21 to verify the design of the ground data link, beginning with radio frequency data from the spacecraft and ending with data displays in the Control Center. In progressive stages, these simulated operations were built up to represent the maximum mission load conditions; system integration and data compatibility were demonstrated during the summer of 1974.

A succeeding series of ground data system tests, using the actual tracking stations and test models of the Viking Orbiter and Lander, provided training for the personnel of the Flight Operations System as well as the Deep Space Network and Mission Control and Computing Center, and established the readiness of the Tracking and Data System for supporting the Mission.

In this volume, the Viking Project and the deep space and near-Earth elements of the System are described first. Then follows an outline of the essential elements of Viking planning: the balancing of requirements and capabilities, the definition of system interfaces, planning activities, and the final system design. Next, the elements of the implementation phase are discussed: facilities changes, development of new techniques, and interface and system integrity established through testing and training. A bibliography of pertinent Viking Project and Network documentation and a chronology of key events and activities of the prelaunch phase completes this first volume.

II. THE VIKING PROJECT

A. CONCEPT

The roots of the Viking Project go back to the 1968 summer studies of the Space Science Board of the National Academy of Sciences. These studies defined the desirability of the search for extraterrestrial life in our solar system on the surface of Mars, using unmanned spacecraft. In-house technical studies of a possible 1973 Mars Lander mission were begun at Langley Research Center in March 1968; related studies at the Jet Propulsion Laboratory were called for in September, and the National Aeronautics and Space Administration Office of Space Science and Applications approved a Viking Mars 1973 Program in November. The Project Approval Document was signed in February 1969.

The scientific background to Viking stems from the Mariner missions to Mars in 1964-65, 1969, and 1971-73. In 1965, Mariner 4 was the pioneering flight to Mars, providing a few television pictures of its cratered surface and defining the physical parameters of its atmosphere in a fast flyby mission. In 1969, Mariner 6 and Mariner 7 conducted more extensive approach and flyby imaging, acquired spectral data on atmospheric composition, and did initial thermal mapping. Mariner 9, placed in orbit about Mars in 1972, surveyed the entire surface at various image resolutions and performed extensive spectral, thermal, and gravitational studies. A landing mission was the next logical step. Considerable program planning of a large and complex orbiter-lander mission had been carried out under the Voyager Program, which was terminated in its early stages in favor of the more conservative Mariner 1969, Mariner 1971, and Viking mission set.

The concept of the Viking Project involved two Viking spacecraft, each consisting of an Orbiter and a Lander, boosted by a Titan/Centaur Launch Vehicle into a Mars trajectory at the 1975 opportunity. On arrival at the planet, each spacecraft was to be placed in orbit; following a mapping survey and landing-site verification, the Lander capsule was to separate from its Orbiter, and through a number of stages, the Lander was to be brought to the Mars surface. This series of events is represented pictorially in Fig. 1. Although the primary science investigations would be carried out by the Lander on the Martian surface, a significant science return would be obtained from experiments conducted by the Orbiter in orbit and by the Lander during its descent through the Martian atmosphere.

B. OBJECTIVES AND MISSION SUMMARY

The basic formal objective of the Project is to advance significantly our knowledge of the planet Mars by direct measurements in the atmosphere and on the surface, and observations of the planet during approach and from orbit during the 1975 opportunity. Particular emphasis

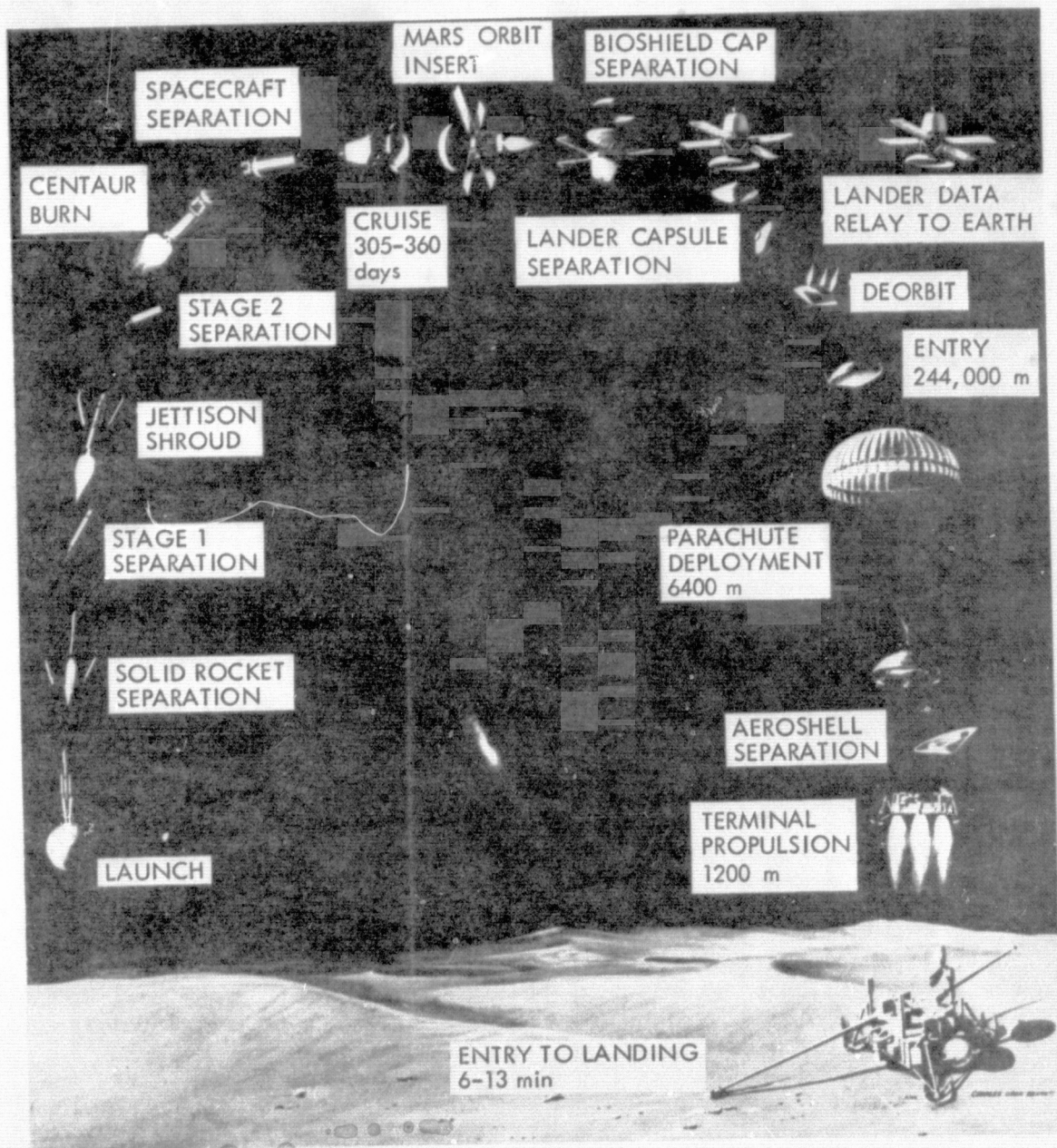

Fig. 1. Viking mission events: launch to landing

REPRODUCIBILITY OF THE ORIGINAL PAGE IS POOR

is placed on obtaining biological, chemical, and environmental factors relevant to the existence of life on the planet at this time, at some time in the past, or the potentials for the development of life in the future.

The detailed objectives during the various mission phases are:

- (1) Orbital Phase:
 - (a) To obtain image, thermal, and water vapor information to be used in landing site selection for the Landers.
 - (b) To obtain repeated image, thermal, and water vapor coverage of landing sites during lifetime of the Landers on the surface.
 - (c) To obtain image, thermal, and water vapor information to be used in selection of landing sites for future missions.
 - (d) To obtain image, thermal, and water vapor information to be used in the study of dynamic and physical characteristics of the planet and its atmosphere.
 - (e) To conduct scientific investigations using the Orbiter radio system.
- (2) Entry Phase: to determine the atmospheric structure and composition.
- (3) Landed Phase:
 - (a) To visually characterize the landing site.
 - (b) To search for evidence of living organisms.
 - (c) To search for and characterize organic compounds.
 - (d) To determine the elemental composition of the surface material.
 - (e) To determine the atmospheric composition and its temporal variations.
 - (f) To determine the temporal variations of atmospheric temperature, pressure, and wind velocity.
 - (g) To determine the seismological characteristics of the planet.
 - (h) To conduct scientific investigations using the Lander radio, engineering sensors, magnets, and other information that may be obtained from the Lander.

The launch window would occur during August - September 1975. The two Titan/Centaur/Viking space vehicles would be launched from Kennedy Space Flight Center, not less than ten days apart. Typical launch-phase Earth tracks are shown in Fig. 2. The two composite Viking spacecraft would be tracked continuously during the transit phase, which lasts approximately 11 months. On arrival (late June for Mission A, early August for Mission B), the Orbiter propulsion subsystem would place each composite spacecraft in orbit. Typical transit trajectories are shown in Fig. 3.

Orbiter-based scientific operations begin during the approach, and continue through the orbit phase. The first Orbiter would conduct a few weeks' survey and verification of the proposed landing sites, after which the Lander capsule would be separated to enter the Mars atmosphere (protected by an aeroshell), with deceleration by a parachute, and then soft land under control of its descent engines.

On the surface, the Lander would conduct visual observations, atmospheric measurements, and a variety of experiments on surface samples. Most of its telemetry data would be relayed by very high frequency (VHF) link to the Orbiter, which would continue its observations of the planet as well. Sampled measurements would be telemetered directly to Earth during a duty cycle of about two hours per day.

On arrival, the second Viking would execute somewhat similar events. The second Lander would enter the atmosphere and descend to the planet surface about two weeks after the first Lander. The communications configuration between the Orbiters and Landers on Mars and the tracking stations on Earth at this stage is depicted in Fig. 4.

About two months of surface operations were planned for each Lander. The nominal Viking Mars mission would conclude just before solar conjunction (November 15, 1976) when decreasing Sun-Earth-spacecraft angle would interrupt communications between the Network and the spacecraft.

Extended mission operations up to two years in duration were planned to follow the resumption of Earth-Mars communications, in December 1976.

C. FUNCTIONAL ORGANIZATION

The Viking Project embodies six basic functional elements that must be operated together by the Viking Flight Team to execute the mission. These functional elements are summarized in Fig. 5.

The Titan IIIIE/Centaur was a new launch vehicle configuration provided by the Lewis Research Center (Cleveland, Ohio) and planned for use in the Helios and Mariner Jupiter-Saturn 1977 missions as well as Viking. The vehicle is shown in Fig. 6.

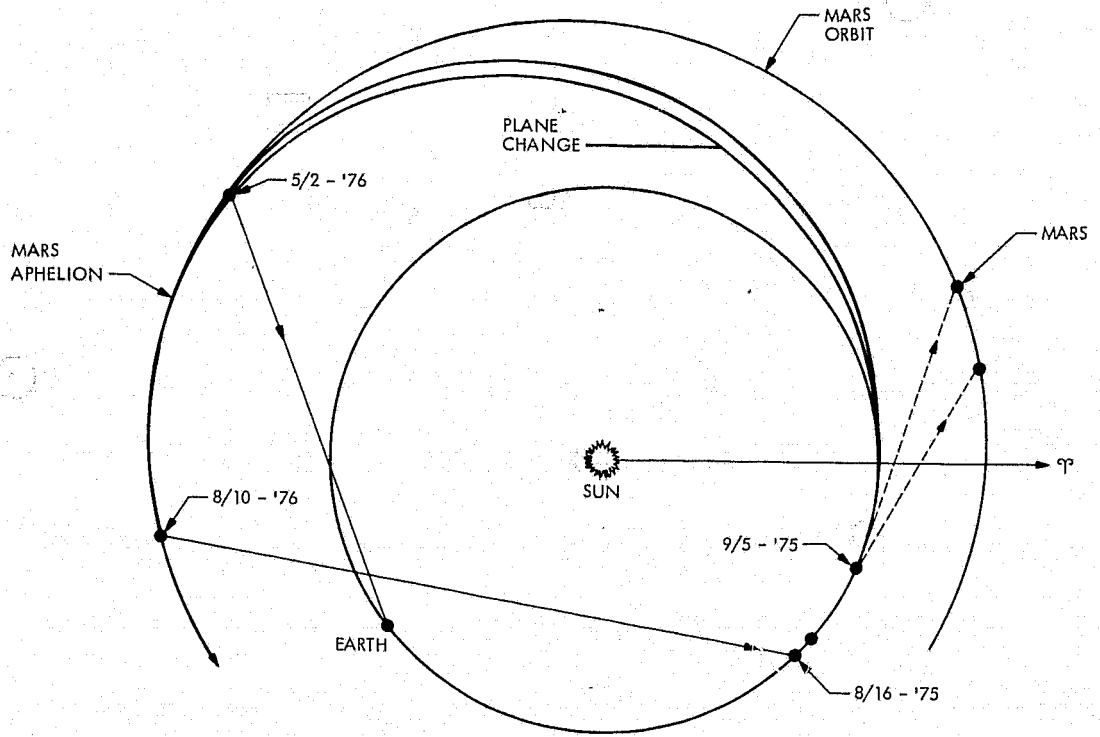

Fig. 3. Earth-Mars trajectories 1975 Viking launch

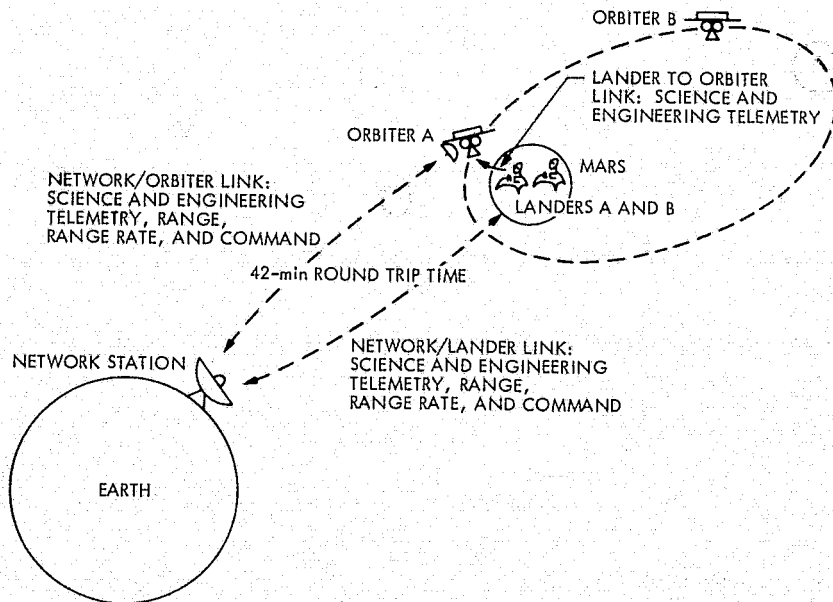

Fig. 4. Communication links: two landers, two orbiters

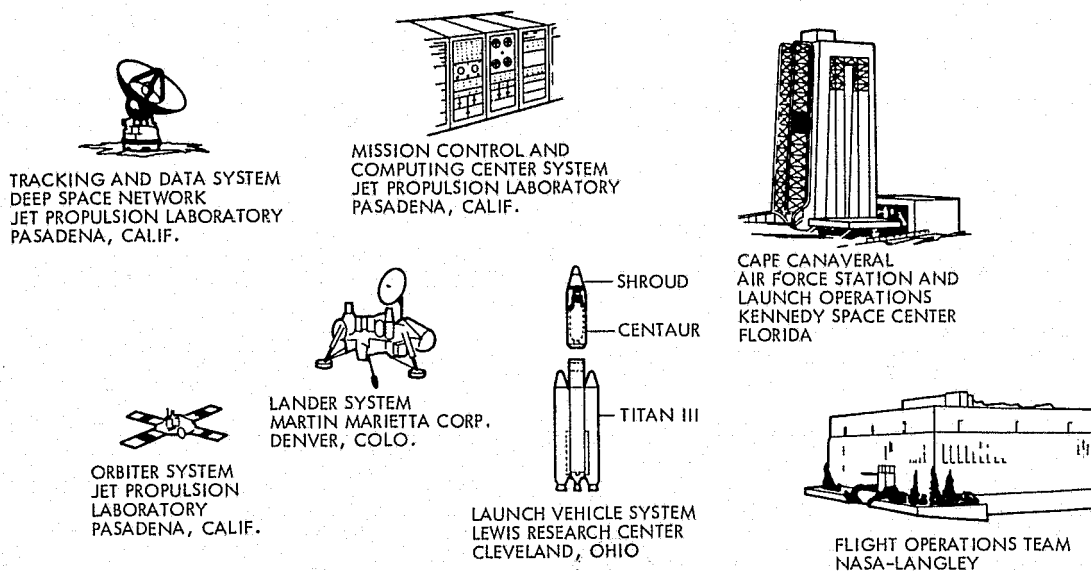

Fig. 5. Elements of the Viking Project

The Viking Orbiter design was based on earlier Mariner spacecraft designs, but strengthened and modified to carry the Lander capsule. It was provided by the Jet Propulsion Laboratory. The Spacecraft configuration is given in Fig. 7, and its scientific experiments are listed in Table 1.

The design of the Viking Lander, which was built by the Martin-Marietta Corporation for Langley Research Center, represented a new design to survive Martian entry, landing, and surface environment. It is powered by radioisotope thermoelectric generators and has the capability of direct two-way communications with Earth, as well as a one-way very high frequency telemetry link to the Orbiter. Its configuration is shown in Fig. 8, and its scientific experiment complement given in Table 1.

Following launch from the Launch Complex 41 at Cape Canaveral, Florida, the Viking mission will be conducted by a Flight Operations Team responsible for the operation of the spacecrafts and for mission operations to the end of the mission. The team consists primarily of trained operating personnel housed in the Mission Control and Computing Center at the Jet Propulsion Laboratory and directed by Project Management staff from the Langley Research Center, Hampton, Virginia.

The Mission Control and Computing Center System is defined as "a selected collection of Earth-based equipment, software, personnel, and procedures required to prepare and transmit commands; acquire, process, and display metric, science, and engineering data, and furnish it in an organized manner for Project analyses." These resources were provided to the Viking Project by the Jet Propulsion Laboratory and

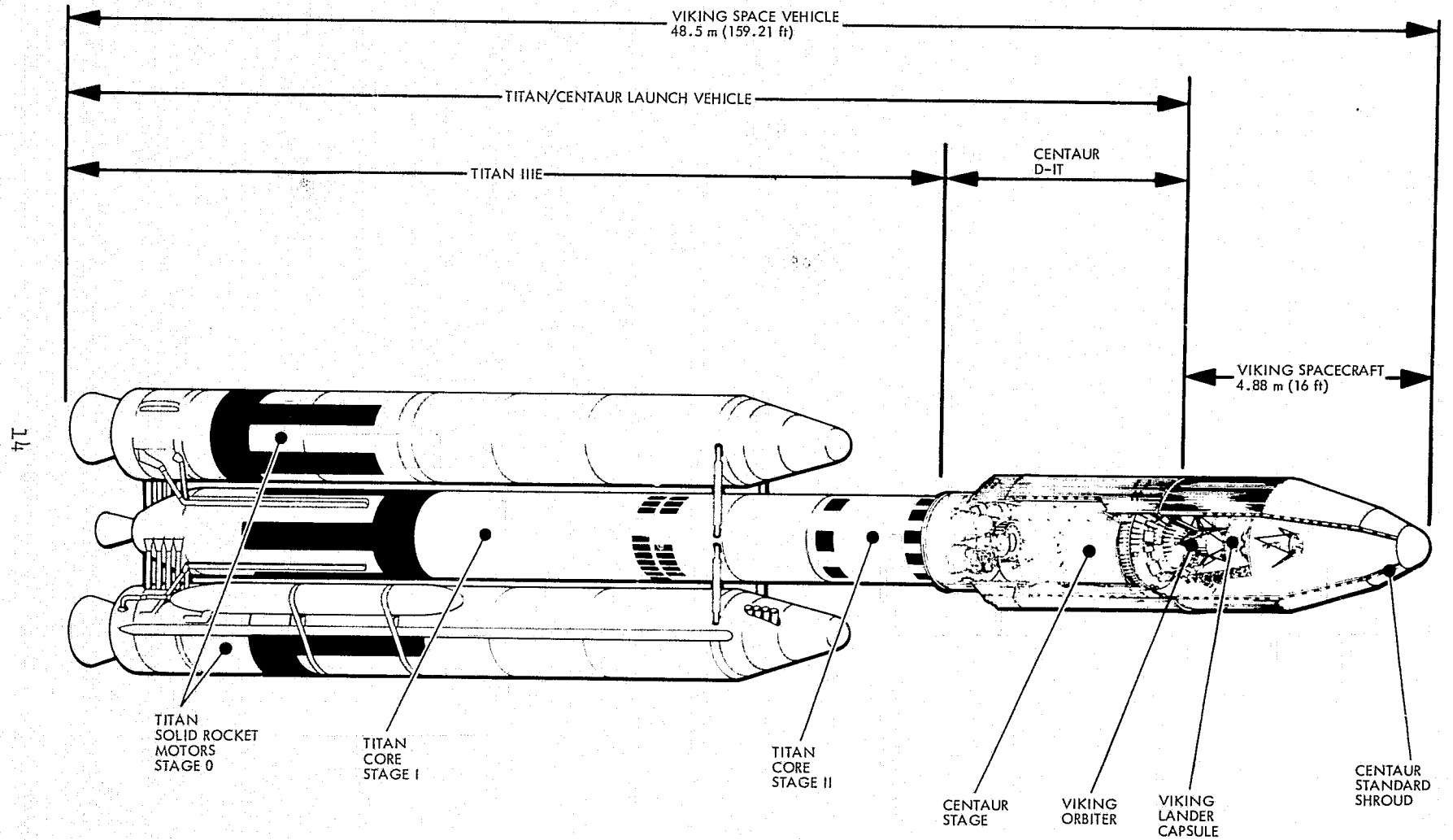

Fig. 6. Titan IIIE/Centaur D-IT launch vehicle

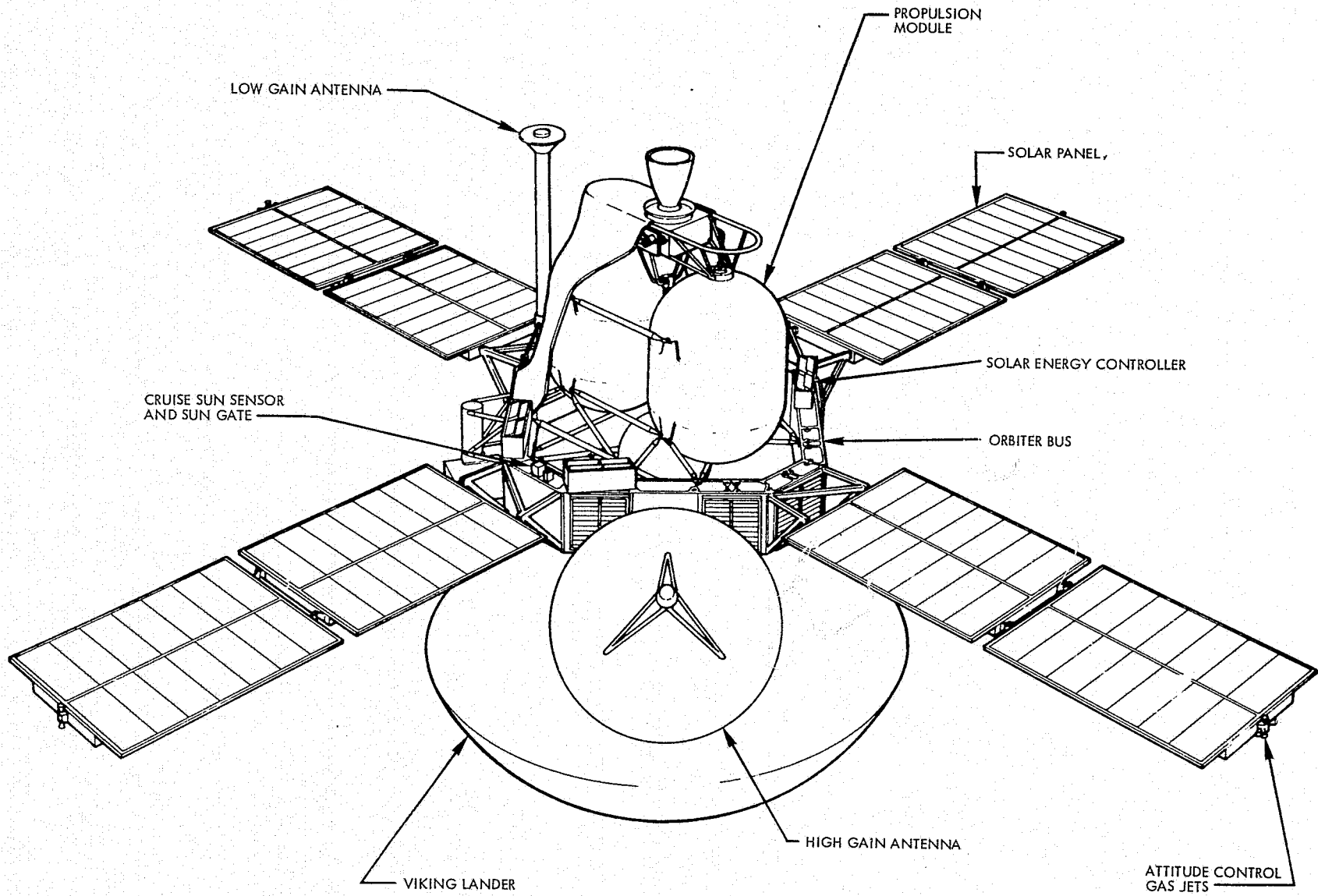

Fig. 7. Viking Orbiter configuration

REPRODUCIBILITY OF THE ORIGINAL PAGE IS POOR

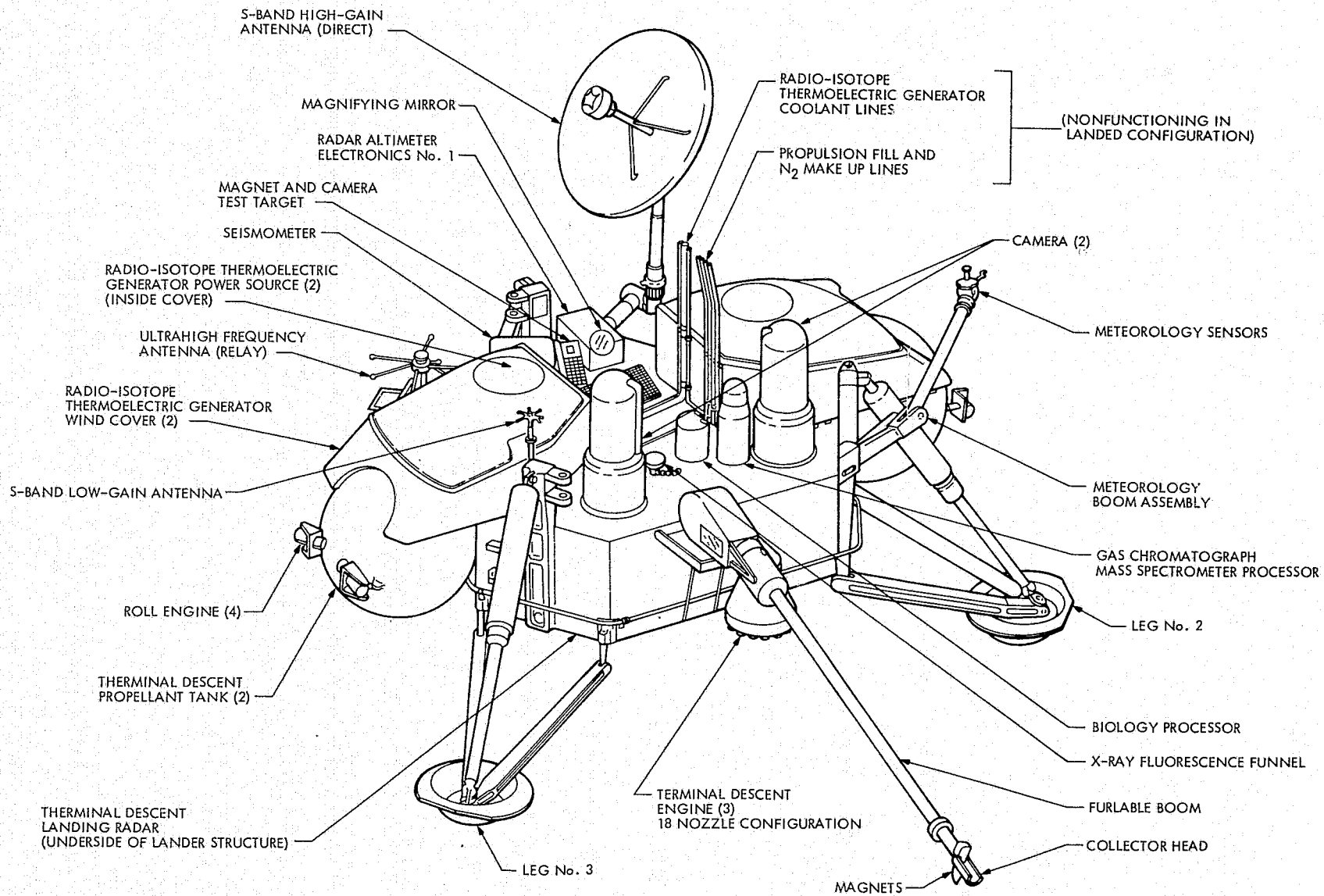

Fig. 8. Viking Lander

Table 1. Viking scientific experiments

Mission phase	Experiments	Principal scientists
Orbiter	Television imaging	M.H. Carr, U.S. Geologic Survey
	IR thermal mapping (surface)	H.H. Kieffer, U. California, L.A.
	Water vapor mapping (infrared)	C.B. Farmer, Jet Propulsion Laboratory
	S/X-band radio	W.H. Michael, Langley Research Center
Aeroshell entry	Ion and electron retarding potential analyses	A.O.C. Nier, U. of Minnesota
	Neutral gas mass spectrometry	A.O.C. Nier, U. of Minnesota
	Upper atmospheric pressure and temp- erature measure- ments	A.O.C. Nier, U. of Minnesota
Lander	Imaging	T.A. Mutch, Brown U.
	Biology detection	H.P. Klein, Ames Research Center
	Molecular mass spectrometry, gas chromatography, and X-ray spectrom- etry	K. Biemann, Massachusetts Institute of Technology
	Meteorology: varia- tions in pressure, temperature, and wind velocity	S.L. Hess, Florida State U.
	Seismometry (3 axes)	D.L. Anderson, California Institute of Technology

Table 1 (contd)

Mission phase	Experiments	Principal scientists
Lander (contd)	Surface magnetic and physical properties	R.B. Hargraves, Princeton U. R.W. Shorthill, U. of Utah

were used continuously throughout the mission as an integral part of the Viking ground data system.

The Viking Project encompasses support from the several agencies shown in Fig. 9. It is managed by Langley Research Center, under the National Aeronautics and Space Administration Office of Space Science Program management, with the Martin Marietta Corporation as contractor for the Viking Lander. The Launch Vehicle System is managed by Lewis Research Center, with Martin-Marietta and General Dynamics Convair as vehicle contractors. The Jet Propulsion Laboratory is responsible for the Orbiter System, Tracking and Data System, and the Mission Control and Computing System. The Cape Canaveral Air Force Station and Kennedy Space Center provided support for all launch operations activities.

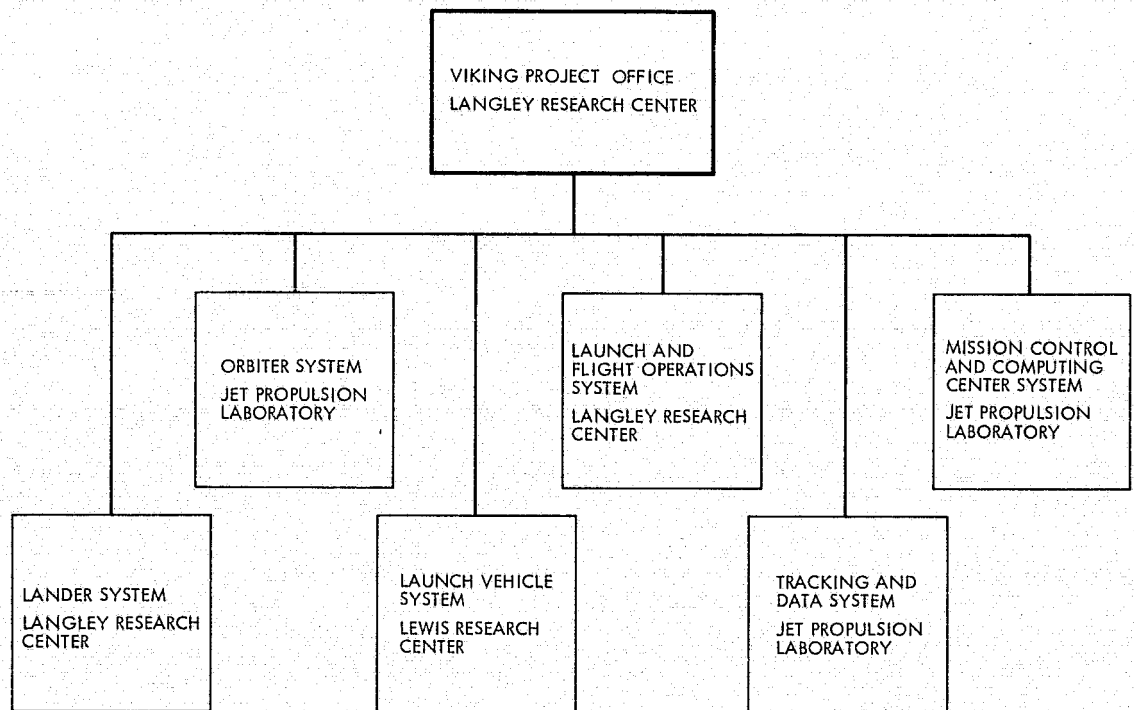

Fig. 9. Viking Project supporting agencies

D. REQUIREMENTS FOR TRACKING AND DATA SYSTEM SUPPORT

1. General

Viking Project requirements for System support covered three technical categories: metric data support, telemetry recovery (including scientific data), and command link support. These were divided by reason of equipment organization into two chronological phases: near-Earth and deep space, as defined in Section III. The requirements specify support coverage (in time), character (e.g., signal frequency), and quality (accuracy of data), with, in some cases, priority of requirement. They also prescribed the creation of data records and their transmittal to the Project, using the capability described in Section III. In addition to these requirements to support Viking mission activities, the System was also required to support certain prelaunch activities to demonstrate compatibility with interfacing systems of the Project and readiness to support mission operations.

2. Near-Earth

Near-Earth requirements included radars to track the launch vehicle, generate metric data, and transfer it in real time to the Real-Time Computing System for computation of trajectories and downrange acquisition information. Radio metric data acquired in this phase were to be processed to provide initial spacecraft orbital elements and targeting information, as well as initial acquisition information for the Deep Space Stations. A typical launch trajectory profile is given in Fig. 10. Telemetry data were to be acquired and recorded, with real-time transmission to range control center and/or relay to the Control Center of selected data (see Fig. 11). Commands to the spacecraft (besides checkout) were sent by the Deep Space Network only. The Network avoided commands during the prelaunch checkout operations and started commanding the spacecraft postlaunch shortly after initial acquisition by the Network.

A summary of the Viking requirements for near-Earth support is given by Fig. 12. Metric data, launch vehicle telemetry data, and spacecraft telemetry data are tabulated within the figure.

The mandatory (M) classification is the minimum requirement that is essential to the achievement of program, mission, or test objectives for which it is specified. (If these requirements are not supported, a decision not to launch is a possibility.) Required (R) designates support of material aid in achievement of all objectives, and is necessary for detailed analysis of system performance, but not critical. Desired (D) designates support in addition to the mandatory or required, and that may be accumulated for long-term analysis of system performance. Inability to attain these data will not compromise the achievement of an objective.

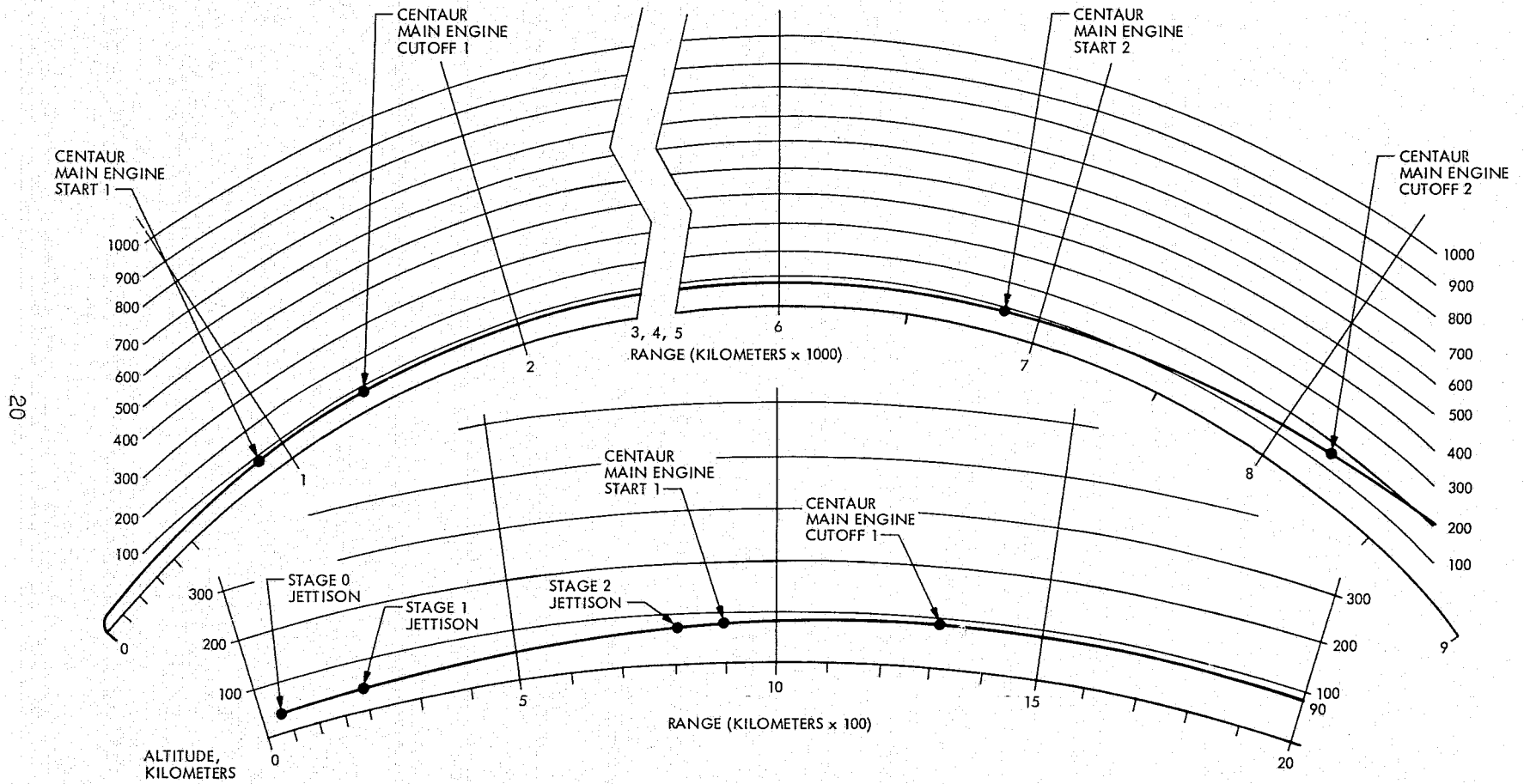

Fig. 10. Viking launch trajectory

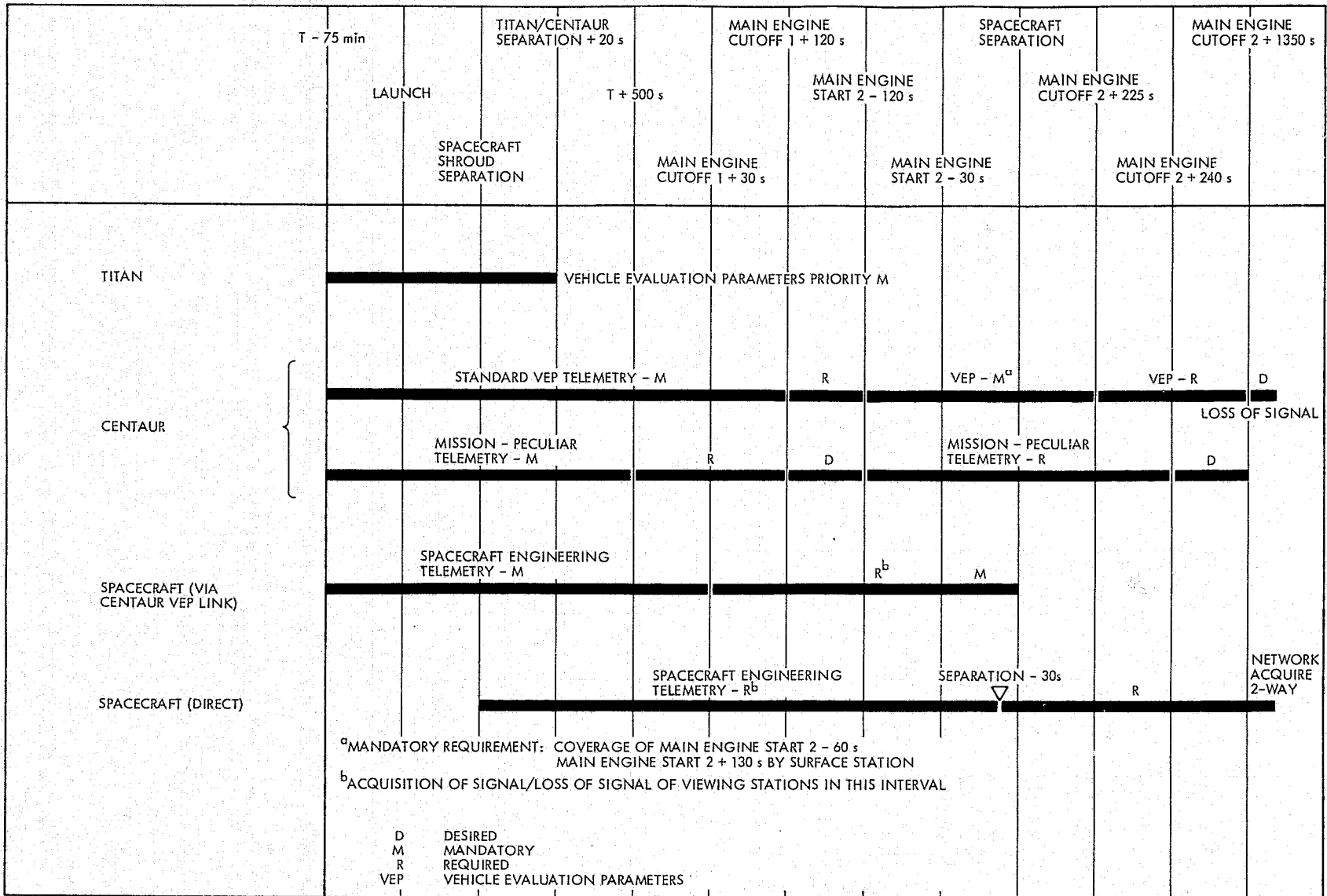

Fig. 11. Viking near-Earth telemetry coverage

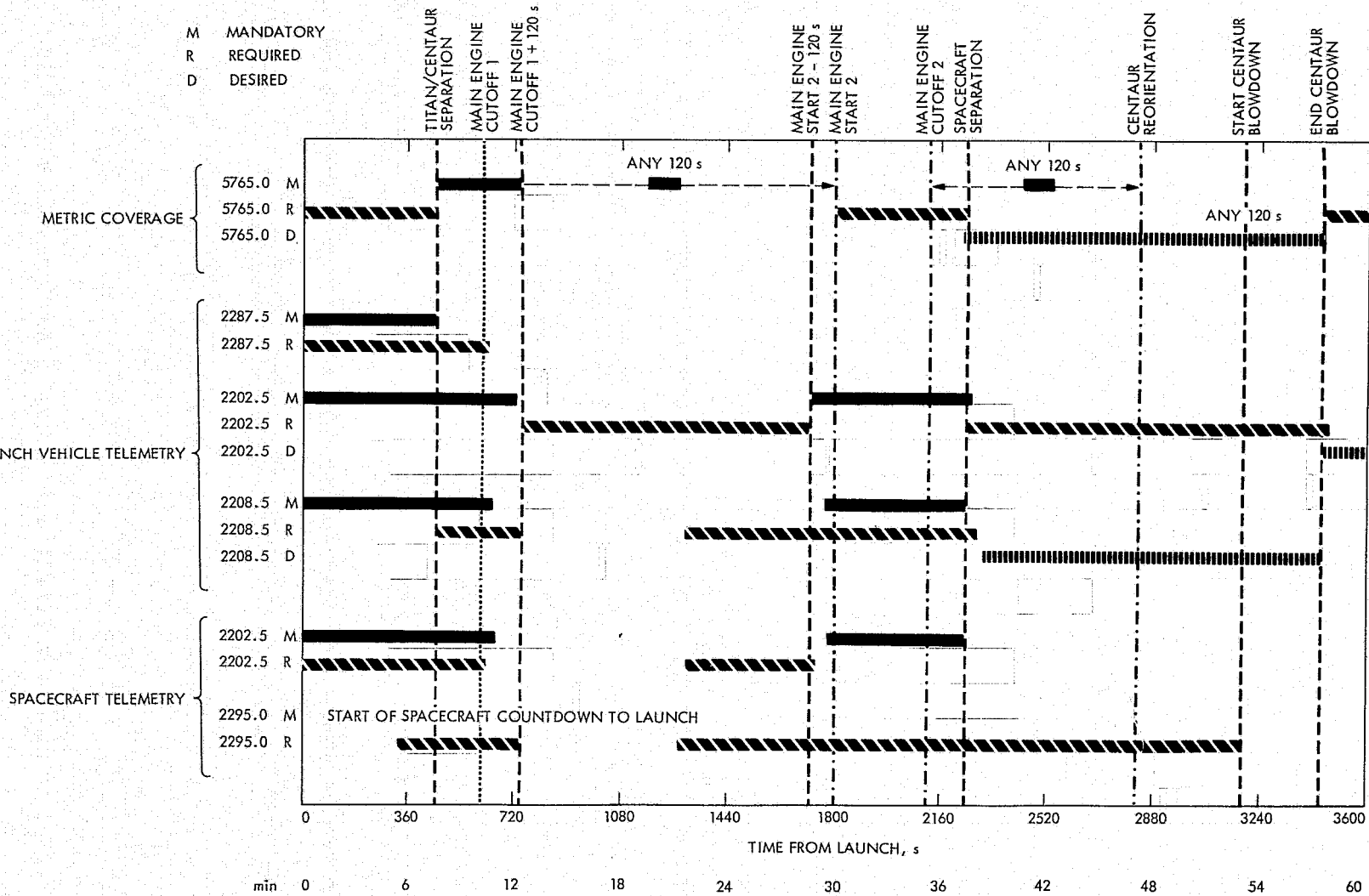

Fig. 12. Summary of near-Earth Tracking and Data System support requirements by Viking

3. Deep Space Station Support

A set of three 26-meter stations (Stations 11 (Goldstone), 42 (Australia), and 61 (Spain), were required as the primary stations for cruise support until limiting signal conditions required transfer to the 64-meter subnet. Twenty-six meter and 64-meter subnets (Stations 11, 14 (Goldstone), 42/43 (Australia), and 61/63 (Spain)) were required for Mars operations support. A second 26-meter subnet (Stations 12 (Goldstone), 44 (Australia), and 62 (Spain)) was to provide support for the limited periods shown in Fig. 13. Shortly after launch, when telecommunications requirements exceeded the capability of the 26-meter subnet, the 64-meter stations were to be employed to provide the necessary telemetry support. Planned coverage is given in Fig. 13. Full planetary ranging capability was required at Stations 11, 14, 43, and 63 only. This capability could be shared at Stations 42/43, and 61/63. Dual S- and X-band receive capability was desired at Stations 14, 43, and 63. Telemetry and command data were to be received and processed as required, for transmission to the Mission Control Center.

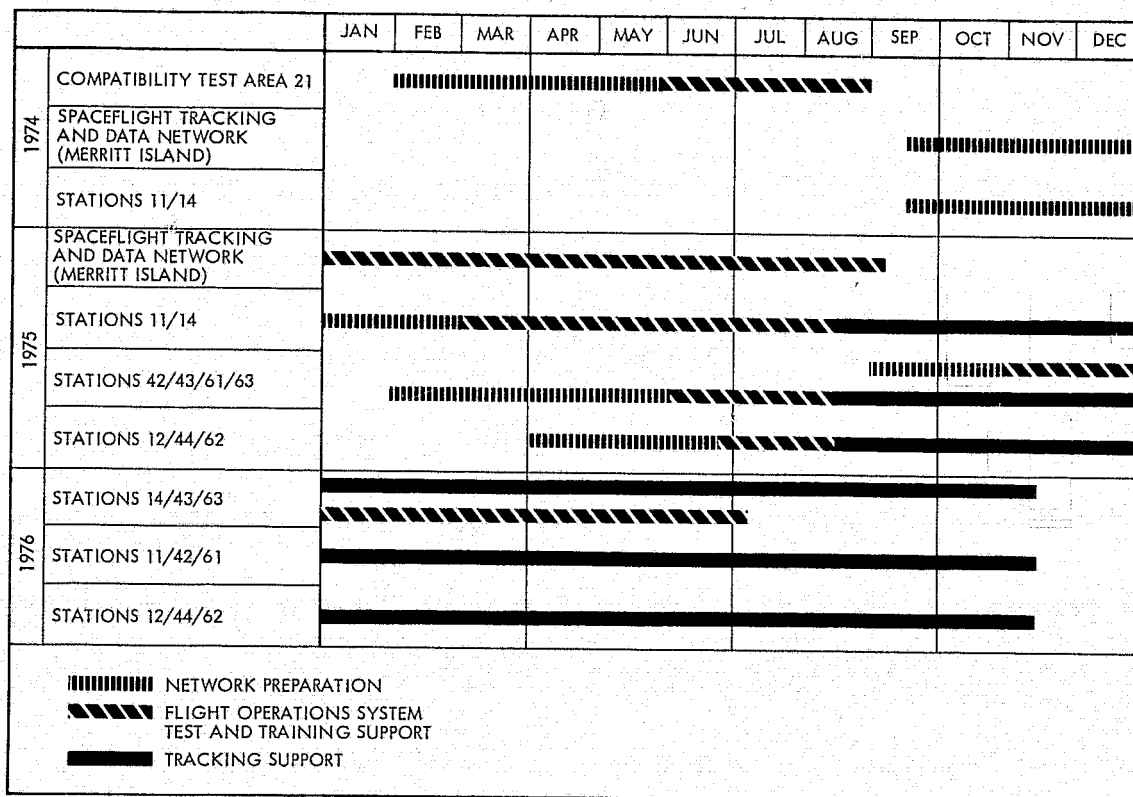

Fig. 13. Network support for Viking: coverage for tracking, telemetry, and command; test and training support

4. Ground Communications Facility Support

Standard National Aeronautics and Space Administration Communications and Deep Space Network/Ground Communications Facility voice, teletype, high-speed, and wideband circuits were requested to meet communications and data transmission requirements consistent with the telemetry, metric command, and simulation data rates.

5. Simulation Support

Capability was to be provided for the generation of Network simulation data, as well as for accepting a simulated command-responsive telemetry data stream from the Project.

6. Network Operations Control Center

The Network Operations Control Center was to provide for control and monitoring of Network performance. All incoming data was to be validated at this point while being simultaneously transferred to the Viking Mission Control and Computing Center for real-time use by the Flight Operations System. Any missing or bad data would be recalled from the stations and provided to the Project within 24 hours as part of the Intermediate Data Records.

7. Backup Capability

The Project assumed that elements of the 26-meter subnet would be used to provide backup capability for the 64-meter subnet in the event of failures from which rapid recovery at the affected 64-meter stations was not otherwise feasible. The Project recognized these factors in its mission design activities, particularly during critical sequences of the mission.

8. Operational Readiness

In response to Project requirements, the Deep Space Network implementation plan was to provide for all major hardware and software necessary to reconfigure the Network for Viking to be on site (including overseas sites) prior to Summer 1975 launches. However, system testing of all hardware and software in the planetary configuration would not take place at the overseas sites until November/December 1975.

9. Station Coverage

Requirements for Deep Space Station coverage are shown in Tables 2 and 3. The unit of coverage is the average 12-hour pass which includes an 8-hour view period. This coverage assumed launches on August 11

Table 2. Deep Space Network coverage for flight operations, calendar year 1975
(average number of 12-hour passes per week)

Deep Space Station subnets, key events	Week number																				Notes	
	33	34	35	36	37	38	39	40	41	42	43	44	45	46	47	48	49	50	51	52		
11, 42, 61	3	10	21	21	21	21	21	12	10	11	11	11	20	21	21	21	21	21	21	21	(a) Coverage shown is typical and is that associated with a particular set of launch and encounter dates. Coverage requirements are subject to adjustment as the launch and encounter dates vary within the bounds of Launch Date - Encounter Date strategy.	
14, 43, 63	17	21	21	21	21	21	21	19	14	14	14	14	3	1	1	0	4	4	4	4	(b) A Viking Orbiter constraint limits to 3 hours the period that Engineering telemetry is not received. Consequently, during interplanetary cruise, when only one station is "up," the spacecraft will be tracked alternately 2 hours out of every 5 hours, with 1 hour available for switching from one to the other.	
12, 44, 62	0	0	0	0	0	0	0	0	0	4	4	4	3	5	7	7	6	7	6	0	0	(c) Station 14 X-band radar mapping passes have been added in weeks 45, 46, 47, 49, and 52, for 1975 and in weeks 1-6 and 9 in 1976.
Mission key events	1	3	4					5												6		

Key to 1975 Mission Events

- 1 = Launch A, 8-12
- 2 = Midcourse maneuver 1A, 8-17
- 3 = Launch B, 8-21
- 4 = Midcourse maneuver 1B, 9-23
- 5 = Launch B plus 40 days, 9-30
- 6 = Launch Helios B, 12-8

Table 3. Deep Space Network coverage for flight operations, calendar year 1976
(average number of 12-hour passes per week)

Deep Space Station subnets, key events	Week number																																																
	1	2	3	4	5	6	7	8	9	10	11	12	13	14	15	16	17	18	19	20	21	22	23	24	25	26	27	28	29	30	31	32	33	34	35	36	37	38	39	40	41	42	43	44	45	46	47		
11,42,61	21	21	21	21	21	15	8	8	10	17	18	18	15	10	8	8	6	6	8	11	10	11	11	20	21	21	21	21	21	21	21	21	21	21	21	21	21	21	21	21	21	21	21	21	21	21	21	21	3
14,43,63	5	6	7	4	4	10	21	21	18	7	7	7	17	21	21	21	21	21	21	21	21	21	21	21	21	21	21	21	21	21	21	21	21	21	21	21	21	21	21	21	21	21	21	21	21	21	21	3	
12,44,62	0	0	0	0	0	0	0	0	0	0	3	3	3	2	0	0	0	0	0	0	0	0	0	0	0	0	0	0	0	0	0	0	0	0	0	0	0	0	0	0	0	0	0	0	0	0	0	0	0
Mission key events							7	8	9		10		11	12		13	15	16	17		18	19		20	21		22		23	24	25	26		27		28		29											

Key to 1976 Mission events

- 7 = Viking A scan calibration
- 8 = Viking B scan calibration I, 2-16
- 9 = Helios perihelion, 2-23 - 3-22
- 10 = Assumed period of high solar activity, 3-22
- 11 = Viking A scan calibration II, 4-12
- 12 = Viking B scan calibration II, 4-19
- 13 = Viking A visual calibration I, 5-3
- 14 = Viking A encounter minus 40 days, 5-8
- 15 = Viking B visual calibration I, 5-10
- 16 = Midcourse maneuver Viking A, 5-17
- 17 = Viking A visual calibration II, 5-24
- 18 = Viking A encounter minus 10 days, midcourse maneuver, 6-8
- 19 = Viking A encounter, 6-18
- 20 = Touchdown for Viking A, 7-4
- 21 = Viking B encounter minus 30 days, midcourse maneuver, 7-7

- 22 = Viking B encounter, 8-7
- 23 = Touchdown for Viking B; Viking A low activity begins, 9-4
- 24 = Viking A desynchronization, 9-6
- 25 = Viking B plane change, 9-13
- 26 = Viking B resynchronization, 9-20
- 27 = Viking A synchronization; Viking B desynchronization, 10-4
- 28 = Viking B synchronization, 10-2
- 29 = End of Mission, 11-15

NOTE: See Table 2 Note.

and 21, 1975 (both delayed), Mars arrivals on June 18 and August 7, 1976, and landings on July 4, and September 4, 1976.

10. Data Requirements

Radio metric data were required during cruise for navigation purposes, and also during orbital operations for orbit determination, ephemeris studies and radio science experiments.

Radio metric data capabilities of the 26-meter and 64-meter subnets are listed here.

a. 26-Meter Subnet

- (1) Planetary ranging and Differenced Range Versus Integrated Doppler on one S-band carrier at Stations 11, 42, and 61 shared with 64-meter stations at Stations 42 and 61.
- (2) Two-way S-band doppler simultaneously with planetary ranging.
- (3) Planetary ranging and Differenced Range Versus Integrated Doppler at Station 11 only.
- (4) Planetary ranging capability at Stations 42 and 61 to be shared with their conjoint 64-meter stations.
- (5) Two-way S-band doppler at Stations 12, 44, and 62.

b. 64-Meter Subnet

- (1) Planetary ranging on one S-band, two-way carrier and one coherent X-band, one-way downlink carrier simultaneously at Stations 14, 43, and 63. The S-band ranging capability to be shared at conjoint Stations 43 and 63.
- (2) One two-way S-band doppler stream and one one-way coherent X-band doppler stream available at the same time as planetary ranging is in operation.
- (3) Differenced Range Versus Integrated Doppler data available at S- and X-band when ranging is in operation.
- (4) Possible combinations of data streams at each 64-meter station are summarized as follows:

D_s	R_s	D_x	R_x
1			
1	1		
2	1		
1	1	1	
1	1	1	1

Key:

D_s = one 2-way S-band doppler stream

D_x = one X-band downlink doppler stream

R_s = one S-band ranging stream

R_x = one X-band downlink ranging stream

- (5) Ground weather data and ionospheric data to be provided to the Project via postpass playback on high-speed circuits in accordance with formats of Mission Control and Computing Center to Deep Space Network Interface Requirements, Volume IV of Orbiter System, Lander System, Viking Mission Control and Computing Center System to Data System Interface Requirements Document.
- (6) Each 64-meter station provides two doppler counters. One will operate at S-band or X-band (one-way coherent) while the other will operate at S-band (two-way) only.
- (7) Each 64-meter station provides one planetary ranging system that can operate simultaneously by S-band (two-way) and X-band (one-way). The planetary ranging system will operate under input signal conditions $P_R/N_0 = -10$ dB for an acquisition time of 10 minutes.

Requirements for radio metric data accuracy are given in Table 4.

Telemetry coverage requirements varied with the phase of the mission. During the long cruise period, each Deep Space Station was required to receive one spacecraft at a time, each transmitting one engineering and one science channel. After the arrival of the second spacecraft at the planet, each 64-meter station was required to receive simultaneously two spacecraft, each transmitting one engineering and one science data stream.

Table 4. Deep Space Network radio metric data support -- accuracy

Item	Viking requirements (3σ)	Network capabilities (3σ)
1. Two-way S-band doppler accuracy (I) ^a	2.1 mm/s for 60-s interval	2.1 mm/s for 6-s count interval (2400 s round trip light time)
	40-ns (6-m) phase delay stability over 12-h pass	5.7 m over 12 h (2400 s round trip light time)
2. S-band ranging accuracy (Network only) (I)	100-ns (15-m) knowledge of ranging group delay at all times	Ranging System accuracy (1σ) due to all sources of error follows:
	100-ns (15-m) ranging group delay stability over 12-h pass	(1) High frequency noise 5.0 rms (2) Instability in range modulation group delay 2.0 m/12 h (3) Uncertainty in knowledge of frequency for 2400 s round trip light time 3.6 m (4) Station calibration error 2.5 m (5) Time of measurement error 1.0 m
3. S-and X-band accuracy (Orbiter or Lander and Network) (II)	300-ns (45-m) knowledge of range group delay stability over a 90-day period	Network contribution to overall ranging accuracy given in Item 2 for S-band
	300-ns (45-m) range group delay stability over a 1-day period	Network contribution to X-band ranging estimated same as for S-band

^aClassification of data accuracy requirements given thus: (I, II, III).

Table 4 (contd)

Item	Viking requirements (3σ)	Network capabilities (3σ)
4. Differenced Range Versus Integrated Doppler accuracy (Network only) (I)	30-ns (4.5-m) difference between S-band doppler and range group delay/12-h pass 40-ns (6.0-m) difference between S-band doppler and range group delay/15-min integration time	4.5 m/12 h (30 ns/12 h) For 15-min time between independent range samples, range error to be 6 m (40 ns) only if ratio P_R/N_0 is +2 dB or greater; doppler error over this period assumed negligible
5. S- and X-band differential accuracy requirements (Network) (II)	Difference between S- and X-band doppler phase delays over 12-h pass: 1.62 m (Network 0.6 m, Orbiter 1.5 m) Difference between S- and X-band ranging group delay over 12-h pass: 4.2 m (Network 3.0 m, Orbiter 3.0 m)	Network design goal for differential S- and X-band doppler phase delay 6.0 m over 12 h Network design goal for differential S- and X-band range group delay 3.0 m over 12 h
6. Doppler cycle slip (I, II)	Not more than a 10-cycle slip over one 12-h pass for navigation data	S-band cycle slipping due to Network receivers alone will be less than 30 cycles over one 12-h pass provided RF carrier level remains 10 dB or more above receiver threshold

Table 4 (contd)

Item	Viking requirements (3 σ)	Network capabilities (3 σ)
6. Doppler cycle slip (I, II) (contd)	Not more than a 1-cycle slip over one 12-h pass for radio science data	Represents design goal related to future capability and can be committed to Viking support on best-efforts basis only
7. Station location errors (I)	For each Station supporting Viking, maximum station location error with respect to mean pole, equator, and prime meridian (1903.3) to not exceed following values: (1) Distance from pole 1.8 m (2) Longitude 6.0 m (3) Distance from equator 45.0 m	For each Station supporting Viking, station location errors are function of following error sources in addition to Station observables range, doppler, and Differenced Range Versus Integrated Doppler normally provided to Project: (1) Station locations (2) Tropospheric effects (3) Universal time (4) Pole locations As part of its tracking data collection function, the Network will also provide these data to Project with following accuracy: Station locations . . . $\sigma_{r_s} = 0.6, \sigma_{\lambda} = 2.0, \sigma_z = 15m^b$

^bThis represents capability of Goldstone stations; it is assumed that an equivalent capability can be realized for overseas stations based on current Network implementation plans and postflight analysis of Mariner Mars 1971 orbit phase tracking data; data will be provided prior to launch and updated as necessary.

Table 4 (contd)

Item	Viking requirements (3σ)	Network capabilities (3σ)
8. Differenced Range Versus Integrated Doppler acquisition time (I)	15 min from receipt of two-way doppler 15-min intervals throughout Differenced Range Versus Integrated Doppler pass	Differenced Range Versus Integrated Doppler data became available at completion of first ranging component acquisition Differenced Range Versus Integrated Doppler sampling interval of 15 min provided consistent with $P_R/N_0 = +2$ dB or greater (Item 4)
9. Ranging acquisition time (I, II)	10 min for single uplink	Acquisition time depends on ranging signal-to-noise conditions in both uplink and downlink ^c
10. Timing (I)	Network master clock to U.S. Naval Observatory not greater than 1 ms Interstation time sync not greater than 150 μ s in cruise and 60 μ s in orbital phase	60 μ s at all stations 60 μ s throughout the mission at all stations
11. Polar motion data	Data of sufficient accuracy to permit instantaneous pole to be determined relative to mean pole of 1903.0 to following accuracy $3\sigma_x = 2.1$ m $3\sigma_y = 2.1$ m	Provide International Bureau of Time data on daily or weekly basis from which polar motion derived by Project; data provided on punched cards suitable for computer 1108 input

^cConditions under which Class I requirement could be met for a single uplink with Network operational planetary ranging system discrete spectrum for a probability of ranging error $P_e = 5\%$ were detailed in the Jet Propulsion Laboratory internal document.

Table 4 (contd)

Item	Viking requirements (3σ)	Network capabilities (3σ)
12. Earth rotation data	<p>Data of sufficient accuracy to permit difference between Atomic Time 1 (AT 1) and Universal Time 1 (UT 1) be determined by the following accuracy:</p> $3\sigma(\text{AT 1} - \text{UT 1}) = 12 \text{ ms}$	<p>Provide International Bureau of Time data on daily or weekly basis from which UT 1 may be derived by Project; data provided on punched cards suitable for 1108 computer input</p>
13. Tropospheric model	<p>Parameters of sufficient accuracy to reduce residual error (A_r) to following:</p> $3\sigma(A_r) = 3.0 \text{ meters at degrees evaluation}$	<p>Data taken continuously during mission in local area of each complex with following accuracy:</p> <p>Pressure ± 2.5 mbar</p> <p>Temperature $\pm 0.1^\circ\text{C}$</p> <p>Relative humidity $\pm 5\%$</p>
14. Differenced Range Versus Integrated Doppler Data	<p>Of sufficient accuracy to reduce residual error (after calibrating for troposphere) to following:</p> $3\sigma(\Delta\rho) = 5.0 \text{ m}$ <p>(This error includes Network errors reported in Item 4 plus contributions from Viking Orbiter of 45 ns (3 m))</p>	<p>Refer to allocation of Network error contributions given in Item 4</p>

Following the first landing sequence, each 64-meter Deep Space Station was required to receive simultaneously three spacecraft, i.e., two Orbiters and one Lander, each transmitting one engineering and one science data stream.

During critical or high-activity periods of previous missions, the requirements for hardware failure backup were met at the Deep Space Stations by scheduling a second station in parallel and/or the use of complete parallel strings of equipment readied in a standby state. The Viking mission, however, had unique requirements in that the critical high-activity periods would extend for up to five months continuously. During this period support would be required continuously without the benefit of backup stations or backup strings, at each 64-meter antenna Station.

During the planetary operations phase, all four spacecraft (two Orbiters and two Landers) would be within the beamwidth of a single antenna. The 64-meter subnet would be required to track up to three spacecraft (two Orbiters and one Lander) simultaneously and to provide one command uplink and process six telemetry subcarriers. As practically all of the Station equipment would be in use during three spacecraft operations, the configurations were designed to include new extensive "cross-switching" capabilities. These greatly increased the flexibility over current configurations and provided optimum use of the equipment for data processing in the case of an equipment failure. Also, the conjoint 26-meter antenna stations would provide uplink and backup telemetry hardware, accessible from their conjoint 64-meter antenna stations. Using a microwave link, Goldstone Stations 11 and 14 had the same capability.

The 64-meter station Viking telemetry configurations also were required to be capable of processing the types of data shown in Tables 5 and 6 from two Orbiters and one Lander simultaneously. The Station 14 Viking hardware capabilities are shown in Fig. 14. Figure 15 presents the Orbiter/Lander/Orbiter standard configuration.

Table 5. Viking Orbiter telemetry channels

Telemetry channel	Designator	Description	Bit rate	Subcarrier frequency, kHz
Low	B	Uncoded engineering data	8-1/3 or 33-1/3 bits/s	24.0
High	C	Coded (32, 6) science data	1,2,4,8, or 16 kbits/s	240.0
	A	Uncoded science data	1,2, or 4 kbits/s	240.0

Table 6. Viking Lander telemetry channels (for S-band direct link)

Telemetry channel	Designator	Description	Bit rate	Subcarrier frequency, kHz
Low	B	Uncoded engineering data	8-1/3 bits/s	12.0
High	A	Coded (32, 6) science data	250, 500, and 1000 bits/s	72.0

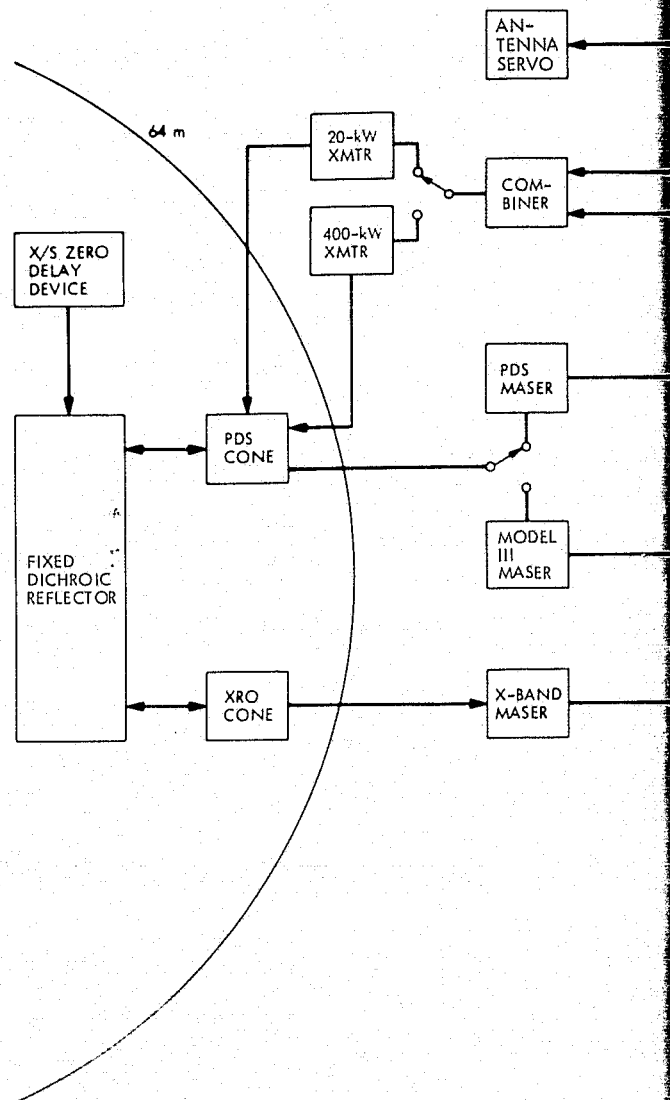

▲ INDICATES EQUIPMENT ADDED POSTLAUNCH

- | | | |
|------|-----------------------------------|-------|
| ANT | ANTENNA | |
| AODR | ANALOG ORIGINAL DATA RECORD | DRVID |
| APS | ANTENNA POINTING SUBSYSTEM | DSS |
| BDA | BLOCK DECODER ASSEMBLY | EXC |
| BLK | BLOCK | HSDL |
| CJM | COMMUNICATIONS JUNCTION MODULE | MET |
| CMA | COMMAND MODULATOR ASSEMBLY | MON |
| DDA | DATA DECODER ASSEMBLY | MW |
| DIS | DIGITAL INSTRUMENTATION SUBSYSTEM | OCC |
| DODR | DIGITAL ORIGINAL DATA RECORD | OLR |

FOLDOUT FRAME

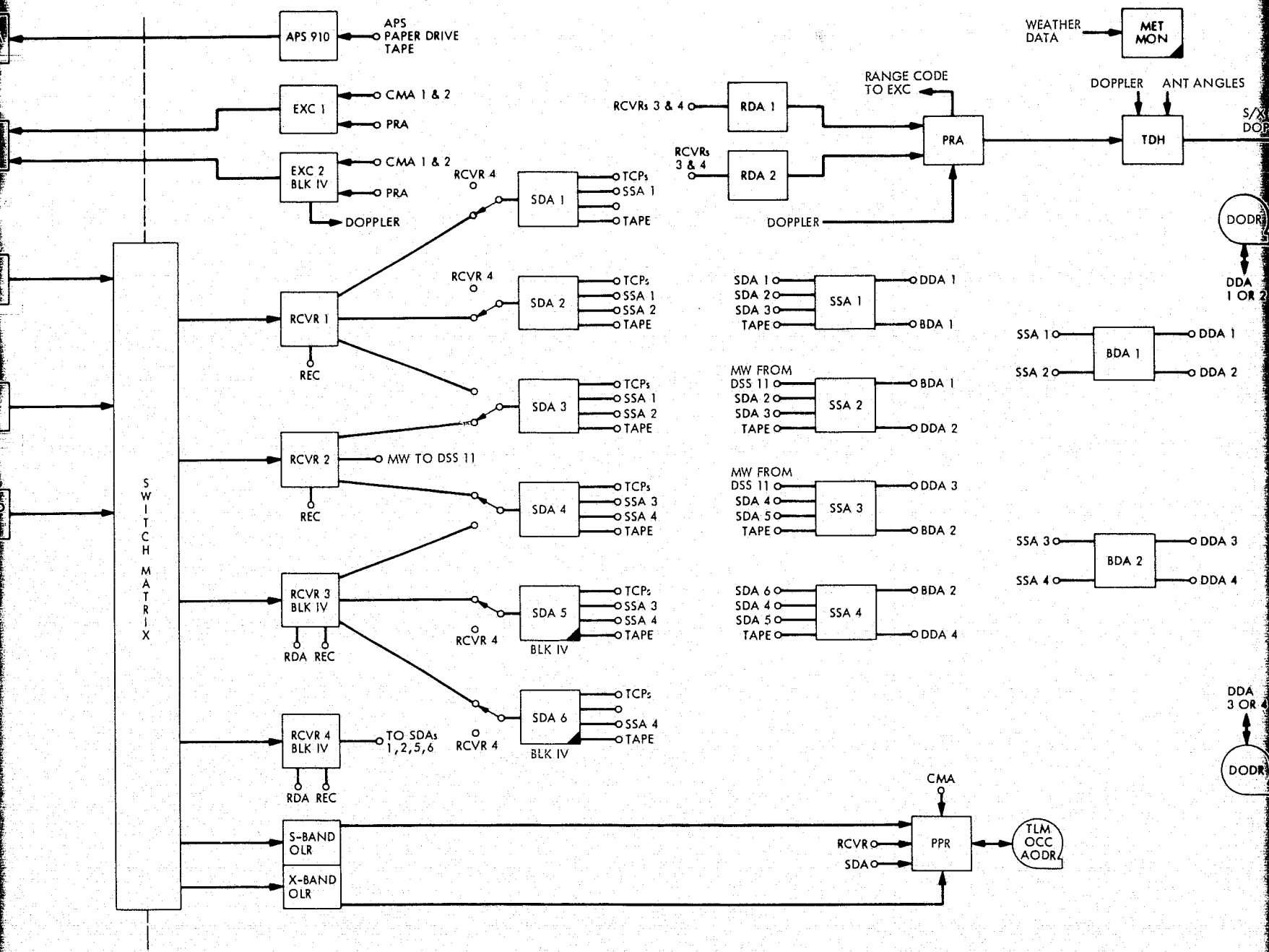

- | | | | | | |
|-------|---|------|---------------------------------|------|----------------------------------|
| DRVID | DIFFERENCED RANGE VERSUS INTEGRATED DOPPLER | PDS | POLARIZATION DIVERSITY S-BAND | TCP | TELEMETRY AND COMMAND PROCESSOR |
| DSS | DEEP SPACE STATION | PRA | PLANETARY RANGING ASSEMBLY | TDH | TRACKING DATA HANDLING SUBSYSTEM |
| EXC | EXCITER ASSEMBLY | RDA | RANGE DEMODULATOR ASSEMBLY | TLM | TELEMETRY SYSTEM |
| HSDL | HIGH-SPEED DATA LINE | RCVR | RECEIVER ASSEMBLY | TRK | TRACKING SYSTEM |
| MET | MISSION ELAPSED TIME | REC | RECORDING SUBASSEMBLY | WB | WIDEBAND |
| MON | MONITOR AND CONTROL SYSTEM | SCA | SIMULATOR CONVERSION ASSEMBLY | WBDL | WIDEBAND DATA LINE |
| MW | MICROWAVE | SDA | SUBCARRIER DEMODULATOR ASSEMBLY | XMTR | TRANSMITTER |
| OCC | OFF-LINE CONFIGURATION CONTROL | SSA | SYMBOL SYNCHRONIZER ASSEMBLY | XRO | X-BAND RECEIVE ONLY ASSEMBLY |
| OLR | OPEN LOOP RECEIVER | S/X | S-BAND, X-BAND | X/S | X-BAND, S-BAND |

Fig.

FOLDOUT FRAME 2

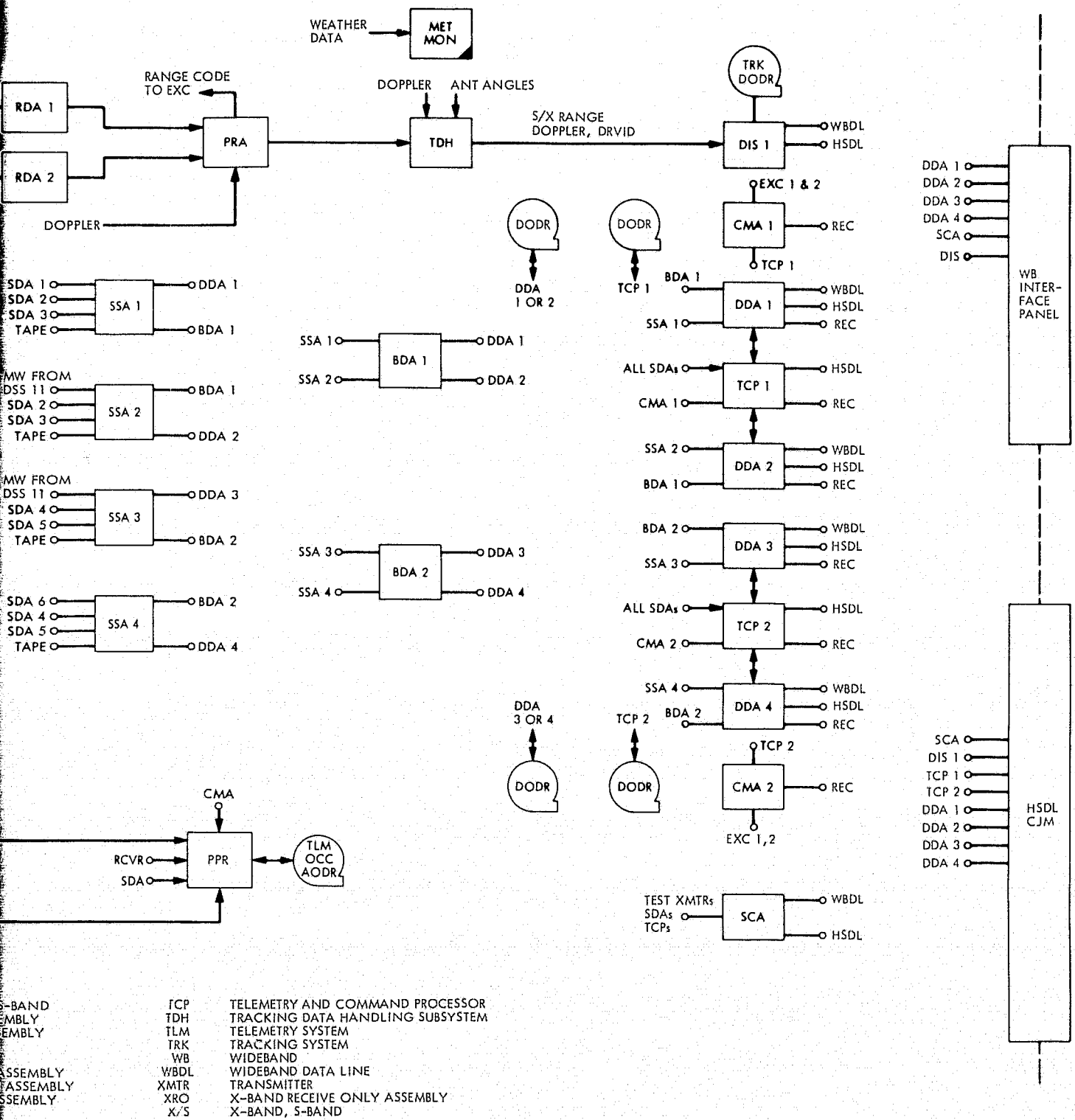

Fig. 14. Station 14 Viking hardware capabilities

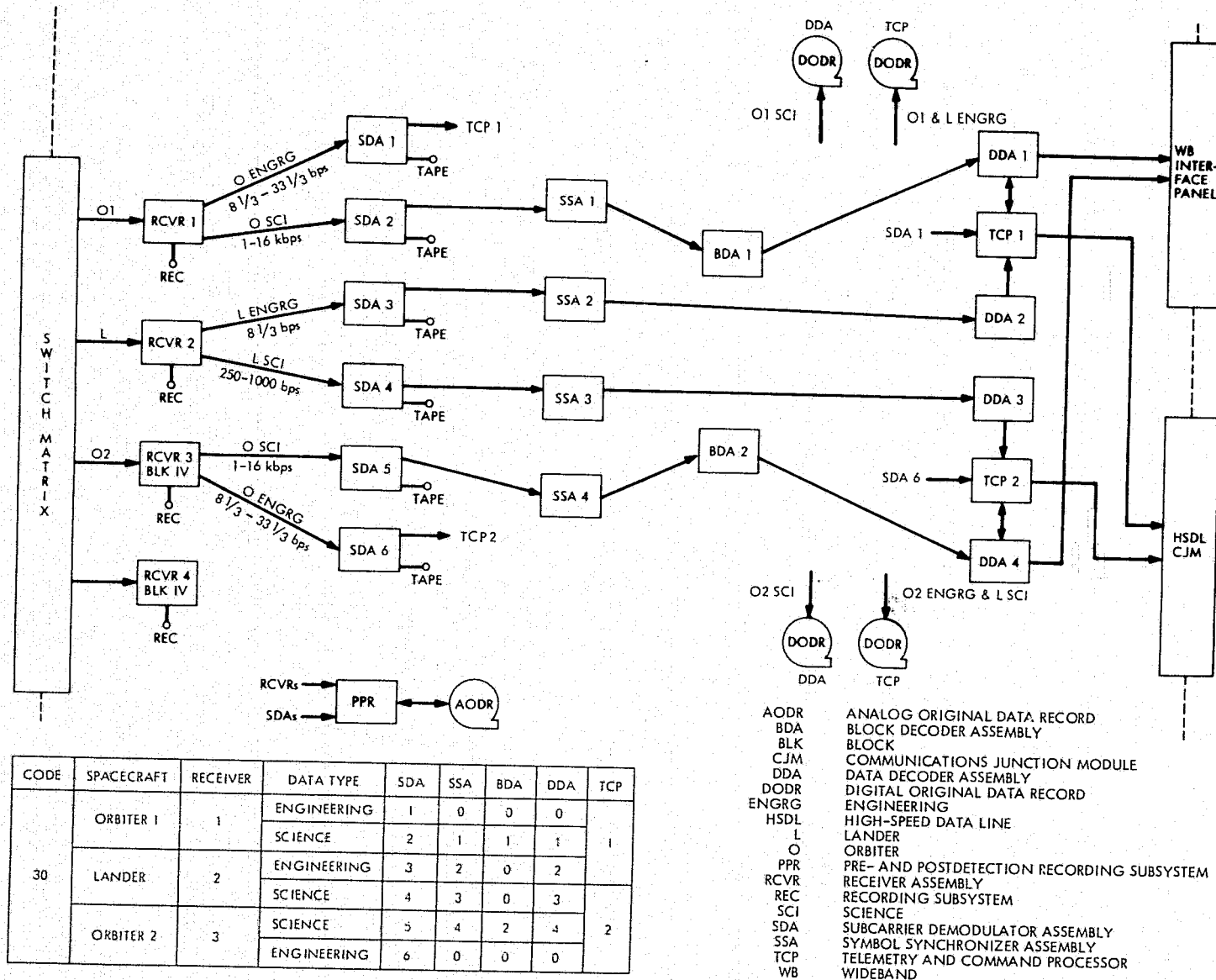

Fig. 15. Standard planetary configuration, Orbiter/Lander Orbiter, Code 30

III. TRACKING AND DATA ACQUISITION SYSTEM

A. INSTITUTIONAL

To support the Viking mission to Mars, the Tracking and Data System requires the capability of acquiring telemetry data simultaneously from two Viking Orbiters and one Viking Lander (including one high rate data stream and one low rate data stream from each vehicle) while commanding and tracking any two of the vehicles. This function is carried out by an operationally unified set of command, tracking, and data acquisition resources composed of a selected collection of Earth-based equipment, software, personnel, and procedures.

The required Tracking and Data Acquisition resources are provided by organizations under the Department of Defense, Goddard Space Flight Center, Kennedy Space Center, Jet Propulsion Laboratory, and referred to collectively as the Tracking and Data System Support Agencies. Although these support agencies are not under the direct control of the System Manager, they are responsive to his needs through a system of communication, coordination, and documentation.

For convenience in planning and management of the resources involved, the support for flight projects is considered in two phases; namely, the near-Earth phase and the deep space phase.

The near-Earth phase begins at lift-off and continues until two-way acquisition of the spacecraft by the first station of the Network immediately following spacecraft separation from the launch vehicle.

The deep space phase begins at this point and continues through the end of mission.

The Viking Project requirements and Network support are formally specified in two National Aeronautics and Space Administration documents, the Support Instrumentation Requirements Document and the National Aeronautics and Space Administration Support Plan. The Support Instrumentation Requirements Document is prepared by the Viking Project Office and the National Aeronautics and Space Administration Support Plan is prepared by the Deep Space Network with review and approval in the National Aeronautics and Space Administration Office of Space Science and the Office of Tracking and Data Acquisition respectively. For the Viking 1975 mission, the Support Instrumentation Requirements Document (RD-3713008, initial issue July 1, 1971, Revisions A - C, September 17 - November 30, 1973, Revision D, April 26, 1974, Revision E, May 31, 1974, Revision F, October 25, 1974, Revision G, April 4, 1975, and Revision H, May 13, 1975) and the National Aeronautics and Space Administration Support Document (initial issue May 1, 1972, Revision 1, September 15, 1974, and Revision 2, July 15, 1975) followed this pattern.

The formal statements of requirements and commitments were preceded by more informal and general descriptions of project plans and system capabilities. Requirements were generalized at the highest level in the Viking Project Plan, which constitutes the general technical/management agreement document for all project and system-level elements of Viking. A predecessor to this document was the Viking Project Specification, approved in May 1970, which levied brief and general requirements on all systems of the Project.

The Network response to the Project Specification and other statements on the need for Tracking and Data System support by Viking was contained in the Tracking and Data System Estimated Capabilities for Viking, initially issued September 1, 1970, and revised thereafter. This document defined the System function and organization, particularized the existing and anticipated support elements applicable to the specified Viking mission, and estimated support and performance capabilities.

As the planning process proceeded, the requirements for support on the one hand, and the capabilities of system elements on the other, came to be progressively better defined, until they could be negotiated and formally stated. Naturally, the nature and distribution of capabilities of the Tracking and Data System institutions influenced the form and to some degree the character of the Viking Project's requirements, though in large part these arose from the defined mission (summarized in Section II). In similar part, the requirements, anticipated and expressed, for Viking support conditioned plans for the evolution of capability, particularly the implementation of the full 64-meter subnetwork of Deep Space Stations and 400-kW high-power transmitter capability.

The Support Instrumentation Requirements Document and the National Aeronautics and Space Administration Support Plan documents constituted the culmination of the institutional planning process, providing between them the negotiated agreement for Tracking and Data System support in the prelaunch, near-Earth, and deep-space phases of the Viking revision.

The requirements and commitments expressed therein are summarized in the following Planning (B) section.

B. PLANNING

1. Pre-Project Planning

Viking Mission planning and studies were in progress before the formal agreement for tracking and data acquisition support was executed in March 1969 between the Langley Research Center and the Jet Propulsion Laboratory. A year previously, planning started at Langley, while advance studies at the Laboratory preceded the agreement by six months. The System estimated capabilities were published December 1, 1968, three months ahead of agreement execution.

Despite the later schedule and organizational changes, Project and the Network preplanning studies provided a good approximation of the final support requirements and planning. This was especially true in the Estimated Capabilities document. The extreme Viking demands stemmed from the duration of the critical operations period, density of coverage, and the number of spacecraft to be tracked and commanded independently and simultaneously. The nature of the mission called for high navigation-accuracy requirements. Telemetry data requirements were significantly greater than those of ongoing planetary projects. This was a result of more complexity because of the number of spacecraft involved simultaneously, and because the primary mission objective was conceived to be more critical. Command requirements were critical, especially during planetary operations. Interesting problems were presented by the necessity of operating the Lander on the surface under severe geometrical constraints posed by a rapidly rotating planet. Viking planning was soon predicted on the then future availability of an advanced (64-meter) antenna subnetwork to supplement the two existing 26-meter antenna subnetworks.

Prior to the formal authorization of the Viking 73 Project, the basis for Tracking and Data System support planning consisted of informal data describing anticipated mission requirements, the current capabilities of the Deep Space Network and the existing near-Earth support capabilities together with the development potential of the Network, as well as some considerations of future mission loading on the Network.

The mission loading study, documented some months later in the light of defined support requirements (Ref. 1), showed in the expectation of considerable mission activity requiring Network support in the Viking mission period. However, estimation was that Viking requirements as understood could generally be met. Completion of the 64-meter subnet in time to support Viking was clearly required, as were development and growth in all Network data systems. In addition to the Viking missions considered, Network loading studies included the existing interplanetary Pioneers, the Jupiter Pioneers (F and G, later 10 and 11), the Venus/Mercury 1973 swingby (later Mariner 10), the Helios solarprobe missions, and Mariner Mars 1971. A number of potential planetary missions also were considered.

2. Planning the 1973 Mission

Following formal approval of the Project, in February 1969, System planning continued without hiatus. Assumptions were not essentially changed by the formal start of Project work, the execution of the management agreement covering Viking Tracking and Data System support, and the buildup of Project management and contracting that ensured. A preliminary Master Working Schedule for Viking support planning and implementation was completed in May. Completion of the 64-meter subnet was carried forward with the selection of a prime contractor in July; this effort had been scheduled to be compatible with Viking 1973 support requirements.

Detailed analysis of launch-phase characteristics showed the need for a thorough study of near-Earth requirements, with improvements in downrange coverage. This effort was undertaken in late 1969.

It was foreseen that planetary operations would require both Viking Orbiters to operate simultaneously with one Lander at a time requiring the support of three Viking spacecraft at Mars at the same time. Additional complications in planning deep-space support were caused by the complexity of Viking responsibilities with Project at the Langley Research Center, the Deep Space Network and Orbiter at the Jet Propulsion Laboratory, and Lander at Martin Marietta Corporation. To meet the challenge of these complex institutional interfaces, the Viking Project office established a Viking Management Council. The Council was expected to provide a top level forum for the resolution of interagency problems that might otherwise inhibit working relationships at the technical level.

A Network Capabilities Planning Team was organized at Jet Propulsion Laboratory in November 1969 to plan and study Viking Tracking and Data System support capabilities and requirements in the light of project long-range capabilities and plans of the Network. A Network readiness date of January 1, 1973, was targeted as a Viking Project requirement. However, two months later the schedule basis of this planning effort was shifted by the change in Viking launch plans.

The planning activities during this period were reported in Refs. 1, 2, and 3.

3. Planning the 1975 Mission

While the Project was developing a new mission plan resulting from the rescheduling of the launch to 1975, the Network used the opportunity to prepare a general Interface Design Handbook and identify the Viking interfaces. The Project Office issued the Viking '75 Project Specification in May, and the choice of flight trajectories was made in July. In addition, the study of launch-phase coverage problems was continued and updated to accommodate conditions of the 1975 launch period; this effort was completed in September.

Meanwhile, construction work continued in Spain and Australia on the 64-meter antenna tracking stations. These were to be conjoined with the 26-meter antennas using common control and communications facilities, for economy and flexibility.

Estimated capabilities and the interface designs were updated to take into account the new requirements of the 1975 mission, and released in the Fall of 1970. By this time, it had been recognized that the Viking 1975 flight geometries, in conjunction with practical Network capabilities and Viking requirements, posed real constraints on some aspects of support. The angular separation during cruise of the two Viking spacecraft precluded dual tracking with a single

64-meter antenna until a few days before Mars arrival of the second spacecraft. The extreme range at Mars arrival (300 million km) and its increase (to 400 million km) imposed limits on telemetry rates, while the proximity of solar conjunction to Mars operations constrained Viking planetary operations by affecting communications signal parameters beginning in October 1976.

The installation of a 400-kW transmitter was planned for Goldstone, while the overseas 64-meter stations were to have 100-kW transmitters. Studies of the capability of maintaining dual command links from a single 64-meter antenna at various power levels were undertaken. This capability would be required to allow the 64-meter subnet to provide separate command coverage of planetary operations of the first Orbiter and Lander while the second Orbiter and Lander were still approaching Mars. These studies eventually showed that risk of interference to the telemetry carrier from intermodulation products due to dual carriers required the use of a second subnet (26-meter) for simultaneous commanding of two spacecraft.

Further, during this period, great attention was given to consideration of the metric data accuracy and the special navigation requirements of the mission. Project requirements for metric data quality were understandably stringent, and stressed Network capabilities in this area to the limit of the state of the art at that time.

Another area of concern during this period was the coordination of management and planning documentation between the Viking Project and the Deep Space Network. Configuration management and data management negotiations were successfully concluded to assure that Project needs would be met through the use of Network practices, and key interface planning tasks were assigned to a number of specialist Working Groups, as well as a joint Network Interface Team and the Capabilities Planning Team, whose operations were suspended at the time of the Viking schedule redirection and reinstated in September, 1971. Good communications were maintained by these groups through frequent meetings and a rigorous assignment and closeout of action items and documentation. These efforts are reported in Ref. 4.

The preparation of Support Instrumentation Requirements Documents and the National Aeronautics and Space Administration Support Plans began in mid-1971 with the preparation and Project Office approval in July of the Support Instrumentation Requirements Document. A preliminary National Aeronautics and Space Administration Support Plan was circulated for review in October 1971.

In July 1971, reorganization changed the configuration of the Tracking and Data System. At Jet Propulsion Laboratory, a new Office of Computing and Information Systems was established to take responsibility for the new Data System Division and for Data Processing Requirements. By December, the Space Flight Operations Facility had been completely transferred from the Tracking and Data Acquisition Office to the new office. In the meantime, National Aeronautics and

Space Administration (NASA) separated the support and management of computing systems and data processing from the Headquarters Office of Tracking and Data Acquisition. As a result of these changes, a new Viking Mission Control and Computing Center System was created to take responsibility for mission computing and data processing services. The task of supporting the Project with data processing and display facilities ceased to be a Tracking and Data System responsibility.

A revised Support Plan was prepared by the Network and approved at Jet Propulsion Laboratory in May and by the NASA Headquarters in June 1972.

The Compatibility Test Area 21 was ready to support Viking in July 1972 although compatibility testing did not begin until January 1973. The 64-meter antennas at Station 43 in Australia were accepted from the contractor in July 1973 and the 64-meter antenna in Spain, Station 63, was accepted in January 1974.

By February 1973, tests of the dual-command-carrier mode had been completed at Goldstone, and this mode was dropped from the support plans because of the insoluble problem of intermodulation interference. As a consequence, three subnets were committed to the mission phase in which an Orbiter and a Lander at the planet and another Orbiter-Lander approaching the planet have to be given command coverage. At this time, the first Orbiter-Tracking and Data System compatibility testing was underway. In November, the first new Viking-support hardware, the Block IV receiver/exciter, was installed at Station 14 at Goldstone. The implementation of Viking Tracking and Data System configuration was in progress.

During the same period, the final plans for implementation, testing, and operations were completed and released. The Support Instrumentation Requirements Document was updated (reflecting the new System configuration) and the Network-Control Center interface requirements defined and published. Thus with the beginning of the implementation phase of Tracking and Data System for Viking, the planning phase had been completed. Although key planning documents and schedules would continue to be revised in a minor way to account for implementation evolutions and interactions, Tracking and Data System support for the Viking 1975 mission was understood, integrated, and documented.

C. REQUIREMENTS FOR TRACKING AND DATA SYSTEM SUPPORT

1. Near-Earth Phase

The near-Earth support facilities consisted of resources of the Kennedy Space Center, Air Force Eastern Test Range, Goddard Space Flight Center's Spaceflight Tracking and Data Network, Deep Space Network, and NASA Communications Network.

The purpose was to acquire, record, retransmit, display and process data specified in the Viking '75 Support Instrumentation Requirements Document in accordance with the Viking '75 NASA Support Plan for the Near-Earth Phase of the mission. This phase includes certain perlaunch testing, launch operations, and flight until initial two-way acquisition of the spacecraft by the Deep Space Network.

The real-time retransmission of metric tracking data was to be used for determining orbital parameters, computing acquisition data for the more remote tracking sites (including selected Deep Space Network sites), and establishing early indications of the Mars encounter accuracy of the spacecraft and the separated Centaur stage. The real-time retransmission and display of space vehicle telemetry data, together with the metric tracking data mentioned above, were used to:

- (1) Determine the instantaneous status of the launch vehicle.
- (2) Establish as quickly as possible the normalcy of the mission.
- (3) Aid in project decisions concerning nonstandard events.
- (4) Aid the near-Earth support stations in acquiring the launch vehicle, spacecraft, or both.
- (5) Enable early postlaunch analysis.

The near-Earth tracking system was called upon to support all the mandatory requirements requested for the Viking mission for at least a 50-minute window per day and for most days at least a 60-minute window. However, support for some of the "required" or "desired" requirements could not be provided by the near-Earth support because resources were not available or the signal level was marginal during that interval. After start of Centaur reorientation to the blow down vector, the signal strength of both the radar and launch vehicle telemetry links was expected to decrease. The spacecraft telemetry link at (2295.0 MHz) was not committed between launch and spacecraft separation, because a 40-dB absorber inserted in front of the low gain antenna to protect the spacecraft receiver, permitted only leakage radiation to be available for tracking purposes.

A summary of the near-Earth support system requirements that could not be provided is given in Fig. 16.

2. Deep Space Phase

The Deep Space Network supporting facilities for Viking consisted of one 64-meter subnet, two 26-meter subnets, the prelaunch

M MANDATORY
 R REQUIRED
 D DESIRED

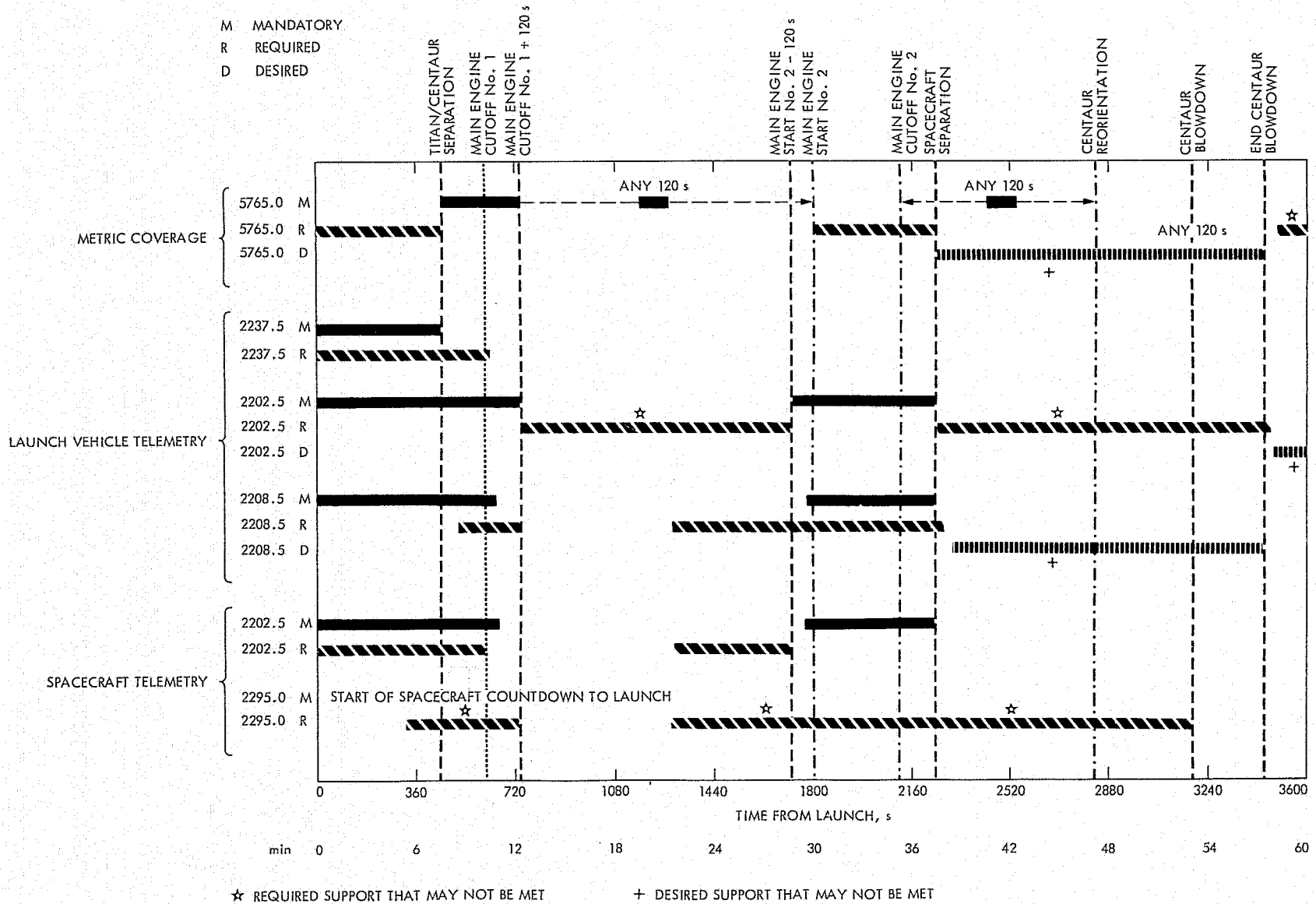

Fig. 16. Summary of near-Earth support requirements that could not be provided

Compatibility Test Area 21 at Jet Propulsion Laboratory, and the launch monitor station at Merritt Island. Ground communications were by voice, teletype, high speed data, and wideband data transmission circuits. Network control, monitoring, and data system validation were provided by the Network Operations Control Center at Jet Propulsion Laboratory. In addition, the Control Center was responsible for producing Intermediate Data Records for telemetry, tracking predicts, seven-day schedules, and sequences of events for the Deep Space Network.

Stations 11, 12 (Goldstone), 42, 44 (Australia), 61, and 62 (Spain) were configured as the primary stations for cruise support until limiting signal conditions required transfer to the 64-meter subnet. The primary stations for Mars operations support were Stations 11, 14 (Goldstone), 42/43 (Australia), and 61/63 (Spain). However, if telemetry communications requirements exceeded the capability of the 26-meter subnet shortly after launch, the 64-meter stations were required to provide the necessary telemetry support. Full planetary ranging capability was the responsibility of Stations 11, 14, 43, and 63. Telemetry and command data were to be received and processed as required. Prelaunch compatibility test requirements were to be met. The gross periods of commitment for the three subnets, and the compatibility test stations are given in Fig. 13 with the weekly coverage in Tables 2 and 2A.

The Deep Space Network, Ground Communication Facility, and NASA Communications Network were to provide voice, high speed data, wideband, and teletype circuits required for the transmission of command, telemetry, tracking, simulation, monitor, and operations control data between the control centers and the stations. Communications capability was required to correspond to the Deep Space Station capability to support all combinations of Viking data streams. However, maximum communications circuit loading under all conditions of combined testing/training/flight support was not to exceed eight high speed and two wideband data channels. Communications capability for simultaneous transmission from two stations during overlap coverage periods was to be provided as required. Ground Communications Facility and NASA Communications support for the deep space phase was to begin approximately launch plus six hours and extend through end of mission (15 November 1976) as shown in Fig. 17.

Capability was to be provided for generating Network simulation data, as well as accepting a simulated command-responsive telemetry data stream from the Project.

The Network Operations Control Center was to provide for control and monitoring of Network performance. All incoming data were to be validated at this point while being simultaneously transferred to the Mission Control and Computing Center for real-time use by the Flight Operations System. Any missing or bad telemetry data were to be

recalled from the Digital Original Data Record at the tracking stations. These data were to be time merged with the real-time telemetry data contained on the Network Data Log to form a Telemetry Intermediate Data Record. This capability was scheduled to be operational February 1, 1976. The capability to recall and replay telemetry data from the Digital Original Data Record via high speed/wideband data line to the Mission Control Center was to be provided both before and after implementation of the Intermediate Data Record capability. The capability to recall and replay command/tracking data from the command/tracking Digital Original Data Record was to be provided.

Network planning assumed that elements of the 26-meter subnet (Table 7) were to be used to provide back-up capability for the 64-meter subnet in the event of failures from which rapid recovery at the affected 64-meter Deep Space Station was not otherwise feasible. The Project was expected to recognize these factors in its mission design activities, particularly during critical sequences of the mission.

In response to Project requirements, the Network implementation plan provided for all major hardware and software necessary to reconfigure the Network for Viking, to be on site, including overseas sites (Fig. 18, 19, and 20), prior to launch. However, system testing of all hardware and software in the planetary configuration was not scheduled to take place at the overseas sites until November/December 1975.

3. Unsupported Requirements

In general, the Tracking and Data System was able to provide tracking and data acquisition resources to satisfy all Viking requirements. They had been defined on the basis of known and anticipated near-Earth and deep space capabilities and facilities, and on the feasibility of such commitments.

There were, however, three other factors that influenced the System's ability to satisfy all its commitments to the Project: unforeseen changes in support provided by other agencies outside the jurisdiction of National Aeronautics and Space Administration, uncertainties of advanced development technology, and the needs of other missions.

During the near-Earth support planning phase, the station at Carnarvon was decommissioned and the station at Tananarive was closed. This forced greater reliance on Advanced Range Instrumented Aircraft and the instrumented ship Vanguard to fill gaps and extend coverage. However, the changes resulted in no compromise to near-Earth support of the Mission.

It had been anticipated early that dual command carriers could be maintained from a single 64-meter station, using the high-power transmitters then being planned. This strategy permitted the requirement of constant readiness to command two spacecraft to be met, using

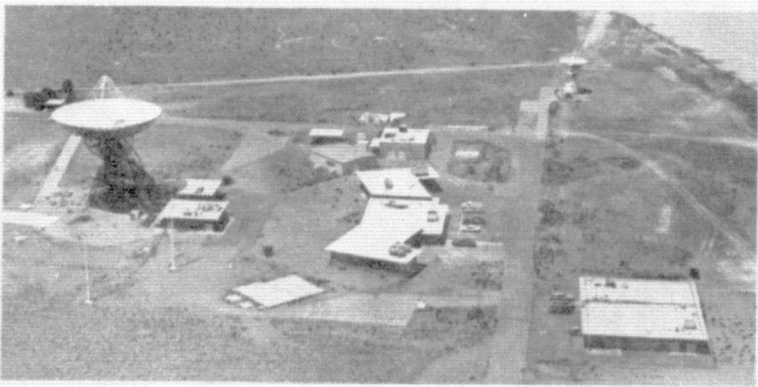
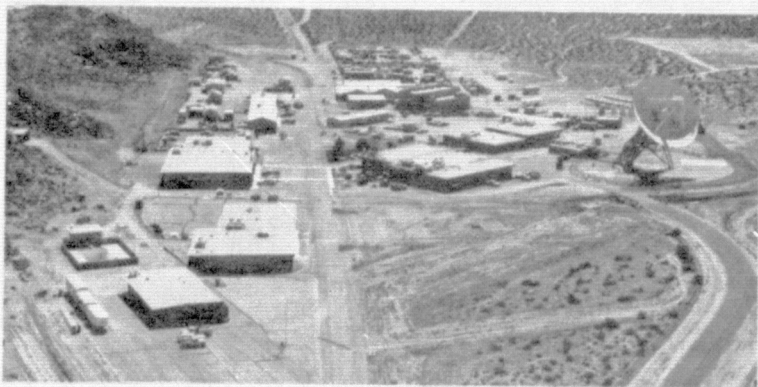

Fig. 18. Goldstone, California, Deep Space Stations: 11 (bottom), 12 (center), 14 (top)

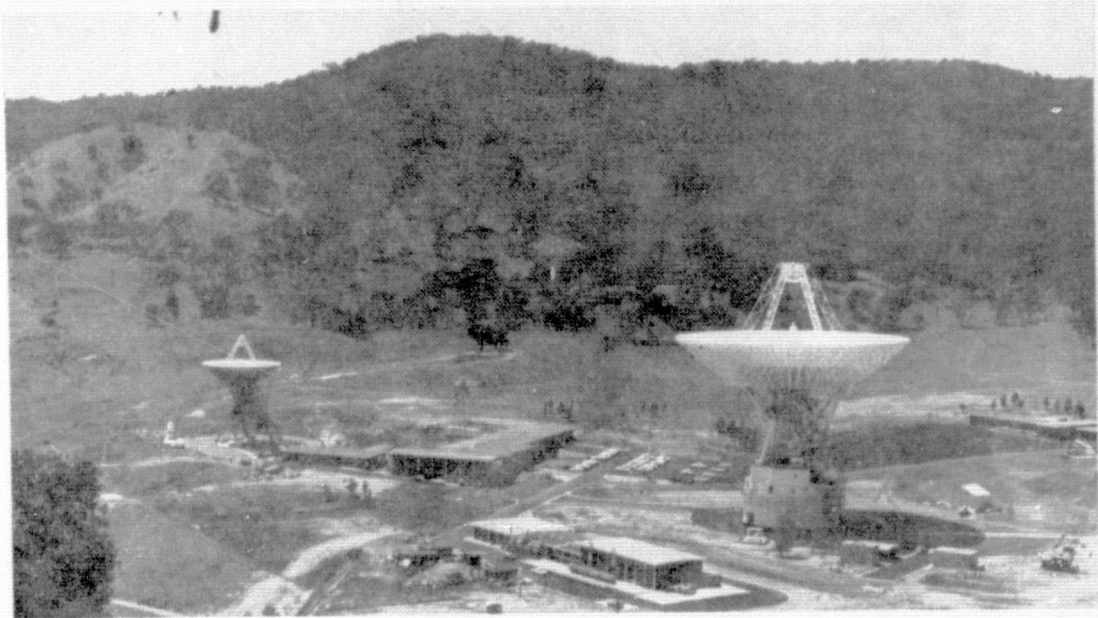
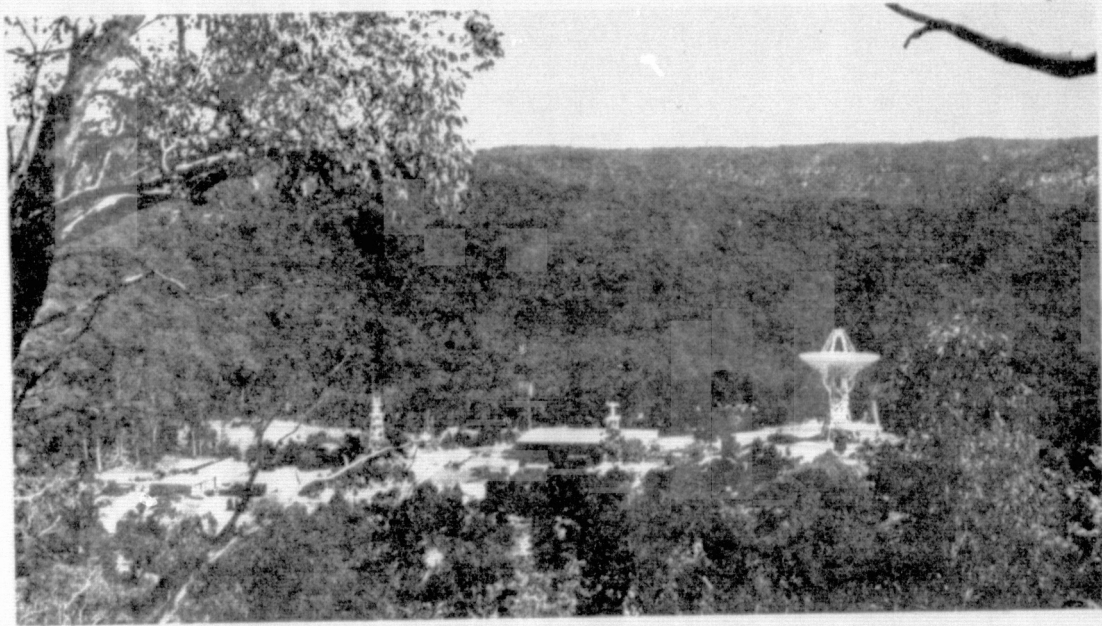

Fig. 19. Deep Space Stations 42 and 43 (bottom), and 44 (top), near Canberra, Australia

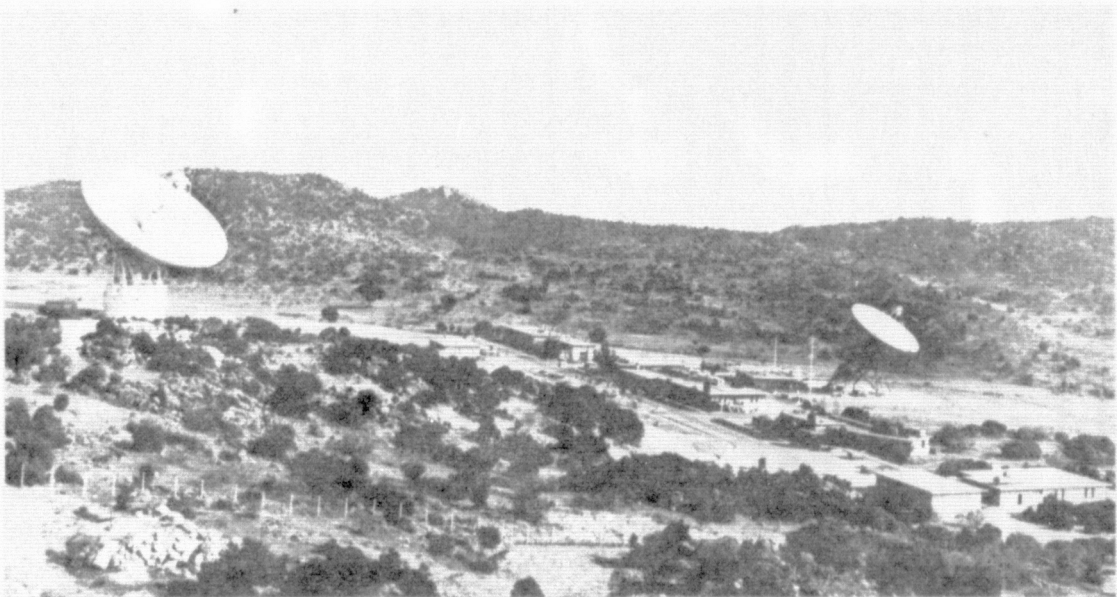

Fig. 20. Deep Space Stations 61 and 63 (bottom), and 62 (top) near Madrid, Spain

Table 7. Tracking and data acquisition stations of the Deep Space Network

Deep Space Communications Complex	Location	Deep Space Station	Station serial designation	Antenna		Year of initial operation
				Diameter m (ft)	Type of mounting	
Goldstone	California	Pioneer	11	26(85)	Polar	1958
		Echo	12	26(85)	Polar	1962
		Mars	14	64(210)	Az-El	1966
Tidbinbilla	Australia	Weemala	42	26(85)	Polar	1965
		Ballima	43	64(210)	Az-El	1973
-	Australia	Honeysuckle Creek	44	26(85)	X-Y	1973
Madrid	Spain	Robledo	61	26(85)	Polar	1965
		Cebreros	62	26(85)	Polar	1967
		Robledo	63	64(210)	Az-El	1973

54

33-783, Vol. I

REPRODUCIBILITY OF THE ORIGINAL PAGE IS POOR

the 64-meter subnet for the case in which the two spacecraft were close enough to be illuminated by one antenna (as when both are at or near Mars). However, extended development work and testing uncovered some difficulties, both with the high transmitter powers planned and with intermodulation products induced on the surface of the antenna under dual carrier conditions. It was, therefore, decided to install 100-kW transmitters at the overseas 64-meter sites, with an experimental 400-kW transmitter at the Goldstone site, and to regard dual-carrier commanding only as a mission enhancement option. This led directly to a requirement for two stations to provide two simultaneous uplinks. A third station was required to support the second spacecraft prior to its arrival at the planet.

Concurrent deep space missions included the interplanetary Pioneers (6 - 9), post-Jupiter operations of the Jupiter Pioneers (10 and 11), and Helios (A and B). The Helios B launch, January 1976, and near-Solar operations three months later appeared to be the only critical operations of other Projects that were contemporary with Viking flight operations. Angular separation generally afforded relief from many potential conflicts between Viking and other Missions supported by the Network, while schedule separation relieved launch-support conflicts. Numerous differences between requirements stated in the Support Instrumentation Requirements Document and commitments given in the NASA Support Plan remained for subsequent negotiation and resolution in the iterative process. Ultimate convergence was reached only in the course of operations.

D. MANAGEMENT

1. Schedules

The approach to schedule management for the Viking reconfiguration activities in the Network was based on a family of schedules starting with the Tracking and Data System Level 3 and proceeding down through Levels 4 and 5 to individual Station implementation and test periods.

At Level 3, only major milestones representing Tracking and Data System interaction with other systems of the Viking Project were identified. This schedule also included activities for the preparation of near-Earth support. The Level 3 schedule was updated monthly and published by the Viking Project Office, along with similar schedules for the other systems of the Project in Viking Project Working Schedules and Reports. A typical page from this document is shown in Fig. 21.

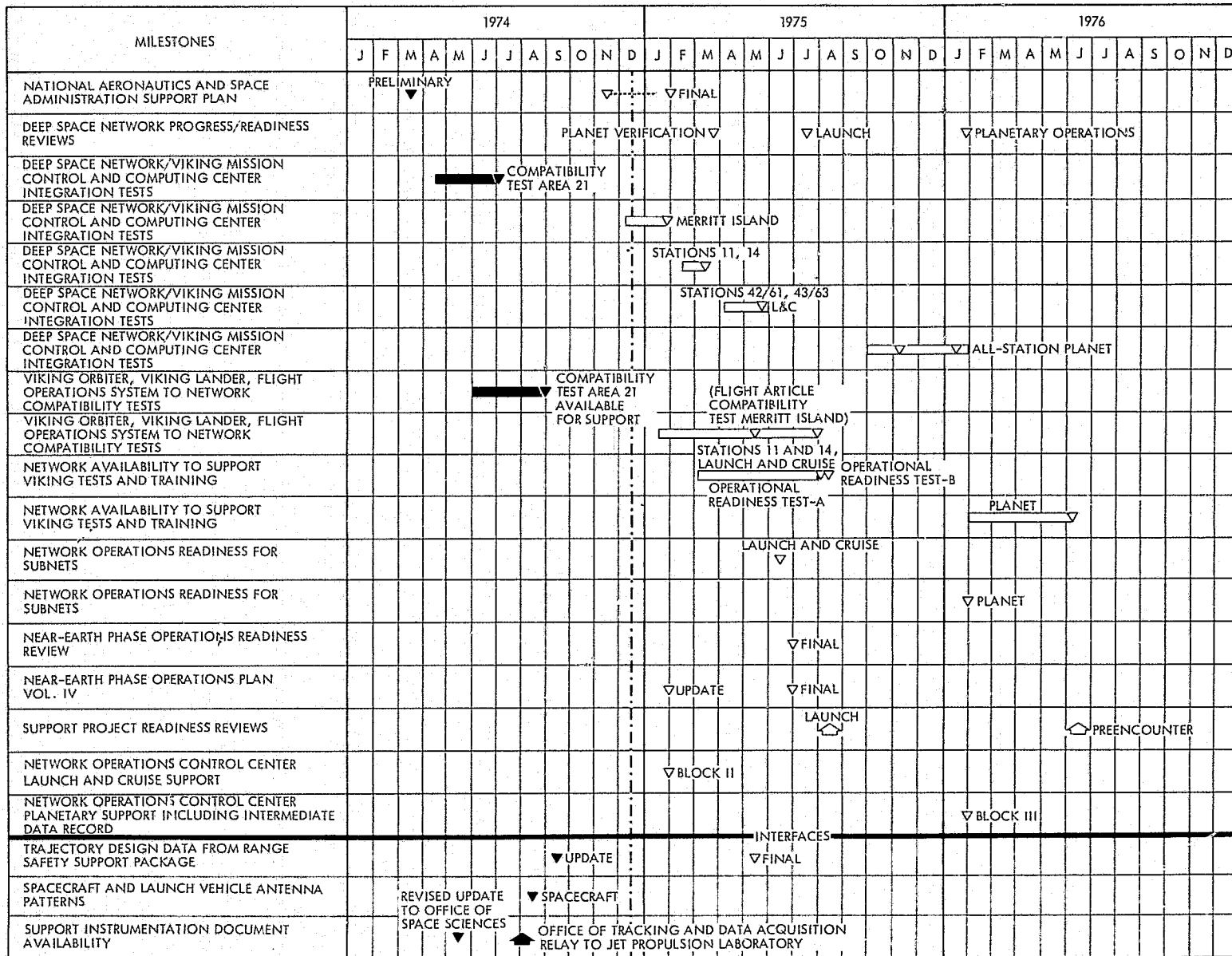

Fig. 21. Extract from Tracking and Data System Schedule, Level 3, for November 1974

The next set of schedules shows activity necessary at each Station to meet the key milestones in Level 3. This, too, was updated monthly, in accordance with progress at each Station and reported in the Viking Project Office for publication in the same document as the Level 3 schedules. A typical sheet for Stations 11 and 14 for November 1974 is shown in Fig. 22.

At this point, it became necessary to identify implementation and test activity at the Station subsystem level. For this purpose, a series of Level 5 schedules was developed. At Level 5, the required readiness dates for all Station subsystems were shown together with the ensuing testing and training activities.

As in all the other schedules, the key dates needed to meet the committed Viking Project readiness dates were carried forward. These schedules were internal Network documents and were distributed to the Project for information and to the stations and the implementation, test, and operations organizations as a basis for their own subtier planning.

The published document was called the Viking Implementation Schedule and a typical page for Station 14, November 1974 is shown in Fig. 23. This document was updated monthly from the data provided by the Deep Space Network Implementation Schedule.

However, potentially serious difficulties faced Network management by November 1974. These were created by overload of contributing organizations, preoccupation with preceding in-flight project problems and demands, and the number of different organizational boundaries involved. Overall magnitude of the task compounded the problems.

2. Engineering Change

In October 1974, Station 14 (Goldstone) was out of service for approximately one month to reconfigure for the approaching Helios A launch, Pioneer 11 Jupiter encounter, and to include a substantial number of the engineering changes necessary to meet the Viking configuration published in Ref. 5.

At the conclusion of this work, it was intended to start Viking System Performance Testing in accordance with the foregoing schedules and plans. After several futile attempts to accomplish this work it became apparent that there was an urgent need for better visibility and control of the multitude of Engineering Change Orders needed to supplement the implementation of the subsystems before full system performance testing could begin.

Further investigation soon revealed that the Engineering Change Orders needed for the other stations in the Network were not clearly

MILESTONES	1974												1975												1976											
	J	F	M	A	M	J	J	A	S	O	N	D	J	F	M	A	M	J	J	A	S	O	N	D	J	F	M	A	M	J	J	A	S	O	N	D
RECEIVER/EXCITER SUBSYSTEM																																				
RECEIVER/EXCITER BLOCK IV																																				
SUBCARRIER DEMOD ASSEMBLY																																				
X-BAND OPEN-LOOP RECEIVER MODS																																				
RANGING DEMODULATOR ASSEMBLY																																				
DSN SYSTEM PERFORMANCE TESTS																																				
TELEMETRY																																				
COMMAND																																				
TRACKING																																				
TEST AND TRAINING																																				
MONITOR AND OPERATIONS CONTROL SYSTEM																																				
MISSION PREPARATION TESTING																																				
DEEP SPACE NETWORK/VIKING MISSION CONTROL AND COMPUTING CENTER SYSTEM INTEGRATION																																				
OPERATIONAL VERIFICATION																																				
PERFORMANCE DEMONSTRATION																																				
CONFIGURATION VERIFICATION																																				

Fig. 23. Extract from Goldstone Station 14 Milestone Schedule for November 1974

understood, and in many cases, were not scheduled properly to mesh with the subsystem need dates reflected in the Level 5 schedules. This implied a serious risk to the Network's ability to meet the Viking need dates.

At this point (November 1974), upper management attention was drawn to these potential difficulties, created to a large extent by the magnitude of the job involved, overloading of contributing organizations and preoccupation with preceding in-flight project problems, and the number of different organizational boundaries involved. A prompt response resulted in the establishment of a three-man task team charged to:

- (1) Identify all the engineering changes involved.
- (2) Select those essential to the Viking configuration.
- (3) Classify the essential changes according to categories of readiness.
- (4) Take all action necessary to expedite any of these latter changes that might delay the readiness dates.
- (5) Establish a frequent and regular reporting and management system at the change order number level.

The way in which the team was to work is shown in Fig. 24.

The Telecommunications Division was to compile the list of essential engineering changes to permit the Station directors to estimate subsystem readiness dates. Combined with data for the Mission Configuration Tests and the Operational Verification Tests, management could determine whether the Viking need dates could be met.

Where these dates could not be met, it became necessary to further reduce the test time (Organization 420), expedite the engineering changes (Telecommunications Division), or renegotiate the Project need dates with the Viking Project Office. As this work proceeded, all three approaches became necessary. The outcome of several iterations of this process had resulted in the Network readiness summary shown in Table 8.

Further iterations were in progress to improve the schedule deviations to allow for contingencies that may arise in progress. Plans were made for a computer-based change status reporting system using the following data sources as input:

- (1) Data from the Engineering Division regarding engineering change kit deliveries to the cognizant operations engineers.

Table 8. Network readiness summary

Station	Readiness category ^a	Start date	Total hours	Ready date	Project need date	Schedule deviation (Weeks from 12/3/74)
14	A/B	11/15/74	499	2/24/75	2/10/75	- 2 ^b
	C	11/15/74	92	2/15/75	6/9/75	+ 11
	F	2/1/75	615	10/15/75	11/3/75	+ 2
43	C	2/1/75	237	4/1/75	4/7/75	+ 1
	D	4/1/75	198	7/1/75	8/1/75	+ 4
	F	12/1/74	775	11/5/75	1/5/76	+ 8
63	C	2/1/75	237	4/1/75	4/28/75	+ 4
	D	4/1/75	198	7/1/75	8/1/75	+ 4
	F	1/15/75	775	10/1/75	1/5/76	+ 12
11	A/B/C/F	1/15/75	167	2/21/75	2/24/75	0
42	C/F	2/1/75	177	3/7/75	4/7/75	+ 4
61	C/F	2/1/75	177	3/7/75	4/28/75	+ 7

^aCategories of readiness:

- A Support planetary verification tests (telemetry and command)
- B Support planetary verification tests (tracking and monitoring)
- C Support launch phase system integration tests
- D Block IV receiver committed at stations 43 and 63
- F Support planetary phase system integration tests

^bReady date exceeds need date.

NOTES:

Maximum mission configuration test rate is 10 hours per test, 2 tests per week.

Maximum operational verification test rate is 6 hours per test, 2 tests per week for two weeks, prior to need date. Remaining Operational Verification Tests are in parallel with system integration tests.

Station hours for Engineering Change Orders that are not subject to Mission Configuration Tests or Operational Verification Tests are not included in these estimates.

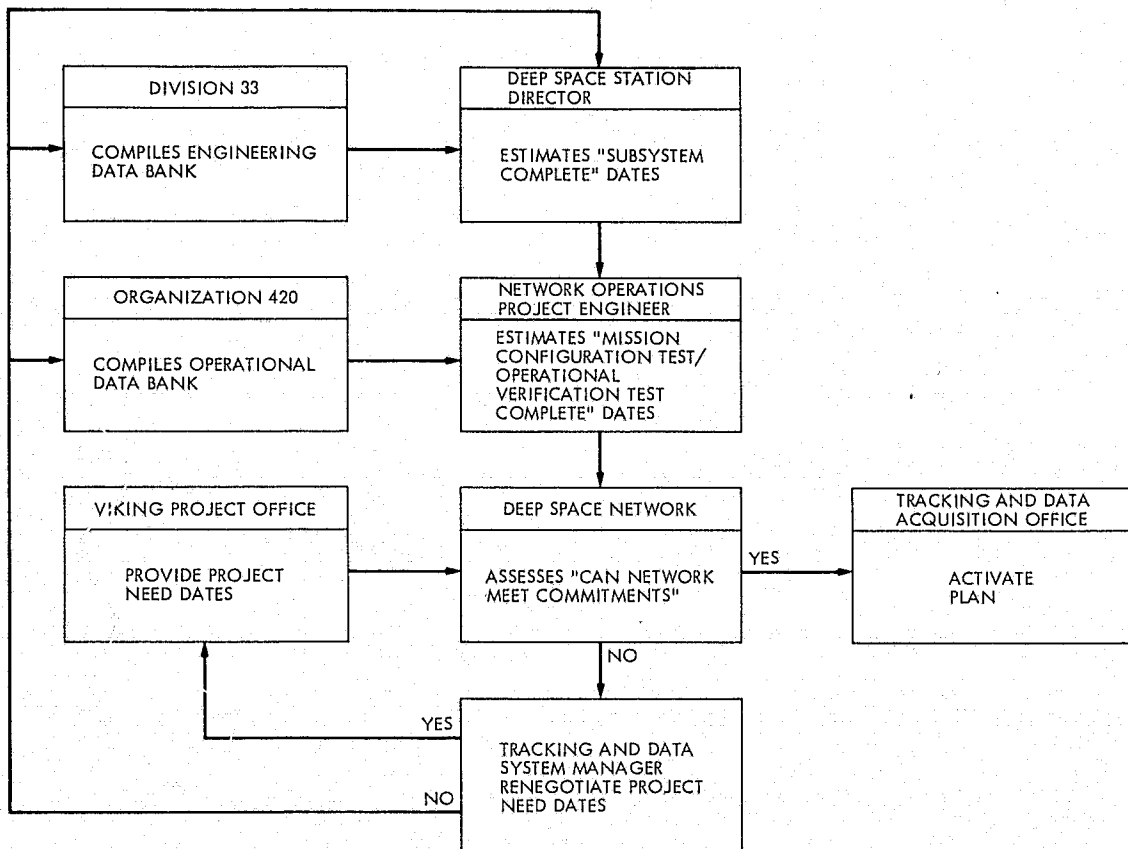

Fig. 24. Engineering change planning for Viking

- (2) Data from the cognizant operations engineers regarding shipping and delivery of the modification kits to the stations.
- (3) Data from the station directors regarding implementation at the stations.

It was planned to have this status reporting system in operation by mid-January 1975.

It soon became apparent that with the large number of engineering changes involved in implementing the Viking configuration (approximately 400), the number of stations involved (nine, plus Compatibility Test Area 21 and the Merritt Island Station), and the number of steps required to complete each Engineering Change Order (about 12), that a large computer based system would be required to properly manage the entire process, to track the status of each order, and to provide the detailed status reporting required by the Viking Project.

A monumental software programming task was undertaken by members of the Tracking and Data Acquisition office in December 1974 and January 1975. The result was the formal presentation of an Integrated Implementation and Test Schedule to the Viking Project at a Status Review on January 27, 1975. This document contained all the milestones for each Engineering Change Order for all the stations, including Merritt Island and the Network Operations Control Center, from the time of issue through completion of the Planetary Configuration in February 1976. It was to be published monthly and updated by terminal inputs to the Univac 1108 computer files as each cognizant engineer completed the change order milestone for which he was responsible. The Network Control Center inputs were rather neglected because, being a new implementation project, it was not at this time controlled or managed by the engineering change management process. This deficiency subsequently proved to be a costly and embarrassing oversight. The document, which came to be colloquially referred to as the "Dobiesked," continued to be issued regularly until August 1975. Then, having served its purpose, it was discontinued in favor of the Engineering Change Request Status Reporting System.

This Status Reporting System, which was used to complete the planetary configuration for Viking, came into extensive use after the Viking launches and therefore is detailed in Volume II of this series.

3. Documentation

A basic premise of the Viking Project management approach was that the difficulties introduced by the multiplicity of institutions and organizations — government, industry, and academic — and their dispersion throughout the entire country would be ameliorated to a large extent by a detailed, comprehensive and well organized documentation and reporting system. This approach became evident at the outset of the functioning of the Project and the basis for the final documentation system that had been established by the end of 1968.

Over the following years, the original documentation tree underwent many alterations. These came partly as a result of experience and improved understanding of the management problems to be dealt with, partly as a result of changes in the structure of the Project itself, and finally, because of changes in the personnel and the consequent difference in working arrangements.

By mid-1974, the documentation tree had reached its final form and the issue for January 1975 is shown in Fig. 25.

The burden imposed on the Tracking and Data System by direct responsibility for many of these documents is shown by the listing that follows:

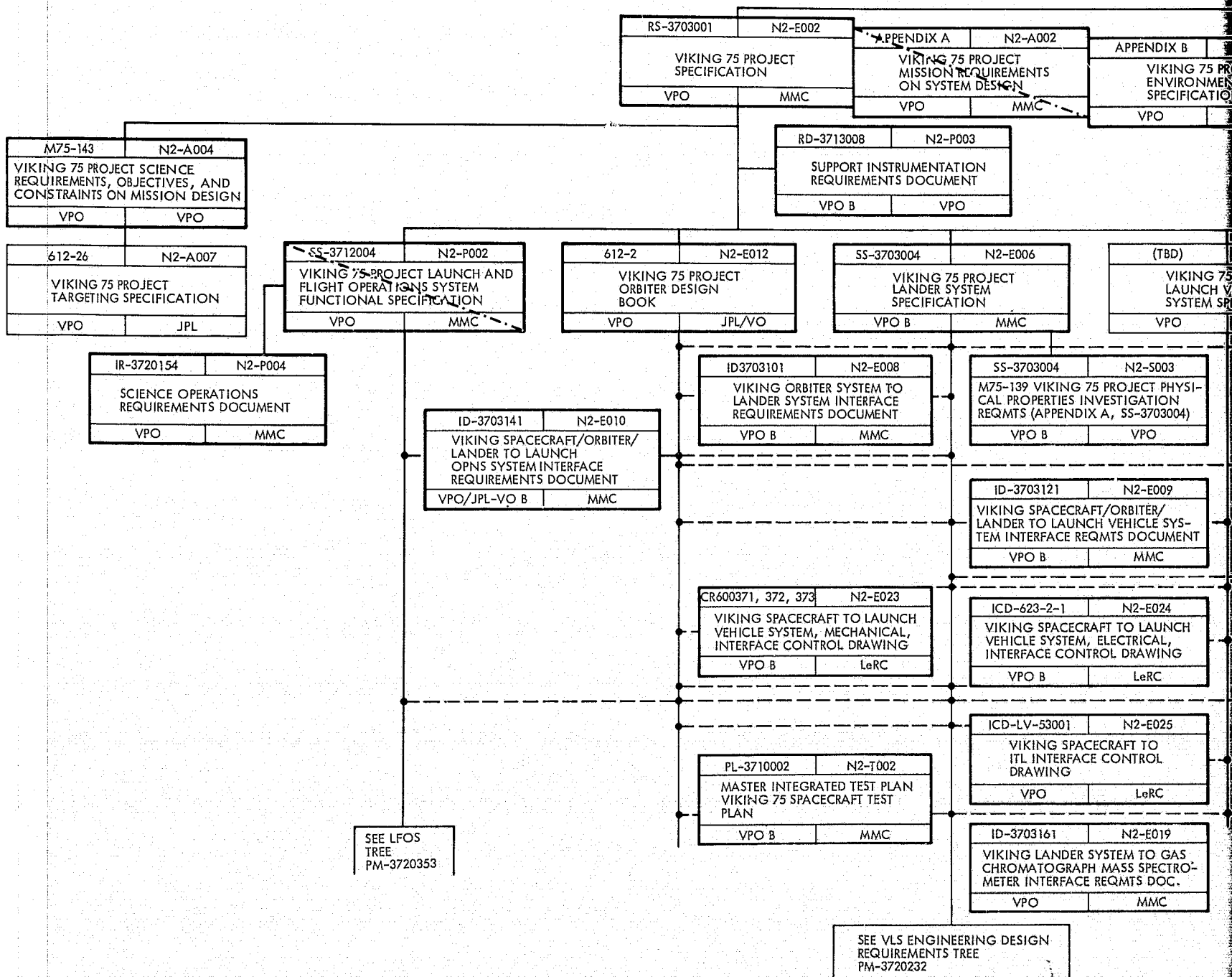

FOLDOUT FRAME

815	N2-M008
PROJECT APPROVAL DOCUMENT	
NASA	NASA
M75-131	N2-M009
VIKING PROJECT PLAN	
NASA	NASA

N2-A002	APPENDIX B	N2-E005	APPENDIX C	N2-E007	APPENDIX D	N2-A003	APPENDIX E	N2-S002	APPENDIX F	N2-S004
PROJECT REQUIREMENTS DESIGN	VIKING 75 PROJECT ENVIRONMENTAL SPECIFICATION		VIKING 75 PROJECT SPACECRAFT STRUCTURAL DESIGN CRITERIA		M75-123 VIKING 75 PROJECT MISSION DEFINITION		M75-125 MARS ENGINEERING MODEL FOR VIKING PROJECT		M75-140 VIKING 75 PROJECT RADIO SCIENCE INVESTIGATION REQUIREMENTS	
MMC	VPO	MMC	VPO	MMC	VPO	VPO	VPO	VPO	VPO	VPO

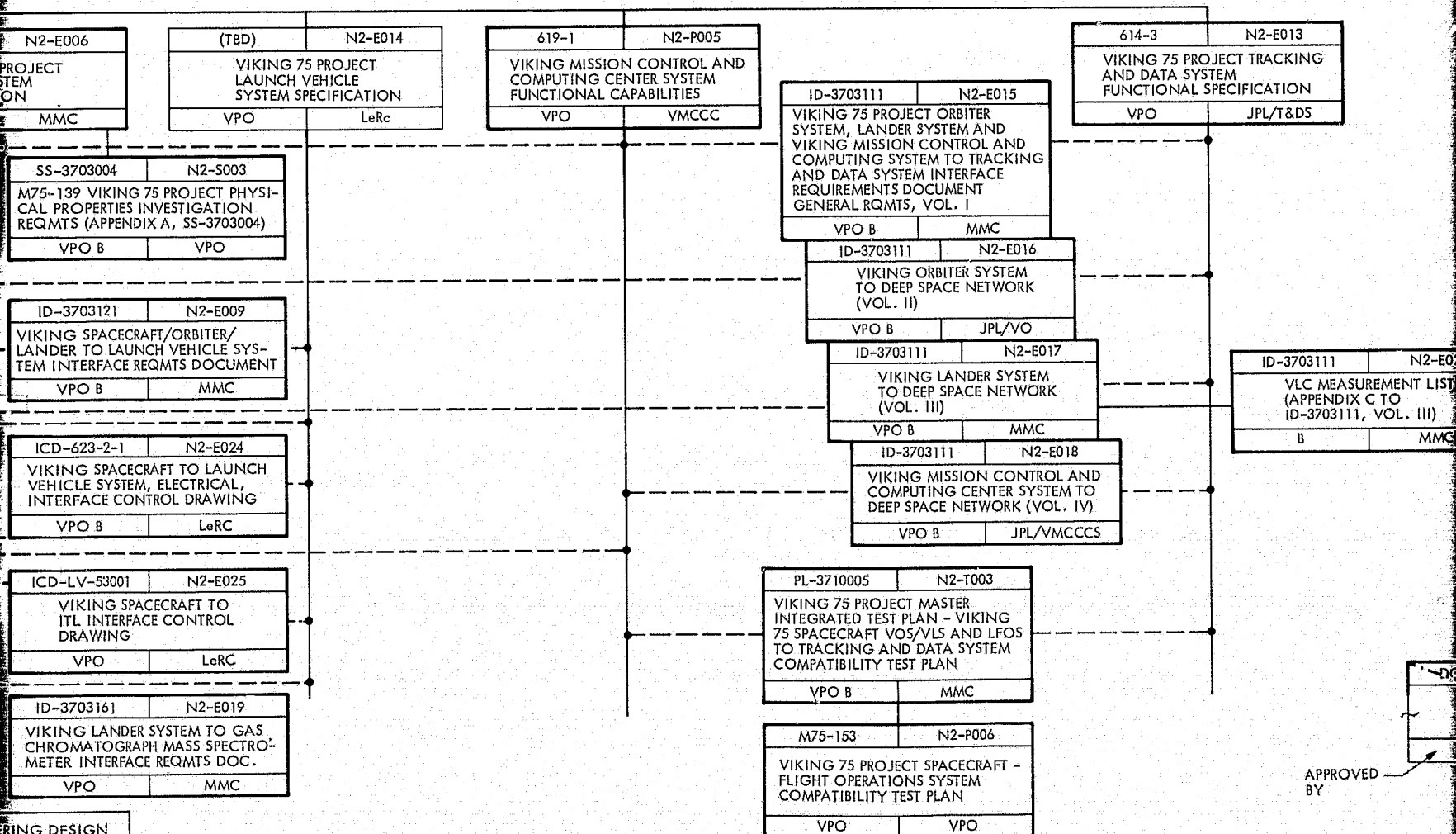

APPROVED BY

FOLDOUT FRAME 2

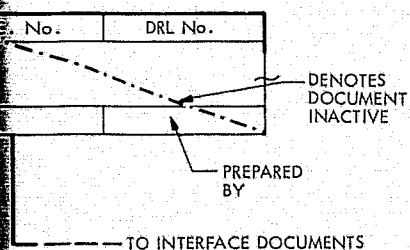
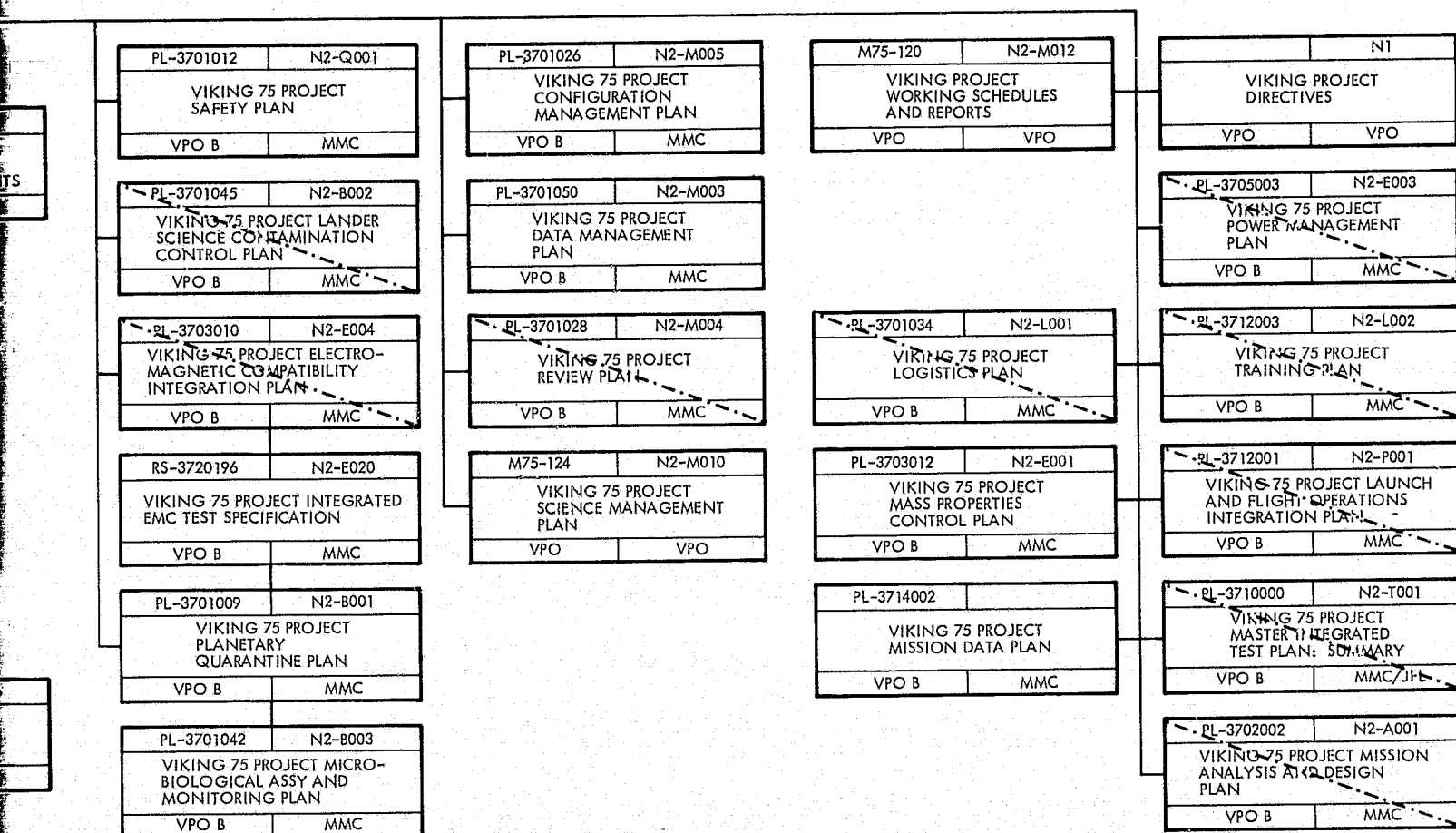

DRL DATA REQUIREMENTS LIST
 EMC ELECTROMAGNETIC COMPATIBILITY
 ITL INTEGRATE, TRANSFER, AND LAUNCH FACILITY
 JPL JET PROPULSION LABORATORY
 LeRC LEWIS RESEARCH CENTER
 L.FOS LAUNCH AND FLIGHT OPERATIONS SYSTEM
 MMC MARTIN MARIETTA CORPORATION
 NASA NATIONAL AERONAUTICS AND SPACE ADMINISTRATION
 T&DS TRACKING AND DATA SYSTEM
 VLC VIKING LANDER CONTROL
 VLS VIKING LANDER SYSTEM
 VMCCC VIKING MISSION CONTROL AND COMPUTING CENTER
 VO VIKING ORBITER
 VOS VIKING ORBITER SYSTEM
 VPO VIKING PROJECT OFFICE

Fig. 25. Viking 75 Project documentation tree as of January 1975

614-3 Viking 75 Project Tracking and Data System Functional Specification

ID3703111 Viking 75 Orbiter System, Lander System, and Viking Mission Control and Computing System to Tracking and Data System Interface Requirements Document - General Requirements, Volume I

ID3703111 Viking Orbiter System to Deep Space Network, Volume II

ID3703111 Viking Lander System to Deep Space Network, Volume III

ID3703111 Viking Mission Control and Computing Center System to Deep Space Network, Volume IV

The Network participated in the preparation of many other documents to which its concurrence was required as follows:

RS 3703001 Appendix A Viking 75 Mission Requirements of System Design

RS 370300 Appendix F Viking 75 Project Radio Science Investigation Requirements

PL3701036 Viking 75 Configuration Management Plan

M75-120 Viking 75 Working Schedules and Reports

IR 3720154 Viking 75 Science Objectives Requirements Document

RD 3713008 Support Instrumentations Requirements Document

RD 3701050 Viking Data Management Plan

RD 3701028 Project Review Plan

RD 3712003 Viking 75 Training Plan

RD 3712004 Viking Launch and Flight Operations System Functional Specifications

RD 3712001 Viking 75 Launch and Flight Operations Integration Plan

RD 3712001 Viking 75 Launch and Flight Operations Integration Plan

PL 3714002	Viking 75 Mission Data Plan
PL 3110000	Viking 75 Master Integration Test Plan Summary Viking 75 Project Integrated Test Plan -- Viking 75 Spacecraft VOS/LS & LFOS to Tracking and Data System Compatibility Test Plan
M75-153	Viking 75 Spacecraft to Flight Operations System Compatibility Test Plan

By the time of the Viking launches, many of the above documents had served their intended purpose and become inactive. Other, particularly the interface agreements, remained active as useful technical reference documents.

Finally, the Support Instrumentation Requirements Document remained throughout the Project as the formal vehicle for transfer of new and changed requirements for support from the Project to the Tracking and Data System, while the National Aeronautics and Space Administration Support Plan remained the formal document for the System response. During the course of the Project, the Requirements Document went through 11 revisions, while the Support Plan responded with three revisions.

The monthly editions of the "Working Schedules and Reports" continued throughout the project and became known as the "Granite Book." System contributions in both narrative and schedule form were made monthly for over seven years.

The development of so many documents, and in addition the review for concurrence of so many more, together with the concomitant load of approving so many changes to previously approved documents presented an overwhelming load on the Deep Space Network. This problem was never satisfactorily overcome.

It is a legitimate question as to whether so many documents were really necessary to the conduct of the Project. There were many instances where documents were offered up to the Network for concurrence that contained little and in some cases no involvement by the Network. At the other end of the scale, it is noteworthy that of all the interfaces between the Network, Orbiters, Landers, Mission Control Center, and Flight Operations System only one error was identified. Fortunately this error was compensated for by a change to the Mission Control Center software with no impact to ongoing flight operations.

4. Working Relationships

During the years preceding the 1975 launches, the planning, coordination, and scheduling activity of the entire project was carried out by means of an extensive array of working groups, design teams, and review panels. Because of the large number of these suborganizations, their geographical and institutional separations and interrelations between them, the creation and subsequent activity of all the groups was rigidly controlled and monitored by the Viking Project Office at Langley Research Center.

Both the Deep Space and near-Earth elements of the Tracking and Data System became heavily involved in supporting the various kinds of activity of these working groups.

a. Near-Earth Support. The near-Earth support accomplished most of the necessary coordination and interface work within three major working groups. One of these working groups was the Near-Earth Analysis Subgroup, which was chaired by the Lewis Research Center and was part of the Project Mission Analysis Design Group. All near-Earth inputs to the early Project Mission Design effort were submitted as recommendations via this group.

Another working group regularly supported by the near-Earth support system was the Performance Trajectory and Guidance Working Group for Viking chaired by the Lewis Research Center. All near-Earth system inputs to the launch vehicle trajectory design were submitted via these meetings. Also, the necessary trajectory information needed by the near-Earth support system was requested and coordinated at these meetings.

Chaired by Jet Propulsion Laboratory personnel at Cape Canaveral Air Force Station and Eastern Test Range, the near-Earth Working Group was supported by all elements of the near-Earth system, Lewis Research Center, and Langley Research Center. These meetings were primarily for interagency coordination between the elements of the Near-Earth Phase Network, to resolve near-Earth problems, and also to insure that preparations for testing and launch were accomplished in an adequate and timely manner.

b. Deep Space Support. The Deep Space Network became actively involved in the following organizations: Launch and Flight Operations, Telecommunications, and Compatibility Test Working Groups, the Mission Design Team, and the Project Management Review Panel.

The Launch and Flight Operations Working Group was formed at the beginning of the Project to integrate the long-range planning of the six Viking systems (Launch and Flight Operations, Launch Vehicle,

Orbiter, Lander, Viking Mission Control and Computing, and Tracking and Data), and to develop mutually compatible schedules leading to the completion of launch readiness preparations. Its initial findings were published in the Launch and Flight Operations Integration Plan. As the mission planning progressed, the launch operations function was separated from this working group, which then continued through the end of 1975 as the Flight Operations Working Group. Its work was heavily concerned with the integration of the mission operations system software programs with the Viking Mission Control and Computing Center, and to a lesser extent with Deep Space Network planetary implementation.

The Telecommunications Working Group was also formed at the outset of the Project, and its work was directed towards the development and specification of radio frequency telecommunications links between the ground stations in the Network and the Viking Orbiter and Lander. Its work was published in the series of volumes titled Orbiter System, Lander System, and Viking Mission Control and Computing System to Tracking and Data System Interface Requirements Document. As the spacecraft radio system matured, the Telecommunications Working Group was responsible for developing the radio frequency compatibility test plans and procedures and for final approval of the radio frequency compatibility test results.

The Compatibility Test Working Group was responsible for the development of all compatibility test planning throughout the Project and reflected its planning in the Master Integrated Test Plan from which the radio frequency compatibility tests were derived.

The Mission Design Team carried out most of the original development and tradeoffs for the design of the Viking Missions, and drew on the Network for support in areas related to navigational capabilities and accuracies.

The Project Management Review Panel was held under the chairmanship of the Viking Project Manager at the Viking Project Office and consisted of monthly progress reviews presented by each of the six system managers. It performed a valuable function in bringing together the otherwise widely separated elements of the Viking Project for regular reviews of progress and identification of intersystem problems.

In general, these groups met at monthly intervals at Cleveland, Ohio (Lewis Research Center), Denver, Colorado (Martin Marietta Corp.), Pasadena California (Jet Propulsion Laboratory), Hampton, Virginia (Langley Research Center), and Cape Canaveral (Air Force Kennedy Space Center). Visits were rotated where possible to share the very considerable travel load.

All meetings were formally structured and scheduled by the Viking Project Office, and formal minutes, containing all material presented and discussed, were written as approved by Viking Project Office and distributed throughout the project. Action items were assigned by the chairman with closeout dates, and their status also was checked out weekly by the project office until completed.

The burden posed by this method of working, which was increased to a large extent by the demands of long distance travel several times per month, seemed intolerable on many occasions, and often appeared to be less than an efficient way of achieving the necessary communications environment. However, a better alternative was not forthcoming and most of the work was accomplished by mid-1975.

With both spacecraft launched, the focus of activity moved to Jet Propulsion Laboratory where the working relationships necessary to conduct the cruise mission and plan the planetary mission were much easier to establish.

33-783, Vol. I

PART B

IMPLEMENTATION, TESTING, AND TRAINING

I. INTRODUCTION

Preparation for the complex Viking mission extended over a period of seven years before the successful launches of the two spacecraft in August and September 1975. During this period, elements of the Tracking and Data System met all planning, implementation, and test support requirements. These included complications that resulted from the rescheduling of the 1975 launch for both spacecraft. (Viking A launch was postponed from August 11 to August 15 and finally to August 20, and Viking B launch was postponed from September 1 to September 3 to launch on September 9.)

Details of the requirements levied by the Viking Project upon the Tracking and Data System for support in the Near-Earth and Deep Space Phases are given in Part A of this document.

The implementation, testing, and operational training required to provide the operational capabilities required by the Mission are described in this second part of the document.

MISSING PAGE BLANK NOT FILED

II. NEAR-EARTH PHASE SUPPORT

A. CONFIGURATIONS, IMPLEMENTATION, TRAJECTORIES, CONTROL

1. Station Configurations

The original planning for Viking support included the Ascension Island Station, two Advanced Range Instrumentation Aircraft, and the ship Vanguard. But a conflict developed between the Apollo-Soyuz Test Project and Viking for the use of the Vanguard during the Viking launch period. After negotiations between the Apollo-Soyuz and Viking Project offices, the ship was assigned to support Apollo-Soyuz with the understanding that, if the Tananarive sites were not available to support Viking, negotiations would be reopened.

The basic downrange station support for Viking then became Ascension Island, two aircraft, Johannesburg, and Tananarive. However, the U.S. contract for station support at Tananarive expired on December 31, 1973, and negotiations for a continuation of the Tananarive support were lengthy, leaving the availability of the Station in doubt. Renegotiations for the Vanguard did not prove very fruitful for the Viking A mission because of the strong need for the Vanguard by the Apollo-Soyuz Test Project. A parallel plan for supporting Viking using Ascension Island Station, two aircraft, and the Johannesburg Station only was worked in detail in the event it would be needed. The Vanguard sail plan for supporting the Apollo-Soyuz Test Project, then sailing to the Viking Test Support Position off the southeast coast of Africa was 33 days in duration. This allowed the Vanguard to make the nominal Viking B Test Support Position, but not the Viking A support position.

The first Titan Centaur Proof Flight TC-1 experienced a failure at the Second Main Engine Start and for this reason Lewis Research Center was much interested in the Second Main Engine Start interval for Viking. Lewis Research Center levied an additional requirement for dual aircraft coverage during this interval

This additional requirement increased the downrange aircraft support from two aircraft to three.

Stations at Ascension Island, Johannesburg, and Tananarive, together with the three aircraft continued to be the primary near-Earth support configuration until approximately four months before launch when the status of Tananarive again became uncertain. At this time a plan was devised to release the Vanguard from Apollo-Soyuz support as soon as possible to support the Viking B Mission, and to support Mission A mandatory requirements with Ascension Island, three aircraft, and Johannesburg Stations only.

The station at Carnarvon was one of the original stations planned for Viking support. A study was made, however, that showed that this station, while highly desirable, was not necessary to support the mandatory Viking near-Earth requirements. This station was deactivated and was not available to support the Viking missions.

Two other stations called up shortly before launch were Guam and Orroral Valley, Australia. The latter was called up to support the Centaur telemetry links during and after Centaur blowdown. Guam was called up because of a potential strike of all the Australian stations. In the event this occurred, a Deep Space Network Madrid station would become the initial Network acquisition station instead of an Australian station. Guam was configured to receive, record, and transmit spacecraft engineering data via Merritt Island Station 71 in real time to the Flight Operations Area at Jet Propulsion Laboratory continuously until Madrid acquisition some five hours after launch.

The schedule of the Air Force Eastern Test Range ship Redstone would not allow support by this resource for most of the Viking launch opportunity. The Air Force range was asked to investigate the possibility of support by a Pacific Missile Range ship, the Wheeling, which normally supports in the Kwajalein area. The Air Force range reported that a minimum of \$20,000 in equipment would be needed to augment the limited real-time retransmission capability. The ship could support only for a limited period of time. The approximate costs would be \$4,000 per day with 65 days port-to-port time for a 10-day Viking test position duration. The use of the Wheeling was not pursued further.

2. Station Implementation

a. Telemetry System. Near-Earth support for telemetry came from facilities of the Kennedy Space Center, Goddard's Space Flight Tracking and Data Network, Air Force Eastern Test Range, and the Deep Space Network. The near-Earth telemetry system consisted of the Launch Vehicle Telemetry System and the Spacecraft Telemetry System.

The Launch Vehicle telemetry system implementation consisted of receiving, processing, and displaying telemetry data from the Titan and Centaur. For the Launch Vehicle telemetry, there were three radio-frequency telemetry links: 2202.5-MHz pulse-code modulation/frequency modulation; 2208.5-MHz frequency modulation/frequency modulation; and 2287.5-MHz pulse-code modulation/frequency modulation. The near-Earth configuration for receiving, processing, and displaying the Launch Vehicle telemetry is shown in Fig. 26.

Spacecraft telemetry was received, processed, and retransmitted from the near-Earth stations from two radio frequency sources. While the spacecraft was attached to the Centaur, the spacecraft data (33-1/3 bps) were available within the Centaur 2202.5-MHz pulse-code modulation/frequency modulation 267-kbps data stream. In addition, the spacecraft radiated the 2295-MHz pulse-code modulation/phase-shift keying/phase modulation 33-1/3-bps data stream through its own low-gain antenna system. The near-Earth telemetry configuration for both radio frequency links is shown in Fig. 27. The retransmission of real-time spacecraft telemetry data was performed in the configuration shown in Fig. 28.

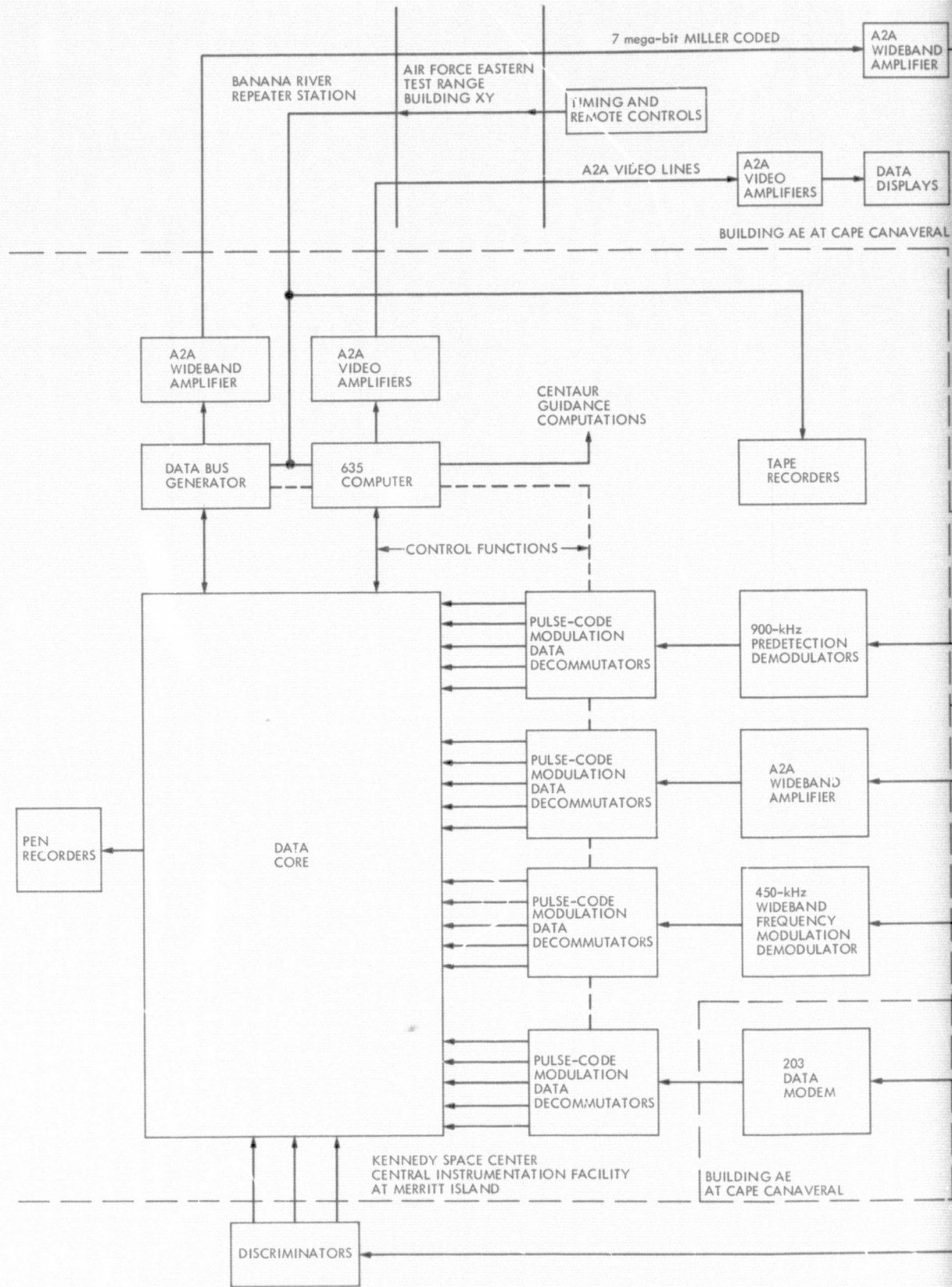

FOLDOUT FRAME

PRECEDING PAGE BLANK NOT FILMED

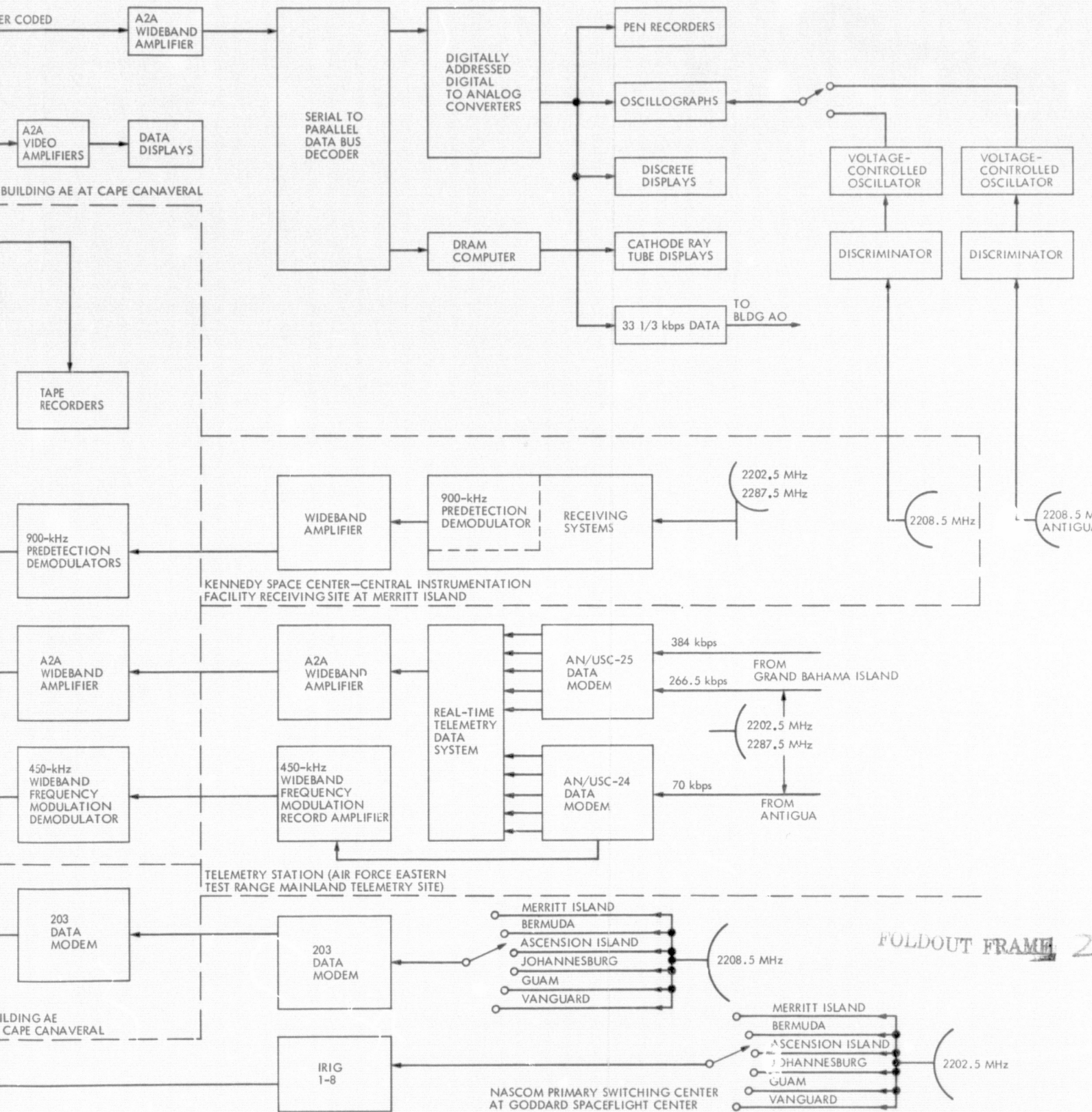

Fig. 26. Launch vehicle telemetry configuration for Viking

FOLDOUT FRAME 2

REPRODUCING PAGE BLANK NOT FILLED

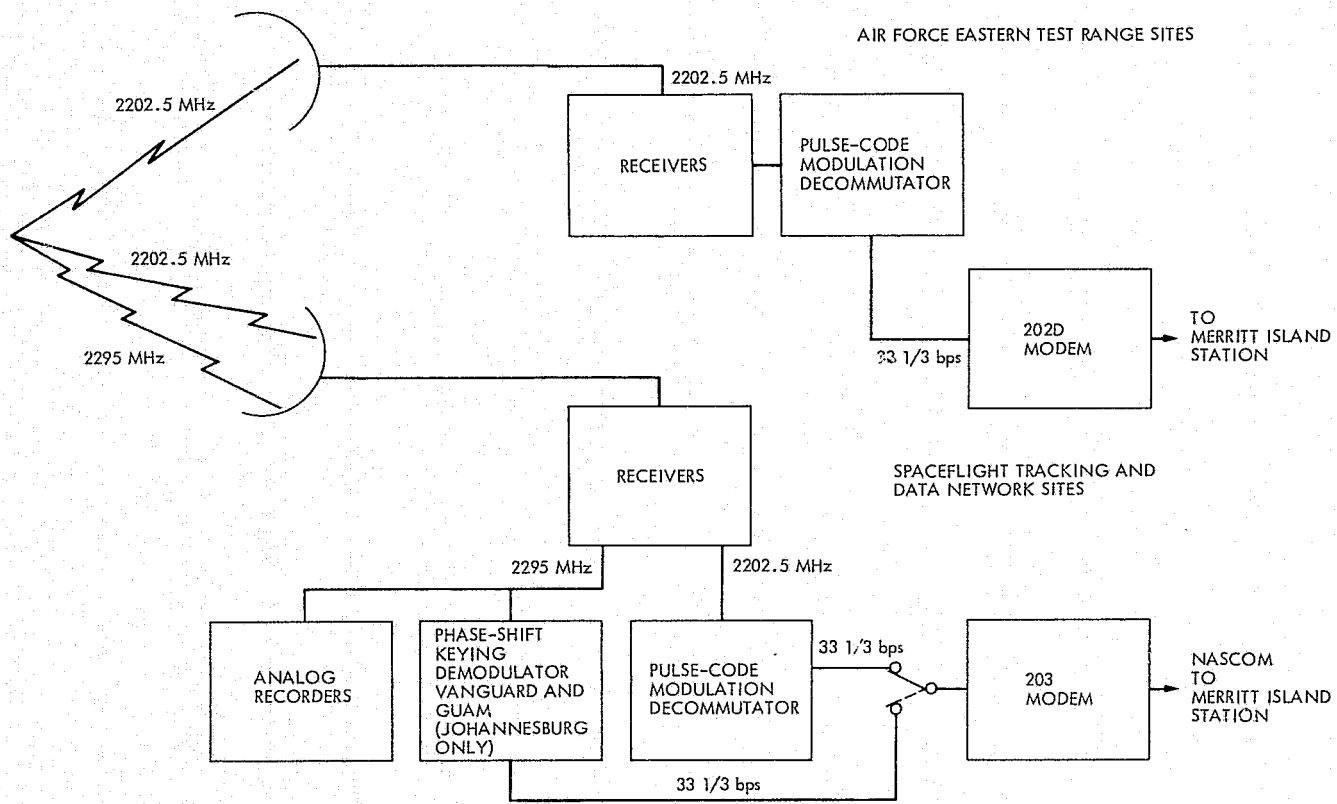

Fig. 27. Near-Earth telemetry configuration

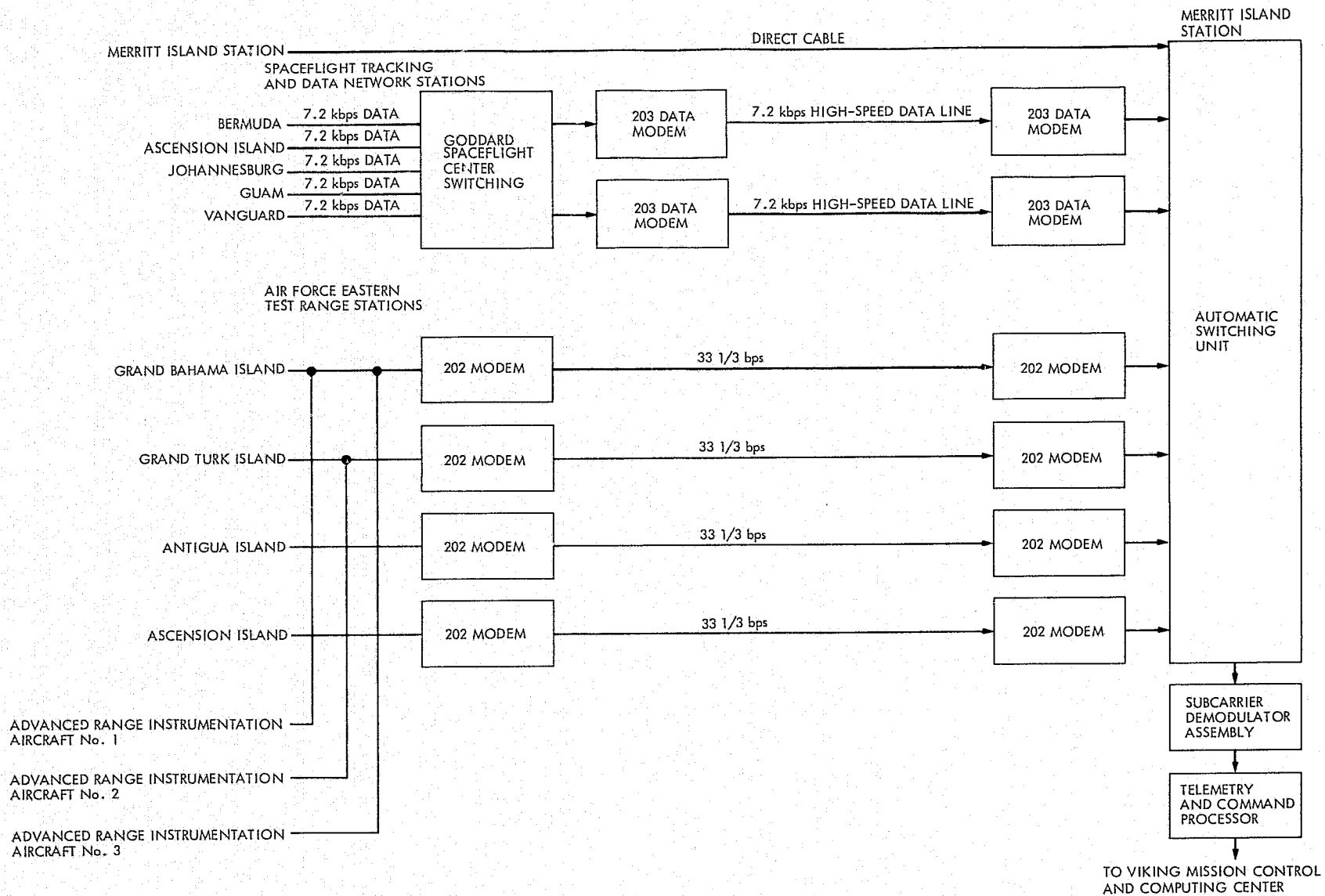

Fig. 28. Near-Earth station data transmission configuration

The 2202.5-MHz Centaur link was selected as the primary link for spacecraft telemetered engineering data from launch to Centaur/Spacecraft separation. This link was selected because the spacecraft 2295-MHz link was degraded because of a 40-db muffler of absorption material, which was located in front of the spacecraft low-gain antenna.

On some of the earlier near-Earth planetary missions, low bit rate spacecraft data were brought back to the Merritt Island Station by standard frequency subcarriers. This was done because of a shortage of data circuits to the Cape from the downrange stations and the desire to also bring back portions of both launch vehicle telemetry links. This was the original plan for the Viking missions.

When the retransmission of the spacecraft data became a mandatory requirement, the retransmission of these data by Type 203 Modems was recommended to improve the retransmission configuration. Past experience indicated that those units were easier to checkout and provided a high percentage of good data transferred to Merritt Island. So, the decision was to use this configuration for real-time transmission of the spacecraft data. To accomplish this, the transmission of selected parameters from the launch vehicle 2208.5-MHz link was sent back to the Cape shortly after the station pass instead of in near-real time.

An update of the mandatory launch vehicle telemetry requirements indicated that it would be acceptable for the interval Second Main Engine Start -60 seconds to Second Main Engine Start +130 seconds, to be supported by dual aircraft as well as by a ground-based station or by ship-based station. Three aircraft were to provide overlapping coverage between Ascension and Johannesburg. The third was optimized to provide coverage of the launch vehicle 2202.5-MHz link from Second Main Engine Start -60 seconds to Second Main Engine Start +130 seconds. Figure 29 depicts this typical coverage planned.

In February (1974), the Air Force Eastern Test Range advised that, because of the continuing energy crisis, Range policy on deployment of aircraft had been modified. The aircraft burns approximately 2,442 gallons of fuel per flying hour, and the deletion of aircraft support for all except truly mandatory requirements would result in a significant reduction in the aviation fuel consumed. A requirement for back-up support for reliability purposes was no longer considered (by the Air Force Range) a valid mandatory requirement. The Range would no longer provide aircraft support for other than mandatory data priority classification requirements.

In determining the configuration of the aircraft for the real-time telemetry retransmission, the Range conducted tests with the aircraft through the LES-6 satellite. It was determined that the entire Centaur 2202.5-MHz telemetry link could not be retransmitted in real time.

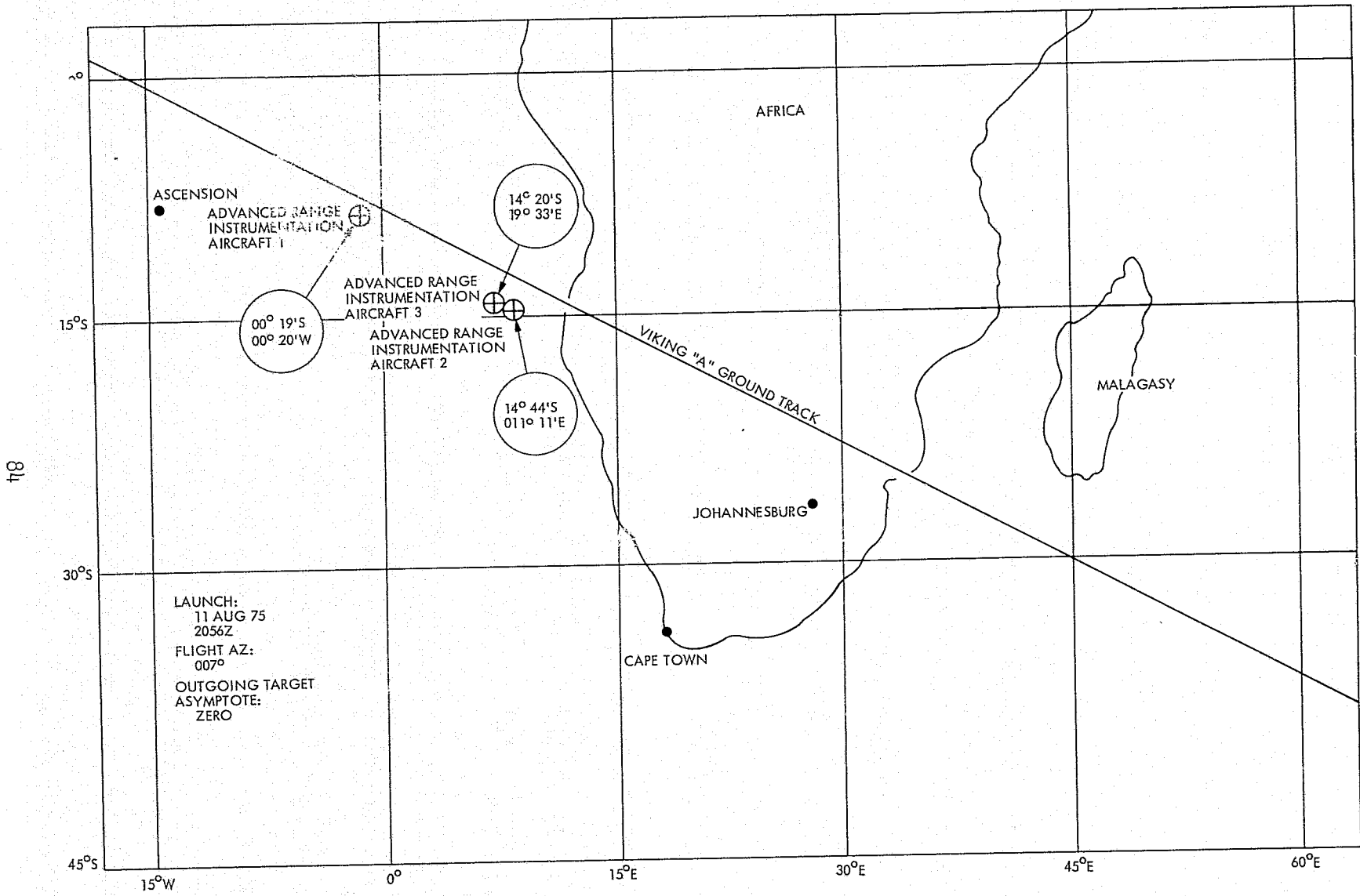

Fig. 29. Typical Advanced Range Instrumentation Aircraft coverage for Viking Mission A

Therefore, it was decided that the spacecraft's 33-1.3-bps data would be extracted from the Centaur link and retransmitted to Merritt Island. It was initially estimated that approximately \$21,300 would be required for equipment (demod synchronizers, digital-to-analog converter, filters, voltage controlled oscillator and associated hardware), and approximately \$30,400 for labor to provide this aircraft real time retransmission and mark event readout capability.

The final configuration of the aircraft was as shown in Fig. 30.

b. Metric Data System. The near-Earth metric system configuration was implemented as indicated in Fig. 31.

The Grand Turk radar did not support the Viking missions because it was down for Air Force range improvement modifications. This radar was not needed to support the metric data mandatory requirements.

As an aid to the Navigation Team at the Jet Propulsion Laboratory, a new near-real time procedure for passing Centaur guidance telemetry was developed. This procedure was implemented to expedite an early indication of abnormalcy of the Centaur second burn if it occurred. This was especially important to the Navigation Team plan for an emergency midcourse maneuver if it were needed.

A Jet Propulsion Laboratory Centaur Guidance telemetry coordinator provided orbital element information in near-real time as indicated in Fig. 32.

c. Station Mask Configurations. In the planning for the down-range support for Viking, it became apparent that the Johannesburg and Tananarive standard mask (4 to 4.5 degrees above the horizon) was limiting the usefulness of these stations in supporting Viking. Therefore, Goddard Space Flight Center was requested to lower these station masks.

Goddard responded by having Johannesburg support Viking with its "launch support" mask, which is mostly 1.9 to 1.5 degrees above horizon and closer key hole limits. The mask for the Tananarive station was not lowered, and reflected some loss of near-Earth support capability on certain launch days.

For planning purposes, a composite of the Ascension Spaceflight Tracking Data Network station and Ascension Air Force telemetry station was used for overall coverage by Ascension Island because of considerable differences in station masks.

d. Communications Systems. Project communications requirements in the near-Earth phase were for data and voice channels adequate to conduct test and launch operations.

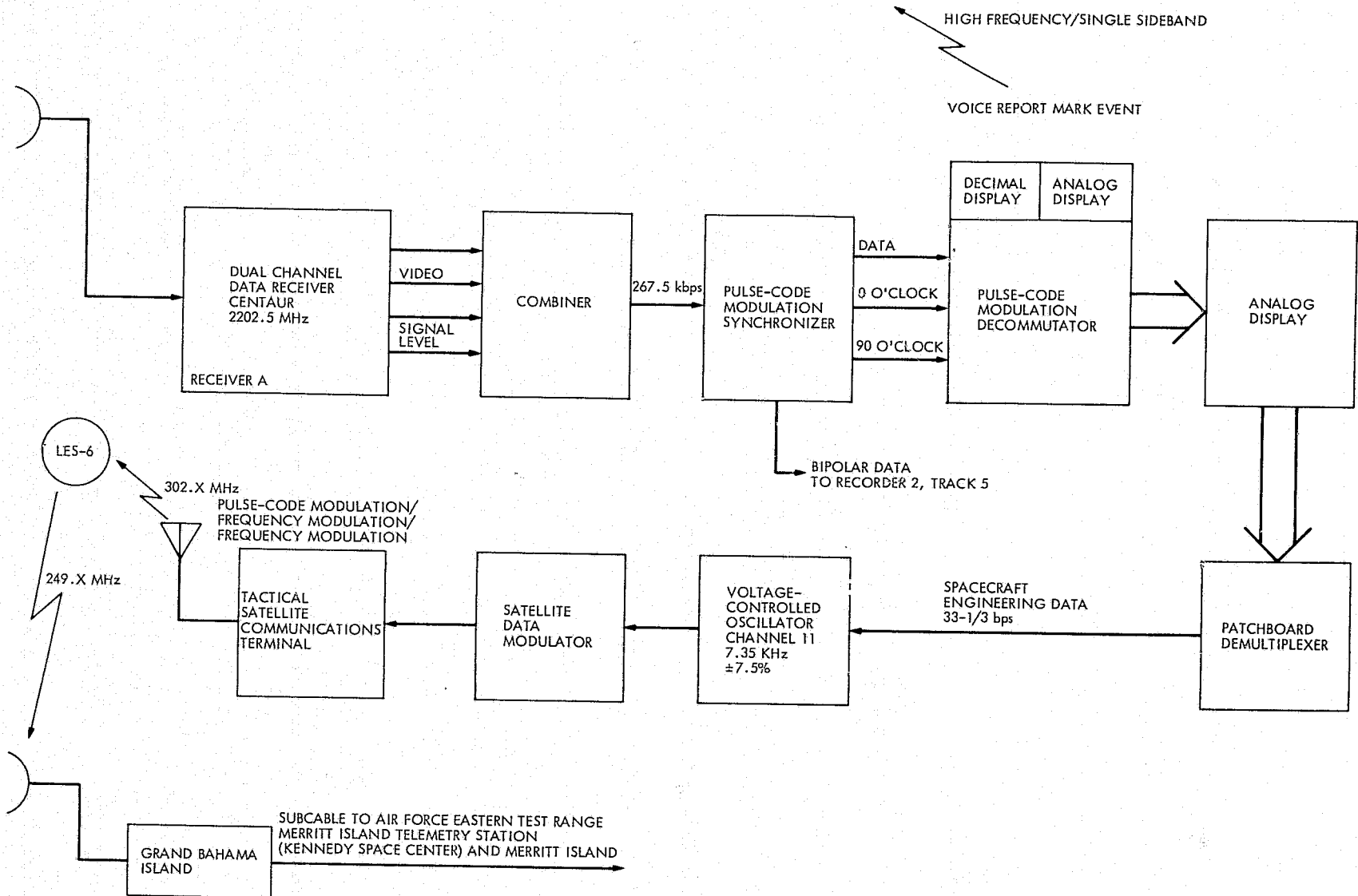

Fig. 30. Aircraft support for Project Viking; Centaur mark events main engine start No. 2 and main engine cutoff No. 2 engineering data from Centaur link

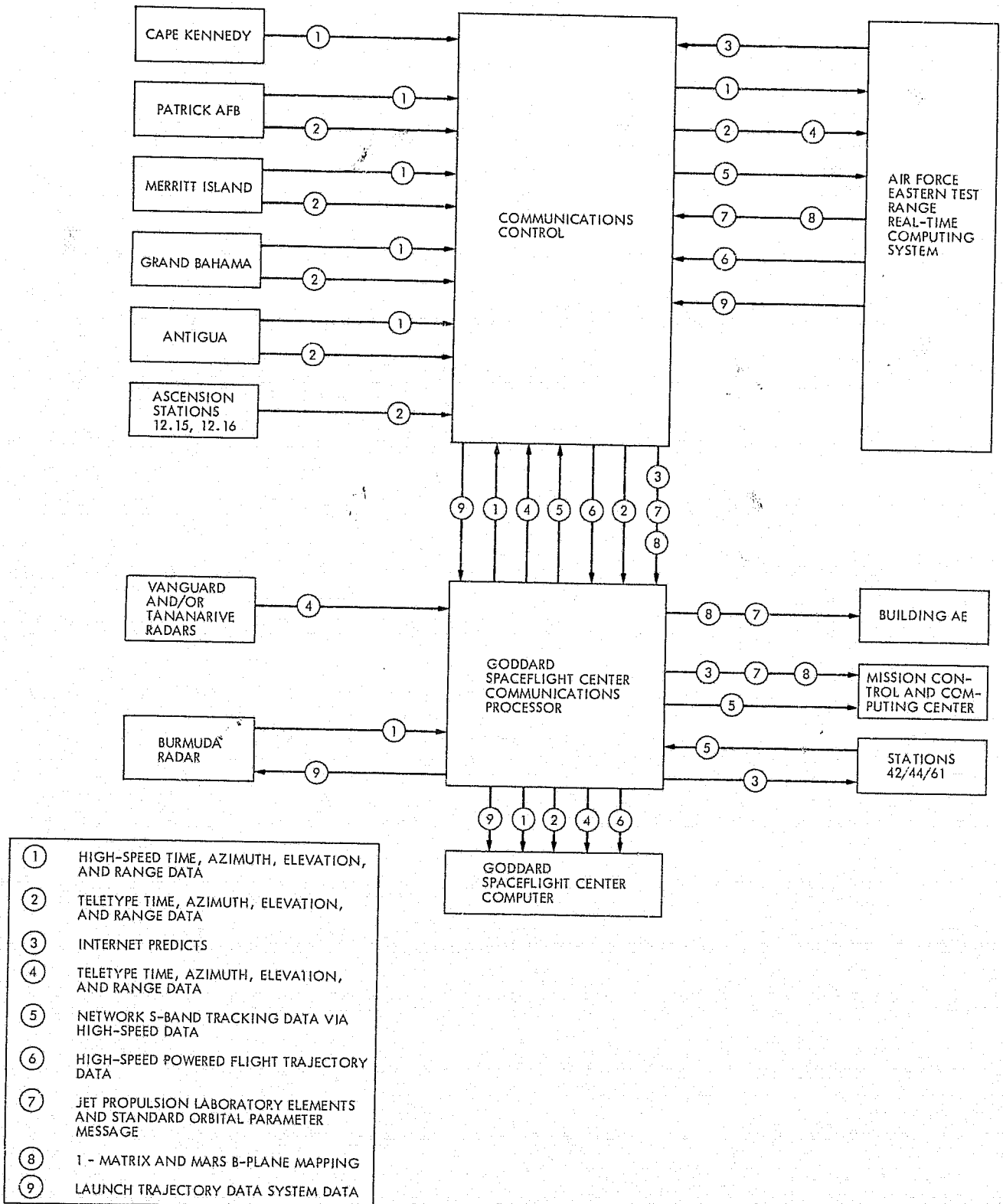

Fig. 31. Viking near-Earth metric data flow

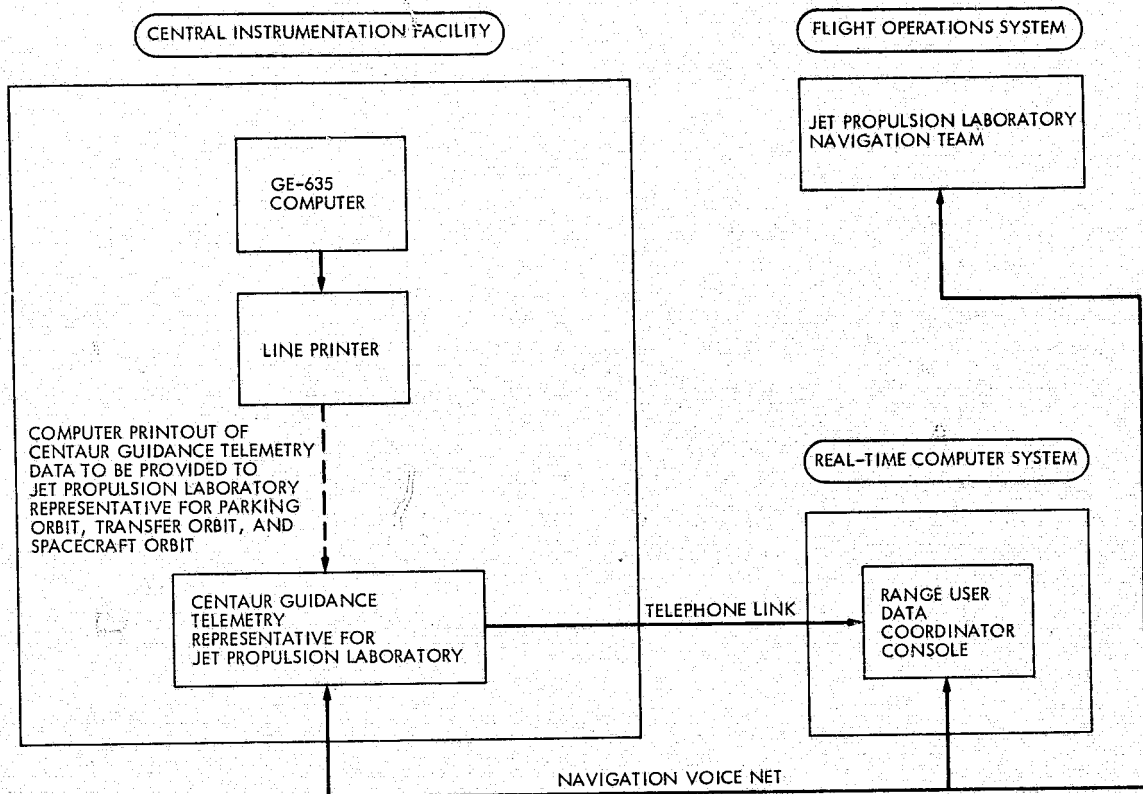

Fig. 32. Plan for providing Centaur guidance telemetry data to the Navigation Team

Ground Communications Facilities, which are presented in the Support Instrumentation Requirements Document for Viking 75, included voice nets, high-speed data, wideband data, and teletype. Location of terminals for the near-Earth phase was required at the Simulation Center and the Control Center in the Space Flight Operations Facility building at the Jet Propulsion Laboratory, and at Building AO, Building AE, the Real Time Computer Facilities, and Complex 41 at Cape Canaveral at the Merritt Island Station, Spacecraft Assembly and Encapsulation Facilities 1 and 2, and the Operations and Control Building at Kennedy Space Center. Supporting sites included elements of the Spacecraft Tracking and Data Network, Air Force Eastern Test Range, and Deep Space Network.

To carry out the assigned responsibilities, a Viking Communications Chief and a Viking Communications Scheduler were established within the Near-Earth System Group. The Viking Communications Chief worked with Communication personnel at Kennedy Space Center, Air Force Eastern Test Range, Goddard Space Flight Center, and Jet Propulsion Laboratory, and was the single point of contact to the National Aeronautics and Space Administration Communications for all real-time operations.

A Communication Plan was published by the Near-Earth System Group describing the Voice and Data Communications Systems required to support all functions and operations during Testing Checkout of the spacecraft at Kennedy Space Center/Cape Canaveral Air Force Station and Launch. Communications required for Compatibility Testing with the Deep Space Network and the Flight Operations System and Near-Earth Phase Network were also included in this document. Figures 33, 34, and 35 show the Viking Project Voice, Data, and Teletype circuits.

3. Prelaunch Configurations of Near-Earth Stations

Three basic downrange station combinations were recommended for use in the event of an untimely loss of one or more of the near-Earth stations. These combinations of stations preferred in order as approved by the Project Manager were: (1) Ascension, two aircraft, and Tananarive; (2) Ascension, two aircraft, and Vanguard; and (3) Ascension, two aircraft, and Johannesburg. The Manager also approved a plan calling for approximately a one-hour launch window per day beginning at a launch azimuth no more northerly than 93 degrees.

4. Prelaunch Trajectory Selection

The trajectories for Viking were provided for launch days August 11, 1975, through October 13, 1975, and were broken into six different groupings. The first group was "Nominal Mission A" and consisted of launch days August 11, 1975, through August 22, 1975, with many of these launch days having more than one arrival date. The second group was "Extended Mission A" from August 23 to September 9, 1975. The third group was for a heavier mission, being called "Heavy Mission A," and ran from August 12, 1975 through August 22, 1975. The fourth and fifth groups were the "Nominal Mission B" period from August 21 through September 9, 1975, and the "Extended Mission B" period from September 10 through September 20, 1975. The last group of trajectories was for the "Contingency Mission B" period, which started with launch day September 21 and continued through October 13, 1975.

Provision of powered flight trajectory tapes for all the near-Earth trajectories proved to be formidable. So, Lewis Research Center, General Dynamics Convair, and the near-Earth representatives decided that a grid space of every 1 degree in launch azimuth and every 1 degree in outgoing target declination would be provided for the Viking missions. This called for approximately 300 powered flight trajectories that resulted in additional problems. The first problem was that the Viking grid space for the second burn was not adequate to provide accurate acquisition and expected coverage estimates without interpolating between trajectories for certain near-Earth stations such as Johannesburg and Tananarive. The second problem was concerned with Viking A and B trajectories having different C_3 energies than provided on magnetic tape.

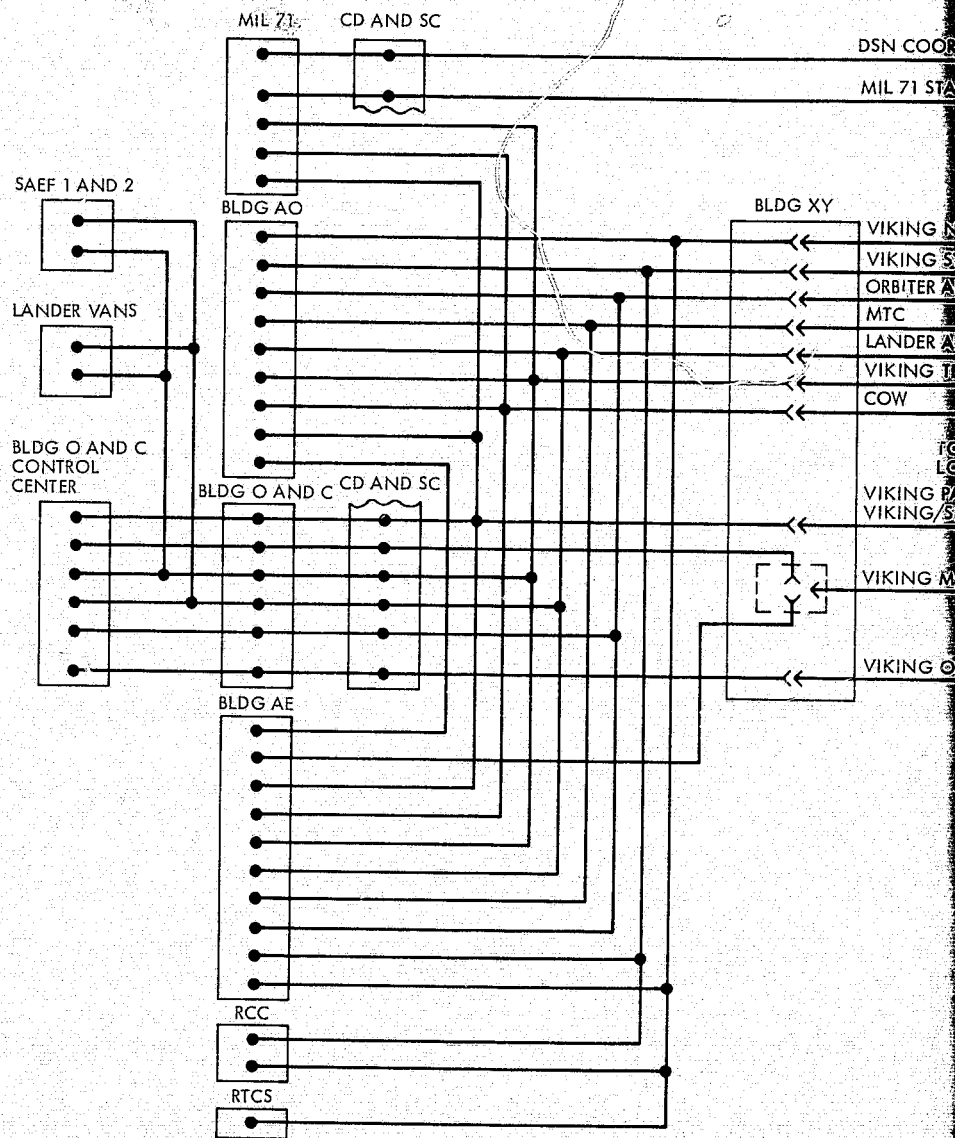

FOLDOUT FRAME 1

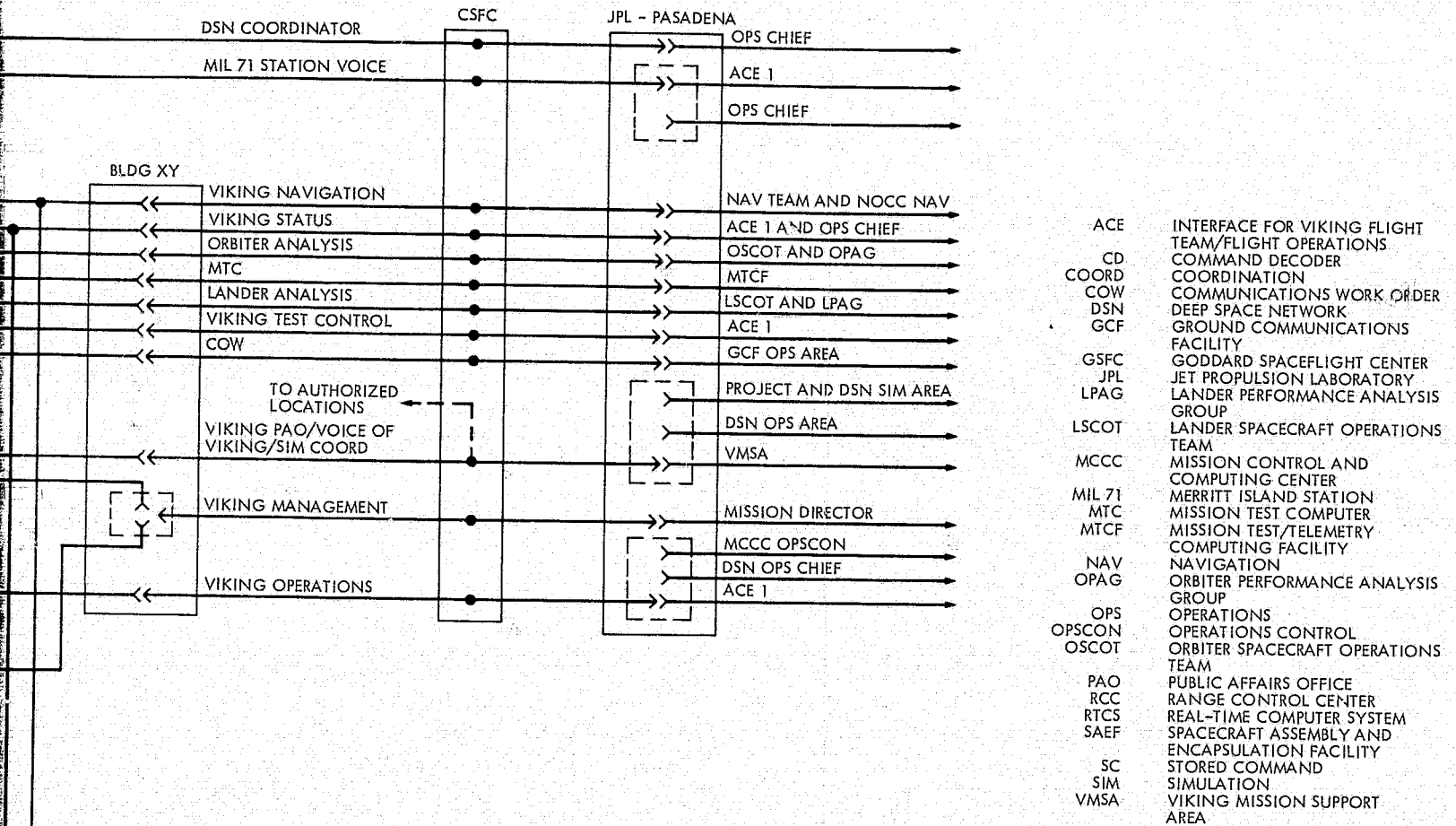
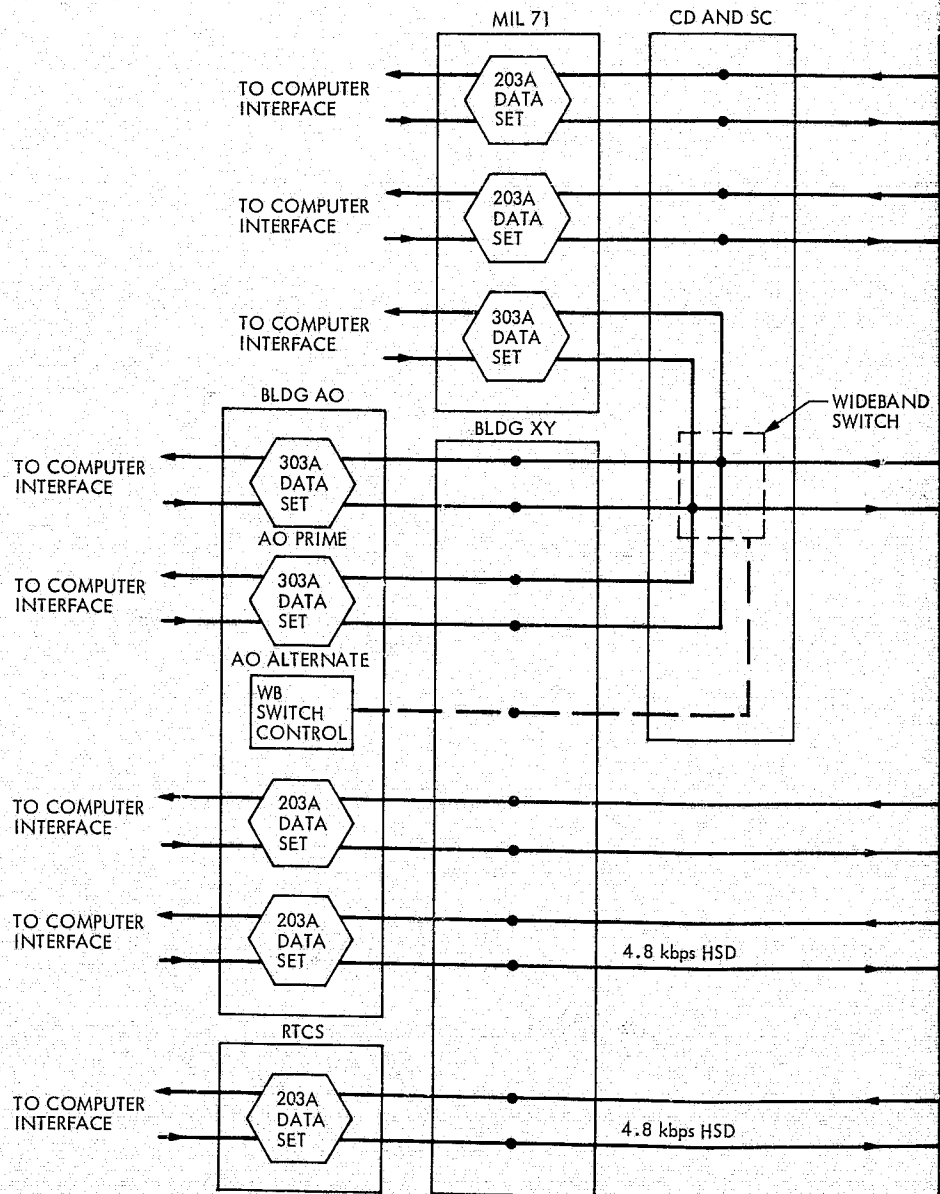

Fig. 33. Viking Project voice circuits

PREVIOUS PAGE BLANK NOT TO BE REPRODUCED

HOLDOUT FRAME 2



FOLDOUT FRAME

PREVIOUS PAGE BLANK NOT FILLED

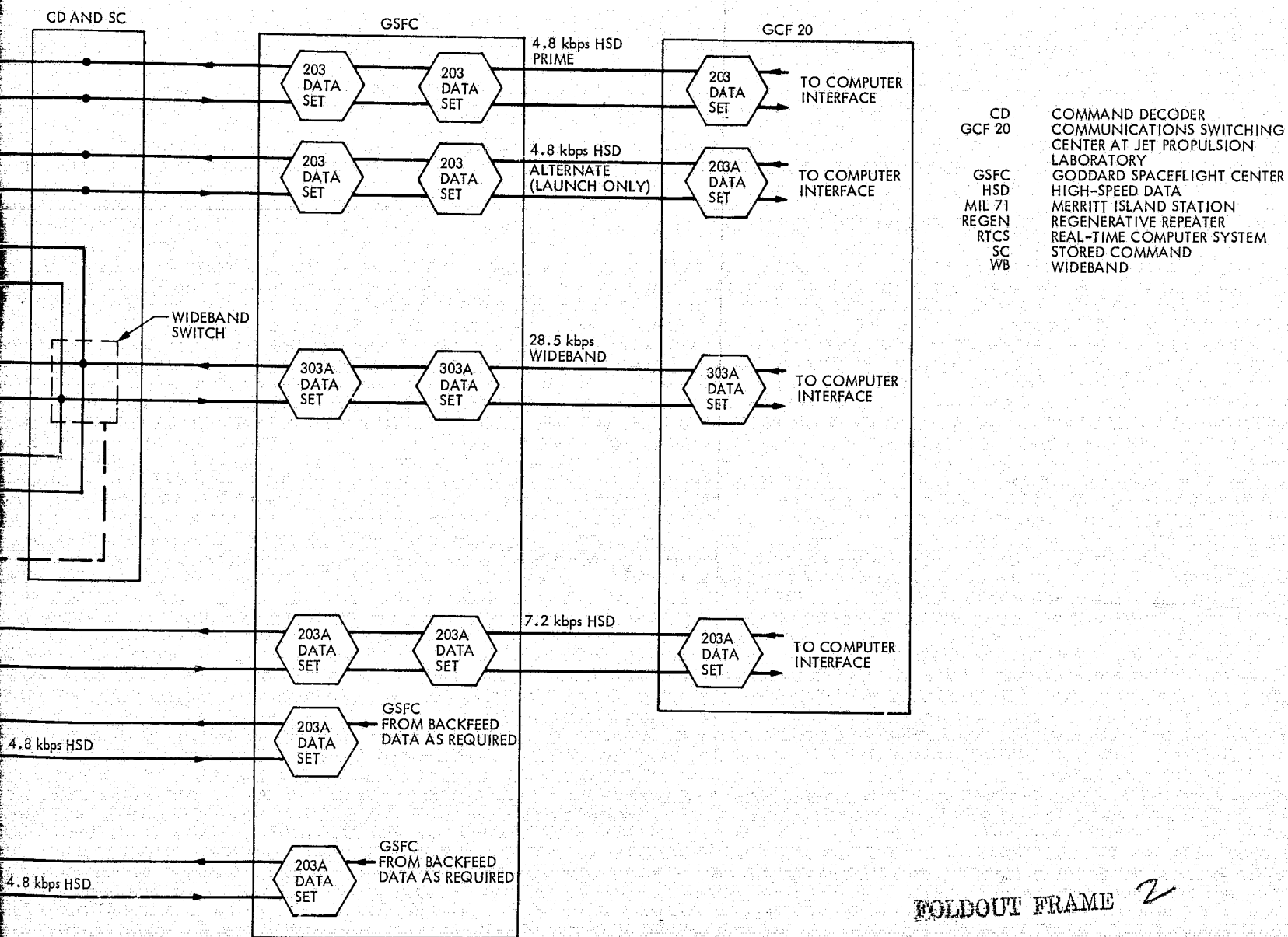

FOLDOUT FRAME 2

Fig. 34. Viking Project data circuits for near-Earth support

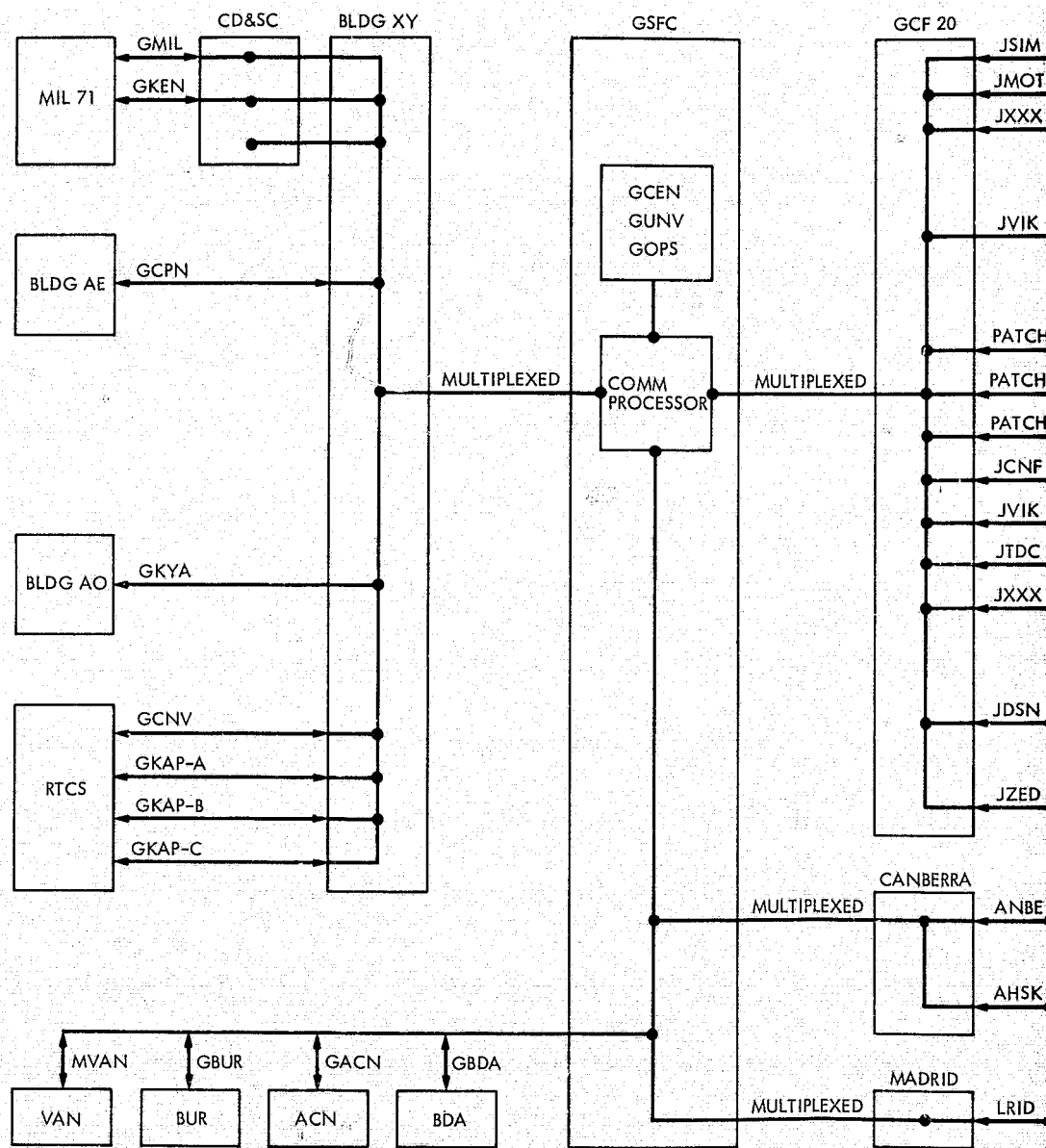

FOLDOUT FRAME /

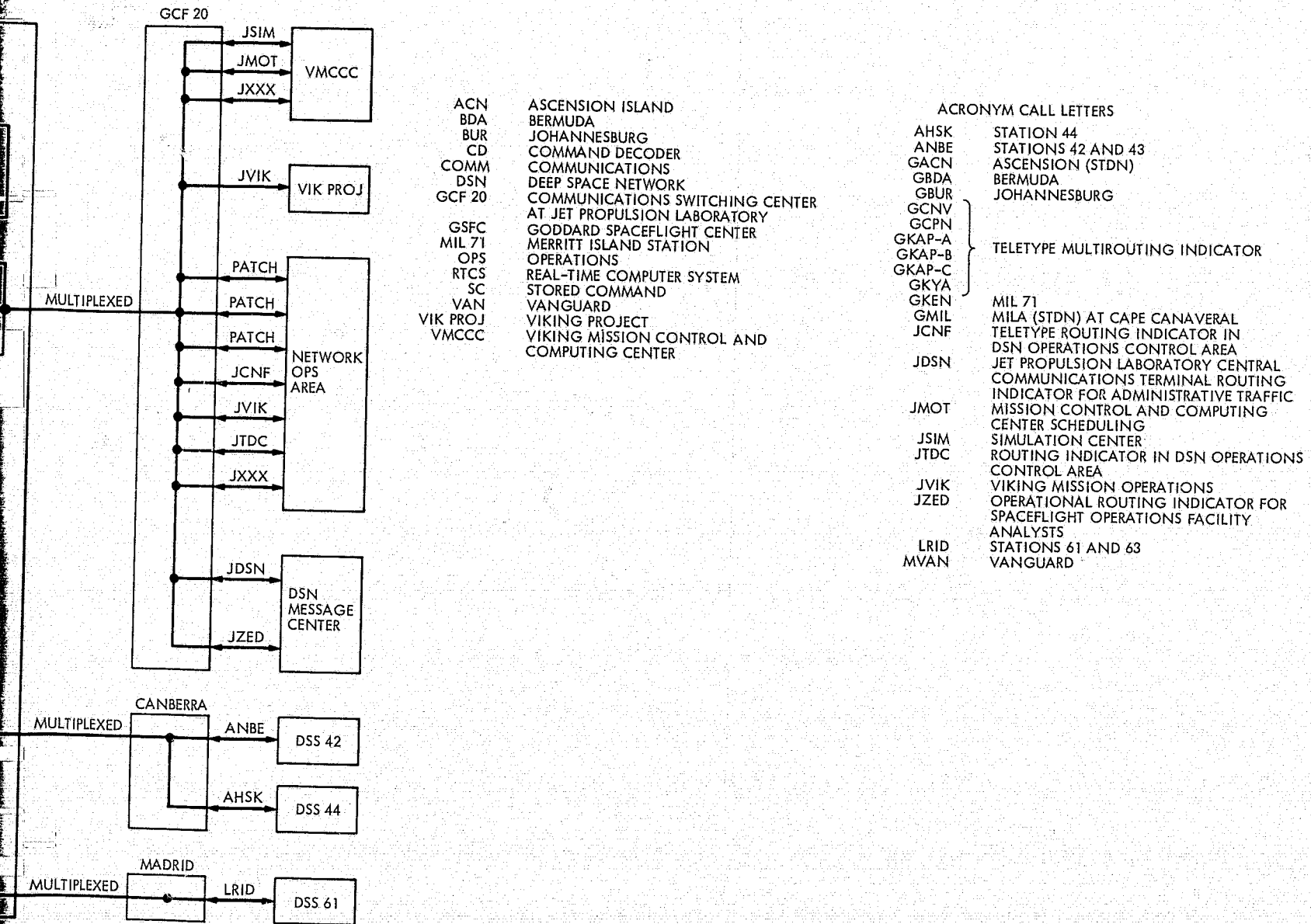

Fig. 35. Viking Project teletype circuits for near-Earth support

FOLDOUT FRAME 2

REPRODUCING PAGE BLANK NOT FILLED

However, these problems were solved by Goddard interpolating the necessary powered flight tapes and detailed correlation being devised to indicate which powered flight tapes to use for a given launch day/arrival date. This correlation was based on launch azimuth and time of Second Main Engine Start. Final trajectory selection was generally for a 60- to 75-minute launch window per day starting at a launch azimuth of 96 of 97 degrees.

5. Operational Control

The near-Earth control provided interfaces and communications to maintain updated awareness of the operational status of participating elements. It also provided operational coordination and control between near-Earth elements of the Tracking and Data System and Viking Project Management during this phase of the operations.

Figure 36 illustrates the near-Earth operational positions, locations, interfaces, and voice communications links. The roles of the Coordinator, Range User Data Coordinator, Associate Test Controller and Telemetry Engineer during major testing and launch are described here.

The near-Earth Coordinator represented the Tracking and Data System Manager for operational cognizance of the near-Earth phase of the mission. To execute the basic responsibility of this position, the Coordinator relied heavily upon coordination with three other operational positions located at the Real-Time Computing System, Range Control Center, Spaceflight Tracking and Data Network/Merritt Island. Activities of the near-Earth elements were separated for monitoring status and for coordination among these positions. The Coordinator monitored overall systems countdown to ensure that near-Earth operations were compatible, and properly interrelated with, the Project's Master Countdown. The Coordinator's position provided the Viking Flight Team and the Jet Propulsion Laboratory with status information of general countdown activities, and coordinated integrated operations and activities. He also counseled the Tracking and Data System Manager on all matters relating to near-Earth operations.

The Range User Data Coordinator was the Viking Project Jet Propulsion Laboratory representative located at the Air Force Eastern Test Range Real-Time Computing System. His major function was to coordinate the flow of computed data from the computing system to the Viking Flight Team Flight Path Analysis Group at Pasadena. He was the Flight Team focal point for determining the need for computing system configuration changes, reruns of data processing, program troubleshooting, or other coordination or counseling for anomalous situations. At the Real-Time Computing System, the Range User, Data Coordinator coordinated the updating of the acquisition predict constant parameters used in the computing system Inter-Net Predict Program and the subsequent transmission of predicts to Deep Space Network stations. He provided

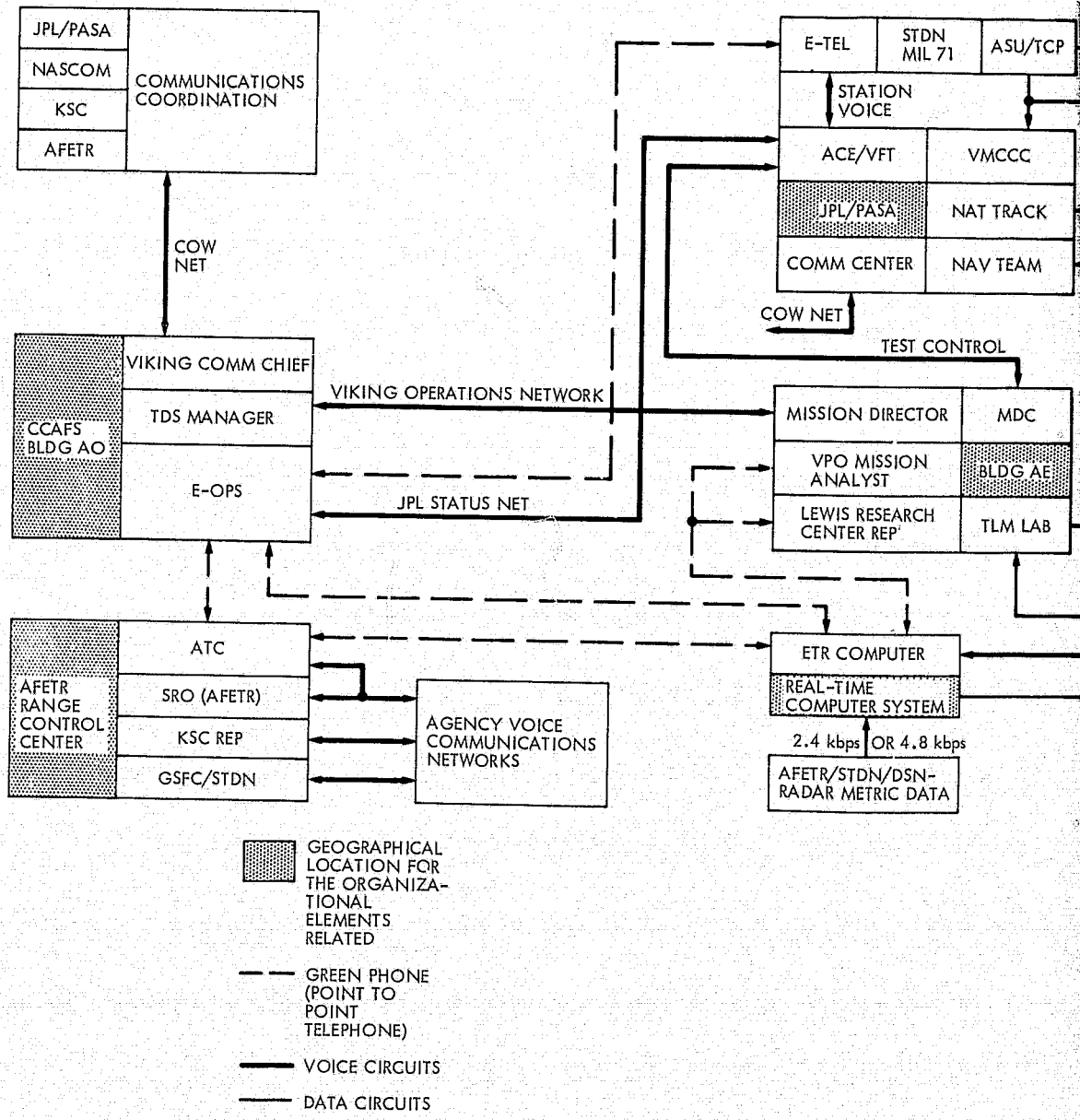
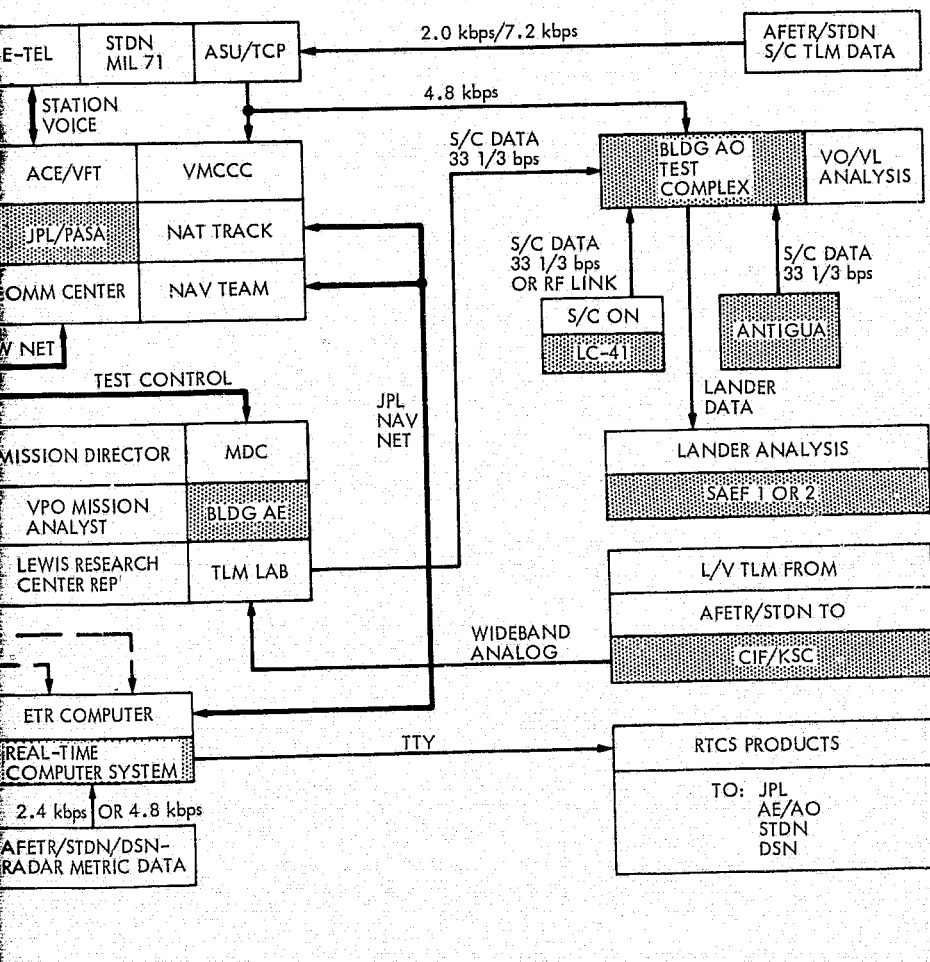

Fig. 36. Basic

FOLDOUT FRAME



ACE	INTERFACE FOR VIKING FLIGHT TEAM/FLIGHT OPERATIONS
AFETR	AIR FORCE EASTERN TEST RANGE
ASU	AUTOMATIC SWITCHING CENTER
ATC	ASSOCIATE TEST CONTROLLER
CCAFS	CAPE CANAVERAL AIR FORCE STATION
CIF	CENTRAL INSTRUMENTATION FACILITY
COMM	COMMUNICATIONS ORDER WIRE
COW	COMMUNICATIONS ORDER WIRE
DSN	DEEP SPACE NETWORK
E-OPS	NEAR-EARTH TRACKING AND DATA SYSTEM COORDINATES
E-TEL	NEAR-EARTH TRACKING AND DATA SYSTEM TELEMETRY ENGINEER
ETR	EASTERN TEST RANGE
GSFC	GODDARD SPACEFLIGHT CENTER
JPL	JET PROPULSION LABORATORY, PASADENA, CALIF.
KSC	KENNEDY SPACE CENTER
LAB	LABORATORY
LC	LAUNCH COMPLEX
L/V	LAUNCH VEHICLE
MDC	MISSION DIRECTOR'S CENTER
MIL 71	MERRITT ISLAND STATION
NASCOM	NATIONAL AERONAUTICS AND SPACE ADMINISTRATION COMMUNICATIONS NETWORK
NAT	NETWORK ANALYSIS TEAM
NAV	NAVIGATION
NET	NETWORK
REP	REPRESENTATIVE
RF	RADIO FREQUENCY
RTCS	REAL-TIME COMPUTER SYSTEM
SAEF	SPACECRAFT ASSEMBLY ENCAPSULATION FACILITY
S/C	SPACECRAFT
SRO	SUPERINTENDANT OF RANGE OPERATIONS
STDN	SPACEFLIGHT TRACKING AND DATA NETWORK
TCP	TELEMETRY AND COMMAND PROCESSOR
TDS	TRACKING AND DATA SYSTEM
TLM	TELEMETRY
TTY	TELETYPE
VFT	VIKING FLIGHT TEAM
VL	VIKING LANDER
VMCCC	VIKING MISSION CONTROL AND COMPUTING CENTER
VO	VIKING ORBITER
VPO	VIKING PROJECT OFFICE

Fig. 36. Basic near-Earth operational control communications interfaces and simplified data flow

FOLDOUT FRAME 2

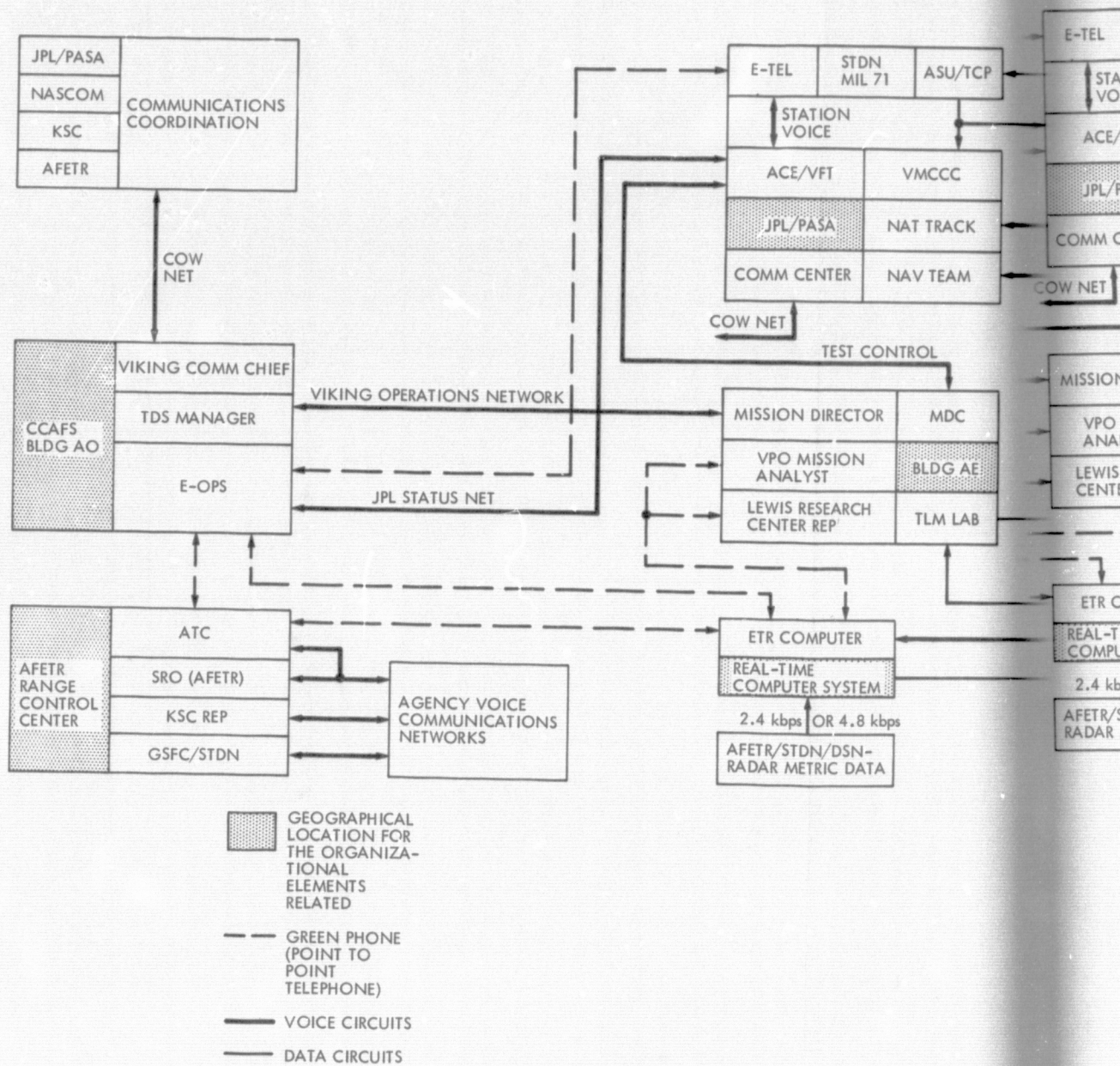
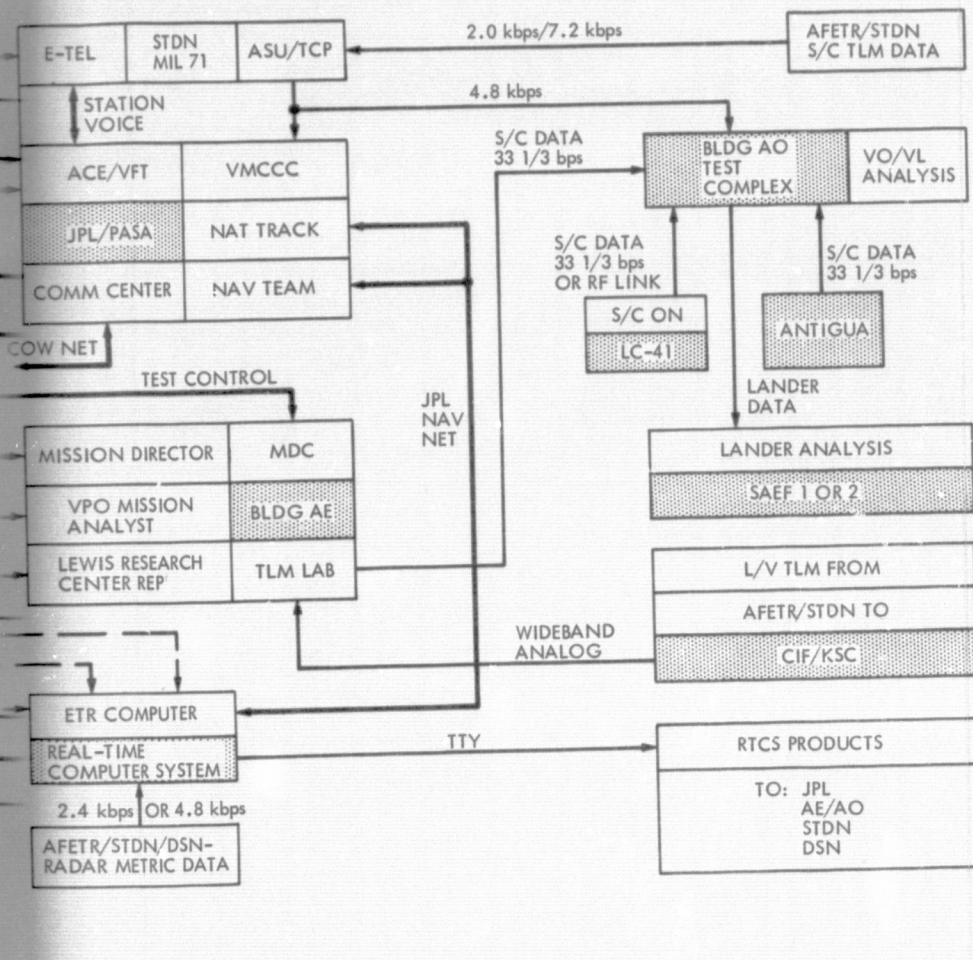

Fig. 36. Basic nee



ACE	INTERFACE FOR VIKING FLIGHT TEAM/FLIGHT OPERATIONS
AFETR	AIR FORCE EASTERN TEST RANGE
ASU	AUTOMATIC SWITCHING CENTER
ATC	ASSOCIATE TEST CONTROLLER
CCAFS	CAPE CANAVERAL AIR FORCE STATION
CIF	CENTRAL INSTRUMENTATION FACILITY
COMM	COMMUNICATIONS
COW	COMMUNICATIONS ORDER WIRE
DSN	DEEP SPACE NETWORK
E-OPS	NEAR-EARTH TRACKING AND DATA SYSTEM COORDINATES
E-TEL	NEAR-EARTH TRACKING AND DATA SYSTEM TELEMETRY ENGINEER
ETR	EASTERN TEST RANGE
GSFC	GODDARD SPACEFLIGHT CENTER
JPL	JET PROPULSION LABORATORY, PASADENA, CALIF.
KSC	KENNEDY SPACE CENTER
LAB	LABORATORY
LC	LAUNCH COMPLEX
L/V	LAUNCH VEHICLE
MDC	MISSION DIRECTOR'S CENTER
MIL 71	MERRITT ISLAND STATION
NASCOM	NATIONAL AERONAUTICS AND SPACE ADMINISTRATION COMMUNICATIONS NETWORK
NAT	NETWORK ANALYSIS TEAM
NAV	NAVIGATION
NET	NETWORK
REP	REPRESENTATIVE
RF	RADIO FREQUENCY
RTCS	REAL-TIME COMPUTER SYSTEM
SAEF	SPACECRAFT ASSEMBLY ENCAPSULATION FACILITY
S/C	SPACECRAFT
SRO	SUPERINTENDANT OF RANGE OPERATIONS
STDN	SPACEFLIGHT TRACKING AND DATA NETWORK
TCP	TELEMETRY AND COMMAND PROCESSOR
TDS	TRACKING AND DATA SYSTEM
TLM	TELEMETRY
TTY	TELETYPE
VFT	VIKING FLIGHT TEAM
VL	VIKING LANDER
VMCCC	VIKING MISSION CONTROL AND COMPUTING CENTER
VO	VIKING ORBITER
VPO	VIKING PROJECT OFFICE

Fig. 36. Basic near-Earth operational control communications interfaces and simplified data flow

FOLDOUT FRAME 2

estimates of the actual trajectory conformance with the nominal design, monitored the timeliness and the quality of the transmissions of orbital elements, predicts, and associated data to the Viking Mission Control and Computing Center.

The Associate Test Controller was located in the Air Force Eastern Test Range's Control Center where he interfaced directly with the Kennedy Space Center Representative (Test Controller), the Goddard Space Flight Center/Spaceflight Tracking and Data Network Representative, and, as appropriate, with the Air Force range Superintendent of Range Operations. The Goddard Center/Spaceflight Network Representative was in direct communication with the Spaceflight Network's Operations Manager who exercised operational control of the Spaceflight Network resources. Similarly, the Range Operations Superintendent exercised operational control of the Air Force Range resources, including the range aircraft. The Associate Test Controller worked closely with the near-Earth support Coordinator in reporting status information and acted as the agent for the Coordinator in all situations requiring operational control, particularly in changing, adding or deleting support requirements relating to the utilization of Kennedy Space Center, Spaceflight Tracking and Data Network, and the Air Force Eastern Test Range near-Earth resources.

The near-Earth Telemetry Engineer was located at the Spaceflight Tracking Data Network Merritt Island site. He coordinated all near-Earth support spacecraft telemetry data flow for all tests and operations that required spacecraft telemetry data to be transmitted to Jet Propulsion Laboratory. The flow of data to be coordinated originated from the Air Force Range and Spaceflight Network receiving sites and passed through the Merritt Island Station to the Viking Mission Support Area at the Jet Propulsion Laboratory. He counseled the near-Earth support Coordinator, as required, concerning the processing and transmission of the spacecraft telemetry data stream.

B. TESTING

1. General

The plan for prelaunch testing to be performed by the near-Earth support was published in March 1975. This plan defined all prelaunch testing required to verify the readiness of the near-Earth support system to participate in and to support the Viking 75 Flight Project test, training, and readiness program. Internal testing was a prerequisite and the responsibility of each individual agency supporting the near-Earth effort.

The Test Plan outlined launch support configuration and developed criteria and schedules for those detailed tests. These tests preceded participation in the overall mission operations and Ground Data System

tests. The major tests, which led to the ultimate performance readiness demonstration for Viking Project management, were the Operational Demonstration and Operations Readiness Tests.

The Near-Earth Test Plan was reviewed by project representatives on March 4, 1975. The objectives of the review were to assure that the plans and schedules for tests were compatible with the Project plans and schedules, and that the resources required from other elements of the Project could be provided to support those tests. At that time, there was a review of the need for and scope of near-Earth support of the Ground Data System tests, Flight Operations Test and Training tests, and training exercises.

While no major changes to the test plan resulted, several significant Requests For Action were developed. They included requests that: (1) near-Earth support indicate how the aircraft and ship Vanguard crews would be trained for Viking support, (2) near-Earth support determine the best and most timely manner to transfer orbital parameters based on Centaur guidance telemetry data to the Flight Path Analysis Group at the Jet Propulsion Laboratory, and (3) the Tracking Network Operations Analyst determine what action or test run was necessary to demonstrate that Deep Space Stations 42 and 44 in Australia could effectively use the acquisition predicts computed by the Air Force range Real-Time Computer System during personnel training tests and Ground Data System tests, and the Launch. These items were addressed elsewhere in this report.

Viking prelaunch testing began in December 1974 and overlapped the Apollo-Soyuz Test Project prelaunch testing and orbital operations, which terminated July 24, 1975. During this overlap period, there were potential conflicts because of support requirements placed upon the elements of the Near-Earth Support System. These conflicts materialized in only two instances. Because of the limitations of available National Aeronautics and Space Administration communications voice and data circuits between the Cape Canaveral area and Goddard Spaceflight Center, two voice circuits ("Mission Test Computer" and "Status") that had been planned for the Viking Orbiter Precount and the concurrent Near-Earth Telemetry Test No. 5 on April 2, 1975, were forfeited without serious impact upon the test support.

Because of Spaceflight Tracking and Data Network commitments to support the Apollo-Soyuz Countdown Demonstration Test on July 2, 1975, it could not support the Viking Ground Data System Test 8.2 planned for that date. Consequently, the Viking test was rescheduled and conducted on June 30, 1975.

2. Launch Vehicle Telemetry Testing

The launch vehicle telemetry testing primarily consisted of performing data flow checks of the various launch vehicle links (2202.5, 2208.5, and 2287.5) and verifying that the data were processed and displayed properly.

Before these data flow checks were performed, the Air Force Eastern Test Range, Kennedy Space Center, and Spaceflight Tracking and Data Network stations verified that the station software was properly processing the data. Two launch vehicle telemetry magnetic test tapes were primarily used for verifying the launch vehicle software and data flow. These data were processed by Central Instrumentation Facility and displayed on strip charts. Analog data that indicated the launch vehicle measurements and their locations in the data frame were processed by octal callup display and strip charts.

The overall launch vehicle data flow testing accomplished for Viking is shown in Fig. 37. This included stripping out the 33-1/3 bps spacecraft data and sending this data to Building A0.

The launch vehicle telemetry testing consisted of supporting and displaying data from many of the pad tests as well as supporting Ground Data System Tests, and Demonstration and Operational Readiness Tests.

3. Spacecraft Telemetry Testing

Eight spacecraft telemetry tests were performed without any problems being experienced by the facilities.

a. Test No. 1. The first test of four hours verified that (1) the Spaceflight Tracking and Data Network Merritt Island (MIL 71) and Air data and strip out the 33-1/3-bps spacecraft data stream and (2) Merritt Island Telemetry Station and the Automatic Switching Unit at MIL 71 could obtain frame synchronization on the 33-1/3-bps sync pattern. This test utilized the Project-furnished Centaur tapes with the spacecraft 33-1/3-bps data stream with both the Telemetry Station and MIL 71 testing their Pulse Code Modulation Decommulator software and hardware configuration for processing and transmitting the spacecraft data stream.

b. Test No. 2. This was a Simulation System Test to verify that MIL 71 could (1) receive 33-1/3-bps spacecraft engineering data in the Simulation Conversion Assembly from the Viking Mission Control and Computing Center Simulation Center, (2) obtain bit sync lock on the 33-1/3-bps data stream via Channel 1 in the Telemetry and Command Processor, (3) format the bit stream into the standard Deep Space Network High-Speed Data blocks, and (4) demonstrate compatibility with the Mission Control Center computer with spacecraft data input. In this test the Mission Control Center simulation transmitted the 33-1/3-bps data to the Merritt Island Station Simulation Conversion Assembly. The resultant data were routed to the test transmitter through the radio-frequency system to the Telemetry and Command Processor. There the data were processed, reformatted and transmitted

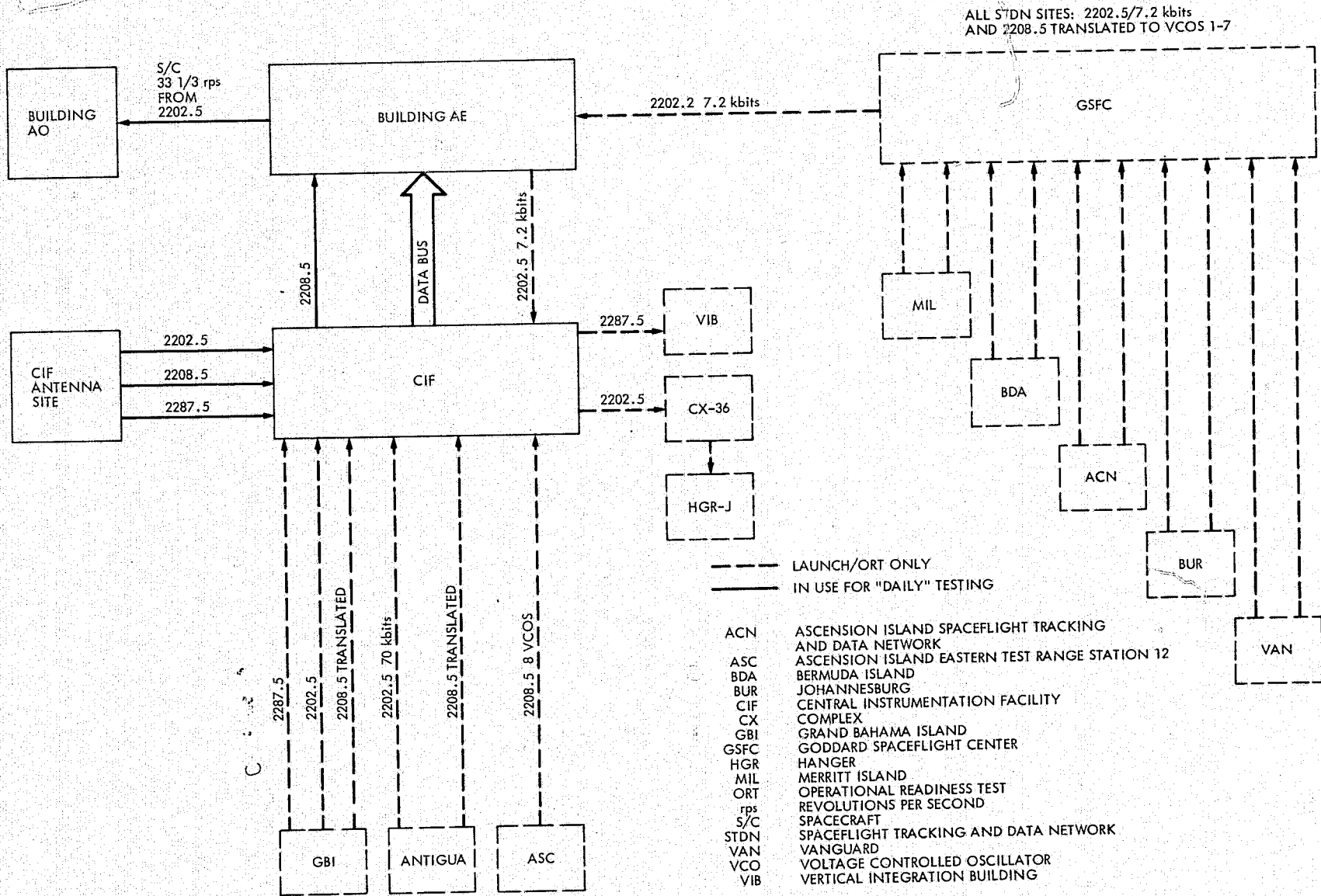

Fig. 37. Launch vehicle real-time telemetry data flow

to the Mission Control Center to obtain frame sync. This test was performed as part of the System Integration Test on 1/9/75.

c. Test No. 3. This was an Air Force Eastern Test Range and Spaceflight Tracking and Data Network Data Transmission Test that demonstrated that each communications link in the retransmission plan could meet a 10^{-3} Bit Error Rate (ber). It also demonstrated that the Telemetry and Command Processor bit sync loop could tolerate the bit jitter induced by these transmission plans. For this test, the Merritt Island Station simulated a 33-1/3 bps spacecraft data stream. The output was routed to Goddard on a 7.2-kbps high-speed line and also to the Air Force Eastern Test Range Merritt Island Telemetry Station. Each of the two sites looped back the data stream to the Merritt Island Station, which verified frame sync on the data stream and performed a bit error test. The test verified that the bit error rate is 10^{-3} or better from both the Goddard Space Flight Center and the Air Force Eastern Test Range Merritt Island Telemetry Station lines.

d. Test No. 4. A Loop Back Demonstration Test showed that the near-Earth facilities did not degrade the simulated 33-1/3-bps data stream generated at the Mission Simulation Center. In this test, the Viking Mission Control and Computing Center generated an uncoded 33-1/3-bps spacecraft engineering data stream and transmitted to the Merritt Island Station on a 4.8-kbps high-speed line. The Station received the data and routed it through its radiofrequency and telemetry system. The spacecraft data were then transmitted to the Viking Mission Control and Computing Center for evaluation. The Station also transmitted the simulated data to Goddard where it was looped back and received at the Automatic Switching Unit. The output of the Automatic Switching Unit was then routed through the standard Deep Space Network Computing Center. The Control Center evaluated and verified that the data were good. The Station then transmitted the simulated data to the telemetry station for loop back and transmission to the Viking Mission Control and Computing Center for evaluation.

e. Test No. 5. The fifth test was an Orbiter Spacecraft/Spaceflight Tracking and Data Network Data System End-to-End Compatibility Validation verifying that the near-Earth data received from an Orbiter Spacecraft were correct when displayed to the Viking Flight Operations System. This test was performed in conjunction with the Viking Orbiter Precount on 4/2/75 from Launch Complex 41.

The Orbiter spacecraft configured and radiated 33-1/3-bps engineering data in the launch format. The Merritt Island Station received the radio-frequency signal and routed the receiver output to the Phase Shift Keying Demodulator/Bit Synchronizer. The output was routed to the Pulse Code Modulation Decommulator for frame synchronization

and to the Automatic Switching Unit. In addition, the radio-frequency receiver output was recorded on analog tape and distributed to the near-Earth support stations for future testing. The Automatic Switching Unit obtained frame sync and outputted the 33-1/3-bps data stream to the standard Network Telemetry System and transmitted to the Mission Control Center via a 4.8 kbps high-speed data line. The data were then evaluated, displayed to the Flight Operations System, and verified as good data.

f. Test No. 6. The sixth test, a Near-Earth/Centaur Data System End-to-End Compatibility Validation, demonstrated that the Near-Earth Compatibility Test Stations (Merritt Island Telemetry Station and Air Force Eastern Test Range) could receive the Centaur 2202.5-MHz pulse-code modulation/frequency modulation signal, decommutate and strip out the 33-1/3-bps spacecraft data stream, and transmit this data to the Control Center via the Merritt Island Station. This test was performed in conjunction with the Terminal Countdown Demonstration test on May 5, 1975.

The Orbiter spacecraft was mated to the Centaur and the 33-1/3-bps engineering data were routed to the Centaur 2202.5-MHz pulse-code modulation/frequency modulation link during this test. The Centaur radiated the 2202.5-MHz link being received at both Merritt Island Telemetry Station and Air Force Eastern Test Range, TEL 4. Both stations received, decommutated, obtained frame sync, recorded on Analog recorder, and transmitted the 33-1/3-bps data stream to the Merritt Island Station. The Merritt Island Station verified frame sync and outputted to the standard Network Telemetry System. Either the Merritt Island Station or Air Force Eastern Test Range Telemetry Station data stream were selected for processing and transmitting the data to the Mission Control Center for evaluation. In addition, analog recordings were made at both sites for duplicating and transmitting the tapes to all the near-Earth stations. These tapes were to be used for future station validation and Mission Operations tests.

g. Test No. 7. Goddard and all its supporting Network stations were verified ready to support the mission test exercises with test 7. Each station generated a 33-1/3-bps engineering data stream from its station simulator for transmission to Goddard for retransmission to the Merritt Island Station for frame sync. Each Spaceflight Tracking and Data Network station then took its simulator off line and played back the analog tape produced from either Test 6 or 7. Each station transmitted to Goddard on a 7.2-kbps high-speed data line and on to the Merritt Island Station via the same route. The Merritt Island Station verified frame sync for each supporting station.

h. Test No. 8. The final test verified that all supporting Air Force Eastern Test Range stations were ready to support the mission test exercises. For this test, each supporting station generated a 33-1/3-bps engineering data stream from its own station simulator, and transmitted the data stream to the Merritt Island Station via 202D modem circuits. The Merritt Island station verified frame sync on each of the stations data stream. Each supporting station terminated the station simulator and played back the analog recording produced from Test 6. The Merritt Island Station verified frame sync on the tape playback data from each station.

4. Metric Data Testing

To test the near-Earth metric data delivery, two metric data verification tests and a Mars B-Plane mapping test were conducted.

The first test verified that simulated metric data from Station 42 in the new Tracking 2-11 format could be processed by the Real-Time Computing Center at the Air Force Eastern Test Range.

After this test was completed, a static data point from the Station was sent to verify that the Real-Time Computing System could process live data.

The Real-Time Computing Center received a frequency constant message that was used as inputs to the Internet Predict Program to generate a specific set of Predicts for Deep Space Network stations. These predicts were generated and sent to the Jet Propulsion Laboratory to be verified by Network Tracking Analysis Team.

The Real-Time Computing Center processed four sets of orbital elements and mapped the orbital elements to the B-Plane at Mars to within a few hundred kilometers. The results also compared favorably with the General Dynamics Convair and TRW mapping of the same orbital elements. The mapping accuracy was considered more than adequate for the purpose intended, and the test was considered successful.

In addition the accuracy and format of all these messages were verified before these data were sent to the Jet Propulsion Laboratory for use in simulations.

5. Support of GDS Testing

The Near-Earth Test Plan called for support by all possible Near-Earth Tracking System elements in a full-up mission system dress rehearsal during Ground Data System Test 8.2. The test had been scheduled for July 2, 1975, which was also the second day of the Apollo-Soyuz Test Project's Countdown Demonstration Test. Because of the imminent Apollo-Soyuz Test Project launch and the Spaceflight Tracking and Data Network's

commitment to support the Countdown Demonstration Test, the Spaceflight Tracking and Data Network advised that it could not support the Viking Ground Data System 8.2 Test as scheduled. Furthermore, the software needed to process the Centaur telemetry data in real time was not yet at all the required sites. It was then decided that no launch vehicle telemetry would be exercised in the Ground Data System 8.2 test.

The test date was advanced to June 30, 1975. Except for launch vehicle telemetry, full near-Earth support was provided. A problem arose at Merritt Island during the Ground Data System 8.2 test in that the telemetry processing computer at the Control Center could not obtain frame sync on any near-Earth tape playback data. All data were being routed from the near-Earth stations to Merritt Island. At this point, the data input to the Automatic Switching Unit for frame sync and output to the DSN TCP experienced bit jitter introduced by tape playback, resulting in garble of the frame sync pattern and data content as it was being formatted in the TCP. Subsequently, with a special configuration for the Symbol Synchronizer Assembly symbol synchronizer loop, the bit jitter generated by tape playback did not affect the data being formatted for high-speed data output. Therefore, this configuration was used for all later testing.

C. FLIGHT OPERATIONS SYSTEM TESTS

1. Flight Operations and Training Tests

Near-Earth resources were used to support flight operations tests with live and/or simulated spacecraft data. Such tests included the System Integration Test, Lander Plugs Out Tests, Orbiter Precount Tests, Lander Prelaunch Tests, Flight Events Demonstration, Terminal Countdown Demonstration, Flight Article Compatibility Tests, Lander Imaging Test, and Lander Cruise Update Tests. The resources consisted mainly of the Spaceflight Tracking and Data Network - Merritt Island Station, the NASA Communications Network circuits, and manpower to monitor and trouble-shoot long-line voice and data circuits. Most tests exceeded 25 hours duration, and caused a considerable stress on the manpower, especially at Merritt Island.

2. Operational Demonstration Tests

These tests demonstrated that the Flight Operations System was capable of executing selected portions of the launch and midcourse maneuver sequence in accordance with the actual mission time line. The time lines for providing spacecraft data from the Merritt Island Station, orbital elements and predict data from the Real-Time Computer System, and mark event, etc., data from Hangar AO were all successfully exercised.

3. Operational Readiness Test

The objective of this test was to demonstrate the final readiness of all the elements of the system for Viking to support the upcoming Viking launches. All elements of the Near-Earth Tracking System supported this test and provided the desired data to the Flight Operations Support areas at Jet Propulsion Laboratory. Only minor problems occurred during the test.

Early in the minus count, Guam had a problem checking out the spacecraft telemetry data flow, but the data were successfully checked out later in the minus count.

The instrumented aircraft scheduled to support the test was not available because the modifications for Viking being made at Patrick Air Force Base had not been completed.

D. FINAL NEAR-EARTH PRELAUNCH OPERATIONS

1. Launch Readiness Review

The Launch Readiness Review was held on July 2, 1975, at the Air Force Eastern Test Range. Members of the review board represented Langley Research Center, Lewis Research Center, Kennedy Space Center, Goddard Space Flight Center, Jet Propulsion Laboratory, and the Air Force Eastern Test Range.

The material was presented in sufficient depth to allow the Board to make a confident judgment of the readiness of the near-Earth facilities to effectively support the remaining Viking tests and operations. The foregoing was predicated upon satisfactory resolution of the Viking Project "Requests for Action," which were not of a critical nature and dealt with launch operations and testing. All these Requests for Action were closed out before the Project Launch Readiness Review.

2. Project Launch Readiness Reviews

The Near-Earth Tracking System supported both the Viking A and B Launch Readiness Reviews. Several were conducted because of the necessity of rescheduling the launch days of both A and B missions because of launch vehicle or spacecraft problems.

The near-Earth status at all the Project Launch Readiness Reviews was "Green" for launch.

3. Near-Earth Launch Constraints and Launch Hold Criteria

The near-Earth support, with the resources planned, could support all the mandatory requirements for both the Viking missions. However,

because of the shortage of near-Earth resources and the fast changing location of the Centaur second burn during the daily launch window, the Near-Earth System could not always be committed to total mandatory coverage for at least an hour window for every launch day. This was well coordinated with the Viking Project Office representative and accepted.

The one near-Earth launch constraint addressed support by the range aircraft. The three range aircraft required a minimum of ten minutes notification of the actual launch time to ensure their proper positioning and subsequent acquisition of launch vehicle and spacecraft data. Without this notification, the aircraft would probably not provide their coverage intervals of mandatory data.

Certain near-Earth mandatory data intervals were considered critical by the Project and, because of this, certain stations were considered launch hold stations if they were unable to support. The stations selected as launch hold stations were coordinated between Project Office, Lewis Research Center (launch vehicle), Jet Propulsion Laboratory (orbiter) and the Near-Earth Tracking System. For the Viking missions, the near-Earth launch hold stations were the telemetry stations at Kennedy Space Center or Merritt Island, Antigua, Ascension, Johannesburg, and one or two range aircraft depending on the launch trajectory. Also, on Mission B, the Vanguard was an additional launch hold station and Ascension was only a launch hold station on certain trajectories.

4. Near-Earth Requirements Which Could Not be Met

All the specified mandatory requirements for the Viking missions could be met for a window of 43 to 85 minutes per day depending on the trajectories. Committed support of several of the Centaur and spacecraft "required" and "desired" requirements after spacecraft separation could not be given because of lack of station views and/or lack of predicted signal strength. The "required" and "desired" data intervals where committed support could not be given is provided in Fig. 16.

III. THE DEEP SPACE NETWORK

A. IMPLEMENTATION

1. Support Capabilities, Configurations

The capabilities of the Deep Space Network were strengthened during the prelaunch period of the Viking Mission. Two new 64-meter stations (Station 43 at Tidbinbilla in Australia and Station 63 at Robledo in Spain) were added. These stations, with Station 14 at Goldstone, formed a new 64-meter subnet. Station 43 was activated in April 1973 and Station 63 in September of the same year. A new 26-meter station became operational in Australia in May 1973 as Station 44 at Honeysuckle Creek. Two 26-meter stations were decommissioned. These were Station 41 at Woomera, Australia, and Station 51 at Johannesburg, South Africa; the first was deactivated January 1, 1973, and the latter as of June 30, 1974. Table 7 lists the deep space stations finally committed to support the Viking Missions to Mars.

From inception to completion, the Viking configuration of the Network was presented in many different forms to suit the background and intended purpose of the recipient. High-level management was interested in only functional capabilities; engineering organizations required overall station layout and electrical interface requirements; operations personnel were concerned with data flow paths, redundant capabilities, and failure mode strategies. Thus many versions of the Viking configuration came into existence to serve particular purposes at particular times and circumstances.

Figure 38 gives the Deep Space Network -- Viking telemetry system baseline functional requirements in a block diagram as published in July 1972 (Ref. 5). Subsequent issues of this technical report described the Tracking, Command, and Test and Training systems (Refs. 6, 7, and 8) at the same level. These diagrams provided a basis on which to verify that all of the required capabilities had been provided for, and from which the engineering divisions could plan and design the actual station hardware and software to be implemented in the network. Examples of Viking configurations as implemented in the 64-meter subnet-work and the 26-meter subnetwork are given in Fig. 39 and 40. These diagrams represent the overall as-build station configurations arranged by subsystem.

For operational purposes, however, the telemetry, command, and tracking data flow paths needed to be separated into clearly identifiable operational configurations that could be disseminated throughout the Network and used by all operational personnel during the Mission. An example of such a diagram is given in Fig. 41, Standard Planetary Configuration (Telemetry) Orbiter/Lander/Orbiter extracted from the Network Operations Plan for Viking. Because there were many such

A. DATA FLOW PATHS

- ① SIMULTANEOUS S-BAND CARRIERS FROM UP TO TWO ORBITERS AND ONE LANDER, EACH CARRYING TWO SUBCARRIERS, THREE CARRIERS PER 64-m DSS; TWO CARRIERS PER 26-m DSS
- ② ORBITER LOW-RATE TELEMETRY DATA, UNCODED, 8-1/3 OR 7-3/4 OR 33-1/3 bps
- ③ LANDER MEDIUM-RATE TELEMETRY DATA, UNCODED 8-1/3 bps OR BLOCK CODED UP TO 1000 bps
- ④ ORBITER HIGH-RATE BLOCK-CODED DATA, UP TO 16.2 kbps OR 4 kbps UNCODED DATA
- ⑤ ILLUSTRATES GROUND AGC AVAILABLE FROM ANY RECEIVER TO 920 COMPUTER FOR TRANSMISSION TO VMCCC WITH TELEMETRY DATA STREAMS
NOTE: THIS INCLUDES X-BAND AGC WHEN EITHER OF BLOCK IV RECEIVERS IS IN X-BAND MODE
- ⑥ OUTPUT OF ALL SUBCARRIER DEMODULATOR ASSEMBLIES IS RECORDED
- ⑦ PLAYBACK OF ANY OR ALL RECORDED SDA OUTPUT
- ⑧ PERIODIC STATUS, SIGNAL-TO-NOISE RATIO CALCULATIONS, DATA/TAPE LOSS ALARMS
- ⑨ DIGITAL RECORDINGS OF 920 AND DATA DECODER ASSEMBLY COMPUTER OUTPUT, PRIME ODR FOR TELEMETRY DATA, REPLAY OF TAPED DATA
- ⑩ UNIVERSAL TIME REFERENCE
- ⑪ REAL-TIME TELEMETRY DATA TRANSMISSION TO VMCCC AND NCS VIA HSS. ALL LOW-RATE AND MEDIUM-RATE DATA STREAMS, INCLUDING DSN TELEMETRY SYSTEM PARTIAL STATUS AND POSTPASS TAPE REPLAYS TO GCF LOG
- ⑫ REAL-TIME TELEMETRY DATA TRANSMISSION TO VMCCC AND NCS VIA WEB. ONE 8-kbps PLUS ONE 16-kbps DATA STREAM FOR DSSs 43 AND 63; TWO 16-kbps DATA STREAMS FROM DSS 14, INCLUDING POSTPASS TAPE REPLAYS TO GCF LOG
- ⑬ TBD
- ⑭ DSS INITIALIZATION CONDITIONS AND TELEMETRY STANDARDS AND LIMITS FROM NCS TO DSS VIA HIGH-SPEED DATA LINE
- ⑮ SPACECRAFT AGC, STATIC PHASE ERROR, AND COMMAND DETECTOR LOCK FROM TELEMETRY DATA TO STATION MONITOR CONSOLE FOR DSN COMMAND SYSTEM OPERATIONS
- ⑯ PREDETECTION RECORDINGS, OUTPUT OF ALL RECEIVERS, NO PLAYBACK CAPABILITY
- ⑰ PROVIDES FOR PROGRAM LOADING AND TRANSFER OF CONTROL INFORMATION FROM TCP COMPUTER TO DDA AND MONITOR INFORMATION FROM DDA TO TCP COMPUTER
- ⑱ TELEMETRY DATA, INCLUDING PARTIAL STATUS, FORMATTED FOR HSDL TRANSMISSION TO VMCCC AND NCS
- ⑲ TELEMETRY DATA, INCLUDING PARTIAL STATUS, FORMATTED FOR WBS TRANSMISSION TO VMCCC AND NCS IN 64-m SUBNET ONLY
- ⑳ TELEMETRY DATA FORMATTED FOR HSS TRANSMISSION
- ㉑ TO ㉔ NOT USED
- ㉕ ROUTING OF ALL REAL-TIME TELEMETRY DATA TO VMCCC VIA HSS FOR DECOMMUTATION, FORMATTING, AND PROCESSING FOR DISPLAY
- ㉖ TELEMETRY REQUESTS TO AND TELEMETRY DISPLAYS FROM NCS DATA PROCESSING FUNCTION
- ㉗ REAL-TIME TELEMETRY DIGITAL DATA FROM DSS TO REAL-TIME MONITORS. REQUESTS FROM THE TELEMETRY DISPLAYS TO DSN OPERATIONS AREA
- ㉘ REQUESTS FROM DSN OPERATIONS FOR TELEMETRY STANDARDS AND LIMITS TRANSMISSION TO DSS
- ㉙ DISPLAYS OF TELEMETRY STANDARDS AND LIMITS DATA TO DSS DSN OPERATIONS
- ㉚ DISPLAYS FROM DSN OPERATIONS FOR RECALL TELEMETRY DATA NETWORK DATA PROCESSING
- ㉛ DISPLAYS TO DSN OPERATIONS DSS OF RECALL TELEMETRY DATA NETWORK DATA PROCESSING
- ㉜ TELEMETRY SIMULATION DATA
- ㉝ TELEMETRY FILL DATA TO PROJECT ON TAPE

B. EQUIPMENT SUBSYSTEM CAPABILITIES

- Ⓐ TBD

C. SOFTWARE CAPABILITIES

- ⓐ TBD

AGC	AUTOMATIC GAIN CONTROL
DSN	DEEP SPACE NETWORK
DSS	DEEP SPACE STATION
GCF	GROUND COMMUNICATIONS FACILITY
HSDL	HIGH-SPEED DATA LINE
HSS	HIGH-SPEED DATA SUBSYSTEM
NCS	NETWORK CONTROL SYSTEM
ODR	ORIGINAL DATA RECORD
OPS	OPERATIONS
SDA	SUBCARRIER DEMODULATOR ASSEMBLY
SPR	SYSTEM PERFORMANCE RECORD
TBD	TO BE DETERMINED
TCP	TELEMETRY AND COMMAND PROCESSOR
VMCCC	VIKING MISSION CONTROL AND COMPUTING CENTER
WBS	WIDEBAND SUBSYSTEM

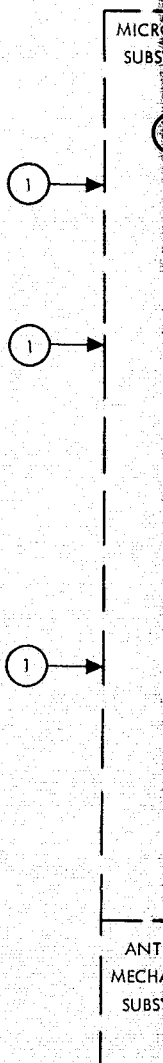

FOLDOUT FRAME

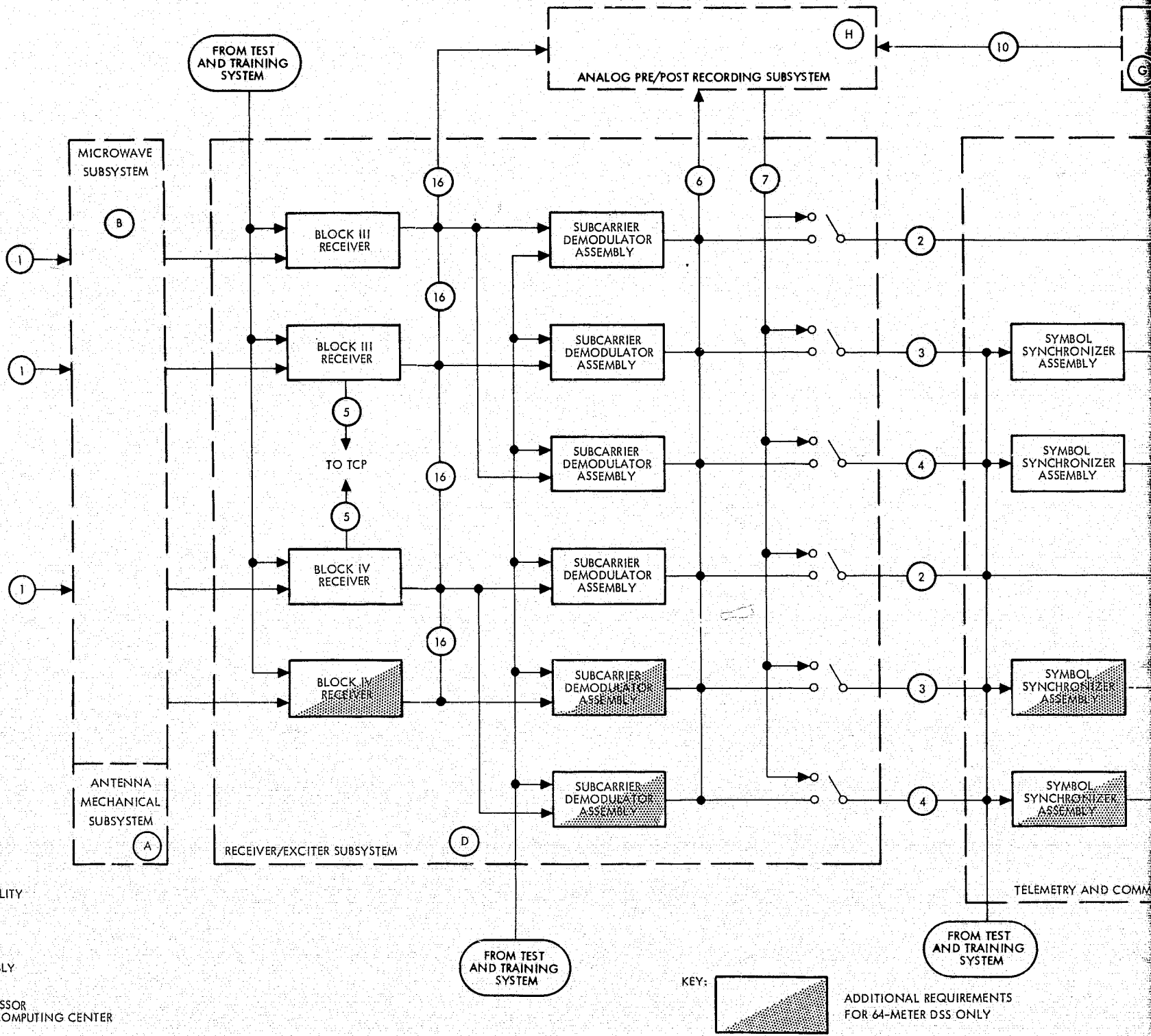

FOLDOUT FRAME 2

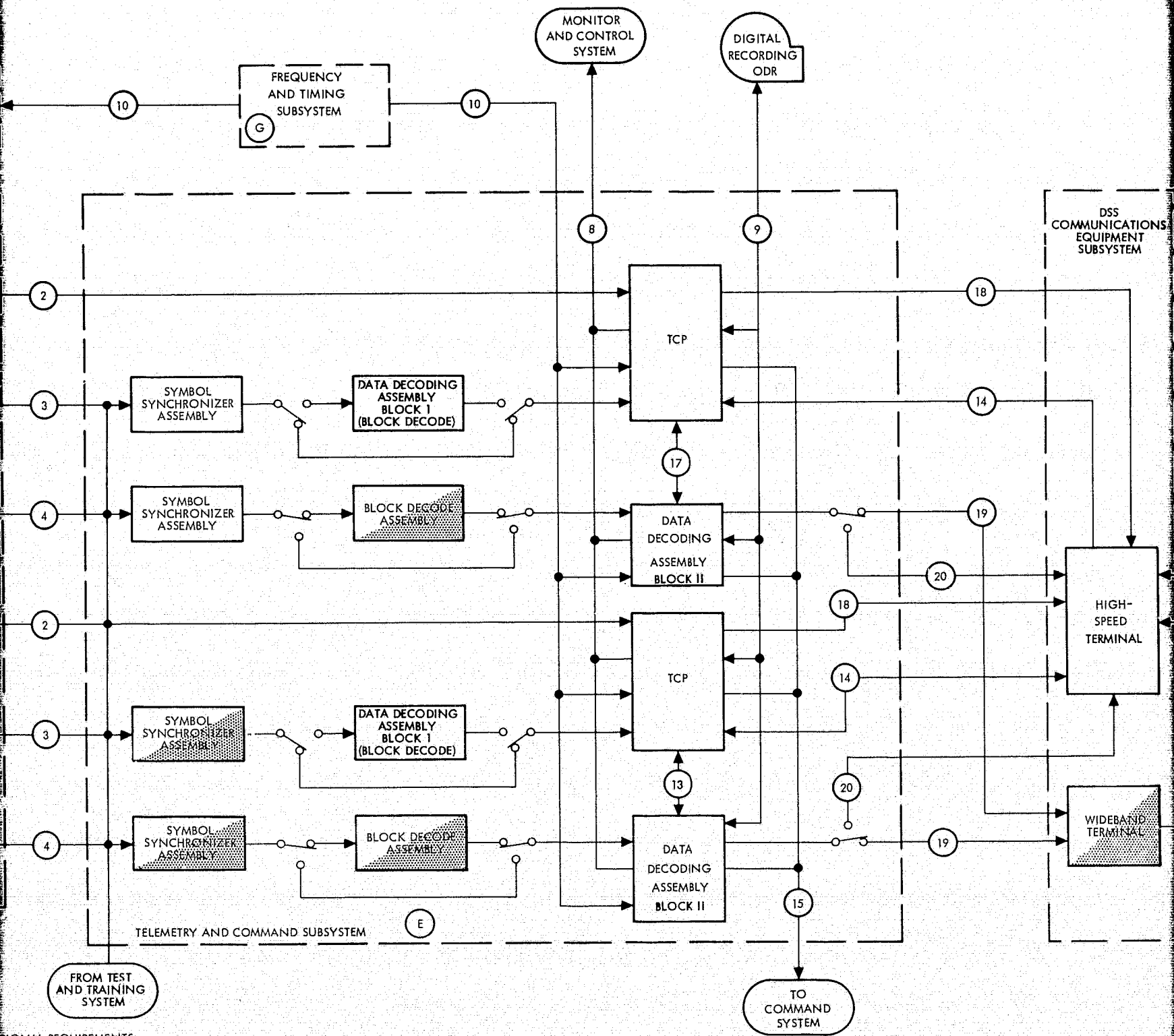

ADDITIONAL REQUIREMENTS
 14-METER DSS ONLY

FOLDOUT FRAME 3

REPRODUCIBILITY OF THE ORIGINAL PAGE IS POOR

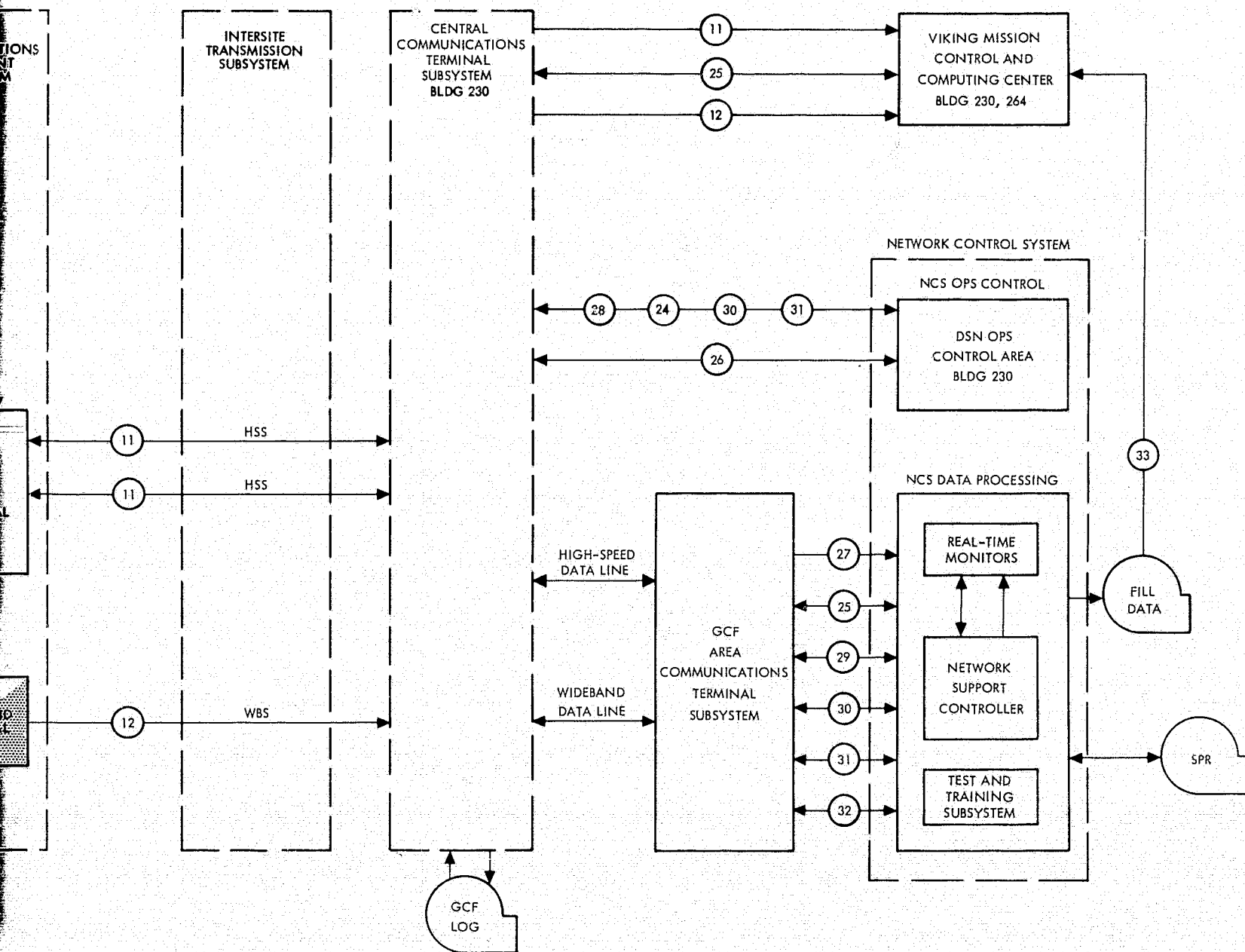
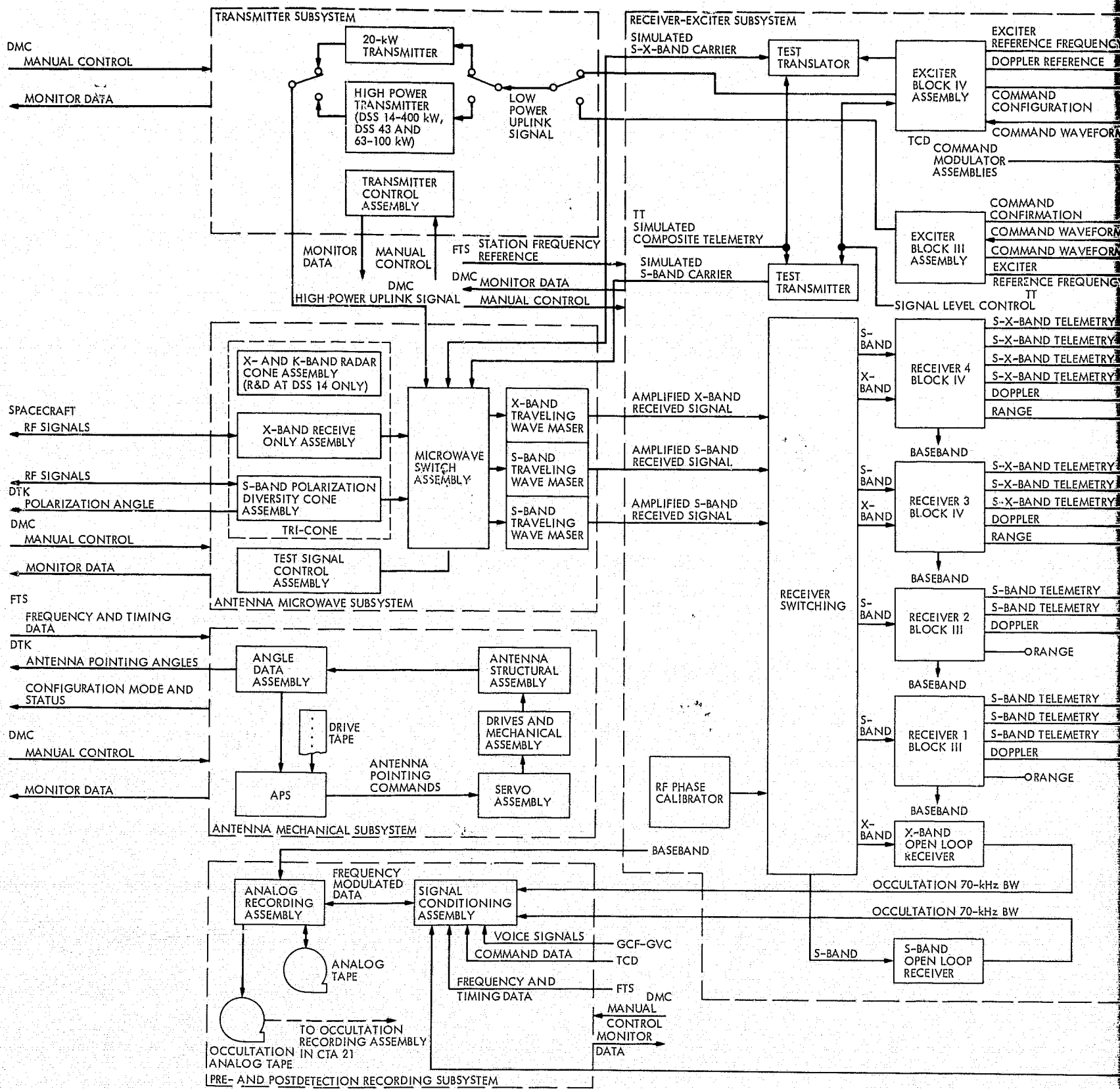
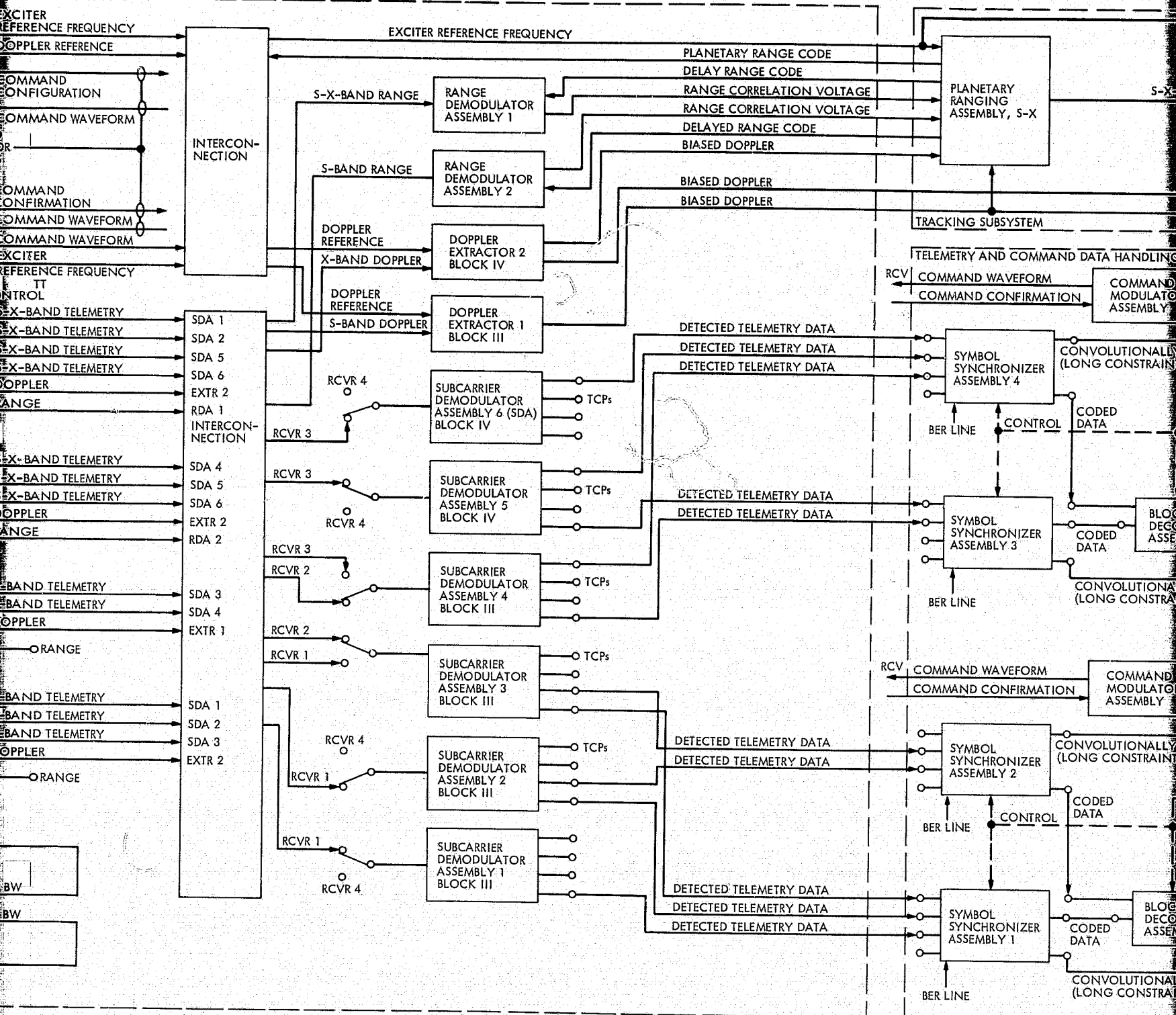

Fig. 38. Deep Space Network/Viking telemetry system baseline functional requirements block diagram.

~~RENDERING PAGE BLANK NOT FILLED~~

FOLDOUT FRAME 4





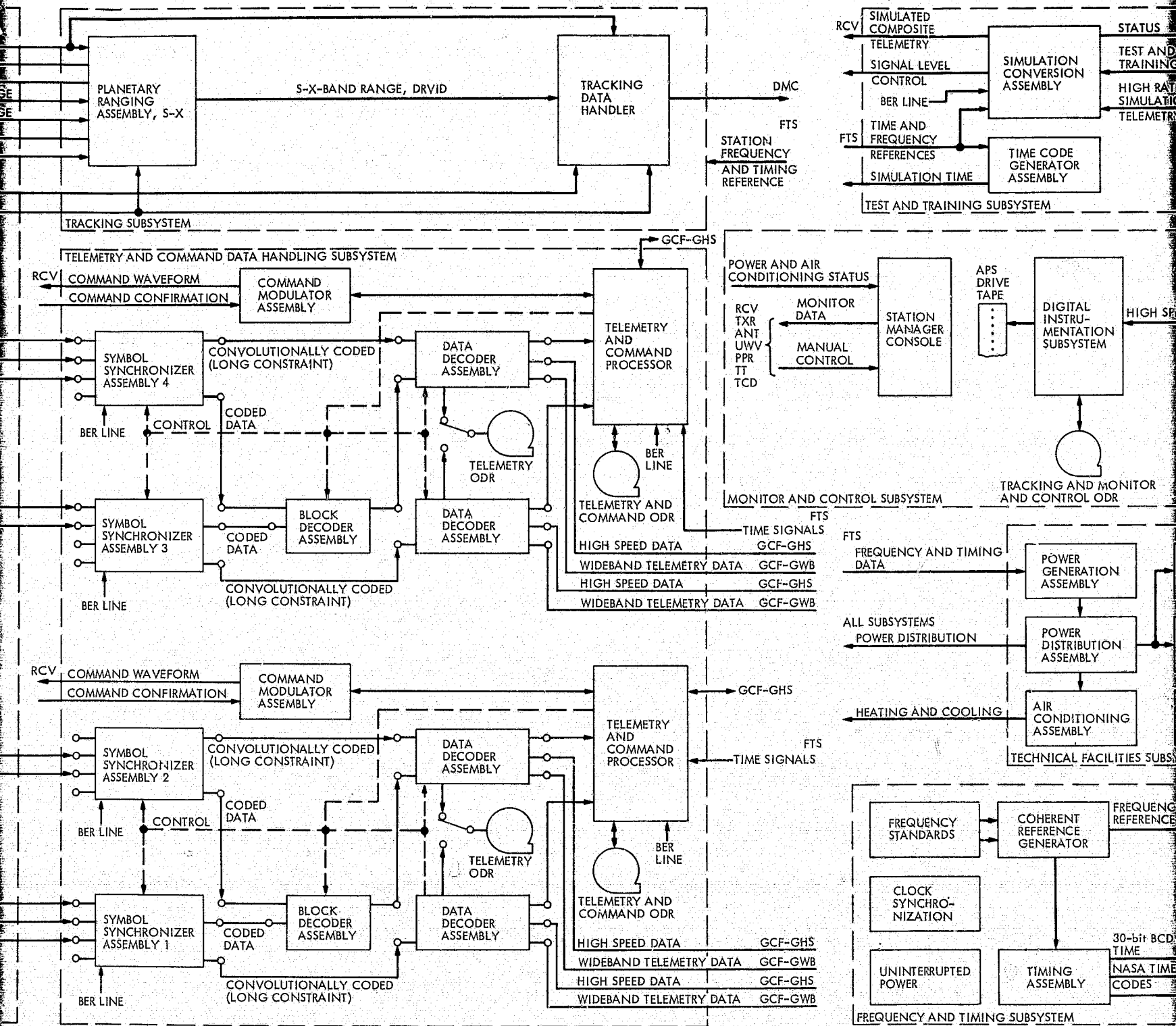

RECORDER TONES

Fig. 39. Deep Space Network Mark III-75

FOLDOUT FRAME

EXCLUDED

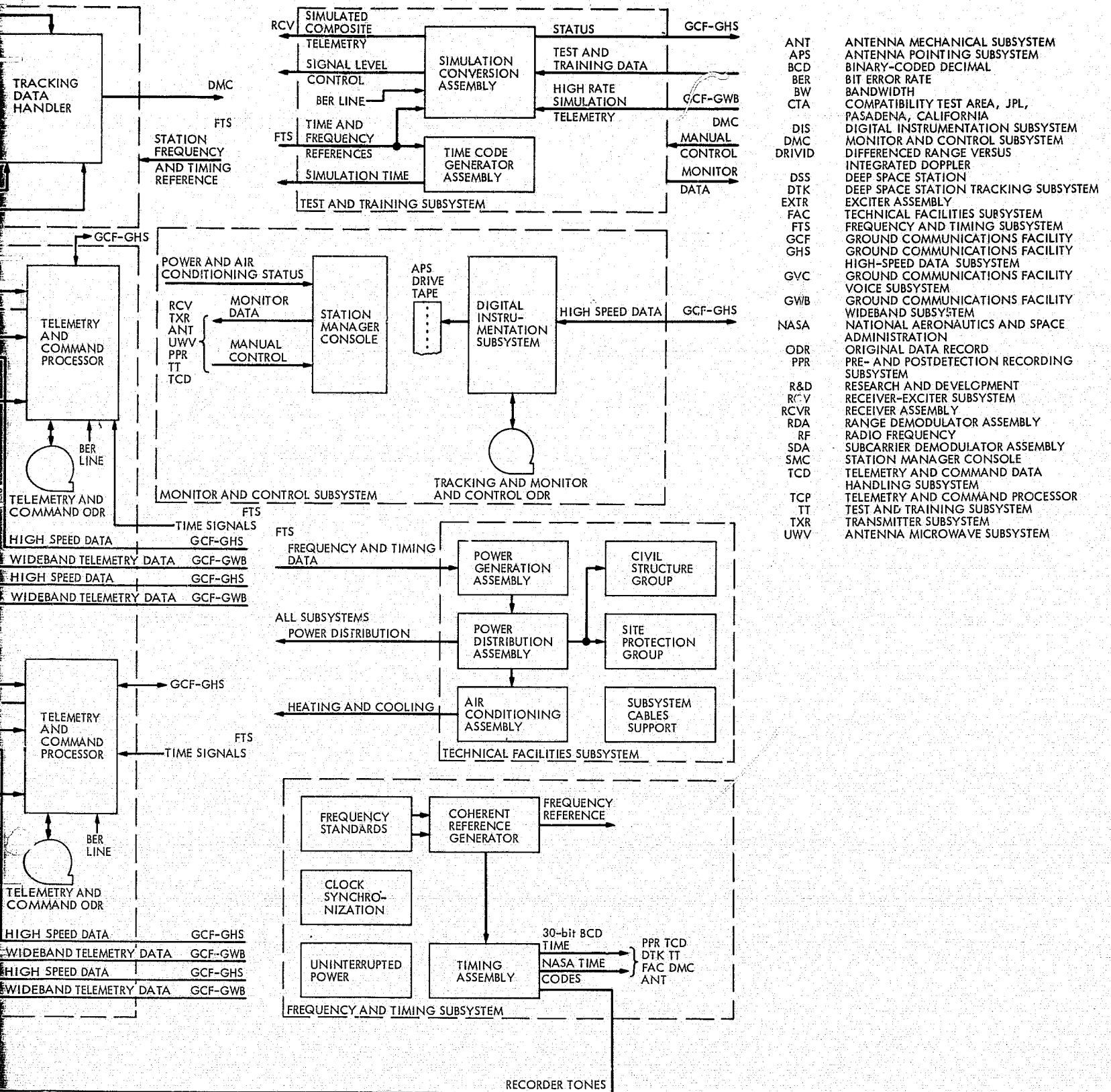
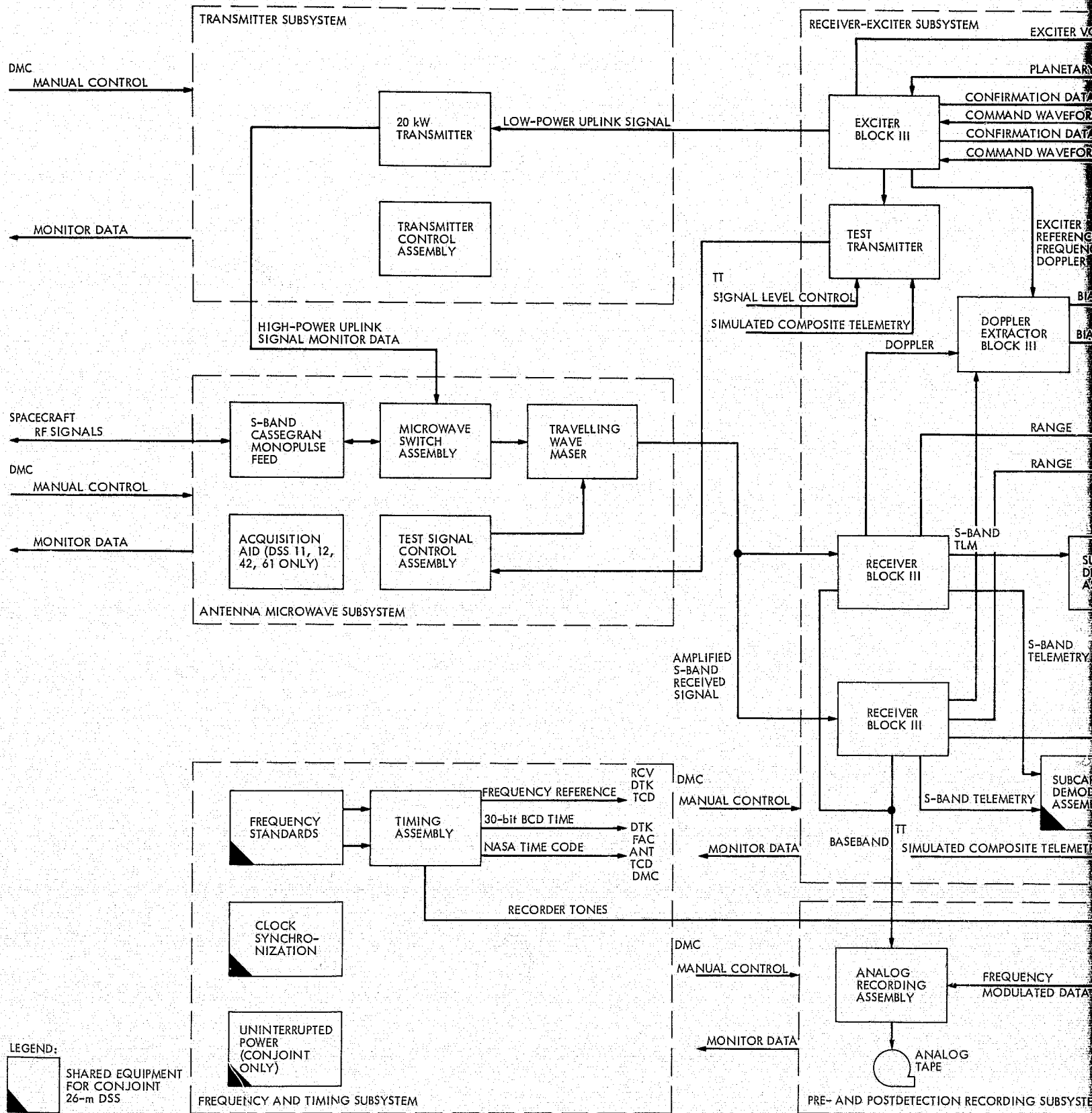
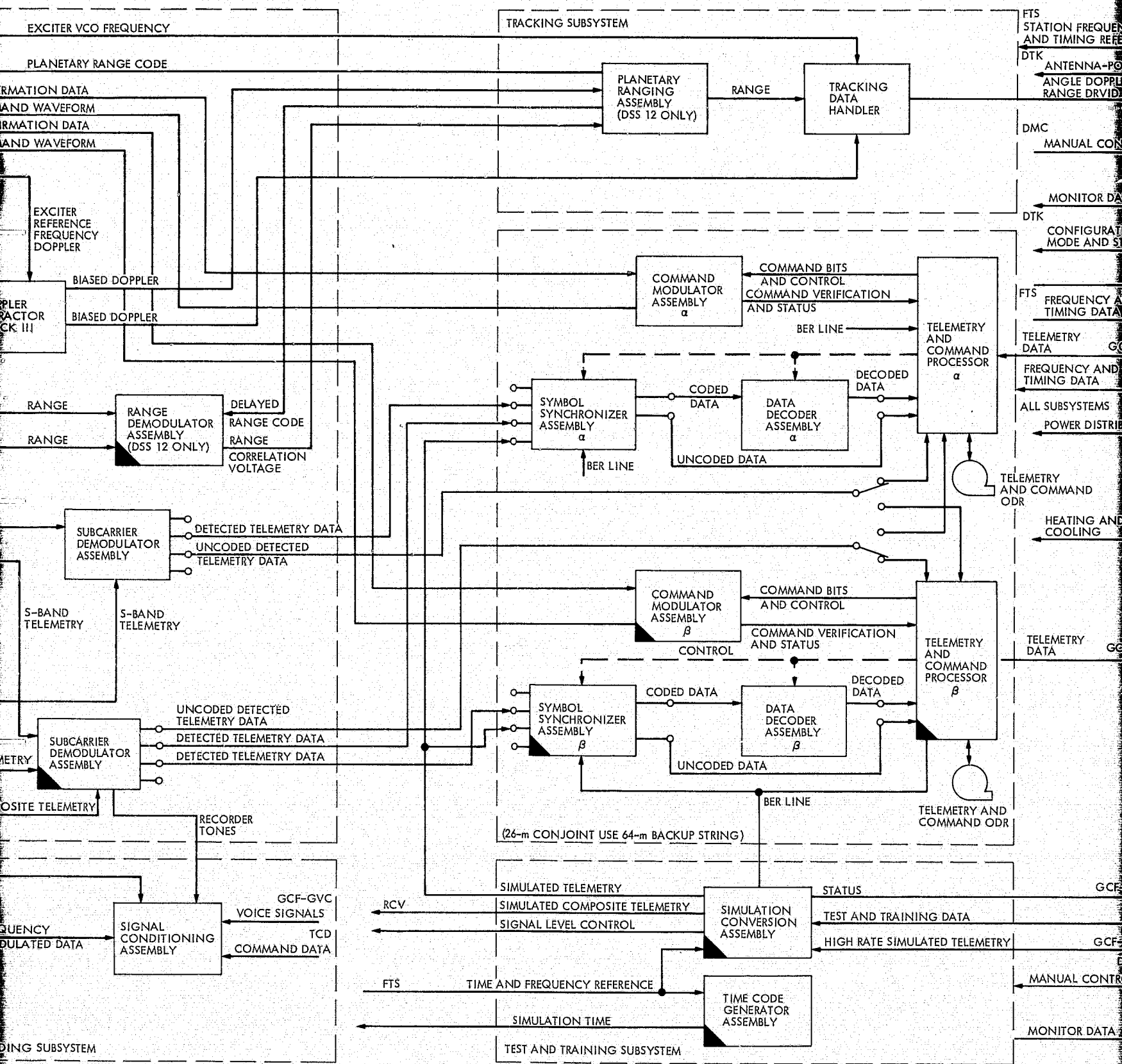
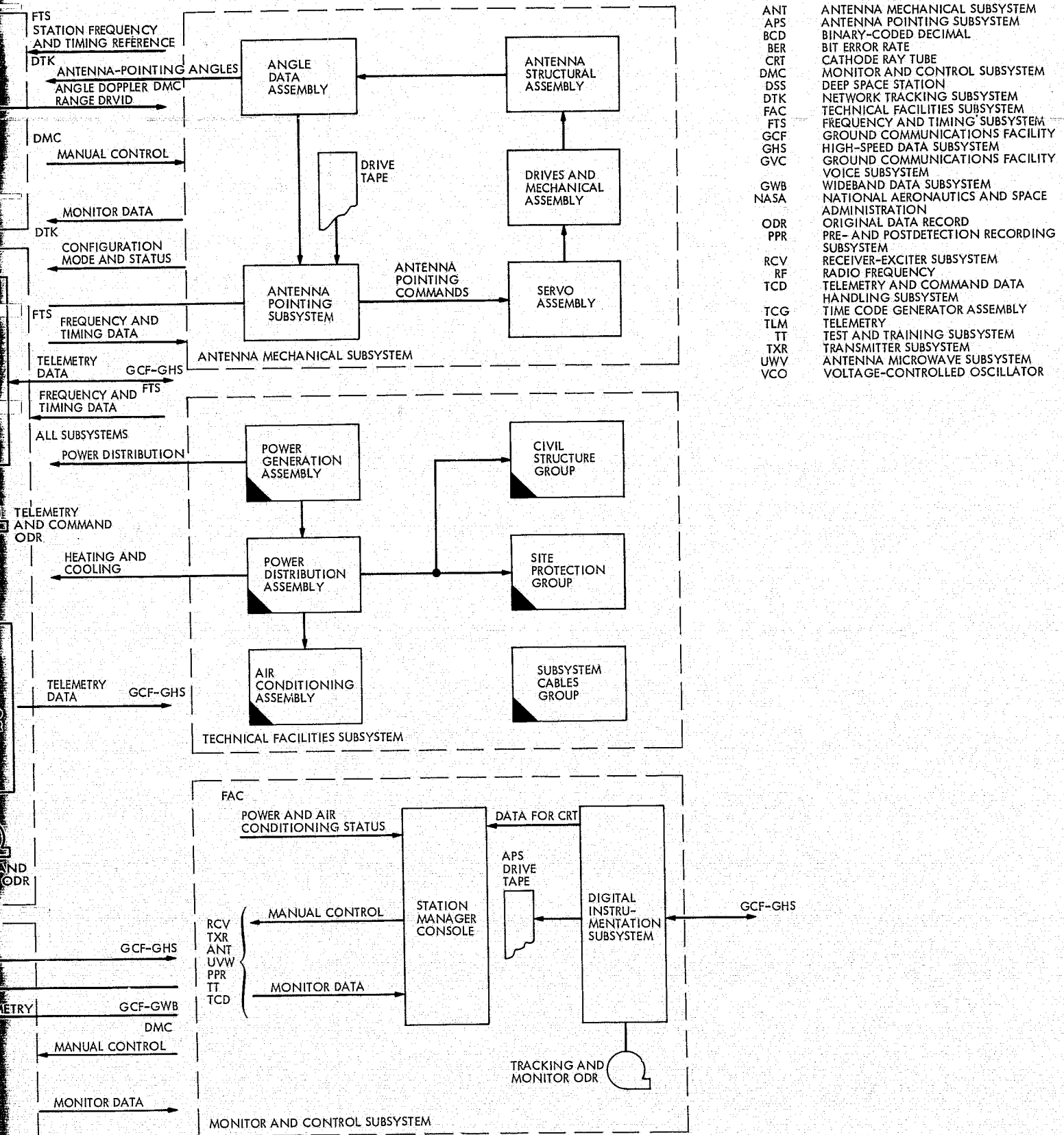

Fig. 39. Deep Space Network Mark III-75 functional network design: 64-meter stations.



FOLDOUT FRAME 1





- ANT ANTENNA MECHANICAL SUBSYSTEM
- APS ANTENNA POINTING SUBSYSTEM
- BCD BINARY-CODED DECIMAL
- BER BIT ERROR RATE
- CRT CATHODE RAY TUBE
- DMC MONITOR AND CONTROL SUBSYSTEM
- DSS DEEP SPACE STATION
- DTK NETWORK TRACKING SUBSYSTEM
- FAC TECHNICAL FACILITIES SUBSYSTEM
- FTS FREQUENCY AND TIMING SUBSYSTEM
- GCF GROUND COMMUNICATIONS FACILITY
- GHS HIGH-SPEED DATA SUBSYSTEM
- GVC GROUND COMMUNICATIONS FACILITY VOICE SUBSYSTEM
- GWB WIDEBAND DATA SUBSYSTEM
- NASA NATIONAL AERONAUTICS AND SPACE ADMINISTRATION
- ODR ORIGINAL DATA RECORD
- PPR PRE- AND POSTDETECTION RECORDING SUBSYSTEM
- RCV RECEIVER-EXCITER SUBSYSTEM
- RF RADIO FREQUENCY
- TCD TELEMETRY AND COMMAND DATA HANDLING SUBSYSTEM
- TCG TIME CODE GENERATOR ASSEMBLY
- TLM TELEMETRY
- TT TEST AND TRAINING SUBSYSTEM
- TXR TRANSMITTER SUBSYSTEM
- UWV ANTENNA MICROWAVE SUBSYSTEM
- VCO VOLTAGE-CONTROLLED OSCILLATOR

Fig. 40. Deep Space Network Mark III-75 functional network design: 26-meter stations

ENCLOSING PAGE BLANK NOT FI

FOLDOUT FRAME 3

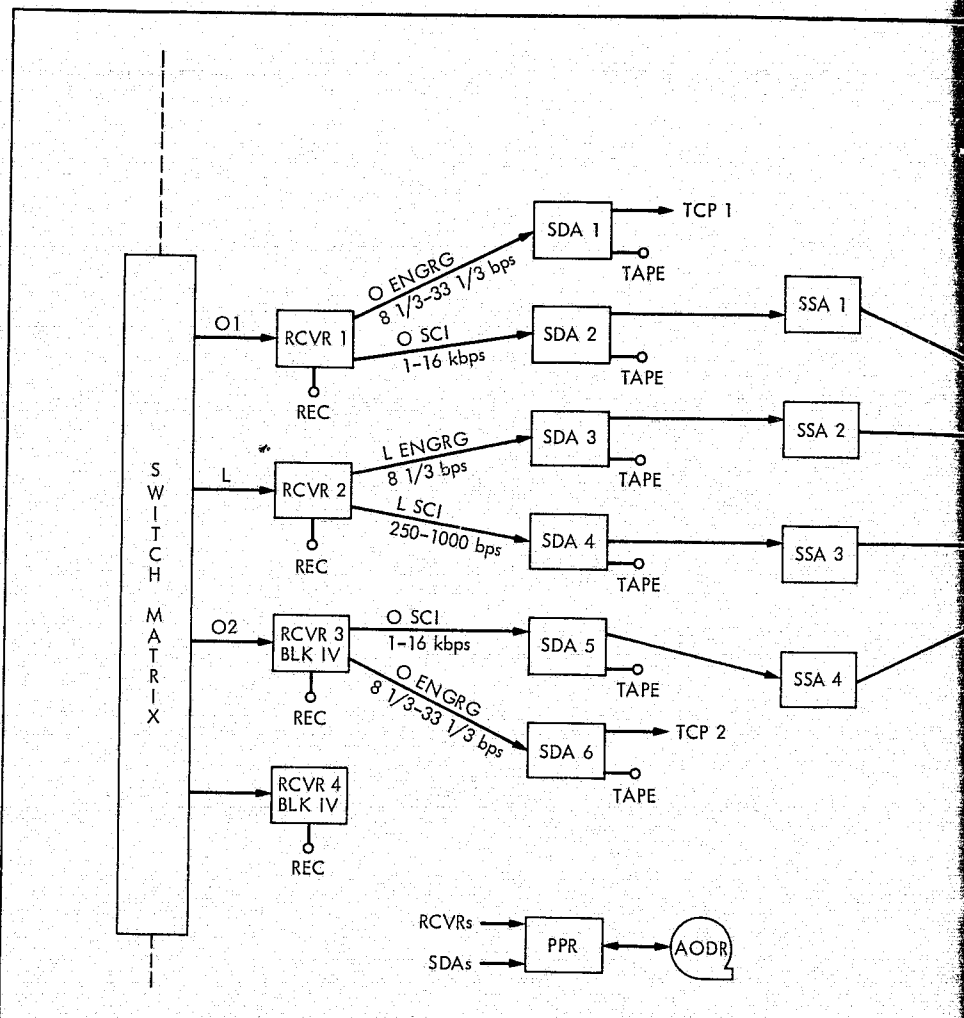

CODE	SPACECRAFT	RECEIVER	DATA TYPE	SDA	SSA	BDA	DDA
30	ORBITER 1	1	ENGRG	1	0	0	0
			SCI	2	1	1	1
	LANDER	2	ENGRG	3	2	0	2
			SCI	4	3	0	3
	ORBITER 2	3	SCI	5	4	2	4
			ENGRG	6	0	0	0

FOLDOUT FRAME

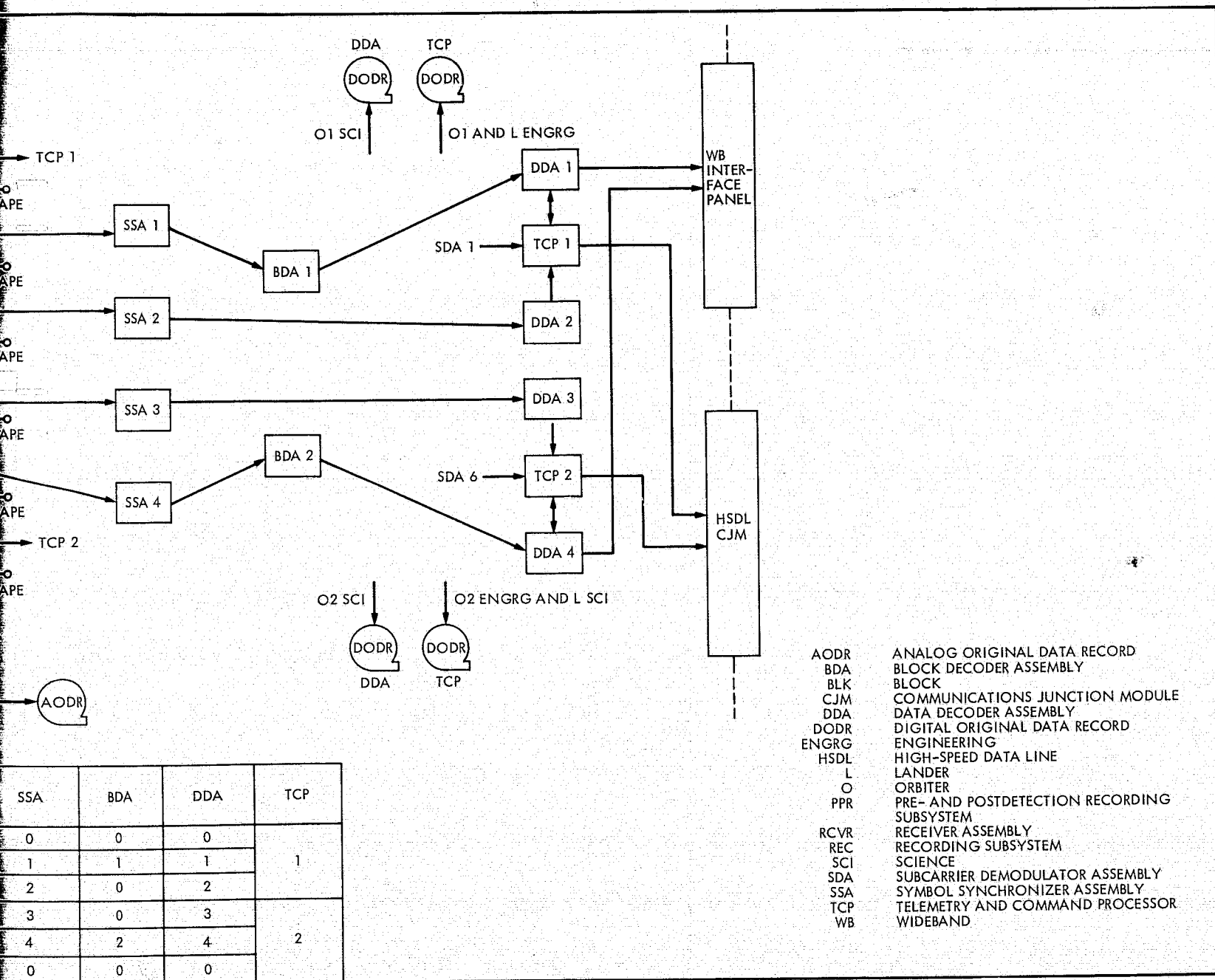

Fig. 41. Standard planetary configuration, Orbiter/Lander/Orbiter - Code 30

ENDING PAGE BLANK NOT FILLED

diagrams required to meet all of the various configurations of orbiters, landers, bit rates, mission modes, etc., these configurations were coded for easy reference throughout the Network. Similar diagrams were also developed for Tracking, Command, and Test and Training, and Monitor and Control.

It should be understood that the process of Viking implementation was essentially one of addition and modification. Except for Network Stations 43 (Australia) and 63 (Spain), and the Network Operations Control Center, all the facilities had been in existence and had supported many previous flight projects in more or less the same form prior to the inception of Viking. Further, the network configuration required for launch and early cruise (up to February 1976) was substantially that which already existed, the major increase being for the start of Project testing in the full planetary configuration after February 1976, but well before planetary encounter in June 1976.

Therefore, the actual implementation was carried out in phases corresponding to the phases of mission activity for which it had to provide support. The phases were reflected in the Engineering Change Order management process by attaching a category letter to each order designating the approximate mission implementation phase as described in Part A.

A summary of the total Viking capabilities that were to be implemented is given in Table 9.

Prior to March 1972, Network implementation plans had included the Space Flight Operations Facility as it was at that time a part of the Network. Following the Tracking and Data/Office of Computing and Information Systems reorganization in March, Network schedules were rearranged to encompass only implementation of the tracking stations, compatibility test stations, ground communications, and the Network Operations Control Center.

During 1972 and 1973, implementation activity for Viking was relatively small because of the replanning of Viking 73 to a 1975 mission and the attention to the Mariner Venus Mercury mission.

By September 1973, however, implementation for Compatibility Test Area 21 had begun to move forward and the longer range Viking implementation was finally planned. The Tracking and Data System level schedule for September 1973 is shown in Fig. 42, to illustrate the situation confronting the Network at that time.

Breadboard design compatibility tests had been run in Test Area 21 for radio frequency only, and the emphasis was on completing Test Area implementation to start the multiple spacecraft compatibility tests described later.

PRECEDING PAGE BLANK NOT FILMED

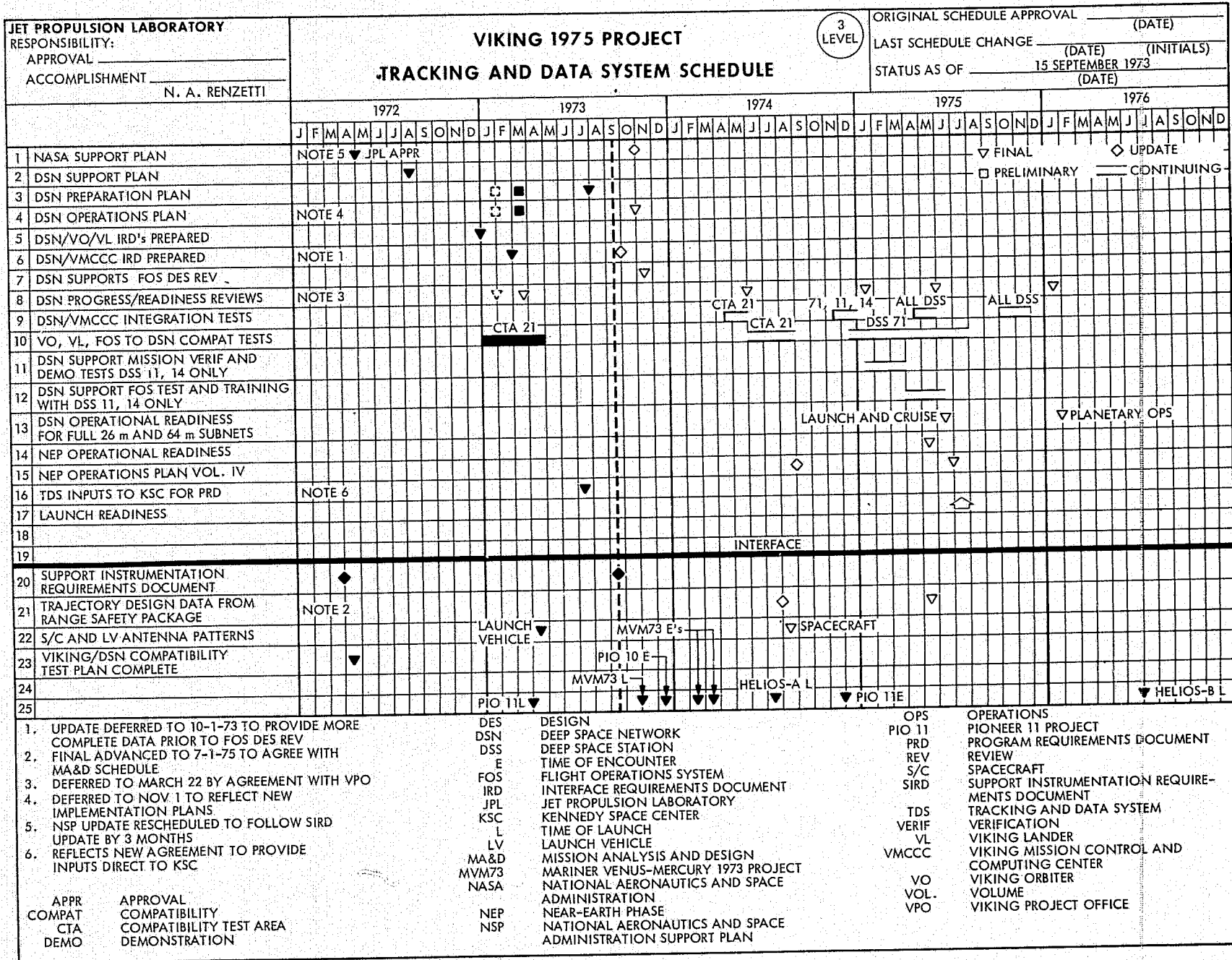

Fig. 42. Tracking and Data System Level 3 Schedule as of September 1973

Table 9. Deep space station capabilities required for Viking planetary support

26-meter Deep Space Stations

Stations 11, 42, 61, 12, 44, and 62 antennas

Single command uplink, 20 kW

One low-rate, plus one medium-rate telemetry data stream

S-band ranging at Stations 11, 42/43 shared, and 61/63 shared

S-band doppler each station

One high-speed ground communications channel

Digital Original Data Record with automatic recall

Analog Original Data Record with station replay

64-meter Deep Space Stations

Stations 14, 43, and 63 antennas

Single command uplink 20 kW prime, 100 kW/400 kW backup

Up to six low, medium, and high-rate telemetry data streams

S- and X-band ranging

S- and X-band doppler

One high-speed and one wideband ground communications channel

Digital Original Data Record with automatic recall

Analog Original Data Record with station replay

S- and X-band occultation data receive and record

S-band very long baseline interferometry data receive and record Stations 14, and 42

Table 9 (contd)

Ground Communications

50-kbps wideband channel to Station 14
27.6-kbps wideband channel to Stations 43 and 63
4800-bps high-speed channels to all stations
Circuit performance monitoring and error detecting

Network Operations Control Center

Automatic recall capability
Intermediate data record production
Network system performance monitoring, display, and data system validation
Tracking performance modification
Network Operations Control

Mars Radar

Uses developmental hardware and software
Provides X-band transmit and receive
Up to 400 kW transmitter power desired

By August 1974, as shown in Fig. 43, both the radio frequency compatibility tests and Data System capability tests had been completed using two orbiter streams, and one lander stream simultaneously between Compatibility Test Area 21 and the Mission Control Center. In the course of these tests, up to six data streams had been passed across the interface to the Control Center and processed satisfactorily, simultaneously with generation of two command links. This completed implementation at Test Area 21. Implementation at Station 71, Merritt Island, and Station 14 at Goldstone for support later in the year was in progress.

The end of the year saw the Block IV receiver installed and tested at Spaceflight Tracking and Data Network -- Merritt Island 71, and the first System Integration Tests with the Control Center,

completed the implementation at that Station. Block IV receivers for Stations 43 and 63 were in production and expected to be installed prior to launch, construction of facilities for the overseas high power transmitter installations were about complete at the Spanish site, while the Australian contractor was about to begin work at Tidbinbilla. During May 1975, the Goldstone Stations 14 and 11 implementation in the planetary configuration had been completed to support the Performance Verification Tests. These tests pointed out areas in the Network configuration needing improvement, particularly in regard to Analog Original Data Records and Digital Original Data Records.

Implications of providing support from the second 26-meter subnetwork had been evaluated and some impact on the plan to implement the Station Monitor and Control Assemblies system at these stations had been identified. The System level 3 schedule for July 1975 is shown in Fig. 44. By that time, the Block IV receivers were installed and tested at Stations 43 (Australia) and 63 (Spain). The high-power transmitter was expected to be complete in August at Station 63, and November at 43. All implementation and testing required for launch was completed by July 22 with the exception of some antenna noise abatement work on the Australian station antenna, which had been delayed by bad weather at the site. This was, however, accomplished by 0800 Greenwich Mean Time on August 11, and the Network supported the initial launch attempt with zero anomalies.

Implementation of the planetary configuration at both Stations, 43 and 63, had been slowed somewhat by the application of configuration control during the launch period, but was to resume immediately upon completion of the launch activity.

2. High-Power Transmitter Rationale

Installation of 100-kW transmitters to provide dual uplinks at 10 kW each was an early Viking requirement. This requirement was principally oriented toward the need for simultaneous commanding from a single station to two spacecraft (Orbiter/Orbiter or Orbiter/Lander). However, early in 1973 indications were that the dual-carrier, single-transmitter mode of operation presented technical problems that were not fully understood. Recommendation was made that the dual-carrier mode be considered as a "mission enhancement" feature only in all future mission planning. The prime mission mode was to be based on the use of two subnets, with the simultaneous command longitude. However, evaluation of the consequent impact on the Viking mission planning and flight support showed that, irrespective of the dual-carrier requirement, there remained a need for a 100-kW transmit capability at Stations 43 and 63, as well as the 400-kW transmit capability at Station 14 at Goldstone, to avoid unacceptable risks and/or constraints to Viking Lander operations (Mission B particularly).

These risks could result from (1) worst-case telecommunications performance, (2) adverse landing slopes (30 deg), (3) random Lander orientation, (4) high-gain antenna or computer malfunction, (5) southerly landing sites (30 deg S), (6) need for real-time targeting of landing site, and (7) late launch in the secondary mission.

The dominant factors influencing all these effects were Lander low-gain antenna patterns measured on a 3/8-scale model. These patterns showed severe distortion due to adjacent hardware on the Lander structure, which resulted in large negative gain over substantial portions of the antenna field of view. Most of the conditions described above could result in Earth-look vectors that lie in these negative gain areas. Hence, they required a high-gain transmit capability to compensate for the antenna gain deficiencies.

These data (Ref. 9) were presented in overview by the Martin Marietta Corporation at the Viking Lander Critical Design Review in Denver on September 18-20, 1973, and in detail to the Viking Telecommunications Working Group at Martin Marietta in Denver on September 21. Both organizations, as well as the Viking Project Manager, agreed that the 100-kW transmit capability at the overseas stations was a necessary element in the Network support planned for the Viking mission. Accordingly, a revision to the Viking Support Instrumentation Requirements Document deleted the dualcarrier requirement, but restated the requirements for the 100-kW capability at Stations 43 and 63 for the purposes described above. Implementation of this capability then was reinstated and as operational date of January 1, 1976, was set.

3. Technical, Operational Difficulties

Apart from the usual technical and operational problems associated with a major implementation project, the single largest problem with prelaunch preparation resulted from the slip in the implementation completion milestone at Deep Space Station 14.

The 26-meter stations needed relatively minor hardware additions for Viking, but the 64-meter stations required extensive equipment installations. The overseas 64-meter stations (Australia 43 and Spain 63) were not scheduled to be fully implemented for Viking until after launch. Station 14, however, was scheduled to be fully implemented to support the Project prelaunch planetary tests.

The implementation completion milestone for Station 14 was originally scheduled for September 15, 1974. It first moved to mid-October, then mid-November, early December, and finally to January 4, 1975. This total slip of 3-1/2 months was caused in part by the station being out of service for approximately one month to reconfigure for a Helios launch, the Pioneer 11 Jupiter encounter, and the time needed for the substantial number of the engineering changes needed to meet the Viking configuration.

In April 1974, the high-power (100-kW) transmitter at Station 14 had to be shut down for approximately four weeks for major rework and modification. This modification included installation of a new Klystron to raise the maximum power to 400 kW. Bearing regROUT and numerous Viking modifications also caused a shutdown of the station for a period in September 1974. Station 63 was taken off-line for the entire month of October so that the elevation drive motor gear boxes could be removed and reworked. Earlier that year (August) time was spent at DSS 63 to add an X-band cone.

To prepare for the Viking mission and to support a Saturn radar experiment in December 1974, it was necessary to replace all of the feed cones at Station 14. The feed cone used for the Pioneer 10 encounter was a prototype, the polarization diversity S-band cone. This cone was replaced in September 1974 with the standard S-band polarization diversity cone, which was more nearly identical to the operational cones at Station 43 in Australia and Station 63 in Spain. After temporary installation of the X-band receive only cone for the purposes of fitting the associated dichroic plate and ellipsoid required for Viking S and X-Band, the cone was removed and the S-band megawatt transmit cone reinstalled so that Pioneer would have a backup S-band capability in the event of a failure in the newly installed cone.

In August 1974, modification of Station 44 in Australia to the standard Deep Space Network configuration began. This called for changes in the antenna as well as the addition of an Antenna Pointing System, Digital Instrumentation, and Tracking and Data Handling subsystems. The station control area also was relocated from Tidbinbilla to Honeysuckle Creek. The station was not operational again until January 13, 1975.

B. NETWORK OPERATIONS TRAINING

The unique operational requirements of the Viking Mission created a need to emphasize personnel training throughout the Network. This training was divided into two types, Mission Independent Training and Mission Dependent Training.

Mission independent training, although normally not a part of a Mission Test and Training Plan, was a prerequisite to Viking oriented training and testing. The majority of the subsystems to be used during the mission remained unchanged from previous missions. However, the Viking configurations required up to six full telemetry streams and two command streams and one command stream as for previous missions. Training data and documentation for the new equipment was supplied to the Network Training Unit Supervisor by the Cognizant Operations Engineers of the affected subsystems. A training package was prepared and sent along with the new equipment to the locations involved.

The mission dependent training consisted of classroom instruction and training exercises conducted at each facility. Also included were "in-house" operational tests designed by the Facility Director, who acted as training controller, to exercise the Viking configuration.

A comprehensive training package was also provided each station by the Network Operations Project Engineer to assist in this phase of training. The package included lists of Viking Lander and Orbiter commands, from which the stations produced Mylar command tapes for their use, and also instructions for operator training in manual command exercises. All Viking unique computer "type-ins" for standard operations, plus those used for troubleshooting and failure isolation and recovery, were included for use in conjunction with the Standard Operations Procedures and the procedures in the Network Operations Plan for the mission. There was to be particular emphasis on the voice backup command procedures and manual Telemetry and Command Subsystem configuration and initialization. Station on-site training tests were to be accomplished with the Simulator Conversion Assembly as a self-contained Viking spacecraft telemetry simulator, using the fixed pattern data tapes supplied by the Network Operations Project Engineer.

C. TESTING AT COMPATIBILITY TEST AREA 21

1. Activity Summary

The Network Compatibility Test Area 21 at Pasadena played a major role in the Viking test program during 1974. These series of tests included System Integration Tests, Telecommunications Compatibility Tests, and Design Compatibility Tests. With completion of this testing at Test Area 21, the Deep Space Network and Viking Project were ready to begin system verification testing using the Merritt Island Station at Cape Canaveral, Florida, and to verify continued Network-Flight Project interface compatibility with flight spacecraft before the 1975 launches.

Project policy called for testing of interfaces between adjacent systems of its six-system structure. Thus, early in 1974, a series of System Integration Tests began with the Viking Orbiter System, Viking Lander System, Launch and Flight Operations System, Viking Mission and Control Computing Center System, and the Tracking and Data System.

From April 6 through June 24, 1974, twelve system integration tests in which multiple data streams were passed between the Stations and the Control Center were performed. The test data streams simulated real data types and data rates, and were handled by all of the hardware and software in the Station and Control Center in exactly the same way as real data. Network and Control Center performances in generating, handling, and processing the data were considered a measure of the readiness of the entire Ground Data System to enter live mission support.

During the summer of 1974, the system test phase of the telecommunications compatibility test program was completed. These tests provided the basis for the establishment of telecommunications system design compatibility between the Network, the Viking Lander and Viking Orbiter, and a simulated Network-multiple spacecraft configuration for the Mars planetary orbital operations. Subsystem design compatibility tests were successfully completed during 1973, while system verification was to be performed in Florida in 1975.

The system phase of the telecommunications compatibility test program also served as a basis for requirements for five Design Compatibility Tests that were performed successfully between July 15 and August 14, 1974.

Previous to the above testing, the Viking Lander system development model was shipped to Jet Propulsion Laboratory (March 1973) for development compatibility tests with the Network in Compatibility Test Area 21. Four weeks of radio frequency tests were completed at that time in both the single and dual-uplink environment without any anomalies being detected. No further tests with the Viking Lander were then required until June 1974 when the Lander was, as noted, again brought to Test Area 21 to begin the final radio frequency compatibility test series in conjunction with the Viking Orbiter.

2. System Integration Tests

These tests were conducted in four phases: (1) test of the Network - Control Center interface for Lander telemetry, (2) test of the interface for Orbiter telemetry, (3) test of the interface for the Viking Lander - Viking Orbiter command, and (4) test of all functional interfaces simultaneously with maximum loading. The Viking configurations for Test Area 21 used for telemetry and command tests are shown in Figs. 45 and 46.

Overall responsibility for conduct of the integration testing was assigned to a Test Conductor provided by the Control Center. The Network Operations Project Engineer acted as coordinator for the Network. He was supported by the Network Control System and the Network Analysis Group.

Among the problems during the performance of the integration tests were those of dual commanding, bit stream anomalies in the 1-kbps science data, timing problems between the Control Center Simulation Center and the Ground Communications Facility in testing high-rate Orbiter data, and failure in maximum loading at 16-kbps playback from the Orbiter. These problems are reported in the following System Integration Test summary.

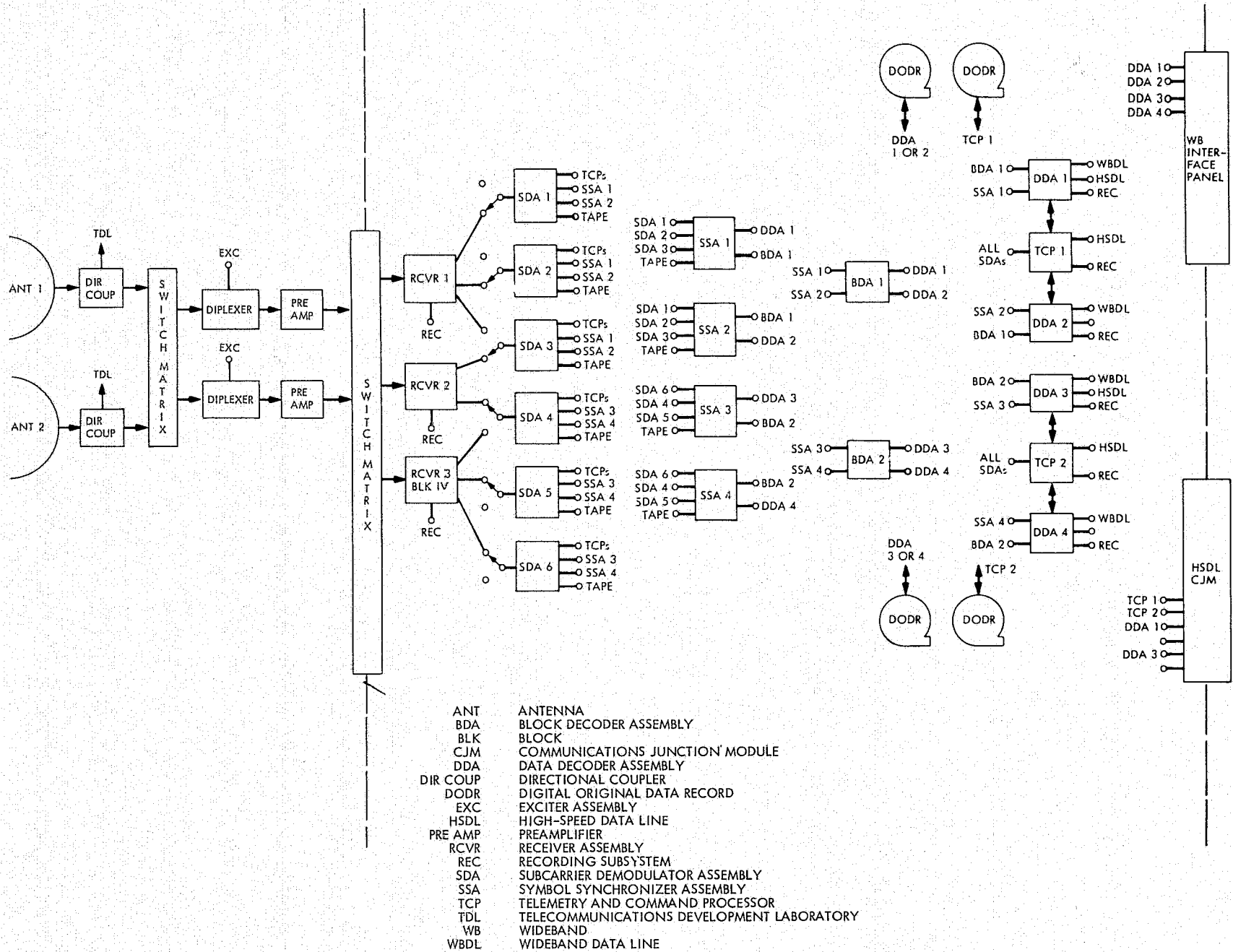

Fig. 45. Compatibility Test Area 21 Viking telemetry configuration

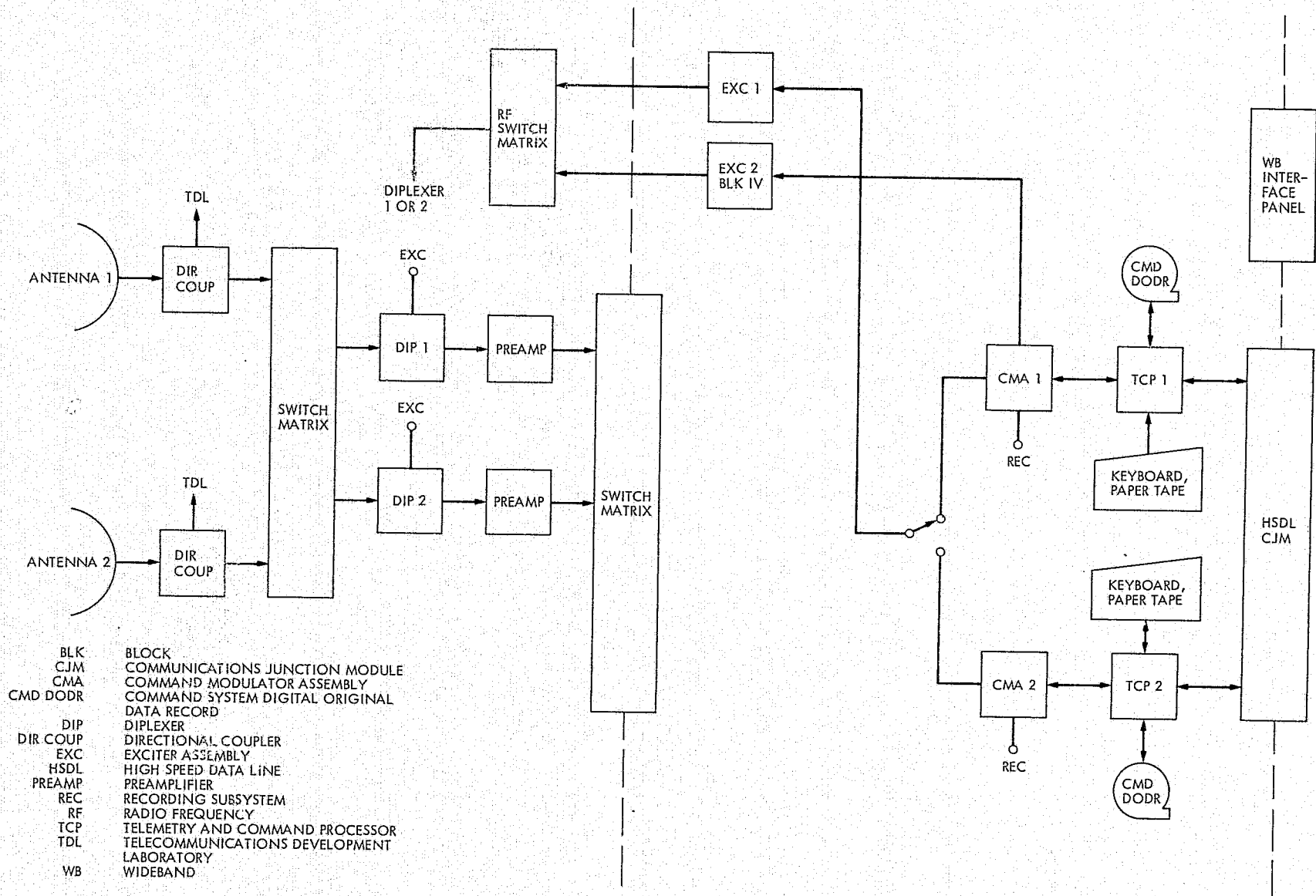

Fig. 46. Compatibility Test Area 21 Viking command configuration

a. Dual Commanding. Although a standard station configuration provided that only a single spacecraft be commanded at any specific time, Test Area 21 required dual command capability to satisfactorily conduct compatibility testing. The first attempt to achieve this on May 1 failed, and the only retest of the series was required.

At the time of System Integration Test No. 7, Test Area 21's second exciter (Block IV) was not fully implemented, and the hardware and software workarounds to use the Block III exciter failed because the exciters could not be emulated. However, on the May 10 retest dual commanding was accomplished. In addition, the Lander telemetry interfaces operating in parallel with the command interfaces were verified. Lander direct data at 8-1/3 bps and 250 bps were successfully processed.

On May 1 the unfinished portion of the Test 5 (April 23) sequence that called for dual Lander command interface verification in both the automatic and manual modes was completed. In completing the sequence, dual command was simulated by simultaneously conducting "in core" Orbiter commanding in the 360/75 computer. Orbiter commanding objectives were the same for Test 6 (April 26) as the Lander objectives of Test 5. Test 6 objectives were met and the test sequence completed.

b. Data Stream Anomaly. During the Test 7 rerun, a Lander science data bit stream anomaly previously observed in Tests 1 and 2 (April 16 and 19) was isolated to the Simulation Center 360/75 computer - Ground Communications Facility interface. In the Test 1 Lander telemetry interface, specified rates were Lander direct engineering data at 8-1/3 bps, science data at 250 and 500 bps, and science playback data at 1 kbps. Thirty-seven of 45 science formats were tested satisfactorily, but the bit stream anomaly appeared on the remainder.

Objectives of Test 2 were to verify the telemetry interface while processing three Lander telemetry data streams. With maximum interface loading for Lander 8-1/3-bps engineering, science at 1 kbps, and also Lander data playback from Track 8 of the Orbiter at 16 kbps, format verification was completed on the orbiter science data, and engineering data was processed without problems. Again, as in Test 1, a bit stream anomaly was observed within the 1-kbps science data stream.

c. Timing, Loading Problems. During Test 2, timing problems between the simulation center 360/75 and the Ground Communications Facility precluded effective testing at bit rates in excess of 4 kbps. Although this test included the independent Lander telemetry, maximum loading at 16-kbps playback from the Orbiter was accomplished. This problem, which reoccurred in Tests 3, 4, and 11, was attributed to the simulation center - Ground Communications Facility interface. Orbiter telemetry testing was deferred and replaced with the command testing phase.

In Test 3 (May 4), which was to verify telemetry interfaces for a single Orbiter, the timing problem still existed, but was less evident on the 50-kbps wideband data line. The Mission Test and Computing Facility could not process the high-rate 8-kbps data for time periods greater than approximately 2 minutes, and Test Area 21's Simulation Conversion Assembly could not lock on the 16-kbps data generated from the simulation center.

In Test 4 (May 7), with the loading configuration requiring both Orbiter data streams (33-1/3 bps and 16 kbps) and a Lander science data stream at 1 kbps, the loading objective was met. Yet the 16-kbps data stream could not be sustained by the Control Center simulation center for a period exceeding 1 to 2 minutes. This simulation constraint was isolated to the simulation center 360/75 - Ground Communications Facility interface. Only the 50-kbps wideband data line was exercised during the test.

The second phase of Test 11 on June 8 (two Orbiters and Lander telemetry and command) simulated all the nominal data interfaces to be used during a planetary or full loading pass from an overseas station. It was required that the 28.5-kbps wideband data line interfaces be exercised by processing two Orbiter high-rate data streams simultaneously at 16 and 18 kbps. The configuration operated successfully, but data processing at Mission Control Center could not be sustained while using the 28.5-kbps wideband data lines. This was considered a Mission Test Computer problem and not related to the Telemetry and Command Subsystem or Ground Communications Facility. All high-rate data streams were generated by Test Area 21's Simulation Conversion Assembly as the simulation center - Ground Communications Facility problems had not been resolved. Test 11 verified the multiple spacecraft telemetry and command data at maximum data rates, processed simultaneously. The Telemetry and Command Processors were able to process data at maximum loading (one 8-1/3-bps and two 16-kbps Orbiter data streams) while commanding the Lander from one Telemetry and Command Processor and the Orbiter from the other. The configuration simulated all the nominal data interfaces, including monitor data, that were expected during a planetary pass.

On June 1, Test 10 (two Orbiters and Lander telemetry) verified the interfaces could handle the loading of multiple spacecraft telemetry data streams at maximum bit rates. The simulation center generated all of the high-speed telemetry data rates, while Test Area 21's Simulation Conversion Assembly generated the wideband data rates. The Control Center simulation center high-speed data streams were 8-1/3 bps, 33-1/3 bps, and 1 kbps. Test Area 21 produced 16-kbps wideband data streams using the Simulation Conversion Assembly in the stand-alone mode. Using the high-speed data lines and the 50-kbps wideband data line, the data rates were all successfully processed.

The System Integration Tests closed on June 24 with Test 12, which was a repeat of Test 11. Conducted in four phases, the test was successful in parts of the first and second phases: (1) transfer

and process six telemetry data streams in real time using the 28.5-kbps wideband line and the high-speed data line, and (2) replay the 7- and 9-track Digital Original Data Record recorded during Phase 1 while continuing to process real-time data in one Telemetry and Command Data string. Neither a repeat of Phase 1 using the 50-kbps wideband line nor a repeat of Phase 2 for data recorded during Phase 3 was successful.

d. Ground Data System Test. The principal difference between the System Integration Tests and a related Ground Data System 1 test on July 1 was the use of as much of the Ground Data System as possible. In this test, verification of end-to-end telemetry processing of the Orbiter and Lander data rates was sought. However, during the short-loop high-speed wideband portion of the test, problems with wideband simulation thwarted test objectives. It was determined by checking out wideband communications hardware (Ground Communications and Mission Control and Computing Facility) that a problem existed in the Mission Control and Computing Facility (software) operating system that resulted in only the first 40 bits of each 2400-bit wideband data block being saved for use by other programs. A software correction was made in real time and data were correctly processed in short-loop configuration. A retest was performed successfully July 20 to complete the test objectives. The Telemetry and Command Systems were successfully tested with the minor problems experienced being corrected.

It was then concluded as a result of the System Integration Tests and related Ground Data System testing that the Network and Control Center were ready to support the Data System Compatibility test effort.

3. Design Compatibility Tests

Five Design Compatibility Tests were successfully completed from July 3 to August 14, 1974. They provided an end-to-end verification of the integrity of the Ground Data System design under typical mission loading conditions. Starting with the modulated radio frequency carriers' input to Compatibility Test Area 21, the data were sequentially processed through the stations, passed across the Ground Communications Facility to the Control Center, and finally displayed in the Mission Support Area. Maximum loading conditions were established that included six simultaneous telemetry data streams, two command streams, one monitor and one tracking data stream during the testing.

The test configurations were: (1) Lander direct link telemetry and command; (2) Orbiter telemetry and command; (3) spacecraft telemetry and command; (4) Lander relay telemetry and command; and (5) two Orbiters and Lander telemetry and command.

The first attempt on July 15, in configuration (1) failed to demonstrate that Ground Data System design was compatible with Lander S-band direct link telemetry and command capability. On the retest two days later, all objectives were met, with all Lander data rates (8-1/3, 250, 500 bps, and 1 kbps) successfully processed simultaneously with commands.

All objectives were met for configuration (2) on July 21 with telemetry data rates 8-1/3, 33-1/3 bps and 1, 2, 4, 8, and 16 kbps being simultaneously processed with Orbiter commands.

After demonstration (July 22) that commands were transmitted to the mated spacecraft with verification and evaluation via the downlink telemetry streams in configuration (3), the uplink phase of the test was completed August 8. Telemetry data in the mated configuration at data rates (8-1/3 and 33-1/3 bps; 1 and 2 kbps) were processed simultaneously with commanding.

Ground Data System compatibility with Orbiter telemetry data containing both prerecorded Track 8 and real-time telemetry data relayed from the Lander in configuration (4) was demonstrated August 14. Telemetry data rates 8-1/3, 33-1/3 bps, and 1, 2, 4, 8, and 16 kbps for the prerecorded data, as well as telemetry data at 8-1/3 and 33-1/3 bps, and 4 kbps, uncoded, were processed. Orbiter commanding was conducted simultaneously with the telemetry processing. A failure of Channel 2 of the Telemetry and Command Processor at Test Area 21 did not compromise the tests because the redundant computer was put into use.

Demonstration that the Ground Data System was compatible with multispacecraft environment in configuration (5) was completed in a two-day test (July 31-August 1). Six simultaneous telemetry streams (two at 8-1/3 bps, one at 33-1/3 bps, two at 16 kbps, and one at 1 kbps) were successfully processed simultaneously with Lander and Orbiter commanding. Minor problems (the result of inadequate time for transfer tests prior to test start) were caused in simulation of one 8-1/3-bps data stream and the processing of 8-1/3-bps data.

4. Spacecraft Telecommunications Compatibility Tests

System level testing of the Network-Viking Project Telecommunications Test program was completed during the summer of 1974 at Jet Propulsion Laboratory. The detailed results of the test program are given in Ref. 10. The testing was between Compatibility Test Area 21, which simulated a Deep Space Station, and the Viking proof test Orbiter, the spacecraft test Lander, and a simulated multiple spacecraft configuration. For the later configuration, the Orbiter and Lander were located in the Spacecraft Assembly Facility. A radio frequency transmitter in the screen room at Test Area 21 simulated the second Orbiter S-band downlink.

Ground station procedures and test design criteria and test parameters were prepared by the Network. Spacecraft telecommunications design performance criteria and test parameters were prepared by the respective Orbiter-Lander telecommunication teams. All test procedures, which included test parameters and performance criteria, were approved jointly by the Network and Flight Project representatives under the direction of the Viking Telecommunications Working Group.

These tests, whose objectives included establishment of prerequisite data bases for performing the Design Compatibility Tests described in paragraph 3 above, are discussed separately here.

a. Network-Viking Spacecraft Test Lander Compatibility. For the Lander tests, the spacecraft test Lander was located in the screened room of the Spacecraft Assembly Facility and Test Area 21 was configured to represent a Network 64-meter station. An S-band radio frequency air link was established between the spacecraft test Lander and Test Area 21. The Network established a pretest calibration of this air link to an amplitude stability of ± 0.2 dB. The program used in the tests was the released version of the telemetry and command software, which was to be used to support the mission.

This program was (1) to prove telecommunications design compatibility between the Network and the Viking spacecraft test Lander in accordance with the Master Integrated Test Plan; (2) to prove Network single spacecraft performance prior to the conducting of the multiple spacecraft radio frequency compatibility tests; and (3) to provide prerequisite data bases for performing the data compatibility tests (1 through 5), which establish flow system interface compatibility from the spacecraft via the Network to the Control Center.

Sixty hours of testing established telecommunications systems design compatibility between the Lander spacecraft and the Network, and also proved Network-single performance prior to the conducting of the multiple spacecraft radio frequency compatibility tests. The detailed results of the tests are given in Ref. 10.

b. Deep Space Network-Viking Proof Test Orbiter Compatibility. The Orbiter proof test spacecraft was located in the Space Simulator building 150 and the S/X-band radio frequency links were established to Test Area 21 for these tests. Both the S- and X-band links were calibrated by the Network, and radio-frequency amplitude stability was established for a 3-sigma measurement of 0.2 dB for S-band and 1.0 dB for X-band. With the exception of Block IV receiver/exciter (an engineering prototype), the Test Area 21 was configured to simulate a 64-meter station using operational hardware and Telemetry and Command Subsystem software.

The objectives of these tests were: (1) to establish Network/Viking Orbiter telecommunications compatibility for telemetry, command, tracking, and metric data in accordance with the Viking Project Master Integrated Test Plan; (2) to provide baseline criteria for analysis of the multiple carrier interference effects in the multiple spacecraft radio frequency compatibility tests; and (3) to provide prerequisite data bases for performing data compatibility tests.

Ninety hours of testing established Network-Viking Orbiter telecommunications compatibility for telemetry, command, tracking, and metric data. It also provided baseline criteria for analysis of the multiple carrier interference effects in the multiple spacecraft RF compatibility tests. There was excellent coordination between the spacecraft and this test area despite the compatibility testing being a second priority in the Spacecraft Simulator. Detailed test results are given in Ref. 12.

c. Deep Space Network-Viking Multiple Spacecraft Compatibility.

The test spacecraft Orbiter and Lander were located in the Spacecraft Assembly Facility during these tests. A test transmitter, to simulate the second Orbiter with an S-band radio-frequency downlink capability only, was installed in the screen room of Test Area 21. S/X-band radio-frequency air links were established between the Orbiter spacecraft and Test Area 21, while interface with the Lander was established with an S-band radio-frequency air link between Test Area 21 and the Spacecraft Assembly Facility. To support these tests, Test Area 21 provided two simultaneous S-band uplinks and received and processed telemetry data from three simultaneous downlinks.

The objectives of the compatibility tests were: (1) to verify the performance and operational capability of the Network in a multiple downlink carrier environment; (2) to ascertain the performance of the Orbiter and Lander under predicted radio frequency interface conditions; and (3) to provide baseline criteria as a prerequisite to conducting the multiple spacecraft data compatibility tests (DCT-5).

d. Test Description. In addition to the standard compatibility tests with all radio frequencies at their nominal rest values, the following tests were performed to simulate the potential frequencies of the flight spacecraft under expected doppler effects and S-band power levels during Mars orbital operations. These special radio frequency interference tests are described below. (The proof test Orbiter was on radio-frequency Channel 9, the spacecraft test Lander was on radio-frequency Channel 13, and the test transmitter was assigned to radio-frequency Channel 20.)

- (1) False uplink acquisition with ranging: with S-band radio-frequency Channels 13 and 20 uplinks adjusted to expected Orbiter radio-frequency received levels at Mars distances, ranging modulation was applied to Channel 13 uplink, and the uplink was swept through the assigned Lander channel. The Orbiter was observed for acquisition of a ranging sideband, with subsequent loss of downlink radio-frequency lock.
- (2) False command acquisition with ranging: a single, Channel 20 uplink was tuned to a specified offset from the assigned channel frequency. Command and ranging modulation were then applied, and the carrier was swept through Channel 20. The Orbiter was observed for radio-frequency and command

acquisition, and the Lander was observed for radio-frequency acquisition.

- (3) Radio metric degradation with ranging: with the Orbiter and Lander both in the two-way mode, the Lander uplink was set to an expected Orbiter radio-frequency received level, and ranging acquisitions of the Orbiter were conducted to obtain reference performance data. The Lander uplink (Channel 13) was then tuned to a specified offset from the assigned channel frequency. Ranging modulation was applied to the Channel 13 uplink, and the uplink was swept through the frequency band. During the sweep of Channel 13 uplink, continuous ranging acquisitions of the Orbiter were obtained, and data were analyzed for variations in range delay.
- (4) Viking Lander telemetry degradation by the Viking Orbiter high-rate telemetry: with the Orbiter and Lander both in the two-way mode, a baseline telemetry performance test was conducted. The Orbiter uplink was then tuned to specified frequency offsets, and all telemetry channels, at each frequency offset, were observed for performance degradation.
- (5) Command and telemetry degradation with ranging: with the Orbiter and Lander both in the two-way mode, one Lander uplink was set to an expected radio-frequency Orbiter received level, and continuous commands were sent to the Orbiter to obtain reference performance data. The Lander uplink (Channel 13) was then tuned to a specified offset from the assigned channel frequency. Ranging modulation was applied to the Channel 13 uplink, and the uplink was swept through the frequency band. The Orbiter was observed for loss-of-uplink lock, command anomalies, and telemetry degradation.

e. Test Results. The results of the 40 hours of tests established telecommunications system design compatibility between the Viking multiple spacecraft and the Network. The following comments describe test results from the series of special radio-frequency interference tests reported above.

In the special tests, radio frequencies selected to generate radio-frequency interference represent considerable offsets from assigned center frequency values. However, each of those frequencies is considered possible during the mission. The total offset from assigned center frequency was derived from consideration of the voltage-controlled oscillator drift, temperature effects, and orbital doppler shift. The absolute value of the frequency offset for each test is provided in the discussion below.

Interference from ranging sidebands will occur only during range acquisitions. Immediately following a range acquisition, the code is advanced to the clock component (C_1) only, and all sidebands around higher-order components disappear.

The following are the results from the special test (False uplink radio-frequency acquisition with ranging) described in d(1). The Orbiter uplink (Channel 9) was acquired by the fifth sideband of the second ranging component on the Lander uplink (Channel 13) at a signal level of -137 dBm. The Orbiter was also acquired by the tenth sideband of the third ranging component at a signal level of -150 dBm. These results were as predicted from theoretical analysis. For this test, the Channel 13 uplink was inadvertently set 9 dB below the expected value. The expected interfering levels are, therefore, 9 dB higher than those observed in the test. The frequency offset of Channel 13 was 77.3 kHz below assigned center frequency.

The results of these tests are described in detail in Ref. 10.

5. Conclusions

The Deep Space Network-Viking telecommunications compatibility tests at Compatibility Test Area 21 established that the Network and the Viking Orbiter and Lander telecommunications links had met interface specifications and that no incompatibilities existed. They also provided confidence that if a radio frequency link interference or problem occurred during flight operations, the interference effects would be reasonably well understood. The formal radio-frequency compatibility test program had been completed on schedule as a result of the close coordination and cooperation of the organizations involved.

The next phase of the compatibility test program was scheduled to begin at the Merritt Island Station in late January 1975 after transportation of the flight spacecraft to the launch site at Kennedy Space Center, Cape Canaveral, Florida.

D. SPACEFLIGHT TRACKING AND DATA NETWORK - MERRITT ISLAND TESTING

1. General

Beginning in January 1975 and ending in early July, the Spaceflight Tracking and Data Network - Merritt Island Station MIL-71 participated in a series of Viking spacecraft command and telemetry compatibility tests with communications support by the NASA Network Communications and operational support by the Network Operations Control Center. Separate tests were performed with the Viking Landers and Viking Orbiters and Viking Spacecraft 2 (combined Orbiter and Lander). With these tests, the telecommunications integrity of the flight spacecraft was finally verified.

Data System Tests were also an integral part of the radio frequency compatibility test program, covering equipment configuration and performance, a Systems Integration Test, a Ground Data System Test, Flight-Article Compatibility Tests, Mission Precursor Tests, Communications, and Network Control Center support. The station Command System configuration used for the Data System tests is shown in Fig. 47. Figure 48 shows the Station Telemetry Subsystem configuration for mated-spacecraft tests in which both Lander and Orbiter telemetry was received on the Orbiter downlink. The Station Telemetry Subsystem configuration for the Lander Flight Compatibility Test in which telemetry was received on the Lander direct downlink is given by Fig. 49.

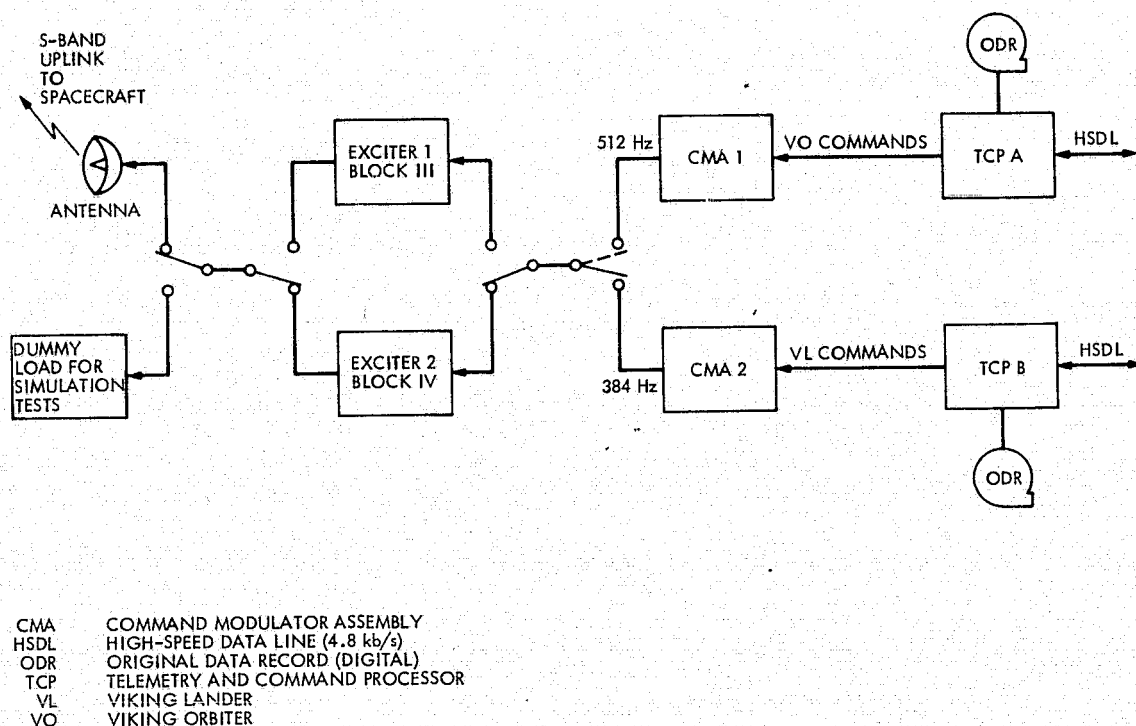
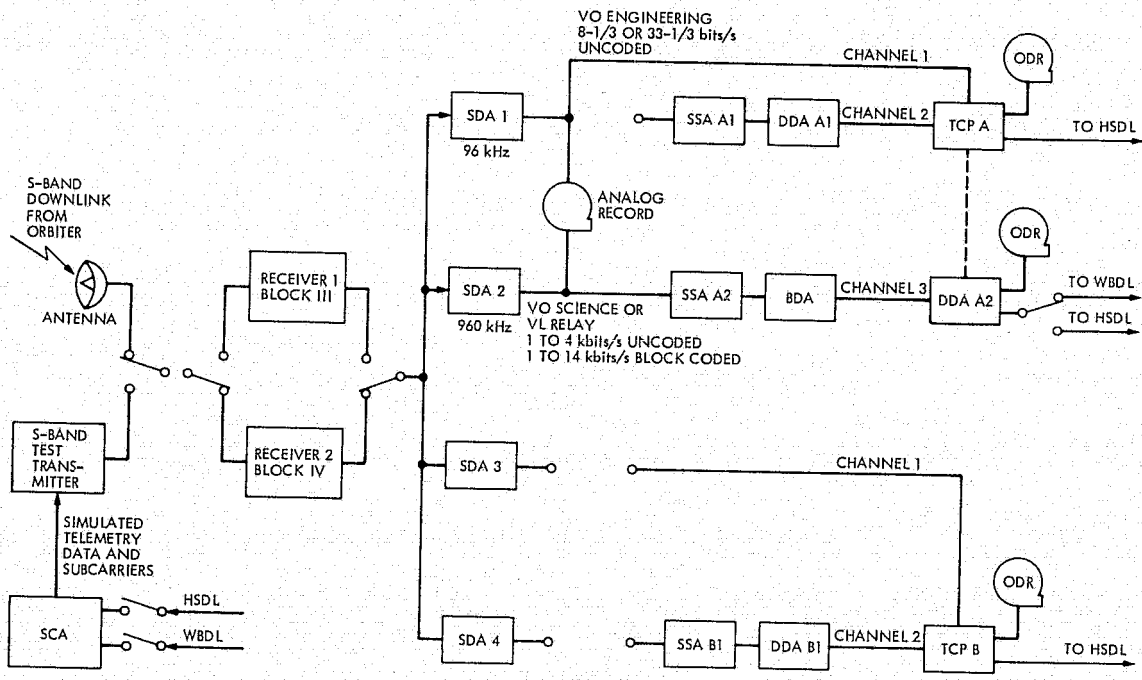

Fig. 47. Merritt Island Station MIL-71 command configuration for Viking Orbiter and Lander Tests

The Simulation Conversion Assembly of the Station Test and Training Subsystem was operated in the computer-remote ("long-loop") mode to support telemetry simulation for the System Integration and Ground Data System Tests, and was operated in the computer-local ("stand-alone") mode for pretest telemetry data transfer verification in each of the remaining tests. During these tests, there were no failures in the Simulation Conversion Assembly. A couple of malfunctions occurred in the Command Subsystem, and several failures were encountered in the Telemetry Subsystem.

Test results gave assurance that the Station, Control Center, and Communications were effectively used as elements of the Ground Data System for premission engineering tests and flight team preliminary training. However, the successful support of the tests required extensive use of redundant equipments, particularly those in the telemetry subsystem.

The most persistent problems encountered during the Data System Compatibility Test were related to low reliability of Data Decoder Assemblies and the Block Decoder Assembly hardware. Command Subsystem performance and Simulation Conversion Assembly performance were very satisfactory. Ground communications performance was also quite satisfactory. The Network Data Processing functions provided useful,



*THE DDA ON CHANNEL 3 IS USED FOR OUTPUT FORMATTING

BDA	BLOCK DECODER ASSEMBLY	SCA	SIMULATION CONVERSION ASSEMBLY	VL	VIKING LANDER
DDA	DATA DECODER ASSEMBLY*	SDA	SUBCARRIER DEMODULATOR ASSEMBLY	VO	VIKING ORBITER
HSDL	HIGH-SPEED DATA LINE	SSA	SYMBOL SYNCHRONIZER ASSEMBLY	WBDL	WIDEBAND DATA LINE
ODR	ORIGINAL DATA RECORD	TCP	TELEMETRY AND COMMAND PROCESSOR		(28.5 kbits/s)

Fig. 48. Merritt Island Station MIL-71 telemetry configuration for Viking Orbiter and Lander Capsule mated spacecraft tests

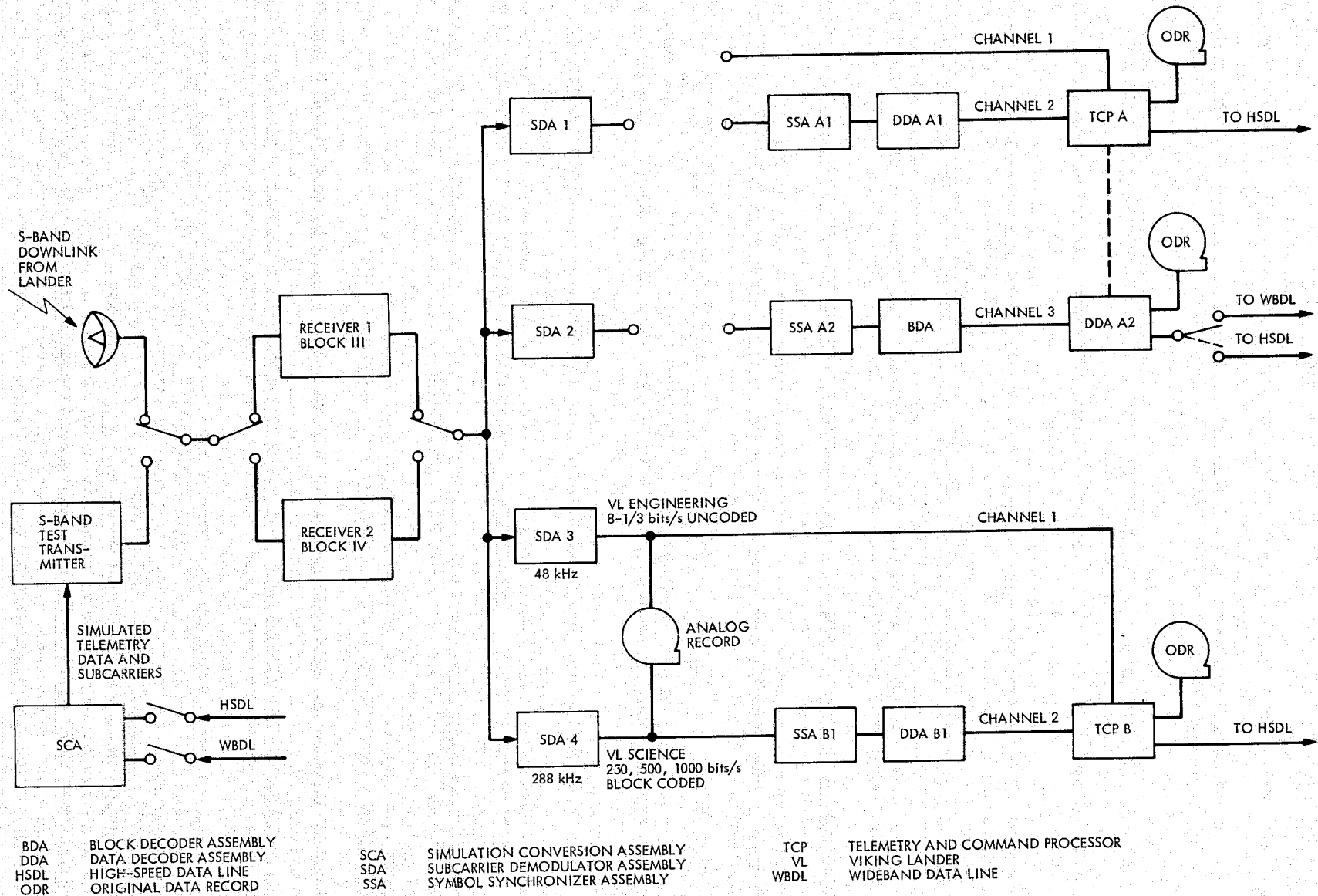

Fig. 49. Merritt Island Station MIL-71 telemetry configuration for Viking Lander tests

independent Network validation of command and telemetry status, within the constraints of the present implementation. No software problems in the Station subsystems nor in the Network Data Processing Area appeared during the testing.

2. System Integration and Ground Data System Testing

The System Integration Tests for the Station to Mission Control Center interfaces simulated Orbiter, Lander, and Spacecraft command operations and processing of dual-subcarrier telemetry data using the configurations shown in Figs. 47 and 48.

Test activities were scheduled over two days (January 9 and February 18). Discrepancies found the first day included a timing problem in the Data Decoder Assembly that introduced frequency errors in the Lander 500-bps and 1-kbps block-coded telemetry data, and errors in the Orbiter 16-kbps block-coded telemetry data caused by the Block Decoder Assembly on Channel 3 of the Telemetry and Command Processor A. No discrepancies were found February 18.

Subsequent to the January 9 testing, intensive troubleshooting and testing at the Station prepared the station for the Lander telecommunications radio-frequency compatibility testing of January 30 through February 7. Prior to February 18, two engineering verification tests were conducted with Network Operations Control Center Support.

Conducted March 11 and 18, Ground Data System test No. 7.0 sequence was equivalent to the System Integration Test sequence as far as the Network was concerned. However, the test involved more output and display processing for the Mission Control Center. Yet, despite several equipment malfunctions at the Station on March 11, more than half of the tests objectives were completed through use of backup capability. Problems and solutions included:

- (1) With failure of the tape unit on Telemetry and Command Processor A, medium rate data were paralleled through the B Processor to obtain a good Digital Original Data Record.
- (2) When Subcarrier Demodulator Assembly No. 1 would not lock up on data from the receiver, the second unit was used to the end of the tests.
- (3) Data Decoder Assembly A1, which was assigned to Telemetry and Command Processor Channel 3 for the test, put the wrong time in the wideband data blocks; not impacting the real-time processing of high-rate data, it did cause impact on 9-track Original Data Record playback.

- (4) When Command Modulator Assembly No. 2 gave alarms that would not clear with reinitialization, the Lander-direct command operation was transferred to Command Modulator Processor A, Assembly No. 1.

The Ground Data System Test was successfully completed on March 18. On that date, the only Network anomaly encountered was a 10-minute data outage that occurred when a symbol synchronizer assembly and the Block Decoder Assembly did not acquire lock when the data rate was changed from 16 kbps to 2 kbps. A reinitialization of Telemetry and Command Processor Channel 3 cleared the problem.

3. Mission Precursor Testing

a. Objectives. An Orbiter precount and Lander Capsule pre-launch checkout was performed during the precursor launch pad operations with spacecraft A. This activity was designed to verify operations with the spacecraft from launch minus 6 days (L - 6 days) to launch. The secondary objective was to involve the Flight Operations System (launch and cruise configuration) in these tests to determine the capability to receive and analyze data to determine launch readiness. Additionally it was used to actively verify command compatibility and final prelaunch update compatibility to the lander via the orbiter and to the orbiter.

b. Results. The Mission Precursor Tests were conducted with the mated spacecraft mounted on the launch vehicle with S-band telecommunications from the Orbiter. During the Flight Events Demonstration on April 1, the Merritt Island Station received low- and high-rate telemetry on the Orbiter link and also processed low-rate telemetry received from nearby near-Earth stations. No commanding was required, and no problems were experienced. On April 2, the Station again experienced no problems during an Orbiter precount test. The test involved remote commanding as well as telemetry processing over the full range of data rates.

The prelaunch checkout precursor was conducted on April 3 with the test sequence including Orbiter commanding and Lander-capsule commanding through the Orbiter. Telemetry included both Orbiter and Lander data on the Orbiter subcarriers. At the start of the test, Command Modulator Assembly No. 2 was not ready to be turned over to the Project. The Command System Cognizant Operations Engineer at Jet Propulsion Laboratory isolated the problem and instituted a temporary fix. During this test, the Data Decoder Assembly started putting the wrong time in the wideband data blocks output on channel 3 of the Telemetry and Command Processor. After trying a front panel reload, and replacing the Frequency and Timing Subsystem drawer without correcting the problem, Data Decoder Assembly No. 2 was assigned to Channel 3 of the Telemetry and Command Processor.

The Terminal Countdown Demonstration was conducted on April 5, with the test sequence essentially that of the Flight Events Demonstration Test. Merritt Island Station's function was receiving and processing telemetry from the spacecraft and nearby near-Earth stations. The test was completed successfully despite another Data Decoder timing problem and a large number of data block error bursts in the NASA Communications Network line.

4. Flight-Article Compatibility Tests

a. Objectives. The Flight-Article Compatibility testing was designed to verify that the flight configuration of the Flight Operations System was compatible with the flight spacecraft. Tests 3 and 4 were performed at Kennedy Space Center with Lander Capsule 1 and Orbiter 1. Test 1A and 1B were performed at the same space center with Lander Capsule 2. The communication link between the Test Facility and the Viking Mission Support Areas at Viking Mission Control and Computing Center were via the Merritt Island Station. Test No. 2 was conducted in Pasadena with Orbiter 2 and communications via Compatibility Test Area 21 to the Viking compatibility test area at the Viking Control Center.

b. Description and Results. Test No. 2 was designed to demonstrate that the Flight Article (Orbiter 2) was compatible with the state of the Flight Operations System Ground Data System, which was to be used for the 1975 launch. The Orbiter was placed in typical mission modes, rates, and formats with the telemetry link configured for the predicted nominal level. The Orbiter was initialized by system test equipment to the state required to begin the test and the data transmitted to Mission Control Center for processing with the mission operations software. The test was conducted at Compatibility Test Area 21 on January 20 while Orbiter 2 was still in the Spacecraft Assembly Facility prior to shipment to Kennedy Space Center. This test was supported satisfactorily by the test facility, Ground Communications Facility, and the Network Control Center, with the Viking Compatibility Test Manager as supervisor and with participation by the Viking Flight Team.

On April 10, Test No. 3 proved the compatibility of data to and from the Flight Spacecraft (mated Orbiter 1 and Lander 1) and the Ground Data System. Specifically, Lander pre-separation and Format 1 data were passed across the Lander/Orbiter hardline interface and telemetered on the Orbiter downlink. It was demonstrated that the Flight Lander was capable of receiving and processing commands through the Flight Orbiter from the Ground Data System. The Merritt Island Station transmitted the commands to the Lander both remotely from the Mission Support Area and locally with mylar tapes. The Flight Orbiter demonstrated playback capability of Orbiter data at selected rates while in the mated configuration. Specified downlink states were processed while the telemetry link was configured for the predicted nominal level. This provided data points for any degradation in the overall end-to-end data processing system. After spacecraft trouble delayed

the test 3-1/2 hours, the Station overcame Block Decoder Assembly problems by switching to backup equipment. Command and telemetry stream processing was not impaired despite the telemetry time tags being in error for a short while. Recall of Original Data Record was not required at the end of the test.

In Test No. 4, the Lander transmitted real-time and stored science and engineering data in selected formats to the Orbiter via the relay transmitter at 4 and 16 kbps. The Orbiter recorded the data on Track 8 of one of the Digital Tape Recorders, and either relayed the 4-kbps Lander data directly on the Orbiter High-Rate Channel at 4 kbps, or played back the Digital Tape Recorder Track 8 later at each of the High-Rate Channel data rates, 1, 2, 4, 8, or 16 kbps. The multimission Ground Command System or the Orbiter computer was used to command data modes and rates on the Orbiter, and the Lander was controlled by Systems Test Equipment or the Guidance Control and Sequencing Computer.

Specified downlink states were processed with the telemetry configured for the predicted nominal level. This provided data points for any degradation in the overall end-to-end data processing system.

The Lander/Orbiter was initialized by the ground system test equipment to the state required to begin the test. This was accomplished by direct test equipment to Lander and Orbiter communication links and the Mission Control Center and Merritt Island Station.

Test No. 4 was conducted on April 15 with the test sequence representing the command and telemetry activities related to the Lander capsule separation, descent, entry, and Mars landing events of the mission. The very high frequency link from the Lander capsule to the Orbiter was by cable. Spacecraft anomalies encountered during the test extended the time required to complete the test. There were no equipment malfunctions and only one procedural problem.

Test No. 1 was to be a telemetry and command test involving the Mission Control Center, the Merritt Island Station, and the Lander Capsule 1. Test No. 1 was divided into two sequences. Part 1 established the Direct Communication System uplink/downlink. Part 2 was representative of a typical landed science sequence and Direct Communication System transmissions. The updates contained in Part 1 were verified by Memory Readout prior to execution in Part 2. Commanding was accomplished from the Mission Support Area, which was also used for monitoring Lander Capsule 1 telemetry data.

Specified downlink states were processed with the telemetry link configured for the predicted nominal signal level. This provided data points for any degradation in the overall end-to-end data processing system.

On April 17, Test No. 1 was conducted with the test sequence representing a set of Lander activities on the Martian surface with direct S-band telecommunications. Because of input/output control problems in Telemetry and Command Processor A, the Merritt Island Station was configured to use B string as the prime string at "test start" time. However, when the A string was reloaded and verified, the unit was declared prime and used through the remainder of the test. The B string was kept in a hot backup mode. Data Decoder A1 had a bad timing error problem and was not used. In the final hour of the test, when the downlink was acquired in the Network Control Center, the high-rate telemetry data was good, but, the low-rate telemetry (8-1/3-bps) output was poor because of fluctuations of the signal-to-noise ratio. Therefore, the low-rate telemetry from the B string was added to the high-speed data line and validated in the Network Operations Control Center. After completion of the test, a test of the string A low-rate channel determined that a simple, two type-in, reinitialization of the channel eliminated the signal-to-noise ratio fluctuations. Support of command activity was satisfactory throughout the test as it was in most of the previous tests.

5. Communications and Operations Control Center Support

The satisfactory operation of voice, high-speed data, and wide-band data circuits provided by the NASA Communications Network and the JPL Ground Communications Facility was vital to the success of these tests. Within the implementation constraints, the Network Operations Control Center performed admirably throughout the tests, relying on the Block II System configuration to provide real-time displays of telemetry data and command system data received via high-speed data line. The Block II System implementation does not provide any real-time displays of telemetry data received via wideband data line; therefore, the only visibility of wideband telemetry was by Block I line printer dumps of data blocks, which was an awkward and time-consuming method to validate telemetry system status. (Block III Network Control System implementation provides real-time wideband telemetry displays.) Also, there were no station monitor data available in the Network Operations Control Center nor at the Merritt Island Station because the Station does not have a monitor subsystem.

6. Orbiter, Lander, Spacecraft Radio-Frequency Compatibility Testing

The series of tests that verified telecommunications design compatibility between the Merritt Island Station and the Viking Landers, Orbiters, and Spacecraft at the Kennedy Space Center, Florida, began in January 1975 with Viking Lander 1. Support cooperation between the launch operations teams, spacecraft teams and the

Station technical staff was excellent and most objectives were met. (Design compatibility had been previously established between the Deep Space Network and the spacecraft radio modules at Compatibility Test Area 21.

Ground station software used in performing these tests was a subset of software officially released to the station for Viking Project support. The software consisted of the Telemetry and Command program, which provided independent control of the commanding and telemetry functions. Commands could be controlled manually from the station or automatically from the Mission Control Center. Telemetry could be decoded, formatted, and transmitted to the Mission Control Center for decommutation and display.

a. Viking Lander 1. From January 30 through February 7, 65 hours of test time were expended in verifying Lander 1 direct communications links. Tests were performed for verifying transponder, radio-frequency, command, telemetry, and radio metric compatibility, as well as verification of synchronization under varying data patterns. Radio-frequency link amplitude variations were a maximum of 1.0 dB peak-to-peak as established from link stability tests conducted prior to the initialization of the compatibility test program. Fig. 50 shows the test configuration.

Criteria established for radio-frequency acquisition, command performance, metric data, telemetry performance with and without doppler, and Network Operations Control Center telemetry verification were met. The 8.33-bps engineering data and the 250-bps block coded data were received by the Control Center and verified as good.

b. Viking Orbiter 1. These compatibility tests were conducted from February 27 to March 1; in all, 24 hours of test time were expended in verifying Orbiter 1. Although all tests specified were not completed and the air link signal variations during many of the tests exceeded the expected variations, sufficient tests were completed to verify that no incompatibility existed between the Network and Orbiter 1. The test criteria and parameters simulated direct communications between an Orbiter flight article in Mars orbit and a 64-meter antenna station. A selected set of standard tests, as specified, was performed for verifying transponder, radio-frequency, command, telemetry and radio metric compatibility. An S-band, two-way radio frequency air link, and an X-band, one-way radio-frequency air downlink were used between the flight article and the ground station. Each radio-frequency air link was approximately seven miles long. The test configuration is shown in Fig. 50.

The Telemetry and Command Program provided independent control of the commanding and telemetry handling functions. Commands could be controlled manually from the station or automatically from the Mission

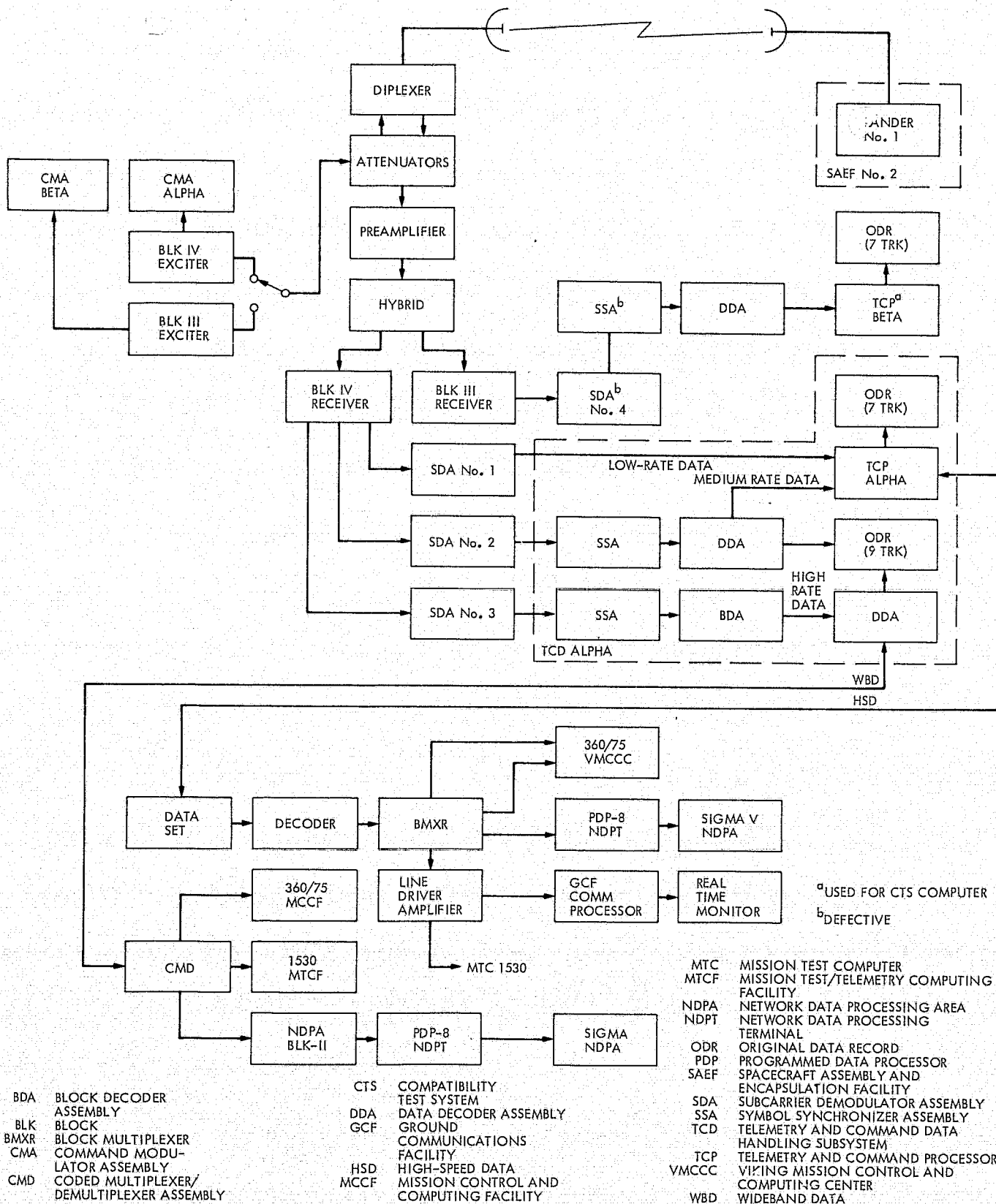

Fig. 50. Telecommunications compatibility test configuration, January 30, 1975

Control and Computing Center, and telemetry could be decoded, formatted and transmitted to the same Control Center for decommutation and display.

The Planetary Ranging Assembly Program provided either continuous spectrum or discrete spectrum operation for determining very accurate range estimates of a spacecraft at planetary distances.

The following radio-frequency acquisition and tracking tests were conducted:

- (1) Downlink threshold one-way.
- (2) Uplink threshold.
- (3) Downlink threshold two-way.
- (4) Spacecraft receiver pull-in range and rate.
- (5) Carrier residual phase jitter.
- (6) Transponder rest frequency.
- (7) Auxiliary oscillator frequency.

Telemetry tests performed were:

- (1) Downlink Spectrum Analysis.
- (2) Modulation Index.
- (3) Spectrum Analysis.
- (4) Telemetry Performance Test.

In most instances where criteria were not met, the causes were procedural errors.

On March 3, a posttest calibration of the radio frequency link (S-band and X-band) was performed. A three-hour S-band differenced range vs integrated doppler stability run was performed using the Planetary Ranging Assembly software to establish initial ranging acquisition and estimate drift changes over 5-minute sample periods. A histogram of deviation vs number of samples is shown in Fig. 51. During the same time period, an S-band amplitude stability run was performed. Each printout showed the mean automatic gain control voltage, the one sigma standard deviation and the number of samples averaged over a 10-minute period. In similar fashion, a 2 hour and 10 minute X-band differenced range vs integrated doppler stability run was performed. The data associated with this test are shown in Fig. 52.

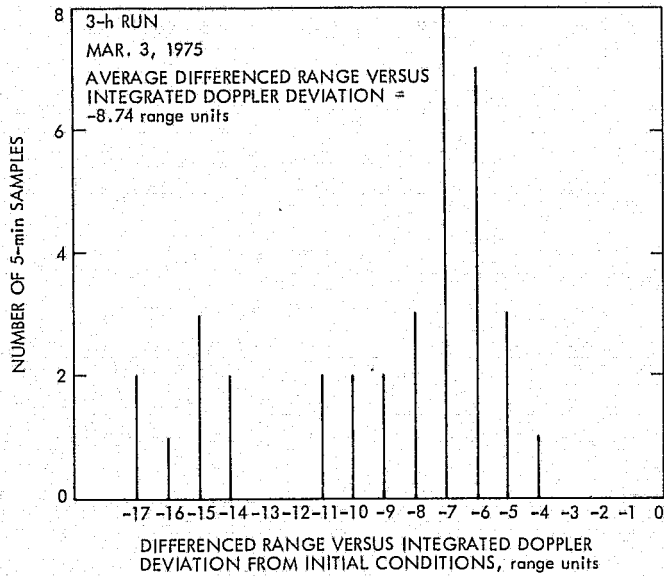

Fig. 51. Hangar A0/Merritt Island S-band Differenced Range Versus Integrated Doppler stability

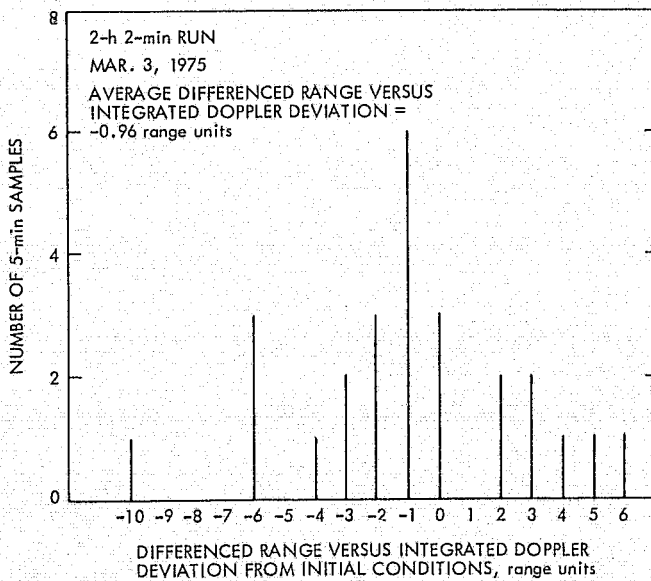

Fig. 52. Hangar A0/Merritt Island X-band Differenced Range Versus Integrated Doppler stability

c. Viking Spacecraft 1. This 6-hour compatibility test was conducted at the Kennedy Space Center, on March 22. Objectives of the test were to verify in the full spacecraft configuration the capability of Orbiter 1 to receive Orbiter commands and reject Lander Capsule commands, and to verify in the spacecraft configuration the capability of Lander 1 to receive Lander Capsule commands and reject Orbiter commands. An S-band radio frequency air link of approximately three miles was used between the flight article and the ground station. The test configuration is shown in Fig. 50.

Command tests were performed to verify Orbiter/Lander command discrimination in both command detectors.

d. Viking Lander 2. These tests were performed from April 7 through 9 for 24 hours. Test objectives were to verify telecommunications design compatibility between the Deep Space Network and the flight Lander 2. The test criteria and parameters simulated direct communications between a lander flight article on Mars and a 64-meter antenna Deep Space Station. A selected set of standard tests was performed for verifying transponder, radio-frequency, command, telemetry and radio metric compatibility.

An S-band radio-frequency air link of approximately three miles was used between the flight article and the ground station. Radio-frequency link amplitude variations were a maximum of 1.0 dB peak-to-peak during the tests as established from link stability tests conducted prior to the initialization of the compatibility test program. The test configuration is shown in Fig. 50.

Radio frequency tests performed were:

- (1) Carrier acquisition and threshold.
- (2) Downlink one-way.
- (3) Uplink one-way.
- (4) Downlink two-way.
- (5) Spacecraft receiver acquisition.
- (6) Pull-in range.
- (7) Tracking range and rate.
- (8) Downlink phase jitter.
- (9) Residual carrier phase jitter.
- (10) Residual subcarrier phase jitter.

- (11) Radio-frequency downlink spectrum analysis.
- (12) Transponder rest frequency (voltage-controlled oscillator).
- (13) Auxiliary oscillator frequency.

The test criteria for these tests were met. For those tests without criteria, the data were obtained for information. No significant problems were encountered or identified.

Metric data tests performed were:

- (1) Ranging polarity verification.
- (2) Ranging acquisition threshold.
- (3) Ranging delay verification.

The polarity of the transmitted ranging signal was verified at strong uplink and downlink signal levels. No significant problems were encountered or identified as the criteria for ranging delay measurements were met.

A telemetry test was performed of telemetry performance with and without doppler. The criteria for this test were met without significant problems being encountered or identified.

e. Final Radio-Frequency Compatibility Tests. Tests were run between the Merritt Island Station and Orbiter 1 at Cape Canaveral on May 27-29, and then with Viking 2 (Orbiter and Lander combined) on July 7. The latter, marked the successful completion of formal radio-frequency telecommunications testing between the Deep Space Network and the Viking Project for the 1975 mission.

For Orbiter 1, the final procedures and test plans were approved during a meeting of the Deep Space Network/Viking Orbiter Telecommunications Representatives at Cape Canaveral. The total test time was 28 hours. All tests given in Ref. 11 were completed although specified performance criteria for auxiliary oscillator No. 2 and low-rate telemetry were not actually met. The extent of completion of tests achieved within the scheduled time period was due in large measure to the excellent support provided by the Jet Propulsion Laboratory/Spacecraft Tracking and Data Network (Merritt Island) and spacecraft teams. The objective of the tests was to verify telecommunications compatibility between the Deep Space Network and Orbiter. The test criteria and parameters simulated direct communications between an orbiter flight article in Mars orbit and a 64-meter Deep Space Station.

REPRODUCIBILITY OF THE
ORIGINAL PAGE IS POOR

Orbiter 1 was located in the clean room of Building A0 at the Air Force Eastern Test Range, and configured for mission operations. An S-band two-way radio frequency link and an X-band one-way radio frequency downlink were utilized between Orbiter 1 and the Merritt Island Station.

S-band radio frequency link variations were 0.5 dB peak-to-peak during the test. These conditions existed during daylight and evening hours on May 28 and 29. X-band radio frequency link variations were 1.0 dB peak-to-peak during evening hours when critical X-band testing was being performed.

Radio frequency acquisition and tracking tests performed were:

- (1) Downlink threshold one-way.
- (2) Uplink threshold.
- (3) Downlink threshold two-way.
- (4) Spacecraft receiver pull-in range and rate.
- (5) Carrier residual phase jitter.
- (6) Transponder rest frequency.
- (7) Auxiliary oscillator frequency.

Problems were not encountered during a test of command capability under doppler conditions and none were encountered in radio metric data tests.

All objectives of the radio metric tests were met, including simultaneous S/X ranging, which was accomplished for the first time between the Network and a flight spacecraft. Simultaneous delay measurements were within 3 ns of previously measured individual delay measurements. S-band link amplitude stability performance during this test was 1 dB peak-to-peak, and X-band was 2 dB peak-to-peak. Telemetry tests performed were modulation index and spectrum analysis, and telemetry performance test.

The Viking Spacecraft tests were successfully completed within the scheduled time period of 11 hours. The objectives of the compatibility tests were to verify, in the spacecraft configuration, the capability of (1) Orbiter 2 to receive Viking Orbiter commands and reject Viking Lander Capsule commands, and (2) Lander 2 to receive Viking Lander Capsule commands and reject Viking Orbiter commands. Command tests performed were (1) Orbiter/Lander Command Discrimination Test (Side 1), and (2) Orbiter/Lander Command Discrimination Test (Side 2).

f. Conclusion. The successful completion of the Deep Space Network/Viking Project Telecommunications Compatibility Test Program established telecommunications compatibility as evidenced by the successful launch of the Viking spacecraft on August 21 and September 9, 1975.

The importance of a formal compatibility test program was clearly demonstrated by the problem areas uncovered, verified, and resolved during the testing. Prominent problem areas resolved during the test program were:

- (1) Verification of Network capability to receive simultaneous multiple downlinks, and to process and transmit data to the Mission Control and Computing Center.
- (2) Verification of false uplink acquisition by the Viking Orbiter and Lander with S-band radio frequency channels 13 and 20 modulated with command and ranging.
- (3) Ranging modulation polarity inversion by the Block IV exciter.
- (4) Inverted pulse polarity of the Frequency and Timing Subsystem 1-k pulse per second to the Telemetry and Command Processor, which resulted in command symbol period alarm/aborts.
- (5) The Orbiter 1 radio frequency subsystem auxiliary oscillator No. 2 was found to be 800 Hz below design center frequency.
- (6) A transitory increase in spacecraft receiver automatic gain control when discrete ranging modulation is turned on and during a ranging acquisition sequence.
- (7) Viking Orbiter 2 automatic gain control remaining positive during a sweep acquisition until the uplink frequency ramp function is terminated.

These and other problems, undetected and unresolved prior to launch, would have presented serious operational problems to the Deep Space Network and Viking Project during the mission.

E. NETWORK TESTING

1. Concepts of Network Testing

The concept of Network testing at the Network level is based on the three phases of network activity shown in Fig. 53. As the facility implementation is completed, System Performance Tests are conducted to verify that system requirements have been satisfied. These tests are specified and carried out by the Network System Engineers.

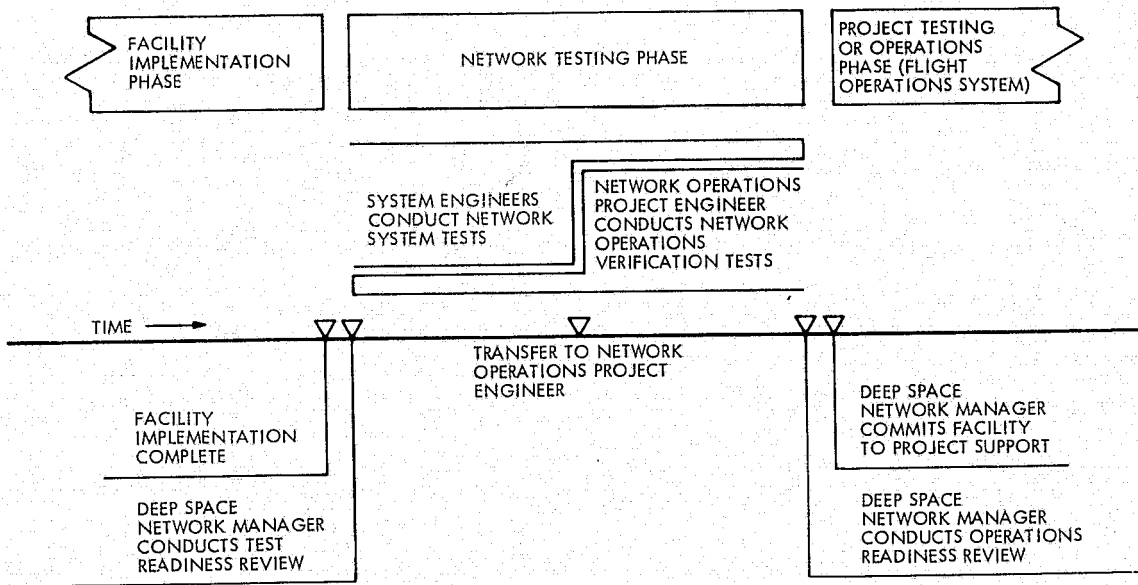

Fig. 53. Three phases of Network activity

Following this phase, the Network Operations Project Engineer carries out a family of tests using the particular mission configuration required by the Project. Finally, with the mission configuration verified, the station personnel carries out a set of operational tests to demonstrate their ability to operate the equipment in any of the configurations that might be called for in the actual flight operations.

This series of tests played a significant part in preparing the Deep Space Network for support of Viking, and, because they are frequently referred to throughout this report, are described more fully as follows.

a. System Performance Tests. The purpose of the Telemetry, Command, Monitor, or Tracking System Performance Tests is to demonstrate that each system meets the specified level of performance when tested simultaneously with operational software. The tests normally are conducted with hardware that has been transferred from the development to the operations organization and software that has been transferred to the Network Program Library. The test procedures make use of all elements of the Deep Space Station subsystems within a given station and provide a basis for Station system-level maintenance, performance verification, and prepass testing. The successful completion of a System Performance Test verified that the system meets documented specifications and qualifies it for Network-level support on a mission-independent basis.

The main prerequisites to running a System Performance Test are:

- (1) Implementation of Station/Ground Communications Facility and Network Operations Control Center.
- (2) Hardware and software transferred to Operations.
- (3) Facility mission-independent training complete.

The tests are conducted by the Cognizant Operations Engineer for the particular System under evaluation.

b. Mission Configuration Tests. The purpose of the Telemetry, Command, Monitor, or Tracking Mission Configuration Tests is to demonstrate that the Network system(s) meets the specified level of performance when tested singly or simultaneously in the Viking configurations specified in the Network Operations Plan. The tests utilize software and hardware that have been transferred to Operations and are run with all elements of the Network, Stations, Ground Communications, and Control Center. Test procedures provide the basis for system-level maintenance, performance verification, and prepass testing. Successful completion of the tests verifies the Network's capability to support the flight Project.

Before Mission Configuration Tests are run, the Network must be in the correct flight project configuration and the System Performance Tests must have been completed.

Mission Configuration Tests are supported by Station, Ground Communications, and Network Control Center personnel as required and conducted by the Subsystem Cognizant Engineer at the direction of the Network Operations Project Engineer or his designate.

c. Deep Space Network/Viking Mission Control and Computing Center System Integration Tests. These tests verify the interface between elements of the Deep Space Network and the Viking Mission Control and Computing Center. All data flow interfaces are verified at data rates expected during mission operations. These data also verify hardware interfaces in a multiple-mission environment.

Successful completion of the Network Performance and Configuration Tests and some Operational Verification Tests are prerequisites to the System Integration Tests. However, while Operational test completion is desirable, it is not mandatory as operational procedures are not necessarily followed during these tests.

The Viking System Integration Tests were run under the direction of the following personnel:

- (1) Test Supervisor: Mission Control Center Facility Engineer.
- (2) Test Conductor: Mission Control Center Integration Test Supervisor.
- (3) DSN Test Support: Viking Network Operations Project Engineer, System Cognizant Operations Engineer, and Network Operations Analysts, plus station, communications, and Network Operations Control Center personnel as required.
- (4) Performance Evaluation: Viking Ground Data System Engineer.

d. Operational Verification Tests. The purpose of these tests is to verify the operational readiness of the Network to support the Project Test and Training and Operational Phases. They demonstrate the operational proficiency of Network personnel in the use of operating procedures, interfaces, and equipment. They demonstrate that Network personnel are adequately trained and, in addition, provide valuable training. Operational Tests follow a time-compressed sequence of events designed to exercise all Network operational procedures and confirm the ability of the stations to send manual commands and carry out telemetry bit rate changes in the time specified.

The first tests with any facility are considered to be a phase of training coupled with performance demonstration. The training aspect diminishes progressively as the tests proceed. Since all Station, Ground Communication Facility, and Network Operations Control operational shifts of personnel must be adequately exercised, the Viking Operations Project Engineer must initiate extra tests at specified times.

Satisfactory completion of Software Acceptance Tests for all systems, System Performance Tests for all systems, and Mission Configurations Tests are the requisite to running Operational Verification Tests at any deep space station.

2. Network Test Schedule Changes

Although the 26-meter stations required relatively minor hardware additions for Viking, the 64-meter stations required extensive equipment installations. The overseas 64-meter stations (43 and 63) were not scheduled to be fully implemented for Viking until after launch. Station 14, however, was scheduled to be fully implemented to support the Project prelaunch planetary tests in January 1975.

The implementation-complete milestone for Station 14 was originally scheduled for September 15, 1974. It first moved to mid-October, then mid-November, early December, and finally to January 4, 1975, a total slip of 3-1/2 months.

The generation of procedures for Network System Performance Tests and Mission Configuration Tests, and actual test accomplishment, had originally been scheduled to take place between September 15 and mid-November; time was also scheduled during this period for on-site mission-independent training and mission-dependent training. Then followed a six-week period to January 1, 1975, during which time the station "freeze" for Network support of Pioneer 11 Jupiter encounter precluded accomplishment of Performance or Configuration Tests at the Mars Station (16). Station Operational Verification Tests were to commence in mid-November and be completed on March 1, 1975, overlapping with Network/Mission Control Center System Integration Tests during February 1975.

Because of the lack of hardware, the on-site mission independent and mission dependent activities were moved to January and the multi-mission Performance Tests had to be cancelled. The mission-dependent Configuration Tests, which provide for adequate testing of the Network systems to Viking specifications, started on December 21, 1974. The Operational Verification Tests were then compressed and rescheduled to start the first week in February 1975; the length of each test and number of tests were reduced, but more tests per week had to be scheduled.

3. Mission Configuration Tests

For the Mission Configuration Tests, software and hardware that had been transferred to Operations were used and the tests were run with all elements of the Network, Stations, Ground Communications Facility, and Network Operations Control.

Mission Configuration Tests conducted in the periods from December 21, 1974, to January 5, 1975, consisted solely of isolating and rectifying hardware failures and interface problems mostly related to the newly implemented Viking telemetry and command configurations. No meaningful test results were obtained, but numerous necessary minor modifications to the hardware and streamlining of test procedures were accomplished.

A test on January 8, 1975, resulted in data passing successfully through the three telemetry channels of Telemetry and Command Data Subsystem 1. Subsequent tests through February 3, 1975, resulted in completion of all telemetry strong signal tests and completion of Command System tests on the alpha Block III Receiver/Exciter Subsystem string.

The completion of these tests qualified Goldstone Station 14 to support the Network Operational Verification Tests and Network/Mission Control Center System Integration Tests.

Final transfer of the Block IV Receiver/Exciter and some associated equipment from engineering to operations was required to permit completion of weak signal telemetry system tests and the remainder of the Command and Tracking System Tests prior to the Viking Project Ground Data System tests and Planetary Verification Tests. The extra time required for this testing, which was necessitated by the equipment failures and debugging activities, was obtained by reducing Pioneer, Mariner, and Helios tracking coverage.

Figures 54 and 55 represent the status of the 64-meter and primary Viking 26-meter subnets, showing the planned vs actual status as of mid-April. The initial blocks of time, as previously stated, represent the strong signal tests preparatory to start of Operational Verification Tests, System Integration Tests, and Ground Data System Tests. The second time blocks represent the low-signal telemetry bit error and doppler jitter tests, which do not affect the station configuration and are carried out on a noninterference basis for completion prior to launch.

Summarizing the test status, all the stations were on or ahead of schedule and there was a high degree of confidence that all remaining tests would be completed prior to launch as scheduled.

However, a significant change from earlier planning was brought about by the decision to implement the second 26-meter subnet (Deep

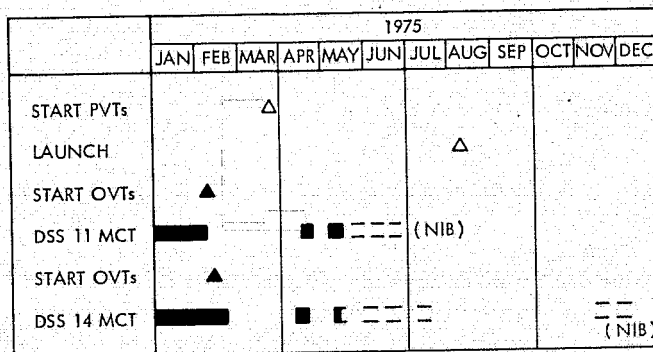

DSS DEEP SPACE STATION
MCT MISSION CONFIGURATION TEST
NIB NONINTERFERENCE BASIS
OVT OPERATIONAL VERIFICATION TEST
PVT PLANETARY VERIFICATION TEST

Fig. 54. Mission Configuration Test status for Stations 11 and 14 as of May 15, 1975

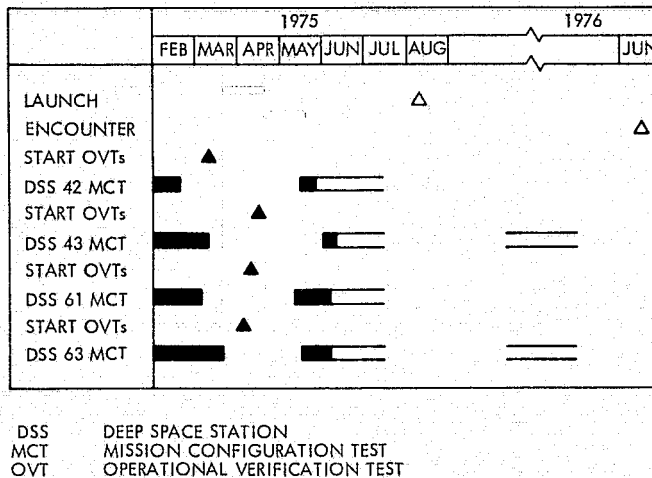

Fig. 55. Mission Configuration Test status for Stations 42, 43, 61, and 63 as of May 15, 1975

Space Stations 12, 44, 62) prior to the first Viking launch, but by the end of June the majority of the Mission configuration tests for these stations had been performed, and the operational verification tests had just been completed.

Table 10 shows the mission configuration test status of the 64-meter, primary 26-meter, and secondary 26-meter subnets, indicating actual testing status as of July 1, 1975.

4. Operational Verification Tests

Operational readiness of the Network to support the Project Test and Training and Operational Phases was verified by Operational Verification Tests. These tests demonstrated the proficiency of Network personnel in the use of operational procedures, interfaces, and equipment. They also demonstrated that Network personnel were adequately trained and, in addition, provided valuable training. Operational Verification Tests followed a time-compressed sequence of events designed to exercise all Network operational procedures and confirm the ability of the stations to send manual commands and carry out telemetry bit rate changes in the time specified.

Deep Space Stations 11, 14, 42, 43, 61, and 63 completed Operational Verification Tests between February 5 and April 17, 1975, and appeared qualified to support the Viking Mission. The planned schedule was for the stations to support System Integration Tests after each station shift had participated in at least one Operational Test. These tests were to be completed with all shifts prior to support of the first Ground Data System Test at that station. However, these criteria could not be met at Goldstone Station 14. A

Table 10. Status of Mission Configuration Tests as of July 1, 1975

Stations	DSS	Systems			
		Telemetry	Command	Tracking	Monitor and Control
64 m	14	Cruise/planetary	4 h outstanding (dual exciter switch)	Not complete	Cruise/planetary
	43	Cruise strong signal only	Cruise	Not complete	Cruise
	63	Cruise	Cruise	Not complete	Cruise
Prime 26 m	11	Cruise	Cruise	Not complete	Cruise/planetary
	42	Cruise	Cruise	Not complete	Cruise/planetary
	61	Cruise	Cruise	Not complete	Cruise/planetary
Secondary 26 m	12	Cruise	Cruise	Radio- frequency portion only	Cruise/planetary
	44	Cruise	Cruise	Radio- frequency portion only	Cruise/planetary
	62	Cruise	Cruise	Radio- frequency portion only	Cruise/planetary

recurring problem during the tests was with the Simulation Conversion Assembly, with much of this procedural failure a result of operator unfamiliarity with the Assembly.

Station 11 performed seven Operational Tests, only one of which was considered a failure. This failure occurred because data transfer delays were compounded by Simulation Conversion Assembly and Data Decoder Assembly hardware problems. The failures were isolated and rectified. Data Decoder Assembly hardware problems also occurred on two other tests. The one during Test No. 7 occurred on the Telemetry and Command Subsystem string, forcing a changeover to the backup. The transition and the repair of the Simulation Conversion Assembly during the test was considered excellent.

Seven tests also were performed at Station 14, with familiarity being gained with Viking planetary configuration and procedures. Two Data Decoder Assembly failures coupled with Simulation Conversion Assembly procedural problems on Test No. 2 used up 3-1/2 hours of test time. However, the knowledge gained resulted in the pretest calibration procedures for the 6-channel Simulation Conversion Assembly being generally overhauled. Again on Test No. 5, two decoders were down and a bad simulation tape was discovered. Yet, all objectives, except recalls, were met. On Test No. 4, only four telemetry channels could be used because Block Decoder No. 2 and Data Decoder Assembly No. 4 were faulty. Only Original Data Record recall could not be accomplished. Test No. 3 missed the playback portion because data transfer with the Simulation Conversion Assembly delayed the test start. All objectives were met on Test No. 7.

Problems during the six tests at Station 42 resulted from unfamiliarity with the Simulation Conversion Assembly, operator error during an Analog Original Data Record playback, delay caused by Simulation Conversion Assembly to Subcarrier Demodulation Assembly data routing, inability to locate frame synchronization of 8.333 bps, and the prime processor string being down. Test No. 6 was perfect and Australian Deep Space Station 42 was judged qualified for support.

The only test performed at Station 43 was partly successful because of delays created by problems with simulation on channels 5 and 6.

Procedural errors and an attempt at Data Original Data Record recall failed on Test No. 1 at Station 61 in Spain. Test Nos. 2 and 3 were completely successful.

All three tests at Station 63 were successful despite a slight core allocation problem in the Simulation Conversion Assembly core buffer during Test No. 1. A mated-Lander commanding was successfully performed on Test No. 3 as an added sequence of events item.

By July 1, 1975, the 64-meter and prime 26-meter subnets were considered trained to support Viking cruise operations. During the previous two months, Stations 43 and 63 had completed cruise phase operational verification tests. Station 14 and the prime and secondary 26-meter nets had completed cruise and planetary operational verification tests. The stations had also supported Viking System Integration Tests, ground data system tests and various others of the project-related test series including flight operations personnel test and training. No problems were anticipated on future support of the latter tests. Stations 43 and 63 would be supporting planetary phase operational verification tests after launch and prior to encounter. The Network Operations Control Team had achieved the desired level of Viking mission-dependent training proficiency required for Viking cruise support. The Mission Configuration Test program would be complete prior to launch.

Initial Acquisition Operational Tests had been scheduled for Stations 42 and 44 in Australia later in July to exercise the initial acquisition strategy produced by the Network and concurred by the Viking Project. These were the final tests to verify launch and cruise readiness.

Configuration control for Viking was applied to all stations on July 1, 1975.

F. FINAL PRELAUNCH OPERATIONS

1. Launch Readiness Reviews

The final stages of prelaunch operations began with the Deep Space Network-Viking Launch Readiness Review of July 9 and continued to the twice-delayed launch of Viking A on August 20. Another formal Launch Readiness Review was held July 22 and there was an update on August 6. At the time of the reviews, the scheduled launch date was August 11.

Requirements for Network launch and cruise support capability presented in the July reviews are shown in Table 11.

After the status reports at the July 9 review, the Deep Space Network was considered fully prepared to support both launch and cruise operations. The progress summary showed the completion of implementation of Viking launch and cruise configuration at all facilities with minor (no impact) exceptions, integration tests with the Viking Mission Control and Computing Center, operational tests and training at all stations except 42 and 44, the ground data program with Stations 12, 44, and 62 the only exceptions, and the radio frequency and Data Compatibility Tests with both spacecraft with no liens against them. Flexibility for network allocation was provided by the second 26-meter antenna station subnet. Negotiations had been set up for any conflicts between Viking and other Projects

Table 11. Launch and cruise capabilities considered in July reviews

26-meter subnet (Stations 11, 42, 61, 12, 44, 62)

Single uplink (command)

Single downlink (telemetry)

One low rate, plus one medium or high rate data stream

One high speed data channel

Digital Original Data Records with manual recall

S-band doppler

S-band ranging at DSSs 11, 42-43 (shared), and 61-63 (shared)

64-meter subnet (Stations 14, 43, 63)

Single uplink (command)

Single downlink (telemetry)

One low-rate, plus one medium- or high-rate data stream

One high-speed data channel

Digital Original Data Records with manual recall

S-band doppler

Planetary ranging in S- and X-band (Station 14)

Doppler on S- and X-band (Station 14)

One wideband data channel

Radio science very long baseline interferometry (Stations 14, 43)

S-band ranging at Stations 11, 42-43 (shared), and 61-63 (shared)

Ground communication

One high-speed (4800 bps) channel per 26-meter and 64-meter station

One wideband (50 kbps) channel to Station 14

One wideband (28.5 kbps) channel to Stations 43 and 63 in November 1975

Table 11 (contd)

Network Operations Control Center

Block III configuration for telemetry

Telemetry, command, tracking, monitor, and data validation

Manual recall from Digital Original Data Records

Predicts and Network sequence of events generation

Network Operations Control

for tracking support. The Engineering Change Order management system provided prompt visibility for potential areas of concern. Also, all significant Viking Incident, Surprise and Anomaly Report/Discrepancy Reports were closed with the balance to be cleared by July 22.

At the July 9 review, concern was expressed for anticipated complication of Viking cruise support with the Pioneer and Helios spacecraft support.

Figures 56 and 57 show the status of the Tracking and Data System Schedule and the Flight Operations Test Schedule as released with the July 9 review report.

By the second review in July, telecommunications compatibility had been established between the Network and both Viking Orbiters, Landers, and spacecraft; also all known problems and Network operational considerations were resolved and documented.

In summary, it was stated that Network launch capabilities were complete, additional cruise capabilities were on schedule, all configurations and interfaces had been tested, station crew training was complete, Network-Spacecraft compatibility was established, and configuration control was in effect.

2. Configuration Control, Freeze

To ensure that all the Network facilities maintained the "ready" state for the launch and cruise support, the facilities had been placed under configuration control on July 1. Under these conditions, the facilities could be returned to the Viking configuration in less than 12 hours from notification. Then, on July 22, modified configuration control was placed on all deep space stations. This meant that Engineering Change Orders could be initiated, for Viking planetary implementation as well as other projects, without prior concurrence by the

Viking Network Operations Project Engineer or the Network Manager. Configuration freeze was applied to initial acquisition stations in Australia on August 10 at the conclusion of a Configuration Verification test. This test concluded with the stations configured for the initial acquisition pass and automatically prohibited from supporting any other spacecraft tracks. The control and freeze activity is shown in a bar chart timeline form in Fig. 58.

3. Initial Acquisition Strategy

The initial acquisition strategy was jointly worked out by the Network, and Viking flight team members. Several safeguards had to be part of the initial acquisition configuration plans (1) to ensure

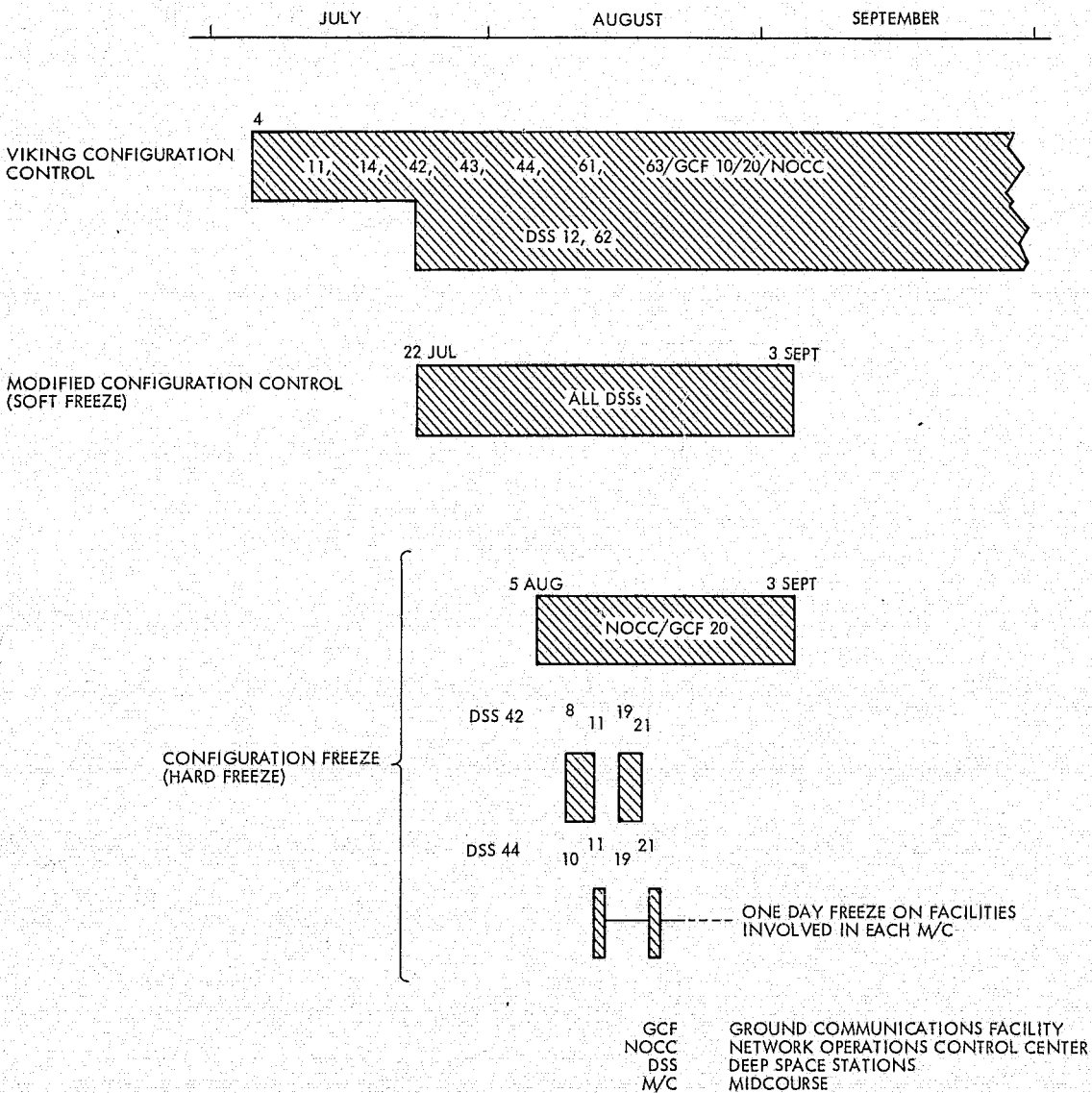

Fig. 58. Network configuration control for Viking

spacecraft acquisition by the ground transmitter signal, the S-band Acquisition Antenna had to be used, and, (2) to avoid receiver saturation, when receiving downlink on the S-band Cassegrain Monopulse Antenna, the Maser Bypass Mode was necessary. The Project desired to run a Canopus star map prior to Canopus star lock, a maneuver that required a 720-degree roll of the spacecraft. Because the attitude of the spacecraft was such that nulls greater than 40 dB were anticipated, the uplink transmitter was required on the high-gain scan antenna, necessitating a reconfiguration by the station from the acquisition antenna to the Cassegrain antenna.

It was agreed to by all concerned that the station reconfiguration should be done at L + 1 hour 36 minutes, but since telemetry was critical at that time, the reconfiguration had to be accomplished without loss of telemetry, which meant that Station 42 could not simply turn off its transmitter and reconfigure as this would result in loss of two-way lock resulting in loss of about one minute of telemetry data.

The plan worked out to accomplish the station up and downlink reconfiguration was to transfer the uplink to Station 44 while Station 42 reconfigured its transmitter and maser, then transfer the uplink back to Station 42. This unusual transfer permitted the reconfiguration and ensured that valuable bioshield telemetry data would be continuously received.

The initial acquisition, initial conditions at Stations 42 and 44, and the strategy are illustrated as a function of time in Fig. 59.

4. Network Testing and Training/Near Launch

The test and training effort was concluded on August 10 (one day before the scheduled launch of Viking A) with the successful completion of the Network Configuration Verification Test program.

By July 30 all committed deep space stations had successfully completed the system-level mission configuration and test program that started October 1, 1974. These tests included: Telemetry System strong and weak signal performance and simulation tests, as well as planetary phase testing at Goldstone Station 14; Command System tests; Monitor and Control System tests; System tests (radio metric data); and Simulation System tests.

The launch/cruise series of Operational Verification Tests also were completed with Stations 11, 12, and 14 at Goldstone; 42, 43, and 44 in Australia; and 61, 62, and 63 in Spain. The personnel manning the stations, the Ground Communications, and the Network Operations Control Center were considered fully trained to support the launch and cruise phases of the Viking mission.

Then effort was directed toward the training of personnel at the prime and backup stations in Australia for the initial acquisition of the Viking spacecraft downlink signal and subsequent establishment of

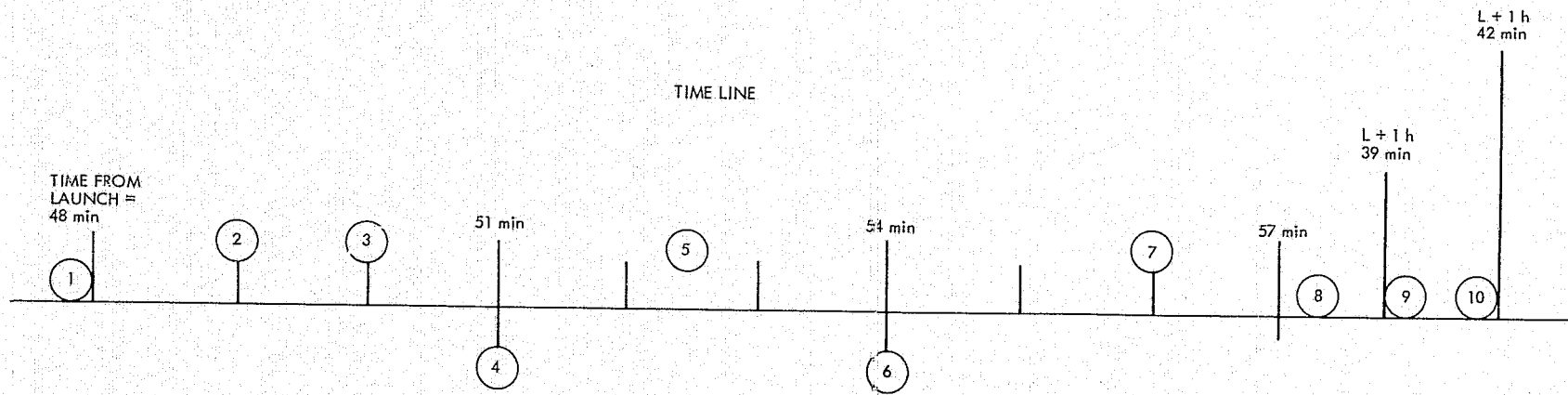

- 1 STATION 42 RECEIVER 6 ONE-WAY TELEMETRY TO LINE 1/5
STATION 44 RECEIVER 2 ONE-WAY TELEMETRY TO LINE 1/10 s
- 2 STATION 42 SIDE BAND SEARCH STATION 42 RECEIVER 5/STATION 44 RECEIVER 1
- 3 CONFIRM MAIN CARRIER/MAIN BEAM
- 4 STATION 42 TRANSMITTER ON - START TUNING SWEEP
- 5 STATION 42 COMPLETE TRANSMITTER SWEEP - CONFIRM TWO-WAY LOCK ON MAIN CARRIER
STATION 44 - CONFIRM REACQUISITION THREE-WAY
- 6 STATION 42 CONFIRM TRACKING RATES AND GO AUTO TRACK. TELEMETRY FROM 5 OR 6 AT PROJECT DISCRETION
- 7 STATION 42 COMMAND MODULATION ON - CALIBRATION 2 MODE - GREEN FOR COMMAND
- 8 STATION 42 REMAIN TRANSMITTING - 5-BAND ACQUISITION ANTENNA RECEIVER 5 5-BAND CASSEGRAIN MONOPULSE AUTO TRACK
- 9 STATION 42 TRANSFER UPLINK TO STATION 44 - STATION 44 TRANSMITTER ON AT 1-kW 5-BAND CASSEGRAIN MONOPULSE
(STATION 42 RECONFIGURE TRANSMITTER TO 5-BAND CASSEGRAIN MONOPULSE/5-BAND CASSEGRAIN MONOPULSE TO MASER IN TELEMETRY AND COMMAND PROCESSOR-3 TELEMETRY SYSTEM TO HIGH-SPEED DATA LINE)
- 10 STATION 44 TRANSFER UPLINK BACK TO STATION 42 - STATION 42 TRANSMITTER ON AT 10-kW 5-BAND CASSEGRAIN MONOPULSE
(STATION 44 RECONFIGURE 5-BAND CASSEGRAIN MONOPULSE TO MASER IN TELEMETRY AND COMMAND PROCESSOR-1 TELEMETRY SYSTEM TO HIGH-SPEED DATA LINE)

Fig. 59. Initial acquisition strategy (time line)

uplink capability (command, ranging, etc.) with the spacecraft. The initial acquisition sequence was to occur shortly after spacecraft injection into the trans-Mars trajectory and separation from the launch vehicle.

Although "prime crews" were designated for the actual launches, initial acquisition Operational Verification Tests were conducted with all crews at Stations 42 and 44, as well as the Network Operations Teams at the Jet Propulsion Laboratory. Dual-station initial acquisition Operational Verification Tests with simulated anomalies also were conducted.

An Operational Readiness Test was conducted by the Project on August 6, providing a final check on the ability of the Stations, the Ground Communications Facility, and the Network Operations Control Center to support the launch and cruise phases of the Viking mission.

G. LAUNCH OF VIKINGS A AND B

1. Viking A

The first launch delay for Viking A occurred on August 11, the original launch date. A thrust vector control valve on the Titan solid rocket booster stage did not respond properly during checkout, and launch was scrubbed for that day. With the valve replaced, launch was rescheduled for August 14. However, on August 13, the Orbiter batteries were found to have fallen from their normal charge of 37 volts down to 9 volts. (A rotary switch aboard the Orbiter had been turned on sometime after the launch postponement.) The entire Viking A Spcaecraft was then removed from the launch vehicle for disassembly and checking. The already tested Viking B Spacecraft was used as a replacement. The necessary work of mating and checking was completed and approved on August 15; the launch was scheduled for August 20. Between August 17 and 19, the Deep Space Network and Viking Mission Control and Computing Center performed an Operational Verification Test with Stations 11, 43, and 61 an Initial Acquisition Test with Station 42, and a Configuration Verification Test with Stations 42 and 44. Then, according to plan, the stations were "frozen" again.

The successful liftoff of Viking A (now Viking 1) occurred at 21:22:00 (Greenwich Mean Time) on August 20. Every aspect of the launch sequence was nominal.

Initial acquisition of the spacecraft by the Network (Australia's Station 42 with Station 44 as backup) occurred at 22:09:56 (Greenwich Mean Time). Following initial acquisition, the Deep Space Network provided normal cruise coverage.

The Near-Earth minus count and launch operations for both Vikings A and B Missions are in Volume II of this report.

2. Viking B

The Viking B launch date had been slipped to September 3 as a result of the Viking A launch date change. But, during routine spacecraft checks on September 2, a degradation of 3 db in the receiver uplink was detected on the high-gain antenna. To investigate this anomaly, the spacecraft was demated from the launch vehicle and the shroud removed. The problem was cleared after a complete set of new hardware (cables, joints, etc.) was installed between the high-gain antenna and the diplexer. The spacecraft was then rechecked and remated to the launch vehicle. The revised launch date was now September 9, and all systems were ready. To insure optimum performance, additional prelaunch initial acquisition testing was performed with Stations 42 and 44. These stations again entered a configuration freeze condition prior to launch.

Viking B had successful liftoff at 18:39:00 (Greenwich Mean Time) on September 9. Initial acquisition of Viking B (now Viking 2) by Station 42 occurred at 19:27:26 (Greenwich Mean Time) as expected, and the Network began providing normal cruise coverage.

3. Spacecraft Identification

Because of the interchange of spacecraft after the Orbiter No. 1 battery anomaly on August 12, 1975, there was considerable confusion as to the correct spacecraft and mission identification codes. This posed a problem for the Network, in that all the orbiter and lander uplink and downlink radio frequencies were associated in the operations documentation throughout the entire Network with what had suddenly become obsolete spacecraft identification codes.

On August 14, the Mission director issued the revised Spacecraft identification matrix shown in Table 12 to all elements of the Project. The Network informed all stations to update all existing documentation and instructions.

Despite the last minute change, there were no reported instances of incorrect frequencies or identification numbers being used by the Network in the course of the launch and early cruise operations.

Table 12. Viking identification matrix for flight spacecraft

Mission ID		Spacecraft nomenclature				Spacecraft hardware serial Nos.	Radio channel assigned frequency
Prelaunch	Postlaunch	Prelaunch		Postlaunch			
Mission A	Mission 1	Viking spacecraft B	Viking Orbiter B	Viking Spacecraft 1	Viking Orbiter 1	VO-1	S-band: 9A, spacecraft transmit 9B, Spacecraft receive X-band: 9C, Ground station receive
			Viking Lander B		Viking Lander 1		
Mission B	Mission 2	Viking Spacecraft A	Viking Orbiter A	Viking Spacecraft 2	Viking Orbiter 2	VO-2	S-band: 20A, Spacecraft transmit 20B, Spacecraft receive X-band: 20C, Ground station receive
			Viking Lander A		Viking Lander 2		

REFERENCES

1. Hall, J.R., and Gatz, E.C., The Deep Space Network, Space Programs Summary 37-59, Vol. II, p. 32. Jet Propulsion Laboratory, Pasadena, California, Sept. 30, 1969.
2. Mudgway, D.J., The Deep Space Network, Space Programs Summary 37-61, Vol. II, p. 26. Jet Propulsion Laboratory, Pasadena, California, Jan. 31, 1970.
3. Mudgway, D.J., The Deep Space Network, Space Programs Summary 37-62, Vol. II, p. 12. Jet Propulsion Laboratory, Pasadena, California, Mar. 31, 1970.
4. Davis, E.K., The Deep Space Network, Technical Report 32-1526, Vol. V, p. 24. Jet Propulsion Laboratory, Pasadena, California, Oct. 15, 1971.
5. Mudgway, D.J., The Deep Space Network, Technical Report 32-1526, Vol. XI, p. 19. Jet Propulsion Laboratory, Pasadena, California, Oct. 15, 1972.
6. Mudgway, D.J., The Deep Space Network, Technical Report 32-1526, Vol. XII, p. 14. Jet Propulsion Laboratory, Pasadena, California, Dec. 15, 1972.
7. Mudgway, D.J., The Deep Space Network, Technical Report 32-1526, Vol. XV, p. 10. Jet Propulsion Laboratory, Pasadena, California, June 15, 1973.
8. Mudgway, D.J., The Deep Space Network, Technical Report 32-1526, Vol. XIII, p. 29. Jet Propulsion Laboratory, Pasadena, California, Feb. 15, 1973.
9. Mudgway, D.J., and Johnston, D.W., The Deep Space Network, Technical Report 32-1526, Vol. XIX, p. 10. Jet Propulsion Laboratory, Pasadena, California, Feb. 15, 1974.
10. Bryan, A.I., The Deep Space Network Progress Report 42-24, p. 9. Jet Propulsion Laboratory, Pasadena, California, Dec. 15, 1974.
11. Bryan, A.I., The Deep Space Network Progress Report 42-30, p. 16. Jet Propulsion Laboratory, Pasadena, California, Dec. 15, 1975.

BIBLIOGRAPHY

- Anderson, J. D., Null, G. W., and Thornton, C. T., *The Evaluation of Certain Astronomical Constants from the Radio Tracking of Mariner II*, Technical Report 32-476, Jet Propulsion Laboratory, Pasadena, Calif., reprinted from *Progr. Astronaut. Aeronaut.*, Vol. 14, 1964.
- Anderson, J. D., *Determination of the Masses of the Moon and Venus and the Astronomical Unit from Radio Tracking Data of the Mariner II Spacecraft*, Technical Report 32-816, Jet Propulsion Laboratory, Pasadena, Calif., July 1, 1967.
- Anderson, J. D., et al., "The Radius of Venus as Determined by Planetary Radar and Mariner V Radio Tracking Data," *J. Atmos. Sci.*, pp. 1171-1174, Sept. 25, 1968.
- Anderson, J. D., and Hilt, D. E., "Improvement of Astronomical Constants and Ephemerides from Pioneer Radio Tracking Data," *AIAA J.*, Vol. 7, No. 6, pp. 1048-1054, June 1969.
- Anderson, J. D., "Determination of Astrodynamical Constants and a Test of the General Relativistic Time Delay With S-Band Range and Doppler Data From Mariners 6 and 7," *Space Research*, Vol. XI, pp. 105-112, Akademie-Verlag, Berlin, 1971.
- Barnum, P. W., et al., *Tracking and Data System Support for the Mariner Mars 1971 Mission: Orbit Insertion Through End of Primary Mission*, Technical Memorandum 33-523, Vol. III, Jet Propulsion Laboratory, Pasadena, Calif., May 15, 1973.
- Barnum, P. W., and Renzetti, N. A., *Tracking and Data System Support for the Mariner Mars 1971 Mission: Extended Mission Operations*, Technical Memorandum 33-523, Vol. IV, Jet Propulsion Laboratory, Pasadena, Calif., Dec. 15, 1973.
- Barton, W. R., and Miller, R. B., *Tracking and Data System Support for the Pioneer Project: Pioneer 11—Prelaunch Planning Through Second Trajectory Correction: to May 1, 1973*, Technical Memorandum 33-584, Vol. II, Jet Propulsion Laboratory, Pasadena, Calif., Mar. 15, 1975.
- Bartos, K. P., et al., *Implementation of the 64-Meter-Diameter Antennas at the Deep Space Stations in Australia and Spain*, Technical Memorandum 33-692, Jet Propulsion Laboratory, Pasadena, Calif., Jan. 15, 1975.
- Bathker, D. A., *Radio-Frequency Performance of an 85-ft Ground Antenna: X-Band*, Technical Report 32-1300, Jet Propulsion Laboratory, Pasadena, Calif., July 1, 1968.
- Bathker, D. A., *Radio Frequency Performance of a 210-ft Ground Antenna: X-Band*, Technical Report 32-1417, Jet Propulsion Laboratory, Pasadena, Calif., Dec. 15, 1969.
- Bathker, D. A., *Predicted and Measured Power Density Description of a Large Ground Microwave System*, Technical Memorandum 33-433, Jet Propulsion Laboratory, Pasadena, Calif., Apr. 15, 1971.
- Bathker, D. A., Brown, D. W., and Petty, S. M., *Single- and Dual-Carrier Microwave Noise Abatement in the Deep Space Network*, Technical Memorandum 33-733, Jet Propulsion Laboratory, Pasadena, Calif., Aug. 1, 1975.

- Baumert, L., et al., *Coding Theory and Its Applications to Communications Systems*, Technical Report 32-67, Jet Propulsion Laboratory, Pasadena, Calif., Mar. 31, 1961.
- Baumgartner, W. S., *High-Power CW Radar Transmitter*, Technical Report 32-656, Jet Propulsion Laboratory, Pasadena, Calif., Sept. 1, 1964.
- Berman, A. L., *Tracking System Data Analysis Report, Ranger VII Final Report*, Technical Report 32-719, Jet Propulsion Laboratory, Pasadena, Calif., June 1, 1965.
- Berman, A. L., and Rockwell, S. T., *New Optical and Radio Frequency Angular Tropospheric Refraction Models for Deep Space Applications*, Technical Report 32-1601, Jet Propulsion Laboratory, Pasadena, Calif., Nov. 1, 1975.
- Biber, K. W., and Whittlesey, A. C., *Description and Analysis of 890-MHz Noise-Measuring Equipment*, Technical Report 32-898, Jet Propulsion Laboratory, Pasadena, Calif., Mar. 31, 1966.
- Born, G. H., et al., "The Determination of the Satellite Orbit of Mariner 9," *Celest. Mech.*, Vol. 9, No. 3, pp. 395-414, May 1974.
- Brockman, M. H., et al., *Extraterrestrial Radio Tracking and Communication*, External Publication 808, Jet Propulsion Laboratory, Pasadena, Calif., Nov. 12, 1959. Also available in *Proc. IRE*, Vol. 48, 1960.
- Brockman, M. H., and Posner, E. C., *Power Requirements for Deep-Space Telecommunication Links*, Technical Report 32-1395, Jet Propulsion Laboratory, Pasadena, Calif., reprinted from *IEEE Spectrum*, Vol. 6, No. 3, pp. 95-99, Mar. 1969.
- Bryan, A. I., "Summary Report on the Deep Space Network/Viking Flight Project Telecommunications Compatibility," in *The Deep Space Network Progress Report 42-24*, p. 9. Jet Propulsion Laboratory, Pasadena, California, Dec. 15, 1974.
- Bunce, R. C., *Unified S-Band Receiver-Exciter Subsystem*, Technical Report 32-809, Jet Propulsion Laboratory, Pasadena, Calif., Sept. 15, 1968.
- Butman, S., "A General Formulation of Linear Feedback Communication Systems with Solutions," *IEEE Trans. Inform. Theor.*, Vol. IT-15, No. 3, pp. 392-400, May 1969.
- Butman, S., "Rate Distortion Over Band-Limited Feedback Channels," *IEEE Trans. Inform. Theor.*, Vol. IT-17, No. 1, pp. 110-112, Jan. 1971.
- Butman, S., and Timor, U., "Interplex—An Efficient Multichannel PSK/PM Telemetry System," *IEEE Trans. Commun.*, Vol. COM-20, No. 3, pp. 415-419, June 1972.
- Cain, D. L., and Hamilton, T. W., *Determination of Tracking Station Locations by Doppler and Range Measurements to an Earth Satellite*, Technical Report 32-534, Jet Propulsion Laboratory, Pasadena, Calif., Feb. 1, 1964.
- Carey, C. N., and Sjogren, W. L., *Gravitational Inconsistency in the Lunar Theory: Confirmation by Radio Tracking*, Technical Report 32-1290, Pt. II, Jet Propulsion Laboratory, Pasadena, Calif., reprinted from *Science*, Vol. 160, No. 3830, pp. 875-876, May 24, 1968.

- Carpenter, R. L., *Study of Venus by CW Radar—1964 Results*, Technical Report 32-963, Jet Propulsion Laboratory, Pasadena, Calif., reprinted from *Astron. J.*, Vol. 71, No. 2, pp. 142-152, Mar. 1966.
- Carr, R. E., *The Jet Propulsion Laboratory Method of Tracking Lunar Probes*, External Publication 793, Jet Propulsion Laboratory, Pasadena, Calif., June 4, 1959.
- Chadwick, H. D., and Springett, J. C., "The Design of a Low Data Rate MSFK Communication System," *IEEE Trans. Commun. Technol.*, Vol. COM-18, No. 6, pp. 740-750, Dec. 1970.
- Chaney, W. D., *Final Mariner II Tracking System Data Analysis Report*, Technical Report 32-727, Jet Propulsion Laboratory, Pasadena, Calif., Sept. 1, 1965.
- Charles, F. J., and Lindsey, W. C., *Some Analytical and Experimental Phase-Locked Loop Results for Low Signal-to-Noise Ratios*, Technical Report 32-1027, Jet Propulsion Laboratory, Pasadena, Calif., reprinted from *Proc. IEEE*, Vol. 54, No. 9, pp. 1152-1166, Sept. 1966.
- Clark, B. G., et al., "High Resolution Observations of Compact Radio Sources at 13 cm," *Astrophys. J.*, Vol. 161, pp. 803-809, Sept. 1970.
- Clauss, R. C., et al., *Total System Noise Temperature: 15°K*, Technical Report 32-691, Jet Propulsion Laboratory, Pasadena, Calif., Nov. 1964.
- Clauss, R. C., *A 2388-Mc Two-Cavity Maser for Planetary Radar*, Technical Report 32-583, Jet Propulsion Laboratory, Pasadena, Calif., reprinted from *Microwave J.*, Vol. 8, pp. 74-77, May 1965.
- Clauss, R. C., *A Traveling Wave Maser for Deep Space Communication at 2295 and 2388 MHz*, Technical Report 32-1072, Jet Propulsion Laboratory, Pasadena, Calif., Feb. 15, 1967.
- Cohen, M. H., et al., "Compact Radio Source in the Nucleus of M87," *Astrophys. J.*, Vol. 158, No. 2, Pt. 2, pp. L83-L85, Nov. 1969.
- Coyner, J. V., Jr., *Radial Rib Antenna Surface Deviation Analysis Program*, Technical Memorandum 33-518, Jet Propulsion Laboratory, Pasadena, Calif., Dec. 15, 1971.
- Curkendall, D. W., and McReynolds, S. R., "A Simplified Approach for Determining the Information Content of Radio Tracking Data," *J. Spacecraft Rockets*, Vol. 6, No. 5, pp. 520-525, May 1969.
- Curkendall, D. W., and Stephenson, R. R., "Earthbased Tracking and Orbit Determination—Backbone of the Planetary Navigation System," *Astronaut. Aeronaut.*, Vol. 7, No. 5, pp. 30-36, May 1970.
- Curkendall, D. W., "Planetary Navigation: The New Challenges," *Astronaut. Aeronaut.*, Vol. 7, No. 5, pp. 26-29, May 1970.
- "The Deep Space Network—An Instrument for Radio Navigation for the Mariner Mission to Mars—1969," *Proceedings of the Second International Conference of STM and AERA*, Reidel Publishing Company, Holland, May 1969.
- Description of the Deep Space Network Operational Capabilities as of January 1, 1966*, Technical Memorandum 33-255, Jet Propulsion Laboratory, Pasadena, Calif., July 1, 1966.

- Description of World Network for Radio Tracking of Space Vehicles*, Publication 135, Jet Propulsion Laboratory, Pasadena, Calif., July 1, 1958.
- Didday, R. L., and Lindsey, W. C., *Subcarrier Tracking Methods and Communication System Design*, Technical Report 32-1317, Jet Propulsion Laboratory, Pasadena, Calif., reprinted from *IEEE Trans. Commun. Technol.*, Vol. COM-16, No. 4, pp. 541-550, Aug. 1968.
- Downs, G. S., and Reichley, P. E., "Observations of Interstellar Scintillations of Pulsar Signals at 2388 MHz," *Astrophys. J.*, Vol. 163, No. 1, Pt. 2, pp. L11-L16, Jan. 1971.
- Downs, G. S., et al., "Mars Radar Observation, A Preliminary Report," *Science*, Vol. 174, No. 4016, pp. 1324-1327, Dec. 24, 1971.
- Downs, G. S., et al., "Martian Topography and Surface Properties as Seen by Radar: The 1971 Opposition," *Icarus*, Vol. 18, No. 1, pp. 8-21, Jan. 1973.
- Downs, G. S., Reichley, P. E., and Morris, G. A., "Pulsar Detections at Frequencies of 8.4 and 15.1 GHz," *Astrophys. J.*, Vol. 181, No. 3, Part 2, pp. L143-L146, May 1, 1973.
- Easterling, M., *A Long-Range Precision Ranging System*, Technical Report 32-80, Jet Propulsion Laboratory, Pasadena, Calif., July 10, 1961.
- Easterling, M., *Methods for Obtaining Velocity and Range Information from CW Radars*, Technical Report 32-657, Jet Propulsion Laboratory, Pasadena, Calif., Sept. 1, 1964.
- Easterling, M., and Goldstein, R., *The Effect of the Interplanetary Medium on S-Band Telecommunications*, Technical Report 32-825, Jet Propulsion Laboratory, Pasadena, Calif., Sept. 1, 1965.
- Edelson, R. E. (ed.), *Telecommunications Systems Design Techniques Handbook*, Technical Memorandum 33-571, Jet Propulsion Laboratory, Pasadena, Calif., July 15, 1972.
- Efron, L., and Solloway, C. B., *Proceedings of the Conference on Scientific Applications of Radio and Radar Tracking in the Space Program*, Technical Report 32-1475, Jet Propulsion Laboratory, Pasadena, Calif., July 1, 1970.
- Eimer, M., and Stevens, R., *Tracking and Data Handling for the Pioneer III and Pioneer IV Firings*, External Publication 701, Jet Propulsion Laboratory, Pasadena, Calif., Aug. 14, 1959.
- Esposito, P. B., and Wong, S. K., "Geocentric Gravitational Constant Determined from Mariner 9 Radio Tracking Data," paper presented at the International Symposium on Earth Gravity Models (American Geophysical Union, NASA), St. Louis, Aug. 1972.
- Fearey, J. P., and Renzetti, N. A., "Navigation Results on the Mariner Mars Mission to Mars 1969," International Navigation Conference, Hamburg, Oct. 1969.
- Fjeldbo, G., Kliore, A. J., and Seidel, B. L., "Bistatic Radar Measurements of the Surface of Mars with Mariner 1969," *Icarus*, Vol. 16, No. 3, pp. 502-508, June 1972.
- Fjeldbo, G., and Eshleman, V. R., "Radio Occultation Measurements and Interpretations," in *The Atmospheres of Venus and Mars*, p. 225, Gordon and Breach, Science Publishers, Inc., New York, N.Y., 1968.

- Fjeldbo, G., "Radio Occultation Experiments Planned for Pioneer and Mariner Missions to the Outer Planets," *Planet. Space Sci.*, Vol. 21, No. 9, pp. 1533-1547, Sept. 1973.
- Flanagan, F. M., et al., *Deep Space Network Support of the Manned Space Flight Network for Apollo: 1962-1968*, Technical Memorandum 33-452, Vol. I, Jet Propulsion Laboratory, Pasadena, Calif., July 1970.
- Flanagan, F. M., et al., *Deep Space Network Support of the Manned Space Flight Network for Apollo: 1969-1970*, Technical Memorandum 33-452, Vol. II, Jet Propulsion Laboratory, Pasadena, Calif., May 1, 1971.
- Fredricksen, H., *Error Correction for Deep Space Network Teletype Circuits*, Technical Report 32-1275, Jet Propulsion Laboratory, Pasadena, Calif., June 1, 1968.
- Gary, B., Olsen, E. T., and Rosenkranz, P. W., "Radio Observations of Cygnus X-3 and the Surrounding Region," *Nature Phys. Sci.*, Vol. 239, No. 95, pp. 128-130, Oct. 23, 1972.
- Gates, C. R., and Johnson, M. S., *A Study of On-Site Computing and Data Processing for a World Tracking Network*, Publication 154, Jet Propulsion Laboratory, Pasadena, Calif., Feb. 9, 1959.
- Georgevic, R. M., *Mathematical Model of the Solar Radiation Force and Torques Acting on the Components of a Spacecraft*, Technical Memorandum 33-494, Jet Propulsion Laboratory, Pasadena, Calif., Oct. 1, 1971.
- Goldstein, R., Stevens, R., and Victor, W. K., *Radar Exploration of Venus: Goldstone Observatory Report for October-December 1962*, Technical Report 32-396, Jet Propulsion Laboratory, Pasadena, Calif., Mar. 1, 1965.
- Goldstein, R. M., *The Analysis of Uncooperative Radar Targets*, Technical Report 32-658, Jet Propulsion Laboratory, Pasadena, Calif., Sept. 1, 1964.
- Goldstein, R. M., et al., *The Superior Conjunction of Mariner IV*, Technical Report 32-1092, Jet Propulsion Laboratory, Pasadena, Calif., Apr. 1, 1967.
- Goldstein, R. M., "Radar Time-of-Flight Measurements to Venus," *Astron. J.*, Vol. 73, No. 9, Aug. 1968.
- Goldstein, R. M., et al., "Preliminary Radar Results of Mars," *Radio Sci.*, Vol. 5, No. 2, pp. 475-478, Feb. 1970.
- Goldstein, R. M., and Rumsey, H., "A Radar Snapshot of Venus," *Science*, Vol. 169, Sept. 1970.
- Goldstein, R. M., "Radar Observations of Mercury," *Astron. J.*, Vol. 76, No. 10, pp. 1152-1154, Dec. 1971.
- Goldstein, R. M., Holdridge, D. B., and Lieske, J. H., "Minor Planets and Related Objects: XII. Radar Observations of (1685) Toro," *Astron. J.*, Vol. 78, No. 6, pp. 508-509, Aug. 1973.
- Golomb, S. W., "New Problems of Space Communications: Part I. Beware of the Tigers," *Astronautics*, Vol. 7, No. 6, p. 19, June 1962.
- Golomb, S. W., "New Problems in Space Communications: Part 3," *Astronautics*, Vol. 7, No. 8, p. 26, Aug. 1962.
- Golomb, S. W., "Ferretting Signals Out of Noise," *Int. Sci. Technol.*, No. 22, pp. 72-82 and 120, Oct. 1963.

- Gordon, H. J., et al., *The Mariner 6 and 7 Flight Paths and Their Determination From Tracking Data*, Technical Memorandum 33-469, Jet Propulsion Laboratory, Pasadena, Calif., Dec. 1, 1970.
- Gottlieb, P., et al., "Lunar Gravity over Large Craters from Apollo 12 Tracking Data," *Science*, Vol. 168, No. 3930, pp. 477-479, Apr. 1970.
- Gray, R. M., and Tausworthe, R. C., "Frequency-Counted Measurements, and Phase Locking to Noise Oscillators," *IEEE Trans. Commun. Technol.*, Vol. COM-19, No. 1, pp. 21-30, Feb. 1971.
- Gubbay, J., et al., "Variations of Small Quasar Components at 2,300 MHz," *Nature*, Vol. 224, No. 5224, pp. 1094-1095, Dec. 1969.
- Gulkis, S., and Gary, B., "Circular Polarization and Total-Flux Measurements of Jupiter at 13.1 cm Wavelength," *Astron. J.*, Vol. 76, No. 1, pp. 12-16, Feb. 1971.
- Gulkis, S., et al., "Observations of Jupiter at 13-cm Wavelength During 1969 and 1971," *Icarus*, Vol. 18, No. 2, pp. 181-191, Feb. 1973.
- Hachenberg, O., et al., "The 100-meter Radio Telescope at Effelsberg," *Proc. IEEE*, Vol. 61, No. 9, pp. 1288-1295, Sept. 1973.
- Hall, J. R., and Easterling, M., "The Technology of Ground Stations in the Deep Space Network from 1958 to 1968," *IEEE Conf. Rec.*, Vol. 4, pp. 576-585, 1968.
- Hall, J. R., et al., "The General Problem of Data Return from Deep Space," *Space Sci. Rev.*, Vol. 8, pp. 595-664, 1968.
- Hall, J. R., *Tracking and Data System Support for Lunar Orbiter*, Technical Memorandum 33-450, Jet Propulsion Laboratory, Pasadena, Calif., Apr. 1970.
- Hamilton, T. W., et al., *The Ranger IV Flight Path and Its Determination From Tracking Data*, Technical Report 32-345, Jet Propulsion Laboratory, Pasadena, Calif., Sept. 15, 1962.
- Hartop, R. W., *Power Loss Between Arbitrarily Polarized Antennas*, Technical Report 32-457, Jet Propulsion Laboratory, Pasadena, Calif., Sept. 1, 1964.
- Havens, W. F., et al., *Scan Pointing Calibration for the Mariner Mars 1971 Spacecraft*, Technical Memorandum 33-556, Jet Propulsion Laboratory, Pasadena, Calif., Aug. 1, 1972.
- Heftman, K., and Renzetti, N. A., "Data Return Capabilities of the Deep Space Network in the 1970's," AIAA Paper 67-648, *Proceedings of the AIAA Space Program Issues of the 70's Meeting*, Aug. 1967.
- Higa, W. H., *Low-Level Microwave Mixing in Ruby*, Technical Report 32-1016, Jet Propulsion Laboratory, Pasadena, Calif., reprinted from *Proc. IEEE*, Vol. 54, No. 10, p. 1453, Oct. 1966.
- Higa, W. H., "Time Synchronization via Lunar Radar," *Proc. IEEE*, Vol. 60, No. 5, pp. 552-557, May 1972.
- Holmes, J. K., "On a Solution to the Second-Order Phase-Locked Loop," *IEEE Trans. Commun. Technol.*, Vol. COM-18, No. 2, pp. 119-126, Apr. 1970.
- Holmes, J. K., "First Slip Times Versus Static Phase Error Offset for the First and Passive Second-Order Phase-Locked Loop," *IEEE Trans. Commun. Technol.*, Vol. COM-19, No. 2, pp. 234-235, Apr. 1971.

- Holmes, J. K., and Tegnalia, C. R., *Digital Command System Second-Order Subcarrier Tracking Performance*, Technical Report 32-1540, Jet Propulsion Laboratory, Pasadena, Calif., Oct. 1, 1971.
- Holmes, J. K., "Performance of a First Order Transition Sampling Digital Phase-Locked Loop Using Random-Walk Models," *IEEE Trans. Commun.*, Vol. COM-20, No. 2, pp. 119-131, Apr. 1972.
- Hurd, W. J., and Anderson, T. O., *Digital Transition Tracking Symbol Synchronizer for Low SNR Coded Systems*, Technical Report 32-1488, Jet Propulsion Laboratory, Pasadena, Calif., reprinted from *IEEE Trans. Commun. Technol.*, Vol. COM-18, No. 2, pp. 141-147, Apr. 1970.
- Hurd, W. J., "An Analysis and Demonstration of Clock Synchronization by VLBI," *IEEE Trans. Instr. Meas.*, Vol. IM-23, No. 1, pp. 80-89, March 1974.
- Jaffe, R., and Rehtin, E., *Design and Performance of Phase-Lock Loops Capable of Near-Optimum Performance over a Wide Range of Input Signal and Noise Levels*, Progress Report 20-243, Jet Propulsion Laboratory, Pasadena, Calif., Dec. 1, 1954; also available in *IRE Trans. Inform. Theory*, No. 1, pp. 66-67, Mar. 1955.
- Jordan, J. F., "Orbit Determination for Powered Flight Space Vehicles on Deep Space Missions," *J. Spacecraft Rockets*, Vol. 6, No. 5, pp. 545-550, May 1969.
- Jordan, J. F., Melbourne, W. G., and Anderson, J. D., "Testing Relativistic Gravity Theories Using Radio Tracking Data From Planetary Orbiting Spacecraft," *Space Research XIII*, pp. 83-92, Akademie-Verlag, Berlin, 1973.
- Kellerman, K. I., et al., "High Resolution Observations of Compact Radio Sources at 13 Centimeters," *Astrophys. J.*, Vol. 161, No. 3, pp. 803-809, Sept. 1970.
- Kelly, A. J., *Microwave Probe for Plasma Plumes*, Technical Report 32-625, Jet Propulsion Laboratory, Pasadena, Calif., Feb. 1965.
- Kliore, A., Cain, D. L., and Hamilton, T. W., *Determination of Some Physical Properties of the Atmosphere of Mars from Changes in the Doppler Signal of a Spacecraft on an Earth-Occultation Trajectory*, Technical Report 32-674, Jet Propulsion Laboratory, Pasadena, Calif., Oct. 15, 1964.
- Kliore, A., and Tito, D. A., *Radio Occultation Investigations of the Atmosphere of Mars*, Technical Report 32-1157, Jet Propulsion Laboratory, Pasadena, Calif., reprinted from *J. Spacecraft Rockets*, Vol. 4, No. 5, pp. 578-582, May 1967.
- Kliore, A., "Radio Occultation Measurements of the Atmospheres of Mars and Venus," in *The Atmospheres of Venus and Mars*, edited by J. C. Brandt and M. B. McElrow, p. 205, Gordon and Breach Science Publishers, Inc., New York, N.Y., 1968.
- Kliore, A. J., et al., "Summary of Mariner 6 and 7 Radio Occultation Results on the Atmosphere of Mars," *Space Research*, Vol. XI, pp. 165-175, Akademie-Verlag, Berlin, 1971.
- Kliore, A. J., et al., "Mariner 9 S-Band Martian Occultation Experiment: Initial Results on the Atmosphere and Topography of Mars," *Science*, Vol. 175, No. 4019, pp. 313-317, Jan. 1972.
- Kliore, A. J., et al., "The Atmosphere of Mars From Mariner 9 Radio Occultation Measurements," *Icarus*, Vol. 17, No. 2, pp. 484-516, Oct. 1972.

- Kliore, A. J., et al., "S Band Radio Occultation Measurements of the Atmosphere and Topography of Mars with Mariner 9: Extended Mission Coverage of Polar and Intermediate Latitudes," *J. Geophys. Res.*, Vol. 78, No. 20, pp. 4331-4351, July 10, 1973.
- Labrum, R. G., et al., *The Surveyor V, VI, and VII Flight Paths and Their Determination from Tracking Data*, Technical Report 32-1302, Jet Propulsion Laboratory, Pasadena, Calif., Dec. 1, 1968.
- Laeser, R. P., et al., *Tracking and Data System Support for the Mariner Mars 1971 Mission: Prelaunch Phase Through First Trajectory Correction Maneuver*, Technical Memorandum 33-523, Vol. I, Jet Propulsion Laboratory, Pasadena, Calif., Mar. 15, 1972.
- Layland, J. W., "On Optimal Signals for Phase-Locked Loops," *IEEE Trans. Commun. Technol.*, Vol. COM-17, No. 5, pp. 526-531, Oct. 1969.
- Layland, J. W., and Lushbaugh, W. A., "A Flexible High-Speed Sequential Decoder for Deep Space Channels," *IEEE Trans. Commun. Technol.*, Vol. COM-19 No. 5, pp. 813-820, Oct. 1971.
- Layland, J. W., "Buffer Management for Sequential Decoding," *IEEE Trans. Commun.*, Vol. COM-22, No. 10, pp. 1685-1690, Oct. 1974.
- Leavitt, R. K., *The Least-Squares Process of MEDIA for Computing DRVID Calibration Polynomials*, Technical Memorandum 33-542, Jet Propulsion Laboratory, Pasadena, Calif., May 15, 1972.
- Lesh, J. R., *Signal-to-Noise Ratios in Coherent Soft Limiters*, Technical Report 32-1589, Jet Propulsion Laboratory, Pasadena, Calif., Sept. 15, 1973.
- Lesh, J. R., "Signal-to-Noise Ratios in Coherent Soft Limiters," *IEEE Trans. Commun.*, Vol. COM-22, No. 6, pp. 803-811, June 1974.
- Levitt, B. K., "Optimum Frame Synchronization for Biorthogonally Coded Data," *IEEE Trans. Commun.*, Vol. COM-22, No. 8, pp. 1130-1134, Aug. 1974.
- Levy, G. S., Ootshi, T. Y., and Seidel, B. L., *Ground Instrumentation for Mariner IV Occultation Experiment*, Technical Report 32-984, Jet Propulsion Laboratory, Pasadena, Calif., Sept. 15, 1966.
- Levy, G. S., et al., *Lunar Range Radiation Patterns of a 210-Foot Antenna at S-Band*, Technical Report 32-1079, Jet Propulsion Laboratory, Pasadena, Calif., reprinted from *IEEE Trans. Antennas Propagation*, Vol. AP-15, No. 2, pp. 311-313, Mar. 1967.
- Levy, G. S., et al., *The Ultra Cone: An Ultra-Low-Noise Space Communication Ground Radio-Frequency System*, Technical Report 32-1340, Jet Propulsion Laboratory, Pasadena, Calif., reprinted from *IEEE Trans. Microwave Theor. Tech.*, Vol. MTT-16, No. 9, pp. 596-602, Sept. 1968.
- Levy, G. S., et al., "Pioneer 6: Measurement of Transient Faraday Rotation Phenomena Observed During Solar Occultation," *Science*, Vol. 166, No. 3905, pp. 596-598, Oct. 1969.
- Lieske, J. H., and Null, G. W., "Icarus and the Determination of Astronomical Constants," *Astron. J.*, Vol. 74, No. 2, Mar. 1969.
- Lieske, J. H., et al., "Simultaneous Solution for the Masses of the Principal Planets from Analysis of Optical Radar and Radio Tracking Data," *Celest. Mech.*, Vol. 4, No. 2, pp. 233-245, Oct. 1971.

- Lindsey, W. C., *Optimum and Suboptimum Frequency Demodulation*, Technical Report 32-637, Jet Propulsion Laboratory, Pasadena, Calif., June 15, 1964.
- Lindsey, W. C., *Improvements to be Realized Through the Use of Block-Coded Communication Systems*, Technical Report 32-947, Jet Propulsion Laboratory, Pasadena, Calif., reprinted from *IEEE Trans. Aerosp. Electron. Syst.*, Vol. AES-2, No. 3, pp. 364-366, May 1966.
- Lindsey, W. C., *Phase-Shift-Keyed Signal Detection with Noisy Reference Signals*, Technical Report 32-968, Jet Propulsion Laboratory, Pasadena, Calif., reprinted from *IEEE Trans. Aerosp. Electron. Syst.*, Vol. AES-2, No. 4, pp. 393-401, July 1966.
- Lindsey, W. C., *A Theory for the Design of One-Way and Two-Way Phase-Coherent Communication Systems: Phase-Coherent Tracking Systems*, Technical Report 32-986, Jet Propulsion Laboratory, Pasadena, Calif., July 15, 1969.
- Lindsey, W. C., *Optimal Design of One-Way and Two-Way Coherent Communication Links*, Technical Report 32-988, Jet Propulsion Laboratory, Pasadena, Calif., reprinted from *IEEE Trans. Commun. Technol.*, Vol. COM-14, No. 4, pp. 418-431, Aug. 1966.
- Lindsey, W. C., and Charles, F. J., *A Model Distribution for the Phase Error in Second-Order Phase-Locked Loops*, Technical Report 32-1017, Jet Propulsion Laboratory, Pasadena, Calif., reprinted from *IEEE Trans. Commun. Technol.*, Vol. COM-14, No. 10, pp. 662-664, Oct. 1966.
- Lindsey, W. C., *Performance of Phase-Coherent Receivers Preceded by Bandpass Limiters*, Technical Report 32-1162, Jet Propulsion Laboratory, Pasadena, Calif., Sept. 15, 1967.
- Lindsey, W. C., "Block Coding for Space Communications," *IEEE Trans. Commun. Technol.*, Vol. COM-17, No. 2, pp. 217-225, Apr. 1969.
- Lindsey, W. C., *Block-Coded Communications*, Technical Report 32-1380, Jet Propulsion Laboratory, Pasadena, Calif., Aug. 15, 1969.
- Lindsey, W. C., *Nonlinear Analysis of Generalized Tracking Systems*, Technical Report 32-1453, Jet Propulsion Laboratory, Pasadena, Calif., reprinted from *Proc. IEEE*, Vol. 57, No. 10, pp. 1705-1722, Oct. 1969.
- Lindsey, W. C., and Simon, M. K., "The Effect of Loop Stress on the Performance of Phase-Coherent Communication Systems", *IEEE Trans. Commun. Technol.*, Vol. COM-18, No. 5, pp. 569-588, Oct. 1970.
- Lindsey, W. C., and Simon, M. K., "Carrier Synchronization and Detection of Polyphase Signals," *IEEE Trans. Commun.*, Vol. COM-20, No. 3, pp. 441-454, June 1972.
- Lindsey, W. C., and Simon, M. K., "L-Orthogonal Signal Transmission and Detection," *IEEE Trans. Commun.*, Vol. COM-20, No. 5, pp. 953-960, Oct. 1972.
- Lindsey, W. C., and Simon, M. K., "On the Detection of Differentially Encoded Polyphase Signals," *IEEE Trans. Commun.*, Vol. COM-20, No. 6, pp. 1121-1128, Dec. 1972.
- Lindsey, W. C., *Synchronization Systems in Communication and Control*, Prentice-Hall, Inc., Englewood Cliffs, N. J., 1972.

- Lindsey, W. C., and Tausworthe, R. C., *A Bibliography of the Theory and Application of the Phase-Lock Principle*, Technical Report 32-1581, Jet Propulsion Laboratory, Pasadena, Calif., Apr. 1, 1973.
- Lindsey, W. C., and Simon, M. K., *Telecommunication Systems Engineering*, Prentice-Hall, Inc., Englewood Cliffs, N. J., 1973.
- Lorell, J., Anderson, J. D., and Sjogren, W. L., *Characteristics and Format of the Tracking Data to Be Obtained by the NASA Deep Space Instrumentation Facility for Lunar Orbiter*, Technical Memorandum 33-230, Jet Propulsion Laboratory, Pasadena, Calif., June 15, 1965.
- Lorell, J., Sjogren, W. L., and Boggs, D., *Compressed Tracking Data Used for First Iteration in Selenodesy Experiment, Lunar Orbiters I and II*, Technical Memorandum 33-343, Jet Propulsion Laboratory, Pasadena, Calif., May 1, 1967.
- Lorell, J., and Sjogren, W. L., *Lunar Orbiter Data Analysis*, Technical Report 32-1220, Jet Propulsion Laboratory, Pasadena, Calif., Nov. 15, 1967.
- Lorell, J., *Lunar Orbiter Gravity Analysis*, Technical Report 32-1387, Jet Propulsion Laboratory, Pasadena, Calif., June 15, 1969.
- Lorell, J., et al., "Icarus: Celestial Mechanics Experiment for Mariner," *Int. J. Sol. Sys.*, Vol. 12, Jan. 1970.
- Lorell, J., and Laing, P. A., *Compilation of Lunar Orbiter Tracking Data Used for Long-Term Selenodesy*, Technical Memorandum 33-419, Jet Propulsion Laboratory, Pasadena, Calif., Feb. 1, 1970.
- Lorell, J., "Estimation of Gravity Field Harmonics in the Presence of Spin-Axis Direction Error Using Radio Tracking Data," *J. Astronaut. Sci.*, Vol. XX, No. 1, pp. 44-54, Aug. 1972.
- Ludwig, A. C., et al., *Gain Calibration of a Horn Antenna Using Pattern Integration*, Technical Report 32-1572, Jet Propulsion Laboratory, Pasadena, Calif., Oct. 1, 1972.
- Madrid, G. A., et al., *Tracking System Analytic Calibration Activities for the Mariner Mars 1971 Mission*, Technical Report 32-1587, Jet Propulsion Laboratory, Pasadena, Calif., Mar. 1, 1974.
- Martin, D. P., *A Combined Radar-Radiometer With Variable Polarization*, Technical Memorandum 33-570, Jet Propulsion Laboratory, Pasadena, Calif., Oct. 15, 1972.
- Mathison, R. P., *Tracking Techniques for Interplanetary Spacecraft*, Technical Report 32-284, Jet Propulsion Laboratory, Pasadena, Calif., Aug. 1, 1962.
- McEliece, R. J., *Optimal Communications Nets*, Technical Report 32-697, Jet Propulsion Laboratory, Pasadena, Calif., Apr. 15, 1965.
- McNeal, C. E., *Ranger V Tracking Systems Data Analysis Final Report*, Technical Report 32-702, Jet Propulsion Laboratory, Pasadena, Calif., Apr. 15, 1965.
- Melbourne, W. G., et al., *Constants and Related Information for Astrodynamical Calculations*, Technical Report 32-1306, Jet Propulsion Laboratory, Pasadena, Calif., July 15, 1968.
- Melbourne, W. G., "Planetary Ephemerides," *Astronaut. Aeronaut.*, Vol. 7, No. 5, pp. 38-43, May 1970.

- Merrick, W. D., et al., *Deep Space Communications*, Technical Release 34-10, Jet Propulsion Laboratory, Pasadena, Calif., Jan. 29, 1960; also available in *IRE Trans. Mil. Electron.*, Vol. MIL-4, No. 2-3, pp. 158-163, April-June 1960.
- Miller, L., et al., *The Atlas-Centaur VI Flight Path and Its Determination from Tracking Data*, Technical Report 32-911, Jet Propulsion Laboratory, Pasadena, Calif., Apr. 15, 1966.
- Miller, R. B., *Tracking and Data System Support for the Pioneer Project: Pioneers 6-9. Extended Missions: July 1, 1972-July 1, 1973*, Technical Memorandum 33-426, Vol. XII, Jet Propulsion Laboratory, Pasadena, Calif., March 1, 1974.
- Miller, R. B., *Tracking and Data System Support for the Pioneer Project: Pioneer 10-From April 1, 1972, Through the Jupiter Encounter Period, January 1974*, Technical Memorandum 33-584, Vol. III, Jet Propulsion Laboratory, Pasadena, Calif., June 15, 1975.
- Miller, R. B., et al., *Tracking and Data System Support for the Pioneer Project: Pioneer 10-From January 1974 to January 1975; Pioneer 11-From May 1, 1973 Through Jupiter Encounter Period, January 1975*, Technical Memorandum 33-584, Vol. IV, Jet Propulsion Laboratory, Pasadena, Calif., Dec. 1, 1975.
- Moyer, T. D., *Mathematical Formulation of the Double-Precision Orbit Determination Program (DPODP)*, Technical Report 32-1527, Jet Propulsion Laboratory, Pasadena, Calif., May 17, 1971.
- Mudgway, D. J., "Viking Mission Support," in *The Deep Space Network Progress Report*, Technical Report 32-1526, Vol. XII, p. 14. Jet Propulsion Laboratory, Pasadena, California, Nov. 15, 1972.
- Mudgway, D. J., "Viking Mission Support," in *The Deep Space Network Progress Report*, Technical Report 32-1526, Vol. XII, p. 29. Jet Propulsion Laboratory, Pasadena, California, Jan. 15, 1973.
- Mudgway, D. J., "Viking Mission Support," in *The Deep Space Network Progress Report*, Technical Report 32-1526, Vol. XV, p. 10. Jet Propulsion Laboratory, Pasadena, California, June 15, 1973.
- Mudgway, D. J., and Johnston, D. W., "Viking Mission Support," in *The Deep Space Network Progress Report*, Technical Report 32-1526, Vol. XVI, p. 13. Jet Propulsion Laboratory, Pasadena, California, Aug. 15, 1973.
- Mudgway, D. J., and Johnston, D. W., "Viking Mission Support," in *The Deep Space Network Progress Report*, Technical Report 32-1526, Vol. XVII, p. 9. Jet Propulsion Laboratory, Pasadena, California, Oct. 15, 1973.
- Mudgway, D. J., and Johnston, D. W., "Viking Mission Support" in *The Deep Space Network Progress Report*, Technical Report 32-1526, Vol. XIX, p. 10. Jet Propulsion Laboratory, Pasadena, California, Feb. 15, 1974.
- Mudgway, D. J., and Johnston, D. W., "Viking Mission Support" in *The Deep Space Network Progress Report 42-22*, p. 5. Jet Propulsion Laboratory, Pasadena, California, Aug. 15, 1974.
- Mudgway, D. J., and Johnston, D. W., "Viking Mission Support" in *The Deep Space Network Progress Report 42-23*, p. 15. Jet Propulsion Laboratory, Pasadena, California, Oct. 15, 1974.
- Mudgway, D. J., "Viking Mission Support" in *The Deep Space Network Progress Report 42-25*, p. 37. Jet Propulsion Laboratory, Pasadena, California, Jan. 15, 1975.

- Mudgway, D. J., and Johnston, D. W., "Viking Mission Support" in *The Deep Space Network Progress Report 42-26*, p. 8. Jet Propulsion Laboratory, Pasadena, California, April 15, 1975.
- Mudgway, D. J., Bryan, A. I., Thorman, H. C., and Johnston, D. W., "Viking Mission Support," in *The Deep Space Network Progress Report 42-27*, p. 10. Jet Propulsion Laboratory, Pasadena, California, June 15, 1975.
- Mudgway, D. J., Bryan, A. I., and Johnston, D. W., "Viking Mission Support" in *The Deep Space Network Progress Report 42-28*, p. 11. Jet Propulsion Laboratory, Pasadena, California, July 15, 1975.
- Mudgway, D. J., Bryan, A. I., and Johnston, D. W., "Viking Mission Support" in *The Deep Space Network Progress Report 42-29*, p. 10. Jet Propulsion Laboratory, Pasadena, California, Oct. 15, 1975.
- Mudgway, D. J., and Johnston, D. W., "Viking Mission Support," in *The Deep Space Network Progress Report 42-30*, p. 57. Jet Propulsion Laboratory, Pasadena, California, December 15, 1975.
- Muhleman, D. O., *Relationship Between the System of Astronomical Constants and the Radar Determinations of the Astronomical Unit*, Technical Report 32-477, Jet Propulsion Laboratory, Pasadena, Calif., Jan. 15, 1964.
- Muhleman, D. O., Goldstein, R., and Carpenter, R., *A Review of Radar Astronomy—Parts I, II*, Technical Report 32-824, Jet Propulsion Laboratory, Pasadena, Calif., Jan. 30, 1966, reprinted from *IEEE Spectrum*, Oct. and Nov. 1965.
- Muhleman, D. O., et al., *JPL Radar Range and Doppler Observations of Venus, 1961-1966*, Technical Report 32-1123, Jet Propulsion Laboratory, Pasadena, Calif., July 1, 1968.
- Muhleman, D. O., et al., "Radio Propagation Measurements of the Solar Corona and Gravitational Field: Applications to Mariner 6 and 7," in *Proceedings of the Conference on Experimental Tests of Gravitational Theories*, California Institute of Technology, Pasadena, Calif., Nov. 1970.
- Mulhall, B. D., et al., *Tracking System Analytic Calibration Activities for the Mariner Mars 1969 Mission*, Technical Report 32-1499, Jet Propulsion Laboratory, Pasadena, Calif., Nov. 15, 1970.
- Mulholland, J. D., and Sjogren, W. L., *Lunar Orbiter Ranging Data*, Technical Report 32-1087, Jet Propulsion Laboratory, Pasadena, Calif., reprinted from *Science*, Vol. 155, No. 3758, pp. 74-76, Jan. 6, 1967.
- Mulholland, J. D., *Proceedings of the Symposium on Observation, Analysis and Space Research Applications of the Lunar Motion*, Technical Report 32-1386, Jet Propulsion Laboratory, Pasadena, Calif., Apr. 1969.
- Muller, P. M., and Sjogren, W. L., *Consistency of Lunar Orbiter Residuals With Trajectory and Local Gravity Effects*, Technical Report 32-1307, Jet Propulsion Laboratory, Pasadena, Calif., Sept. 1, 1968.
- Muller, P. M., and Sjogren, W. L., *Mascons: Lunar Mass Concentrations*, Technical Report 32-1339, Jet Propulsion Laboratory, Pasadena, Calif., reprinted from *Science*, Vol. 161, No. 3842, pp. 680-684, Aug. 16, 1968.
- Muller, P. M., Sjogren, W. L., and Wollenhaupt, W. R., "Lunar Gravity: Apollo 15 Doppler Radio Tracking." *The Moon*, Vol. 10, No. 2, pp. 195-205, June 1974.

- The NASA/JPL 64-Meter-Diameter Antenna at Goldstone, California: Project Report*, Technical Memorandum 33-671, Jet Propulsion Laboratory, Pasadena, Calif., July 15, 1974.
- Newburn, R. L., Jr., et al., *Earth-Based Research on the Outer Planets During the Period 1970-1985*, Technical Report 32-1456, Jet Propulsion Laboratory, Pasadena, Calif., Mar. 15, 1970.
- Null, G. W., et al., *Mariner IV Flight Path and Its Determination From Tracking Data*, Technical Report 32-1108, Jet Propulsion Laboratory, Pasadena, Calif., Aug. 1, 1967.
- O'Neil, W. J., et al., *The Surveyor III and Surveyor IV Flight Paths and Their Determination From Tracking Data*, Technical Report 32-1292, Jet Propulsion Laboratory, Pasadena, Calif., Aug. 15, 1968.
- O'Neil, W. J., et al., *Mariner 9 Navigation*, Technical Report 32-1586, Jet Propulsion Laboratory, Pasadena, Calif., Nov. 13, 1973.
- Otoshi, T. Y., *The Effect of Mismatched Components on Microwave Noise-Temperature Calibrations*, Technical Report 32-1345, Jet Propulsion Laboratory, Pasadena, Calif., reprinted from *IEEE Trans. Microwave Theor. Tech.*, Vol. MTT-16, No. 9, pp. 675-686, Sept. 1968.
- Otoshi, T. Y., Stelzried, C. T., and Yates, B. C., "Comparisons of Waveguide Losses Calibrated by the DC Potentiometer, AC Ratio Transformer, and Reflectometer Techniques," *IEEE Trans. Microwave Theor. Tech.*, Vol. MTT-18, No. 7, pp. 406-409, July 1970.
- Otoshi, T. Y., and Stelzried, C. T., "A Precision Compact Rotary Vane Attenuator," *IEEE Trans. Micro. Theor. Technique*, Vol. MTT-19, No. 11, pp. 843-854, Nov. 1971.
- Otoshi, T. Y., "Precision Reflectivity Loss Measurements of Perforated-Plate Mesh Materials by a Waveguide Technique," *IEEE Trans. Instr. Meas.*, Vol. IM-21, No. 4, pp. 451-457, Nov. 1972.
- Pease, G. E., et al., *The Mariner V Flight Path and Its Determination From Tracking Data*, Technical Report 32-1363, Jet Propulsion Laboratory, Pasadena, Calif., July 1, 1969.
- Posner, E. C., *Properties of Error-Correcting Codes at Low Signal-to-Noise Ratios*, Technical Report 32-602, Jet Propulsion Laboratory, Pasadena, Calif., June 15, 1964.
- Potter, P. D., *The Design of a Very High Power, Very Low Noise Cassegrain Feed System for a Planetary Radar*, Technical Report 32-653, Jet Propulsion Laboratory, Pasadena, Calif., Aug. 24, 1964.
- Potter, P. D., Merrick, W. D., and Ludwig, A. C., *Large Antenna Apertures and Arrays for Deep Space Communications*, Technical Report 32-848, Jet Propulsion Laboratory, Pasadena, Calif., Nov. 1, 1965.
- Potter, P. D., *A Computer Program for Machine Design of Cassegrain Feed Systems*, Technical Report 32-1202, Jet Propulsion Laboratory, Pasadena, Calif., Dec. 15, 1967.
- Potter, P. D., et al., *A Study of Weather-Dependent Data Links for Deep Space Applications*, Technical Report 32-1392, Jet Propulsion Laboratory, Pasadena, Calif., Oct. 15, 1969.

- Preston, R. A., "Dual-Spacecraft Radio Metric Tracking," *The Deep Space Network: May and June 1974*, DSN Progress Report, pp. 51-65. Jet Propulsion Laboratory, Pasadena, Calif., Aug. 15, 1974.
- Rechtin, E., "Communication Techniques for Space Exploration," *IRE Trans. Space Electron. Telem.*, Vol. SET-5, No. 3, pp. 95-98, Sept. 1959.
- Rechtin, E., Stevens, R., and Victor, W. K., *Data Transmission and Communications*, Technical Release 34-55, Jet Propulsion Laboratory, Pasadena, Calif., Apr. 30, 1960.
- Rechtin, E., *Space Communications*, Technical Release 34-68, Jet Propulsion Laboratory, Pasadena, Calif., May 1, 1960.
- Rechtin, E., et al., *JPL Range and Doppler System*, Technical Memorandum 33-13, Jet Propulsion Laboratory, Pasadena, Calif., Sept. 22, 1961.
- Rechtin, E., Rule, B., and Stevens, R., *Large Ground Antennas*, Technical Report 32-213, Jet Propulsion Laboratory, Pasadena, Calif., Mar. 20, 1962.
- Rechtin, E., *Lunar Communications*, Technical Memorandum 33-133, Jet Propulsion Laboratory, Pasadena, Calif., June 28, 1963.
- Rechtin, E., "Surprises on Venus," *Int. Sci. Technol.*, No. 20, pp. 13-14, Aug. 1963.
- Rechtin, E., "Long Range Planning for the Deep Space Network," *Astronaut. Aeronaut.*, Vol. 6, No. 1, pp. 28-35, Jan. 1968.
- Reid, M. S., et al., "Low-Noise Microwave Receiving Systems in a Worldwide Network of Large Antennas," *Proc. IEEE*, Vol. 61, No. 9, pp. 1330-1335, Sept. 1973.
- Renzetti, N. A., et al., "Radio Tracking Techniques and Performance of the U.S. Deep Space Instrumentation Facility," *Space Research II, Proceedings of the Second International Space Science Symposium*, Florence, Italy, April 1961, North Holland Publishing Company, Amsterdam.
- Renzetti, N. A., and Ostermier, B. J., *Communications with Lunar Probes*, Technical Report 32-148, Jet Propulsion Laboratory, Pasadena, Calif., Aug. 23, 1961.
- Renzetti, N. A., "DSIF in the Ranger Project," *Astronautics*, Vol. 6, No. 1, pp. 34-37, 70, Sept. 1961.
- Renzetti, N. A., *Tracking and Data Acquisition for Ranger Missions I-V*, Technical Memorandum 33-174, Jet Propulsion Laboratory, Pasadena, Calif., July 1, 1964.
- Renzetti, N. A., *Tracking and Data Acquisition for Ranger Missions VI-IX*, Technical Memorandum 33-275, Jet Propulsion Laboratory, Pasadena, Calif., Sept. 15, 1966.
- Renzetti, N. A., *Tracking and Data Acquisition Support for the Mariner Venus 1962 Mission*, Technical Memorandum 33-212, Jet Propulsion Laboratory, Pasadena, Calif., July 1, 1965.
- Renzetti, N. A., *Tracking and Data Acquisition Report, Mariner Mars 1964 Mission: Near-Earth Trajectory Phase*, Technical Memorandum 33-239, Vol. I, Jet Propulsion Laboratory, Pasadena, Calif., Jan. 1, 1965.

- Renzetti, N. A., *Tracking and Data Acquisition Report, Mariner Mars 1964 Mission: Cruise to Post-Encounter Phase*, Technical Memorandum 33-239, Vol. II, Jet Propulsion Laboratory, Pasadena, Calif., Oct. 1, 1967.
- Renzetti, N. A., *Deep Space Network Support, Atlas/Centaur Missions 1-9*, Technical Memorandum 33-347, Jet Propulsion Laboratory, Pasadena, Calif., Sept. 15, 1967.
- Renzetti, N. A., "Tracking and Data Acquisition System for Mariner Missions," *Proceedings of the Seventh International Symposium on Space Technology and Science*, Tokyo, 1967.
- Renzetti, N. A., *Tracking and Data Acquisition Report, Mariner Mars 1964 Mission: Extended Mission*, Technical Memorandum 33-239, Vol. III, Jet Propulsion Laboratory, Pasadena, Calif., Dec. 1, 1968.
- Renzetti, N. A., and Fearey, J. P., "The Deep Space Network: An Instrument for the Radio Navigation for the Mariner Mission to Mars 1969," *IInd International Conference on Space Engineering*, Venice, Italy, D. Reidel Publishing Co., Dordrecht, Holland, May 1969.
- Renzetti, N. A., *Tracking and Data System Support for Surveyor: Missions I and II*, Technical Memorandum 33-301, Vol. I, Jet Propulsion Laboratory, Pasadena, Calif., July 15, 1969.
- Renzetti, N. A., *Tracking and Data System Support for Surveyor: Missions III and IV*, Technical Memorandum 33-301, Vol. II, Jet Propulsion Laboratory, Pasadena, Calif., Sept. 1, 1969.
- Renzetti, N. A., *Tracking and Data System Support for Surveyor: Mission V*, Technical Memorandum 33-301, Vol. III, Jet Propulsion Laboratory, Pasadena, Calif., Dec. 1, 1969.
- Renzetti, N. A., *Tracking and Data System Support for Surveyor: Mission VI*, Technical Memorandum 33-301, Vol. IV, Jet Propulsion Laboratory, Pasadena, Calif., Dec. 1, 1969.
- Renzetti, N. A., *Tracking and Data System Support for Surveyor: Mission VII*, Technical Memorandum 33-301, Vol. V, Jet Propulsion Laboratory, Pasadena, Calif., Dec. 1, 1969.
- Renzetti, N. A., *Tracking and Data System Support for the Mariner Venus 67 Mission: Planning Phase Through Midcourse Maneuver*, Technical Memorandum 33-385, Vol. I, Jet Propulsion Laboratory, Pasadena, Calif., Sept. 1, 1969.
- Renzetti, N. A., *Tracking and Data System Support for the Mariner Venus 67 Mission: Midcourse Maneuver Through End of Mission*, Technical Memorandum 33-385, Vol. II, Jet Propulsion Laboratory, Pasadena, Calif., Sept. 1, 1969.
- Renzetti, N. A., *Tracking and Data System Support for the Pioneer Project: Pioneer VI. Prelaunch to End of Nominal Mission*, Technical Memorandum 33-426, Vol. I, Jet Propulsion Laboratory, Pasadena, Calif., Feb. 1, 1970.
- Renzetti, N. A., *Tracking and Data System Support for the Pioneer Project: Pioneer VII. Prelaunch to End of Nominal Mission*, Technical Memorandum 33-426, Vol. II, Jet Propulsion Laboratory, Pasadena, Calif., Apr. 15, 1970.
- Renzetti, N. A., *Tracking and Data System Support for the Pioneer Project: Pioneer VIII. Prelaunch Through May 1968*, Technical Memorandum 33-426, Vol. III, Jet Propulsion Laboratory, Pasadena, Calif., July 15, 1970.

- Renzetti, N. A., *Tracking and Data System Support for the Pioneer Project: Pioneer IX. Prelaunch Through June 1969*, Technical Memorandum 33-426, Vol. IV, Jet Propulsion Laboratory, Pasadena, Calif., Nov. 15, 1970.
- Renzetti, N. A., *Tracking and Data System Support for the Pioneer Project: Pioneer VI. Extended Mission: July 1, 1966-July 1, 1969*, Technical Memorandum 33-426, Vol. V, Jet Propulsion Laboratory, Pasadena, Calif., Feb. 1, 1971.
- Renzetti, N. A., *Tracking and Data System Support for the Pioneer Project: Pioneer VII. Extended Mission: February 24, 1967-July 1, 1968*, Technical Memorandum 33-426, Vol. VI, Jet Propulsion Laboratory, Pasadena, Calif., Apr. 15, 1971.
- Renzetti, N. A., *Tracking and Data System Support for the Pioneer Project: Pioneer VII. Extended Mission: July 1, 1968-July 1, 1969*, Technical Memorandum 33-426, Vol. VII, Jet Propulsion Laboratory, Pasadena, Calif., Apr. 15, 1971.
- Renzetti, N. A., *Tracking and Data System Support for the Pioneer Project: Pioneer VIII. Extended Mission: June 1, 1968-July 1, 1969*, Technical Memorandum 33-426, Vol. VIII, Jet Propulsion Laboratory, Pasadena, Calif., May 1, 1971.
- Renzetti, N. A., *Tracking and Data System Support for the Pioneer Project: Pioneers VI-IX. Extended Missions: July 1, 1969-July 1, 1970*, Technical Memorandum 33-426, Vol. IX, Jet Propulsion Laboratory, Pasadena, Calif., Aug. 15, 1971.
- Renzetti, N. A., and Siegmeth, A. J., *Tracking and Data System Support for the Pioneer Project: Pioneers 6-9. Extended Missions: July 1, 1971-July 1, 1972*, Technical Memorandum 33-426, Vol. XI, Jet Propulsion Laboratory, Pasadena, Calif., May 1, 1973.
- Renzetti, N. A., et al., *Tracking and Data System Support for the Mariner Mars 1969 Mission: Planning Phase Through Midcourse Maneuver*, Technical Memorandum 33-474, Vol. I, Jet Propulsion Laboratory, Pasadena, Calif., May 15, 1971.
- Renzetti, N. A., et al., *Tracking and Data System Support for the Mariner Mars 1969 Mission: Midcourse Maneuver Through End of Nominal Mission*, Technical Memorandum 33-474, Vol. II, Jet Propulsion Laboratory, Pasadena, Calif., Sept. 1, 1971.
- Renzetti, N. A., Linnes, K. W., and Taylor, T. M., *Tracking and Data System Support for the Mariner Mars 1969 Mission: Extended Operations Mission*, Technical Memorandum 33-474, Vol. III, Jet Propulsion Laboratory, Pasadena, Calif., Sept. 15, 1971.
- Renzetti, N. A., *A History of the Deep Space Network: From Inception to January 1, 1969*, Technical Report 32-1533, Vol. I, Jet Propulsion Laboratory, Pasadena, Calif., Sept. 1, 1971.
- Renzetti, N. A., "Radio Communications at Planetary Distances," paper presented at the International Convention on Radio Communication, Rome and Bologna, Italy, Mar. 1974.
- Richter, H. L., Rehtin, E., and Walter, W. K., *National Ground-Based Surveillance Complex (U)*, Publication 146, Jet Propulsion Laboratory, Pasadena, Calif., Feb. 16, 1959 (Confidential).

- Rocci, S. A., "The 210-ft Parabolic Fully Steerable Tracking Antennas for a Deep Space Instrumentation Facility," in *Deep Space and Missile Tracking Antennas*, pp. 50-70, ASME, New York, 1966.
- Rusch, W. V. T., *Phase Error and Associated Cross-Polarization Effects in Cassegrainian-Fed Microwave Antennas*, Technical Report 32-610, Jet Propulsion Laboratory, Pasadena, Calif., May 30, 1965.
- Rusch, W. V. T., and Stelzried, C. T., *Observations of the Lunar Eclipse of December 19, 1964, at a Wavelength of 3.3 MM*, Technical Report 32-1097, Jet Propulsion Laboratory, Pasadena, Calif., reprinted from *Astrophys. J.*, Vol. 148, No. 1, pp. 255-259, Apr. 1967.
- Rusch, W. V. T., *Applications of Two-Dimensional Integral-Equation Theory to Reflector-Antenna Analysis*, Technical Memorandum 33-478, Jet Propulsion Laboratory, Pasadena, Calif., May 1, 1971.
- Rusch, W. V. T., "Double Aperture Blocking by Two Wavelength-Sized Feed-Support Struts," *Electron. Lett.*, Vol. 10, No. 15, pp. 296-297, July 25, 1974.
- Sanger, D. K., *Digital Demodulation with Data Subcarrier Tracking*, Technical Report 32-1314, Jet Propulsion Laboratory, Pasadena, Calif., Aug. 1, 1968.
- Siegmeth, A. J., Purdue, R. E., and Ryan, R. E., *Tracking and Data System Support for the Pioneer Project: Pioneers 6-9. Extended Missions: July 1, 1970-July 1, 1971*, Technical Memorandum 33-426, Vol. X, Jet Propulsion Laboratory, Pasadena, Calif., Aug. 15, 1972.
- Siegmeth, A. J., et al., *Tracking and Data System Support for the Pioneer Project: Pioneer 10—Prelaunch Planning Through Second Trajectory Correction December 4, 1969 to April 1, 1972*, Technical Memorandum 33-584, Vol. I, Jet Propulsion Laboratory, Pasadena, Calif., Apr. 1, 1973.
- Simon, M. K., "Nonlinear Analysis of an Absolute Value Type of an Early-Late Gate Bit Synchronizer," *IEEE Trans. Commun. Technol.*, Vol. COM-18, No. 5, pp. 589-596, Oct. 1970.
- Simon, M. K., "Optimization of the Performance of a Digital-Data-Transition Tracking Loop," *IEEE Trans. Commun. Technol.*, Vol. COM-18, No. 5, pp. 686-689, Oct. 1970.
- Simon, M. K., and Lindsey, W. C., "Data-Aided Carrier Tracking Loops," *IEEE Trans. Commun. Technol.*, Vol. COM-19, No. 2, pp. 157-168, Apr. 1971.
- Simon, M. K., "On the Selection of an Optimum Design Point for Phase-Coherent Receivers Employing Bandpass Limiters," *IEEE Trans. Commun.*, Vol. COM-20, No. 2, pp. 210-214, Apr. 1972.
- Simon, M. K., "On the Selection of a Sampling Filter Bandwidth for a Digital Data Detector," *IEEE Trans. Commun.*, Vol. COM-20, No. 3, pp. 438-441, June 1972.
- Simon, M. K., and Springett, J. C., "The Performance of a Noncoherent FSK Receiver Preceded by a Bandpass Limiter," *IEEE Trans. Commun.*, Vol. COM-20, No. 6, pp. 1128-1136, Dec. 1972.
- Simon, M. K., and Springett, J. C., *The Theory, Design, and Operation of the Suppressed Carrier Data-Aided Tracking Receiver*, Technical Report 32-1583, Jet Propulsion Laboratory, Pasadena, Calif., June 15, 1973.

- Simon, M. K., and Smith, J. G., "Hexagonal Multiple Phase-and-Amplitude-Shift-Keyed Signal Sets," *IEEE Trans. Commun.*, Vol. COM-21, No. 10, pp. 1108-1115, Oct. 1973.
- Simon, M. K., and Smith, J. G., "Carrier Synchronization and Detection of QASK Signal Sets," *IEEE Trans. Commun.*, Vol. COM-22, No. 2, pp. 98-106, Feb. 1974.
- Simon, M. K., *Data-Derived Symbol Synchronization of MASK and QASK Signals*, Technical Memorandum 33-720. Jet Propulsion Laboratory, Pasadena, Calif., Dec. 15, 1974.
- Sjogren, W. L., et al., *The Ranger V Flight Path and Its Determination From Tracking Data*, Technical Report 32-562, Jet Propulsion Laboratory, Pasadena, Calif., Dec. 6, 1963.
- Sjogren, W. L., et al., *The Ranger VI Flight Path and Its Determination From Tracking Data*, Technical Report 32-605, Jet Propulsion Laboratory, Pasadena, Calif., Dec. 15, 1964.
- Sjogren, W. L., *The Ranger III Flight Path and Its Determination From Tracking Data*, Technical Report 32-563, Jet Propulsion Laboratory, Pasadena, Calif., Sept. 15, 1965.
- Sjogren, W. L., et al., *Physical Constants as Determined From Radio Tracking of the Ranger Lunar Probes*, Technical Report 32-1057, Jet Propulsion Laboratory, Pasadena, Calif., Dec. 30, 1966.
- Sjogren, W. L., *Proceedings of the JPL Seminar on Uncertainties in the Lunar Ephemeris*, Technical Report 32-1247, Jet Propulsion Laboratory, Pasadena, Calif., May 1, 1968.
- Sjogren, W. L., "Lunar Gravity Estimate: Independent Confirmation," *J. Geophys. Res.*, Vol. 76, No. 29, Oct. 10, 1971.
- Sjogren, W. L., et al., "Lunar Gravity via Apollo 14 Doppler Radio Tracking," *Science*, Vol. 175, No. 4018, pp. 165-168, Jan. 14, 1972.
- Slobin, S. D., "Beam Switching Cassegrain Feed System and Its Applications to Microwave and Millimeterwave Radioastronomical Observations," *Rev. Sci. Instr.*, Vol. 41, No. 3, pp. 439-443, Mar. 1970.
- Spier, G. W., *Design and Implementation of Models for the Double Precision Trajectory Program (DPTRAJ)*, Technical Memorandum 33-451, Jet Propulsion Laboratory, Pasadena, Calif., Apr. 15, 1971.
- Springett, J. C., *Telemetry and Command Techniques for Planetary Spacecraft*, Technical Report 32-495, Jet Propulsion Laboratory, Pasadena, Calif., Jan. 15, 1965.
- Springett, J. C., and Simon, M. K., "An Analysis of the Phase Coherent-Incoherent Output of the Bandpass Limiter," *IEEE Trans. Commun. Technol.*, Vol. COM-19, No. 1, pp. 42-49, Feb. 1971.
- Stelzried, C. T., *Post-Amplifier Noise Temperature Contribution in a Low-Noise Receiving System*, Technical Report 32-446, Jet Propulsion Laboratory, Pasadena, Calif., Jan. 1964.
- Stelzried, C. T., Reid, M. S., and Petty, S. M., *A Precision DC-Potentiometer Microwave Insertion-Loss Test Set*, Technical Report 32-887, Jet Propulsion Laboratory, Pasadena, Calif., Mar. 15, 1966.

- Stelzried, C. T., Reid, M. S., and Nixon, D., *Precision Power Measurements of Spacecraft CW Signal With Microwave Noise Standards*, Technical Report 32-1066, Jet Propulsion Laboratory, Pasadena, Calif., Feb. 15, 1968.
- Stelzried, C. T., and Reid, M. S., *Precision Power Measurements of Spacecraft CW Signal Level With Microwave Noise Standards*, Technical Report 32-1070, Jet Propulsion Laboratory, Pasadena, Calif., reprinted from *IEEE Trans. Instrum. Measurement*, Vol. IM-15, No. 4, pp. 313-324, Dec. 1966.
- Stelzried, C. T., and Rusch, W. V. T., *Improved Determination of Atmospheric Opacity From Radio Astronomy Measurements*, Technical Report 32-1115, Jet Propulsion Laboratory, Pasadena, Calif., reprinted from *J. Geophys. Res.*, Vol. 72, No. 9, pp. 2445-2447, May 1, 1967.
- Stelzried, C. T., and Otschi, T. Y., "Radiometric Evaluation of Antenna-Feed Component Losses," *IEEE Trans. Instrum. Measurement*, Vol. IM-18, No. 3, pp. 172-183, Sept. 1969.
- Stelzried, C. T., "Precision Microwave Waveguide Loss Calibrations," *IEEE Trans. Instrum. Measurement*, Vol. IM-19, No. 1, pp. 23-25, Feb. 1970.
- Stelzried, C. T., *A Faraday Rotation Measurement of a 13-cm Signal in the Solar Corona*, Technical Report 32-1401, Jet Propulsion Laboratory, Pasadena, Calif., July 15, 1970.
- Stelzried, C. T., et al., "The Quasi-Stationary Coronal Magnetic Field and Electron Density as Determined From a Faraday Rotation Experiment," *Sol. Phys.*, Vol. 14, No. 2, pp. 440-456, Oct. 1970.
- Stelzried, C. T., "Operating Noise-Temperature Calibrations of Low-Noise Receiving Systems," *Microwave J.*, Vol. 14, No. 6, pp. 41-46, 48, June 1971.
- Stelzried, C. T., et al., "Transformation of Received Signal Polarization Angle to the Plane of the Ecliptic," *J. Space. Rock.*, Vol. 9, No. 2, pp. 69-70, Feb. 1972.
- Stevens, R., and Victor, W. K., *The Goldstone Station Communications and Tracking System for Project Echo*, Technical Report 32-59, Jet Propulsion Laboratory, Pasadena, Calif., Dec. 1, 1960.
- System Capabilities and Development Schedule of the Deep Space Instrumentation Facility 1963-1967*, Technical Memorandum 33-83, Jet Propulsion Laboratory, Pasadena, Calif., Mar. 2, 1962.
- Tardani, P. A., *Madrid Site Selection Report*, Technical Memorandum 33-149, Jet Propulsion Laboratory, Pasadena, Calif., July 17, 1963.
- Tausworthe, R. C., *A Precision Planetary Range-Tracking Radar*, Technical Report 32-779, Jet Propulsion Laboratory, Pasadena, Calif., reprinted from *IEEE Trans. Space Electron. Telem.*, Vol. SET-11, No. 2, pp. 78-85, June 1965.
- Tausworthe, R. C., *Theory and Practical Design of Phase-Locked Receivers*, Technical Report 32-819, Vol. I, Jet Propulsion Laboratory, Pasadena, Calif., Feb. 15, 1966.
- Tausworthe, R., *Cycle Slipping in Phase-Locked Loops*, Technical Report 32-1127, Jet Propulsion Laboratory, Pasadena, Calif., reprinted from *IEEE Trans. Commun. Technol.*, Vol. COM-15, No. 3, pp. 417-421, June 1967.
- Tausworthe, R. C., Easterling, M. F., and Spear, A. J., *A High-Rate Telemetry System for the Mariner Mars 1969 Mission*, Technical Report 32-1354, Jet Propulsion Laboratory, Pasadena, Calif., Apr. 1, 1969.

- Tausworthe, R. C., *DSS Subsystem Implementation by Time-Shared Computer*, Technical Memorandum 33-420, Jet Propulsion Laboratory, Pasadena, Calif., Oct. 1, 1969.
- Tausworthe, R. C., "Convergence of Oscillator Spectral Estimators for Counted-Frequency Measurements," *IEEE Trans. Commun.*, Vol. COM-20, No. 2, pp. 213-217, Apr. 1972.
- Tausworthe, R. C., "Simplified Formula for Mean-Slip Time of Phase-Locked Loops With Steady-State Phase Error," *IEEE Trans. Commun.*, Vol. COM-20, No. 3, pp. 331-337, June 1972.
- Tausworthe, R. C., and Crow, R. B., "Improvements in Deep-Space Tracking by Use of Third-Order Loops," *Proceedings of the 1972 International Telemetry Conference, Los Angeles, California, October 10-12, 1972*, pp. 577-583.
- Telecommunications Systems Design Techniques Handbook*, Technical Memorandum 33-571, edited by R. E. Edelson, Jet Propulsion Laboratory, Pasadena, Calif., July 15, 1972.
- Textor, G. P., Kelly, L. B., and Kelly, M., *Tracking and Data System Support for the Mariner Mars 1971 Mission: First Trajectory Correction Maneuver Through Orbit Insertion*, Technical Memorandum 33-523, Vol. II, Jet Propulsion Laboratory, Pasadena, Calif., June 15, 1972.
- Thornton, J. H., Jr., *The Surveyor I and Surveyor II Flight Paths and Their Determination From Tracking Data*, Technical Report 32-1285, Jet Propulsion Laboratory, Pasadena, Calif., Aug. 1, 1968.
- Timor, U., "Equivalence of Time-Multiplexed and Frequency-Multiplexed Signals in Digital Communications," *IEEE Trans. Commun.*, Vol. COM-20, No. 3, pp. 435-438, June 1972.
- Titsworth, R. C., and Welch, L. R., *Power Spectra of Signals Modulated by Random and Pseudorandom Sequences*, Technical Report 32-140, Jet Propulsion Laboratory, Pasadena, Calif., Oct. 10, 1961.
- Titsworth, R. C., *The Algebra of Periodic Sequences*, Technical Report 32-381, Jet Propulsion Laboratory, Pasadena, Calif., Jan. 7, 1963.
- Titsworth, R. C., *Correlation Properties of Cyclic Sequences*, Technical Report 32-388, Jet Propulsion Laboratory, Pasadena, Calif., July 1, 1963.
- Titsworth, R. C., *Optimal Ranging Codes*, Technical Report 32-411, Jet Propulsion Laboratory, Pasadena, Calif., Apr. 15, 1963.
- Titsworth, R. C., *Equivalence Classes of Periodic Sequences*, Technical Report 32-568, Jet Propulsion Laboratory, Pasadena, Calif., June 15, 1964, reprinted from *Ill. J. Math.*, Vol. 8, No. 2, June 1964.
- Titsworth, R. C., *The Role of Pseudorandom Codes in Communications*, Technical Memorandum 33-185, Jet Propulsion Laboratory, Pasadena, Calif., Aug. 3, 1964.
- "Tracking and Data Acquisition System for Mariner Missions," *Proceedings of the Seventh International Symposium on Space Technology and Science*, Tokyo, May 1967.
- Vegos, C. J., et al., *The Ranger IX Flight Path and Its Determination From Tracking Data*, Technical Report 32-767, Jet Propulsion Laboratory, Pasadena, Calif., Nov. 1, 1968.

- Victor, W. K., *Precision Frequency Control—A Communications Requirement of the Space Age*, External Publication 627, Jet Propulsion Laboratory, May 13, 1959.
- Victor, W. K., and Stevens, R., "The Role of the Jet Propulsion Laboratory in Project Echo," *IRE Trans.*, Vol. SET-7, pp. 20-29, Mar. 1961.
- Victor, W. K., Stevens, R., and Golomb, S. W., *Radar Exploration of Venus: Goldstone Observatory Report for March-May 1961*, Technical Report 32-132, Jet Propulsion Laboratory, Pasadena, Calif., Aug. 1, 1961.
- Victor, W. K., Titsworth, R. C., and Rehtin, E., *Telecommunication Aspects of a Manned Mars Mission*, Technical Report 32-501, Jet Propulsion Laboratory, Pasadena, Calif., Aug. 20, 1963.
- Viterbi, A. J., *Acquisition Range and Tracking Behavior of Phase-Locked Loops*, External Publication 673, Jet Propulsion Laboratory, Pasadena, Calif., July 14, 1959.
- Viterbi, A. J., *On Coded Phase-Coherent Communications*, Technical Report 32-25, Jet Propulsion Laboratory, Pasadena, Calif., Aug. 15, 1960.
- Viterbi, A. J., *Classification and Evaluation of Coherent Synchronous Sampled-Data Telemetry Systems*, Technical Report 32-123, Jet Propulsion Laboratory, Pasadena, Calif., June 15, 1961.
- Viterbi, A. J., *Phase-Locked Loop Dynamics in the Presence of Noise by Fokker-Planck Techniques*, Technical Report 32-427, Jet Propulsion Laboratory, Pasadena, Calif., Mar. 29, 1963; also reprinted in *IEEE Proc.*, Vol. 51, No. 12, pp. 1737-1753, Dec. 1963.
- Viterbi, A. J., *Orthogonal Tree Codes for Communication in the Presence of White Gaussian Noise*, Technical Report 32-1120, Jet Propulsion Laboratory, Pasadena, Calif., reprinted from *IEEE Trans. Commun. Technol.*, Vol. COM-15, No. 2, pp. 238-242, Apr. 1967.
- Weber, W. J., Ackerknecht, W. E., and Kollar, F. J., *Viking X-Band Telemetry Experiment Final Report*, Technical Memorandum 33-794, Jet Propulsion Laboratory, Pasadena, California, Sept. 1, 1976.
- Winn, F. B., "Selenographic Location of Surveyor VI," in *Surveyor VI Mission Report: Part II. Science Results*, Technical Report 32-1262, Jet Propulsion Laboratory, Pasadena, Calif., Jan. 10, 1968.
- Winn, F. B., "Post Landing Tracking Data Analysis," in *Surveyor VII Mission Report: Part II. Science Results*, Technical Report 32-1264, Jet Propulsion Laboratory, Pasadena, Calif., Mar. 15, 1968.
- Winn, F. B., "Surveyor Post-Touchdown Analysis of Tracking Data," in *Surveyor Project Final Report: Part II. Science Results*, Technical Report 32-1265, Jet Propulsion Laboratory, Pasadena, Calif., June 15, 1968.
- Winn, F. B., *Surveyor Posttouchdown Analyses of Tracking Data*, NASA SP-184, National Aeronautics and Space Administration, Washington, D.C., p. 369.
- Wollenhaupt, W. R., *Tracking System Data Analysis Report, Ranger 4 Final Report*, Technical Report 32-523, Jet Propulsion Laboratory, Pasadena, Calif., Mar. 1, 1964.

- Wollenhaupt, W. R., et al., *The Ranger VII Flight Path and Its Determination From Tracking Data*, Technical Report 32-694, Jet Propulsion Laboratory, Pasadena, Calif., Dec. 15, 1964.
- Wong, S. K., and Reinbold, S. J., "Earth-Moon Mass Ratio From Mariner 9 Radio Tracking Data," *Nature*, Vol. 241, No. 5385, pp. 111-112, Jan. 12, 1973.
- Woo, R., and Ishimaru, A., "Remote Sensing of the Turbulence Characteristics of a Planetary Atmosphere by Radio Occultation of a Space Probe," *Radio Sci.*, Vol. 8, No. 2, pp. 103-108, Feb. 1973.
- Woo, R., et al., *Effects of Turbulence in the Atmosphere of Venus on Pioneer Venus Radio-Phase I*, Technical Memorandum 33-644, Jet Propulsion Laboratory, Pasadena, Calif., June 30, 1973.
- Yuen, J. H., "A Double-Loop Tracking System," *IEEE Trans. Commun.*, Vol. COM-20, No. 6, pp. 1142-1150, Dec. 1972.
- Yuen, J. H., *A Practical Statistical Model for Telecommunications Performance Uncertainty*, Technical Memorandum 33-732, Jet Propulsion Laboratory, Pasadena, Calif., June 15, 1975.

APPENDIX

VIKING TRACKING AND DATA SYSTEM CHRONOLOGY OF EVENTS

March 1968	Langley Research Center began in-house technical and contractual studies of possible Mars 1973 Lander Mission.
August 1968	National Aeronautics and Space Administration funding authority initiated for work regarding Mars 1973 mission.
September 1968	Jet Propulsion Laboratory tasked to conduct Advanced Planetary Mission Technology Studies of Mars 1973 Mission.
September - October 1968	Science planning and proposed instrument reviews, industrial meetings, etc.
September 1968	Preliminary announcement of flight opportunity, Mars 1973 Lander Mission.
November 1968	Office of Space Science and Applications approval of Viking Program: Mars soft landing, 1973, dual launch, Titan/Centaur launch vehicle, modified Mariner orbiting craft.
December 1, 1968	Tracking and Data System Estimated Capabilities Document published (initial issue).
January 1969	Jet Propulsion Laboratory mission operations and Tracking and Data System briefings for potential Viking project participants.
February 8, 1969	Fiscal Year 1969 Project Approval Document signed by the National Aeronautics and Space Administration Administration.
February 10, 1969	Viking Project Plan submitted to National Aeronautics and Space Administration Headquarters by Langley Research Center. Draft Viking Orbiter baseline conceptual design completed by Jet Propulsion Laboratory team.
February 11, 1969	Science team selected for Viking instrument development and mission planning.
February 18, 1969	First Viking project management review held at Langley Research Center.

- March 1969 Management agreement signed between National Aeronautics and Space Administration Langley Research Center and Jet Propulsion Laboratory for Tracking and Data Acquisition support activities.
- March 31, 1969 Viking Orbiter System Manager: H.W. Norris; Deputy: K.S. Watkins; Spacecraft Manager: A.E. Wolfe - appointed.
- May 14, 1969 Preliminary Tracking and Data System Master Working Schedule completed (issued in Project Management Report in July 1969).
- May 29, 1969 Selection of Martin-Marietta Corp. as Viking Lander System and project integration contractor.
- July 1969 Collins Radio Company selected as prime contractor for 64-meter (210-ft) Deep Space Network antennas for Spain and Australia.
- July 8, 1969 Viking Telecommunications Working Subgroup established to assure Tracking and Data System to Viking telecommunications compatibility.
- July 14, 1969 Deep Space Network manager for Viking, D.J. Mudgway, appointed by Tracking and Data System Manager, N.A. Renzetti.
- July 15, 1969 Formal announcement of flight opportunity, Viking Mars 1973 mission.
- August 1969 Preliminary Data System Development Plan for overseas 64-meter antenna stations.
- August 14, 1969 Award of fixed-price contract to Collins Radio Company for fabrication, shipment, erection, and test of two 64-meter antennas on overseas sites.
- August 18-19, 1969 First meeting of Viking Management Council at Martin-Marietta, Denver, to review management interfaces and evaluate potential problems.
- September 13, 1969 National Aeronautics and Space Administration Lunar and Planetary Missions Board reviewed and endorsed Viking Project Mission as presently defined.

- October 1969 Analysis of launch-to-injection trajectory revealed need for thorough study of near-Earth tracking and data acquisition, with likely addition of down-range coverage.
- October 7-8, 1969 First Viking Project Quarterly Review held at Langley Research Center.
- October 20, 1969 Viking Lander System and Project Integration Contract with Martin-Marietta Corp. formally signed and awarded by the National Aeronautics and Space Administration.
- November 3, 1969 Collins Radio contractor personnel arrive on-site in Australia to begin preparation for work on 64-meter antenna.
- November 1969 Network Capabilities Planning Team for Viking Project established, to develop baseline configuration of supporting system elements and interfaces.
- December 1, 1969 Release of initial Network Interface Design Handbook for Viking.
- December 5, 1969 Viking science investigators selected by National Aeronautics and Space Administration administrator.
- January 1970 Authorization to Commonwealth of Australia Department of Supply for tasks related to 64-meter antenna station.
- January 13, 1970 Viking launch period slipped from 1973 to 1975 opportunity; Jet Propulsion Laboratory and Martin-Marietta efforts curtailed; schedules reorganized.
- March 1970 Viking - Tracking and Data System interfaces identified (preliminary Tracking and Data System Operations Plan Vol. 1).
- May 15, 1970 Viking '75 Project Specification (RS-3703001) signed and released.
- June 1970 Viking/Tracking and Data System interface control document structure modified, Viking Orbiter/Lander/Launch Vehicle/Tracking and Data System Integration Plan established.
- June 22, 1970 Site surveying and work begins, Madrid site, for 64-meter antenna.

July 1970 Authorization to U.S. Naval Facility, Robledo, for tasks supporting 64-meter antenna project.

July 1970 Viking Mission Study meeting.

July 23, 1970 Type II trajectories decided on for Viking flights.

August 24, 1970 Final Data System Development Plan for overseas 64-meter antenna stations.

September 1970 Deep Space Station 43 (64-meter antenna, Australia) concrete pedestal poured.

September 1, 1970 Preliminary near-Earth tracking analysis completed.

September 1, 1970 Estimated capabilities for Viking 1975 project released (rewritten from Viking 73 document).

September 24, 1970 Mission definition and preliminary landing site selection, signed and released.

October 5, 1970 Network Interface Design Handbook (update for 1975 mission) released.

November 1970 400-kW transmitters deleted from design of overseas 64-meter antenna stations, 100-kW transmitters planned (400-kW to remain at Station 14), owing to budget constraints.

January 1971 Pouring of concrete for Station 63 (64-meter antenna, Spain) begun.

February 1971 Network Implementation Schedule released.

March 1971 S-band channel assignments (Channels 9, 13, 16, 20) made for Viking.

March 15, 1971 Viking Project Plan (M75-131-0) signed and released.

June 1971 Viking Support Instrumentation Requirements Document approved by Project Office (approved by Office of Space Sciences 7/29/71, by Office of Tracking and Data Acquisition 4/18/72).

July 1971 System Development Laboratory at Jet Propulsion Laboratory (supplemental flight operations facility) completed; occupancy begun.

July 5, 1971	Office of Computing and Information Systems created at Jet Propulsion Laboratory (Manager: Aaron Finerman).
August 23-27, 1971	Initial Mission Design Review.
October 1, 1971	Network to Space Flight Operations Facility relations altered by National Aeronautics and Space Administration Headquarters directive.
October 15, 1971	Preliminary version of National Aeronautics and Space Administration Support Plan distributed for review.
November 1, 1971	Functional Specification for Viking released.
December 1971	Viking Control and Computing Center System formed.
January 31, 1972	G.N. Gianopoulos appointed Manager, Viking Mission Control and Computing Center System.
February 1972	National Aeronautics and Space Administration Support Plan revised to match new Tracking and Data System interfaces reorganization.
March 1972	Mission Control and Computing Center Support Plan (analogous to National Aeronautics and Space Administration Support Plan) prepared.
May 8, 1972	National Aeronautics and Space Administration Support Plan approved at Jet Propulsion Laboratory. Final approval at National Aeronautics and Space Administration Headquarters June 8, 1972.
July 1, 1972	Compatibility Test Area 21 ready to support Viking tests and training.
July 3, 1972	Jet Propulsion Laboratory acceptance of Australian 64-meter antenna from contractor.
August 1972	Network Support Plan for Viking released.
September - December 1972	Dual-carrier investigations and tests conducted at Station 13, Goldstone.
January 1973	Start of first compatibility testing of Orbiter, Lander, and Flight Operations System at Compatibility Test Area 21.

January 2, 1973	Jet Propulsion Laboratory acceptance of Spanish 64-m antenna, from contractor.
March 30, 1973	Australian 64-m antenna begins tracking operations.
July 15, 1973	Tracking and Data System inputs provided for Program Requirements Document.
July 31, 1973	Network Preparation Plan (final) released.
August 31, 1973	Transfer of Station 63, Spanish 64-m antenna, from Engineering to Operations.
September 1973	Support Instrumentation Requirements Document update released.
October 10, 1973	Resolution of longitude anomaly study and conclusion that Network commitment to 2-m longitude accuracy (one-sigma) is valid.
November 1, 1973	Network Operations Plan (final) completed.
November 1973	Initial Block IV receiver/exciter installed at Station 14 (first new Viking-support hardware).
November 15, 1973	Deep Space Network/Mission Control Center Interface Requirements Document updated.
November 1973	Network Operations Plan for Viking completed.
December 1973	Status Review of the Software for the Telemetry and Command Processor confirms that design is complete and coding underway.
January 1974	Implementation of Compatibility Test Area 21 begins.
February 1974	Reconfiguration of Compatibility Test Area is completed with the engineering version of the Block IV Receiver-Exciter. Development of test procedures for the radio-frequency compatibility tests begins.
April 1974	Compatibility Test Area 21 ready to support the first system integration tests with Mission Control Center. Draft of the NASA Support Plan awaiting final guidelines from Headquarters. Network Control System support for launch and cruise now

planned for 1 December 1974. Planetary support including recall capability with Intermediate Data Records planned for 1 February 1976.

June 1974

System integration tests with Compatibility Test Area 21 and Mission Control Center have been completed with six simultaneous data streams at all bit rates. Test Area 21 configured and calibrated and ready to support Viking radio-frequency compatibility tests. Telemetry and Command Processor software ready for transfer to the operations program library. National Aeronautics and Space Administration Support Plan still awaiting final guidelines from National Aeronautics and Space Administration Headquarters.

July 1974

Compatibility Test Area 21 now ready to support data system compatibility tests with Mission Control Center Radio-frequency compatibility tests with Viking Orbiter and Lander in progress. Critical Pioneer and Helios flight support is delaying Viking implementation at Station 14.

August 1974

All radio-frequency compatibility tests and data system compatibility tests using two Orbiters, and one Lander completed satisfactorily. NASA Support Plan guidelines received from NASA Headquarters.

September 1974

Revised and expanded version of Network Operations Plan approved for release. NASA Support Plan for Viking presented for Director's signature. Station 71 and Station 14 implementation continuing with some interference due to uncertainties in the Helios A launch date. Stations 43 and 63 high-power transmitter installations suffering delays due to construction of facilities.

October 1974

Helios A launch date uncertainties impacting Station 71 implementation. Reconfiguration of Station 14 for Viking has been delayed by support required for Mariner 10 second encounter and uncertainties in the Helios launch date. Block IV receiver-exciter for Stations 43 and 63 continuing on schedule. Considerable amount of transmitter electronics already shipped to Stations 43 and 63.

Viking pathfinder tests deleted and require new schedule for compatibility testing at Station 71. Viking reconfiguration at Station 14 completed on 15 October. Delays have been due to the support required for Mariner 10 second encounter and uncertainties in Helios A launch date.

November 1974

Block IV receiver-exciter for Station 71 installed and being tested. At all Deep Space Station sites, implementation for Viking being hampered by impact of flight support for Mariner 10 extended mission, Pioneers 10 and 11, and uncertainties in the Helios launch. Task team established to develop work plan for all Viking implementation.

December 1974

Helios A now launched and implementation of remaining Viking equipment has commenced. First system integration test with Mission Control Center completed on 16 December. Viking task team indicates heavy demand for station hours to accomplish remaining Viking work on schedule. Special Network status review for Viking Project Office held on 9 December.

January 1975

Block IV receiver-exciters for Stations 43 and 63 continue on schedule. High-power transmitter installation completed at Station 63. Contractor starts work on construction of facilities at Station 43. Second Viking status review held on 24 January 1975. Approved NASA Support Plan expected from Headquarters in November has not arrived. Integrated Network schedule has been developed and programmed for reproduction on the 1108

February 1975

Equipment problems at Station 71 caused failure of third System Integration Test. Radio-frequency compatibility tests with Lander 1 in progress. Four weeks delay announced in completion of high-power transmitter facilities at Station 63. Three-week delay announced in facilities construction at Station 43. Viking NASA Support Plan now approved and distributed. Block II Network Operations Control Center now operational to support Viking launch and cruise. Development of Intermediate Data Record capability for Block III Network Operations Control Center in progress.

March 1975

Third System Integration Test at Station 71 now completed. Radio-frequency compatibility tests with Lander 1 and Orbiter 1 completed. Block IV receiver-exciter for Stations 43 and 63 continue on schedule; expect installation during antenna downtime in May and June.

April 1975

Viking Project has participated in Intermediate Data Record reviews for the Network Control Center. Implications of requirement for additional second 26-meter subnet several months earlier than originally planned being evaluated. Stations 11 and 14 declared ready to support planetary verification tests.

May 1975

At Merritt Island Station all data system compatibility tests complete. Block IV receiver-exciter for Station 43 is on site, but station personnel are on strike. No apparent threat to launch readiness dates. Performance Verification Tests with Stations 11 and 14 run on 28 April with reruns scheduled for May 5. Data transfer portion of these tests satisfactory, but analog and digital playback were unsuccessful. At Station 71, all data system compatibility tests completed with no liens. Block IV receiver-exciter for Station 63 is on site; installation and checkout in progress at Stations 43 and 63.

June 1975

Station 43 has resumed operational support. Noise abatement on the antenna at Station 63 commenced on June 23. All System Integration Tests and Ground Data System Tests complete throughout the network. Operational testing nearing completion in the second 26-meter subnet. Network test and implementation schedule now in regular use. Corrective measures to improve performance of analog recording within the network in effect. Network launch readiness review for Viking scheduled for July 9.

July 1975

Merritt Island Station has completed all compatibility tests. Station is providing prelaunch support. Block IV receiver-exciter at Stations 43 and 63 installed and checkout continues. Antenna noise abatement at Station 43 expected to be completed by July 30.