

N7717167



PAGE 1

PRELIMINARY EVALUATION OF
FIBER COMPOSITE REINFORCEMENT
OF TRUCK FRAME RAILS

James R. Faddoul

ABSTRACT

An experimental program was conducted to determine if a graphite fiber/resin matrix composite could be used to effectively reinforce a standard steel truck frame rail. A preliminary design was made and it was determined that the reinforcement weight could be reduced by a factor of 10 when compared to a steel reinforcement. A section of a 1/3 scale reinforced rail was fabricated to demonstrate low cost manufacturing techniques. The scale rail section was then tested and increased stiffness was confirmed. No evidence of composite fatigue was found after 500,000 cycles to a fiber stress of 34,000 psi. The test specimen failed in bending in a static test at a load 50% greater than that predicted for a non-reinforced rail.

E-9044

SUMMARY

Recently, emphasis has been placed on the cost effective application of new materials to reduce the weight of all vehicles - both in the air and on the ground. Reducing the weight of vehicles results in better fuel economy. Thus, in many instances, more costly materials may be substituted for conventional materials because the initial higher cost will be more than offset by decreased fuel cost resulting from the reduced weight. As a class, fiber-reinforced composite materials offer the greatest potential for reducing vehicle weight. However, the cost of composites, especially the higher modulus types (graphite and boron reinforced) is relatively high and their effective application can only be achieved by using their unique properties of high strength and/or stiffness to the greatest advantage.

The subject of this report, a graphite/epoxy reinforced truck frame rail, is typical of an application that makes maximum use of the unique properties of an advanced composite. Since the major purpose of reinforcing a frame rail is to increase stiffness and provide for greater gross vehicle weight (GVW) capacity, a composite reinforced rail was designed to place high stiffness graphite in the areas where it could be used efficiently and in a cost-effective manner. This design resulted in a 10 to 1 reduction in the reinforcement weight. The work reported herein also demonstrated a low-cost manufacturing process.

To demonstrate the capability of the composite reinforced rail, 1/3 scale specimens were fabricated and tested. Due to fixturing problems, quantitative section modulus data were not obtained but a cyclic test did achieve over 500,000 cycles without evidence of composite degradation. The cycled specimen was then failed in bending in a static test at a load 50% greater than that calculated for an unreinforced rail section.

While the results of this program did substantiate the potential advantages of graphite composite reinforcement of a truck frame rail, there are a number of factors which have yet to be evaluated. Recommendations are therefore made to investigate environmental effects, ultimate load capability, effectiveness of the composite as a function of rail yield strength, and high stress (or strain) areas created by the application of the composite.

INTRODUCTION

During the last several years, structural composite materials have received increasing emphasis in government and industry aeronautics technology development programs. The objective has been to provide commercial and military aircraft with greater performance capabilities and simultaneously to increase the efficiency or reduce the fuel consumption of the aircraft fleet. Leadership in aircraft technology, a favorable balance of trade, maintenance of a continually improving technical capability for a strong national defense, and, more recently, a need to reduce consumption of petroleum products have been the stimuli for a number of aircraft composite programs. Materials technology development for aerospace applications has, however, been somewhat self-limiting in that improved performance generally has meant exotic and expensive materials in a limited use market. Consequently, the benefit/cost ratio of the technology has been marginal because the materials costs do not reflect the advantages that come from high volume production. The most direct way to improve this situation would be to find high volume industrial applications which will drive material production levels up substantially with resultant reduced per-unit costs. This is, however, a difficult task since the chief attributes of composite materials -- high stiffness and strength per unit weight -- may not be cost effective in many industrial applications where weight is not critical. Recent studies have thus concentrated on commercial application of advanced composites for systems which incorporate moving parts such as high speed rollers where reduced mass can mean increased machine speeds and productivity as well as on motor vehicles where reduced weight can mean increased payload and decreased fuel consumption. The productivity benefits can then be added to other composite materials benefits such as lower cost fabrication of complex shapes and part consolidation, and reduced machining, all with the aim of balancing the higher initial material cost.

Of primary interest at this time is the application of structural composites in motor vehicles (cars, busses, and trucks). Because of the large volume of motor vehicles produced each year, a relatively small component on each vehicle could mean a high demand for advanced fiber reinforcing material. For example, total aerospace and sporting goods consumption of graphite fibers is not expected to exceed two million pounds per year and the corresponding market price would be \$30 to \$35 per pound. A single pound of graphite in an individual automotive application could, however, result in a market demand for ten million additional pounds per year. The resulting material price would then be in the \$5 to \$10 per pound range.

Consequently, a number of automotive components were screened to evaluate their potential for cost effective structural composite design. Some of the factors considered were (1) potential for cost effective use of structural composite material; (2) high probability for effective use of advanced fibers (specifically graphite); (3) potential for near term entry into automobiles or trucks; (4) adaptability to low cost manufacturing processes; and (5) significance of component to consumption of composite materials. One component that rated reasonably high in all these categories was a reinforced truck frame rail and the results of a preliminary test and evaluation program conducted on a graphite fiber reinforced rail section are reported herein. The intent was to provide a preliminary verification that low cost fabrication methods could be used to apply a high modulus graphite composite to the upper and lower flanges of a steel channel. Accordingly, various reinforced and non-reinforced sections were tested for stiffness in bending, for fatigue, and for ultimate load capacity. Section sizes tested were approximately 1/3 scale but stress levels were maintained equivalent to those expected in full scale hardware.

FRAME RAIL DESIGN

While it would be possible to design an all-composite rail for a truck frame, the economics, including scheduling and stocking, at this time indicate that a better choice would be to use composites only as a replacement for the traditional steel reinforcing sections. Accordingly, an "L" reinforced steel channel, shown in Figure 1, was selected as the baseline metal design and the equivalent composite reinforced section is shown in Figure 2. The graphite composite thickness of 0.2 in. was determined on the basis of achieving a section modulus increase equivalent to that provided by the steel "L" reinforcement.

To calculate the section modulus of the reinforced section, the two components were broken into seven (7) elements as shown in Figure 3. The area moment of inertia of each element about the neutral axis was then calculated. The resulting moments of inertia were 44.91 in.⁴ and 65.57 in.⁴ for the "C" section and the reinforced "C" section respectively. Accordingly, the composite reinforcement was designed to provide a 50% (≈ 22 in.⁴) increase to the basic "C" section moment of inertia. The contribution of the composite resin system (matrix) to the overall moment of inertia was neglected because of the low Young's modulus and load carrying capability of matrix materials.

Since the graphite fibers can be supplied in a wide range of stiffnesses, the required thickness of the composite was calculated as a function of fiber modulus. A plot of this straight line relationship may be seen in Figure 4. The density of the graphite fibers is unaffected by modulus. Thus, the lightest weight reinforcement for a given stiffness increase would use the highest modulus (least thickness) graphite fibers. Material cost would, however, dictate the material selected since fiber price increases with modulus. For this design effort, a modulus of 50×10^6 psi was selected since it represents both a readily available fiber form and a minimum cost premium.

Table I lists all the significant design parameters for the unreinforced, steel reinforced, and composite reinforced "C" section. As can be seen from Table I, the result of this design effort was a composite reinforcement which weighed only 0.720 lb/ft as compared to the baseline steel reinforcement which weighed 8.08 lb/ft. This is more than a 90% reduction in reinforcement weight which results in a 35% reduction in reinforced section weight.

TEST SPECIMEN DESIGN AND FABRICATION

Specimen Design

A nominal 1/3 scale rail was selected as a test specimen in order to reduce the amount of graphite fiber and the size of the test apparatus required. The 1/3 scale is ideal in that it has "C" dimensions that are easily handled, provides a realistic composite width and thickness, and can be tested in machines with a 20,000 pound capacity.

The nominal dimensions of the channel were 3" X 1" and the final dimensions were accurately measured after fabrication. The area moment of inertia was calculated from these measurements and graphite reinforced composite caps were designed to provide a 75% increase in section modulus. This value was selected since it would be representative of both an "L" reinforcement and of a full "C" reinforcement. Specimen design was based on the use of a high modulus (50×10^6 psi) graphite. Final dimensions, moments of inertia and section moduli are listed in Table II.

Specimen Fabrication

One of the objectives of this program was to demonstrate that the composite could be applied to the channel with reasonable dimensional control using minimum cost tooling and material processing procedures. Thus, the fabrication technique selected was one which would use the thermal expansion of rubber in an inexpensive mold to permit pressure consolidation of the composite. In addition, a process which would cure the composite system and at the same time form the necessary holes and penetrations was established. The following describes the materials and fabrication procedures that were used to apply the graphite prepreg to both flanges of the channel.

Materials. - Moderate-to-low temperature curing materials were desired in order to minimize the amount of heating that would be required to fabricate the reinforced section. In addition, it was desirable to use a prepreg material to reduce the level of manpower and equipment necessary for fabrication. And, to insure a good bond between the composite and the steel, an intermediate adhesive with an open weave cloth (scrim) carrier to control bond line thickness was necessary. The final requirement was that all materials must be readily available since development or special orders of materials would be both too costly and too time consuming. The prepreg system most closely

approximating the requirements was the Hercules 1904/HMS prepreg and it was selected for the basic composite. The 1904/HMS is a single layer of collimated high modulus (50×10^6 psi) fibers in a prepregged epoxy resin that cures in 1 1/2 hours at 250 F. The fiber ultimate strength is in excess of 200,000 psi.

It should be noted that the required cure time for this specific prepreg system is too great for a production application but the composite system met all of the other material selection criteria. It is expected that for a production component, a resin would be selected and combined with the appropriate graphite fiber to provide a prepreg system uniquely tailored for the application. A number of such resins are available but could not be used in this program since they are not now incorporated in off-the-shelf graphite prepregs. It is anticipated that this would not represent a significant problem.

The adhesive selected was the Bloomingdale FM 53 modified epoxy which was compatible with both the resin system and cure of the 1904/HMS. FM 53 is supplied with a lightweight nylon scrim. To further simplify the fabrication process, no primer was used. The channel section was fabricated from mild steel having a yield strength of about 34,000 psi.

Process. - Specimen fabrication as described herein includes details of both the mold design which controls the fabrication process and the layup and cure procedures.

a) Mold Design - A schematic of the mold used for laminating the composite to the flanges of the channel can be seen in Figure 5. The basic molding process involved encasing the prepreg within silicone rubber faced steel plates so that differential thermal expansion during cure would provide enough pressure to consolidate the composite as the resin was warmed to the temperature at which it would flow. At the same time, pins driven through the prepreg layup prior to cure, provided for any necessary bolted attachments, pass throughs, or other penetrations without the need to drill or machine the composite subsequent to cure. In this way, no fibers were cut at the penetrations which could produce inherent weakness. Accordingly, four 1/8 in. diameter and two 1/4 in. diameter holes were molded into each flange. These hole sizes were proportional to those found in full size rail sections. Because material in the prepreg was displaced in the area of the holes, it was necessary to use a steel caul plate on top of the composite to restrict the fibers from pushing up and creating an irregular surface in the area where the hole forming pins reduced the cross

section. Ordinary C-clamps were used to hold the mold together for the cure. A "finger tight" clamping was required since the expansion of the silicone rubber provided the appropriate pressure for composite consolidation. A drawing of the molding equipment that might be used for full size rail reinforcement can be seen in Figure 6.

b) Layup and Cure Procedure - The 1904/HMS prepreg was supplied in a 12 in. wide roll. Accordingly, the material was sheared to length and then into 0.8 in. wide strips. Twenty one strips were then stacked and wrapped with a layer of glass fiber cloth. The glass cloth was found to be necessary to prevent slivering of the molded edges and possible injury to personnel during handling. One strip of FM 53 adhesive was also sheared to size for each flange. Having prepared the composite pack, the channel flanges were wire brushed with a rotary wheel and wiped with methyl ethyl ketone (MEK) prior to being placed in the mold. Appropriate application of a mold release agent was made and all pieces were then assembled into the mold as shown in Figure 5. The mold plates were clamped together and the resulting package was loaded into an oven preheated to 250°F. Although the nominal cure time for the resin is 1-1/2 hours at 250°F, the parts were allowed to remain in the oven for 2 to 2-1/2 hours to assure ample time-at-temperature for the heavily encased composite system. After cure, the parts were removed from the oven and allowed to cool to room temperature. C-clamps were then removed and the die plates and hole forming pins pulled away. The as-molded thickness of the composite averaged 6 mils per ply which is very close to what is achievable from the most tightly controlled molding processes. The final molded total thickness was 0.135 in. which included two layers of glass cloth and one layer of nylon scrim from the FM 53 adhesive. Thus, the desired thickness of graphite (0.122 in.) was effectively achieved. The desired composite width was 0.80 in. and a molded width of 0.813 in. was obtained. This simple molding technique thus proved to be highly effective in consolidating the composite and produced parts that were free of flash and required no post cure clean up operations.

TESTING

In order to demonstrate the increase in section modulus provided by the graphite composite, both a reinforced and a non-reinforced rail section were tested for static deflection. In addition, a fatigue test to demonstrate the ability of the composite to remain bonded and maintain structural integrity was conducted. Subsequent to the fatigue test a bending test was conducted to failure. Test procedures and results are discussed in the following sections.

Test Specimen Configuration

The assembly shown in Figure 7 was used to determine the deflection of the reinforced and non-reinforced rail section under load. By bolting two of the sections back to back as shown, it was possible to load the test assembly in three point bending with a 13 inch span and measure system deflections under relatively low loads. However, when the reinforced system was tested, it was found that the loads required to cause appreciable deflection were too great for a bolted system to maintain. Consequently, for the static test of the reinforced channels and for the cyclic test, the test assembly had the center load pad welded in place rather than bolted.

Static Test

The test assembly was placed in a compression testing machine with the outside load pads supported on rollers as shown in Figure 8. Dial indicators were then placed to measure deflection at the center load pad during the loading process. The load was increased in 500 pound increments and load and deflection measurements recorded until the maximum test load was achieved. The resulting load/deflection curve may be seen in Figure 9. The curve is approximately linear from 1000 to 7000 pounds load. The nonlinearity between 0 and 1000 pounds load is probably attributable to initial relative motion between the bolted load pads and the beam itself. Assuming that the total deflection of .041 in. could be reduced by the .014 in. of slip at the bolts, the remaining .027" deflection is still 3 times the amount which can be predicted by the standard beam equation, $Y=PL^3/48EI$. Even when the shear deflections are added, the deflection of both the reinforced and non-reinforced beams is more than can reasonably be accounted for. However, since all measurements were taken using the bed of the test machine as a reference, it was impossible to determine the amount of bolt slippage that might have occurred. Slipping of the

rails over the reaction load pads or the center load pad would cause an error in the measured deflection equal to the amount of slippage. It was believed that the main problem was in the center load pad and in a subsequent test of the reinforced beam, an attempt was made to correct the problem.

Because of the large deflections obtained with the unreinforced beam, the reinforced beam unit had the center load pad welded in place (see Figure 10). Otherwise the same procedure was followed and the load/deflection curve is shown in Figure 11. In this case, the initial non-linear deflection was reduced but the total deflection was still higher than the calculated value. It is believed, by the author, that the excess deflection was once again caused by the slippage of the load pads. (Only the center load pad had been welded while the reaction load pads were still bolted.) Consequently, the increased stiffness provided by the composite reinforcement cannot be quantified. It is, however, interesting to note that the slope of the load/deflection curve is approximately 78% less for the reinforced channels than for the unreinforced channel.

Fatigue Test

The same assembly, two rails bolted back-to-back, used for the static deflection test (with welded center load pad) was used for a cyclic load test in an MTS hydraulic closed loop controlled testing machine. The span of 13 inches and a maximum load of 7500 pounds produced an outer metal fiber stress calculated to be 34000 psi. This represents a stress level equal to the yield strength of the steel. The high stress was selected so that the test results would be conservative with respect to the stress level in the composite and the shear stress level in the bond joint. The fatigue test was conducted using an R ratio (minimum stress/maximum stress) of 0.066. The cyclic rate was 2.2 Hz.

After 250,000 cycles, it was noted that a fatigue crack was growing from a bolt hole for the center load pad (this was an open hole since the center pad was welded) in one of the rails. The crack was on the tensile side of the rail and extended from the hole towards the flange. No cracks were observed in the other rail. At 330,000 cycles, the crack had grown from the bolt hole through the metal part of the flange. The graphite composite, which was now carrying all of the flange load, appeared to be unaffected by the crack.

At 400,000 cycles, several cracks were noted in the other rail section. These cracks had not been noticed earlier since they were in the compression side of the web where rigorous inspection had not been made. The configuration of these cracks is shown in Figure 12.

At 450,000 cycles, the cracking had become so extensive that the test was terminated to reweld the center load pad. At this point, all the cracks were welded including the one in the flange underneath the graphite composite. Welding of the cracked flange severely overheated the composite, charred the resin, and destroyed the bond between the composite and the steel in the immediate vicinity of the weld. It was, however, decided to continue the test. An additional 80,000 cycles (530,000 total) were conducted at which point the cracking of the steel around the center load pad had again become very extensive. No evidence of composite deterioration could be found but the test was terminated because of inability to transfer load from the center load pad to the rail. The part was removed from the test machine and given a close visual inspection. The only defect in the reinforcement that could be found was an area of disbond of the composite from the metal in the area where the flange crack had been welded. The disbond extended for about 1" on each side of the crack. There was no additional degradation of the composite in the area that had been overheated by the weld. In every other area, the composite and bond appeared to be unaffected by the fatigue test.

Failure Load Test

After removing the test assembly from the fatigue test machine, the cracks in the webs and center load pad welds were again welded. The test assembly was then subjected to a 3 point bend-to-failure test. The test procedure was similar to that used for the load deflection test. The ultimate load carried by the test specimen was 12,700 pounds. Failure initiated due to buckling of one of the compression flanges and resulted in a load drop-off to 9000 pounds. Further attempts to load the test assembly resulted in failure of the tensile flange of the other rail section. The tensile failure was through the area where the flange was cracked and the composite had been charred by the weld repair procedure. This second failure resulted in another load drop which stabilized at 7000 pounds. The test was terminated at this point. A photograph of the buckled flange failure may be seen in Figure 13.

Although the failure load of 12,700 pounds was about 15% lower than the 15,000 pounds which is the calculated

buckling load for the composite reinforced beam or a channel with conventional full "C" reinforcement, the test specimen still withstood a load some 50% greater than would be expected for the ideal case of a non-reinforced beam. When related to the load history to which this specimen had been subjected, the ultimate load carrying capability was considered to be acceptable.

CONCLUSIONS

While this program did not quantify the increase in stiffness provided by the addition of graphite/epoxy caps to a model truck frame rail, the other objectives of demonstrating a low cost fabrication technique and adequate fatigue resistance of the composite were achieved. The following are the salient specific conclusions:

1. Graphite/resin caps can be applied to the flanges of a channel to increase the overall stiffness with an acceptable control of width and thickness and without the need for costly tooling.
2. Machining or drilling of holes and penetrations is not necessary since they can be molded into the composite during cure.
3. Fatigue failure of the composite or bond does not occur within 0.5×10^6 cycles at a stress level of 34,000 psi.
4. Application of graphite composite caps can increase the ideal buckling load capability of a steel channel by at least 50% even after 0.5×10^6 fatigue cycles.

RECOMMENDATIONS

While the composite stiffens the flanges, it adds no strength to the web and thus use of the composite reinforced channel at stress levels commensurate with its stiffness could shift the failure zone to the web in areas where holes and discontinuities exist. The cracking of the web which occurred during the fatigue test was evidence of this problem even though the stress level in the metal (flange stress equal to the yield strength) was significantly higher than would be experienced during normal use of a truck frame. Further testing to evaluate the effect of web stress level on cracking is recommended.

Resistance to salt water, temperature extremes, and long term weathering with salt, dirt, oil, etc., has not yet been demonstrated and, although it is not expected to be a problem, environmental degradation should be evaluated.

Compatibility with all grades of steel has not been demonstrated. However, even with a high strength steel, the operating stress of the composite is not expected to be greater than the 34,000 psi. which was demonstrated during the fatigue test and which is less than 20% of the ultimate capability of the fiber. However, for a composite reinforced rail fabricated from high yield strength steels, the increase in ultimate buckling load may not be proportional to the stiffness increase attributable to the composite. Testing with high strength steel rails is, therefore, suggested.

Other distortions to the state of stress in the beam (similar to the web cracking) may be a problem and should be investigated.

TABLE I. - FRAME RAIL DESIGN PARAMETERS

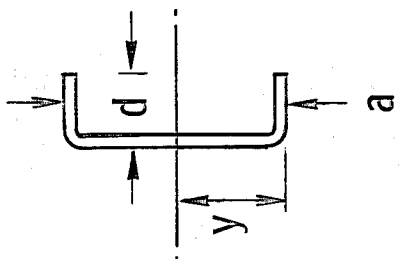
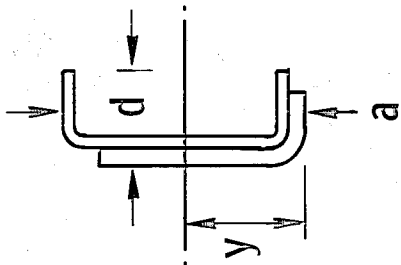
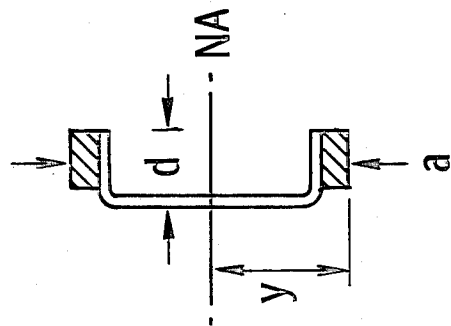

COMPOSITE
REINFORCED
CHANNEL

BASELINE
REINFORCED
CHANNEL

BASIC
CHANNEL

a (in.)	9.3	9.51	9.74
d (in.)	3.0	3.0	3.0
y (in.)	4.65	4.465	4.87
I_y (in ⁴)	44.91	69.31	69.88
I_y/y (in ³)	9.66	15.52	14.35
$I_y/(a - y)$ (in ³)	9.66	13.74	14.35
W_{TOTAL} (lb/ft)	13.14	21.22	13.93
$W_{REINFORCEMENT}$ (lb/ft)	-----	8.08	.792

TABLE II. - TEST SPECIMEN PARAMETERS

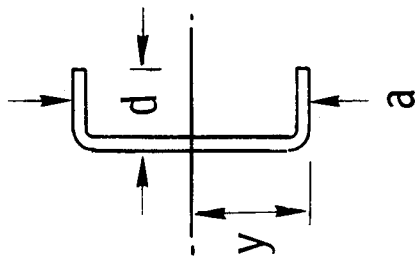
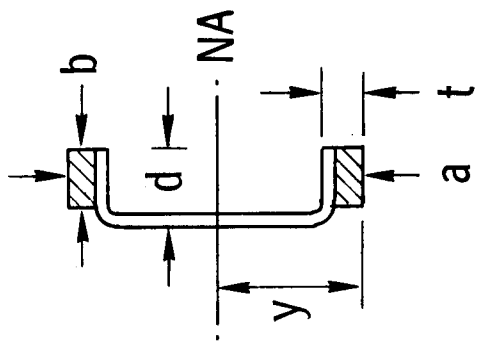

REINFORCED

BASELINE

a (in.)	3.18	3.42
d (in.)	1.0	1.0
y (in.)	1.59	1.71
b (in.)	----	.8
t (in.)	----	.122
I_y (in ⁴)	0.606	1.076
I_y/y (in ³)	.381	.629
W (lb/ft)	1.6	1.7

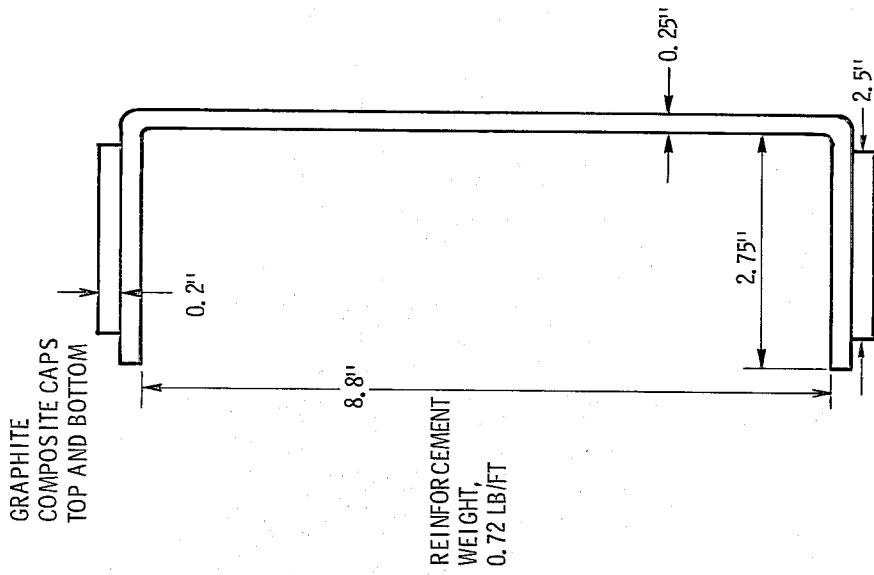

Figure 2. - Graphite composite reinforced rail section.

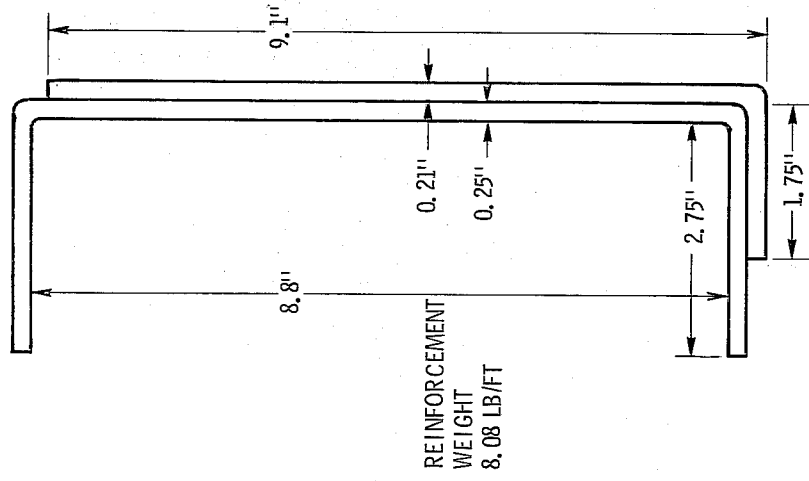
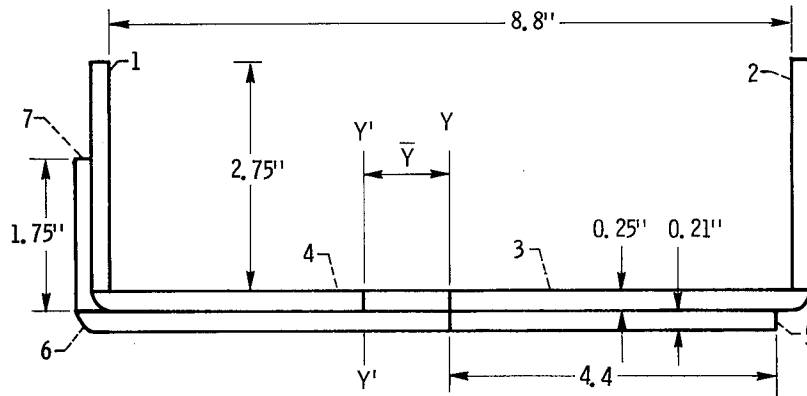

Figure 1. - Steel reinforced rail section.

17



ELEMENT NO.	AREA (in ²)	y (in)	Ay (in ³)	Ay ² (in ⁴)	y' (in)	Ay' ² (in ⁴)	I _C (in ⁴)
1	0.6875	-4.525	-3.111	14.077	-4.130	17.254	0.004
2	0.6875	4.525	3.111	14.077	4.920	24.206	.004
3	1.1625	2.325	2.703	6.284	2.720	7.418	2.095
4	1.1625	-2.325	-2.703	6.284	-1.930	3.725	2.095
5	0.8851	2.107	1.865	-----	2.502	6.260	1.310
6	1.0206	-2.430	-2.480	-----	-2.035	4.141	2.009
7	<u>0.3675</u>	<u>-4.755</u>	<u>-1.747</u>	-----	<u>-4.360</u>	<u>18.812</u>	<u>0.002</u>
Σ =	5.9732		-2.632	40.722		58.054	

$\bar{Y} = \Sigma Ay / \Sigma A = -0.395 \text{ in.}$

$I_{yy} \text{ (BASIC CHANNEL)} = \Sigma (Ay^2 + I_c) = 44.91.$

$I_{y'y'} \text{ (REINFORCED CHANNEL)} = \Sigma (Ay'^2 + I_c) = 65.57.$

Figure 3. - Moment of inertia data.

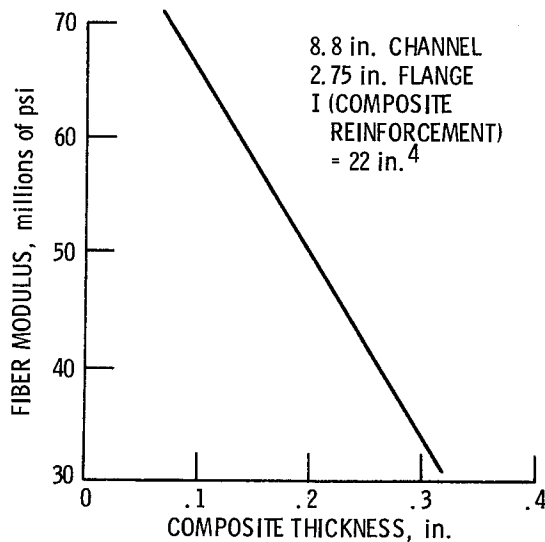

Figure 4. - Graphite composite thickness as a function of fiber modulus.

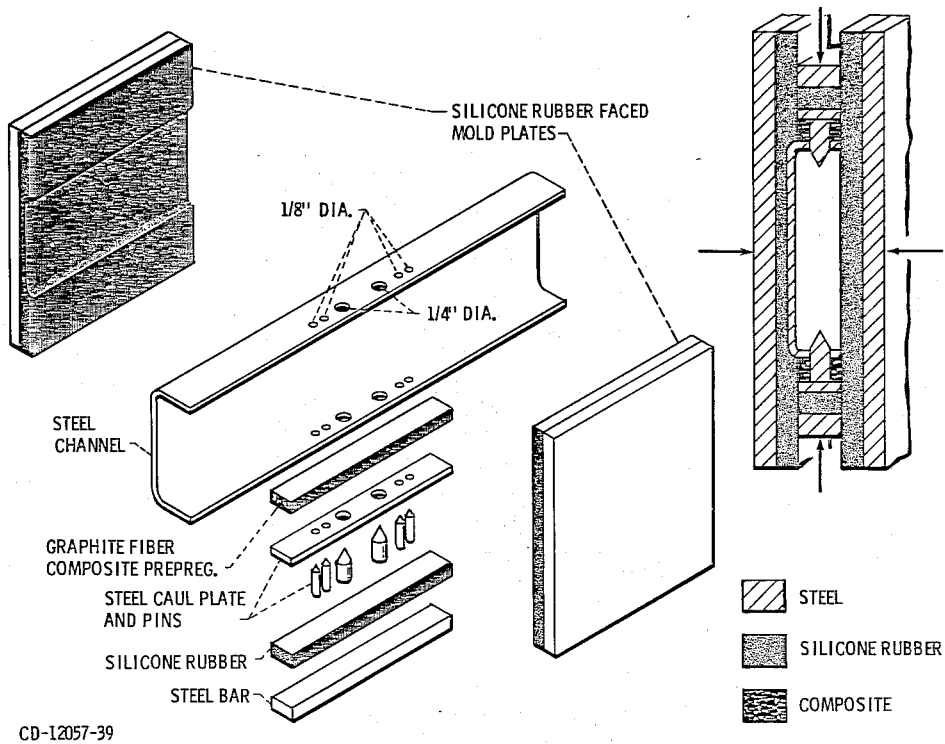

Figure 5. - Mold schematic.

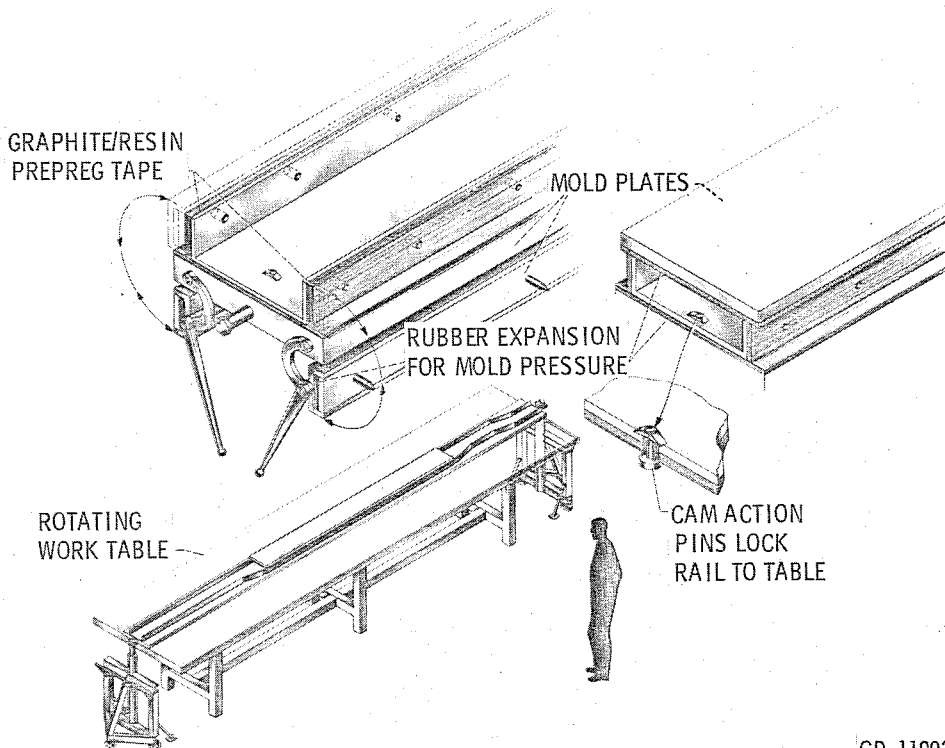

Figure 6. - Rail reinforcement manufacturing concept.

E-9044

19

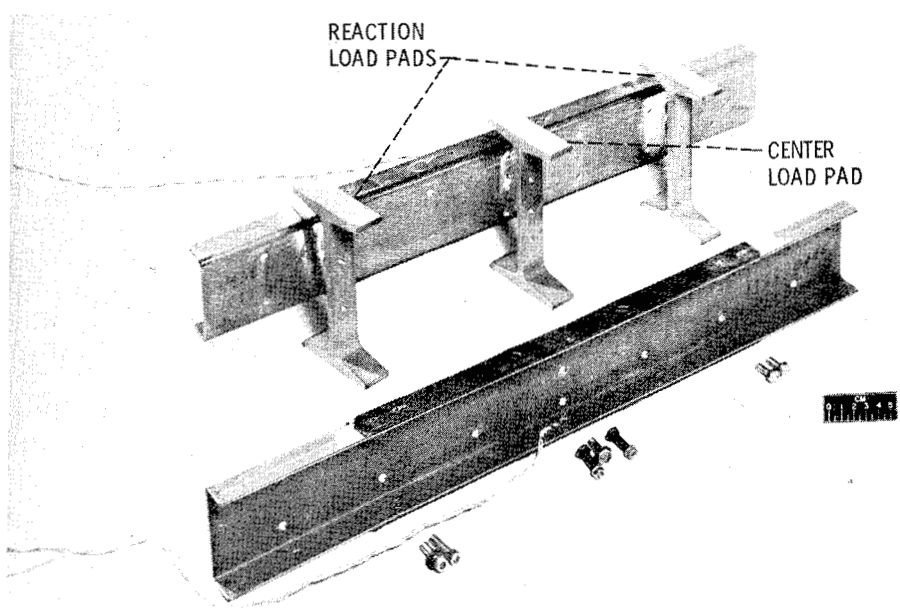

Figure 7. - Back-to-to-back rail test assembly.

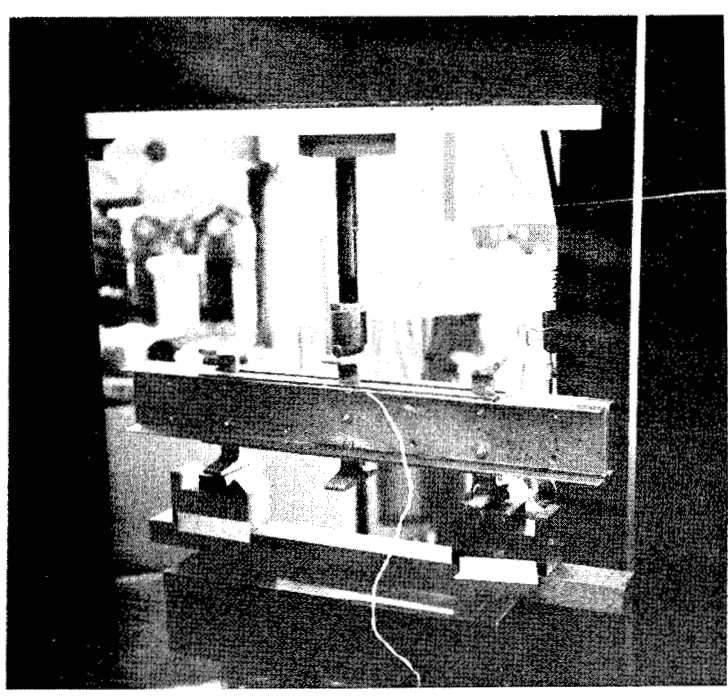

Figure 8. - Rail test assembly in testing machine.

20

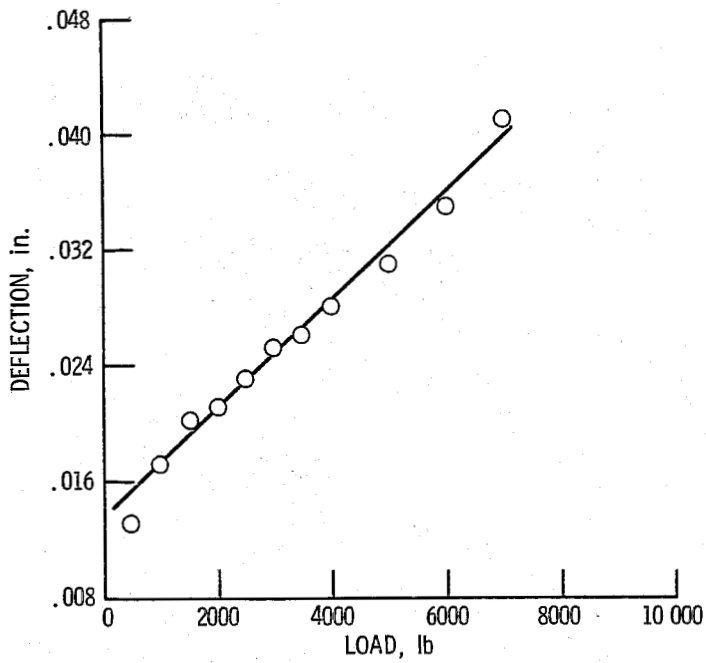

Figure 9. - Load deflection curve for nonreinforced beam assembly.

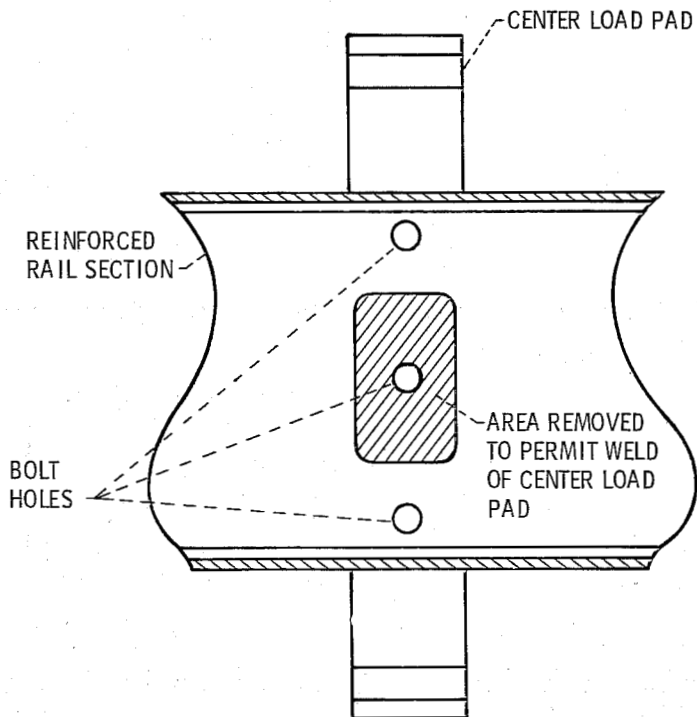

Figure 10. - Sketch of cutout for welding center load pad.

E-9044

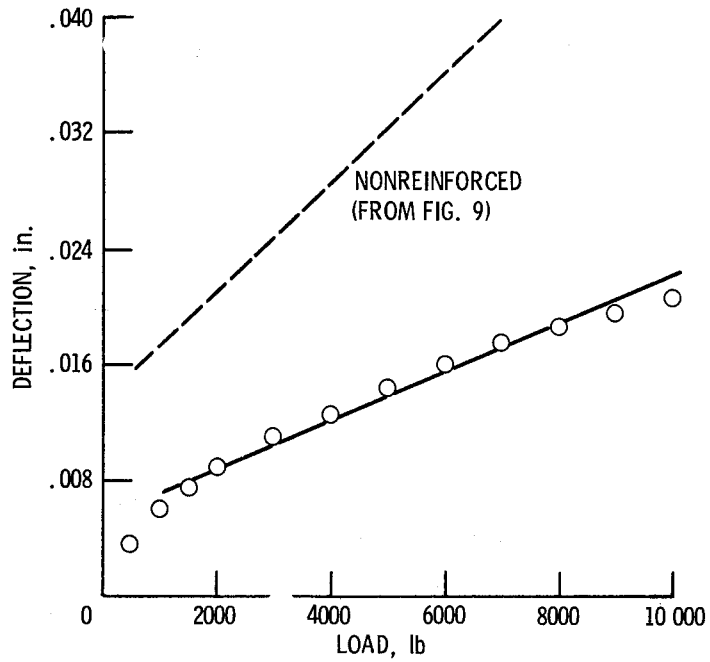

Figure 11. - Load deflection curve for reinforced beam assembly.

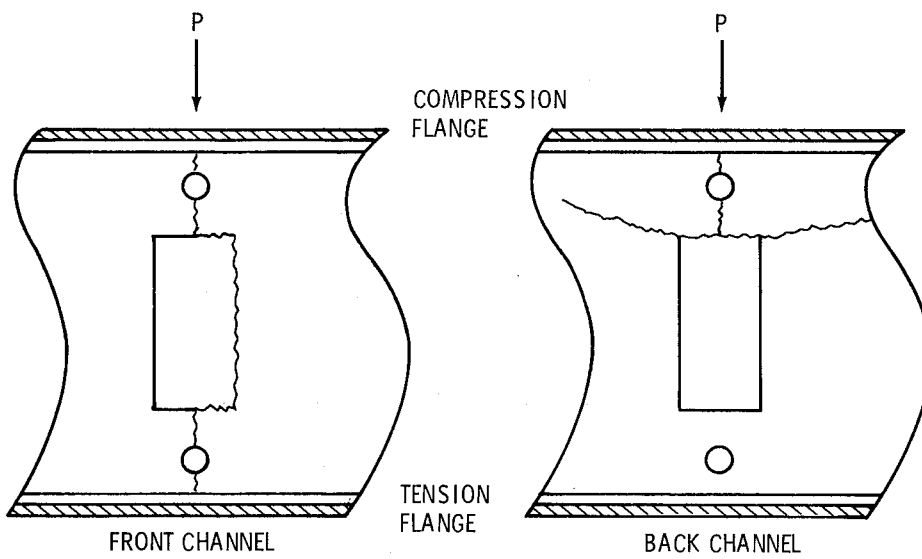

Figure 12. - Sketch of crack location and extent after 450,000 fatigue cycles.

ORIGINAL PAGE IS
OF POOR QUALITY

22

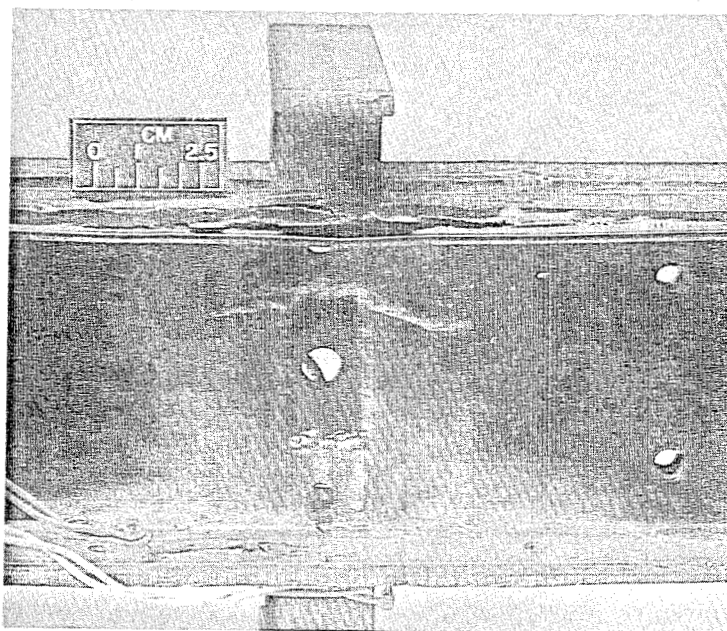

Figure 13. - Buckled flange after ultimate load failure.

