

Program Objectives

The Space Shuttle Program Objectives are twofold: 1) to reduce the cost of space operations, and 2) to provide a capability designed to support a wide range of scientific, applications, defense, commercial and international uses as mentioned earlier. This is to help establish a national space transportation capability (Figure 2). The Space Shuttle System as it is called is composed of 4 major parts. The Shuttle Orbiter (an aircraft-like structure), the large external hydrogen/oxygen tank, and the 2 rocket engines. The Orbiter is 122 feet (37.2 m) in length, and it has a wing span of 78 feet (23.8 m). In comparison to other known air or spacecraft, the Shuttle is slightly larger than the DC9. It is approximately 22 feet longer than the Boeing 737, half the height of the Saturn V (the rockets that took the Apollo crews to the moon).

Space Shuttle Mission Profile

Initially, the Shuttle will be launched from the Kennedy Space Center. Approximately 2 years later it is planned that the Western Test Range, located at Vandenberg Air Force Base, will be added as a launch site. The Shuttle Orbiter will be taken into near Earth orbit by the solid rocket engines which will be jettisoned and returned to Earth by a parachute system for reuse. The large external hydrogen/oxygen tank's propellants will continue to carry the Shuttle Orbiter into orbit and then the tank will be jettisoned. It will not be returned by parachute system and will not be reused. Mainly because of its large size and configuration, it will not be able to reenter the Earth's atmosphere without damage, so the crash point for the tank will be programmed for a remote place in one of the oceans. The orbiter will then remain in Earth orbit, nominally 100 to 200 miles from the Earth's surface. It will remain there from one week initially up to a maximum of 30 days during which time the various payloads will be activated, tested, exposed or launched. The cargo bay doors may be opened to allow for launch or to place spacecraft into orbit or, if there is a Spacelab attached within the cargo bay, it will remain and work will be performed in the Spacelab. After the mission is completed, the Orbiter will enter the Earth's atmosphere with a high angle of attack and will coast with the minimal assistance of non-airbreathing engines. It will coast in a preprogrammed flight plan and will land at Kennedy Space Center or Vandenberg Air Force Base. It is planned that there will be no more than a 2-week turnaround time between the time of landing and the next launch of a scheduled Shuttle mission (Figure 3) (1, 2).

Space Shuttle Program Activities

The Space Shuttle Program is made up of a number of planned activities. The development phase is now underway. Some of the key events are scheduled as follows: The first Space Shuttle Orbiter will be "brought out of the hangar" in the fall of 1976. The first captive flight test at Edwards Air Force Base is scheduled for the spring of 1977. Approach and landing tests also will be conducted at Edwards Air Force Base starting in the late summer of 1977. The first manned orbital test flights are scheduled for 1979. The operational flights then will begin early in the 1980s (Figure 4).

Space Shuttle Operations

The Space Shuttle is planned for a number of different operations. It will assist in orbital missions where we will have, for example, a telescope to permit astronomers to view heavenly bodies from above most of the Earth's atmosphere. The Shuttle Orbiter may also



1

serve as the propulsion stage for delivery and retrieval of orbiting spacecraft. It may replace the first two launch stages for a spacecraft that will be launched into deep space. It will also allow repair and servicing of satellites that are already in Earth orbit, thus providing an extension of the life of spacecraft in orbit. It will also permit the carrying of passengers and crewmembers to near Earth orbit for a space station when it is developed and becomes operational. In addition, rescue operations may be conducted if a crewmember were to become ill or when there is a problem in a spacecraft (Figure 5).

2) SPACELAB DESCRIPTION

The Spacelab actually may have 2 major parts - a pressurized volume and/or a pallet, carried separately or together (Figure 6). These are contained and carried into near Earth orbit in the cargo bay of the Shuttle Orbiter. The Spacelab remains attached in the cargo bay for the entire mission since it relies on the Shuttle Orbiter for many of the life support systems.

The Spacelab has been developed through international cooperation by the European Space Agency (ESA). ESA is made up of representatives from a number of European countries, with the major contributor, Germany, contributing over 53% of the financial backing. The United Kingdom, Italy and France are other large contributors, although nowhere near the percentage that Germany has contributed. ESA has its headquarters in Paris, and ESTEC (the space center which might be compared to the Johnson Space Center) is located in the Netherlands. This is where the Spacelab Program is managed. The major contractor working and coordinating the work of other contractors for Spacelab is ERNO, located in Bremen, Germany. It turns out that the nations contributing money into the program, to a large extent, have contractors receiving funds approximately equal to the amount that the country has contributed to ESA (Figure 7).

Experiment Accommodations of Spacelab (Pressurized Module)

The Spacelab will be in orbit initially 7 days, as I mentioned before, and it is planned that it may be extended to 30 days. The experiment weight that it will carry into orbit will be from 4600-16700 lbs. (2100-7600 kg). The experiment volume is 790 ft³ (22.3m³). The volume planned is for biological specimens. It cannot carry an elephant but could carry primates, man or his surrogates. The atmosphere is to be an Earth-like environment, i.e., 20% oxygen in nitrogen at 14.7 psi or 760 mmHg pressure. The temperature will be selectable and will be a shirtsleeve environment, 18-27°C. The utilities available are virtually those that can be expected in an Earth laboratory. There will be electrical power, thermal control, data processing as needed for tests currently considered. There will be support equipment, and storage, i.e., places to store film so that it can be used effectively, and there will be viewports to view the Earth or heavenly bodies from the pressurized volume of the Spacelab.

This has been a brief review of what the Spacelab is and plans to be to support scientific endeavors.

3) LIFE SCIENCES PROGRAM

Five main objectives are currently identified for the Life Sciences Program. The first is to explore and resolve the problems associated with future ventures of man in the exploration, exploitation, and eventual colonization of space. Next is to expand our knowledge of life sciences, i.e., life sciences as we perceive it to be related to Earth organisms. Another is to develop technology. This is something that we will be looking into. Coupled with this is an improvement in man's living conditions, both from an ecological and a biological standpoint. Lastly, prepare for space manufacturing and processing of biochemicals and biological materials. For instance, certain pharmaceuticals may be produced in space more effectively, purer, and less expensively than on Earth.

Life Sciences Program Overview

From the standpoint of presenting an overview of the Life Sciences Program, it can be divided into 3 segments. The first segment might be called the "Preparation Decade," i.e., from 1971 to 1981. The "Investigation Decade" would extend from 1981 to 1991, and beyond that, from 1991 to 2001, would be the "Exploitation Decade." During the preparation decade, i.e., from 1971 to 1981, you can further divide that into 2 parts. That part before 1974 had a number of programs that have led to the planning and developing of the Shuttle and the Spacelab. The Mercury, Gemini, Apollo and Skylab Programs all have certainly given us extensive information. There have been mission models and planning studies (which are actually payload definition studies) that have aided. The second part of this preparation decade can be identified as the "Development Period" and that is where we are right now. We are looking at the kinds of experiments which can benefit from the space environment and what support it will take to execute these experiments. Common Operational Research Equipment (CORE) is being investigated which will support the experiments and operational procedures. This will be described later. Some of the other activities that are taking place are the examination of carry-on laboratories. What can be done in the crew quarters of the Shuttle Orbiter in the way of experimentation in the very limited space that is available? What can be done in mini-labs when another discipline than life sciences is using the pressurized volume of the Spacelab? What can be done in mini-labs? What are those things that can be done life sciences-wise when the pressurized volume of the Spacelab is completely dedicated to life sciences? What are those experiments that can best fly on the proposed Biomedical Experiments Scientific Satellite (BESS)? These are the kinds of questions being considered now and will continue to be until the Shuttle/Spacelab becomes operational in the 1980s. Then the investigation decade will begin when operational flights will be available for life scientists to fly experiments. Probing type experiments and then in-depth experiments will naturally build on these for exploitation and building in breadth and depth of life sciences knowledge (Figure 8).

Space Transportation System Payload Program Elements

Not all individuals are aware of the various areas that can benefit from the space environment through the use of the Shuttle Spacelab. They range from Space Physics, Materials Sciences, Earth and Ocean Physics, Solar Physics, Astronomy, Earth Observations, Communications/Navigation, Technology, and High Energy Astrophysics, to Life Sciences. So many people do not appreciate that Life Sciences is not merely biomedical studies but ranges beyond biomedical studies to include areas such as the study of vertebrates, invertebrates,



plants, cells, tissues, bacteria and viruses, as well as environmental control and man/systems integration studies. These are areas of Life Sciences that we currently visualize that can benefit from studies in the space environment. There may be others.

Major Space Life Sciences Research Areas

The major Life Sciences research areas that are predicted to benefit from the space environment experimentation are Space Medicine, Clinical Medicine, Life Support Technology, and Space Biology. These are the 4 major categories that include areas in Life Sciences mentioned earlier (1, 2, 3, 4, 5).

Space Medicine.- In Space Medicine to date the general conclusion is that man can adapt to weightlessness with good health for extended periods of time with appropriate exercise, sleep, diet, working, and recreation. So far, no major physiological problems have been encountered, but we do need to understand and we do need experiments which will permit investigation of the mechanisms of changes that are occurring. Some remedial or preventive measures may be required for missions longer than the experience of 84 days that we had man in a weightless condition up to now. For voyages of man to Mars or other regions in space where he will be in the weightless condition as long as 9-12 months or perhaps several years, we certainly must look at longer term remedial or preventive measures.

Shuttle research emphasis in space medicine will probably focus on the vestibular, cardiovascular, mineral/fluid balance/electrolytes, and hematology areas, i.e., from the perspective of our experience on Skylab and the other manned programs.

Clinical Medicine.- In Clinical Medicine, the effects on physical condition will be studied. We must be prepared to treat fractures that might occur in a space environment and learn how healing will progress. We will examine wound healing, burn therapy, cardiovascular disease and therapy, and emergency and dental therapy. These are all conditions that are to be expected in individuals who will be in space. They are to be expected in individuals on Earth, and if man is going to be in space for extended periods, we must know how to handle these kinds of problems. In addition, there will be opportunities for new research in areas where we may have ailments of vision, muscle or cardiovascular function.

Life Support Technology.- In Life Support Technology, biological research involving both the crew and passengers as well as biological specimens will be examined. Regenerative life support systems involving atmospheric revitalization, reusing water that will be there in the spacecraft as a by-product and looking at sources of food that should be grown will demand attention.

Space Biology.- In Space Biology, vertebrates, invertebrates, cells and tissues and plants will be studied in the weightless context and radiobiologically. Again, this is a projection from past research efforts that have not been directed into an organized space research program.

NASA-Shuttle/Spacelab/Life Sciences Laboratory Traffic Model

The NASA-Shuttle Spacelab Traffic Model, or actually the projected plan of opportunities to fly in space during the decade of the 1980s, from the perspective of today, is quite encouraging. It is planned that approximately 10% of all the Shuttle flights will be flights

5) DEVELOPMENT OF PROGRAM PLANNING AND OPERATIONAL APPROACHES

An examination of the phases of a Life Sciences Payloads Mission would show it can be divided into 4 major segments or phases: Experiment Selection Phase, Preparation Phase, Flight Operations Phase, and Postflight Phase. Each of these can be further subdivided and then examined. In the Experiment Selection Phase, formulation of an overall plan takes place; solicitation, receiving of proposals, and selection takes place. In the Preparation Phase, mission scheduling, experiment development, experiment testing and training, and integrated simulations are some of the major areas. In the Flight Operations Phase, at prelaunch there is checkout, mating of the experiment carrier with the Orbiter, launch, flight operations, flight support, as well as landing operations. The Postflight Phase is composed of debriefing, examination of the data and distribution of the data and samples to the investigators for analysis and reporting by the experimenter. This is an example in a generalized way of what takes place in all flights. It is presented to give a concept of those things that must be considered for space flight.

Spacelab Mission Simulation

Some of the aspects of the mission have been investigated and reviewed through a Spacelab Mission Simulation. The current simulation plan at JSC projects a total of 5 Spacelab Mission Simulations or SMS. Two simulations have been conducted, 3 more are to occur, planned before the operational period of the Shuttle beginning in 1980 or 1981. Each one of the scheduled simulations will look at and emphasize specific aspects of operational planning. Totally, we will be considering science community involvement, management systems, experiment and payload processing, mission operation systems and approaches, equipment and facilities, supporting documentation, and Spacelab configurations as well as roles of organizations and key personnel.

Involvement of Non-NASA Scientists

The simulation that we are preparing for now will involve visiting scientists, those from organizations other than at the Johnson Space Center and other elements of NASA. The Spacelab Mission Simulation Program is considered key in preparing for the operational period that will soon be upon us.

Through an Invitation to Participate in Life Sciences Space Program Planning, an announcement of planning opportunity was issued in the spring of 1975. The announcement was sent to over 27,000 scientists in this country. As of early this year, over 1,400 responses with over 2,500 ideas for experiments were received. The responses are being used by NASA to determine the range and types of biological specimens that will be required. The data will be used for determining the scientific disciplines (specialties) that we must accommodate in the Shuttle, and to determine and identify the laboratory equipment that will be required. An Announcement of Flight Opportunity will be issued later in 1976. The first call will be for the first US/European Space Agency Spacelab flight scheduled for 1981. Although experiments will be somewhat limited for this Spacelab flight, later a general announcement of flight opportunity will be made for Life Sciences (6,7).

6) SUMMARY

In summary, it can be said that the Space Transportation System Program is well under way and will provide a broad new capability by the 1980s; a capability which will permit flying many Life Sciences experiments. The development of the Spacelab/Common Operational Research Equipment and the Biological Specimen Holding Facility will allow for the involvement of many scientists with minimum hardware costs. There will be a broad Life Sciences Program which is currently in the conceptual phase (some few ideas are now represented by preliminary designs). Perhaps the most important point is that for the diverse program to be a success the participation of life scientists such as you is required.



REFERENCES

1. Mason, J. A.; and Heberlig, J. C.: The Space Shuttle and Its Support for Space Bioresearch. *BioScience*, vol. 23(5), 1973, pp. 307-310.
2. Mason, J. A.: Opportunities for Biological Research in Space During the 1980's. *BioScience*, vol. 26(5), 1976, pp. 325-329.
3. National Academy of Sciences, Space Science Board: *Scientific Uses of the Space Shuttle*. 1974. Washington, D. C.
4. Winter, D. L.: Man in Space-A Time for Perspective: Crew Performance on Space Shuttle-Spacelab Program. *Astronautics and Aeronautics*, vol. 13(10), 1975, pp. 28-36.
5. National Aeronautics and Space Administration, Life Sciences: Final Report of the Space Shuttle Payload Planning Working Groups. U.S. Government Printing Office Document 1972-735-969-740, vol. 4, 1973, Washington, D. C.
6. National Aeronautics and Space Administration: An Invitation to Participate in Planning the NASA Life Sciences Program in Space. U. S. Government Printing Office Document 1975-628-637-268, 1975a, Washington, D. C.
7. Leeper, E. M.: NASA Seeks Help for Biologists. *BioScience*, vol. 25(4), 1975, p. 284.

TRENDS OF THE 1980'S - INTEGRATED SPACE OPERATIONS

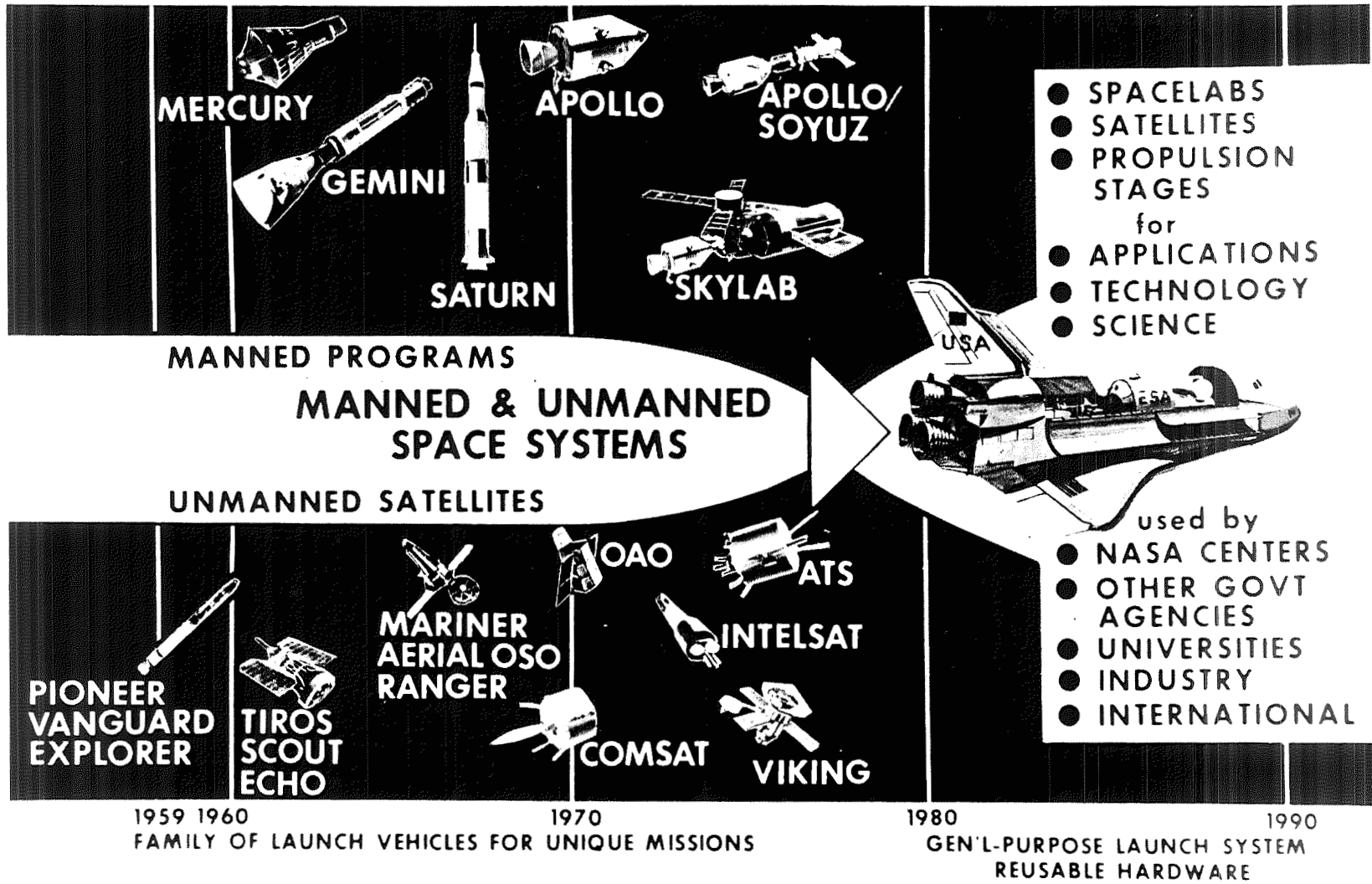

41

Figure 1.- Space Shuttle era (NASA-S-74-5358A).

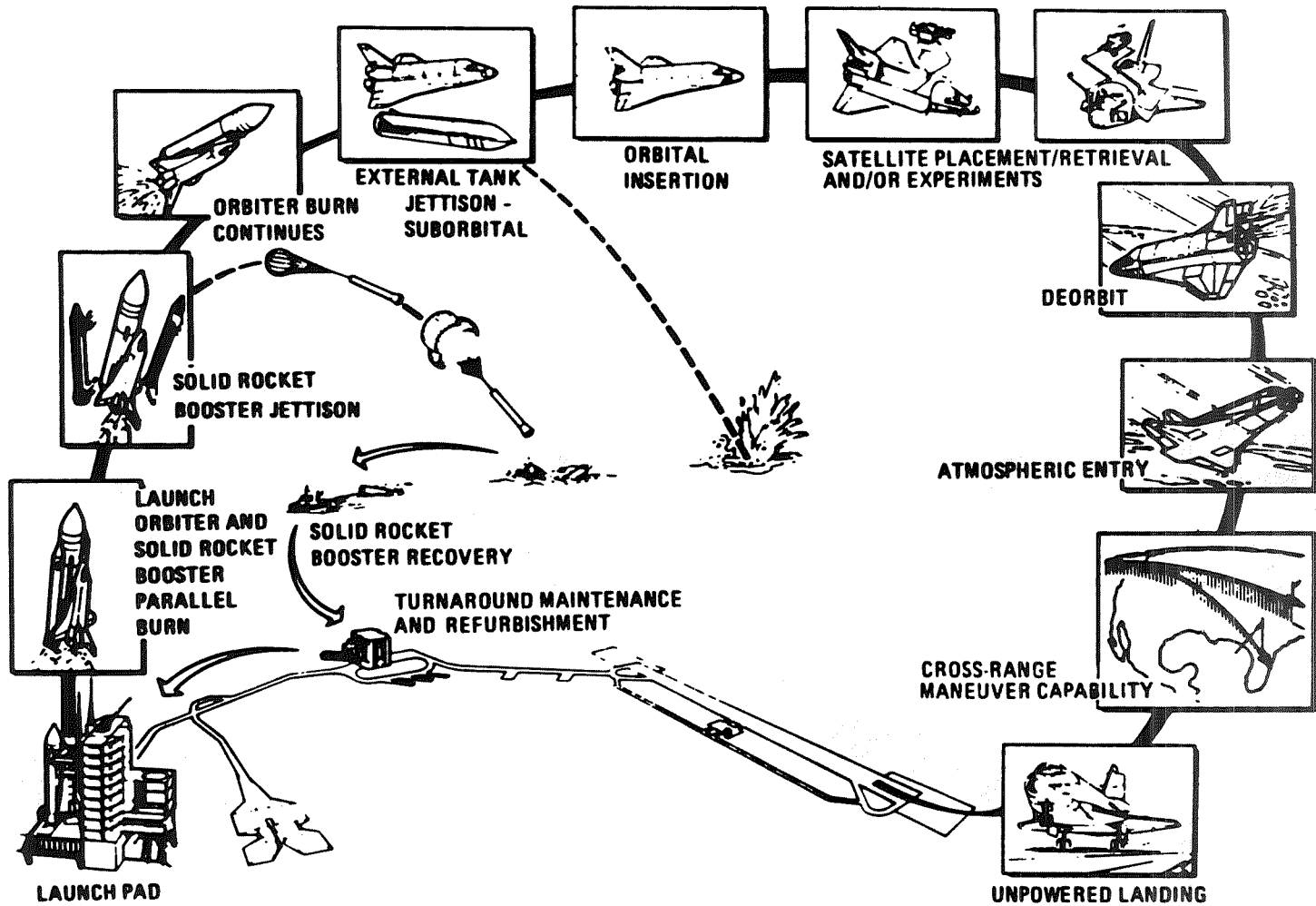

16

Figure 3.- Space Shuttle mission profile (NASA-S-75-868).

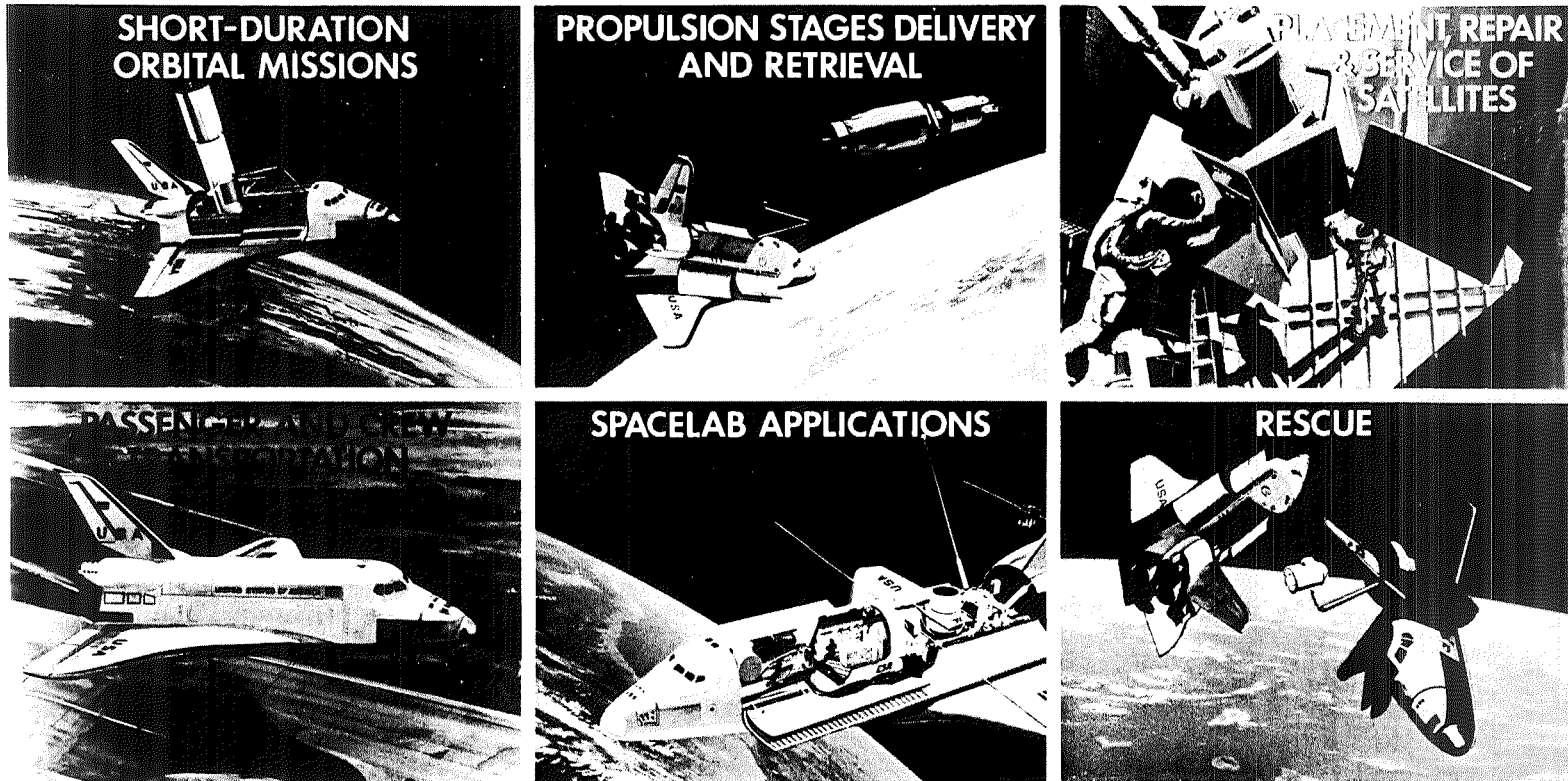

Figure 5.- Space Shuttle operations (NASA-S-73-2380B).

SPACE SHUTTLE
 SPACELAB 
 EUROPEAN SPACE AGENCY (ESA)

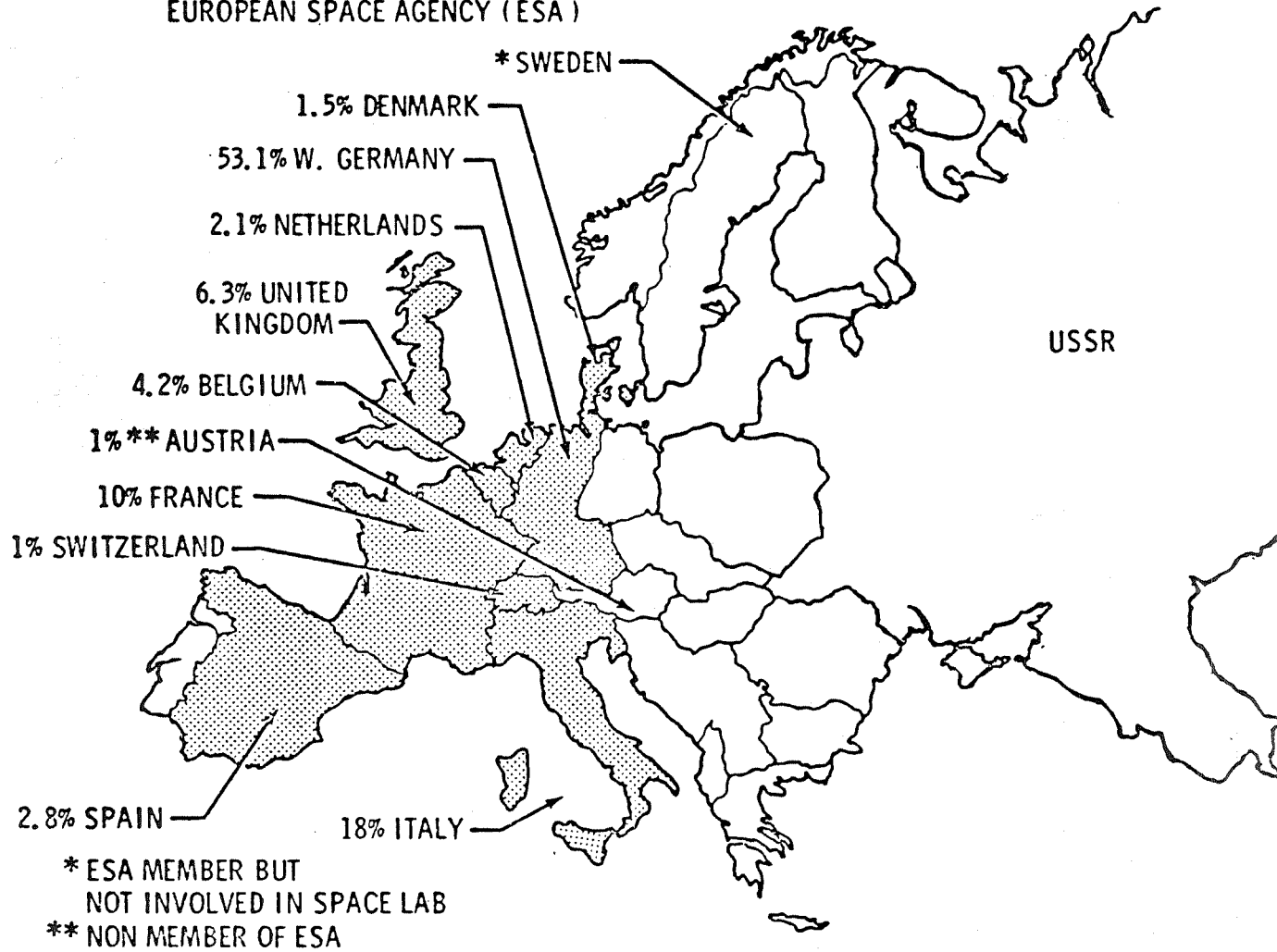

Figure 7.- Extent of international cooperation in manned space flight (NASA-S-74-3431C).

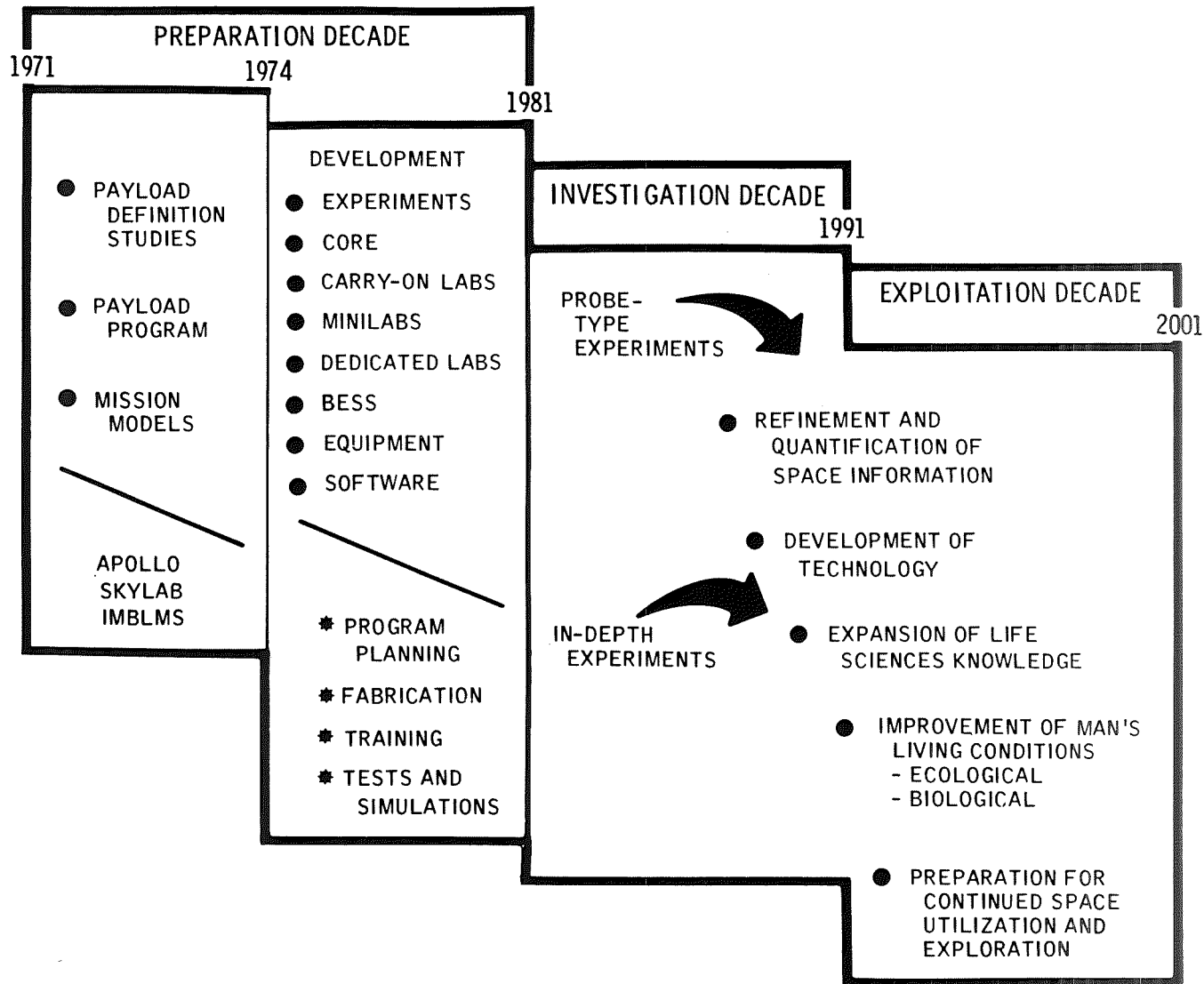
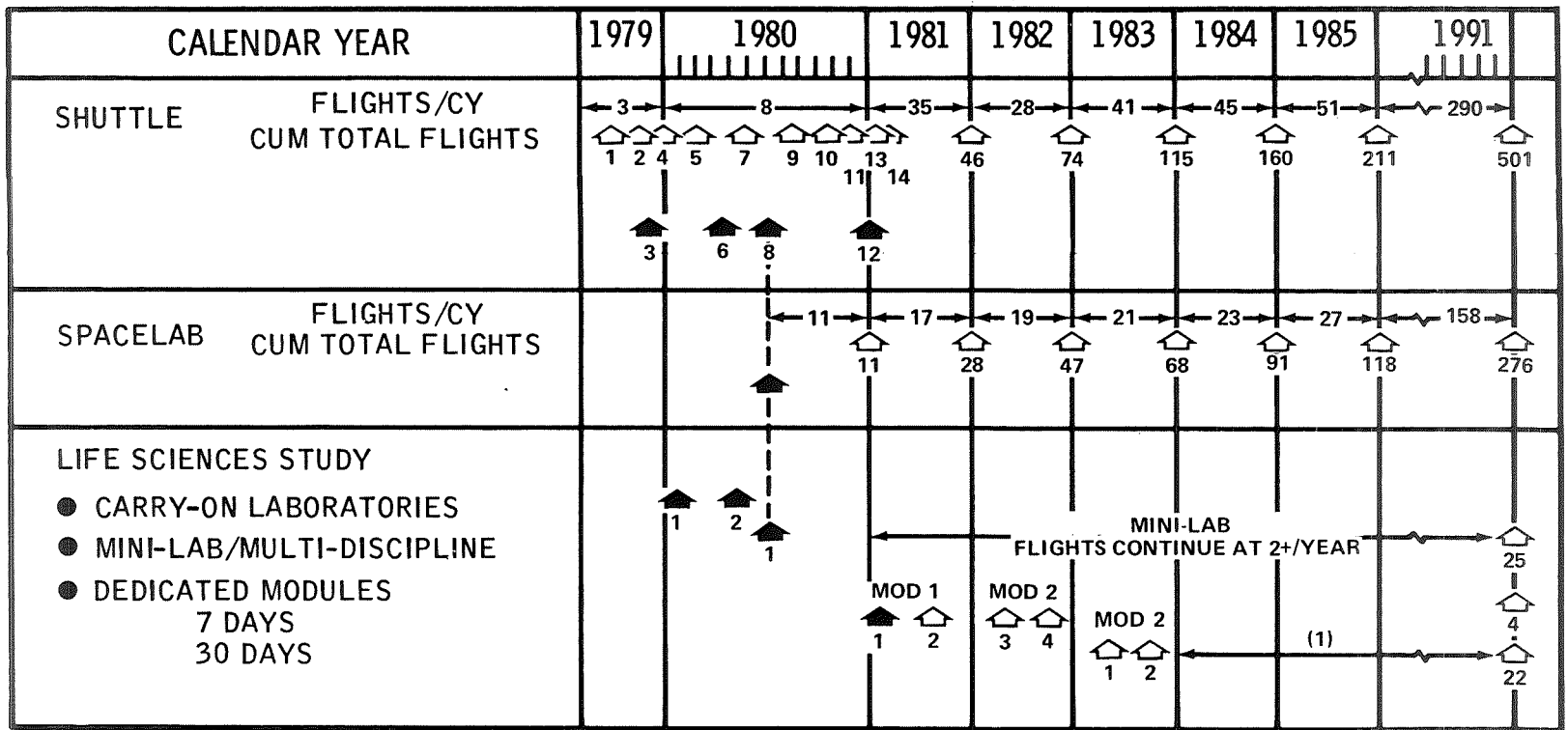

Figure 8.- Life science program overview (NASA-S-76-10159A).



(1) FLIGHTS CONTINUE AT 2/YEAR THRU 1987.
THEN 3/YEAR THRU 1991 FOR A TOTAL OF
26 LSL DEDICATED SPACELAB MISSIONS
(4;7 DAY AND 22;30 DAY)

Figure 9.- Space Shuttle/Spacelab/Life Sciences Laboratory (LSL) traffic model (NASA-S-76-10161).

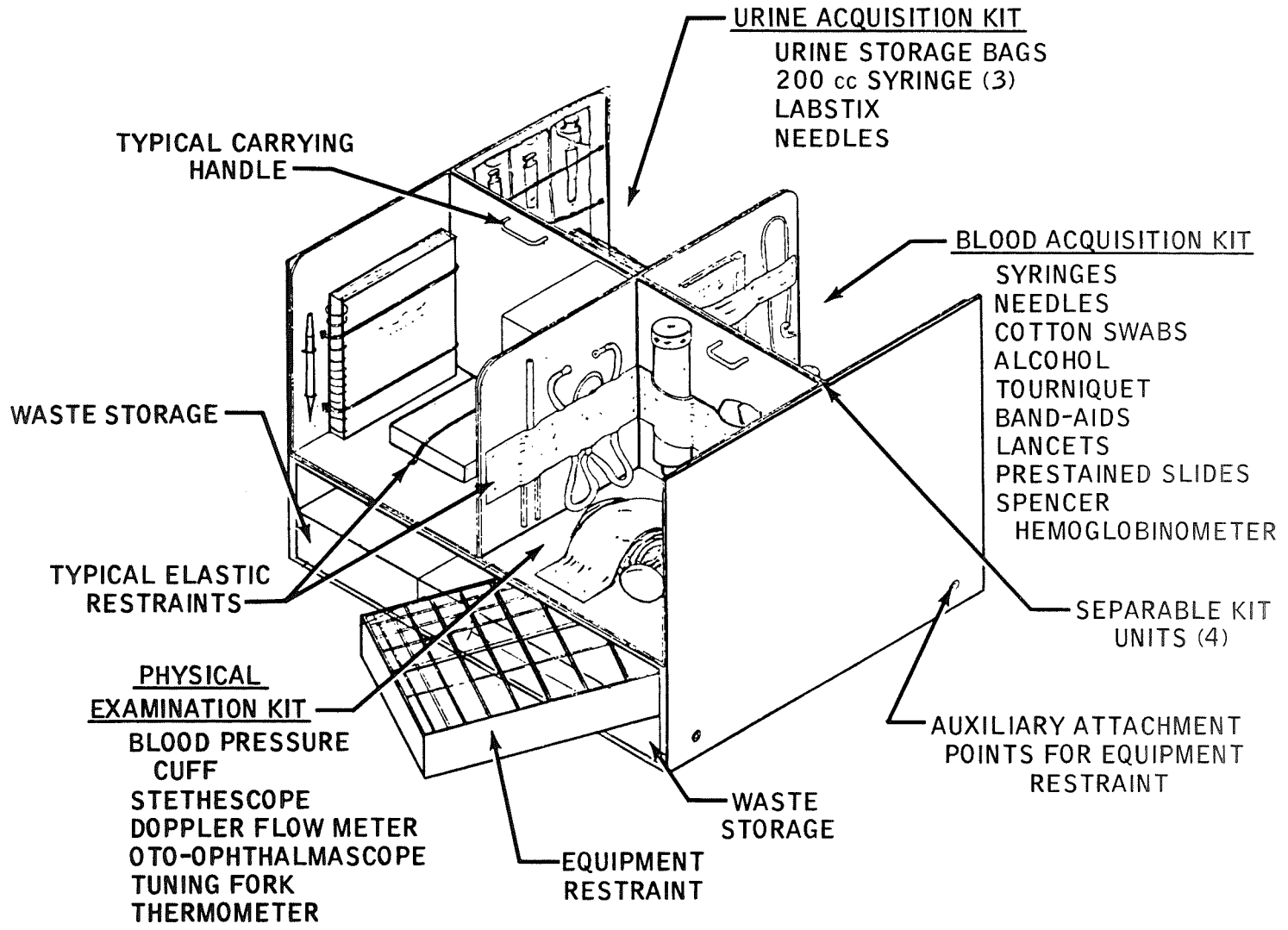

Figure 11.- Conceptual design sketch of biomedical COL (NASA-S-76-10158).

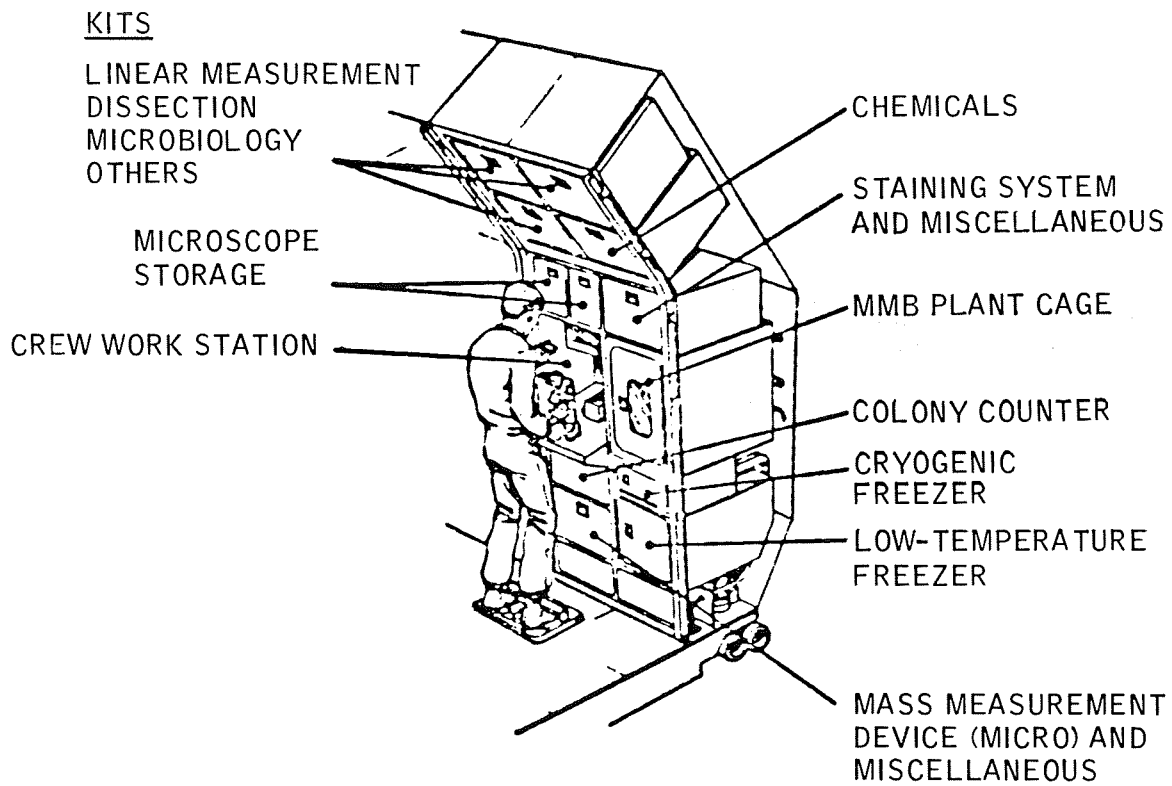
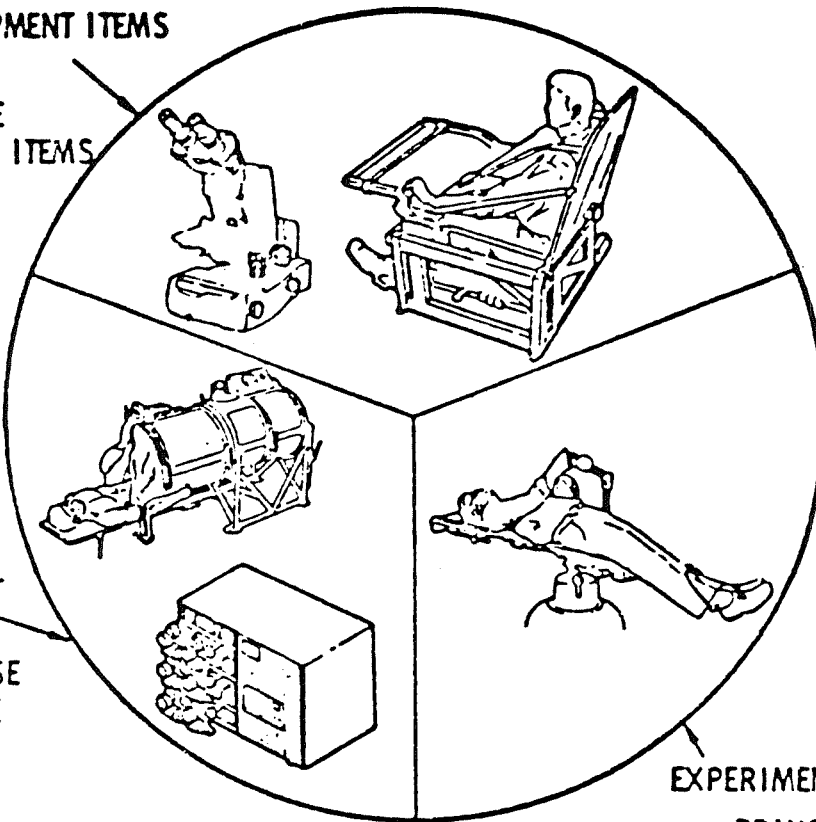

Figure 12.- Typical minilab for biological specimen examination and experimentation.

CORE REGULAR EQUIPMENT ITEMS

- MULTI-PURPOSE
- HIGH REUSE RATE
- MAJOR CRITICAL ITEMS



CORE INTERMITTENT ITEMS

- MULTI-PURPOSE
- LIMITED REUSE

EXPERIMENT SPECIFIC

- PRINCIPAL INVESTIGATORS
SPECIAL USE ITEMS

Figure 14.- Common operational research equipment.