

General Disclaimer

One or more of the Following Statements may affect this Document

- This document has been reproduced from the best copy furnished by the organizational source. It is being released in the interest of making available as much information as possible.
- This document may contain data, which exceeds the sheet parameters. It was furnished in this condition by the organizational source and is the best copy available.
- This document may contain tone-on-tone or color graphs, charts and/or pictures, which have been reproduced in black and white.
- This document is paginated as submitted by the original source.
- Portions of this document are not fully legible due to the historical nature of some of the material. However, it is the best reproduction available from the original submission.

**NASA TECHNICAL
MEMORANDUM**

NASA TM X-73987

NASA TM X-73987

(NASA-TM-X-73987) COMPUTER PROGRAM FOR
CALCULATING AERODYNAMIC CHARACTERISTICS OF
UPPER-SURFACE-BLOWING AND OVER-WING-BLOWING
CONFIGURATIONS (NASA) 38 p HC A03/MF A01

N77-18055

**Unclas
CSCL 01A G3/02 17250**

COMPUTER PROGRAM FOR CALCULATING AERODYNAMIC CHARACTERISTICS OF
UPPER-SURFACE-BLOWING AND OVER-WING-BLOWING CONFIGURATIONS

BY

Dr. C. Edward Lan and Greg L. Fillman, University of Kansas and
Charles H. Fox, Jr., NASA Langley Research Center



February 1977

This informal documentation medium is used to provide accelerated or special release of technical information to selected users. The contents may not meet NASA formal editing and publication standards, may be revised, or may be incorporated in another publication.

**NATIONAL AERONAUTICS AND SPACE ADMINISTRATION
LANGLEY RESEARCH CENTER, HAMPTON, VIRGINIA 23665**

1. Report No. NASA TM X-73987		2. Government Accession No.		3. Recipient's Catalog No.	
4. Title and Subtitle A COMPUTER PROGRAM FOR CALCULATING AERODYNAMIC CHARACTERISTICS OF UPPER-SURFACE-BLOWING AND OVER-WING-BLOWING CONFIGURATIONS				5. Report Date February 1977	
				6. Performing Organization Code	
7. Author(s) Dr. C. Edward Lan and Greg L. Fillman, University of Kansas and Charles H. Fox, Jr., NASA Langley Research Center				8. Performing Organization Report No.	
				10. Work Unit No.	
9. Performing Organization Name and Address NASA Langley Research Center Hampton, VA 23665				11. Contract or Grant No.	
				13. Type of Report and Period Covered Technical Memorandum	
12. Sponsoring Agency Name and Address National Aeronautics and Space Administration Washington, DC 20546				14. Sponsoring Agency Code	
15. Supplementary Notes					
16. Abstract This document describes in detail the necessary information for using a computer program to calculate the aerodynamic characteristics of upper-surface-blowing (USB) and over-wing-blowing (OWB) configurations. The program is based on the inviscid wing-jet interaction theory of Lan and Campbell, and the jet entrainment theory of Lan. In the interaction theory, the flow perturbations are computed both inside and outside the jet, separately, and then matched on the jet surface to satisfy the jet-boundary conditions. The jet Mach number is allowed to be different from the freestream value (Mach number nonuniformity). These jet-boundary conditions require that the static pressure be continuous across the jet surface which must always remain as a stream surface. These conditions, as well as the wing-surface tangency condition, are satisfied only in the linearized sense. The detailed formulation of these boundary conditions is based on the quasi-vortex-lattice method of Lan. The main assumptions used in developing the theory are as follows: (1) the flow perturbations, both inside and outside the jet, satisfy the Prandtl-Glauert equation and all boundary conditions have been linearized; (2) the jet is either of the rectangular or circular shape with constant cross section and constant properties in the unperturbed flow for the purpose of interaction calculations; and (3) no fuselage, nacelles, or wing thickness are accounted for. The program is written in Fortran language and runs on CDC 6600 and Honeywell 66/60 computers. It is available from COSMIC of the University of Georgia, Athens, Georgia.					
17. Key Words (Suggested by Author(s)) theoretical aerodynamics upper-surface-blowing over-wing-blowing subsonic Mach number			18. Distribution Statement Unclassified-Unlimited		
19. Security Classif. (of this report) Unclassified		20. Security Classif. (of this page) Unclassified		21. No. of Pages 119	22. Price \$5.50

A COMPUTER PROGRAM FOR CALCULATING AERODYNAMIC CHARACTERISTICS
OF UPPER-SURFACE-BLOWING AND OVER-WING-BLOWING CONFIGURATIONS

by

C. Edward Lan
Greg L. Fillman

University of Kansas

and

Charles H. Fox, Jr.
NASA Langley Research Center

INTRODUCTION

This document describes in detail the necessary information for using a computer program to calculate the aerodynamic characteristics of upper-surface-blowing (USB) and over-wing-blowing (OWB) configurations. The program is based on the inviscid wing-jet interaction theory described in references 1 and 2, and the jet entrainment theory developed in reference 3. In the interaction theory, the flow perturbations are computed both inside and outside the jet, separately, and then matched on the jet surface to satisfy the jet-boundary conditions. The jet Mach number is allowed to be different from the freestream value (Mach number nonuniformity). These jet-boundary conditions require that the static pressure be continuous across the

jet surface which must always remain as a stream surface. These conditions, as well as the wing-surface tangency condition, are satisfied only in the linearized sense. The detailed formulation of these boundary conditions is based on the quasi-vortex-lattice method (reference 4).

The main assumptions used in developing the theory are as follows: (1) the flow perturbations, both inside and outside the jet, satisfy the Prandtl-Glauert equation and all boundary conditions have been linearized; (2) the jet is either of the rectangular or circular shape with constant cross section and constant properties in the unperturbed flow for the purpose of interaction calculations; and (3) no fuselage, nacelles, or wing thickness are accounted for.

The program is written in Fortran language and runs on CDC 6600 and Honeywell 66/60 computers. It is available from COSMIC of the University of Georgia, Athens, Georgia.

SYMBOLS

A_j	cross sectional area of the jet
C_T	thrust coefficient = V_j/qS_w
M_j	Mach number of the jet
M_∞	Mach number of the freestream
P_{tj}	jet total pressure
P_∞	freestream total pressure
q	freestream dynamic pressure
S_w	wing area
T_j	temperature of the jet (total)
T_∞	freestream total temperature
V_j	jet velocity
V_∞	freestream velocity
AR	wing aspect ratio
L.E.	leading edge
T.E.	trailing edge
ρ_j	jet density
ρ_∞	freestream density
γ	ratio of specific heats

COMPUTER PROGRAM DESCRIPTION

Program Capabilities

This computer program provides a theoretical method for determining the aerodynamic characteristics of arbitrary wings under the influence of a single centered jet or a pair of jets blowing on or above the plane of the wing. The program is applicable to both USB and OWB configurations. The most important characteristic of the program is the ability to account for both the jet entrainment and the inviscid wing-jet interaction processes in calculating the aerodynamic characteristics of the wing. The entrainment theory is applicable to compressible heated jets and the interaction theory can be applied to jets with Mach number nonuniformity. The following is a list of the aerodynamic characteristics the program will calculate:

1. Spanwise and chordwise pressure distributions, ΔC_p , across the wing for both the jet-on and wing-alone cases.
2. The spanwise distribution of sectional lift, induced-drag and pitching moment coefficients due to circulation for both the jet-on and wing alone cases.
3. The total lift, induced-drag and moment coefficients due to circulation when both entrainment and interaction are accounted for.
4. For OWB configurations, the total lift, drag and moment coefficients due to circulation are calculated recognizing only entrainment effects, thus establishing the relative importance of entrainment and interaction for a particular configuration.

5. For USB configurations, the force and moment coefficients due to coanda turning of the jet.
6. The total force and moment coefficients for the wing alone case.

Wing-Jet Geometry Limitations

As already mentioned, this program can be applied to configurations which employ a single jet centered on or above the root chord of the planform or two jets symmetrically located on the left and right wing, respectively. The jet cross-section shape may be round or rectangular. The jet exit may be located in any position relative to the wing so long as the bottom edge of the exit is on or above the plane of the wing. It is always assumed that the jet is blowing parallel to the root chord of the wing. No spanwise jet-velocity components can be accounted for. The jet may have any Mach number or temperature, although the freestream velocity must be subsonic.

The program has purposely been constructed so that a wide variety of wing planform geometries can be input. The wing may have linear twist and any conceivable camber desired. The camber may vary linearly from root to tip. The effect of wing thickness is unaccounted for, and the wing cannot have dihedral or anhedral. The wing may have as many as five separate flaps (all plain) and each may have its own shape and size as well as its own deflection angle (always positive). The root and tip chords of the wing and flaps must be parallel to the freestream. The wing leading and trailing edges

may not have any curvature but can consist of a series of straight lines. These edges may have slope-discontinuities or step shifts. This last statement also applies to the relative position of various flap hinge lines to each other. However, too many points of slope discontinuities would complicate the geometry input.

Preparation of Wing Planform Geometry

In order to prepare the wing planform geometry, the top-view of the right half of wing must be plotted in an X-Y coordinate system (see Fig. 1). The X axis is located at the root chord and oriented in the streamwise direction. The position of the wing relative to the Y-axis is arbitrary, but all pitching moments are calculated relative to the Y-axis. Even if the wing has camber and flap deflections the wing should be plotted as a flat plate with zero flap deflection. (see Figure 1(a))

The wing should now be divided into a number of individual panels by drawing in break lines, which should be parallel to the X-axis and extend across the entire wing. (See figure 1(b)). These break lines should be drawn from such discontinuities as a slope change in the leading or trailing edge or the inboard and outboard edges of flaps. In addition, lines should extend from the inboard and outboard edges of the jet exit. If the exit is above the X-Y plane of the wing then the top-view projection of the exit onto the wing plane must be used. The portion of the wing between these two lines i.e. (the part of the wing under the jet) will be

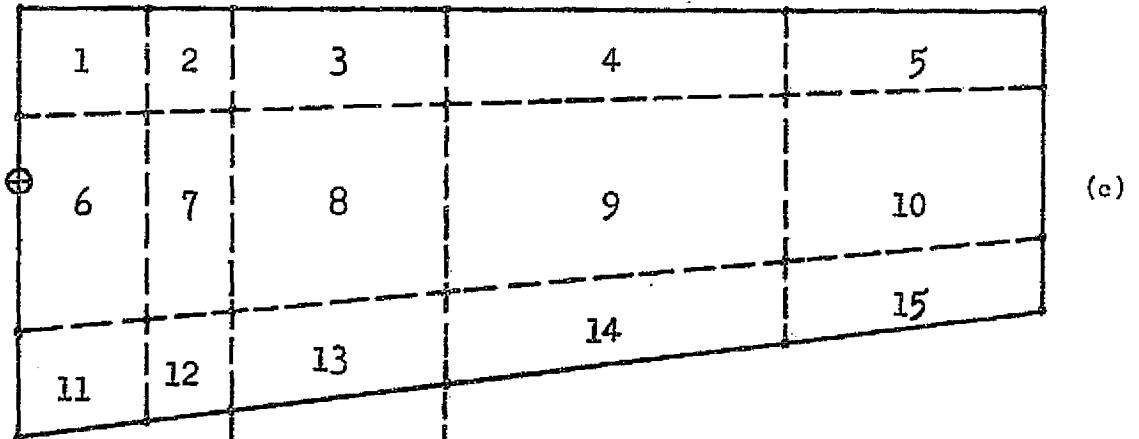
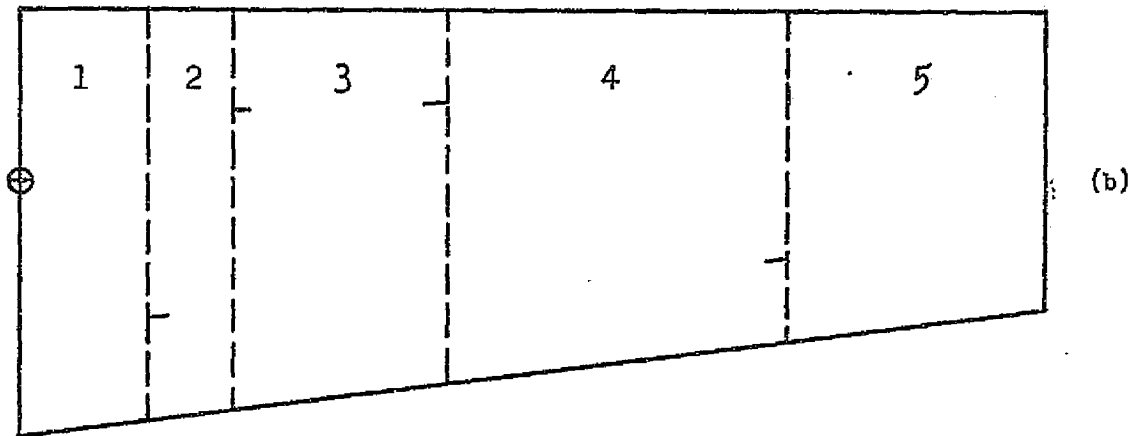
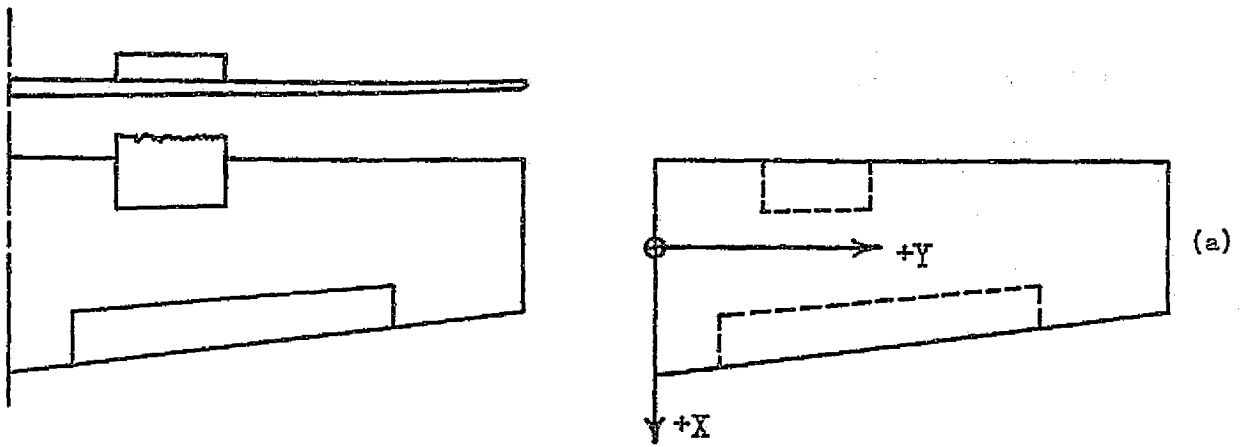

Trailing
Jet
Section

Figure 1 Preparation of the Wing Planform Geometry

referred to as the jet span. In figure 1(b) there are 3 spans within the influence of the flap, so there will be 3 flap sections ($NFP=3$) even though they represent only 1 flap. The spans are always numbered from inboard to outboard and the numerical order of the flap and jet spans amongst the spanwise sections is 2, 3, 4 in figure 1(b). Of these 3 spans the jet span is the second from the left so the numerical order of the jet span is 2, ($NJP = 2$). The number NJP should not be confused with the numerical order of the flap and jet spans amongst the other spans. The wing may be divided spanwise into as many as 8 individual spans. (Variables NFP, NJP, are defined in the input data format)

Once this is done the spans must be subdivided in the chordwise direction into individual wing sections. In the chordwise direction the wing can be divided into a maximum of three sections. (See Fig. 1(c)). Break lines should be drawn from the root chord to the tip chord along such discontinuities as the flap hinges or the aft edge of the jet exit. These break lines may exhibit slope changes or a step jump at the border of each wing span. This would be the case if a wing has two or more flaps whose hinge lines do not lie upon the same line. If it is possible, it is best to draw the chordwise break lines such that they lie along a constant percentage of the wing chords. This helps to make the distribution of wing vortex elements more uniform. This is the case in figure 1(c), where both the jet exit and the flap hinge are constant percentage chordwise lines.

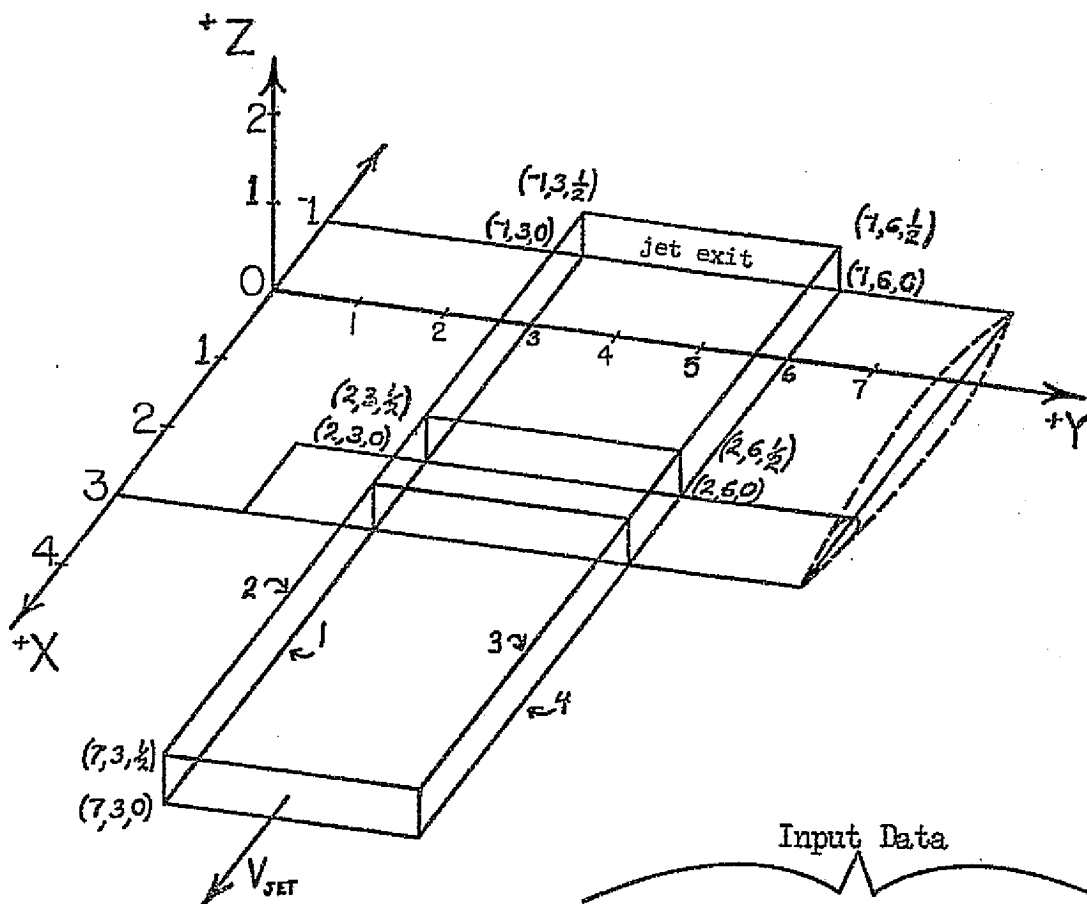

Input Data

Card	Jet Section	Edge (I)	XXL(I)	XXT(I)	YL(I)	ZL(I)
1	1st	1	-1	2	3	0
2		2	-1	2	3	.5
3		3	-1	2	6	.5
4		4	-1	2	6	0
5	2nd	1	2	3	3	0
6		2	2	3	3	.5
7		3	2	3	6	.5
8		4	2	3	6	0
9	3rd	1	3	7	3	0
10		2	3	7	3	.5
11		3	3	7	6	.5
12		4	3	7	6	0

Figure 2 Input Coordinates For USB Jet Sections

The wing sections should be numbered from inboard to outboard starting with the most forward row. The jet span of figure 1(c) has been divided into three sections and, although the jet exit lies on the boundary between section 3 and section 8, all three sections are considered jet sections. Another jet section must always be added downstream of the wing with a streamwise length of at least one local chord length. This section is referred to as the trailing jet section. The only instance when the jet sections do not extend to the leading edge is when the jet exit is located on or above the trailing edge. In this case only the trailing jet section is considered a jet section. If the jet exit is forward of the leading edge, another jet section must be added to include the area between the jet exit and the leading edge. A maximum of 4 jet sections are allowed. If the job to be run is an OWB configuration, then only the X-Y coordinates of the jet section corner points need be defined. However, if the job is an USB configuration, then the jet sections must be thought of as rectangular parallelepipeds whose lower surfaces are on or above the plane of the wing, and whose thickness is that of the rectangular jet exit. Coordinates for each of the four edges of these parallelepipeds must be input as shown in figure 2. There will be four cards per jet section. The jet sections will be defined starting with the most forward section and working toward the trailing jet section. Even if the trailing jet is deflected down by a flap deflection, the coordinates for this section must be input as if there is no deflection of the jet and its lower surface remains on

the X-Y plane. If the jet exit is on the wing plane, the Z coordinates of the lower surface of each section must always be zero, even if the wing surface is cambered.

Vortex Element Distribution

Small horseshoe vortex elements must be distributed across the entire wing as evenly as possible. This is done by allotting each wing section a certain number of vortex elements according to the relative size of the sections. The bound portion of the vortices are aligned in a matrix pattern of columns and rows within each wing section. Each wing section must have at least 2 bound elements in the spanwise direction and 2 elements in the chordwise direction; i.e. each wing section must be allocated at least 4 vortex elements.

The wing sections are also arranged in columns and rows. All wing sections in the same row must have the same chordwise distribution of vortex elements. For example, in fig. 1(c) if $NW(1) = 2$, then wing sections 1 thru 5 all have 2 chordwise vortex elements. If the wing is divided into 3 sections in the chordwise direction, then setting $NW(1) = 2$, $NW(2) = 3$, $NW(3) = 2$ should produce good results. If a wing has no flap and the jet exit is forward of the leading edge, then there will be no chordwise divisions of the wing, and $NW(1) = 5$ should produce good results. In this case $NW(2)$ and $NW(3)$ would be set equal to 0.

All wing sections in the same column must have the same spanwise vortex element distribution. If, for example, in fig. 1(c) $ML(4) = 5$, then sections 4, 9, and 14 all have 4 spanwise vortex strips. $ML(I)$

OWB ROUND JETS

USB RECTANGULAR JETS

Centered Jets

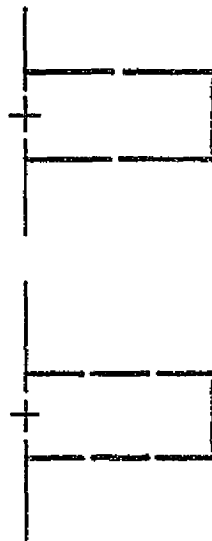
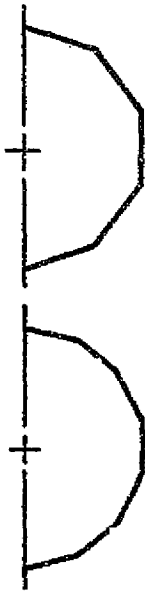

Outboard Jets

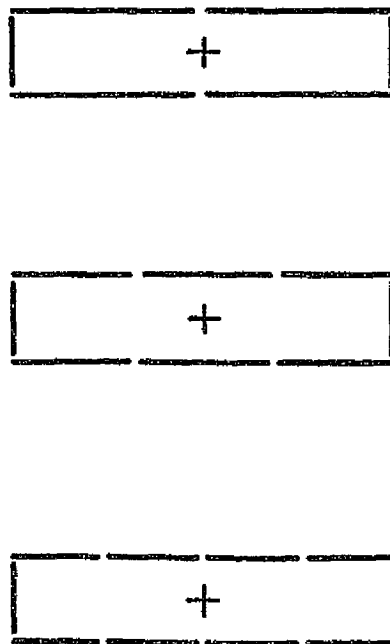
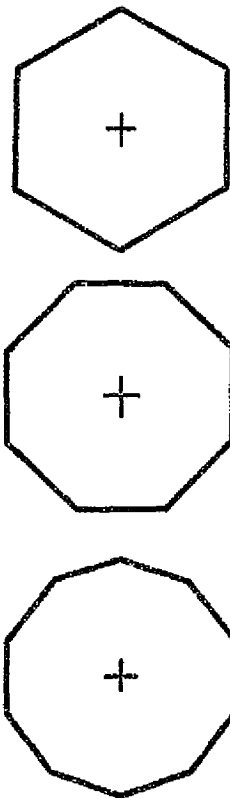

Vortex Strips	NSJ	MI(I)
5	6	3
7	8	4
6	5	3
8	7	4
10	9	5

Figure 3 Vortex Models of Circular and Rectangular Jets

is always equal to the number of vortex strips plus 1. Narrow wing sections should have only 2 or 3 vortex strips while wide wing sections should have 4 ($ML(I) = 5$) to 6 ($ML(I) = 7$) strips.

The jet circumference is covered with vortex strips in the manner indicated in Fig. 3. Vortex strips are arranged either in a rectangular pattern for USB jets or to form a regular polygon for OWB circular jets. In either case, the inboard and outboard edges of the jet are always normal to the wing plane. Referring to figure 3, if 8 vortex strips are used to model a non-centered jet, in either a rectangular or circular shape, 2 of the strips will be positioned to form the inboard and outboard edges leaving 3 strips to span the top of the jet and 3 strips to span the bottom. In this case the blown wing sections (jet sections) must also have 3 vortex strips ($ML(I) = 4$). Wing and jet vortex strips must always be coordinated in this manner. The centered jet configurations must also exhibit the same spanwise coordination of vortex strips. The following equations can be used as a check:

Centered Jet

$$ML(1) = \frac{NSJ}{2}$$

Outboard Jet

$$ML(I)_{JET} = \frac{NSJ + 1}{2}$$

The chordwise distribution of vortex elements for the wing sections and jet sections must also be identical. The trailing jet section should have 6 elements in the chordwise direction if it is

deflected. If it is undeflected, 4 elements will suffice. The maximum number of vortex elements that can be used to model the wing is 100. The total number of vortices representing the wing can be determined with the following equation:

$$LPANEL = [NW(1) + NW(2) + NW(3)] \times \left[\sum_{I=1}^{NC} (MI(I) - 1) \right]$$

A maximum of 100 elements can be used to model the jet surface. However, an equal number of jet vortices is used to represent perturbations inside the jet region. Thus, the total number of unknowns allowed for both the wing and jet is 300.

The number of vortex elements used to represent the outside (or inside) of the jet surface can be computed as follows:

Centered jet

$$JPANEL = \left[\sum_{I=1}^{NNJ} NCJ(I) \right] \times [NSJ - 1]$$

Outboard jet

$$JPANEL = \left[\sum_{I=1}^{NNJ} NCJ(I) \right] \times [NSJ + 1]$$

The total number of unknowns to be solved, including the jet vortices for the jet flow in the present two-vortex-sheet representation of the jet interaction, is then

$$LTOTAL = LPANEL + 2 \times JPANEL$$

INPUT DATA FORMAT

Group 1. Format 13A6 1 card

Any title identifying the cases to be run.

Group 2. Format 3(6X,I4) 1 card

ICASE Number of cases to be run.

NG = 0 if all cases have the same geometry other than the angle of attack.

= 1 if new configurations or different freestream-jet velocity ratios are to be treated.

ISYM = 0 for a centered jet

= 1, otherwise.

Group 3. Format 8F10.5 1 card.

AM1 Mach number of the freestream

AM2 Mach number of the jet flow

VMU Freestream velocity divided by jet velocity.

TEMP Jet total temperature divided by freestream total temperature. Assumed to be the same as ratio of freestream density and jet density.

ALP Angle of attack in degrees.

XEL X-coordinate of the wing L.E. at the jet centerline.

XET X-coordinate of the wing T.E. at the jet centerline.

Note: If the thrust coefficient is given, VMU may be computed as

$$\frac{V_j}{V_\infty} = \frac{1}{2} \left\{ 1 + \left[1 + \frac{2C_T (S_w/2)^{1/2}}{A_j (\rho_j/\rho_\infty)} \right] \right\}$$

$$VMU = V_{\infty}/V_j$$

where C_T = thrust coefficient

S_w = wing area used to define C_T .

A_j = jet cross-sectional area

If the nozzle pressure ratio, $p_{t,j}/p_{\infty}$, is given, the following isentropic relations may be used.

$$M_j^2 = \frac{2}{\gamma-1} \left[\left(\frac{p_{t,j}}{p_{\infty}} \right)^{\frac{\gamma-1}{\gamma}} - 1 \right]$$

$$\frac{T_j}{T_{\infty}} = \frac{1 + \frac{\gamma-1}{2} M_{\infty}^2}{1 + \frac{\gamma-1}{2} M_j^2}$$

$$\frac{V_{\infty}}{V_j} = VMU = \frac{M_{\infty}}{M_j} \frac{1}{\left(\frac{T_j}{T_{\infty}} \right)^{1/2}}$$

Group 4. Format 2(6X, 14) 5F10.5

NFP Number of flap sections, including the jet span,
A maximum of five flap sections may be input.

NJP Numerical order of the jet span among the NFP sections.

DF(I) Flap deflection angles in degrees for the flap sections.
I=1, NFP

Group 5. Format 7F10.5 1 card

HALFSW One half of the reference wing area.

TWIST Difference in angles of attack at the tip and the root
in deg. Negative for washout.

TWISTR Incidence angle of the root chord in degrees.
XJ X, Y, and Z-coordinates of the midpoint of the jet cross-
YJ section at the exit.
ZJ
RJ Jet radius.

Note: The last four variables are needed only for over-wing-blowing applications. They may be any non-zero numbers for USB applications, unless the rectangular jet is not on the wing surface and the entrainment effect is to be accounted for. For the latter case, these variables are used to define the equivalent circular jet.

Group 6. Format 7F10.5 1 card

TEANGL Trailing-edge half angle of the airfoil at the jet center-
line in deg. For USB applications, it may be arbitrary.
PTIAL = 0. for clean or full-span flap configuration
= 1. for partial-span flap deflection.
USB = 1. for USB applications
= 0. for OWB applications
CAMLER L.E. camber slope at the root leading edge
CAMLET L.E. camber slope at the tip leading edge.
CAMTER T.E. camber slope at the root trailing edge
CAMTET T.E. camber slope at the tip trailing edge.

Note: For USB applications, TEANGL may be any value. If the camber ordinates are to be read in, the leading edge and trailing edge camber slopes may be arbitrary numbers.

Note: The following card must be omitted for OWB applications.

Group 7 Format 3F10.5 1 card

CMU Jet thrust coefficient

DFJ Jet deflection angle in degrees at the trailing edge relative to the chord line. At small flap angles, it may be taken as the sum of flap angle and the airfoil trailing edge half angle. At large flap angles, experimental values should be used.

TNJ = 0. if the entrainment is not to be accounted for. Usually this is the case if the jet is on the wing surface.
= 1. if the entrainment due to an equivalent round jet is to be accounted for when a rectangular jet is not on the wing surface.

Group 8 Format 8(6X, I4) 1 card

NC Number of spanwise sections. A natural way of dividing a planform into sections is to follow lines of discontinuity, such as edges of partial-span flap, jet boundaries, wing edge discontinuities, etc. See Figure 1. NC is limited to 8.

M1(I) Number of vortex strips in each spanwise section, plus one.

·
· Minimum value for each is 3. Maximum for each M1(I) is 31.

·
I=1,NC The total number of spanwise strips is limited to 30.

Group 9 5(6X, I4) 1 card

NJW(I) The numerical order of the flap and jet spans among
I=1,NFP the spanwise sections.

Group 10 Format 5(6X, I4) 1 card

NW(1) Number of chordwise vortex elements in each chordwise section.

NW(2) The planform is divided into chordwise sections according

NW(3) to such lines of discontinuity as jet exit, flap hinge, etc.

If there is only one section, SET NW(2) = NW(3) = 0. For
2 sections, SET NW(3) = 0.

ICAM = 1 if the camber ordinates of the airfoils are to be
read in.

= 0, otherwise. In this case, the camber functions $\left(\frac{dz}{dx}\right)$
in close-form expressions are to be inserted manually into
subprograms ZCR(x) and ZCT(X), the root chord and tip
chord camber functions, respectively.

IM Number of camber ordinates to be read in. (Limited to eleven).
Arbitrary if ICAM = 0.

Note: Group 11 must be deleted if ICAM = 0.

Group 11. Format 8F10.5 4 or 8 cards

XT(1,J), J=1,IM Non-dimensional x-coordinates to define root
camber.

ZC(1,J), J=1,IM Non-dimensional camber ordinates of the
root chord.

XT(2,J), J=1,IM Non-dimensional x-coordinates to define tip camber.

ZC(2,J), J=1,IM Non-dimensional camber ordinates of the tip chord.

Group 12. Format 6F10.5 1 card for each wing section.

XXL(1) x-coordinate of the leading edge of the inboard boundary
chord of a given spanwise section.

XXT(1) x-coordinate of the trailing edge of the inboard boundary
chord of the same spanwise section.

YL(1) y-coordinate of the inboard boundary chord.
XXL(2) x-coordinate of the leading edge of the outboard boundary
chord of the same spanwise section.
XXT(2) x-coordinate of the trailing edge of the outboard boundary chord
YL(2) y-coordinate of the outboard boundary chord.

Group 13. Format 6(6X, I4), 1 card

NNJ Number of jet sections.

Note. The jet region above or on the wing must be divided into streamwise sections by following the divided planform pattern. It is important to start the jet sections always from the wing leading edge even if the jet exit is downstream of the leading edge. The only exception is when the jet exit is at the trailing edge. In this case, NNJ=1 and the jet section starts from the trailing edge. NNJ is limited to 4. For the configuration of Figure 1, NNJ=4.

NSJ = Number of jet circumferential strips minus one for a non-centered jet (always use odd numbers).
= Number of jet circumferential strips on the half jet plus one for a centered jet (always use even numbers). See figure 3.

NCJ(I), No. of streamwise vortex elements in each section. There
I=1, NNJ should be NNJ numbers. For those jet sections above the wing, these numbers should agree with the corresponding numbers of wing vortices. See NW(1), NW(2), NW(3) in Group 10.

Note: Group 14 must be deleted for USB applications

Group 14. Format 6F10.5 NNJ cards

XXL(1)

XXT(1)

YL(1)

XXL(2) Coordinates of bounding chords of the jet section

XXT(2) projected on the x-y plane. For definition, see Group 12.

YL(2)

Note. Group 15 is to be deleted for OWB applications.

Group 15. Format 4F10.5 (4XNNJ) cards.

XXL(I) Coordinates of the bounding lines defining the

XXF(I) rectangular jet sections in USB applications.

YL(I) They are the x-coordinates of the leading and

ZL(I) trailing edges, the y-coordinate and the z-

I=1,...,4 coordinate of the bounding line. The 4 stream-

wise edges of each section are defined in the

order illustrated in figure 2. There are 4

cards for each jet section. The jet section be-

hind the trailing edge, (trailing jet section),

should be at least one local chord in length.

Group 16 Format F10.5 (ICASE-1) cards

ALP angles of attack in degrees. These cards are to be included only if additional angles of attack for the same configuration and VMU (NG=0) are to be run.

Note: The read statements for the input data in group 3 thru group 15 can be seen in subroutine "GEOMTY" of the program listing along with a short definition of the parameters to be read in. The read statements for groups 1, 2, and 16 along with the corresponding parameter definitions can be seen near the beginning of the program listing in the main routine.

Pre-Run Check List

Before the program is run, the following checklist should be completed:

- (1) The array, GAMMA, defined in the subroutine "SOLUTN", should be dimensioned to have at least $(N+1)^2/4$ elements, where N is the total number of unknowns (= LTOTAL).
- (2) For $N = 283$, the minimum memory needed is 42K (decimal). For any other N , the required memory can be computed accordingly, based on the change in GAMMA array.
- (3) The root and tip camber slope functions should be defined manually in the subprograms ZCR(X), ZCT(X) respectively, otherwise the root and tip camber ordinates should be read in. The camber slope function, dz_c/dx , is defined with respect to a unit chord length.
- (4) Two temporary files or tapes must be provided, one being designated as (01) and the other (02).
- (5) Check input data.

OUTPUT DATA FORMAT

First the title of the job and the input data will be printed in the same format as it was input. If the job is an over-wing blowing configuration the computed jet entrainment will be printed after the fourth line of input data as follows:

XJET Downstream distance of a given cross-section from the jet exit divided by the jet radius at the exit (r_0).

R_{JET} the radius of the jet cross section divided by the original jet radius (r_0).

$\frac{DM}{DX}$ Values printed are actually the nondimensionalized entrainment function $E(\bar{x})$ (see equation 33 of reference 3)

HALF SW the reference half-wing area

CREF the reference mean chord = $\frac{S_{wing}}{b} = \frac{HALF SW}{b/2}$

LPANEL the number of wing vortices

JPANEL the number of outer (or inner) jet vortices

LAST the number of wing vortices plus the number of outer jet vortices. LAST = LPANEL + JPANEL

LTOTAL LTOTAL is the total number of vortices used which is also the total number of unknowns to be solved.

 LTOTAL = LPANEL + 2 (JPANEL) = LAST + JPANEL

If the job is an OWB configuration a note will be printed at this time indicating the shape of the equivalent jet cross-section used for the interaction computations along with 3 parameters defined below.

1. x-coordinate where the equivalent jet properties are evaluated.

2. Equivalent Jet Radius: the radius of the jet at the x location listed above
3. $\frac{V_o}{V_j}$ the velocity ratio of the equivalent jet.

Vortex Element Endpoint Coordinates

(X_1, Y_1, Z_1) coordinates for the inboard endpoint of a bound vortex element

(X_2, Y_2, Z_2) coordinates for the corresponding outboard endpoint.
Wing elements are listed first and then jet elements.
The number of elements listed should equal (LAST).

Control Point Coordinates

2 columns of control point coordinates, one point for each vortex element. Number of points listed should equal (LAST).

Sectional Pressure and Force Data

XV	Percent chord location
YV	Percent span location
CP	the total ΔC_p at the given (XV, YV) point due to both wing and jet induced circulation
CPW	The ΔC_p that would occur at that same point for the wing alone case
Y/SP	the y-coordinate of the chord in question divided by the half-span
CL	The sectional lift coefficient due to circulation (jet on), nondimensionalized with $q_\infty c$.
CM	The sectional pitching moment coefficient about the Y-axis, nondimensionalized with $q_\infty c^2$.
CT	The sectional leading edge thrust coefficient, nondimensionalized with $q_\infty c$.
CDI	The sectional induced drag coefficient, nondimensionalized with $q_\infty c$.
CLW	The sectional lift coefficient for the wing alone case
CMW	The sectional pitching moment about the Y-axis for the wing alone case
CDW	The sectional induced drag coefficient for the wing alone case.

Total Force and Moment Data

The Lift Coefficient - The total circulation lift coefficient due to the wing, wing-jet interaction and entrainment (if any).

Total Induced Drag Coefficient Total induced drag coeff. for the jet on case

Induced drag = parameter $\frac{C_{D_I}}{C_L^2}$ or $\frac{1}{\pi e AR}$

Total Pitching Moment Coefficient = Pitching moment coefficient due to all circulation forces, about the Y-axis. Nondimensionalized with CREF.

Note: In the case of OWB jobs, these coefficients reflect the total jet-on forces and moments, but for USB jobs the coanda force and moment coefficients must be added to these; see below.

USB Jobs

Coanda Lift Coefficient - The lift coefficient due to the lift component of the jet reaction force

Coanda Drag Coefficient - Drag coefficient due to the drag component of the jet reaction.

The Coanda Moment Coeff. - Pitching moment coefficient due to the pitching moment caused by the jet reaction force (about Y-axis).

O.W.B. Jobs

In the case of O.W.B. jobs the next three coefficients listed have the same definition as the first three except that the effects of wing-jet interaction have been omitted from the computation.

All Jobs

The last four coefficients printed are due to aerodynamic forces and moments generated solely by the wing without any jet effects. (jet off)

EXAMPLE INPUT AND OUTPUT

The following is an example of a simple over-wing blowing configuration including a listing of the input data cards and the corresponding output. (See figure 4) Following this is an example of an upper surface blowing job; see figure 5. Figure 6 is a plot of the wing and jet vortices for this USB job, which was made with the listing of the vortex endpoint coordinates in the output. Finally figure 7 is an illustration of one way of breaking down a more complicated wing into individual wing and jet sections.

Listing of Input Data Cards for the OWB Example Job

card							
1	*** FALK'S WING 1 WITH VMU=0.250***						
2		1	1	0			
3	0.	0.	0.250	1.	6.	0.	0.
4		1	1	0.0			
5	1.	0.	0.	-1.39536	0.	.17442	0.11628
6	5.25	0.	0.	0.	0.	0.	0.
7		2	3	9			
8		1					
9		5	0	0	0	0	
10	0.	1.	0.	0.	1.	0.11628	
11	0.	1.	0.11628	0.	1.	1.	
12		3	6	4	5	4	
13	-1.39536	0.	0.	-1.39536	0.	0.11628	
14	0.	1.	0.	0.	1.	0.11628	
15	1.	2.	0.	1.	2.	0.11628	

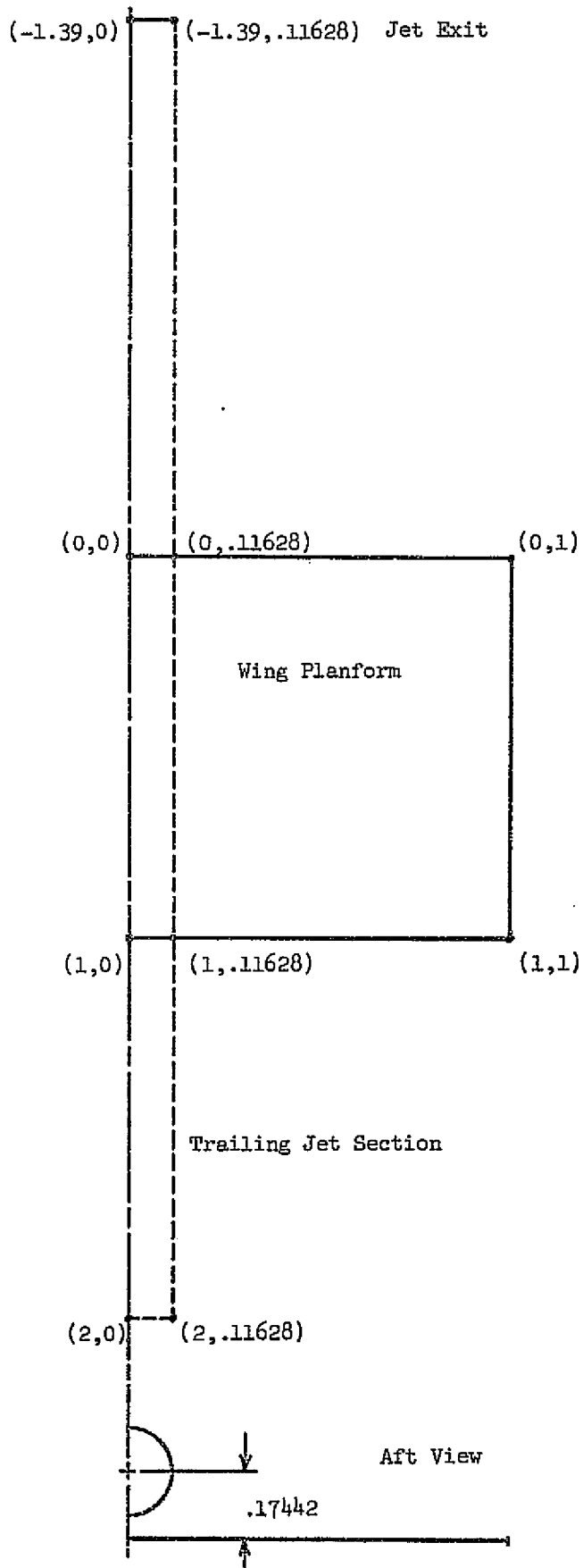

Figure 4 Wing and Jet Sections For The OWB Example

 *** FALKNS WING I WITH VMU=0.250***

OUTPUT FOR THE OWB TEST CASE

1 1 0

XXXXXXXXXXXXXXXXXXXXXXXXXX

CASE NUMBER = 1

XXXXXXXXXXXXXXXXXXXXXXXXXX

INFLT DATA

0.00000	0.00000	.25000	1.00000	0.00000	0.00000	0.00000
1	1		0.00000			
1.00000	0.00000	0.00000	-1.39530	0.00000	.17442	.11620
5.25000	0.00000	0.00000	0.00000	0.00000	0.00000	0.00000

THE COMPUTED JET ENTRAINMENT ARE AS FOLLOWS

XJET	RJET	CM/CX
9.50930	2.70463	.08796
10.25930	2.70463	.08796
11.75930	2.70571	.08792
13.25930	2.72650	.08707
14.75930	2.78574	.08469
16.25930	2.87620	.08118
17.75930	2.98591	.07713
19.25930	3.10629	.07293
20.75930	3.23305	.06877
22.25930	3.36106	.06482
23.75930	3.48925	.06110
25.25930	3.61646	.05764
26.75930	3.74197	.05442
28.25930	3.86537	.05144
29.75930	3.98643	.04869
31.25930	4.10501	.04614
32.75930	4.22110	.04379
34.25930	4.33467	.04161
35.75930	4.44578	.03959
37.25930	4.55448	.03772
38.75930	4.66083	.03597
40.25930	4.76491	.03435
41.75930	4.86681	.03284
43.25930	4.96659	.03143
44.75930	5.06434	.03011
46.25930	5.16014	.02888
47.75930	5.25408	.02772
49.25930	5.34616	.02664
50.75930	5.43653	.02562

52.25930	5.52523	.02466			
53.75930	5.61233	.02376			
2	3	5			
1					
5	0	0	0	0	
0.00000	1.00000	0.00000	0.00000	1.00000	.11628
0.00000	1.00000	.11628	0.00000	1.00000	1.00000
3	6	4	5	4	
-1.39536	0.00000	0.00000	-1.39536	0.00000	.11628
0.00000	1.00000	0.00000	0.00000	1.00000	.11628
1.00000	2.00000	0.00000	1.00000	2.00000	.11628

HALF SW= .10000E+01 CREFF= .10000E+01

LPANEL= 50 JPANEL= 65 LAST=115 LTCTAL=180

XX

A RECTANGULAR JET WITH LATERAL EXTENT EQUAL TO THE EQUIVALENT JET DIAMETER IS USED FOR INTERACTION COMPUTATION

NOTE. CHECK WHETHER THE WING IS IMMERSED IN THE JET

XX

THE EQUIVALENT JET PROPERTIES ARE EVALUATED AT -.00000

THE EQUIVALENT JET RADIUS IS .22168

THE VELOCITY RATIO OF THE EQUIVALENT JET, V0/VJ, IS .41935

VORTEX ELEMENT ENDPOINT COORDINATES=

X1	X2	Y1	Y2	Z1	Z2
.02447	.02447	0.00000	.11084	0.00000	0.00000
.20611	.20611	0.00000	.11084	0.00000	0.00000
.50000	.50000	0.00000	.11084	0.00000	0.00000
.79389	.79389	0.00000	.11084	0.00000	0.00000
.97553	.97553	0.00000	.11084	0.00000	0.00000
.02447	.02447	.11084	.22168	0.00000	0.00000
.20611	.20611	.11084	.22168	0.00000	0.00000
.50000	.50000	.11084	.22168	0.00000	0.00000
.79389	.79389	.11084	.22168	0.00000	0.00000
.97553	.97553	.11084	.22168	0.00000	0.00000
.02447	.02447	.22168	.27381	0.00000	0.00000
.20611	.20611	.22168	.27381	0.00000	0.00000
.50000	.50000	.22168	.27381	0.00000	0.00000
.79389	.79389	.22168	.27381	0.00000	0.00000
.97553	.97553	.22168	.27381	0.00000	0.00000
.02447	.02447	.27381	.36069	0.00000	0.00000

.20611	.20611	.27381	.36069	0.00000	0.00000
.50000	.50000	.27381	.36069	0.00000	0.00000
.79389	.79389	.27381	.36069	0.00000	0.00000
.97553	.97553	.27381	.36069	0.00000	0.00000
.02447	.02447	.36069	.47774	0.00000	0.00000
.20611	.20611	.36069	.47774	0.00000	0.00000
.50000	.50000	.36069	.47774	0.00000	0.00000
.79389	.79389	.36069	.47774	0.00000	0.00000
.97553	.97553	.36069	.47774	0.00000	0.00000
.02447	.02447	.47774	.61084	0.00000	0.00000
.20611	.20611	.47774	.61084	0.00000	0.00000
.50000	.50000	.47774	.61084	0.00000	0.00000
.79389	.79389	.47774	.61084	0.00000	0.00000
.97553	.97553	.47774	.61084	0.00000	0.00000
.02447	.02447	.61084	.74394	0.00000	0.00000
.20611	.20611	.61084	.74394	0.00000	0.00000
.50000	.50000	.61084	.74394	0.00000	0.00000
.79389	.79389	.61084	.74394	0.00000	0.00000
.97553	.97553	.61084	.74394	0.00000	0.00000
.02447	.02447	.74394	.86099	0.00000	0.00000
.20611	.20611	.74394	.86099	0.00000	0.00000
.50000	.50000	.74394	.86099	0.00000	0.00000
.79389	.79389	.74394	.86099	0.00000	0.00000
.97553	.97553	.74394	.86099	0.00000	0.00000
.02447	.02447	.86099	.94786	0.00000	0.00000
.20611	.20611	.86099	.94786	0.00000	0.00000
.50000	.50000	.86099	.94786	0.00000	0.00000
.79389	.79389	.86099	.94786	0.00000	0.00000
.97553	.97553	.86099	.94786	0.00000	0.00000
.02447	.02447	.94786	.99409	0.00000	0.00000
.20611	.20611	.94786	.99409	0.00000	0.00000
.50000	.50000	.94786	.99409	0.00000	0.00000
.79389	.79389	.94786	.99409	0.00000	0.00000
.97553	.97553	.94786	.99409	0.00000	0.00000
-1.34225	-1.34225	0.00000	.11084	.34821	.34821
-.96467	-.96467	0.00000	.11084	.34821	.34821
-.43069	-.43069	0.00000	.11084	.34821	.34821
-.05311	-.05311	0.00000	.11084	.34821	.34821
-1.34225	-1.34225	.11084	.22168	.34821	.34821
-.96467	-.96467	.11084	.22168	.34821	.34821
-.43069	-.43069	.11084	.22168	.34821	.34821
-.05311	-.05311	.11084	.22168	.34821	.34821
-1.34225	-1.34225	.22168	.22168	.34821	0.00000
-.96467	-.96467	.22168	.22168	.34821	0.00000
-.43069	-.43069	.22168	.22168	.34821	0.00000
-.05311	-.05311	.22168	.22168	.34821	0.00000
-1.34225	-1.34225	0.00000	.11084	0.00000	0.00000
-.96467	-.96467	0.00000	.11084	0.00000	0.00000
-.43069	-.43069	0.00000	.11084	0.00000	0.00000

-.05311	-.05311	0.00000	.11084	0.00000	0.00000
-1.34225	-1.34225	.11084	.22168	0.00000	0.00000
-.96467	-.96467	.11084	.22168	0.00000	0.00000
-.43069	-.43069	.11084	.22168	0.00000	0.00000
-.05311	-.05311	.11084	.22168	0.00000	0.00000
.02447	.02447	0.00000	.11084	.34821	.34821
.20611	.20611	0.00000	.11084	.34821	.34821
.50000	.50000	0.00000	.11084	.34821	.34821
.79389	.79389	0.00000	.11084	.34821	.34821
.97553	.97553	0.00000	.11084	.34821	.34821
.02447	.02447	.11084	.22168	.34821	.34821
.20611	.20611	.11084	.22168	.34821	.34821
.50000	.50000	.11084	.22168	.34821	.34821
.79389	.79389	.11084	.22168	.34821	.34821
.97553	.97553	.11084	.22168	.34821	.34821
.02447	.02447	.22168	.22168	.34821	0.00000
.20611	.20611	.22168	.22168	.34821	0.00000
.50000	.50000	.22168	.22168	.34821	0.00000
.79389	.79389	.22168	.22168	.34821	0.00000
.97553	.97553	.22168	.22168	.34821	0.00000
.02447	.02447	0.00000	.11084	0.00000	0.00000
.20611	.20611	0.00000	.11084	0.00000	0.00000
.50000	.50000	0.00000	.11084	0.00000	0.00000
.79389	.79389	0.00000	.11084	0.00000	0.00000
.97553	.97553	0.00000	.11084	0.00000	0.00000
.02447	.02447	.11084	.22168	0.00000	0.00000
.20611	.20611	.11084	.22168	0.00000	0.00000
.50000	.50000	.11084	.22168	0.00000	0.00000
.79389	.79389	.11084	.22168	0.00000	0.00000
.97553	.97553	.11084	.22168	0.00000	0.00000
1.03806	1.03806	0.00000	.11084	.34821	.34821
1.30866	1.30866	0.00000	.11084	.34821	.34821
1.69134	1.69134	0.00000	.11084	.34821	.34821
1.96194	1.96194	0.00000	.11084	.34821	.34821
1.03806	1.03806	.11084	.22168	.34821	.34821
1.30866	1.30866	.11084	.22168	.34821	.34821
1.69134	1.69134	.11084	.22168	.34821	.34821
1.96194	1.96194	.11084	.22168	.34821	.34821
1.03806	1.03806	.22168	.22168	.34821	0.00000
1.30866	1.30866	.22168	.22168	.34821	0.00000
1.69134	1.69134	.22168	.22168	.34821	0.00000
1.96194	1.96194	.22168	.22168	.34821	0.00000
1.03806	1.03806	0.00000	.11084	0.00000	0.00000
1.30866	1.30866	0.00000	.11084	0.00000	0.00000
1.69134	1.69134	0.00000	.11084	0.00000	0.00000
1.96194	1.96194	0.00000	.11084	0.00000	0.00000
1.03806	1.03806	.11084	.22168	0.00000	0.00000
1.30866	1.30866	.11084	.22168	0.00000	0.00000
1.69134	1.69134	.11084	.22168	0.00000	0.00000
1.96194	1.96194	.11084	.22168	0.00000	0.00000

CONTROL POINT COORDINATES=

XCP	YCP	ZCP	XCP	YCP	ZCP
.09549	.05542	0.00000	.34549	.05542	0.00000
.65451	.05542	0.00000	.90451	.05542	0.00000
1.00000	.05542	0.00000	.09549	.16626	0.00000
.34549	.16626	0.00000	.65451	.16626	0.00000
.90451	.16626	0.00000	1.00000	.16626	0.00000
.09549	.24514	0.00000	.34549	.24514	0.00000
.65451	.24514	0.00000	.90451	.24514	0.00000
1.00000	.24514	0.00000	.09549	.31272	0.00000
.34549	.31272	0.00000	.65451	.31272	0.00000
.90451	.31272	0.00000	1.00000	.31272	0.00000
.09549	.41626	0.00000	.34549	.41626	0.00000
.65451	.41626	0.00000	.90451	.41626	0.00000
1.00000	.41626	0.00000	.09549	.54326	0.00000
.34549	.54326	0.00000	.65451	.54326	0.00000
.90451	.54326	0.00000	1.00000	.54326	0.00000
.09549	.67842	0.00000	.34549	.67842	0.00000
.65451	.67842	0.00000	.90451	.67842	0.00000
1.00000	.67842	0.00000	.09549	.80542	0.00000
.34549	.80542	0.00000	.65451	.80542	0.00000
.90451	.80542	0.00000	1.00000	.80542	0.00000
.09549	.90895	0.00000	.34549	.90895	0.00000
.65451	.90895	0.00000	.90451	.90895	0.00000
1.00000	.90895	0.00000	.09549	.97653	0.00000
.34549	.97653	0.00000	.65451	.97653	0.00000
.90451	.97653	0.00000	1.00000	.97653	0.00000
-1.19101	.05542	.34821	-.69768	.05542	.34821
-.20435	.05542	.34821	0.00000	.05542	.34821
-1.19101	.16626	.34821	-.69768	.16626	.34821
-.20435	.16626	.34821	0.00000	.16626	.34821
-1.19101	.22168	.17410	-.69768	.22168	.17410
-.20435	.22168	.17410	0.00000	.22168	.17410
-1.19101	.05542	0.00000	-.69768	.05542	0.00000
-.20435	.05542	0.00000	0.00000	.05542	0.00000
-1.19101	.16626	0.00000	-.69768	.16626	0.00000
-.20435	.16626	0.00000	0.00000	.16626	0.00000
.09549	.05542	.34821	.34549	.05542	.34821
.65451	.05542	.34821	.90451	.05542	.34821
1.00000	.05542	.34821	.09549	.16626	.34821
.34549	.16626	.34821	.65451	.16626	.34821
.90451	.16626	.34821	1.00000	.16626	.34821
.09549	.22168	.17410	.34549	.22168	.17410
.65451	.22168	.17410	.90451	.22168	.17410
1.00000	.22168	.17410	.09549	.05542	0.00000
.34549	.05542	0.00000	.65451	.05542	0.00000
.90451	.05542	0.00000	1.00000	.05542	0.00000
.09549	.16626	0.00000	.34549	.16626	0.00000
.65451	.16626	0.00000	.90451	.16626	0.00000

1.00000	.16626	0.00000	1.14645	.05542	.34821
1.50000	.05542	.34821	1.85355	.05542	.34821
2.00000	.05542	.34821	1.14645	.16626	.34821
1.50000	.16626	.34821	1.85355	.16626	.34821
2.00000	.16626	.34821	1.14645	.22168	.17410
1.50000	.22168	.17410	1.85355	.22168	.17410
2.00000	.22168	.17410	1.14645	.05542	0.00000
1.50000	.05542	0.00000	1.85355	.05542	0.00000
2.00000	.05542	0.00000	1.14645	.16626	0.00000
1.50000	.16626	0.00000	1.85355	.16626	0.00000
2.00000	.16626	0.00000			

XX

ALPHA = 6.000 DEGREES

XX

VORTEX	XV	YV	CP	CPW
1	.02447	.05542	4.19144	1.46219
2	.20611	.05542	1.10949	.41118
3	.50000	.05542	.43299	.17943
4	.79389	.05542	.20702	.08080
5	.97553	.05542	.43452	.02380
6	.02447	.16626	2.06471	1.45205
7	.20611	.16626	.78838	.40701
8	.50000	.16626	.27282	.17689
9	.79389	.16626	.07586	.07952
10	.97553	.16626	.41985	.02341
11	.02447	.24514	2.25578	1.43773
12	.20611	.24514	.54247	.40100
13	.50000	.24514	.25654	.17329
14	.79389	.24514	.14245	.07775
15	.97553	.24514	.08023	.02288
16	.02447	.31272	2.04471	1.41836
17	.20611	.31272	.54242	.39279
18	.50000	.31272	.24903	.16845
19	.79389	.31272	.13046	.07539
20	.97553	.31272	.04762	.02220
21	.02447	.41626	1.83521	1.37963
22	.20611	.41626	.51211	.37635
23	.50000	.41626	.22991	.15896
24	.79389	.41626	.11360	.07084
25	.97553	.41626	.03724	.02088
26	.02447	.54326	1.64156	1.31156
27	.20611	.54326	.45673	.34743
28	.50000	.54326	.20091	.14305
29	.79389	.54326	.09626	.06345
30	.97553	.54326	.02989	.01875
31	.02447	.67842	1.44226	1.20253

32	.20611	.67842	.38300	.30144
33	.50000	.67842	.16420	.11988
34	.79389	.67842	.07774	.05315
35	.97553	.67842	.02390	.01585
36	.02447	.80542	1.20880	1.03763
37	.20611	.80542	.29228	.23554
38	.50000	.80542	.12232	.09081
39	.79389	.80542	.05828	.04071
40	.97553	.80542	.01826	.01245
41	.02447	.90895	.50654	.79296
42	.20611	.90895	.18506	.15404
43	.50000	.90895	.07939	.05941
44	.79389	.90895	.03866	.02728
45	.97553	.90895	.01293	.00893
46	.02447	.97653	.49804	.44017
47	.20611	.97653	.08884	.07249
48	.50000	.97653	.03863	.02898
49	.79389	.97653	.01923	.01363
50	.97553	.97653	.00742	.00515

Y/SP	CL	CM	CT	CDI	CLW	CMW	CDW
.05542	.91630	-.21781	.01545	.08077	.32617	-.07136	.01230
.16626	.84377	-.14334	.00185	.05826	.32296	-.07043	.01225
.24514	.48800	-.10981	.08780	-.03700	.31839	-.06912	.01218
.31272	.45449	-.10266	.04390	.00363	.31221	-.06735	.01205
.41626	.41430	-.09323	.03375	.00961	.29997	-.06388	.01180
.54326	.36677	-.08119	.02722	.01118	.27886	-.05804	.01134
.67842	.31155	-.06686	.02135	.01124	.24632	-.04943	.01053
.80542	.24693	-.05061	.01554	.01027	.20082	-.03825	.00924
.90895	.17216	-.03337	.00976	.00828	.14262	-.02550	.00726
.97653	.08870	-.01640	.00491	.00439	.07423	-.01256	.00381

THE LIFT COEFFICIENT = .39681

TOTAL INDUCED DRAG COEFFICIENT = .01854

THE INDUCED DRAG PARAMETER = .11772

TOTAL PITCHING MOMENT COEFFICIENT = -.09077

THE LIFT COEFFICIENT WITH JET ENTRAINMENT ALONE = .28960

THE INDUCED DRAG COEFFICIENT WITH JET ENTRAINMENT ALONE = .00866

THE PITCHING MOMENT COEFFICIENT WITH JET ENTRAINMENT ALONE = -.05961

THE LIFT COEFFICIENT FOR THE WING ALONE = .25238

THE INDUCED DRAG COEFFICIENT FOR THE WING ALONE = .01030

THE PITCHING MOMENT COEFFICIENT FOR THE WING ALONE = -.05255

THE INDUCED DRAG PARAMETER FOR THE WING ALONE = .16169

ERROR SUMMARY

ERROR	TIMES
0115	0151

10.12.10.LS=OWB,T500,CM10000.
10.12.10.E1212 FILLMAN (USPC-F)
10.12.10.USER,274200E.
10.12.10.CHARGE,101429,LRC.
10.12.10.GFT,GLDPL=USF.
10.12.13.UPDATE,0,C,P,I,L=A1234.
10.12.18. UPDATE COMPLETE.
10.12.18.FTN,I,L=L.
10.33.42. 10.336 CP SECONDS COMPILATION TIME
10.33.42.LDSET,PRESET=NGINF,MAP=SF.
10.33.42.L60.
10.33.48. NON-FATAL LOADER ERRORS - SEE MAP
10.33.50. NON-FATAL LOADER ERRORS - SEE MAP
10.40.24. STOP
10.40.24. 18.334 CP SECONDS EXECUTION TIME
10.40.24.LEPF, 0.098KLS.
10.40.24.LEMS, 22.784KLS.
10.40.24.LECP, 30.190SECS.
10.40.24.AESR, 340.347UNTS.

Input Data for the USB Test Case

card	1	2	3	4	5	6	7	8
1	***	USB TEST CASE, SEE TN D-7526						
2		1	1	1				
3	0.	0.	0.1288	1.	6.	-1.968	3.2927	
4		3	2	60.0	60.0	60.0		
5	89.7435	-3.0	1.5	-0.9158	4.8	0.0	0.5	
6	0.0	1.0	1.0	0.11638	0.23277	-0.02532	-0.05064	
7	2.0	62.0	0.0					
8		5	3	3	4	4	4	
9		2	3	4				
10		2	3	2	0	5		
11	-1.968	-0.8276	0.0	-1.968	-0.8681	2.2		
12	-1.968	-0.8681	2.2	-1.968	-0.8921	3.51		
13	-1.968	-0.8921	3.51	-1.968	-0.9396	6.09		
14	-1.968	-0.9396	6.09	-1.968	-1.0429	11.70		
15	-1.968	-1.0429	11.70	-1.968	-1.168	18.50		
16	-0.8276	2.3085	0.0	-0.8681	2.1567	2.2		
17	-0.8681	2.1567	2.2	-0.8921	2.0665	3.51		
18	-0.8921	2.0665	3.51	-0.9396	1.8885	6.09		
19	-0.9396	1.8885	6.09	-1.0429	1.5012	11.70		
20	-1.0429	1.5012	11.7	-1.168	1.032	18.50		
21	2.3085	3.734	0.0	2.1567	3.5316	2.2		
22	2.1567	3.5316	2.2	2.0665	3.4114	3.51		
23	2.0665	3.4114	3.51	1.8885	3.174	6.09		
24	1.8885	3.174	6.09	1.5012	2.6576	11.7		
25	1.5012	2.6576	11.7	1.032	2.032	18.5		
26		4	7	2	3	2	5	
27	-1.968	-0.8921	3.51	0.0				
28	-1.968	-0.8921	3.51	0.6458				
29	-1.968	-0.9396	6.09	0.6458				
30	-1.968	-0.9396	6.09	0.0				
31	-0.8921	2.0665	3.51	0.0				
32	-0.8921	2.0665	3.51	0.6458				
33	-0.9396	1.8885	6.09	0.6458				
34	-0.9396	1.8885	6.09	0.0				
35	2.0665	3.4114	3.51	0.0				
36	2.0665	3.4114	3.51	0.6458				
37	1.8885	3.174	6.09	0.6458				
38	1.8885	3.174	6.09	0.0				
39	3.4114	8.4114	3.51	0.0				
40	3.4114	8.4114	3.51	0.6458				
41	3.174	8.174	6.09	0.6458				
42	3.174	8.174	6.09	0.0				

In addition to the input data listed in the previous page, the root and tip camber slope functions must be inserted manually in subprograms ZCR and ZCT respectively. An alternative to this is to input the camber ordinates with the input data, (see group 11, input data format).

Also, "GAMMA" must be dimensioned in subroutine "SOLUTN". See the prerun check list for determining the size of GAMMA.

Root Camber Function

$$ZCR = 0.0212207 * (-2. * (0.5 - X) * ALOG(ABS(0.5 - X)) + 2. * (1. - X) * ALOG(1. - X) - ALOG(X) - 0.5)$$

Tip Camber Function

$$ZCT = 2. * ZCR(X)$$

GAMMA

DIMENSION AW(300), CA(300), GAMMA(20170)

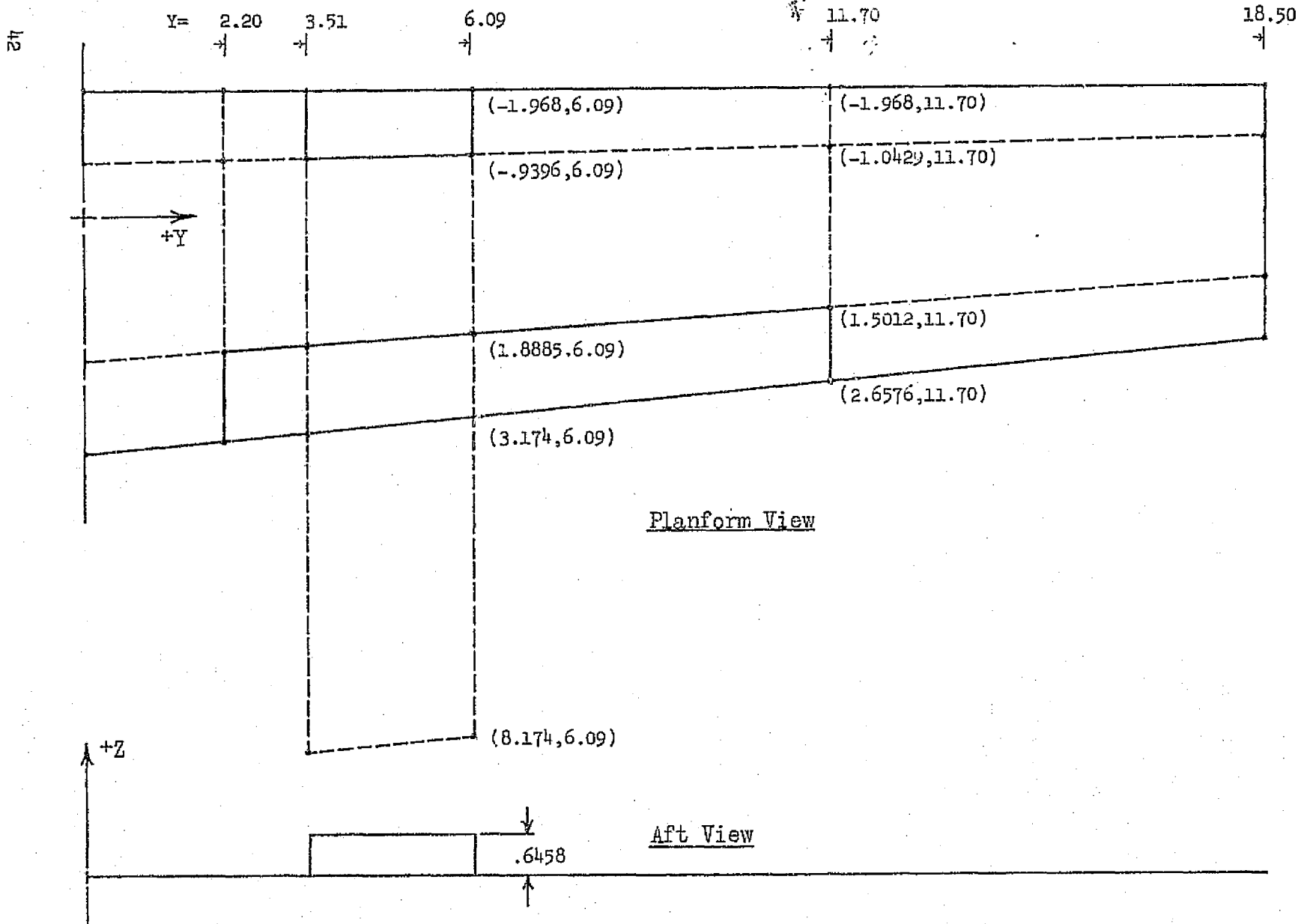

Figure 5 Wing and Jet Sections For The USB Example

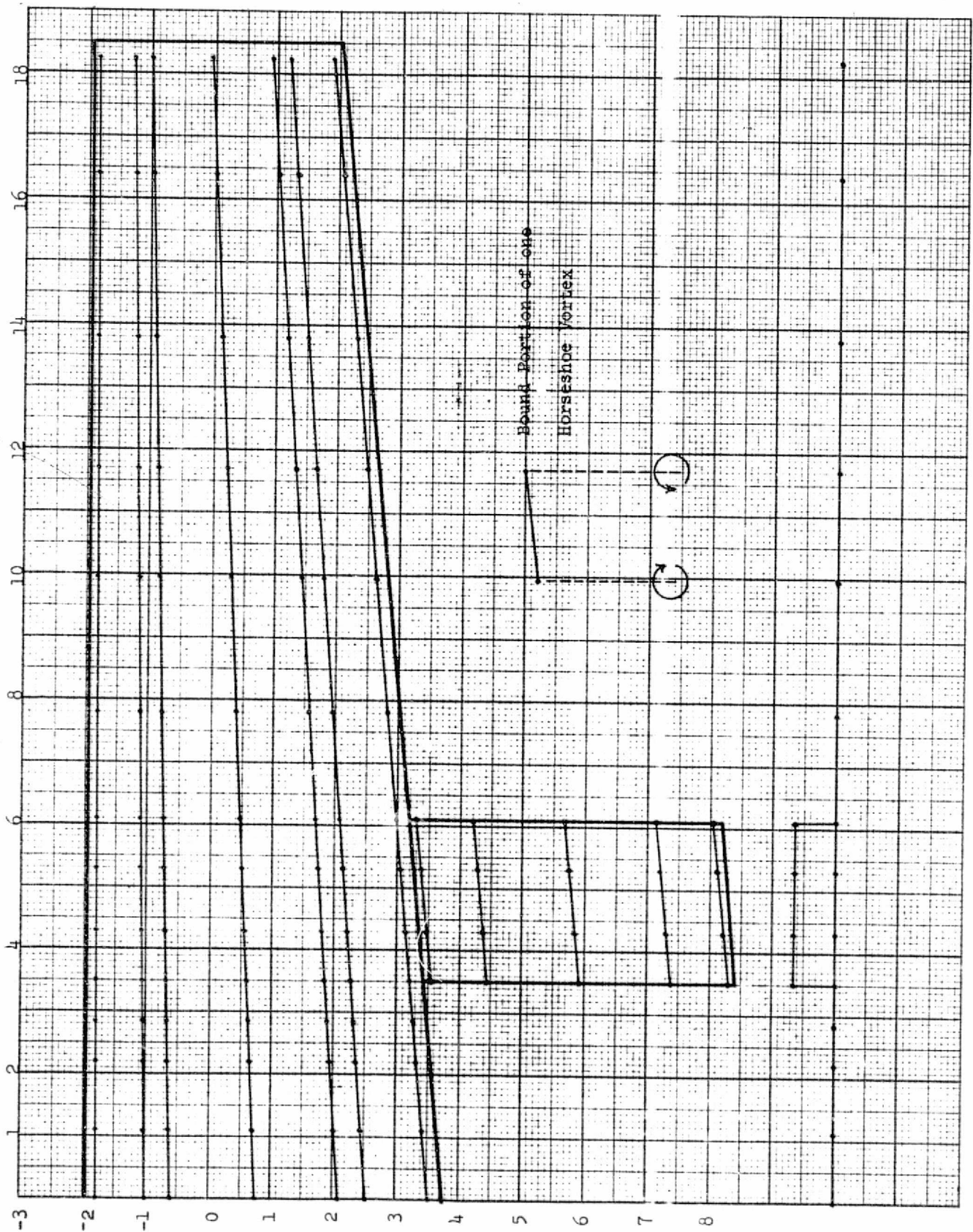

Figure 6 Wing and Jet Vortex Distribution

 *** USE TEST CASE, SFF IN D075Pe

OUTPUT FOR THE USB TEST CASE

1 1 1

XXXXXXXXXXXXXXXXXXXXXXXXXXXX

CASE NUMBER = 1

XXXXXXXXXXXXXXXXXXXXXXXXXXXX

INFLT DATA

0.00000	0.00000	.12800	1.00000	6.00000	-1.56800	3.29270
89.74350	-3.00000	1.50000	60.00000	60.00000	60.00000	.50000
0.00000	1.00000	1.00000	-.91500	4.80000	0.00000	-.05064
2.00000	62.00000	0.00000	.11630	.23277	-.02532	
2	3	3	4	4	4	
2	3	4				
2	3	2	0	0		
-1.96800	-.82760	0.00000	-1.96800	-.86810	2.20000	
-1.96800	-.86810	2.20000	-1.96800	-.89210	3.51000	
-1.96800	-.89210	3.51000	-1.96800	-.93960	6.09000	
-1.96800	-.93960	6.09000	-1.96800	-1.04290	11.70000	
-1.96800	-1.04290	11.70000	-1.96800	-1.16600	18.50000	
-.82760	2.30850	0.00000	-.86810	2.15670	2.20000	
-.86810	2.15670	2.20000	-.89210	2.06650	3.51000	
-.89210	2.06650	3.51000	-.93960	1.88850	6.09000	
-.93960	1.88850	6.09000	-1.04290	1.50120	11.70000	
-1.04290	1.50120	11.70000	-1.16600	1.03200	18.50000	
2.30850	3.73400	0.00000	2.15670	3.53160	2.20000	
2.15670	3.53160	2.20000	2.06650	3.41140	3.51000	
2.06650	3.41140	3.51000	1.88850	3.17400	6.09000	
1.88850	3.17400	6.09000	1.50120	2.65760	11.70000	
1.50120	2.65760	11.70000	1.03200	2.03200	18.50000	
4	7	2	3	2	5	
-1.96800	-.89210	3.51000	0.00000			
-1.96800	-.89210	3.51000	.64500			
-1.96800	-.93960	6.09000	.64500			
-1.96800	-.93960	6.09000	0.00000			
-.89210	2.06650	3.51000	0.00000			
-.89210	2.06650	3.51000	.64500			
-.93960	1.88850	6.09000	.64500			
-.93960	1.88850	6.09000	0.00000			
2.06650	3.41140	3.51000	0.00000			
2.06650	3.41140	3.51000	.64500			
1.88850	3.17400	6.09000	.64500			
1.88850	3.17400	6.09000	0.00000			
3.41140	3.41140	3.51000	0.00000			

44

3.41140 8.41140 3.51000 .64580
 3.17400 8.17400 6.09000 .64580
 3.17400 8.17400 6.09000 0.00000
 HALF SIZE= .P9744E+02 CFFF= .48510E+01

LPANEL= 91 JPANEL= 96 LAST=167 TOTAL=283

VORTEX ELEMENT ENDPOINT COORDINATES=

X1	X2	Y1	Y2	Z1	Z2
-1.80099	-1.80356	0.00000	1.10000	0.00000	0.00000
-.99461	-1.01189	0.00000	1.10000	0.00000	0.00000
-1.80396	-1.80692	1.10000	2.20000	0.00000	0.00000
-1.01189	-1.02918	1.10000	2.20000	0.00000	0.00000
-1.80692	-1.80868	2.20000	2.85500	0.00000	0.00000
-1.02918	-1.03942	2.20000	2.85500	0.00000	0.00000
-1.80868	-1.81044	2.85500	3.51000	0.00000	0.00000
-1.03942	-1.04966	2.85500	3.51000	0.00000	0.00000
-1.81044	-1.81259	3.51000	4.30634	0.00000	0.00000
-1.04966	-1.06218	3.51000	4.30634	0.00000	0.00000
-1.81259	-1.81525	4.30634	5.29366	0.00000	0.00000
-1.06218	-1.07769	4.30634	5.29366	0.00000	0.00000
-1.81525	-1.81739	5.29366	6.09000	0.00000	0.00000
-1.07769	-1.09021	5.29366	6.09000	0.00000	0.00000
-1.81739	-1.82206	6.09000	7.82157	0.00000	0.00000
-1.09021	-1.11742	6.09000	7.82157	0.00000	0.00000
-1.82206	-1.82785	7.82157	9.96843	0.00000	0.00000
-1.11742	-1.15116	7.82157	9.96843	0.00000	0.00000
-1.82785	-1.83252	9.96843	11.70000	0.00000	0.00000
-1.15116	-1.17838	9.96843	11.70000	0.00000	0.00000
-1.83252	-1.83818	11.70000	13.79888	0.00000	0.00000
-1.17838	-1.21134	11.70000	13.79888	0.00000	0.00000
-1.83818	-1.84519	13.79888	16.40112	0.00000	0.00000
-1.21134	-1.25220	13.79888	16.40112	0.00000	0.00000
-1.84519	-1.85015	16.40112	18.74119	0.00000	0.00000
-1.25220	-1.28109	16.40112	18.74119	0.00000	0.00000
-.61752	-.64150	0.00000	1.10000	0.00000	0.00000
.74045	.69237	0.00000	1.10000	0.00000	0.00000
2.09842	2.02625	0.00000	1.10000	0.00000	0.00000
-.64150	-.66548	1.10000	2.20000	0.00000	0.00000
.69237	.64430	1.10000	2.20000	0.00000	0.00000
2.02625	1.95408	1.10000	2.20000	0.00000	0.00000
-.66548	-.67969	2.20000	2.85500	0.00000	0.00000
.64430	.61575	2.20000	2.85500	0.00000	0.00000
1.95408	1.91119	2.20000	2.85500	0.00000	0.00000
-.67969	-.69391	2.85500	3.51000	0.00000	0.00000
.61575	.58720	2.85500	3.51000	0.00000	0.00000
1.91119	1.86831	2.85500	3.51000	0.00000	0.00000
-.69391	-.71127	3.51000	4.30634	0.00000	0.00000
.58720	.55240	3.51000	4.30634	0.00000	0.00000

1.86831	1.81607	3.51000	4.30634	0.00000	0.00000
-.71127	-.73279	4.30634	5.29366	0.00000	0.00000
.55240	.50925	4.30634	5.29366	0.00000	0.00000
1.81607	1.75130	4.30634	5.29366	0.00000	0.00000
-.73279	-.75015	5.29366	6.09000	0.00000	0.00000
.50925	.47445	5.29366	6.09000	0.00000	0.00000
1.75130	1.69905	5.29366	6.09000	0.00000	0.00000
-.75015	-.78791	6.09000	7.82157	0.00000	0.00000
.47445	.39874	6.09000	7.82157	0.00000	0.00000
1.69905	1.58538	6.09000	7.82157	0.00000	0.00000
-.78791	-.83472	7.82157	9.96843	0.00000	0.00000
.39874	.30486	7.82157	9.96843	0.00000	0.00000
1.58538	1.44445	7.82157	9.96843	0.00000	0.00000
-.83472	-.87248	9.96843	11.70000	0.00000	0.00000
.30486	.22915	9.96843	11.70000	0.00000	0.00000
1.44445	1.33078	9.96843	11.70000	0.00000	0.00000
-.87248	-.91821	11.70000	13.79888	0.00000	0.00000
.22915	.13743	11.70000	13.79888	0.00000	0.00000
1.33078	1.19307	11.70000	13.79888	0.00000	0.00000
-.91821	-.97490	13.79888	16.40112	0.00000	0.00000
.13743	.02372	13.79888	16.40112	0.00000	0.00000
1.19307	1.02234	13.79888	16.40112	0.00000	0.00000
-.97490	-1.01499	16.40112	18.24119	0.00000	0.00000
.02372	-.05669	16.40112	18.24119	0.00000	0.00000
1.02234	.90161	16.40112	18.24119	0.00000	0.00000
2.51726	2.43765	0.00000	1.10000	0.00000	0.00000
3.52524	3.42775	0.00000	1.10000	0.00000	0.00000
2.43765	2.35805	1.10000	2.20000	0.00000	0.00000
3.42775	3.33025	1.10000	2.20000	0.00000	0.00000
2.35805	2.31075	2.20000	2.85500	0.00000	0.00000
3.33025	3.27235	2.20000	2.85500	0.00000	0.00000
2.31075	2.26346	2.85500	3.51000	0.00000	0.00000
3.27235	3.21444	2.85500	3.51000	0.00000	0.00000
2.26346	2.20583	3.51000	4.30634	0.00000	0.00000
3.21444	3.14385	3.51000	4.30634	0.00000	0.00000
2.20583	2.13438	4.30634	5.29366	0.00000	0.00000
3.14385	3.05633	4.30634	5.29366	0.00000	0.00000
2.13438	2.07676	5.29366	6.09000	0.00000	0.00000
3.05633	2.98574	5.29366	6.09000	0.00000	0.00000
2.07676	1.95138	6.09000	7.82157	0.00000	0.00000
2.98574	2.83219	6.09000	7.82157	0.00000	0.00000
1.95138	1.79593	7.82157	9.96843	0.00000	0.00000
2.83219	2.64180	7.82157	9.96843	0.00000	0.00000
1.79593	1.67055	9.96843	11.70000	0.00000	0.00000
2.64180	2.48825	9.96843	11.70000	0.00000	0.00000
1.67055	1.51866	11.70000	13.79888	0.00000	0.00000
2.48825	2.30222	11.70000	13.79888	0.00000	0.00000
1.51866	1.33034	13.79888	16.40112	0.00000	0.00000
2.30222	2.07158	13.79888	16.40112	0.00000	0.00000

1.33034	1.19718	16.40112	18.24119	0.00000	0.00000
2.07158	1.90849	16.40112	18.24119	0.00000	0.00000
-1.81044	-1.81044	3.51000	3.51000	0.00000	.64580
-1.04966	-1.04966	3.51000	3.51000	0.00000	.64580
-1.81044	-1.81259	3.51000	4.30634	.64580	.64580
-1.04966	-1.06218	3.51000	4.30634	.64580	.64580
-1.81259	-1.81525	4.30634	5.29366	.64580	.64580
-1.06218	-1.07769	4.30634	5.29366	.64580	.64580
-1.81525	-1.81739	5.29366	6.09000	.64580	.64580
-1.07769	-1.09021	5.29366	6.09000	.64580	.64580
-1.81739	-1.81739	6.09000	6.09000	.64580	0.00000
-1.09021	-1.09021	6.09000	6.09000	.64580	0.00000
-1.81044	-1.81259	3.51000	4.30634	0.00000	0.00000
-1.04966	-1.06218	3.51000	4.30634	0.00000	0.00000
-1.81259	-1.81525	4.30634	5.29366	0.00000	0.00000
-1.06218	-1.07769	4.30634	5.29366	0.00000	0.00000
-1.81525	-1.81739	5.29366	6.09000	0.00000	0.00000
-1.07769	-1.09021	5.29366	6.09000	0.00000	0.00000
-.69391	-.69391	3.51000	3.51000	0.00000	.64580
.58720	.58720	3.51000	3.51000	0.00000	.64580
1.86831	1.86831	3.51000	3.51000	0.00000	.64580
-.69391	-.71127	3.51000	4.30634	.64580	.64580
.58720	.55240	3.51000	4.30634	.64580	.64580
1.86831	1.81607	3.51000	4.30634	.64580	.64580
-.71127	-.73279	4.30634	5.29366	.64580	.64580
.55240	.50925	4.30634	5.29366	.64580	.64580
1.81607	1.75130	4.30634	5.29366	.64580	.64580
-.73279	-.75015	5.29366	6.09000	.64580	.64580
.50925	.47445	5.29366	6.09000	.64580	.64580
1.75130	1.69905	5.29366	6.09000	.64580	.64580
-.75015	-.75015	6.09000	6.09000	.64580	0.00000
.47445	.47445	6.09000	6.09000	.64580	0.00000
1.69905	1.69905	6.09000	6.09000	.64580	0.00000
-.69391	-.71127	3.51000	4.30634	0.00000	0.00000
.58720	.55240	3.51000	4.30634	0.00000	0.00000
1.86831	1.81607	3.51000	4.30634	0.00000	0.00000
-.71127	-.73279	4.30634	5.29366	0.00000	0.00000
.55240	.50925	4.30634	5.29366	0.00000	0.00000
1.81607	1.75130	4.30634	5.29366	0.00000	0.00000
-.73279	-.75015	5.29366	6.09000	0.00000	0.00000
.50925	.47445	5.29366	6.09000	0.00000	0.00000
1.75130	1.69905	5.29366	6.09000	0.00000	0.00000
2.26346	2.26346	3.51000	3.51000	0.00000	.64580
2.21444	2.21444	3.51000	3.51000	0.00000	.64580
2.26346	2.20583	3.51000	4.30634	.64580	.64580
3.21444	3.14385	3.51000	4.30634	.64580	.64580
2.20583	2.13438	4.30634	5.29366	.64580	.64580
3.14385	3.05633	4.30634	5.29366	.64580	.64580
2.13438	2.07676	5.29366	6.09000	.64580	.64580
3.05633	2.98574	5.29366	6.09000	.64580	.64580

REPRODUCIBILITY OF THE
ORIGINAL PAGE IS POOR.

2.07676	2.07676	6.09000	6.09000	.64580	0.00000
2.98574	2.98574	6.09000	6.09000	.64580	0.00000
2.26346	2.20583	3.51000	4.30634	0.00000	0.00000
3.21444	3.14385	3.51000	4.30634	0.00000	0.00000
2.20583	2.13438	4.30634	5.29366	0.00000	0.00000
3.14385	3.05633	4.30634	5.29366	0.00000	0.00000
2.13438	2.07676	5.29366	6.09000	0.00000	0.00000
3.05633	2.98574	5.29366	6.09000	0.00000	0.00000
3.53376	3.53376	3.51000	3.51000	0.00000	.64580
4.44194	4.44194	3.51000	3.51000	0.00000	.64580
5.91140	5.91140	3.51000	3.51000	0.00000	.64580
7.38086	7.38086	3.51000	3.51000	0.00000	.64580
8.28904	8.28904	3.51000	3.51000	0.00000	.64580
3.53376	3.46048	3.51000	4.30634	.64580	.64580
4.44194	4.36866	3.51000	4.30634	.64580	.64580
5.91140	5.83812	3.51000	4.30634	.64580	.64580
7.38086	7.30759	3.51000	4.30634	.64580	.64580
8.28904	8.21577	3.51000	4.30634	.64580	.64580
3.46048	3.36963	4.30634	5.29366	.64580	.64580
4.36866	4.27781	4.30634	5.29366	.64580	.64580
5.83812	5.74728	4.30634	5.29366	.64580	.64580
7.30759	7.21674	4.30634	5.29366	.64580	.64580
8.21577	8.12492	4.30634	5.29366	.64580	.64580
3.36963	3.29636	5.29366	6.09000	.64580	.64580
4.27781	4.20454	5.29366	6.09000	.64580	.64580
5.74728	5.67400	5.29366	6.09000	.64580	.64580
7.21674	7.14346	5.29366	6.09000	.64580	.64580
8.12492	8.05164	5.29366	6.09000	.64580	.64580
3.29636	3.29636	6.09000	6.09000	.64580	0.00000
4.20454	4.20454	6.09000	6.09000	.64580	0.00000
5.67400	5.67400	6.09000	6.09000	.64580	0.00000
7.14346	7.14346	6.09000	6.09000	.64580	0.00000
8.05164	8.05164	6.09000	6.09000	.64580	0.00000
3.53376	3.46048	3.51000	4.30634	0.00000	0.00000
4.44194	4.36866	3.51000	4.30634	0.00000	0.00000
5.91140	5.83812	3.51000	4.30634	0.00000	0.00000
7.38086	7.30759	3.51000	4.30634	0.00000	0.00000
8.28904	8.21577	3.51000	4.30634	0.00000	0.00000
3.46048	3.36963	4.30634	5.29366	0.00000	0.00000
4.36866	4.27781	4.30634	5.29366	0.00000	0.00000
5.83812	5.74728	4.30634	5.29366	0.00000	0.00000
7.30759	7.21674	4.30634	5.29366	0.00000	0.00000
8.21577	8.12492	4.30634	5.29366	0.00000	0.00000
3.36963	3.29636	5.29366	6.09000	0.00000	0.00000
4.27781	4.20454	5.29366	6.09000	0.00000	0.00000
5.74728	5.67400	5.29366	6.09000	0.00000	0.00000
7.21674	7.14346	5.29366	6.09000	0.00000	0.00000
8.12492	8.05164	5.29366	6.09000	0.00000	0.00000

XCP	YCP	ZCP	XCP	YCP	ZCP
-1.40286	.55000	0.00000	-.83772	.55000	0.00000
-1.41299	1.65000	0.00000	-.85797	1.65000	0.00000
-1.42105	2.52750	0.00000	-.87410	2.52750	0.00000
-1.42705	3.18250	0.00000	-.88610	3.18250	0.00000
-1.43353	3.88783	0.00000	-.89906	3.88783	0.00000
-1.44193	4.80000	0.00000	-.91585	4.80000	0.00000
-1.45032	5.71217	0.00000	-.93264	5.71217	0.00000
-1.46136	6.91157	0.00000	-.95473	6.91157	0.00000
-1.47463	8.49500	0.00000	-.98125	8.49500	0.00000
-1.49789	10.87843	0.00000	-1.02777	10.87843	0.00000
-1.51461	12.69584	0.00000	-1.08122	12.69584	0.00000
-1.53673	15.10000	0.00000	-1.10545	15.10000	0.00000
-1.55884	17.50416	0.00000	-1.14968	17.50416	0.00000
-.06086	.55000	0.00000	1.49348	.55000	0.00000
2.27055	.55000	0.00000	-.05482	1.65000	0.00000
1.43149	1.65000	0.00000	2.19465	1.65000	0.00000
-.12204	2.52750	0.00000	1.38209	2.52750	0.00000
2.13415	2.52750	0.00000	-.14231	3.18250	0.00000
1.34526	3.18250	0.00000	2.08905	3.18250	0.00000
-.16418	3.88783	0.00000	1.30556	3.88783	0.00000
2.04043	3.88783	0.00000	-.19251	4.80000	0.00000
1.25416	4.80000	0.00000	1.97750	4.80000	0.00000
-.22084	5.71217	0.00000	1.20276	5.71217	0.00000
1.91457	5.71217	0.00000	-.25810	6.91157	0.00000
1.13515	6.91157	0.00000	1.43178	6.91157	0.00000
-.31973	8.49500	0.00000	1.02332	8.49500	0.00000
1.69485	8.49500	0.00000	-.38135	10.87843	0.00000
.91150	10.87843	0.00000	1.55792	10.87843	0.00000
-.43779	12.69584	0.00000	.80906	12.69584	0.00000
1.43249	12.69584	0.00000	-.51244	15.10000	0.00000
.67359	15.10000	0.00000	1.26660	15.10000	0.00000
-.58708	17.50416	0.00000	.53811	17.50416	0.00000
1.10071	17.50416	0.00000	2.97697	.55000	0.00000
3.68340	.55000	0.00000	2.88842	1.65000	0.00000
3.58220	1.65000	0.00000	2.81785	2.52750	0.00000
3.50155	2.52750	0.00000	2.76525	3.18250	0.00000
3.44145	3.18250	0.00000	2.70853	3.88783	0.00000
3.37662	3.88783	0.00000	2.63510	4.80000	0.00000
3.29270	4.80000	0.00000	2.56167	5.71217	0.00000
3.20877	5.71217	0.00000	2.46508	6.91157	0.00000
3.09237	6.91157	0.00000	2.30532	8.49500	0.00000
2.91580	8.49500	0.00000	2.14557	10.87843	0.00000
2.73323	10.87843	0.00000	1.99924	12.69584	0.00000
2.56558	12.69584	0.00000	1.80570	15.10000	0.00000
2.34480	15.10000	0.00000	1.61216	17.50416	0.00000
2.12362	17.50416	0.00000	-1.43005	3.51000	.32290
-.89210	3.51000	.32290	-1.43352	3.88783	.64580 49

- .89906	3.88783	.64580	-1.44193	4.80000	.64580
- .91585	4.80000	.64580	-1.45032	5.71217	.64580
- .93264	5.71217	.64580	-1.45380	6.09000	.32290
- .93960	6.09000	.32290	-1.43353	3.88783	0.00000
- .89906	3.88783	0.00000	-1.44193	4.80000	0.00000
- .91585	4.80000	0.00000	-1.45032	5.71217	0.00000
- .93264	5.71217	0.00000	- .15248	3.51000	.32290
1.32685	3.51000	.32290	2.06659	3.51000	.32290
- .16418	3.88783	.64580	1.30556	3.88783	.64580
2.04043	3.88783	.64580	- .15251	4.80000	.64580
1.25416	4.80000	.64580	1.97750	4.80000	.64580
- .22084	5.71217	.64580	1.20276	5.71217	.64580
1.91457	5.71217	.64580	- .23258	6.09000	.32290
1.18147	6.09000	.32290	1.88850	6.09000	.32290
- .16418	3.88783	0.00000	1.30556	3.88783	0.00000
2.04043	3.88783	0.00000	- .15251	4.80000	0.00000
1.25416	4.80000	0.00000	1.97750	4.80000	0.00000
- .22084	5.71217	0.00000	1.20276	5.71217	0.00000
1.91457	5.71217	0.00000	2.73895	3.51000	.32290
3.41140	3.51000	.32290	2.70853	3.88783	.64580
3.37663	3.88783	.64580	2.63510	4.80000	.64580
3.29270	4.80000	.64580	2.56167	5.71217	.64580
3.20877	5.71217	.64580	2.53125	6.09000	.32290
3.17400	6.09000	.32290	2.70853	3.88783	0.00000
3.37663	3.88783	0.00000	2.63510	4.80000	0.00000
3.29270	4.80000	0.00000	2.56167	5.71217	0.00000
3.20877	5.71217	0.00000	3.88886	3.51000	.32290
5.13886	3.51000	.32290	6.68394	3.51000	.32290
7.93394	3.51000	.32290	8.41140	3.51000	.32290
3.85409	3.88783	.64580	5.10409	3.88783	.64580
6.64918	3.88783	.64580	7.89918	3.88783	.64580
8.37663	3.88783	.64580	3.77016	4.80000	.64580
5.02016	4.80000	.64580	6.56524	4.80000	.64580
7.81524	4.80000	.64580	8.29270	4.80000	.64580
3.68622	5.71217	.64580	4.53622	5.71217	.64580
6.48131	5.71217	.64580	7.73131	5.71217	.64580
8.20877	5.71217	.64580	3.65146	6.09000	.32290
4.90146	6.09000	.32290	6.44654	6.09000	.32290
7.69654	6.09000	.32290	8.17400	6.09000	.32290
3.85409	3.88783	0.00000	5.10409	3.88783	0.00000
6.64918	3.88783	0.00000	7.89918	3.88783	0.00000
8.37663	3.88783	0.00000	3.77016	4.80000	0.00000
5.02016	4.80000	0.00000	6.56524	4.80000	0.00000
7.81524	4.80000	0.00000	8.29270	4.80000	0.00000
3.68622	5.71217	0.00000	4.53622	5.71217	0.00000
6.48131	5.71217	0.00000	7.73131	5.71217	0.00000
8.20877	5.71217	0.00000			

ALPHA = 6.000 DEGREES

XX

VORTEX	XV	YV	CP	CPW
1	.02929	.02973	6.60437	5.49923
2	.17071	.02973	2.70624	2.25016
3	.23684	.02973	2.50390	2.07023
4	.47500	.02973	2.11562	1.72474
5	.71316	.02973	1.43795	1.13516
6	.78661	.02973	1.23544	.96269
7	.96339	.02973	.51702	.38583
8	.02929	.08919	6.68462	5.57971
9	.17071	.08919	2.77727	2.31434
10	.23684	.08919	2.59084	2.14655
11	.47500	.08919	2.31095	1.89708
12	.71316	.08919	1.42619	1.45924
13	.78661	.08919	1.61229	1.26884
14	.96339	.08919	.67112	.49370
15	.02929	.13662	6.72328	5.66487
16	.17071	.13662	2.85721	2.38557
17	.23684	.13662	2.70322	2.23550
18	.47500	.13662	2.53748	2.14482
19	.71315	.13662	2.65151	3.13625
20	.78661	.13662	3.45475	2.94679
21	.96339	.13662	1.00804	.70294
22	.02929	.17203	6.65214	5.73053
23	.17071	.17203	2.88749	2.44307
24	.23684	.17203	2.90422	2.30725
25	.47500	.17203	2.53914	2.32825
26	.71315	.17203	4.38978	3.61630
27	.78661	.17203	4.17481	3.43437
28	.96339	.17203	1.43257	.84529
29	.02929	.21015	6.07996	5.79260
30	.17071	.21015	2.19241	2.49699
31	.23684	.21015	12.21124	2.37214
32	.47500	.21015	19.54695	2.46926
33	.71315	.21015	40.67512	3.84452
34	.78660	.21015	48.74731	3.66305
35	.96339	.21015	4.39806	.93494
36	.02929	.25946	5.92933	5.84514
37	.17071	.25946	2.13467	2.54851
38	.23684	.25946	20.01870	2.43522
39	.47500	.25946	8.27234	2.58541
40	.71315	.25946	50.35235	3.98349
41	.78661	.25946	49.38227	3.79791
42	.96339	.25946	6.19498	.94448
43	.02929	.30877	6.08179	5.84277
44	.17071	.30877	2.20347	2.56953
45	.23684	.30877	13.85713	2.46377

46	.47500	.30877	20.47784	2.64311
47	.71316	.30877	41.46719	4.04083
48	.78661	.30877	50.31144	3.85207
49	.96339	.30877	4.39419	1.02005
50	.02929	.37360	6.73389	5.80131
51	.17071	.37360	2.99149	2.57599
52	.23684	.37360	2.89131	2.47535
53	.47500	.37360	3.06158	2.67658
54	.71316	.37360	4.52057	4.07568
55	.78661	.37360	4.33262	3.88413
56	.96339	.37360	1.30188	1.03295
57	.02929	.48081	6.30520	5.48266
58	.17071	.48081	2.79371	2.46503
59	.23684	.48081	2.67937	2.37142
60	.47500	.48081	2.85842	2.59476
61	.71316	.48081	4.21195	4.01512
62	.78661	.48081	4.06783	3.83021
63	.96339	.48081	1.09404	1.00688
64	.02929	.58802	5.43348	4.78378
65	.17071	.58802	2.40031	2.15184
66	.23684	.58802	2.27799	2.05068
67	.47500	.58802	2.38237	2.20645
68	.71316	.58802	3.73816	3.62160
69	.78661	.58802	3.57191	3.47033
70	.96339	.58802	.89762	.85108
71	.02929	.68626	4.46906	3.95558
72	.17071	.68626	1.94846	1.75730
73	.23684	.68626	1.79768	1.62528
74	.47500	.68626	1.56693	1.44068
75	.71316	.68626	1.04103	.96176
76	.78661	.68626	.88831	.82025
77	.96339	.68626	.35315	.32284
78	.02929	.81622	3.19487	2.83246
79	.17071	.81622	1.41734	1.28674
80	.23684	.81622	1.28054	1.16449
81	.47500	.81622	1.05876	.97763
82	.71316	.81622	.60300	.55387
83	.78661	.81622	.48642	.44461
84	.96339	.81622	.16454	.14622
85	.02929	.94617	1.73791	1.53112
86	.17071	.94617	.81926	.75179
87	.23684	.94617	.71886	.66075
88	.47500	.94617	.62172	.58337
89	.71316	.94617	.32942	.30612
90	.78661	.94617	.25368	.23371
91	.96339	.94617	.06377	.05474

.08919	2.65245	.02016	.46666	-.19150	2.17343	.03303	-.10209
.13662	2.90923	-.01706	.46947	.37794	2.44845	-.01536	.36721
.17203	3.09351	-.07410	.45987	.54938	2.62242	-.04783	.45631
.21015	16.64215	-3.54391	.42211	8.30734	2.73177	-.05460	.49711
.25946	16.02655	-3.45327	.40332	8.52154	2.81298	-.04756	.51790
.30877	17.34766	-3.29064	.41711	8.51819	2.84611	-.03428	.52505
.37360	3.27163	-.00406	.45766	.53413	2.85875	-.01407	.52897
.48081	3.04138	.04654	.39614	.48745	2.75902	.01537	.53436
.58802	2.61171	.07233	.28913	.46280	2.41046	.04328	.50101
.68626	1.71948	.16855	.19063	-.09179	1.55979	.14666	-.05621
.81622	1.16382	.15599	.09078	-.04179	1.05645	.13860	-.02418
.94617	.65277	.09764	.02181	-.00111	.59655	.08704	.00404

THE LIFT COEFFICIENT = 4.14708

TOTAL INDUCED DRAG COEFFICIENT = 1.35032

THE INDUCED DRAG PARAMETER = .07851

TOTAL PITCHING MOMENT COEFFICIENT = -.43457

THE COANDA LIFT COEFFICIENT, CLP = 1.85437

THE COANDA DRAG COEFFICIENT, CDR = -.49161

THE COANDA MOMENT COEFFICIENT, CMR = -.73879

THE LIFT COEFFICIENT FOR THE WING ALONE = 1.95793

THE INDUCED DRAG COEFFICIENT FOR THE WING ALONE = .23336

THE PITCHING MOMENT COEFFICIENT FOR THE WING ALONE = .04101

THE INDUCED DRAG PARAMETER FOR THE WING ALONE = .06087

10.19.26.USRQW=7500,CM10000.
10.19.26.F1212 FILLMAN (USFCVH)
10.19.26.USFR.274200F.
10.19.26.CHARGE.101429,LRC.
10.19.26.GET.CICPL=USR.
10.24.32.UPDATE,Q,C,P,I,L=A1234.
10.24.36 UPDATE COMPLETE.
10.24.36.FTR,I,L=L.
10.33.40. 10.285 CP SECONDS COMPILEATION TIME
10.33.40.LDSET,PRESSET=NGINF.MAP=SH.
10.33.40.LGO.
10.33.48. NON-FATAL LOADER ERRORS - SET MAP
10.33.51. NON-FATAL LOADER ERRORS - SET MAP
10.52.44. STOP
10.52.44. 61.012 CP SECONDS EXECUTION TIME
10.52.44.LEPF, 0.098KINS.
10.52.44.UFMS, 25.737KINS.
10.52.44.LECP, 72.826SECS.
10.52.44.AESR, 557.039UNTS.

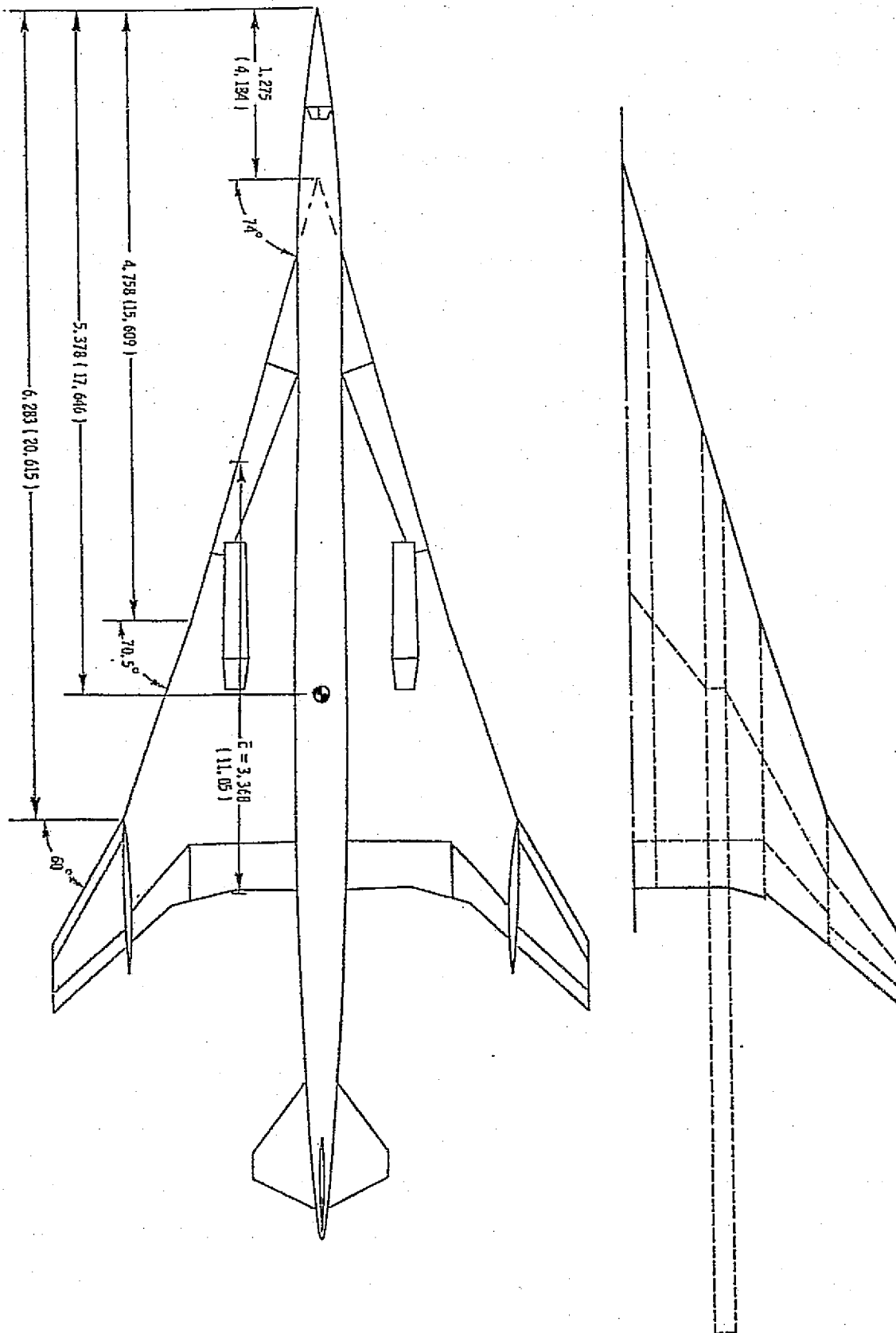

Figure 7 Example Breakdown of a Complicated Geometry Wing

REFERENCES

1. Lan, C. Edward and Campbell, James F.: Theoretical Aerodynamics of Upper-Surface-Blowing Jet-Wing Interaction. NASA TN D-7936, 1975.
2. Lan, C. Edward and Campbell, James F.: A Wing-Jet Interaction Theory for USB Configurations. AIAA Journal of Aircraft, Vol. 13, No. 9, Sept. 1976.
3. Lan, C. Edward: Theoretical Aerodynamics of Over-Wing-Blowing Configurations. NASA CR-144969, 1976.
4. Lan, C. Edward: A Quasi Vortex-Lattice Method in Thin Wing Theory. Journal of Aircraft, Vol. 11, No. 8, August 1974, pp. 491-494.

Computer Program Listing

The following is a listing of the 3,044 separate cards which constitute the computer program.

```

OVERLAY (USBOWB,0,0)
PROGRAM USBOWB(INPUT,OUTPUT,TAPE5=INPUT,TAPE6=OUTPUT,TAPE1,TAPE2) USB 10
C     AERODYNAMICS OF WING-JET INTERACTION USB 20
C     BY C. EDWARD LAN OF THE UNIVERSITY OF KANSAS USB 30
C     USB 40
C     THIS PROGRAM IS APPLICABLE TO BOTH UPPER-SURFACE-BLOWING AND OVER-USB 50
C     WING BLOWING CONFIGURATIONS. USB 60
C     USB 70
C     NOTE. ROOT AND TIP CAMBER FUNCTIONS MAY BE DEFINED AS FUNCTION USB 80
C     SUBPROGRAMS ZCR(X) AND ZCT(X), RESPECTIVELY. USB 90
C     THE ARRAY DIMENSIONS OF THIS PROGRAM RESTRICT THE NUMBER OF WING USB 100
C     VORTICES TO BE 100 MAXIMUM AND THE TOTAL WING AND JET VORTICES TO USB 110
C     200 MAXIMUM. ALSO, CHECK THE ARRAY SIZE OF GAMMA IN SUBROUTINE USB 120
C     "SOLUTN" BEFORE USING THE PROGRAM. USB 130
C     DIMENSION TITLE(13) USB 140
C     COMMON /CODE/ KCODE USB 150
C     COMMON /SCHEME/ C(2),X(10,41),Y(10,41),SLOPE(15),XL(2,15),XTT(41),USB 160
1XLL(41) USB 170
C     COMMON /GEOM/ HALFSW,XCP(200),YCP(200),ZCP(200),XLE(50),YLE(50),XTUSB 180
1E(50),PSI(20),CH(95),XV(200),YV(100),SN(8,8),XN(200,2),YN(200,2),ZUSB 190
2N(200,2),WIDTH(8),YCON(25),SWEEP(50),HALFB,SJ(21,8),EX(95,2),TX(95USB 200
3,2),SC(160,5),SI(160,5),LC(3) USB 210
C     COMMON /AERO/ AM1,AM2,B1,B2,CL(30),CT(30),CD(30),GAM(2,100) USB 220
C     COMMON /CONST/ NCS,NCW,M1(8),NSJ,NCJ(5),LAST,MJW1(3,5),MJW2(3,5),JUSB 230
1PANEL,MJJ(5),NW(3),NNJ,NJP USB 240
C     COMMON /PARAM/ ALPT,ALPC,ALPS,CDF,SDF,TH,TDF USB 250
C     COMMON /JET/ PK1,XC,XJT(31),A(31),B(31) USB 260
C     COMMON /ADD/ CP(100),CM(30),BREAK(8),SWP(8,15),GAL(30),ISYM,VMU,VUUSB 270
1,TEMP,FCR,CAMLER,CAMLET,CAMTER,CAMTET,XJ,YJ,ZJ,RJ,ALP,CREF,TWISTR USB 280
C     COMMON /COST/ LTOTAL,LPAN1,NJW(5),LPANEL,IENTN,LPAN2,EXIT,PTIAL,TWUSB 290
1IST,DF(5),NFP USB 300
C     COMMON /CAMB/ ICAM,IM,XT(2,11),ZC(2,11),AAM(2,10),BBM(2,10),CCM(2,USB 310
110),DDM(2,10) USB 320
C     DIMENSION ISPEC(6) USB 330
C     DATA ISPEC/6*(-0)/ USB 340
C     ISPEC(4)=0 USB 350
C     CALL SYSTEMC (115,ISPEC) USB 360
C     PI=3.14159265 USB 370
C     READ (5,70) (TITLE(I),I=1,13) USB 380
C     *WRITE (6,80) USB 390
C     WRITE (6,70) (TITLE(I),I=1,13) USB 400
C     WRITE (6,80) USB 410
C     NCON=1 USB 420
C     USB 430
C     NUMBER OF CASES TO BE RUN, GEOMETRY CODE (=1 IF GEOMETRY VARIES. USB 440
C     IN THIS CASE, ALPHA MAY ALSO BE DIFFERENT. =0 FOR THE SAME GEOME- USB 450
C     TRY BUT DIFFERENT ALPHA'S) , AND SYMMETRY CODE (=0 FOR A CENTERED USB 460
C     JET, AND=1 OTHERWISE) *** USB 470
C     USB 480

```

	READ (5,60) ICASE,NG,ISYM	USB 490
	WRITE (6,60) ICASE,NG,ISYM	USB 500
10	CONTINUE	USB 510
	WRITE (6,90)	USB 520
	WRITE (6,100) NCON	USB 530
	WRITE (6,90)	USB 540
	CALL OVERLAY (6HUSBOWB,1,0)	USB 550
	CALL OVERLAY (6HUSBOWB,2,0)	USB 560
	CALL OVERLAY (6HUSBOWB,3,0)	USB 570
20	CONTINUE	USB 580
	CALL OVERLAY (6HUSBOWB,4,0)	USB 590
	CALL OVERLAY (6HUSBOWB,5,0)	USB 600
	NCON=NCON+1	USB 610
	IF (NCON.GT.ICASE) GO TO 40	USB 620
	IF (NG.EQ.1) GO TO 10	USB 630
C		USB 640
C	ADDITIONAL ANGLES OF ATTACK IN DEGS. TO BE COMPUTED, TO BE READ IN	USB 650
C	BEHIND THE GEOMETRY DATA DEFINED IN SUBROUTINE "GEOMTY" ***	USB 660
C		USB 670
	READ (5,50) ALP	USB 680
	ALP=ALP*PI/180.	USB 690
	ALPS=SIN(ALP)	USB 700
	ALPC=COS(ALP)	USB 710
	ALPT=ALPS/ALPC	USB 720
	DO 30 I=1,NCS	USB 730
	XLL(I)=ALP+(TWISTR+TWIST*YLE(I)/HALFB)*PI/180.	USB 740
	T=XLL(I)	USB 750
30	XTT(I)=SIN(T)/COS(T)	USB 760
	WRITE (6,90)	USB 770
	WRITE (6,100) NCON	USB 780
	WRITE (6,90)	USB 790
	GO TO 20	USB 800
40	CONTINUE	USB 810
	STOP	USB 820
C		USB 830
50	FORMAT (5F10.5)	USB 840
60	FORMAT (7(6X,I4))	USB 850
70	FORMAT (13A6)	USB 860
80	FORMAT (40H*****))	USB 870
90	FORMAT (1H0,20X,25HXXXXXXXXXXXXXXXXXXXXXXXXXX)	USB 880
100	FORMAT (1H0,25X,13HCASE NUMBER =,I2)	USB 890
	END	USB 900-
	FUNCTION ZCR (X)	ZCR 10
	COMMON /CAMB/ ICAM,IM,XT(2,11),ZC(2,11),AAM(2,10),BBM(2,10),CCM(2,	ZCR 20
	110),DDM(2,10)	ZCR 30
	IF (ICAM.EQ.1) GO TO 10	ZCR 40
C		ZCR 50
C	CAMBER FUNCTION FOR THE ROOT SECTION ***	ZCR 60
C		ZCR 70

```

ZCR=0.0212207*(-2.*(0.5-X)*ALOG(ABS(0.5-X))+2.*(1.-X)*ALOG(1.-X)-AZCR  80
1LOG(X)-0.5) ZCR  90
GO TO 20 ZCR 100
10 ZCR=ZCAM(1,X) ZCR 110
20 RETURN ZCR 120
END ZCR 130-
FUNCTION ZCT (X) ZCT  10
COMMON /CAMB/ ICAM,IM,XT(2,11),ZC(2,11),AAM(2,10),BBM(2,10),CCM(2,ZCT  20
110),DDM(2,10) ZCT  30
IF (ICAM.EQ.1) GO TO 10 ZCT  40
C ZCT  50
C CAMBER FUNCTION FOR THE TIP SECTION *** ZCT  60
C ZCT  70
ZCT=2.*ZCR(X) ZCT  80
GO TO 20 ZCT  90
10 ZCT=ZCAM(2,X) ZCT 100
20 RETURN ZCT 110
END ZCT 120-
FUNCTION ZCAM (I,X) ZCM  10
COMMON /CAMB/ ICAM,IM,XT(2,11),ZC(2,11),AAM(2,10),BBM(2,10),CCM(2,ZCM  20
110),DDM(2,10) ZCM  30
K=1 ZCM  40
10 IF (X.GE.XT(I,K).AND.X.LT.XT(I,K+1)) GO TO 20 ZCM  50
K=K+1 ZCM  60
IF (K.GE.IM) GO TO 30 ZCM  70
GO TO 10 ZCM  80
20 SM=X-XT(I,K) ZCM  90
ZCAM=3.*AAM(I,K)*SM**2+2.*BBM(I,K)*SM+CCM(I,K) ZCM 100
GO TO 50 ZCM 110
30 IF (X.LT.XT(I,1)) GO TO 40 ZCM 120
K=IM-1 ZCM 130
GO TO 20 ZCM 140
40 K=1 ZCM 150
GO TO 20 ZCM 160
50 RETURN ZCM 170
END ZCM 180-
SUBROUTINE VMSEQN (NC1,K,AA,A,CA) VSN  10
C TO SOLVE THE SIMULTANEOUS EQUATIONS BY PURCELL'S VECTOR METHOD VSN  20
DIMENSION AA(1), CA(1), A(1) VSN  30
NC=K*NC1 VSN  40
SUM1=0. VSN  50
K1=K-1 VSN  60
JJ=1 VSN  70
DO 10 J=1,K1 VSN  80
SUM1=SUM1+AA(J)*A(JJ) VSN  90
10 JJ=JJ+NC1+1 VSN 100
SUM1=SUM1+AA(K) VSN 110
DO 30 I=1,NC1 VSN 120
SUM2=0. VSN 130
JJ=I+1 VSN 140

```

	DO 20 J=1,K1	VSN 150
	SUM2=SUM2+AA(J)*A(JJ)	VSN 160
20	JJ=JJ+NC1+1	VSN 170
	KK=K+1	VSN 180
	SUM2=SUM2+AA(KK)	VSN 190
30	CA(I)=-SUM2/SUM1	VSN 200
	M=1	VSN 210
	L=0	VSN 220
	KNC=(K-1)*NC1	VSN 230
	DO 60 I=1,NC	VSN 240
	IF (I.GT.KNC) GO TO 50	VSN 250
	MM=(M-1)*NC1+1	VSN 260
	IF (I.EQ.MM) GO TO 70	VSN 270
40	KK=KK+1	VSN 280
	IL=I+L	VSN 290
	A(I)=CA(KK)*BASE+A(IL)	VSN 300
	GO TO 60	VSN 310
50	II=I-KNC	VSN 320
	A(I)=CA(II)	VSN 330
60	CONTINUE	VSN 340
	GO TO 80	VSN 350
70	II=MM+M-1	VSN 360
	BASE=A(II)	VSN 370
	KK=0	VSN 380
	L=L+1	VSN 390
	M=M+1	VSN 400
	GO TO 40	VSN 410
80	CONTINUE	VSN 420
	RETURN	VSN 430
	END	VSN 440-
	SUBROUTINE INTEG (F,NN,LJ,IZ,IJ,B,IR)	INT 10
C	TO MAKE REFINED INTEGRATION FOR INDUCED TANGENTIAL VELOCITIES	INT 20
	COMMON /GEOM/ HALFSW,XCP(200),YCP(200),ZCP(200),XLE(50),YLE(50),XTINT	30
	1E(50),PSI(20),CH(95),XV(200),YV(100),SN(8,8),XN(200,2),YN(200,2),ZINT	40
	2N(200,2),WIDTH(8),YCON(25),SWEEP(50),HALFB,SJ(21,8),EX(95,2),TX(95	INT 50
	3,2),SC(160,5),SI(160,5),LC(3)	INT 60
	PI=3.14159265	INT 70
	J=LJ+1	INT 80
	JJ=NN*16	INT 90
	IF (NN.GT.6) JJ=NN*8	INT 100
	FJ=JJ	INT 110
	C1=TX(IZ,1)-EX(IZ,1)	INT 120
	C2=TX(IZ,2)-EX(IZ,2)	INT 130
	SUM=0.	INT 140
	DO 10 K=1,JJ	INT 150
	XX1=EX(IZ,1)+C1*SC(K,IR)	INT 160
	XX2=EX(IZ,2)+C2*SC(K,IR)	INT 170
	X1=XX1-XCP(IJ)	INT 180
	X2=XX2-XCP(IJ)	INT 190
	Y1=YN(J,1)-YCP(IJ)	INT 200

	Y2=YN(J,2)-YCP(IJ)	INT 210
	Z1=ZN(J,1)-ZCP(IJ)	INT 220
	Z2=ZN(J,2)-ZCP(IJ)	INT 230
	X12=XX2-XX1	INT 240
	Y12=YN(J,2)-YN(J,1)	INT 250
	Z12=ZN(J,2)-ZN(J,1)	INT 260
	YZI=Y1*Z12-Z1*Y12	INT 270
	XYK=X1*Y12-Y1*X12	INT 280
	XZJ=X1*Z12-Z1*X12	INT 290
	ALB=XYK*XYK+XZJ*XZJ+B*YZI*YZI	INT 300
	R1=SQRT(X1*X1+B*Y1*Y1+B*Z1*Z1)	INT 310
	R2=SQRT(X2*X2+B*Y2*Y2+B*Z2*Z2)	INT 320
	UU=(X2*X12+B*Y2*Y12+B*Z2*Z12)/R2-(X1*X12+B*Y1*Y12+B*Z1*Z12)/R1	INT 330
10	SUM=SUM+UU*YZI/ALB*SI(K,IR)	INT 340
	F=SUM*CH(IZ)/(8.*FJ)	INT 350
	RETURN	INT 360
	END	INT 370-
	OVERLAY(USBOWB,1,0)	
	PROGRAM GEOMTY	GEO 10
C	TO SET UP THE GEOMETRY OF THE VORTEX ELEMENTS AND CONTROL POINTS	GEO 20
	DIMENSION XXL(5), YL(5), XXT(5), ZL(5), CPCWL(31), CPSWL(31)	GEO 30
	COMMON /CODE/ KCODE	GEO 40
	COMMON /SCHEME/ C(4),X(10,41),Y(10,41),SLOPE(15),XL(2,15),XTT(41),	GEO 50
	1XLL(41)	GEO 60
	COMMON /GEOM/ HALFSW,XCP(200),YCP(200),ZCP(200),XLE(50),YLE(50),XTGEO	GEO 70
	1E(50),PSI(20),CH(95),XV(200),YV(100),SN(8,8),XN(200,2),YN(200,2),ZGEO	GEO 80
	2N(200,2),WIDTH(8),YCON(25),SWEEP(50),HALFB,SJ(21,8),EX(95,2),TX(95GEO	GEO 90
	3,2),SC(160,5),SI(160,5),LC(3)	GEO 100
	COMMON /AERO/ AM1,AM2,B1,B2,CL(30),CT(30),CD(30),GAM(2,100)	GEO 110
	COMMON /CONST/ NCS,NCW,M1(8),NSJ,NCJ(5),LAST,MJW1(3,5),MJW2(3,5),JGEO	GEO 120
	1PANEL,MJJ(5),NW(3),NNJ,NJP	GEO 130
	COMMON /PARAM/ ALPT,ALPC,ALPS,CDF,SDF,TH,TDF	GEO 140
	COMMON /ADD/ CP(100),CM(30),BREAK(8),SWP(8,15),GAL(30),ISYM,VMU,VUGEO	GEO 150
	1,TEMP,FCR,CAMLER,CAMLET,CAMTER,CAMTET,XJ,YJ,ZJ,RJ,ALP,CREF,TWISTR	GEO 160
	COMMON /COST/ LTOTAL,LPAN1,NJW(5),LPANEL,IENTN,LPAN2,EXIT,PTIAL,TWGEO	GEO 170
	IIST,DF(5),NFP	GEO 180
	COMMON /CAMB/ ICAM,IM,XT(2,11),ZC(2,11),AAM(2,10),BBM(2,10),CCM(2,GEO	GEO 190
	110),DDM(2,10)	GEO 200
	RT=0.	GEO 210
	WRITE (6,520)	GEO 220
	PI=3.14159265	GEO 230
	NCS=0.	GEO 240
	KL=0	GEO 250
	IPANEL=1	GEO 260
	DO 10 I=1,5	GEO 270
10	DF(I)=0.	GEO 280
C		GEO 290
C	MACH NUMBERS OF FREESTREAM AND JET FLOW, FREESTREAM/JET VELOCITY	GEO 300
C	RATIO,JET/FREESTREAM TEMPERATURE RATIO,ANGLE OF ATTACK IN DEGREE.,	GEO 310

C	WING L.E. AND T.E. X-COORDINATES AT THE JET AXIS LOCATION***	GEO 320
C		GEO 330
	READ (5,470) AM1,AM2,VMU,TEMP,ALP,XEL,XET	GEO 340
	WRITE (6,470) AM1,AM2,VMU,TEMP,ALP,XEL,XET	GEO 350
C		GEO 360
C	NUMBER OF FLAP SECTIONS (INCLUDING THE JET SPAN), THE NUMERICAL	GEO 370
C	ORDER OF JET SPAN AMONG THE FLAP SPANS AND THE CORRESPONDING FLAP	GEO 380
C	DEFLECTION ANGLES IN DEGREES ***	GEO 390
C		GEO 400
	READ (5,510) NFP,NJP,(DF(I),I=1,NFP)	GEO 410
	WRITE (6,510) NFP,NJP,(DF(I),I=1,NFP)	GEO 420
C		GEO 430
C	REFERENCE HALF WING AREA, TWIST IN DEG., INCIDENCE OF ROOT CORD IN	GEO 440
C	DEG., X-, Y- AND Z- COORDINATES OF JET CENTER AT EXIT, AND JET	GEO 450
C	RADIUS ***	GEO 460
C	NOTE. FOR USB APPLICATIONS, YJ,ZJ AND RJ MAY BE ANY NON-ZERO VALUE	GEO 470
C	,UNLESS THE RECTANGULAR JET IS NOT ON THE SURFACE AND THE ENTRAIN-	GEO 480
C	MENT EFFECT IS TO BE ACCOUNTED FOR.	GEO 490
C		GEO 500
	READ (5,470) HALFSW,TWIST,TWISTR,XJ,YJ,ZJ,RJ	GEO 510
	WRITE (6,470) HALFSW,TWIST,TWISTR,XJ,YJ,ZJ,RJ	GEO 520
C		GEO 530
C	TRAILINF-EDGE ANGLE IN DEG., PARTIAL-SPAN FLAP INDICATOR (=0. FOR	GEO 540
C	NO OR FULL-SPAN FLAP, AND =1. OTHERWISE), CONFIGURATION INDICATOR	GEO 550
C	(=1. FOR USB, AND =0. FOR OWB), L.E. CAMBER AT THE ROOT AND TIP,	GEO 560
C	AND T.E. CAMBER AT THE ROOT AND TIP ***	GEO 570
C	NOTE. FOR USB APPLICATIONS, TEANGL MAY BE ANY VALUE *	GEO 580
C		GEO 590
C	IF CAMBER ORDINATES ARE TO BE READ IN, THE L.E. AND T.E. CAMBER	GEO 600
C	SLOPES TO BE READ IN BELOW MAY BE ARBITRARY NUMBERS *	GEO 610
C		GEO 620
	READ (5,470) TEANGL,PTIAL,USB,CAMLER,CAMLET,CAMTER,CAMTET	GEO 630
	WRITE (6,470) TEANGL,PTIAL,USB,CAMLER,CAMLET,CAMTER,CAMTET	GEO 640
	IUSB=USB	GEO 650
	DFJ=0.	GEO 660
	CMU=0.	GEO 670
C		GEO 680
C	THE FOLLOWING DATA ARE NOT NEEDED FOR OWB APPLICATIONS *	GEO 690
	IF (IUSB,NE.1) GO TO 20	GEO 700
C		GEO 710
C	THRUST COEFFICIENT, JET DEFLECTION ANGLE IN DEG. AND ENTRAINMENT	GEO 720
C	CODE IF THE RECTANGULAR JET IS NOT ON THE WING SURFACE (=1. IF THE	GEO 730
C	ENTRAINMENT DUE TO AN EQUIVALENT ROUND JET IS TO BE INCLUDED, =0.	GEO 740
C	OTHERWISE)	GEO 750
C		GEO 760
	READ (5,470) CMU,DFJ,TNJ	GEO 770
	WRITE (6,470) CMU,DFJ,TNJ	GEO 780
20	CONTINUE	GEO 790
	DFJ=DFJ*PI/180.	GEO 800

```

CDF=DFJ
DO 30 I=1,5
30 DF(I)=DF(I)*PI/180.
TDF=DF(NJP)
ALP=ALP*PI/180.
ALPS=SIN(ALP)
ALPC=COS(ALP)
ALPT=ALPS/ALPC
DE=TEANGL*PI/180.+TDF
IF (IUSR.EQ.1) CDF=DFJ
EXIT=0.
IF (XJ.GT.XEL) EXIT=1.
XEL=(XEL-XJ)/RJ
XET=(XET-XJ)/RJ
Z=ZJ/RJ
TH=0.
M1(4)=0
ITN=TNJ
YCON(23)=TNJ
IF (IUSB.EQ.1.AND.ITN.EQ.0) GO TO 40
CALL ENTRN (VMU,AM2,TEMP,XM,CU,RT,XEL,XET,Z,KCODE,XJC)
XEQUI=XM*RJ+XJ
REQUI=RT*RJ
RT=REQUI
IF (IUSB.EQ.1) GO TO 40
IF (XEL.LT.0..AND.ZJ.GE.(2.*RJ)) KCODE=0
IF (ZJ.GE.(3.*RJ)) KCODE=0
F1=-29.5428*CU*CU+33.7371*CU-8.9148
IF (CU.GT.0.6339) F1=0.6+0.4*(CU-0.6339)/0.3661
IF (F1.LT.0..AND.ZJ.GE.(1.9*RJ)) KCODE=0
IF (KCODE.EQ.0) GO TO 40
7R=PI*RT/2.
TH=ZR
40 CONTINUE
IF (IUSB.EQ.1) KCODE=1
IF (IUSB.NE.1.AND.KCODE.EQ.1) GO TO 50
50 AX=XEL*RJ
DJX=2.*RJ
IF (F1.LT.0.) F1=0.
IF (ZJ.LT.(2.*RJ).AND.ZJ.GE.(1.5*RJ)) F1=F1+(1.-F1)*(2.*RJ-ZJ)/(0.
15*RJ)
IF (ZJ.LT.(1.5*RJ)) F1=1.
IF (F1.GT.1.) F1=1.
FACT=F1
CDF=DE*FACT
60 CONTINUE
C
C TOTAL NUMBER OF SPANWISE SECTIONS, AND THE NUMBER OF VORTEX

```

```

GEO 810
GEO 820
GEO 830
GEO 840
GEO 850
GEO 860
GEO 870
GEO 880
GEO 890
GEO 900
GEO 910
GEO 920
GEO 930
GEO 940
GEO 950
GEO 960
GEO 970
GEO 980
GEO 990
GEO1000
GEO1010
GEO1020
GEO1030
GEO1040
GEO1050
GEO1060
GEO1070
GEO1080
GEO1090
GEO1100
GEO1110
GEO1120
GEO1130
GEO1140
GEO1150
GEO1160
GEO1170
GEO1180
GEO1190
GEO1200
GEO1210
GEO1220
GEO1230
GEO1240
GEO1250
GEO1260
GEO1270
GEO1280
GEO1290

```

```

C STRIPS IN EACH SECTION PLUS 1 *** GE01300
C THE NUMBER OF VORTEX STRIPS IN THE JET REGION SHOULD BE CONSISTENT GE01310
C WITH THAT OF JET VORTEX STRIPS * GE01320
C GE01330
C DO 70 I=1,8 GE01340
70 M1(I)=0 GE01350
READ (5,480) NC,(M1(I),I=1,NC) GE01360
WRITE (6,480) NC,(M1(I),I=1,NC) GE01370
C GE01380
C THE NUMERICAL ORDER OF FLAP AND JET SPANS AMONG THE SPANWISE GE01390
C SECTIONS *** GE01400
C GE01410
C READ (5,480) (NJW(I),I=1,NFP) GE01420
C WRITE (6,480) (NJW(I),I=1,NFP) GE01430
C GE01440
C NUMBER OF CHORDWISE VORTEX ELEMENTS IN CHORDWISE SECTIONS, AND GE01450
C CAMBER CODE (=1 IF CAMBER ORDINATES ARE TO BE READ IN, =0 IF GE01460
C CAMBER FUNCTIONS ARE DEFINED BY CLOSED-FORM EXPRESSIONS MANUALLY GE01470
C IN SUBPROGRAMS ZCR(X) AND ZCT(X)). AND THE NUMBER OF CAMBER ORDI- GE01480
C NATES TO BE READ IN (ARBITRARY IF ICAM=0) *** GE01490
C NOTE. THE MAXIMUM NUMBER OF CAMBER ORDINATES ALLOWED IS 11 * GE01500
C GE01510
C READ (5,480) (NW(I),I=1,3),ICAM,IM GE01520
C WRITE (6,480) (NW(I),I=1,3),ICAM,IM GE01530
C NCW=NW(1) GE01540
C L=1 GE01550
C IF (ICAM,NE,1) GO TO 90 GE01560
C GE01570
C IF ICAM=1, READ IN THE X-COORDINATES AND THE CAMBER ORDINATES, GE01580
C FIRST FOR THE ROOT SECTION AND THEN FOR THE TIP SECTION *** GE01590
C GE01600
C DO 80 I=1,2 GE01610
80 READ (5,470) (XT(I,J),J=1,IM) GE01620
READ (5,470) (ZC(I,J),J=1,IM) GE01630
CALL SPLINE (IM,XT,ZC,AAM,BBM,CCM,DDM,1,2) GE01640
90 CONTINUE GE01650
100 CONTINUE GE01660
LL=1 GE01670
FN=NCW GE01680
DO 110 I=1,NCW GE01690
FI=I GE01700
CPCWL(I)=0.5*(1.-COS((2.*FI-1.)*PI/(2.*FN))) GE01710
SN(I,L)=2.*SQRT(CPCWL(I)*(1.-CPCWL(I))) GE01720
110 CPCWL(I)=CPCWL(I)*100. GE01730
DO, 230 KK=1,NC GE01740
C GE01750
C * COORDINATES OF BREAK CHORDS BOUNDING SPANWISE SECTIONS *** GE01760
C GE01770
C READ (5,470) (XXL(I),XXT(I),YL(I),I=1,2) GE01780

```

	WRITE (6,470) (XXL(I),XXT(I),YL(I),I=1,2)	GE01790
	IF (IUSB.EQ.1) GO TO 190	GE01800
	IF (ISYM.EQ.0.AND.KK.EQ.1) GO TO 120	GE01810
	IF (KK.EQ.(NJW(NJP)+1)) GO TO 130	GE01820
	IF (ISYM.NE.0.AND.KK.EQ.(NJW(NJP)-1)) GO TO 140	GE01830
	IF (ISYM.NE.0.AND.KK.EQ.NJW(NJP)) GO TO 120	GE01840
	GO TO 190	GE01850
120	XXL(2)=XXL(1)+(XXL(2)-XXL(1))*(YL(2)-YL(1)+RT-RJ)/(YL(2)-YL(1))	GE01860
	XXT(2)=XXT(1)+(XXT(2)-XXT(1))*(YL(2)-YL(1)+RT-RJ)/(YL(2)-YL(1))	GE01870
	IF (ISYM.EQ.0) GO TO 150	GE01880
130	XXL(1)=XL2	GE01890
	XXT(1)=XT2	GE01900
	GO TO 150	GE01910
140	XXL(2)=XXL(1)+(XXL(2)-XXL(1))*(YL(2)-YL(1)-RT+RJ)/(YL(2)-YL(1))	GE01920
	XXT(2)=XXT(1)+(XXT(2)-XXT(1))*(YL(2)-YL(1)-RT+RJ)/(YL(2)-YL(1))	GE01930
150	XL2=XXL(2)	GE01940
	XT2=XXT(2)	GE01950
	IF (ISYM.EQ.0.AND.KK.EQ.1) GO TO 160	GE01960
	IF (ISYM.NE.0.AND.KK.EQ.(NJW(NJP)-1)) GO TO 160	GE01970
	YL(1)=YL2	GE01980
160	IF (ISYM.EQ.0) GO TO 170	GE01990
	IF (KK.EQ.(NJW(NJP)+1)) GO TO 190	GE02000
	IF (KK.EQ.NJW(NJP)) YL(2)=YL(2)+RT-RJ	GE02010
	IF (KK.EQ.(NJW(NJP)-1)) YL(2)=YL(2)-RT+RJ	GE02020
	GO TO 180	GE02030
170	IF (KK.EQ.1) YL(2)=YL(2)+RT-RJ	GE02040
180	YL2=YL(2)	GE02050
190	CONTINUE	GE02060
	FM=M1(KK)	GE02070
	NSW=M1(KK)	GE02080
	DO 200 J=1,NSW	GE02090
	FJ=J	GE02100
	CPSWL(J)=0.5*(1.-COS((2.*FJ-1.)*PI/(2.*FM)))*100.	GE02110
	YCON(J)=0.5*(1.-COS(FJ*PI/FM))	GE02120
	SJ(J,KK)=SIN(FJ*PI/FM)	GE02130
200	CONTINUE	GE02140
	IF (KK.EQ.NC) GO TO 210	GE02150
	CPSWL(1)=0.	GE02160
	CPSWL(NSW)=100.	GE02170
	GO TO 220	GE02180
210	CPSWL(1)=0.	GE02190
220	IF (KK.EQ.NJW(LL)) MJWI(L,LL)=IPANEL	GE02200
	IF (KK.EQ.NJW(NJP)) LC(L)=KL+1	GE02210
	LR=(L-1)*NC+KK	GE02220
	CALL PANEL (XXL,YL,XXT,CPCWL,CPSWL,NSW,IPANEL,L,PANEL,KL,LR,SWP)	GE02230
	IPANEL=L,PANEL+1	GE02240
	NCS=NCS+NSW-1	GE02250
	WIDTH(KK)=YL(2)-YL(1)	GE02260
	BREAK(KK)=YL(1)	GE02270

	IF (KK.EQ.NJW(LL)) MJW2(L,LL)=LPANEL	GE02280
	IF (KK.NE.NC) GO TO 230	GE02290
	HALFB=YL(2)	GE02300
230	IF (KK.EQ.NJW(LL)) LL=LL+1	GE02310
	IF (L.EQ.3) GO TO 280	GE02320
	IF (L.EQ.1) LPAN1=LPANEL	GE02330
	IF (L.EQ.2) LPAN2=LPANEL	GE02340
	IF (NW(2).EQ.0) GO TO 240	GE02350
	L=L+1	GE02360
	NCW=NW(L)	GE02370
	IF (L.EQ.3.AND.NW(3).EQ.0) GO TO 260	GE02380
	GO TO 100	GE02390
240	DO 250 I=2,3	GE02400
	DO 250 J=1,NFP	GE02410
	MJW1(I,J)=0	GE02420
250	MJW2(I,J)=0	GE02430
	LPAN2=LPANFL	GE02440
	NCS=NCS*3	GE02450
	GO TO 280	GE02460
260	DO 270 I=1,NFP	GE02470
	MJW1(3,I)=0	GE02480
270	MJW2(3,I)=0	GE02490
	L=L-1	GE02500
	NCS=NCS+NCS/2	GE02510
280	CONTINUE	GE02520
	NCS=NCS/3	GE02530
	NCW=NW(1)+NW(2)+NW(3)	GE02540
	VU=VMU	GE02550
	IF (IUSR.EQ.1) CU=VMU	GE02560
	VMU=CU	GE02570
	RTJ=RJ	GE02580
	ZJT=ZJ	GE02590
	IF (RT.GT.ZJ.AND.KCODE.EQ.0) ZJT=RT	GE02600
	IF (IUSR.EQ.1) GO TO 290	GE02610
	AM2=AM1/(VMU*SQRT(TEMP))	GE02620
	IF (AM2.GT.0.9) WRITE (6,560) AM2	GE02630
	IF (AM2.GT.0.9) AM2=0.9	GE02640
290	CONTINUE	GE02650
	LAST=LPANEL	GE02660
C		GE02670
C	TOTAL NUMBER OF STREAMWISE JET SECTIONS, NUMBER OF JET CIRCUM-	GE02680
C	FERENTIAL STRIPS MINUS ONE FOR A NON-CENTERED JET (USE ODD NUMBERS	GE02690
C) AND PLUS ONE FOR A CENTERED JET (USE EVEN NUMBERS), AND NUMBERS	GE02700
C	OF CHORDWISE JET VORTEX ELEMENTS ON EACH JET SECTION ***	GE02710
C		GE02720
	READ (5,480) NNJ,NSJ,(NCJ(I),I=1,NNJ)	GE02730
	WRITE (6,480) NNJ,NSJ,(NCJ(I),I=1,NNJ)	GE02740
	IF (KCODE.EQ.0) CALL CIRCJ (ISYM,NSJ,Y)	GE02750
	IF (ISYM.EQ.0) NSJJ=NSJ/2	GE02760

	IF (ISYM,NE.0) NSJJ=(NSJ+1)/2	GE02770
	NSYM=1-ISYM	GE02780
	NSJI=NSJJ-1	GE02790
	FNJ=NSJJ	GE02800
	CPSWL(1)=0.	GE02810
	CPSWL(NSJJ)=1.	GE02820
	YCON(1)=0.5*(1.-COS(PI/FNJ))	GE02830
	DO 300 I=2,NSJ1	GE02840
	FI=I	GE02850
	CPSWL(I)=0.5*(1.-COS((2.*FI-1.)*PI/(2.*FNJ)))	GE02860
300	YCON(I)=0.5*(1.-COS(FI*PI/FNJ))	GE02870
	IENTN=NC	GE02880
	JC=NCS*L	GE02890
	NJ1=NNJ-1	GE02900
	DO 400 JJ=1,NNJ	GE02910
	IF (IUSB.EQ.1) GO TO 350	GE02920
C		GE02930
C	THIS DATA IS NOT NEEDED FOR USB JOBS **	GE02940
C	* COORDINATES OF ROUNDING LINES OF JET SECTIONS PROJECTED ON X-Y	GE02950
C	PLANE ***	GE02960
C		GE02970
	RFAD (5,470) (XXL(I),XXT(I),YL(I),I=1,2)	GE02980
	WHITE (6,470) (XXL(I),XXT(I),YL(I),I=1,2)	GE02990
	IF (ISYM,EQ.0) GO TO 310	GE03000
	XL1=XXL(1)-(XXL(2)-XXL(1))*(RT-RTJ)/(YL(2)-YL(1))	GE03010
	XT1=XXT(1)-(XXT(2)-XXT(1))*(RT-RTJ)/(YL(2)-YL(1))	GE03020
310	XL2=XXL(1)+(XXL(2)-XXL(1))*(RT+RTJ)/(YL(2)-YL(1))	GE03030
	XT2=XXT(1)+(XXT(2)-XXT(1))*(RT+RTJ)/(YL(2)-YL(1))	GE03040
	IF (ISYM,EQ.0) GO TO 320	GE03050
	XXL(1)=XL1	GE03060
	XXT(1)=XT1	GE03070
320	XXL(2)=XL2	GE03080
	XXT(2)=XT2	GE03090
	IF (ISYM,EQ.0) GO TO 330	GE03100
	YL(1)=YL(1)-RT+RTJ	GE03110
330	YL(2)=YL(2)+RT-RTJ	GE03120
	IF (KCODE,EQ.0) GO TO 340	GE03130
	XXL(4)=XXL(2)	GE03140
	XXT(4)=XXT(2)	GE03150
	YL(4)=YL(2)	GE03160
	XXL(2)=XXL(1)	GE03170
	XXT(2)=XXT(1)	GE03180
	YL(2)=YL(1)	GE03190
	XXL(3)=XXL(4)	GE03200
	XXT(3)=XXT(4)	GE03210
	YL(3)=YL(4)	GE03220
	ZL(1)=0.	GE03230
	ZL(2)=ZR	GE03240
	ZL(3)=ZR	GE03250

	ZL(4)=0.	GE03260
340	CONTINUE	GE03270
	GO TO 370	GE03280
C		GE03290
C	COORDINATES OF BREAK POINTS DEFINING RECTANGULAR JET SECTIONS FOR	GE03300
C	USB CONFIGURATIONS***	GE03310
C		GE03320
350	DO 360 I=1,4	GE03330
	READ (5,470) XXL(I),XXT(I),YL(I),ZL(I)	GE03340
360	WRITE (6,470) XXL(I),XXT(I),YL(I),ZL(I)	GE03350
370	CONTINUE	GE03360
	II=JJ	GE03370
	JJI=JJ+L	GE03380
	FNCJ=NCJ(JJ)	GE03390
	NJ=NCJ(JJ)	GE03400
	NMJ=NJ*16	GE03410
	IF (NJ.GT.6) NMJ=NJ*8	GE03420
	FNJ=NMJ	GE03430
	DO 380 J=1,NMJ	GE03440
	FJ=J	GE03450
	SC(J,JJ)=0.5*(1.-COS((2.*FJ-1.)*PI/(2.*FNJ)))	GE03460
380	SI(J,JJ)=SIN((2.*FJ-1.)*PI/(2.*FNJ))	GE03470
	DO 390 J=1,NJ	GE03480
	FJ=J	GE03490
	CPCWL(J)=0.5*(1.-COS((2.*FJ-1.)*PI/(2.*FNCJ)))	GE03500
390	SN(J,JJ)=2.*SQRT(CPCWL(J)*(1.-CPCWL(J)))	GE03510
	IF (KCODE.EQ.0) CALL JSHAPE (XXL,XXT,YL,YJ,ZJT,RT,CPCWL,IPANEL,NJ,GE03520	
	IJC,ISYM)	GE03530
	IF (KCODE.EQ.1) CALL RESHAP (XXL,XXT,YL,ZL,CPCWL,CPSWL,IPANEL,NJ,GE03540	
	IC,II,NSYM)	GE03550
	MJJ(JJ)=LAST	GE03560
400	IPANEL=LAST+1	GE03570
	SDF=XXT(1)-XXL(1)	GE03580
	IF (IUSB.EQ.1) TH=ZL(3)-ZL(4)	GE03590
	YCON(25)=ZL(4)	GE03600
	YCON(24)=USB	GE03610
	C(1)=CMU	GE03620
	IF (KCODE.EQ.0) YCON(25)=1.	GE03630
	IF (KCODE.EQ.1) CALL RECTJ (ISYM,NSJ,Y)	GE03640
	CREF=HALFSW/HALFR	GE03650
	WRITE (6,490) HALFSW,CREF	GE03660
	JPANEL=LAST-LPANEL	GE03670
	LTOTAL=LAST+JPANEL	GE03680
	WRITE (6,530) LPANEL,JPANEL,LAST,LTOTAL	GE03690
	IF (IUSB.EQ.1) GO TO 410	GE03700
	WRITE (6,650)	GE03710
	IF (KCODE.EQ.0) WRITE (6,670)	GE03720
	IF (KCODE.EQ.1) WRITE (6,680)	GE03730
	IF (KCODE.EQ.1) WRITE (6,690)	GE03740
	WRITE (6,650)	GE03750

	WRITE (6,630) XEQUI	GE03760
	WRITE (6,640) REQUI	GE03770
	WRITE (6,660) VMU	GE03780
410	CONTINUE	GE03790
	IF (ICAM.NE.1) GO TO 420	GE03800
	WRITE (6,570)	GE03810
	WRITE (6,590) (XT(1,I),I=1,IM)	GE03820
	WRITE (6,600) (ZC(1,I),I=1,IM)	GE03830
	WRITE (6,580)	GE03840
	WRITE (6,590) (XT(2,I),I=1,IM)	GE03850
	WRITE (6,600) (ZC(2,I),I=1,IM)	GE03860
	CAMLER=ZCR(0.)	GE03870
	CAMTER=ZCR(1.)	GE03880
	CAMLET=ZCT(0.)	GE03890
	CAMTET=ZCT(1.)	GE03900
420	CONTINUE	GE03910
	WRITE (6,540)	GE03920
	WRITE (6,610)	GE03930
	WRITE (6,500) (XN(I,1),XN(I,2),YN(I,1),YN(I,2),ZN(I,1),ZN(I,2),I=1	GE03940
	1, LAST)	GE03950
	WRITE (6,550)	GE03960
	WRITE (6,620)	GE03970
	WRITE (6,500) (XCP(I),YCP(I),ZCP(I),I=1, LAST)	GE03980
	IF (KCODE.EQ.1) GO TO 440	GE03990
	IF (ISYM.EQ.0) GO TO 430 .	GE04000
	FN2=(NSJ-1)/2+1	GE04010
	NJH=(NSJ-1)/2+2	GE04020
	ANG=PI/(2.*FN2)	GE04030
	FAC=(SIN(3.*ANG)-SIN(ANG)/COS(ANG))/(1.-COS(3.*ANG))	GE04040
	PHI=PI/2.-ATAN(FAC)	GE04050
	NJH1=NJH-1	GE04060
	NJH2=NJH+1	GE04070
	Y(3,2)=SIN(PHI)	GE04080
	Y(4,2)=-COS(PHI)	GE04090
	Y(3,NJH1)=Y(3,2)	GE04100
	Y(4,NJH1)=-Y(4,2)	GE04110
	Y(3,NJH2)=-Y(3,2)	GE04120
	Y(4,NJH2)=Y(4,2)	GE04130
	Y(3,NSJ1)=-Y(3,2)	GE04140
	Y(4,NSJ1)=-Y(4,2)	GE04150
	GO TO 440	GE04160
430	FN2=NSJ/2	GE04170
	NJH=NSJ/2	GE04180
	ANG1=1.-0.5*(1.-COS(PI/(2.*FN2)))	GE04190
	ANG3=1.-0.5*(1.-COS(3.*PI/(2.*FN2)))	GE04200
	ANG1=ATAN(SQRT(1.-ANG1*ANG1)/ANG1)	GE04210
	ANG3=ATAN(SQRT(1.-ANG3*ANG3)/ANG3)	GE04220
	FAC=(SIN(ANG3)-SIN(ANG1)/COS(ANG1))/(1.-COS(ANG3))	GE04230
	PHI=PI/2.-ATAN(FAC)	GE04240
	NJH1=NJH-1	GE04250
	NJH2=NSJ1	GE04260

	Y(3,NJH1)=SIN(PHI)	GE04270
	Y(4,NJH1)=COS(PHI)	GE04280
	Y(3,NJH2)=-Y(3,NJH1)	GE04290
	Y(4,NJH2)=Y(4,NJH1)	GE04300
440	CONTINUE	GE04310
	FNJ=NNJ	GE04320
	DO 450 J=1,NNJ	GE04330
	FJ=J	GE04340
450	PSI(J)=SIN(FJ*PI/FNJ)	GE04350
	BETA1=SQRT(1.-AM1*AM1)	GE04360
	BETA2=SQRT(1.-AM2*AM2)	GE04370
	B1=BETA1*BETA1	GE04380
	B2=BETA2*BETA2	GE04390
	DO 460 KK=1,NCS	GE04400
	XLL(KK)=ALP+(TWISTR+TWIST*YLE(KK)/HALFB)*PI/180.	GE04410
	T=XLL(KK)	GE04420
460	XTT(KK)=SIN(T)/COS(I)	GE04430
	RETURN	GE04440
C		GE04450
470	FORMAT (8(F10.5))	GE04460
480	FORMAT (8(6X,I4))	GE04470
490	FORMAT (10X,8HHALF SW=,E12.5,10X,5HCREF=,E12.5)	GE04480
500	FORMAT (6(F10.5))	GE04490
510	FORMAT (2(6X,I4),10X,5(F10.5))	GE04500
520	FORMAT (1H0,10HINPUT DATA)	GE04510
530	FORMAT (1H0,7HLPANEL=,I3,3X,7HJPANEL=,I3,3X,5HLAST=,I3,3X,7HLTOTAL	GE04520
	I=I3)	GE04530
540	FORMAT (1H0,36HVORTEX ELFMET ENDPOINT COORDINATES=)	GE04540
550	FORMAT (1H0,26HCONTROL POINT COORDINATES=)	GE04550
560	FORMAT (1H0,42HWARNING. THE EQUIVALENT JET MACH NUMBER IS,F10.5,41	GE04560
	IHIT HAS BEEN SET TO 0.9 IN THE COMPUTATION)	GE04570
570	FORMAT (/45H*** CAMBER ORDINATES FOR THE ROOT SECTION **)	GE04580
580	FORMAT (/44H*** CAMBER ORDINATES FOR THE TIP SECTION **)	GE04590
590	FORMAT (/7X,3HX/C,11F10.5)	GE04600
600	FORMAT (/7X,3HZ/C,11F10.5)	GE04610
610	FORMAT (/4X,2HX1,8X,2HX2,8X,2HY1,8X,2HY2,8X,2HZ1,6X,2HZ2)	GE04620
620	FORMAT (/4X,3HXC,7X,3HYCP,7X,3HZCP,7X,3HXC,7X,3HYCP,7X,3HZCP)	GE04630
630	FORMAT (1H0,46HTHE EQUIVALENT JET PROPERTIES ARE EVALUATED AT,F10.	GE04640
	15)	GE04650
640	FORMAT (1H0,28HTHE EQUIVALENT JET RADIUS IS,F10.5)	GE04660
650	FORMAT (/20X,50HXX	GE04670
	1)	GE04680
660	FORMAT (1H0,49HTHE VELOCITY RATIO OF THE EQUIVALENT JET,V0/VJ,IS,F	GE04690
	110.5)	GE04700
670	FORMAT (/20X,38HAN EQUIVALENT CIRCULAR JET IS USED FOR/20X,23HINTE	GE04710
	1RACTION COMPUTATION)	GE04720
680	FORMAT (/20X,43HA RECTANGULAR JET WITH LATERAL EXTENT EQUAL/20X,42	GE04730
	1HTO THE EQUIVALENT JET DIAMETER IS USED FOR/20X,23HINTERACTION COM	GE04740
	2PUTATION)	GE04750
690	FORMAT (/20X,51HNOTE. CHECK WHETHER THE WING IS IMMERSD IN THE JE	GE04760
	1T)	GE04770

	END	GEO4780-
	SUBROUTINE SPLINE (N,X,Y,A,B,C,D,LM,NT)	SPL 10
	DIMENSION S(30), H(12), CA(10), X(2,11), Y(2,11)	SPL 20
	DIMENSION A(2,10), B(2,10), C(2,10), D(2,10)	SPL 30
	L=LM	SPL 40
	DO 90 NN=1,NT	SPL 50
	I=1	SPL 60
	NI=N+1	SPL 70
	NI=N-1	SPL 80
	H(NI)=0.	SPL 90
	H(1)=X(L,3)-X(L,2)	SPL 100
	H(2)=-X(L,3)+X(L,1)	SPL 110
	H(3)=X(L,2)-X(L,1)	SPL 120
	DO 10 K=4,N	SPL 130
10	H(K)=0.	SPL 140
	DO 20 K=1,N	SPL 150
20	S(K)=-H(K+1)/H(1)	SPL 160
	NJ=N-1	SPL 170
	DO 70 I=2,N	SPL 180
	IF (I.EQ.N) GO TO 30	SPL 190
	H(NI)=-6.*((Y(L,I+1)-Y(L,I))/(X(L,I+1)-X(L,I))-(Y(L,I)-Y(L,I-1))/(X(L,I)-X(L,I-1)))	SPL 200
	GO TO 40	SPL 210
30	H(NI)=0.	SPL 220
40	DO 60 J=1,N	SPL 230
	H(J)=0.	SPL 240
	IF (I.EQ.N) GO TO 50	SPL 250
	IF (J.LT.(I-1).OR.J.GT.(I+1)) GO TO 60	SPL 260
	H(I-1)=X(L,I)-X(L,I-1)	SPL 270
	H(I)=2.*(X(L,I+1)-X(L,I-1))	SPL 280
	H(I+1)=X(L,I+1)-X(L,I)	SPL 290
	GO TO 60	SPL 300
50	H(N-2)=X(L,N)-X(L,N-1)	SPL 310
	H(N-1)=-X(L,N)+X(L,N-2)	SPL 320
	H(N)=X(L,N-1)-X(L,N-2)	SPL 330
60	CONTINUE	SPL 340
	II=I	SPL 350
	CALL VMSEGN (NJ,II,H,S,CA)	SPL 360
	NJ=NJ-1	SPL 370
70	CONTINUE	SPL 380
	DO 80 I=1,NI	SPL 390
	A(L,I)=(S(I+1)-S(I))/(6.*(X(L,I+1)-X(L,I)))	SPL 400
	B(L,I)=S(I)/2.	SPL 410
	C(L,I)=(Y(L,I+1)-Y(L,I))/(X(L,I+1)-X(L,I))-(X(L,I+1)-X(L,I))*(2.*S(I)+S(I+1))/6.	SPL 420
	D(L,I)=Y(L,I)	SPL 430
80	L=L+1	SPL 440
90	RETURN	SPL 450
	END	SPL 460
	SUBROUTINE RESHAP (XXL,XXT,YL,ZL,CPCWL,CPSWL,IPANEL,NJ,JC,JJ,NSYM) RES	SPL 470
		SPL 480-
		RES 10

C	TO DEFINE THE LOCATIONS OF VORTEX AND CONTROL POINTS ON RECT.	JETSRES	20
	DIMENSION XXL(1), YL(1), XXT(1), ZL(1), CPCWL(1), CPSWL(1)	RES	30
	COMMON /SCHEME/ C(2), X(10,41), Y(10,41), SLOPE(15), XL(2,15), XTT(41), RES	RES	40
	1XLL(41)	RES	50
	COMMON /GEOM/ HALFSW, XCP(200), YCP(200), ZCP(200), XLE(50), YLE(50), XTRES	RES	60
	1E(50), PSI(20), CH(95), XV(200), YV(100), SN(8,8), XN(200,2), YN(200,2), ZRES	RES	70
	2N(200,2), WIDTH(8), YCON(25), SWEEP(50), HALFB, SJ(21,8), EX(95,2), TX(95RES	RES	80
	3,2), SC(160,5), SI(160,5), LC(3)	RES	90
	COMMON /CONST/ NCS, NCW, M1(8), NSJ, NCJ(5), LAST, MJW1(3,5), MJW2(3,5), JRES	RES	100
	1PANEL, MJJ(5), NW(3), NNJ, NJP	RES	110
	PI=3.14159265	RES	120
	IF (NSYM.EQ.0) NSJJ=(NSJ+1)/2	RES	130
	IF (NSYM.NE.0) NSJJ=NSJ/2	RES	140
	NSJ1=NSJJ-1	RES	150
	DO 10 J=1, NJ	RES	160
	FJ=J	RES	170
	FNJ=NJ	RES	180
10	PSI(J)=0.5*(1.-COS(FJ*PI/FNJ))	RES	190
	DO 170 IS=1,4	RES	200
	IF (NSYM.EQ.1.AND.IS.EQ.1) GO TO 170	RES	210
	IF (IS.EQ.4) GO TO 20	RES	220
	K1=IS	RES	230
	K2=IS+1	RES	240
	GO TO 30	RES	250
20	K1=1	RES	260
	K2=4	RES	270
30	CONTINUE	RES	280
	SPAN=YL(K2)-YL(K1)	RES	290
	XDIF=XXL(K2)-XXL(K1)	RES	300
	DO 40 I=1,2	RES	310
	II=I+K1-1	RES	320
	IF (IS.EQ.4.AND.I.EQ.2) II=4	RES	330
	C(I)=XXT(II)-XXL(II)	RES	340
	DO 40 J=1, NJ	RES	350
40	XL(I,J)=XXL(II)+CPCWL(J)*C(I)	RES	360
	IF (ABS(SPAN).LE.0.001) GO TO 70	RES	370
	DO 50 J=1, NJ	RES	380
50	SLOPE(J)=(XL(2,J)-XL(1,J))/SPAN	RES	390
	DO 60 K=1, NSJJ	RES	400
	YK=CPSWL(K)*SPAN	RES	410
	DO 60 J=1, NJ	RES	420
	Y(J,K)=YK+YL(K1)	RES	430
	X(J,K)=XL(1,J)+SLOPE(J)*(Y(J,K)-YL(K1))	RES	440
60	CONTINUE	RES	450
	NS=NSJ1	RES	460
70	IF (ABS(SPAN).LE.0.001) NS=1	RES	470
	DO 160 K=1, NS	RES	480
	YC=YCON(K)	RES	490
	IF (ABS(SPAN).LE.0.001) YC=0.5	RES	500

	KK=JC+K	RES 510
	CH(KK)=C(1)-(C(1)-C(2))*YC	RES 520
	IF (ABS(SPAN).LE.0.001) GO TO 80	RES 530
	YC1=CPSWL(K)	RES 540
	YC2=CPSWL(K+1)	RES 550
	GO TO 90	RES 560
80	YC1=0.	RES 570
	YC2=1.	RES 580
90	CONTINUE	RES 590
	EX(KK,1)=XXL(K1)+XDIF*YC1	RES 600
	EX(KK,2)=XXL(K1)+XDIF*YC2	RES 610
	TX(KK,1)=XXT(K1)+(XXT(K2)-XXT(K1))*YC1	RES 620
	TX(KK,2)=XXT(K1)+(XXT(K2)-XXT(K1))*YC2	RES 630
	DO 160 J=1,NJ	RES 640
	NPANEL=(K-1)*NJ+J-1+IPANFL	RES 650
	NPAN1=NPANEL-1	RES 660
	DO 130 I=1,2	RES 670
	KI1=K+I-1	RES 680
	IF (ABS(SPAN).LE.0.001) GO TO 100	RES 690
	X1=X(J,KI1)	RES 700
	Y1=Y(J,KI1)	RES 710
	IF (J.NE.1) GO TO 110	RES 720
	Z7=ZL(K1)+(ZL(K2)-ZL(K1))*(Y1-YL(K1))/SPAN	RES 730
	XX=XDIF*(Y1-YL(K1))/SPAN+XXL(K1)	RES 740
	GO TO 120	RES 750
100	IZN=K1	RES 760
	IF (I.EQ.2) IZN=K2	RES 770
	X1=XL(I,J)	RES 780
	Y1=YL(K1)	RES 790
	IF (J.NE.1) GO TO 110	RES 800
	Z7=ZL(IZN)	RES 810
	XX=XXL(IZN)	RES 820
	GO TO 120	RES 830
110	ZZ=ZN(NPAN1,I)	RES 840
	XX=XN(NPAN1,I)	RES 850
120	XN(NPANEL,I)=X1	RES 860
	YN(NPANEL,I)=Y1	RES 870
	ZN(NPANEL,I)=ZZ	RES 880
130	CONTINUE	RES 890
	XD=XDIF*YC+XXL(K1)	RES 900
	XCP(NPANEL)=XD+CH(KK)*PSI(J)	RES 910
	YCP(NPANEL)=YC*SPAN+YL(K1)	RES 920
	IF (ABS(SPAN).LE.0.001) GO TO 140	RES 930
	ZC=ZN(NPANEL,1)+(ZN(NPANEL,1)-ZN(NPANEL,2))*(YCP(NPANEL)-YN(NPANEL,1,1))/(YN(NPANEL,1)-YN(NPANEL,2))	RES 940
	XC=XN(NPANEL,1)+SLOPE(J)*(YCP(NPANEL)-YN(NPANEL,1))	RES 950
	GO TO 150	RES 960
140	ZC=0.5*(ZN(NPANEL,1)+ZN(NPANEL,2))	RES 970
	XC=0.5*(XN(NPANEL,1)+XN(NPANEL,2))	RES 980
		RES 990

150	ZCP(NPANEL)=ZC	RES1000
	XV(NPANEL)=XC	RES1010
160	CONTINUE	RES1020
	IPANEL=NPANEL+1	RES1030
	LAST=NPANEL	RES1040
	JC=KK	RES1050
170	CONTINUE	RES1060
	RETURN	RES1070
	END	RES1080-
	SUBROUTINE PANEL (XXL,YL,XXT,CPCWL,CPSWL,NSW,IPANEL,LPANEL,KK,LR,SPAN	PAN 10
	1WP)	PAN 20
C	TO DEFINE THE LOCATIONS OF VORTEX AND CONTROL POINTS ON THE WING	PAN 30
	DIMENSION XXL(1), YL(1), XXT(1), CPCWL(1), CPSWL(1)	PAN 40
	DIMENSION SWP(8,15)	PAN 50
	COMMON /SCHEME/ C(2),X(10,41),Y(10,41),SLOPE(15),XL(2,15),XTT(41),	PAN 60
	1XLL(41)	PAN 70
	COMMON /GEOM/ HALFSW,XCP(200),YCP(200),ZCP(200),XLE(50),YLE(50),XTPAN	PAN 80
	1E(50),PSI(20),CH(95),XV(200),YV(100),SN(8,8),XN(200,2),YN(200,2),ZPAN	PAN 90
	2N(200,2),WIDTH(R),YCON(25),SWEEP(50),HALFR,SJ(21,8),EX(95,2),TX(95PAN	PAN 100
	3,2),SC(160,5),SI(160,5),LC(3)	PAN 110
	COMMON /CONST/ NCS,NCW,M1(8),NSJ,NCJ(5),LAST,MJW1(3,5),MJW2(3,5),JPAN	PAN 120
	1PANEL,MJJ(5),NW(3),NNJ,NJP	PAN 130
	PI=3.14159265	PAN 140
	NSW1=NSW-1	PAN 150
	DO 10 I=1,2	PAN 160
	C(I)=XXT(I)-XXL(I)	PAN 170
	DO 10 J=1,NCW	PAN 180
10	XL(I,J)=XXL(I)+CPCWL(J)*C(I)/100.	PAN 190
	SPAN=YL(2)-YL(1)	PAN 200
	DO 20 J=1,NCW	PAN 210
	PSI(J)=0.5*(1.-COS(FLOAT(J)*PI/FLOAT(NCW)))	PAN 220
	SLOPE(J)=(XL(2,J)-XL(1,J))/SPAN	PAN 230
20	SWP(J,LR)=ATAN(SLOPE(J))	PAN 240
	DO 30 K=1,NSW	PAN 250
	YK=CPSWL(K)*SPAN/100.	PAN 260
	DO 30 J=1,NCW	PAN 270
	Y(J,K)=YK+YL(1)	PAN 280
	X(J,K)=XL(1,J)+SLOPE(J)*(Y(J,K)-YL(1))	PAN 290
30	CONTINUE	PAN 300
	XLL(1)=XXL(1)	PAN 310
	XTT(1)=XXT(1)	PAN 320
	DO 40 I=2,NSW	PAN 330
	XLL(I)=XLL(I-1)+(XXL(2)-XXL(1))*(Y(1,I)-Y(1,I-1))/SPAN	PAN 340
40	XTT(I)=XTT(I-1)+(XXT(2)-XXT(1))*(Y(1,I)-Y(1,I-1))/SPAN	PAN 350
	DO 60 K=1,NSW1	PAN 360
	KK=NCS+K	PAN 370
	YLE(KK)=YCON(K)*SPAN+YL(1)	PAN 380
	XLE(KK)=XLL(K)+(XLL(K+1)-XLL(K))*(YLE(KK)-Y(1,K))/(Y(1,K+1)-Y(1,K)	PAN 390
	1)	PAN 400

	XTE(KK)=XTT(K)+(XTT(K+1)-XTT(K))*(YLE(KK)-Y(1,K))/(Y(1,K+1)-Y(1,K))	PAN 410
1)		PAN 420
	CH(KK)=XTE(KK)-XLE(KK)	PAN 430
	EX(KK,1)=XXL(1)+(XXL(2)-XXL(1))*CPSWL(K)/100.	PAN 440
	EX(KK,2)=XXL(1)+(XXL(2)-XXL(1))*CPSWL(K+1)/100.	PAN 450
	TX(KK,1)=XXT(1)+(XXT(2)-XXT(1))*CPSWL(K)/100.	PAN 460
	TX(KK,2)=XXT(1)+(XXT(2)-XXT(1))*CPSWL(K+1)/100.	PAN 470
	TANG=(XXL(2)-XXL(1))/SPAN	PAN 480
	SWEEP(KK)=ATAN(TANG)	PAN 490
	DO 60 J=1,NCW	PAN 500
	NPANEL=(K-1)*NCW+J-1+IPANEL	PAN 510
	DO 50 I=1,2	PAN 520
	KI1=K+I-1	PAN 530
	XN(NPANEL,I)=X(J,KI1)	PAN 540
	YN(NPANEL,I)=Y(J,KI1)	PAN 550
	ZN(NPANEL,I)=0.	PAN 560
50	CONTINUE	PAN 570
	XCP(NPANEL)=XLE(KK)+PSI(J)*CH(KK)	PAN 580
	YCP(NPANEL)=YLE(KK)	PAN 590
	ZCP(NPANEL)=0.	PAN 600
	XV(NPANEL)=XLE(KK)+CPCWL(J)*CH(KK)/100.	PAN 610
	YV(NPANEL)=YLE(KK)	PAN 620
60	CONTINUE	PAN 630
	LPANEL=NPANEL	PAN 640
	RETURN	PAN 650
	END	PAN 660
	SUBROUTINE ENTRN (U,AMJ,T,XM,CMU,RT,XEL,XET,Z,KCODE,XJC)	ENT 10
C	TO COMPUTE THE JET ENTRAINMENT FUNCTION	ENT 20
	DIMENSION CSJ(70),SSJ(70)	ENT 30
	DIMENSION PU1(31),PU2(31),FU1(31),FU2(31),FU3(31),RR2(31)	ENT 40
	COMMON /JET/ PK1,XC,X(31),A(31),B(31)	ENT 50
	WRITE (6,260)	ENT 60
	WRITE (6,270)	ENT 70
	PI=3.14159265	ENT 80
	IK=1	ENT 90
	REJ=T	ENT 100
	PK1=0.0185+0.011*U	ENT 110
	KCODE=0	ENT 120
	XMID=0.5*(XEL+XET)	ENT 130
	XM=XMID	ENT 140
	X0=0.	ENT 150
	Q0=1.	ENT 160
	F=2.*PK1*SQRT((1.-U)*REJ)	ENT 170
	XC=0.35/F	ENT 180
	XJC=XC	ENT 190
	P1=1.-U	ENT 200
	UA=(1.+2.*U/(1.-U))/(1.+U/(1.-U))	ENT 210
	X(1)=XC	ENT 220
	DXX=(3.*XET-XEL)/30.	ENT 230

	IOX=DXX	ENT 240
	DXX=IOX	ENT 250
	IF (DXX.GT.3.) GO TO 10	ENT 260
	IF (DXX.GE.1..AND.DXX.LE.3.) DXX=2.5	ENT 270
	IF (DXX.LT.1.) DXX=1.5	ENT 280
10	CONTINUE	ENT 290
	X(2)=X(1)+DXX/2.	ENT 300
	DO 20 I=2,30	ENT 310
20	X(I+1)=X(I)+DXX	ENT 320
	DO 30 I=1,70	ENT 330
	FI=I	ENT 340
	CSJ(I)=COS((2.*FI-1.)*PI/140.)	ENT 350
30	SSJ(I)=SIN((2.*FI-1.)*PI/140.)	ENT 360
	DO 160 I=1,31	ENT 370
	IF (U.LE.0.01) GO TO 80	ENT 380
	IF (I.EQ.1.AND.ABS(T-1.).LE.0.01) GO TO 100	ENT 390
	IF (I.EQ.1) S=(2.*PK1*SQRT(REJ*(1.-U))*XC/0.72-0.35)*SQRT((1.-U)/U	ENT 400
	I*ALOG(UA))	ENT 410
	IF (I.EQ.2) S=DSX*(X(2)-XC)	ENT 420
	IF (I.GT.2) S=SH+DSX*DXX	ENT 430
	M=1	ENT 440
	IF (I.EQ.1) M=2	ENT 450
40	CONTINUE	ENT 460
	SUM=0.	ENT 470
	DO 50 J=1,70	ENT 480
	SB=0.5*S*(1.-CSJ(J))	ENT 490
	AP1=(1.-U)*(1.-EXP(-1./(2.*SB)))	ENT 500
	AG=ALOG((1.+2.*U/AP1)/(1.+U/AP1))	ENT 510
50	SUM=SUM+(1./SQRT(AP1*AG)-SQRT(2.*SB/((1.-U)*0.69314718)))*SSJ(J)	ENT 520
	RES=SUM*PI/70.*0.5*S*SQRT(U)+SQRT(2.*U/(1.-U))*S**1.5/1.0397208	ENT 530
	X1=RES+0.35	ENT 540
	IF (M.NE.1) GO TO 70	ENT 550
	XT=X1/(2.*PK1*SQRT((1.-U)*REJ))	ENT 560
	P1=(1.-U)*(1.-EXP(-1./(2.*S)))	ENT 570
	G1=ALOG((1.+2.*U/P1)/(1.+U/P1))	ENT 580
	DSX=2.*PK1*SQRT(REJ*(1.-U)*P1*G1/U)	ENT 590
	SH=S	ENT 600
	IF (ABS(X(I)-XT).LE.0.01) GO TO 60	ENT 610
	DX=X(I)-XT	ENT 620
	S=S+DX*DSX	ENT 630
	SH=S	ENT 640
	GO TO 40	ENT 650
60	P1=(1.-U)*(1.-EXP(-1./(2.*SH)))	ENT 660
70	IF (ABS(T-1.).LE.0.01) GO TO 100	ENT 670
	XH=X1*0.72/(2.*PK1*SQRT((1.-U)*REJ))	ENT 680
	IF (ABS(X(I)-XH).LE.0.01) GO TO 90	ENT 690
	AK2=(1.-U)*(1.-EXP(-1./(2.*S)))	ENT 700
	AG2=ALOG((1.+2.*U/AK2)/(1.+U/AK2))	ENT 710
	DSX1=2.*PK1/0.72*SQRT(REJ*(1.-U)*AK2*AG2/U)	ENT 720

```

DX=X(I)-XH                                ENT 730
S=S+DX*DSX1                                ENT 740
M=M+1                                        ENT 750
GO TO 40                                    ENT 760
80 IF (I.NE.1) SH=2.*PK1*SQRT(REJ)*X(I)-0.35 ENT 770
IF (I.NE.1) P1=(1.-U)*(1.-EXP(-1./(2.*SH))) ENT 780
DSX=2.*PK1*SQRT(REJ)                        ENT 790
IF (ABS(T-1.).LE.0.01) GO TO 100            ENT 800
S=2.*PK1/0.72*SQRT(REJ)*X(I)-0.35          ENT 810
90 IF (I.EQ.1.AND.U.GT.0.01) DSX=2.*PK1*SQRT(REJ*ALOG(UA)/U)*(1.-U) ENT 820
P1P=-2.*P1*P1/(1.-U)                        ENT 830
H0=1.-EXP(-1./(2.*S))                       ENT 840
H0P=-2.*H0**2/0.72                           ENT 850
P2=(T-1.+0.2*(1.-U*U)*AMJ*AMJ*T)*H0-0.2*P1*AMJ*AMJ*T*(P1+2.*U) ENT 860
P2P=(T-1.+0.2*(1.-U*U)*AMJ*AMJ*T)*H0P-0.2*P1P*AMJ*AMJ*T*(P1+2.*U)-ENT 870
10.2*P1*AMJ*AMJ*T*P1P                        ENT 880
F1P=-P2P*0.8907*(0.08901-0.04005*P2+0.01792*P2**2-0.00646*P2**3)/(ENT 890
11.+1.05001*P2)                               ENT 900
F2P=-P2P*0.79335*(0.0527-0.02886*P2+0.01478*P2**2-0.00589*P2**3)/(ENT 910
11.+1.08869*P2)                               ENT 920
F3P=-P2P*(0.12857-0.04653*P2+0.01820*P2**2-0.00599*P2**3)/(1.+1.02ENT 930
1272*P2)                                       ENT 940
GO TO 110                                    ENT 950
100 P2=0.                                        ENT 960
P2P=0.                                        ENT 970
F1P=0.                                        ENT 980
F2P=0.                                        ENT 990
F3P=0.                                        ENT1000
IF (I.EQ.1.AND.U.GT.0.01) DSX=2.*PK1*SQRT(REJ*ALOG(UA)/U)*(1.-U) ENT1010
110 P1P=-2.*P1*P1/(1.-U)                        ENT1020
F1=0.8907*(0.12857+0.01617*P2-0.00607*P2**2+0.00192*P2**3)/(1.+0.8ENT1030
11817*P2)                                       ENT1040
F2=0.79335*(0.06676+0.00453*P2-0.00204*P2**2+0.00075*P2**3)/(1.+0.ENT1050
185716*P2)                                       ENT1060
F3=(0.21429+0.04061*P2-0.01249*P2**2+0.00351*P2**3)/(1.+0.78948*P2ENT1070
1)                                       ENT1080
FU=U*P1*F1+P1*P1*F2                           ENT1090
DMC1=(P1P*F1+P1*F1P-U*P2P*F3-U*P2*F3P)/FU      ENT1100
DMC2=(P1*F1-U*P2*F3)*(U*P1P*F1+U*P1*F1P+2.*P1*P1P*F2+P1*P1*F2P)/(FENT1110
1U*FU)                                       ENT1120
DMX=2.*(1.-U)*(DMC1-DMC2)*DSX/SQRT(REJ)      ENT1130
RJ2=0.5*(1.-U)/FU                             ENT1140
RJ1=SQRT(RJ2)                                  ENT1150
WRITE (6,250) X(I),RJ1,DMX                    ENT1160
IF (IK.GT.1) GO TO 140                          ENT1170
IF (X(I).GE.XEL) GO TO 120                      ENT1180
GO TO 140                                       ENT1190
120 IF (RJ1.LT.Z) GO TO 140                      ENT1200
XMJ=X0+(Z-R0)*(X(I)-X0)/(RJ1-R0)              ENT1210

```

	IF (XEL.LT.0) GO TO 130	ENT1220
	IF (XMJ.LT.XET) KCODE=1	ENT1230
	IK=IK+1	ENT1240
	GO TO 140	ENT1250
130	XM=0.5*XET	ENT1260
	IF (XMJ.LE.XM) KCODE=1	ENT1270
	IK=IK+1	ENT1280
140	CONTINUE	ENT1290
	R0=RJ1	ENT1300
	X0=X(I)	ENT1310
	PJ1(I)=P1	ENT1320
	PU2(I)=P2	ENT1330
	FU1(I)=F1	ENT1340
	FU2(I)=F2	ENT1350
	FU3(I)=F3	ENT1360
	RR2(I)=RJ2	ENT1370
	IF (I.EQ.1) GO TO 150	ENT1380
	B(I)=(DMX-DMX0)/(X(I+1)-X(I))	ENT1390
	A(I)=DMX0-B(I)*X(I)	ENT1400
	GO TO 160	ENT1410
150	A(I)=0.145*DMX/0.32	ENT1420
	B(I)=(DMX-A(I))/XC	ENT1430
160	DMX0=DMX	ENT1440
	K=1	ENT1450
170	IF (K.GT.30) GO TO 240	ENT1460
	IF (XM.GE.0..AND.XM.LT.XC) GO TO 180	ENT1470
	IF (XM.GE.X(K).AND.XM.LT.X(K+1)) GO TO 180	ENT1480
	K=K+1	ENT1490
	GO TO 170	ENT1500
180	F11=RR2(K)*(PU1(K)*U*FU1(K)+PU1(K)**2*FU2(K))/(U*U)	ENT1510
	F12=RR2(K+1)*(PU1(K+1)*U*FU1(K+1)+PU1(K+1)**2*FU2(K+1))/(U*U)	ENT1520
	F21=RR2(K)*(PU1(K)*FU1(K)-U*PU2(K)*FU3(K))/U	ENT1530
	F22=RR2(K+1)*(PU1(K+1)*FU1(K+1)-U*PU2(K+1)*FU3(K+1))/U	ENT1540
	IF (ABS(T-1.).LE.0.001) GO TO 190	ENT1550
	F31=RR2(K)*(9.*PU1(K)/70.-PU1(K)*FU1(K)+U*PU2(K)*FU3(K))/U	ENT1560
	F32=RR2(K+1)*(9.*PU1(K+1)/70.-PU1(K+1)*FU1(K+1)+U*PU2(K+1)*FU3(K+1))	ENT1570
	1))/U	ENT1580
	X11=F11/(F21+F31)	ENT1590
	X12=F12/(F22+F32)	ENT1600
	GO TO 200	ENT1610
190	F31=0.	ENT1620
	F32=0.	ENT1630
200	CONTINUE	ENT1640
	X1=X(K)	ENT1650
	X2=X(K+1)	ENT1660
	X21=F11/(F21+F31)+F31*(F11/(F21+F31)-1.)/F21	ENT1670
	X22=F12/(F22+F32)+F32*(F12/(F22+F32)-1.)/F22	ENT1680
	X31=2.*F21*(F21+F31)/(F11-F21-F31)	ENT1690

	X31=SQRT(X31)	ENT1700
	X32=2.*F22*(F22+F32)/(F12-F22-F32)	ENT1710
	X32=SQRT(X32)	ENT1720
	IF (XM.GE.0..AND.XM.LT.XC) GO TO 210	ENT1730
	GO TO 220	ENT1740
210	X1=0.	ENT1750
	X2=XC	ENT1760
	X22=X21	ENT1770
	X32=X31	ENT1780
	X21=1./U	ENT1790
	X31=1.	ENT1800
	IF (ABS(T-1.),LE.0.001) GO TO 220	ENT1810
	X12=X11	ENT1820
	X11=1./(T*U)	ENT1830
220	CMU=X21+(XM-X1)*(X22-X21)/(X2-X1)	ENT1840
	RT=X31+(XM-X1)*(X32-X31)/(X2-X1)	ENT1850
	CMU=1./CMU	ENT1860
	IF (ABS(T-1.),LF.0.001) GO TO 230	ENT1870
	RU=X11+(XM-X1)*(X12-X11)/(X2-X1)	ENT1880
	T=1./(CMU*RU)	ENT1890
230	CONTINUE	ENT1900
240	CONTINUE	ENT1910
	RETURN	ENT1920
C		ENT1930
250	FORMAT (9F10.5)	ENT1940
260	FORMAT (/5X,43HTHE COMPUTED JET ENTRAINMENT ARE AS FOLLOWS)	ENT1950
270	FORMAT (/5X,4HXJFT,8X,4HRJET,5X,5HDM/DX)	ENT1960
	END	ENT1970
	SUBROUTINE RECTJ (ISYM,NSJ,Y)	REC 10
C	TO DEFINE THE UNIT NORMAL VECTORS TO THE SURFACE OF RECTANGULAR	REC 20
C	JETS	REC 30
	DIMENSION Y(10,41)	REC 40
	IF (ISYM.EQ.0) GO TO 10	REC 50
	NSJ1=NSJ+1	REC 60
	NJH=(NSJ-1)/2+2	REC 70
	GO TO 20	REC 80
10	NSJ1=NSJ-1	REC 90
	NJH=NSJ/2	REC 100
20	DO 50 I=1,NSJ1	REC 110
	IF (I.EQ.1.AND.ISYM.NE.0) GO TO 30	REC 120
	IF (I.EQ.NJH) GO TO 40	REC 130
	Y(3,I)=1.	REC 140
	Y(4,I)=0.	REC 150
	GO TO 50	REC 160
30	Y(3,I)=0.	REC 170
	Y(4,I)=-1.	REC 180
	GO TO 50	REC 190
40	Y(3,I)=0.	REC 200
	Y(4,I)=1.	REC 210

50	CONTINUE	REC 220
	RETURN	REC 230
	END	REC 240-
	SUBROUTINE CIRCJ (ISYM,NSJ,Y)	CIR 10
C	TO DEFINE THE UNIT NORMAL VECTORS TO THE SURFACE OF CIRCULAR JETS	CIR 20
	DIMENSION Y(10,41)	CIR 30
	PI=3.14159265	CIR 40
	IF (ISYM.EQ.0) GO TO 10	CIR 50
	NSJ1=NSJ+1	CIR 60
	NN=(NSJ-1)/2+1	CIR 70
	FN2=NN	CIR 80
	NJH=NN+1	CIR 90
	Y(1,1)=-SIN(PI/(2.*FN2))	CIR 100
	Y(2,1)=-COS(PI/(2.*FN2))	CIR 110
	GO TO 20	CIR 120
10	Y(1,1)=1.	CIR 130
	Y(2,1)=0.	CIR 140
	NSJ1=NSJ-1	CIR 150
	FN2=NSJ/2	CIR 160
	NJH=NSJ/2	CIR 170
20	CONTINUE	CIR 180
	DO 50 I=1,NSJ1	CIR 190
	K=I	CIR 200
	KI=I	CIR 210
	IF (I.GT.NJH.AND.ISYM.NE.0) K=I-NJH+1	CIR 220
	IF (I.GT.NJH.AND.ISYM.EQ.0) K=I-NJH	CIR 230
	FI=K	CIR 240
	IF (ISYM.NE.0) ANG2=(FI-1.)*PI/FN2	CIR 250
	IF (ISYM.EQ.0) ANG2=FI*PI/FN2	CIR 260
	YP=0.5*(1.-COS(ANG2))	CIR 270
	IF (ISYM.EQ.0) ANG2=PI-ATAN(SQRT(1.-YP*YP)/YP)	CIR 280
	II=I+1	CIR 290
	KK=I	CIR 300
	KII=II	CIR 310
	IF (I.GT.NJH) KK=II-NJH	CIR 320
	FII=KK	CIR 330
	IF (I.LE.NJH.AND.ISYM.EQ.0) FII=KK+1	CIR 340
	ANG1=(2.*FII-1.)*PI/(2.*FN2)	CIR 350
	YP=0.5*(1.-COS(ANG1))	CIR 360
	IF (ANG1.GT.PI) YP=-YP	CIR 370
	IF (ISYM.EQ.0) ANG1=PI-ATAN(SQRT(1.-YP*YP)/YP)	CIR 380
	IF (I.GT.NJH) GO TO 30	CIR 390
	GO TO 40	CIR 400
30	ANG1=-ANG1	CIR 410
	ANG2=-ANG2	CIR 420
40	CONTINUE	CIR 430
	Y(1,KII)=SIN(ANG1)	CIR 440
	Y(2,KII)=-COS(ANG1)	CIR 450
	Y(3,KI)=SIN(ANG2)	CIR 460

	Y(4,KI)=-COS(ANG2)	CIR 470
50	CONTINUE	CIR 480
	RETURN	CIR 490
	END	CIR 500-
	SUBROUTINE JSHAPE (XXL,XXT,YL,YJ,ZJ,RJ,CPCWL,IPANEL,NJ,JC,ISYM)	JSH 10
C	TO DEFINE THE LOCATIONS OF VORTEX AND CONTROL POINTS ON CIRCULAR	JSH 20
C	JETS	JSH 30
	DIMENSION CPCWL(1), XXL(1), XXT(1), YL(1)	JSH 40
	COMMON /SCHFME/ C(2),X(10,41),Y(10,41),SLOPE(15),XL(2,15),XTT(41),JSH	50
	1XLL(41)	JSH 60
	COMMON /GEOM/ HALFSW,XCP(200),YCP(200),ZCP(200),XLE(50),YLE(50),XTJSH	70
	1F(50),PSI(20),CH(95),XV(200),YV(100),SN(8,8),XN(200,2),YN(200,2),ZJSH	80
	2N(200,2),WIDTH(8),YCON(25),SWEEP(50),HALFH,SJ(21,8),EX(95,2),TX(95JSH	90
	3,2),SC(160,5),SI(160,5),LC(3)	JSH 100
	COMMON /CONST/ NCS,NCW,M1(8),NSJ,NCJ(5),LAST,MJW1(3,5),MJW2(3,5),JJSH	110
	1PANEL,MJJ(5),NW(3),NNJ,NJP	JSH 120
	PI=3.14159265	JSH 130
	N1=NSJ+1	JSH 140
	IF (ISYM.EQ.0) N1=NSJ-1	JSH 150
	N2=N1+1	JSH 160
	IF (ISYM.EQ.0) N2=NSJ	JSH 170
	N12=N1/2+2	JSH 180
	IF (ISYM.EQ.0) N12=NSJ/2+1	JSH 190
	DO 10 I=1,2	JSH 200
	C(I)=XXT(I)-XXL(I)	JSH 210
	DO 10 J=1,NJ	JSH 220
10	XL(I,J)=XXL(I)+CPCWL(J)*C(I)	JSH 230
	DO 20 J=1,NJ	JSH 240
	FJ=J	JSH 250
	FNCJ=NJ	JSH 260
	PSI(J)=0.5*(1.-COS(FJ*PI/FNCJ))	JSH 270
20	SLOPE(J)=(XL(2,J)-XL(1,J))/(2.*RJ)	JSH 280
	DO 30 K=1,N2	JSH 290
	YY=Y(2,K)	JSH 300
	IF (ISYM.NE.0.AND.K.EQ.1) YY=-1.	JSH 310
	IF (ISYM.NE.0.AND.K.EQ.2) YY=-1.	JSH 320
	IF (K.EQ.(N12-1).OR.K.EQ.N12) YY=1.	JSH 330
	IF (K.EQ.N2) YY=1.	JSH 340
	XTT(K)=YJ+RJ*YY	JSH 350
	DO 30 J=1,NJ	JSH 360
30	X(J,K)=XL(1,J)+SLOPE(J)*(XTT(K)-YL(1))	JSH 370
	DO 120 K=1,N1	JSH 380
	KK=JC+K	JSH 390
	L=K	JSH 400
	IF (K.EQ.N12) L=1	JSH 410
	EX(KK,1)=XXL(1)+(XXL(2)-XXL(1))*(XTT(L)-YL(1))/(2.*RJ)	JSH 420
	EX(KK,2)=XXL(1)+(XXL(2)-XXL(1))*(XTT(K+1)-YL(1))/(2.*RJ)	JSH 430
	TX(KK,1)=XXT(1)+(XXT(2)-XXT(1))*(XTT(L)-YL(1))/(2.*RJ)	JSH 440
	TX(KK,2)=XXT(1)+(XXT(2)-XXT(1))*(XTT(K+1)-YL(1))/(2.*RJ)	JSH 450
	CH(KK)=C(1)-(C(1)-C(2))*0.5*(1.+Y(4,K))	JSH 460

	GO 120 J=1,NJ	JSH 470
	NPANEL=(K-1)*NJ+J-1+IPANEL	JSH 480
	GO 90 I=1,2	JSH 490
	KI1=K+I-1	JSH 500
	SIGN=1.	JSH 510
	IF (K.EQ.N12.AND.I.EQ.1) KI1=1	JSH 520
	IF (ISYM.EQ.0) GO TO 40	JSH 530
	IF (KI1.EQ.1.OR.KI1.EQ.2) GO TO 60	JSH 540
	GO TO 50	JSH 550
40	IF (K.EQ.N12.AND.KI1.EQ.1) SIGN=-1.	JSH 560
50	CONTINUE	JSH 570
	IF (KI1.EQ.(N12-1).OR.KI1.EQ.N12) GO TO 70	JSH 580
	IF (KI1.EQ.N2) GO TO 70	JSH 590
	YY=Y(2,KI1)	JSH 600
	ZZ=Y(1,KI1)*SIGN	JSH 610
	GO TO 80	JSH 620
60	YY=-1.	JSH 630
	ZZ=-Y(1,KI1)/Y(2,KI1)	JSH 640
	GO TO 80	JSH 650
70	YY=1.	JSH 660
	ZZ=Y(1,KI1)/Y(2,KI1)	JSH 670
80	CONTINUE	JSH 680
	XN(NPANEL,I)=X(J,KI1)	JSH 690
	YN(NPANEL,I)=YJ+PJ*YY	JSH 700
90	ZN(NPANEL,I)=ZJ+PJ*ZZ	JSH 710
	YK=0.5*(1.+Y(4,K))	JSH 720
	IF (ISYM.EQ.0) YK=2.*YK-1.	JSH 730
	XCP(NPANEL)=XXL(1)+(XXL(2)-XXL(1))*YK+PSI(J)*CH(KK)	JSH 740
	IF (ABS(YN(NPANEL,2)-YN(NPANEL,1)).LE.0.0001) GO TO 100	JSH 750
	YCP(NPANEL)=YL(1)+YK*(YL(2)-YL(1))	JSH 760
	ZCP(NPANEL)=ZN(NPANEL,1)+(ZN(NPANEL,2)-ZN(NPANEL,1))*(YCP(NPANEL)-	JSH 770
	YN(NPANEL,1))/(YN(NPANEL,2)-YN(NPANEL,1))	JSH 780
	GO TO 110	JSH 790
100	ZCP(NPANEL)=ZJ	JSH 800
	YCP(NPANEL)=YN(NPANEL,1)	JSH 810
110	CONTINUE	JSH 820
	XV(NPANEL)=XXL(1)+(XXL(2)-XXL(1))*YK+CPCWL(J)*CH(KK)	JSH 830
120	CONTINUE	JSH 840
	JC=JC+NI	JSH 850
	LAST=NPANEL	JSH 860
	RETURN	JSH 870
	END	JSH 880-
	OVERLAY(USROWB,2,0)	
	PROGRAM JETOFF	JOF 10
C	TO SET UP THE JETOFF INFLUENCE COEFFICIENT MATRIX AND COMPUTE THE	JOF 20
C	CAMBER TERMS	JOF 30
	DIMENSION AW(101)	JOF 40
	COMMON /GEOM/ HALFSW,XCP(200),YCP(200),ZCP(200),XLE(50),YLE(50),XTJOF	JOF 50
	IF(50),PSI(20),CH(95),XV(200),YV(100),SN(8,8),XA(200,2),YN(200,2),ZJOF	JOF 60
	ZN(200,2),WIDTH(8),YCON(25),SWEEP(50),HALFH,SJ(21,8),EX(95,2),TX(95)	JOF 70

	3,2),SC(160,5),SI(160,5),LC(3)	JOF 80
	COMMON /AERO/ AM1,AM2,B1,R2,CL(30),CT(30),CD(30),GAM(2,100)	JOF 90
	COMMON /CONST/ NCS,NCW,M1(8),NSJ,NCJ(5),LAST,MJW1(3,5),MJW2(3,5),JJOF	100
	LPANEL,MJJ(5),NW(3),NNJ,NJP	JOF 110
	COMMON /ADD/ CP(100),CM(30),BREAK(8),SWP(8,15),GAL(30),ISYM,VMU,VUJOF	120
	1,TEMP,FCR,CAMLER,CAMLET,CAMTER,CAMTET,XJ,YJ,ZJ,RJ,ALP,CREF,TWISTR	JOF 130
	COMMON /PARAM/ ALPT,ALPC,ALPS,CDF,SDF,TH,TDF	JOF 140
	COMMON /COST/ LTOTAL,LPAN1,NJW(5),LPANEL,IENTN,LPAN2,EXIT,PTIAL,TWJOF	150
	IIST,DF(5),NFP	JOF 160
	HFWIND 01	JOF 170
	J1=LPANEL+1	JOF 180
	M=R1	JOF 190
	IC=1	JOF 200
	MG=NW(1)	JOF 210
	NG=NW(1)	JOF 220
	NC=IENTN	JOF 230
	IG=1	JOF 240
10	CONTINUE	JOF 250
	LL=1	JOF 260
	IF (NW(2).EQ.0) GO TO 30	JOF 270
	IJ=1+NCS	JOF 280
	IF (NW(3).NE.0) GO TO 20	JOF 290
	CHORD=CH(1)+CH(IJ)	JOF 300
	GO TO 40	JOF 310
20	III=IJ+NCS	JOF 320
	CHORD=CH(1)+CH(IJ)+CH(III)	JOF 330
	GO TO 40	JOF 340
30	CHORD=CH(1)	JOF 350
40	CONTINUE	JOF 360
	CALL WING (AW,LPANEL,IJ,B,LPAN1,LPAN2)	JOF 370
	XC=(XCP(1)-XLE(IG))/CHORD	JOF 380
	CAM=ZCR(XC)-(ZCR(XC)-ZCT(XC))*YCP(1)/HALFB	JOF 390
	AW(J1)=-CAM	JOF 400
	WRITE (01) (AW(K),K=1,J1)	JOF 410
	IJ=2	JOF 420
	NJ=LPANEL-1	JOF 430
50	CALL WING (AW,LPANEL,IJ,B,LPAN1,LPAN2)	JOF 440
	IF (NW(2).EQ.0) GO TO 70	JOF 450
	II=IG+NCS	JOF 460
	IF (NW(3).NE.0) GO TO 60	JOF 470
	CHORD=CH(IG)+CH(II)	JOF 480
	CHFL=CH(IG)	JOF 490
	GO TO 80	JOF 500
60	III=II+NCS	JOF 510
	CHORD=CH(IG)+CH(II)+CH(III)	JOF 520
	CHFL=CH(IG)+CH(II)	JOF 530
	GO TO 80	JOF 540
70	CHORD=CH(IG)	JOF 550
	CHFL=CH(IG)	JOF 560

80	CONTINUE	JOF 570
	FCR=CHFL/CHORD	JOF 580
	XC=(XCP(IJ)-XLE(IG))/CHORD	JOF 590
	COM=ABS(XC-FCR)	JOF 600
	FCR1=FCR-0.01	JOF 610
	FCR2=FCR+0.01	JOF 620
	C7=0.	JOF 630
	IF (ABS(1.-XC).LE.0.01) GO TO 90	JOF 640
	ZC1=ZCR(XC)	JOF 650
	ZC2=ZCT(XC)	JOF 660
	C7=ZC1-(ZC1-ZC2)*YCP(IJ)/HALFB	JOF 670
90	CONTINUE	JOF 680
	IF (XC.LT.FCR1) CAM=CZ	JOF 690
	IF (COM.LT.0.001) CAM=CZ-0.5*DF(LL)	JOF 700
	IF (XC.GT.FCR2.AND.ABS(1.-XC).GT.0.01) CAM=-DF(LL)+CZ	JOF 710
	IF (ABS(1.-XC).LE.0.01) CAM=-DF(LL)+CAMTER-(CAMTER-CAMTET)*YCP(IJ)	JOF 720
	1/HALFB	JOF 730
	IF (PTIAL.LE.0.01.AND.XC.GT.FCR1) GO TO 140	JOF 740
	IF (PTIAL.GT.0.01) GO TO 110	JOF 750
100	IF (IJ.NE.MG) GO TO 140	JOF 760
	IF (ABS(XC-1.).LE.0.01) GO TO 120	JOF 770
	JK=1	JOF 780
	IF (NW(3).NE.0.AND.IJ.GT.LPAN1) JK=2	JOF 790
	NCM=IJ+(NCS-IG)*NW(JK)+(IG-1)*NW(JK+1)+1	JOF 800
	XC1=(XCP(NCM)-XLE(IG))/CHORD	JOF 810
	CAM1=ZCR(XC1)-(ZCR(XC1)-ZCT(XC1))*YCP(IJ)/HALFB	JOF 820
	CAM=(CAM+CAM1)/2.	JOF 830
	GO TO 140	JOF 840
110	IF (IJ.GE.MJW1(1,LL).AND.IJ.LE.MJW2(1,LL)) GO TO 130	JOF 850
	IF (IJ.GE.MJW1(2,LL).AND.IJ.LE.MJW2(2,LL)) GO TO 140	JOF 860
	IF (IJ.GE.MJW1(3,LL).AND.IJ.LE.MJW2(3,LL)) GO TO 140	JOF 870
	CAM=CZ	JOF 880
	GO TO 100	JOF 890
120	CAM=CAMTER-(CAMTER-CAMTET)*YCP(IJ)/HALFB	JOF 900
	GO TO 140	JOF 910
130	IF (XC.GT.FCR1) GO TO 140	JOF 920
	GO TO 100	JOF 930
140	CONTINUE	JOF 940
	AW(J1)=-CAM	JOF 950
	WRITE (01) (AW(K),K=1,J1)	JOF 960
	IF (IJ.GE.LPAN1.AND.IJ.LT.LPAN2) NG=NW(2)	JOF 970
	IF (IJ.GE.LPAN2.AND.IJ.LT.LPAN1) NG=NW(3)	JOF 980
	IF (IJ.EQ.MJW2(1,LL).OR.IJ.EQ.MJW2(2,LL)) LL=LL+1	JOF 990
	IF (IJ.EQ.MJW2(3,LL)) LL=LL+1	JOF1000
	IF (LL.GT.NFP) LL=1	JOF1010
	IF (IJ.LT.MG) GO TO 150	JOF1020
	IG=IG+1	JOF1030
	MG=MG+NG	JOF1040
150	IF (IJ.EQ.LPAN1.OR.IJ.EQ.LPAN2) IG=1	JOF1050

	IF (IJ.EQ.LPAN1.OR.IJ.EQ.LPAN2) LL=1	JOF1060
	IJ=IJ+1	JOF1070
	NJ=NJ-1	JOF1080
	IF (IJ.LE.LPANEL) GO TO 50	JOF1090
	IC=IC+1	JOF1100
	R=R2	JOF1110
	IG=1	JOF1120
	NG=NW(1)	JOF1130
	MG=NW(1)	JOF1140
	IF (ABS(R1-R2).LE.0.001) GO TO 160	JOF1150
	IF (IC.LE.2) GO TO 10	JOF1160
160	CONTINUE	JOF1170
	RETURN	JOF1180
C	END	JOF1190
	SUBROUTINE WING (AW,LPANEL,I,RR,LPAN1,LPAN2)	JOF1200-
C	TO COMPUTE THE JET-OFF INFLUENCE COEFFICIENT MATRIX	WNG 10
	DIMENSION AW(1)	WNG 20
	DIMENSION W(2)	WNG 30
	COMMON /GEOM/ HALFSW,XCP(200),YCP(200),ZCP(200),XLE(50),YLE(50),XTWNG	WNG 40
	1E(50),PSI(20),CH(95),XV(200),YV(100),SN(8,8),XN(200,2),YN(200,2),ZWNG	WNG 50
	2N(200,2),WIDTH(8),YCON(25),SWEEP(50),HALFR,SJ(21,8),EX(95,2),TX(95WNG	WNG 60
	3,2),SC(160,5),SI(160,5),LC(3)	WNG 70
	COMMON /AERO/ AM1,AM2,B1,R2,CL(30),CT(30),CD(30),GAM(2,100)	WNG 80
	COMMON /CONST/ NCS,NCW,M1(8),NSJ,NCJ(5),LAST,MJW1(3,5),MJW2(3,5),JWNG	WNG 90
	LPANEL,MJJ(5),NW(3),NNJ,NJP	WNG 100
	IZ=1	WNG 110
	IFF=1	WNG 120
	ISN=1	WNG 130
	NL=NW(1)	WNG 140
	NN=NW(1)	WNG 150
	DO 60 J=1,LPANEL	WNG 160
	MI=J-IFF+1	WNG 170
	FN=NL	WNG 180
	IF (J.GT.LPAN1.AND.J.LE.LPAN2) ISN=2	WNG 190
	IF (J.GT.LPAN2.AND.J.LE.LPANEL) ISN=3	WNG 200
	IF (J.GE.LPAN1.AND.J.LT.LPANEL) GO TO 10	WNG 210
	GO TO 20	WNG 220
10	NL=NW(2)	WNG 230
	IF (J.GE.LPAN2.AND.J.LT.LPANEL) NL=NW(3)	WNG 240
20	CONTINUE	WNG 250
	X1=XN(J,1)-XCP(I)	WNG 260
	X2=XN(J,2)-XCP(I)	WNG 270
	X12=XN(J,2)-XN(J,1)	WNG 280
	Y12=YN(J,2)-YN(J,1)	WNG 290
	DO 50 II=1,2	WNG 300
	IF (II.EQ.1) GO TO 30	WNG 310
	N=1	WNG 320
	GO TO 40	WNG 330
		WNG 340

30	N=2	WNG 350
40	CONTINUE	WNG 360
	YC=(-1.)*N*YCP(I)	WNG 370
	Y1=YN(J,1)-YC	WNG 380
	Y2=YN(J,2)-YC	WNG 390
	XYK=X1*Y12-Y1*X12	WNG 400
	R1=SQRT(X1*X1+BB*Y1*Y1)	WNG 410
	R2=SQRT(X2*X2+BB*Y2*Y2)	WNG 420
	U1=(X12*X2+BB*Y12*Y2)/R2-(X12*X1+BB*Y12*Y1)/R1	WNG 430
	U1=U1/XYK	WNG 440
	U2=(1.-X1/R1)/Y1	WNG 450
	U3=(1.-X2/R2)/Y2	WNG 460
50	4(II)=(U1+U2-U3)*CH(IZ)*SN(MI,ISN)/(8.*FN)	WNG 470
	AW(J)=W(1)+W(2)	WNG 480
	IF (J.LT. NN .OR. J.EQ. LPANEL) GO TO 60	WNG 490
	I7=I7+1	WNG 500
	IFF=NN+1	WNG 510
	NN=NN+NL	WNG 520
60	CONTINUE	WNG 530
	RETURN	WNG 540
C		WNG 550
	FND	WNG 560-
	OVERLAY(USROWB,3,0)	
	PROGRAM JETON	JON 10
C	TO SET UP THE JETON INFLUFNCE COEFFICIENT MATRICES	JON 20
	DIMENSION AW(300)	JON 30
	COMMON /CODE/ KCODF	JON 40
	COMMON /GEOM/ HALFSW,XCP(200),YCP(200),ZCP(200),XLE(50),YLE(50),XTJON	50
	1F(50),PSI(20),CH(95),XV(200),YV(100),SN(8,8),XN(200,2),YN(200,2),ZJON	60
	2N(200,2),WIDTH(8),YCON(25),SWEEP(50),HALFR,SJ(21,8),EX(95,2),TX(95	JON 70
	3,2),SC(160,5),SI(160,5),LC(3)	JON 80
	COMMON /AERO/ AM1,AM2,B1,R2,CL(30),CT(30),CD(30),GAM(2,100)	JON 90
	COMMON /CONST/ NCS,NCW,M1(8),NSJ,NCJ(5),LAST,MJW1(3,5),MJW2(3,5),JJON	100
	LPANEL,MJJ(5),NW(3),NNJ,NJP	JON 110
	COMMON /PARAM/ ALPT,ALPC,ALPS,CDF,SDF,TH,TDF	JON 120
	COMMON /ADD/ CP(100),CM(30),BRFAK(8),SWP(8,15),GAL(30),ISYM,VMU,VUJON	130
	1,TEMP,FCR,CAMLER,CAMLET,CAMTER,CAMTET,XJ,YJ,ZJ,RJ,ALP,CREF,TWISTR	JON 140
	COMMON /COST/ LTOTAL,LPAN1,NJW(5),LPANEL,IENTN,LPAN2,EXIT,PTIAL,TWJON	150
	LIST,DF(5),NFP	JON 160
	REWIND 02	JON 170
	LP1=LTOTAL+1	JON 180
	MJ=LPANFL+NCJ(1)	JON 190
	MCON=LAST+NCJ(1)	JON 200
	IPHI=1	JON 210
	JL=LAST+1	JON 220
	IANN=1	JON 230
	LN=1	JON 240
	LN1=1	JON 250
	JMN=1	JON 260
	V*HC=VMJ*ALPC	JON 270

	MK=1	JON 280
	I=LAST+1	JON 290
	II=I-JPANEL	JON 300
	CALL MATRIX (AW,LTOTAL,LPANEL,VMUC,I,MCON,MJ,IPHI,INN,LN,LN1,TEMP,	JON 310
	1LPAN1,ISYM,KCODE,EXIT,LPAN2)	JON 320
	WRITE (01) (AW(K),K=1,LTOTAL)	JON 330
	KI=2	JON 340
	NI=LTOTAL-1	JON 350
	LI=LAST+2	JON 360
	V*P=VMUC	JON 370
10	KJ=LI	JON 380
	IF (LI.GT.LAST) KJ=LI-JPANEL	JON 390
	CALL MATRIX (AW,LTOTAL,LPANEL,VMP,LI,MCON,MJ,IPHI,INN,LN,LN1,TEMP,	JON 400
	1LPAN1,ISYM,KCODE,EXIT,LPAN2)	JON 410
	WRITE (01) (AW(K),K=1,LTOTAL)	JON 420
	IF (KJ.LT.MJ.OR.KJ.EQ.LAST) GO TO 20	JON 430
	IPHI=IPHI+1	JON 440
	MJ=MJ+NCJ(INN)	JON 450
20	CONTINUE	JON 460
	MJI=MJJ(INN)-1	JON 470
	IF (KJ.EQ.MJI) GO TO 30	JON 480
	GO TO 40	JON 490
30	JNM=INN	JON 500
	INN=INN+1	JON 510
40	IF (KJ.EQ.MJJ(JNM)) IPHI=1	JON 520
	IF (LI.EQ.LTOTAL) GO TO 50	JON 530
	GO TO 60	JON 540
50	CONTINUE	JON 550
	IPHI=1	JON 560
	MJ=LPANEL+NCJ(1)	JON 570
	JNM=1	JON 580
	INN=1	JON 590
60	CONTINUE	JON 600
	KI=KI+1	JON 610
	NI=NI-1	JON 620
	IF (LI.EQ.LTOTAL) GO TO 70	JON 630
	IF (LI.EQ.LAST) GO TO 80	JON 640
	LI=LI+1	JON 650
	GO TO 90	JON 660
70	LI=LPANEL+1	JON 670
	GO TO 90	JON 680
80	LI=1	JON 690
90	CONTINUE	JON 700
	JP=LI-LAST+LPANEL	JON 710
	JP1=JP-1	JON 720
	IF (JP.EQ.MJJ(LN1)) LN1=LN1+1	JON 730
	IF (JP1.EQ.MJJ(LN)) LN=LN+1	JON 740
	IF (KI.LE.LTOTAL) GO TO 10	JON 750
	RETURN	JON 760
	END	JON 770-

	SUBROUTINE MATRIX (AW,LTOTAL,LPANEL,VMU,I,MCON,MJ,IPHI,INN,LN,LN1,MTX	10
	ITEMP,LPAN1,ISYM,KCODE,EXIT,LPAN2)	MTX 20
C	TO COMPUTE THE JETON INFLUENCE COEFFICIENT MATRICES	MTX 30
	DIMENSION AW(1)	MTX 40
	DIMENSION W(4)	MTX 50
	DIMENSION SV(300)	MTX 60
	COMMON /GEOM/ HALFSW,XCP(200),YCP(200),ZCP(200),XLE(50),YLE(50),XTMTX	70
	1E(50),PSI(20),CH(95),XV(200),YV(100),SN(8,8),XN(200,2),YN(200,2),ZMTX	80
	2N(200,2),WIDTH(8),YCON(25),SWEEP(50),HALFB,SJ(21,8),EX(95,2),TX(95MTX	90
	3,2),SC(160,5),SI(160,5),LC(3)	MTX 100
	COMMON /SCHEME/ C(2),X(10,41),Y(10,41),SLOPE(15),XL(2,15),XTT(41),MTX	110
	1XLL(41)	MTX 120
	COMMON /AERO/ AM1,AM2,R1,R2,CL(30),CT(30),CD(30),GAM(2,100)	MTX 130
	COMMON /CONST/ NCS,NCW,M1(8),NSJ,NCJ(5),LAST,MJW1(3,5),MJW2(3,5),JMTX	140
	LPANEL,MJJ(5),NW(3),NNJ,NJP	MTX 150
	COMMON /PARAM/ ALPT,ALPC,ALPS,CDF,SDF,TH,TDF	MTX 160
	EQUIVALENC (X(1,1),SV(1))	MTX 170
	PI=3.14159265	MTX 180
	ZJET=YCON(25)	MTX 190
	IUSR=YCON(24)	MTX 200
	OFJ=CDF	MTX 210
	VJT=VMU	MTX 220
	TEM=TEMP	MTX 230
	NN2=NNJ-1	MTX 240
	N1=NNJ-1	MTX 250
	N2=NNJ-2	MTX 260
	N3=NNJ-3	MTX 270
	NJH=(NSJ+1)/2+1	MTX 280
	IF (ISYM.EQ.0) NJH=NSJ/2	MTX 290
	IF (ISYM.EQ.0) NP=NSJ-1	MTX 300
	IF (ISYM.NE.0) NP=NSJ+1	MTX 310
	NJT=NJH-1	MTX 320
	I7=1	MTX 330
	IFF=1	MTX 340
	MM=NW(1)	MTX 350
	MN=NW(1)	MTX 360
	IND=1	MTX 370
	ISN=1	MTX 380
	L1=LPANEL+1	MTX 390
	LAST1=LAST-1	MTX 400
	IF (I.GT.LAST) GO TO 10	MTX 410
	IJ=I	MTX 420
	GO TO 20	MTX 430
10	IJ=I-JPANEL	MTX 440
20	CONTINUE	MTX 450
	DO 240 J=1, LAST	MTX 460
	MI=J-IFF+1	MTX 470
	FN=NN	MTX 480
	IF (J.GT.LPAN1.AND.J.LE.LPAN2) ISN=2	MTX 490

	IF (J.GT.LPAN2.AND.J.LE.LPANEL) ISN=3	MTX 500
	IF (J.GE.LPAN1.AND.J.LT.LPANEL) GO TO 30	MTX 510
	GO TO 40	MTX 520
30	NN=NW(2)	MTX 530
	IF (J.GE.LPAN2.AND.J.LT.LPANEL) NN=NW(3)	MTX 540
40	CONTINUE	MTX 550
	IF (J.GF.LPANEL.AND.J.LT.MJJ(IND)) NN=NCJ(IND)	MTX 560
	CHORD=CH(IZ)	MTX 570
	IF (J.EQ.L1) GO TO 50	MTX 580
	GO TO 60	MTX 590
50	ISN=ISN+1	MTX 600
	L1=MJJ(IND)+1	MTX 610
60	NL=MJJ(IND)-1	MTX 620
	IF (NL.EQ.LAST1) GO TO 70	MTX 630
	IF (J.EQ.NL) IND=IND+1	MTX 640
70	CONTINUE	MTX 650
	X1=XN(J,1)-XCP(IJ)	MTX 660
	X2=XN(J,2)-XCP(IJ)	MTX 670
	X12=XN(J,2)-XN(J,1)	MTX 680
	Y12=YN(J,2)-YN(J,1)	MTX 690
	Z12=ZN(J,2)-ZN(J,1)	MTX 700
	Z1=ZN(J,1)-ZCP(IJ)	MTX 710
	Z2=ZN(J,2)-ZCP(IJ)	MTX 720
	XZJ=X1*Z12-Z1*X12	MTX 730
	DO 220 II=1,2	MTX 740
	IF (II.EQ.1) GO TO 80	MTX 750
	N=1	MTX 760
	GO TO 90	MTX 770
80	N=2	MTX 780
90	CONTINUE	MTX 790
	YC=(-1.)*N*YCP(IJ)	MTX 800
	Y1=YN(J,1)-YC	MTX 810
	Y2=YN(J,2)-YC	MTX 820
	XYK=X1*Y12-Y1*X12	MTX 830
	YZI=Y1*Z12-Z1*Y12	MTX 840
	ALR1=XYK*XYK+XZJ*XZJ+B1*YZI*YZI	MTX 850
	R1B1=SQRT(X1*X1+B1*Y1*Y1+B1*Z1*Z1)	MTX 860
	R2B1=SQRT(X2*X2+B1*Y2*Y2+B1*Z2*Z2)	MTX 870
	U1R1=(X2*X12+B1*Y2*Y12+B1*Z2*Z12)/R2B1-(X1*X12+B1*Y1*Y12+B1*Z1*Z12	MTX 880
	1)/R1R1	MTX 890
	G1B1=(1.-X1/R1R1)/(Y1*Y1+Z1*Z1)	MTX 900
	G2B1=(1.-X2/R2B1)/(Y2*Y2+Z2*Z2)	MTX 910
	IF (I.GT.LPANEL) GO TO 110	MTX 920
	F1=U1R1*XYK/ALR1	MTX 930
	F2=-Y2*G2B1+Y1*G1B1	MTX 940
	IF (J.GT.LPANEL) GO TO 100	MTX 950
	GO TO 200	MTX 960
100	F3=0.	MTX 970
	F4=0.	MTX 980

	F1=2.*F1	MTX 990
	F2=2.*F2	MTX1000
	GO TO 200	MTX1010
110	CONTINUE	MTX1020
	IF (J.LE.LPANEL) GO TO 130	MTX1030
	IF (ABS(B1-R2).LE.0.001) GO TO 120	MTX1040
	ALR2=XYK*XYK+X7J*XZJ+R2*YZI*YZI	MTX1050
	R1R2=SQRT(X1*X1+R2*Y1*Y1+R2*Z1*Z1)	MTX1060
	R2R2=SQRT(X2*X2+R2*Y2*Y2+R2*Z2*Z2)	MTX1070
	UUR2=(X2*X12+R2*Y2*Y12+R2*Z2*Z12)/R2B2-(X1*X12+R2*Y1*Y12+R2*Z1*Z12	MTX1080
	1)/R1B2	MTX1090
	G1R2=(1.-X1/R1R2)/(Y1*Y1+Z1*Z1)	MTX1100
	G2R2=(1.-X2/R2R2)/(Y2*Y2+Z2*Z2)	MTX1110
	GO TO 130	MTX1120
120	ALR2=ALR1	MTX1130
	UUR2=UUR1	MTX1140
	G2R2=G2R1	MTX1150
	G1R2=G1R1	MTX1160
130	CONTINUE	MTX1170
	IF (I.GT.LAST) GO TO 160	MTX1180
	F13=UUR1*XZJ/ALR1	MTX1190
	F12=UUR1*XYK/ALR1	MTX1200
	G13=Z2*G2R1-Z1*G1R1	MTX1210
	G12=-Y2*G2R1+Y1*G1R1	MTX1220
	IF (J.LE.LPANEL) GO TO 140	MTX1230
	F23=UUR2*XZJ/ALR2	MTX1240
	F22=UUR2*XYK/ALR2	MTX1250
	G23=Z2*G2R2-Z1*G1R2	MTX1260
	G22=-Y2*G2R2+Y1*G1R2	MTX1270
	GO TO 150	MTX1280
140	F22=0.	MTX1290
	G22=0.	MTX1300
	F23=0.	MTX1310
	G23=0.	MTX1320
150	F1=-F13*Y(4,IPHI)*(-1.)**N+F12*Y(3,IPHI)	MTX1330
	F2=G13*Y(4,IPHI)*(-1.)**N+G12*Y(3,IPHI)	MTX1340
	F3=-F23*Y(4,IPHI)*(-1.)**N+F22*Y(3,IPHI)	MTX1350
	F4=G23*Y(4,IPHI)*(-1.)**N+G22*Y(3,IPHI)	MTX1360
	IF (J.LE.LPANEL) GO TO 190	MTX1370
	F1=F1*2.	MTX1380
	F2=2.*F2	MTX1390
	F3=2.*F3	MTX1400
	F4=2.*F4	MTX1410
	GO TO 190	MTX1420
160	F1=UUR1*YZI/ALR1	MTX1430
	IF (EXIT.LE.0.001) GO TO 170	MTX1440
	IF (NNJ.EQ.1) GO TO 170	MTX1450
	IF (IJ.GT.LPANEL.AND.IJ.LE.MJJ(1)) VMU=1.	MTX1460
	IF (IJ.GT.LPANEL.AND.IJ.LE.MJJ(1)) TEMP=1.	MTX1470
170	CONTINUE	MTX1480

	F2=0.	MTX1490
	IF (J.LE.LPANEL) GO TO 180	MTX1500
	F3=UUB2*YZI/ALR2	MTX1510
	F4=0.	MTX1520
	F1=-F1*VMU*VMU*2.*TEMP	MTX1530
	F3=-F3*2.	MTX1540
	GO TO 190	MTX1550
180	F1=-F1*VMU*VMU*TEMP	MTX1560
190	CONTINUE	MTX1570
200	W(II)=(F1+F2)*CHORD*SN(MI,ISN)/(8.*FN)	MTX1580
	IF (J.LE.LPANEL) GO TO 210	MTX1590
	IF (II.EQ.2) GO TO 210	MTX1600
	K2=II+2	MTX1610
	W(K2)=(F3+F4)*CHORD*SN(MI,ISN)/(8.*FN)	MTX1620
210	CONTINUE	MTX1630
220	CONTINUE	MTX1640
	IF (J.LT.MM) GO TO 230	MTX1650
	IZ=IZ+1	MTX1660
	IFF=MM+1	MTX1670
	MM=MM+NN	MTX1680
230	CONTINUE	MTX1690
	IF (J.LE.LPANEL) JA=J+2*JPANEL	MTX1700
	IF (J.GT.LPANEL) JA=J-LPANEL+JPANEL	MTX1710
	A*(JA)=W(1)+W(2)	MTX1720
	SV(JA)=W(1)	MTX1730
	IF (J.LE.LPANEL) GO TO 240	MTX1740
	J1=J-LPANEL	MTX1750
	A*(J1)=W(3)	MTX1760
	VMU=VUT	MTX1770
	TEMP=TFM	MTX1780
240	CONTINUE	MTX1790
	IF (KCODE.EQ.0) GO TO 360	MTX1800
	IF (IUSB.EQ.1.AND.7JET.GT.0.01) GO TO 340	MTX1810
	IF (DFJ.LE.0.0001) GO TO 340	MTX1820
	IF (NNJ.EQ.1.AND.I.LE.LPANEL) GO TO 340	MTX1830
	IF (NNJ.EQ.1.AND.I.GT.LPANEL) GO TO 250	MTX1840
	IF (I.LE.MJJ(N1).OR.I.GT.LAST) GO TO 340	MTX1850
250	CONTINUE	MTX1860
	IF (I.GT.LAST) GO TO 340	MTX1870
	IF (IPHI.EQ.NJH) GO TO 340	MTX1880
	IF (ISYM.NE.0.AND.IPHI.EQ.1) GO TO 340	MTX1890
	IF (IPHI.LT.NJH) IL=IPHI-ISYM	MTX1900
	IF (IPHI.GT.NJH) IL=IPHI-NJH	MTX1910
	REWIND 2	MTX1920
	MF=IJ-MJJ(N1)-(IPHI-1)*NCJ(NNJ)	MTX1930
	FNNJ=NNJ	MTX1940
	DISTJ=SDF	MTX1950
	DLX=DISTJ*0.5*PI/FNNJ	MTX1960
	SZX=-(1.-VMU)	MTX1970
	IQ=(IL-1)*NCJ(NNJ)	MTX1980

	CALL SKIP (IQ,JPANEL)	MTX1990
	DO 290 JJ=1,MF	MTX2000
	READ (02) (SV(K),K=1,JPANFL)	MTX2010
	IF (JJ.EQ.MF) GO TO 260	MTX2020
	DXTH=DLX*PSI(JJ)/TH	MTX2030
	GO TO 270	MTX2040
260	DXTH=DLX*PSI(JJ)*0.5/TH	MTX2050
270	CONTINUE	MTX2060
	PROD=SZX*DXTH	MTX2070
	DO 280 K1=1,JPANEL	MTX2080
	KK=K1+JPANEL	MTX2090
280	AW(KK)=AW(KK)+PROD*SV(K1)	MTX2100
290	CONTINUE	MTX2110
	ID=NCJ(NNJ)-MF+((NP-1-ISYM)/2-1)*NCJ(NNJ)	MTX2120
	CALL SKIP (IQ,JPANEL)	MTX2130
	DO 330 JJ=1,MF	MTX2140
	READ (02) (SV(K),K=1,JPANEL)	MTX2150
	IF (JJ.EQ.MF) GO TO 300	MTX2160
	DXTH=DLX*PSI(JJ)/TH	MTX2170
	GO TO 310	MTX2180
300	DXTH=DLX*PSI(JJ)*0.5/TH	MTX2190
310	PROD=SZX*DXTH	MTX2200
	DO 320 K1=1,JPANFL	MTX2210
	KK=K1+JPANEL	MTX2220
320	AW(KK)=AW(KK)-PROD*SV(K1)	MTX2230
330	CONTINUE	MTX2240
340	CONTINUE	MTX2250
	IF (EXIT.LE.0.001) GO TO 350	MTX2260
	IF (NNJ.EQ.1) GO TO 350	MTX2270
	IF (IJ.GT.LPANEL.AND.IJ.LE.MJJ(1)) VMU=1.	MTX2280
	IF (IJ.GT.LPANEL.AND.IJ.LE.MJJ(1)) TEMP=1.	MTX2290
350	CONTINUE	MTX2300
360	IF (I.LE.LAST) GO TO 710	MTX2310
	IF (IPHI.EQ.NJH) GO TO 570	MTX2320
	IF (ISYM.NE.0.AND.IPHI.EQ.1) GO TO 570	MTX2330
	IF (NNJ.EQ.1) GO TO 430	MTX2340
	IF (IJ.GT.MJJ(N1)) GO TO 430	MTX2350
	IF (IPHI.GT.NJH.AND.ZJET.LE.0.01) GO TO 430	MTX2360
	IF (IPHI.GT.NJH) L1=NJH	MTX2370
	IF (ISYM.EQ.0.AND.IPHI.GT.NJH) L1=NJH+1	MTX2380
	IF (IPHI.LE.NJH) L1=1	MTX2390
	NZ=1	MTX2400
	IF (NW(2).NE.0.AND.NW(3).EQ.0) NZ=2	MTX2410
	IF (NW(3).NE.0) NZ=3	MTX2420
	IF (NNJ.LE.3.AND.NW(2).NE.0) IR=N2	MTX2430
	IF (NNJ.LE.3.AND.NW(2).EQ.0) IR=N1	MTX2440
	IF (NNJ.GE.4.AND.NW(3).NE.0) IR=N3	MTX2450
	IF (NNJ.EQ.4.AND.NW(3).EQ.0) IR=N2	MTX2460
	DO 420 NR=1,NZ	MTX2470
	K1=MJW1(NR,NJP)+(IPHI-L1-ISYM)*NW(NR)-1	MTX2480

	K2=LC(NR)+IPHI-L1-ISYM	MTX2490
	KNW=NW(NR)	MTX2500
	K1=K1-KNW	MTX2510
	K2=K2-1	MTX2520
	NR=3	MTX2530
	IF (K1.GE.0) GO TO 370	MTX2540
	K1=K1+KNW	MTX2550
	K2=K2+1	MTX2560
	NR=2	MTX2570
370	DO 410 NQ=1,MP	MTX2580
	SUM=0.	MTX2590
	DO 380 KK=1,KNW	MTX2600
	KL=K1+KK	MTX2610
	JA=KL+2*JPANEL	MTX2620
380	SUM=SUM+SV(JA)	MTX2630
	CALL INTEG (RES,KNW,K1,K2,IJ,B1,IR)	MTX2640
	DO 400 KK=1,KNW	MTX2650
	KL=K1+KK	MTX2660
	JA=KL+2*JPANEL	MTX2670
	AA=1.	MTX2680
	DO 390 L=1,KNW	MTX2690
	LL=K1+L	MTX2700
	IF (L.EQ.KK) GO TO 390	MTX2710
	AA=AA*(XCP(IJ)-XV(LL))/(XV(KL)-XV(LL))	MTX2720
390	CONTINUE	MTX2730
	AW(JA)=AW(JA)-SUM*AA-RES*AA*VMU*VMU*TEMP	MTX2740
400	CONTINUE	MTX2750
	K1=K1+KNW	MTX2760
	K2=K2+1	MTX2770
410	CONTINUE	MTX2780
	IR=IR+1	MTX2790
420	CONTINUE	MTX2800
430	CONTINUE	MTX2810
	IF (KCODE.FG.0) GO TO 570	MTX2820
	IF (NW(2).EQ.0) NSTRIP=NCS	MTX2830
	IF (NW(2).NE.0.AND.NW(3).EQ.0) NSTRIP=NCS*2	MTX2840
	IF (NW(3).NE.0) NSTRIP=NCS*3	MTX2850
	IF (IPHI.LT.NJH) IP=NJH+1	MTX2860
	IF (IPHI.GT.NJH) IP=ISYM+1	MTX2870
	IF (NNJ.EQ.1) GO TO 480	MTX2880
	IF (IJ.GT.MJJ(N1)) GO TO 480	MTX2890
	IF (NNJ.EQ.2) GO TO 490	MTX2900
	IF (IJ.GT.MJJ(N2)) GO TO 490	MTX2910
	IF (NNJ.EQ.3) GO TO 470	MTX2920
	IF (IJ.GT.MJJ(N3)) GO TO 460	MTX2930
	IF (NNJ.EQ.4) GO TO 450	MTX2940
	IF (NNJ.EQ.5.AND.IJ.GT.MJJ(NNJ-4)) GO TO 440	MTX2950
	LI=NNJ-4	MTX2960
	I7=NSTRIP	MTX2970
	GO TO 500	MTX2980

440	L1=N3 I7=NSTRIP+NP GO TO 500	MTX2990 MTX3000 MTX3010
450	L1=N3 I7=NSTRIP GO TO 500	MTX3020 MTX3030 MTX3040
460	L1=N2 I7=NSTRIP+(NNJ-3)*NP GO TO 500	MTX3050 MTX3060 MTX3070
470	CONTINUE L1=N2 I7=NSTRIP GO TO 500	MTX3080 MTX3090 MTX3100 MTX3110
480	L1=NNJ I7=NSTRIP+(NNJ-1)*NP GO TO 500	MTX3120 MTX3130 MTX3140
490	L1=N1 I7=NSTRIP+(NNJ-2)*NP	MTX3150 MTX3160
500	CONTINUE I7=I7+IP NT=NJT IF (ISYM.NE.0) NT=NJT-1 KNW=NCJ(L1) DO 560 KP=1,NT SUM1=0. SUM2=0. K1=MJJ(L1)-NP*NCJ(L1)+(KP-1)*NCJ(L1)+(IP-1)*NCJ(L1) DO 510 KK=1,KNW KL=K1+KK KJ=KL+JPANFL IA=KL-LPANFL+JPANFL IB=KJ-LAST SUM1=SUM1+SV(IA) SUM2=SUM2+AW(IB)	MTX3170 MTX3180 MTX3190 MTX3200 MTX3210 MTX3220 MTX3230 MTX3240 MTX3250 MTX3260 MTX3270 MTX3280 MTX3290 MTX3300 MTX3310 MTX3320
510	CALL INTEG (RES,KNW,K1,I7,IJ,B1,L1) IF (ABS(B1-B2).LF.0.001) GO TO 520 CALL INTEG (PEF,KNW,K1,I7,IJ,B2,L1) GO TO 530	MTX3330 MTX3340 MTX3350 MTX3360
520	REF=RES	MTX3370
530	DO 550 KK=1,KNW KL=K1+KK KJ=KL+JPANEL IA=KL-LPANEL+JPANEL IB=KJ-LAST AA=1. DO 540 L=1,KNW LL=K1+L IF (L.EQ.KK) GO TO 540 AA=AA*(XCP(IJ)-XV(LL))/(XV(KL)-XV(LL))	MTX3380 MTX3390 MTX3400 MTX3410 MTX3420 MTX3430 MTX3440 MTX3450 MTX3460 MTX3470

540	CONTINUE	MTX3480
	AW(IA)=AW(IA)-SUM1*AA-RES*AA*VMU*VMU*TEMP*2.	MTX3490
	AW(IB)=AW(IR)-SUM2*AA-REF*AA*2.	MTX3500
550	CONTINUE	MTX3510
	IZ=IZ+1	MTX3520
560	CONTINUE	MTX3530
570	CONTINUE	MTX3540
	SK=1.	MTX3550
	IF (IPHI.GT.NJH) SK=-1.	MTX3560
	JT=I-LAST+LPANEL	MTX3570
	K=MCON-LAST-NCJ(LN)+LPANEL	MTX3580
	JNJ=NCJ(LN)	MTX3590
	GO 590 KK=1,JNJ	MTX3600
	KL=K+KK	MTX3610
	KJ=KL+JPANEL	MTX3620
	TA=KL-LPANEL+JPANEL	MTX3630
	TR=KJ-LAST	MTX3640
	AA=1.	MTX3650
	GO 580 L=1,JNJ	MTX3660
	LL=K+L	MTX3670
	IF (L.EQ.KK) GO TO 580	MTX3680
	AA=AA*(XCP(JI)-XV(LL))/(XV(KL)-XV(LL))	MTX3690
580	CONTINUE	MTX3700
	AW(IB)=AW(IR)+AA*SK	MTX3710
590	AW(IA)=AW(IA)-AA*VMU*VMU*TEMP*SK	MTX3720
	IF (I.EQ.MCON.AND.I.LT.LTOTAL) MCON=MCON+NCJ(LN1)	MTX3730
	IF (KCODE.EQ.0) GO TO 680	MTX3740
	IF (IUSB.EQ.1.AND.ZJET.GT.0.01) GO TO 680	MTX3750
	IF (NNJ.EQ.1) GO TO 680	MTX3760
	IF (IJ.GT.MJJ(N1)) GO TO 680	MTX3770
	IF (IPHI.LE.NJH) GO TO 680	MTX3780
	L1=NJH	MTX3790
	IF (ISYM.EQ.0) L1=NJH+1	MTX3800
	IF (NW(2).EQ.0) GO TO 610	MTX3810
	IF (NW(3).EQ.0) GO TO 600	MTX3820
	IF (IJ.GT.MJJ(N2)) GO TO 640	MTX3830
	IF (IJ.GT.MJJ(N3)) GO TO 630	MTX3840
	IF (NNJ.EQ.4) GO TO 620	MTX3850
	IF (NNJ.EQ.5.AND.IJ.GT.MJJ(NNJ-4)) GO TO 620	MTX3860
	GO TO 680	MTX3870
600	IF (IJ.GT.MJJ(N2)) GO TO 630	MTX3880
	IF (NNJ.EQ.3) GO TO 620	MTX3890
	IF (NNJ.EQ.4.AND.IJ.GT.MJJ(N3)) GO TO 620	MTX3900
	GO TO 680	MTX3910
610	IF (NNJ.EQ.2) GO TO 620	MTX3920
	IF (NNJ.EQ.3.AND.IJ.GT.MJJ(N2)) GO TO 620	MTX3930
	GO TO 680	MTX3940
620	K1=MJW1(1,NJP)+(IPHI-L1-ISYM)*NW(1)-1	MTX3950
	KNW=NW(1)	MTX3960
	GO TO 650	MTX3970

630	K1=MJW1(2,NJP)+(IPHI-L1-ISYM)*NW(2)-1	MTX3980
	KNW=NW(2)	MTX3990
	GO TO 650	MTX4000
640	K1=MJW1(3,NJP)+(IPHI-L1-ISYM)*NW(3)-1	MTX4010
	KNW=NW(3)	MTX4020
650	DO 670 KK=1,KNW	MTX4030
	KL=K1+KK	MTX4040
	JA=KL+2*JPANEL	MTX4050
	AA=1.	MTX4060
	DO 660 L=1,KNW	MTX4070
	LL=K1+L	MTX4080
	IF (L.EQ.KK) GO TO 660	MTX4090
	AA=AA*(XCP(IJ)-XV(LL))/(XV(KL)-XV(LL))	MTX4100
660	CONTINUE	MTX4110
670	AW(JA)=AW(JA)-AA*VMU*VMU*TEMP*0.5	MTX4120
680	CONTINUE	MTX4130
	IF (KCODE.EQ.0) GO TO 710	MTX4140
	IF (ZJET.GT.0.01) GO TO 710	MTX4150
	IF (DFJ.LE.0.0001) GO TO 710	MTX4160
	IF (NNJ.EQ.1) GO TO 690	MTX4170
	IF (IJ.LE.MJJ(N1)) GO TO 710	MTX4180
690	CONTINUE	MTX4190
	IF (IPHI.EQ.NJH) GO TO 710	MTX4200
	IF (ISYM.NE.0.AND.IPHI.EQ.1) GO TO 710	MTX4210
	DO 700 J=1,JPANEL	MTX4220
	JJ=J+JPANEL	MTX4230
700	SV(J)=-AW(JJ)	MTX4240
	WRITE (02) (SV(J),J=1,JPANEL)	MTX4250
710	CONTINUE	MTX4260
	VMU=VUT	MTX4270
	TEMP=TEM	MTX4280
	RETURN	MTX4290
C	END	MTX4300
	SUBROUTINE SKIP (I,JPANEL)	MTX4310-
	DIMENSION DUMMY(200)	SKP 10
	IF (I.EQ.0) GO TO 20	SKP 20
	DO 10 J=1,I	SKP 30
	READ (02) (DUMMY(K),K=1,JPANEL)	SKP 40
10	CONTINUE	SKP 50
20	RETURN	SKP 60
	END	SKP 70
	OVERLAY(USBOWB,4,0)	SKP 80-
	PROGRAM SOLUTN	SOL 10
C	TO SOLVE THE JET ON AND JET OFF EQUATIONS	SOL 20
C		SOL 30
C	GAMMA MUST BE DIMENSIONED TO HAVE AT LEAST (N+1)**2/4 ELEMENTS,	SOL 40
C	WHERE N IS THE SIZE OF THE MATRIX ***	SOL 50
C		SOL 60
	DIMENSION AW(300), CA(300), GAMMA(20170)	SOL 70

	DIMENSION GAMVR(300)	SOL 80
	COMMON /CODE/ KCODE	SOL 90
	COMMON /SCHEME/ C(2),X(10,41),Y(10,41),SLOPE(15),XL(2,15),XTT(41),SOL	100
	IXLL(41)	SOL 110
	COMMON /GEOM/ HALFSW,XCP(200),YCP(200),ZCP(200),XLE(50),YLE(50),XTSOL	120
	IE(50),PSI(20),CH(95),XV(200),YV(100),SN(8,8),XN(200,2),YN(200,2),ZSOL	130
	2N(200,2),WIDTH(8),YCON(25),SWEEP(50),HALFB,SJ(21,8),EX(95,2),TX(95SOL	140
	3,2),SC(160,5),SI(160,5),LC(3)	SOL 150
	COMMON /PARAM/ ALPT,ALPC,ALPS,CDF,SDF,TH,TDF	SOL 160
	COMMON /AERO/ AM1,AM2,B1,B2,CL(30),CT(30),CD(30),GAM(2,100)	SOL 170
	COMMON /ADD/ CP(100),CM(30),BREAK(8),SWP(8,15),GAL(30),ISYM,VMU,VUSOL	180
	1,TEMP,FCR,CAMLER,CAMLET,CAMTER,CAMTET,XJ,YJ,ZJ,RJ,ALP,CREF,TWISTR	SOL 190
	COMMON /CONST/ NCS,NCW,M1(8),NSJ,NCJ(5),LAST,MJW1(3,5),MJW2(3,5),JSOL	200
	IPANEL,MJJ(5),NW(3),NNJ,NJP	SOL 210
	COMMON /COST/ LTOTAL,LPANI,NJW(5),LPANEL,IENTN,LPAN2,EXIT,PTIAL,TWSOL	220
	1IST,DF(5),NFP	SOL 230
	REWIND 01	SOL 240
	IUSB=YCON(24)	SOL 250
	IC=IENTN	SOL 260
	Z7=YCON(25)	SOL 270
	ITN=YCON(23)	SOL 280
	IC=1	SOL 290
	J1=LPANEL+1	SOL 300
	LP1=LTOTAL+1	SOL 310
	HR=B1	SOL 320
	DFJ=CDF	SOL 330
	NA=3	SOL 340
	IF (NW(2).EQ.0) NA=1	SOL 350
	IF (NW(2).NE.0.AND.NW(3).EQ.0) NA=2	SOL 360
10	CONTINUE	SOL 370
	IG=1	SOL 380
	MG=NW(1)	SOL 390
	NG=NW(1)	SOL 400
	READ (01) (AW(I),I=1,J1)	SOL 410
	XH=XCP(1)	SOL 420
	YR=YCP(1)	SOL 430
	PHPV=0.	SOL 440
	IF (IUSB.EQ.1.AND.ITN.EQ.0) GO TO 20	SOL 450
	CALL INDVEL (XB,YR,XJ,YJ,ZJ,RJ,BB,PHRV,PHX,TEMP,VU,PHY,ISYM)	SOL 460
20	CONTINUE	SOL 470
	AW(J1)=AW(J1)+XTT(IG)+PHPV/(ALPC*VU)	SOL 480
	DO 30 I=1,LPANEL	SOL 490
30	GAMMA(I)=-AW(I+1)/AW(I)	SOL 500
	NJ=LPANEL-1	SOL 510
	DO 60 IJ=2,LPANEL	SOL 520
	READ (01) (AW(K),K=1,J1)	SOL 530
	XB=XCP(IJ)	SOL 540
	YB=YCP(IJ)	SOL 550
	IF (IUSB.EQ.1.AND.ITN.EQ.0) GO TO 40	SOL 560

	CALL INDVEL (XB,YB,XJ,YJ,ZJ,RJ,BB,PHRV,PHX,TEMP,VU,PHY,ISYM)	SOL 570
40	CONTINUE	SOL 580
	AW(J1)=AW(J1)+XTT(IG)*PHRV/(ALPC*VU)	SOL 590
	IK=IJ	SOL 600
	CALL VMSEQN (NJ,IK,AW,GAMMA,CA)	SOL 610
	NJ=NJ-1	SOL 620
	IF (IJ.GE.LPAN1.AND.IJ.LT.LPAN2) NG=NW(2)	SOL 630
	IF (IJ.GE.LPAN2.AND.IJ.LT.LPANEL) NG=NW(3)	SOL 640
	IF (IJ.LT.MG) GO TO 50	SOL 650
	IG=IG+1	SOL 660
	MG=MG+NG	SOL 670
50	IF (IJ.EQ.LPAN1.OR.IJ.EQ.LPAN2) IG=1	SOL 680
60	CONTINUE	SOL 690
	DO 70 I=1,LPANEL	SOL 700
70	GAM(IC,I)=GAMMA(I)	SOL 710
	IF (ABS(B1-B2).LE.0.001) GO TO 80	SOL 720
	IC=IC+1	SOL 730
	B1=B2	SOL 740
	IF (IC.GT.2) GO TO 80	SOL 750
	GO TO 10	SOL 760
80	CONTINUE	SOL 770
	VMUC=VMU*ALPC	SOL 780
	IPHI=1	SOL 790
	MJ=LPANEL+NCJ(1)	SOL 800
	INN=1	SOL 810
	JNN=1	SOL 820
	I=LAST+1	SOL 830
	READ (01) (AW(K),K=1,LTOTAL)	SOL 840
	CALL STREAM (ALPHA,VMUC,I,IPHI,LPANEL,TEMP,LPAN1,LPAN2,ISYM,KCODE,	SOL 850
	1,EXIT,MJ)	SOL 860
	AW(LP1)=ALPHA	SOL 870
	DO 90 I=1,LTOTAL	SOL 880
90	GAMMA(I)=-AW(I+1)/AW(1)	SOL 890
	KI=2	SOL 900
	NI=LTOTAL-1	SOL 910
	LI=LAST+2	SOL 920
	IH=NW(NA)+MJW1(NA,NJP)-1	SOL 930
100	KJ=LI	SOL 940
	IF (LI.GT.LAST) KJ=LI-JPANEL	SOL 950
	READ (01) (AW(K),K=1,LTOTAL)	SOL 960
	CALL STREAM (ALPHA,VMUC,LI,IPHI,LPANEL,TEMP,LPAN1,LPAN2,ISYM,KCODE	SOL 970
	1,EXIT,MJ)	SOL 980
	IF (KCODE.EQ.0) GO TO 120	SOL 990
	IF (ZZ.GE.0.01) GO TO 120	SOL1000
C	ADDITIONAL EXTERNAL FLOW DEFLECTION IS ALLOWED IF THE JET ANGLE IS	SOL1010
C	GREATER THAN THE FLAP ANGLE BECAUSE OF THE EFFECT OF FINITE TRAI-	SOL1020
C	LING-EDGE ANGLES. FOR THIN AIRFOILS, THIS CAN BE ELIMINATED BY	SOL1030
C	INSERTING THE STATEMENT, IF (KCODE.EQ.1) GO TO 63	SOL1040
	IF (LI.GE.MJW1(NA,NJP).AND.LI.LE.MJW2(NA,NJP)) GO TO 110	SOL1050

	GO TO 120	SOL1060
110	IF (LI.NE.IH) GO TO 120	SOL1070
	IF ((DFJ-TDF).LT.0.) GO TO 120	SOL1080
	CZT=CAMTER-(CAMTER-CAMTET)*YCP(LI)/HALFB	SOL1090
	APA=0.5*(DFJ-TDF+CZT)	SOL1100
	IF (VMU.GT.0.85) APA=APA*(1.-VMU)/0.15	SOL1110
	IF (APA.LT.0.) APA=0.	SOL1120
	ALPHA=ALPHA+APA	SOL1130
	IH=IH+NW(NA)	SOL1140
120	CONTINUE	SOL1150
	AW(LP1)=ALPHA	SOL1160
	CALL VMSEQN (NI,KI,AW,GAMMA,CA)	SOL1170
	IF (KJ.LT.MJ.OR.KJ.EQ.LAST) GO TO 130	SOL1180
	IPHI=IPHI+1	SOL1190
	MJ=MJ+NCJ(INN)	SOL1200
130	CONTINUE	SOL1210
	MJI=MJJ(INN)-1	SOL1220
	IF (KJ.EQ.MJI) GO TO 140	SOL1230
	GO TO 150	SOL1240
140	JNN=INN	SOL1250
	INN=INN+1	SOL1260
150	IF (KJ.EQ.MJJ(JNN)) IPHI=1	SOL1270
	IF (LI.EQ.LTOTAL) GO TO 160	SOL1280
	GO TO 170	SOL1290
160	CONTINUE	SOL1300
	IPHI=1	SOL1310
	MJ=L PANEL+NCJ(1)	SOL1320
	JNN=1	SOL1330
	INN=1	SOL1340
170	CONTINUE	SOL1350
	KI=KI+1	SOL1360
	NI=NI-1	SOL1370
	IF (LI.EQ.LTOTAL) GO TO 180	SOL1380
	IF (LI.EQ.LAST) GO TO 190	SOL1390
	LI=LI+1	SOL1400
	GO TO 200	SOL1410
180	LI=L PANEL+1	SOL1420
	GO TO 200	SOL1430
190	LI=1	SOL1440
200	CONTINUE	SOL1450
	IF (KI.LE.LTOTAL) GO TO 100	SOL1460
	IA=2*JPANEL	SOL1470
	JPAN1=JPANEL+1	SOL1480
	DO 210 I=1,LTOTAL	SOL1490
210	GAMVR(I)=GAMMA(I)	SOL1500
	IF (IUSB.EQ.1.AND.ITN.EQ.0) GO TO 260	SOL1510
	IG=1	SOL1520
	MG=NW(1)	SOL1530
	NG=NW(1)	SOL1540

	REWIND 01	SOL1550
	READ (01) (AW(I),I=1,J1)	SOL1560
	AW(J1)=AW(J1)+XTT(IG)	SOL1570
	DO 220 I=1,LPANEL	SOL1580
220	GAMMA(I)=-AW(I+1)/AW(1)	SOL1590
	NJ=LPANEL-1	SOL1600
	DO 240 IJ=2,LPANEL	SOL1610
	READ (01) (AW(K),K=1,J1)	SOL1620
	AW(J1)=AW(J1)+XTT(IG)	SOL1630
	IK=IJ	SOL1640
	CALL VMSEQN (NJ,IK,AW,GAMMA,CA)	SOL1650
	NJ=NJ-1	SOL1660
	IF (IJ.GE.LPAN1.AND.IJ.LT.LPAN2) NG=NW(2)	SOL1670
	IF (IJ.GE.LPAN2.AND.IJ.LT.LPANEL) NG=NW(3)	SOL1680
	IF (IJ.LT.MG) GO TO 230	SOL1690
	IG=IG+1	SOL1700
	MG=MG+NG	SOL1710
230	IF (IJ.EQ.LPAN1.OR.IJ.EQ.LPAN2) IG=1	SOL1720
240	CONTINUE	SOL1730
	DO 250 I=1,LPANEL	SOL1740
250	GAM(2,I)=GAMMA(I)	SOL1750
	GO TO 280	SOL1760
260	DO 270 I=1,LPANEL	SOL1770
270	GAM(2,I)=GAM(1,I)	SOL1780
280	CONTINUE	SOL1790
	CAM=CAMLER	SOL1800
	CAMT=CAMLET	SOL1810
	CALL THRUST (LTOTAL,LPANEL,GAMVR,CAM,LPAN1,VU,XJ,YJ,ZJ,RJ,TEMP,GALS	SOL1820
	1,ISYM,LPAN2,CAMT)	SOL1830
	DO 290 I=1,LPANEL	SOL1840
	IR=I+IA	SOL1850
	IC=1	SOL1860
290	GAMVR(I)=GAMVP(IR)+GAM(IC,I)	SOL1870
	DO 300 I=1,LPANEL	SOL1880
300	CP(I)=GAMVR(I)*2.*ALPC	SOL1890
	RETURN	SOL1900
C		SOL1910
	END	SOL1920-
	SUBROUTINE INDVEL (XD,Y,XJ,YJ,ZJ,RJ,B2,PHRV,PHX,T,U,PHY,ISYM)	IND 10
C	TO COMPUTE THE INDUCED VELOCITIES DUE TO JET ENTRAINMENT	IND 20
	DIMENSION VZ(2), VX(2), VY(2)	IND 30
	COMMON /JET/ PK1,XC,X(31),A(31),B(31)	IND 40
	REJ=T	IND 50
	VZ(2)=0.	IND 60
	VX(2)=0.	IND 70
	VY(2)=0.	IND 80
	SRJ=SQRT(REJ)	IND 90
	XR=(XD-XJ)/RJ	IND 100
	NCOT=ISYM+1	IND 110

	DO 40 K=1,NCOT	IND 120
	IF (K.EQ.1) FC=1.	IND 130
	IF (K.EQ.2) FC=-1.	IND 140
	RR=SQRT(ZJ*ZJ+(Y*FC-YJ)**2)/RJ	IND 150
	F1=SQRT((XB-XC)**2+B2*RB*RB)	IND 160
	F2=SQRT(XB**2+B2*RB*RB)	IND 170
	G10=(XB-XC)/F1-XB/F2	IND 180
	G20=1./F1-1./F2	IND 190
	SUMR=-(A(1)+B(1)*XB)*G10/RB-B2*RB*B(1)*G20	IND 200
	SUMX=(A(1)+B(1)*XB)*G20-P(1)*G10+B(1)*ALOG((XB-XC+F1)/(XB+F2))	IND 210
	IF (U.LE.0.01) GO TO 20	IND 220
	J=2	IND 230
10	SUM1=SUMR	IND 240
	SUM2=SUMX	IND 250
	F1=SQRT((XB-X(J))**2+B2*RB*RB)	IND 260
	F2=SQRT((XB-X(J-1))**2+B2*RB*RB)	IND 270
	G1=(XB-X(J))/F1-(XB-X(J-1))/F2	IND 280
	G2=1./F1-1./F2	IND 290
	SUMR=SUMR-(A(J)+B(J)*XB)*G1/RB-B2*RB*B(J)*G2	IND 300
	SUMX=SUMX+(A(J)+B(J)*XB)*G2-B(J)*G1+B(J)*ALOG((XB-X(J)+F1)/(XB-X(J-1)+F2))	IND 310
	IF (J.GE.31) GO TO 30	IND 320
	J=J+1	IND 330
	GO TO 10	IND 340
20	SUMR=SUMR+0.32*(1.+(XB-XC)/F1)/RB	IND 350
	SUMX=SUMX-0.32/F1	IND 370
30	PHRV=SRJ*0.25*SUMR*ZJ/(RB*RJ)	IND 380
	PHY=-SRJ*0.25*SUMP*(Y-YJ*FC)/(RB*RJ)	IND 390
	PHX=-SRJ*0.25*SUMX	IND 400
	VX(K)=PHX/2.	IND 410
	VY(K)=PHY/2.	IND 420
40	VZ(K)=PHRV/2.	IND 430
	PHRV=VZ(1)+VZ(2)	IND 440
	PHX=VX(1)+VX(2)	IND 450
	PHY=VY(1)+VY(2)	IND 460
	RETURN	IND 470
C	END	IND 480
	SUBROUTINE STREAM (ALPHA,VMU,I,IPHI,L PANEL,TEMP,L PAN1,L PAN2,ISYM,KSTM	IND 490-
	1CODE,EXIT,MJ)	STM 10
C	TO COMPUTE THE RIGHT HAND SIDE OF THE SIMULTANEOUS EQUATIONS	STM 20
	DIMENSION PHIN(300)	STM 30
	COMMON /SCHEME/ C(2),X(10,41),Y(10,41),SLOPE(15),XL(2,15),XTT(41),	STM 40
	1XLL(41)	STM 50
	COMMON /GEOM/ HALFSW,XCP(200),YCP(200),ZCP(200),XLE(50),YLE(50),XTSTM	STM 60
	1F(50),PSI(20),CH(95),XV(200),YV(100),SN(8,8),XN(200,2),YN(200,2),ZSTM	STM 70
	2N(200,2),WIDTH(8),YCON(25),SWEEP(50),HALFB,SJ(21,8),EX(95,2),TX(95STM	STM 80
	3,2),SC(160,5),SI(160,5),LC(3)	STM 90
	COMMON /AERO/ AM1,AM2,B1,R2,CL(30),CT(30),CD(30),GAM(2,100)	STM 100
		STM 110

	COMMON /CONST/ NCS,NCW,M1(8),NSJ,NCJ(5),LAST,MJW1(3,5),MJW2(3,5),JSTM	120
	1 PANEL,MJJ(5),NW(3),NNJ,NJP	STM 130
	COMMON /PARAM/ ALPT,ALPC,ALPS,CDF,SDF,TH,TDF	STM 140
	EQUIVALENCE (X(1,1),PHIN(1))	STM 150
	PI=3.14159265	STM 160
	IUSB=YCON(24)	STM 170
	ZJET=YCON(25)	STM 180
	N1=NNJ-1	STM 190
	N2=NNJ-2	STM 200
	N3=NNJ-3	STM 210
	NJH=(NSJ+1)/2+1	STM 220
	IF (ISYM.EQ.0) NJH=NSJ/2	STM 230
	NP=NJH-1	STM 240
	IF (ISYM.EQ.0) NP=NJH	STM 250
	ALPHA=0.	STM 260
	IF (I.GT.LPANEL) GO TO 10	STM 270
	GO TO 220	STM 280
10	IF (I.GT.LAST) GO TO 100	STM 290
	IF (EXIT.LE.0.001) GO TO 20	STM 300
	IF (NNJ.EQ.1) GO TO 20	STM 310
	IF (I.LE.MJJ(1).AND.I.NE.MJ) GO TO 220	STM 320
20	CONTINUE	STM 330
	ALPHA=ALPT*Y(3,IPHI)*(1.-VMU)	STM 340
	IF (TH.LE.0.001) GO TO 30	STM 350
	IF (IPHI.EQ.NJH) GO TO 30	STM 360
	IF (ISYM.NE.0.AND.IPHI.EQ.1) GO TO 30	STM 370
	IF (I.GT.MJJ(N1)) ALPHA=ALPHA+CDF*(1.-VMU)	STM 380
30	CONTINUE	STM 390
	IF (ABS(B1-B2).LE.0.001) GO TO 40	STM 400
	CALL NORSPD (I,ALPH,LPANEL,IPHI,LPAN1,LPAN2)	STM 410
	ALPHA=ALPHA+ALPH	STM 420
40	IF (KCODE.EQ.0) GO TO 220	STM 430
	IF (EXIT.LE.0.001) GO TO 50	STM 440
	IF (I.LE.MJJ(1).AND.I.EQ.MJ) ALPHA=ALPHA/2.	STM 450
50	IF (IPHI.EQ.NJH) GO TO 220	STM 460
	IF (ISYM.NE.0.AND.IPHI.EQ.1) GO TO 220	STM 470
	IF (IUSB.EQ.1.AND.ZJET.GT.0.01) GO TO 220	STM 480
	IF (CDF.LT.0.0001) GO TO 220	STM 490
	IF (NNJ.EQ.1) GO TO 60	STM 500
	IF (I.LE.MJJ(N1)) GO TO 220	STM 510
60	IF (IPHI.LT.NJH) IL=IPHI+ISYM	STM 520
	IF (IPHI.GT.NJH) IL=IPHI-NJH+ISYM	STM 530
	MF=I-MJJ(N1)-(IPHI-1)*NCJ(NNJ)	STM 540
	FNNJ=NNJ	STM 550
	DISTJ=SDF	STM 560
	DLX=DISTJ*0.5*PI/FNNJ	STM 570
	SZX=-(1.-VMU)	STM 580
	IQ=(IL-1)*NCJ(NNJ)	STM 590

	IF (NNJ.EQ.1) IP=L PANEL+IQ+1	STM 600
	IF (NNJ.NE.1) IP=MJJ(N1)+IQ+1	STM 610
	DO 90 JJ=1,MF	STM 620
	IF (JJ.EQ.MF) GO TO 70	STM 630
	DXTH=DLX*PSI(JJ)*TEMP*VMU*VMU/TH	STM 640
	GO TO 80	STM 650
70	DXTH=DLX*PSI(JJ)*TEMP*0.5*VMU*VMU/TH	STM 660
80	JK1=IP+JJ	STM 670
	JK2=JK1-1	STM 680
	PROD=SZX*DXTH	STM 690
	JK3=JK2+NP*NCJ(NNJ)	STM 700
	ALPHA=ALPHA+PROD*(PHIN(JK2)-PHIN(JK3))	STM 710
90	CONTINUE	STM 720
	GO TO 220	STM 730
100	CONTINUE	STM 740
	IJ=I-JPANEL	STM 750
	IF (KCODE.EQ.0) GO TO 200	STM 760
	IF (EXIT.LE.0.01) GO TO 110	STM 770
	IF (NNJ.EQ.1) GO TO 110	STM 780
	IF (IJ.GT.LPANEL.AND.IJ.LE.MJJ(1)) GO TO 220	STM 790
110	CONTINUE	STM 800
	IF (IUSR.EQ.1.AND.ZJET.GT.0.01) GO TO 200	STM 810
	IF (NNJ.EQ.1) GO TO 200	STM 820
	IF (IJ.GT.MJJ(N1)) GO TO 200	STM 830
	IF (IPHI.LE.NJH) GO TO 200	STM 840
	L1=NJH	STM 850
	IF (ISYM.EQ.0) L1=NJH+1	STM 860
	IF (NW(2).EQ.0) GO TO 130	STM 870
	IF (NW(3).EQ.0) GO TO 120	STM 880
	IF (IJ.GT.MJJ(N2)) GO TO 160	STM 890
	IF (IJ.GT.MJJ(N3)) GO TO 150	STM 900
	IF (NNJ.EQ.4) GO TO 140	STM 910
	IF (NNJ.EQ.5.AND.IJ.GT.MJJ(NNJ-4)) GO TO 140	STM 920
	GO TO 200	STM 930
120	IF (IJ.GT.MJJ(N2)) GO TO 150	STM 940
	IF (NNJ.EQ.3) GO TO 140	STM 950
	IF (NNJ.EQ.4.AND.IJ.GT.MJJ(N3)) GO TO 140	STM 960
	GO TO 200	STM 970
130	IF (NNJ.EQ.2) GO TO 140	STM 980
	IF (NNJ.EQ.3.AND.IJ.GT.MJJ(N2)) GO TO 140	STM 990
	GO TO 200	STM1000
140	K1=MJW1(1,NJP)+(IPHI-L1-ISYM)*NW(1)-1	STM1010
	K2=LC(1)+IPHI-L1-ISYM	STM1020
	KNW=NW(1)	STM1030
	GO TO 170	STM1040
150	K1=MJW1(2,NJP)+(IPHI-L1-ISYM)*NW(2)-1	STM1050
	K2=LC(2)+IPHI-L1-ISYM	STM1060
	KNW=NW(2)	STM1070
	GO TO 170	STM1080

160	K1=MJW1(3,NJP)+(IPHI-L1-ISYM)*NW(3)-1	STM1090
	K2=LC(3)+IPHI-L1-ISYM	STM1100
	KNW=NW(3)	STM1110
170	CONTINUE	STM1120
	ALPHA1=0.	STM1130
	ALPHA2=0.	STM1140
	DO 190 KK=1,KNW	STM1150
	KL=K1+KK	STM1160
	AA=1.	STM1170
	DO 180 L=1,KNW	STM1180
	LL=K1+L	STM1190
	IF (L.EQ.KK) GO TO 180	STM1200
	AA=AA*(XCP(IJ)-XV(LL))/(XV(KL)-XV(LL))	STM1210
180	CONTINUE	STM1220
	ALPHA1=ALPHA1+AA*GAM(1,KL)	STM1230
	IF (ABS(B1-B2).LE.0.001) GO TO 190	STM1240
	ALPHA2=ALPHA2+AA*GAM(2,KL)	STM1250
190	CONTINUE	STM1260
	IF (ABS(B1-B2).LE.0.001) ALPHA2=ALPHA1	STM1270
	ALPHA=(ALPHA2-TEMP*VMU*VMU*ALPHA1)*0.5	STM1280
	GO TO 220	STM1290
200	CONTINUE	STM1300
	CALL SPEED (VMU,I,ALPHA,LPANEL,TEMP,LPAN1,LPAN2,PHIS,IPHI,ISYM)	STM1310
	IF (KCODE.EQ.0) GO TO 220	STM1320
	IF (CDF.LT.0.0001) GO TO 220	STM1330
	IF (NNJ.EQ.1) GO TO 210	STM1340
	IF (IJ.LE.MJJ(N1)) GO TO 220	STM1350
210	PHIN(IJ)=PHIS	STM1360
220	CONTINUE	STM1370
	RETURN	STM1380
C	END	STM1390
	SUBROUTINE SPEED (VMU,I,ALPHA,LPANEL,TEMP,LPAN1,LPAN2,PHIS,IPHI,ISSPD	STM1400-
	1YM)	SPD 10
C	TO COMPUTE THE INDUCED TANGENTIAL VELOCITIES DUE TO WING ALONE	SPD 20
C	VORTICES	SPD 30
	DIMENSION SU(100)	SPD 40
	COMMON /SCHEME/ C(2),X(10,41),Y(10,41),SLOPE(15),XL(2,15),XTT(41),SPD	SPD 50
	1XLL(41)	SPD 60
	COMMON /GEOM/ HALFSW,XCP(200),YCP(200),ZCP(200),XLE(50),YLE(50),XTSPD	SPD 70
	IF(50),PSI(20),CH(95),XV(200),YV(100),SN(8,8),XN(200,2),YN(200,2),ZSPD	SPD 80
	2N(200,2),WIDTH(8),YCON(25),SWEEP(50),HALFB,SJ(21,8),EX(95,2),TX(95SPD	SPD 90
	3,2),SC(160,5),SI(160,5),LC(3)	SPD 100
	COMMON /AERO/ AM1,AM2,B1,B2,CL(30),CT(30),CD(30),GAM(2,100)	SPD 110
	COMMON /CONST/ NCS,NCW,M1(8),NSJ,NCJ(5),LAST,MJW1(3,5),MJW2(3,5),JSPD	SPD 120
	1PANEL,MJJ(5),NW(3),NNJ,NJP	SPD 130
	N1=NNJ-1	SPD 140
	N2=NNJ-2	SPD 150
		SPD 160

	N3=NNJ-3	SPD 170
	ZJET=YCON(25)	SPD 180
	II=I-JPANEL	SPD 190
	BB=B1	SPD 200
	IC=1	SPD 210
10	CONTINUE	SPD 220
	IZ=1	SPD 230
	MM=0	SPD 240
	ISN=1	SPD 250
	NL=NW(1)	SPD 260
	NM=NW(1)	SPD 270
	B=0.	SPD 280
	DO 70 J=1,LPANEL	SPD 290
	JJ=J-MM	SPD 300
	FN=NL	SPD 310
	IF (J.GT.LPAN1.AND.J.LE.LPAN2) ISN=2	SPD 320
	IF (J.GT.LPAN2.AND.J.LE.LPANEL) ISN=3	SPD 330
	IF (J.GE.LPAN1.AND.J.LT.LPANEL) GO TO 20	SPD 340
	GO TO 30	SPD 350
20	NL=NW(2)	SPD 360
	IF (J.GE.LPAN2.AND.J.LT.LPANEL) NL=NW(3)	SPD 370
30	CONTINUE	SPD 380
	X1=XN(J,1)-XCP(II)	SPD 390
	X2=XN(J,2)-XCP(II)	SPD 400
	X12=XN(J,2)-XN(J,1)	SPD 410
	Y12=YN(J,2)-YN(J,1)	SPD 420
	Z1=-ZCP(II)	SPD 430
	Z2=-ZCP(II)	SPD 440
	Z12=0.	SPD 450
	XZJ=-Z1*X12	SPD 460
	DO 60 K=1,2	SPD 470
	IF (K.EQ.1) GO TO 40	SPD 480
	N=1	SPD 490
	GO TO 50	SPD 500
40	N=2	SPD 510
50	CONTINUE	SPD 520
	YC=(-1.)**N*YCP(II)	SPD 530
	Y1=YN(J,1)-YC	SPD 540
	Y2=YN(J,2)-YC	SPD 550
	XYK=X1*Y12-Y1*X12	SPD 560
	YZI=-Z1*Y12	SPD 570
	ALB1=XYK*XYK+XZJ*XZJ+BB*YZI*YZI	SPD 580
	R1B1=SQRT(X1*X1+BB*Y1*Y1+BB*Z1*Z1)	SPD 590
	R2B1=SQRT(X2*X2+BB*Y2*Y2+BB*Z2*Z2)	SPD 600
	UUB1=(X2*X12+BB*Y2*Y12+BB*Z2*Z12)/R2B1-(X1*X12+BB*Y1*Y12+BB*Z1*Z12)	SPD 610
	1)/R1B1	SPD 620
	F1=UUB1*YZI/ALB1	SPD 630
	SUM=F1*CH(IZ)*SN(JJ,ISN)*GAM(IC,J)/FN	SPD 640
	IF (K.EQ.1) SU(J)=F1*CH(IZ)*SN(JJ,ISN)/FN	SPD 650

60	R=B+SUM	SPD 660
	IF (J.LT.NM) GO TO 70	SPD 670
	IZ=IZ+1	SPD 680
	MM=NM	SPD 690
	NM=NM+NL	SPD 700
70	CONTINUE	SPD 710
	NJH=(NSJ+1)/2+1	SPD 720
	IF (ISYM.EQ.0) NJH=NSJ/2	SPD 730
	IF (IPHI.EQ.NJH) GO TO 140	SPD 740
	IF (ISYM.NE.0.AND.IPHI.EQ.1) GO TO 140	SPD 750
	IF (NNJ.EQ.1) GO TO 140	SPD 760
	IF (II.GT.MJJ(N1)) GO TO 140	SPD 770
	IF (IPHI.GT.NJH.AND.ZJET.LE.0.01) GO TO 140	SPD 780
	IF (IPHI.GT.NJH) L1=NJH	SPD 790
	IF (ISYM.EQ.0.AND.IPHI.GT.NJH) L1=NJH+1	SPD 800
	IF (IPHI.LE.NJH) L1=1	SPD 810
	N7=1	SPD 820
	IF (NW(2).NE.0.AND.NW(3).EQ.0) NZ=2	SPD 830
	IF (NW(3).NE.0) NZ=3	SPD 840
	IF (NNJ.LE.3.AND.NW(2).NE.0) IR=N2	SPD 850
	IF (NNJ.LE.3.AND.NW(2).EQ.0) IR=N1	SPD 860
	IF (NNJ.GE.4.AND.NW(3).NE.0) IR=N3	SPD 870
	IF (NNJ.EQ.4.AND.NW(3).EQ.0) IR=N2	SPD 880
	DO 130 MP=1,NZ	SPD 890
	K1=MJW1(MP,NJP)+(IPHI-L1-ISYM)*NW(MP)-1	SPD 900
	K2=LC(MP)+IPHI-L1-ISYM	SPD 910
	KNW=NW(MP)	SPD 920
	K1=K1-KNW	SPD 930
	K2=K2-1	SPD 940
	MR=3	SPD 950
	IF (K1.GE.0) GO TO 80	SPD 960
	K1=K1+KNW	SPD 970
	K2=K2+1	SPD 980
	MR=2	SPD 990
80	DO 120 NR=1,MR	SPD1000
	SUM=0.	SPD1010
	DO 90 KK=1,KNW	SPD1020
	KL=K1+KK	SPD1030
90	SUM=SUM+SU(KL)	SPD1040
	CALL INTEG (RES,KNW,K1,K2,II,BB,IR)	SPD1050
	CORN=0.	SPD1060
	DO 110 KK=1,KNW	SPD1070
	KL=K1+KK	SPD1080
	AA=1.	SPD1090
	DO 100 L=1,KNW	SPD1100
	LL=K1+L	SPD1110
	IF (L.EQ.KK) GO TO 100	SPD1120
	AA=AA*(XCP(II)-XV(LL))/(XV(KL)-XV(LL))	SPD1130
100	CONTINUE	SPD1140
110	CORN=CORN+AA*GAM(IC,KL)	SPD1150

	B=B-CORN*SUM+CORN*RES*8.	SPD1160
	K1=K1+KNW	SPD1170
	K2=K2+1	SPD1180
120	CONTINUE	SPD1190
	IR=IR+1	SPD1200
130	CONTINUE	SPD1210
140	CONTINUE	SPD1220
	IF (IC.EQ.2) GO TO 150	SPD1230
	ALPHA1=B/8.	SPD1240
	IC=IC+1	SPD1250
	B4=B2	SPD1260
	IF (ABS(B1-B2).LE.0.001) GO TO 160	SPD1270
	GO TO 10	SPD1280
150	ALPHA2=B/8.	SPD1290
	GO TO 170	SPD1300
160	ALPHA2=ALPHA1	SPD1310
170	ALPHA=ALPHA2-TEMP*VMU*VMU*ALPHA1	SPD1320
	PHIS=ALPHA2	SPD1330
	RETURN	SPD1340
C		SPD1350
	END	SPD1360-
	SUBROUTINE THRUST (LTOTAL,LPANEL,GAMMA,CAM,LPAN1,VMU,XJ,YJ,ZJ,RJ,TTHR	THR 10
	1,GAL,ISYM,LPAN2,CAMLET)	THR 20
C	TO EVALUATE THE LEADING EDGE THRUST	THR 30
	DIMENSION GAMMA(1), GAL(1)	THR 40
	COMMON /SCHEME/ C(2),X(10,41),Y(10,41),SLOPE(15),XL(2,15),XTT(41),THR	THR 50
	1XLL(41)	THR 60
	COMMON /GEOM/ HALFSW,XCP(200),YCP(200),ZCP(200),XLE(50),YLE(50),XTTHR	THR 70
	1E(50),PSI(20),CH(95),XV(200),YV(100),SN(8,8),XN(200,2),YN(200,2),ZTHR	THR 80
	2N(200,2),WIDTH(8),YCON(25),SWEEP(50),HALFB,SJ(21,8),EX(95,2),TX(95THR	THR 90
	3,2),SC(160,5),SI(160,5),LC(3)	THR 100
	COMMON /AERO/ AM1,AM2,B1,B2,CL(30),CT(30),CD(30),GAM(2,100)	THR 110
	COMMON /CONST/ NCS,NCW,M1(8),NSJ,NCJ(5),LAST,MJW1(3,5),MJW2(3,5),JTHR	THR 120
	1PANEL,MJJ(5),NW(3),NNJ,NJP	THR 130
	COMMON /PARAM/ ALPT,ALPC,ALPS,CDF,SDF,TH,TDF	THR 140
	PJ=3.14159265	THR 150
	CAMLER=CAM	THR 160
	CN=NW(1)	THR 170
	IUSB=YCON(24)	THR 180
	ITN=YCON(23)	THR 190
	DO 200 I=1,NCS	THR 200
	FCOS=COS(SWEEP(I))	THR 210
	FTAN=TAN(SWEEP(I))	THR 220
	NK=I*NW(1)	THR 230
	IF (NW(2).EQ.0) GO TO 20	THR 240
	IJ=I+NCS	THR 250
	IF (NW(3).NE.0) GO TO 10	THR 260
	CHL=CH(I)+CH(IJ)	THR 270
	GO TO 30	THR 280

REPRODUCIBILITY OF THE
ORIGINAL PAGE IS FROM

10	III=II+NCS	THR 290
	CHL=CH(I)+CH(II)+CH(III)	THR 300
	GO TO 30	THR 310
20	CHL=CH(I)	THR 320
30	CONTINUE	THR 330
	SPT=SQRT(CH(I)/CHL)	THR 340
	BB=B1	THR 350
	IC=1	THR 360
	IZ=1	THR 370
	MM=0	THR 380
	ISN=1	THR 390
	NM=NW(1)	THR 400
	NL=NW(1)	THR 410
	RC=0.	THR 420
	A=0.	THR 430
	DO 90 NN=1,LPANEL	THR 440
	J=NN-MM	THR 450
	FN=NL	THR 460
	IF (NN.GE.LPAN1.AND.NN.LT.LPANEL) GO TO 40	THR 470
	GO TO 50	THR 480
40	NL=NW(2)	THR 490
	IF (NN.GE.LPAN2.AND.NN.LT.LPANEL) NL=NW(3)	THR 500
	IF (NN.GT.LPAN1.AND.NN.LE.LPAN2) ISN=2	THR 510
	IF (NN.GT.LPAN2.AND.NN.LE.LPANEL) ISN=3	THR 520
50	CONTINUE	THR 530
	X1=XN(NN,1)-XLE(I)	THR 540
	X2=XN(NN,2)-XLE(I)	THR 550
	X12=XN(NN,2)-XN(NN,1)	THR 560
	Y12=YN(NN,2)-YN(NN,1)	THR 570
	DO 80 K=1,2	THR 580
	IF (K.EQ.1) GO TO 60	THR 590
	N1=1	THR 600
	GO TO 70	THR 610
60	N1=2	THR 620
70	CONTINUE	THR 630
	YC=YLE(I)*(-1.)**N1	THR 640
	Y1=YN(NN,1)-YC	THR 650
	Y2=YN(NN,2)-YC	THR 660
	XYK=X1*Y12-Y1*X12	THR 670
	R1=SQRT(X1*X1+BB*Y1*Y1)	THR 680
	R2=SQRT(X2*X2+BB*Y2*Y2)	THR 690
	U1=(X12*X2+BB*Y12*Y2)/R2-(X12*X1+BB*Y12*Y1)/R1	THR 700
	U1=U1/XYK	THR 710
	U2=(1.-X1/R1)/Y1	THR 720
	U3=(1.-X2/R2)/Y2	THR 730
	RC=RC+(U1+U2-U3)*SN(J,ISN)*GAM(2,NN)*CH(IZ)/FN	THR 740
80	A=A+(U1+U2-U3)*SN(J,ISN)*GAM(IC,NN)*CH(IZ)/FN	THR 750
	IF (NN.LT.NM.OR.NN.EQ.LPANEL) GO TO 90	THR 760
	IZ=IZ+1	THR 770

	MM=NM	THR 780
	NM=NM+NL	THR 790
90	CONTINUE	THR 800
	CAMLE=CAMLER-(CAMLER-CAMLET)*YLE(I)/HALFB	THR 810
	A=A/8.+XTT(I)-CAMLE	THR 820
	XB=XLE(I)	THR 830
	YB=YLE(I)	THR 840
	PHRV=0.	THR 850
	IF (IUSB.EQ.1.AND.ITN.EQ.0) GO TO 100	THR 860
	CALL INDVEL (XB,YB,XJ,YJ,ZJ,RJ,B1,PHRV,PHX,T,VMU,PHY,ISYM)	THR 870
100	CONTINUE	THR 880
	A=A+PHRV/(ALPC*VMU)	THR 890
	A=A*SRT	THR 900
	THRT1=A/(CN*SQRT(FTAN*FTAN+BB))	THR 910
	XTE(I)=(PI/2.)*SQRT(1.-AM1*AM1*FCOS*FCOS)*THRT1*THRT1/FCOS	THR 920
	RC=BC/8.+XTT(I)-CAMLE	THR 930
	BC=RC*SRT	THR 940
	THR=BC/(CN*SQRT(FTAN*FTAN+BB))	THR 950
	X(5,I)=(PI/2.)*SQRT(1.-AM1*AM1*FCOS*FCOS)*THR*THR/FCOS	THR 960
	NM=NW(1)	THR 970
	IND=1	THR 980
	ISN=1	THR 990
	L1=LPANEL+1	THR1000
	SK=1.	THR1010
	IZ=1	THR1020
	MM=0	THR1030
	II=NW(1)	THR1040
	A=0.	THR1050
	FACTOR=1.	THR1060
	AM=AM1	THR1070
	BR=B1	THR1080
	CONV=ALPC	THR1090
	DO 190 NN=1, LAST	THR1100
	IF (NN.GT.LPANEL) NA=NN-LPANEL+JPANEL	THR1110
	IF (NN.LE.LPANEL) NA=NN+2*JPANEL	THR1120
	FN=II	THR1130
	IF (NN.GT.LPAN1.AND.NN.LE.LPAN2) ISN=2	THR1140
	IF (NN.GT.LPAN2.AND.NN.LE.LPANEL) ISN=3	THR1150
	IF (NN.GE.LPAN1.AND.NN.LT.LPANEL) GO TO 110	THR1160
	GO TO 120	THR1170
110	II=NW(2)	THR1180
	IF (NN.GE.LPAN2.AND.NN.LT.LPANEL) II=NW(3)	THR1190
120	CONTINUE	THR1200
	IF (NN.GE.LPANEL.AND.NN.LT.MJJ(IND)) II=NCJ(IND)	THR1210
	J=NN-MM	THR1220
	CHORD=CH(IZ)	THR1230
	IF (NN.EQ.L1) GO TO 130	THR1240
	GO TO 140	THR1250
130	ISN=ISN+1	THR1260

	L1=MJJ(IND)+1	THR1270
140	NL=MJJ(IND)-1	THR1280
	IF (NN.EQ.NL) IND=IND+1	THR1290
	IF (NN.GT.LPANEL) FACTOR=0.5	THR1300
	X1=XN(NN,1)-XLE(I)	THR1310
	X2=XN(NN,2)-XLE(I)	THR1320
	X12=XN(NN,2)-XN(NN,1)	THR1330
	Y12=YN(NN,2)-YN(NN,1)	THR1340
	Z12=ZN(NN,2)-ZN(NN,1)	THR1350
	XZJ=X1*Z12-ZN(NN,1)*X12	THR1360
	DO 170 K=1,2	THR1370
	IF (K.EQ.1) GO TO 150	THR1380
	N1=1	THR1390
	GO TO 160	THR1400
150	N1=2	THR1410
160	CONTINUE	THR1420
	YC=YLE(I)*(-1.)**N1	THR1430
	Y1=YN(NN,1)-YC	THR1440
	Y2=YN(NN,2)-YC	THR1450
	XYK=X1*Y12-Y1*X12	THR1460
	YZI=Y1*Z12-ZN(NN,1)*Y12	THR1470
	ALPRIM=XYK*XYK+XZJ*XZJ+BB*YZI*YZI	THR1480
	RXYZ1=SQRT(X1*X1+BB*Y1*Y1+BB*ZN(NN,1)*ZN(NN,1))	THR1490
	RXYZ2=SQRT(X2*X2+BB*Y2*Y2+BB*ZN(NN,2)*ZN(NN,2))	THR1500
	UU=(X2*X12+BB*Y2*Y12+BB*ZN(NN,2)*Z12)/RXYZ2-	THR1510
	1 N(NN,1)*Z12)/RXYZ1	THR1520
	GN1=(1.-X1/RXYZ1)/(Y1*Y1+ZN(NN,1)*ZN(NN,1))	THR1530
	GN2=(1.-X2/RXYZ2)/(Y2*Y2+ZN(NN,2)*ZN(NN,2))	THR1540
	F1=UU*XYK/ALPRIM*SK	THR1550
	F2=(GN1*Y1-GN2*Y2)*SK	THR1560
170	A=A+(F1+F2)*SN(J,ISN)*CHORD*GAMMA(NA)/(B.*FN*FACTOR)	THR1570
	IF (NN.LT.NM) GO TO 180	THR1580
	IZ=IZ+1	THR1590
	MM=NM	THR1600
	NM=NM+1	THR1610
180	CONTINUE	THR1620
190	CONTINUE	THR1630
	A=A*SRT	THR1640
	THRT2=A/(CN*SQRT(FTAN*FTAN+BB))	THR1650
	THRT=(THRT1+THRT2)*CONV	THR1660
	GAL(I)=2.*THRT/(SRT*CONV)	THR1670
	CT(I)=(PI/2.)*SQRT(1.-AM*AM*FCOS*FCOS)*THRT*THRT/FCOS	THR1680
200	CONTINUE	THR1690
	RETURN	THR1700
	END	THR1710-
	SUBROUTINE NORSPD (I,ALPH,LPANEL,IPHI,LPAN1,LPAN2)	NOR 10
C	TO COMPUTE THE INDUCED NORMAL VELOCITIES DUE TO WING ALONE	NOR 20
C	VORTICES	NOR 30
	COMMON /SCHEMF/ C(2),X(10,41),Y(10,41),SLOPE(15),XL(2,15),XTT(41),NOR	NOR 40

	1XLL(41)	NOR	50
	COMMON /GEOM/ HALFSW,XCP(200),YCP(200),ZCP(200),XLE(50),YLE(50),XTNOR	NOR	60
	IE(50),PSI(20),CH(95),XV(200),YV(100),SN(8,8),XN(200,2),YN(200,2),ZNOR	NOR	70
	2N(200,2),WIDTH(8),YCON(25),SWEEP(50),HALFB,SJ(21,8),EX(95,2),TX(95NOR	NOR	80
	3,2),SC(160,5),SI(160,5),LC(3)	NOR	90
	COMMON /AERO/ AM1,AM2,B1,B2,CL(30),CT(30),CD(30),GAM(2,100)	NOR	100
	COMMON /CONST/ NCS,NCW,M1(8),NSJ,NCJ(5),LAST,MJW1(3,5),MJW2(3,5),JNOR	NOR	110
	1PANEL,MJJ(5),NW(3),NNJ,NJP	NOR	120
	NJH=(NSJ-1)/2	NOR	130
	IZ=1	NOR	140
	MM=0	NOR	150
	MM=NW(1)	NOR	160
	ISN=1	NOR	170
	NL=NW(1)	NOR	180
	A1=0.	NOR	190
	A2=0.	NOR	200
	DO 60 J=1,LPANEL	NOR	210
	JJ=J-MM	NOR	220
	FN=NL	NOR	230
	IF (J.GT.LPAN1.AND.J.LE.LPAN2) ISN=2	NOR	240
	IF (J.GT.LPAN2.AND.J.LE.LPANEL) ISN=3	NOR	250
	IF (J.GE.LPAN1.AND.J.LT.LPANEL) GO TO 10	NOR	260
	GO TO 20	NOR	270
10	NL=NW(2)	NOR	280
20	IF (J.GE.LPAN2.AND.J.LT.LPANEL) NL=NW(3)	NOR	290
	CONTINUE	NOR	300
	X1=XN(J,1)-XCP(I)	NOR	310
	X2=XN(J,2)-XCP(I)	NOR	320
	X12=XN(J,2)-XN(J,1)	NOR	330
	Y12=YN(J,2)-YN(J,1)	NOR	340
	Z12=0.	NOR	350
	Z1=-ZCP(I)	NOR	360
	Z2=-ZCP(I)	NOR	370
	XZJ=X1*Z12-Z1*X12	NOR	380
	DO 50 K=1,2	NOR	390
	IF (K.EQ.1) GO TO 30	NOR	400
	N=1	NOR	410
	GO TO 40	NOR	420
30	N=2	NOR	430
40	CONTINUE	NOR	440
	YC=(-1.)**N*YCP(I)	NOR	450
	Y1=YN(J,1)-YC	NOR	460
	Y2=YN(J,2)-YC	NOR	470
	XYK=X1*Y12-Y1*X12	NOR	480
	YZI=Y1*Z12-Z1*Y12	NOR	490
	ALB1=XYK*XYK+XZJ*XZJ+B1*YZI*YZI	NOR	500
	R1B1=SQRT(X1*X1+B1*Y1*Y1+B1*Z1*Z1)	NOR	510
	R2B1=SQRT(X2*X2+B1*Y2*Y2+B1*Z2*Z2)	NOR	520
	UUR1=(X2*X12+B1*Y2*Y12+B1*Z2*Z12)/R2B1-(X1*X12+B1*Y1*Y12+B1*Z1*Z12)NOR	NOR	530

	1)/R1B1	NOR 540
	G1=(1.-X1/R1B1)/(Y1*Y1+Z1*Z1)	NOR 550
	G2=(1.-X2/R2B1)/(Y2*Y2+Z2*Z2)	NOR 560
	ALB2=XYK*XYK+XZJ*XZJ+B2*YZI*YZI	NOR 570
	R1B2=SQRT(X1*X1+B2*Y1*Y1+B2*Z1*Z1)	NOR 580
	R2B2=SQRT(X2*X2+B2*Y2*Y2+B2*Z2*Z2)	NOR 590
	UUB2=(X2*X12+B2*Y2*Y12+B2*Z2*Z12)/R2B2-(X1*X12+B2*Y1*Y12+B2*Z1*Z12)	NOR 600
	1)/R1B2	NOR 610
	G3=(1.-X1/R1B2)/(Y1*Y1+Z1*Z1)	NOR 620
	G4=(1.-X2/R2B2)/(Y2*Y2+Z2*Z2)	NOR 630
	F13=UUB1*XZJ/ALB1	NOR 640
	F12=UUB1*XYK/ALB1	NOR 650
	G13=Z2*G2-Z1*G1	NOR 660
	G12=-Y2*G2+Y1*G1	NOR 670
	F23=UUB2*XZJ/ALB2	NOR 680
	F22=UUB2*XYK/ALB2	NOR 690
	G23=Z2*G4-Z1*G3	NOR 700
	G22=-Y2*G4+Y1*G3	NOR 710
	F1=-F13*Y(4,IPHI)*(-1.)*N+F12*Y(3,IPHI)	NOR 720
	F2=G13*Y(4,IPHI)*(-1.)*N+G12*Y(3,IPHI)	NOR 730
	F3=-F23*Y(4,IPHI)*(-1.)*N+F22*Y(3,IPHI)	NOR 740
	F4=G23*Y(4,IPHI)*(-1.)*N+G22*Y(3,IPHI)	NOR 750
	A1=A1+(F1+F2)*CH(IZ)*SN(JJ,ISN)*GAM(1,J)/FN	NOR 760
50	A2=A2+(F3+F4)*CH(IZ)*SN(JJ,ISN)*GAM(2,J)/FN	NOR 770
	IF (J.LT.NM) GO TO 60	NOR 780
	I7=I7+1	NOR 790
	MM=NM	NOR 800
	NM=NM+NL	NOR 810
60	CONTINUE	NOR 820
	ALPH=(A1-A2)/8.	NOR 830
	RETURN	NOR 840
	END	NOR 850-
	OVERLAY(USBOWB,5,0)	
	PROGRAM LOAD	LOD 10
C	TO EVALUATE THE AERODYNAMIC CHARACTERISTICS	LOD 20
	DIMENSION CA(30), CPSWL(30), AW(30)	LOD 30
	COMMON /GEOM/ HALFSW,XCP(200),YCP(200),ZCP(200),XLE(50),YLE(50),XTLOD	LOD 40
	1E(50),PSI(20),CH(95),XV(200),YV(100),SN(8,8),XN(200,2),YN(200,2),ZLOD	LOD 50
	2N(200,2),WIDTH(8),YCON(25),SWEEP(50),HALFR,SJ(21,8),EX(95,2),TX(95LOD	LOD 60
	3,2),SC(160,5),SI(160,5),LC(3)	LOD 70
	COMMON /AERO/ AM1,AM2,B1,B2,CL(30),CT(30),CD(30),GAM(2,100)	LOD 80
	COMMON /CONST/ NCS,NCW,M1(8),NSJ,NCJ(5),LAST,MJW1(3,5),MJW2(3,5),JLOD	LOD 90
	IPANEL,MJJ(5),NW(3),NNJ,NJP	LOD 100
	COMMON /PARAM/ ALPT,ALPC,ALPS,CDF,SDF,TH,TDF	LOD 110
	COMMON /SCHEME/ C(2),X(10,41),Y(10,41),SLOPE(15),XL(2,15),XTT(41),LOD	LOD 120
	1XLL(41)	LOD 130
	COMMON /ADD/ CP(100),CM(30),BREAK(8),SWP(8,15),GAL(30),ISYM,VMU,VULOD	LOD 140
	1,TEMP,FCR,CAMLER,CAMLET,CAMTER,CAMTET,XJ,YJ,ZJ,RJ,ALP,CREF,TWISTR	LOD 150
	COMMON /COST/ LTOTAL,LPAN1,NJW(5),LPANEL,IENTN,LPAN2,EXIT,PTIAL,TWLOD	LOD 160

	IIST,DF(5),NFP	LOD 170
	PI=3.14159265	LOD 180
	ALPH=ALP*180./PI	LOD 190
	WRITE (6,330)	LOD 200
	WRITE (6,320) ALPH	LOD 210
	WRITE (6,330)	LOD 220
	ZJET=YCON(25)	LOD 230
	IUSB=YCON(24)	LOD 240
	NC=IENTN	LOD 250
	DFJ=CDF	LOD 260
	CMU=C(1)	LOD 270
	CLT=0.	LOD 280
	CMT=0.	LOD 290
	CDT=0.	LOD 300
	CLW=0.	LOD 310
	CMWT=0.	LOD 320
	CDW=0.	LOD 330
	CLWW=0.	LOD 340
	CMWWT=0.	LOD 350
	CDWW=0.	LOD 360
	KC=1	LOD 370
	NCOL=M1(1)	LOD 380
	KLL=0	LOD 390
	MM=0	LOD 400
	TU=1	LOD 410
	IF (NW(2),NE.0) IU=2	LOD 420
	IF (NW(3),NE.0) IU=3	LOD 430
	NW2=NW(1)+NW(2)	LOD 440
	NW3=NW(2)+NW(3)	LOD 450
	NCW1=NCW+1	LOD 460
	NL=1	LOD 470
	DO 140 I=1,NCS	LOD 480
	IF (NW(2),EQ.0) GO TO 20	LOD 490
	II=I+NCS	LOD 500
	IF (NW(3),NE.0) GO TO 10	LOD 510
	CHORD=CH(I)+CH(II)	LOD 520
	GO TO 30	LOD 530
10	III=II+NCS	LOD 540
	CHORD=CH(I)+CH(II)+CH(III)	LOD 550
	GO TO 30	LOD 560
20	CHORD=CH(I)	LOD 570
30	CONTINUE	LOD 580
	CML=0.	LOD 590
	CL(I)=0.	LOD 600
	CD(I)=0.	LOD 610
	CA(I)=0.	LOD 620
	CMW=0.	LOD 630
	CPSWL(I)=0.	LOD 640
	CMWW=0.	LOD 650
	X(4,I)=0.	LOD 660

	X(6,I)=0.	LOD 670
	X(7,I)=0.	LOD 680
	DO 120 J=1,NCW	LOD 690
	NN=J+MM	LOD 700
	IF (NW(2).EQ.0) GO TO 50	LOD 710
	IF (J.LE.NW(1)) GO TO 50	LOD 720
	IF (J.GT.NW2) GO TO 40	LOD 730
	LL=LPAN1+NW(2)*(I-1)+J-NW(1)	LOD 740
	IL=II	LOD 750
	JLL=J-NW(1)	LOD 760
	L=2	LOD 770
	FN=NW(2)	LOD 780
	GO TO 60	LOD 790
40	LL=LPAN2+NW(3)*(I-1)+J-NW2	LOD 800
	IL=III	LOD 810
	JLL=J-NW2	LOD 820
	L=3	LOD 830
	FN=NW(3)	LOD 840
	GO TO 60	LOD 850
50	LL=NN	LOD 860
	IL=I	LOD 870
	JLL=J	LOD 880
	L=1	LOD 890
	FN=NW(1)	LOD 900
60	CONTINUE	LOD 910
	XC=(XV(LL)-XLE(I))/CHORD	LOD 920
	X(1,J)=ZCR(XC)	LOD 930
	X(2,J)=ZCT(XC)	LOD 940
	GRS=CP(LL)*SN(JLL,L)*CH(IL)/(2.*FN)	LOD 950
	WBS=GAM(1,LL)*SN(JLL,L)*CH(IL)*ALPC/FN	LOD 960
	WAS=GAM(2,LL)*SN(JLL,L)*CH(IL)*ALPC/FN	LOD 970
	IF (DF(NL).LE.0.001) GO TO 70	LOD 980
	IF (PTIAL.LE.0.1) GO TO 80	LOD 990
	IF (NW(3).EQ.0) GO TO 100	LOD1000
	IF (LL.GE.MJW1(3,NL).AND.LL.LE.MJW2(3,NL)) GO TO 90	LOD1010
70	CAM=X(1,J)-(X(1,J)-X(2,J))*YV(LL)/HALFB	LOD1020
	EPHA=XLL(I)-ATAN(CAM)	LOD1030
	CS=COS(EPHA)	LOD1040
	SS=SIN(EPHA)	LOD1050
	GO TO 110	LOD1060
80	IF (NW(2).NE.0.AND.LL.LE.LPAN1) GO TO 70	LOD1070
	IF (NW(3).NE.0.AND.LL.LE.LPAN2) GO TO 70	LOD1080
90	EP=XLL(I)+DF(NL)	LOD1090
	CAM=X(1,J)-(X(1,J)-X(2,J))*YV(LL)/HALFB	LOD1100
	EP=EP-ATAN(CAM)	LOD1110
	CS=COS(EP)	LOD1120
	SS=SIN(EP)	LOD1130
	GO TO 110	LOD1140
100	IF (LL.GE.MJW1(2,NL).AND.LL.LE.MJW2(2,NL)) GO TO 90	LOD1150
	GO TO 70	LOD1160
110	CONTINUE	LOD1170

	CL(I)=CL(I)+GBS*CS	LOD1180
	CML=CML-GBS*XV(LL)*CS	LOD1190
	CD(I)=CD(I)+GBS*SS	LOD1200
	CA(I)=CA(I)+WBS*CS	LOD1210
	CMW=CMW-WBS*XV(LL)*CS	LOD1220
	CPSWL(I)=CPSWL(I)+WBS*SS	LOD1230
	X(4,I)=X(4,I)+WAS*CS	LOD1240
	CMWW=CMWW-WAS*XV(LL)*CS	LOD1250
	X(6,I)=X(6,I)+WAS*SS	LOD1260
120	CONTINUE	LOD1270
	CAMLE=CAMLER-(CAMLER-CAMLET)*YLE(I)/HALFB	LOD1280
	EPHA=XLL(I)-ATAN(CAMLE)	LOD1290
	X(1,NCW1)=COS(EPHA)	LOD1300
	X(2,NCW1)=SIN(EPHA)	LOD1310
	CL(I)=CL(I)*PI/CHORD+CT(I)*X(2,NCW1)	LOD1320
	CM(I)=CML*PI/(CREF*CHORD)	LOD1330
	CD(I)=CD(I)*PI/CHORD-CT(I)*X(1,NCW1)	LOD1340
	CA(I)=CA(I)*PI/CHORD+XTE(I)*X(2,NCW1)	LOD1350
	AW(I)=CMW*PI/(CREF*CHORD)	LOD1360
	CPSWL(I)=CPSWL(I)*PI/CHORD-XTE(I)*X(1,NCW1)	LOD1370
	X(4,I)=X(4,I)*PI/CHORD+X(5,I)*X(2,NCW1)	LOD1380
	X(7,I)=CMWW*PI/(CREF*CHORD)	LOD1390
	X(6,I)=X(6,I)*PI/CHORD-X(5,I)*X(1,NCW1)	LOD1400
	IF(I.LT.NCOL) GO TO 130	LOD1410
	KLL=NCOL-1	LOD1420
	KC=KC+1	LOD1430
	NCOL=NCOL+M1(KC)-1	LOD1440
130	KL=I-KLL	LOD1450
	FM=M1(KC)	LOD1460
	AA=CHORD*SJ(KL,KC)*WIDTH(KC)/FM	LOD1470
	CLT=CLT+CL(I)*AA	LOD1480
	CMT=CMT+CM(I)*AA	LOD1490
	CDT=CDT+CD(I)*AA	LOD1500
	CLW=CLW+CA(I)*AA	LOD1510
	CMWT=CMWT+AW(I)*AA	LOD1520
	CDW=CDW+CPSWL(I)*AA	LOD1530
	CLWW=CLWW+X(4,I)*AA	LOD1540
	CMWWT=CMWWT+X(7,I)*AA	LOD1550
	CDWW=CDWW+X(6,I)*AA	LOD1560
	MM=(NCW-NW3)*I	LOD1570
	IF(LL.EQ.MJW2(IU,NL)) NL=NL+1	LOD1580
140	CONTINUE	LOD1590
	CLT=CLT*PI/(2.*HALFSW)	LOD1600
	CMT=CMT*PI/(2.*HALFSW)	LOD1610
	CDT=CDT*PI/(2.*HALFSW)	LOD1620
	CDCL2=CDT/(CLT*CLT)	LOD1630
	CLW=CLW*PI/(2.*HALFSW)	LOD1640
	CMWT=CMWT*PI/(2.*HALFSW)	LOD1650
	CDW=CDW*PI/(2.*HALFSW)	LOD1660
	CLWW=CLWW*PI/(2.*HALFSW)	LOD1670
	CMWWT=CMWWT*PI/(2.*HALFSW)	LOD1680

	CDWW=CDWW*PI/(2.*HALFSW)	LOD1690
	IF (CLWW.LE.0.001) GO TO 150	LOD1700
	CDWL2=CDWW/(CLWW*CLWW)	LOD1710
	GO TO 160	LOD1720
150	CDWL2=0.	LOD1730
160	CONTINUE	LOD1740
	WRITE (6,340)	LOD1750
	K1=0	LOD1760
	JJ1=0	LOD1770
	DO 240 I=1,NCS	LOD1780
	IF (NW(2).EQ.0) GO TO 180	LOD1790
	II=I+NCS	LOD1800
	IF (NW(3).NE.0) GO TO 170	LOD1810
	CHORD=CH(I)+CH(II)	LOD1820
	GO TO 190	LOD1830
170	III=II+NCS	LOD1840
	CHORD=CH(I)+CH(II)+CH(III)	LOD1850
	GO TO 190	LOD1860
180	CHORD=CH(I)	LOD1870
190	CONTINUE	LOD1880
	DO 230 J=1,NCW	LOD1890
	JJ=JJ1+J	LOD1900
	KK=K1+J	LOD1910
	IF (NW(2).EQ.0) GO TO 210	LOD1920
	IF (J.LE.NW(1)) GO TO 210	LOD1930
	IF (J.GT.NW2) GO TO 200	LOD1940
	LL=LPAN1+NW(2)*(I-1)+J-NW(1)	LOD1950
	GO TO 220	LOD1960
200	LL=LPAN2+NW(3)*(I-1)+J-NW2	LOD1970
	GO TO 220	LOD1980
210	LL=JJ	LOD1990
220	CONTINUE	LOD2000
	XI=(XV(LL)-XLE(I))/CHORD	LOD2010
	ETA=YV(LL)/HALFB	LOD2020
	CPW=2.*GAM(2,LL)*ALPC	LOD2030
230	WRITE (6,350) KK,XI,ETA,CP(LL),CPW	LOD2040
	JJ1=(NCW-NW3)*I	LOD2050
	KI=K1+NCW	LOD2060
240	CONTINUE	LOD2070
	WRITE (6,360)	LOD2080
	DO 250 I=1,NCS	LOD2090
	YE=YLE(I)/HALFB	LOD2100
250	WRITE (6,370) YE,CL(I),CM(I),CT(I),CD(I),X(4,I),X(7,I),X(6,I)	LOD2110
	WRITE (6,380) CLT	LOD2120
	WRITE (6,390) CDT	LOD2130
	WRITE (6,400) CDCL2	LOD2140
	WRITE (6,410) CMT	LOD2150
	IF (IUSB.NE.1) GO TO 300	LOD2160
	IF (DFJ.LE.0.001) GO TO 300	LOD2170
	IF (ZJET.GT.0.01) GO TO 300	LOD2180

	SDFJ=SIN(DFJ)	LOD2190
	CDFJ=COS(DFJ)	LOD2200
	CLR=CMU*SIN(DFJ+ALP)	LOD2210
	CDR=CMU*(VMU-COS(DFJ+ALP))	LOD2220
	CF=COS(TDF)	LOD2230
	SF=SIN(TDF)	LOD2240
	IF (NNJ.EQ.1) CDR=-CMU*COS(DFJ+ALP)	LOD2250
	IJ=(NSJ+1)/2-1	LOD2260
	IF (ISYM.EQ.0) IJ=NSJ/2-1	LOD2270
	IF (NW(3).NE.0) GO TO 260	LOD2280
	IF (NW(2).EQ.0) GO TO 270	LOD2290
	IZ=NCS+(MJWI(2,NJP)-LPAN1-1)/NW(2)+1	LOD2300
	KJ=MJWI(2,NJP)	LOD2310
	NN=NW(2)	LOD2320
	GO TO 280	LOD2330
260	IZ=NCS*2+(MJWI(3,NJP)-LPAN2-1)/NW(3)+1	LOD2340
	KJ=MJWI(3,NJP)	LOD2350
	NN=NW(3)	LOD2360
	GO TO 280	LOD2370
270	IZ=LC(1)	LOD2380
	KJ=MJWI(1,NJP)	LOD2390
	NN=NW(1)	LOD2400
280	CONTINUE	LOD2410
	CM1=0.	LOD2420
	DO 290 I=1,IJ	LOD2430
	YDIF=YN(KJ,2)-YN(KJ,1)	LOD2440
	CM1=CM1+YDIF/WIDTH(NJW(NJP))*((XLE(IZ)+CH(IZ)*CF)*SDFJ-CH(IZ)*SF*CL	LOD2450
	ODFJ)	LOD2460
	KJ=KJ+NN	LOD2470
290	IZ=IZ+1	LOD2480
	CMR=-CM1*CMU/CREF	LOD2490
	IF (NNJ.NE.1) WRITE (6,420) CLR	LOD2500
	IF (NNJ.EQ.1) WRITE (6,430) CLR	LOD2510
	IF (NNJ.NE.1) WRITE (6,440) CDR	LOD2520
	IF (NNJ.EQ.1) WRITE (6,450) CDR	LOD2530
	IF (NNJ.NE.1) WRITE (6,460) CMR	LOD2540
	IF (NNJ.EQ.1) WRITE (6,470) CMR	LOD2550
300	CONTINUE	LOD2560
	IF (IUSB.EQ.1) GO TO 310	LOD2570
	WRITE (6,480) CLW	LOD2580
	WRITE (6,490) CDW	LOD2590
	WRITE (6,500) CMWT	LOD2600
310	CONTINUE	LOD2610
	WRITE (6,510) CLWW	LOD2620
	WRITE (6,520) CDWW	LOD2630
	WRITE (6,530) CMWWT	LOD2640
	WRITE (6,540) CDWL2	LOD2650
	RETURN	LOD2660
C		LOD2670

