

NASA TECHNICAL MEMORANDUM

NASA TM X-74006

NASA TM X-74006

PRELIMINARY STUDY OF TUG-GLIDER
FREIGHT SYSTEMS UTILIZING A BOEING 747 AS THE TUG

(NASA-TM-X-74006)	PRELIMINARY STUDY OF	N77-18118
TUG-GLIDER FREIGHT SYSTEMS UTILIZING A		
BOEING 747 AS THE TUG (NASA)	52 p HC A04/MF	
A01	CSCL 01C	Unclas
	G3/03	17194

by

Harry H. Heyson and Willard E. Foss, Jr.
Langley Research Center

February 1977

This informal documentation medium is used to provide accelerated or special release of technical information to selected users. The contents may not meet NASA formal editing and publication standards, may be revised, or may be incorporated in another publication.

NASA
National Aeronautics and
Space Administration
Langley Research Center
Hampton, Virginia 23665

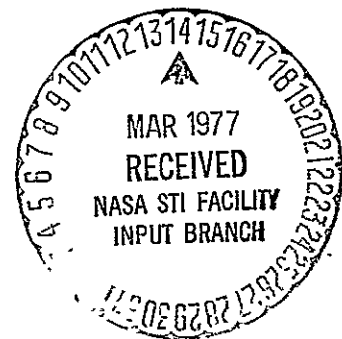

1. Report No TM X-74006	2. Government Accession No	3. Recipient's Catalog No	
4. Title and Subtitle PRELIMINARY STUDY OF TUG-GLIDER FREIGHT SYSTEMS UTILIZING A BOEING 747 AS THE TUG		5. Report Date February 2, 1977	6. Performing Organization Code 31.600
		8. Performing Organization Report No	
7. Author(s) Harry H. Heyson and Willard E. Foss, Jr.		10. Work Unit No	
9. Performing Organization Name and Address NASA Langley Research Center Hampton, Virginia 23665		11. Contract or Grant No	
		13. Type of Report and Period Covered Technical Memorandum	
12. Sponsoring Agency Name and Address National Aeronautics & Space Administration Washington, DC 20546		14. Sponsoring Agency Code	
15. Supplementary Notes			
16. Abstract Performance of the tug-glider systems is severely limited by ground run. In most cases studied, additional engines are necessary. Except at short ranges for which additional payload can be carried in the tow plane, the productivity of the basic aircraft is degraded by a reduction in cruise speed necessitated by the glider drag. Excessive aspect ratios do not improve system performance because of the increase in glider wing weight. Powered gliders using a tow plane only for takeoff and climb have the potential for a major reduction in fuel consumption. Uncertainty of restrictive regulatory action and the apparently increased airborne investment per unit productivity are obstacles to commercial development. Some military potential may exist, leading to increased commonality of the basic aircraft in both military and commercial use.			
17. Key Words (Suggested by Author(s)) AIRCRAFT DESIGN TESTING AND PERFORMANCE, GLIDERS, AIR FREIGHT, STATED AIRCRAFT		18. Distribution Statement UNCLASSIFIED-UNLIMITED	
19. Security Classif (of this report) Unclassified	20. Security Classif (of this page) Unclassified	21. No of Pages 51	22. Price* \$4.50

PRELIMINARY STUDY OF TUG-GLIDER FREIGHT SYSTEMS
UTILIZING A BOEING 747 AS THE TUG

By Harry H. Heyson and Willard E. Foss, Jr.

Langley Research Center

SUMMARY

Performance of the tug-glider systems is severely limited by ground run. In most cases studied, additional engines are necessary. Except at short ranges for which additional payload can be carried in the tow plane, the productivity of the basic aircraft is degraded by a reduction in cruise speed necessitated by the glider drag. Excessive aspect ratios do not improve system performance because of the increase in glider wing weight. Powered gliders using a tow plane only for takeoff and climb have the potential for a major reduction in fuel consumption. Uncertainty of restrictive regulatory action and the apparently increased airborne investment per unit productivity are obstacles to commercial development. Some military potential may exist, leading to increased commonality of the basic aircraft in both military and commercial use.

INTRODUCTION

During the second world war, extensive use was made of towed gliders for transporting men and material during assault operations. The towed glider possessed certain outstanding advantages as a wartime expediency; however, subsequent analyses of towed gliders for peacetime freight transport diverge widely on the overall system efficiency (refs. 1-3).

A recent paper (ref. 4) has indicated that the productivity of the C-130 transport could be increased significantly under certain conditions by using it as a tow plane for gliders. The present study attempts to ascertain whether or not the addition of a glider train to a modern jet freighter results in similar gains.

As a starting point, several gliders of high aerodynamic efficiency were designed to the point where reasonable estimates of weight and performance could be made. Next the takeoff performance of the combined tug-glider system was calculated to obtain feasible combinations of takeoff gross weights. Aerodynamic interference and tow-cable drag were examined to determine the best relative locations of the tug and glider in cruise. The tow cable drag and interference factors from this study were incorporated into a modified version of the Vehicle Integration Branch long-range cruise program to obtain the range-payload performance and energy efficiency of the combinations.

**ORIGINAL PAGE IS
OF POOR QUALITY**

Using the B-747 as a tow plane leads to severe restraints because of runway distance. In general, significant range-payload performance of the tug-glider system requires the addition of more engines. Since additional engines are needed, the possibility of adding these engines to the glider rather than the tow plane was considered. In this concept, the powered glider is towed to cruise altitude and then continues on its own. This system is compared with the standard B-747 and with the towed glider system.

The entire analysis has been conducted on the assumption that the towed system is to be operated in commercial service over relatively long ranges. Under such conditions, productivity and efficiency are of paramount concern. Operation in military service, particularly under combat conditions, shifts the primary emphasis to operational flexibility and greatly increases the potential of the system. While no complete analysis of military use was conducted in the present study, a few remarks on military application are included.

SYMBOLS

A	Wing aspect ratio, b^2/S	
b	Wing span	
BTU	British thermal unit (1 BTU = 1054.35 joules)	
C_D	Drag coefficient, (Drag)/ qS	
C_{D_i}	Induced drag coefficient, (Induced drag)/ qS	_____
C_L	Lift coefficient, (Lift)/ qS	
h	Altitude above mean sea level	
L/D	Lift-drag ratio, C_L/C_D	
mac	Mean aerodynamic chord	
M	Mach number	
q	Free-stream dynamic pressure	
S	Wing area	
TOGW	Takeoff gross weight	
V_∞	Free-stream velocity	
W	Aircraft weight	

α	Angle of attack of tow cable with respect to the free stream
ϵ	Average value of interference downwash angle over the wing of the affected aircraft
ϵ_0	Average value of the downwash angle over the wing of the aircraft causing interference
ΔC_{D_i}	Increment in induced drag coefficient caused by interference from a second aircraft

Subscripts:

G	Glider
T	Tug
T0	Takeoff

RESULTS AND DISCUSSION

High Efficiency Gliders

Configuration.- Two basic gliders were designed for this study. These gliders together with their lift-drag polars and lift-drag ratios, are illustrated in figures 1 and 2.

The first glider (fig. 1) had an aspect ratio of 25, a span of 118 m (387.3 ft), a maximum lift-drag ratio of 36.5, and a gross weight of 2.892 MN (650,044 lb) for a payload of 1.334 MN (300,000 lb). A smaller glider with half the payload and the same aspect ratio was also designed. The fuselage was somewhat larger in proportion to the wing, reducing the maximum lift-drag ratio, and the payload weight fraction was poorer (Table I) when compared to the larger glider. Consequently, the smaller glider was eliminated from further consideration.

A second glider of aspect ratio 14 was also designed (fig. 2). For this glider, the span was 88.4 m (290 ft), the maximum lift-drag ratio was 28, and the gross weight was 2.360 MN (530,451 lb) for the same payload of 1.334 MN (300,000 lb). Comparison of the weight statement (Table II) with the higher aspect-ratio glider shows that the major portion of the weight reduction is in the weight of the wing.

Design Considerations.- Both gliders use sailplane technology in that they achieve high lift-drag ratios by the use of aspect ratios which are large compared to current powered aircraft. However, there are also major differences from sailplane configurations. First, the fuselage is relatively larger than that of a sailplane in order to provide volume for the payload. The payload for this study was presumed to have a density of 160 kg/m³

(10 lb/ft³) and to be packaged in special containers. The use of a lighter cargo density or of standard 2.4 x 2.4 m (8 x 8 ft) containers would increase the fuselage volume with consequent effects on both weight and drag. Second, compared to typical sailplane wing loadings of 239 to 335 N/m² (5 to 7 lb/ft²), the present wing loadings are an order of magnitude greater: 5.17 kN/m² (108 lb/ft²) for an aspect ratio of 25, and 4.21 kN/m² (88 lb/ft²) for an aspect ratio of 14. The heavy wing loadings are necessary, not only to obtain aerodynamic compatibility with the B-747 tow plane, but also to achieve reasonable values of wing area, weight, and span. Indeed, it is largely because of the heavy wing loading that the structural weight fraction of these new gliders is so favorable compared to those of reference 4 (fig. 3).

Landing Considerations.- Since the only reduction in glider weight during flight is the minor amount of fuel consumed by the auxiliary power unit, the landing wing loadings will be as high (or higher) than those of current jet transports. Thus, a high-lift flap system similar to those in current use is required. Such systems create considerable drag, so that current practice is to use significant amounts of power on landing approach. In the absence of power, the glider must either use small flap deflections and land "hot", or must use an approach slope far steeper than the present 3-degree slope, thus complicating the present terminal air-traffic control system. Furthermore, the absence of engines precludes the possibility of "go-around" on a missed approach.

Admittedly, thousands of sailplane tows are made each year with a negligible accident rate and with little or no regulatory interference. The cargo gliders considered herein are extremely large and have landing speeds comparable to jet transports. The extent to which commercial operation of such gliders would be tolerated prior to regulatory action by FAA is problematical.

Excess Thrust

Takeoff.- Figure 4 (from ref. 4) shows the available excess thrust for the C-130 tug of that study as a function of takeoff ground roll. It will be observed that the C-130 was designed as an assault transport; thus, major design emphasis was on short-field operation at the expense of transport efficiency. Consequently, large amounts of excess thrust are available if the aircraft is allowed to operate from field lengths typical of commercial airports. It is this characteristic of the aircraft which leads to the increases in productivity demonstrated in reference 4. If constrained to operate out of its design field length, the C-130 would show little or no productivity improvement when using gliders.

Figure 5 presents the available excess thrust of the B-747 as a function of altitude and Mach number for two gross weights. This figure has been prepared on the basis of the clean configuration and cruise thrust ratings. At the heavier weight (fig. 5(a)), extrapolation of the $h = 0$ curve to takeoff speed indicates that the B-747 has no excess thrust at takeoff from its design

field length of 3.17 km (10,400 ft). Indeed, when the drag increase of the takeoff configuration is considered, it is clear that takeoff is only possible because of the increased 5-minute takeoff rating using water injection. On the other hand, at reduced gross weight (fig. 5(b)), there is a reasonable amount of excess thrust at takeoff. This thrust might be employed to take off towing a glider.

Cruise.- At cruise altitude, and at its cruise Mach number in excess of $M = 0.8$, figure 5 shows that the B-747 has little or no excess thrust. If it is to tow gliders, it is evident that this aircraft must operate at lower than normal altitudes and Mach numbers. The reduced cruise speed will produce an obvious penalty in trying to obtain increased productivity.

Productivity.- Figure 5 indicates that the B-747 airframe is almost perfectly matched to its engines, and that the total configuration is almost perfectly matched to available field lengths. It is because of this compatibility that the aircraft achieves its remarkable productivity and efficiency. Figure 6 shows the productivity of the C-130 (in terms of throughput), with and without a glider, as given by reference 4. A point representing the maximum cargo capability of the basic B-747 has been added for comparison. Because of the impressive performance of the B-747, as well as the inability to accept significant increases in field length, it is obvious that it is far more difficult to improve the productivity of the B-747 than the C-130 of reference 4.

Takeoff Considerations

Balanced Field Length.- Field length for transport aircraft is generally certificated as a balanced field length where, upon failure of the most critical engine, the aircraft can either continue takeoff over an obstacle or brake to a stop in equal distances. Several possible additional considerations should be included for gliders; the safe distance might depend upon which aircraft leaves the ground first, and it might require consideration of tow-cable failure. For commercial operation, regulatory agencies could impose restrictions which would seriously affect the required field length. For this reason, only the ground roll is considered herein. This ground roll is determined by a suitably modified form of the equation given in reference 5.

Aspect Ratio of 25.- Calculated ground runs for the B-747 with and without the high aspect-ratio glider are presented in figure 7. The calculated ground run of 2.68 km (8,800 ft) is approximately correct for the certificated 3.17 km (10,400 ft) runway length of the basic B-747. Therefore, this length will be used throughout the present paper as the maximum allowable field length.

It is clear from figure 7(a), that the basic B-747 can lift the glider from the runway only when its own gross weight is so low as to preclude the presence of cruise fuel. A major increase in available thrust is required.

ORIGINAL PAGE IS
OF POOR QUALITY

Consequently, similar calculations are presented in figure 7(b) for a B-747 with two additional engines. With the additional engines, the B-747 can have a takeoff gross weight of 3.11 MN (700,000 lb) and still take off while towing the glider.

Conceptually, the additional engines could be mounted from the fuselage sides in the manner of numerous executive transports. It is estimated that the engines and struts would add approximately five percent to the zero-lift drag of the aircraft. A more serious penalty is the weight increase involved in the installation of the engines, struts, fuel systems, and attachment-point reinforcements. This weight is estimated to total 198 kN (44,450 lb). These penalties would be present on alternate missions when the glider is not used; however, the additional thrust might yield some compensatory benefits by shortening field length or increasing the allowable takeoff gross weight.

Aspect Ratio of 14.- The lighter weight of the lower aspect-ratio glider leads to significantly better takeoff performance with four engines (fig. 8(a)). In this case, the gross weight of the B-747 may be as great as 2.447 MN (550,000 lb) while taking off with the glider. With six engines (fig. 8(b)), the maximum weight of the B-747 is virtually the same as it was with the high aspect ratio glider, 3.158 MN (710,000 lb).

Powered Gliders.- An alternative to installing additional engines on the tow plane is to install the extra engines on the glider. This approach eliminates the penalty on the basic aircraft when not towing the glider, and, simultaneously, it may provide adequate cruise power once the powered glider has reached cruise altitude. Thus, the tug need be used only during takeoff and climb, after which the glider can continue without assistance. The weight and drag penalties of the engines must now be applied to the glider, which, in addition, must have increased useful load capability to carry fuel. Scaling the gliders of figures 1 and 2 upward at constant wing loading results in the powered gliders shown in the following table:

A	25	14
b, m ft	132 433	100 329
S, m ² ft ²	697 7500	720 7750
TOGW, MN lb	3.614 812,500	3.048 685,170
Total fuel, Mg lb	49.90 110,000	51.26 113,000

As will be shown subsequently, these powered gliders have several interesting characteristics. Not the least of these is the takeoff performance which is shown in figure 9. Since the tug has a short mission involving only takeoff, climb, and return, it requires little fuel. Thus, the B-747 needs only a takeoff weight of about 2.224 MN (500,000 lb) at most. Under these conditions, figure 9 shows that the ground run is always less than that for the fully loaded B-747 operating without a glider.

Interference in Cruise

Tow-Cable Drag.- In addition to the thrust required to propel the glider, thrust must be provided to overcome the drag of the tow cable. Hoerner (ref. 6) gives the drag coefficient of a straight inclined cylinder as:

$$C_D = 1.1 \sin^3 \alpha + 0.02$$

where C_D is based on the product of length and diameter. This drag coefficient is used herein for the cable; however, its use is open to several objections. First, the cable is not straight but lies on a curve determined by the combined action of the aerodynamic forces and the cable tension. Thus, the cable length is actually longer than the straight-line distance between tug and glider. Second, and again because the cable is curved, the average drag coefficient of the cable, which depends on $\sin^3 \alpha$, will be greater than that for a straight cylinder. The actual drag values probably will be significantly greater than those used herein.

Figure 10 shows the equivalent flat-plate drag area of the cable per 2.54 cm (1 in) of diameter as a function of the glider position with respect to the tug for an in-line tow. The powerful effect of the $\sin^3 \alpha$ term is obvious, since for a constant drag coefficient, the drag contours would be concentric circles. It is obvious that the drag contours are rotationally symmetric about a stream-wise line through the attachment point.

Induced Interference.- The glider and the tug each induce a "downwash" at the other's location. Thus each aircraft will have the performance that would be obtained if it were climbing at this "downwash" angle (which may be negative). The interference can be calculated in nondimensional terms from the simple considerations in reference 7; the result being a ratio ϵ/ϵ_0 of the downwash at the affected aircraft to the mean downwash at the wing of the aircraft causing the interference. This leads to an additional induced drag on the glider of

$$\Delta C_{Di} = \frac{\epsilon}{\epsilon_{0T}} \left(\frac{C_L}{\pi A} \right)_T C_{LG}$$

and on the tug

$$\Delta C_{D_i} = \frac{\epsilon}{\epsilon_{0G}} \left(\frac{C_L}{\pi A} \right)_G C_{L_T}$$

In general, ϵ/ϵ_0 is negative in the second case, and the induced drag of the tug is slightly decreased. At the glider, ϵ/ϵ_0 may be large and positive or moderately negative depending on the relative positions of tug and glider.

Combined Effect of Cable and Interference.- The mutual interplay of cable drag and induced interference can be seen most clearly by means of a sample case. Figure 11 presents such calculations for a series of lateral displacements between the tug and the glider. In all cases, the best location for the glider is far behind the tug so as to minimize the downwash caused by the bound vortex. When towing the glider in line with the tug, the glider should also be separated vertically; the best cable angle being about 15 degrees. With any significant lateral displacement the preferred vertical position is with the two wings in the same plane. When the lateral displacement is sufficiently great, the lift-drag ratio of the glider is actually improved by the mutual interference despite the presence of the cable drag.

Figure 12 is a similar presentation of effective glider lift-drag ratio in a vertical cross-section five tug spans (about 300 m (1,000 ft)) behind the tug. Careful examination of this figure discloses, as might be expected, that the best efficiency is obtained when one glider wing-tip is centered in one of the rolled-up vortices of the B-747 tug. Because of the known vortex hazard behind the B-747, it was arbitrarily decided to maintain at least 30 m (100 ft) clearance from the plane of the tug wake. Maintaining this clearance would require tighter altitude control than is usually available.

Chosen Relative Position.- Figure 13 shows the effective lift-drag ratio as a function of lateral separation for the same sample case at the chosen minimum vertical separation. Regardless of cable diameter, the best lateral spacing is 1.4 tug spans.

The actual required cable diameter depends upon the worst, rather than the best, possible lift-drag ratio within the flight envelope. Determination of the worst case is beyond the scope of the present analysis. In the ensuing calculations, a 2.54 cm (1 in) diameter cable is assumed on the basis that some high tensile-strength material may be adequate.

In the actual climb-cruise calculations the present sample case was not used. The appropriate interference factors were used to adjust the induced drag at each point along the flight path, and a constant flat-plate drag increment was added to the glider. The cable drag for the chosen lateral spacing is shown in figure 14, and the interference factors at the glider and tug are shown in figure 15. Their overall effect on the glider and tug of the sample case is illustrated in figure 16.

The equations for both cable drag and induced interference are symmetric above and below the wake. If the glider is above the tug, the cable pulls upward on the tug, and an additional down-load is required from the tug tail to maintain equilibrium. A similar effect is encountered at the glider so that both aircraft would suffer a penalty in trim drag. The situation is reversed if the glider is low, and both aircraft then enjoy a reduction in trim drag. Thus, the glider should be positioned below the tug in cruise. The relative positions are shown in figure 17 where the two aircraft are drawn with the minor bank angles required to offset the side forces caused by cable tension.

The chosen location for cruise is not possible at takeoff. Positioning the two aircraft prior to takeoff with the full length of cable would cost 300 m (1,000 ft) of runway. Thus, the cable must be short at takeoff and then reeled out during climb. During takeoff, the glider generally lifts first (figs. 7-9) and will be above the tug. At some point during climb, it descends through the tug wake to the low cruise position. No assessment of possible vortex hazards during this maneuver has been made.

It should be emphasized that this analysis has been based solely upon aerodynamic efficiency. No examination has been made of effects on either longitudinal or lateral-directional stability. The dynamics of the coupled aircraft have not been considered, nor have possible pilot-induced oscillations been examined. Any of these items could prove to be significant restrictions in operational use.

Cruise Performance

Program.- Extensive modifications were made to the Vehicle Integration Branch Long-range cruise program in order to calculate the achievable range with the actual matching of tug and glider. Cable drag was accounted for by means of a constant increment in profile drag. A constant interference factor was used to calculate the induced drag due to mutual interference at each combination of tug and glider lift coefficients.

Reserves.- The calculation of required reserves generally requires calculation of a percentage increment of trip fuel, fuel burned in a missed approach and climb-out and hold at fixed altitude, and flight to an alternate airport. It is not clear that the identical requirements (particularly the missed approach) apply to a tug-glider combination. Consequently, a fixed reserve of 19.96 Mg (44,000 lb) of fuel was assumed for the B-747 either alone or as a tug. Half of this reserve was assumed for the powered gliders.

Tug-Glider Combinations with Aspect Ratio of 25.- It is evident from figure 5 that the excess thrust of the B-747 is inadequate to provide the same cruise speed with the glider as without the glider. It was found that the best range was obtained cruising at a Mach number of 0.6 in all cases.

Figure 18 presents the calculated range and fuel efficiency of the gliders with an aspect ratio of 25. With a six-engine B-747 tug, this glider can carry a 1.33 MN (300,000 lb) payload over about the same distance as the standard B-747 carries 1.11 MN (250,000 lb). The improvement in gross payload is achieved at a cost of about 15 percent in specific fuel consumption.

Although the maximum payload has been increased, the productivity of the tug-glider combination is less than that of the basic B-747 (fig. 19) because of the reduction in cruise speed. The loss in productivity may be countered by carrying an additional 445 kN (100,000 lb) of payload in the tug for a total payload of 1.78 MN (400,000 lb). The additional payload is obtained at the expense of available fuel so that the maximum range is reduced by one-third (fig. 18). Because of the increased payload, fuel efficiency is improved to the point where it is only slightly worse than that of the basic B-747.

Powered Glider with Aspect Ratio of 25.- The powered glider is towed to its absolute ceiling by a standard B-747 acting as the tug. From this point, the tug returns and the powered glider continues alone, achieving a range of about 4.44 Mm (2,400 n mi) with a payload of 1.33 MN (300,000 lb) (fig. 18). If available fuel is increased by 22.7 Mg (50,000 lb) at the expense of reducing payload to 1.11 MN (250,000 lb), a range of almost 7.41 Mm (4,000 n mi) is possible. This range is a significant increase over that attainable by the basic B-747 with the same payload; however, the most remarkable attribute of the powered glider is its fuel efficiency. The fuel required per ton-nautical mile by the powered glider, including the fuel used in the takeoff and climb of the B-747 tug, is only half that required by the basic B-747. This fuel saving is as great as that envisioned by the entire NASA Aircraft Energy Efficiency Program. Unfortunately, the fuel saving is accompanied by a substantial loss in productivity (fig. 19).

Powered Glider with Enroute Engine Failure.- Since the powered glider has so little power, the viability of the concept depends upon its ability to maintain flight in the event of engine failure. This case has been examined for an engine failure at mid-range (fig. 20). After engine failure, the aircraft must descend and decelerate. The thrust deficiency is sufficiently small that the required rate of sink never exceeds 2.54 m/s (500 ft/min). Finally, at $M = 0.3$ and 1.52 km (5,000 ft) altitude, the available thrust is sufficient to sustain level flight. Under these conditions, the aircraft can reach 3.63 Mm (1,958 n mi) before using reserve fuel. The original destination at 4.44 Mm (2,400 n mi) can be reached using the reserve fuel.

The engine-out mission cannot be accomplished if the aircraft must maintain the 1.1-percent climb gradient required by FAR part 25 requirements; thus, modification of this regulation would be required prior to development. Furthermore, the low engine-out altitude would be a severe restriction for overland flight.

Gliders with Aspect Ratio of 14.- Figure 21 presents range and fuel efficiency for the lower aspect-ratio gliders, both with a tug and as powered gliders. The decrease in structural weight of the gliders compensates for the lower lift-

drag ratio since range and fuel efficiency are similar to those of figure 18. Maximum range is actually slightly increased because of the greater amount of fuel carried by the tug.

One notable difference from the case of the high aspect-ratio glider is that the four-engine tug can take off with the low aspect-ratio glider (fig. 8). In this case, the tug has a relatively light gross weight, carries only a modest amount of fuel, and, consequently, has a relatively short range.

Optimum Aspect Ratio.- Comparison of figures 18 and 21 shows that, if anything, performance of the tug-glider combinations was improved by reducing the aspect ratio from 25 to 14. These two cases are insufficient to determine the best aspect ratio for the glider; however, an unpublished parametric study by Allen H. Whitehead and Jeffrey A. Yetter of the Langley Research Center suggests that the best aspect ratio may be on the order of 7 (about the same as the B-747 tug).

Staged Aircraft

The remarkable fuel efficiency of the powered gliders results from several factors. First, the powered glider has high aerodynamic efficiency because of its large aspect ratio. Second, the engines are the size required to barely maintain flight with no constraints imposed by takeoff field length or initial rate of climb. Finally, some portion of the gain is achieved by transferring part of the engine weight and required fuel to the tug which operates only in the initial phase of the flight. In effect, the powered-glider system is the aircraft equivalent of the staged rocket system used for orbiting large space payloads. The concept as applied to aircraft is not new. The same scheme was pioneered by the English Short Mayo-Mercury composite aircraft for transatlantic mail service in 1938.

The magnitude of the staging effect was examined by reconfiguring the powered gliders to four-engine aircraft. The gross weight was held constant while adding the weight and drag of the additional two engines. It was found that takeoff was not a restriction because the aircraft had about the same thrust-weight ratio as the B-747 and, in addition, the new aircraft had improved low-speed performance because of the higher aspect ratios.

The first effect noted was that the useful load decreased by over 245 KN (55,000 lb) compared to the powered gliders. The new aircraft had to carry not only the weight of the additional engines and fuel system, but also all of the fuel required for takeoff and initial climb. In addition, fuel reserves must be greatly increased. Because of the increase in available thrust, the best cruise speed increased slightly to $M = 0.65$. At 1.11 MN (250,000 lb) payload, the maximum range for either aspect ratio decreased to about 2.78 Mm (1,500 n mi) from the almost 7.41 Mm (4,000 n mi) maximum range of the powered gliders (fig. 18 and 21) with the same payload.

Fuel efficiency for the four-engine aircraft was found to be midway between the fuel efficiencies for the powered gliders and the basic B-747. Thus, about half the gain in fuel efficiency appears due to the improved aerodynamic efficiency related to the large aspect ratios of the gliders. The other half of the gain in efficiency, as well as a major increase in range capability, is due to staging.

Multiple Tow-Planes

The concept of staging was pursued further by brief examination of a very large glider of aspect ratio 14. The glider had a gross weight of 4.45 MN (1,000,000 lb), a payload of 2.52 MN (565,600 lb), and a span of 121.3 m (398 ft). This glider was presumed to use two standard B-747 aircraft as tugs for takeoff and initial climb to cruise altitude. Upon reaching cruise altitude, one tug (booster tug) would be released to return. The remaining tug (sustainer tug) would continue on to its destination towing the glider.

In consideration of typical runway widths and the size of the aircraft involved, placement of all three aircraft on the runway would be difficult. However, if the placement problem is ignored and the ground run is calculated as before, the results shown in figure 22 are obtained. If the booster tug has a takeoff gross weight of 1.78 MN (400,000 lb), which allows about 27.2 Mg (60,000 lb) of total fuel on board, the sustainer tug may have a takeoff gross weight of 2.67 MN (600,000 lb) which allows 99.3 Mg (219,000 lb) of fuel to be burned.

The large drag of the glider and the use of a single tug results in a reduced cruise speed of $M = 0.5$. At this speed, a range of almost 3.33 Mm (1,800 n mi) may be achieved (fig. 23). Because of the enormous payload, productivity (fig. 19) is increased over a single B-747. Fuel efficiency is improved by about 5 percent over the basic B-747 (figs. 21 and 23).

Economic Considerations

No complete economic analysis of the glider systems in commercial use is possible. Crew costs are a major factor in determining direct operating cost and this cost is determined, not only by certification requirements on minimum crew, but even more on the result of union-management negotiations. The outcome of such negotiations is not predictable; however, the tug-glider configurations will require more total crew members than a standard B-747. Long-range flights at low speed in the powered gliders may require multiple crews.

Initial airborne investment has been examined briefly using the method of reference 8 together with a crude estimate of the effect of quantity on price. In this regard, it must be noted that the B-747 has been in production for over a decade. The quantities already built have a favorable effect on price compared to the price for smaller quantities of a new glider.

Table III presents airborne investment relative to the standard B-747. It was assumed that the number of gliders was 20 percent of the total number of B-747 aircraft. Since the gliders are presumed to be of lower technology than the B-747, the lowest cost (turboprop technology) equation of reference 8 was used. Since the tug is only needed briefly by the powered gliders, these systems were charged for only one-fifth the cost of a tug.

Although Table III shows that several of the configurations listed have less investment cost per unit payload than the B-747, only the lower aspect ratio powered glider achieves a lower investment cost per unit of productivity. This system also results in a reduction of fuel cost which is attractive in itself. The real question is whether or not these savings could compensate for possible increases in maintenance and crew costs.

Regulatory Aspects

Current operation of sailplanes and gliders is remarkably free of regulatory restraint. To a major extent, this freedom results from the low accident rate of current designs, all of which are light and have very low wing loadings. The appearance of large, heavily loaded, freight gliders in commercial service could result in a far less permissive regulatory atmosphere. This situation already exists for powered aircraft where the certification of light planes is far simpler and easier than the certification of a commercial transport.

Numerous potential regulatory problems have been mentioned previously in this paper. These include possible redefinition of balanced field length, landing speeds, fuel reserves, and the need of waivers from current engine-out climb gradients for the powered gliders. Another difficult regulatory problem is that of noise. The initial climb gradients of the systems considered herein are marginal. The tug-glider systems do not appear capable of the rapid climb and engine-cutback maneuvers used by conventional transports to meet the noise restrictions imposed by FAR-36 regulations.

While there may be satisfactory answers to the regulatory problems, it is clear that they are a major obstacle to commercial development. The lack of definite, assured, requirements creates an atmosphere in which it is unlikely that an aircraft manufacturer would risk his capital to develop a commercial glider system.

Military Use

Historically, glider trains have seen major use only during wartime. Under such conditions gliders have led to increased flexibility. During the second world war, Great Britain found itself with an excess of obsolete bombers and inadequate airborne transport capability. Development of the Horsa and Hamilcar gliders allowed the obsolete bombers to be used in a transport capacity despite their inadequate internal volume. The United States used

C-47 transports to tow gliders, thereby circumventing the inadequate large-item loading capability of the basic transport aircraft.

At present, the B-747 glider combination does offer some military advantage. The M-60 tank presently can only be carried in the limited number of C-5A aircraft. Redesign of the B-747 to load and contain the M-60 is not only an expensive development but also penalizes weight and performance. On the other hand, the glider could be configured for this unique payload. In such a case, the penalties would only appear when this peculiar application was necessary. Furthermore, the same basic aircraft could be used by both military and commercial users. This commonality would increase the total quantity ordered with a decrease in cost to all users.

CONCLUSIONS

This study of tug-glider combinations using the Boeing 747 as a tow plane indicates that:

1. Performance of the tug-glider systems is severely limited by takeoff ground run. Additional engines would be required by most of the configurations studied.

2. Productivity of the basic B-747 is generally degraded by the reduction in cruise speed which results from towing a large glider, except at short ranges for which additional payload can be carried within the B-747.

3. Extreme glider aspect ratio does not improve the performance of the system because of the consequent increase in glider wing weight. An aspect ratio of 14 was as good as or better than an aspect ratio of 25. The best glider aspect ratio may be even lower.

4. Powered gliders with a tug to assist takeoff and climb to cruise altitude offer the potential of reducing fuel consumption by as much as 50 percent.

5. Federal Air Regulations pertaining to gliders could become much more severe for large, heavily loaded gliders. Uncertainty with respect to regulatory action is a major obstacle to commercial development.

6. Most of the configurations studied would require increased investment per unit of productivity.

7. The glider could be designed to carry specific military items which cannot be loaded into the basic aircraft. Such military use could increase the total production of the tug with consequent cost reductions for both military and commercial users.

REFERENCES

1. Klemm, Alexander; and Walling, Walter C.: Aerodynamic Performance of the Towed Glider. *Journal Aero. Sci.*, vol. 10, no. 6, June 1943. pp 185-196.
2. Nicks, Oran W.: *The Science of Low-Speed Flight. Motorless Flight Research*, 1972. (Webber, James L., ed.), NASA CR-2315, Nov. 1973. pp 78-85.
3. Ogden, Albert S.: Practical Considerations on the Use of Cargo Gliders. *Aero Digest*, vol. 41, no. 4, October 1942. pp 139-142.
4. Bonner, Tom F., Jr.; Snow, Daniel B.; Smith, Paul M.; and Quartero, Carlo B.: *A Study of Cargo Transporting Capability Utilizing Towed Gliders*. NASA LWP-1102, April 1973.
5. Perkins, Courtland D.; and Hage, Robert E.: *Airplane Performance Stability and Control*. John Wiley and Sons, New York, 1949. pp 194-197.
6. Hoerner, Sighard F.: *Fluid-Dynamic Drag*. Published by the Author, Brick Town, New Jersey, 1965. p 3-11.
7. Silverstein, Abe; Katzoff, S.; and Bullivant, W. Kenneth: *Downwash and Wake Behind Plain and Flapped Airfoils*. NACA Report 651, 1939.
8. Anderson, Joseph L.: *A Parametric Determination of Transport Aircraft Price*. Society of Allied Weight Engineers, Paper No. 1071, May 1975.

TABLE I

WEIGHT STATEMENT FOR GLIDERS WITH ASPECT RATIO OF 25

	1.334 MN (300,000 lb) PAYLOAD		0.667 MN (150,000 lb) PAYLOAD	
	kN	lb	kN	lb
WING	1019.07	229,097	511.55	115,000
HORIZONTAL TAIL	18.00	4,047	7.87	1,769
VERTICAL TAIL	13.55	3,046	5.90	1,327
FUSELAGE	212.80	47,840	138.78	31,200
LANDING GEAR	106.76	24,000	53.38	12,000
TOTAL STRUCTURE	1370.18	308,030	717.48	161,296
SURFACE CONTROLS	32.47	7,300	16.23	3,650
AUX. POWER UNIT	2.10	472	2.10	472
FUEL SYSTEM (APU)	7.53	1,692	7.53	1,692
INSTRUMENTS	3.44	773	3.44	773
HYDRAULICS	3.08	693	3.08	693
ELECTRICAL	9.34	2,100	9.34	2,100
AVIONICS	9.05	2,034	9.05	2,034
CARGO TIE-DOWNS	20.02	4,500	10.01	2,250
TOTAL SYSTEMS AND EQUIPMENT	87.03	19,564	60.78	13,664
EMPTY WEIGHT	1457.21	327,594	778.26	174,960
CREW (2 MAN)	2.00	450	2.00	450
OPERATING WEIGHT, EMPTY	1459.21	328,044	780.26	175,410
GROSS CARGO	1334.47	300,000	667.23	150,000
ZERO FUEL WEIGHT	2793.68	628,044	1447.49	325,410
APU FUEL (10 HRS)	97.86	22,000	97.86	22,000
TAKEOFF GROSS WEIGHT	2891.54	650,044	1545.35	347,410

TABLE II

WEIGHT STATEMENT FOR GLIDER WITH ASPECT RATIO OF 14

	kN	lb
WING	495.84	111,469
HORIZONTAL TAIL	24.26	5,453
VERTICAL TAIL	10.12	2,275
FUSELAGE	212.80	47,840
LANDING GEAR	95.19	21,400
TOTAL STRUCTURE	838.21	188,437
SURFACE CONTROLS	32.47	7,300
AUX. POWER UNIT	2.10	472
FUEL SYSTEM (APU)	7.53	1,692
INSTRUMENTS	3.44	773
HYDRAULICS	3.08	693
ELECTRICAL	9.34	2,100
AVIONICS	9.05	2,034
CARGO TIE-DOWNS	20.02	4,500
TOTAL SYSTEMS AND EQUIPMENT	87.03	19,564
EMPTY WEIGHT	925.24	208,001
CREW (2 MAN)	2.00	450
OPERATING WEIGHT, EMPTY	927.24	208,451
GROSS CARGO	1334.47	300,000
ZERO FUEL WEIGHT	2261.71	508,451
APU FUEL (10 HR)	97.86	22,000
TAKEOFF GROSS WEIGHT	2359.57	530,451

TABLE III

AIRBORNE INVESTMENT RELATIVE TO B-747

CONFIGURATION	PER UNIT PAYLOAD			PER UNIT PRODUCTIVITY		
	1.11 250	1.33 300	1.78 400	1.11 250	1.33 300	1.78 400
PAYLOAD, MN x 10 ⁻³ , lb						
BASIC B-747	1.00			1.00		
6-ENGINE B-747 + A = 25 GLIDER		1.40	1.05		1.87	1.41
4-ENGINE B-747 + A = 14 GLIDER		1.15	0.87		1.55	1.16
6-ENGINE B-747 + A = 14 GLIDER		1.29	0.97		1.73	1.30
A = 25 POWERED GLIDER	0.92	0.77		1.24	1.03	
A = 14 POWERED GLIDER	0.81	0.67		1.08	0.90	

ORIGINAL PAGE IS
OF POOR QUALITY

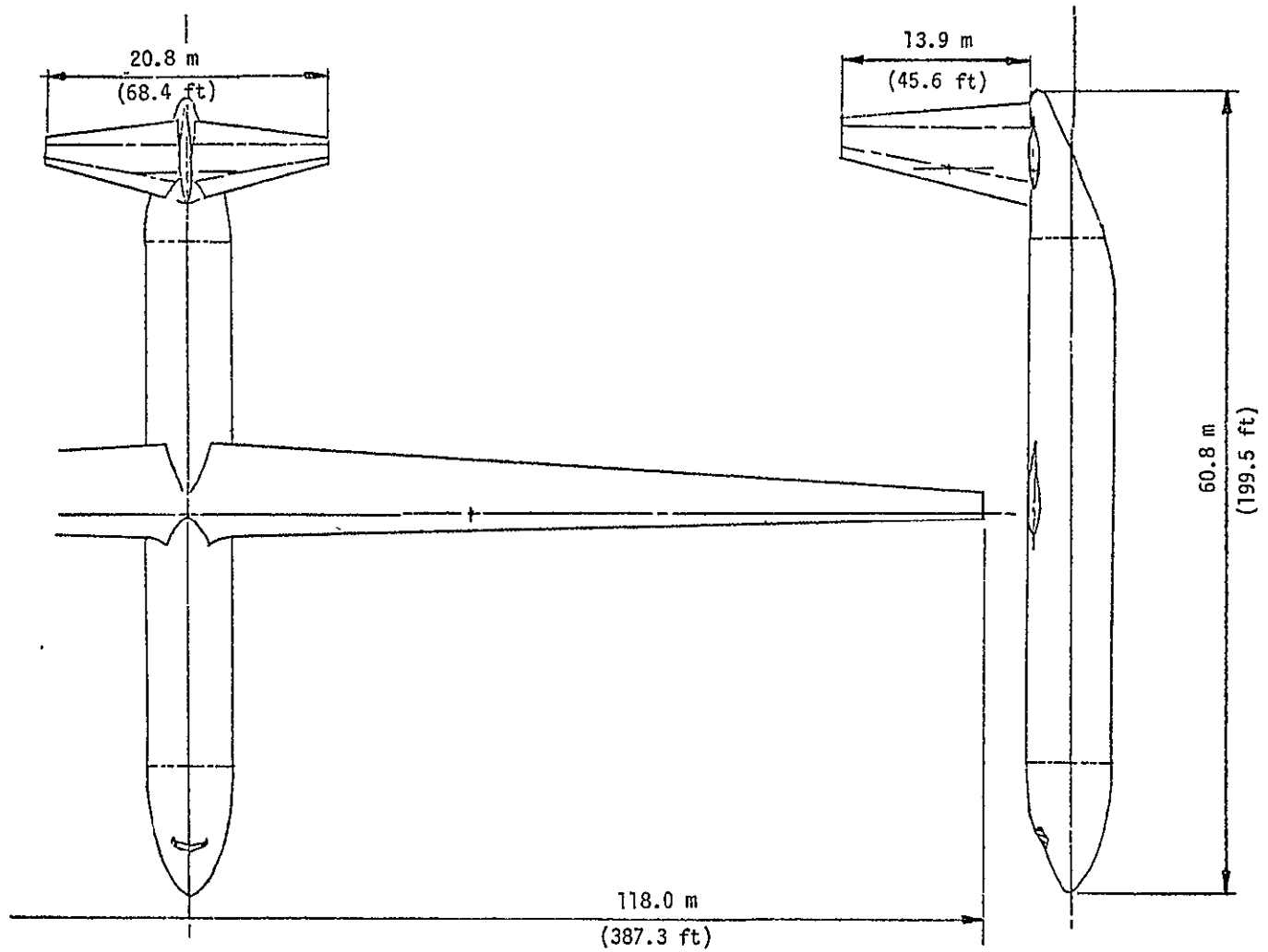

(a) General arrangement

Figure 1. - Cargo glider with aspect ratio of 25.
Payload = 1.334 MN (300 000 lb)
TOGW_G = 2.892 MN (650 044 lb)

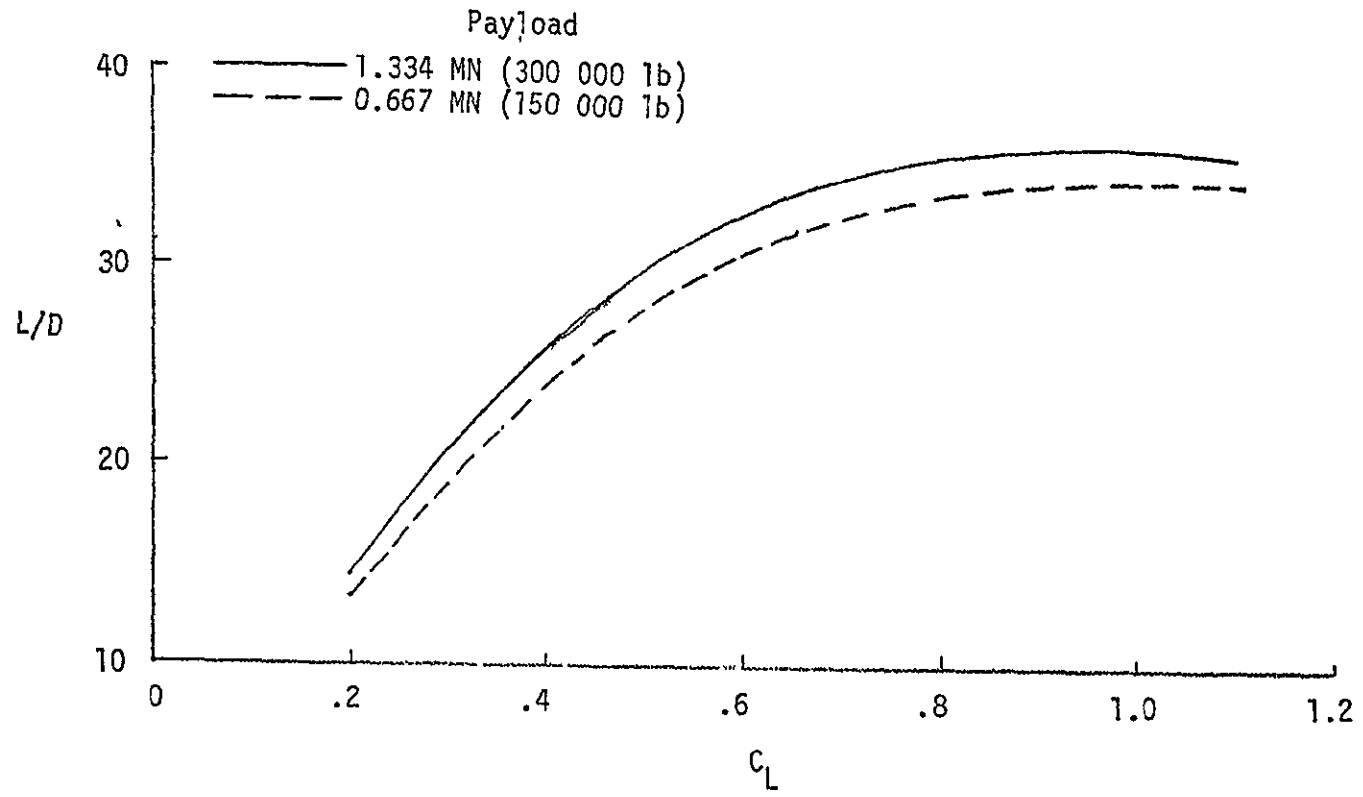

(b) Lift-drag ratios.

Figure 1. - Continued.

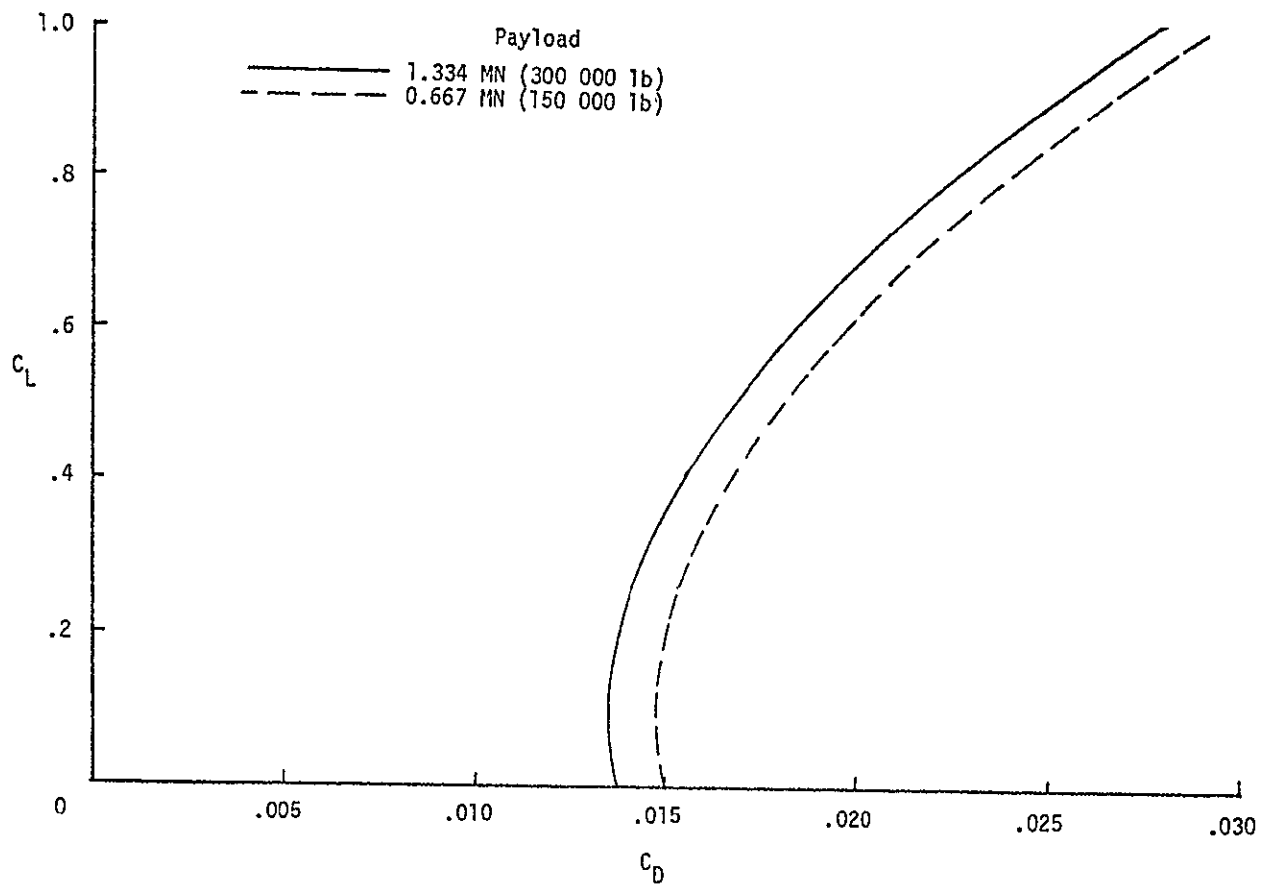

(c) Lift-drag polars

Figure 1. - Concluded.

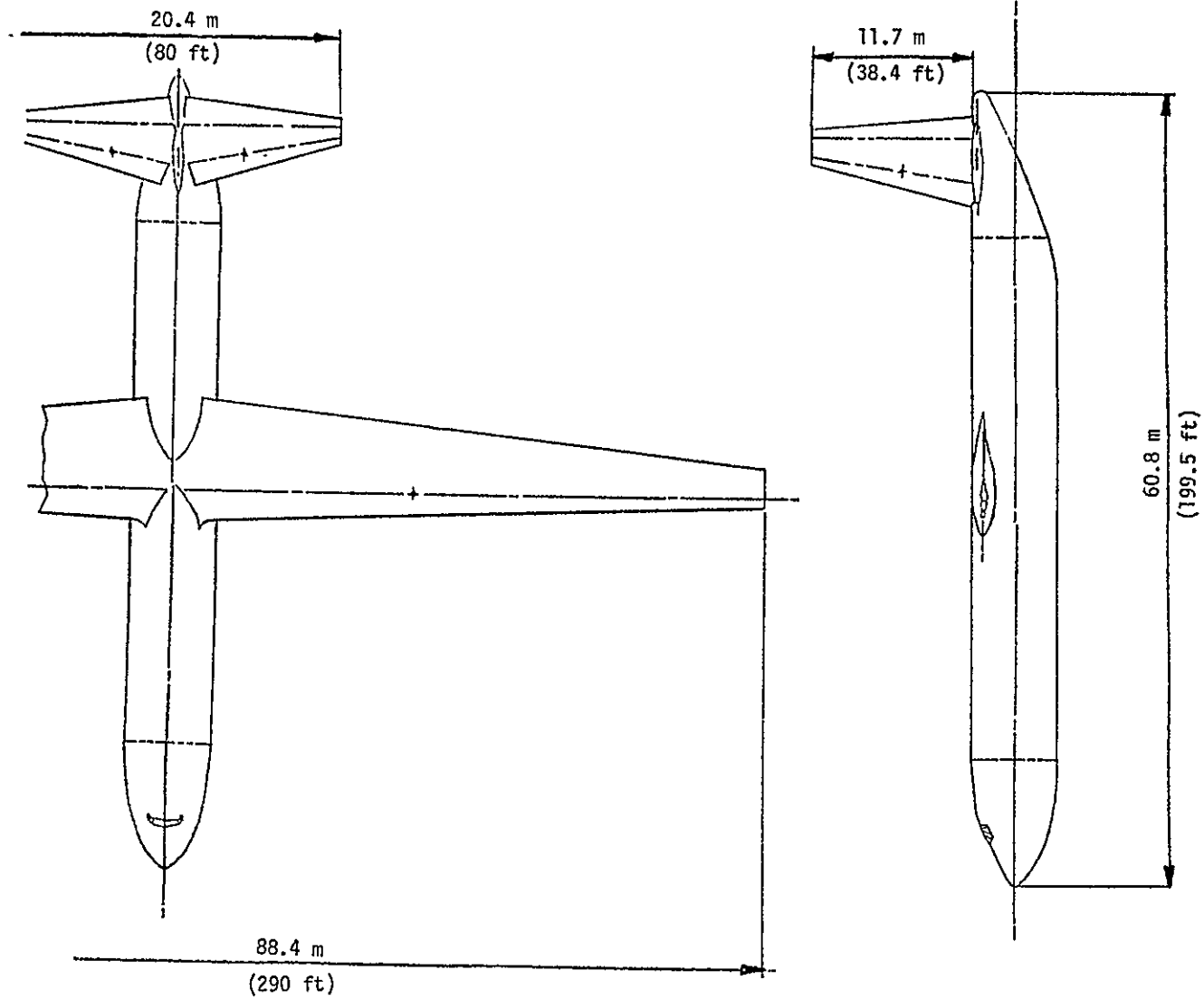

(a) General arrangement

Figure 2. - Cargo glider with aspect ratio of 14. Payload = 1.334 MN (300 000 lb),
 $TOGW_G = 2.360$ MN (530 450 lb)

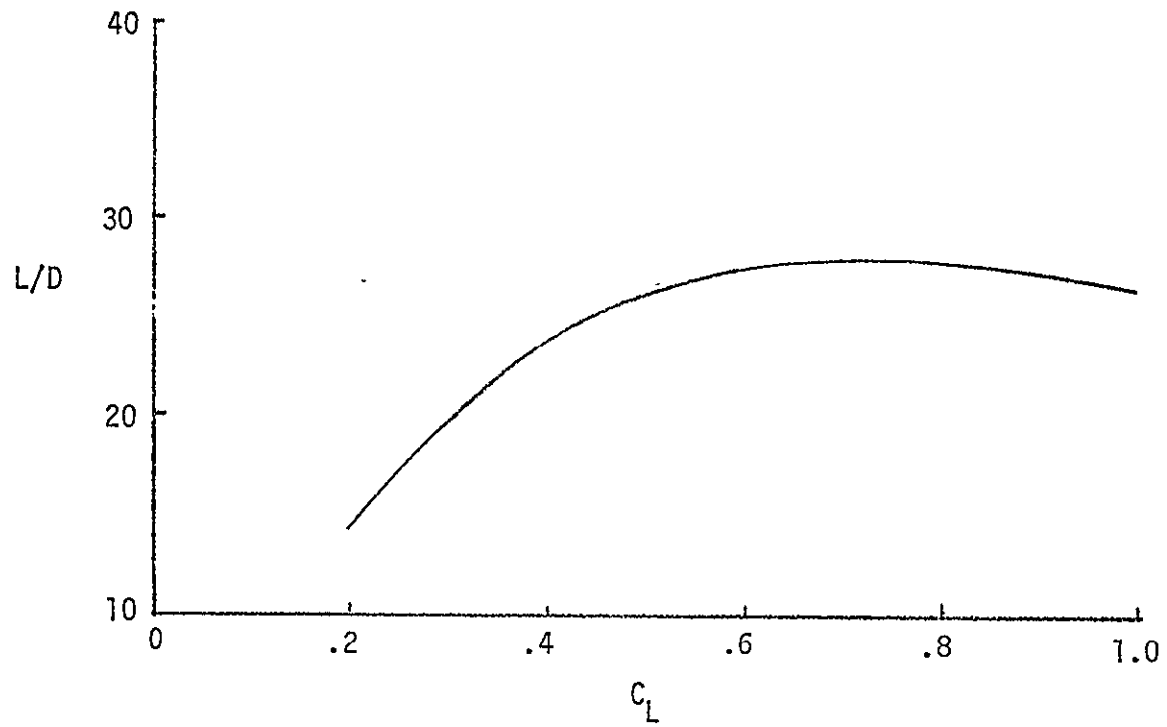

(b) Lift-drag ratio.

Figure 2. - Continued.

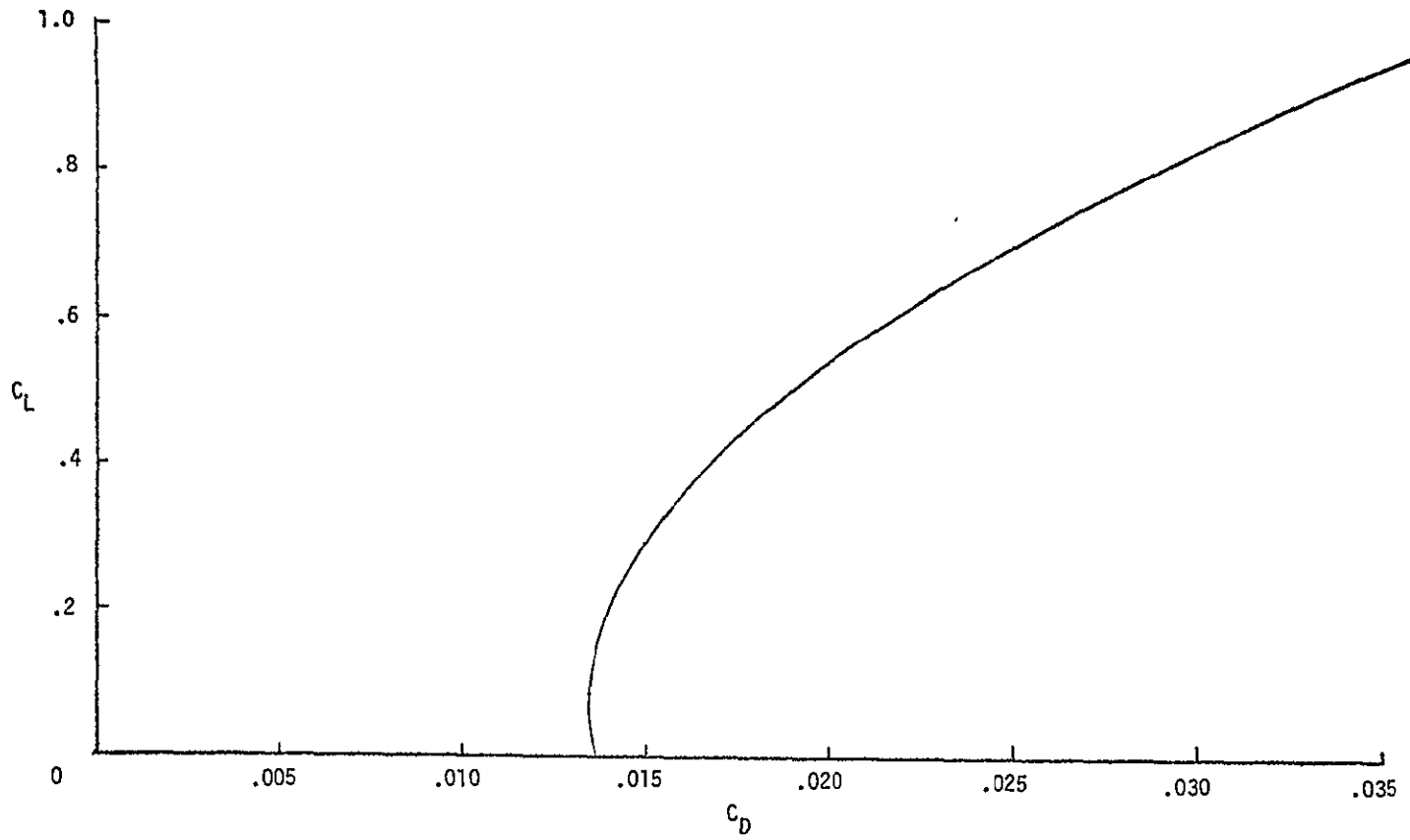

(c) Lift-drag polar

Figure 2. - Concluded.

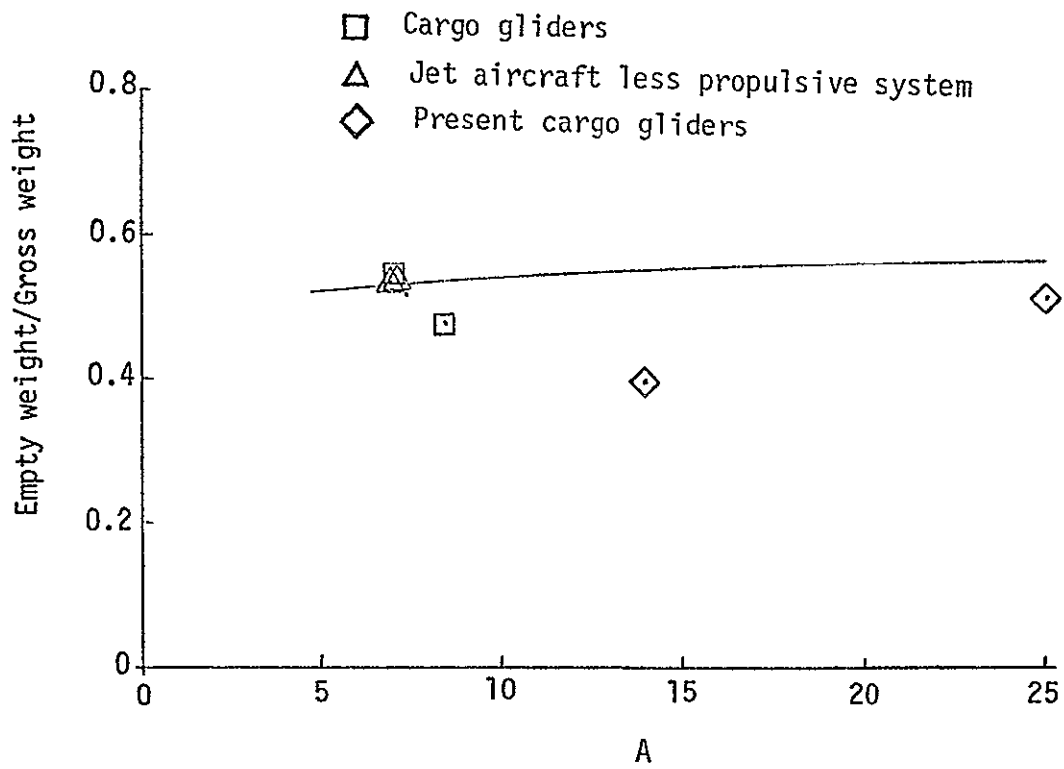

Figure 3. - Correlation of empty weight fraction of various aircraft (after reference 4).

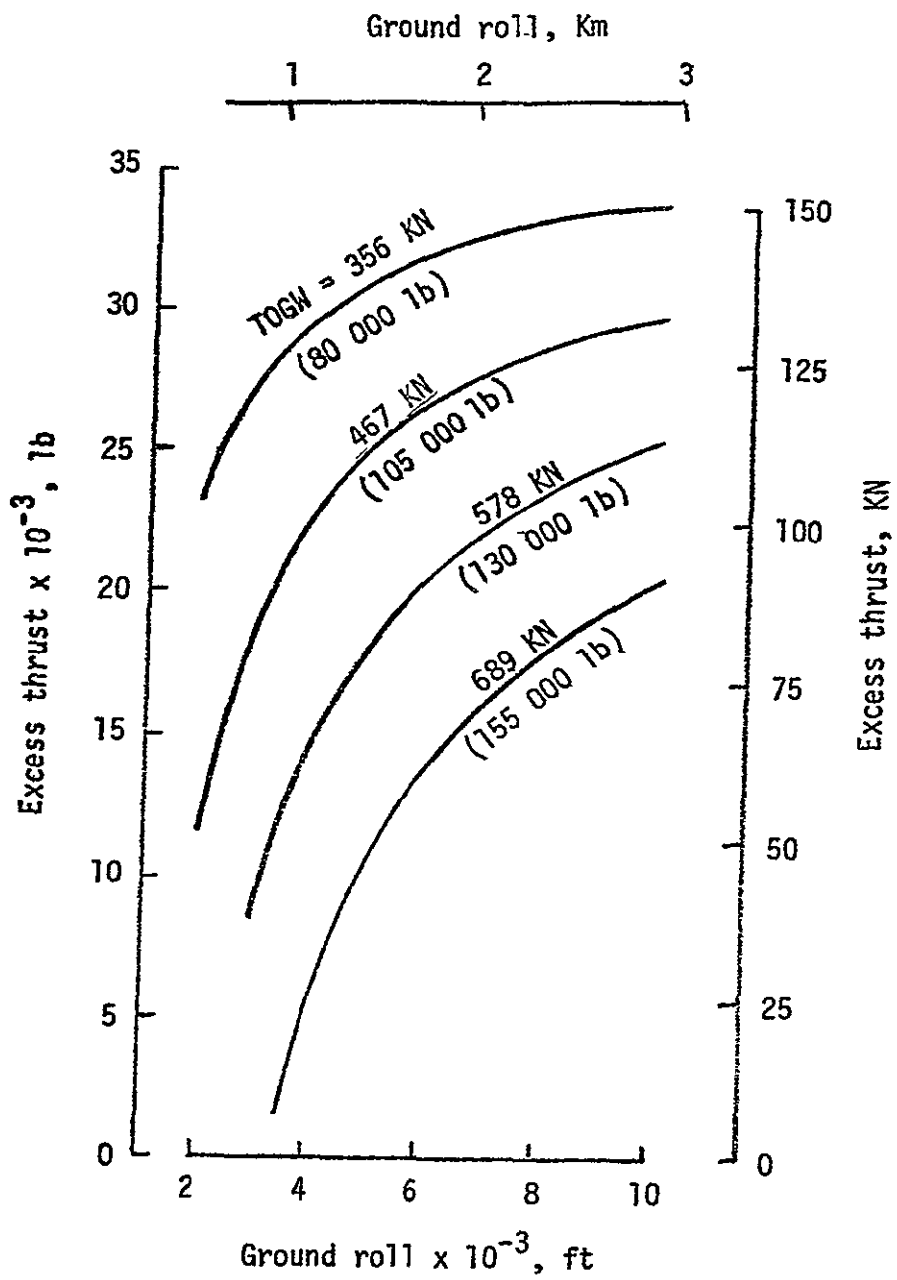
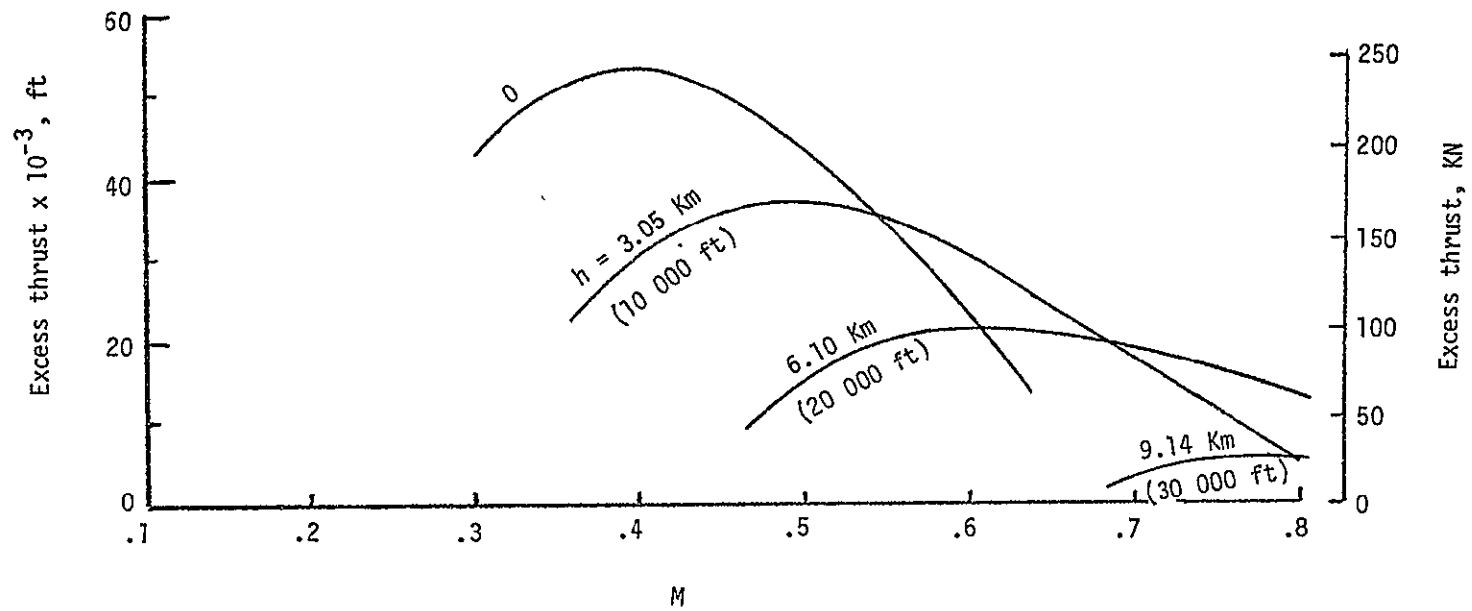
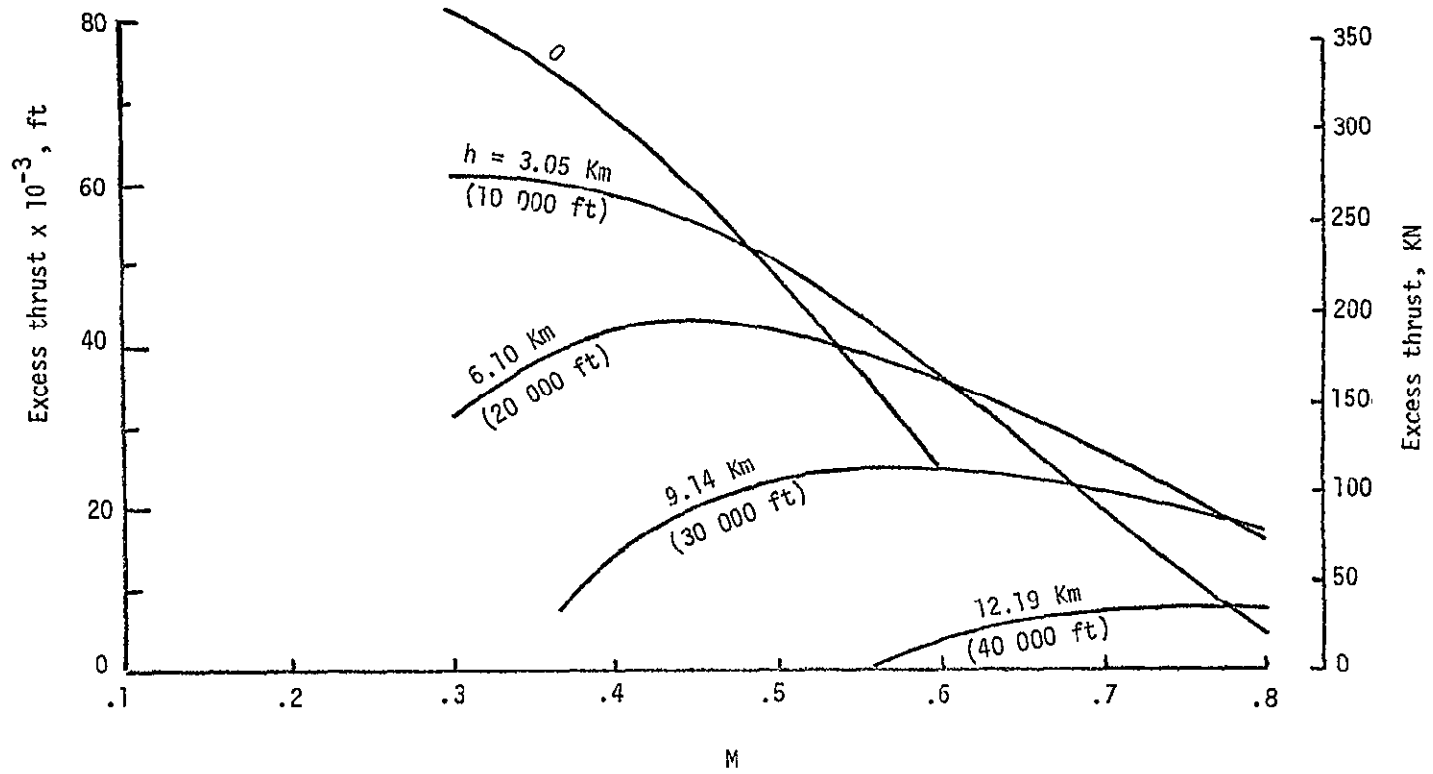

Figure 4. - Excess thrust available at takeoff for the C-130 aircraft (from reference 4).



(a) Gross weight = 3.26 MN (733 000 lb)

Figure 5. - Excess thrust of B-747 (JT9D-7F engines) in the clean configuration.



(b) Gross weight = 1.78 MN (400 000 lb)

Figure 5. - Concluded.

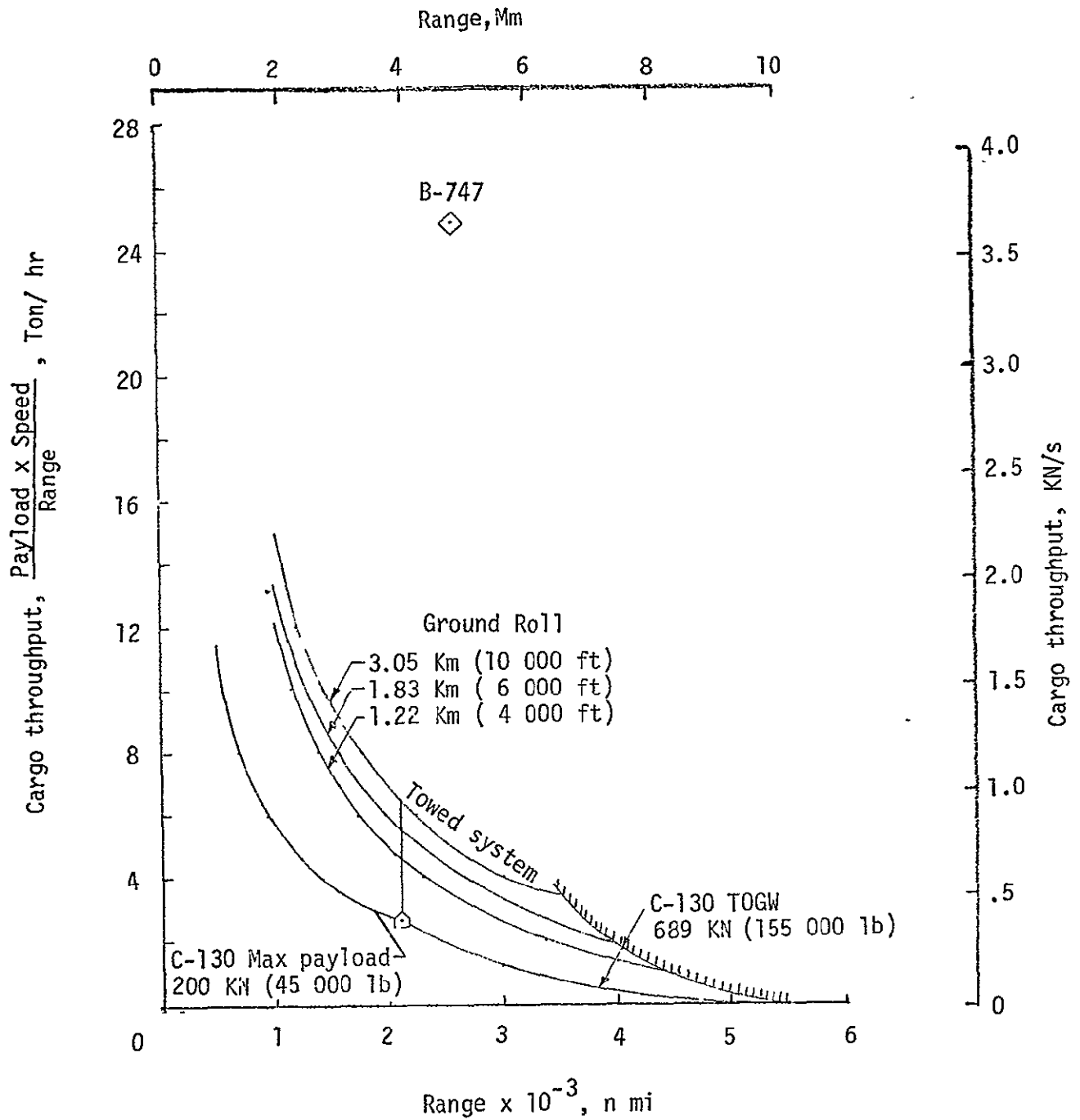
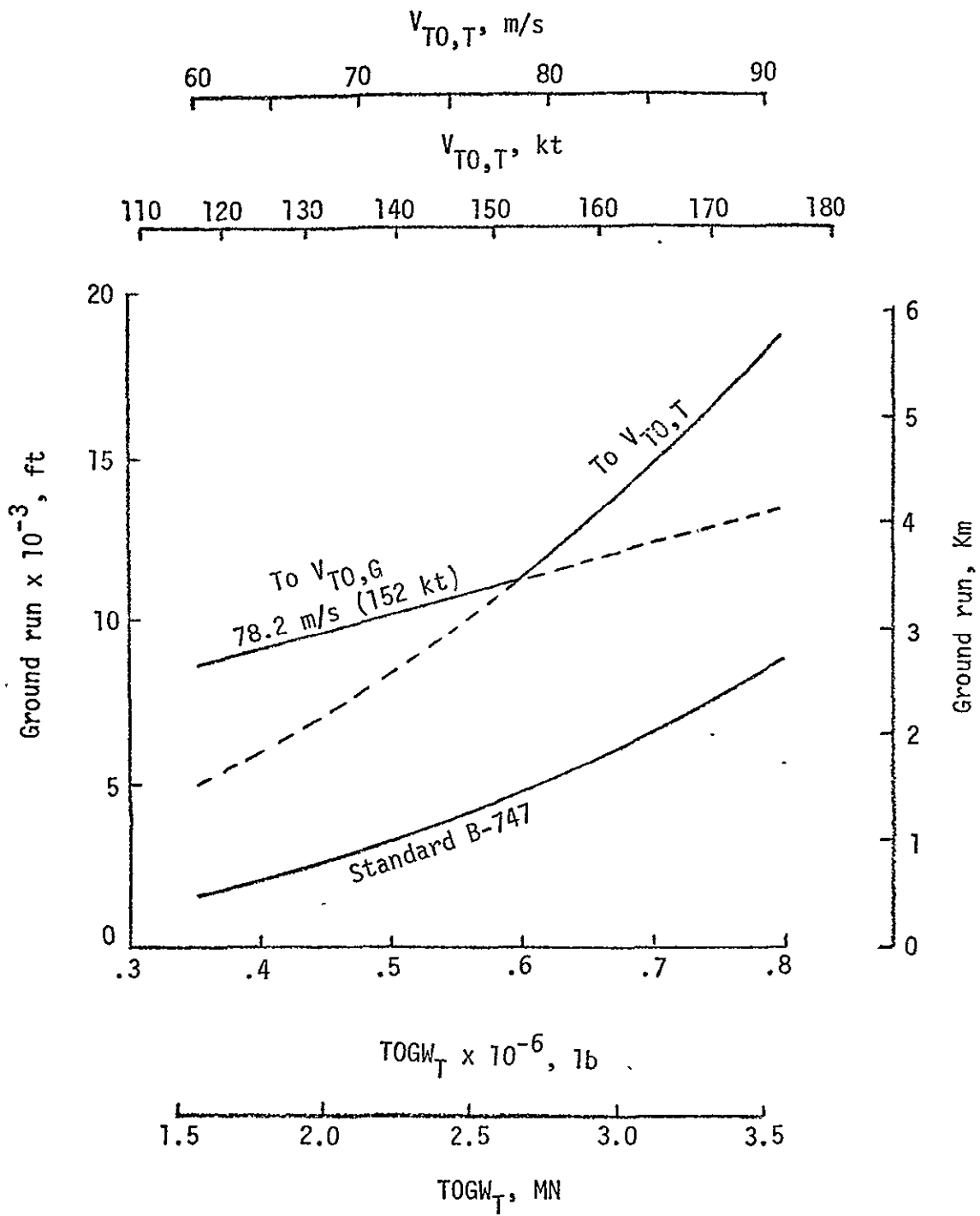
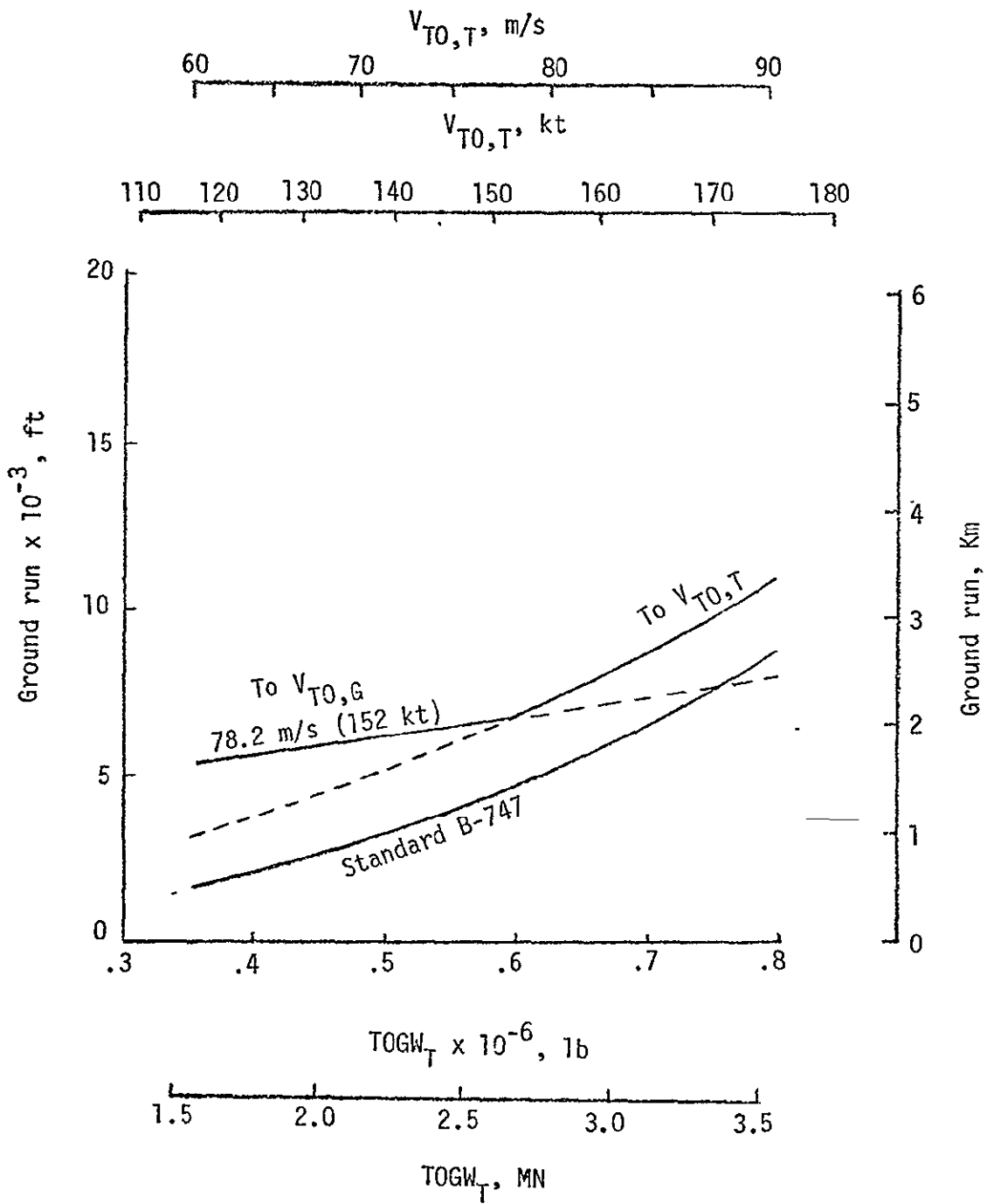

Figure 6. - Cargo system throughput for a single glider towed by a C-130 at an altitude of 4.57 Km (15 000 ft).
(After reference 4)



(a) 4 engines

Figure 7. - Ground run required by A = 25 glider with B-747 tug.
 $TOGW_G = 2.892$ MN (650 044 lb)



(b) 6 engines

Figure 7. - Concluded.

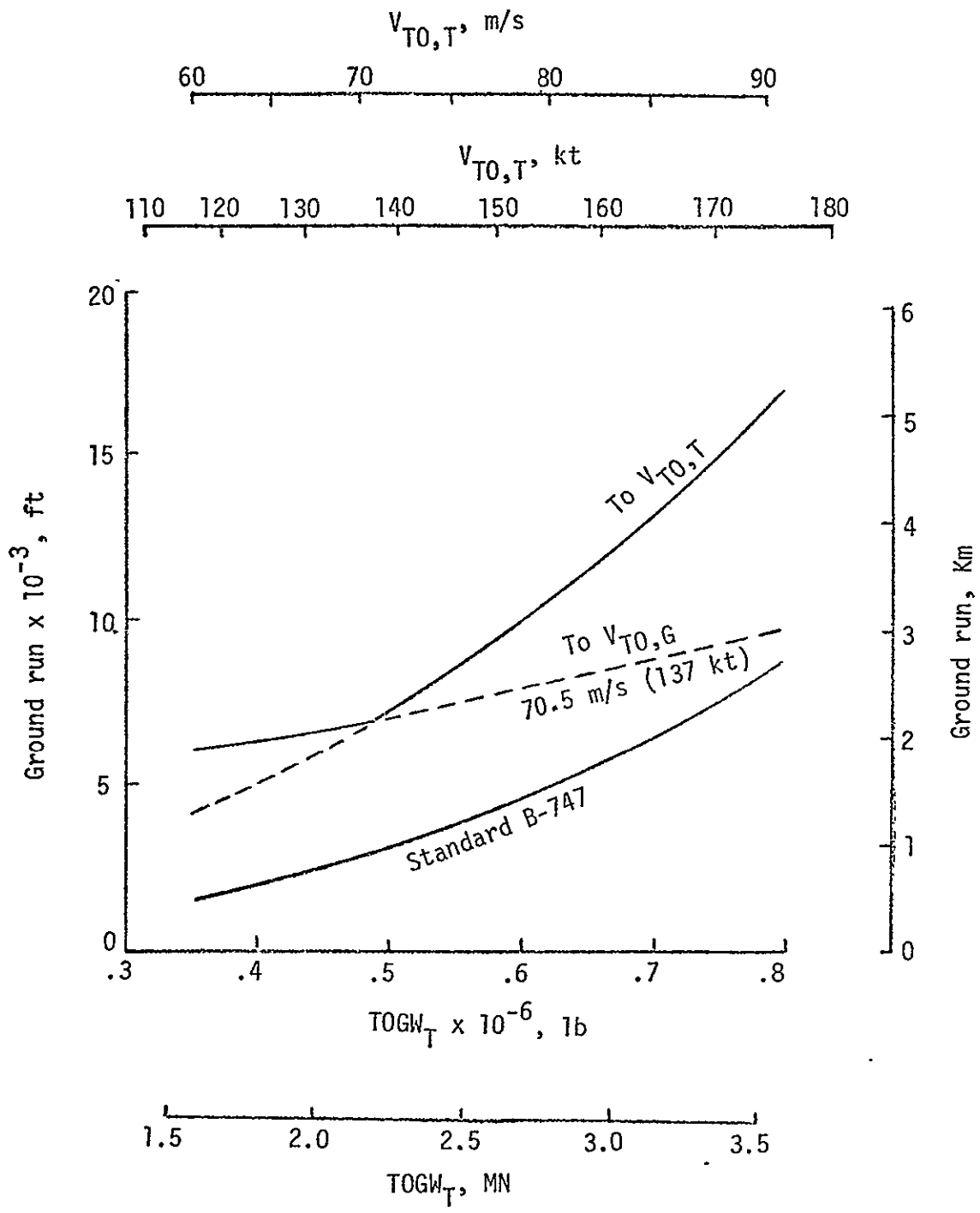

(a) 4 engines

Figure 8. - Ground run for A = 14 glider with B-747 tug.
 $TOGW_G = 2.360$ MN (530 450 lb)

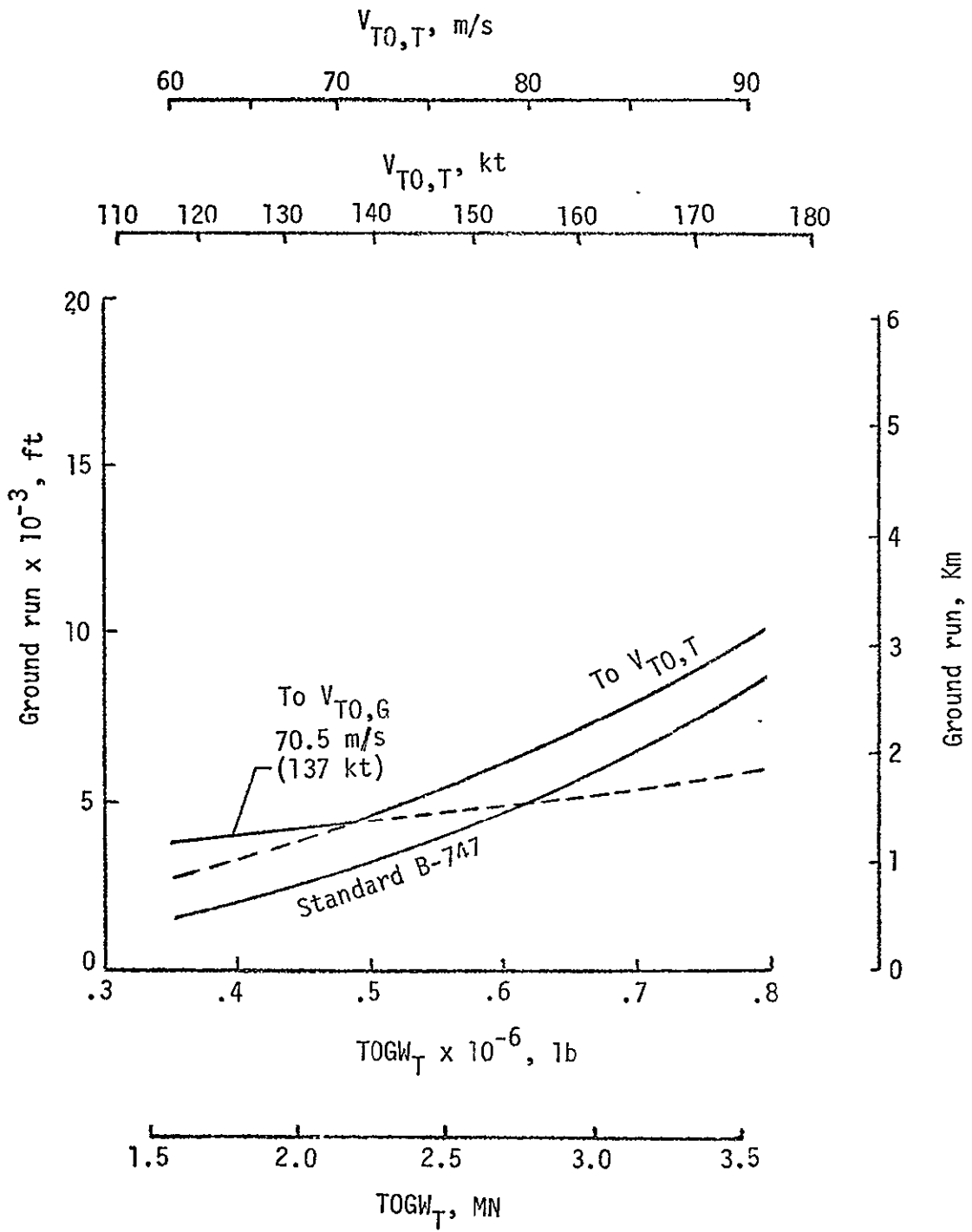

(b) 6 engines

Figure 8. - Concluded.

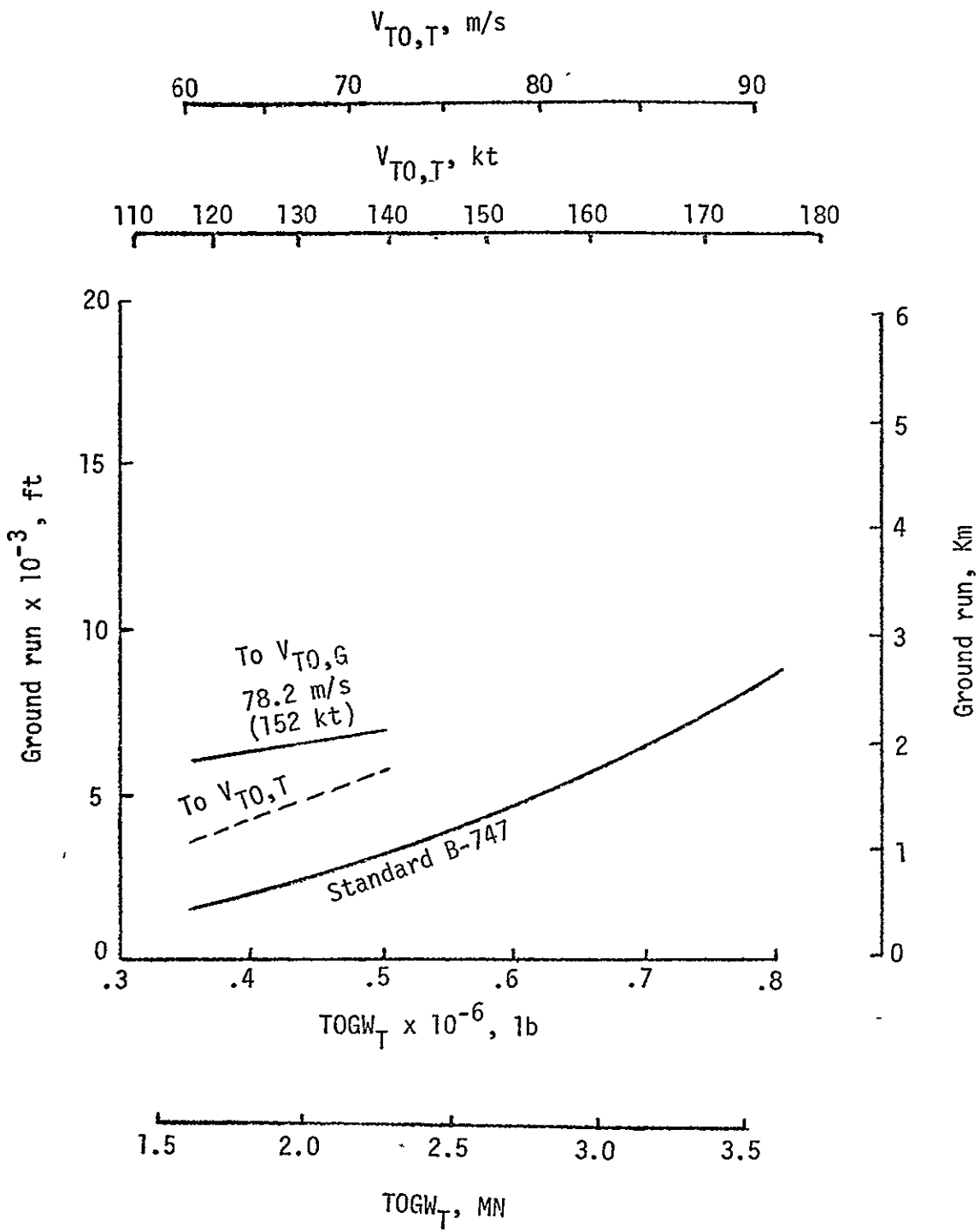

(a) $A = 25$, $TOGW_G = 3.614$ MN (812 500 lb).

Figure 9. - Ground run required by powered glider with B-747 tug.

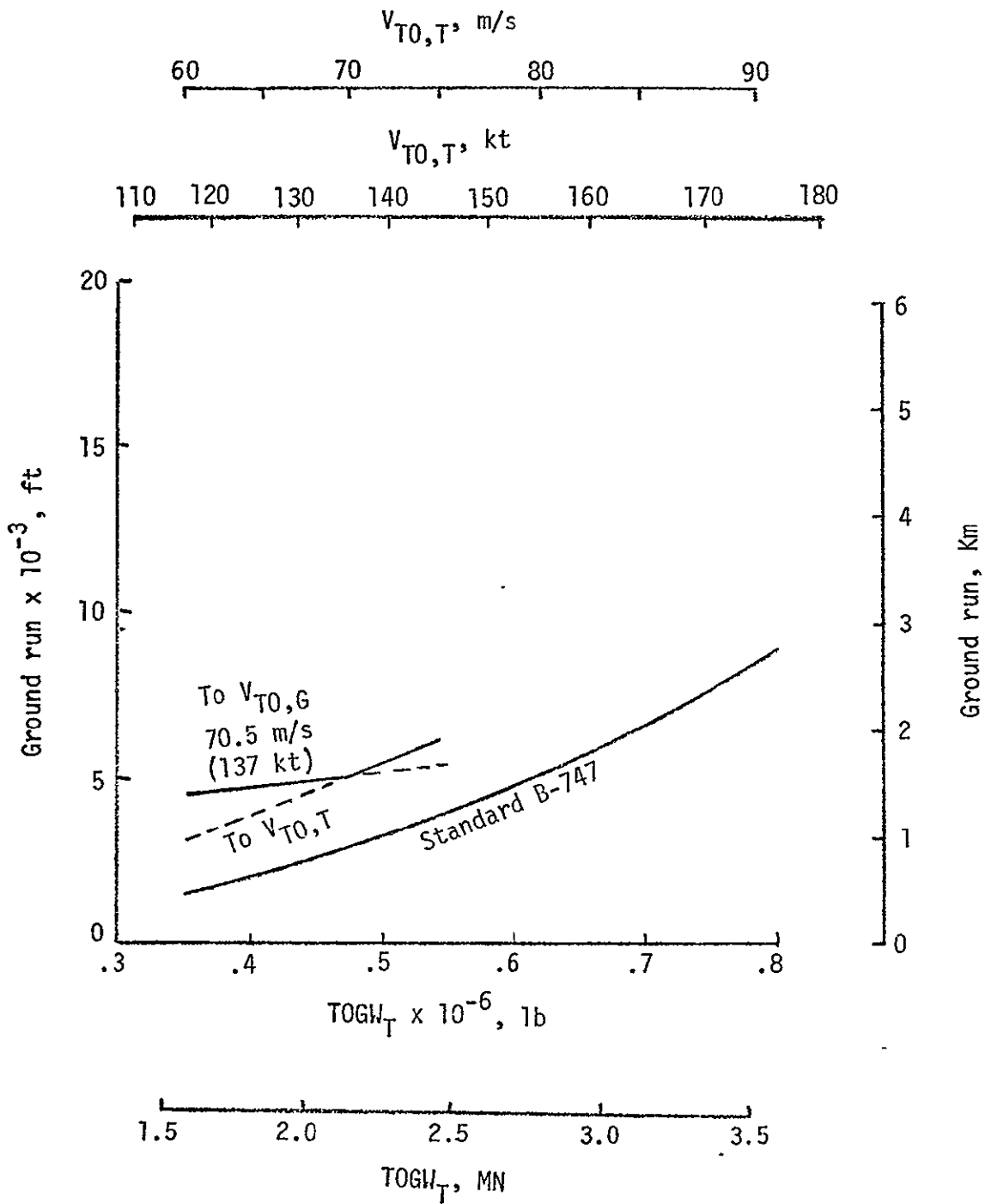

(b) $A = 14$, $TOGW_G = 3.048$ MN (685 170 lb).

Figure 9. - Concluded.

ORIGINAL PAGE IS
OF POOR QUALITY

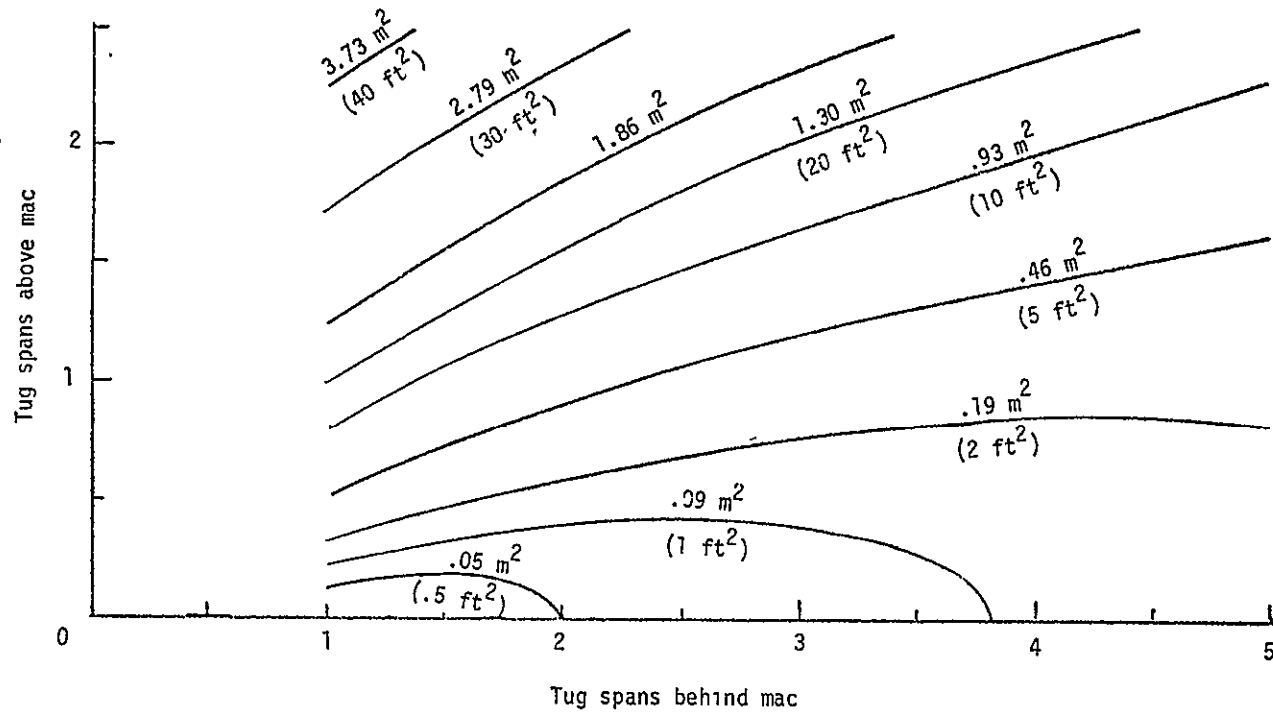
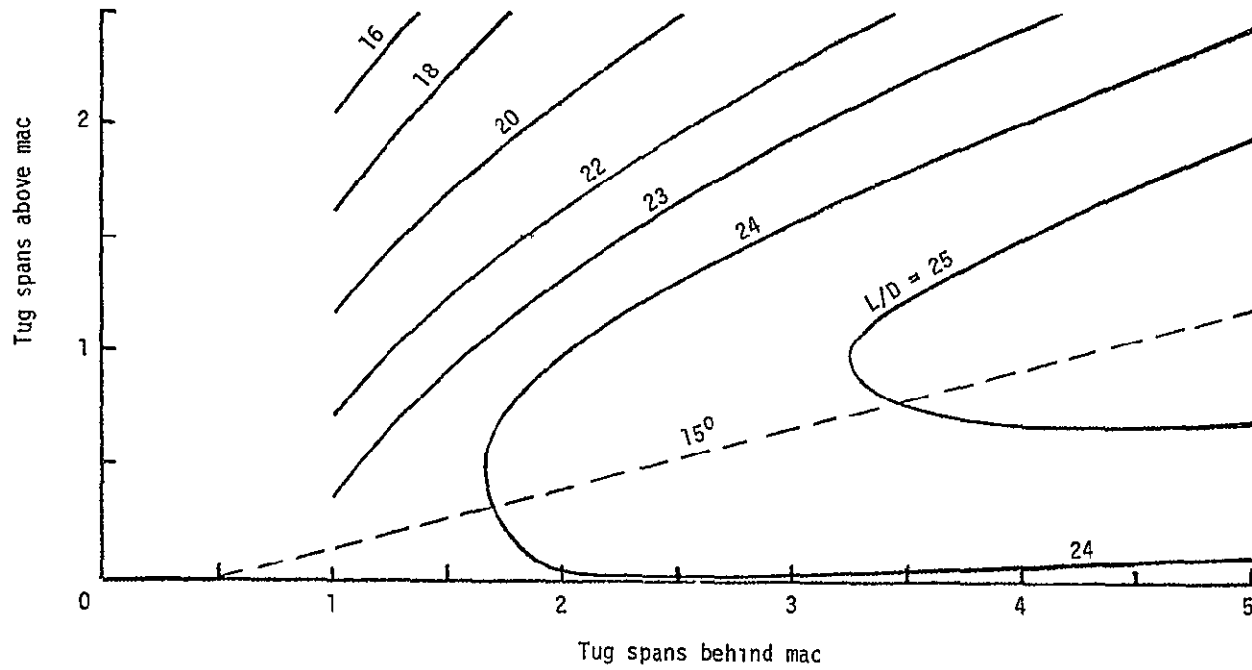
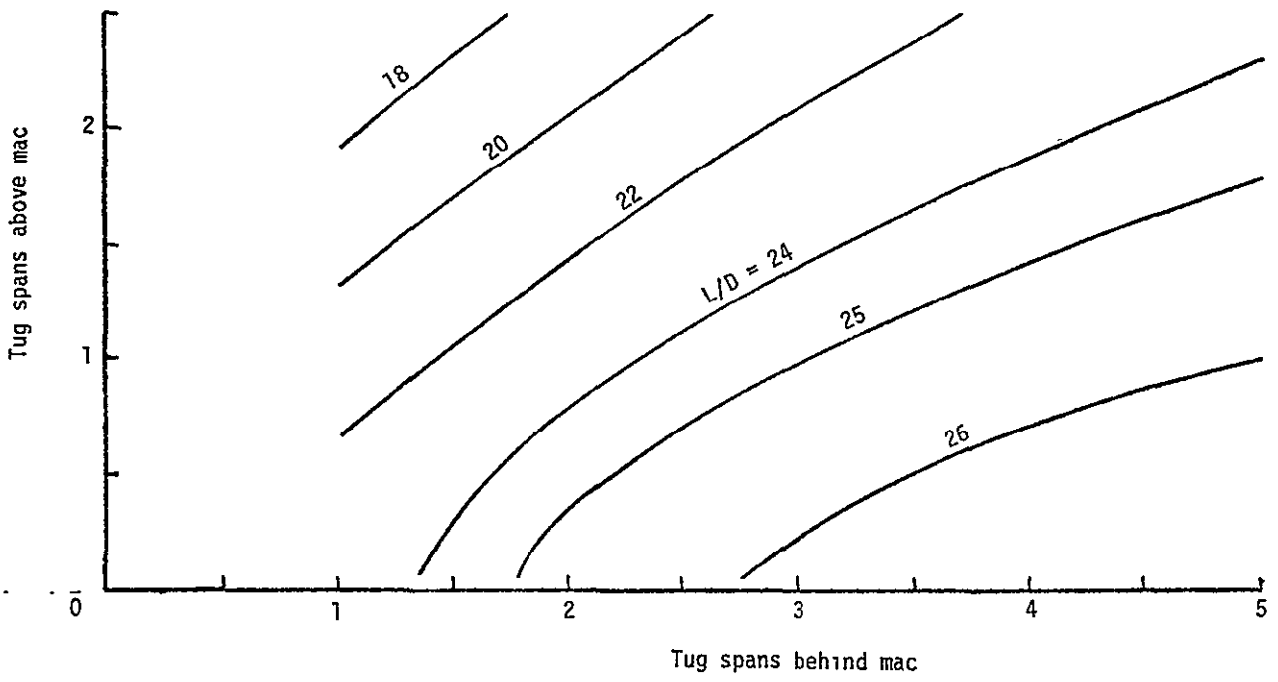

Figure 10. - Equivalent flat-plate-drag area as a function of glider position behind B-747 tug. 2.54 cm (1.0 in) cable diameter.



(a) In-line tow.

Figure 11. - Sample calculation of the effective lift-drag ratio as a function of the glider position behind a B-747 tug. Assumptions are as follows. $(L/D)_T = 18$, $(L/D)_G = 28$; $C_{LT} = 0.6$, $C_{LG} = 0.45$; $A_T = 6.96$, $A_G = 25$; $b_T = 59.6$ m (195.7 ft), $b_G = 118.0$ m (387.3 ft); cable diameter = 2.54 cm (1.0 in)



(b) Glider 1.0 tug span to side of tug.

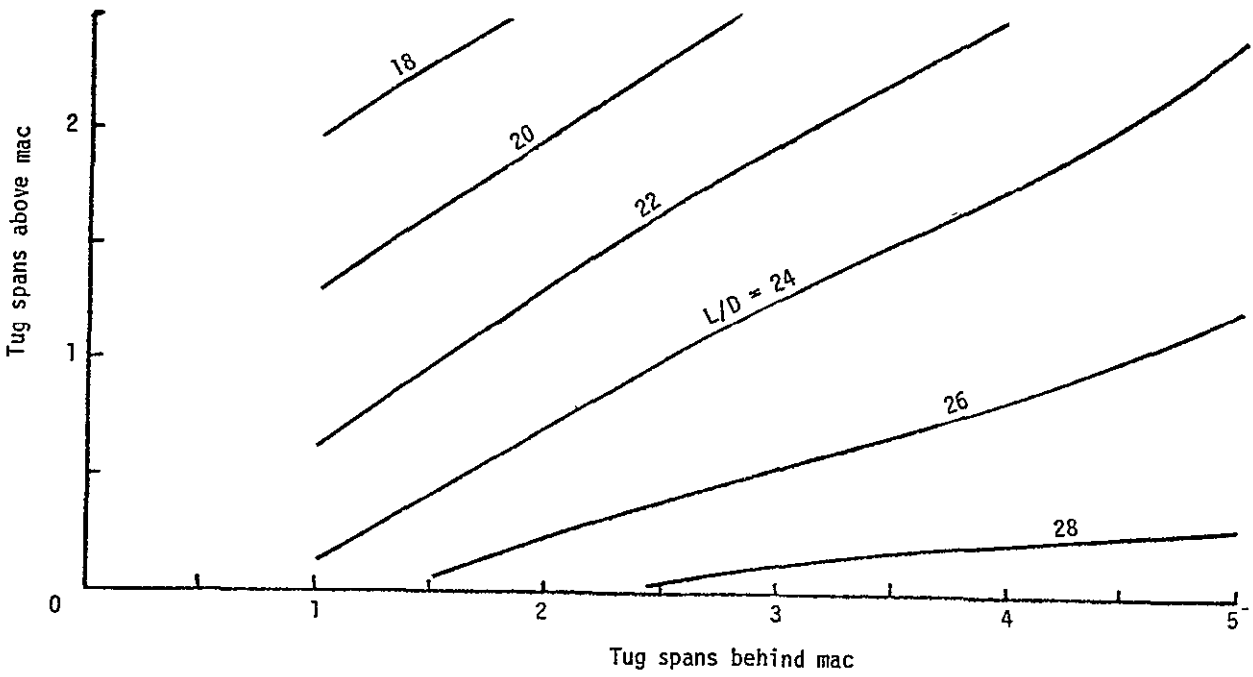

(c) Glider 1.25 tug span to side of tug.

Figure 11. - Continued.

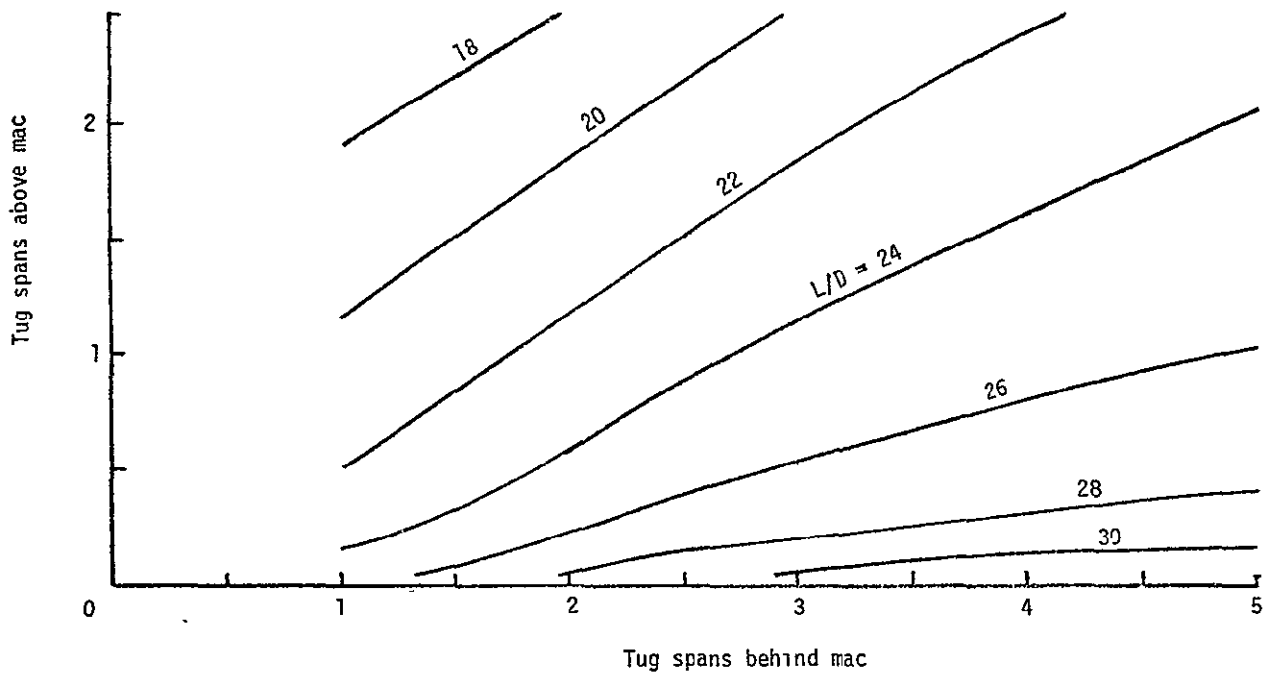

(d) Glider 1.50 tug span to side of tug.

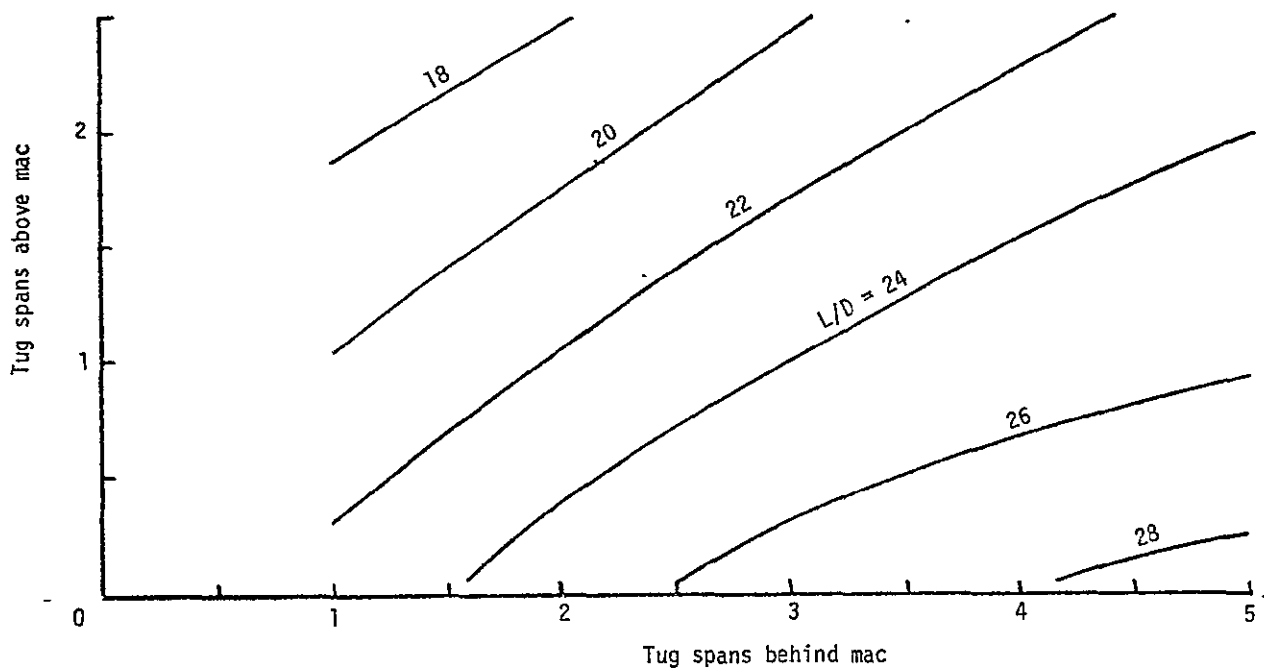

(e) Glider 1.75 tug span to side of tug.

Figure 11. - Concluded.

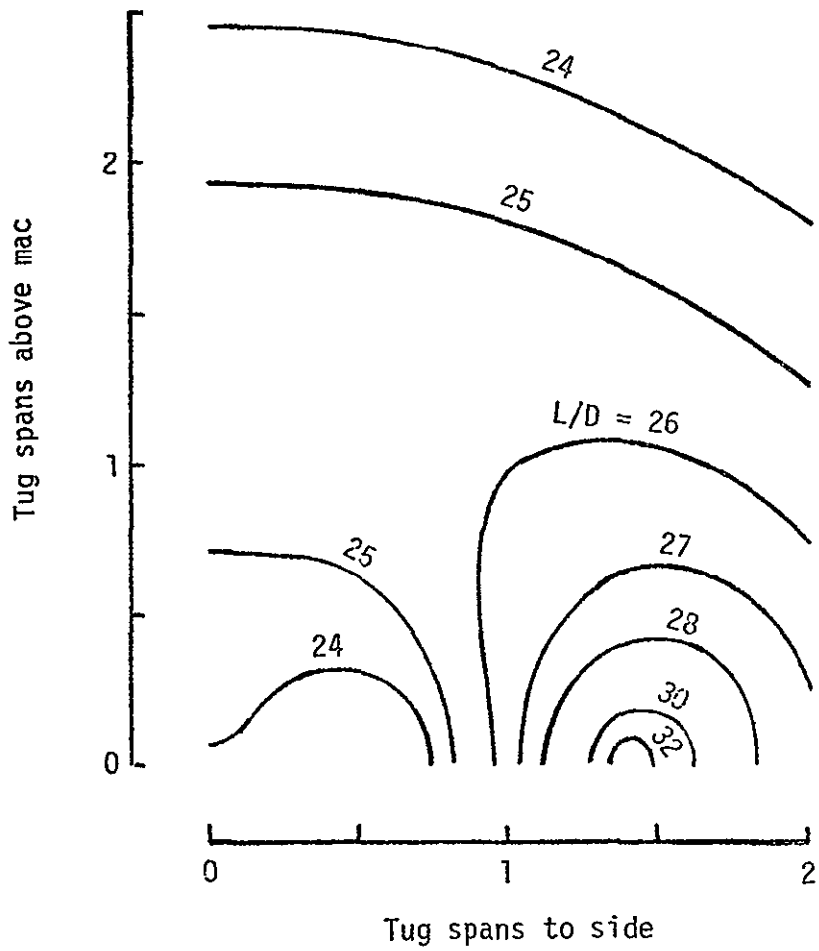

Figure 12. - Sample calculation of the effective lift-drag ratio of a glider towed 5 tug spans behind a B-747. Assumptions are the same as those of figure 11.

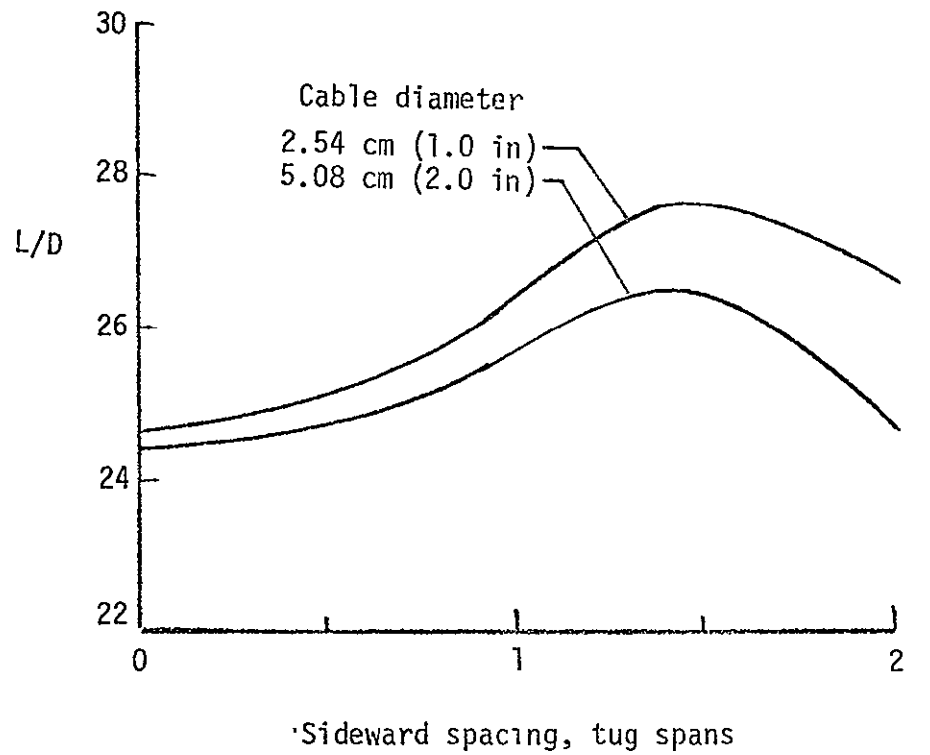

Figure 13. - Effective lift-drag ratio of the glider of figures 11 and 12 when towed 0.5 tug span above wake and 5.0 tug spans behind the tug mac.

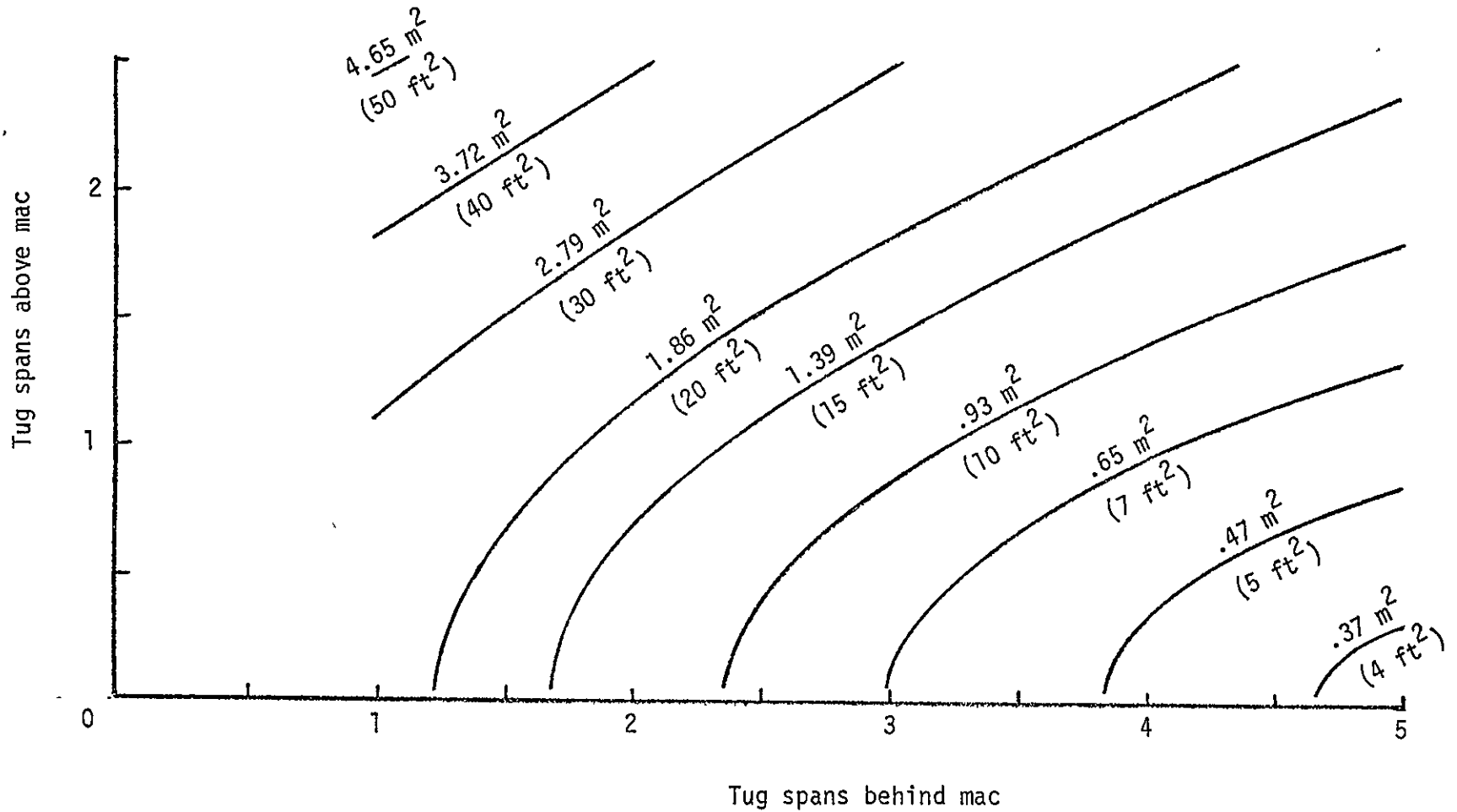
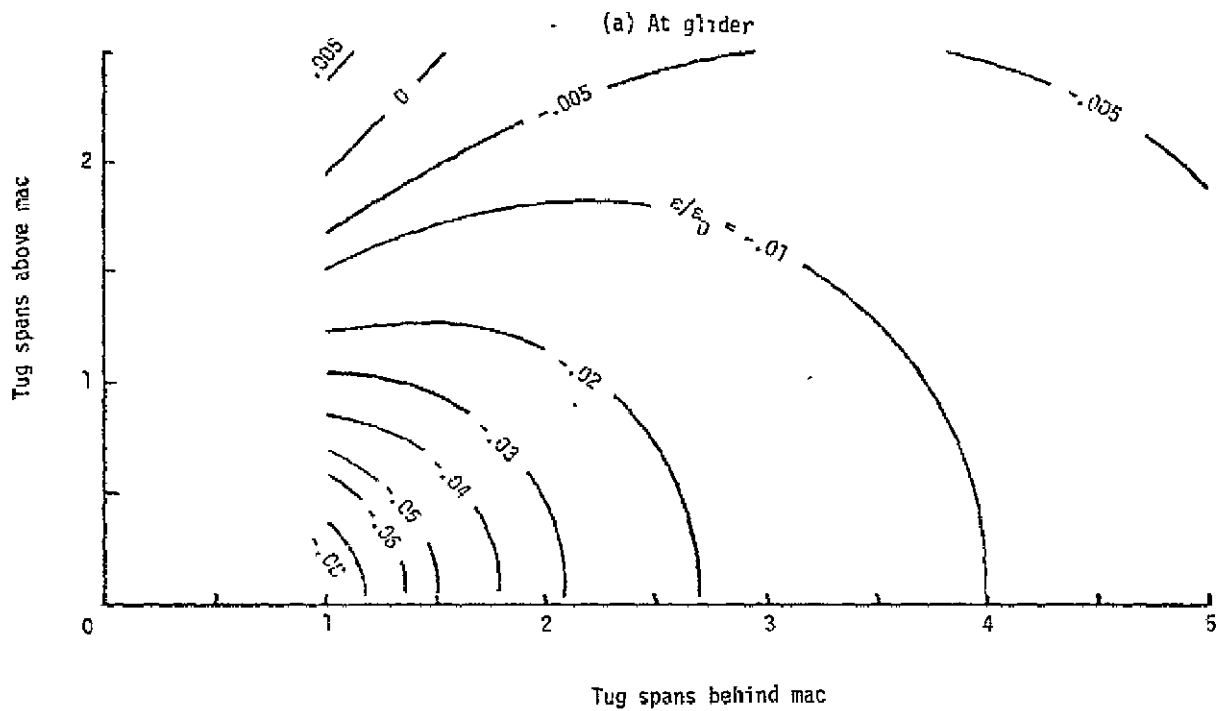
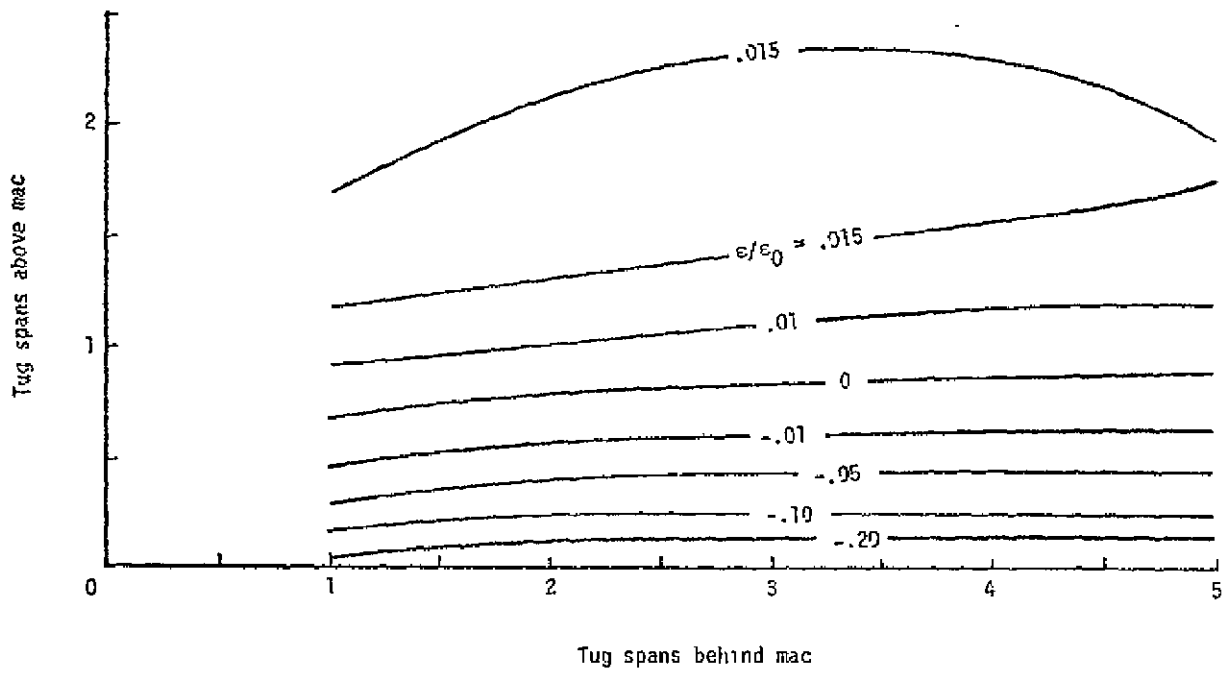
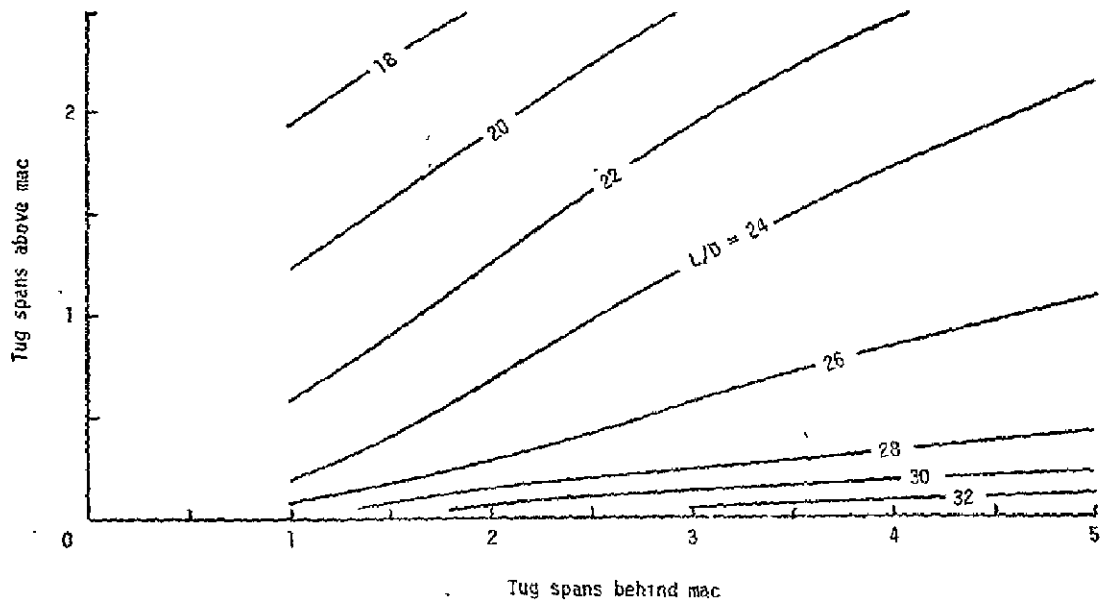

Figure 14. - Flat-plate-drag area of cable per 2.54 cm (1.0 in) of diameter when towing glider behind and 1.4 tug spans to side of B-747. Assumptions are those of figure 11.



(b) At tug.

Figure 15. - Nondimensional downwash angle ϵ/ϵ_0 for glider behind and 1.4 tug spans to side of B-747 tug. Assumptions are those of figure 11.



(a) Glider

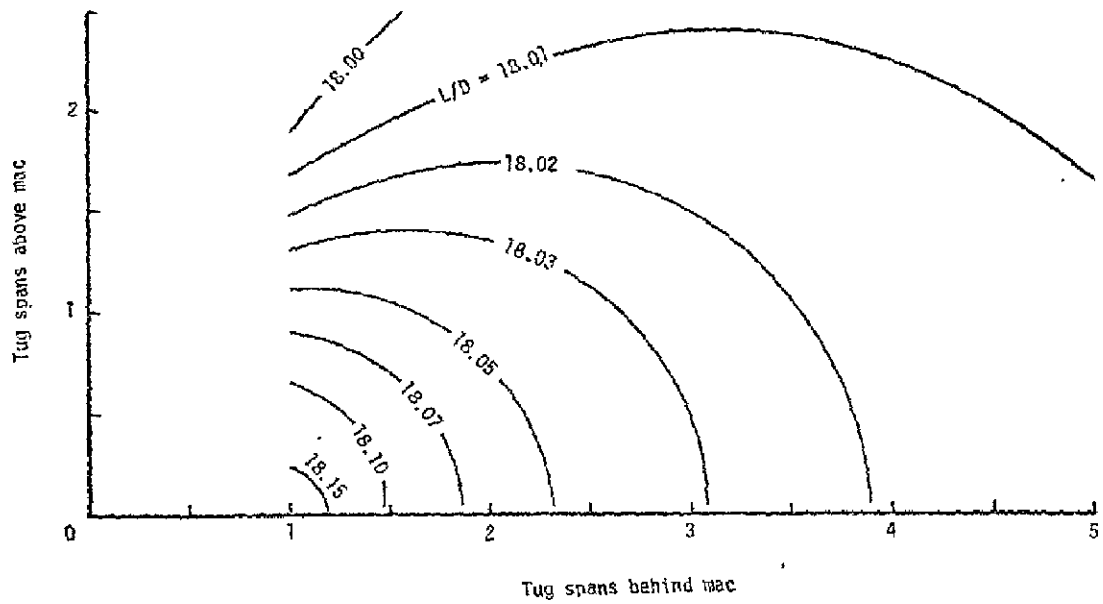

(b) Tug

Figure 16. Sample calculation of effective lift-drag ratio for B-747 tug towing a glider 1.4 tug spans to the side. Assumptions are those of figure 11.

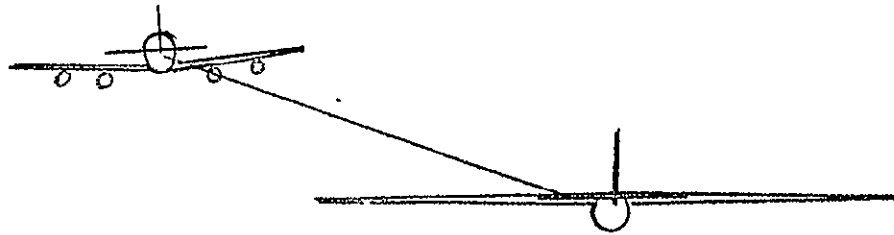

Figure 17. - Approximate relative positions of tug and glider.

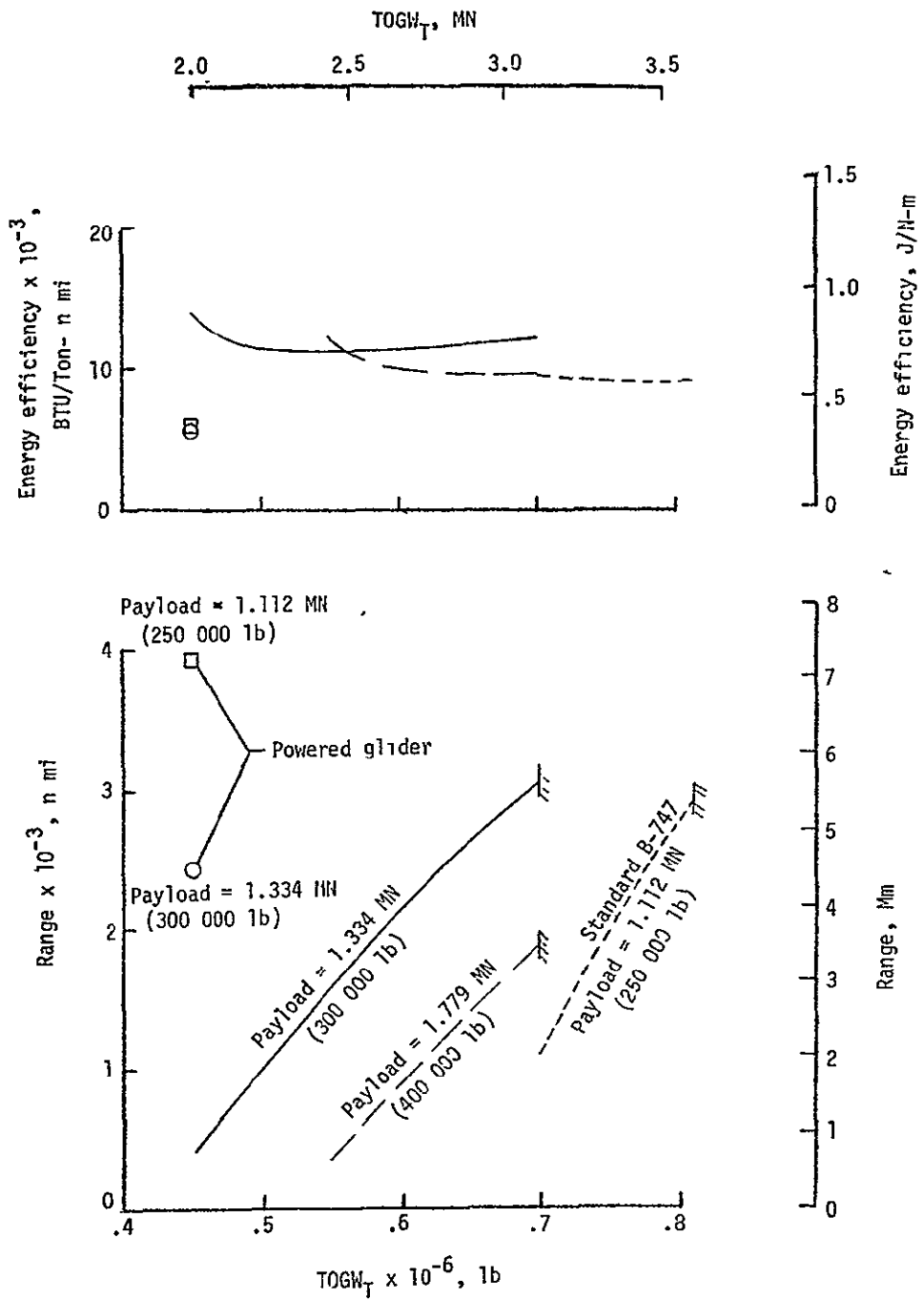

Figure 18. - Range performance and energy efficiency for tug-glider combinations. Unpowered gliders use six-engine B-747 tugs. A = 25.

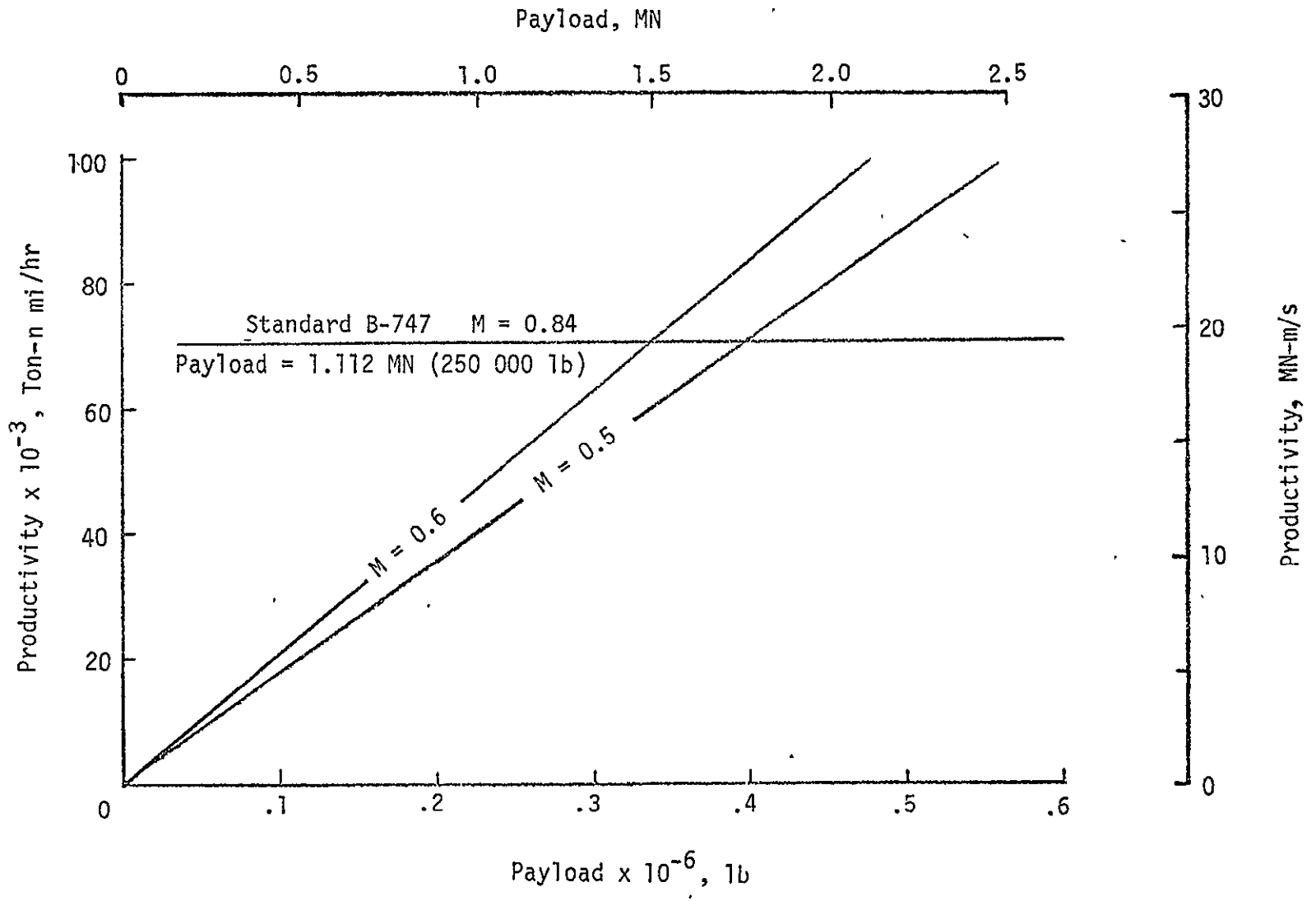

Figure 19. - Productivity as a function of Mach number and payload.

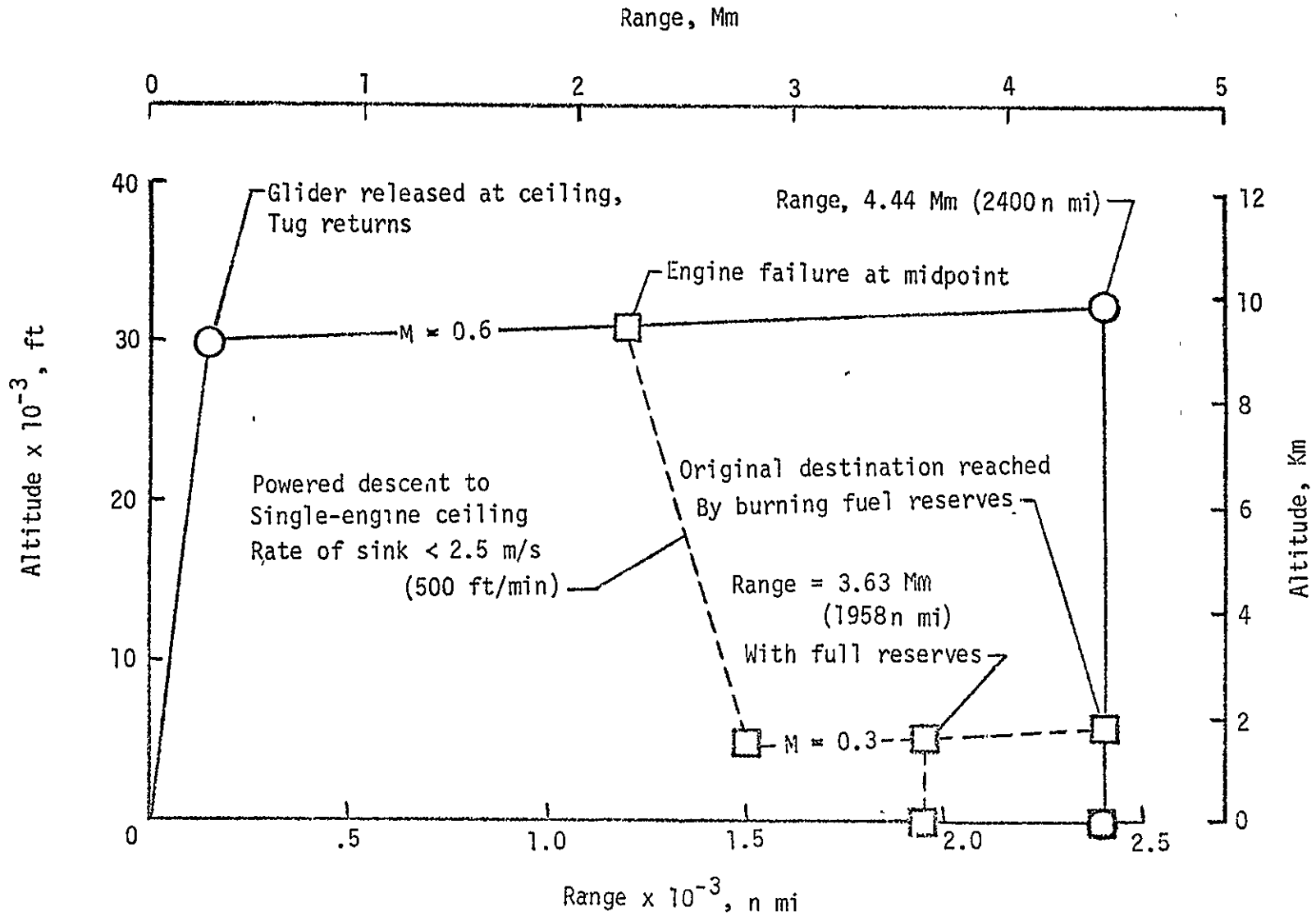

Figure 20. - Flight profiles for powered glider ($A = 25$) using a B-747 tug for takeoff and climb to altitude. $TOGW_T = 2.002 \text{ MN}$ (450 000 lb), $TOGW_G = 3.614 \text{ MN}$ (812 500 lb), payload = 1.334 MN (300 000 lb).

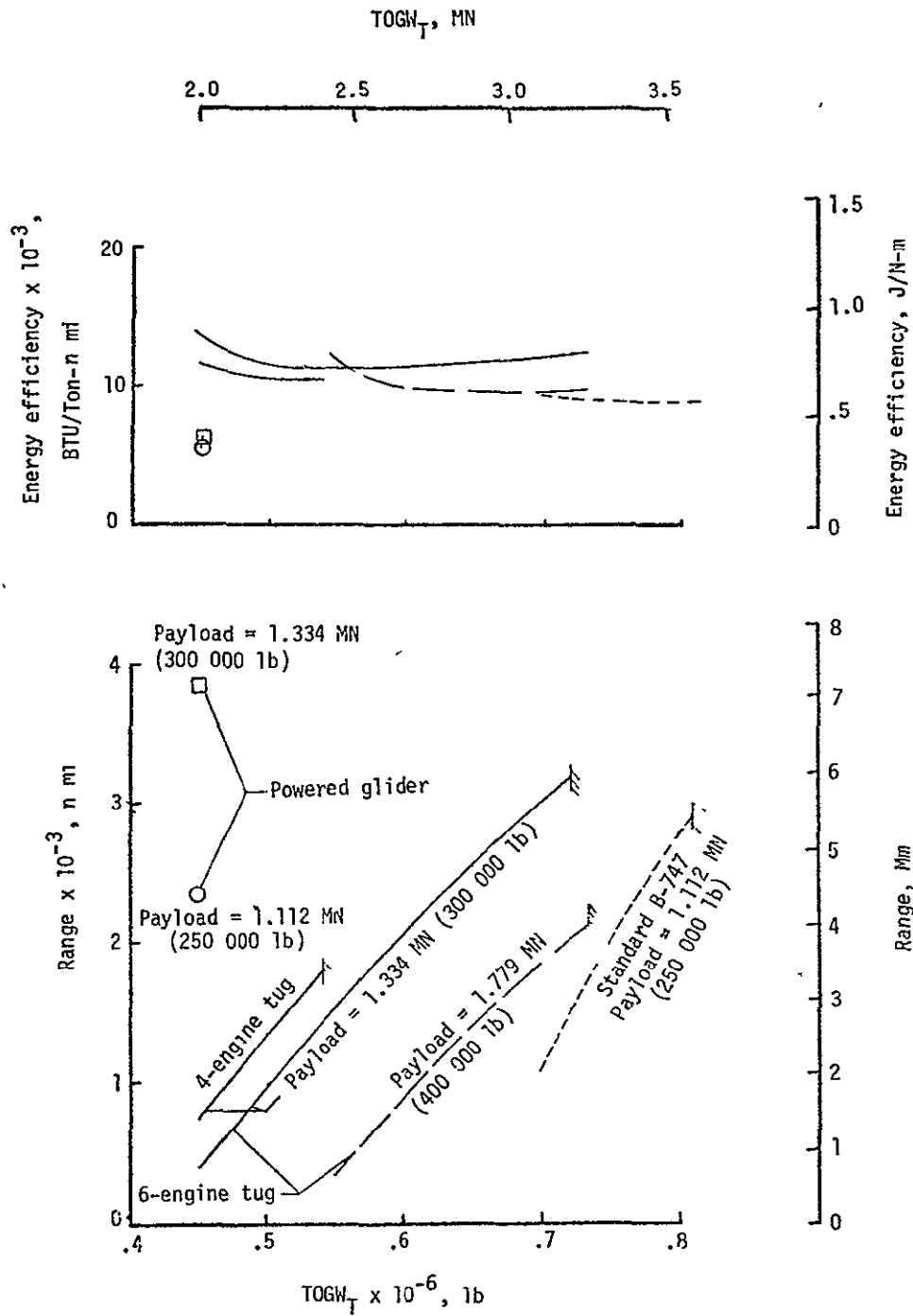

Figure 21. - Range performance and energy efficiency for tug-glider combinations. A = 14.

ORIGINAL PAGE IS
OF POOR QUALITY

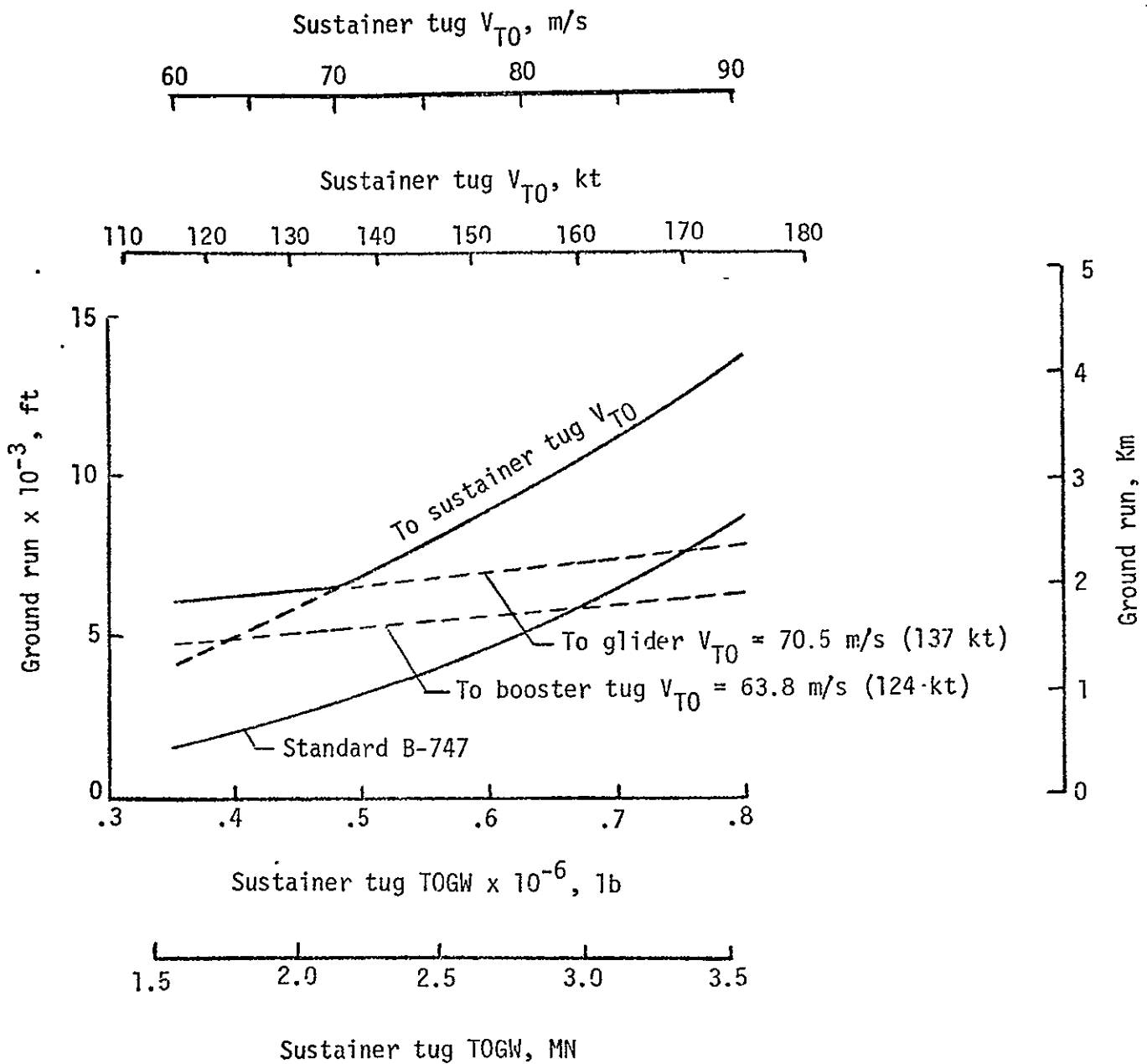

Figure 22. - Ground run required by large glider with two B-747 tugs.
 $TOGW_G = 4.448 \text{ MN}$ (1 000 000 lb), $b_G = 121.3 \text{ m}$ (398 ft),
 Payload = 2.516 MN (565 500 lb).

UNIT	BOOSTER TUG	SUSTAINER TUG	CARGO GLIDER
TOGW, MN lb	1.779 400 000	2.669 600 000	4.448 1 000 000
Fuel, Mg lb	5.443 12 000	99.354 219 038	- -
Payload, MN lb	- -	- -	2.516 565 500

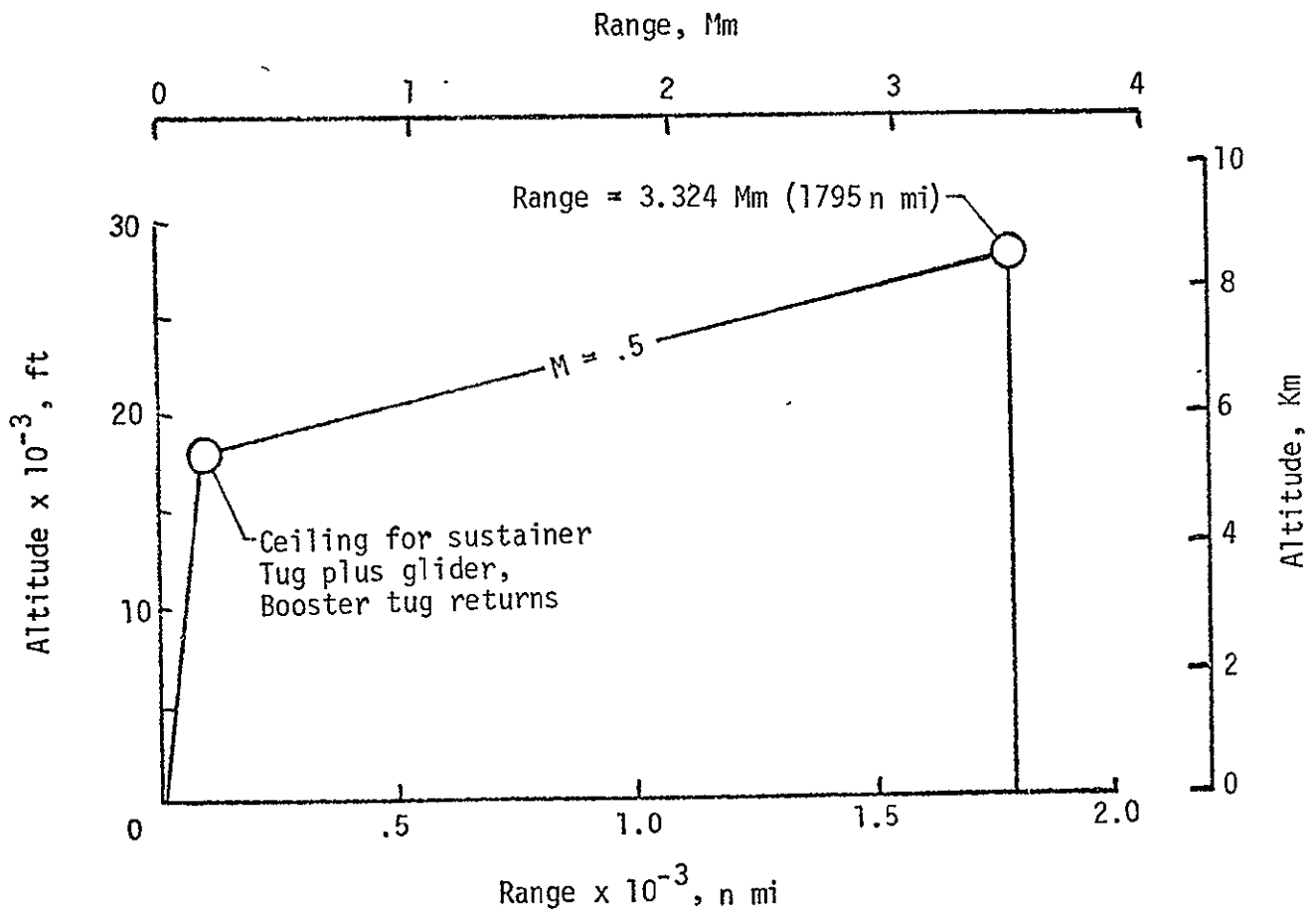

Figure 23. - Maximum performance mission of 4.448 MN (1 000 000 lb) glider (A = 14) with B-747 booster and sustainer tugs. Energy efficiency is 0.542 J/Nm (8465 BTU/Ton-n mi).