

General Disclaimer

One or more of the Following Statements may affect this Document

- This document has been reproduced from the best copy furnished by the organizational source. It is being released in the interest of making available as much information as possible.
- This document may contain data, which exceeds the sheet parameters. It was furnished in this condition by the organizational source and is the best copy available.
- This document may contain tone-on-tone or color graphs, charts and/or pictures, which have been reproduced in black and white.
- This document is paginated as submitted by the original source.
- Portions of this document are not fully legible due to the historical nature of some of the material. However, it is the best reproduction available from the original submission.

**NASA TECHNICAL
MEMORANDUM**

NASA TM X-73605

NASA TM X-73605

(NASA-TM-X-73605) THERMODYNAMIC DATA REPORT
FOR THE TITAN/CENTAUR TC-5 EXTENDED MISSION
(NASA) 47 p HC A03/MF A01 CSCL 22B

N77-18182

Unclas

G3/15

13952

**THERMODYNAMIC DATA REPORT FOR THE
TITAN/CENTAUR TC-5 EXTENDED MISSION**

by Raymond F. Lacovic
Lewis Research Center
Cleveland, Ohio 44135
January 1977



1. Report No. NASA TM X-73605	2. Government Accession No.	3. Recipient's Catalog No.	
4. Title and Subtitle THERMODYNAMIC DATA REPORT FOR THE TITAN/CENTAUR TC-5 EXTENDED MISSION		5. Report Date	
		6. Performing Organization Code	
7. Author(s) Raymond F. Lacovic		8. Performing Organization Report No. E-9080	
		10. Work Unit No.	
9. Performing Organization Name and Address Lewis Research Center National Aeronautics and Space Administration Cleveland, Ohio 44135		11. Contract or Grant No.	
		13. Type of Report and Period Covered Technical Memorandum	
12. Sponsoring Agency Name and Address National Aeronautics and Space Administration Washington, D. C. 20546		14. Sponsoring Agency Code	
		15. Supplementary Notes	
16. Abstract <p>The Titan/Centaur vehicle, with the Helios B spacecraft, was launched on January 15, 1976. After the spacecraft was placed into its desired heliocentric trajectory, the Centaur vehicle continued into an extended mission to perform experiments demonstrating increased operational capabilities. One of the primary objectives of this "extended mission" was to evaluate the thermal performance of all pertinent Centaur systems and components and to verify their capability for satisfactory operation for long duration space coasts. This objective was successfully accomplished. The flight data show that the selected thermal control techniques maintained the Centaur component temperatures within their qualification limits for the entire 8-hour and 22-minute duration of the extended mission. There were no significant component temperature anomalies or discrepancies.</p>			
17. Key Words (Suggested by Author(s)) Thermodynamics; Propellants; Launch vehicle; Heat transfer; Cryogenics		18. Distribution Statement Unclassified - unlimited	
19. Security Classif. (of this report) Unclassified	20. Security Classif. (of this page) Unclassified	21. No. of Pages	22. Price*

SUMMARY

The Titan/Centaur vehicle, with the Helios B spacecraft, was launched on January 15, 1976. After the spacecraft was placed into its desired heliocentric trajectory, the Centaur vehicle continued into an extended mission to perform experiments demonstrating increased operational capabilities. One of the primary objectives of this "extended mission" was to evaluate the thermal performance of all pertinent Centaur systems and components and to verify their capability for satisfactory operation for long duration space coasts. This objective was successfully accomplished. The flight data show that the selected thermal control techniques maintained the Centaur component temperatures within their qualification limits for the entire 8-hour and 22-minute duration of the extended mission. There were no significant component temperature anomalies or discrepancies.

INTRODUCTION

E-9080

The Titan/Centaur vehicle TC-5, with the Helios B spacecraft, was launched from the Eastern Test Range on January 15, 1976. The primary mission included a Centaur first main engine firing to place the vehicle in a 90 n.mi. parking orbit. After a 28-minute low gravity coast with settled propellants, the Centaur engines were fired for a second time in order to place the spacecraft into its desired heliocentric trajectory. After spacecraft separation the Centaur vehicle continued into an "extended mission" in order to perform a series of experiments with the Centaur stage.

The extended mission started with a 5.25-hour zero gravity coast to demonstrate the Centaur synchronous orbit coast capability. This coast was followed by 5 engine start experiments separated by low or zero gravity coasts of from 5 minutes to 120 minutes duration. The total duration of the extended mission was 8 hours and 22 minutes.

One of the primary objectives of the extended mission was to evaluate the thermal performance of all pertinent Centaur systems and components and to verify their capability for satisfactory operation for long duration space coasts. The flight results and data relevant to this verification are presented in this report. The flight temperature history; the thermal control technique used, and the qualification limits are presented herein for the individual Centaur systems and components. This report is an extension and supplement to the TC-5 Helios B Flight Data Report (NASA TMX-73435) which presented the Centaur system data from liftoff through spacecraft separation.

EXTENDED MISSION SEQUENCING AND FLIGHT ENVIRONMENT

The thermal control philosophy for Centaur long coast operation is to provide a thermal environment which with minor coating changes, mount insulation, and/or radiation shielding additions would permit existing components to operate within their current qualification limits. Preliminary thermodynamic evaluations of component temperatures indicated that continuous shadow or solar heating periods of 1-1/2 hours or longer would generally produce overchilling or overheating which would require either the addition of heaters or a major redesign. For this reason long coast Centaur missions required a thermal roll maneuver which would make alternating periods of solar heating and vehicle shadowing available to all components. For the thermal roll maneuver to be effective, the vehicle had to maintain a proper cone angle with respect to the sun. The required solar cone angle is $90^{\circ}-25^{\circ}/+40^{\circ}$ to provide solar heating to both the forward and aft end components. For the TC-5 extended mission two types of thermal roll maneuvers were selected for evaluation. The first maneuver was a continuous slow roll at $0.1^{\circ}/\text{sec.}$ and the second maneuver was a periodic 135° fast roll (at $2^{\circ}/\text{sec.}$) performed at 42-minute intervals.

The sequencing of these thermal roll maneuvers, together with the resulting solar clock and cone angles, is shown in figure 1. The angles shown are approximate since wide control limits ($\pm 10^{\circ}$) were used throughout most of the mission. The vehicle-sun clock angle changed continuously during the mission as the various thermal rolls were performed. The vehicle-sun cone angle remained relatively constant at about 75° to provide continuous vehicle broadside heating. This cone angle resulted in a near maximum heating environment for the LH_2 tank and forward components and a slightly less than nominal heating environment for the aft bulkhead components. The vehicle was far enough away from the Earth that the thermal and albedo radiation from the Earth were negligible.

A listing of the thermal roll sequencing times, and the major flight events that affect the vehicle thermal performance, is shown in table 1. There were 5 engine starts during the extended mission separated by coast periods ranging from 5 minutes to 315 minutes, one continuous slow roll of 90 minutes duration, 8 fast thermal roll maneuvers about 42 minutes apart, and the propellant tanks were vented twice near the end of the mission. All of the coasts were zero gravity coasts with the exception of the 5-minute coast between MECO-5 and MES-6 during which a low level 12-pound thrust was continuously applied.

TABLE 1

TC-5 Extended Mission Sequencing Summary

<u>Event</u>	<u>Time From Liftoff (Hrs.: Min.: Sec.)</u>
Main Engine Cutoff 2 (MECO-2)	0:42:54
Spacecraft Separation	0:44:06
Start Slow Thermal Roll	1:17:56
H ₂ O ₂ S Engine Warming Firing (10 Seconds)	2:13
End Slow Thermal Roll	2:47:54
Initiate Fast Thermal Roll 1	3:29:26
H ₂ O ₂ S Engine Warming Firing	3:48
Initiate Fast Thermal Roll 2	4:10:56
Initiate Fast Thermal Roll 3	4:52:26
H ₂ O ₂ S Engine Warming Firing	5:23
Initiate Fast Thermal Roll 4	5:33:56
Start Propellant Settling	5:50:55
Main Engine Start 3 (MES-3)	5:57:55
MECO-3	5:58:06
Initiate Fast Thermal Roll 5	6:18:56
Start Propellant Settling	6:23:36
MES-4	6:28:06
MECO-4	6:28:19
Start Propellant Settling	6:43:49
MES-5	6:48:19
MECO-5	6:48:25
MES-6	6:53:25
MECO-6	6:53:31
Initiate Fast Thermal Roll 6	7:03:32
Initiate Fast Thermal Roll 7	7:48:32
H ₂ O ₂ S Engine Warming Firing	7:53
Propellant Tank Vent Occurs	8:25:10
Initiate Fast Thermal Roll 8	8:33:32
Start Propellant Settling	8:51:01
MES-7	8:53:31
MECO-7	8:53:38
Vent Propellant Tanks	8:59:38
Mission Complete	9:06:58

REPRODUCIBILITY OF THE ORIGINAL PAGE IS POOR

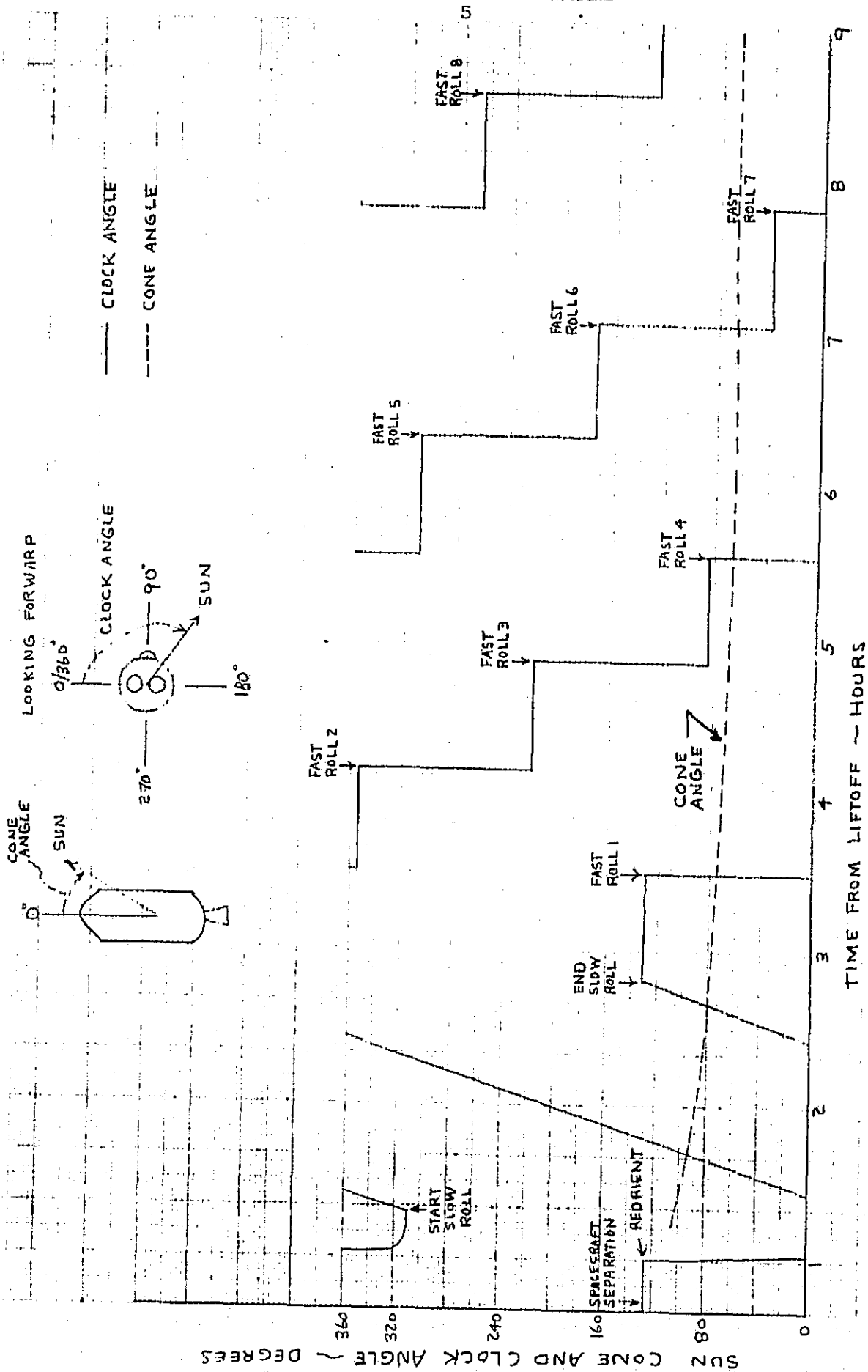

FIGURE 1 EXTENDED MISSION VEHICLE - SUN CLOCK AND CONE ANGLE HISTORY.

VEHICLE CONFIGURATION

The basic Titan/Centaur vehicle configuration is described in the Centaur D-1T Systems Summary (GDC Report No. CASD-LVP73-007) and the TC-5 vehicle peculiar configurations are described in the TC-5 Helios B Flight Data Report.

The thermal control techniques used for structural elements and system components are generally described system by system in the respective discussion areas of this report. Thermal control for various components was provided by use of such devices as white paint, aluminized enamel, aluminized mylar tape, irradiated surface treatment, radiation shielding, and electrical heaters.

The three layer radiation shield used extensively on the D-1T Centaur vehicle is comprised of three layers of an aluminized mylar-dacron net (scrim) sandwich. The inner and middle layers are identical in construction with a dacron scrim between two sheets of aluminized mylar. The outer layer is of similar construction except that the outer mylar sheet is plain, not aluminized. The outer and middle layers have 1/4-inch vent holes to permit rapid venting of the shielding. The inner layer has no holes and serves as a leakage containment membrane.

FLIGHT INSTRUMENTATION

The TC-5 Centaur vehicle was extensively instrumented to provide engineering data during the extended mission. The locations of the instruments pertinent to the results discussed in this report are shown in figures 2A through 2H. All of this instrumentation behaved normally throughout the flight and no anomalies were observed.

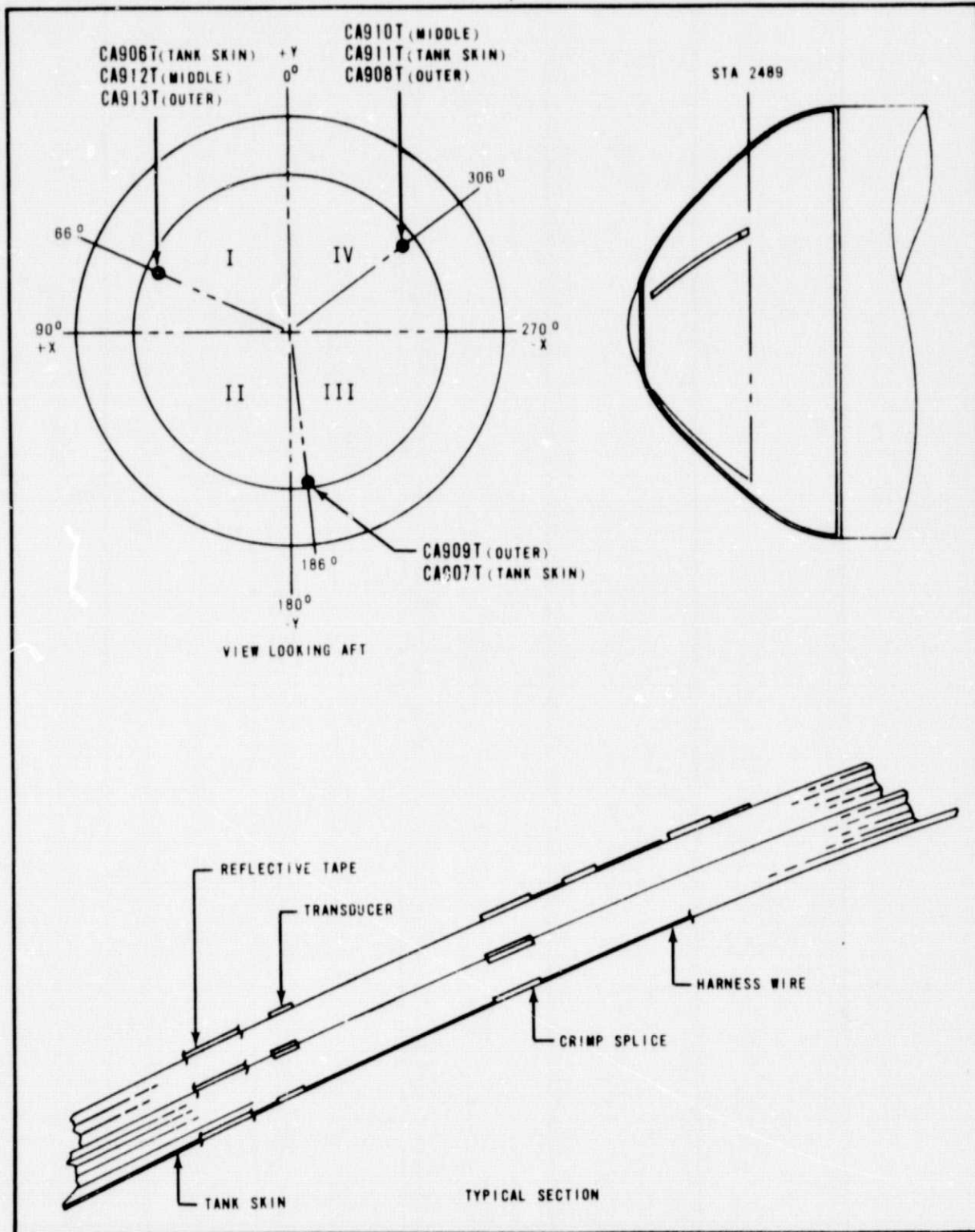

Figure 2A CENTAUR Forward Bulkhead Temperatures

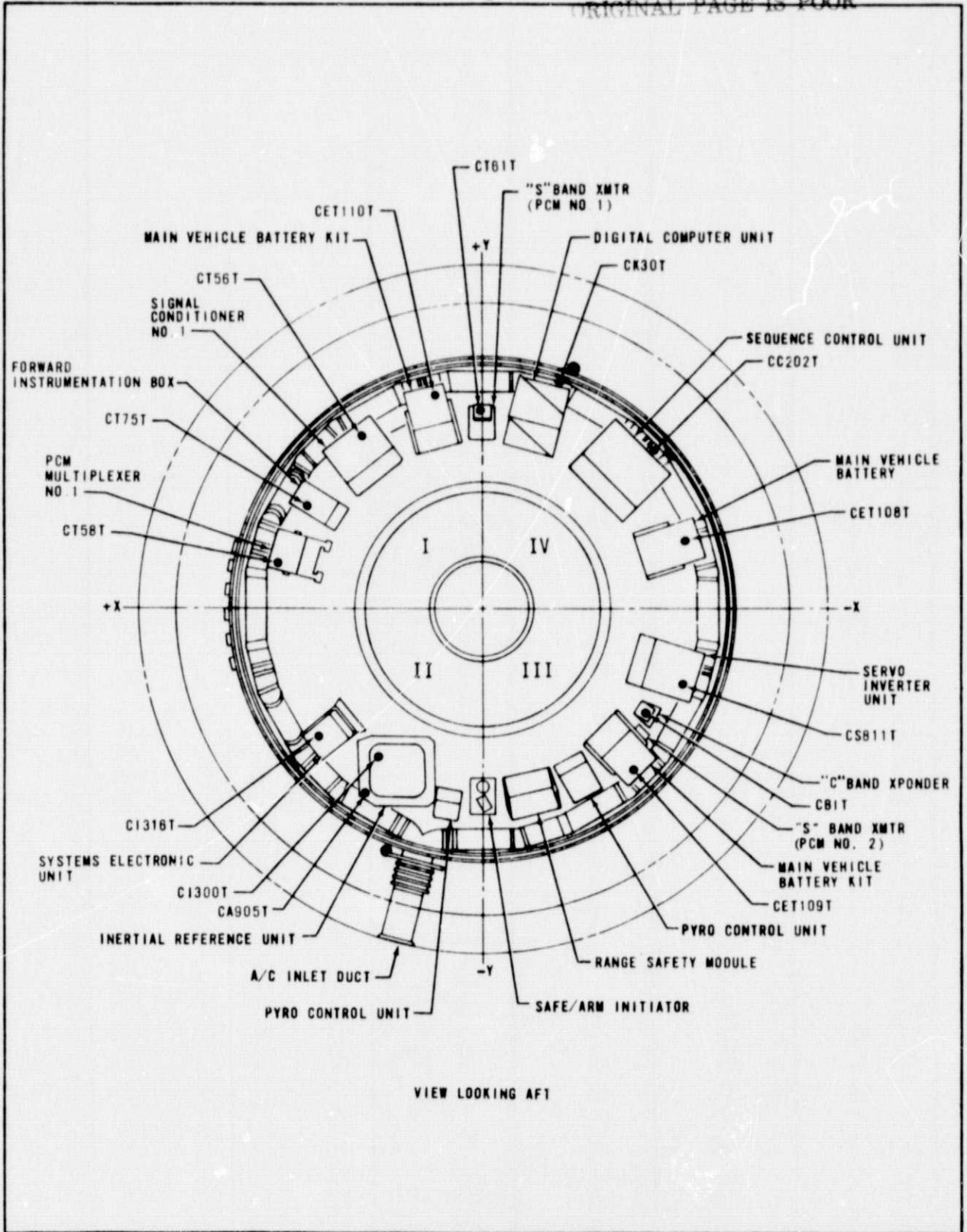

Figure 2B CENTAUR Forward Equipment Module

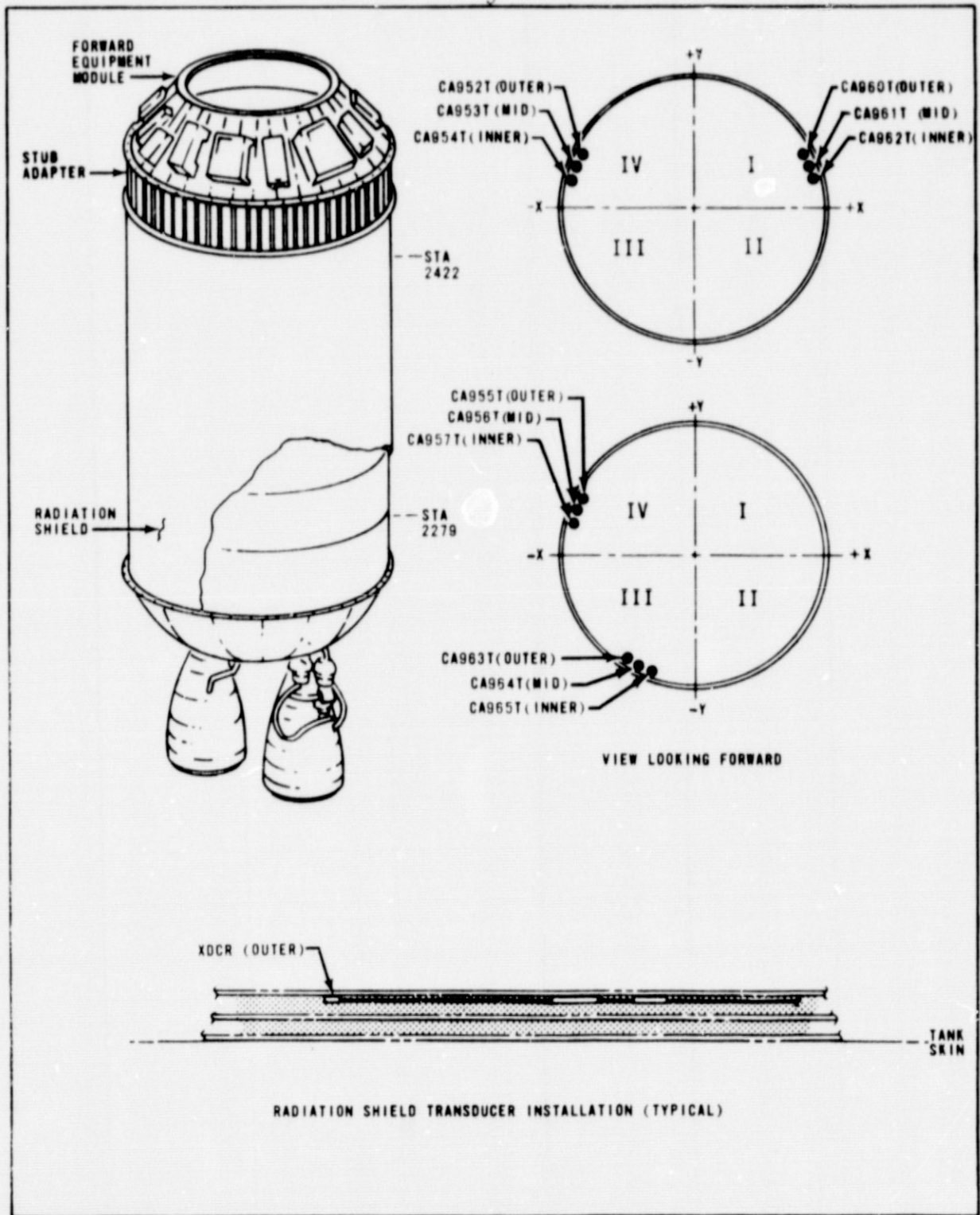

Figure 2C CENTAUR Tank Radiation Shield Temperature

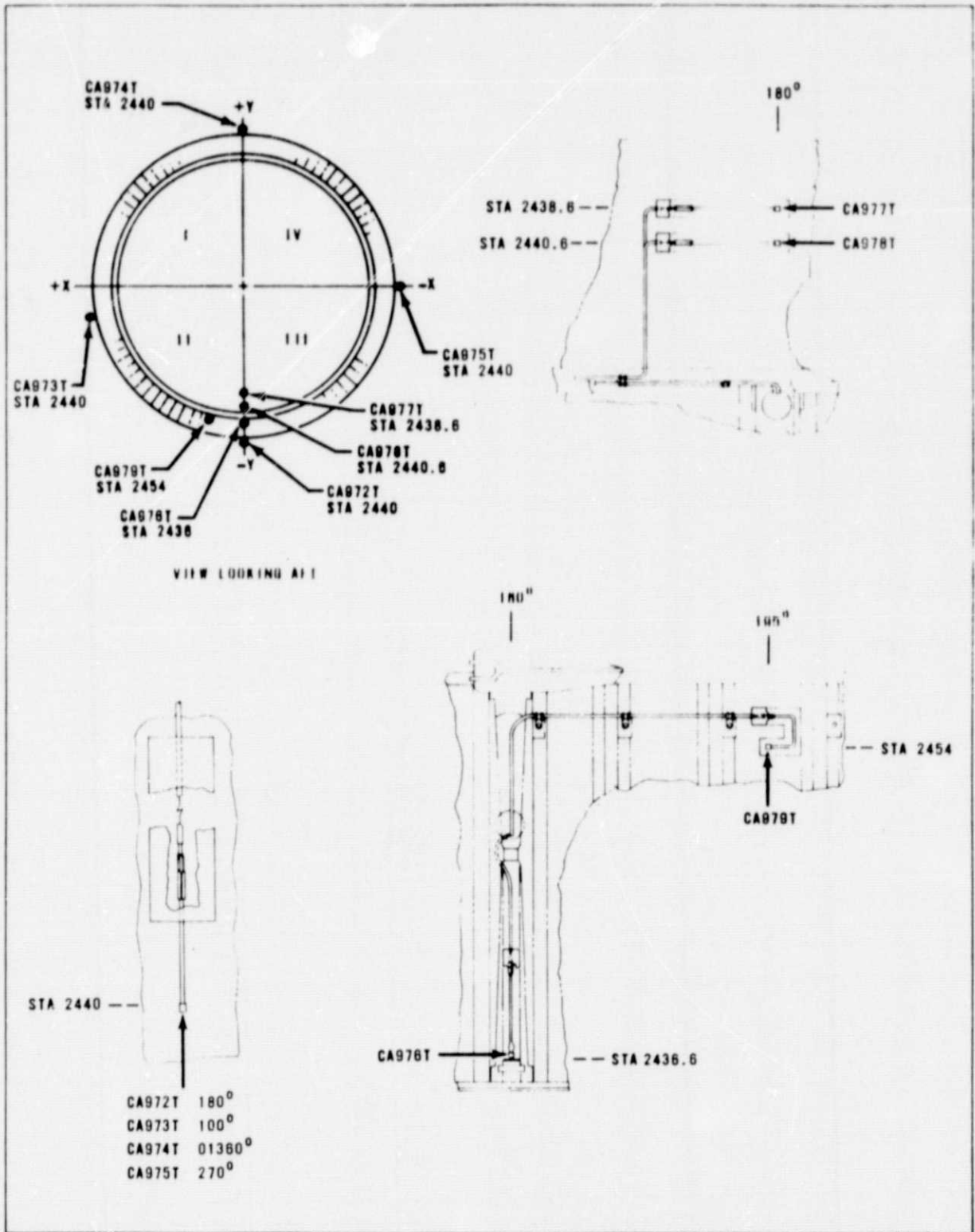

Figure 2D CENTAUR Stub Adapter Skin and Radiation Shield Temperatures

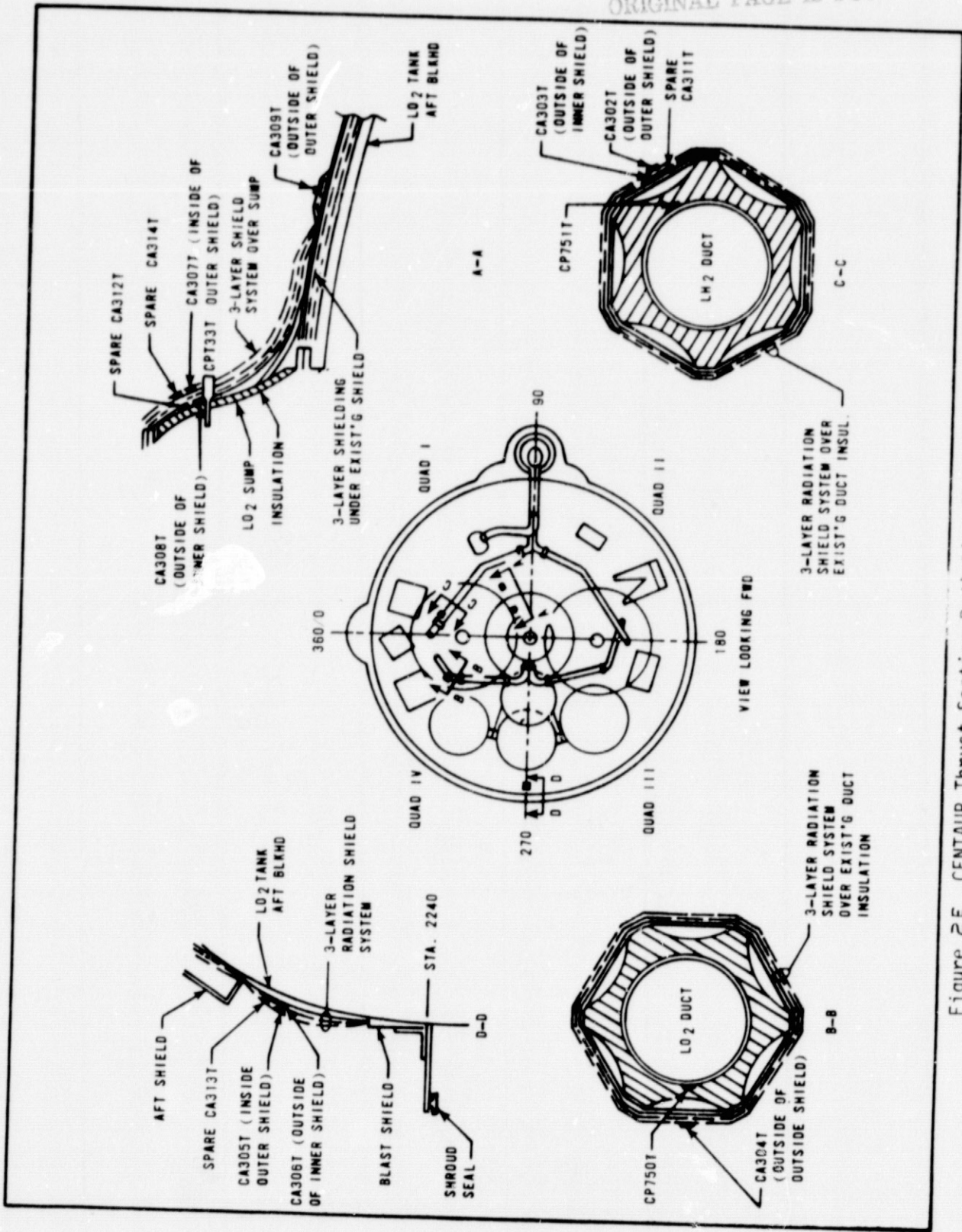

Figure 2E CENTAUR Thrust Section Radiation Shield Temperatures

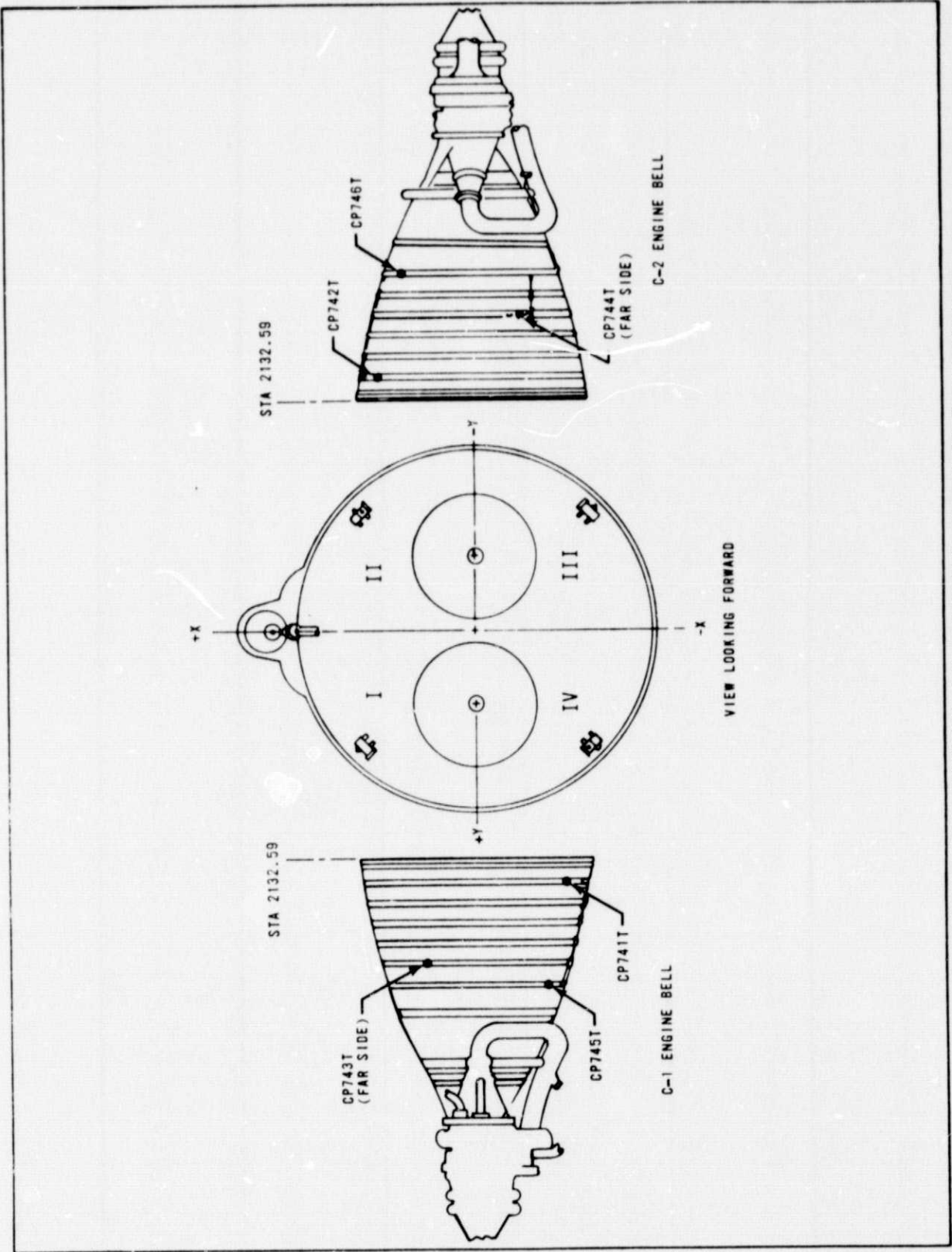

Figure 2F CENTAUR C-1 and C-2 Engine Bell Temperature

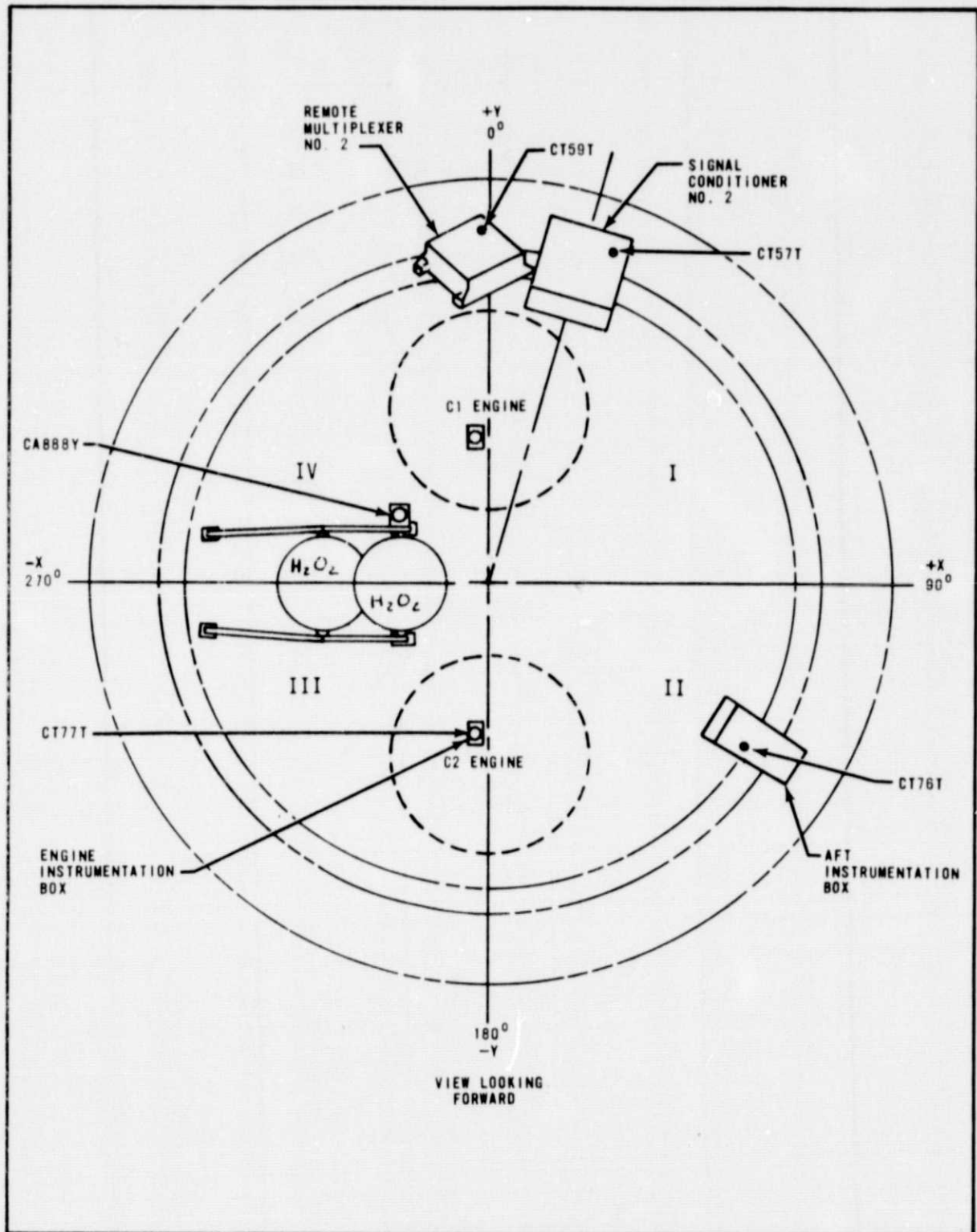

Figure 2H. CENTAUR Thrust Section Instrumentation Unit Installation

DISCUSSION OF RESULTS

Electronic Packages

The forward and aft end electronic package flight temperature ranges are summarized in table 2. The same table also lists the qualification limits of the packages and the thermal control technique used. The most common forms of thermal control were the use of white paint to help radiate the heat away from those packages which produce internal heat dissipation, and the use of aluminized enamel to help retain the heat for those packages that do not produce internal heat dissipation. As shown in table 2, all of the package temperature ranges were maintained within the qualification limits for the entire extended mission.

The packages on the forward end generally tended to increase in temperature throughout the mission in response to the maximum heating environment. An example of this trend for 3 selected electronic packages is shown in figure 3. The effectiveness of the thermal rolls in maintaining the temperatures at reasonable values is evident, even though the general trend is still increasing to the extent that the upper qualification temperature limits may have been reached after a few additional hours of coasting.

Another example of forward end electronic package heating is given in figure 4 for the three main vehicle batteries. These batteries can have an internal heat dissipation of up to 240 watts and as a result are somewhat independent of the space heating environment. This is evident in the figure which shows no clear effect of the thermal rolls on the battery temperatures. At about 5 hours into the flight the battery No. 1 voltage began to decrease and resulted in a greater load being shared by batteries No. 2 and No. 3. As a result the battery No. 2 and No. 3 temperatures increased and the battery No. 1 temperature decreased. Battery No. 2 could have reached its upper qualification limit (200°F) in about 3 additional hours of flight time.

The aft end package temperatures tended to decrease during the mission in response to the less than nominal aft end heating environment. An example of this trend for three selected aft end packages is shown in figure 5. For a minimum heating environment the package temperature decrease would have been slightly greater but the package temperatures would still have been well above their minimum qualification temperature limits.

TABLE 2

Electronic Package Thermal Performance Summary

Meas. No.	Description*	Qualification Limits of	Maximum Observed Temp. °F @ Hr.:Min.	Minimum Observed Temp. °F @ Hr.:Min.	Thermal Control Technique
CB1T	C-Band Transponder	-65 to 160	148 @ 8:34	72 @ 4:10	Painted White
CC202T	SCU Housing WEB	-76 to 140	132 @ 8:34	75 @ 0:14	Aluminized Enamel
CET108T	Main Battery No. 1	40 to 200	135 @ 5:00	86 @ Liftoff	White Painted Case
CET109T	Main Battery No. 2	40 to 200	152 @ 9:32	84 @ Liftoff	White Painted Case
CET110T	Main Battery No. 3	40 to 200	154 @ 9:32	84 @ Liftoff	White Painted Case
CI300T	IRU Skin Internal	40 to 130	117 @ 9:32	83 @ Liftoff	Painted White, Iridite Mount
CI316T	SEU Internal	40 to 130	122 @ 9:32	75 @ Liftoff	Painted White
CK30T	DCU Skin	-9 to 170	162 @ 8:23	88 @ 0:01	Painted White
CS811T	SIU Skin	-69 to 172	147 @ 8:34	75 @ Liftoff	White Housing, Aluminized Top and Bottom
CT56T	Signal Conditioner No. 1 (Forward)	-76 to 176	125 @ 7:41	65 @ 0:39	Aluminized Enamel
CT57T	Signal Conditioner No. 2 (Aft)	-76 to 176	108 @ 4:13	64 @ 9:32	Aluminized Enamel
CT58T	RMU No. 1	-22 to 176	104 @ 7:50	63 @ 2:24	{ 55% White Paint
CT59T	RMU No. 2	-22 to 176	84 @ 1:34	25 @ 9:24	{ 45% Aluminized Enamel
CT61T	S-Band Transmitter	-22 to 176	153 @ 7:46	77 @ Liftoff	Painted White
CT75T	Equipment Module Instrument Box	-65 to 165	102 @ 8:13	75 @ 0:43	{ 3-Layer Radiation Shield, Aluminized Box, Heaters
CT76T	Aft Bulkhead Instrument Box	-65 to 165	77 @ Liftoff	31 @ 8:41	Chromic Acid Anodize Chromic Acid Anodize
CT77T	C-2 Engine Instrument Box	-65 to 165	71 @ Liftoff	25 @ 9:32	
CU240T	C-1 Servo Positioner Housing	-50 to 160	66 @ Liftoff	-6 @ 7:47	
CU241T	C-2 Servo Positioner Housing	-50 to 160	84 @ 0:38	16 @ 8:25	

*Refer to figure 2B for instrumentation locations

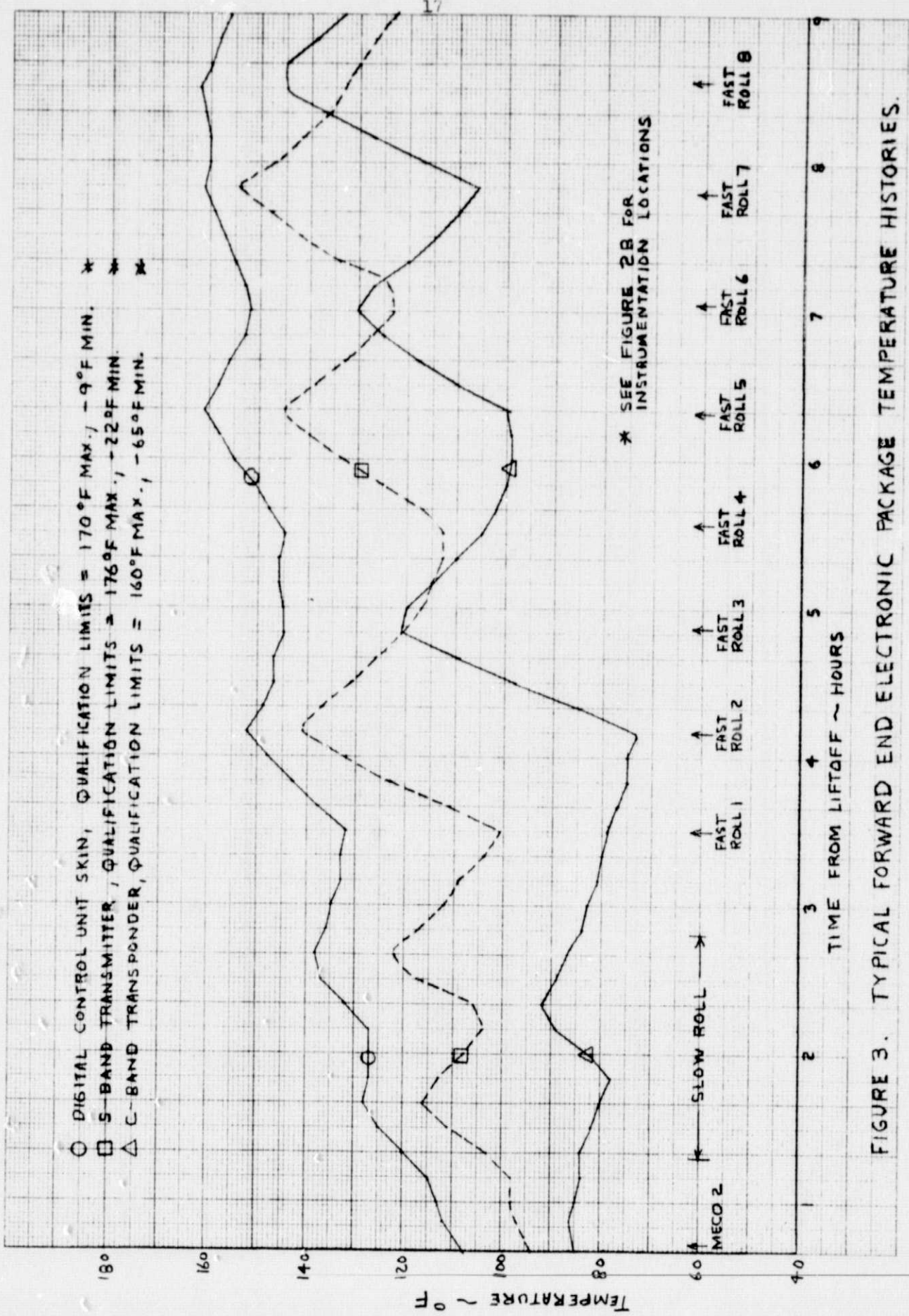

FIGURE 3. TYPICAL FORWARD END ELECTRONIC PACKAGE TEMPERATURE HISTORIES.

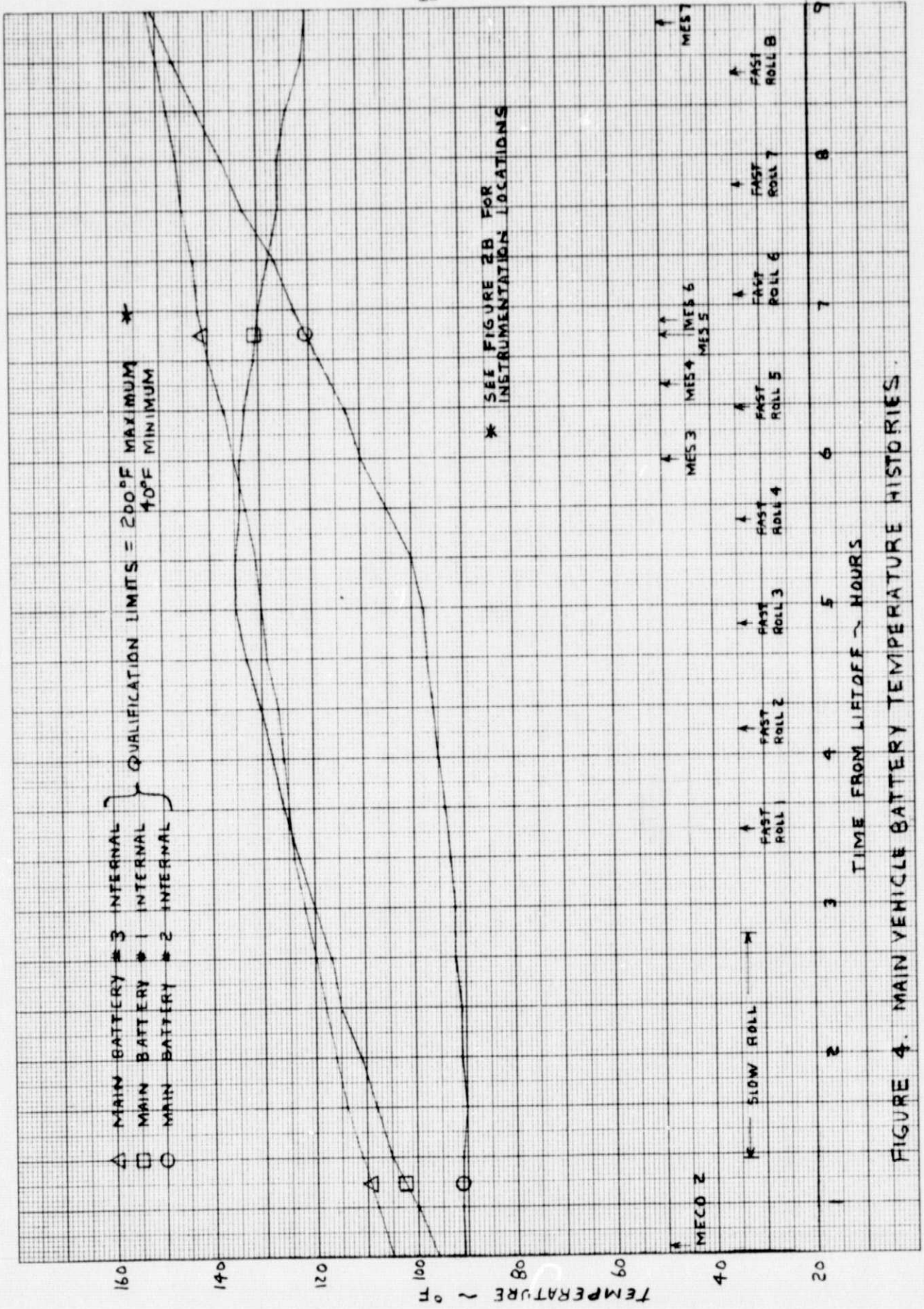

FIGURE 4. MAIN VEHICLE BATTERY TEMPERATURE HISTORIES.

REPRODUCIBILITY OF THE ORIGINAL PAGE IS POOR

- AFT BULKHEAD INSTRUMENTATION BOX. QUALIFICATION LIMITS = 165°F MAX., -65°F MIN.
- C-2 ENGINE INSTRUMENTATION BOX. QUALIFICATION LIMITS = 166°F MAX., -65°F MIN.
- △ C-1 SERVO POSITIONER HOUSING. QUALIFICATION LIMITS = 160°F MAX., -50°F MIN.

* SEE FIGURE 2H FOR INSTRUMENTATION LOCATION

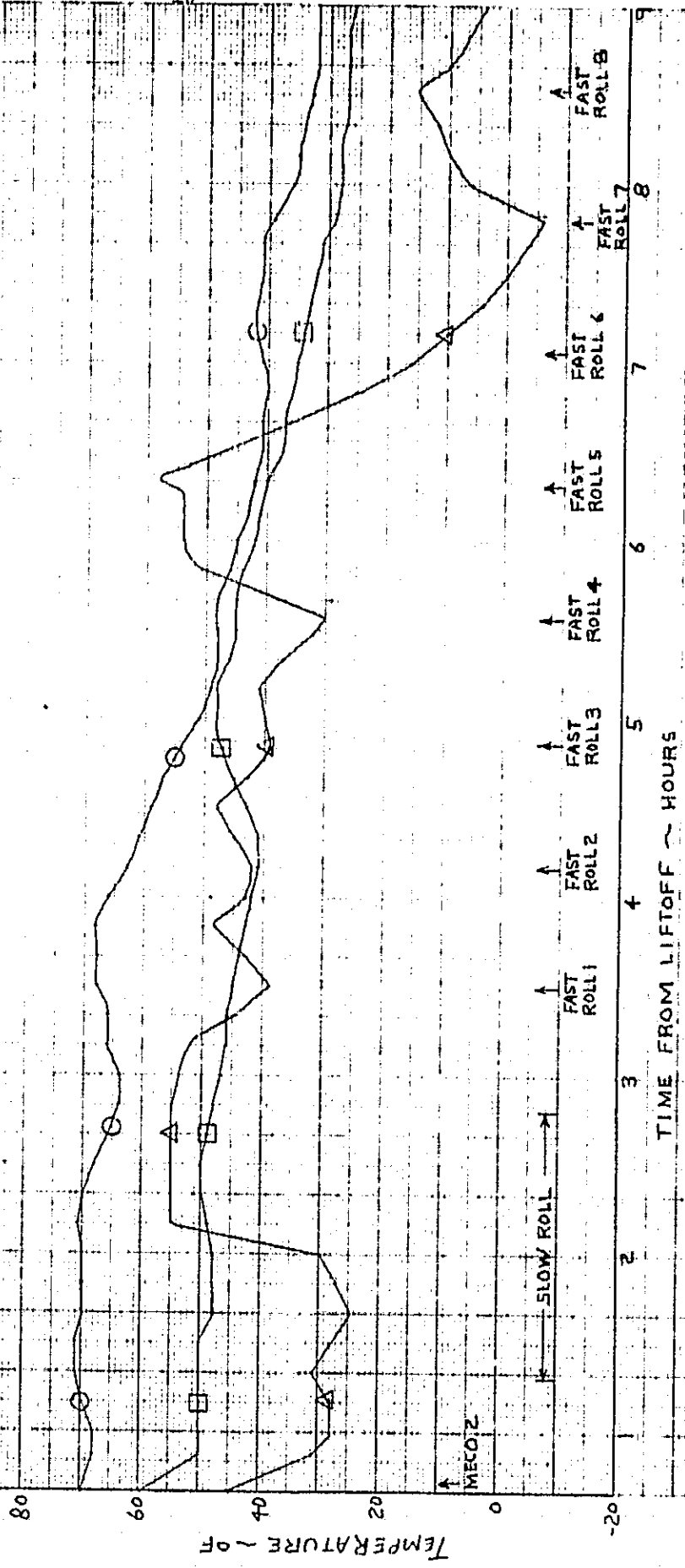

FIGURE 5. TYPICAL AFT END ELECTRONIC PACKAGE TEMPERATURE HISTORIES.

Stub Adapter

The Centaur stub adapter is a skin and stringer structural section that mates to the forward end of the tank as shown in figure 2C. For long space coast missions the adapter is constructed of titanium in order to reduce the heat conduction to the forward end of the LH₂ tank. The thermal conductivity of the titanium is about 1/25th that of the thermal conductivity of the standard aluminum stub adapter used for short duration missions. The outside of the stub adapter is also covered by a 0.020-inch fiberglass - .002-inch aluminum foil radiation shield composite to reduce the environmental heating to the adapter.

The flight temperature history at select locations of the stub adapter is shown in figure 6. As shown in this figure, the stub adapter steady state temperature gradient was established about 1-1/2 hours after liftoff. The heating and cooling of the radiation shield in response to the space environment, and the large temperature difference between the shielding and the adapter, shows that the shielding was effective in attenuating the solar heating to the adapter. As a result of this attenuation, the stub adapter temperature remained relatively constant throughout the duration of the extended mission.

Since the stub adapter is like a cylindrical fin attached to the forward ring of the LH₂ tank, the metallic conduction heat input to the LH₂ tank can be directly calculated. The calculated steady state conductive heat input is 225 BTU/Hr., well below the design goal of 500 BTU/Hr.

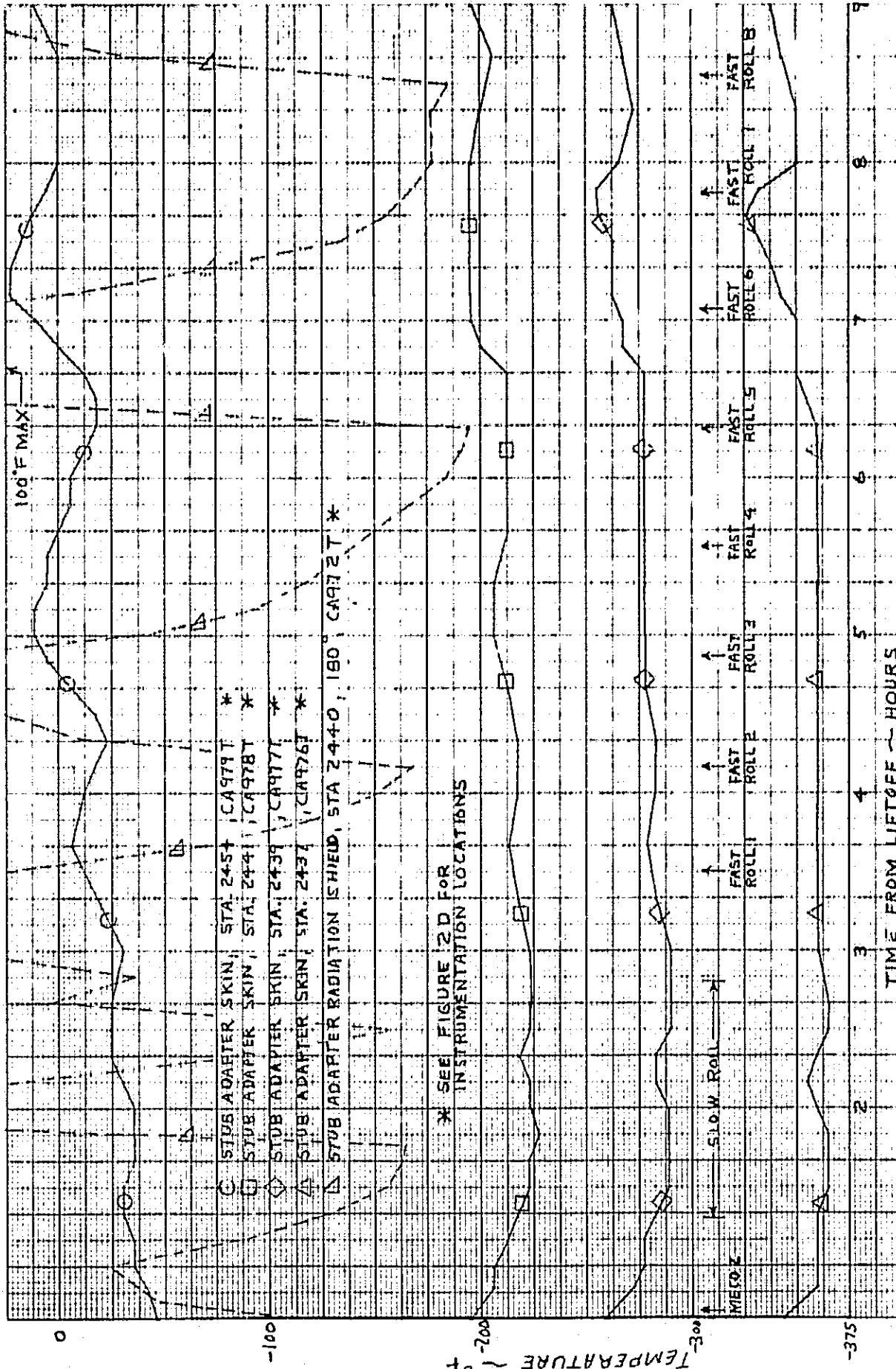

FIGURE 6. STUB ADAPTER TEMPERATURE HISTORY.

Forward Bulkhead and Equipment Module

Figure 7 shows an example of the temperature data of the 1.5-inch thick, 23 layer, forward bulkhead radiation shield insulation blanket. This insulation, which does not directly view the space environment, responds to radiation and residual gas convection from inside the stub adapter and the equipment module. As a result of this configuration, the temperature of the external layer of the radiation shielding closely follows the equipment module temperature behavior.

There is a considerable thermal lag in the insulation blanket, as shown by the temperature of the middle layer which comes on scale at about five hours after liftoff. This lag is the result of the conduction of residual gases that exist in the insulation blanket. As the residual gases are slowly evacuated the inner layers of the blanket warm up due to the decoupling of the insulation from the tank bulkhead surface. As the warming occurs, the radiation heat transfer to the tank increases and the conductive heat transfer through the residual gases decreases. Based on vacuum chamber test data of the insulation, the thermal lag observed during the extended mission is indicative of a residual gas pressure of 1×10^{-3} torr with a corresponding forward bulkhead heat flux of about 1.5 BTU/Hr.-Ft.². This heat flux is within the 2 BTU/Hr.-Ft.² design goal of the forward bulkhead insulation space performance.

The forward bulkhead skin temperature (located beneath the insulation blanket) history is shown in figure 8. This skin temperature increased from -400°R to -387°R during the 5-1/4-hour zero gravity coast, which indicates that liquid hydrogen was not present at this location. However, at other locations other tank instrumentation (liquid-vapor sensors, not discussed in this report) did indicate the presence of liquid, which accounts for the absorption of some of the heat input through the forward bulkhead insulation. Sufficient LH₂ did not migrate to the forward end of the tank during the zero gravity coast to reach the forward bulkhead skin temperature location.

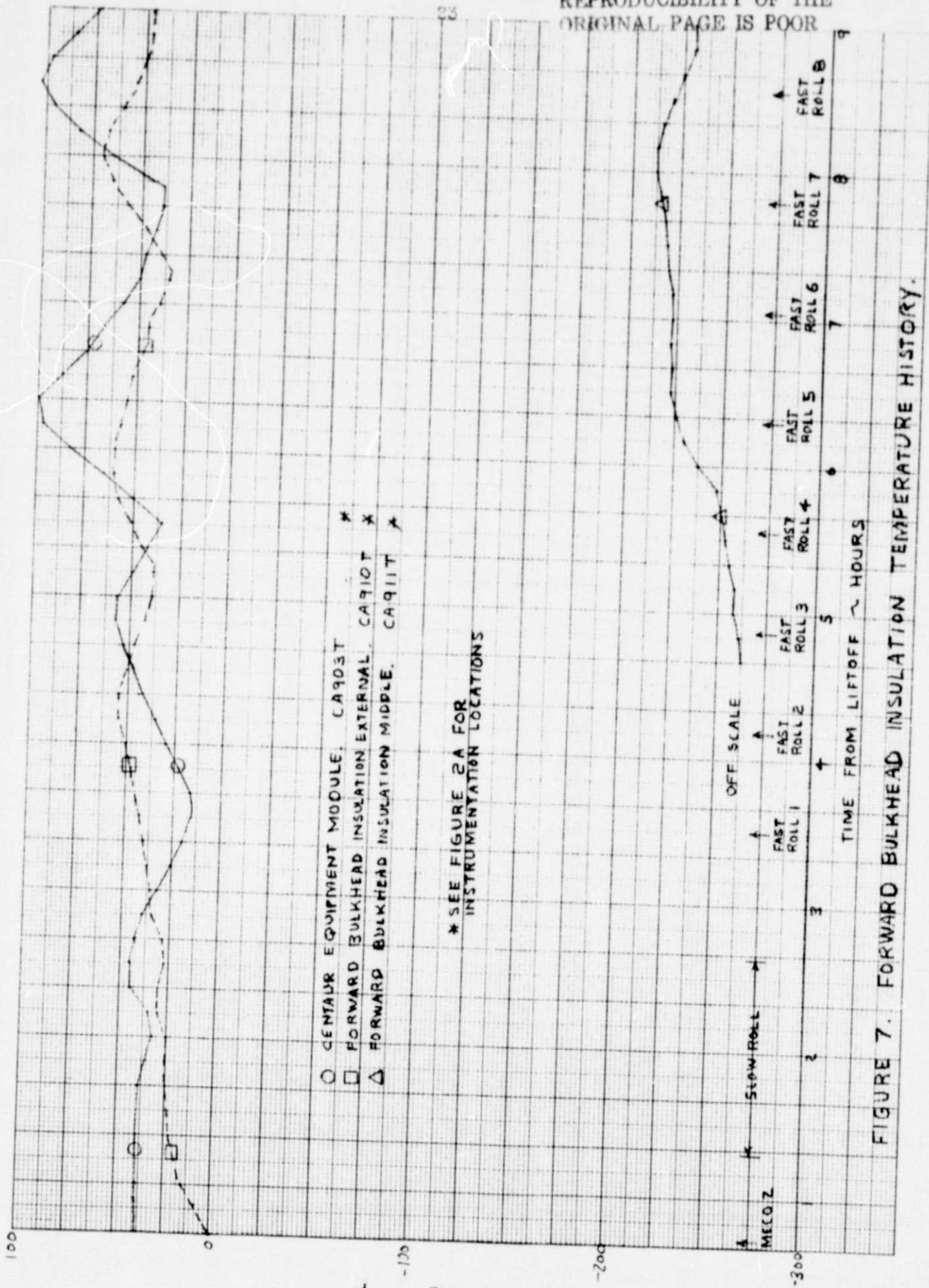

- CENTAUR EQUIPMENT MODULE. CA903T *
- FORWARD BULKHEAD INSULATION EXTERNAL. CA910T *
- △ FORWARD BULKHEAD INSULATION MIDDLE. CA911T *

* SEE FIGURE 2A FOR INSTRUMENTATION LOCATIONS

FIGURE 7. FORWARD BULKHEAD INSULATION TEMPERATURE HISTORY.

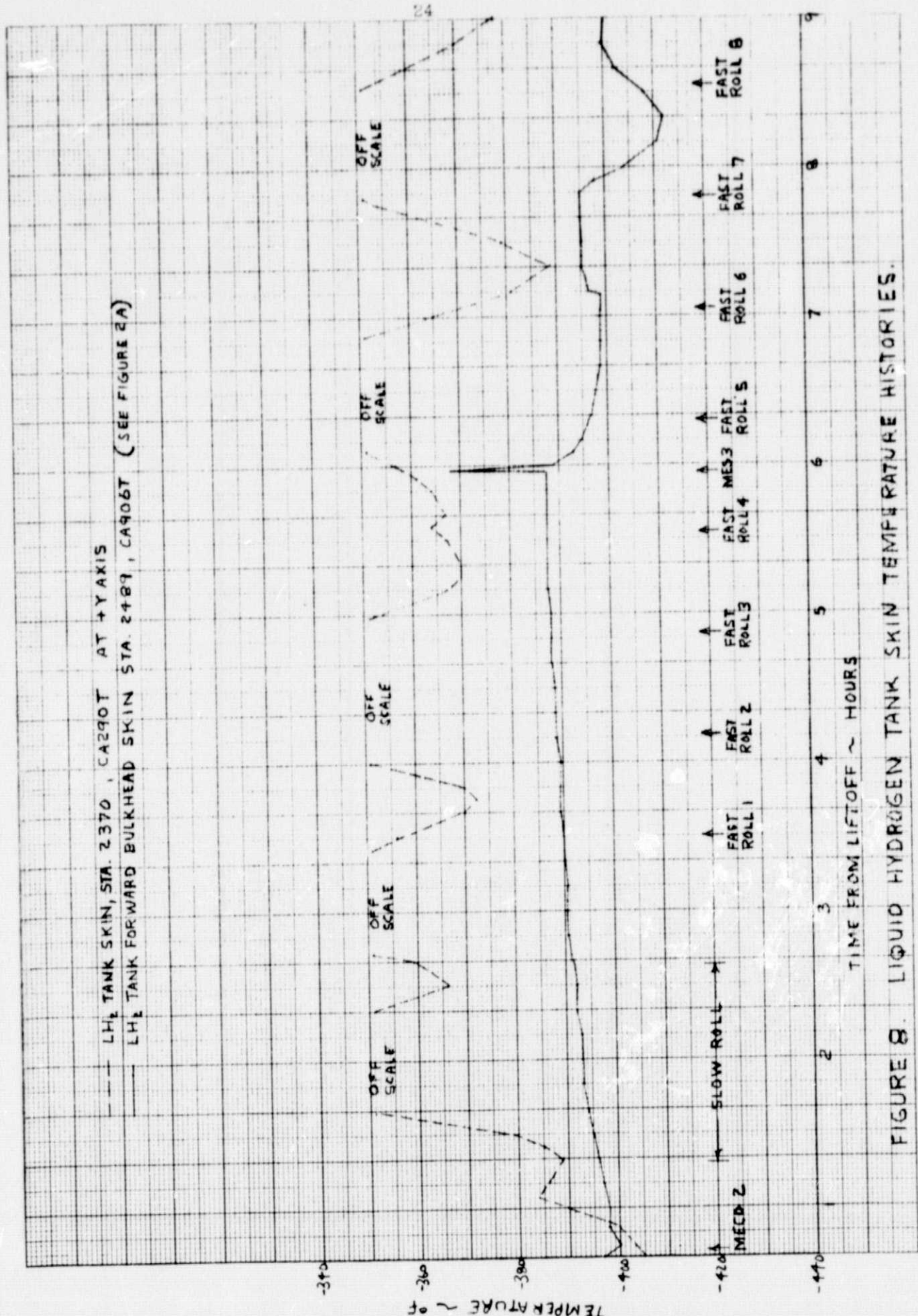

FIGURE 8. LIQUID HYDROGEN TANK SKIN TEMPERATURE HISTORIES.

Liquid Hydrogen Tank Aft Bulkhead Radiation Shielding

The hydrogen tank sidewall is thermally protected with a covering of three layer radiation shielding. An example of the thermal performance of this shielding during the extended mission is shown in figure 9. As shown in this figure, the radiation shield temperatures respond rapidly to the changes in the solar environment resulting from the roll maneuver. The sun position with respect to the tank sidewall is clearly seen by the large temperature excursions of the external radiation shield. The rapid temperature response, and the corresponding large thermal gradients, demonstrate that the shielding has achieved the evacuated conditions and thermal isolation required for good space performance.

An example of the LH₂ tank sidewall skin temperature response is shown in figure 8. The skin temperature also closely follows the thermal rolls. This temperature, together with the inner radiation shield temperature of figure 9, can be used to approximate the heat flux to the tank sidewall. This calculated heat flux is 0.3 BTU/Hr.-Ft² (average) and is well within the 1.0 BTU/Hr.-Ft² performance goal of the sidewall radiation shielding. The sidewall skin temperatures also indicate that no LH₂ is present along the sidewall during the zero gravity coasts.

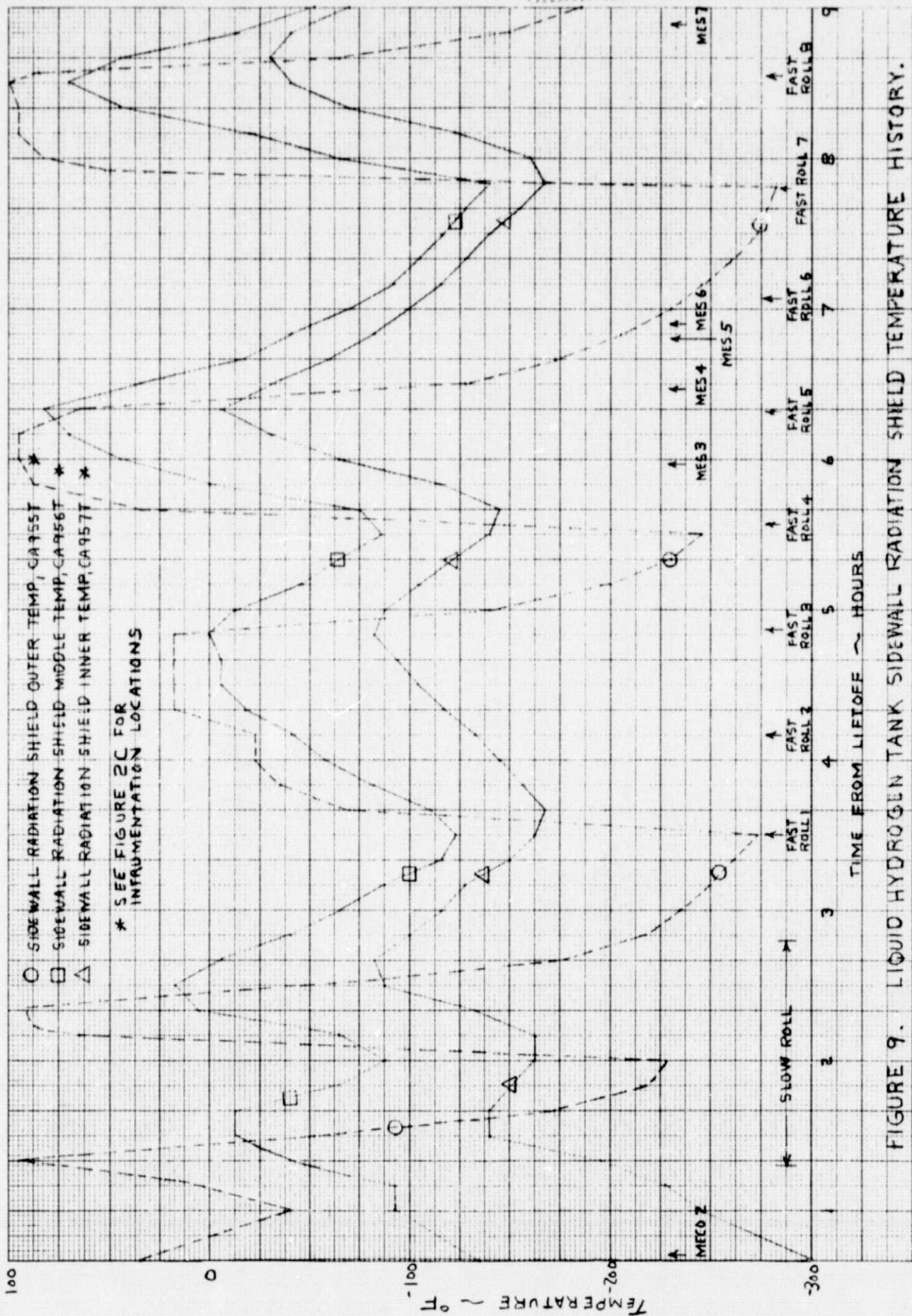

FIGURE 9. LIQUID HYDROGEN TANK SIDEWALL RADIATION SHIELD TEMPERATURE HISTORY.

Liquid Oxygen Tank Aft Bulkhead Radiation Shielding

The LO₂ tank aft bulkhead 3-layer radiation shield (using the same material as used on the LH₂ tank sidewall) system is sandwiched between a hard fixed nylon shield and the tank bracketry (see figure 2E). The thermal performance of this radiation shielding is shown in figure 10. The inner radiation shield temperature underneath the hard shield remained relatively constant at about -160°F. The high level of this temperature indicates that the shielding is evacuated and no cryogenic leakage flow exists under the shielding. Cryogenic leakage would increase the conduction between the tank and the shield and result in a very low shield temperature. The indicated heat flux, based on the inner shield temperature and LO₂ tank skin temperature, is 0.3 BTU/Hr.-Ft.² through the hard shield - 3-layer radiation shield composite. This heat flux is well below the performance goal of 1.0 BTU/Hr.-Ft.².

The thermal behavior of the LO₂ tank "peripheral" radiation shielding, which extends beyond the hard shield, is very similar to the LH₂ tank sidewall radiation shield temperature behavior. The large temperature excursions and gradients resulting from the thermal rolls indicate the good space performance of the shield systems.

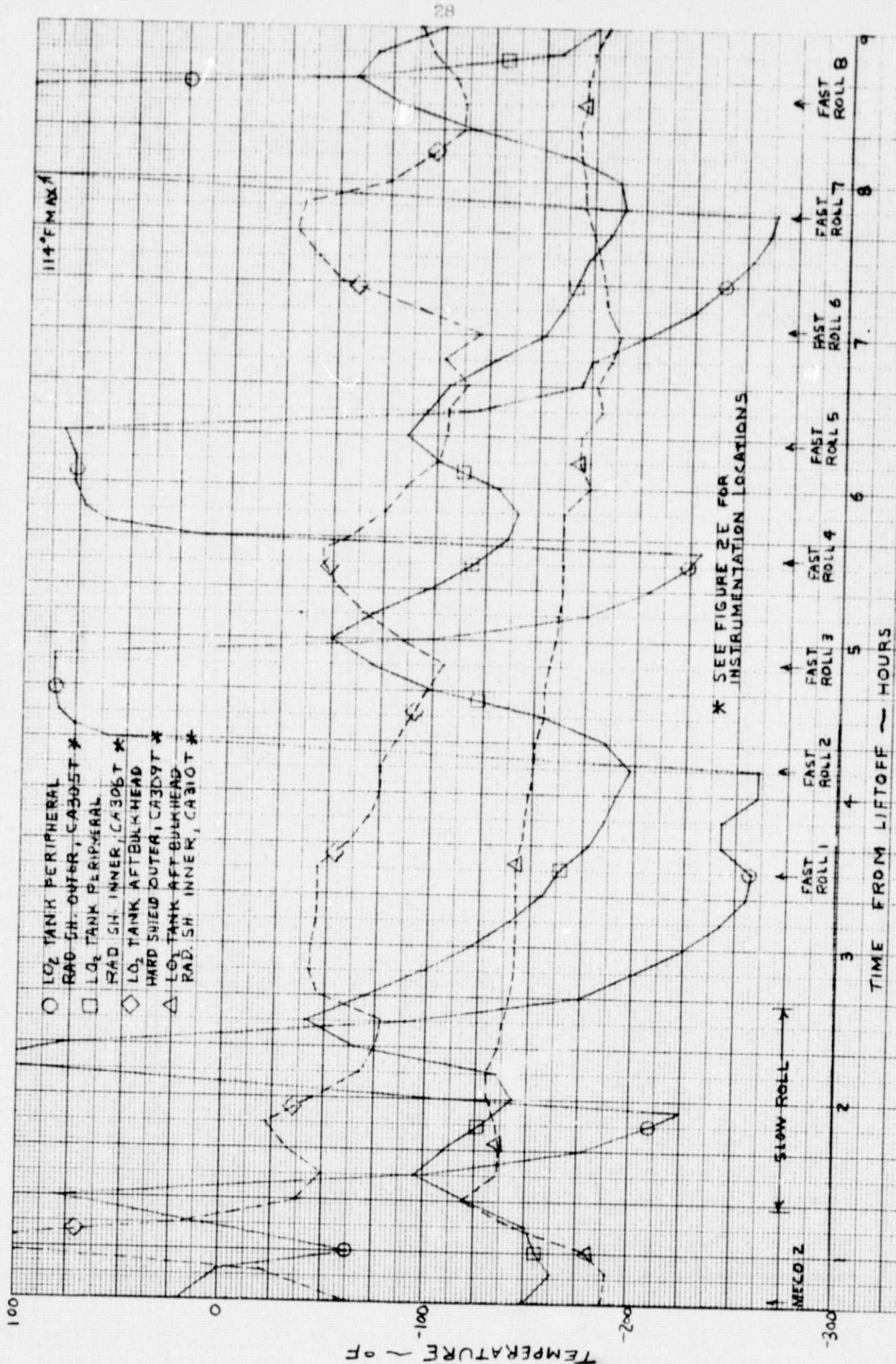

FIGURE 10. OXYGEN TANK AFT BULKHEAD RADIATION SHIELDING TEMPERATURE HISTORIES

Pneumatic and Vent Systems

The Centaur pneumatic panels mounted on the aft bulkhead of the LO₂ tank are iridited and separated from the LO₂ tank with fiberglass insulators in order to keep the panels warm during long coasts. The valve bodies are painted white, and the regulator covers are wrapped with aluminum tape, for thermal control.

For the extended mission, the two aft pneumatic panel temperature histories were nearly identical and ranged between 70°F and -30°F (the No. 2 pneumatic panel temperature history is shown in figure 11). The flight temperatures of the pneumatic panel components would also be within this range because of their larger thermal mass, and, hence, were well within their qualification limits (-100°F to 160°F for valves and -50°F to 125°F for regulators).

The helium storage bottle was wrapped with bonded aluminized mylar to keep the bottle warm during the coast in order to supply warm helium at an adequate pressure to the pneumatic and propulsion system components. The helium temperature history during the extended mission is shown in figure 11. As shown in this figure, the helium temperature decreases from 50°F to -50°F as helium is expelled for MES-3 pressurization but recovers rapidly after MES-3 as the result of heat soakback from the helium bottle. At the end of the mission, after most of the helium had been expelled, the helium temperature was 15°F, which is still sufficiently warm to have no adverse effect on those components that receive helium.

The LH₂ and LO₂ vent valves are normally open and require electric power (34 watts at 68°F) to be locked. In order to dissipate this energy during the extended mission the vent valve solenoids were painted white and thermal conductive grease was added between the solenoids and valve bodies. The resulting vent valve solenoid temperature histories are shown in figure 11. The LH₂ and LO₂ vent valve solenoids reached a maximum steady state value of 85°F and -10°F respectively. These temperatures were well below the 198°F qualification limit. The LH₂ vent valve solenoid temperature decreased nearly 100°F during the extensive tank venting during the 2-hour zero gravity coast prior to MES-7.

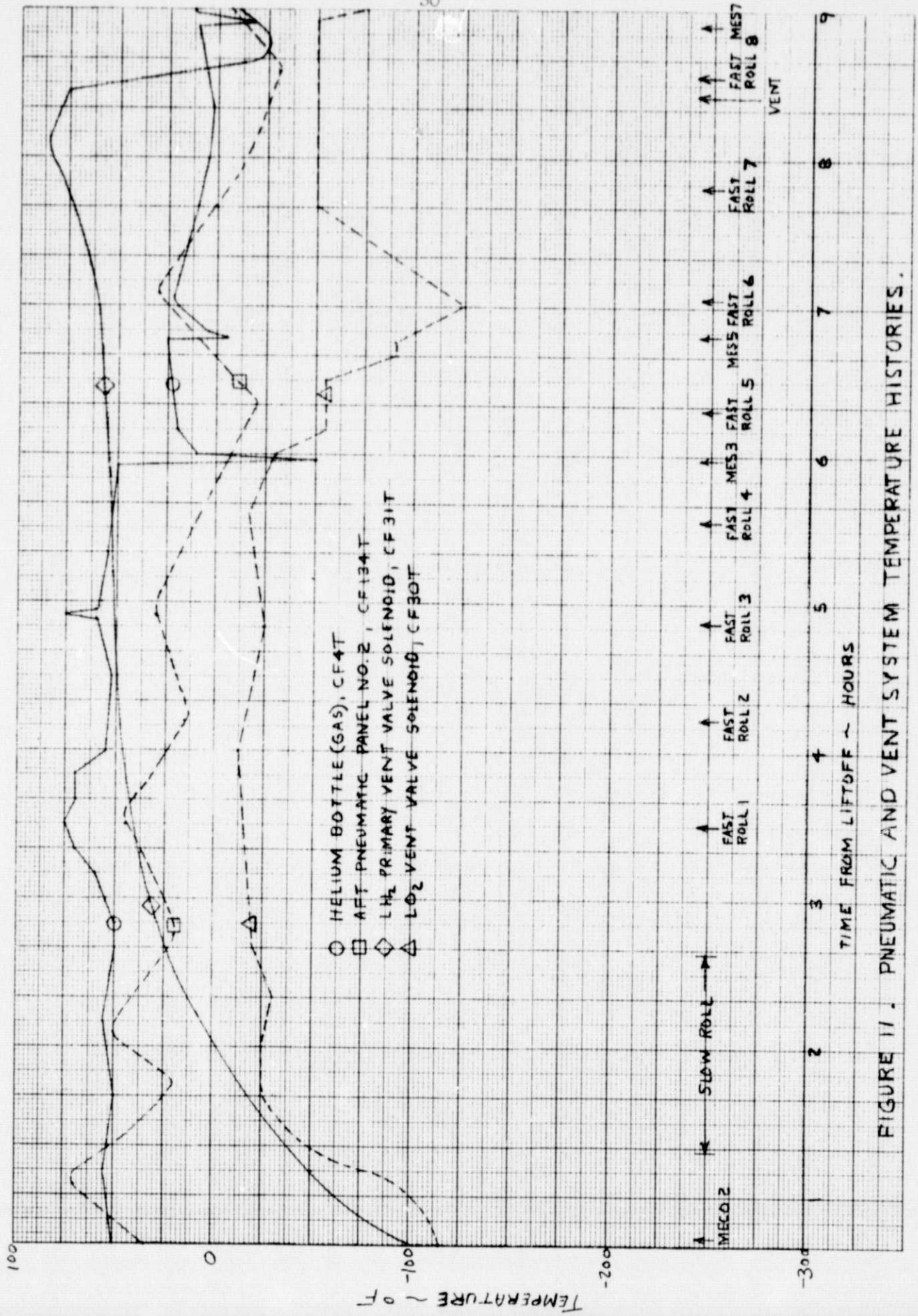

FIGURE 11. PNEUMATIC AND VENT SYSTEM TEMPERATURE HISTORIES.

Hydrogen Peroxide System

The H_2O_2 system temperature levels experienced during the extended mission are listed in table 3. The system components are categorized by the method of thermal control employed. The bottles are covered by double aluminized mylar and most of the H_2O_2 lines are heated. The unheated sections of the H_2O_2 system are thermally controlled by three-layer radiation shield boots. The valves and orifice receive heat soakback from large thermal masses. And the H_2O_2 engines are kept warm by periodic firing of the engines.

All of the H_2O_2 system temperatures were satisfactory throughout the extended mission. Most of the temperatures were maintained within narrow bands. However, some of the heated lines did warm considerably due to location and H_2O_2 usage. An example of this warming is shown in figure 12, which compares the temperature histories of the heated H_2O_2 lines at two different locations. Because of the redundant H_2O_2 flow line configuration, some lines contain stagnant H_2O_2 for long times. The quad 2 attitude control line temperature (CP151T), which contains stagnant H_2O_2 , exhibits much larger excursions than the quad 3 line which benefits from the frequent flow of H_2O_2 required for engine firings.

The warming firings of the H_2O_2 motors were designed to prevent the chambers from cooling down below the minimum operating temperature of $40^{\circ}F$ as the result of long periods (> 95 minutes) of inactivity. Four warming firings were accomplished during the extended mission (see table 1). As a result of these firings, the engine chamber temperatures were maintained well above the $40^{\circ}F$ minimum temperature during the extended mission. The minimum engine chamber temperature during the extended mission was $155^{\circ}F$.

TABLE 3
H₂O₂ SYSTEM THERMAL PERFORMANCE SUMMARY

Meas. No.	Description *	Category	Maximum Temp. OF @ Hr.-Min.	Minimum Temp. CF @ Hr.-Min.
CP93T	Attitude Control H ₂ O ₂ Bottle	H ₂ O ₂ Bottles	91°F @ 1:30	71°F @ 9:30
CP659T	Boost Pump H ₂ O ₂ Bottle	"	91°F @ 1:30	72°F @ 9:30
CP150T	Quad 1 A/C Line	Heated Full Lines	150°F @ 7:45	62°F @ 4:53
CP151T	Quad 2 A/C Line	"	190°F @ 3:30	75°F During Ascent
CP152T	Quad 2/3 A/C Line	"	137°F @ 4:53	71°F @ 7:48
CP153T	Quad 3 A/C Line	"	118°F @ 2:12	70°F @ 9:22
CP154T	Quad 4 A/C Line	"	112°F @ 2:25	76°F During Ascent
CP155T	Quad 1/4 A/C Line	"	137°F @ 1:36	62°F @ 9:30
CP756T	H ₂ O ₂ Crossover Line	"	95°F @ 1:10	81°F @ 9:16
CP831T	Line Between Feed Valves	"	150°F @ 1:22	81°F During Ascent
CP156T	Quad 1 H ₂ O ₂ Firing	Shielded Empty Lines	130°F @ 1:45	58°F @ 9:30
CP832T	H ₂ O ₂ Vent Line No. 1	"	90°F @ 0:55	45°F @ 5:58
CP157T	Quad 2 B/P H ₂ O ₂ Line	Heated Empty Lines	180°F @ 3:10	45°F During Ascent
CP158T	Quad 3 B/P H ₂ O ₂ Line	"	130°F @ 4:53	60°F During Ascent
CP159T	Quad 4 B/P H ₂ O ₂ Line	"	190°F @ 8:35	65°F During Ascent
CP710T	LH ₂ B/P Orifice Holder	Valves, Orifices	193°F @ 1:30	71°F During Ascent
CP711T	LO ₂ B/P Orifice Holder	"	140°F @ 1:20	65°F During Ascent
CP834T	B/P Feed Valve No. 2	"	110°F @ 0:50	70°F @ 8:00
CP361T	LH ₂ B/P Line Near Orifice	Unheated Empty Lines	260°F @ 0:58	60°F During Ascent
CP714T	LO ₂ B/P Supply Line	"	165°F @ 0:43	25°F During Ascent
CP833T	LH ₂ B/P Inlet Line	"	160°F @ 1:15	67°F During Ascent
CP148T	Y1 Chamber Surface	H ₂ O ₂ Engine	N/A	50°F During Ascent
CP149T	Y4 Chamber Surface	"	N/A	59°F "
CP375T	P3 Chamber Surface	"	N/A	50°F "
CP376T	P4 Chamber Surface	"	N/A	59°F "
CP691T	S4A Chamber Surface	"	N/A	59°F "
CP693T	S2A Chamber Surface	"	N/A	50°F "
CP836T	S4B Chamber Surface	"	N/A	59°F "
CP837T	S2B Chamber Surface	"	N/A	50°F "

* The H₂O₂ system instrumentation locations are shown in figure 2G.

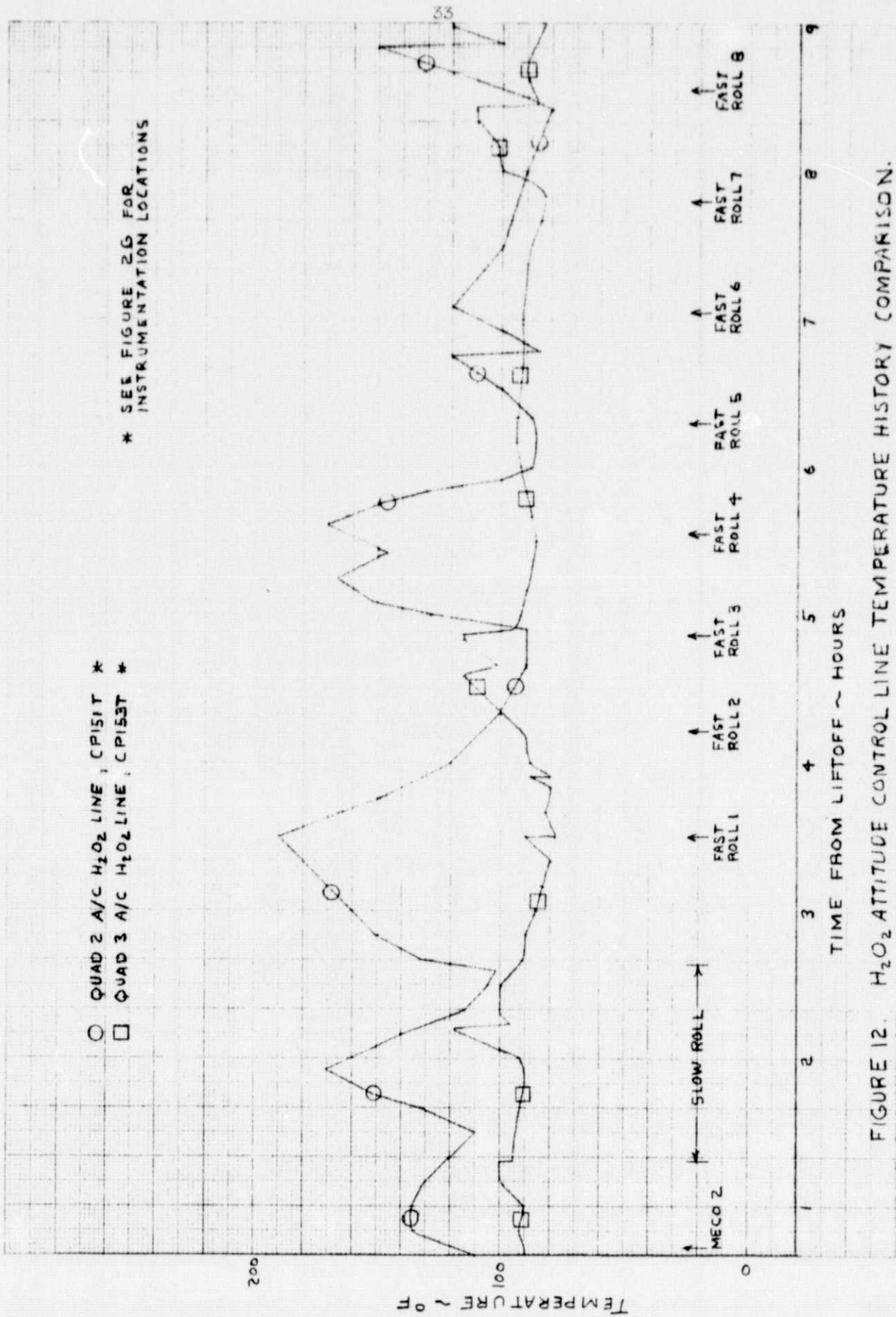

FIGURE 12. H₂O₂ ATTITUDE CONTROL LINE TEMPERATURE HISTORY COMPARISON.

Hydraulic System

The hydraulic system components were covered with three-layer radiation shielding except for the manifold and recirculation motor housing. The unshielded manifold contains a controlling thermostat that activates the recirculation motor if the temperature falls below 10°F.

Table 4 presents the hydraulic system temperatures at the beginning of each engine start sequence. As shown in the table, the temperatures of the shielded components were maintained between 40°F and 90°F. The coldest temperature experienced by the unshielded components of the hydraulic system was 15°F for the C-2 manifold at the start of the seventh fast roll. This temperature was not low enough to produce a recirculation motor activation. The combination of the thermal rolls and the radiation shielding were sufficient to maintain the hydraulic system well within its -30°F to 275°F qualification limits.

TABLE 4

HYDRAULIC SYSTEM THERMAL PERFORMANCE SUMMARY

Meas. No.	Location	Flight Temperature - OF								
		Liftoff	MES-1	MES-2	MECO-2	MES-3	MES-4	MES-5	MES-6	MES-7
CH2T	C-1 Hyd Pwr Pack *	66	64	86	130	53	58	58	60	60
CH4T	C-2 Hyd Pwr Pack *	69	69	87	144	65	61	63	61	43
CH5T	C-1 Hyd Manifold	69	65	70	160	80	55	44	44	41
CH6T	C-2 Hyd Manifold	60	56	75	170	30	29	35	39	55
CH9T	C-1 Recirc. Motor Hsg	63	57	74	70	58	50	46	49	36
CH10T	C-2 Recirc. Motor Hsg	53	53	78	92	53	46	59	61	50
CH33T	C-1 Yaw Accu Body *	85	81	78	136	75	64	59	52	47
CH36T	C-2 Pitch Accu Body *	87	84	90	145	70	63	59	57	49
	* Shielded									

Propulsion and Propellant Feed Systems

The major parameters affecting the main engine start characteristics after a space coast are the engine turbopump and propellant feed temperatures. These temperatures determine the cooldown duration and the corresponding propellant consumption required to thermally condition the engines prior to engine start. The warmer the temperatures, the longer the required cooldown.

The propellant duct insulation configuration is shown in figure 2E. For the extended mission, the standard foam insulation of the LH₂ and the LO₂ propellant ducts was covered with three layer radiation shielding with dacron net separators in order to limit the duct temperature increases during the 5-1/4-hour coast.

The LH₂ and LO₂ propellant duct temperature histories during the extended mission are shown in figures 13 and 14 respectively. The maximum duct temperatures at the end of the 5-1/4-coast were -94°F for the LH₂ duct and -200°F for the LO₂ duct. The LO₂ duct radiation shielding, which got as warm as 260°F from H₂O₂ engine exhaust heating prior to MES-3, performed satisfactorily in limiting the duct temperatures.

The main engine systems were retained in the standard configuration used on previous Centaur missions and did not receive any thermal control changes for the extended mission. The engine components, however, did benefit from the thermal rolls as shown in figures 15 and 16. The LO₂ and LH₂ engine turbopump temperatures (see figure 15) at the end of the 5-1/4-hour coast were -55°F and -110°F respectively. These temperatures, together with the propellant duct temperatures, were well within the range of previous engine test experience.

The engine bell temperatures, as shown in figure 16, reached a local maximum temperature of 260°F, and a weighted average maximum temperature of 150°F, during the 5-1/4-hour coast. The temperatures of the engine bells (the bells are 30% of the engine weight) are part of an engine requirement to maintain the weighted average engine temperature below 110°F. The maximum weighted average engine temperature was about 90°F for the C-1 engine at the end of the 5-1/4-hour coast. The thermal rolls prevented the various engine components from getting too warm. The maximum engine component temperatures experienced during the extended mission are listed in Table 5. Most of the maximum temperatures were obtained near the end of the 5-1/4-hour coast, as expected.

TABLE 5
 MAIN ENGINE SYSTEM THERMAL PERFORMANCE SUMMARY

<u>Measurement</u>	<u>Component</u>	<u>Maximum Temperature/Time from Liftoff</u>
CP741T	C-1 Engine Bell Outboard, S518	220°F @ 4:52
CP742T	C-2 Engine Bell Outboard, S518	205°F @ 5:35
CP743T	C-1 Engine Bell Inboard, S507	230°F @ 3:30
CP744T	C-2 Engine Bell Inboard, S507	70°F @ Liftoff
CP745T	C-1 Engine Bell Outboard, S500	240°F @ 4:52
CP746T	C-2 Engine Bell Outboard, S500	260°F @ 5:35
CP752T	C-1 LH ₂ Pump Discharge Line	70°F @ 5:58
CP753T	C-1 LH ₂ Pump Housing Second Stage	-50°F @ 5:58
CP754T	C-1 LH ₂ Jacket Inlet	70°F @ 8:35
CP63T	C-1 Thrust Chamber	70°F @ 5:58
CP98T	C-2 Thrust Chamber	50°F @ Liftoff
CP122T	C-1 Engine Fuel Pump	-110°F @ 5:58
CP123T	C-2 Engine Fuel Pump	-110°F @ 5:58
CP124T	C-1 Engine LOX Pump	-60°F @ 5:58
CP125T	C-2 Engine LOX Pump	-40°F @ 5:58
CP828T	C-2 Engine Turbopump Surface	-60°F @ 5:35
CP829T	C-2 Engine Turbopump Shield	210°F @ 6:50

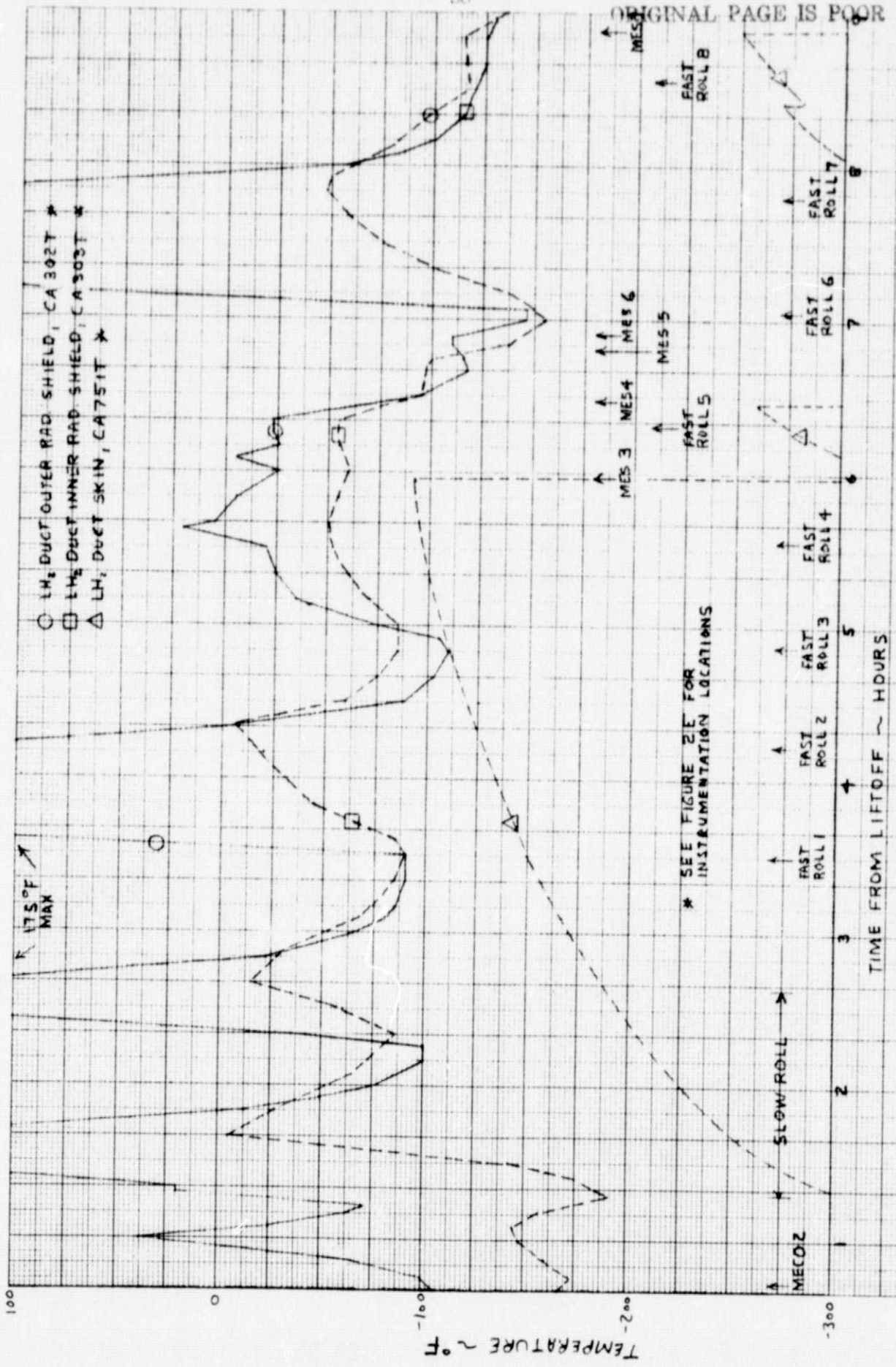

FIGURE 13. LIQUID HYDROGEN DUCT TEMPERATURE HISTORY.

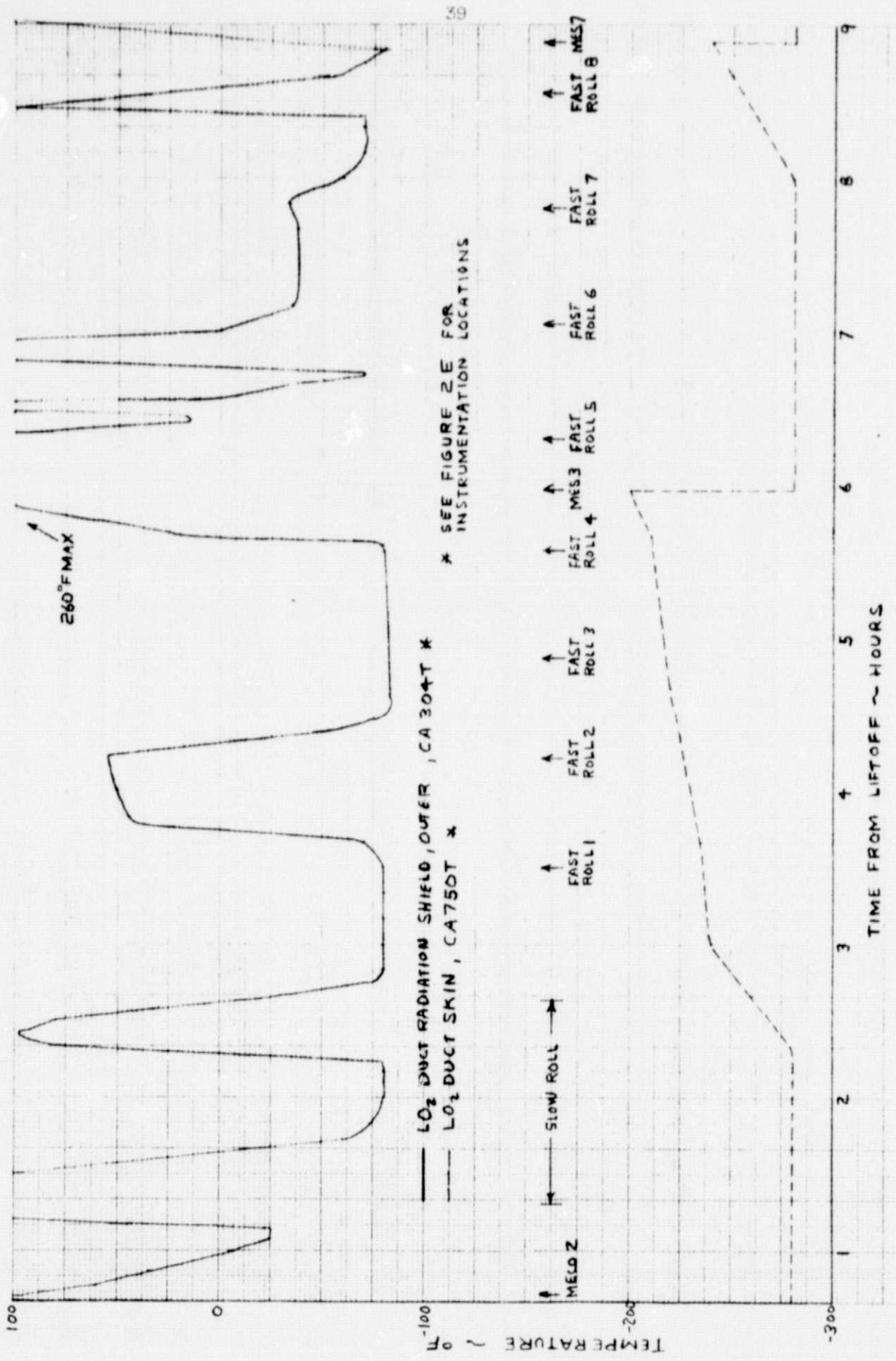

FIGURE 14. LIQUID OXYGEN DUCT TEMPERATURE HISTORY

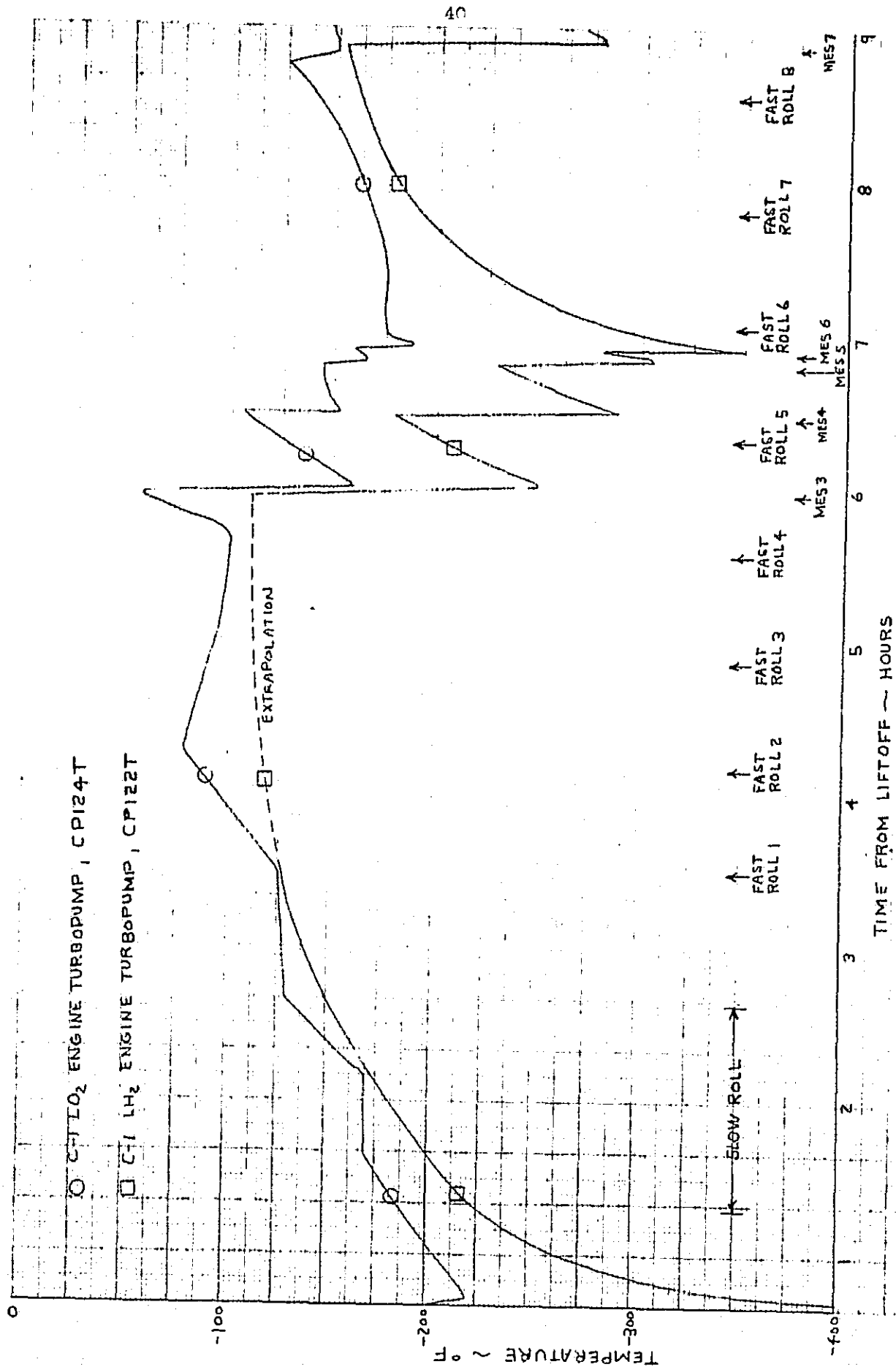

FIGURE 15. ENGINE TURBOPUMP TEMPERATURE HISTORIES.

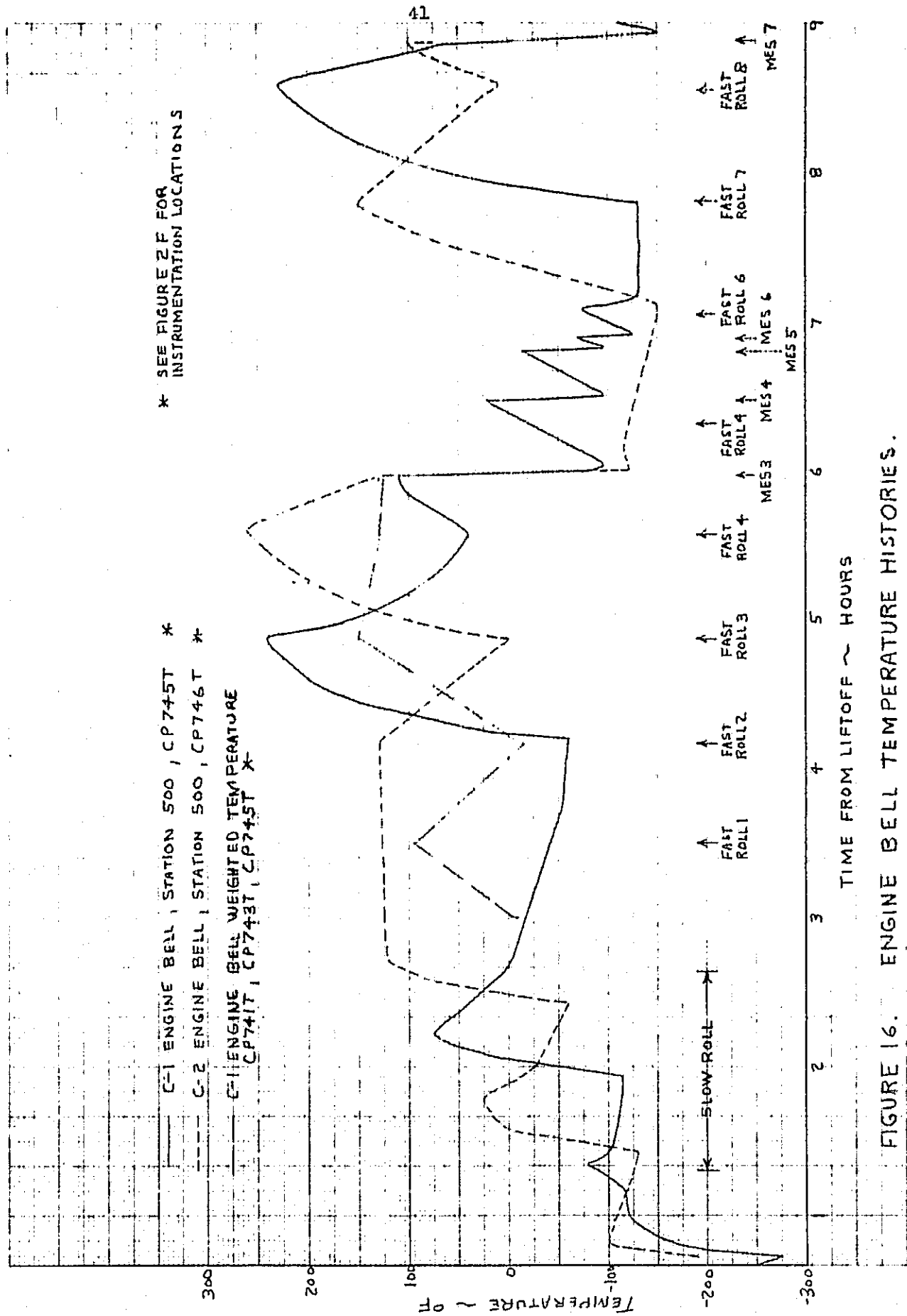

FIGURE 16. ENGINE BELL TEMPERATURE HISTORIES.

Propellant Tank Pressures

The propellant tank pressure histories during the extended mission are shown in figures 17A and 17B. During the 5-1/4-hour zero gravity coast the tank pressures increased at a low rate, indicating the overall effectiveness of the vehicle thermal control systems. The LO₂ tank average pressure rise rate was 0.95 psi/hr., and the LH₂ tank average pressure rise rate was 1.47 psi/hr. These pressure rise rates were very close to the rates expected for thermodynamic equilibrium conditions assuming that all of the tank heat inputs going into the liquid.

The total heating rates are estimated to be 1400 BTU/Hr. and 2100 BTU/Hr. for the LO₂ tank and LH₂ tank respectively. These heating rates were sufficiently low to enable the Centaur to accomplish the 5-1/4-hour coast without requiring a venting of either tank. The tank pressures at the end of the 5-1/4-hour coast were 32.8 psia for the LO₂ tank and 22.3 psia for the LH₂ tank. These pressures were well below the vent initiation pressures of 45.0 psia for the LO₂ tank and 27.6 psia for the LH₂ tank.

By the start of the two-hour zero gravity coast (after MECO-6) the liquid levels in the propellant tanks had been reduced considerably. With less liquid to absorb the tank heat inputs the pressure rise rates increased significantly to 1.2 psi/hr. for the LO₂ tank and 2.8 psi/hr. for the LH₂ tank. At about 1-1/2 hours into the 2-hour coast (8 hours and 25 minutes after liftoff) the LH₂ tank pressure reached the vent initiation pressure resulting in a propellant settling (collection) period of 150 seconds followed by a venting period of 40 seconds. During the venting period the tanks were vented down to the vent termination pressures of 35.0 psia for the LO₂ tank, and 23.5 psia for the LH₂ tank.

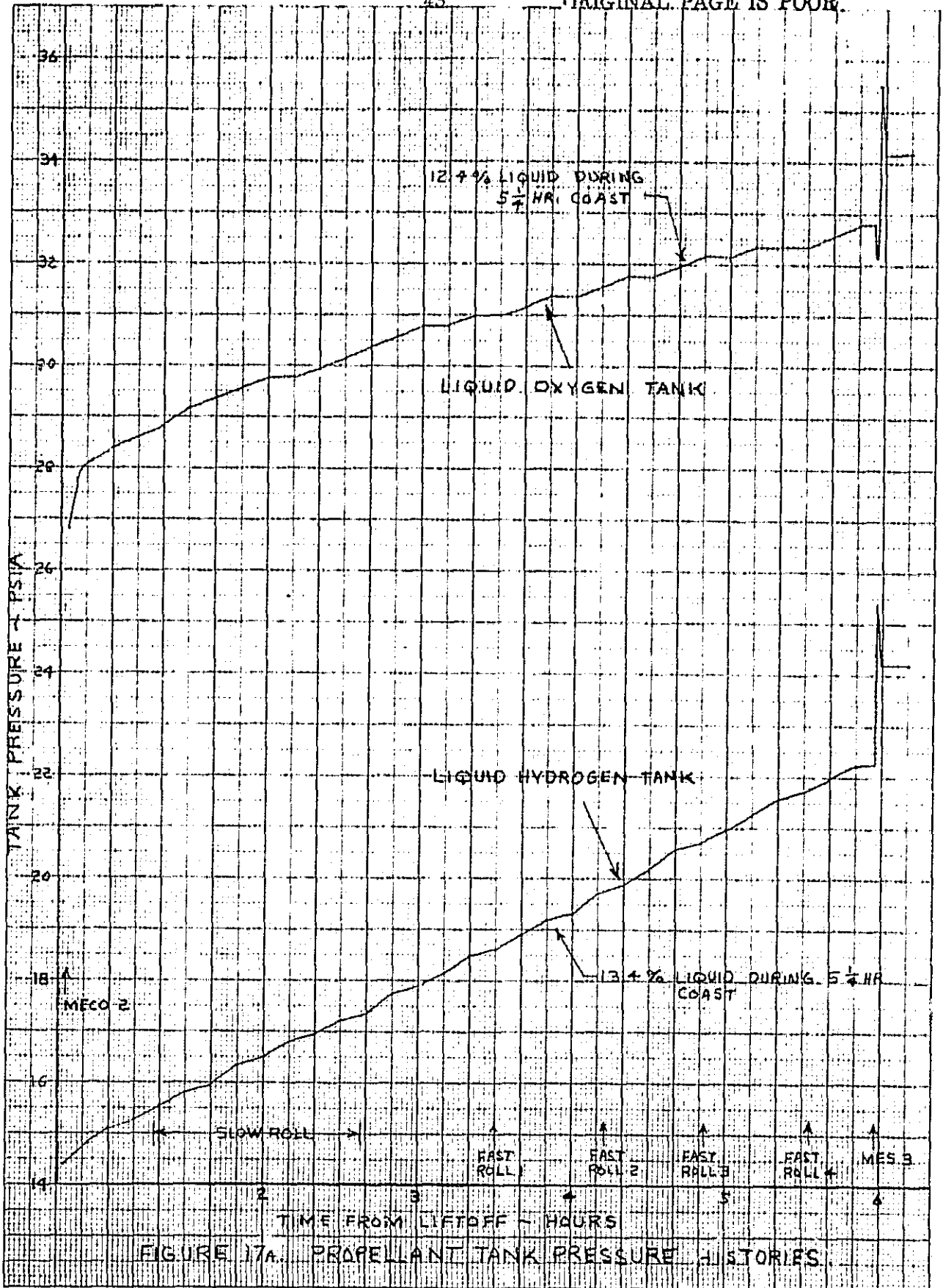

FIGURE 17A. PROPELLANT TANK PRESSURE HISTORIES.

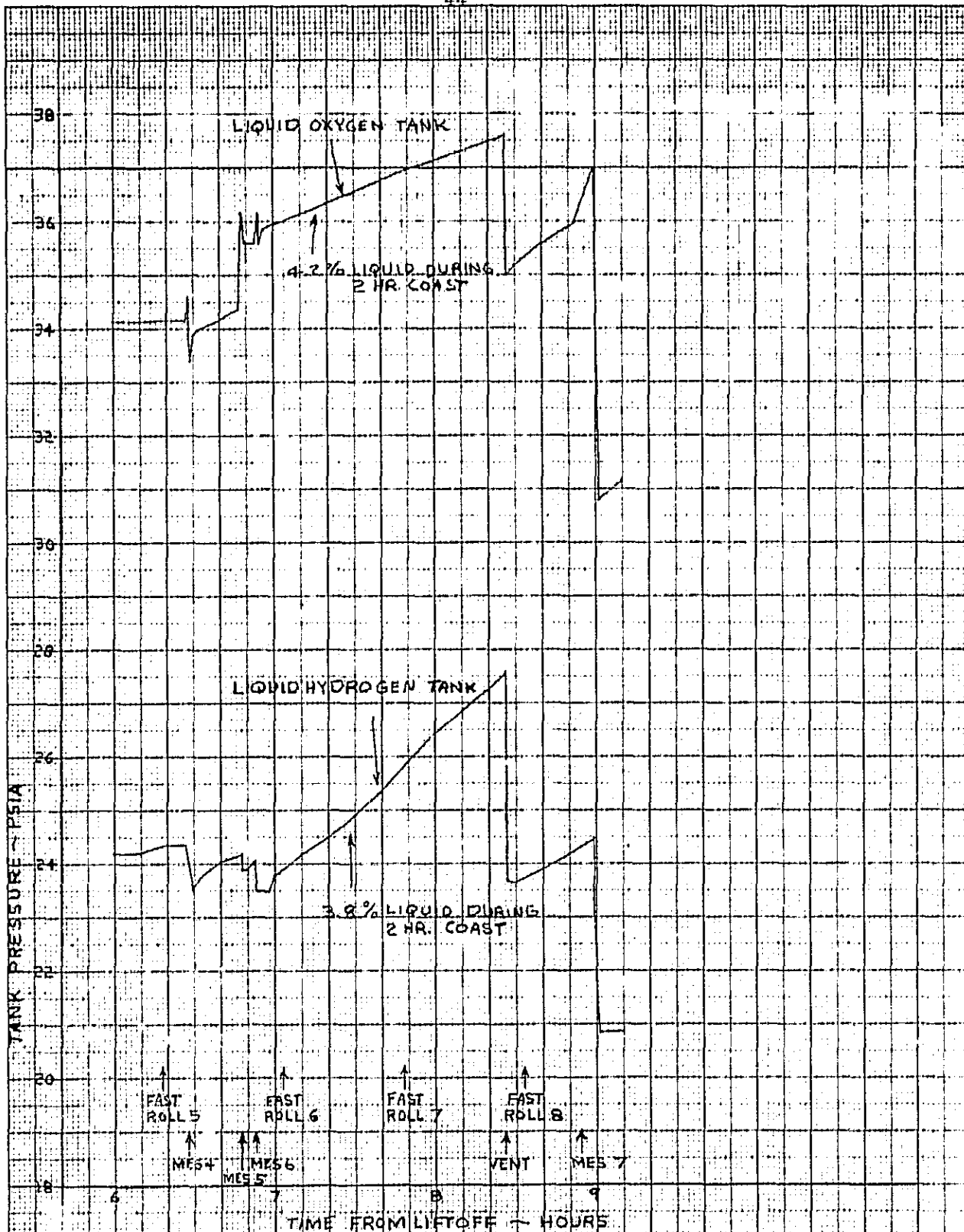

FIGURE 17B. PROPELLANT TANK PRESSURE HISTORIES (CONTINUED)

CONCLUSIONS

The TC-5 extended mission objective of demonstrating and verifying the Centaur synchronous (5-1/4-hour) coast capability was successfully accomplished. The results of the TC-5 extended mission showed that the thermal control techniques selected for Centaur long space coast operation were satisfactory. All of the Centaur system and component temperatures remained within their qualification limits for the entire 8-hour and 22-minute duration of the extended mission. And the trend of the temperature histories indicated that considerably longer space coasts were possible for most of the Centaur components.

Both of the thermal roll maneuvers used during the extended mission were satisfactory. Either the fast roll, or the slow roll, maneuver results in uniform Centaur vehicle heating, and either maneuver is acceptable for future mission applications.

No significant Centaur component temperature anomalies or discrepancies were observed during the entire extended mission. In addition the propellant tank heating rates, and corresponding tank pressure rise rates, were sufficiently low to enable the Centaur to accomplish the 5-1/4-hour zero gravity coast without requiring a venting of either tank.