

General Disclaimer

One or more of the Following Statements may affect this Document

- This document has been reproduced from the best copy furnished by the organizational source. It is being released in the interest of making available as much information as possible.
- This document may contain data, which exceeds the sheet parameters. It was furnished in this condition by the organizational source and is the best copy available.
- This document may contain tone-on-tone or color graphs, charts and/or pictures, which have been reproduced in black and white.
- This document is paginated as submitted by the original source.
- Portions of this document are not fully legible due to the historical nature of some of the material. However, it is the best reproduction available from the original submission.

CR 151184

Final
Report

January 1977

**Flight
Representative
Positive Isolation
Disconnect**

(NASA-CR-151184) FLIGHT REPRESENTATIVE N77-18442
POSITIVE ISOLATION DISCONNECT Final Report
(Martin Marietta Corp.) 82 p HC A05/MF A01
CSCL 13E G3/37 Unclas
16348



Prepared for:
National Aeronautics and Space Administration
Lyndon B. Johnson Space Center
Houston, Texas



Contract NAS9-14926
DRL Number T-1277
DRL Line Item 4
DRD Number MA-183T
MCR-77-1

FINAL REPORT

FLIGHT REPRESENTATIVE
POSITIVE ISOLATION
DISCONNECT

January 1977

Prepared by:

Arthur A. Rosener
Thomas G. Jonkoniec

Approved by:

Arthur A. Rosener

Arthur A. Rosener
Program Manager

MARTIN MARIETTA CORPORATION
P. O. Box 179
Denver, Colorado 80201

FOREWORD

This document presents the results of work performed by the Martin Marietta Corporation's Denver Division for the National Aeronautics and Space Administration, Johnson Space Center. This final report was prepared as partial fulfillment of Contract NAS9-14926, *Flight Representative Positive Isolation Disconnect*. The NASA Technical Monitor was Mr. Frank Collier of the Space Shuttle ECS Section.

ABSTRACT

This report describes the effort to design, fabricate and test a flight representative positive isolation disconnect for component replacement in serviced liquid and gaseous spacecraft systems for NASA-Johnson Space Center under NASA Contract NAS9-14926. Initially, an engineering assessment was made of the test results from the feasibility PID test program conducted under NASA Contract NAS9-14376. Resolutions were developed for each problem encountered and a trade-off analysis was performed to select a final configuration for a flight representative PID that is reduced in size and comparable in weight and pressure drop to the developmental PID. A 6.35 mm (1/4-inch) line size PID was fabricated and tested. The flight representative PID consists of two coupled disconnect halves, each capable of fluid isolation with essentially zero clearance between them for zero leakage upon disconnect half disengagement. An interlocking foolproofing technique prevents uncoupling of disconnect halves prior to fluid isolation.

This report also recommends future development efforts and refers to Space Shuttle subsystems that would benefit from the use of the positive isolation disconnect. Customary units were utilized for principal measurements and calculations with conversion factors being inserted in equations to convert the results to the international system of units.

TABLE OF CONTENTS

	<u>Page</u>
FOREWORD	ii
ABSTRACT	iii
DISTRIBUTION LIST	iv
CONTENTS	v
ABBREVIATIONS	vii
I. PROGRAM SUMMARY AND RESULTS	I-1
A. Program Summary	I-1
B. Program Results	I-2
II. CONCLUSIONS AND RECOMMENDATIONS	II-1
A. Conclusions	II-1
B. Recommendations	II-1
III. TASK I - DETAILED ASSESSMENT	III-1
A. Purpose and Scope	III-1
B. Assessment of Development PID Test Results	III-1
C. Candidate Concepts	III-1
D. Concept Selection	III-10
E. Design Review	III-10
IV. TASK 2 - DESIGN FLIGHT REPRESENTATIVE DISCONNECT	IV-1
A. Purpose and Scope	IV-1
B. Yoke Spring Evaluation	IV-1
C. Final Design Configuration	IV-5
D. Evaluation of Concept for Application to Larger Sizes	IV-17
V. TASK 3 - DEVELOP FLIGHT REPRESENTATIVE DISCONNECT	V-1
A. Purpose and Scope	V-1
B. Fabrication of Flight Representative PID	V-1
C. Development Test Program	V-4
VI. FINAL DEVELOPMENT DESIGN	VI-1
A. Final Development Design Baseline	VI-1
B. Potential Shuttle Applications	VI-4

PRECEDING PAGE BLANK NOT FILLED

	<u>Page</u>
VII. QUALITY ASSURANCE, RELIABILITY AND SAFETY SUMMARY	VII-1
A. Quality Assurance	VII-1
B. Reliability	VII-2
C. Safety.	VII-3
APPENDIX A.	A-1

FIGURE

I-1 Assembled Flight Representative Positive Isolation Disconnect	I-3
I-2 FR/PID Cross-Section View	I-3
III-1 Concept No. 1	III-4
III-2 Concept No. 2	III-6
III-3 Concept No. 3	III-7
III-4 Concept No. 4	III-8
III-5 Concept Nos. 5 and 6	III-9
IV-1 Yoke Spring Test Sample Design.	IV-2
IV-2 Yoke Spring Aluminum Test Block	IV-3
IV-3 Yoke Spring Test Results.	IV-4
IV-4 FR/PID Detail Design Drawing.	IV-7
IV-5 FR/PID Cross-Section View and Top View.	IV-15
V-1 Assembled FR/PID (Side View).	V-2
V-2 Assembled FR/PID (Top View)	V-2
V-3 FR/PID Coupling Mechanism in Released Position.	V-2
V-4 FR/PID Halves Separated	V-3
V-5 FR/PID Component Half With Poppet Opened.	V-3
V-6 Line Half FR/PID With Protective Cap.	V-3
V-7 FR/PID Installed in Test Fixture.	V-5
V-8 FR/PID Test Setup and Instrumentation	V-5
V-9 Proof Test Internally Open.	V-7
V-10 Proof Test Internally Closed.	V-7
V-11 Gaseous Helium Leak Check	V-7
V-12 Freon-21 Exposure and Cycle	V-8
V-13 GN ₂ and H ₂ O Operational Life Cycle.	V-9
V-14 Hydraulic Lockup Test Configuration	V-11
V-15 Simulated Life Cycle Failure at Cycle 485	V-12
V-16 FR/PID Pressure Drop Test Results	V-16
VI-1 FR/PID Flow vs ΔP	VI-2
VI-2 FR/PID Flow vs ΔP (Calculated From Test Results)	VI-3

TABLE

III-1 Development PID Test Results Evaluation	III-2
III-2 Concept Comparison of Design Parameters	III-11
III-3 Advantages/Disadvantages of Concepts.	III-12
V-1 FR/PID Leakage Test Results	V-14

ABBREVIATIONS

A	Area
amb	Ambient
C	Compressibility Factor
cc	Cubic Centimeter
cm	Centimeter
Cos	Cosine
CRES	Corrosion Resistance Steel
Cyl	Cylinder
D	Diameter
dB	Decibel
defl	Deflection
displ	Displacement
DRL	Data Requirements List
ECLSS	Environment Control and Life Support System
EST	Estimate
F	Force
F-21	Freon-21
°F	Degree Fahrenheit
FR/PID	Flight Representative Positive Isolation Disconnect
FMEA	Failure Mode and Effect Analysis
ft	Foot
g	Acceleration of Gravity, 9.8 m/sec^2 (32.2 ft/sec^2)
GN ₂	Gaseous Nitrogen
GPM	Gallon Per Minute
GSE	Ground Support Equipment
H	Height
H ₂ O	Water
hr	Hour
Hz	Hertz
ID	Inside Diameter
IFM	Inflight Maintenance
in	Inch
k	Resistance Coefficient
°K	Degree Kelvin
kg	Kilogram
lb	Pound
lbf	Pound Force
m	Meter
min	Minute
ml	Milliliter
mm	Millimeter
MMC	Martin Marietta Corporation

N	Newton
N/m ²	Newton Per Square Meter
NASA	National Aeronautics and Space Administration
OD	Outside Diameter
P	Pressure
phm	Parts/Hundred Million
PID	Positive Isolation Disconnect
psi	Pounds Per Square Inch
psia	Pounds Per Square Inch Absolute
psid	Pounds Per Square Inch Differential
psig	Pounds Per Square Inch Gage
QAVT	Qualification for Acceptance Verification Testing
QD	Quick Disconnect
RH	Relative Humidity
sec	Second
Sin	Sine
SS	Stainless Steel
T, temp	Temperature
TBD	To Be Determined
TDC	Top Dead Center
V	Volume
wt	Weight

I. PROGRAM SUMMARY AND RESULTS

A. PROGRAM SUMMARY

The objective of this contract was to design, fabricate, and test a high reliability flight representative positive isolation disconnect (FR/PID). The FR/PID's purpose is for component replacement in serviced liquid and gaseous spacecraft systems. These spacecraft systems would consist of high purity water, coolant water, sweat and respiratory condensate, urine, ammonia, and Freon-21.

Maintenance of liquid and gaseous ECLSS components has always presented unique problems throughout **past flight** programs. Procedures utilized included--1) freezing of liquid lines adjacent to the component; 2) draining, purging, drying, and reservicing the liquid loop; 3) providing a redundant system; and 4) utilizing quick disconnects with spring-loaded shutoff poppets. The first two techniques usually resulted in trapped gas and required numerous exchanges of the system fluid to remove the entrapped free gas. In addition, this maintenance procedure had to be performed at test facilities that had sufficient GSE and trained technical personnel. The redundant system technique adds weight, volume, and costs to the spacecraft system.

Use of existing quick disconnects (QD) has also presented problems in the maintenance of fluid systems. These disconnects have poppets with spring-loaded actuation and closure features. After a period of time, the spring becomes corroded or contamination prevents the spring from closing the internal poppet on separation. Without a positive means of identifying that the poppet was isolated, a spillage could occur under pressure. Other problems with QDs are the male-female offset dimension of up to 19.05 mm (3/4-in.) and the opening and closing of the poppets with system pressure applied.

The FR/PID concept developed under this contract was designed to eliminate the problems of the previous maintenance techniques and eliminate the disadvantages of the existing quick disconnects. The program to develop the FR/PID consisted of four tasks as follows.

Task 1 - Perform Engineering Assessment - In this task the test results from the feasibility PID test program conducted under NASA contract NAS9-14376 were assessed and resolutions were developed for the problems encountered. Resolutions were selected based on a trade analysis and a design review was held with NASA to obtain their approval.

Task 2 - Design Flight Representative Disconnect - During this task, a flight representative design was developed based on the selected resolutions from Task 1. The intent of the design was also to reduce weight, size, and pressure drop compared to the NAS9-14376

PID design. Detail design drawings were prepared to depict the concept.

Task 3 - Develop Flight Representative Disconnect - In this task, one 6.35 mm (1/4-in.) line unit was fabricated in accordance with RES3157000 design drawings. The FR/PID was then subjected to development testing including proof pressure, hydraulic lockup, 512 life cycles of isolation, separation, and reconnection, internal and external leakage, and pressure drop.

Task 4 - Documentation and Delivery - This task prepared the documentation and reports required by the data requirements list (DRL) number T-1277. The conference documentation and hardware delivery was also prepared under this task.

The deliverable end products were a complete set of detailed design drawings, a complete test log and test summary, one 6.35 mm (1/4-in.) flight-representative positive isolation disconnect assembly, and DRL T-1277 documentation. A disconnect assembly consisted of two disconnect halves with the necessary operational tool.

B. PROGRAM RESULTS

1. FR/PID Description

One 6.35 mm (0.25-in.) FR/PID was designed, fabricated, and tested. The FR/PID consists of two coupled disconnect halves, each capable of fluid isolation with essentially zero clearance between them. Figure I-1 is the assembled FR/PID with both halves connected in the process of opening the internal poppets. The FR/PID as developed under this contract has the following design features.

- *Isolation Feature* - Fluid isolation is accomplished through the use of individually operated opposing spool poppets as shown in Figure I-2. The spool poppet is supported on shaft seals that slide in the valve housing center bore. In the center portion of the spool poppet is a recessed step sized to be slip-fit with the drive tabs on the yoke spring. The bottom end of the yoke spring is ball shaped and is the fixed pivot point. From this point the two legs of the yoke spring separate and straddle the spool poppet and this is where the drive tabs are located. The yoke spring legs continue past the spool poppet and end in a Y-configuration where the drive yoke is placed. The cam drive stem connects to the drive yoke and is driven by a torque limited hex key driver.

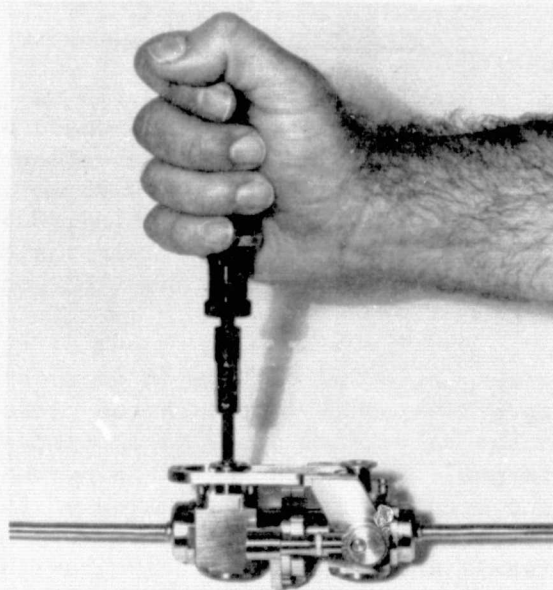

Figure I-1 Assembled Flight Representative Positive Isolation Disconnect

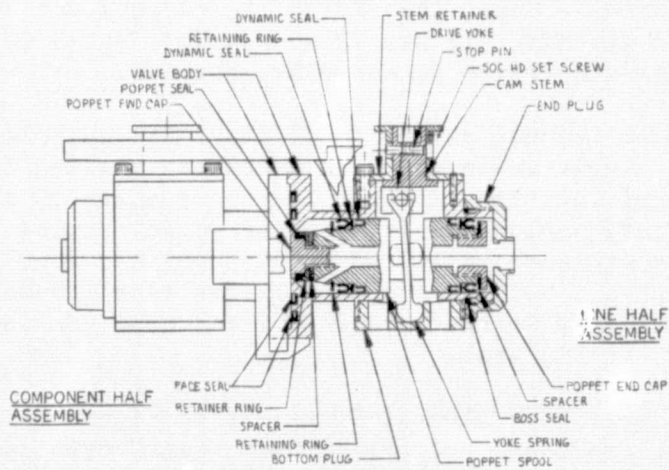

Figure I-2 FR/PID Cross-Section View

ORIGINAL PAGE IS
OF POOR QUALITY

The cam drive stem provides a total of 3.175 mm (0.125-in.) movement to the top of the yoke spring. This would normally translate the poppet spool 1.588 mm (0.062-in.), but closely machined spacers are incorporated to limit the travel to 0.99 mm (0.039-in.). The lost motion is taken up in spring deflection, 0.457 mm (0.018-in.) closed and 0.127 mm (0.005-in.) in the open position. The closed spring deflection provides 444.8 newtons (100 pounds force) on the poppet.

The design provides for 0.087 radians (5 degrees) over TDC for positive locking of the spool poppet in the closed and open position. A pin on the valve stem comes in contact with a pin stop to maintain this position. With the 444.8 newtons (100 lbf) load on the poppet and with the low surface area of the elastic and metal-to-metal seal, a loading of $5.7 \times 10^7 \text{ N/m}^2$ (8,320 psi) exists on the elastic seal, which is 11 times greater than the recommended loading for crushing possible contaminants. A loading of $1.87 \times 10^7 \text{ N/m}^2$ (2,720 psi) exists on the metal-to-metal seal where the recommended loading is $6.89 \times 10^6 \text{ N/m}^2$ (1,000 psi). If a contaminant becomes trapped between poppet and its seat and is not crushable, the torque limited actuator tool will release prior to reaching the designed stop position and without the valve stem in its proper place the units are incapable of being disengaged. This prevents the uncoupling of the disconnects when the poppets are not completely sealed.

- *Sealing Features* - Since the FR/PID is designed for several different fluid systems, all static and dynamic seals in the FR/PID are teflon or use teflon as the base material.

Redundant seal techniques are incorporated at dynamic sealing locations and single seals are used at static sealing locations. The redundant seal locations include the shaft seals on the moveable spool, separation plane seals, and the poppet seals. Two sets of double seals are used on the moveable spool and double seals on the separation plane, but the poppet utilizes metal-to-metal sealing for the redundancy in that area. The end caps use the standard MS33649 boss static seal.

The teflon seals have several different configurations. The separation plane seals are of the "omni-seal" type using a "rectangular" gland. The outer edge of the seal has a "bead" machined on that matches a machined recess in the outboard side of the gland. This provides seal retention when the disconnect halves are separated. The end caps use the "Raco" boss seals and the poppet uses a captured seal.

- *Coupling Feature* - The coupling feature consists of cam actuated clamp fingers that clasp the two disconnect halves together with a force of 3,069 newtons (690 lbs). The cam is part of the handle that lays across the top of the disconnect units. The clamp fingers consist of a pivot point at one end and a clamp yoke at the other with the center section made up of an adjustment screw with Belleville washers. The initial setup of the clamp is accomplished by tilting the handle back 0.4 radians (24 degrees) and adjusting the clamp finger until both disconnect halves are in contact with each other. When the handle is positioned flat across the FR/PID, the Belleville washers are deflected 0.23 mm (0.009-in.) of a possible 0.51 mm (0.020-in.) resulting in the clamp force of 3,069 newtons (690 lbs).
- *Foolproofing Technique* - To prevent the accidental disengagement of disconnect halves prior to fluid isolation, a foolproofing method is incorporated in the design. This consists of eccentric caps attached to the valve stems that coincide with slots in the coupling handle. When the disconnect halves are open, the eccentrics overlap the handle preventing its movement; likewise, when disconnect halves are closed, the handle is allowed to pass by the eccentrics and uncouple the unit.
- *Fluid Compression/Expansion* - Use of tapered poppets and matching poppet seats prevent fluid compression or expansion as sealing occurs when mating parts are contacted. For the situation where Freon-21 is trapped between the disconnects and a temperature rise takes place, the design incorporates a means of allowing the fluid to expand. For a 44^oK (80^oF) temperature rise, the units must allow for 0.010 mm (0.0004-in.) axial expansion. Since the clamping force is dependent on Belleville washer deflection, the required movement adds that amount to the deflection. Therefore, the clamping force increases from 3,069 newtons (690 lbs) to 3,202 newtons (720 lbs).
- *Interface Spillage Volume* - The poppet and poppet seat provide a flush surface, thereby minimizing possible leakage to only a wet surface. The thin water film on the separation plane will be retained by surface tension.
- *Separation Plane Lateral Movement* - The design provides a 1.143 mm (0.045-in.) concentric offset for centering one disconnect half to the other. Therefore, a lateral movement of 1.27 mm (0.050-in.) would be satisfactory for component removal as compared to disconnects requiring lateral movements up to 19 mm (0.75-in.) prior to separation.

- *Metal-to-Metal Contact* - Metal-to-metal contact in the fluid cavities is prevented by isolating the drive mechanism from the fluid with use of a spool poppet. The spool rides on shaft seals that slide in the valve housing. Surfaces with metal contact in the drive mechanism are lubricated to resist wear.
- *Operational Access* - All functions can be performed on one side of the unit, thereby limiting access requirements to a side normal to centerline of the FR/PID and fluid flow.
- *Materials* - Most parts are fabricated from 316 stainless steel due to its high corrosion resistance and strength properties. To further increase the materials' resistance to corrosion, all parts are passivated. The yoke spring and cam are made of 4340 carbon steel and heat-treated for wear resistance and strength. The end caps are fabricated from 316L stainless steel to facilitate welding to fluid lines.
- *Weight and Dimensional Criteria* - A complete disconnect unit with both halves and coupling mechanism weighs .61 kilograms (1.343 lbs). The complete FR/PID coupled has overall dimensions of 58.98 mm (2.322-in.) in width by 53.95 mm (2.114-in.) in height by 104.04 mm (4.096-in.) in length.
- *Fluid Compatibility* - The unit is compatible with operational fluids of high purity water, Freon-21, sweat and respiratory vapor, urine, coolant water, and nitrogen gas for periods up to 10 years.
- *Leakage Limitations* - The FR/PID is capable of meeting an external and internal zero leakage requirement of 1×10^{-6} scc/sec utilizing helium gas.
- *Operational Life Expectancy* - The PID is designed for an operational life expectancy of 5,000 cycles. Each cycle consists of isolate-disconnect-connect-flow.
- *Tool Requirement* - For normal FR/PID operation (which includes closing both disconnects, uncoupling, component replacement, coupling disconnects together, open disconnects), only a 4.75 mm (3/16-in.) Allen hex key adapted to a T-handle torque tool is required. For breakdown of the FR/PID, the required tools include a crescent wrench with an opening of 38.1 mm (1.50-in.), standard blade screw driver, and a set of Allen wrenches.

2. FR/PID Test Results

- *Proof Pressure* - The test unit showed no visible indication of permanent deformation or distortion and no loss of operating capability as a result of being subjected to $2.59 \times 10^6 \text{ N/m}^2$ (375 psig).
- *Hydraulic Lock Test* - The test unit successfully completed this test with no indication of hydraulic lockup and no increase in valve stem torque utilizing pressurized water at pressures of $1.72 \times 10^5 \text{ N/m}^2$ (25 psig) and $1.72 \times 10^6 \text{ N/m}^2$ (250 psig).
- *Operational Life Cycle Tests* - The test unit completed 512 cycles of closing the poppets, disconnecting the halves, reconnecting the halves, and opening the poppets utilizing water at $1.72 \times 10^6 \text{ N/m}^2$ (250 psig) for 250 cycles, gaseous nitrogen at $1.72 \times 10^6 \text{ N/m}^2$ (250 psig) for 250 cycles, and Freon-21 at $1.72 \times 10^6 \text{ N/m}^2$ (250 psig) for 12 cycles. No indication of the development problems that occurred during the Contract NAS9-14376 PID life cycle tests were observed during these tests. However, one new problem was encountered related to the component half bottom portion face flange cutout design. To prevent damage to the line half face seals, the edge should be rounded and slightly tapered backward to prevent sharp edges.
- *Leakage Tests* - The test unit was subjected to leakage tests at five different pressures between $3.4 \times 10^4 \text{ N/m}^2$ (5 psig) and $1.72 \times 10^6 \text{ N/m}^2$ (250 psig), utilizing water, gaseous helium, and Freon-21. The tests demonstrated that the design for all the seals is capable of meeting a zero leakage requirement of 1×10^{-6} scc/sec.
- *Pressure Drop Tests* - The pressure drop for a water flowrate of 0.063 kg/sec (500 lbs/hr) is $3.54 \times 10^4 \text{ N/m}^2$ (5.7 psid). The flow coefficient for the FR/PID was projected at 0.41. With the pressure drop reduction modifications incorporated (refer to Section VI.A), the pressure drop for a water flow rate of 0.063 kg/sec (500 lbs/hr) is $2.05 \times 10^4 \text{ N/m}^2$ (3.3 psid) and the flow coefficient for the FR/PID was projected at 0.55. The modification increased flow by 34 percent.

3. FR/PID Documentation Submittals

Documentation submittals were prepared and submitted in accordance with DRL Number T-1277. The following is a brief description of each submittal.

- *Monthly Progress Reports* - These reports summarized all work accomplished during each month. These reports were submitted as DRL Line Item 1, Martin Marietta number MCR-76-384.

- *Program Plan* - This document describes the overall plan for the conduct and implementation of the contract. This report was submitted as DRL Line Item 2, Martin Marietta number MCR-76-261.
- *Master Test Plan* - This document describes the Master Test Plan for the contract. This report was submitted as DRL Line Item 3, Martin Marietta number MCR-76-383.
- *Test Procedure* - This document provides the detail test procedures to accomplish the Master Test Plan. These procedures are identified as Martin Marietta number H40691.
- *Test Report* - This document contains the test log and summary of prototype development tests. It is identified as Martin Marietta Test Report H40691.
- *Detail Fabrication Drawings* - These drawings consist of detailing the design of the Positive Isolation Disconnect for fabrication purposes. These drawings are identified as RES3157000.
- *Final Report* - This report summarizes the results of the contract. It also contains the recommended future program for fabrication and testing of a flight prototype positive isolation disconnect. This report was submitted as DRL Line Item 4, Martin Marietta number MCR-77-1.
- *Cost and Manpower Charts* - These charts were incorporated in each Monthly Progress Report and depicted the actual and planned man-hour expenditures by month.
- *Master Schedule* - This schedule was incorporated in each monthly progress report and depicted the planned and actual progress during the contract.

5. PID Hardware Delivery

The hardware delivered under this contract consisted of the following:

- One 6.35 mm (1/4-in.) flight representative PID cleaned and assembled. One end cap was provided to protect the face seals when the halves were separated.
- One T-handle torque wrench with 4.76 mm (3/16-in.) hex drive preset at 17.29 cm-kg (15 in.-lb). This tool is used to open and close the poppets of the PID. The torque tool releases at the preset value when valves are closed and also has a backoff capability to facilitate opening the valves.

II. CONCLUSIONS AND RECOMMENDATIONS

A. CONCLUSIONS

1. The flight representative positive isolation disconnect delivered under this contract has demonstrated that it is a highly reliable maintainable concept for component or subsystem module replacement in liquid and gaseous spacecraft systems.
2. The problems encountered during the 5,000 life cycle test of the contract NAS9-14376 developmental PID were resolved during this contract.
3. The FR/PID concept is suitable for either Shuttle zero-gravity IFM or for ground refurbishment purposes.
4. The FR/PID is currently comparable to other developed disconnects in size and weight for the same line sizes. A complete FR/PID with both halves and coupling mechanism weighs 0.61 kilograms (1.343 lbs) and has overall dimensions of 58.98 mm (2.32-in.) in width by 53.95 mm (2.11-in.) in height, and 104 mm (4.10-in.) in length for 6.35 mm (1/4-in.) line size.
5. This concept does have commercial application to replace conventional hazardous liquid disconnects utilizing spring-loaded valves, which do not have an interlock system to prevent disengagement if one or both valves fail to close due to spring corrosion or contamination. The design eliminates operator errors and accidental spills thus increasing the safety in handling hazardous fluids.

B. RECOMMENDATIONS

This program has demonstrated that the PID is a feasible concept for both spacecraft and commercial applications of maintenance. Based on the results of this program, it is recommended that continued development of the PID be accomplished. The next step should be the development of a flight article prototype to investigate the following:

- *Man/Machine Interface Testing* - Determine both shirtsleeve and pressure-suited crewman interface with FR/PID under simulated weightlessness conditions.

- *Investigate Vibration/Acceleration PID Effects* - Perform limited vibration/acceleration testing of the integral clamping mechanism utilizing the FR/PID.
- *Investigate Adaptability to Larger Sizes and Higher Pressures* - Investigate possible uses of PID for sizes up to 50.8 mm (2-in.) and pressures to 3.1×10^7 N/m² (4,500 psig).
- *Develop Prototype Design* - Develop a flight article prototype based on the above investigations and consider production type units utilizing castings as well as reducing, size, weight, and pressure drop.
- *Fabricate Prototype Design* - Fabricate one 6.35 mm (0.25-in.) and one 12.7 mm (0.50-in.) flight article prototype.
- *Perform Prototype Testing* - Consider additional life cycle tests and a complete environmental test program per Shuttle MF 0004-014 requirements.

In addition to the above, the FR/PID should be investigated for remote operation with a manipulator system. Application of a PID is required when removing modules or performing inflight maintenance with a remote manipulator or free flyer teleoperator. End effector interface and limitations of rotational and push/pull movements must be considered on closing/opening the poppet valves and disconnecting/connecting the two halves. Consideration must also be given to the design for general purpose remote control or a one push/pull operation fully automated. The recommended effort for this task would be to investigate a design for closing both poppets at the same time and the interface end effector design.

III. TASK I - DETAILED ASSESSMENT

A. PURPOSE AND SCOPE

The purpose of Task I was to assess the results from the developmental PID test program and develop resolutions for the problems encountered. Based upon the resolutions to the problem areas, candidate concepts were developed and evaluated. A concept was selected and a design review was conducted at NASA-JSC.

B. ASSESSMENT OF DEVELOPMENT PID TEST RESULTS

The development PID test program was reviewed. The following design features were found to be acceptable from testing data:

1. Fluid Isolation Technique - The development PID utilized opposing poppets. Tests verified that "hydraulic-lockup" did not occur and that spillage at separation was a minimum.
2. Coupling Technique - The development PID used a lever-cam mechanical coupling technique. This clamping method was relatively compact and lent itself nicely for foolproofing.
3. Foolproofing Technique - The development PID used eccentrically shaped caps on the valve stems that coincided with slots in the coupling handle. When the disconnect halves were open, the eccentrics overlapped the handle preventing its movement; likewise when disconnect halves were closed, the handle was allowed to pass by the eccentrics and uncouple the unit.

The problem areas encountered along with the probable cause determined and the corresponding recommended corrective action is summarized in Table III-1.

C. CANDIDATE CONCEPTS

Six concepts were generated which resolved the Contract NAS9-14376 development test problems. These are described as follows:

Table III-1 Development PID Test Results Evaluation

PROBLEM	PROBABLE CAUSE	POSSIBLE CORRECTIVE APPROACH
1. Poppet O-ring Blowout	As the poppet was withdrawn from the sealing seat, the contained pressure acting on the O-ring caused it to rise and slide into the increased clearance area. The O-ring continued to seal the opening until it was completely stretched out of the seal gland.	<ol style="list-style-type: none"> 1. A molded elastomer seal capsulated into the poppet assembly in same manner as the teflon poppet seal in the feasibility PID (Dwg #NAS9-14376-A-089). 2. A tighter dovetail form to provide more squeeze on the O-ring. 3. Additional bleed holes from the inner surface of the O-ring gland to the front surface of the poppet to remove the high pressure differential from under the seal at the moment of opening.
2. Discrepancy in Stop Position	<ol style="list-style-type: none"> 1. Pin stop attachment not secure, resulting from excessive applied force repeatedly during cycling without a force limiting device. 2. Loosening of poppet on poppet shaft, thereby allowing the poppet to bottom out prior to pin contacting stop, or loosening in the opposite direction would create an incomplete closure when pin contacts stop. The design feature on the feasibility PID involved a jamb nut compressing the teflon seal material. This material could "set" in time allowing the poppet to loosen. 	<ol style="list-style-type: none"> 1. Open/close operation to be performed with a torque wrench with properly set breakaway point. Pin stop redesign to not being dependent on friction of hold screws. 2. Positive means of locking poppet to poppet shaft to be incorporated. Poppet should be pinned to shaft, or the use of set screws to meet the requirement. "Lock-Tite" to be used as a minimum.
3. Poppet Seal Leaking and Producing a Popping Sound	<ol style="list-style-type: none"> 1. Poppet was loose on shaft and out of adjustment resulting in leakage. Looseness in poppet drive resulted in popping sound during pressure variations such as backing the poppet off its seat under pressure. 2. Permanent deformation was observed on leaf springs which would account for some "looseness" when the poppet drive cam was in the overcenter position. 	<ol style="list-style-type: none"> 1. A positive means of locking poppet to poppet shaft to be incorporated as discussed in problem No. 2. 2. The flight representative design will not utilize the leaf spring configuration as in the feasibility PID, but attempt to use a "yoke" type spring with a lower spring rate for the same poppet force and being able to operate below the yield stress level.
4. Interface Seal Blowout	<ol style="list-style-type: none"> 1. Seal retention technique was marginal. 2. In most cases the poppet in the adjacent PID half was leaking upon PID half separation allowing high pressure gas to unseat the seal. 	<ol style="list-style-type: none"> 1. Reduce the outside diameter of the omni-seal groove to slightly interface with the outside diameter of the omni-seal. 2. Provide gland relief vent holes for pressure equalization.
5. Handle Mechanism Tightness/Looseness	This condition occurred when a rapid temperature variation in flowing fluid took place, ΔT 55.6°K (100°F). This caused the main body of the unit to expand/contract at a faster rate than the clamp legs. Total variation was .036 mm (.0014 in.), for a length of 42.6 mm (1.678 in.) body from pivot centerline to clamp interface.	<ol style="list-style-type: none"> 1. A sufficient number and available deflection of Belleville washers is required in the clamp mechanism to allow for the additional expansion or contraction and still provide the desired clamp force at either end of the operating temperature range. 2. Thermally nonisolate clamp legs from main body.
6. Interface Seal Leakage	Interface seals will leak if insufficient compression of seals occurs as in problem No. 5.	The corrective action taken in the fix of problem No. 5 will provide the proper compression on the face seals to eliminate interface seal leakage.
7. Valve Stem Seal Leakage	Seals were not completely seated. After seals are pressurized and expanded proper sealing will occur.	The improved design would permit no fluid in the valve stem operating mechanism area. Dual seals would be used on the poppet shuttle.
8. Deterioration of 4.75 mm (3/16") hex on Valve Stem	The process of installing tool and centering tool to hex stem could wear off the corners on small hexes.	<ol style="list-style-type: none"> 1. A large hex of 5/16 in. will be used on the revised design. 2. Heat treat stem material to allow hardening for wear resistance.
9. Valve Stem Hard to Turn	Binding of internal drive mechanism when leaf springs would slip out of proper location.	<ol style="list-style-type: none"> 1. The revised design will incorporate a different spring configuration and retention to eliminate this problem. 2. Eliminate leaf spring poppet loading technique.

- *Concept 1* - This concept utilizes the valve body and several detail parts from the development PID unit (see Figure III-1). The main objective of this concept is to modify internal parts as required to resolve problems encountered in the development testing program. The following are the design changes that resolve the problems previously listed.
 - 1) "Problem 1" is eliminated by the use of machined or molded seals captured in the front piece of the poppet.
 - 2) Two solutions to "Problem 2" are incorporated--one being a torque setting on the operating tool less than that of the clamp force of the hold-down screws on the pin stop ring. The second method is to have spanner wrench holes on the poppet to ensure that a proper amount of jaming force can be applied to the poppet and jamb nut to maintain the set position.
 - 3) "Problem 3" is solved by eliminating a looseness condition at the poppet by use of spanner wrench holes on the poppet as described in item 2). The leaf spring configuration is replaced by a Belleville washer assembly. The force-deflection characteristics of the Belleville washers are predictable and dependable.
 - 4) For "Problem 4", more of an interference fit is sought between the outside diameter of the omni-seal and the outside diameter of the seal groove.
 - 5) "Problem 5" is resolved by redesigning the clamp end to allow for either expansion or contraction and still maintain acceptable clamping force.
 - 6) "Problem 6" is eliminated when the solution to "Problem 5" is incorporated and maintains proper clamping force.
 - 7) "Problem 7" will be solved when proper surface finishes are on the valve stem and housing and the seals become completely seated.
 - 8) A larger "hex" is the design change that eliminates "Problem 8".
 - 9) The different yoke configuration should repeatedly work smoothly and "Problem 9" should not appear.

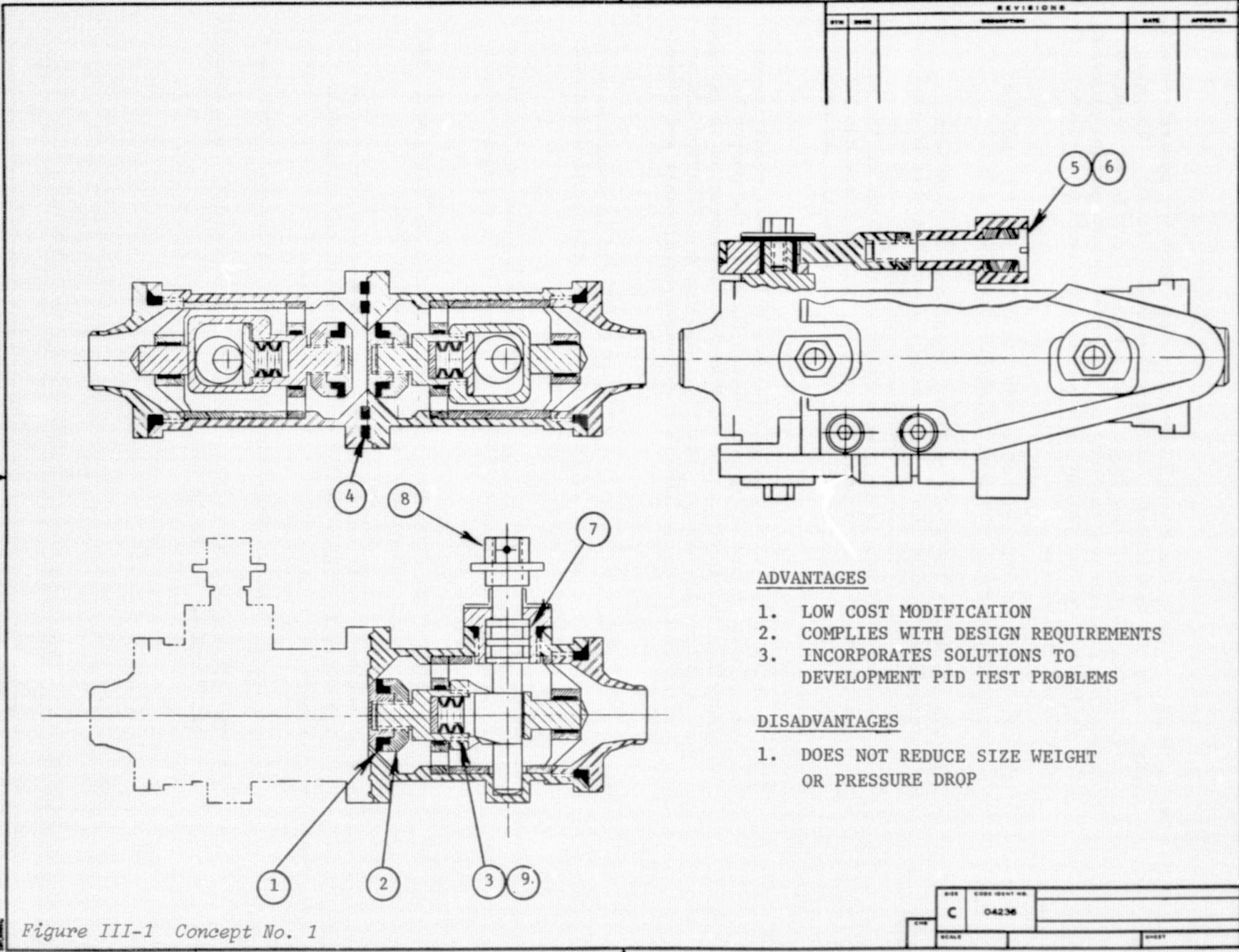

ADVANTAGES

- 1. LOW COST MODIFICATION
- 2. COMPLIES WITH DESIGN REQUIREMENTS
- 3. INCORPORATES SOLUTIONS TO DEVELOPMENT PID TEST PROBLEMS

DISADVANTAGES

- 1. DOES NOT REDUCE SIZE WEIGHT OR PRESSURE DROP

Figure III-1 Concept No. 1

REV	CODE IDENT NO	
C	04236	
DATE		SHEET

- *Concept 2* - This concept uses the valve body for the poppet guide (see Figure III-2). The poppet has a straight-through bore, the same diameter as the tube ID with six holes flared out at the seal end. A slot is provided for a slip fit of the valve stem-cam. The cam also has a straight-through bore which lines up with the poppet bore when the valve is in the open position. This combination provides for a short assembly with a low pressure drop. Poppet length adjustment is made so the cam does not go overcenter when poppet is fully open or closed. This provides for a high sealing force.
- *Concept 3* - This concept--as in Concept 2--utilizes the valve body as the poppet guide and incorporates the straight-through bore concept (see Figure III-3). The poppet can slide on seals or a teflon liner. The poppet drive is a yoke spring that straddles the poppet and sets in a groove machined on the poppet. A ball end at the base of the yoke pivots in a bottom plug. The top end of the yoke spring picks up the collar driven by an eccentric pin on the valve stem. Weight savings and size reduction are of minimal amount, but the pressure loss reduction is significant.
- *Concept 4* - This concept is identical to Concept 3 except the bottom cap seal and the valve stem seal are eliminated (see Figure III-4). This is due to the fact that the valve body bore and the poppet diameter are to be close tolerance machined parts with a smooth surface finish to provide sealing along these surfaces. This isolates the drive mechanism from the fluid flow which prevents any contamination generated from entering the flow passages. The straight-through flow path is beneficial in reducing pressure loss through the unit and a slight size and weight reduction compared to the development PID may be possible.
- *Concept 5* - This concept is similar to Concept 4 in that the driving mechanism is isolated from the fluid media (see Figure III-5). A slide ring positioned between two sets of Belleville washers becomes the drive mechanism. Attached to this slide ring are a pair of pins that are driven by an overcenter linkage assembly. This design locks the poppet in the open and closed positions. As in Concept 4, external leakage is sealed between poppet and valve housing. This concept provides for a low pressure drop with its straight-through flow passage in the poppet.
- *Concept 6* - This concept is identical to Concept 5 except in the driving mechanism (see Figure III-5). This concept uses an eccentric cam that is attached to the slide ring and performs the same function as the linkage in Concept 5.

REVISIONS				
BY	DATE	DESCRIPTION	DATE	APPROVED

HOLE BORED THRU
CAM IN-LINE WITH
CENTERLINE OF TUBE

.150 POPPET
TRAVEL

ADVANTAGES

1. REDUCTION IN SIZE
2. REDUCTION IN WEIGHT
3. REDUCTION IN PRESSURE LOSS

DISADVANTAGES

1. NO POSITIVE OPEN OR SHUT MECHANISM EXCEPT CAM JAMMING ON POPPET!

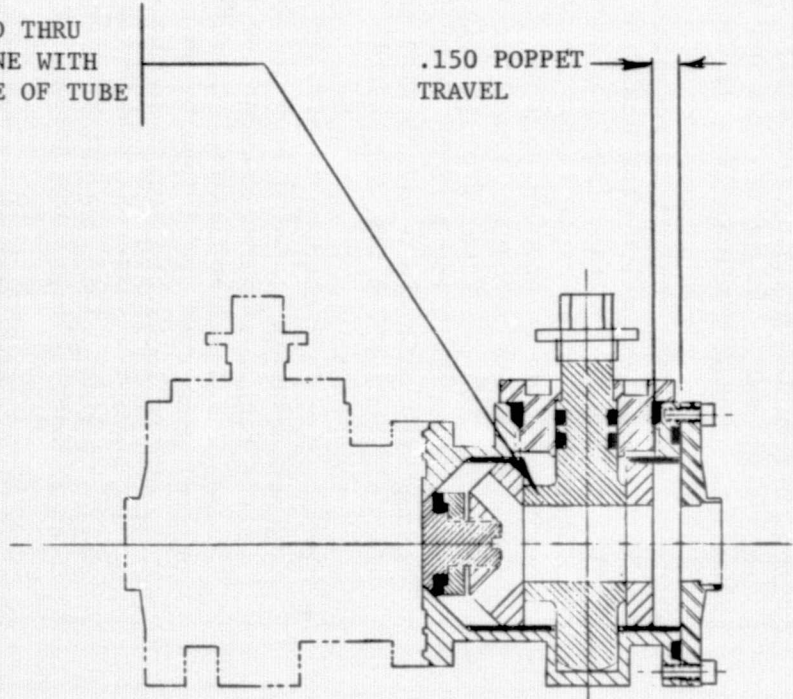

1/2" LINE UNIT

Figure III-2 Concept No. 2

SIZE	APP. WEIGHT (G)	
C	04236	
SCALE		SHEET

REVISIONS				
SYM	DATE	DESCRIPTION	DATE	APPROVED

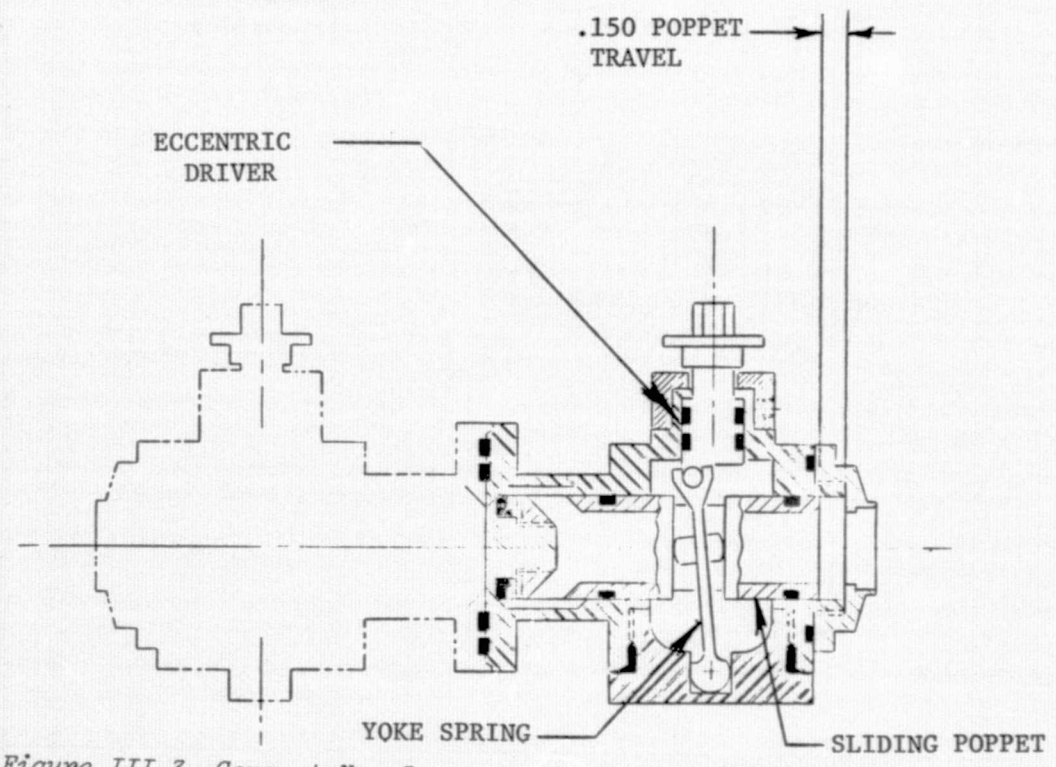

ADVANTAGES

- 1. LOW PRESSURE DROP
- 2. SLIGHT REDUCTION IN SIZE AND WEIGHT

DISADVANTAGES

- 1. SEVERAL CLOSE TOLERANCE PARTS TO BE MACHINED

Figure III-3 Concept No. 3

REV	EDGE IDENT NO	
C	04236	
SCALE		SHEET

REVISIONS				
REV.	BY	DATE	DESCRIPTION	APPROVED

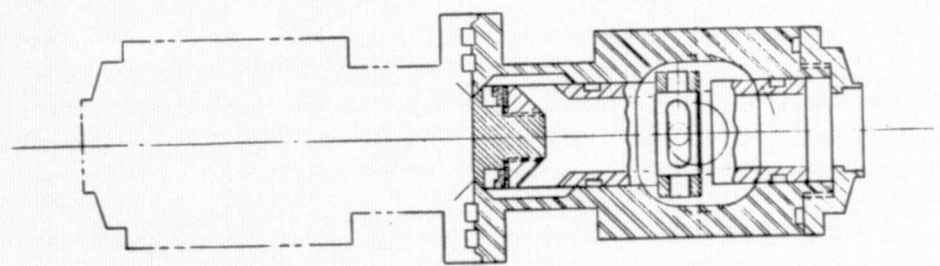

POPPET ISOLATION SEALS

.150 POPPET TRAVEL

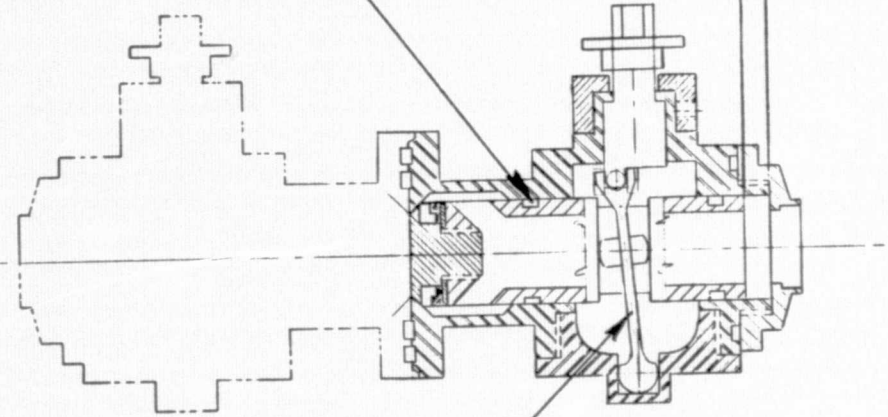

YOKE SPRING

ADVANTAGES

1. LOWER PRESSURE DROP
2. DRIVE MECHANISM ISOLATED FROM FLUID

DISADVANTAGES

1. CLOSE TOLERANCE MACHINING REQUIRED

Figure III-4 Concept No. 4

SIZE	CORE IDENT NO.	
C	04236	
SCALE		SHEET

REVISIONS				
BY	DATE	DESCRIPTION	DATE	APPROVED

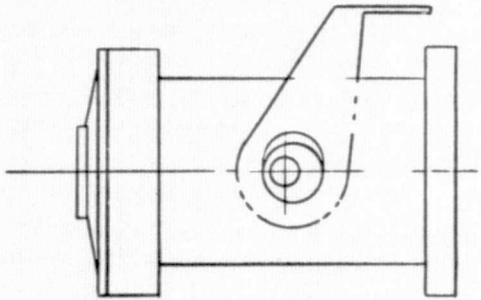

CONCEPT NO. 6

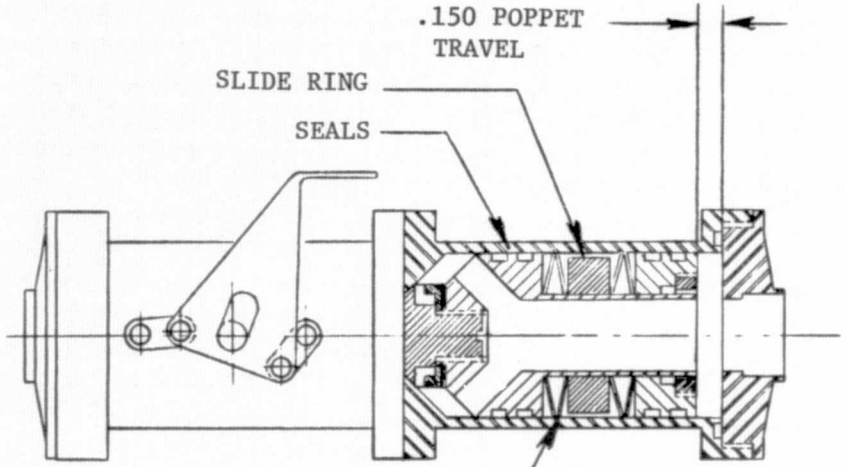

CONCEPT NO. 5

ADVANTAGES

1. LOW PRESSURE DROP
2. DRIVE MECHANISM ISOLATED FROM FLUID
3. LOWER WEIGHT
4. SMALLER SIZE

DISADVANTAGES

1. SEVERAL CLOSE TOLERANCE INTERCONNECTING PARTS
2. DEVELOPMENT PID COUPLING DEVICE IS NOT ADAPTABLE

6-III

Figure III-5 Concept No.s 5 and 6

REV	CODE IDENT NO	
C	04236	
SCALE		SHEET

D. CONCEPT SELECTION

The six candidate concepts were evaluated and compared against the contract SOW design parameters. This comparison is shown in Table III-2. Table III-3 summarizes advantages/disadvantages of the six concepts. Concept four was tentatively selected based upon the following:

- Lower pressure drop;
- Slight reduction in envelope size;
- Slight reduction in weight;
- Meets all design requirements;
- Incorporates solutions to development PID test results;
- Drive mechanism isolated from fluid.

The materials selected for the concept included the following:

- Valve body and miscellaneous details - 316L stainless steel, based on compatibility with urine and F-21, machineability and weldability;
- Yoke leaf spring - 4340 carbon steel, heat treatable to 1.85×10^{10} N/m² (268,000 psi) yield strength;
- Details in contact with fluids - .316 stainless steel due to its high corrosion resistance;
- Seal material - Teflon, based on compatibility with urine and F-21.

E. DESIGN REVIEW

The preliminary design review was held August 6, 1976 at NASA-JSC. A preliminary design review data package on the concepts generated was submitted and discussed. The following is a summary of the meeting with action items.

1. Concept No. 4, "Center Bored Poppets with Isolated Yoke Spring Drivers" was selected from the preliminary design review data package as the configuration to be detail designed with the following modifications and restrictions:

Table III-2 Concept Comparison of Design Parameters

CONCEPT	CONCEPT NO. 1	CONCEPT NO. 2	CONCEPT NO. 3	CONCEPT NO. 4	CONCEPT NO. 5	CONCEPT NO. 6
DESIGN PARAMETERS	Developmental PID with Internal Modifications	Center Bored Poppet with Center Bored Cam Driver	Center Bored Poppet with Yoke Spring Driver	Center Pored Poppet with Isolated Yoke Spring Driver	Center Bored Poppet with Isolated Over-center Linkage Driver	Center Bored Poppet with Isolated Side Mounted Cam Driver
Cost, Fabrication and Assembly	Low; housing and clamp details used from dev. PID	Moderate; all new detail parts	Moderate to high; relatively difficult details to machine	High, surface finish on bore must be polished	High; surface finish on bore must be polished and several close tolerance parts	High; surface finish on bore must be polished and several close tolerance parts
Wear During Cycling	Low; dry lube applied to cam shaft in areas that contact yoke and main body. Belleville washers compensate for wear and maintain sealing force	Critical; no spring deflection to compensate for wear. Dry lube applied to cam	Low; dry lube applied to parts in contact. Yoke spring compensates for wear and maintain sealing force	Low; dry lube applied to parts in contact. Yoke spring compensates for wear and maintain sealing force	Low; dry lube applied to linkage pivot points. Belleville washers compensate for wear and maintain sealing force	Low; dry lube applied to cam surfaces, Belleville washers compensate for wear and maintain sealing force
Positioning Precision Requirement	Moderate; valve housing, guides and poppet must be concentric. Poppet length is adjustable	Low; poppet and housing concentricities must be held. Poppet length is adjustable	High; several close tolerance fitting parts; poppet length is adjustable	High; several close tolerance fitting parts; poppet length is adjustable	Very high; several close tolerance fitting parts on both sides of valve body. Poppet length is adjustable	Very high, cam cutout on valve body is very critical. Poppet length is adjustable
Susceptible to Hydraulic Lockup	No	No	No	No	No	No
Lateral Movement for Separation	1.016-1.143 mm (.040-.045 in.)	1.016-1.143 mm (.040-.045 in.)	1.016-1.143 mm (.040-.045 in.)	1.016-1.143 mm (.040-.045 in.)	1.016-1.143 mm (.040-.045 in.)	1.016-1.143 mm (.040-.045 in.)
Spillage Volume	Minimum; face film only	Minimum; face film only	Minimum; face film only	Minimum; face film only	Minimum; face film only	Minimum; face film only
Redundant Sealing	Teflon seal and metal-to-metal seal at poppet. Single static seals at threaded caps. Double seals on valve stem. Double face seals at separation plane.	Teflon seal and metal-to-metal seal at poppet. Single static seals at end caps. Double seals on valve stem. Double face seals at separation plane.	Teflon seal and metal-to-metal seal at poppet. Single dynamic seals on end caps. Double seals on valve stem. Double face seals at separation plane.	Teflon seal and metal-to-metal seal at poppet. Single dynamic seals on poppet and end caps. Double face seals at separation plane.	Teflon seal and metal-to-metal seal at poppet. Double dynamic seal on poppet. Single end cap seal. Double face seals at separation plane.	Teflon seal and metal-to-metal seal at poppet. Double dynamic seals on poppet. Single end cap seal. Double face seals at separation plane.
Single Port Flow Area	Annular flow around poppet then thru guides and around valve stem	Annular flow around poppet then thru center port	Annular flow around poppet then thru center port	Annular flow around poppet then thru center port	Annular flow around poppet then thru center port	Annular flow around poppet then thru center port
Metal-to-Metal Contact Between Sliding Surfaces	Valve stem to yoke (lubed); valve stem to body (lubed)	Valve stem to poppet (lubed). Valve stem to body (lubed)	Yoke spring to poppet and body and drive mechanism (all lubricated)	Yoke spring to poppet and body and drive mechanism (all external to fluid path and lubricated)	Slide block on poppet drive linkage (all external to fluid path and lubricated)	Slide block on poppet cam drive assembly (all external to fluid path and lubricated)
Single Side Access	Yes	Yes	Yes	Yes	Yes	Yes
Operational Tools Required	Socket type torque tool for valve stems. Built-in handle for coupling	Socket type torque tool for valve stems. Built-in handle for coupling	Socket type torque tool for valve stems. Built-in handle for coupling	Socket type torque tool for valve stems. Built-in handle for coupling	Built-in handle for poppet driving and coupling	Built-in handle for poppet driving and coupling
Maintain Mode During Vibration	Overcenter cam spring loaded on poppet and coupler	Jamming force on valve stem cam. Spring loaded over-center cam on coupler	Overcenter cam spring loaded on poppet and coupler	Overcenter cam spring loaded on poppet and coupler	Overcenter linkage spring loaded overcenter spring loaded cam coupler	Overcenter cam spring loaded on poppet and coupler
Vacuum Sealing	Seal orientation must be reversed	Seal orientation must be reversed	Seal orientation must be reversed	Seal orientation must be reversed	Seal orientation must be reversed	Seal orientation must be reversed
Stagnant Areas	Yoke cavity where Belleville washers are located	None	Possibly in poppet drive cavity if leakage occurs past poppet seals	None	None	None
Overall Size Compared to Developmental PID	Same	75 percent of development PID	Slight reduction	Slight reduction	Slight reduction	Slight reduction
Overall Pressure Drop Compared to Development PID	Same	Definitely reduced	Definitely reduced	Definitely reduced	Definitely reduced	Definitely reduced

ORIGINAL PAGE IS OF POOR QUALITY

Table III-3 Advantages/Disadvantages of Concepts

CONCEPT	ADVANTAGES	DISADVANTAGES
1	<ul style="list-style-type: none"> ● Low cost modification ● Complies with design requirements ● Incorporates solutions to design problem 	<ul style="list-style-type: none"> ● Does not reduce size, weight, or pressure drop
2	<ul style="list-style-type: none"> ● Reduction in size, weight and pressure loss 	<ul style="list-style-type: none"> ● No positive open or shut mechanism except cam jaming on poppet
3	<ul style="list-style-type: none"> ● Low pressure drop ● Slight reduction in size and weight 	<ul style="list-style-type: none"> ● Several close tolerance parts to be machined ● Drive mechanism not isolated from fluid
4	<ul style="list-style-type: none"> ● Low pressure drop ● Drive mechanism isolated from fluid ● Slight reduction in size and weight 	<ul style="list-style-type: none"> ● Close tolerance machining required
5	<ul style="list-style-type: none"> ● Low pressure drop ● Drive mechanism isolated from fluid ● Lower weight ● Smaller size 	<ul style="list-style-type: none"> ● Several close tolerance interconnecting parts ● Development PID coupling device not adaptable--new development
6	<ul style="list-style-type: none"> ● Low pressure drop ● Low weight ● Drive mechanism isolated from fluid 	<ul style="list-style-type: none"> ● Several close tolerance interconnecting parts ● Development PID coupling device is not adaptable

- a. Redundant seals shall be incorporated in front and behind yoke spring groove on the poppet spool detail.
 - b. Poppet seals shall permit vacuum purging without leakage. (MMC to check seal manufacture to determine capability.)
 - c. Poppet position indicator nomenclature to be revised for clarity.
 - d. Teflon seals to be incorporated throughout the design.
2. Detail design drawings shall describe a 6.35 mm (1/4-inch) line FR/PID only. A written description of deviations for larger size units shall be prepared.
 3. A pressure leak test and/or other tests shall be performed to satisfactorily demonstrate the operational characteristics of the coupling mechanism.
 4. A preset torque tool shall be provided, preferably with a tee handle.
 5. Testing shall consist of 500 life cycles. The master test plan shall be updated to reflect this change.
 6. Emphasis shall be made during detail design for weight and size reduction.

IV. TASK 2 - FLIGHT REPRESENTATIVE DISCONNECT DESIGN

A. PURPOSE AND SCOPE

The purpose of this task was to develop the selected concept into a detailed design that could be fabricated and tested with a reliable confidence of meeting the contract design requirements. In addition, the application of the concept to larger size limits was evaluated.

B. YOKE SPRING EVALUATION

The selected concept incorporates a yoke spring design that isolates the actuation components from the fluid media. Since the yoke spring was a novel design, a test was required to tabulate the force-deflection characteristics of the spring prior to design acceptance. The yoke spring design is critical because the stress level is high and the deflection is negligible. Four sample leaf springs were fabricated (Figure IV-1) with thicknesses of 1.016 mm (.040 in.), 1.27 mm (.050 in.), 1.524 mm (.060 in.) and 1.803 mm (.071 in.). An aluminum test block (Figure IV-2) was fabricated. The springs were tested by placing the leaf springs over the test block with the imaginary location of the drive tabs positioned over the adjustable stop screws. A press wedge was then placed over the leaf spring and in line with the stop screws. A hand-held force gage was placed on top of the press wedge and was used for loading the springs. The stop screws were lowered in .05 mm (.002 in.) increments and the spring was deflected until it contacted the stop screws. At this time the force reading was recorded for various deflections. From this data the force-deflection curves in Figure IV-3 were plotted. The springs were deflected until permanent deformation occurred and is indicated as the yield point on the curves.

From this test data and analytical calculations, a decision was made to use a thickness of 1.524 mm (.060 in.) for the yoke spring. This provides the desired 444.8 newtons (100 lbf) loading on the poppet with .457 mm (.018 in.) yoke spring deflection. This nominal deflection is large enough so that if the actual deflection after tolerance buildup of affected parts varies by a couple thousandths of an inch, the poppet loading is still in an acceptable range. Also, the deflection is not great enough to hinder the required displacement of the poppet spool.

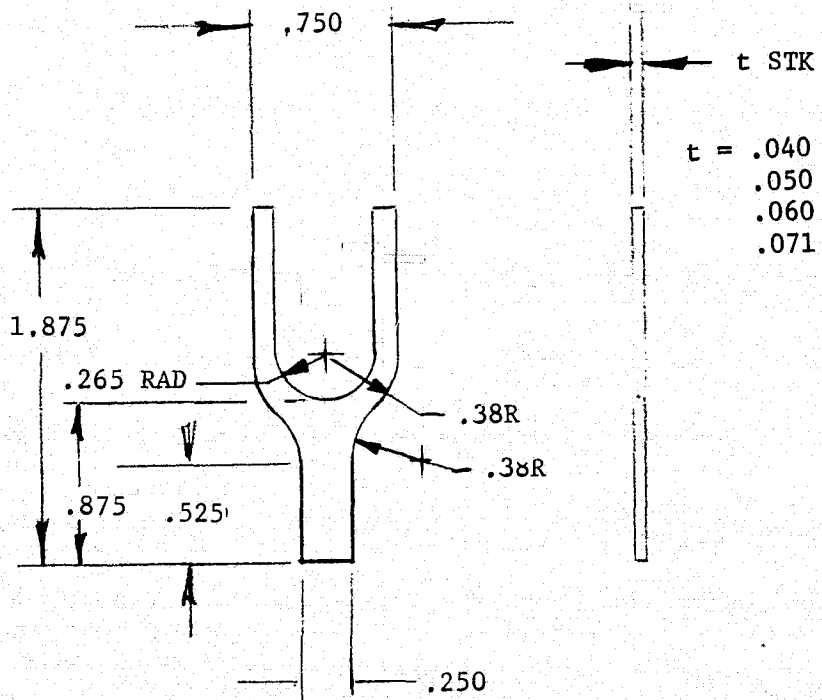

Material: 4130 Steel Sheet
 Heat Treat: 250,000 Psi (Rockwell 50C)

Figure IV-1 Yoke Spring Test Sample Design

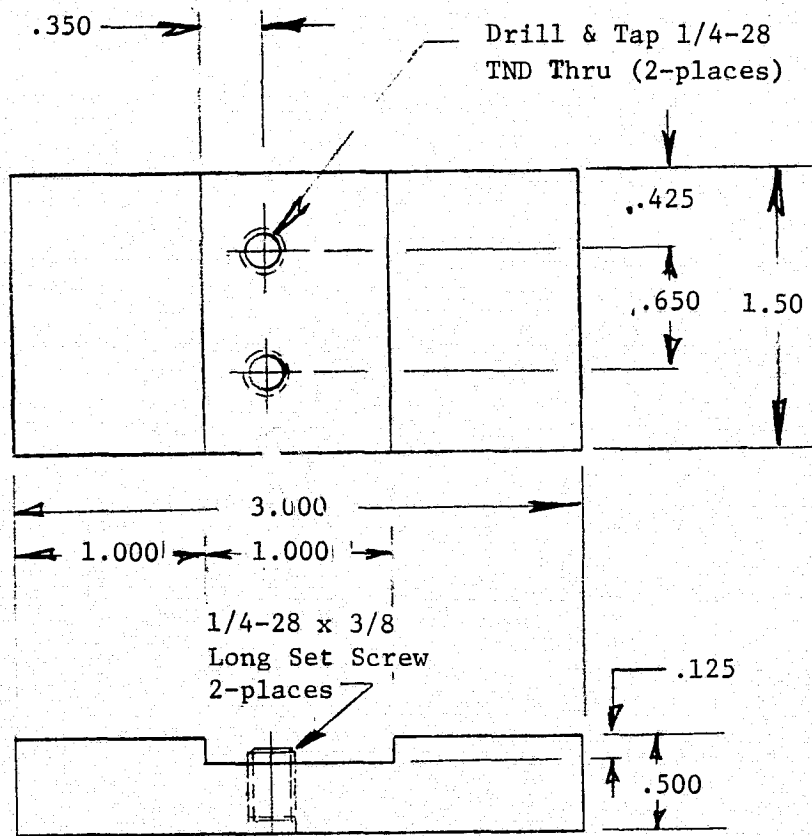

Material: Alum 6061-T6

Quantity: 1

Figure IV-2 Yoke Spring Aluminum Test Block

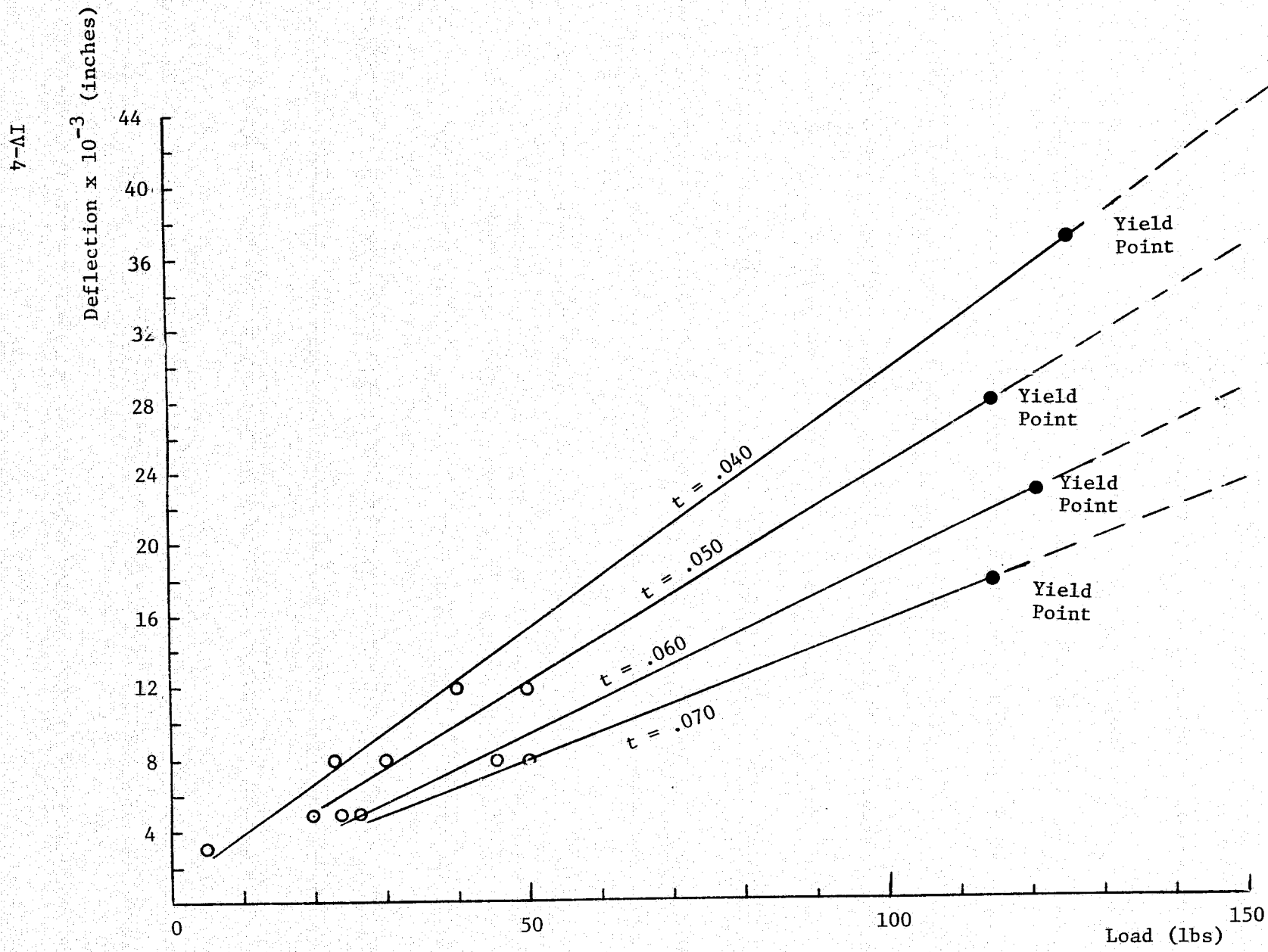

Figure IV-3 Yoke Spring Test Results

C. FINAL DESIGN CONFIGURATION

The final configuration is a result of the previous evaluations and testing. The final design drawings are shown in Figure IV-4. The FR/PID consists of two coupled disconnect halves, each capable of fluid isolation with essentially zero clearance between them providing for zero leakage upon disconnect half disengagement. The following is a description of the FR/PIDs elements:

- *Isolation Feature* - Fluid isolation is accomplished through the use of individually operated opposing spool poppets as shown in Figure IV-5. The spool poppet is supported on shaft seals that slide in the valve housing center bore. In the center portion of the spool poppet is a recessed step sized to be slip fit with the drive tabs on the yoke spring. The bottom end of the yoke spring is ball shaped and is the fixed pivot point. From this point the two legs of the yoke spring separate and straddle the spool poppet and this is where the drive tabs are located. The yoke spring legs continue past the spool poppet and end in a Y-configuration where the drive yoke is placed. The cam drive stem connects to the drive yoke and is driven by a torque limited hex key driver.

The cam drive stem provides a total of 3.175 mm (.125 in.) movement to the top of the yoke spring. This would normally translate the poppet spool 1.588 mm (.062 in.), but closely machined spacers are incorporated to limit the travel to 0.99 mm (.039 in.). The lost motion is taken up in spring deflection, 0.457 mm (.018 in.) closed and 0.127 mm (.005 in.) in the open position. The closed spring deflection provides 444.8 newtons (100 pounds force) on the poppet.

The design provides for .087 radians (5 degrees) over TDC for positive locking of the spool poppet in the closed and open position. A pin on the valve stem comes in contact with a pin stop to maintain this position. With the 444.8 newtons (100 lbf) load on the poppet and with the low surface area of the elastic and metal-to-metal seal, a loading of 5.7×10^7 N/m² (8320 psi) exists on the elastic seal, which is 11 times greater than the recommended loading for crushing possible contaminants, and a loading of 1.87×10^7 N/m² (2720 psi) exists on the metal-to-metal seal where the recommended loading is 6.89×10^6 N/m² (1000 psi). If a contaminant becomes trapped between poppet and its seat and is not crushable, the torque limited actuator tool will release prior to reaching the designed stop position and without the valve stem

in its proper place the units are incapable of being disengaged. This prevents the uncoupling of the disconnects when the poppets are not completely sealed.

- *Sealing Features* - Since the FR/PID is designed for several different fluid systems, the best chemically inert sealing material is teflon. For this reason all static and dynamic seals in the FR/PID are teflon or use teflon as the base material.

Redundant seal techniques are incorporated at dynamic sealing locations and single seals are used at static sealing locations. The redundant seal locations include the shaft seals on the moveable spool, separation plane seals and the poppet seals. Two sets of double seals are used on the moveable spool and double seals on the separation plane, but the poppet utilizes metal-to-metal sealing for the redundancy in that area. The end caps use the standard MS33649 boss static seal.

The teflon seals have several different configurations. The separation plane seals are of the "omni-seal" type using a "rectangular" gland. The outer edge of the seal has a "bead" machined on to it that matches a machined recess in the outboard side of the gland. This provides seal retention when the disconnect halves are separated. The end caps use the "Raco" boss seals and the poppet uses a captured seal.

- *Coupling Feature* - The coupling feature consists of cam actuated clamp fingers that clasp the two disconnect halves together with a force of 3069 newtons (690 lbs). The cam is part of the handle that lays across the top of the disconnect units. The clamp fingers consist of a pivot point at one end and a clamp yoke at the other with the center section made up of an adjustment screw with Belleville washers. The initial setup of the clamp is accomplished by tilting the handle back 0.4 radians (24 degrees) and adjusting the clamp finger until both disconnect halves are in contact with each other. When the handle is positioned flat across the FR/PID, the Belleville washers are deflected .23 mm (.009 in.) of a possible .51 mm (.020 in.) resulting in the clamp force of 3069 newtons (690 lbs).
- *Foolproofing Technique* - To prevent the accidental disengagement of disconnect halves prior to fluid isolation, a foolproofing method is incorporated in the design. This consists of eccentric caps attached to the valve stems that coincide with slots in the coupling handle. When the disconnect halves are open, the eccentrics overlap the handle preventing its movement; likewise, when

GENERAL NOTES

1. BREAK ALL SHARP CORNERS
2. LUBRICATE THREADS WITH A DRY LUBRICANT TO PREVENT GALLING.
3. ALL SLIDING SURFACES OF POPPET DRIVE MECHANISM TO BE COATED WITH A LIGHT SILICONE GREASE.

TOOL REQUIREMENT

OPERATION: T-HANDLE TORQUE TOOL SET AT 15 IN-LB WITH A 3/16 HEX KEY TIP

MAINTENANCE: CRESCENT WRENCH WITH OPENING TO 1.00 INCH, STANDARD BLADE SCREWDRIVER, SET OF ALLEN WRENCHES, SNAP RING PLIERS

FLAGNOTES

1. GROOVE WIDTH TO BE SLIP FIT WITH -011 YOKE SPRING
2. ASSEMBLE UNIT WITHOUT -003 SPACER RING. POSITION TOP DEAD CENTER AND MEASURE HEIGHT DIFFERENCE BETWEEN FACE AND SEPARATION PLANE. THICKNESS OF -003 WILL BE DISTANCE PLUS .018.
3. ASSEMBLE UNIT WITHOUT -007 SPACER RING. POSITION TOP DEAD CENTER IN OPEN POSITION. MEASURE DISTANCE BETWEEN -008 AND BACK SURFACE OF -017 END PLUG. THICKNESS WILL BE THE MEASURED GAP PLUS .005.
4. MACHINE TO WITHIN A FEW THOUSANDTHS OF FINAL DIMENSION. TREAT TO ROCKWELL-C 60. FINISH GRIND TO DESIRED
5. PILOT DRILL #60 (.040 DIA) IN -015, TRANSFER HOLE TO VALVE WILL BE DRILLED AND REAMED FOR PRESS FIT OF 1/16 DIA D. PILOT HOLE IN -015 FOR SLIP FIT OVER PIN FOR INDEX
6. PILOT DRILL #43 (.089 DIA) IN -015, TRANSFER HOLE TO VALVE WILL BE TAPPED TO 4-40 THREAD. OPEN PILOT HOLE IN -015 BOLT CLEARANCE.
7. PASSIVATE ALL STAINLESS STEEL PARTS

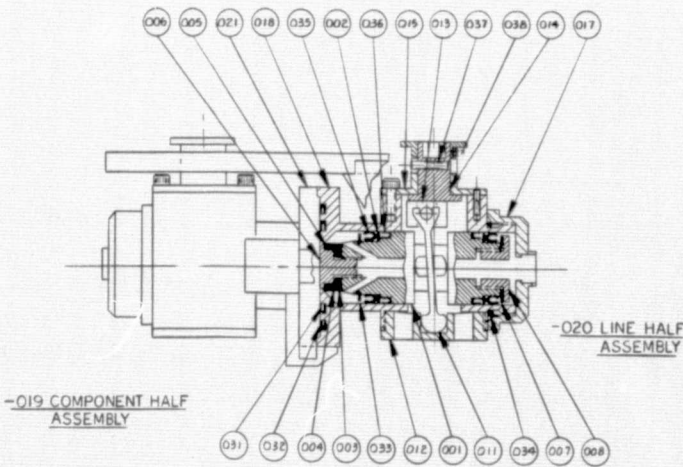
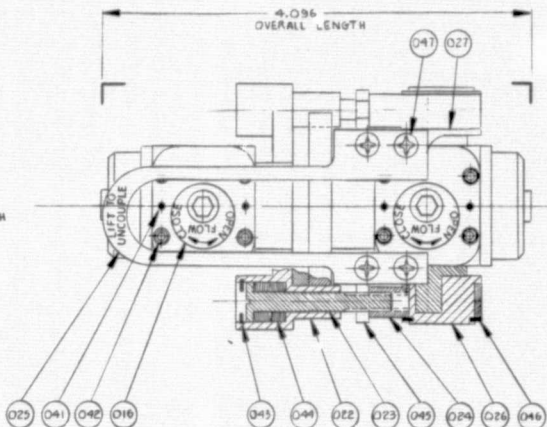
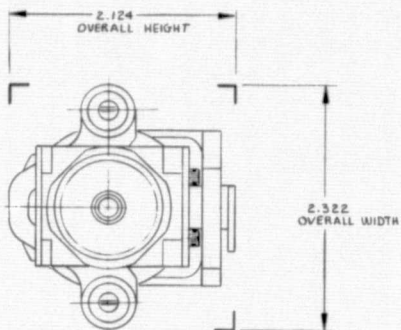

-009 POSITIVE ISOLATION DISCONNECT ASSEMBLY

Figure IV-4

4	047
2	048
2	045
2B	044
2	043
4-4	042
2 2	041
1 1	038
1 1	037
2 2	036
2 2	035
1 1	034
1 1	033
1	032
1	031
1	028
1	027
1	026
2	025
2	024
2	023
1	022
1 1	021
1 1	018
1 1	017
1 1	016
1 1	015
1 1	014
1 1	013
1 1	012
1 1	011
1 1	008
1 1	007
1 1	006
1 1	005
1 1	004
1 1	003
2 2	002
1 1	001
1	020
1	019
1	009

FOLDOUT FRAME

ORIGINAL PAGE IS OF POOR QUALITY

REV	DESCRIPTION	DATE	APPROVED
A	ADDED TOOL REQUIREMENT NOTES TO NOTE SEC OF DRAWING	77 Jan 11 1-13-77	F. WATTS

GENERAL NOTES

1. MAKE ALL SHARP CORNERS
 2. LUBRICATE THREADS WITH A DRY LUBRICANT TO PREVENT GALLING.
 3. LUBRICATE SLIDING SURFACES OF POPPET DRIVE MECHANISM TO BE MATED WITH A LIGHT SILICONE GREASE.

TOOL REQUIREMENT

OPERATION: T-HANDLE TORQUE TOOL SET AT 15 IN-LB WITH A 3/16 HEX KEY TIP
 MAINTENANCE: CRESCENT WRENCH WITH OPENING TO 1.00 INCH, STANDARD BLADE SCREWDRIVER, SET OF ALLEN WRENCHES, SNAP RING PLIERS

FLAGNOTES

- 1. GROOVE WIDTH TO BE SLIP FIT WITH -011 YOKE SPRING RUBBING BLOCKS.
- 2. ASSEMBLE UNIT WITHOUT -003 SPACER RING. POSITION CAM DRIVER IN TOP DEAD CENTER AND MEASURE HEIGHT DIFFERENCE BETWEEN POPPET FACE AND SEPARATION PLANE. THICKNESS OF -003 WILL BE THE MEASURED DISTANCE PLUS .018.
- 3. ASSEMBLE UNIT WITHOUT -007 SPACER RING. POSITION CAM DRIVER IN TOP DEAD CENTER IN OPEN POSITION. MEASURE DISTANCE BETWEEN -008 AND BACK SURFACE OF -017 END PLUG. THICKNESS OF -007 WILL BE THE MEASURED GAP PLUS .005.
- 4. MACHINE TO WITHIN A FEW THOUSANDTHS OF FINAL DIMENSIONS. HEAT TREAT TO ROCKWELL-C 60. FINISH GRIND TO DESIRED FINAL DIMENSIONS.
- 5. PILOT DRILL #60 (.040 DIA) IN -015, TRANSFER HOLE TO VALVE BODY WHICH WILL BE DRILLED AND REAMED FOR PRESS FIT OF 1/16 DIA DOWEL PIN. OPEN PILOT HOLE IN -015 FOR SLIP FIT OVER PIN FOR INDEXING.
- 6. PILOT DRILL #43 (.089 DIA) IN -015, TRANSFER HOLE TO VALVE BODY WHICH WILL BE TAPPED TO 4-40 THREAD. OPEN PILOT HOLE IN -015 TO .125 DIA FOR BOLT CLEARANCE.
- 7. PASSIVATE ALL STAINLESS STEEL PARTS.

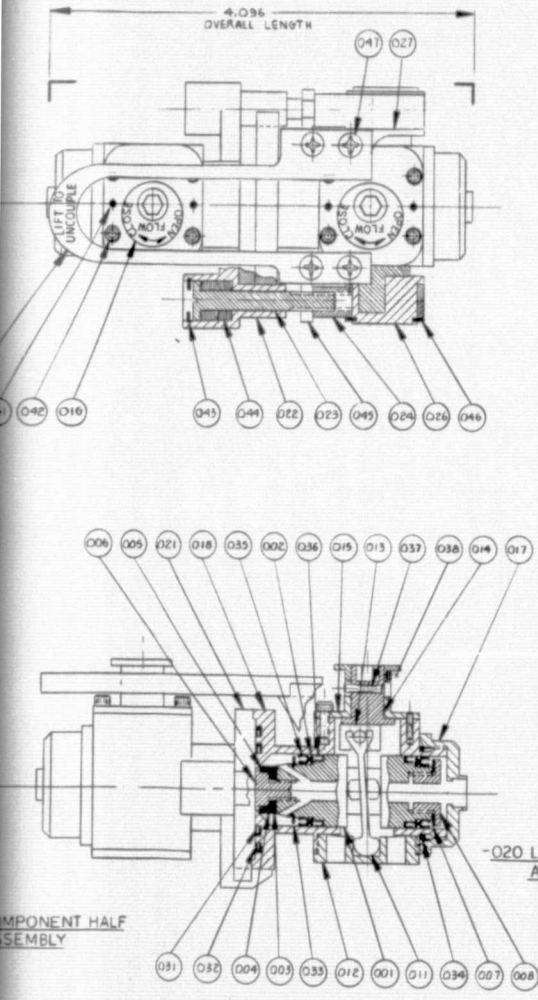
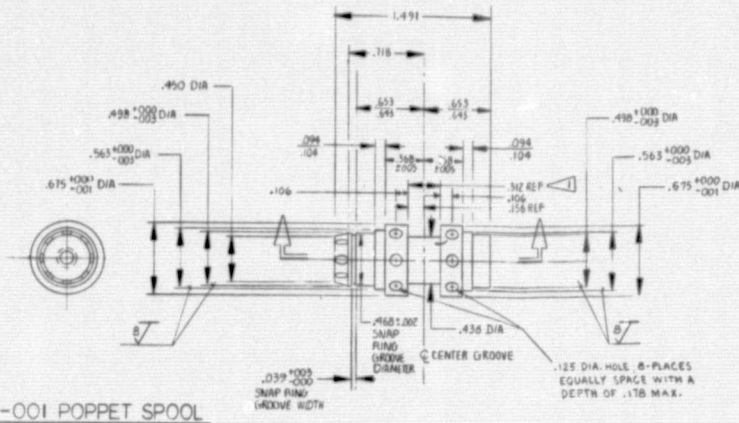

Figure IV-4 FR/PID Detail Design Drawings

QTY	PART NO	DESCRIPTION	STOCK SIZE	MATERIAL OR FINISH	MATERIAL SPECIFICATION	REVISIONS
4	047	FLT HD SCREEN	1007-4-40TB X 1/4		MS 24093-2	
2	046	RETAINING RING	3100-02		TRUARC	
2	045	SAMB NUT	10-31 TMD		PIC # Y8-10	
28	044	BELLEVILLE WASHERS	3/16 ID X 3/8 O.D.		PIC # D6-E.B	
2	043	RETAINING RING	N 5000-37		TRUARC	
4	042	SOC HD CAP SCREW	4-40TB X 1/4 LWB		PIC # 15-4-T	
2	041	DOWEL PIN	1/16 DIA X 3/16 LWB		PIC # D15-107	
1	038	SOC HD SET SCREW	2-56 TMD X 1/4 LG		SDP# SMT-275602	
1	037	DOWEL PIN	3/16 DIA X 3/16 LG		PIC # D16-312	
2	036	DYNAMIC SEAL	SR-015-12-1		FLUOROCARBON	
2	035	DYNAMIC SEAL	SR-112-12-1		FLUOROCARBON	
1	034	BOSS SEAL	WACO 10061-806		FLUOROCARBON	
1	033	RETAINING RING	3100-30		TRUARC	
1	032	FACE SEAL	AR40736		FLUOROCARBON	
1	031	FACE SEAL	AR40755		FLUOROCARBON	
1	028	PROTECTIVE CAP	1340M RDX 1/2 LG		316 STAINLESS STL	
1	027(OPP-026)	PIVOT LEG	1213W 2-2 1/2 PLATE		316 STAINLESS STL	
1	026	PIVOT LEG	11 x 13M 2 1/2 PLT		316 STAINLESS STL	
1	025	COUPLER HANDLE	1/4 x 1 1/4 x 3/8 PLT		316 STAINLESS STL	
2	024	CLAMP COLLAR	1/2 x 1 x 1 1/2 BAR		316 STAINLESS STL	
2	023	CLAMP ADD SCREW	1/2 DIA X 1 3/4 LG		316 STAINLESS STL	
1	022	CLAMP BAR	1/4 x 1 1/2 x 2 3/4		316 STAINLESS STL	
1	021	VALVE BODY	2 x 2 x 2 1/4 BAR		316 STAINLESS STL	
1	018	VALVE BODY	2 1/2 x 2 1/4 x 2 1/4 BAR		316 STAINLESS STL	
1	017	END PLUG	1/2 x 1 1/2 x 1/4 PLATE		316L STAINLESS STL	
1	016	POSITION INDICATOR	1 DIA RD X 1/4 LG		316 STAINLESS STL	
1	015	STEM RETAINER	3/8 x 1 1/4 x 1/2 PLATE		316 STAINLESS STL	
1	014	CAM STEM	3/8 DIA RD X 1/4 LG		4340 STEEL	
1	013	DRIVE YOKE	1/2 x 3/4 x 1		316 STAINLESS STL	
1	012	BOTTOM PLUG	1/2 x 1/4 x 1/4 PLATE		316 STAINLESS STL	
1	011	YOKE SPRING	1/2 x 1 1/2 BAR		4340 STEEL	
1	008	POPPET END CAP	3/8 DIA RD X 3/8 LG		316 STAINLESS STL	
1	007	SPACER RING	1/8 x 1 1/2 SHT		316 STAINLESS STL	
1	006	POPPET END CAP	3/8 DIA RD X 3/8 LG		316 STAINLESS STL	
1	005	SOCKET	1/4 DIA RD X 1/2 LG		TEFLON	
1	004	RETAINER RING	1/8 x 3/4 x 3/8 SHT		316 STAINLESS STL	
1	003	SCALER RING	1/8 x 3/4 x 3/8 SHT		316 STAINLESS STL	
2	002	RETAINING RING	1/8 x 1 1/2 SHT		316 STAINLESS STL	
1	001	POPPET SPOOL	3/8 DIA RD X 1 1/4 LG		316 STAINLESS STL	
1	020	LINE HALF ASSEMBLY				
1	019	COMPONENT HALF ASSEMBLY				
1	009	P.T.D. ASSEMBLY				

-009 POSITIVE ISOLATION DISCONNECT ASSEMBLY

APPROVED BY: [Signature] DATE: 3-9-76 F. JONKOWICZ	MARTIN MARETTA CORPORATION 100 27th St. (2nd Floor) Garden City, NY 11530
PART NO: 04236 REV: E DATE: 1-13-77	TITLE: POSITIVE ISOLATION DISCONNECT RES 3157000
EFFECTIVE ON: [Blank] DESIGNED BY: [Blank] CHECKED BY: [Blank] DRAWN BY: [Blank]	SHEET: 2/1 TOTAL SHEETS: 4



-001 POPPET SPOOL

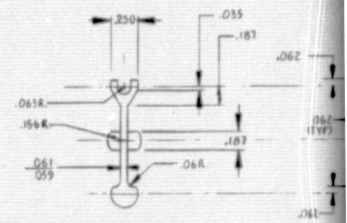

-011 YOKE SPRING

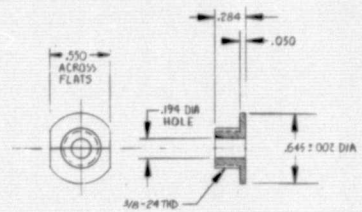
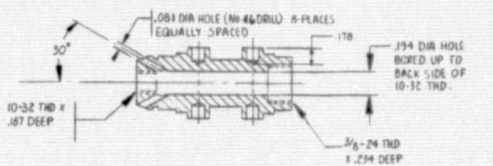

-008 POPPET END CAP

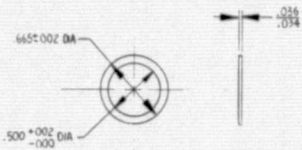

-002 RETAINING RING

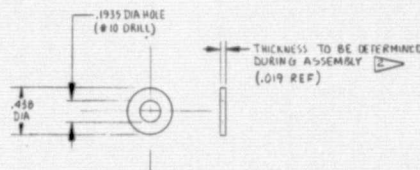

-003 SPACER RING

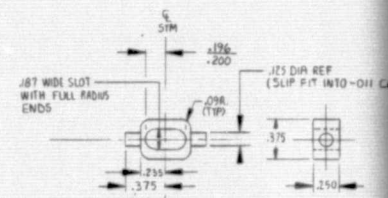

-013 YOKE

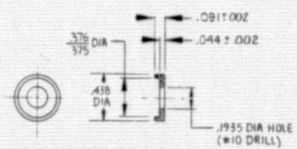

-004 RETAINER RING

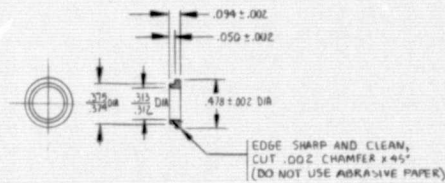

-005 POPPET SEAL

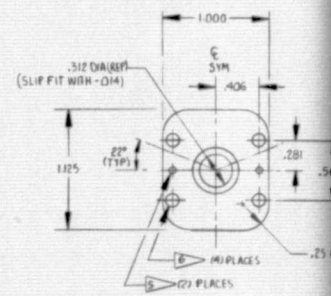

-015 STEM RING

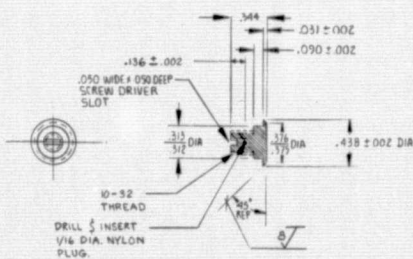

-006 POPPET FWD CAP

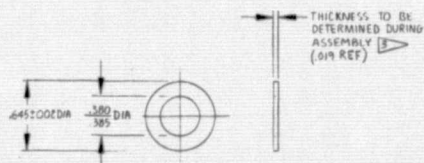

-007 SPACER RING

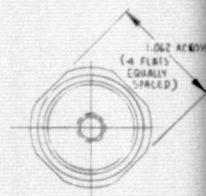

-017 END PLUG

REVISIONS		
NO.	DATE	DESCRIPTION
A		PART NO. - 001 1) ADDED .125 DIA HOLES 14 PLACES (LISTENING HOLES) 2) .078 DIA HOLE CHANGED TO .081 AND NO SO DRILL CHANGED TO NO 46 PART NO. - 003 1) ADDED REF. DIM. OF .019 PART NO. - 004 1) ADDED PLUG AND DEM. OF 156 R.002 PART NO. - 007 1) ADDED RES. DEM. OF .019 PART NO. - 013 1) CHANGED & SYM DEM FROM .127 TO .194 / 200 PART NO. - 014 1) ADDED 1/8 DIA X 1/2 LONG LISTENING HOLE CHANGED .062 BETWEEN & TO .100

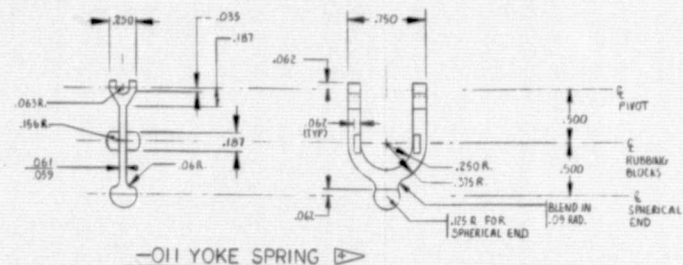
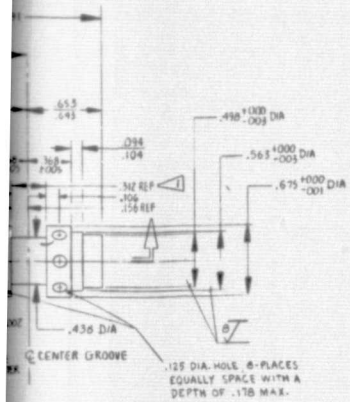

-011 YOKE SPRING

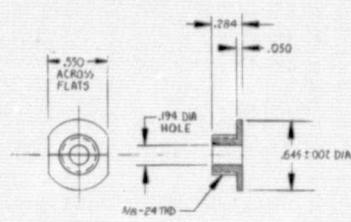
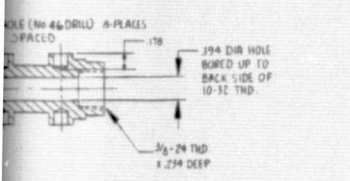

-008 POPPET END CAP

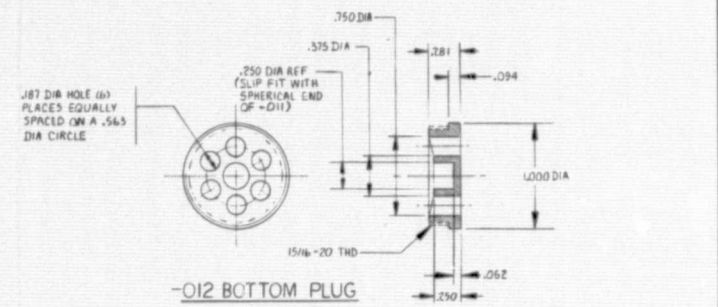

-012 BOTTOM PLUG

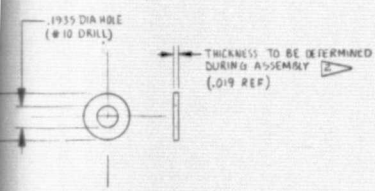

-003 SPACER RING

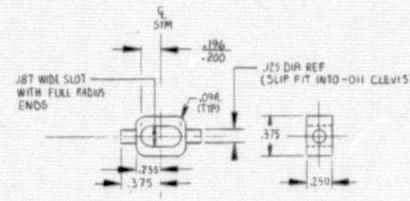

-013 YOKE

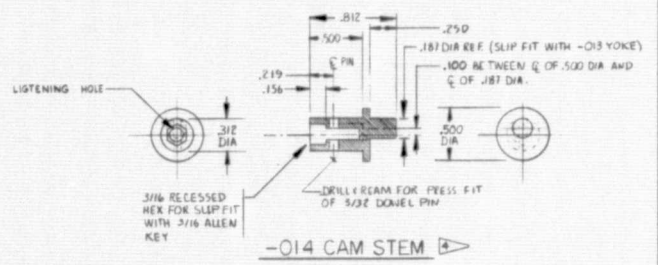

-014 CAM STEM

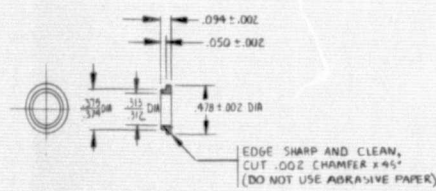

-005 POPPET SEAL

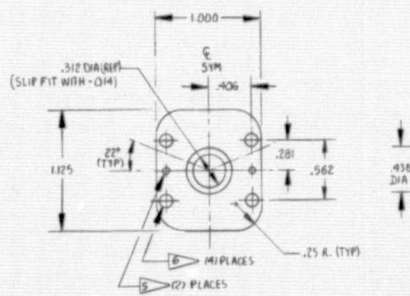

-015 STEM RETAINER

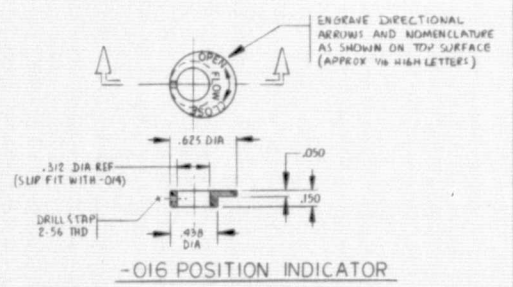

-016 POSITION INDICATOR

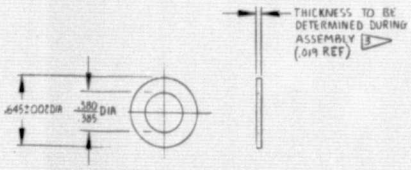

-007 SPACER RING

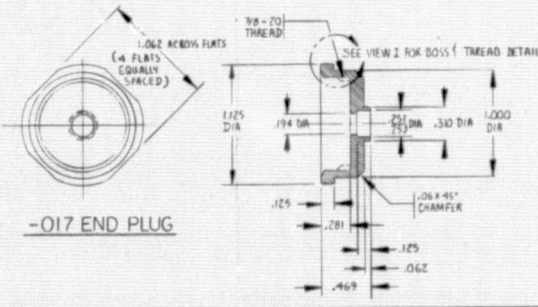

-017 END PLUG

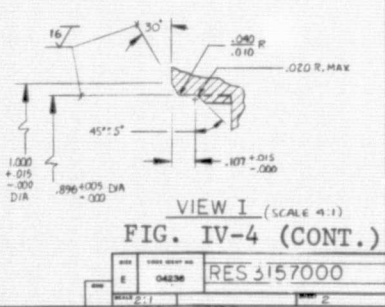
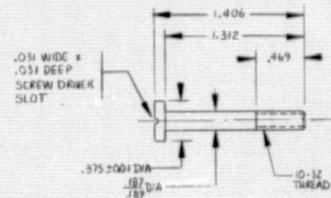
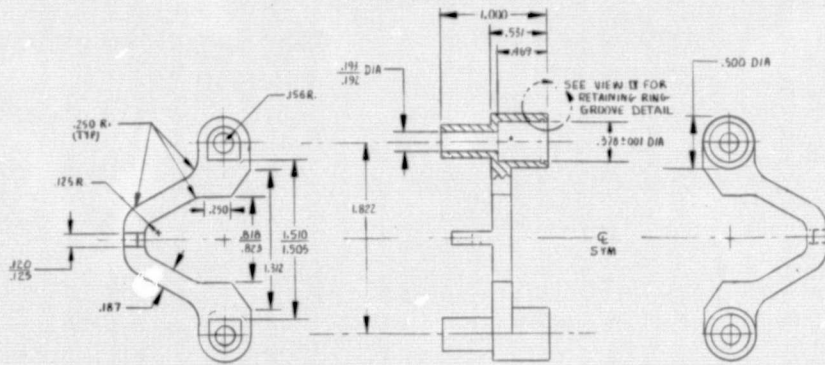

FIG. IV-4 (CONT.)

NO.	DATE	REVISED
E	04296	RES 157000

ORIGINAL PAGE IS OF POOR QUALITY



-023 CLAMP ADJ. SCREW

-022 CLAMP BAR

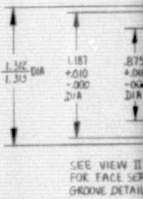
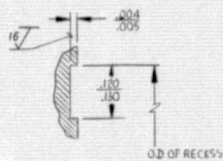
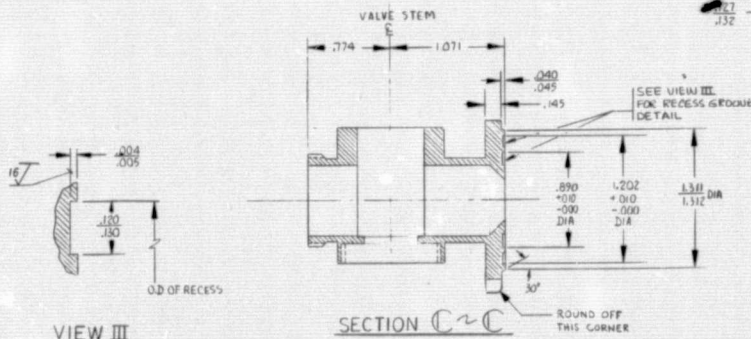
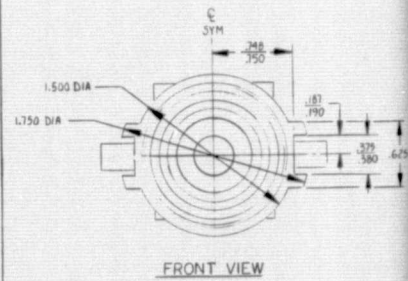
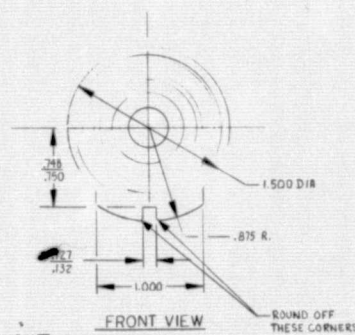
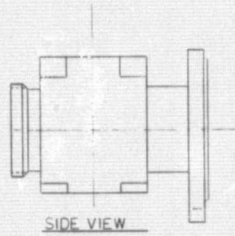
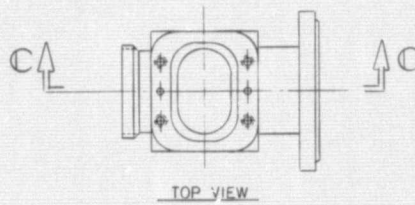
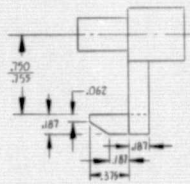
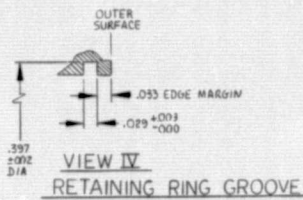

SEE VIEW II FOR FACE SCAL GROOVE DETAIL

-021 VALVE BODY

THIS DETAIL IS IDENTICAL TO -018 EXCEPT AT THE FRONT FLANGE, AND THE HANDLE PINOT BOSSES ARE REMOVED FROM THE -021.

-018 VALVE

ORIGINAL PAGE IS OF POOR QUALITY

FOLDOUT FRAME

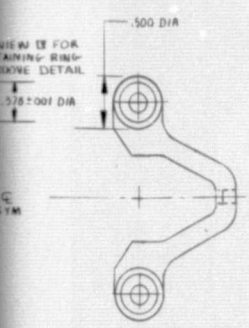

-022 CLAMP BAR

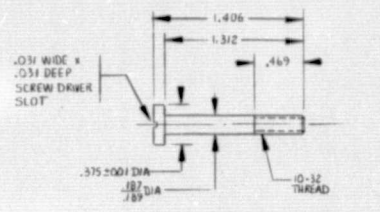

-023 CLAMP ADJ. SCREW

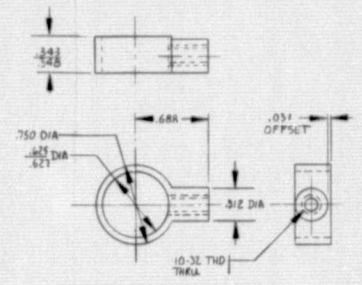

-024 CLAMP COLLAR

REV	DATE	DESCRIPTION	BY	APPROV
A		ADD ADDITIONAL 1/8 HOLES TO SEC. A-A SIDE & TOP VIEWS AND SEC. B-B OF PART NO -018	77 Jan 53	F. WATTS
		ADD .118 TO CORNERS OF SEC. A-A TOP VIEW OF PART NO -018	77 Jan 53	
		ADD WEIGHT REDUCING CUTS TO SIDE AND BACK VIEW OF SEC. A-A OF PART NO -018	77 Jan 53	
		ADD RADIUS TO CORNERS OF SEC. C-C OF FRONT VIEW OF PART NO -021	77 Jan 53	G. Blanton 1-13-77

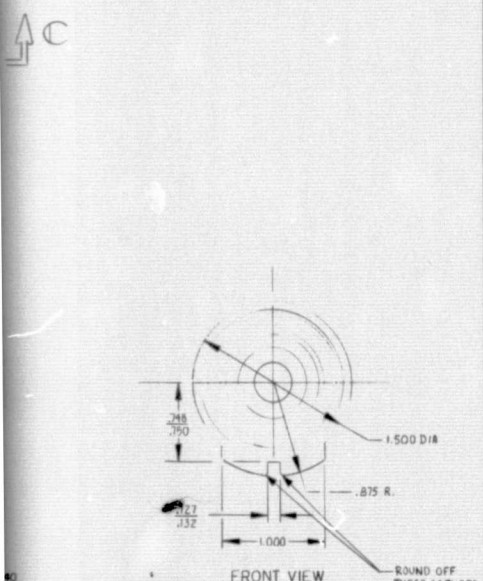

-021 VALVE BODY
THIS DETAIL IS IDENTICAL TO -018 EXCEPT AT THE FRONT FLANGE, AND THE HANDLE PIVOT BOSSES ARE REMOVED FROM THE -021.

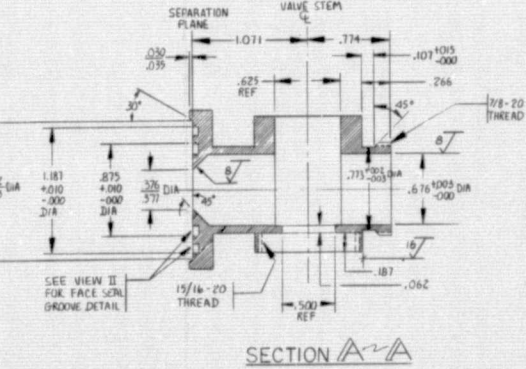
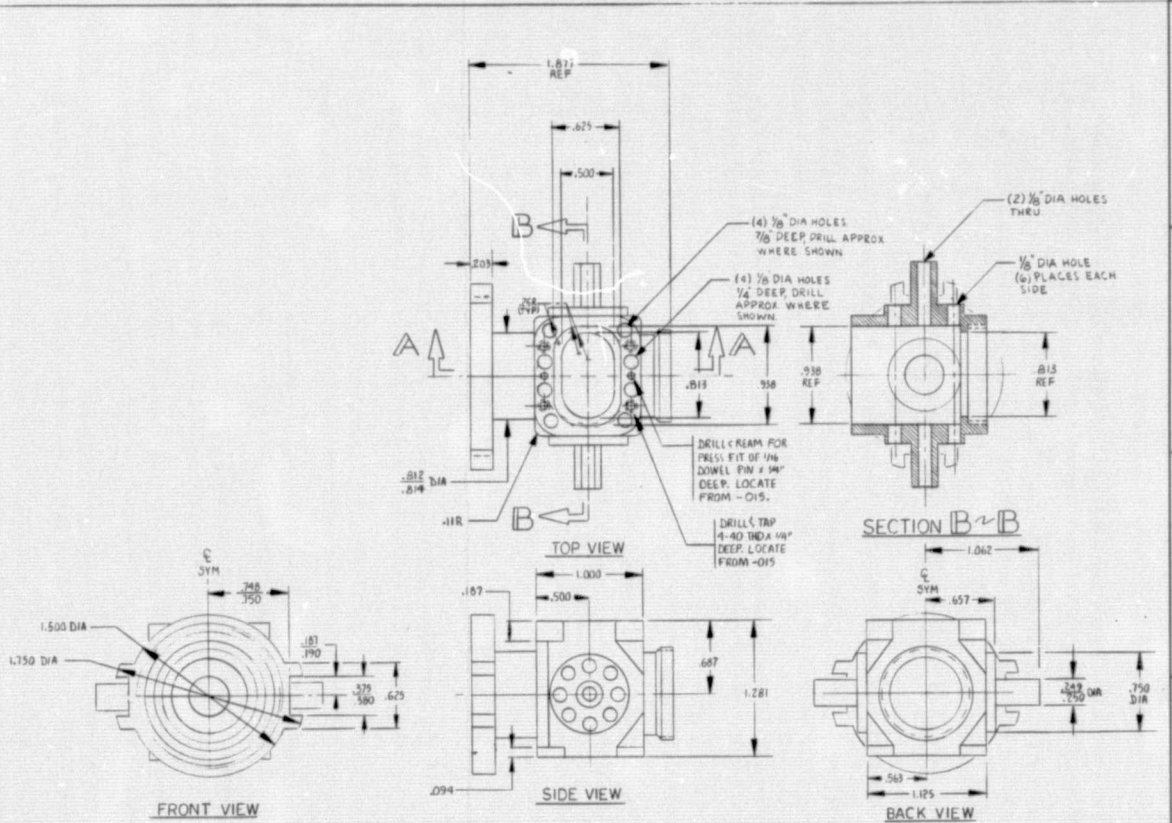

-018 VALVE BODY

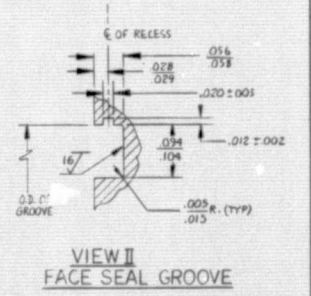

VIEW II
FACE SEAL GROOVE

FIG. IV-4 (CONT.)

REV	DATE	DESCRIPTION
E	04230	RES 3157000

COLDOUT FRAME

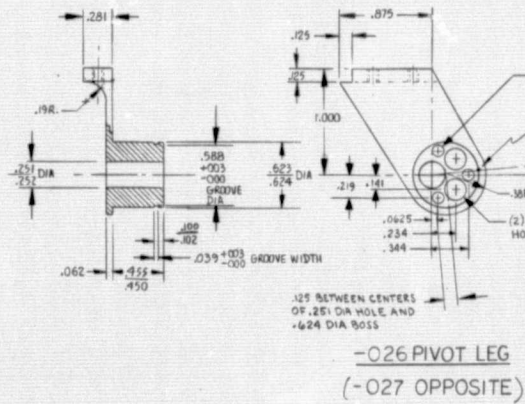
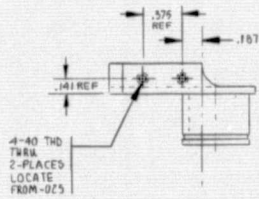
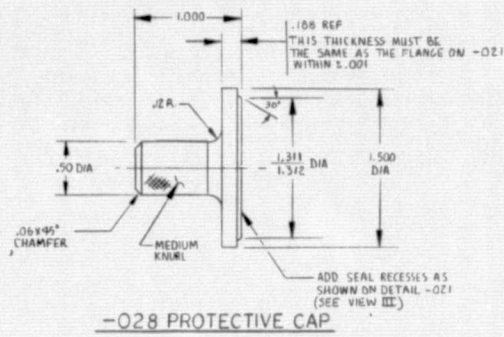

ENGRAVE NOMENCLATURE AS SHOWN ON TOP SURFACE WITH APPROX 1/16 HIGH LETTERS

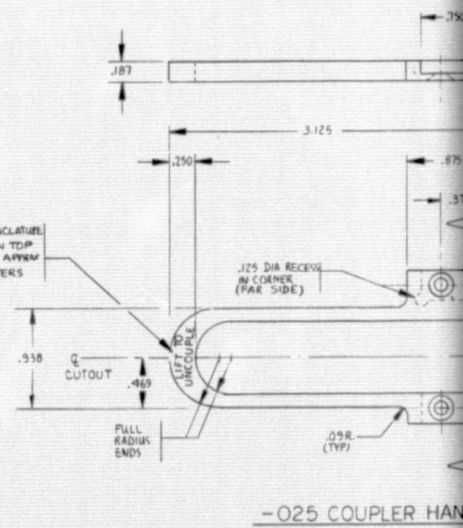

ORIGINAL PAGE IS OF POOR QUALITY

REVISIONS			
NO.	DATE	DESCRIPTION	BY
A		ADD (3) 3/32" + (2) 9/16" HOLES TO PART NO. -026	F. WATTS
			77 JAN 13 1955

IF THICKNESS MUST BE SAME AS THE FLANGE ON -021 ±.001



SEAL RECESSES AS SHOWN ON DETAIL -071 (SEE VIEW III)

3/4" DIA

ENTRIC

HORIZONTAL DATUM PLANE PASSING THRU CENTER OF .251 DIA HOLE

LINE PASSING THRU HIGH POINT ON CAM AND CENTER OF .251 DIA HOLE

ENGRAVE NOMENCLATURE AS SHOWN ON TOP SURFACE WITH APPROX 3/16 HIGH LETTERS

.25 DIA RECESS IN CORNER (FAR SIDE)

DRILL 5/8 DIA HOLE 4-PLACES, COUNTERSINK 100° TO .235 DIA

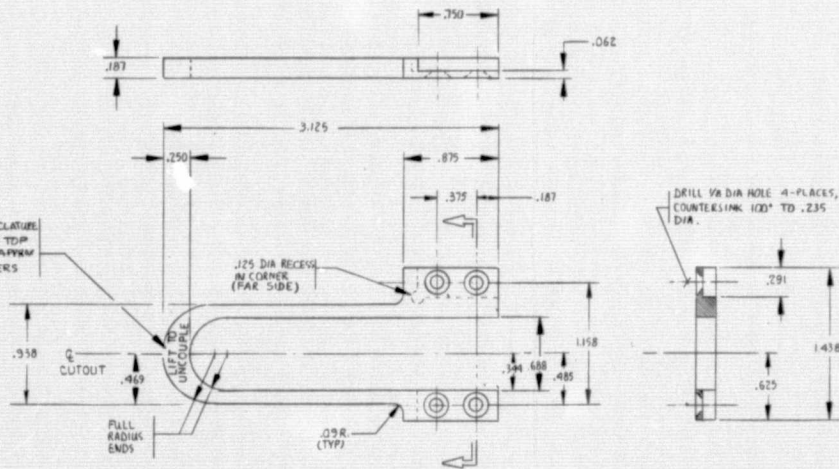

-025 COUPLER HANDLE

FIG. IV-4 (CONT.)

REV	DATE	BY	APP'D
E	04230		
RES3157000			

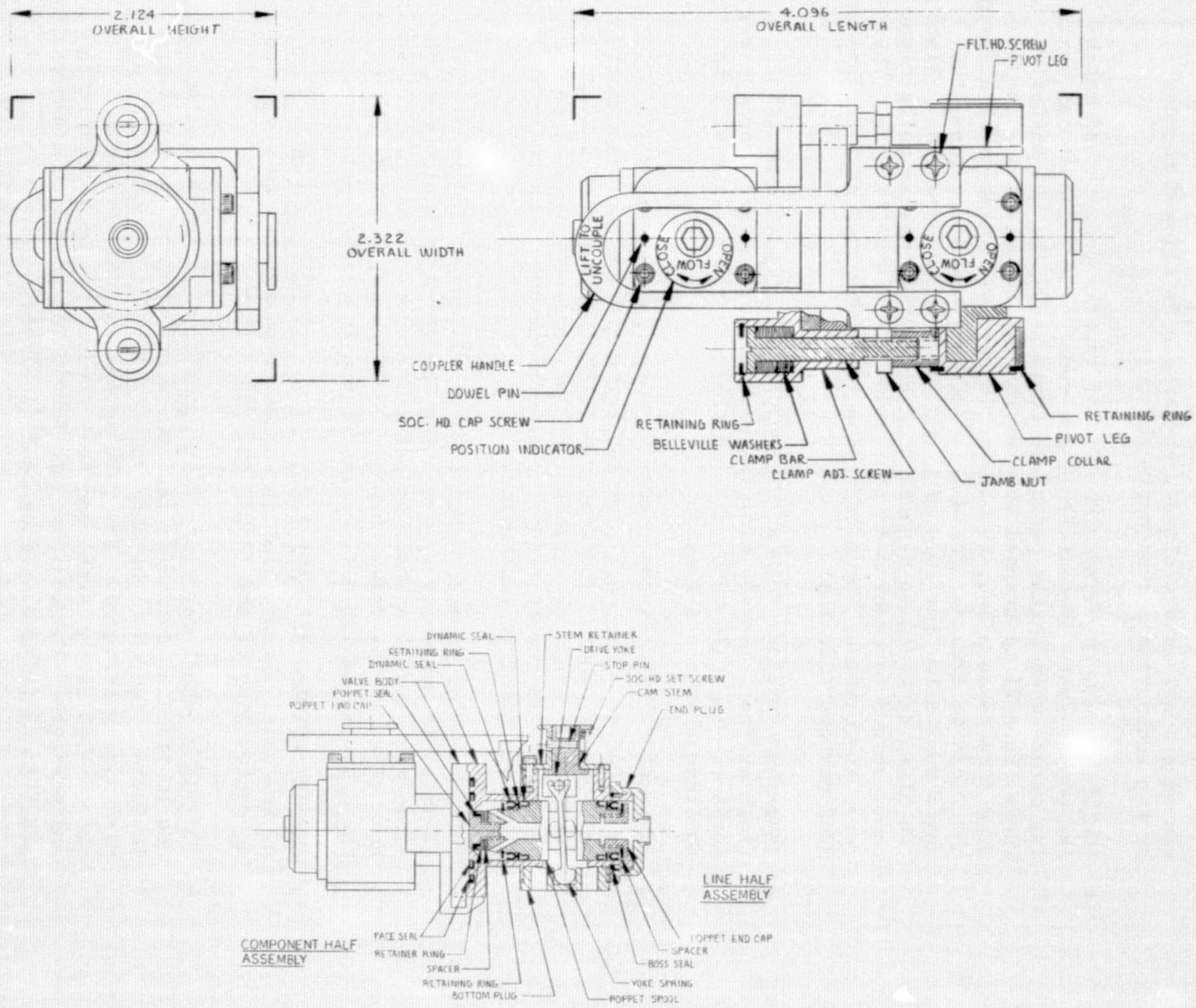

Figure IV-5 FR/PID Cross-Section View and Top View

disconnect halves are closed, the handle is allowed to pass by the eccentrics and uncouple the unit.

- *Fluid Compression/Expansion* - Use of tapered poppets and matching poppet seats prevent fluid compression or expansion as sealing occurs when mating parts are contacted. For the situation where Freon-21 is trapped between the disconnects and a temperature rise takes place, the design incorporates a means of allowing the fluid to expand. For a 44°K (80°F) temperature rise, the units must allow for .010 mm (.0004 in.) axial expansion. Since the clamping force is dependent on Belleville washer deflection, the required movement adds that amount to the deflection. Therefore, the clamping force increases from 3069 newtons (690 lbs) to 3202 newtons (720 lbs).
- *Interface Spillage Volume* - The poppet and poppet seat provide a flush surface, thereby minimizing possible leakage to only a wet surface. The thin water film on the separation plane will be retained by surface tension.
- *Separation Plane Lateral Movement* - The design provides a 1.143 mm (0.045 in.) concentric offset for centering one disconnect half to the other. Therefore, a lateral movement of 1.27 mm (0.050 in.) would be satisfactory for component removal as compared to disconnects requiring lateral movements up to 19 mm (.75 in.) prior to separation.
- *Metal-to-Metal Contact* - Metal-to-metal contact in the fluid cavities is prevented by isolating the drive mechanism from the fluid with use of a spool poppet. The spool rides on shaft seals that slide in the valve housing. Surfaces with metal contact in the drive mechanism will be lubricated to resist wear.
- *Operational Access* - All functions can be performed on one side of the unit, thereby limiting access requirements to a side normal to center line of the FR/PID and fluid flow.
- *Materials* - Most parts are fabricated from 316 stainless steel due to its high corrosion resistance and strength properties. To further increase the materials resistance to corrosion, all parts are passivated. The yoke spring and cam are made out of 4340 carbon steel and heat treated for wear resistance and strength. The end caps are fabricated from 316L stainless steel to facilitate welding to fluid lines.

- *Weight and Dimensional Criteria* - A complete disconnect unit with both halves and coupling mechanism weighs .61 kilograms (1.343 lbs). The complete FR/PID coupled has overall dimensions of 58.9 mm (2.32 in.) in width by 53.8 mm (2.12 in.) in height by 103.9 mm (4.09 in.) in length.
- *Fluid Compatibility* - The units are compatible with operational fluids of high purity water, Freon-21, sweat and respiratory vapor, urine, coolant water, and nitrogen gas for periods up to 10 years.
- *Leakage Limitations* - The FR/PID is capable of meeting an external and internal zero leakage requirement of 1×10^{-6} scc/sec utilizing helium gas.
- *Operational Life Expectancy* - The PID is designed for an operational life expectancy of 5000 cycles. Each cycle consists of isolate-disconnect-connect-flow.
- *Tool Requirement* - For normal FR/PID operation (which includes closing both disconnects, uncoupling, component replacement, coupling disconnects together, open disconnects), only a 4.75 mm (3/16 in.) Allen hex key adapted to a T-handle torque tool is required. For breakdown of the FR/PID, the required tools include a crescent wrench with an opening of 38.1 mm (1.50 in.), standard blade screw driver, and a set of Allen wrenches.

D. EVALUATION OF CONCEPT FOR APPLICATION TO LARGER SIZES

The FR/PID as shown in Martin Marietta Corporation's drawing No. RES3157000 is designed for 6.35 mm (.25 in.) line fluid systems. For larger lines, the forward end of the poppet spool would have to be increased to accommodate the increased flow area requirement. Also, the length of the poppet spool would have to be increased as the flow ports around the poppet are made larger. The outside diameter of the poppet spool can remain the same since the center bore can be enlarged to match the larger tube size. Overall height and width for a 12.7 mm (.50 in.) line unit would remain the same as the 6.35 (.25 in.) unit, but the overall length would approach 114.3 mm (4.5 in.) in length which is 6.35 mm (.25 in.) longer per disconnect half. The weight increase from a 6.35 mm (.25 in.) unit to a 12.7 mm (.50 in.) unit is approximately five percent.

V. FLIGHT REPRESENTATIVE PID DEVELOPMENT

A. PURPOSE AND SCOPE

The purpose of this task was to fabricate one 6.35 mm (1/4 in.) FR/PID and perform testing to assure that the contract SOW requirements were satisfied. The testing also was to demonstrate that the design improvements developed to resolve the contract NAS9-14376 problem areas were positive solutions.

B. FABRICATION OF FLIGHT REPRESENTATIVE PID

The FR/PID assembly was fabricated in Martin Marietta's Engineering Model Shop from the RES3157000 detail design drawings shown in Figure IV-4. Program personnel prepared and released procurement requirements for commercial components and material per the drawing bill of materials. An assembled FR/PID with both halves and coupling mechanism weighed .61 kilograms (1.343 lbs.). The complete FR/PID has overall dimensions of 58.9 mm (2.32 in.) in width, 53.8 mm (2.12 in.) in height, and 103.9 mm (4.09 in.) in length.

Figure V-1 shows the assembled FR/PID with both halves coupled together by the coupling mechanism. The tubing attached to each end is not a part of the FR/PID, but was utilized in the developmental testing. Figure V-2 shows a top view of the FR/PID with the poppet stem foolproofing cams aligned with the coupling mechanism handle slots. In this condition, the internal poppets are closed and the handle can be lifted to uncouple the two halves as shown in Figure V-3.

Figure V-4 shows the two halves separated. The half with the coupling mechanism is considered the line half and the other half is considered the component half. The dual face seals in the line half and the recessed mating partial glands in the component face are visible in this figure. Figure V-5 shows the component half FR/PID with the internal poppet opened. The outer flange is notched as shown at the bottom of this figure for quick alignment purposes between the two halves. The poppet is opened by turning the poppet valve stem 3.14 radians (180°) in the direction of the arrow marked "open".

Figure V-6 shows the line half FR/PID with the protection end cap. The cap protects the face seals during periods when the component

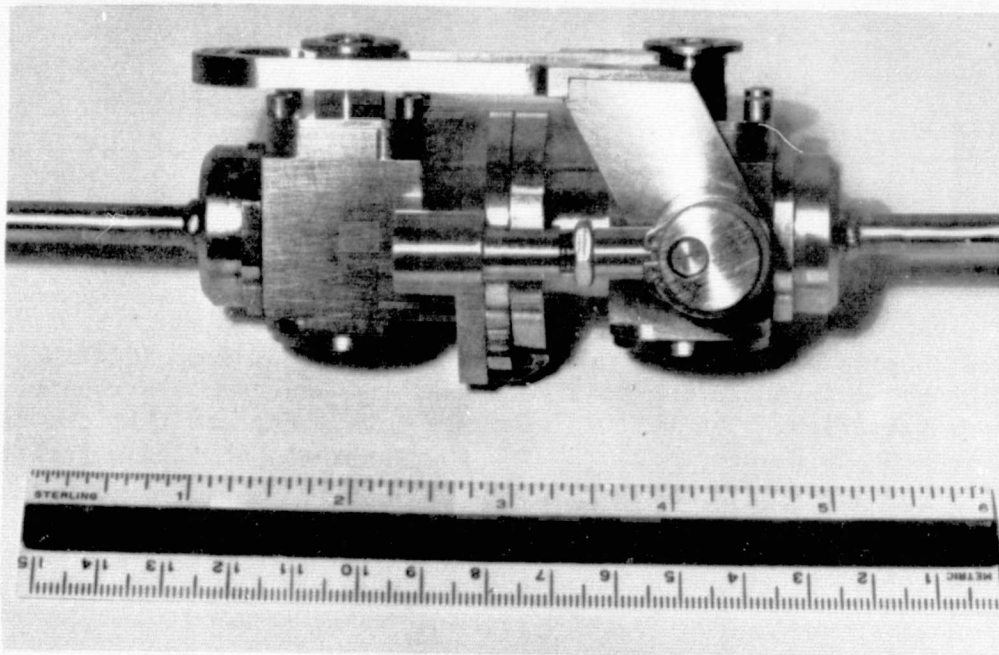

Figure V-1 Assembled FR/PID (Side View)

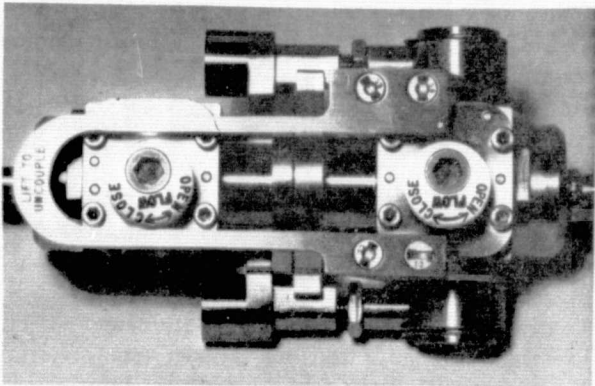

Figure V-2 Assembled FR/PID (Top View)

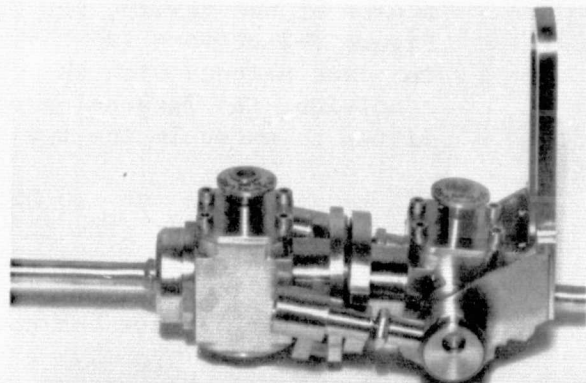

Figure V-3 FR/PID Coupling Mechanism in Released Position

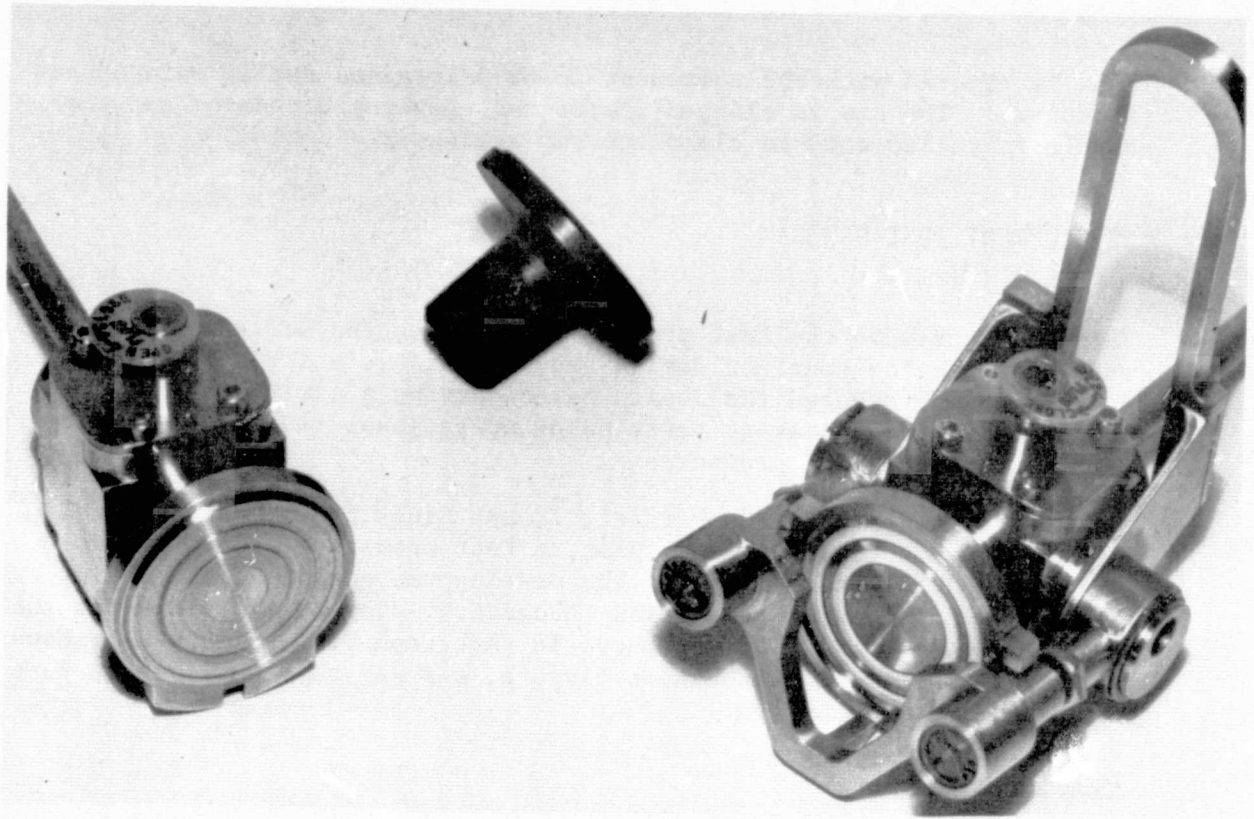

Figure V-4 FR/PID Halves Separated

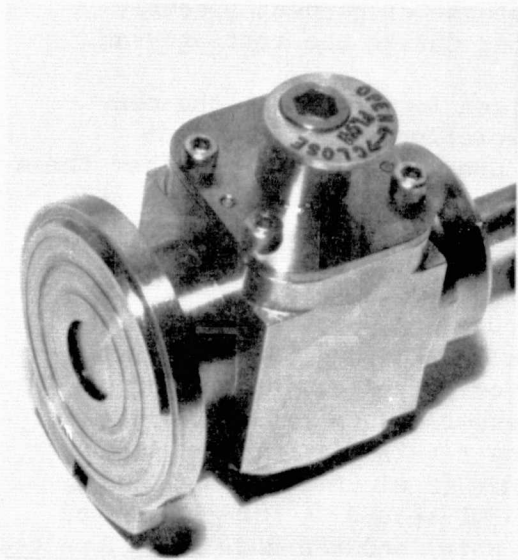

Figure V-5 FR/PID Component Half with Poppet Opened

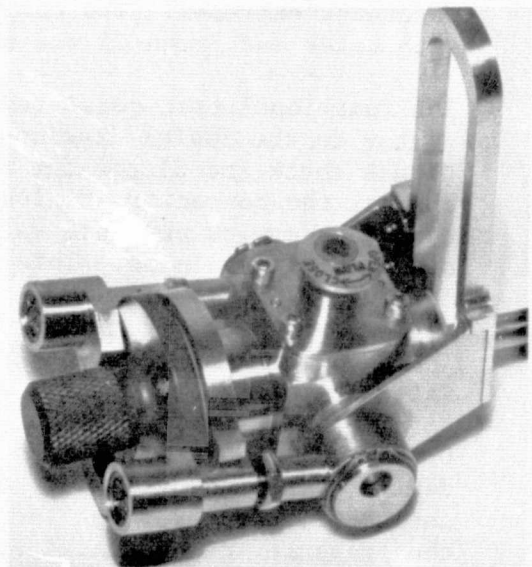

Figure V-6 Line Half FR/PID with Protective Cap

half is removed with the component to be maintained during maintenance functions. The cap is slipped inside the coupling mechanism and the handle is pulled down to clamp the cap against the seals.

C. DEVELOPMENT TEST PROGRAM

This task provided the test program to evaluate the design improvements and to assure the contract design requirements were satisfied. The test program evaluated the design by conducting a series of tests including life and leakage tests using operational fluids at specified temperatures and pressures.

A Master Test Plan, DRL Number T-1277, DRL Line Item 3, was prepared and submitted. From this test plan, a test procedure identified as Procedure H40691 was prepared. The testing was performed in Martin Marietta's Engineering Propulsion Laboratory. The test article was the 6.35 mm (1/4 in.) FR/PID fabricated in paragraph V.B. Figure V-7 shows the FR/PID installed in the test fixture, and Figure V-8 shows the test setup and instrumentation.

Test Description

The test program for the Flight Representative Positive Isolation Disconnect consisted of proof pressure, fluid compatibility, leakage, operational life cycle, compressibility, pressure drop, and liquid loss tests using fluids at their pressure and temperature parameter extremes. The compatibility of the disconnect assembly with water and Freon-21 was also evaluated during the test program.

The functional test consisted of a physical inspection of the connector to the design drawings. This inspection involved dimensional check and disconnect moving part operational check. After these checks, the connector was installed in the test fixture and was cycled under low pressure water $34.5 \times 10^3 \text{ N/m}^2$ (5 psig) to verify operational readiness. This involved a mate-demate operational check.

The proof pressure test was performed to demonstrate the structural integrity of the disconnect assembly prior to performing any other testing. For this test the unit was pressurized to 2.59×10^6 plus 0 minus $4.14 \times 10^4 \text{ N/m}^2$ (375 plus 0 minus 6 psig) (1.5 times the design operating pressure) for 300 seconds (5 minutes) with GN_2 at ambient temperature. At the end of the 300 second (5 minute) period the pressure was decreased to 0 N/m^2 (0 psig) and the unit was inspected

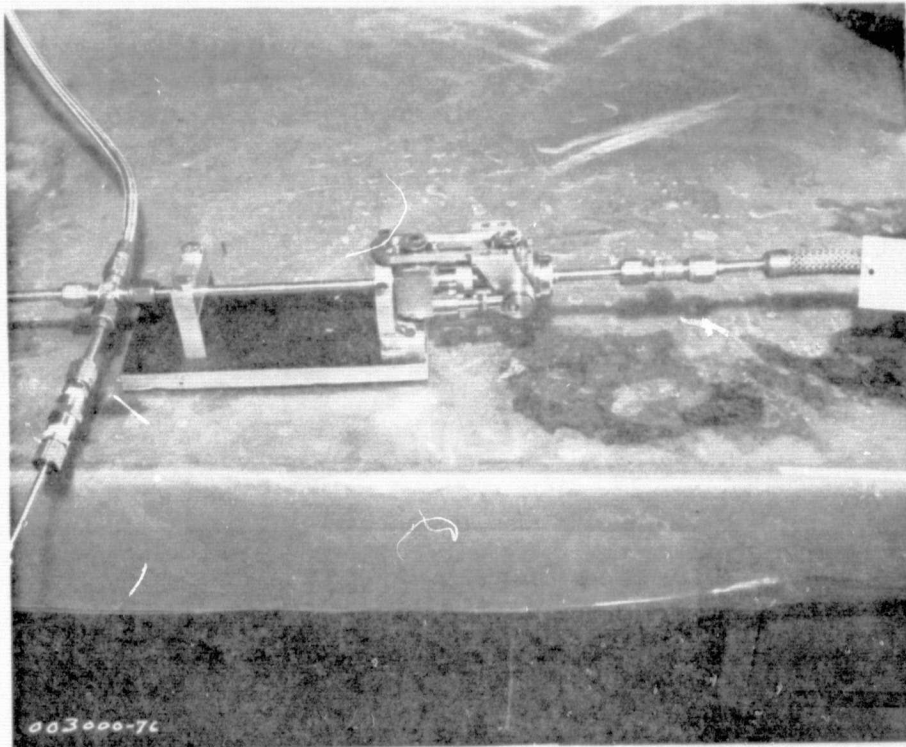

Figure V-7 FR/PID Installed in Test Facility

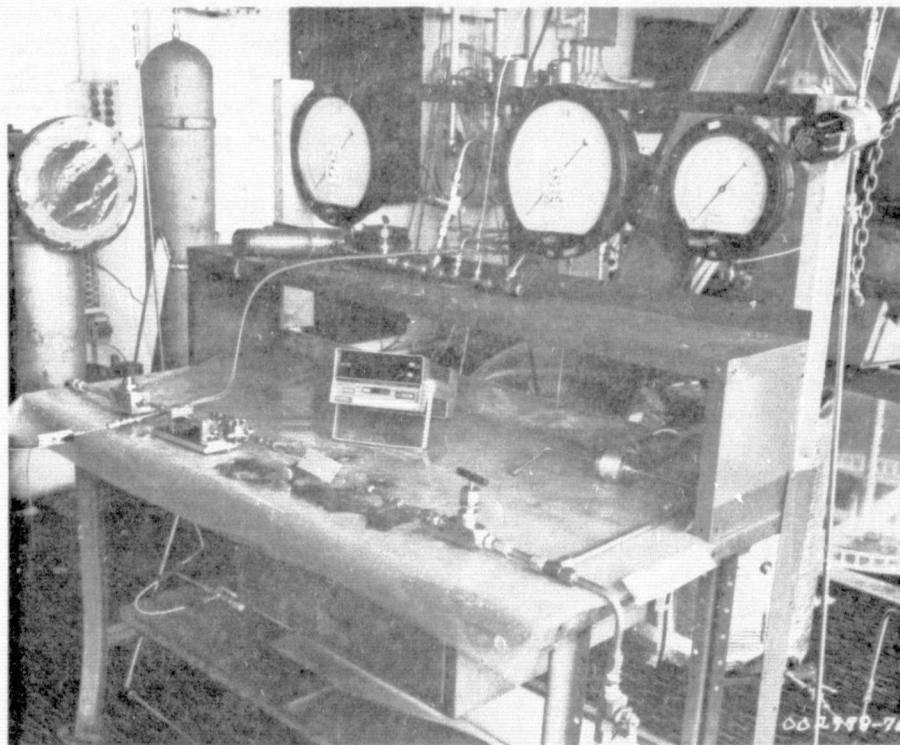

Figure V-8 FR/PID Test Setup and Instrumentation

ORIGINAL PAGE IS
OF POOR QUALITY

for any signs of permanent deformation or degradation in its operational capability. This test was performed with the isolation valves open and the unit connected and repeated on each half of the disconnected unit with the isolation valves closed (see Figures V-9 and V-10).

Internal and external leak tests were performed at intervals during the operational life cycle testing as an indication of performance degradation. For the internal leak checks, water and GN₂ were used as the test fluids. As the system was pressurized up to the operational pressure of $1724 \times 10^3 \text{ N/m}^2$ (250 psig), leakage tests were performed at pressures of 34.5×10^3 , 172.4×10^3 , 689.6×10^3 , and $1724 \times 10^3 \text{ N/m}^2$ (5, 25, 100, and 250 psig). When water was used as the test fluid, the unit was disconnected while filled with water at the desired pressure. The water left at the interface was collected and measured and the mating faces were purged dry. The mating faces were then observed for a 900 second (15 min.) period to verify the absence of a liquid leak. When GN₂ was used as the test fluid, helium was used as the test fluid for both the internal and external leak tests. These tests were performed with the unit in a connected mode with the internal poppets open and separated with the poppet closed. The external surfaces of the unit were then purged dry and observed for a period of 900 seconds (15 min.) to verify the absence of leakage. When helium was used as the test medium, the connector was encased in a polyethylene bag and internally pressurized to the desired pressure with helium (Figure V-11). The leakage rate was determined by inserting the probe from a helium mass spectrometer into a bag and allowing the mass spectrometer output to stabilize.

The operational life cycle tests were performed using Freon-21 (see Figure V-12), water and GN₂ (as shown in Figure V-13) as the test fluids. A cycle consisted of circulating the test fluid through the connector assembly at a pressure up to $1.72 \times 10^6 \text{ N/m}^2$ (250 psig) and a temperature of 274.8 or 355.4°K (35 or 180°F). The isolation valves were then closed and the connector was disconnected. The connector was then reconnected and the isolation valves were opened. This cycle was repeated for a total of 250 cycles using water as a test fluid and 250 cycles using GN₂ as the test fluid. An additional 12 cycles were performed using Freon-21 as the test fluid in order to assure that the operation of the disconnect would not be degraded when exposed to Freon-21 as an operational fluid.

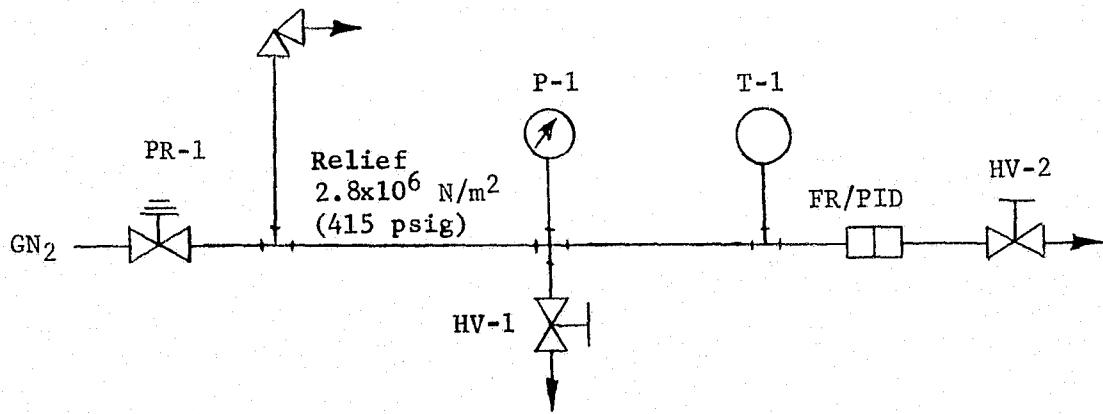

Figure V-9 Proof Test Internally Open

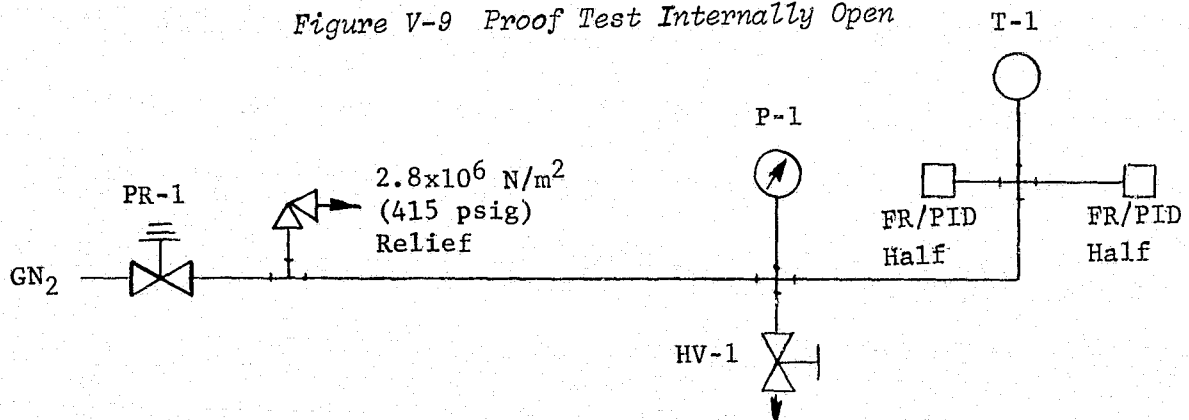

Figure V-10 Proof Test Internally Closed

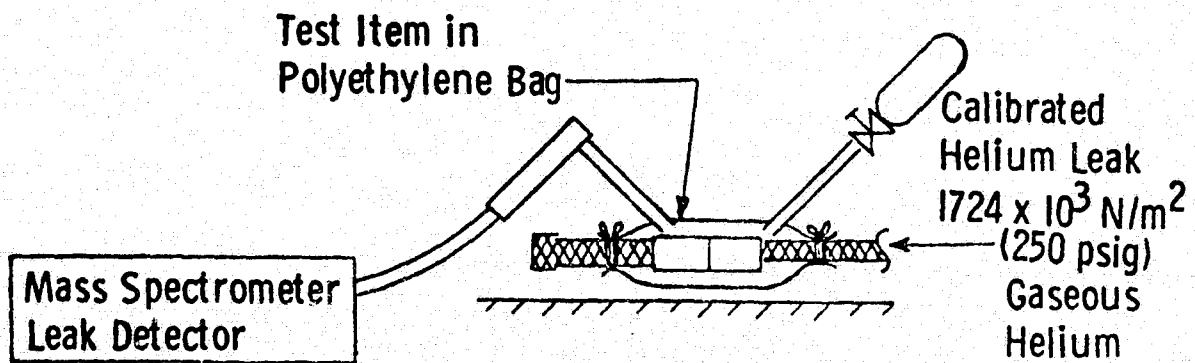

Figure V-11 Gaseous Helium Leak Check

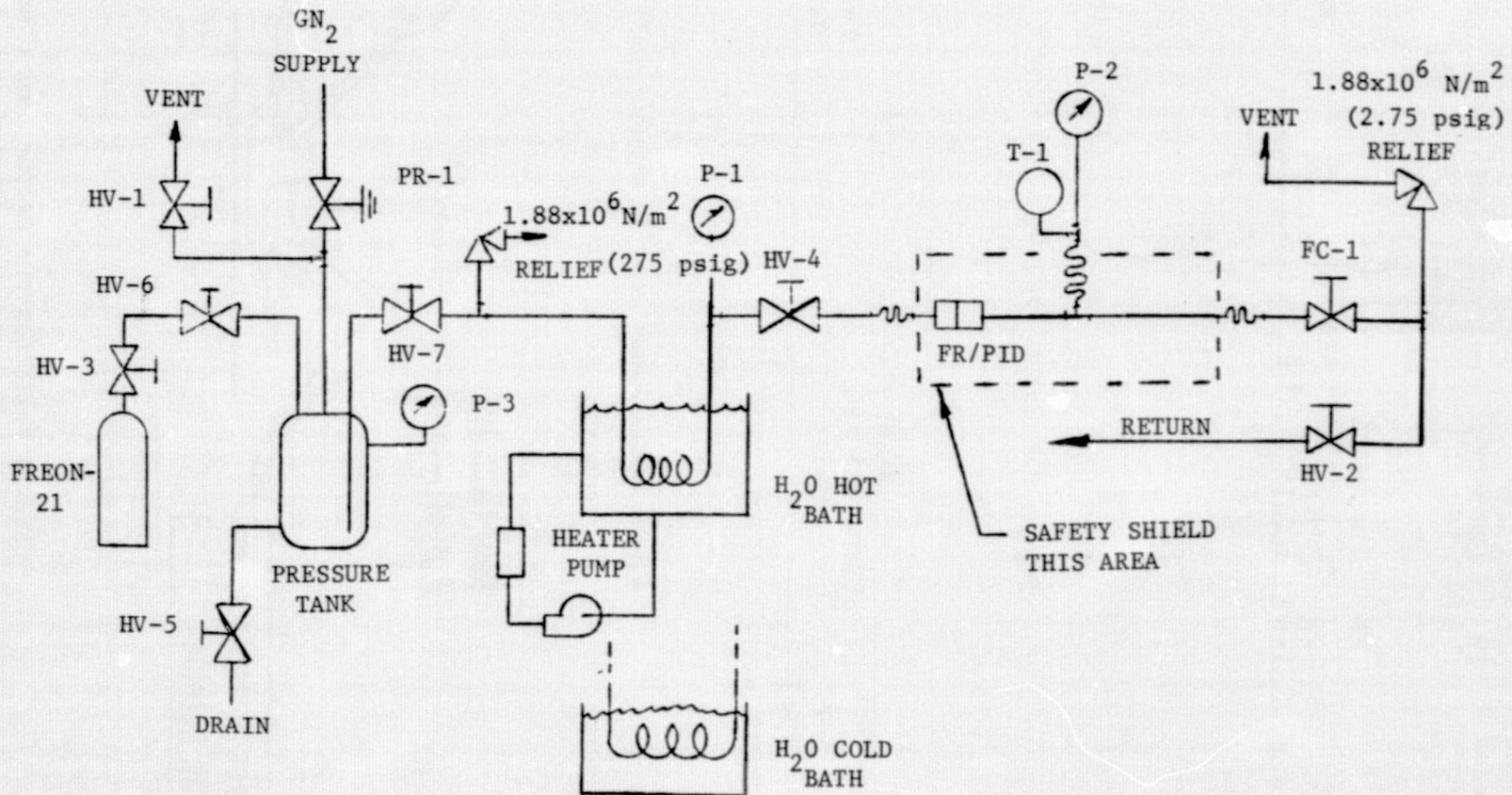

Figure V-12 Freon-21 Exposure and Cycle

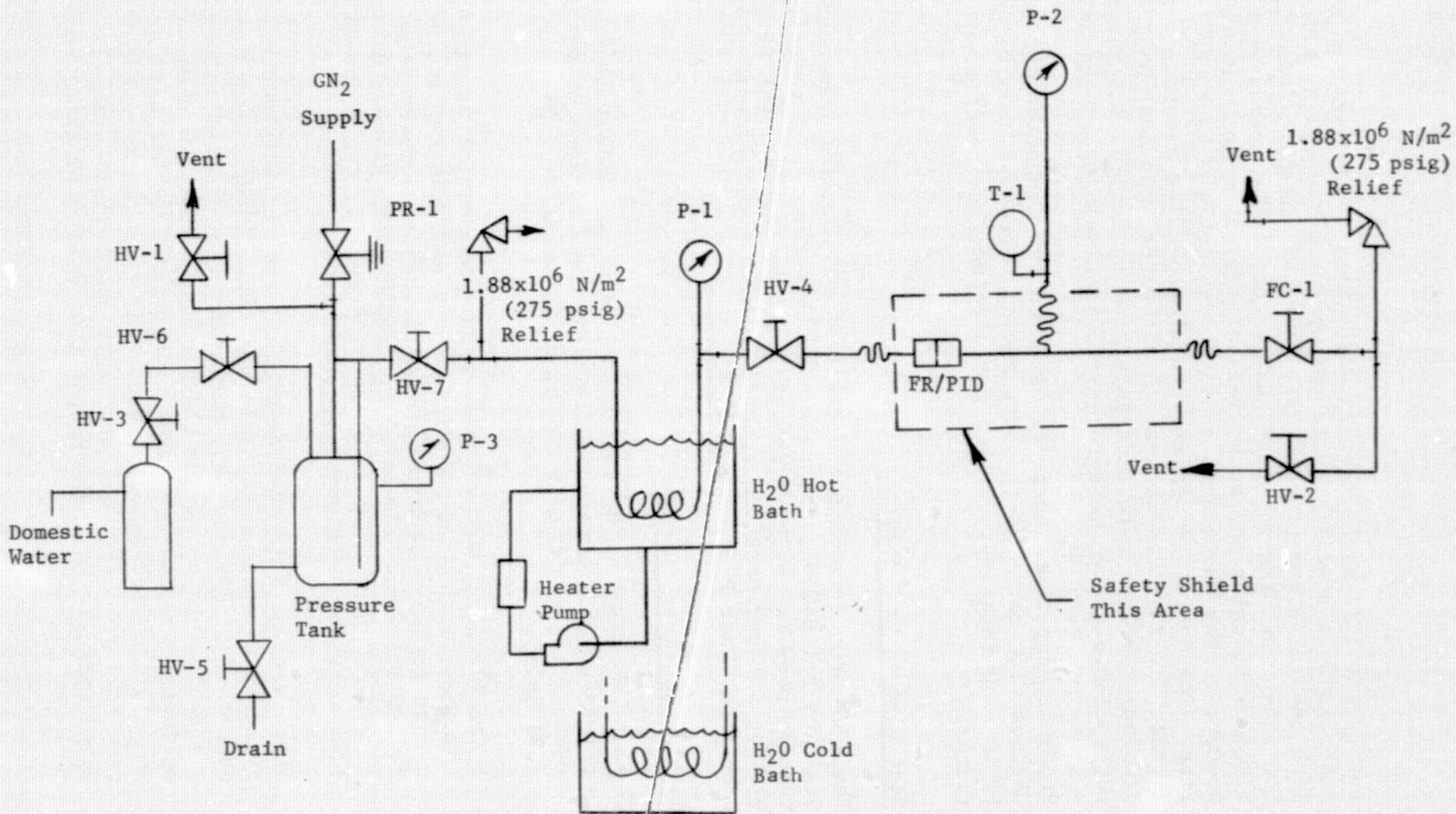

Figure V-13 GN_2 and H_2O Operational Life Cycle

During the life cycle testing when water was being used as the test fluid, a specific cycle was performed to evaluate the hydraulic lock and valve torque characteristics of the unit (see Figure V-14). For this test, the connector and associated plumbing were verified filled with water and both sides of the disconnect were closed in sequence. The absence of a hydraulic lock was verified by observation. The isolation valves were closed using a torque wrench to verify that the required torque did not exceed the design limits. The disconnect halves were then separated to verify that the poppets were fully closed and to measure any fluid remaining at the interface.

Pressure drop tests were performed on the connector using water at various flow rates as the test fluid. Pressure drop for each of the fluid flow rates established a projected flow coefficient (C_V) factor.

Test History and Results

The sequence of testing and the test results are presented in the test log no. H40691, Appendix A of this report. A description of the test methods is included in the Test Description section above. All testing was performed in accordance with the Engineering Propulsion Laboratory Test Procedure, H40691.

Development Test Summary

- *Proof Pressure* - The test unit showed no visible indication of permanent deformation or distortion and no loss of operating capability as a result of being subjected to $2.59 \times 10^6 \text{ N/m}^2$ (375 psig).
- *Hydraulic Lock Test* - The test unit successfully completed this test with no indication of hydraulic lockup and no increase in valve stem torque utilizing pressurized water at $1.72 \times 10^6 \text{ N/m}^2$ (250 psig) for 250 cycles, gaseous nitrogen at $1.72 \times 10^6 \text{ N/m}^2$ (250 psig) for 250 cycles, and Freon-21 at $1.72 \times 10^6 \text{ N/m}^2$ (250 psig) for 12 cycles.

There were no malfunctions or failures recorded during the life cycle tests up through cycle no. 485. After closure of the poppets on cycle no. 485, the technician started to separate the two halves by moving the line half downward when he inadvertently touched an unprotected portion of his hand against the 355.4°K (180°F) valve body. At this point he dropped the line half onto the workbench (see Figure V-15 which is a simulated cycle). He then brought that half back up to reconnect

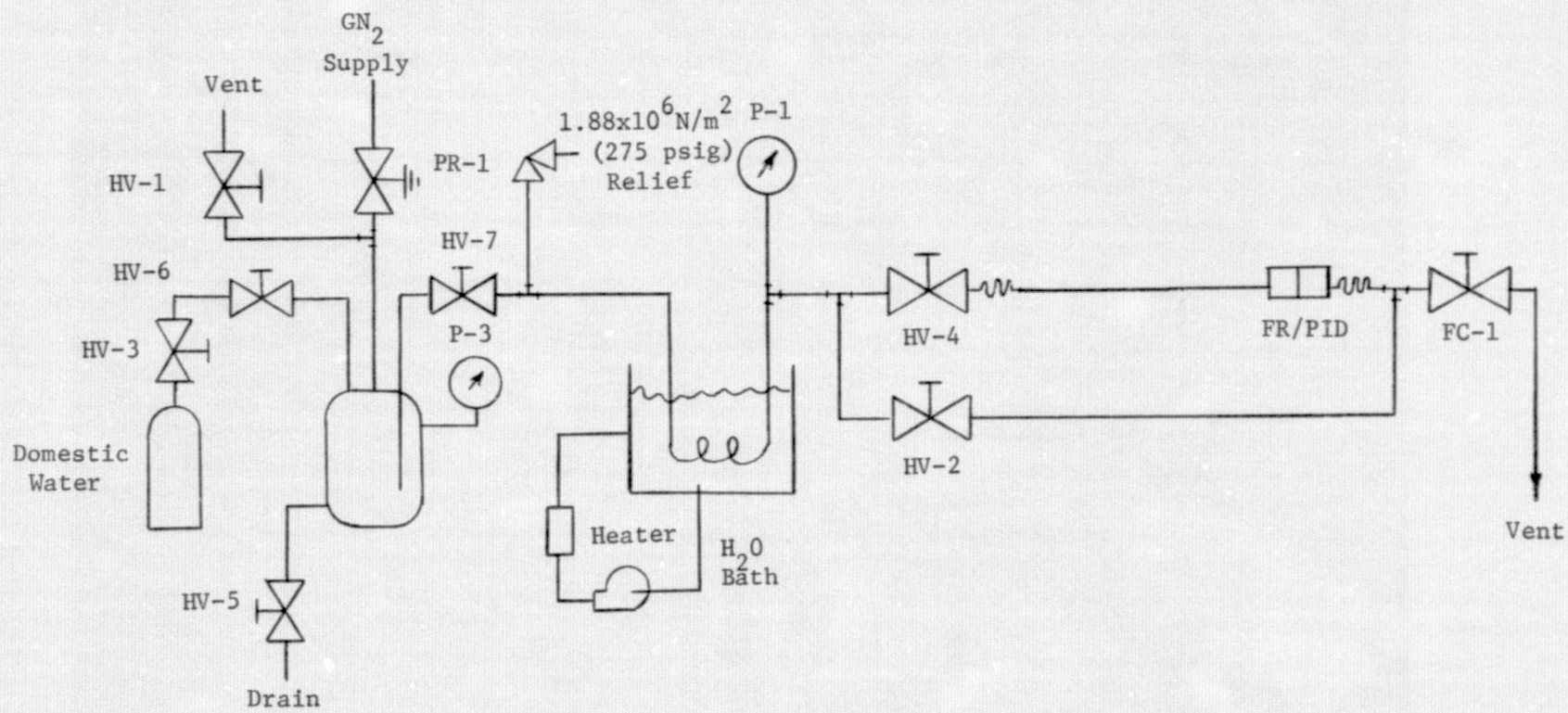

Figure V-14 Hydraulic Lockup Test Configuration

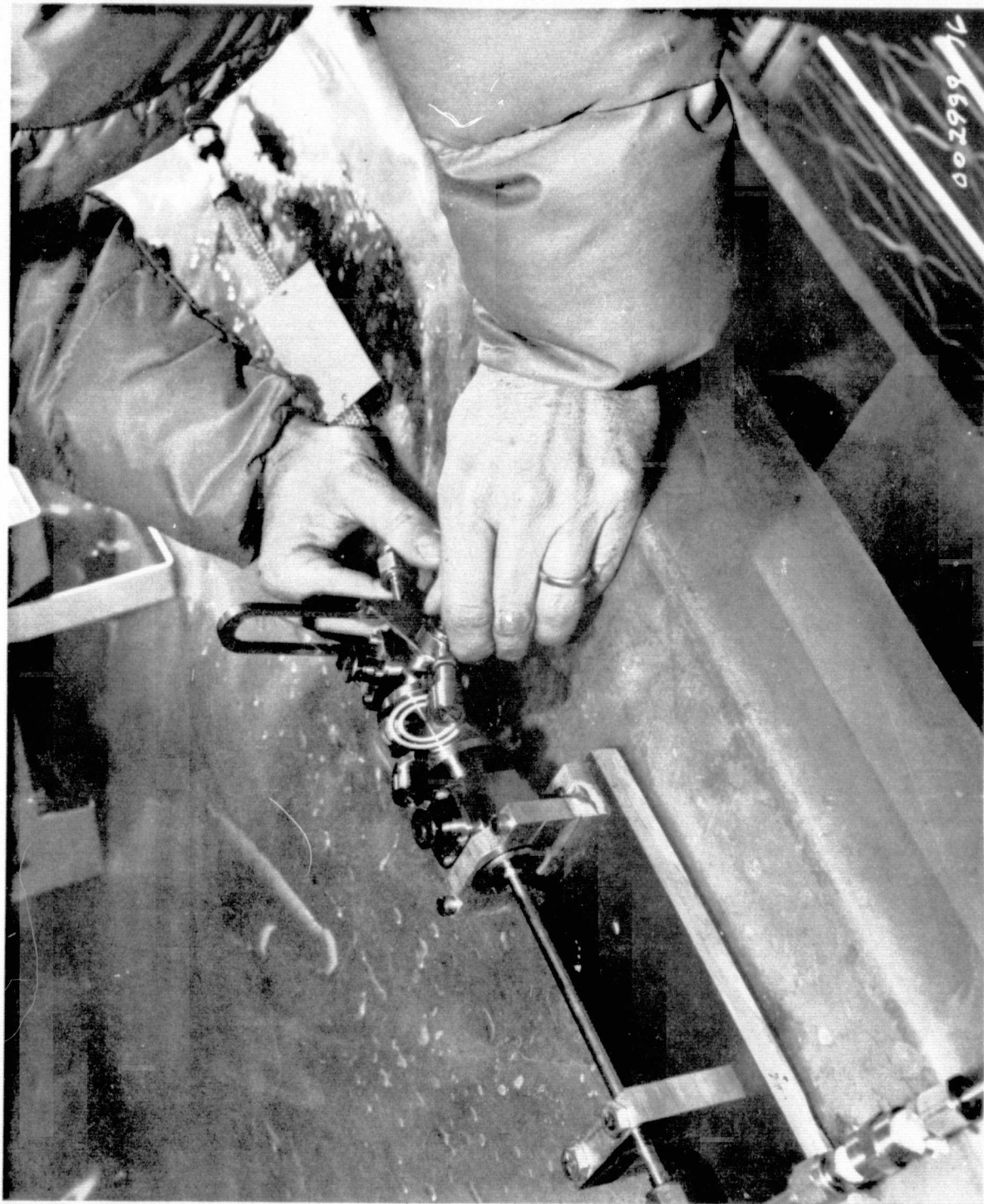

Figure V-15 Simulated Life Cycle Failure at Cycle 485

and latch to the other half without observing the condition of the face seals. On closure of the clamp arm, he could feel that something was wrong. On inspection, both the inner and outer face seals were out of the glands approximately 20 percent at the same location on the bottom and had been damaged. The technician felt he had scraped the component bottom face flange cut-out across the line face and seals when he had reconnected the two halves. The damaged seals showed definite evidence that the inner spring material was deformed in a downward and outward manner indicating something had scraped across the seals. Previous face flange seal blowouts on the NAS9-14376 PID did not show this characteristic and the seal would come completely out of its gland.

At this point, the spare set of interface seals were installed and testing was resumed. At the completion of 500 life cycles, a helium leak check was conducted. The external leak check was off the mass spectrometer scale. On inspection of the new seals with a 10-power glass, scratches were observed on both seals. It was determined that the seals were manually installed and the scratches occurred at that time due to the installation technique. The external leak check on the line half was 1.04×10^{-6} scc/sec which indicated a greater leak rate than at cycle 450 which was at 1.2×10^{-8} scc/sec. Inspecting the poppet face, a small scratch was observed, running from the edge of the poppet face downward on the flange face approximately 0.20 cm (0.078 inch) long toward the area where the seals were damaged. The part was pressurized with water at 1.72×10^6 N/m² (250 psig) and a small bubble formed and stayed. This indicated the pressure trapped between the teflon primary seal and the metal-to-metal backup seal had leaked through the metal-to-metal seal. Since the small scratch was not visible at cycle 450, it is assumed the scratch had occurred at cycle 485 at the same time the seals were damaged.

Inspecting the component half bottom portion flange cutout (cut-out is to intercept the extended clamp leg to assist in face alignment), two sharp edges were noticeable. These edges should be rounded and possibly slightly tapered back to prevent seal damage on the flight article.

- *Leakage Tests* - The test unit was subjected to leakage tests at five different pressures between 3.4×10^4 N/m² (5 psig) and 1.72×10^6 N/m² (250 psig), utilizing water, gaseous helium, and Freon-21. Table V-1 is the results of the leakage tests.

Table V-1 FR/PID Leakage Test Results

Measurement	Life Cycle No.	Test Media	Pressure N/m ² (psig)	Temperature °K (°F)	Result
External	1	Water	3.45x10 ⁴ (5)	274.8 (35)	No leakage evidence
Internal	1	Water	3.45x10 ⁴ (5)	274.8 (35)	No leakage evidence
External	100	Water	1.72x10 ⁵ (25)	274.8 (35)	No leakage evidence
Internal	100	Water	1.72x10 ⁵ (25)	274.8 (35)	No leakage evidence
External	101	Water	6.9x10 ⁵ (100)	274.8 (35)	No leakage evidence
Internal	101	Water	6.9x10 ⁵ (100)	274.8 (35)	No leakage evidence
External	200	Water	1.72x10 ⁶ (250)	274.8 (35)	No leakage evidence
Internal	200	Water	1.72x10 ⁶ (250)	274.8 (35)	No leakage evidence
External	250	Water	1.72x10 ⁶ (250)	355.4 (180)	No leakage evidence
Internal	250	Water	1.72x10 ⁶ (250)	355.4 (180)	No leakage evidence
External	251	He	3.45x10 ⁴ (5)	274.8 (35)	No leakage >1.3x10 ⁻¹⁰ scc/sec
Internal	251	He	3.45x10 ⁴ (5)	274.8 (35)	No leakage >1.3x10 ⁻¹⁰ scc/sec
External	350	He	3.45x10 ⁴ (5)	274.8 (35)	No leakage >1.3x10 ⁻¹⁰ scc/sec
Internal	350	He	3.45x10 ⁴ (5)	274.8 (35)	No leakage >1.3x10 ⁻¹⁰ scc/sec
External	351	He	6.9x10 ⁵ (25)	274.8 (35)	No leakage >1.3x10 ⁻¹⁰ scc/sec
Internal	351	He	6.9x10 ⁵ (25)	274.8 (35)	No leakage >1.3x10 ⁻¹⁰ scc/sec
External	352	He	6.9x10 ⁵ (100)	274.8 (35)	No leakage >1.3x10 ⁻¹⁰ scc/sec
Internal	352	He	6.9x10 ⁵ (100)	274.8 (35)	No leakage >1.3x10 ⁻¹⁰ scc/sec
External	450	He	1.72x10 ⁶ (250)	274.8 (35)	1.3 x 10 ⁻⁸ scc/sec
Internal (Line Half)	450	He	1.72x10 ⁶ (250)	274.8 (35)	9.6 x 10 ⁻⁹ scc/sec
Internal (Component Half)	450	He	1.72x10 ⁶ (250)	274.8 (35)	1.2 x 10 ⁻⁸ scc/sec
External	500	He	1.72x10 ⁶ (250)	355.4 (180)	Leakage off scale--see life cycle notes at Cycle 485
Internal (Line Half)	500	He	1.72x10 ⁶ (250)	355.4 (180)	7.3 x 10 ⁻⁸ scc/sec
External (Component Half)	500	He	1.72x10 ⁶ (250)	355.4 (180)	1.04x10 ⁻⁶ scc/sec
External	512	F-21	1.72x10 ⁶ (250)	Ambient	No leakage evidence
Internal	512	F-21	1.72x10 ⁶ (250)	Ambient	No leakage evidence

4T-14

- *Pressure Drop Tests* - The pressure drop test results are shown in Figure V-16. The pressure drop for a water flowrate of 0.063 kg/sec (500 lbs/hr) is 3.54×10^4 N/m² (5.7 psid). The flow coefficient for the FR/PID was projected at 0.41.

Resolution of Contract NAS9-14376 PID Problems Summary

During the test program, the Contract NAS9-14376 development PID problem areas (see Table III-1) did not occur. It can be concluded that the design concepts incorporated into the FR/PID to resolve these problems are positive and should be included in the flight article.

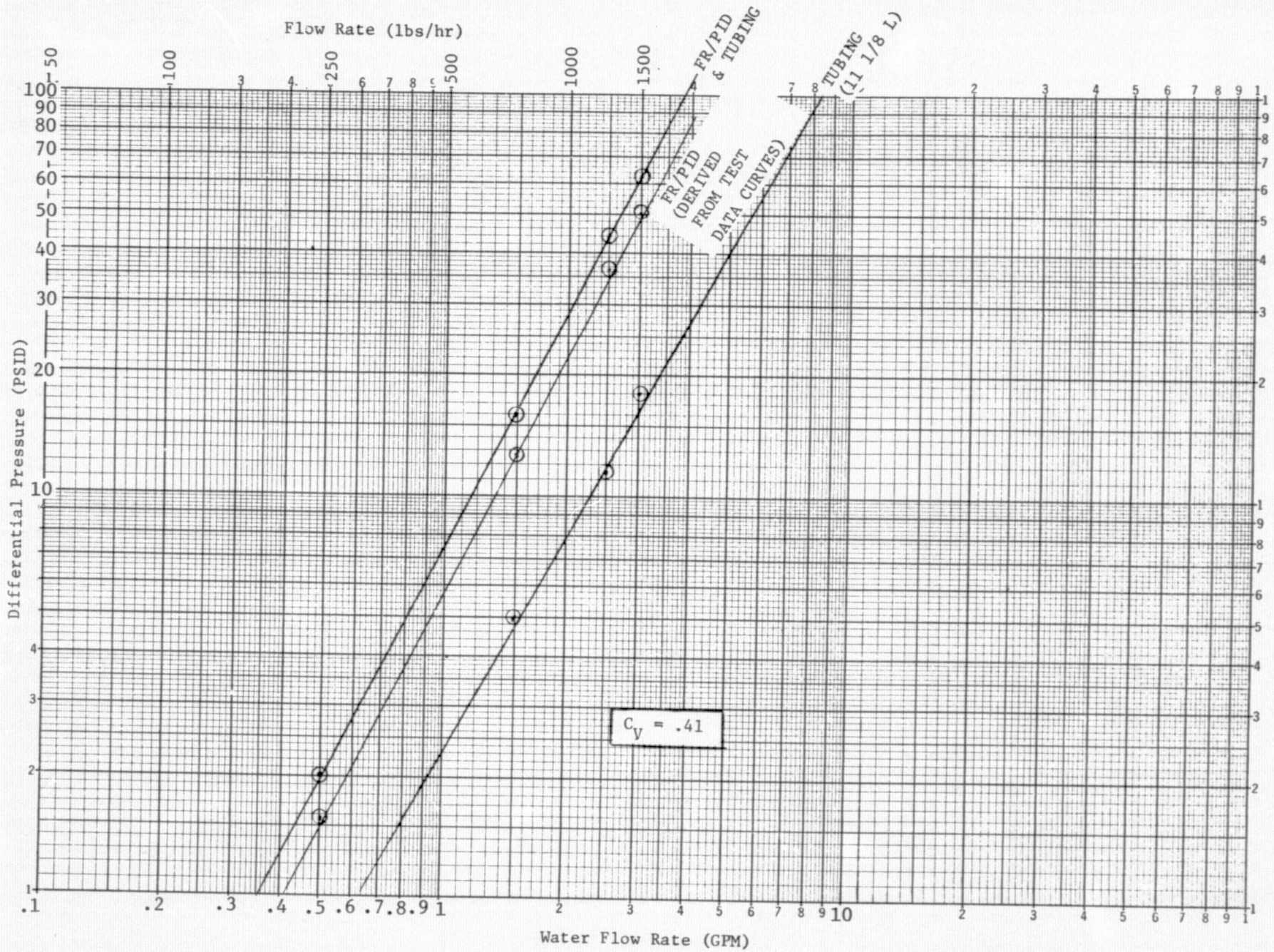

Figure V-16 FR/PID Pressure Drop Test Results

VI. FINAL DESIGN

The purpose of this task was to establish the final design baseline for the FR/PID. This involved reviewing the test program to update the design drawings (RES3157000) to reflect modifications to the FR/PID during the test, developing further recommended design changes based upon the test results, and determining potential usages in the Shuttle EC/LSS system and GSE potential requirements.

A. FINAL DEVELOPMENT DESIGN BASELINE

The development test log and report was reviewed and changes were added to the RES3157000 design drawings to reflect the "as-built" condition and modifications incorporated as a result of the testing. The following is a summary of the modifications to the FR/PID as a result of the development testing:

Pressure Drop Reduction

To lower the pressure drop, an attempt was made to minimize the expansion/contraction effects of the flowing fluid. This was accomplished by increasing the stroke of the poppet spool from .99 mm (.039 in.) to 1.95 mm (.077 in.) and opening the flow ports at the forward end of the poppet spool. The flow holes in -001 poppet spool were opened up from 1.78 mm (.070 in.) to 2.06 mm (.081 in.) in diameter. The -003 and -007 spacers were reduced in thickness from 1.27 mm (.050 in.) to .48 mm (.019 in.) to compensate for additional poppet displacement. Likewise, the -014 cam stem was modified to increase the high point on the cam by .97 mm (.038 in.). The slot length on -013 yoke was increased to accommodate the new cam stem. With the pressure drop reduction modifications incorporated the pressure drop for a water flowrate of 0.063 kg/sec (500 lbs/hr) is $2.05 \times 10^4 \text{ N/m}^2$ (3.3 psid) and the flow coefficient (C_V) for the FR/PID is projected at 0.55. The modification increased flow by 34 percent. The pressure drop test results are shown in Figures VI-1 and VI-2.

Weight Reduction

To reduce weight, lightening holes and metal trimming was performed on several details. These included the -001 poppet spool, -014 cam stem, -018 valve body, -021 valve body, and the -026 (-027) handle support legs.

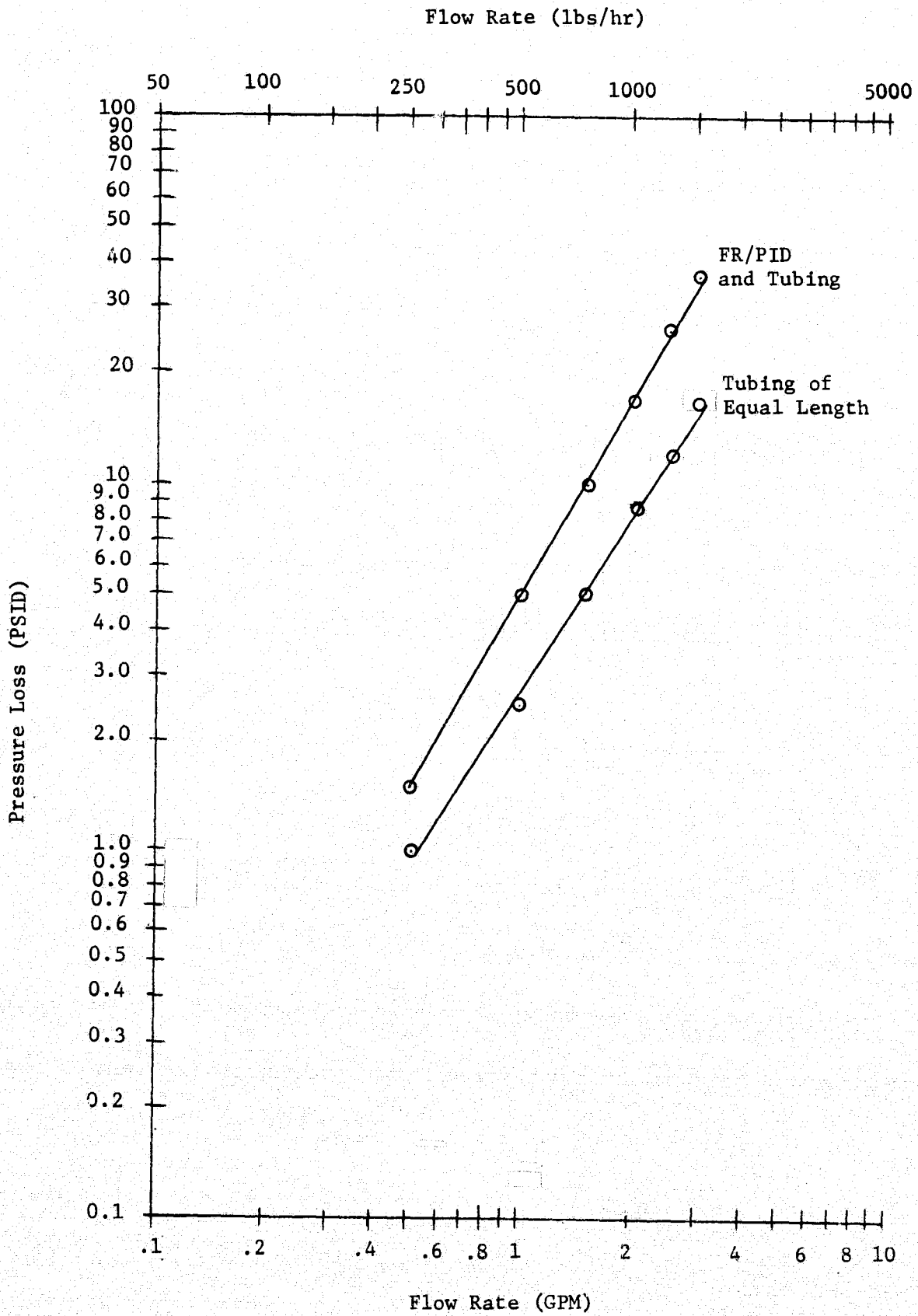

Figure VI-1 FR/PID Flow vs ΔP

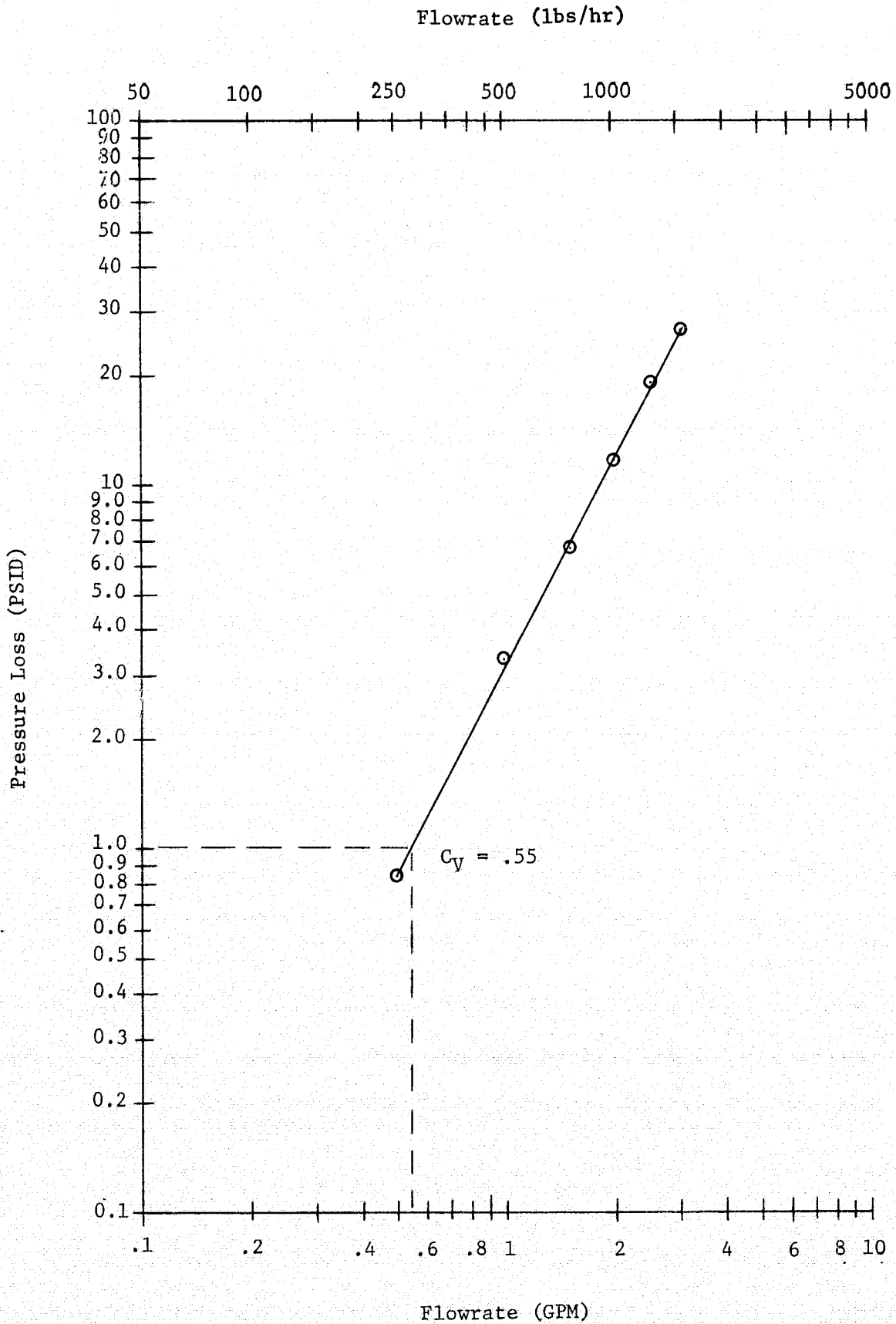

Figure VI-2 FR/PID Flow vs ΔP (Calculated From Test Results)

Design Improvements

To prevent scratching the separation plane on the line side half of the FR/PID and the possibility of accidentally pulling out the face seals, during separation and mating, the forward edge and corners of the indexing flange on the component side half have been rounded off. If any rubbing takes place, it will be from a blunt smooth surface and not sharp edges or corners.

B. POTENTIAL SHUTTLE APPLICATIONS

The Space Shuttle Orbiter Environmental Control and Life Support System has several areas of possible PID maintenance applications. These systems include the following:

- Cabin air
- Freon loop
- Oxygen
- Potable H₂O
- Nitrogen
- Coolant H₂O
- LCG H₂O
- Ammonia
- Waste Water
- O₂/N₂ Vent

Within each system, the following specific usages are identified:

- Disconnects at system interfaces
- Pressure, temperature, humidity, flow transducers
- Maintainable filters
- Pumps
- Low reliability fluid components

An additional usage of the PID could be for the GSE interface with the Shuttle Orbiter. This would allow such services as filling systems with fluids and gases, flushing systems for cleaning purposes, and draining systems during ground refurbishment.

VII. QUALITY ASSURANCE, RELIABILITY AND SAFETY SUMMARY

A. QUALITY ASSURANCE

Quality assurance effort was involved in the design, procurement, receiving, fabrication, testing, shipping and final inspection of the deliverable end item. In the design phase, system analysis was performed and the following items were identified and incorporated into the design to assure the quality of the hardware:

- Notes were added to the RES3157000 design drawings that specified tool requirements for operations and maintenance, assembly setup instructions for the disconnect and coupler, and general notes pertaining to lubrication requirements for slipping surfaces and lubrication of threads to prevent galling.
- Dimensional buildup tolerances were analyzed to determine fit interferences and design tolerances on detailed parts. These tolerance dimensions were incorporated in the design drawings.
- Wear and contamination areas of metal-to-metal contact were identified. Appropriate notes were added to the design drawings.
- Finish callouts were added to the design drawings for passivating the stainless steel parts for added resistance to corrosion. Surface finish was specified for seal glands and seat surfaces.
- All load carrying parts were stress analyzed to preclude material failure. All sharp corners were eliminated.
- A design analysis was prepared to assure that the operational functions could be successfully achieved.

During the development task, quality assurance was active in the procurement cycle by being responsible for specification of the inspection processes and supplier qualification. All of the raw materials, parts, and components were inspected in receiving.

During the fabrication and build of the end item, in-process and final inspections were made to assure the proper level of workmanship and quality of the end item. To insure proper mating of parts, critically dimensioned detail parts were machined and fitted to individual disconnect halves. This resulted in proper flatness, slip, flushness and fit of parts.

The test setup was inspected for structural integrity and setup per the test procedures. During all testing, the test conductor was monitored at the start of each test sequence and periodically throughout the test for conformance with the test procedure. All instrumentation was inspected for calibration time certification requirements. The test engineer recorded data from the test conductor with the design engineer in observance.

Finally, quality assurance was also responsible for monitoring the packaging and shipment of the end items. This included both documentation and hardware.

B. RELIABILITY

A Failure Mode and Effect Analysis (FMEA) was performed during the design. Information derived included: failure mode, result on system, design feature to preclude failure, crew action required and single point failures. From this information, areas of critical weaknesses were searched out and corrective measures were incorporated in the final design. These included the following:

- The elimination of spring-loaded actuation or closure features for poppet closure.
- Incorporation of a positive means to identify poppet closure prior to separation of disconnect halves.
- Incorporation of redundant sealing techniques in all dynamic areas.
- The elimination of threaded connections to prevent contamination during disconnect.
- Recessed groove on flange face to match face seal on mating face to prevent seal damage.
- Tapered mating flanges and clamping mechanism keyed leg for alignment of two disconnect halves.
- All functions for FR/PID operation are located on a single side such that all required actions can be performed by access at a single plane perpendicular to the centerline of the fluid parts.

C. SAFETY

Safety concerns were considered and appropriate corrective measures were provided in each task of the program. During the conceptual and final designs, a stress analysis was performed on all detail parts and assemblies of the FR/PID. The detail parts were designed in accordance with the stress analysis and materials were selected to meet the stress and environmental requirements.

The design of the FR/PID incorporates the following additional safety features:

- The integral clamping mechanism cannot be opened unless the internal poppets are closed to prevent spraying the operator with high pressure liquid or gas upon disconnection.
- If contamination is trapped between the poppet and its seat, the stem shaft (for poppet closure) cannot be rotated 3.14 radians (180°) against its pin stop for visual indication that the poppet is not closed.
- Redundant sealing is provided at dynamic seal locations to prevent high pressure liquid or gas spray on operator in both the connected or disconnected modes.
- The design allows for a volume expansion of trapped Freon-21 between the disconnect's halves when connected and with the poppets of each half closed. This prevents overstressing the structural integrity of the PID's materials.

During the fabrication of the flight representative PID assemblies, Martin Marietta machine shop safety standards were followed at all times. A test procedure was prepared for the test program and it was reviewed and signed by the safety engineer assigned to the program. The test support hardware design drawings were reviewed and approved by the safety representative. After the test hardware and FR/PID assembly was installed, the safety representative reviewed the setup and required the following two additional safety precautions:

- 1) The test setup must include a transparent shield that protects the test personnel from an inadvertent release of high pressure test fluid upon FR/PID separation.

- 2) The test disconnects must be "safety wired" to the test fixture to retain them in the event the fluid connections separate under pressure.

After installation of these additional safety features to the test setup, the FR/PID assembly was proof measured to $2.59 \times 10^6 \text{ N/m}^2$ (375 psig) (1.5 times the maximum operational pressure). Throughout the test program, Martin Marietta safety standards were followed.

APPENDIX A

TEST LOG NO. H40691
 FLIGHT REPRESENTATIVE
 POSITIVE ISOLATION DISCONNECT

<u>DATE</u>	<u>TIME</u>	<u>COMMENTS</u>
11/23/76	1000	The test setup has been completed and reviewed by engineering, project and safety.
	1015	Starting to run functional checkout test.
	1030	The functional test was completed but there was a small leak at the bottom of the inlet housing to the disconnect. Project engineer has not shown up yet today, so we will go into a hold until the project engineer can be contacted. We will not attempt to do anything to the disconnect until the project engineer reviews the problem.
	1500	The leak problem has been reviewed by the project engineer (Tom Jonkoniec). The leak is coming from the inlet end cap. The cap was removed, inspected and tightened. The FR/PID was reinstalled and checked at $6.9 \times 10^5 \text{ N/m}^2$ (100 psi) with H_2O and it looked good. The test will continue tomorrow.
11/24/76	0830	Setup is ready for proof test.
	0900	The proof test is complete and there was no evidence of damage to the disconnect from either the internally open or closed condition.
	0930	The hydraulic lockup test has been completed and there was no indication of a torque change to either open or close the disconnect. The system is now being setup to start the H_2O cycle tests at 274.8°K (35°F).
	1230	The water cycle setup has been completed and the heat exchanger bath is at 273.7°K (33°F). Flow at $3.45 \times 10^4 \text{ N/m}^2$ (5 psi) is on in order to stabilize the FR/PID at $273.15 - 274.8^\circ\text{K}$ ($32^\circ - 35^\circ\text{F}$).
	1500	The first cold exposure at $3.45 \times 10^4 \text{ N/m}^2$ (5 psig) was completed with valves both open and closed on disconnect. There were no problems and so on 11/29/76, we will start the first 100 disconnect cycles. It shall be noted that the hold times called out in para. 5.4.8 and 5.4.12 of the test procedure were reduced to 900 sec (15 min.) with the project engineer's approval.

<u>DATE</u>	<u>TIME</u>	<u>COMMENTS</u>
11/29/76	0930	The setup has been made ready to start the first 100 cycles at $3.45 \times 10^4 \text{ N/m}^2$ (5 psig) with H_2O at 274.8°K (35°F).
	1400	The disconnect cycles with 274.8°K (35°F) H_2O have been completed up through $1.72 \times 10^6 \text{ N/m}^2$ (250 psig) with no problem. There is not enough time left today to warm up the water to 352.6°K (175°F) so we will hold until tomorrow. The photographer is here now to take some pictures.
	1430	The pictures have been taken and the setup will be secured with some power on the heater and a small GN_2 purge on the system.
11/30/76	0800	The setup is ready to go on 5.4.26 in the procedure but we are having trouble getting the water heated up to 355.4°K (180°F). The tank is not properly insulated, the heater may be a little small and the ambient temperature is too cold. Insulation problems on the tank are being worked.
	0915	The FR/PID is up to 351.5°K (173°F) and we will run at this temperature.
	1030	The H_2O tests have been completed with no problems and we will now set up for the internal and external gas leakage tests. There is a small problem because it is too cold outside to use an He leak detector.
	1100	Because of problems in working with the leak detector outside, the temperature requirements on the gas cycle tests have been waived for the time being, by the project engineer. The setup is being taken to the valve shop where the cycles and leak tests will be run at ambient temperature. The internal leak test has been changed also. The water displacement approach has been deleted for now and we will bag each half and use a leak detector to at least get an indication of a leak. Depending on how strong the indication is, we will then decide if it is necessary to obtain a quantity value of leak rate.
	1300	The setup for external leakage at $3.45 \times 10^4 \text{ N/m}^2$ (5 psig) is ready. The CEC is calibrated at 1.3×10^{-10} sensitivity. Probe is open with scale reading of 12 on 1 scale, for a background. During the 300 sec (5 min.) hold the background continued to drop indicating no leakage. Internal leakage at $3.45 \times 10^4 \text{ N/m}^2$ (5 psig) on handle half--background is 4 on 1 scale. No indication of leak after 300 sec (5 min.).
		$1.72 \times 10^5 \text{ N/m}^2$ (25 psi) leak test
		External leak:
		Background = 38 x 1 0 leak after 300 sec (5 min.) hold

<u>DATE</u>	<u>TIME</u>	<u>COMMENTS</u>
		Internal leak; handle half Background: 20 x 1 0 leak after 300 sec (5 min.) hold
		Internal leak; other half Background: 30 x 1 0 leak after 30 sec (5 min.) hold
		$6.9 \times 10^5 \text{ N/m}^2$ (100 psi) leak test External leak: Background = 20 x 1 0 leak after 300 sec (5 min.) hold
		Internal leak; other half Background = 30 x 1 0 leak after 300 sec (5 min.) hold
		Internal leak; handle half Background = 26 x 1 Meter reading = 69 x 1 in 300 sec (5 min.) Leak Rate = (69-26) $1.3 \times 10^{-10} = 5.6 \times 10^{-9}$ scc/sec
	1515	Secured setup for the 'ay.
12/01/76	0800	Setup ready to go for 100 ambient cycles at (250 psia)
	0930	$1.72 \times 10^6 \text{ N/m}^2$ (250 psi) leakage test: sensitivity 2.1×10^{-10} on 12/01/76) External leak: Background = 48 x 1 Meter reading = 22 x 5 after 300 sec (5 min.) Leak Rate = (110-48) $2.1 \times 10^{-10} = 1.3 \times 10^{-8}$ scc/sec
		Internal leakage at $1.72 \times 10^6 \text{ N/m}^2$ (250 psi) Handle half: Background = 40 x 1 Meter reading = 86 x 1 after 300 sec (5 min.) Leak Rate = (86-40) $2.1 \times 10^{-10} = 9.6 \times 10^{-9}$ scc/sec
		Other half: Background = 50 x 1 Meter reading = 22 x 5 after 300 sec (5 min.) Leak rate = (110-50) $2.1 \times 10^{-10} = 1.2 \times 10^{-8}$ scc/sec

DATETIME

1030 Starting setup for 1.72×10^6 N/m² (250 psia) and 355.4°K (180°F) cycles.

1230 At cycle #35 the seals came out of the grooves and were mashed between the flanges of the disconnect. The seals were disengaged from the grooves because the two halves of the disconnect slipped when they were being separated and because of the small separation plane, it was not noticed that the seals had come out of the grooves.

1320 A new set of seals have been installed and the setup is being heated back up. We will pick up the count at cycle #35.

1515 Hot cycles at 1.72×10^6 N/m² (250 psi) have been completed. Leak check at 1.72×10^6 N/m² (250 psi) and 355.4°K (180°F):
External Leakage: leak detector offscale.

Internal Leak Check:

Handle End:

Background = 50 x 1

Meter reading = 80 x 5

Leak Rate = $400-50 (2.1 \times 10^{-10}) = 7.3 \times 10^{-8}$

Other End:

Background = 40 x 1

Meter reading = 50 x 100

Leak Rate = $(5000-40) 2.1 \times 10^{-10} = 1.04 \times 10^{-6}$

The new seals are probably the reason for the high external leak rate but they should not have affected the internal leakage. We will try an ambient temperature leak check in the morning.

12/02/76 0800 The ambient temperature leak check was so bad that it could not be measured on a leak detector. We tried some leak check fluid and there were bubbles all around.

The surfaces and seals have been inspected with a 10 power glass and there are some scratches on both parts. The proper procedure was not used when the new seals were installed according to John Cool.

The disconnect mechanism was tightened 1/4 turn and that reduced the leak to two areas 3.14 radians (180°) apart. The mechanism was tightened 1/8 more turn and that made the leak worse and so we backed off to the 1/4 turn.

DATE

TIME

COMMENTS

1000 A water leakage check has been made and there is a drop every 8 sec on external check at 1.72×10^6 N/m² (250 psig). On the internal check a small bubble forms at one point and stays there, because there is a new scratch at the lip. This is on the handle half; the other half looks good.

1030 The seal vendor has been contacted and he is looking for some more seals. The project engineer has decided to wait until we get a call from the seal vendor.

1100 The project engineer changed his mind and wants to run the freon and pressure drop tests while we are waiting for the new seals to arrive. The seal vendor called back and he has some glass-impregnated teflon seals which he will mail to us today.

1300 The 12 freon cycles at 1.72×10^6 N/m² (250 psia) and ambient temperature have been completed. The freon was run at 283.7°K (51°F). The external leakage check showed no indication of any leakage. The internal leakage checks showed a wetting of the surface at two spots and an occasional release of a droplet. The other half showed no indication of leakage.

The setup is being made for the pressure drop test.

12/03/76 1000 The pressure drop on the tare tube was run and the results were as follows:

10^{-5} m ³ /sec (GPM)	10^3 N/m ² (PSID)	10^{-5} m ³ /sec (GPM)	10^3 N/m ² (PSID)
3.16 (.5)	4.83 (.7)	12.62 (2.0)	57.92 (8.4)
6.31 (1.0)	15.86 (2.3)	15.78 (2.5)	82.74 (12.0)
9.47 (1.5)	34.49 (5.0)	18.93 (3.0)	115.84 (16.8)

The water temperature was ... 280.4°K (45°F).

The pressure drop test using the FR/PID was attempted but the ΔP transducer went offscale between 9.72×10^{-5} m³/sec (1.54 - 2.0 GPM).

10^{-5} m ³ /sec (GPM)	10^3 N/m ² (PSID)
3.16 (.5)	15.17 (2.2)
6.31 (1.0)	55.16 (8.0)
9.47 (1.5)	117.22 (17.0)
12.62 (2.0)	> 172.38 (25.0)

DATE

TIME

COMMENTS

A higher range will be set up and the test will be rerun.

1500 The pressure drop tests were all rerun with a higher range ΔP transducer.

The results are as follows:

Cycles $10^{-5} \text{m}^3/\text{sec}$ (GPM)	TARE Cycles 6.35 mm (.25 in.) Tube .89 mm (.035 in.) Wall (Water Temp = 280.37°K (45°F))					PID Cycles (Water Temp = 280.93°K (46°F))				
	ΔP (10^3 N/m^2 (psi))					ΔP (10^3 N/m^2 (psi))				
	1	2	3	4	5	1	2	3	4	5
3.16 (.5)	4.83 (.7)	4.83 (.7)	5.52 (.8)	4.83 (.7)	4.83 (.7)	15.17 (2.2)	12.62 (2.0)	12.62 (2.0)	12.62 (2.0)	12.62 (2.0)
6.31 (1.0)	15.86 (2.3)	12.62 (2.0)	12.62 (2.0)	12.62 (2.0)	12.62 (2.0)	55.16 (8.0)	55.16 (8.0)	48.27 (7.0)	48.27 (7.0)	48.27 (7.0)
9.47 (1.5)	34.49 (5.0)	34.49 (5.0)	34.49 (5.0)	31.03 (4.5)	27.58 (4.0)	117.22 (17.0)	110.32 (16.0)	110.32 (16.0)	110.32 (16.0)	110.32 (16.0)
12.62 (2.0)	57.92 (8.4)	55.16 (8.0)	55.16 (8.0)	55.16 (8.0)	53.78 (7.8)	186.17 (27.0)	191.68 (27.8)	191.68 (27.8)	193.06 (28.0)	195.13 (28.3)
15.78 (2.5)	82.74 (12.0)	79.29 (11.5)	86.19 (12.5)	82.74 (12.0)	81.36 (11.8)	310.28 (45.0)	303.38 (44.0)	299.93 (43.5)	303.38 (44.0)	296.49 (43.0)
18.93 (3.0)	115.84 (16.8)	124.11 (18.0)	117.22 (17.0)	117.22 (17.0)	117.22 (17.0)	430.94 (62.5)	437.83 (63.5)	426.11 (61.8)	428.87 (62.2)	434.39 (63.0)

01/11/77

Since the completion of the previous series of tests, some re-design on the disconnect has been done in order to lower the pressure drop through the unit. A series of pressure drop tests, the same as were previously run, will now be conducted.

DATE TIME

COMMENTS

Cycles 10 ⁻⁵ m ³ / sec (GPM)	TARE Cycles 6.35 mm (.25 in.) Tube .89 mm (.035 in.) Wall (Water Temp ■ 279.26°K (43°F))					PID Cycles (Water Temp ■ 279.26°K (43°F))				
	ΔP (10 ³ N/m ² (psi))					ΔP (10 ³ N/m ² (psi))				
	1	2	3	4	5	1	2	3	4	5
3.16 (.5)	3.45 (.5)	6.89 (1.0)	6.89 (1.0)	6.89 (1.0)	6.89 (1.0)	5.17 (.75)	10.34 (1.5)	10.34 (1.5)	10.34 (1.5)	10.34 (1.5)
6.31 (1.0)	17.24 (2.5)	17.24 (2.5)	17.24 (2.5)	17.24 (2.5)	17.24 (2.5)	29.3 (4.25)	34.49 (5.0)	34.49 (5.0)	34.49 (5.0)	34.49 (5.0)
9.47 (1.5)	34.49 (5.0)	34.49 (5.0)	34.49 (5.0)	34.49 (5.0)	34.49 (5.0)	68.95 (10.0)	68.95 (10.0)	68.95 (10.0)	68.95 (10.0)	68.95 (10.0)
12.62 (2.0)	55.16 (8.0)	55.16 (8.0)	55.16 (8.0)	55.16 (8.0)	55.16 (8.0)	120.66 (17.5)	120.66 (17.5)	117.22 (17.0)	120.66 (17.5)	117.22 (17.0)
15.78 (2.5)	82.74 (12.0)	82.74 (12.0)	82.74 (12.0)	82.74 (12.0)	82.74 (12.0)	179.27 (26.0)	182.72 (26.5)	182.72 (26.5)	179.27 (26.0)	186.17 (27.0)
18.93 (3.0)	110.32 (16.0)	113.77 (16.5)	113.77 (16.5)	117.22 (17.0)	117.22 (17.0)	255.11 (37.0)	255.11 (37.0)	262.01 (38.0)	262.01 (38.0)	258.56 (37.5)

— H. K. Merrill