

**NASA TECHNICAL  
MEMORANDUM**



**NASA TM X-3473**

**NASA TM X-3473**

**CASE FILE  
COPY**

**MASS STUDY FOR MODULAR APPROACHES  
TO A SOLAR ELECTRIC PROPULSION MODULE**

*G. Richard Sharp, James E. Cake,  
Jon C. Oglebay, and Francis J. Shaker*

*Lewis Research Center  
Cleveland, Ohio 44135*

**NATIONAL AERONAUTICS AND SPACE ADMINISTRATION • WASHINGTON, D. C. • MARCH 1977**

1. Report No. <b>NASA TM X-3473</b>	2. Government Accession No.	3. Recipient's Catalog No.	
4. Title and Subtitle <b>MASS STUDY FOR MODULAR APPROACHES TO A SOLAR ELECTRIC PROPULSION MODULE</b>		5. Report Date <b>March 1977</b>	6. Performing Organization Code
		8. Performing Organization Report No. <b>E-8800</b>	10. Work Unit No. <b>506-22</b>
7. Author(s) <b>G. Richard Sharp, James E. Cake, Jon C. Oglebay, and Francis J. Shaker</b>		11. Contract or Grant No.	
9. Performing Organization Name and Address <b>Lewis Research Center National Aeronautics and Space Administration Cleveland, Ohio 44135</b>		13. Type of Report and Period Covered <b>Technical Memorandum</b>	
		14. Sponsoring Agency Code	
12. Sponsoring Agency Name and Address <b>National Aeronautics and Space Administration Washington, D. C. 20546</b>		15. Supplementary Notes	
16. Abstract <p>A mass study is presented for two modular approaches to the design of a conceptual solar electric propulsion module. The propulsion module comprises six to eight 30-cm thruster and power processing units, a mercury propellant storage and distribution system, a solar array ranging in power from 18 to 25 kW, and the thermal and structure systems required to support the thrust and power subsystems. Launch and on-orbit configurations are presented for both modular approaches. The propulsion module satisfies the thermal design requirements of a multimission set including: Mercury, Saturn, and Jupiter orbiters, a 1-AU solar observatory, and comet and asteroid rendezvous. A detailed mass breakdown and a mass equation relating the total mass to the number of thrusters and solar array power requirement is given for both approaches.</p>			
17. Key Words (Suggested by Author(s)) <b>Solar electric propulsion Propulsion module Interplanetary spacecraft</b>		18. Distribution Statement <b>Unclassified - unlimited STAR Category 18</b>	
19. Security Classif. (of this report) <b>Unclassified</b>	20. Security Classif. (of this page) <b>Unclassified</b>	21. No. of Pages <b>36</b>	22. Price* <b>A03</b>

# MASS STUDY FOR MODULAR APPROACHES TO A SOLAR ELECTRIC

## PROPULSION MODULE

by G. Richard Sharp, James E. Cake, Jon C. Oglebay, and Francis J. Shaker

Lewis Research Center

### SUMMARY

A mass study is presented for two modular approaches to the design of a conceptual solar electric propulsion module. The propulsion module comprises six to eight 30-centimeter ion thruster and power processing units, a mercury propellant storage and distribution system, a solar array ranging in power from 18 to 25 kilowatts, and the thermal and structure systems required to support the thrust and power subsystems. The two modular approaches studied are a Thruster Subsystem Module (TSSM) and a Bimodular (BIMOD) unit. The TSSM consists of a 30-centimeter ion thruster and gimbal system, a propellant storage and feed system, a power processing unit, a supporting structure, and a louver/heat pipe/multilayer insulation thermal control system. The BIMOD consists of two thrusters and gimbal systems, two power processors, supporting structure, and a heat pipe/multilayer insulation thermal control system (with no louvers). A central propellant storage system is employed in the BIMOD propulsion module.

Launch and on-orbit configurations are presented for both the TSSM and BIMOD approaches to the propulsion module. The propulsion module satisfies the thermal design requirements of a multimission set including: Mercury, Saturn, and Jupiter orbiters, a 1-AU solar observatory, and comet and asteroid rendezvous. The launch environmental requirements are for the Space Shuttle/Interim Upper Stage. Details of the structural and thermal aspects of the design including dimensions and interfaces are given for both approaches. The design goal of minimizing the mass of the propulsion module structure is accomplished in part by supporting the propulsion module at both the propulsion module/spacecraft interface where the mercury propellant load is concentrated and by supporting the large solar array masses at the propulsion module/launch vehicle interface.

A detailed mass breakdown is given for both the TSSM and BIMOD approaches. For the TSSM approach, the mass of a six thruster, 18-kilowatt propulsion module is 706 kilograms and the mass of an eight thruster, 25-kilowatt propulsion module is 899 kilograms. There is no significant difference in the masses of the corresponding propulsion modules using the BIMOD approach. The mass of the propulsion module is transformed into a mass equation relating the total mass to the number of thrusters and solar array power requirement. This equation may be used by the mission analyst to determine the mission performance of the conceptual propulsion module.

## INTRODUCTION

In the past few years, the potential users of Solar Electric Propulsion (SEP) technology have proposed several SEP planetary missions and spacecraft design concepts for the 1980 decade. As the capability of the Space Shuttle/Interim Upper Stage (IUS), the launch vehicle for the 1980's, is defined, the users of the SEP technology will be updating the SEP performance capability for these missions and mission analysts will be examining new SEP mission applications and mission strategies. The mission analyst has traditionally (ref. 1) termed the initial or gross spacecraft mass as the sum of the net payload mass, the propulsion system mass, and the low thrust propellant mass. The net payload comprises the spacecraft engineering systems and the science payload. The propulsion system comprises the 30-centimeter ion thrusters and power processors, structure, propellant storage and distribution, thermal control, and the solar array system. That quantity which the mission analyst usually maximizes when determining optimum SEP trajectories is the mass of the net payload that is delivered to the rendezvous target of a comet or asteroid or that is injected into orbit about a planet. The only mass quantity which is of particular interest to the scientist is the science payload. This mass is defined as the net payload mass minus the engineering systems mass. For some missions, the science payload available may be as low as 5 percent of the initial spacecraft mass. This figure is lower than most mass contingencies used in preliminary spacecraft design studies. Therefore a detailed and accurate mass breakdown for the engineering systems and propulsion system is required so that the science payload mass may be determined with a high degree of confidence.

Mass studies have been performed for a propulsion system design where the elements of the thrust subsystem (thrusters, power processors, support structure, and tankage) have been individually integrated into the spacecraft (refs. 2 to 5). In those studies conducted by the Jet Propulsion Laboratory, the propulsion system together with power transfer and distribution components and mechanisms, was termed a Solar Electric Propulsion Module (SEPM). The objective of this report is to present the results of a mass study for a conceptual propulsion module design which uses two "building block" or modular approaches in integrating the elements of the thrust subsystem into a SEPM.

The use of modules in an on-going series of SEP missions would accrue many benefits. A qualification test program for the thrust modules could be developed that would envelop the mission set. Since essentially identical modules could be used for several on-going missions, only a flight acceptance test program would need to be performed on the modules to be used for each mission. It would thus be possible to use the flight spares of one mission as the flight units of the following mission thus effecting a large cost savings. Reliability of the on-going missions would be greatly enhanced

since virtually identical hardware would be used.

Past studies (refs. 5 to 8) have shown that most of the SEP missions presently under consideration can be flown by a six to eight thruster configuration. Configuration and reliability studies (refs. 3 to 5) have also shown a  $2 \times n$  configuration matrix (i. e., arranged in pairs) of these six ( $n = 3$ ) to eight ( $n = 4$ ) thrusters to be a logical choice. Both of the modular approaches studied in this report lend themselves to forming a  $2 \times n$  configuration matrix of ion thrusters.

The first design concept, termed a Thruster Subsystem Module (TSSM) and proposed in reference 9, consists of a 30-centimeter ion thruster, a thruster gimbal system, a propellant storage and feed system, a Power Processing Unit (PPU), a modular thermal control system, and a modular support structure. The individual Thruster Subsystem Modules (TSSM) are then assembled and integrated into the propulsion module in a  $2 \times n$  configuration. The design approach to the TSSM in this report represents a refinement of the approach presented in reference 9.

The second "building block" approach proposed herein is termed a Bimodular (BIMOD) unit, and consists of two ion thrusters and gimbal systems, two PPU's, a common thermal control system, and a support structure. The BIMOD units are then assembled for the  $2 \times n$  thruster configuration. A single central mercury propellant tank system is used in this approach.

Because of the need for accurate masses of the spacecraft as explained earlier, the two competing modular thrust subsystem designs and all interconnecting and support structures of the conceptual propulsion module were studied in detail. By considering the overall launch configuration of the entire spacecraft, and then performing structural static and dynamic analyses of the modules, the required degree for accuracy for masses was obtained.

This report first defines the elements of the conceptual propulsion module and then shows schematically how the TSSM and BIMOD submodules would form a propulsion module configuration of six or eight ion thrusters and power processors. The form of a mass equation is first given for the conceptual propulsion module, where the independent variables of the mass equation are the number of TSSM or BIMOD submodules and the solar array power in kilowatts. The coefficients of the mass equation are determined from the mass contribution of the submodules, support structure and components, and the solar array system. The design approach and design requirements of the TSSM and BIMOD submodules are then reviewed with particular emphasis on the assumptions and considerations given to integrating the submodules into the particular propulsion module concept. The thruster and gimbal system, the propellant distribution system, the power processing unit, the thermal control system, and the submodule structure are described for both the TSSM and BIMOD approaches. A detailed mass breakdown on the component level is given for each submodule, the interface truss

between the propulsion module and the payload, the solar array system and components mounted within the interface truss.

The TSSM system and BIMOD system mass totals are used to determine the coefficients of the mass equation. The resulting mass equations formed for the TSSM and BIMOD approaches to the conceptual propulsion module may then be used by the mission analyst to determine: the mission performance (net payload mass) for a propulsion module with a given number of ion thrusters and solar array power; and the available science payload mass for a particular mission.

## PROPULSION MODULE CONFIGURATION

The major systems of a typical spacecraft using solar electric propulsion are shown in the block diagram of figure 1. These systems include science payload; the engineering systems such as communications, data handling, central computers, house-keeping power bus, and attitude control; the solar array system; and components of the thrust subsystem. The thrust subsystem consists of the 30-centimeter ion thrusters and gimbal systems, power processing units, mercury propellant storage and distribution systems, thermal control and supporting structure, power transfer and distribution components, and mechanisms. Three elements that are shown in the figure are not considered systems but are part of the gross left off mass. These include the expendables of reaction control propellant and mercury propellant and the launch vehicle adapter which remains with the launch vehicle.

In the spacecraft design studies conducted by the Jet Propulsion Laboratory (ref. 3) all of the aforementioned systems were integrated into two separate modules, called a propulsion module and a mission module. The term propulsion module as used in this report is defined in figures 2 and 3. A modularized thrust subsystem is used to form a six or eight thruster propulsion module. These submodules form a package which in turn is fastened to an interface truss (fig. 3) between the package and the rest of the spacecraft (e. g., mission module). Some components of the thrust subsystem are mounted within the interface truss. The third element of the propulsion module is the solar array system. This definition of the propulsion module is consistent with that used in reference 3, with the exception that the reference 3 definition includes attitude control components.

The unimodular concept for the submodules, termed a TSSM (fig. 4(a)) consists of one thruster and gimbal system, a power processor, a propellant storage and distribution system, and a modular thermal control system and support structure. The bimodular concept (fig. 4(b)) consists of two thrusters and gimbal systems, two power

processors, a common thermal control system, and a common structure. The BIMOD concept employs a single remote propellant storage system within the interface truss rather than in the submodule, as in the TSSM.

The number of submodules selected to integrate into the propulsion module is determined from the mission requirements specified by the users of SEP technology. Current missions under consideration include comet and asteroid rendezvous; Saturn, Jupiter, and Mercury orbiters, and a 1-AU solar observatory. From references 5 and 7, the number of ion thrusters required to accomplish these missions ranges from six to eight. Therefore, for the TSSM approach to the six thruster propulsion module, six modules are bolted together as shown in figure 5(a) to form a two-by-three matrix of thrusters. For the BIMOD approach to the propulsion module, three modules are used as shown in figure 5(b) to form the two-by-three matrix of thrusters.

The mass equation for the propulsion module (SEPM) is of the following form:

$$M_{SEPM} = M_{THRUST\ SUBSYSTEM} + M_{SOLAR\ ARRAY}$$

where  $M$  is the mass in kilograms. This equation may be expressed in the following form:

$$M_{SEPM} = K_1 N_{SM} + K_2 P_0 + K_3$$

where  $N_{SM}$  are the number of submodules (TSSM's or BIMOD's) used in the propulsion module and  $P_0$  is the solar array beginning of life power in kilowatts. The coefficients  $K_1$ ,  $K_2$ , and  $K_3$  will be determined for both the TSSM and BIMOD approaches.

## DESIGN APPROACH AND REQUIREMENTS

### General Design Approach

The goal of the design feasibility study of the TSSM and BIMOD submodules was to minimize the mass of the structure for both the submodules and the interface truss which supports the submodules. To accomplish this goal, a method was selected for integrating a solar array system with the thrust subsystem to form the propulsion module and for supporting the entire SEP spacecraft with the launch vehicle adapter. Both of these criteria have a great effect on the design of the thrust subsystem structure and ultimately the total mass.

It was assumed that the user of SEP technology would design a spacecraft using a

solar array system based on the current technology typified by the 25-kilowatt SEP Solar Array System described in reference 10. The solar array is a foldout design extended via a deployable mast. Figure 6 shows the relation of the thrust subsystem, the solar array system, and the launch adapter tower assumed in this study. The centerline of the mercury propellant tankage will be near the center of mass of the SEP spacecraft. The launch adapter, which bolts to the IUS-spacecraft interface, supports the entire spacecraft with the exception of the solar arrays at support points on the interface truss (fig. 6). These support points are located in a horizontal plane near the center of mass of the assembled spacecraft thereby reducing member forces caused by lateral inertia forces. This design approach provides a savings in weight.

Another weight saving feature of this design is that the solar array masses are primarily supported at the IUS-spacecraft interface. This allows for a lighter launch adapter truss since the solar array mass inertial loads are not carried by this truss. Also, because the launch loads of the solar arrays mass do not influence the design of the TSSM and BIMOD submodules, the submodule structural masses are also lighter. This effects a large mass savings in the overall fly-away mass of the spacecraft structure.

In the launch configuration the solar array deployment booms, which would swing out  $90^{\circ}$  for deployment, could transfer spacecraft launch loads to the stowed solar array structure. Therefore it would be necessary to design the booms so that they cannot transmit a compressive load when stowed. This is accomplished by designing a spring loaded telescoping section into the booms.

### Thermal Design Requirements

For the spacecraft configuration under consideration, figure 7 shows that the PPU typically rejects heat from the outboard and solar array facing surfaces. Therefore, the PPU thermal design must be compatible with the thermal influence of the solar arrays. The spacecraft is assumed to be oriented so that there is no appreciable solar flux incident on the radiative faces of the PPU's.

The SEP mission and PPU thermal environmental requirements are listed in table I. Typical PPU electrical component temperature limits to ensure high reliability are  $-15^{\circ}$  to  $85^{\circ}$  C operating temperature and  $-50^{\circ}$  to  $100^{\circ}$  C nonoperating temperatures. Since it is desirable to operate the components below the  $85^{\circ}$  C maximum, an operating temperature of  $75^{\circ}$  C was selected. Assuming the components, in general, have a junction to base temperature difference of  $24^{\circ}$  C yields the baseplate temperature of  $51^{\circ}$  C shown in table I. A temperature difference of  $1^{\circ}$  C was assumed between the PPU baseplate and heat pipe radiator. The basic PPU package thermal design is thermally independent



from other spacecraft components in order to simplify the overall thermal design. The governing condition for the thermal control system design for either the TSSM or the BIMOD is the high solar array temperature at 0.3 AU. This condition assumes that the array is tilted  $80^{\circ}$  from the sun at 0.3 AU. The array power output level at 0.3 AU with the  $80^{\circ}$  tilt is the same power level at 1 AU with zero degree tilt.

### Structural Design Requirements

To determine the structural member sizes and subsequent weights of the various components comprising the module and also the launch adapter the launch load requirements of the Shuttle/IUS launch vehicle (refs. 11 and 12) were used. These launch load requirements were multiplied by the ultimate (1.4) and yield (1.1) factors of safety to generate the ultimate and limit design loads shown in table II. The coordinate system used in this table is shown in figure 6.

In addition to the quasi-static loading conditions a minimum frequency requirement was also imposed. The purpose of this was to minimize the amplifications of the Shuttle/IUS induced mechanical vibrations. The minimum allowable structural frequency of the spacecraft was assumed to be 5 hertz. According to available Shuttle/IUS information to date this frequency requirement appears reasonable, although the actual requirement will be specified at some future date.

### Thruster Gimbal System Requirements

The required distance between thruster centerlines is 0.6 meter. Table III lists the approximate thruster gimbal angle requirements to align the outboard thruster through the spacecraft center of mass. The slew rates and additional gimbal travel angle required for attitude control are to be determined by the user of SEP technology.

## THRUST SUBSYSTEM MODULE APPROACH

### General Description

The TSSM approach to a propulsion module design was first proposed in reference 9. The conceptual propulsion module design employing the present TSSM configuration is shown in figure 8. The major elements of the propulsion module are the package of eight TSSM's, the interface truss between this package and the rest of the

SEP spacecraft, and the solar array which attaches to the interface truss. Expanding the categories of figure 2, figure 9 shows the equipment tree for the TSSM approach to the propulsion module.

For normal spacecraft operation with the sun perpendicular to the array longitudinal axis, there is no solar incidence on the radiating face of the PPU. Heat that cannot be radiated to space directly through the louver system is conducted by heat pipes to an adjacent space facing radiator. A single TSSM is shown in figure 10.

Figures 11 and 12 present an end view and side view, respectively, of the propulsion module in the launch configuration. Following the general design approach, the propellant tank and PPU of each TSSM are located near the solar array centerline or total vehicle mass center, and the ion thruster is located at the opposite end of the submodules. The distances between the centerlines of thrusters of adjacent submodules is 0.6 meter. The height of the propulsion module above the Shuttle/IUS adapter is 3.05 meters. The TSSM structure is a lightweight truss constructed of graphite reinforced plastic (GRP) tubes which are inserted into GRP end fittings. Figure 11 shows that the adjacent TSSM trusses are bolted to each other at a single point. As shown in figure 8, each TSSM is bolted to the interface truss at two points adjacent to the base of the PPU. Although the details are not shown on this figure, electrical and propellant line connections are made at this interface.

The entire spacecraft is separated from the IUS by first firing the separation devices at the four launch adapter support points shown in figures 8 and 12. The four launch adapter tower segments then pivot about their hinged bases in flower petal fashion to swing clear of the spacecraft. As the adapter tower swings clear, the solar array deployment booms immediately extend about 2 inches to their stops, thus leaving the spacecraft attached to the IUS only at the solar array blanket containment box (fig. 12). When the separation devices at the solar array/IUS interface are fired, the spacecraft will safely separate from the IUS using small ejection springs at the solar array/IUS interface.

When the spacecraft is a safe distance from the IUS, the solar array deployment boom lock (fig. 11) is released, allowing the solar array booms to swing  $90^{\circ}$  and latch in the final deployed configuration (fig. 8). The foldout solar arrays can now be deployed in their normal manner. Because the telescoping section solar array booms have extended to solid stops, they provide increased stiffness, thereby increasing the total solar array system natural frequency.

Using entries corresponding to those of the equipment tree in figure 9, table IV presents a detailed mass breakdown for the submodules and interface truss of the conceptual propulsion module using TSSM's. The mass table for the solar array system will be presented later. For each entry, the table first lists the contribution to the mass equation where  $N_1$  is the number of submodules in the propulsion module, fol-

lowed by the mass contribution for a six and eight thruster propulsion module. The masses of the thruster, power processor, and interface truss components were taken from current information. A level of detail beyond that provided in figure 9 was used to calculate the masses of the structural and thermal entries. For example, the masses of the truss tubes, end fittings, and attach hardware was calculated from the dimensions provided in individual drawings of these elements.

### Thruster and Thruster Gimbal System

The thruster utilized in the TSSM is the 900 series mercury ion thruster of 30-centimeter nominal anode (and beam) diameter. The thruster gimbal system uses linear actuators because of their light weight and inherent simplicity. An adapter structure between the thruster and the gimbal system is included as a part of the gimbal system. The gimbal system is capable of tilting the thruster  $\pm 40^\circ$  parallel to the length of the coupled TSSM's and  $\pm 20^\circ$  perpendicular to the PPU radiators. Comparing the total travel angle to the center of mass alignment requirements given in table III for an eight-thruster propulsion module indicates that approximately  $10^\circ$  travel angle remains in each axis for the attitude control function. The masses of the thruster and thruster gimbal system are listed in table IV. The thruster adapter mass accounts for 0.68 kilogram of the total gimbal system mass.

### Propellant Storage and Distribution System

Each TSSM has an individual propellant storage tank and propellant line feeding the thruster of the TSSM. The storage tanks are also cross coupled to the other TSSM's by a common manifold in order to equalize propellant utilization and increase the system reliability. The storage tank is sized for 122 kilograms of mercury. For a six TSSM propulsion module, the total propellant capacity is 732 kilograms. This value is sufficient for the comet, asteroid, and outer planet orbiter missions under study. The propellant tanks are nearly filled, thus alleviating the propellant slosh caused by launch acceleration. A nitrogen pressurized propellant expulsion system is employed to feed the propellant to the thruster with sufficient pressure to satisfy the thruster vaporizer requirements. The mass of the total propellant storage and distribution system listed in table IV includes the empty storage tank, two fill valves, a pressure transducer, a solenoid latching valve, three field joints, and the propellant lines including flexline. The propellant tank and line residual entry of the table assumes that 2 percent of the propellant capacity remains in the tank.

## Power Processing Unit

The PPU's being developed for the 30-centimeter ion thruster employ a packaging concept discussed in reference 13 and shown in figures 13 and 14. The power processor consists of seven cross-beam modules for mounting electrical components and a back plate which connects the modules and supports the module interconnect harness. This assembly is bolted to an outer frame that is a part of the TSSM as shown in figure 14. Heat pipe evaporator saddles, edge spacers, and louvers are then bolted directly to the faces of the PPU modules. This packaging concept compresses the PPU into a relatively small package (approximately 0.15 by 0.46 by 0.86 m). This compact package lends itself to the general design approach discussed earlier of concentrating the large mass components near the solar array centerline and launch adapter tower pickup. The mass of the PPU is listed in table IV.

## Thermal System

The thermal control system for the TSSM concept (fig. 8) consists of a combination of louvers, a variable conductance heat pipe system (VCHPS), a radiator fin, and multilayer insulation. A list of the thermal assumptions used for the TSSM are given in table V for the worst case condition analyzed (0.3 AU).

The electrical components of the PPU are mounted on individual z-section cross-beam modules. Physically large components and/or high thermal dissipation electrical components are mounted directly on the radiating (outboard or space facing) flanges of the z-section cross beams. The radiating flanges are then bolted directly to the evaporator saddles of the VCHPS. Components with the largest thermal dissipations are mounted close to the evaporator saddles. Components with lower thermal dissipations and printed circuit cards are mounted to the cross-beam webs. The single-sided louver radiating area is 0.61 by 0.89 meter. As shown in figure 13, two heat pipes are attached to each VCHPS saddle, with the second pipe being redundant. Waste heat in excess of the capacity of the louvered radiating area is conducted by the heat pipes to a remote thermally isolated 0.10-centimeter-thick aluminum single-sided radiator. The heat pipe radiator is located 0.1 meter from the base of the PPU and measures 0.61 by 0.74 meter. The thruster face and the ends of the TSSM propulsion module are wrapped with multilayer insulation. The thermal control system weight estimates were made using the values given in table VI.

## Structure

The main structural components of the conceptual propulsion module comprising TSSM submodules are shown in figure 8. As depicted in this figure each individual TSSM consists of a propellant tank and a thruster which are supported by truss-type structures. These trusses are attached to hard points on the PPU thus forming a completely rigid space truss capable of sustaining loads in all directions. In the launch configuration the interface truss supports the entire spacecraft except for the solar arrays by attaching to the Shuttle/IUS adapter via a launch adapter tower as shown in figures 11 and 12. It can be observed from these figures that the launch loads imposed by the solar array are transferred directly to the Shuttle/IUS adapter through the solar array support truss and not through the spacecraft structure. This in effect allows for a lighter spacecraft design.

Standard methods of structural static and dynamic analysis were employed to determine the TSSM, interface truss, and launch adapter tower truss member sizes. The members were first sized for the quasistatic loads given in table II. In the initial iteration the weights of the structural members were neglected and the payload weight was assumed to be 454 kilograms. The other component weights (propellant, thrusters, thermal control, etc.) used are shown in table IV. The truss members were sized for one of three conditions; column buckling, local crippling, or minimum gage. After completion of the static analysis, all member sizes were known, and a dynamic analysis was then performed to determine the fundamental frequency of the spacecraft in the launch configuration. It was found that the lowest frequency was primarily a function of the launch adapter tower stiffness and to achieve the minimum frequency requirement the tower stiffness had to be increased by increasing the cross-sectional area of its members. All other spacecraft members had sufficient stiffness to achieve the minimum frequency requirement of 5 hertz.

For weight saving purposes all major structural members of the trusses and launch adapter were assumed to be made from graphite composite tubing. Both magnesium end fittings and graphite composite joints for the trusses were examined. The graphite composite joint showed a slight weight advantage over the magnesium end fitting. Mechanical properties for the graphite tubing were conservatively assumed to be the following: Young's modulus of  $1.24 \times 10^{11}$  N/m<sup>2</sup>; ultimate strength of  $2.34 \times 10^8$  N/m<sup>2</sup>; and yield strength of  $3.93 \times 10^8$  N/m<sup>2</sup>.

The tube diameters and wall thickness are given in table VII for the TSSM truss, the interface truss, and the launch adapter tower. The launch adapter tower mass was determined to be 47 kilograms.

## Interface Truss Components

In addition to the interface truss structure, table IV also lists the masses for the components mounted within or on the interface truss and the miscellaneous hardware considered as part of the truss. The components include the raw power distribution assembly which distributes the raw solar array power to the individual power processors, and a preregulator assembly which converts the input array voltage of 200 to 400 volts to a reduced bus voltage for the spacecraft engineering subsystem. The TSS controller is a computer used for control of the thrust subsystem. The masses of these three components are from reference 3. Component shelves, shelf stiffeners, interface truss compartment and component thermal control, solar array drive brackets, and spacecraft attach hardware are also included in the table. The power harness includes the harness required from the raw power distribution to the individual power processors.

## Solar Array System

As mentioned in the section General Design Approach, the solar array system employed in the conceptual propulsion module is based on the current 25-kilowatt SEP solar array technology. It was assumed that the 25-kilowatt array blanket containment box and deployable mast canister would be used for array power requirements between 18 and 25 kilowatts. Scaling of the array to a power less than 25 kilowatts would be accomplished by decreasing the length of the array blanket but maintaining the same array blanket width. Table VIII presents the mass breakdown for the complete solar array system. The mass of the solar array from reference 10 is divided into a fixed mass component of the array mast canister, structure, mechanisms, and blanket leader and a second mass component of array blanket, mast elements, and harness which varies with solar array power. The mass of the solar array deployment boom includes the mass for a spring that forces the telescoping boom sections to extend until they come against stops and thus provide adequate boom stiffening when the arrays are deployed. The data for the solar array drive and electronics is from reference 14. The power harness mass is for a harness that runs from the base of the solar array to the raw power distribution assembly within the interface truss.

# BIMODULAR APPROACH

## General Description

The Bimodular (BIMOD) approach to the conceptual propulsion module design is shown in the on-orbit configuration in figure 15 and in the launch configuration in figure 16. The BIMOD is a thrust subsystem submodule incorporating two 30-centimeter ion thrusters with two PPU's. Following the general design approach, the large masses of the propellant distribution system and the PPU's are located near the solar array centerline and launch adapter tower support points.

The most significant difference in the BIMOD is the integration of the power processors and thermal control system into the submodule. As figures 15 to 17 indicate, the two power processors are mated to a common heat pipe system, and are interior to two remote single-sided radiators. There are no louvers required in this submodule design because the radiating flanges of the PPU are not directly exposed to space. The PPU package is identical to that used for the TSSM, although there could be differences in how the PPU's are attached to the heat pipe evaporator section. Unlike the TSSM, the mercury propellant for the BIMOD propulsion module is stored in a single tank mounted in the interface truss. The 732-kilogram propellant capacity of the single BIMOD tank is equivalent to the capacity of six individual TSSM tanks. The thruster and thruster gimbal systems for the BIMOD are identical to that previously described for the TSSM. The equipment diagram for the BIMOD approach to the propulsion module is shown in figure 18.

For the planet orbiter missions, the entire propulsion module would probably be jettisoned from the spacecraft before the spacecraft fires the retrostage for planetary orbit insertion. For missions to the outer planets where the useable solar array power decreases rapidly, there is insufficient power to operate all of the thrusters and therefore it may be advantageous to jettison mass along the trajectory and thereby increase the low thrust acceleration. A jettison system has been included in the design of the BIMOD so that the individual BIMOD may be jettisoned from its four attach points with the interface truss (fig. 15). The mass of jettison springs and additional multilayer insulation between BIMOD's has been included in the mass breakdown for the BIMOD propulsion module. Because of the preliminary nature of this jettison concept the propellant and electrical interfaces for jettisoning have not yet been established and additional masses have not been included for them.

The mass breakdown for the BIMOD approach to the propulsion module is given in table IX. The interface truss components as well as the solar array system are identical to those used in the TSSM approach.

## Thermal System

Exploded views of the BIMOD assembly are shown in figure 19. For the BIMOD assembly, the high heat dissipation flanges of the power processor are also bolted directly to the heat pipe evaporator saddles. This is accomplished by having the PPU back plate interconnect removed during the installation and using blind fasteners. Figure 19 shows three heat pipes on each of the two heat pipe saddles. The power processor designated A in figure 19 is the top power processor of figure 15. The A3 and A4 modules of the PPU contain the large thermal dissipation components of the power processor, with the highest heat dissipation components of PPU A on or near the heat pipe saddle A of figure 19. Because of the inverted orientation of PPU B, its high thermal dissipation components of the A3 and A4 modules are now located on or near heat pipe saddle B. With this orientation, the heat loads going into each of the two heat pipe saddles are equal when both PPU's are operating. Figures 15 and 19 illustrate that one heat pipe of saddle B and two heat pipes of saddle A are extended to the one heat pipe radiator. The remaining three heat pipes are capped on the near side of the PPU but extend to the radiator on the far side of the propulsion module. The heat pipes are sized such that adequate heat transfer to the radiator is provided should one heat pipe of each saddle fail. A list of the thermal assumptions used for the BIMOD are also given in table V.

In the BIMOD configuration, the PPU's are unable to radiate any heat directly to space and, therefore, the total heat load must be dissipated by the heat pipe radiators. This requires that the heat-pipe radiator area be larger than in the TSSM configuration. The radiator for each PPU in the BIMOD configuration measures 0.61 by 1.88 meters. Again, as an additional safety factor, the 1.88-meter length is 25 percent larger than the required length calculated when using the 72 percent radiator efficiency shown in table V.

## Structure

The primary structural components of a conceptual propulsion module comprising BIMOD submodules are depicted in figure 15. For this case each individual submodule consists of two engines supported by a truss-type structure attached to hard points on the PPU outer frame. Each of these submodules is attached to the nodes of a rigid interface truss, which also houses the single propellant tank. In addition the interface truss supports the solar arrays and the payload in the flight configuration. In the launch configuration the BIMOD propulsion module is supported in a manner (fig. 16) similar to the TSSM conceptual propulsion module (fig. 6). Therefore, the remarks



made concerning the TSSM concept in the launch configuration are also applicable to the BIMOD concept. The truss member sizes for the BIMOD were determined using the same analysis techniques employed and described earlier for the TSSM. The member sizes used in the mass study for the BIMOD are identical to those given in table VII for the TSSM.

### MASS SUMMARY

The masses of the TSSM and BIMOD approaches to the conceptual propulsion module design are given in table X. The mass equation for the TSSM propulsion module is given by

$$M_{SEPM} = 57.05 N_1 + 11.29 P_0 + 160.80, \text{ kg}$$

where  $N_1$  is the number of TSSM submodules used in the propulsion module and  $P_0$  is the beginning of life solar array power required. The mass equation for the BIMOD propulsion module is given by

$$M_{SEPM} = 103.88 N_2 + 11.29 P_0 + 194.84, \text{ kg}$$

where in this equation  $N_2$  is the number of BIMOD submodules.

The table also lists total masses for a six thruster, 18-kilowatt solar array propulsion module; and eight thruster, 18-kilowatt solar array propulsion module; and an eight thruster, 25-kilowatt solar array propulsion module for both the TSSM and BIMOD approaches. As the table indicates, there is little difference in mass between the TSSM and BIMOD approaches.

### CONCLUDING REMARKS

The results of a detailed configuration and design study have been presented for two modular approaches to the design of a conceptual solar electric propulsion module. Emphasis has been placed on the mechanical and thermal integration of the 30-centimeter ion thrusters, power processors, thermal control system, structure, and propellant distribution system into two competing lightweight modules which are applicable to a multimission interplanetary set.

A detailed mass breakdown has been given for both the TSSM and BIMOD approaches. The mass of a six thruster, 18-kilowatt propulsion module is 706 kilograms for the TSSM approach and 710 kilograms for the BIMOD approach. The mass of an eight thruster, 25-kilowatt propulsion module is 899 kilograms for the TSSM approach and 893 kilograms for the BIMOD approach. The propulsion module masses were transformed into a mass equation relating the total mass to the number of thrusters and solar array power requirement. This equation may be used by the mission analyst to determine the mission performance of the conceptual propulsion module.

Lewis Research Center,  
National Aeronautics and Space Administration,  
Cleveland, Ohio, September 29, 1976,  
506-22.

#### REFERENCES

1. Electric Propulsion Mission Analysis - Terminology and Nomenclature. NASA SP-210, 1969.
2. Duxbury, John H.: An Integrated Solar Electric Spacecraft for the Encke Slow Flyby Mission. AIAA Paper 73-1126, Oct. 1973.
3. Duxbury, John H.: Solar Electric Propulsion Encke Slow Flyby 1979 Mission and Spacecraft Description. JPL-TM-701-200, Jet Propulsion Lab., 1974.
4. Duxbury, John H.: Interplanetary Spacecraft Design Using Solar Electric Propulsion - A Circular 1.0 A. U. Out-of-the-Ecliptic Mission. Laird European Electric Propulsion Conference, Cologne, Deutsche Gesellschaft Fuer Luft- and Raumfahrt, 1974, pp. 206-213.
5. Duxbury, John H.; and Paul, Gary M.: Interplanetary Spacecraft Design Using Solar Electric Propulsion. AIAA Paper 74-1084, Oct. 1974.
6. Sauer, Carl G., Jr.: Trajectory Design of a Solar Electric Propulsion Encke Slow Flyby Mission. AIAA Paper 75-421, Mar. 1975.
7. Atkins, Kenneth L.; and Duxbury, John H.: Solar Electric Propulsion Mission and Spacecraft Capabilities for Outer Planet Exploration. AIAA Paper 75-1158, Sept. 1975.
8. Dazzo, Edward J.; and Nagorski, Russell P.: Trajectory Analysis for Solar Electric Propulsion Stage (SEPS) Planetary Missions. AIAA Paper 73-1058, Oct. 1973.

9. Sharp, G. R.: A Thruster Sub-system Module (TSSM) for Solar Electric Propulsion. AIAA Paper 75-406, Mar. 1975.
10. Solar Array Technology Evaluation Program for SEPS (Solar Electrical Propulsion Stage). (LMSC-D384250, Lockheed Missiles and Space Co.; NAS8-30315) NASA CR-120483, 1974.
11. Level II Program Definition and Requirements. Volume 14 - Space Shuttle System Payload Accommodations. JSC-07700, Vol. 14, NASA Lyndon B. Johnson Space Center, 1975. (Available from NASA Johnson Space Center, Space Shuttle Program Manager.)
12. NASA Payload Requirements for IUS. NASA Marshall Space Flight Center. (Available from NASA Marshall Space Flight Center, STS Payload Requirements and Analysis Group.)
13. Maloy, J. E.; and Sharp, G. R.: A Structural and Thermal Packaging Approach for Power Processing Units for 30-Centimeter Ion Thrusters. AIAA Paper 75-403, Mar. 1975.
14. Proceedings of the 10th Aerospace Mechanisms Symposium. JP6-TM-33-777, Jet Propulsion Lab., 1976.

TABLE I. - REPRESENTATIVE SEP MISSIONS  
AND PPU THERMAL REQUIREMENTS

Mission	Mercury orbiter	1 AU	Jupiter orbiter
Distance from sun, AU	0.3	1.0	5.0
Solar array temperature, °C	80	50	-140
Heat pipe radiator temperature, °C	50	50	50
PPU baseplate temperature, °C	51	51	51
PPU thermal dissipations, W	277	277	324
PPU efficiency, percent	91.1	91.1	89.7

TABLE II. - LAUNCH VEHICLE DESIGN LOAD  
FACTORS BASED ON SHUTTLE/IUS

Flight event	Axis	Load factors, g	
		Ultimate	Limit
Shuttle load factors			
Maximum acceleration	X	<sup>a</sup> 4.7	3.7
Liftoff	Y	<sup>a</sup> ±1.4	±1.1
Landing	Z	<sup>a</sup> -4.0	-3.2
Emergency landing	X	<sup>b</sup> -9.0	----
	Y	<sup>b</sup> ±1.5	----
	Z	<sup>b</sup> 2.0	----
		<sup>b</sup> -4.5	----
IUS load factors			
Earth orbital	X	<sup>c</sup> 7.0	5.5
	Y	<sup>c</sup> ±4.2	±3.3
	Z	<sup>c</sup> ±4.2	±3.3

<sup>a</sup>Conservatively combined.

<sup>b</sup>Separated.

<sup>c</sup>Combined.

TABLE III. - THRUSTER GIMBAL

## ANGLE REQUIREMENTS FOR

## CENTER OF MASS

## ALINEMENT

Axis	6 Thrusters	8 Thrusters
y	$\pm 10^\circ$	$\pm 10^\circ$
z	$\pm 20^\circ$	$\pm 30^\circ$

TABLE IV. - MASS BREAKDOWN FOR THE SUBMODULES AND INTERFACE

## TRUSS OF A CONCEPTUAL PROPULSION MODULE DESIGN USING TSSM's

	Mass equation <sup>a</sup>	6 Modules, kg	8 Modules, kg
Thrust subsystem modules (total)	<sup>b</sup> $54.72 N_1 + 1.72$	330.01	439.48
Power processor	$24.86 N_1$	149.16	198.88
PPU thermal control	$8.65 N_1 + 2.0$	53.90	71.20
Thruster	$8.16 N_1$	48.96	65.28
Thruster gimbal system	$2.95 N_1$	17.70	23.60
Propellant storage and distribution system <sup>c</sup>	$4.50 N_1$	26.99	35.99
PPU to thruster harness	$0.54 N_1$	3.24	4.32
TSSM structure	$2.51 N_1 - 0.27$	14.79	19.81
Tank and line propellant residuals <sup>d</sup>	$2.55 N_1$	15.27	20.40
Interface truss (total)	$2.33 N_1 + 28.36$	42.34	47.00
Truss tubes, end fittings, TSSM attach points and hardware, solar array drive brackets	$1.83 N_1 + 3.76$	14.74	18.40
Truss and TSSM end insulation	$0.30 N_1 + 0.65$	2.45	3.05
Component shelf stiffeners, controller shelf, and attach brackets	1.90	1.90	1.90
Component thermal control	2.55	2.55	2.55
Raw power distribution	9.8	9.8	9.8
Preregulator	5.2	5.2	5.2
TSS controller	4.5	4.5	4.5
Power harness	$0.2 N_1$	1.2	1.6

<sup>a</sup>Units in kg.<sup>b</sup> $N_1$  = number of TSSM's.<sup>c</sup>Individual tank capacity of 122 kg; for tank capacity of 200 kg, add 1.07 kg/TSSM.<sup>d</sup>Add 1.56 kg/TSSM for tank capacity of 200 kg.

TABLE V. - GENERAL THERMAL CONTROL

ASSUMPTIONS

	TSSM	BIMOD
Solar array temperature, °C	80	80
Radiator temperature, °C	50	50
PPU baseplate temperature, °C	51	51
Solar array emittance	0.80	0.80
Louver emittance (fully open)	0.65	-----
Radiator emittance	0.88	0.88
Radiator efficiency, percent	72	72
Radiator view factor to space	0.83	0.83
Radiator view factor to solar array	0.17	0.17
Louver view factor to space	0.83	-----
Louver view factor to solar array	0.17	-----

TABLE VI. - THERMAL CONTROL SYSTEM WEIGHT FACTORS

Louver and louver supports, kg/m <sup>2</sup> . . . . .	5.27
Heat pipe gas reservoir, kg/reservoir. . . . .	0.215×10 <sup>-3</sup>
Heat pipe and saddle, kg/m. . . . .	0.014
Multilayer insulation, kg/m <sup>2</sup> . . . . .	0.47
Aluminum radiator and silver teflon, kg/m <sup>2</sup> . . . . .	2.93

TABLE VII. - TSSM TRESS TUBE SIZES

	Tube diameter, cm	Tube thickness, cm
TSSM	1.9	0.05
Interface	3.8	.13
Launch adapter	10.2	.23

TABLE VIII. - MASS BREAKDOWN FOR SOLAR ARRAY SYSTEM

	Mass equation	18-kW array, kg	25-kW array, kg
Array drive and electronics	9.1	9.1	9.1
Array deployment boom	12.16	12.16	12.16
Array root to truss harness	$0.27 P_0$	4.86	6.75
Array mast canister, structure, and mechanisms <sup>a</sup>	106.56	106.56	106.56
Array blanket leaders <sup>a</sup>	2.90	2.90	2.90
Array blanket, mast elements, and harness <sup>a</sup>	$11.02 P_0$	198.36	275.50
Total array system	$11.29 P_0 + 130.72$	333.94	412.97

<sup>a</sup>SEP solar array.

TABLE IX. - MASS BREAKDOWN FOR THE SUBMODULES AND INTERFACE TRUSS OF CONCEPTUAL PROPULSION MODULE DESIGN USING BIMOD'S

	Mass equation <sup>a</sup>	3 Modules, kg	4 Modules, kg
Bimodules (total)	<sup>b</sup> 97.87 N <sub>2</sub> + 1.30	294.91	392.78
Power processors (2)	49.72 N <sub>2</sub>	149.16	198.88
PPU thermal control	19.08 N <sub>2</sub> + 1.30	58.54	77.62
Thrusters (2)	16.32 N <sub>2</sub>	48.96	65.28
Thruster gimbal system (2)	5.90 N <sub>2</sub>	17.70	23.60
PPU to thruster harness	1.74 N <sub>2</sub>	5.22	6.96
BIMOD structure	5.11 N <sub>2</sub>	15.33	20.44
Interface truss (total)	6.01 N <sub>2</sub> + 62.82	80.87	86.86
Propellant storage and distribution system <sup>c</sup>	0.68 N <sub>2</sub> + 17.95	20.01	20.67
Tank and line Hg residuals	0.20 N <sub>2</sub> + 14.44	15.04	15.24
Tank support truss	2.12	2.12	2.12
Truss tubes, end fittings, BIMOD, attach points and hardware, solar array drive brackets	3.94 N <sub>2</sub> + 3.99	15.81	19.75
Truss insulation	0.79 N <sub>2</sub> + 0.49	2.86	3.65
Component shelf stiffeners, controller shelf, and attach brackets	1.90	1.90	1.90
Component thermal control	2.43	2.43	2.43
Raw power distribution	9.80	9.80	9.80
Preregulator	5.20	5.20	5.20
TSS controller	4.50	4.50	4.50
Power harness	0.40 N <sub>2</sub>	1.20	1.60

<sup>a</sup>Units in kg.

<sup>b</sup>N<sub>2</sub> = number of BIMOD's.

<sup>c</sup>Total capacity of 732-kg propellant. For 1500-kg capacity, add 13.11 kg.



TABLE X. - MASS EQUATION AND MASS SUMMARY FOR TSSM  
AND BIMOD SEPM

TSSM			
	Mass equation <sup>a</sup>	6 Modules, kg	8 Modules, kg
Submodules	$54.72 N_1 + 1.72$	330.01	439.48
Interface truss	$2.33 N_1 + 28.36$	42.34	47.00
Solar array	$11.29 P_0 + 130.72$	<sup>a</sup> 333.94	<sup>a</sup> 333.94 <sup>b</sup> 412.97
Totals	$57.05 N_1 + 11.29 P_0 + 160.80$	706.29	<sup>a</sup> 820.42 <sup>b</sup> 899.45
BIMOD			
	Mass equation	3 Modules, kg	4 Modules, kg
Submodules	$97.87 N_2 + 1.30$	294.91	392.78
Interface truss	$6.01 N_2 + 62.82$	80.87	86.86
Solar array	$11.29 P_0 + 130.72$	<sup>a</sup> 333.94	<sup>b</sup> 333.94 <sup>b</sup> 412.97
Totals	$103.88 N_2 + 11.29 P_0 + 194.84$	<sup>a</sup> 709.72	<sup>a</sup> 813.58 <sup>b</sup> 892.61

<sup>a</sup> $N_1$  is number of TSSM's required,  $N_2$  is number of BIMOD's required, and  $P_0$  is beginning of life (BOL) solar array power required in kW.

<sup>b</sup>18-kW BOL.

<sup>c</sup>25-kW BOL.

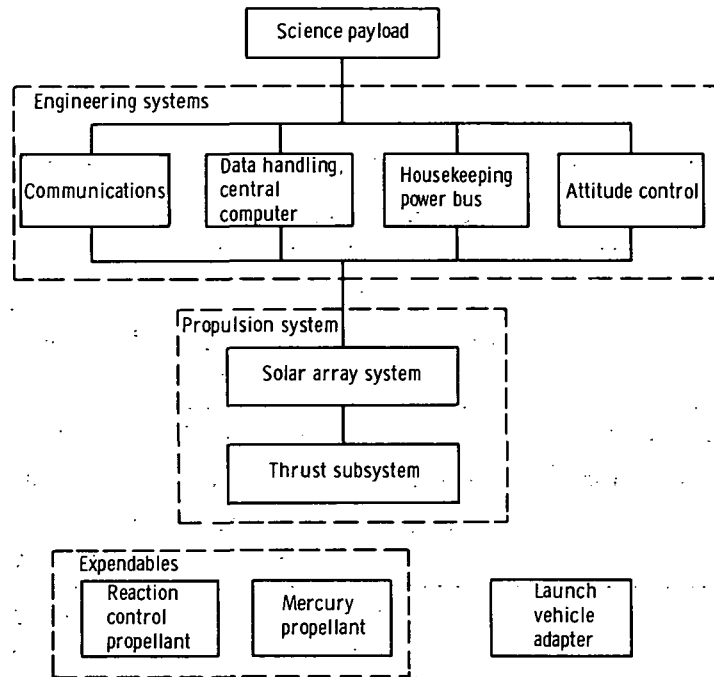

Figure 1. - Spacecraft systems block diagram.

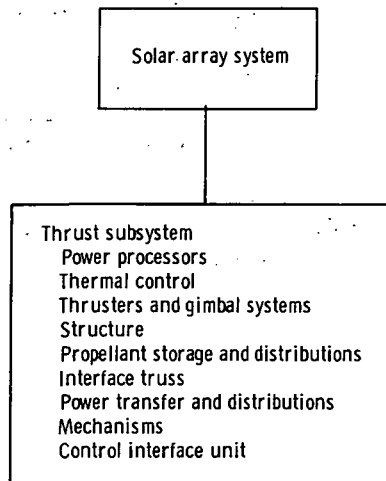

Figure 2. - Definitions of propulsion module for mass study.

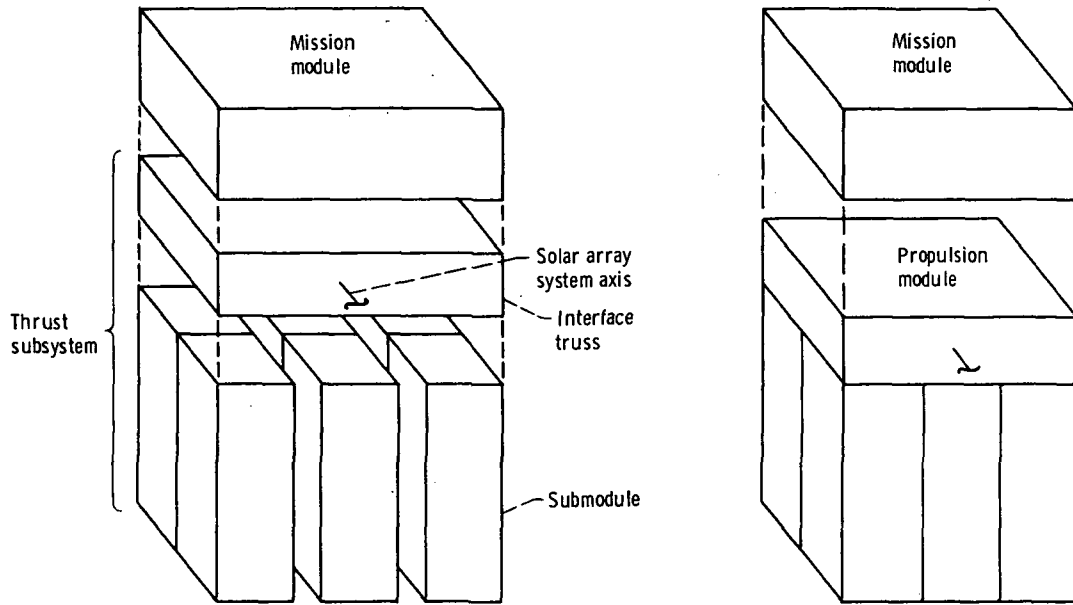
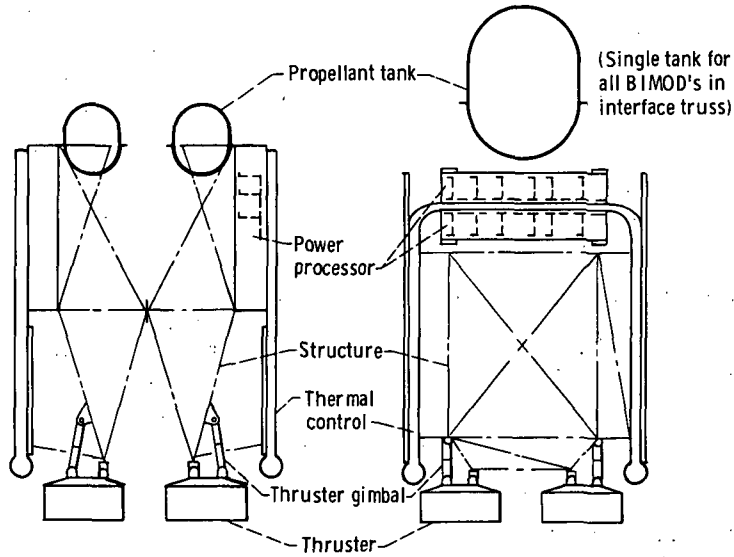

Figure 3. - Building block approach to propulsion module.



(a) TSSM approach (two shown).

(b) BIMOD approach.

Figure 4. - Comparison of TSSM and BIMOD submodules.

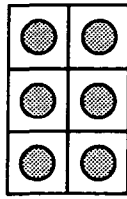

(a) TSSM approach.

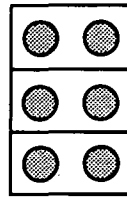

(b) BIMOD approach.

Figure 5. - Use of TSSM's and BIMOD's for six thruster matrix.

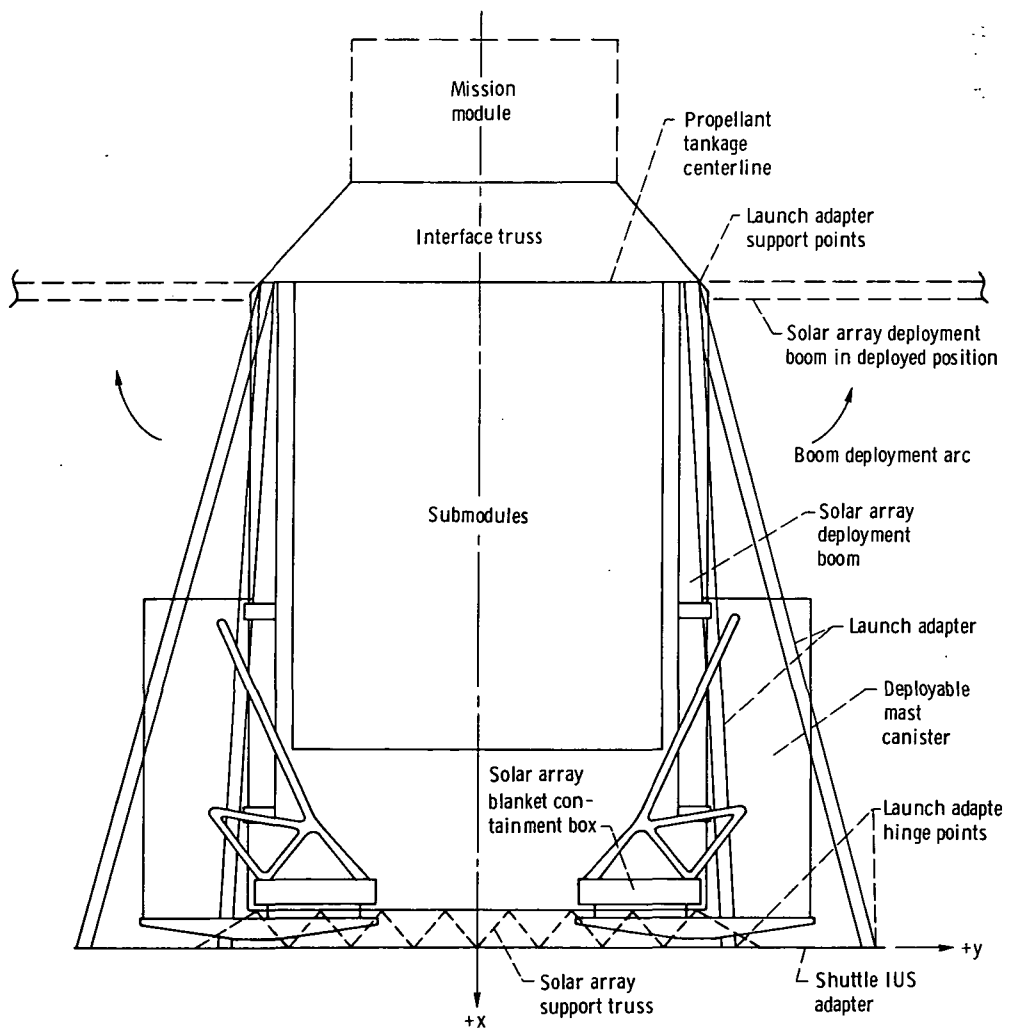

Figure 6. - General design approach.

Sunline  
↓

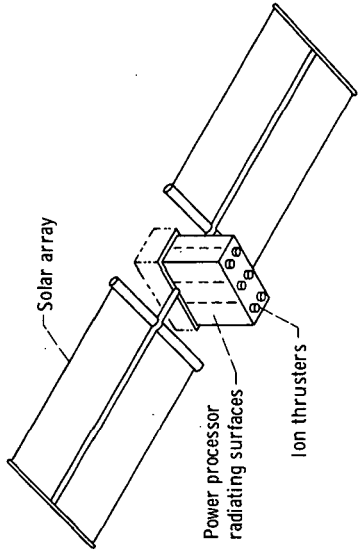

Figure 7. - Electric propulsion ion spacecraft.

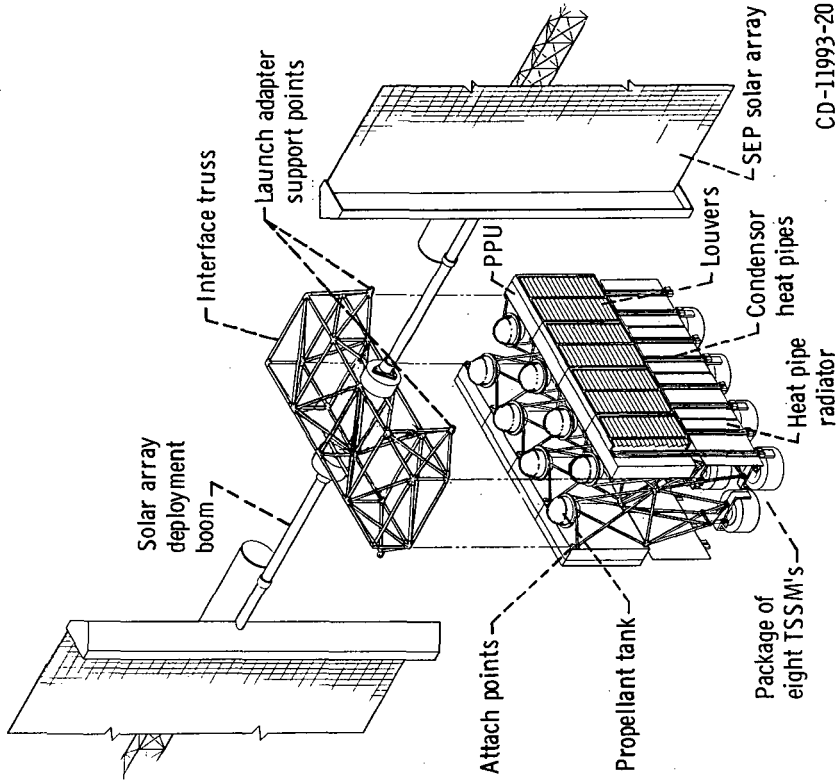

Figure 8. - Conceptual propulsion module using TSSM's.

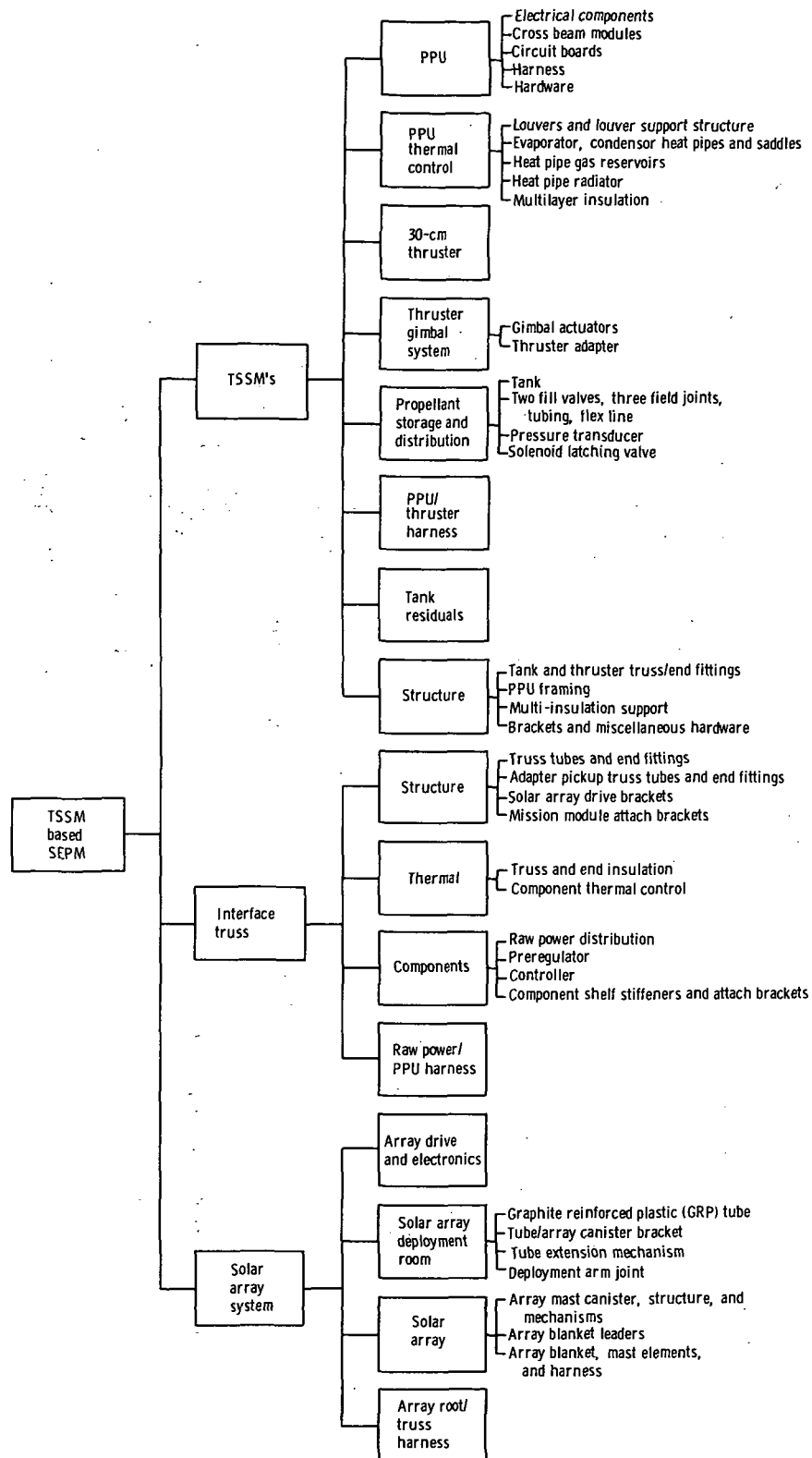

Figure 9. - TSSM based SEP equipment diagram.

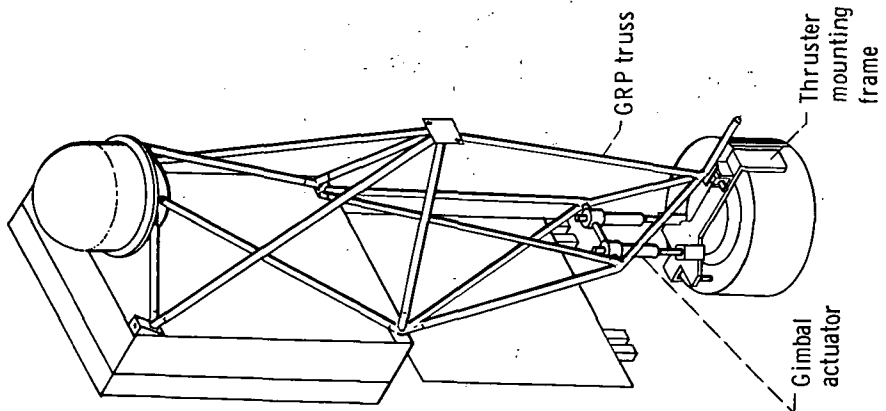

Figure 10. - Thruster subsystem module.

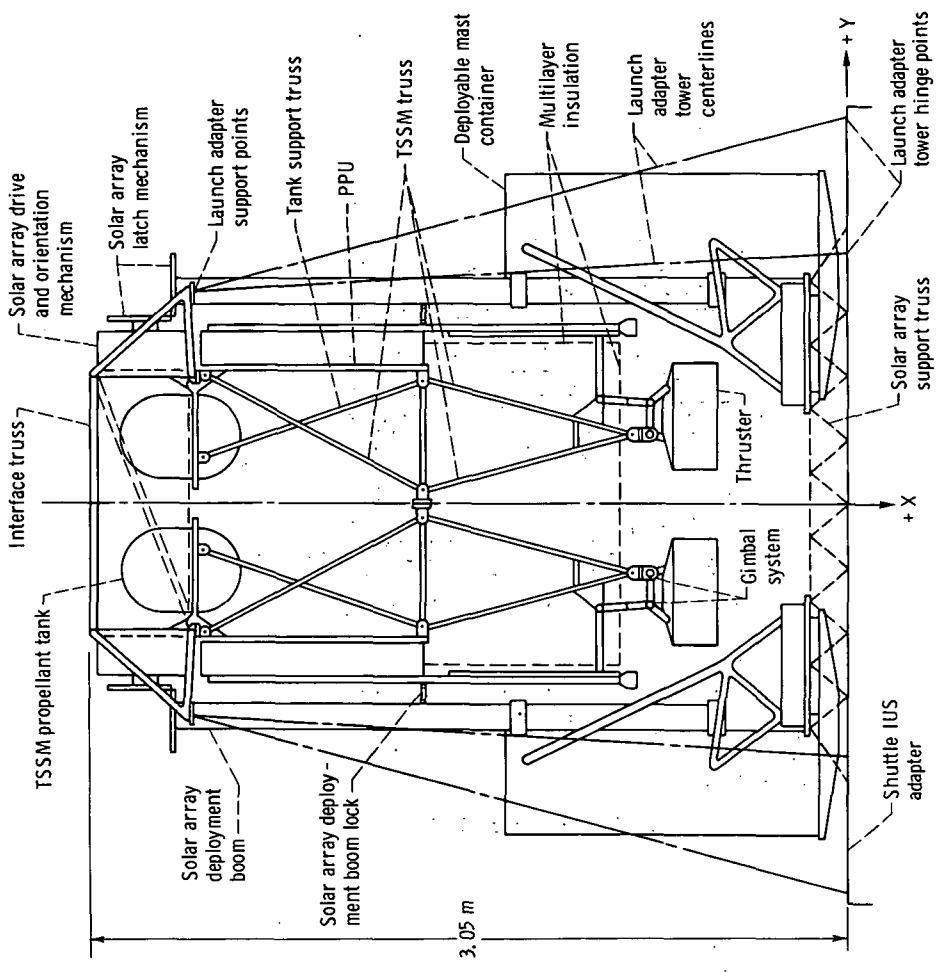

Figure 11. - End view of TSSM based SEPM.

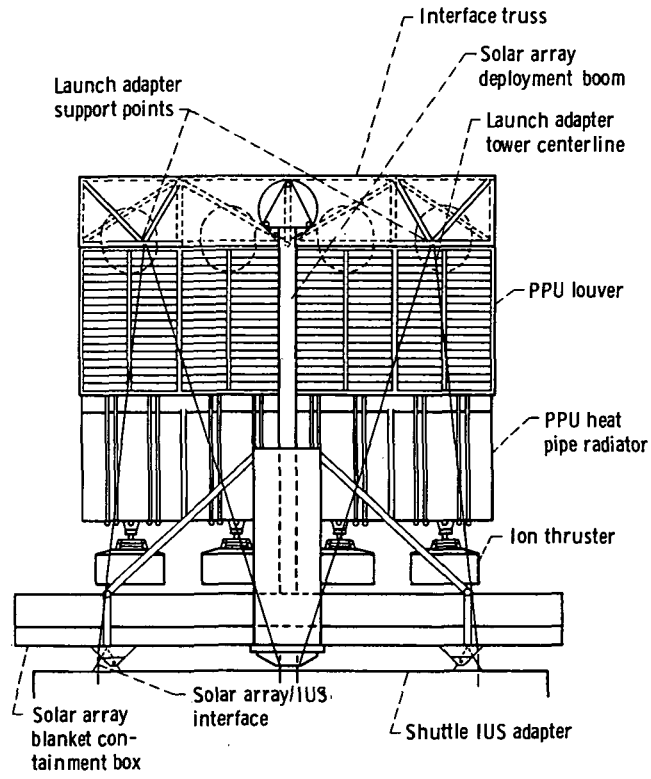

Figure 12. - Side view of TSSM based SEP.

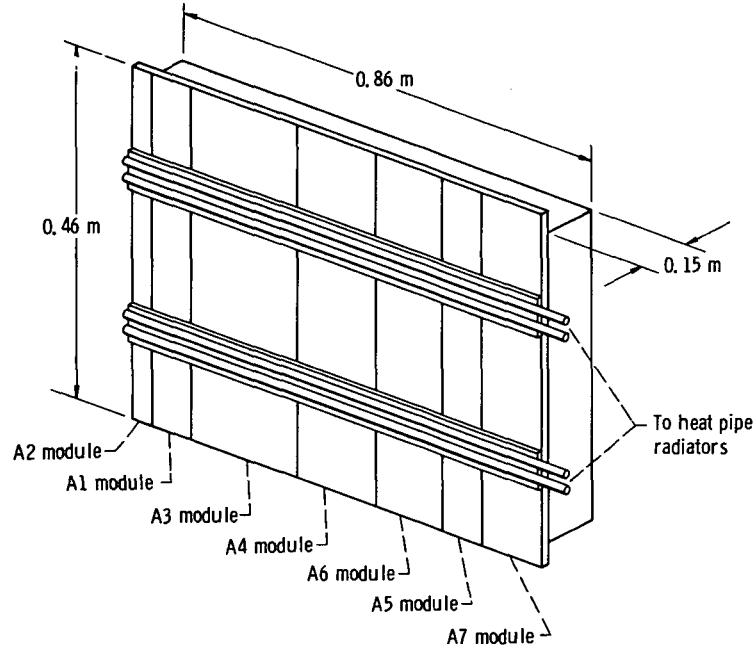

Figure 13. - Power processing unit.



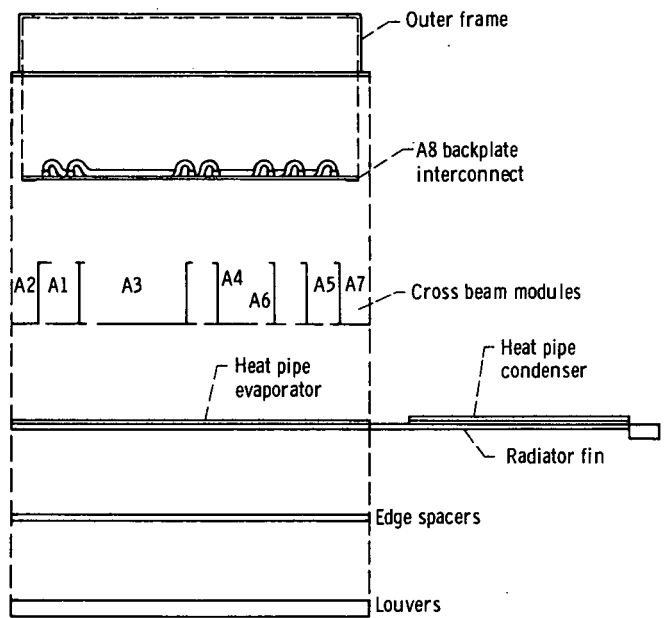
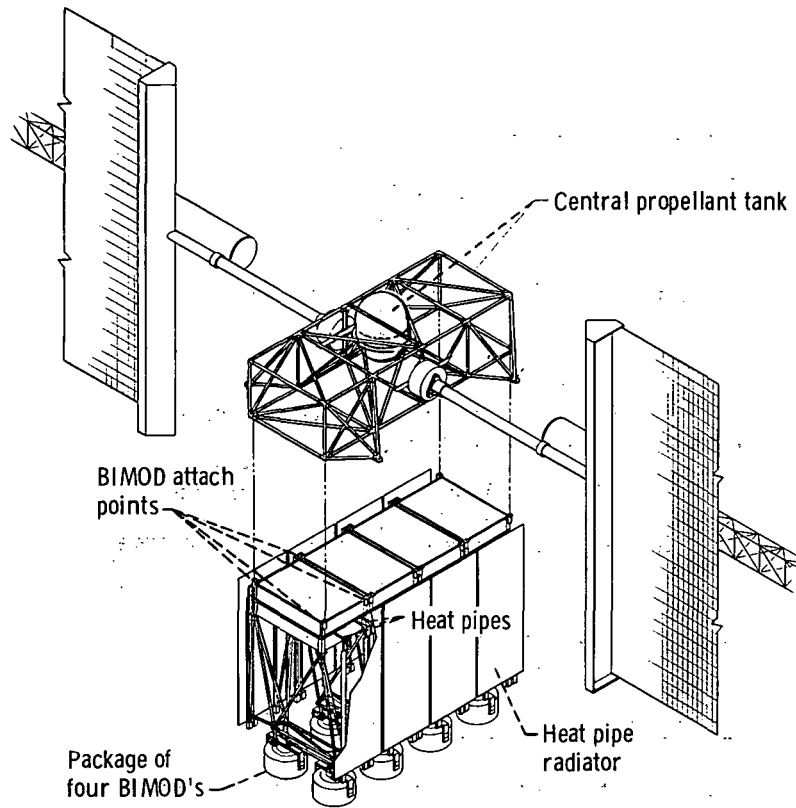

Figure 14. - Top view of exploded power processing unit - TSSM assembly.



CD-11994-20

Figure 15. - Conceptual propulsion module using BIMOD's.

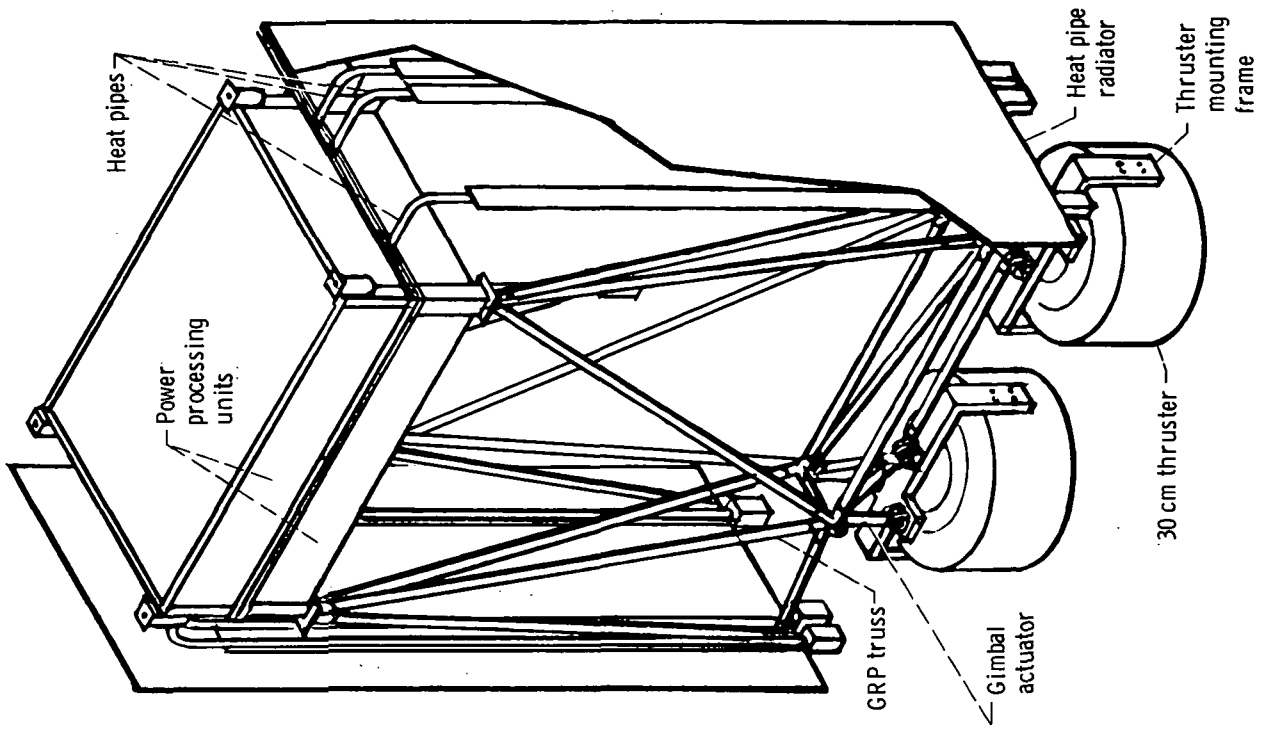

Figure 17. - Isometric view of BIMOD.

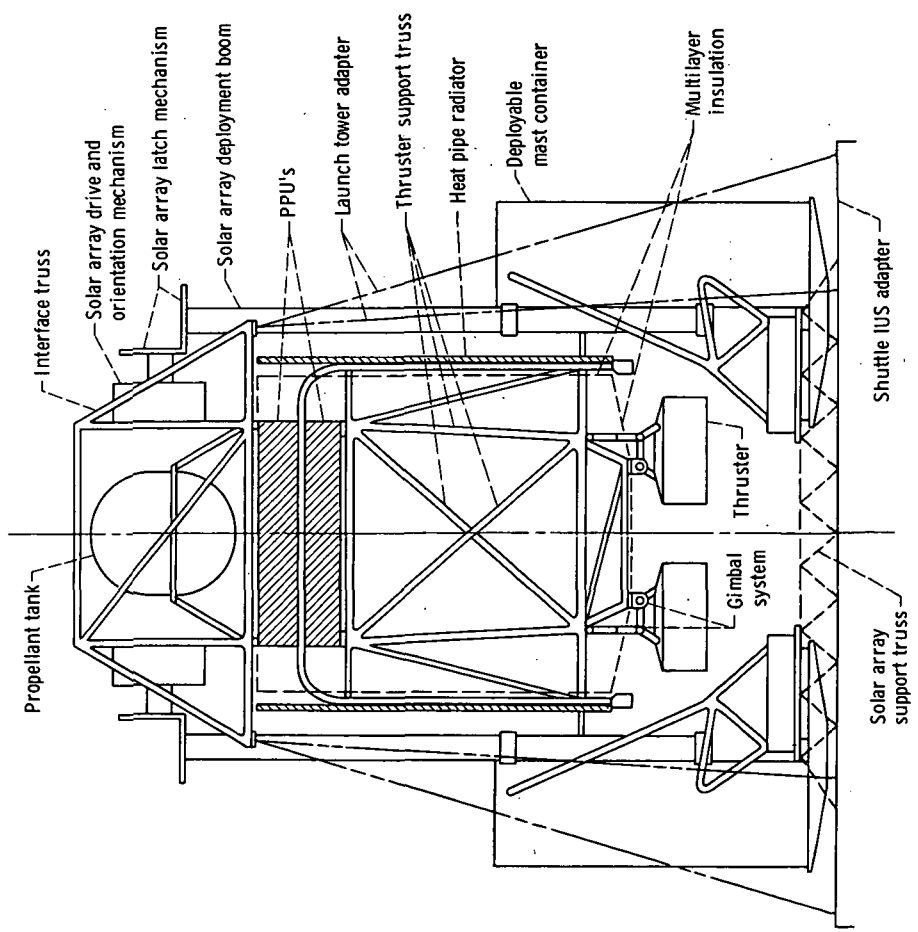

Figure 16. - BIMODULAR SEP/M

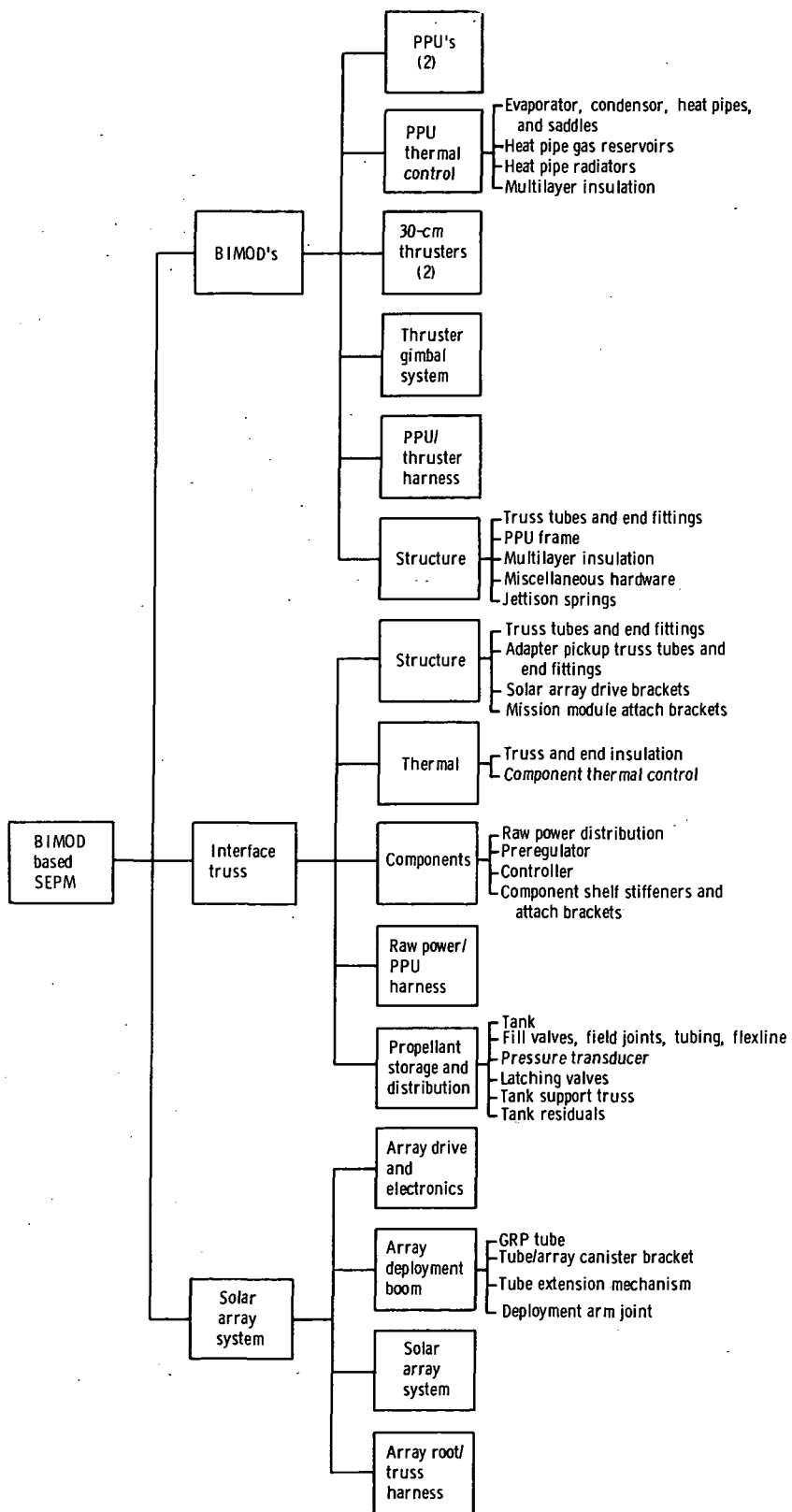
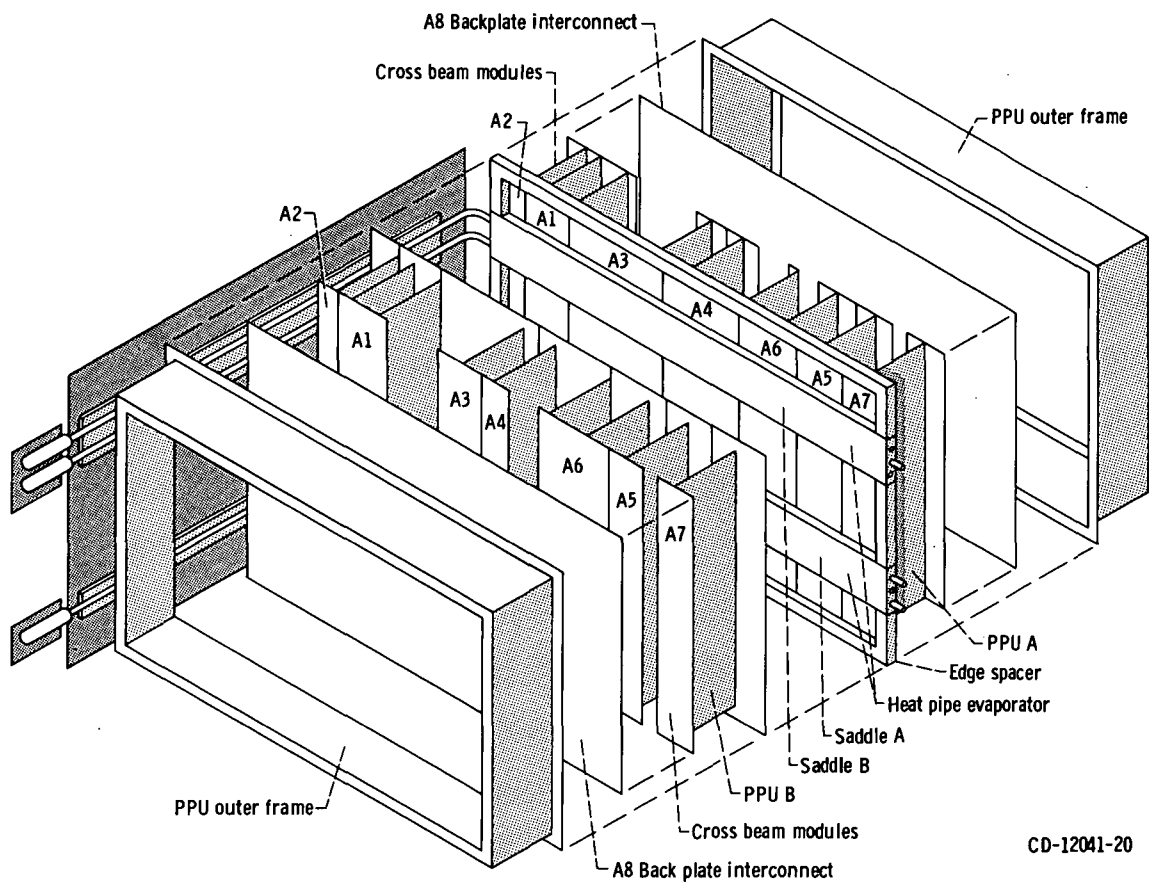

Figure 18. - BIMOD based SEP equipment diagram.



CD-12041-20

Figure 19. - BIMOD assembly. (Near side radiator fin and heat pipe condenser not shown.)



POSTMASTER: If Undeliverable (Section 158  
Postal Manual) Do Not Return

*"The aeronautical and space activities of the United States shall be conducted so as to contribute . . . to the expansion of human knowledge of phenomena in the atmosphere and space. The Administration shall provide for the widest practicable and appropriate dissemination of information concerning its activities and the results thereof."*

—NATIONAL AERONAUTICS AND SPACE ACT OF 1958

## NASA SCIENTIFIC AND TECHNICAL PUBLICATIONS

**TECHNICAL REPORTS:** Scientific and technical information considered important, complete, and a lasting contribution to existing knowledge.

**TECHNICAL NOTES:** Information less broad in scope but nevertheless of importance as a contribution to existing knowledge.

**TECHNICAL MEMORANDUMS:** Information receiving limited distribution because of preliminary data, security classification, or other reasons. Also includes conference proceedings with either limited or unlimited distribution.

**CONTRACTOR REPORTS:** Scientific and technical information generated under a NASA contract or grant and considered an important contribution to existing knowledge.

**TECHNICAL TRANSLATIONS:** Information published in a foreign language considered to merit NASA distribution in English.

**SPECIAL PUBLICATIONS:** Information derived from or of value to NASA activities. Publications include final reports of major projects, monographs, data compilations, handbooks, sourcebooks, and special bibliographies.

**TECHNOLOGY UTILIZATION PUBLICATIONS:** Information on technology used by NASA that may be of particular interest in commercial and other non-aerospace applications. Publications include Tech Briefs, Technology Utilization Reports and Technology Surveys.

Details on the availability of these publications may be obtained from:

SCIENTIFIC AND TECHNICAL INFORMATION OFFICE

NATIONAL AERONAUTICS AND SPACE ADMINISTRATION

Washington, D.C. 20546