

1 # 11-20339 IN

N77-191637

Not on

ADVANCED PROPULSION CONCEPTS STUDY

COMPARATIVE STUDY OF SOLAR ELECTRIC PROPULSION AND LASER ELECTRIC PROPULSION

FINAL REPORT

JUNE 1975

JPL CONTRACT NO. 954085

(NASA CONTRACT NAS7-100)

PREPARED FOR

JET PROPULSION LABORATORY

CALIFORNIA INSTITUTE OF TECHNOLOGY

4800 OAK GROVE DRIVE

PASADENA, CA 91103

**REPRODUCIBLE COPY
(FACILITY CASSETTE COPY)**





ADVANCED PROPULSION CONCEPTS STUDY
COMPARATIVE STUDY OF SOLAR ELECTRIC PROPULSION
AND LASER ELECTRIC PROPULSION

FINAL REPORT

JUNE 1975

Prepared by

Dr. Robert L. Forward
Principal Investigator
Hughes Research Laboratories
3011 Malibu Canyon Road
Malibu, CA 90265

Prepared for

JET PROPULSION LABORATORY
California Institute of Technology
4800 Oak Grove Drive
Pasadena, CA 91103

Under JPL Contract No. 954085
(Subcontract under NASA Contract NAS7-100 Task Order No. RD-156)

HAC Reference No. D3020
HAC Contract No. B608

TABLE OF CONTENTS

	PAGE
ABSTRACT	1
INTRODUCTION	3
LEP SYSTEM OPTIONS	5
LEP SYSTEM CONFIGURATION AND RATIONALE.	9
COMPARISON OF SEP AND LEP.	11
COSTS OF THE LEP SYSTEM.	15
CONCLUSIONS.	16
RECOMMENDATIONS.	17
BIBLIOGRAPHY	18
APPENDIX A — CONCEPT GENERATION MEETING SUMMARY REPORT	21
APPENDIX B — LASER POWER TRANSMISSION IN SPACE	31
APPENDIX C — COHERENT OPTICAL ADAPTIVE TECHNIQUES (COAT).	43
APPENDIX D — RADIATION COLLECTORS FOR SEP AND LEP	49
APPENDIX E — CONVERSION OF LASER LIGHT TO ELECTRICITY	57
APPENDIX F — FREQUENCY CONVERSION OF LASER LIGHT.	61
APPENDIX G — COMPARISON OF SEP AND LEP THERMAL CYCLES	75

ABSTRACT

This is the final report on a 12 person-week study to compare solar electric propulsion (SEP) and laser electric propulsion (LEP). A number of concepts for an LEP system were generated and the critical technology areas of each briefly studied. The LEP system configuration finally chosen for the comparative study consists of a 80 kW visible laser source on earth, transmitting via an 8 m diameter adaptively controlled phased array through the atmosphere to a 4 m diameter synchronous relay mirror that tracks the LEP spacecraft. The spacecraft has an 8 m diameter photovoltaic array matched to the laser wavelength. The mission is a space tug mission from low orbit out to synchronous orbit. The LEP system is compared to a similar SEP system which has been studied extensively by Harney, Lapins, and Molitor. The only significant change in the SEP spacecraft for an LEP mission is the replacement of the two 3.7 m by 33.5 m solar cell arrays with a single 8 m diameter laser photovoltaic array. The solar cell array weight is decreased from 320 kg to 120 kg for an increase in payload of 200 kg and a decrease in specific mass of the power system from 20.5 kg/kW to 7.8 kg/kW. The LEP approach, however, does require the launch and installation of a synchronous mirror and tracking system. The weight of this would be amortized over many LEPTUG missions. Future studies recommended are R&D on optimizing photovoltaic cells for laser light, development of medium power visible laser sources, and R&D on upconversion of high average power IR laser light to the visible.

INTRODUCTION

The work covered by this report is a comparative study of solar electric propulsion (SEP) and laser electric propulsion (LEP). The scope of the work was limited by a number of guidelines to keep the effort within the bounds of reasonably near future technology developments (5 to 10 years), and consistent with the level of effort for the study (12 person-weeks). The words "Laser Electric Propulsion" itself implies many of these guidelines. One guideline is that the power transmitted should be at typical laser wavelengths ($10\ \mu\text{m} \rightarrow 0.5\ \mu\text{m}$). As a practical matter, we limited our considerations to

- o Long IR — $10\ \mu\text{m}$ — CO_2 and Gas Dynamic Lasers
- o Short IR — 3 to $5\ \mu\text{m}$ — Chemical and CO Lasers
- o Visible — 1 to $0.5\ \mu\text{m}$ — Ion, Excimer and Metal Vapor Lasers

Each of these have trade-offs in efficiency, power, atmospheric propagation, free space propagation, efficient optics and efficient conversion to electrical power. These trade-offs were not obvious and laser frequency was left as an open option.

A second guideline implied by the words LEP, is that the laser power must be converted to electrical power before it is used for propulsion. There are many ways that laser power may be used directly for propulsion, but these were to be eliminated from future consideration for this JPL study, as they were being studied elsewhere.

A third guideline implied by LEP is that the propulsion mechanism must use electrical power to provide the thrust. In addition, the purpose of the study was to compare Solar Electric Propulsion (SEP) with LEP. Although there are many possible concepts for electric thrusters (mercury ion, cesium ion, plasma, MHD, etc.), the most developed SEP systems use ion thrusters. To keep the JPL study within bounds, we arbitrarily assumed that mercury bombardment ion thrusters will be used in both the SEP and LEP systems. A typical ion thruster module requires 3 kW of power. The number of modules

depend upon the mission. Near earth missions will use 6 to 20 modules. Longer missions or larger payloads may require 30 to 100 modules. Thus, the amount of electrical power needed in future missions will range from 20 kW to 300 kW. This is a significant amount of power to be obtained from beamed laser energy, but it is not large compared to the total power levels under development on DoD programs.

The restriction to the inherently low thrust-to-weight ion engine propulsion means further that surface-to-earth-orbit missions are not feasible. Thus, the types of missions which could be considered were: orbit changing from near-earth up to synchronous orbit, translunar escape missions, synchronous orbit station-keeping, and interplanetary trajectories.

The basic difference between SEP and LEP can be summarized by two terms: flux intensity and coherency. The solar flux is fixed as a function of distance from the sun and has inverse square dependence. By contrast, laser flux intensity can be increased or decreased at will by adjusting laser power, aperture, wavelength, and refocusing optical relay stations. Laser light is coherent while sunlight is, of course, incoherent. The increased flux intensity potentially achievable with lasers means possible reduced weight of the on-board collector and/or electric converter for the same power delivered to the thrusters. The coherency of laser light may also offer advantages of increased conversion efficiency with specially optimized conversion systems. Better conversion efficiency also means reduced weight for the collector-electric converter. It is well known that for power-limited, low-acceleration propulsion, the specific mass of the power system ($\alpha_0 = \text{kilograms/kilowatt}$) is of major importance. Any advantages that we may hope to gain from LEP over SEP must come in the final analysis from reduced power system specific mass.

The study effort started with a concept generation meeting (brainstorming session) with a selected team of HRL scientists in the fields of lasers, optics, propulsion, and space physics and engineering. The report of that meeting is included as Appendix A. The meeting generated a number of new concepts for LEP components and systems, and a number of LEP system options were uncovered.

LASER ELECTRIC PROPULSION (LEP) SYSTEM OPTIONS

An LEP system consists of four basic subsystems that provide

- o generation
- o transmission
- o collection, and
- o conversion to electricity

of the laser power. Each of these subsystems can have a number of components with different variations, combinations and options. A complete listing is in Appendix A, and a generalized diagram of the various system component options is shown in Fig. 1.

From the several combinations of options, a number of candidate LEP systems were generated. Some examples are:

1. An ion, excimer, or metal vapor ($0.5 \mu\text{m}$) laser source on earth, transmitting via a small COAT phased optical array through the atmosphere to a synchronous relay mirror that tracks the spacecraft. The spacecraft has a photovoltaic array matched to the laser wavelength.
2. A CO_2 ($10.6 \mu\text{m}$) or other IR laser source on earth. The IR laser light is upconverted on the ground to $0.5 \mu\text{m}$ and transmitted via a small COAT phased optical array through the atmosphere to a synchronous relay mirror that tracks the spacecraft. The spacecraft has a photovoltaic array matched to the laser wavelength.
3. A CO_2 ($10.6 \mu\text{m}$) or other IR laser on earth, transmitting via a large, but simple COAT array through the atmosphere to a synchronous relay system that captures the IR beam, upconverts it to $0.5 \mu\text{m}$ and transmits it through small optics to a wavelength matched photovoltaic array on the spacecraft.
4. A CO_2 ($10.6 \mu\text{m}$) or other IR laser on earth, transmitting via a large, but simple COAT array through the atmosphere to a synchronous relay mirror that tracks the spacecraft. The spacecraft collector is a large photon bucket that

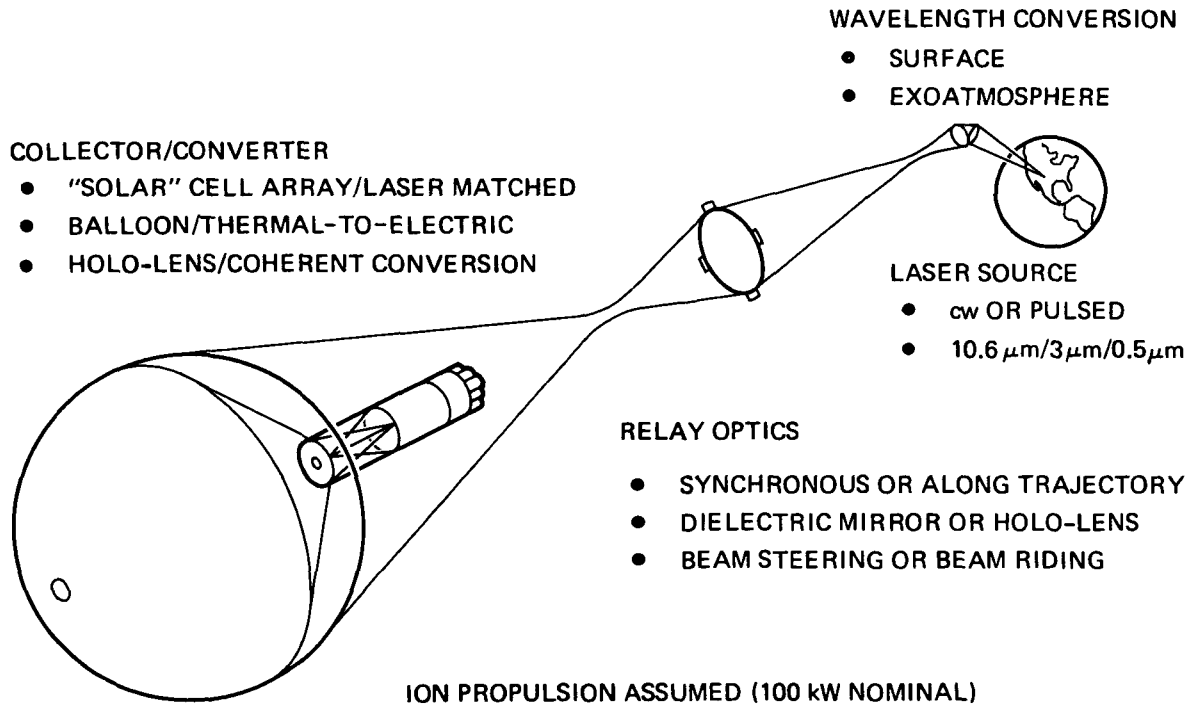

Fig. 1. Laser electric propulsion generalized system component options.



focuses the IR energy onto an absorber that provides a high temperature heat source for a thermodynamic engine coupled to an electric generator.

5. A CO₂ or other IR laser on earth, transmitting via a large, but simple COAT array through the atmosphere to a synchronous relay mirror that tracks the spacecraft. The spacecraft collector is a high quality mirror or hologram lens that collects and recollimates the IR laser beam, then downconverts it to the microwave region. The microwave power is then rectified by a large array of microwave diodes to provide electrical power.
6. A highly efficient CO or other IR laser in orbit around earth, transmitting through large hologram optics, with the IR beam periodically picked up by a beam riding hologram lens dropped off by the outgoing spacecraft. The IR beam is captured by a balloon structure with a reflective multilayer coating that directs it to an absorbing body. The electrical power for the ion thrusters is obtained from thermionic diodes operating off the heat source.

Other minor perturbations of these general LEP system concepts are also obvious candidates that are just as viable as the specific ones outlined above.

A number of the above LEP system options have critical technological aspects that determine their viability. We carried out technical analyses of a number of these critical aspects. The results of these analyses are in appendices to this report.

In Appendix B, we studied the propagation of laser light and determined the power flux that could be expected as a function of wavelength, distance, size of optics, etc. In Appendix B, we also estimated the present state of the art of laser power sources for LEP systems and projected the capability of these LEP power sources as a function of time. The data generated in Appendix B then determined the regimes where the level of capability of an LEP system could exceed that of an SEP system.

Since many of the LEP system options involve the transmission of laser light through the atmosphere, they will likely involve the use of coherent optical adaptive techniques (COAT) in the transmitting array to achieve high quality beams and high precision pointing and tracking. COAT systems are undergoing a rapid development effort as part of the DoD laser programs. For this JPL study we have assumed that the COAT techniques will be available when they are needed for LEP. In Appendix C we summarize the COAT concepts, and how they would be used for laser power transmission to a satellite.

In Appendix D we study one of the critical areas of difference between an SEP system and an LEP system – the light collector. In Appendix D we estimate the collector area improvement obtained by going from solar light to laser light, and the effect of this improvement on various important mission parameters, such as trip time and payload ratio.

The many LEP system options all require the conversion of laser light into electricity. In Appendix E, we summarize the various methods and technologies for accomplishing this.

Since some of the LEP system options require the conversion of laser light to different frequencies, we also studied the feasibility of obtaining such frequency conversion in an efficient manner. This study is presented as Appendix F.

Both SEP and LEP systems could use a thermal cycle for converting radiation to electricity. In Appendix G we look at this option and find that it has no significant advantage over an efficient photovoltaic system.

After these initial technical studies, we then chose an LEP system concept and mission, and compared it to an SEP system concept for the same mission.

LEP SYSTEM CONFIGURATION AND RATIONALE

The LEP system configuration chosen for the study consists of a visible ($0.5 \mu\text{m}$) medium power (80 kW) ion, metal vapor, excimer, or upconverted IR laser source on earth, transmitting via an 8 m diameter COAT phased optical array through the atmosphere to a 4 m diameter synchronous relay mirror that tracks the spacecraft. The spacecraft has an 8 m diameter photovoltaic array matched to the laser wavelength. The mission is a space tug mission from low orbit out to synchronous orbit.

A major assumption that we made in our choice of the LEP system for the LEP-SEP comparison is that the laser should be based on the earth's surface. The relatively poor electric power-to-light conversion efficiency of even the best anticipated lasers, combined with the remaining multiplicative inefficiencies in the total link, restricts the laser to earth surface operation for the foreseeable future. The requirement for electric propulsion to have nearly continuous power input means either many ground based laser stations or a single ground laser beaming to a synchronous orbit relay satellite. The relay could be simply an attitude stabilized mirror which would track the ion-engine propelled spacecraft. For economic reasons the single ground station is much to be preferred.

Assuming that the laser power would come from earth's surface, we further assume that laser arrays employing coherent optical adaptive techniques (COAT) would be used to overcome most of the atmospheric degradation and to track the synchronous relay. Diffraction limited divergence angles through the earth's atmosphere, as well as accurate pointing and tracking, should be achievable with COAT systems presently under DoD and NASA development.

Our choice of LEP system was also affected by the assumption that NASA would not be in a position to fund any significant development effort on an LEP subsystem, especially if it involved an orbital flight test to prove feasibility. Since light-to-thermal-to-electric power

systems have not been developed and flight tested, whereas a great deal is known about photovoltaic cells, it was felt that the thermal converter cycles such as were mentioned in LEP options 4 and 6 were not suitable for consideration in an LEP system at this time. For the same reasons (although they are technically attractive), the concept of upconverting or downconverting the laser light in space, either at the synchronous relay or on the spacecraft as mentioned in options 3 and 5, were also felt to be premature, although worthy of continued NASA R&D effort.

The LEP system configuration chosen is a combination of options 1 and 2. The major area of uncertainty in the LEP system is the source of the visible laser light. At present, the highest average power level quoted in the open literature is around a kilowatt for an argon ion laser. Copper vapor and excimer lasers have generated a significant number of watts, and show considerable promise for visible or uv laser sources, but still have a long way to go before they will reach the multikilowatt level. An alternative for the visible laser light source is the upconversion of IR laser light to the visible region. The average and peak power levels obtainable in the IR from a number of different types of lasers are more than adequate as a prime laser power source for an upconverter. But, the demonstration of efficient conversion into the blue end of the visible spectrum at high average power levels has yet to be demonstrated. This is a prime candidate for future NASA R&D support.

Despite the uncertainty in the source of the 80 kW of visible laser power required for the candidate LEP system, we feel that with the present level of DoD support for laser research, that it was reasonable to assume that this level of laser power would be attained in the future, and that the proposed LEP system was the most viable of the many options discussed.

COMPARISON OF SEP AND LEP

For the comparison study between LEP and SEP we selected a SEP tug (SEPTUG) vehicle and mission proposed by the Space Systems Division of Hughes Aircraft Company [Harney 1972]. The characteristics of the SEPTUG and its mission are given in summary in Table 1. The purpose of the SEPTUG is to deliver payloads to and from synchronous orbit, perhaps the most important and demanding mission of near earth operations. The payloads are put into low earth orbit initially by the space shuttle. The reusability of the SEPTUG over a period of several years before refurbishment is its major advantage. For economy, the SEPTUG must retrieve a synchronous orbit satellite for maintenance, etc. each time it injects a new geostationary payload.

The critical element for comparison with a corresponding LEP vehicle (LEPTUG) is the SEPTUG solar array. The roll-up solar array comprises about 75% of the weight of the (20 kW) SEPTUG propulsion-power system, which has an overall α of 20.5 kg/kW. If we postulate 25% conversion efficiency wavelength optimized cells for the LEP array, we can achieve at least a 50% reduction from the area of the SEP array. For similar areal weight densities this means a reduction of power subsystem specific mass to 63% of its SEP value for laser flux equivalent to solar flux. It must be assumed that solar flux will augment the power produced by the wavelength optimized LEP array, leading to further specific mass reductions. The fundamental limitation on further reducing the LEPTUG array area is the temperature-efficiency requirement [Arno 1972] to keep the incident flux at some moderate value between 1.0 and 10 times the 1 A.U. solar flux of about 1.4 kW/m². An LEP array 8 m in diameter (50 m²) intercepting an 80 kW laser beam would have an incident power flux of about 1.6 kW/m² and thus would not be temperature limited. With this size array, the specific mass of the LEP system can be reduced to 7.8 kg/kW or 38% of the SEP value (see Table 2 and Fig. 2).

Table 1. SEPTUG Characteristics [Harney 1972]

<u>Mission:</u>	Deliver payloads to and from synchronous orbit, from and to low altitude earth orbits - reusable
<u>Major Trajectory Constraint:</u>	50% or greater degradation in solar cell array power possible without fast assist by chemical stage into elliptical transfer orbit, minimizing van Allen belt transit.
<u>Transfer Orbit:</u>	<ol style="list-style-type: none"> 1. Initial 300 n.mi. circular shuttle orbit 2. Transfer ellipse by chemical kick stage (ISP = 450 sec) 45,000 lb propellant (300 n.mi. x 19,300 n.mi.) 3. Synchronous orbit
<u>Time Before Refurbishing:</u>	2 years
<u>ISP:</u>	3500 sec
<u>Thrusters:</u>	Twelve 30 cm mercury bombardment ion thrusters
<u>Solar Array:</u>	Two flexible roll-up panels (each 3.7 m x 33.5 m) estimated 320 kg
<u>Array Power:</u>	20 kW - only ~10% degradation with chemical kick stage ~10% efficiency
<u>Payload:</u>	<p>Seven two-way trips with 2000 lb payloads, 90 day round trip time</p> <p style="text-align: center;">OR</p> <p>Four two-way trips with 6200 lb payloads, 180 day round trip time</p>
<u>Array Temperature Limits:</u>	90° to 438°K
<u>Total Specific Mass, α of Propulsion System:</u>	20.5 kg/kW
<u>Power System Specific Mass, α_o:</u>	15.7 kg/kW $\frac{\alpha_o}{\alpha} \sim 75\%$

Table 2. LEPTUG Characteristics

Same Mission, Thrusters, etc. as SEPTUG but Different Power System:	
<u>Array Power:</u>	20 kW
<u>Array Conversion Efficiency for 0.5 μm Laser Light</u>	$\eta_{LA} = 25\%$
<u>Laser Beam Power Required:</u>	80 kW
<u>Maximum Beaming Distance with Synchronous Orbit Relay and Single Ground Laser:</u>	$\sim 84,000$ km
<u>Collector Array:</u>	8 m dia., 120 kg
<u>Synchronous Relay Mirror:</u>	4 m dia.
<u>Laser Array:</u>	8 m dia.
<u>Estimated Specific Mass, α, of Propulsion System:</u>	7.8 kg/kW

The maximum beaming distance in such a mission using one synchronous relay is about twice the altitude of synchronous orbit 84,000 km. Reference to Fig. 5 in Appendix B for $\lambda = 0.5 \mu\text{m}$ indicates that to efficiently illuminate an 8 m diameter collector at twice synchronous distance would require a COAT laser array of 8m aperture. This should be attainable with currently projected DoD laser technology.

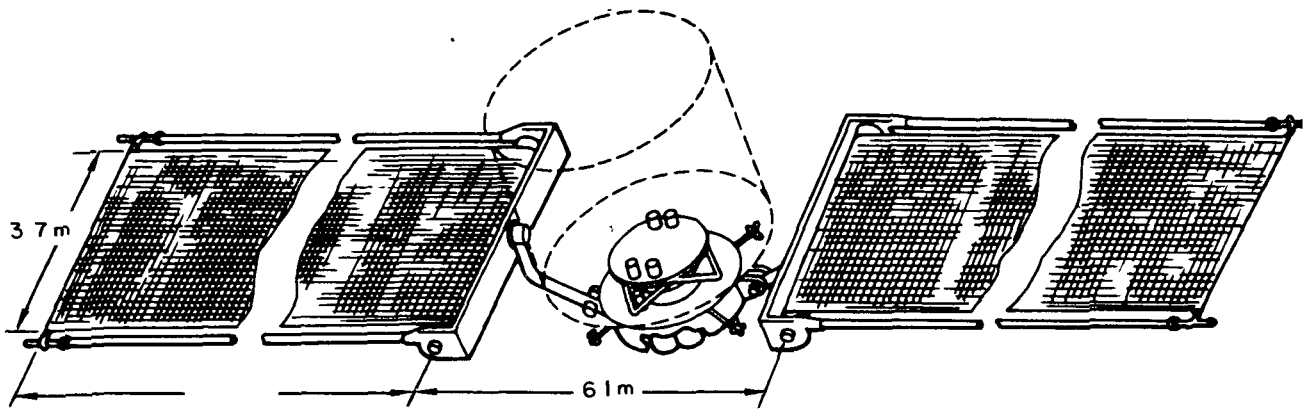

Fig. 2(a). Artist's Concept of SEPTUG [Harney 1972]

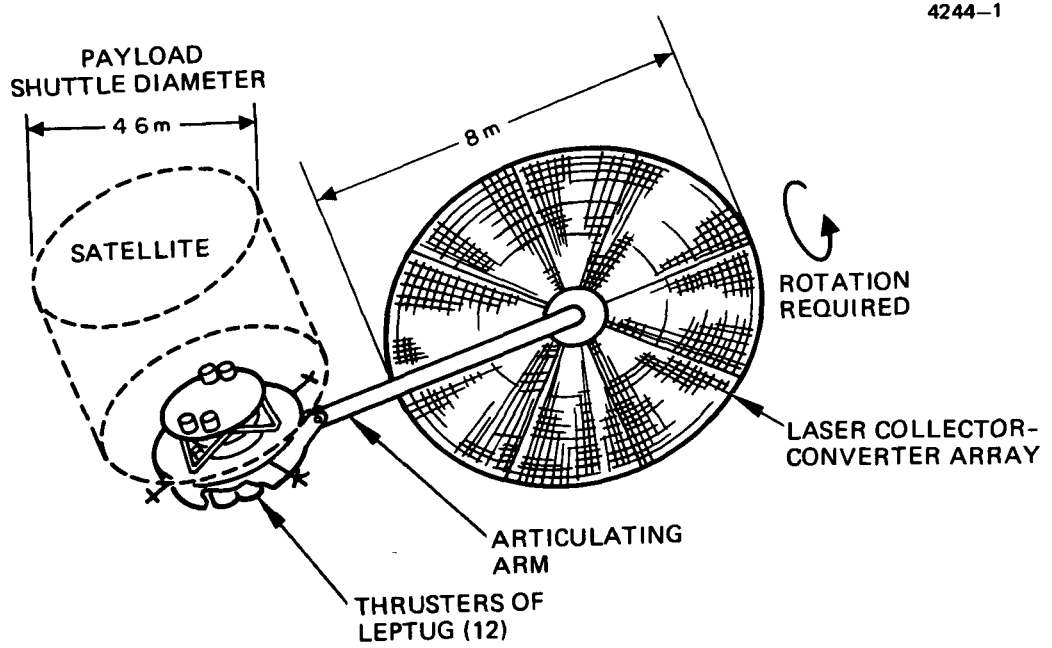

Fig. 2(b). Artist's Concept of LEPTUG

COSTS OF THE LEP SYSTEM

A specific task in the statement of work for the contract is to project the costs for laser electric propulsion. Because of the contract level-of-effort and the uncertainties that still exist in the candidate LEP system, especially the laser source, we can only roughly estimate these costs based on rough comparisons with similar systems. Most of the estimated costs are significantly higher than might be expected because of the requirement for long operational life. Our present estimated costs for the various subsystems are:

Laser Power Source	\$10M
COAT Transmitter	\$20M
Synchronous Relay Mirror	\$20M
LEPTUG (Differential over cost of SEPTUG)	\$ 2M

CONCLUSIONS

We have identified a potentially useful LEP system configuration. It consists of a visible ($0.5 \mu\text{m}$) medium power (80 kW) laser source on earth, transmitting via an 8 m diameter COAT array through the atmosphere to a 4 m diameter synchronous relay mirror that tracks the spacecraft. The spacecraft has an 8 m diameter photovoltaic array matched to the laser wavelength that provides electrical power to ion thrusters. The mission is a space tug mission from low orbit out to synchronous orbit.

The SEP space tug mission has been studied extensively [Harney 1972]. The only significant change in the SEP spacecraft for an LEP mission is the replacement of the two 3.7 m by 33.5m (123 m^2) solar cell arrays with an 8 m diameter (50 m^2) laser photovoltaic array. The solar cell array weight is decreased from 320 kg to 120 kg for an increase in payload of 200 kg and a decrease in specific mass of the power system from 20.5 kg/kW to 7.8 kg/kW. The LEP approach, however, does require the launch and installation of the synchronous mirror and tracking system. The weight of this would be amortized over many LEPTUG missions.

RECOMMENDATIONS

In order to further LEP technology we recommend the following future work.

- Monitor medium power 50-500 kW visible laser and optics developments in DoD and initiate R&D on those aspects not covered by DoD activities.
- Conduct R&D on optimization of photovoltaic arrays for visible laser frequencies (choice of base material, design of junctions, antireflection coatings, etc.).
- Conduct R&D on upconversion of high average power IR laser light to the visible.

Other recommended work of lower priority would be to:

- Conduct R&D on downconversion of IR laser frequencies to millimeter wave and microwave frequencies.
- Conduct R&D on optimization of power rectifiers at short microwave frequencies for handling of high average power levels.

BIBLIOGRAPHY

Alfvén, Hannes

"Spacecraft Propulsion: New Methods," in Science, Vol. 176, No. 4031, April 14, 1972, 167-68.

Arno, R. D.

MacKay, J. S.

Nishioka, K.

"Applications Analysis of High Energy Lasers," NASA TM X-62142, March, 1972.

Bloomer, J. H.

"The Alpha Centauri Probe," in Proc. 17th Int. Astronautical Congress (Propulsion and Re-Entry), Madrid, 1966, Gordon and Breach, Inc., New York, 1967, 225-232.

Chapman, P. K.

"Laser Propulsion to Relativistic Velocities for Interstellar Flight," Proc. 24th I. A. F. Congress, Baku, U. S. S. R., Oct. 7-13, 1973.

Forward, Robert L.

"Ground Based Lasers for Propulsion in Space," Hughes Research Laboratories internal paper, May 19, 1961.

Hansen, C. Frederick

Lee, George

"Laser Power Stations in Orbit," Astronautics and Aeronautics, Vol. 10, No. 7, July, 1972, 40-54.

Hertzberg, A.

Johnston, E. W. and Ahlstrom, H. G.

"Photon Generators and Engines for Laser Power Transmission," AIAA Paper No. 71-106, January 25-27, 1971.

Kantrowitz, Arthur

"Propulsion to Orbit by Ground-Based Lasers," Astronautics and Aeronautics, Vol. 10, No. 5, May, 1972, 74-76.

Marx, G.

"Interstellar Vehicle Propelled by Terrestrial Laser Beam," Nature, Vol. 211, July 2, 1966, 22-23.

Minovitch, Michael A.

"Reactorless Nuclear Propulsion - The Laser Rocket," AIAA Paper 72-1095, December, 1972.

Moeckel, W. E.

"Propulsion by Impinging Laser Beams," Journal of Spacecraft and Rockets, Vol. 9, No. 12, December, 1972, 942-944.

McLafferty, George H.

"Laser Energy Absorption in the Exhaust Nozzle of a Laser-Powered Rocket," United Aircraft Research Laboratories Report UAR-G256, January 15, 1969.

Norem, Philip C.

"Interstellar Travel, A Round Trip Propulsion System with Relativistic Velocity Capabilities," American Astronautical Society Paper No. 69-388, June, 1969.

Pirri, A. N.

"Laser Propulsion," AIAA Paper 72-719, June, 1972.

Pirri, A. N.

Monsler, M. J.

Nebolsine, P. E.

"Propulsion by Absorption of Laser Radiation," AIAA Paper 73-624, July, 1973.

Redding, J. L.

"Interstellar Vehicle Propelled by Terrestrial Laser Beam," Nature, February 11, 1967, 588-589.

Rom, Frank E.

Putre, Henry A.

"Laser Propulsion," NASA TM X-2510, April, 1972.

Willinski, Martin I.

"Beamed Electromagnetic Power as a Propulsion Energy Source," American Rocket Society Journal, August, 1958, 602-603.

Moeckel, W. E.

"Comparison of Advanced Propulsion Concepts for Deep Space Exploration," J. Spacecraft and Rockets, Vol. 9, No. 12, December, 1972, 863.

Nored, Donald L.

"Application of High Power Lasers to Space Power and Propulsion," presented at 2nd NASA Conf. on Laser Energy Conversion, Ames Research Center, Jan 27-28, 1975.

Ehrlicke, K. A.

"Solar Propulsion," Section 21.3 in Handbook of Astronautical Engineering, H. H. Koelle, editor, McGraw-Hill Book Co., Inc., 1961.

Fichtner, H.

"Electrical Systems and Power Sources," Section 15.1 in Handbook of Astronautical Engineering, H. H. Koelle, editor, McGraw-Hill Book Co., Inc., 1961.

Billman, Kenneth W. (editor)

"Laser-Energy Conversion Symposium," NASA TM X-62269,
September, 1973.

Harney, E. D.

Lapins, U. E.

Molitor, J. H.

"Geocentric Solar Electric Propulsion Vehicle Design," AIAA
Paper 72-1126, presented at AIAA/SAE 8th Joint Propulsion Specialist
Conf., New Orleans, Louisiana, (29 Nov - 1 Dec, 1972).

Reilly, James P.

"High Power Electric Discharge Lasers (EDL's)," Astronautics and
Aeronautics, March, 1975.

Warren, Walter R.

"Chemical Lasers," Astronautics and Aeronautics, April, 1975.

Ewan, J.

Kamath, G. S.

Knechtli, R. C.

"Large Area GaAlAs/GaAs Solar Cell Development," Proc. IEEE/AIAA
Photovoltaic Spec. Conf., Phoenix, Arizona, (1975).

She, Joe

Billman, K.

"Third Harmonic and Sum Frequency Generation Pumped by CO and CO₂
Lasers," 2nd NASA Conf. on Laser Energy Conversion, Moffett Field,
Calif., (27-28 Jan. 1975).

Papailiou, D. D. (Editor)

"Frontiers in Propulsion Research," JPL TM 33-722, Pasadena, Ca.,
(15 March 1975).

APPENDIX A
CONCEPT GENERATION MEETING
SUMMARY REPORT

Prepared by
Dr. Robert L. Forward

MEETING ORGANIZATION

A concept generation session was held 22 November 1974 to generate concepts for Laser Electric Propulsion (LEP) systems and components, especially concepts for conversion of laser power to electrical power. Attending were:

Dr. A. N. Chester, Manager, Lasers Department
Dr. I. J. D'Haenens, SMTS, IR Detectors
Dr. J. Hyman, Head, Plasma Research Section
Dr. G. M. Janney, Head, Chemical Lasers Section
Mr. S. A. Kokorowski, MTS, Systems Analysis
Dr. M. A. Lutz, Head, Laser Power Conditioning Section
Dr. A. J. Palmer, SMTS, Lasers
Dr. C. J. Swigert, Project Scientist, COAT
Dr. R. L. Forward, Manager, Exploratory Studies Department

MEETING GUIDELINES

Prior to the concept generation meeting, we generated some initial guidelines to keep the discussion under control. The name "Laser Electric Propulsion" itself implies many of these guidelines. One guideline is that the power transmitted should be at typical laser wavelengths ($10 \mu\text{m} \rightarrow 0.5 \mu\text{m}$). As a practical matter, we limited our considerations to

- Long IR - $10 \mu\text{m}$ - CO_2 and Gas Dynamic Lasers
- Short IR - $3\text{-}5 \mu\text{m}$ - Chemical and CO Lasers
- Visible - $1\text{-}0.5 \mu\text{m}$ - Ion and Metal Vapor Lasers

Each of these have trade-offs in efficiency, power, atmospheric propagation, free space propagation, efficient optics and efficient conversion to electrical power. These trade-offs are not obvious and laser frequency was left as an open option.

A second guideline implied by the words LEP, is that the laser power must be converted to electrical power before it is used for propulsion. There are many ways that laser power may be used directly for propulsion (and some were brought up during the concept generation session), but these were to be eliminated from future consideration for the JPL study, as they are being studied elsewhere.

A third guideline implied by LEP is that the propulsion mechanism must use electrical power to provide the thrust. In addition, the purpose of the study was to compare Solar Electric Propulsion (SEP) with LEP. Although there are many possible concepts for electric thrusters (mercury ion, cesium ion, plasma, MHD, etc.), the most developed SEP systems use ion thrusters. To keep the JPL study within bounds, we have arbitrarily assumed that mercury bombardment ion thrusters will be used in both the SEP and LEP systems. A typical ion thruster module requires 3 kW of power. The number of modules depend upon the mission (typically 6 to Venus, 15 to Mars). Longer missions or larger payloads may require 30 to 100 modules. Thus the amount of electrical power needed in future missions will range from 20 kW to 300 kW. We have chosen a nominal desired thruster power of 100 kW. This is a significant amount of power to be obtained from beamed laser energy, but it is not large compared to the total power levels under development by the DoD.

The concept generation meeting was structured to the extent that we attempted to spend equal amounts of time on the four basic subsystems of the total LEP system. The following is an organized listing of the various ideas that were generated as they related to the various subsystems.

LEP SYSTEM COMPONENTS

An LEP system consists of four basic subsystems that provide:

- I. Generation,
- II. Transmission,
- III. Collection, and
- IV. Conversion

of the laser power. Each of these subsystems can have a number of components (some optional). A partial listing follows:

- I. Generation
 - A. Site
 - B. Prime Power Source
 - C. Laser Type(s)
- II. Transmission
 - A. Optics
 - B. Propagation
 - C. Relay(s) (optional)
 - D. Frequency Conversion (optional)
- III. Collection
 - A. Optics
- IV. Conversion
 - A. Frequency Conversion (optional)
 - B. Laser-Electric Conversion Mechanism

Each of these component elements have variations, combinations and options — a partial listing follows:

- I. Generation
 - A. Site
 1. Earth
 - a. anywhere
 - b. poles (continuous viewing)
 - c. high mountains (less atmosphere)
 - d. ships (avoid cloud cover)

2. Earth Orbit
 - a. low
 - b. synchronous
 3. Moon
 - a. surface
 - b. orbit
 4. Solar Orbit
 - a. earth orbit (Trojan point)
 - b. other planetary orbit
 - c. inside Mercury
- B. Prime Power Source
1. Solar
 - a. collector/converter array
 - b. solar pumped laser
 - c. lase solar plasma with mirrors in orbit
 2. Chemical
 3. Electrical
 4. Chemical/Electrical
 5. Nuclear
- C. Laser Type(s)
1. Mode of Operation
 - a. cw (efficient)
 - b. pulsed (transmit through atmosphere better)
 2. Optical Design
 - a. resonator/amplifier
 - b. high power resonator
 - c. long laser (one laser end mirror in orbit or on spacecraft)

II. Transmission

A. Optics

1. Monolithic
2. Phased Array
 - a. open
 - b. filled
3. Coherent Adaptive Phased Array
 - a. multidither
 - b. conjugate phase
 - c. reference (pilot) wave
 - d. (many other system options)

B. Propagation

1. Atmosphere Absorbtion vs. λ
2. Weather
3. Site

C. Relay(s)

1. Position
 - a. synchronous
 - b. low orbit
 - c. along trajectory
2. Mode of Operation
 - a. capture, reform and redirect beam
 - b. capture, wavelength convert and re-direct beam'
 - c. active
 - laser powered thrusters
 - solar powered thrusters
 - d. passive beam riders (use laser light pressure differences to maintain position and orientation)

D. Frequency Conversion

1. Convert at source (from optimum generation frequency to optimum atmospheric propagation frequency)
2. Convert during transmission (from optimum atmospheric propagation frequency to optimum free space frequency)

III. Collection

A. Optics

1. Hologram Optics
2. Multilayer Dielectric Mirrors (99.95%)
3. Balloon Structures (hologram corrected)
4. "Solar" Cell Array
5. Black Heat Sink (with or without auxiliary optics)
6. Low Optical Quality "Photon Bucket"

IV. Conversion

A. Frequency Conversion

1. Upconversion to UV (better photon efficiency in photodetectors)
2. Down conversion to mm waves (better conversion efficiency with mm wave diodes)

B. Laser-Electric Conversion Mechanism

1. Photodetectors
2. Thermopile
3. Thermionic Converters
4. Laser - Plasma - MHD
5. Laser - Plasma - Optical - Solar Cells
6. Laser - Heat - Any Thermodynamic Cycle
7. IR Diodes (?)
8. Optical Engines
9. Coherent parametric down conversion to power frequencies (10^{14} Hz \rightarrow 1000 Hz)

NOVEL CONCEPTS

The novel system concepts that were generated as a result of the concept generation meeting are:

- Use of large, lightweight thin plastic film hologram optics.
- Use of balloon structures with multilayer dielectric or hologram lens optical surfaces to obtain desired optical performance from spherical balloon shape.
- Use of active and passive relay optics in transmission system.
- Use of frequency conversion at various stages in transmission system.
- Lasing solar plasma with mirrors in orbit (actually disclosed prior to contract by Hughes employee).
- Use of long laser concept (one end reflector on spacecraft, other on laser) for automatic system alignment.
- Use of Coherent Optical Phased Array (COAT) techniques.

Many of these concepts will probably be used in the candidate LEP system for the comparative study.

CANDIDATE LEP SYSTEMS

There are a large variety of LEP systems that can be generated from the previous listings of system components. Some illustrative examples are:

- A cw metal vapor ($0.5 \mu\text{m}$) laser source on earth, transmitting via a small COAT phased optical array through the atmosphere to a synchronous relay

mirror that tracks the spacecraft. The spacecraft has a photovoltaic array matched to the laser wavelength.

- A CO₂ (10.6 μm) laser on earth, transmitting via a large, but simple COAT array through the atmosphere to a synchronous relay system that captures the IR beam, upconverts it to the UV and transmits it through small optics to a photovoltaic array on the spacecraft.
- A highly efficient CO laser in orbit around earth transmitting through large hologram optics, with the IR beam periodically picked up by a beam riding hologram lens dropped off by the outgoing spacecraft. The IR beam is captured by a balloon structure with a 99.95% reflective multilayer coating that directs it to an absorbing body. The electrical power for the ion thrusters is obtained from thermionic diodes operating off the heat source.

The actual candidate LEP system to be used in the comparative study will probably be close to one of these examples.

APPENDIX B

LASER POWER
TRANSMISSION
IN SPACE

by

Dr. Eugene F. Mallove
Aerospace Consultant

and

Dr. Robert L. Forward
Senior Scientist,
Hughes Research Labs

INTRODUCTION

In any comparison of SEP and LEP, an important parameter for consideration is the ratio of the laser light flux to the solar flux for the specific system design and mission. In general, unless the laser light flux at the spacecraft exceeds the solar light flux, there will be little, if any, advantage to an LEP system. In this study, we carry out a parametric examination of the many variables in the various systems to determine those operating regimes where an LEP system may have an advantage over an SEP system.

LASER FLUX LEVELS IN SPACE

For this study we will assume that in an LEP system the laser light is focused on a circular collector which exactly matches the beam diameter, so negligible power is lost due to an over-expanded beam. We will also assume that the illumination is uniform over the collector area. All references to the laser transmitter diameter, d , are to be interpreted as the equivalent diameter of the transmitting COAT array employed.

The diffraction limited full divergence angle of a gaussian laser beam is often quoted in the literature as

$$\theta = \frac{1.22\lambda}{d} \quad , \quad (1)$$

where λ is laser wavelength and d is laser transmitter diameter. The limit which is readily achievable in practice is usually considered to be (assuming the use of COAT when necessary)

$$\frac{D}{R} = \theta = \frac{2\lambda}{d} \quad . \quad (2)$$

This divergence capability will be assumed throughout this analysis. Under the above conditions, the ratio of flux from an earth-based laser to the solar flux is readily shown to be,

$$\frac{\phi_L}{\phi_S} = (1.1 \times 10^{-11}) \left(\frac{P_L d^2}{\lambda^2} \right) \left(\frac{1}{R^2} \right) \quad , \quad (3)$$

for

$$R \leq 10^{-2} \text{ A.U.}$$

where

- ϕ_L = laser light flux intensity
- ϕ_S = solar flux intensity 1.0 A.U. from the sun
- P_L = total power in laser beam (kilowatts)
- d = laser diameter (meters)
- λ = laser wavelength (micrometers)
- R = distance from earth-based laser (astronomical units (A.U.))

The parameter $P_D = P_L d^2 / \lambda^2$ or the deliverable laser power/range capability of the laser transmitter system, characterizes the state of the available laser technology in a very concise manner. (The unusual units of [kilowatts · meter² / (μm)²] were deliberately selected for rapid visualization of the order of magnitude of P_D .) Table B-1 summarizes our estimates of the present and future capabilities for laser power systems. Figure B-1 is a plot of ϕ_L / ϕ_S versus distance, R , from the laser for a variety of P_D parameters. Distances to synchronous orbit and lunar orbit are indicated for convenience.

Table B-1. Deliverable Laser Power/Range Capability (P_D)

Laser Type	Wavelength, λ , μm	Present			5-10 Year Extrapolation		
		Laser Power, P_L , kW	Optics Diameter, d , m	P_D , $\frac{\text{kW-m}^2}{(\mu\text{m})^2}$	P_L , kW	COAT Array Diameter, d , m	P_D , $\frac{\text{kW-m}^2}{(\mu\text{m})^2}$
CO ₂	10.6	200	2	7	5000	30	4×10^4
DF	3.8	50	2	14	1000	20	1.4×10^4
Ion, Metal Vapor, Excimer or Upconverted IR	0.5	1	1	4	100	10	4×10^4

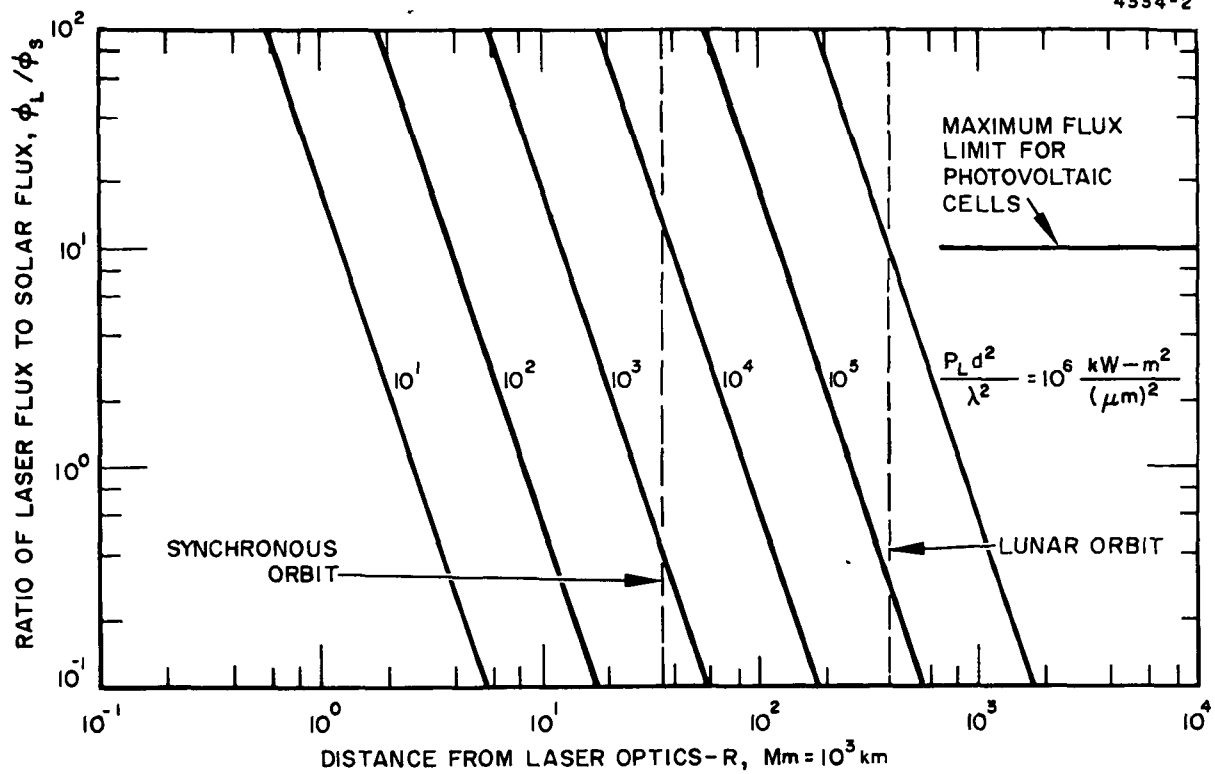

Fig. B-1. Deliverable laser power/range capability.

Figure B-1 is appropriate for near-earth applications of LEP. If interplanetary flights are contemplated, then the inverse square solar flux dependence on distance from the sun must be incorporated in the expression for ϕ_L/ϕ_S . For simplicity, we examine the problem of beaming laser power from earth to a spacecraft in circular orbit about the sun. For a heliocentric orbit of radius, R_S (astronomical units), the minimum distance to earth is simply (R_S-1) at conjunction of earth and spacecraft. The maximum distance between earth and spacecraft is (R_S+1) astronomical units. So we have,

$$\left. \frac{\phi_L}{\phi_S} \right|_{\max} = (1.1 \times 10^{-11}) \left(\frac{P_L d^2}{\lambda^2} \right) \left[\frac{R_S^2}{(R_S - 1)^2} \right] \quad (4)$$

and

$$\left. \frac{\phi_L}{\phi_S} \right|_{\min} = (1.1 \times 10^{-11}) \left(\frac{P_L d^2}{\lambda^2} \right) \left[\frac{R_S^2}{(R_S + 1)^2} \right] \quad (5)$$

A projection of laser technology 5 to 10 years hence (see Table B-1) indicates $P_L d^2/\lambda^2$ on the order of $10^4 - 10^5$. This implies that the minimum and maximum radius ratio functions need to be $\sim 10^6$ to get the laser flux greater than the solar flux. The radius ratio functions for R_S as close to 1.0 as 0.95 and 1.05 are less than 10^3 . This leads to the conclusion that LEP will be useful only in the near-earth-out-to-lunar-orbit region for the foreseeable future. The only development which could hope to alter this picture would be a train of optical relays which a spacecraft might eject along its

trajectory. The relays would refocus the laser beam to prevent divergence attenuation of the beam over long distances.

TRANSMITTER AND COLLECTOR DIAMETERS

A set of useful parametric parameters for this study are the relations between the transmitter and collector diameters, the range between the transmitter and collector, and the laser wavelength that arise under the assumption that we desire the collector to be large enough to collect the entire laser beam from the transmitter.

Without relays, the required radiation collector diameter, D , on the spacecraft is independent of the laser beam power and depends only on range R , the laser wavelength λ and laser diameter d .

$$D = \frac{2\lambda R}{d} \quad (6)$$

Figures B-2, B-3, and B-4 show minimum collector diameter D required for various earth-spacecraft ranges with laser aperture as the parameter. The figures are for $\lambda = 10, 3, \text{ and } 0.5 \mu\text{m}$ respectively.

CONCLUSIONS

An examination of the figures in the two previous sections show some operational regimes where an LEP system might outperform an SEP system. For operation from low orbit out to synchronous orbit, the diameters required for the transmitters and collectors optics are between 1 and 10 meters and the deliverable laser power/range capability ($P_D = P_L d^2 / \lambda^2$) required to exceed the solar flux by a factor of 10 is within the projected state of the art.

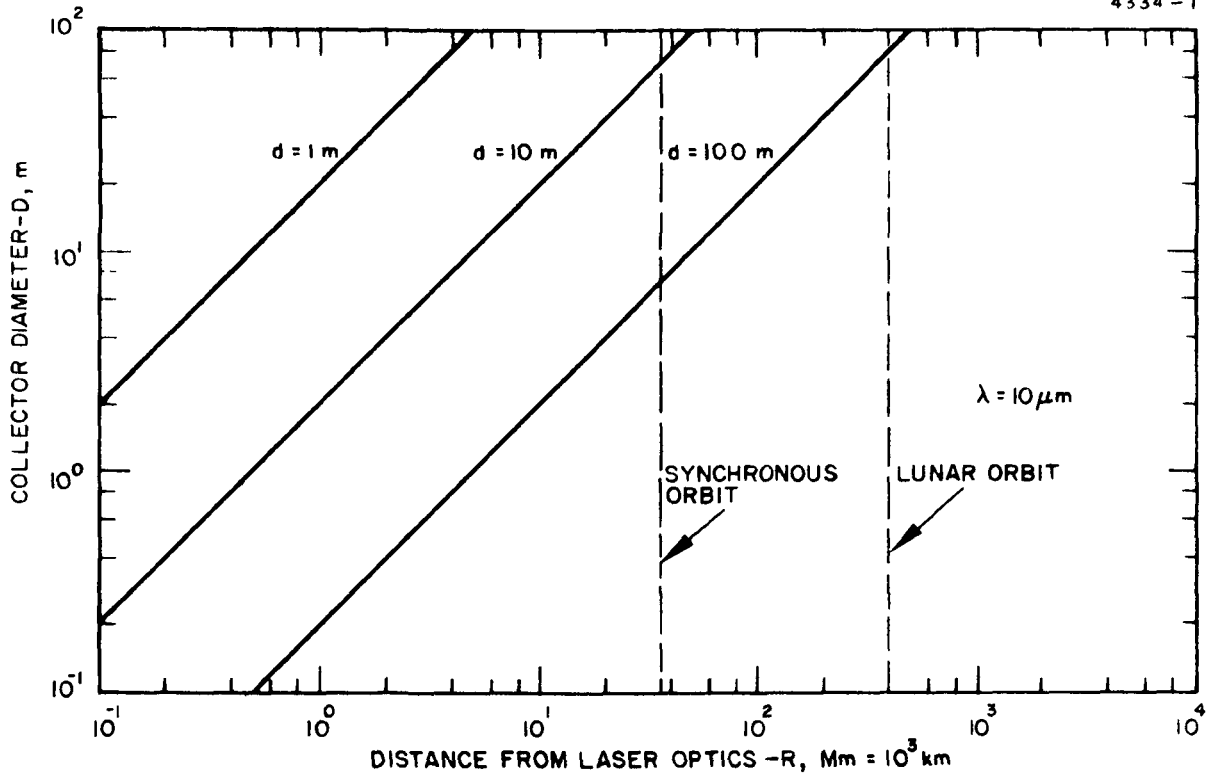

Fig. B-2. Range/optical diameter relations for 10 μm laser radiation.

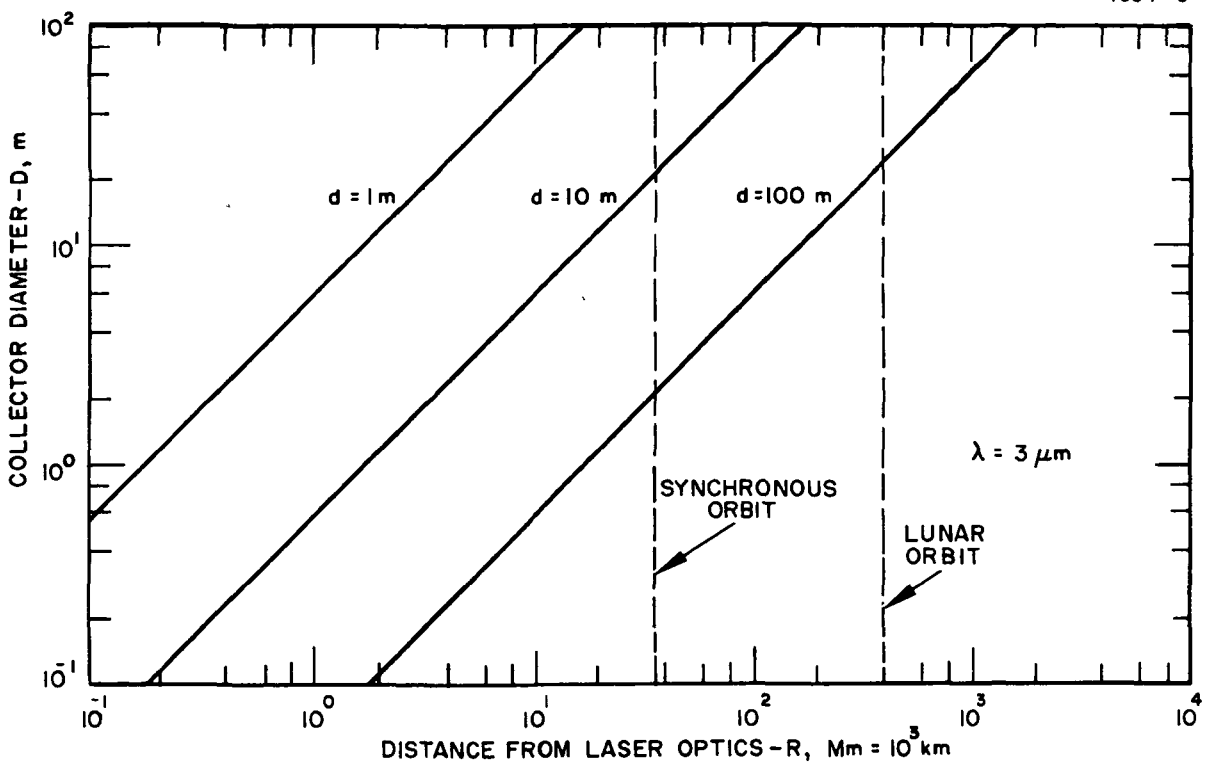

Fig. B-3. Range/optical diameter relations for 3 μm laser radiation.

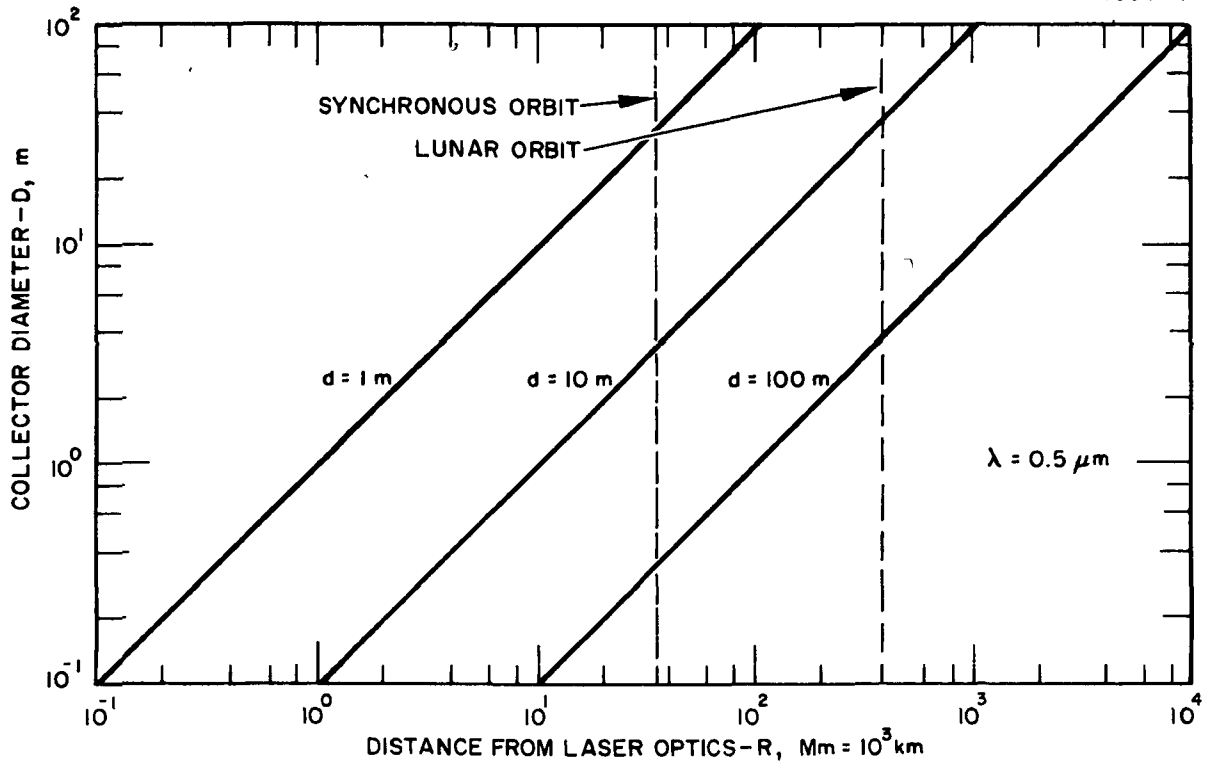

Fig. B-4. Range/optical diameter relations for 0.5 μm laser radiation.

However, the deliverable laser power/range capability and the transmitter and collector optics capability does not tell the complete story. The average laser power emitted must also be enough to do the job. If one evaluates the state of the art in lasers, we see that the unclassified average power levels presently available are not adequate for many LEP missions. Fortunately, there is a very high level of high power laser development under DoD sponsorship, as well as development on laser optics, COAT and pointing and tracking systems. Additional efforts are also underway under NASA sponsorship. A reasonable extrapolation of present day technology indicates that within 5 to 10 years we can expect to see systems with average power levels of 100 to 1000 kW over the entire optical spectrum, and phased COAT optical arrays with 30 to 1000 elements covering diameters from 1 to 30 m. These laser system capabilities are far greater than are needed for any LEP system out to lunar orbit and beyond.

APPENDIX C

COHERENT OPTICAL
ADAPTIVE TECHNIQUES
(COAT)

SUMMARY OF CONCEPT

Compiled by

Dr. Robert L. Forward
Senior Scientist,
Hughes Research Labs.

INTRODUCTION

The development of high-power lasers which can produce hundreds of kilowatts of power on a continuous basis, at reasonable efficiency, has made possible the consideration of optical systems for long-distance power transmission. With improvement in the devices themselves, and the potential for higher power levels, came the realization that severe problems will be encountered in propagating a high-power beam in the atmosphere. The major problems arise from two sources: atmospheric turbulence which produces random phase fluctuations across the beam diameter, and atmospheric absorption which produces a negative lens and thus spreads the beam (this effect is known as "thermal blooming"). Both effects may reduce the beam intensity delivered to a target, sometimes by orders of magnitude. Left uncorrected, these effects can render the laser power transmission system useless.

Over the last five years, adaptive optical array techniques have been applied to mitigating these problems. The name most generally applied to this work is "Coherent Optical Adaptive Techniques," (COAT) and is broadly interpreted to mean the use of any optical phased-array which derives its phasing signals from error signal information contained in a return or source signal from the target or receiving station.

The Hughes Aircraft Company has an extensive background in this class of system, in its supporting technology, and in the propagation problems to which it relates.

This report utilizes material generated by Hughes personnel in previous publications¹ and internal reports² to summarize the COAT concept as it is applied to transmitting power out to spacecraft in earth orbit. This is a rapidly developing field and a reader interested in knowing the

present state of the art should conduct a search of the unclassified and classified literature.

The general COAT system concept is illustrated schematically in Fig. C-1. The high power laser transmitter beam is emitted from an array of transmitting optics, each of which can be adjusted to control the relative phase of the light emitted from that portion of the array. A separate system measures the amount of wavefront distortion due to the turbulent atmosphere by one of many atmospheric measurement techniques (the type of measurement means used is the major distinction between COAT systems). The elements in the array are then adjusted so that a distorted wavefront is emitted from the transmitter, the distortions being the conjugate of the atmospheric distortions. As the distorted wavefront passes through the turbulent atmosphere, the atmospheric distortions are compensated by the initial distortions. Thus, after passage through the atmosphere, the wavefront is smooth.

ADAPTIVE PHASED ARRAY TECHNIQUES

The majority of optical adaptive phase array work to date has been directed toward operation with noncooperative targets, wherein the target serves only as a radar reflector. Two basic types of optical adaptive phase arrays are known for this purpose: (1) outgoing-wave, and (2) return-wave.

For cooperative targets, a new class of system is possible which is called a Pilot-Wave system. It is closely akin to a return-wave system. In the pilot-wave system the wavefront error information at the array is obtained from a wavefront (the pilot wave) transmitted from the space power-receiving-station as opposed to a wavefront reflected off the station.

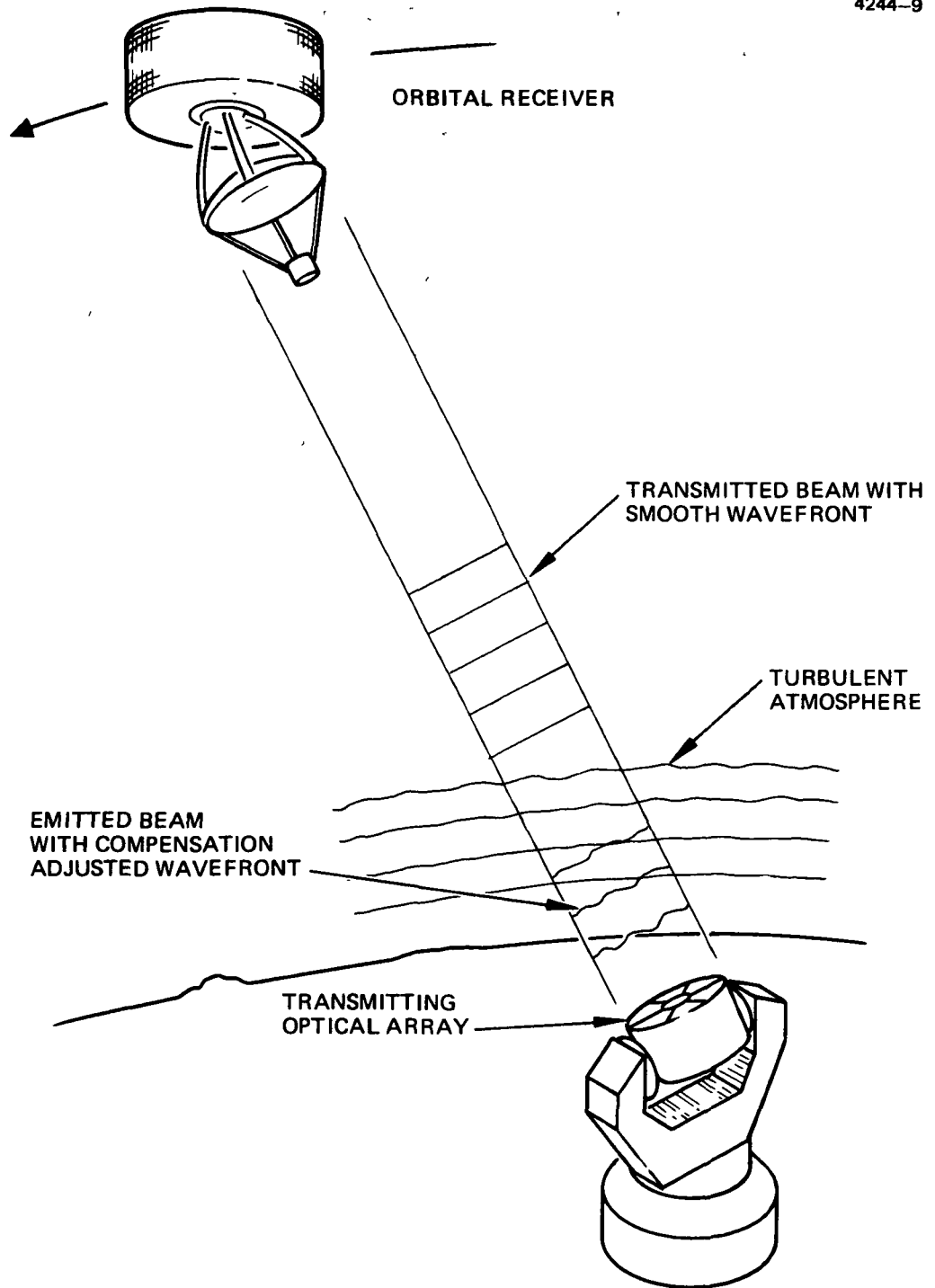

Fig. C-1. Schematic of COAT system operation.

All of these systems are capable of compensating distortions in the propagation path, and all (automatically) possess self-tracking features.

Acquisition and track of the receiver terminal can be either passive or active. Techniques to acquire and track an active receiver in a narrow bandwidth laser communication system have been investigated in depth at Hughes. Laser acquisition and track between (1) two synchronous satellites, (2) a synchronous satellite and a low altitude satellite, and (3) a synchronous satellite and an earth station are discussed in Reference 2.

Precision track of the satellite and ground station from the ground station and active satellite, respectively, can be each accomplished with a four-degree of freedom gimbaled pointing system. A mirror gimbaled about two axes is used for precision pointing. The outermost coarse gimbal provides roll and the middle coarse gimbal provides elevation. Precision tracking is accomplished by driving the two precision gimbals to maintain a zero tracking error. The two coarse gimbals in the outer tracking loop are driven to maintain the precision gimbals near null.

The present pointing and tracking capabilities of ground based and space based optical systems is classified information. For consideration for an LEP system, we can probably assume that if the present capabilities are not already adequate for the LEP system that they soon will be under the present level of DoD support for laser and optics technology.

REFERENCES

1. W.B. Bridges, et. al. "Coherent Optical Adaptive Techniques," *Applied Optics* 13, 291-300 (Feb. 1974).
2. "10.6 Micron Laser Relay Link for ATS Spacecraft" Report No. TP70-80, Aerospace Group, Hughes Aircraft Co., (18 July 1970).

APPENDIX D

RADIATION COLLECTORS
FOR SEP AND LEP

by

Dr. Eugene F. Mallove
Aerospace Consultant

INTRODUCTION

In this study we investigate the improvement in propulsion system performance obtainable by using laser energy in an LEP system rather than solar energy in an SEP system. We first estimate the collector area improvement for both a photovoltaic array and a thermal-to-electric system. We then estimate what this improvement means in terms of various important mission parameters, such as trip time and payload ratio.

PHOTOVOLTAIC ARRAY COLLECTORS

To make the comparison between SEP and LEP with planar photovoltaic arrays assumed for collector-converters, consider each system to yield equal electric power. We then have

$$\phi_S \eta_{SA} A_{SA} = \phi_L \eta_{LA} A_{LA} \quad (1)$$

where

- ϕ_L = laser light flux intensity
- ϕ_S = solar flux intensity
- η_{SA} = fractional efficiency of solar cell array in converting incident flux to electric power
- η_{LA} = fractional efficiency of cells optimized for laser wavelength ("laser array") in converting incident flux to electric power
- A_{SA} = area of broad band solar cell array
- A_{LA} = area of array of optimized cells for laser wavelength

The systems can then be compared on the basis of array areas,

$$\frac{A_{LA}}{A_{SA}} = \frac{\phi_S \eta_{SA}}{\phi_L \eta_{LA}} \quad (2)$$

For temperature limited semiconductor cells we can consider ϕ_S / ϕ_L as low as 10^{-1} (0.2 would certainly be possible)¹. The power conversion efficiency ratio, η_{SA} / η_{LA} , would perhaps be between 1/3 and 1/2. The area ratio is bracketed then by

$$0.03 \leq \frac{A_{LA}}{A_{SA}} \leq 0.1 \quad (3)$$

This indicates a substantial reduction in array area for the LEP system even with conservative assumptions.

THERMAL-TO-ELECTRIC COLLECTORS

If the comparison is made between equal power LEP and SEP systems assuming paraboloidal radiation collectors focused on thermal-to-electric power converters, we have

$$\phi_S A_{SC} \eta_{SC} \eta_{STE} = \phi_L A_{LC} \eta_{LC} \eta_{LTE} \quad (4)$$

where

- A_{SC} = projected area of solar radiation collector
- A_{LC} = projected area of laser radiation collector
- η_{SC} = efficiency of radiation to thermal energy conversion for solar collector

- η_{LC} = efficiency of radiation to thermal energy conversion for laser collector
 η_{STE} = efficiency of thermal to electric power conversion for solar system
 η_{LTE} = efficiency of thermal to electric power conversion for laser system

The area ratio for the collectors is thus,

$$\frac{A_{LC}}{A_{SC}} = \frac{\phi_S}{\phi_L} \frac{\eta_{SC}}{\eta_{LC}} \cdot \frac{\eta_{STE}}{\eta_{LTE}} \quad (5)$$

The temperature restriction on ϕ_S/ϕ_L present with photovoltaic cells does not occur with paraboloidal collectors, so ϕ_S/ϕ_L could be as small as the laser technology allows over the distance to the spacecraft. For radiation collectors ϕ_S/ϕ_L should be considered at most 0.1, and probably not much smaller to avoid a radiator mass problem. The radiation to thermal conversion efficiencies ratio, η_{SC}/η_{LC} , will be of the order of 1.0 for visible wavelength laser radiation. "Greenhouse effect" devices at the focus of the radiation collector (such as narrow transmission band Fabry-Perot filters) would be suitable for converting infrared laser wavelengths to thermal energy with high efficiency. There might be some marginal advantage in the ratio, η_{STE}/η_{LTE} , due to higher temperatures possibly available at the focus of the laser collector, but this could not even make η_{STE}/η_{LTE} as small as 1/2. The net conclusion is that the ratio of the collector areas A_{LC}/A_{SC} will be around 0.1, as it was with the photovoltaic array comparison.

PROPULSION SYSTEM PERFORMANCE

With all other system weights equal for equal power LEP and SEP systems, the potential 10-fold or greater reduction in array or collector area means significant weight savings. The total propulsion system specific mass, α (kilograms/kilowatt), is a combination of the specific mass of the collector and converter, α_0 , plus the specific mass of the rest of the propulsion system, α_e , with contributions from engines, tankage, wiring, power conditioner, etc. (excluding propellant):

$$\alpha = \alpha_0 + \alpha_e \left(\frac{\text{kilograms}}{\text{kilowatt}} \right) \quad (6)$$

In a representative design of an SEP tug designed to operate on geocentric orbits up to synchronous orbit² the collector specific mass comprised about 75% of the total power subsystem specific mass. This substantial investment in weight in the solar cell array is typical of other SEP missions which have been proposed. Reducing collector area by a factor of 0.1 with LEP could optimistically mean reducing the specific mass α to 0.3 of its SEP value. More likely, α could be cut at least in half.

In a generalized comparison of advanced propulsion concepts, W.E. Moeckel³ showed the strong effect of propulsion specific mass on mission capability. According to Moeckel, for a single stage low thrust-to-weight propulsion system we have

$$\Delta V = \left(\frac{2 T_P}{\alpha} \right)^{\frac{1}{2}} \left[1 - \gamma^{\frac{1}{2}} \right] \quad (7)$$

where

ΔV = total velocity increment imparted to the payload and dead weight propulsion system,

T_p = time of thrusting (for low thrust/weight propulsion this time is optimally at least 2/3 of total mission time)

α = total specific mass of propulsion system

γ = payload ratio = $\frac{\text{mass of payload}}{\text{total vehicle mass initially}}$

There are three ways of looking at (7):

1. For fixed thrust time T_p and payload ratio γ we have increased ΔV for lower specific mass α according to $\alpha^{-1/2}$.
2. For fixed ΔV and thrust time T_p we have increased payload ratio γ directly dependent on α ,

$$\gamma = \left(\left(\frac{\alpha}{2 T_p} \right)^{\frac{1}{2}} \Delta V - 1 \right)^2 \quad (8)$$

3. For fixed ΔV and payload ratio γ we have thrust time T_p directly dependent on α ,

$$T_p = \frac{\alpha \Delta V^2}{2 \left[1 - \gamma^{\frac{1}{2}} \right]^2}, \quad (9)$$

where T_p is on the order of total mission time.

Decreasing the propulsion specific mass α by 1/2 at fixed T_p and γ therefore multiplies the attainable ΔV by $\sqrt{2}$. For fixed ΔV and γ , reducing α by 1/2 cuts the thrust time T_p by 1/2. For fixed ΔV and T_p the percentage increase in payload ratio γ with decreasing α depends on the magnitude of the ratio $\Delta V/T_p^{1/2}$.

CONCLUSIONS

This study indicates that significant improvements in electric propulsion system performance are theoretically possible with a properly designed laser electric propulsion system that is able to use the higher energy flux and higher conversion efficiencies possible with laser light. The major improvement in performance comes from the reduction in collector area needed for an LEP system as compared to an SEP system. Laser collector area reductions to 1/10th that of solar collector areas would provide comparable weight reductions and reduce the propulsion system specific mass to 0.5 (or better) of SEP values. This would then result in improvement in payload ratio and ΔV and/or decreased thrust time for a given mission.

REFERENCES

1. R.D. Arno, J.S. MacKay and K. Nishioka, "Applications Analysis of High Energy Lasers" NASA TM X-62142 (March 1972).
2. E.D. Harney, U.E. Lapins, and J.H. Molitor, "Geocentric Solar Electric Propulsion Vehicle Design" AIAA Paper 72-1126. Presented at AIAA/SAE 8th Joint Propulsion Specialist Conference, New Orleans, Louisiana (29 Nov - 1 Dec 1972).
3. W.E. Moeckel, "Propulsion by Impinging Laser Beams" J. Spacecraft and Rockets, 9, 942 (Dec 1972).

APPENDIX E

CONVERSION OF
LASER LIGHT TO
ELECTRICITY

by

Dr. Eugene F. Mallove
Aerospace Consultant

In this study we want to draw comparisons between LEP and SEP based on our radiation-to-electric power conversion options. The converters that exist or have been proposed for laser radiation are listed in Table E-1, along with their demonstrated and projected conversion efficiencies. Silicon solar cells have been used routinely on spacecraft to achieve solar radiation to electric power conversion efficiencies around 10%. Solar cells are the only method thus far employed to convert solar radiation to electric power in space. They suffer the considerable disadvantage of being susceptible to radiation damage and consequent efficiency degradation during passage through the earth's Van Allen radiation belts. Gallium arsenide semiconductor cells, in particular, have been shown¹ to achieve substantially better conversion efficiency at specific optimum visible laser wavelengths and would therefore be more suitable for laser light conversion. The efficiency of GaAs cells, like that of silicon solar cells, suffers the same temperature sensitivity which limits the possible incident radiation flux to an upper limit maximum of about 10 times solar flux at 1.0 A.U. (Reference 2).

Thermal energy to electric power conversion by a heat engine coupled to an electric generator, thermoelectric converters, and thermionic converters all require a radiation collector (optimally a parabolic reflector) to concentrate the incoming flux in order to produce their necessary elevated temperatures.

The "photon engine" concept³ of Hertzberg is really a reverse laser which has a claimed ideal conversion efficiency of $\sim 100\%$. However, the photon engine is totally untried and nowhere near the hardware stage, so it should not be considered a real candidate for LEP.

Table E-1. Radiation-to-Electric Power Conversion Options
(Values from Ref. 4)

Converter	Demonstrated Efficiency, % $\left(\frac{P_E}{P_{IN}}\right)$	Ultimate Efficiency, % $\left(\frac{P_E}{P_{IN}}\right)$	Major Problems
Silicon Solar Cells	>20 (laser light)	>40 (with laser light)	Not optimum for laser wavelengths - upper flux limit
Semiconductor Cells optimized for a visible wavelength	42	90	Upper flux limit due to thermal problems (Van Allen Belt Degradation)
Thermal to Electric Conversion by Heat Engine coupled to Electric Generator	40%	60%	Radiator, heat engine, generator weight penalty
Thermoelectric Converter (lead telluride)	8	11	Low Efficiency
Thermionic Converter	15 to 20	25 to 30	
Reversible Laser ³ Photon Engine	None	~100	Principle is far from hardware demonstration stage

REFERENCES

1. J. Ewan, G.S. Kamath and R.C. Knechtli, "Large Area GaAlAs/GaAs Solar Cell Development" Proc. IEEE/AIAA Photovoltaic Spec. Conf., Phoenix, Arizona (1975).
2. R.D. Arno, J.S. MacKay and K. Nishioka, "Applications Analysis of High Energy Lasers" NASA TM X-62142 (March 1972).
3. A. Hertzberg, E.W. Johnson and H.G. Ahlstrom, "Photon Generators and Engines for Laser Power Transmission" AIAA Paper 71-106, (25-27 Jan. 1971).
4. K. W. Billman, "Laser Energy Conversion Symposium," NASA TM X-62269 (Sept 1973).

0

APPENDIX F

FREQUENCY CONVERSION
OF
LASER LIGHT

by

Stan A. Kokorowski
Member of the Technical Staff
Hughes Aircraft Company

INTRODUCTION

Most high energy lasers produce light in the infrared (10.6 μm) and near infrared (3.5 μm to 1.0 μm) where photovoltaic device efficiencies are very low. If we wish to consider the use of these well developed high energy IR laser sources for a Laser Electric Propulsion (LEP) system, we must find a way to efficiently convert the laser light energy into electrical power.

We have three basic alternatives.

1. Develop photovoltaic or other power converters that efficiently produce electrical power from the IR laser light.
2. Up-convert the IR laser light to the visible or near UV spectrum where photovoltaic efficiencies are highest.
3. Down-convert the laser light to frequencies in the millimeter wave or microwave region where there exist efficient power rectifiers.

The purpose of this study is to explore the fundamental principles which govern frequency conversion of laser light to determine the limitations that might be imposed on the conversion efficiency by the fundamental relations. At the start of the study, it was known that it is theoretically possible to up-convert laser light with 100% efficiency, and that efficiencies much greater than 50% had been achieved at low power levels under laboratory conditions. (For every two or three IR photons in, one visible or UV photon came out.) The fundamental limitations on down-conversion were not obvious, however, and the study concentrated on that aspect of frequency conversion.

BASIC PRINCIPLES OF COHERENT FREQUENCY CONVERSION

Δ

In order for any coherent oscillatory, electrical, mechanical or other energy to be transformed from one form to another by coherent conversion, the oscillatory modes being considered must be coupled. This may be explained briefly as follows. Consider an oscillatory electrical system, (e.g., an electric circuit). The components of this system will have various values of impedance or admittance and they will interact with electromagnetic fields and currents which are specified over some given frequency spectrum. If the interactions with the fields and currents are always first order, then the system is said to be linear and an oscillation at any one frequency is independent of oscillations at all other frequencies. The oscillatory modes are then said to be uncoupled. If, on the other hand, these interactions are higher than first order, then an oscillation at one frequency may be influenced by oscillations at other frequencies. The system is then said to be nonlinear and the modes are said to be coupled.

The fundamental principles which govern energy flow between coupled modes were first analyzed by Manley and Rowe¹. By considering a purely reactive nonlinear element which was assumed to interact with electromagnetic oscillations at a number of different frequencies, they were able to apply conservation of energy principles and derive a set of relations that relate the powers at the various frequencies. These relations can be applied to a system composed of freely propagating laser energy at several different frequencies, which is incident on some general nonlinear element. Referring to Fig. F-1, let $\omega_0, \omega_1 \dots \omega_n$ be the incident frequencies. These interact with the nonlinear element to produce a new spectrum of radiation at $\omega_0', \omega_1', \dots \omega_m'$ which emerges from the element.

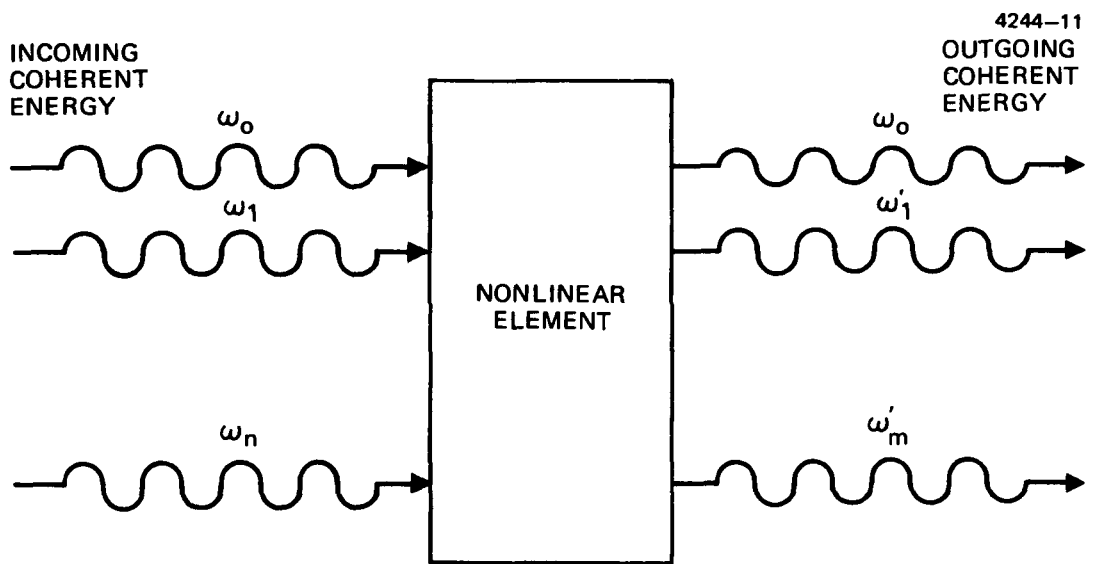

Fig. F-1. Schematic of frequency conversion of coherent radiation.

The outgoing frequencies must be related to the incident frequencies, either as pure harmonics or as sums and differences of any two harmonics.

The representation in Fig. F-1 need not be limited to incoming and outgoing radiation. Some of the frequencies may be associated with other forms of energy, (e.g., alternating current, mechanical oscillations etc.): Such energy may also interact with the radiation through a nonlinear coupling mechanism.

Up to this point this discussion is completely general. "n" arbitrary modes have been assumed to transfer power into a nonlinear element and "m" modes have been assumed to carry power out. Although there are an infinite number of harmonic frequencies and sum and difference frequencies that are allowed for the outgoing modes, only a small number of these will be present in general. The number of waves as well as the frequency of each is of course dependent on the specific properties of the nonlinear element as well as on the frequencies of the incident waves. The nature of the nonlinear element has been deliberately kept vague so that the most general situation could be considered.

In the following section a somewhat less general situation will be analyzed. A hypothetical frequency down-converter will be developed by allowing only three oscillatory modes to interact with an unspecified nonlinear element.

GENERAL MODEL OF A FREQUENCY DOWN CONVERTER

In the following, a very simple, yet very general model of a radiation frequency converter will be developed. The Manley-Rowe¹ power relations will be the only physical principles considered. Although these relations² are very general in their application, some very specific guidelines

for frequency conversion may be developed. The model consists of four components as shown in Fig. F-2. A plane electromagnetic wave of frequency ω_0 is incident on a nonlinear element which couples this wave with energy at a frequency ω_p . In the process another electromagnetic wave at frequency ω_1 is created. The energy at ω_p will be referred to as the pump mode and will remain unspecified. It may be another plane wave incident on the nonlinear element or it may be a mechanical mode of vibration in the element itself or any conceivable energy storing devices. The direction of power flow via this mode will also remain unspecified for now, but will be deduced later.

It is felt that these are the minimum specifications that must be imposed on a frequency converting system. A more complex system could include more than one incident and one outgoing wave and more than one pump mode.

Because of the nature of nonlinear interactions ω_1 will always have the following form.¹

$$\omega_1 = m\omega_0 + n\omega_p \quad (1)$$

where: m, n are integers from $-\infty$ to ∞ . For example, the following nonlinear product may always be expanded in a Fourier series as shown, where the highest harmonic will be the sum, $k\omega_0 + l\omega_p$.

$$\begin{aligned} (\sin \omega_0 t)^k (\cos \omega_p t)^l = & \sum_{m=0}^k \sum_{n=0}^l \left[A_{mn} \sin (m\omega_0 t + n\omega_p t) \right. \\ & \left. + B_{mn} \cos (m\omega_0 t + n\omega_p t) \right] \quad (2) \end{aligned}$$

Without loss of generality we can restrict ω_0 and ω_p to positive values.

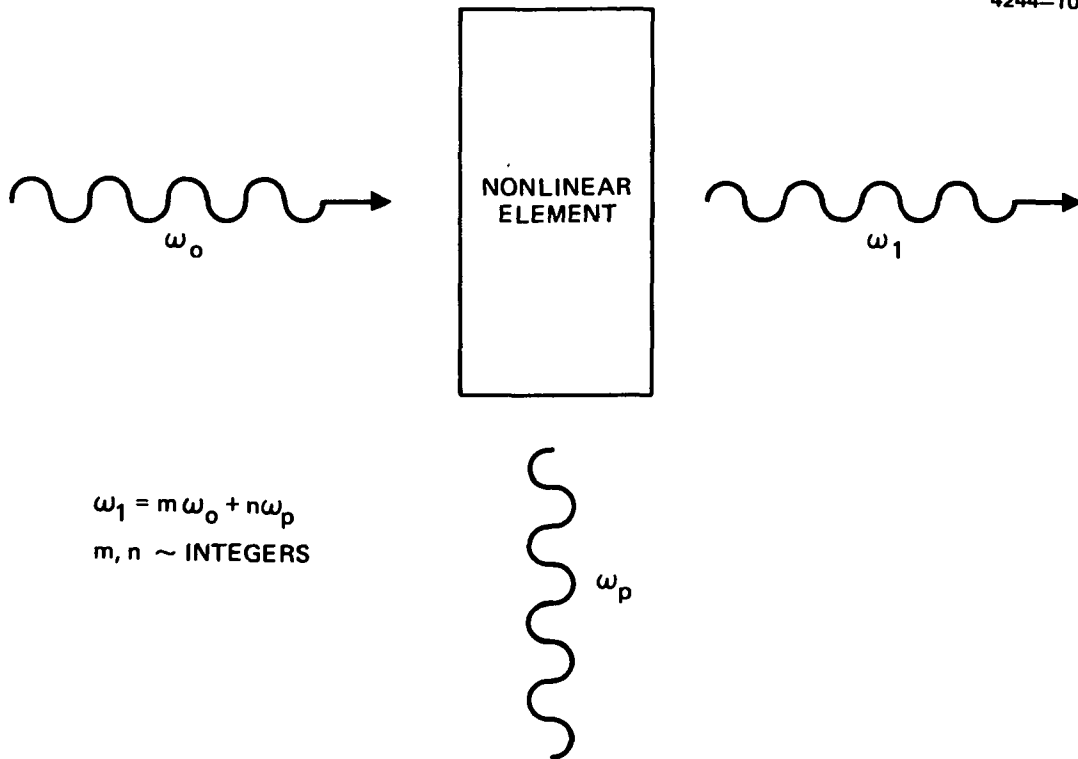

Fig. F-2. Schematic of down-conversion of coherent radiation.

Generally speaking the more nonlinear the element, or equivalently, the higher the order of the nonlinear interaction, the higher the number of harmonics that may be generated.

Having defined the model, the Manley-Rowe relations will now be imposed so that some useful properties of the system may be deduced. A brief and simple derivation of these relations may be found in Chapter 4.4 of Louisell.² The notation used in that reference will be adopted here for convenience. Define:

$$\Omega_{mn} \equiv m\omega_0 + n\omega_p \quad (3)$$

Then:

$$\omega_0 = \Omega_{10} \quad (4)$$

$$\omega_p = \Omega_{01} \quad (5)$$

$$\omega_1 = \Omega_{mn}$$

where n and m are two specific integers. P_{mn} will refer to the power flow at frequency Ω_{mn} . A single subscript will also be used for the following three cases: $P_0 \equiv P_{10}$, $P_p \equiv P_{01}$, and $P_1 \equiv P_{mn}$ where it is simpler to do so. The Manley-Rowe relations are then expressed as:

$$\sum_{m=0}^{\infty} \sum_{n=-\infty}^{\infty} \frac{m P_{mn}}{\Omega_{mn}} = 0 \quad (7)$$

$$\sum_{m=-\infty}^{\infty} \sum_{n=0}^{\infty} \frac{n P_{mn}}{\Omega_{mn}} = 0 \quad (8)$$

The above equations may be interpreted as a conservation of energy statement inside the nonlinear element. At this point it is convenient to require that $|\omega_1| < |\omega_0|$. This allows ω_1 to be expressed as:

$$\omega_1 \equiv \mu\omega_0 - \nu\omega_p \quad (9)$$

where μ and ν are either both positive or both negative

The Manley-Rowe relations for this model may now be expressed:

$$\frac{P_{10}}{\Omega_{10}} + \frac{\mu P_{\mu-\nu}}{\Omega_{\mu-\nu}} = \frac{P_0}{\omega_0} + \frac{\mu P_1}{\mu\omega_0 - \nu\omega_p} = 0 \quad (10)$$

$$\frac{P_{01}}{\Omega_{01}} + \frac{\nu P_{-\mu\nu}}{\Omega_{-\mu\nu}} = \frac{P_p}{\omega_p} - \frac{\nu P_1}{\mu\omega_0 - \nu\omega_p} = 0 \quad (11)$$

Using equations 10 and 11 gives:

$$P_1 = - (1-\rho) P_0 \quad (12)$$

$$P_p = - \rho P_0 \quad (13)$$

where ρ has been defined as:

$$\rho \equiv \frac{\nu\omega_p}{\mu\omega_0} \quad (14)$$

The above equations, although very simple, contain a lot of information. Because of the negative sign in equation 13, power must always flow from the incident wave into the pump mode. This is a consequence of the restriction that $|\omega_1| < |\omega_0|$ which required ν and μ to have the same sign. From equation 12 it is obvious that in order for power to flow into the outgoing wave ρ must be less than 1. Not only should ρ be less than one, but if most of the power is to flow into the outgoing wave then ρ should approach zero. This has an undesirable side effect in that, as ρ approaches zero, $|\omega_1|$ increases.

$$\omega_1 = (1-\rho) \mu \omega_0 \quad (15)$$

This presents a severe problem if a very large decrease in frequency is desired. One has to compromise between maximum energy transfer to the outgoing wave and maximum reduction in frequency. The optimum value of ρ will depend on the physical nature of the nonlinear element. This has been left deliberately ambiguous to preserve the general applicability of this study.

Since a significant amount of energy must always flow into the pump mode it becomes imperative that this energy be recovered and used in succeeding steps in order to achieve practical efficiencies. If the pump frequency $\omega_p \neq \omega_1$, which is the case in general, then the second step will require that power at these two different frequencies flow into a second nonlinear element. This will require a new model for a frequency converter which allows power to flow into it at two frequencies instead of just one. This is slightly more

complex than the original model, and would undoubtedly lead to a more complex form of power outflow. In the third step the complexities increase again and so on. The problem grows rapidly.

There is a theoretical way out of this confusion if one assumes that the energy in the pump mode may be recovered as electromagnetic radiation at the frequency ω_1 , either by a suitable nonlinear element or by an intermediate process. In terms of this model it can just be assumed that there are two plane waves leaving the nonlinear element at frequencies ω_1 and ω_p , and that $\omega_p = \omega_1$. These two waves are said to be degenerate and may be considered as just one wave. The identical process can then be repeated by letting this new wave be incident on a second nonlinear element. The number of steps required in this case still depends on what the physical properties of the nonlinear element are. These properties will determine the values of the integers μ and ν , which will in turn determine the value of ρ .

It will be very useful to examine the required relationships between μ , ν and ρ which allow the above process to work. First note that the restriction $\omega_1 = \omega_p$ requires:

$$\rho = \frac{\nu\omega_1}{\mu\omega_0} \quad (16)$$

This combined with equation 15 gives:

$$\rho = \frac{\nu}{\nu+1} \quad (17)$$

Thus ρ has a minimum value of $1/2$ and a limiting value of 1 as $\nu \rightarrow \infty$

$$\rho = \frac{1}{2}, \frac{2}{3}, \frac{3}{4}, \frac{4}{5}, \dots, 1 \quad (18)$$

This is interesting because it says that there is a preference of one degenerate mode over the other, in spite of the fact that they have the same frequency. One should note that although there may be no distinction between these modes when the two waves are incident on the second nonlinear element they may still be distinguishable when they are extracted from the first. Thus it may be possible to allow most of the energy to flow into the preferred mode. This would have the advantage of allowing large reductions in frequencies in a very few steps, even as few as one. For example, assume $\rho \approx 1$. Then by eqs. 12 and 13 almost all of the power will flow into the pump mode. But since ω_1 is assumed equal to ω_p , eq. 15 shows that ω_p approaches zero. In order to achieve this very favorable condition, a highly nonlinear element is required. For according to eq. 17, as $\rho \rightarrow 1$, $\nu \rightarrow \infty$.

As an example of what can be done, Yarborough, et al,^{3,4} in 1969 used the 248 cm^{-1} nonlinear polariton mode in LiNbO_3 to downconvert pulsed ruby laser light at $0.69 \mu\text{m}$ ($4.3 \times 10^{14} \text{ Hz}$) by a factor of 345 to $238 \mu\text{m} = 0.238 \text{ mm}$ ($1.3 \times 10^{12} \text{ Hz}$) at greater than 50% efficiency without the use of resonator circuits.

If a similar reduction could be obtained at high average power levels with $10.6 \mu\text{m}$ laser light, the IR laser radiation could be converted to 3.6 mm microwave radiation, which could then be rectified with a microwave diode array to produce dc electrical power with greater than 50% efficiency.

However, the problem of finding a material with a non-linear response that will down convert IR radiation with high efficiency and without damage at high average laser powers (100 kW ave) and the problem of developing a microwave diode rectifier array to handle these power levels efficiently (a single diode can only handle 10 mW) are significant. A substantial R&D effort on these problems will be needed before such a concept could be used in designing an LEP system.

CONCLUSIONS

An examination of the fundamental Manley-Rowe relations governing the coherent conversion of laser light to other frequencies of electromagnetic radiation has uncovered no fundamental relations that will prohibit 100% conversion of the energy from one form to another either in up-conversion or down-conversion. Although efficient upconversion from the near IR to the visible and down-conversion from the visible to the very long IR has been demonstrated in the laboratory, operation at high average powers suitable for LEP system consideration has not been demonstrated. For LEP systems using 10.6 μm CO_2 lasers, it would be desirable to have up-conversion by a factor of 20 or down conversion by a factor of 400 to reach the spectral regions where there exist efficient converters of electromagnetic radiation into electrical currents suitable for powering an LEP system. Although there are no fundamental limitations on down- or up-conversion by these factors, the practicality of such a process has yet to be demonstrated. Further research and development will be needed before laser frequency conversion can be seriously considered for LEP systems.

REFERENCES

1. J.M. Manley and H.E. Rowe, "Some General Properties of Nonlinear Elements - Part I General Energy Relations", IRE Vol. 44, p. 904, July 1956.
2. W.H. Louisell, "Coupled Mode and Parametric Electronics," John Wiley and Sons, New York - London, 1960.
3. S.E. Harris, "Tunable Optical Parametric Oscillators" Proc. IEEE, 57, 2096 (Dec. 1969), (An invited review paper with 98 references.)
4. J.M. Yarborough, S.S. Sussman, H.E. Purhoff, R.H. Pantell and B.C. Johnson, "Efficient, Tunable Optical Emission from LiNbO_3 Without a Resonator," Appl. Phys. Lett. 15, 102 (Aug. 1969).

APPENDIX G

COMPARISON OF LEP AND SEP
THERMAL CYCLES

by

Dr. Eugene F. Mallove
Aerospace Consultant

NOMENCLATURE

α_1	=	Turbine Specific Mass (kg/kW)
α_2	=	Specific Mass of Electric Generator (kg/kW)
α_3	=	Specific Mass of Radiator/Condenser (kg/kW)
α_4	=	Area-Specific Mass of Radiation Collector (kg/m ²)
α_5	=	Area-Specific Mass of Boiler (kg/m ²)
α_e	=	Total power system specific mass (kg/kW)
ϵ_1	=	Absorptivity of Boiler
ϵ_2	=	Emissivity of Boiler
ϵ	=	Emissivity of Radiator
ϕ	=	Power Density of Incident Radiation (kW/m ²)
T_1	=	Temperature at Turbine Inlet
T_3	=	Surface Temperature of Boiler
T_2	=	Temperature of Outer Radiator Surface
A_b	=	Area of Boiler Heated by Focussed Radiation
R	=	Radius of Radiation Collector
η	=	Fractional Reduction in Carnot Efficiency of Turbine
P_e	=	Electrical Power Generated
P_m	=	Mechanical Power Developed by Turbine
P_f	=	Power Given to Working Fluid at Boiler
σ	=	Stefan-Boltzmann Constant
r	=	Radiator Area-Specific Mass (kg/m ²)

INTRODUCTION

The following analysis is adapted from a discussion of solar propulsion systems by H. Ruppe¹. Our objective is to determine whether a significant specific mass reduction is possible in going from an SEP system with thermal cycle power conversion to an LEP system with thermal cycle power conversion. The relative collector size is the main avenue of expected improvement, though reduction in required pointing accuracy might be an added benefit.

The baseline system for analysis is the turboelectric one illustrated in Fig. G-1. For now, the mechanical construction of the collector is left indefinite. Two of the most important parameters are T_1 , the temperature at turbine inlet, and T_2 , the temperature at turbine outlet. (See nomenclature.)

The following relationships then hold. Power given to working fluid at boiler assuming collector reflects 95% of incident power on boiler:

$$P_f = \epsilon_1 (.95) \phi \pi R^2 - \epsilon_2 \sigma T_3 A_b \quad (1)$$

The Carnot efficiency (theoretical maximum) of the turbine is $\frac{T_1 - T_2}{T_1}$, hence the mechanical power developed by the turbine is

$$P_m = \eta \left[\frac{T_1 - T_2}{T_1} \right] P_f \quad (2)$$

The electric power generated assuming 95% mechanical-to-electric conversion efficiency is:

$$P_e = (.95) \eta \left[\frac{T_1 - T_2}{T_1} \right] \left(\epsilon_1 (.95) \phi \pi R^2 - \sigma T_3 A_b \right) \quad (3)$$

$$\text{Collector Mass} = \alpha_4 \pi R^2 \quad (4)$$

$$\text{Boiler Mass} = \alpha_5 A_b \quad (5)$$

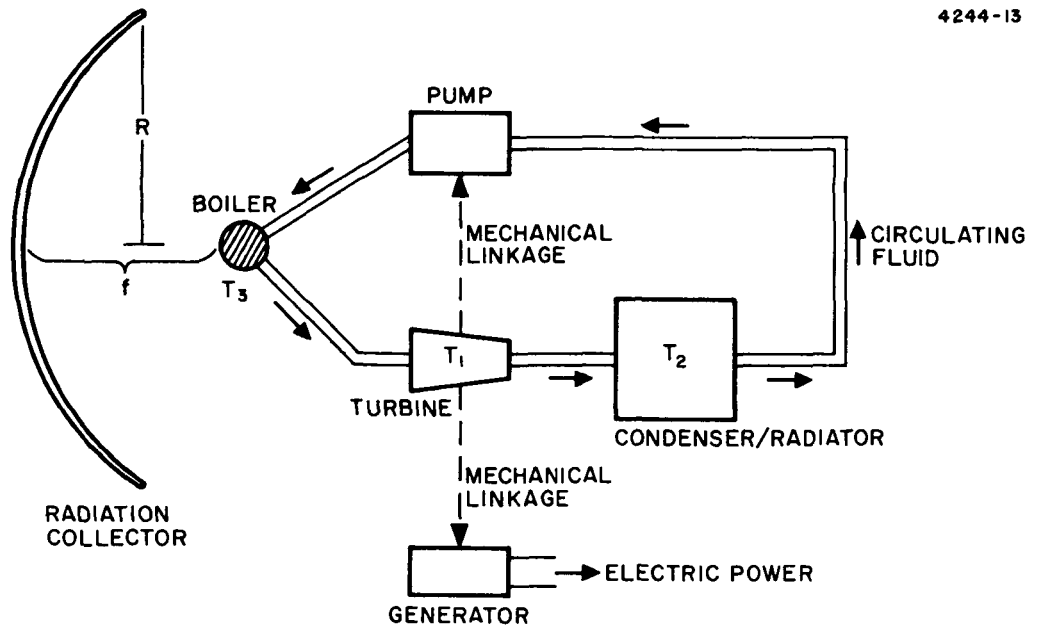

Fig. G-1. Baseline solar or laser turboelectrical system.

Radiator/condenser Mass =

$$\frac{r}{\epsilon \sigma T_2^4} \left(\epsilon_1 (.95) \phi \pi R^2 - \epsilon_2 \sigma T_3^4 A_b \right) \left(1 - \eta \frac{T_1 - T_2}{T_1} \right) \quad (6)$$

$$\text{Turbine Mass} = \alpha_1 \eta \frac{T_1 - T_2}{T_1} \left(\epsilon_1 (.95) \phi \pi R^2 - \epsilon_2 \sigma T_3^4 A_b \right) \quad (7)$$

$$\text{Generator Mass} = \alpha_2 \eta \frac{T_1 - T_2}{T_1} \left(\epsilon_1 (.95) \phi \pi R^2 - \epsilon_2 \sigma T_3^4 A_b \right) \quad (8)$$

The total power system specific mass, α_e (kg/kW) is given by the sum of the above masses divided by P_e . Ruppe¹ shows

$$\alpha_e = 1.05 \left[\frac{\alpha_4 + \beta \alpha_5}{(.95) \epsilon_1 \phi \eta (1-x) (1-\gamma \tau^4)} + \frac{\alpha_3}{\tau^4} \left(\frac{1/\eta - 1+x}{x^4 (1-x)} \right) + \alpha_1 + \alpha_2 \right] \quad (9)$$

where the following substitutions for complex notation have been incorporated:

$$\alpha_3 = \frac{r}{\epsilon \sigma (1400)^4} \quad (10)$$

$$x = \frac{T_2}{T_1} \quad (11)$$

$$\tau = \frac{T_1}{1400} \quad (12)$$

$$\beta = \frac{A_b}{\pi R^2} \quad (13)$$

$$\gamma = \frac{321}{\phi} \left(\frac{\epsilon_2}{\epsilon_1} \right) \beta \quad (14)$$

Generally for reasons of structural integrity of the turbine at high temperature, we must have say

$$T_1 \leq 1400^{\circ}\text{K}. \quad (15)$$

We consider the case of a so-called "Ehrlicke Sphere" collector which is an inflatable mylar sphere with reflective surface on one-half of the inner side -- essentially a spherical mirror. Ruppe¹ showed that $\beta = A_b/\pi R^2$ for this type of collector would be about 7×10^{-3} . Reasonable values of ϵ_1 and ϵ_2 for the boiler are 0.9 and 0.3 respectively, so we have

$$\gamma = \frac{321}{\phi} \left(\frac{\epsilon_2}{\epsilon_1} \right) \beta = \frac{0.75}{\phi}. \quad (16)$$

It is desired to minimize α_e with respect to both $x \left(= \frac{T_2}{T_1} \right)$ and $\tau \left(= \frac{T_1}{1400^{\circ}\text{K}} \right)$. Ruppe¹ showed that the minimization of Equation 9 with respect to x and τ results in the equations:

$$u - c = \left[4c \frac{y - 1}{y^4} + \frac{1}{(2y^4)^2} \right]^{\frac{1}{2}} - \frac{1}{2y^4} \quad (17)$$

and

$$\eta = \frac{y^4 - c/(u-c)^2}{y^3(y-1)} \quad (18)$$

where

$$b = (\alpha_4 + \beta\alpha_5) / \alpha_3 \quad (19)$$

$$c = \frac{\gamma}{b} \quad (20)$$

$$z = \frac{1}{\tau^4} \quad (21)$$

$$u = \frac{z}{b} \quad (22)$$

and

$$y = \frac{1}{x} = \frac{T_1}{T_2} \quad (23)$$

It has been assumed that $\alpha_1 = \alpha_2 = 1.0 \frac{\text{kg}}{\text{kW}}$. To use Equations (17), (18), and (9) to get minimum α_e we employ the following steps:

1. Select reasonable value of b

$$\alpha_5 \sim 10 \frac{\text{kg}}{\text{m}}$$

$$\alpha_4 \sim 0.1 \frac{\text{kg}}{\text{m}^2}$$

$$\beta = 7 \times 10^{-3}$$

$$\alpha_3 = 0.025 \frac{\text{kg}}{\text{kW}}$$

$$b \sim 6.80$$

$$\left. \begin{array}{l} \alpha_5 \sim 10 \frac{\text{kg}}{\text{m}} \\ \alpha_4 \sim 0.1 \frac{\text{kg}}{\text{m}^2} \\ \beta = 7 \times 10^{-3} \\ \alpha_3 = 0.025 \frac{\text{kg}}{\text{kW}} \end{array} \right\} \text{Based on } r = \frac{5 \text{ kg}}{\text{m}}$$

2. Choose incident radiation flux, $\phi \frac{\text{kW}}{\text{m}^2}$, which determines γ by Equation 16, and thereby determines c.
3. Using Equation (17) pick a reasonable value of y and then find u, then τ (or T_1) from Equations (21) and (22).
4. Find η using Equation (18) and α_e using Equation (9).

5. Graph τ, α_e, η, y as in Figures G-2 and G-3, pick another y , and go back to Step 3.
6. Select optimum system graphically.

CONCLUSION

For SEP thermal cycle system near earth, we have $\phi = 1.4 \frac{\text{kW}}{\text{m}^2}$, $\gamma = 0.54$, $c = 7.94 \times 10^{-2}$. Figure 2 shows α_e, y , and τ as functions of the fractional reduction in turbine Carnot efficiency actually achieved. $\eta = .5$ is pessimistic, and $\eta = .9$ is optimistic.

For LEP thermal cycle system with $\phi = 7.0 \text{ kW/m}^2$, $\gamma = 0.1071$ and $c = 1.57 \times 10^{-2}$. By comparing Figure 3 for the LEP system with Figure 2 for the SEP system it is readily seen that the specific mass (α_e) improvement is slight. The Ehricke sphere collector is simply not a dominant system mass. Also note that the absolute magnitudes of the power system specific mass (α_e) for both SEP and LEP thermal cycles are comparable to α_e for photovoltaic LEP and SEP. Other types of more massive collectors (paraboloidal) could be analyzed similarly and might yield slightly different conclusions.

REFERENCE

1. H. O. Ruppe, Introduction to Astronautics, Vol.2, Academic Press, New York (1967).

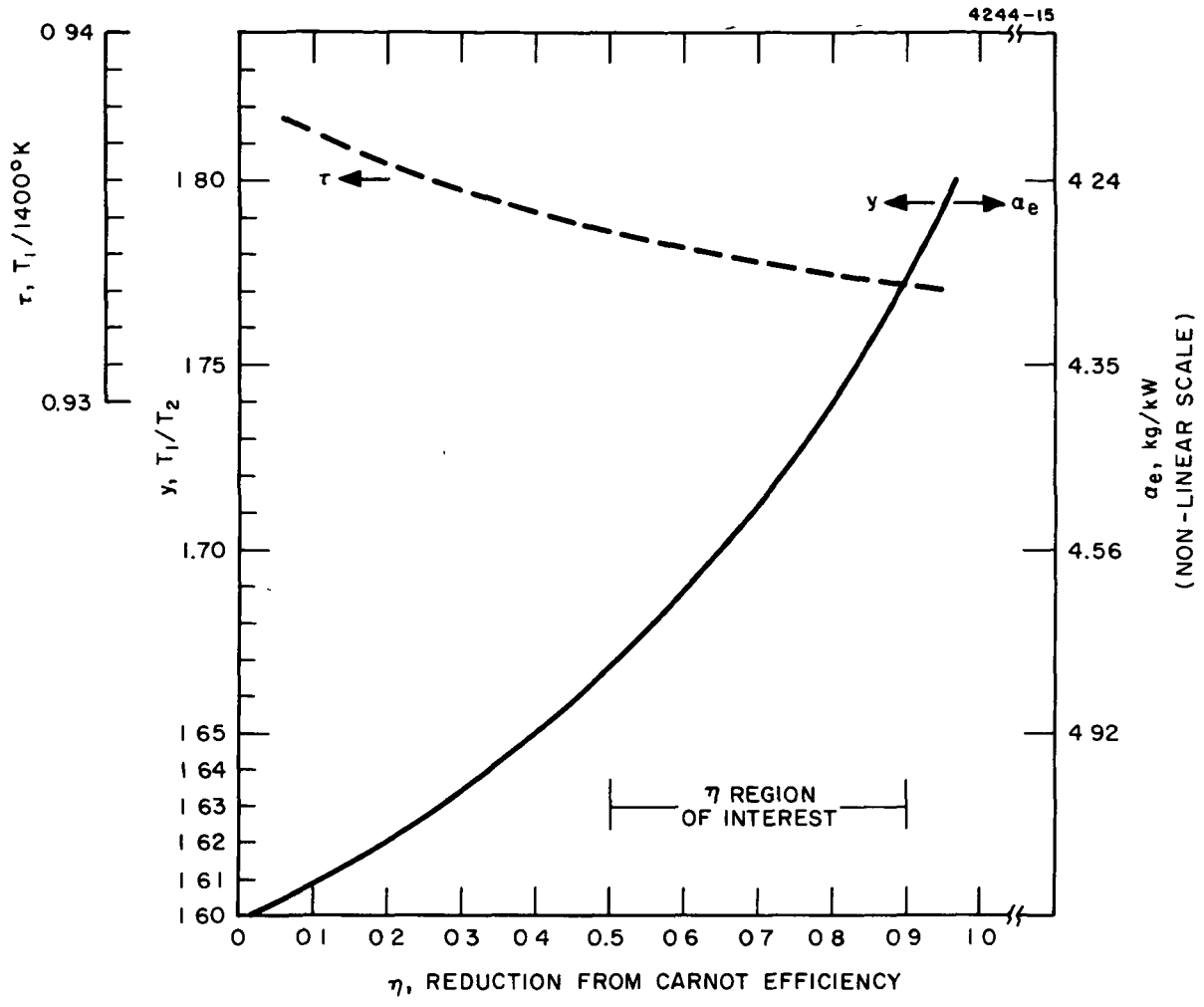

Fig. G-2. Optimization of SEP Thermal Cycle System with Ehrlicke Sphere.

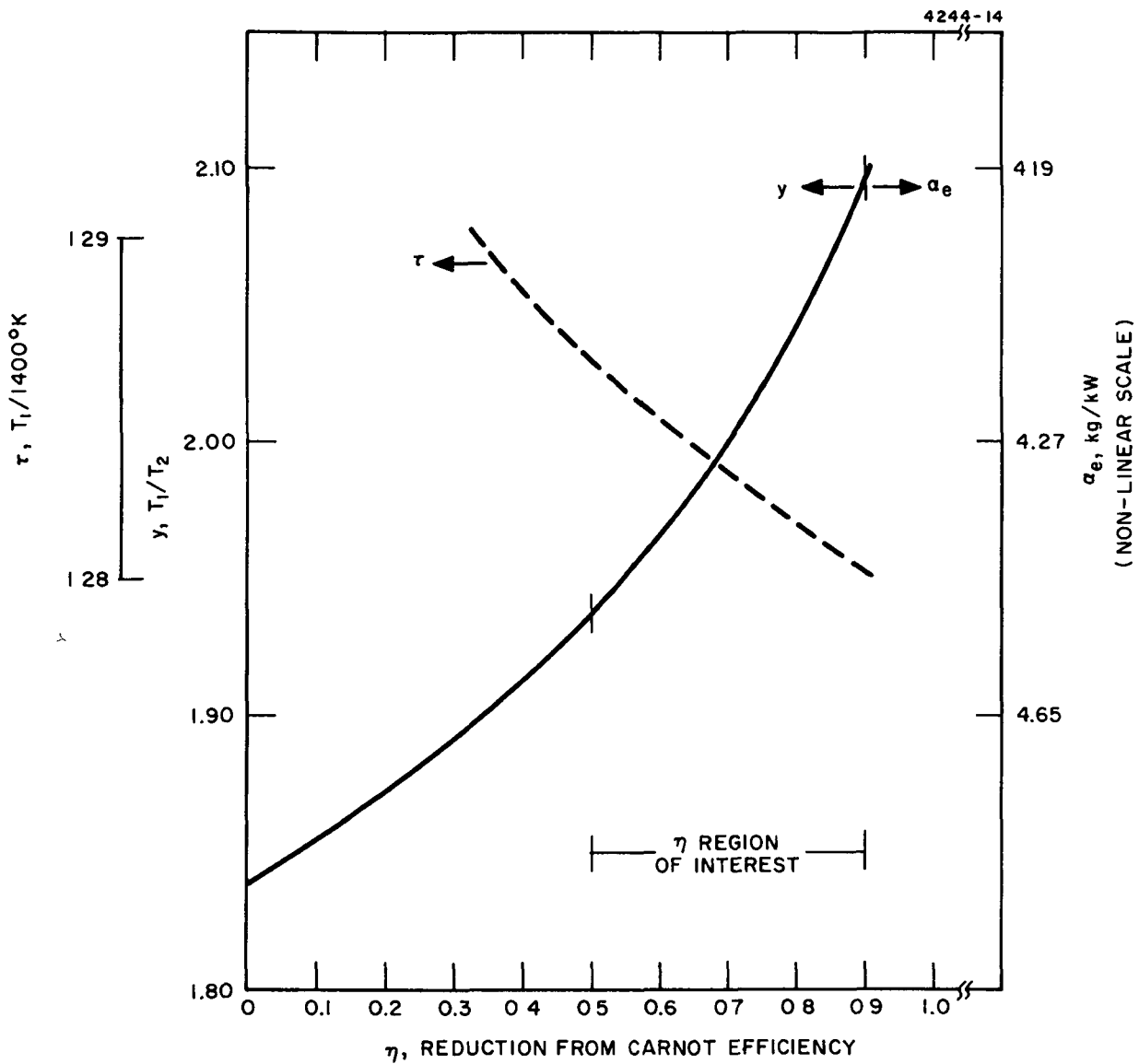

Fig. G-3. Optimization of LEP thermal cycle system with Ehrlicke Sphere.