

CORRELATION WITH FLIGHT OF SOME AEROELASTIC MODEL STUDIES IN THE  
NASA LANGLEY TRANSONIC DYNAMICS TUNNEL\*

Wilmer H. Reed III

NASA Langley Research Center

SUMMARY

The NASA Langley transonic dynamics tunnel, which has a variable density Freon-12 (or air) test medium, was designed specifically for the study of dynamics and aeroelastic problems of aerospace vehicles. During the 15 years of operation of this facility, there have been various opportunities to compare wind-tunnel and flight-test results. Some of these opportunities arise from routine flight checks of the prototype; others, from carefully designed comparative wind-tunnel and flight experiments. This paper brings together in one place a collection of such data obtained from various published and unpublished sources. The topics covered are: gust and buffet response, control surface effectiveness, flutter, and active control of aeroelastic effects. Some benefits and shortcomings of Freon-12 as a test medium are also discussed. Although areas of uncertainty are evident and there is a continuing need for improvements in model simulation and testing techniques, the results presented herein indicate that predictions from aeroelastic model tests are, in general, substantiated by full-scale flight tests.

INTRODUCTION

At the time the forerunner of this symposium (Symposium on Flight Flutter Testing held in Washington, D.C., May 1958) was held 17 years ago, a new transonic wind tunnel was nearing completion at NASA Langley Research Center. Designated the Langley transonic dynamics tunnel (TDT), it has served, since becoming operational in 1960, as a National facility devoted exclusively to work on dynamics and aeroelasticity problems of aircraft and space vehicles in the transonic speed range.

An essential difference between the TDT and wind tunnels employed primarily in steady-state aerodynamic investigations stems from the scaling requirements which must be satisfied in aeroelastic model studies. For example, in addition to the need for adequate simulation of the aerodynamic flow field about the model, it is also necessary that the model stiffness, mass, and inertia properties simulate those of the full-scale structure and that the ratio of structural

---

\*This paper is essentially the same as a presentation entitled "Comparison of Flight Measurements With Predictions From Aeroelastic Models in the NASA Langley Transonic Dynamics Tunnel," by Wilmer H. Reed III, presented at the 46th AGARD Flight Mechanics Panel Symposium on Flight/Ground Facility Correlation, Valloire, France, June 9-12, 1975.

density to test-medium density be the same for model and full scale. To aid in satisfying these requirements, the TDT uses a variable-density test medium of either air or Freon-12. The primary test medium, Freon-12, is four times as dense as air and has a speed of sound about one-half that of air; thus heavier and less expensive models may be used and the tunnel power requirements reduced. Some main features of the facility are indicated in figure 1.

Experimental aeroelastic research also imposes demanding requirements for specialized testing techniques. A review of such testing techniques developed by the staff of the Langley transonic dynamics tunnel for use in studies of various stability, control, and response characteristics of elastic aircraft is given in reference 1.

From time to time during the 15-year period of operation of this facility, there have been various opportunities to compare the results from wind-tunnel and flight tests. Some of these opportunities arise from routine flight checks of the prototype, others from carefully designed comparative wind-tunnel and flight experiments. This paper brings together in one place a collection of such data, gleaned from various published and unpublished sources, for the purpose of addressing the question: How well can dynamically scaled aeroelastic models, tested in a Freon-12 wind-tunnel environment, predict the behavior of their full-scale counterparts in flight? To this end, some advantages and shortcomings of Freon-12 as a wind-tunnel test medium are considered and then selected comparisons between wind-tunnel and flight tests in areas relating to dynamic response, static aeroelasticity, flutter, and active-controls research are presented.

#### AIR-FREON COMPARISONS

Before comparing test results obtained in the Langley transonic dynamics tunnel with flight data, a few comments are in order on air-Freon data comparisons since, by far, most of the tests conducted in this facility make use of a Freon-12 test medium. (Air can also be used as a test medium.) Freon-12 has several characteristics which make it a very attractive test medium for scaled dynamic model studies. Some of the more important properties at atmospheric pressure and temperature are compared with those of air in table I. The most advantageous characteristics are the high density and low speed of sound of Freon-12 relative to air at the same pressure and temperature. The relatively low speed of sound is significant for several reasons. For dynamic model tests in which the reduced-frequency scaling parameter  $\omega b/V$  must be satisfied, the lower tunnel speed for a given Mach number reduces directly all pertinent frequencies and, consequently, simplifies instrumentation problems and reduces inertia loads. For tests involving rotating helicopter blades where model and full-scale tip Mach numbers must be the same, the stresses and hence the difficulties of fabrication are reduced. For flutter and other dynamic tests, where the ratio of structural-density to test-medium density must be the same for the model as the airplane, the more dense Freon-12 permits heavier models to be constructed. This is a distinct advantage when the difficulty of fabricating models light enough to simulate the mass characteristics of aircraft designs with composite structures and active controls operating at high speeds

and low altitudes is considered. The use of Freon-12 as a test medium allows the simultaneous satisfaction of both Mach number and Froude number for those instances where both compressibility and gravitational effects must be scaled. For Froude number similarity, an approximately 1/5-scale model is required. An additional benefit is that, for a given model size, test conditions of equal Mach number and stagnation pressure produce a Reynolds number in Freon-12 approximately three times that in air. Finally, since the power required to operate a wind tunnel at a given Mach number varies directly as the cube of the velocity, the use of Freon-12 offers a considerable savings in power.

The principal uncertainty associated with the use of Freon-12 as a test medium is the fact that its specific heat ratio  $\gamma$  is not the same as that for air (1.13 as compared with 1.4), so that quantitative differences exist between the compressibility relations for air and Freon. There have been numerous studies of the degree to which data obtained from tests in Freon-12 can be utilized to predict flow characteristics, structural response, or stability in air (refs. 2 to 5). For example, in references 2 and 3, the significance of this difference in gas characteristics on static aerodynamic coefficients was studied extensively, and means for converting Freon-12 data to equivalent air values were evaluated. These studies indicated that at subsonic and low supersonic Mach numbers the required corrections were small and that the difference between the converted results by two correction methods, the "transonic similarity rule" and the "streamline similarity rule," were very small. Reference 5 reports the results of an experimental subsonic and transonic flutter investigation of a 45° sweptback wing planform that was tested in air and in Freon-12 in the TDT. Comparisons of data in air and in Freon-12 indicated that for subsonic and transonic Mach numbers, the flutter speed obtained in Freon-12 may be interpreted directly as flutter speed in air at the same mass ratio and Mach number. Without the Freon-12 and air corrections, the Freon-12 data would result in a slightly conservative estimate of the flutter speed.

Although one might infer from these flutter data comparisons that the effect of different ratios of specific heat for air and Freon-12 are insignificant for unsteady aerodynamic forces up to low supersonic speeds, the effect on detailed unsteady pressure distributions has only recently been demonstrated analytically. Figure 2 presents some results of a finite-difference calculation of the pressure distribution on an NACA 64A006 airfoil in air and in Freon-12. The airfoil is oscillating in pitch about the midchord at a low reduced frequency ( $k = 0.06$ ); the Mach number is 0.9. Small oscillations about a nonuniform mean flow field were considered in the calculation which yields a linear potential flow equation with variable coefficients that depend on the steady flow field. (See ref. 6.) The static pressure coefficient  $C_p$  and the amplitude and phase angle of the oscillating pressure,  $|\Delta C_p|$  and  $\phi$ , respectively, are shown in figure 2 as a function of chordwise location. The rapid change in the steady pressure coefficient  $C_p$  near the 65-percent chord location indicates a shock. The principal difference between the Freon-12 and air data is seen to be the locations of the peak unsteady pressures  $|\Delta C_p|$  and the values of the phase angle  $\phi$  in the vicinity of the shock. Inasmuch as shock waves and related transonic effects tend to be less severe for three-dimensional than for two-dimensional flow, the effects of  $\gamma$  on three-dimensional configurations may be correspondingly milder than those indicated here. Additional study is needed to further evaluate these effects in unsteady flow.

An experimental study that will partially fulfill this need is planned for the near future. The study will involve the measurement of unsteady pressure distributions on a cropped-tip delta wing oscillating in a pitching and a flapping mode in air and in Freon-12 at comparable Reynolds numbers through the transonic speed range. The model will also have oscillating leading- and trailing-edge control surfaces. This study should provide needed experimental data for evaluating advanced transonic unsteady aerodynamic theories and for evaluating the unsteady flow characteristics of air and Freon-12.

## WIND-TUNNEL AND FLIGHT COMPARISONS

This section of the paper presents selected examples showing comparisons of results obtained in the TDT and in flight tests. In all cases Freon-12 was used as a test medium, and the models were dynamically and aeroelastically scaled to suitably match full-scale conditions. The following topics are covered herein:

- (1) Gust response
- (2) Buffet response
- (3) Stability derivative extraction
- (4) Flutter
- (5) Active control of aeroelastic effects

### Gust Response

The response of an aircraft to atmospheric turbulence is an important design consideration from the standpoint of loads, structural fatigue, and ride quality. The need for an experimental capability for the study of airplane response to gust loads led to the development of a technique for generating sinusoidal gusts in the test section of the TDT. This technique, described in reference 7, involves measuring the response of an aeroelastically scaled model in simulated free flight to a sinusoidal vertical gust field generated by oscillating vanes located upstream of the test section.

Some key features of the system are illustrated in figure 3. The model is suspended in the wind-tunnel test section by a two-cable mount system, which allows lateral and vertical translation of the model as well as angular rotation about all three axes. (See ref. 8.)

The airstream oscillator consists of two sets of biplane vanes mounted on each side of the test-section entrance. The vanes are oscillated sinusoidally in pitch about a zero mean angle of attack at frequencies up to 20 hertz. Trailing vortices from the vane tips, passing downstream near the sidewalls of the test section, induce a vertical-velocity component in the flow field near the center of the test section.

A typical variation of the vertical gust flow angle with frequency and lateral distance from the center of the test section is shown in figure 4 in

the form of a three-dimensional plot. Note that the gust angle decreases rapidly with increasing frequency, and there are variations in the flow angle across the tunnel.

Initial analytical and experimental studies in references 1 and 7 indicated the feasibility of the airstream oscillator technique. On the basis of these encouraging signs, a comparative wind-tunnel, flight, and analysis study was undertaken in late 1960 that used the B-52E aircraft as the test article.

The wind-tunnel program involved a 1/30-size dynamically scaled aeroelastic model of the B-52E. (See fig. 5.) In order to achieve reasonable simulation of the short-period mode on the model, it was necessary to use a variation of the two-cable mount system shown in figure 3. In this case, the cables were pinned to the model at a point near the center of gravity and the pulleys were mounted at the tunnel wall rather than within the contours of the model fuselage. This mount configuration has a very low rotational stiffness in pitch and provides adequate simulation of the short-period free-flight mode.

Figure 6 shows a sample of some unpublished results obtained by L. T. Redd and J. Gilman, Jr., of NASA Langley Research Center. Frequency response plots of a nondimensional coefficient of bending moment at the midwing span per degree of sinusoidal vertical gust angle are shown for three cases: (1) wind-tunnel-model tests using the airstream oscillator, (2) analytical predictions for the cable-mounted model, and (3) flight tests using spectral measurements of atmospheric turbulence and the associated response of the airplane. These data were produced with the aid of The Boeing Company, Wichita Division, under contract in a cooperative program by NASA Langley Research Center and the U.S. Air Force Flight Dynamics Laboratory.

With reference to figure 6, it should be noted that at very low reduced frequencies ( $k = 0.01$ , where  $k$  is the reduced frequency based on the mean aerodynamic semichord), the model response is affected by a mount system mode and the airplane response by spurious pilot-induced motions; at higher reduced frequencies ( $k = 0.14$ ), the low gust input level produced by the airstream oscillator (see fig. 4) leads to measurement inaccuracies. The overall correlations between wind-tunnel, flight, and analytical predictions appear to be good, however, and indicate the airstream oscillator to be a useful and valid wind-tunnel technique for airplane gust loads research. (In the oral version of the paper a movie clip was used to illustrate gust response of the model and the airplane.)

#### Buffet Response

When buffet response and load predictions of complete aircraft are required, a dynamically scaled aeroelastic model test would seem to offer the best hopes of obtaining suitable data. Since viscous flow phenomena, including boundary-layer separation, are influenced in varying degrees by the value of the Reynolds number, this parameter would appear to be somewhat more significant for buffet studies than for flutter tests. Although the locations of local shocks and commencement of local separated flow may be Reynolds number dependent in varying degrees, depending on the particular aerodynamic configuration, there is some

experimental evidence to suggest that the integrated effects on the structural response and even on total lift may be small relative to other factors affecting the accuracy of buffet loads. The aeroelastic model approach for predicting buffet loads has been evaluated in reference 9 by comparing the normal-force coefficients and the scaled buffet bending moments and accelerations measured on a 1/8-scale flutter model of a variable-sweep fighter airplane with those measured in a flight-buffet-research program. (See ref. 10.) The model was "flown" on the basic cable-mount system described earlier with a lift balancing device (see fig. 3 and ref. 9) which counteracted the lift in excess of the model weight and thus allowed the model to be flown under conditions simulating high load factors (inertia and pitch-rate effects being neglected, of course).

Figure 7 compares the model and full-scale variation of normal-force coefficient  $C_N$  with angle of attack well beyond the buffet boundary for three angles of sweep. The model  $C_N$  was obtained from a load cell on the lift balancing cable, whereas the airplane  $C_N$  was obtained from an accelerometer located near the center of gravity. The model Reynolds number range was from  $0.87 \times 10^6$  to  $1.33 \times 10^6$  compared with flight values of  $20 \times 10^6$  to  $28 \times 10^6$ . The Mach numbers indicated are model values. The airplane Mach number varied from slightly above the model value of the start of the maneuver to slightly below the model value at the end of the maneuver (high angle of attack). The variance was larger at the higher sweep angles. The model and airplane values of  $C_N$  are seen to agree reasonably well.

Figure 8 compares the airplane buffet response with model-predicted values of wing and horizontal-tail root-mean-square (rms) bending moments and rms accelerations at the center of gravity. The data are typical in that the full-scale-buffet bending moments on the wing and horizontal tails and the center-of-gravity buffet accelerations predicted from the model data agreed well with airplane values at all Mach numbers at a wing sweep angle of  $26^\circ$ . Although not shown here, at a wing sweep angle of  $50^\circ$  the agreement was reasonably good at all Mach numbers tested for the wing bending moments, but the correlation of the model and airplane center-of-gravity accelerations and horizontal-tail bending moments was not so good at the higher Mach numbers. At  $72^\circ$  sweep, both the airplane and model response were low and made evaluation of the technique difficult.

#### Stability Derivative Extraction From Cable-Mounted Wind-Tunnel Model Tests

Procedures for determining airplane stability and control derivatives from flight-test measurements have been under development since the early days of aviation. In recent years, however, a widespread surge of interest in this area has been triggered by the availability of highly automated data acquisition systems and advances in optimal estimation theory. The current status and prospects for the future of this technology were topics of a recent specialist meeting on methods of parameter identification in aircraft flight testing. (See ref. 11.)

Paralleling this focus on flight-testing techniques is an interest in applying similar procedures for the extraction of stability and control

derivatives from "free-flying" aeroelastically scaled wind-tunnel models. Preliminary indications from theoretical studies and companion wind-tunnel experiments are encouraging. The proposed procedure involves measuring the response of a cable-mounted model to known input disturbances such as control-surface deflections or external forces applied through the suspension cables. The stability derivatives are then extracted from equations of motion for the model and the suspension system using a maximum-likelihood parameter-estimation algorithm (based on ref. 12) which is being developed under contract by NASA Langley Research Center. The equations of motion represent five degrees of freedom (pitch, roll, yaw, vertical translation, and lateral translation) wherein the model is treated as an equivalent rigid body. The derived aerodynamic derivatives therefore represent quasi-static elastic derivatives. Deformation effects associated with gravity forces are neglected. However, by use of the lift balance mentioned earlier, high-angle-of-attack nonlinear aerodynamic coefficients may be determined.

The procedures described above are, in theory, capable of deducing the aerodynamic coefficients associated with whatever motions of the model are excited by the known external disturbances. Numerical experiments using simulated "noisy" wind-tunnel data show promise that most aerodynamic derivatives can be determined with acceptable accuracy. Further assessment of the method will be made in upcoming wind-tunnel model tests. In a previous study a simplified version of such a technique was applied to determine roll-control effectiveness for a cable-mounted aeroelastic model (refs. 1 and 13). The technique and some comparisons between wind-tunnel and flight results are summarized below.

The approach is based on the assumption that the dynamic response of a cable-mounted model to sinusoidal aileron deflection can be represented by a single-degree-of-freedom system in roll. The roll inertia of the model, the spring restraint of the mount system, and the wind-tunnel test conditions are assumed to be known; the roll damping coefficient  $C_{l_p}$  and aileron effectiveness coefficient  $C_{l_\delta}$  are the unknowns to be determined. The amplitude and phase of the model-roll response to a sinusoidal aileron deflection are measured over a range of discrete frequencies. These measurements, when substituted into the equation of motion, produce a set of redundant algebraic equations which are solved by a least-squares procedure to give the unknown aerodynamics derivatives  $C_{l_p}$  and  $C_{l_\delta}$ . The ratio of these coefficients is proportional to the free-flight control effectiveness which is normally expressed in terms of the wing-tip helix angle,  $pb/2V$ ; where  $p$  is roll rate;  $b$ , wing span; and  $V$ , airspeed.

A comparison of the aileron effectiveness measured in flight with wind-tunnel model prediction is shown in figure 9. These results are for a large cargo transport aircraft at a Mach number of 0.75. The model data were obtained on a Mach scaled aeroelastic model used previously in flutter studies. Since the ailerons become ineffective as the aileron reversal point is approached, roll trim of the model was provided mechanically by differential deflection of the horizontal rear cables as shown in figure 3. The model and flight comparisons shown in figure 9 indicate that this relatively simple test technique can

provide satisfactory estimates of not only the reversal boundaries, but also the aileron effectiveness of the airplane as a function of Mach number and dynamic pressure.

### Flutter

During high-altitude flight tests of a large cargo transport airplane, a flutter-type instability was encountered on the horizontal-tail surface of the T-tail empennage. The instability occurred at a Mach number near 0.8 but only during maneuvering flight when the elevator was deflected more than about  $8^\circ$  in either direction. The problem was characterized by a limited amplitude oscillation involving coupling between elevator rotation and stabilizer torsion at a frequency of about 24 hertz. (Since the phenomenon had the earmarks of two types of control surface instabilities, flutter and buzz, it has been referred to as "fluzz.") Prior to the incident, flight flutter tests and analyses, which were for small elevator deflections, indicated no flutter problems within the airplane's operating envelope. Subsequent flight investigations of various proposed solutions, such as vortex generators, dampers, and elevator mass balance, led to the selection of increased elevator mass balance as the most promising solution. (See ref. 14.)

Because there was little or no information available in the literature at the time on instabilities initiated by large control surface deflections, an experimental study was undertaken in the TDT to explore the phenomenon further. (See ref. 15.) Results from the study are summarized in figure 10. It was found that the basic instability phenomenon encountered on the airplane in flight tests was reproduced in the wind tunnel although at higher predicted speeds. Whereas in flight, the instability occurred when the elevator deflection exceeded  $8^\circ$  in either direction, it occurred in the wind tunnel only when the deflection exceeded  $8^\circ$  in one direction, that is, trailing edge down. The reason for this behavior may have been due to increased bearing friction in the model elevator associated with bending of the tail under static loads. Finally, it should be noted that the elevator mass balancing used as a solution to the airplane flutter problem also eliminated flutter on the model.

### Active Control of Aeroelastic Effects

Active control system technology today is adding a new dimension to airplane design. Through application of active control concepts, or what has become known as CCV (Control Configured Vehicles), the designer can reap such benefits as weight savings, performance improvements, and better ride quality. Four such applications and associated potential benefits are (1) reduced static stability leading to decreased drag and smaller tail size, (2) gust and maneuver load alleviation leading to increased fatigue life and/or structural weight savings, (3) ride quality control leading to improved crew and passenger comfort, and (4) flutter suppression leading to weight savings or increased flutter placard speeds. All the above have been demonstrated by analysis, wind-tunnel tests, and flight tests. (See refs. 16 and 17.) Wind-tunnel and flight comparisons for two such applications — flutter suppression and load alleviation — are discussed in the remaining sections of the paper.



Active flutter suppression.- To demonstrate the feasibility of various active control concepts, the U.S. Air Force Flight Dynamics Laboratory initiated a flight program with The Boeing Company, Wichita Division, to study Control Configured Vehicle concepts using the B-52E airplane. (See ref. 18.) Included in the concepts studied by analyses and flight tests was active flutter suppression or, in other words, flutter mode control. In parallel with the CCV flight program, a companion wind-tunnel-model research program was undertaken jointly by NASA and the USAF with contract support by Boeing (Wichita). (See ref. 19.) The 1/30-size dynamically scaled aeroelastic model of the B-52E, used previously in gust research (fig. 5), was modified to simulate the active control systems of the CCV research airplane. Because of the increased weight associated with the miniature electromechanical control system added to the model, the model could not simulate the mass scaling factor for the nominal-weight CCV airplane. Therefore, for the purpose of comparing wind-tunnel and flight results special heavyweight airplane conditions were flown which required in-flight refueling. Thus, the airplane was altered to match the wind-tunnel model.

The wing-flutter mode control on the model, like the airplane, involved flaperons and outboard ailerons. Vibratory motions of the wing were sensed by accelerometers. These signals were sent from the model to a remotely located, general-purpose analog computer on which the control laws were simulated and then back again to the model as control surface command signals. Some sample results from this study (taken from ref. 19) are presented in figure 11 which shows the effect of the flutter mode control system on the subcritical damping measured in the wind tunnel and in flight. Note that the flutter speed of the model is within 8 percent of the flutter speed of the airplane; damping trends below the flutter speed are similar but the damping of the model is higher than for the airplane. In view of the high degree of complexity involved in the wind-tunnel model simulation, this agreement is considered to be very good. In fact, the wind-tunnel model results agree more closely with flight-test data than calculations do (not shown).

This flight validation of wind-tunnel modeling of active control systems thus tends to establish the technique as an economical, timely means of verifying the performance of Control Configured Vehicles of the future.

Active load alleviation.- Another application of active controls has been developed for the C-5A airplane as a means of reducing wing fatigue damage due to incremental maneuver and gust-load sources. This system, designated the active lift distribution control system (ALDCS), is described in detail in reference 20. Basically, the ALDCS uses accelerometers located in the outer wing to provide control surface command signals, through the airplane stability augmentation system, to servo actuators on the ailerons and elevators. The ailerons are deflected to redistribute the air loads on the wing so as to reduce inboard-wing stresses whereas the elevators are deflected to maintain trim. Specific design goals for the system are to reduce the incremental wing root bending moment by 30 percent without significantly affecting the performance, flutter margins, or handling qualities of the C-5A.

As part of the ALDCS development program, a wind-tunnel study of a 1/22-size dynamically scaled aeroelastic model equipped with proposed active control system was undertaken in the Langley transonic dynamics tunnel. The purpose of

this program, which was a joint effort of the U.S. Air Force, Lockheed Georgia Company, and the Langley Research Center was to gain added confidence in the ALDCS and to evaluate its possible effect on flutter before undergoing flight tests. The model is shown in figure 12. Unlike the active control system on the B-52 model described earlier, the C-5A model control system was powered by an onboard hydraulic system. The dynamic response characteristics (gain and phase lag) of this system matched those of the airplane up to frequencies of 35 hertz on the model.

The wind-tunnel model program included a number of facets, one being to evaluate the effectiveness of the ALDCS by measuring the wing bending-moment response to sinusoidal aileron frequency sweeps. Similar measurements were obtained in flight for comparable conditions. Some typical results from wind-tunnel and flight tests are presented in figure 13. This figure shows the variation with aileron frequency of the wing-root bending moment normalized to the maximum bending moment with ALDCS off which occurs at about 1 hertz, the wing fundamental bending frequency. The overall trends for the airplane and the model are similar; however, the airplane system is apparently more effective than was predicted by the model. The cause of this difference could be associated with the fact that the aileron control effectiveness measured statically on the model was only about two-thirds of that measured on the airplane. (The ailerons were sealed on the airplane but not on the model.)

A second difference to be noted is the peak on the model response at approximately 1/2 hertz (scaled to airplane) with the ALDCS on. This is believed to be due to coupling between the active control system and the model mount system. Similar coupling effects have been observed in test of the B-52 model with a simulated active-ride-control system. Here, the feedback gains of the ride-control system had to be reduced in order to avoid an instability arising from the control system coupling with mount system modes. Thus, improvements in model mount systems are needed to permit more accurate simulation of the active control systems designed to modify the airplane rigid-body dynamics.

(In the oral version of the paper a movie clip was used to show some effects of active controls on aeroelastic response of the B-52 and C-5A in flight and of models in the wind tunnel.)

#### CONCLUDING REMARKS

This paper has attempted to assess the validity of predictions obtained from dynamically scaled aeroelastic models in the Langley transonic dynamics tunnel that uses Freon-12 as a test medium. To this end wind-tunnel and flight-test results pertaining to various aeroelastic problem areas were brought together in one place for comparative evaluations. These areas include gust and buffet response, control surface effectiveness, flutter and active control of aeroelastic effects. Some benefits and shortcomings of Freon-12 as a test medium were also discussed.

Although some uncertainties remain, and there is the continuing need for improvements in simulation and testing techniques, the results presented herein indicate that the predictions from wind-tunnel studies are, in general, substantiated by full-scale flight measurements. During the 15-year period since the Langley transonic dynamics tunnel was put into operation, aeroelastic studies in this facility have provided a highly effective means of gaining insight into new phenomena, verifying analytical methods, and establishing flight safety — especially in the important transonic range where present analytical methods are usually inadequate.

Finally, it should be noted that with the existing capabilities of the Langley transonic dynamics tunnel, it is often difficult to fabricate models light enough to satisfy mass-scaling requirements for current aircraft designs. For future designs, embodying composite structures and active control systems, this difficulty is likely to be compounded many fold. To alleviate these emerging problems, planning is underway to increase, by 50 percent, the maximum power and thus the maximum stagnation pressure of the Langley transonic dynamics tunnel.

## REFERENCES

1. Rainey, A. Gerald; and Abel, Irving: Wind-Tunnel Techniques for the Study of Aeroelastic Effects on Aircraft Stability, Control, and Loads. Aeroelastic Effects From a Flight Mechanics Standpoint, AGARD CP No. 46, Apr. 1969.
2. Von Doenhoff, Albert E.; Braslow, Albert L.; and Schwartzberg, Milton A.: Studies of the Use of Freon-12 as a Wind-Tunnel Testing Medium. NACA TN 3000, 1953.
3. Pozniak, O. M.: Investigation Into the Use of Freon 12 as a Working Medium in a High-Speed Wind-Tunnel. Note No. 72, Coll. Aeronaut., Cransfield (Engl.), Nov. 1957.
4. Treon, Stuart L.; Hofstetter, William R.; and Abbott, Frank T., Jr.: On the Use of Freon-12 for Increasing Reynolds Number in Wind-Tunnel Testing of Three-Dimensional Aircraft Models at Subcritical and Supercritical Mach Numbers. Facilities and Techniques for Aerodynamic Testing at Transonic Speeds and High Reynolds Number, AGARD CP No. 83, Aug. 1971, pp. 27-1 - 27-8.
5. Yates, E. Carson, Jr.; Land, Norman S.; and Foughner, Jerome T.: Measured and Calculated Subsonic and Transonic Flutter Characteristics of a 45° Sweptback Wing Planform in Air and in Freon-12 in the Langley Transonic Dynamics Tunnel. NASA TN D-1616, 1963.
6. Ehlers, F. Edward: A Finite Difference Method for the Solution of the Transonic Flow Around Harmonically Oscillating Wings. NASA CR-2257, 1974.
7. Gilman, Jean, Jr.; and Bennett, Robert M.: A Wind-Tunnel Technique for Measuring Frequency-Response Functions for Gust Load Analyses. J. Aircraft, vol. 3, no. 6, Nov.-Dec. 1966, pp. 535-540.
8. Reed, Wilmer H., III; and Abbott, Frank T., Jr.: A New "Free-Flight" Mount System for High-Speed Wind-Tunnel Flutter Models. Proceedings of Symposium on Aeroelastic & Dynamic Modeling Technology, RTD-TDR-63-4197, Pt. 1, U.S. Air Force, Mar. 1964, pp. 169-206.
9. Hanson, Perry W.: The Prediction of Structural Response to Buffet Flow: A State-of-the-Art Review. 39th AGARD Structural and Materials Meeting (Munich, Germany), Oct. 1974. (Available as NASA TM X-72627.)
10. Friend, Edward L.; and Monaghan, Richard C.: Flight Measurements of Buffet Characteristics of the F-111A Variable-Sweep Airplane. NASA TM X-1876, 1969.
11. Methods for Aircraft State and Parameter Identification. AGARD CP-172, Nov. 1974.

12. Mehra, Raman K.; Stepner, David E.; and Tyler, James S.: Maximum Likelihood Identification of Aircraft Stability and Control Derivatives. J. Aircraft, vol. 11, no. 2, Feb. 1974, pp. 81-89.
13. Abel, Irving: Evaluation of a Technique for Determining Airplane Aileron Effectiveness and Roll Rate by Using an Aeroelastically Scaled Model. NASA TN D-5538, 1969.
14. McAvoy, J. M.: C-141A Empennage Flutter Substantiation With Revised Elevator Balance Weights. Rep. No. ER-8471, Lockheed Georgia Co., June 15, 1966.
15. Sandford, Maynard C.; and Ruhlin, Charles L.: Wind-Tunnel Study of Deflected-Elevator Flutter Encountered on a T-Tail Airplane. NASA TN D-5024, 1969.
16. Holloway, R. B.: Introduction of CCV Technology Into Airplane Design. Aircraft Design Integration and Optimization, AGARD CP-147, vol. 1, Oct. 1973.
17. Doggett, Robert V., Jr.; Abel, Irving; and Ruhlin, Charles L.: Some Experiences Using Wind-Tunnel Models in Active Control Studies. Advanced Control Technology and Its Potential for Future Transport Aircraft, NASA TM X-70240, 1974.
18. Thompson, Glenn O.; and Arnold, James I.: B-52 Controls Configured Vehicle System Design. AIAA Paper No. 72-869, Aug. 1972.
19. Redd, L. T.; Gilman, J., Jr.; Cooley, D. E.; and Severt, F. D.: Wind-Tunnel Investigation of a B-52 Model Flutter Suppression System. J. Aircraft, vol. 11, no. 11, Nov. 1974, pp. 659-663.
20. Grosser, W. F.; Hollenbeck, W. W.; and Eckholdt, D. C.: The C-5A Active Lift Distribution Control System. Impact of Active Control Technology on Airplane Design, AGARD CP-157, Oct. 1974.

TABLE I. COMPARISON OF SELECTED AIR AND FREON-12 PROPERTIES

AT ATMOSPHERIC PRESSURE AND TEMPERATURE

Property	Freon-12	Air	Freon-12/air
Specific heat, $\gamma$	1.13	1.4	0.807
Density, $\rho$ , kg/m <sup>3</sup>	4.896	1.226	3.99
Speed of sound, $a$ , m/sec	152	341	0.446
Viscosity, $\mu$ , N-sec/m <sup>2</sup>	12.81 x 10 <sup>-6</sup>	18.1 x 10 <sup>-6</sup>	0.708

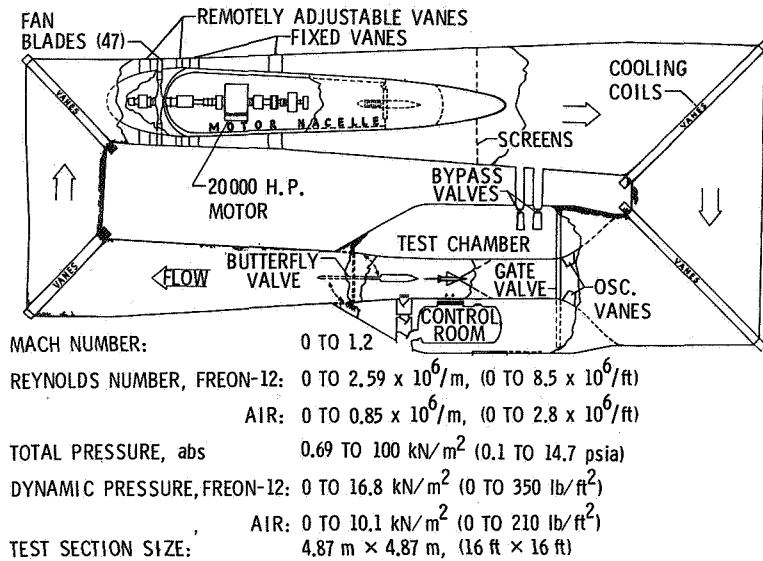

Figure 1.- NASA Langley transonic dynamics tunnel.

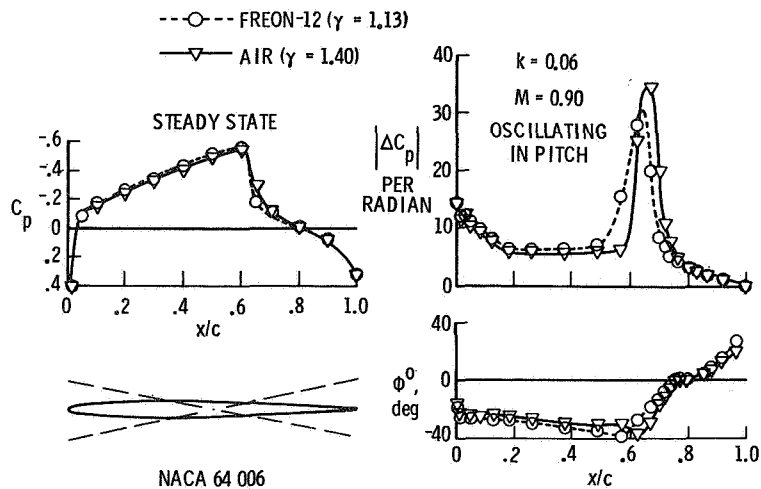

Figure 2.- Calculated pressure distributions for oscillating airfoil in air and in Freon-12.

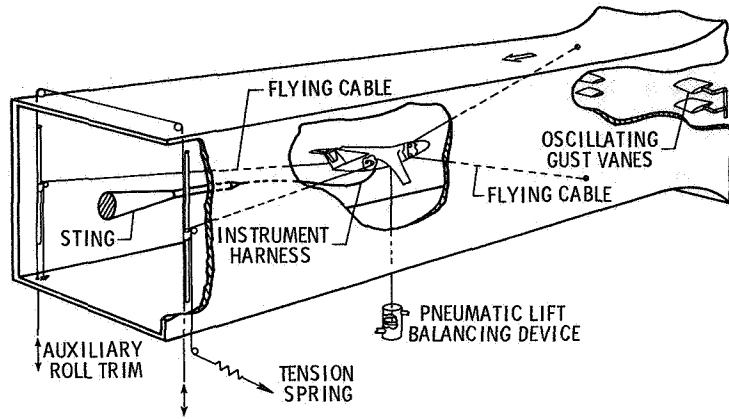

Figure 3.- Some aeroelastic model testing features in the Langley transonic dynamics tunnel.

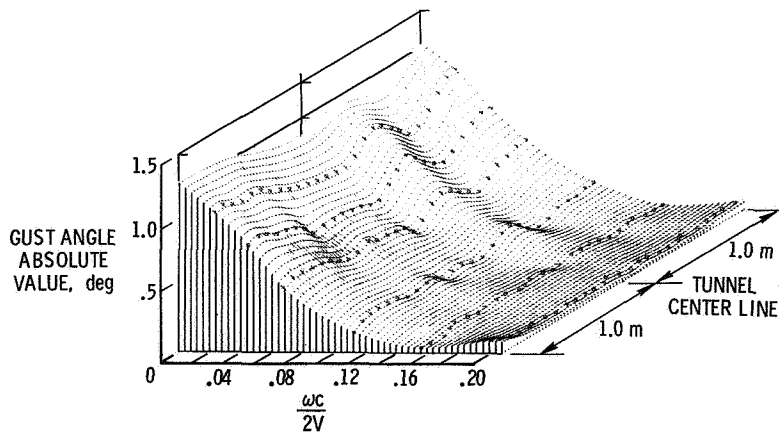

Figure 4.- Typical variation of gust flow angle with reduced frequency and lateral position for  $\pm 6^\circ$  oscillating vane angle. ( $V = 35.4$  m/sec and  $c = 0.233$  m.)

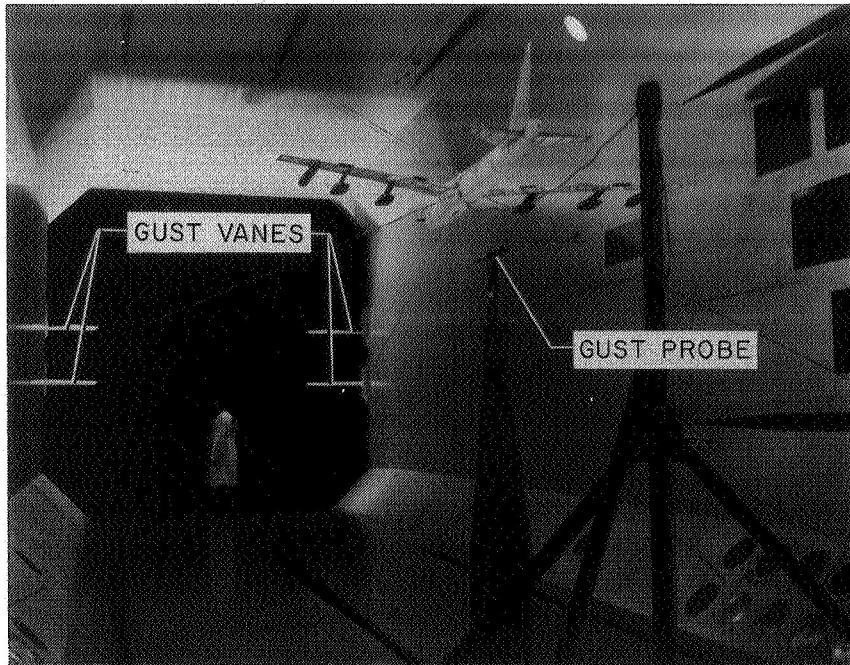

Figure 5.- View of B-52 aeroelastic model showing gust-generating vanes.

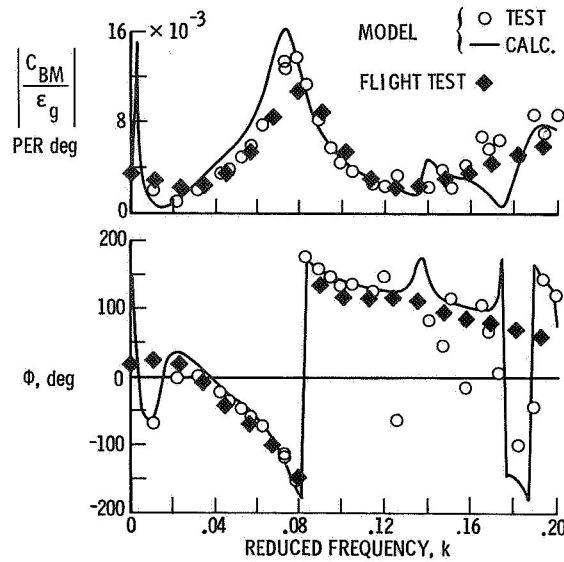

Figure 6.- Frequency response of B-52 from flight tests and wind-tunnel model tests using gust-generating vanes.



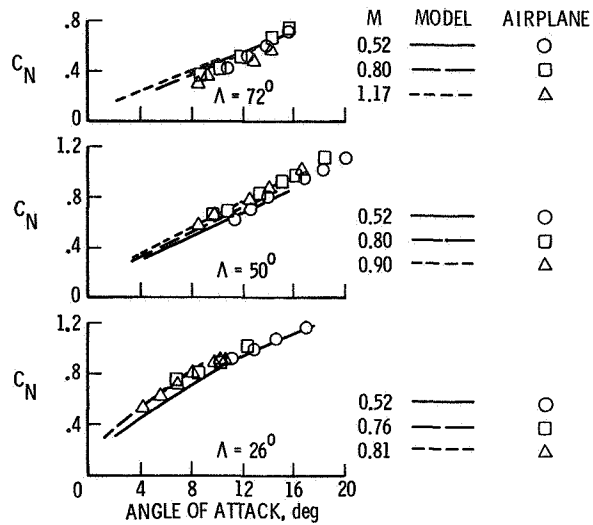

Figure 7.- Comparison of model and airplane  $C_N$  variation with angle of attack (ref. 9).

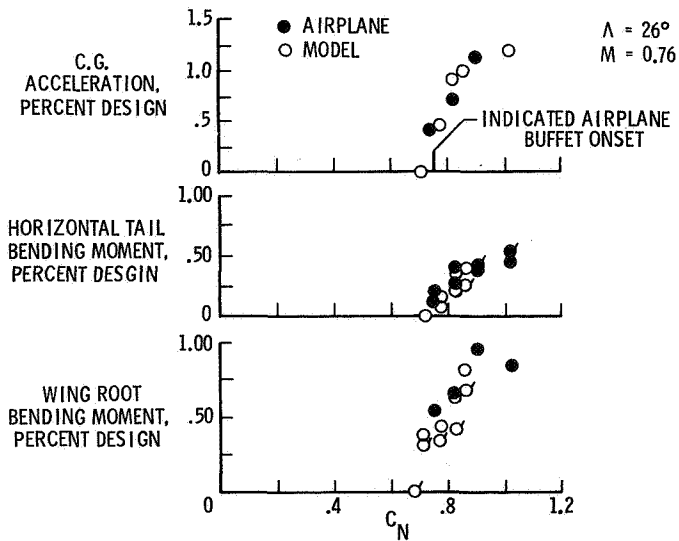

Figure 8.- Comparison of buffet response from airplane and model tests normalized to airplane design loads.  $M = 0.76$ ;  $26^\circ$  wing sweep (ref. 9).

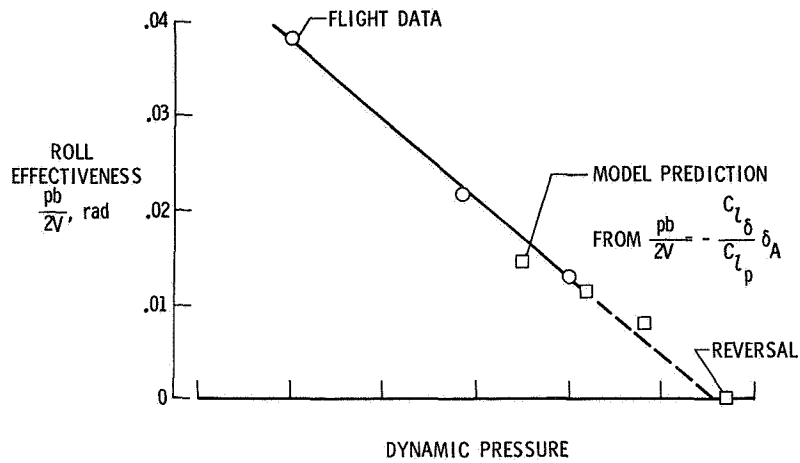

Figure 9.- Comparison of flight measurements and model-predicted aileron effectiveness (ref. 1).

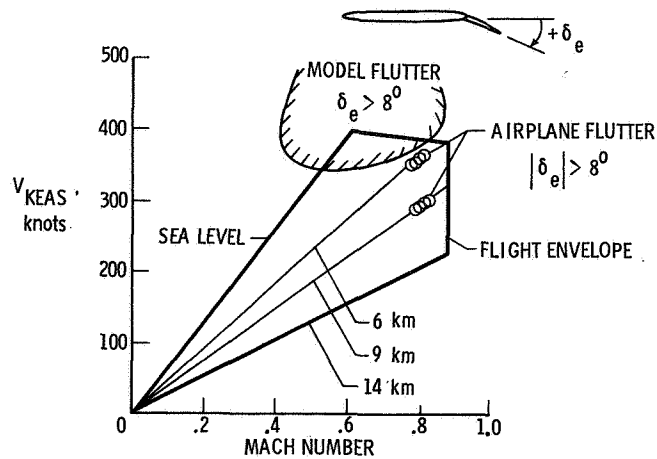

Figure 10.- Comparison of flight measurements and model-predicted flutter of T-tail with deflected elevator (ref. 15).

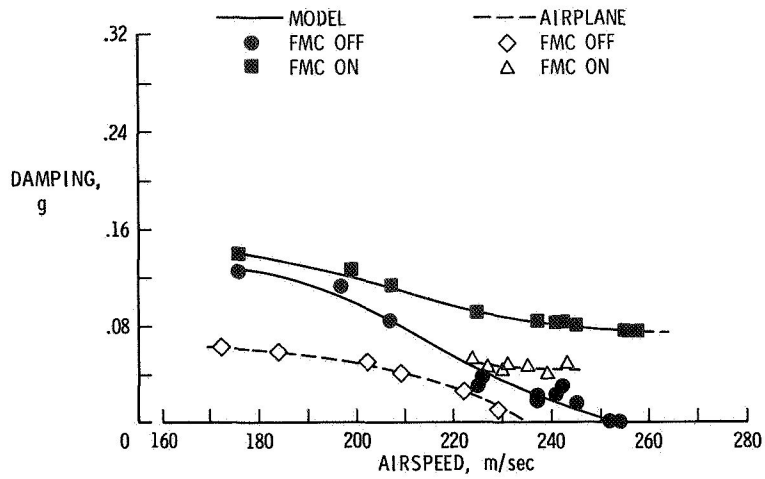

Figure 11.- Effect of flutter mode control system on damping of B-52 CCV model and airplane (ref. 19).

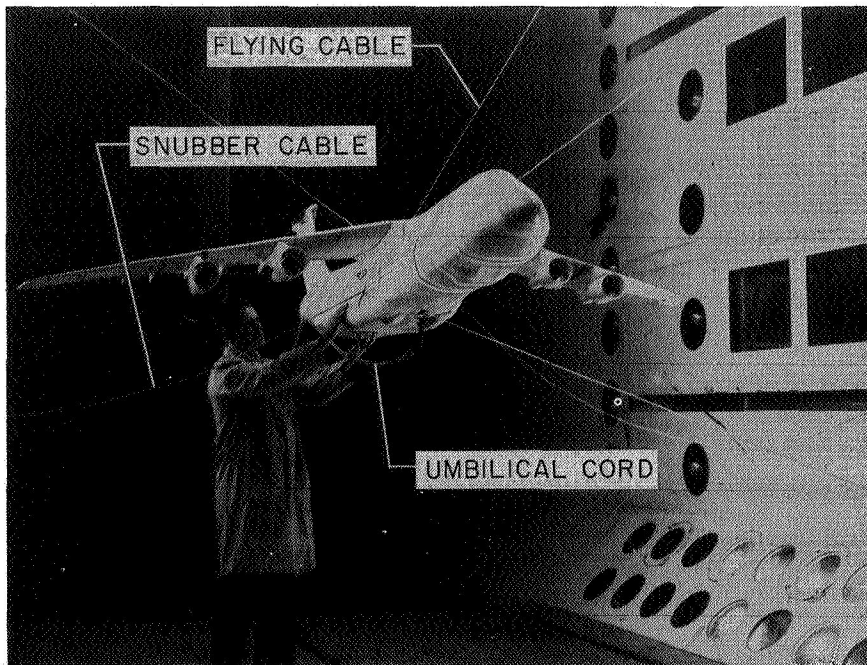

Figure 12.- Model of C-5A with active lift distribution control system in Langley transonic dynamics tunnel.

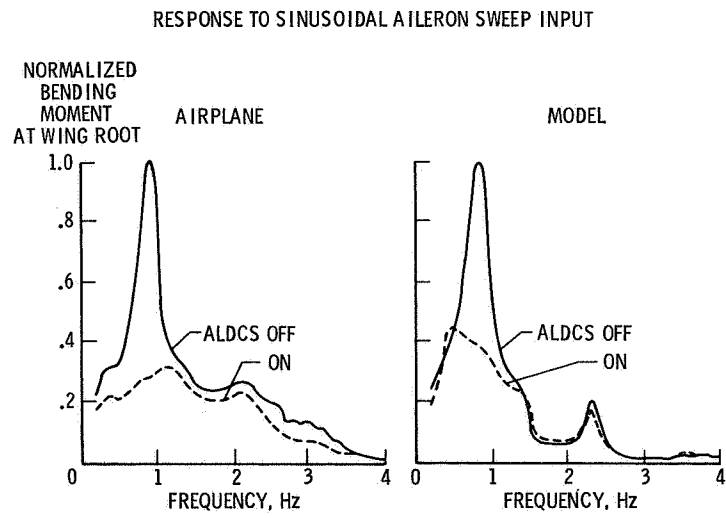

Figure 13.- Characteristics of C-5A active lift distribution control system determined in wind-tunnel and in flight tests.