

General Disclaimer

One or more of the Following Statements may affect this Document

- This document has been reproduced from the best copy furnished by the organizational source. It is being released in the interest of making available as much information as possible.
- This document may contain data, which exceeds the sheet parameters. It was furnished in this condition by the organizational source and is the best copy available.
- This document may contain tone-on-tone or color graphs, charts and/or pictures, which have been reproduced in black and white.
- This document is paginated as submitted by the original source.
- Portions of this document are not fully legible due to the historical nature of some of the material. However, it is the best reproduction available from the original submission.

(NASA-CR-150232) INTEGRATED PAYLOAD AND
MISSION PLANNING, PHASE 3. VOLUME 2:
LOGIC/METHODOLOGY FOR PRELIMINARY GROUPING
OF SPACELAB AND MIXED CARGO PAYLOADS Final
Report (McDonnell-Douglas Astronautics Co.)

N77-21180
HC A08 / MF A01
Unclas
G3/16 24929

**INTEGRATED PAYLOAD AND
MISSION PLANNING, PHASE III
FINAL REPORT, VOLUME II**

**Logic/Methodology for Preliminary Grouping
of Spacelab and Mixed Cargo Payloads**

MCDONNELL DOUGLAS ASTRONAUTICS COMPANY

MCDONNELL DOUGLAS

CORPORATION



**MCDONNELL
DOUGLAS**



**INTEGRATED PAYLOAD AND MISSION
PLANNING, PHASE III**

FINAL REPORT, VOLUME II

**Logic/Methodology for Preliminary Grouping
of Spacelab and Mixed Cargo Payloads**

CONTRACT NO. NAS8-31146

DPD NO. 535

DR MA-04

31 MARCH 1977

MDC G6741

PREPARED BY:

**T. E. RODGERS (TASK LEADER)
J. F. JOHNSON**

APPROVED BY:

R. P. Dawson
R. P. DAWSON
STUDY MANAGER

APPROVED BY:

F. C. Runge
F. C. RUNGE
PROGRAM MANAGER
SPACE PAYLOADS

MCDONNELL DOUGLAS ASTRONAUTICS COMPANY-WEST

5301 Bolsa Avenue, Huntington Beach, CA 92647

PREFACE

This report documents the results of a study conducted by the McDonnell Douglas Astronautics Company (MDAC) from 1 June 1976 to 31 March 1977 for the NASA George C. Marshall Space Flight Center (MSFC) related to integrated payload and mission planning for Space Transportation System (STS) payloads. This Phase III effort is a continuation of the Shuttle payload planning studies initiated by NASA/MSFC in October 1974.

An executive summary of this phase is reported in MDC-6740. Final detailed technical results of this study phase are reported in the following volumes of MDC G6741:

- Volume I - Integrated Payload and Mission Planning Process Evaluation
- Volume II - Logic/Methodology for Preliminary Grouping of Spacelab and Mixed Cargo Payloads
- Volume III - Ground Data Management Analysis and Onboard Versus Ground Real-Time Mission Operations
- Volume IV - Optimum Utilization of Spacelab Racks and Pallets

This Volume II presents the results of an analysis to develop logic and methodology for the preliminary grouping of Spacelab and mixed cargo payloads in a form that can be readily coded into a computer program by NASA. The appendix to this volume contains logic diagrams that should be an aid in the coding process.

Requests for additional information should be directed to the following personnel:

- Mr. R. E. Valentine, Study COR
NASA George C. Marshall Space Flight Center
Huntsville, Alabama 35812
Telephone: 205-453-3437
- Mr. R. P. Dawson, Study Manager
McDonnell Douglas Astronautics Company
Huntington Beach, California 92647
Telephone: 714-896-3205
- Mr. R. D. Nichols, Field Office Representative
McDonnell Douglas Astronautics Company
Huntsville, Alabama 35812
Telephone: 205-881-0611

ACKNOWLEDGEMENTS

The authors of this Volume wish to acknowledge the management and technical assistance given by the following NASA personnel throughout the course of this study:

R. E. Valentine

J. M. Schwartz

CONTENTS

| | | |
|------------|---|------|
| | SUMMARY | xiii |
| Section 1 | INTRODUCTION | 1 |
| | 1.1 Objective | 2 |
| | 1.2 General Approach and Scope | 2 |
| | 1.3 Logic Flow Requirements | 5 |
| | 1.4 Compatibility Criteria | 6 |
| | 1.5 Criterion Modeling—General | 6 |
| | 1.6 Packing Levels | 8 |
| | 1.7 Criterion Modeling—Packing Alternatives | 8 |
| | 1.8 Payload and Flight Configuration | 10 |
| Section 2 | LOGIC DEVELOPMENT | 11 |
| | 2.1 Basic Program Flow | 11 |
| | 2.2 Interactiveness Specification | 12 |
| | 2.3 Launch Interval Restrictions | 12 |
| | 2.4 Group Payloads and Load Onto Flight Configurations | 13 |
| | 2.5 End Options | 19 |
| | 2.6 Automated Payload (APL) | 19 |
| Section 3 | PAYLOAD ORDERING AND OUTPUT MANIFESTS | 21 |
| Section 4 | LOGIC AND METHODOLOGY COMPUTER CODING | 23 |
| Section 5 | CONCLUSIONS | 25 |
| Appendix I | AUTOMATED FLOWCHARTS | 29 |

PRECEDING PAGE BLANK NOT FILMED

FIGURES

| | | |
|-----|--|---|
| 1-1 | Logic for Preliminary Cargo Grouping Analysis | |
| 1-2 | Major Assumptions and Capabilities Affecting Logic Development | 3 |
| 1-3 | Interfaces of Preliminary Cargo Grouping and Detailed Compatibility Analyses | 4 |

PRECEDING PAGE BLANK NOT FILMED

ACRONYMS AND ABBREVIATIONS

| | |
|-------|---|
| APL | automated payload |
| CG | center of gravity |
| FC | flight configuration |
| FCT | flight configuration type |
| IPS | Instrument Pointing System |
| MDAC | McDonnell Douglas Astronautics Company |
| MDE | mission-dependent equipment |
| MSFC | Marshall Space Flight Center |
| NASA | National Aeronautics and Space Administration |
| PL | payload |
| PLH | payload launch configuration height |
| PLHEX | payload extended or deployed height |
| P/M | pallet and/or module |
| RCS | reaction control system |
| SPLAT | Spacelab payload weight available |
| STS | Space Transportation System |
| WPL | weight of payload |
| WPLT | total payload weight |

PRECEDING PAGE BLANK NOT FILMED

PRECEDING PAGE BLANK NOT FILMED

SUMMARY

The purpose of this task was to develop the logic and methodology for a preliminary grouping of Spacelab and mixed-cargo payloads in a form that can be readily coded into a computer program by NASA. The logic developed for this preliminary cargo grouping analysis is summarized below. Principal input data include the NASA Payload Model, payload descriptive data, Orbiter and Spacelab capabilities, and NASA guidelines and constraints (see Figure I-1). The first step in the process is a launch interval selection in which the time interval for payload grouping is identified. This time interval is normally for a specific flight year, however, the program can accept additional increments of time (quarter years), if required. Logic flow steps are then taken to group payloads and define flight configurations based on criteria that includes dedication (by NASA Office or technology), volume, area, orbital parameters, dedication (by NASA Office or technology), volume, area, orbital parameters,

28153

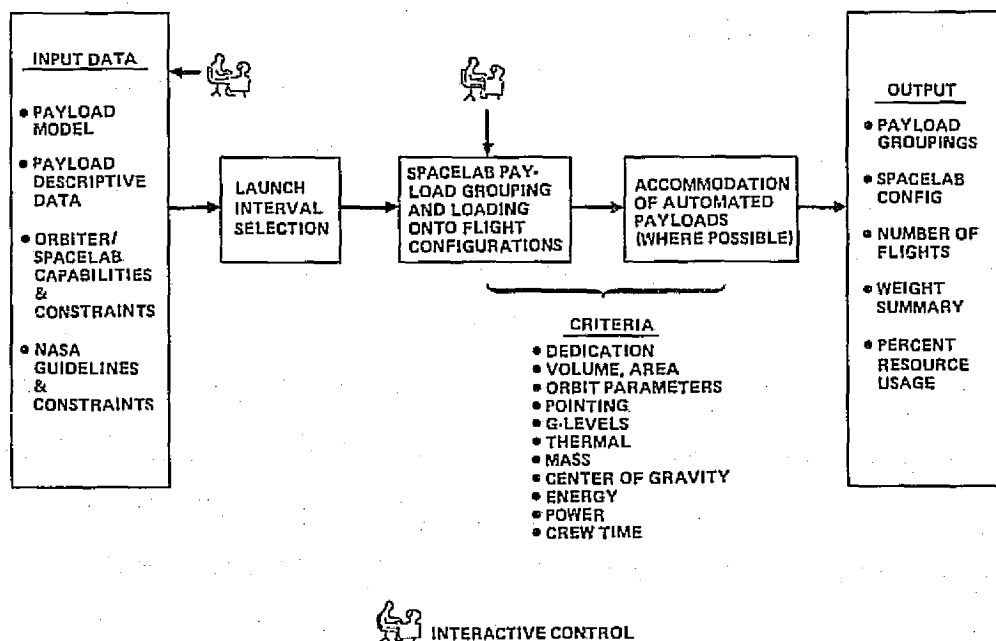

Figure I-1. Logic for Preliminary Cargo Grouping Analysis

pointing, g-level, mass, center of gravity, energy, power, and crew time. After all possible Spacelab payloads have been loaded, the next logic step of the program will permit the accommodation of automated payloads on pallets if all evaluation criteria can still be met (i. e., space, weight, power, etc.). The program has interactive capability - the capability for real-time operation at remote locations by cognizant engineers. The output of this program will include information on payload groupings, Spacelab configuration, the number of STS flight required, weight summaries, and the extent of resource usage.

Section 1
INTRODUCTION

The Space Transportation System (STS) currently under development by NASA will begin a new era of space activity that will involve a significant increase in the number and type of space payloads and missions. To satisfy the needs of the various payload users, and in order to utilize the STS in the most effective way, additional emphasis is being given by NASA to the unique planning and program integration activities necessary to fully exploit STS capabilities. This planning and integration process becomes extremely important when considering the high rate of projected STS traffic, the frequent requirement for payload sharing of STS flights, the varied states of payload development, and the different operational aspects of each payload.

These payload planning and integration activities include preliminary engineering analyses to determine compatible cargo grouping arrangements and Spacelab configurations. To augment this activity, NASA initiated an effort to define an automated program for this purpose. MDAC's support of this effort was to develop the logic and methodology for a preliminary engineering grouping analysis of Spacelab and mixed cargo payloads. This engineering grouping analysis, which is required prior to performing more detailed system engineering analysis, will aid in the selection of the most desirable Spacelab payload groupings and Spacelab configurations.

This report documents the results of the MDAC analyses to develop the logic and methodology for a preliminary cargo grouping program. Section 1 presents introductory information and fundamental methodology development. In Section 2, the general methodology is expanded and the logic flow is developed. In Section 3, the payload ordering and output manifests are expanded. Section 4 presents logic and methodology computer coding. Conclusions are presented in Section 5. Appendix I contains logic flow diagrams which should be of use in the coding process.

1.1 OBJECTIVE

The objective of this effort was to develop the logic and methodology for the preliminary grouping of Spacelab and mixed cargo payloads in a form that can be readily coded into a computer by NASA. Task objectives, approach and general guidelines, and assumptions are summarized on Figure 1-1.

1.2 GENERAL APPROACH AND SCOPE

The overall approach taken was to formulate the general methodology, identify the evaluation parameters, develop the logic flow, determine an input data base format, document the results, and coordinate with NASA programmers during NASA coding operations. The logic and methodology were to be developed in a form that could be readily convertible by NASA to Fortran statements for use with any of the latest high-speed digital computers. Primary emphasis was directed to Spacelab payloads; automated payloads were given secondary consideration. There are eight basic Spacelab configurations covered depending upon core length and rack and pallet combinations. Flight durations up to 30 days are accommodated, however, detailed experiment time line requirements are not considered. The program developed was to have interactive capability, that is, the capability for real-time operations at remote locations by cognizant engineers. The program was developed so that fully dedicated payloads or partially dedicated payloads can be programmed. The program also has the capability to measure resource usage (such as weight, power, etc.) and maintain a reserve allowance.

Major assumptions and capabilities affecting logic development are summarized on Figure 1-2. Efforts were made to maintain a degree of detail that is as simple as possible, yet provides meaningful results. The most significant assumption was that no time line considerations were to be considered. This decision was made because the inclusion of time line evaluation would add significant complexity to the logic, beyond the scope desired for this task.

This task represents the initial step in the planning and integration process to determine payload grouping and configuration. The logic and methodology must then be coded into a computer program by NASA and used to actually conduct preliminary grouping analyses and payload groupings. Following this, additional analysis steps are required to determine final payload groupings.

OBJECTIVES:

DEVELOP THE LOGIC AND METHODOLOGY FOR THE PRELIMINARY GROUPING OF SPACELAB AND MIXED CARGO PAYLOADS IN A FORM THAT CAN READILY BE CODED INTO A COMPUTER PROGRAM BY NASA .

APPROACH:

- 1) FORMULATE GENERAL METHODOLOGY AND IDENTIFY EVALUATION PARAMETERS
- 2) DEVELOP LOGIC FLOW AND INPUT DATA BASE FORMAT
- 3) PREPARE DOCUMENTATION AND PROVIDE COORDINATION WITH NASA PROGRAMMERS DURING CODING

GUIDELINES AND ASSUMPTIONS:

- 1) EIGHT BASIC SPACELAB CONFIGURATIONS
- 2) MAJOR STS RESOURCE USAGE TO BE DEFINED WITH ALLOWANCES FOR RESERVES
- 3) INTERACTIVE OPERATIONAL CAPABILITY TO BE INCLUDED

Figure 1-1. Preliminary Engineering Analysis of Spacelab and Mixed Cargo Payloads — Logic and Methodology (Task 2.1C)

- 1) SPACELAB PAYLOADS GIVEN PRIMARY CONSIDERATION S
- 2) AUTOMATED PAYLOADS GIVEN SECONDARY CONSIDERATION
- 3) EIGHT BASIC SPACELAB CONFIGURATIONS
- 4) ACCOMMODATE FLIGHT DURATIONS FROM 7 TO 30 DAYS
- 5) NO TIME LINE CONSIDERATIONS
- 6) INTERACTIVE CAPABILITY INCLUDED
- 7) MAJOR RESOURCE USAGE DEFINITION

Figure 1-2. Major Assumptions and Capabilities Affecting Logic Development

and configurations based on a more detailed engineering compatibility analysis. An initial step for this detailed engineering cycle is shown in the lower block on Figure 1-3, Systems Engineering Analysis Logic and Methodology, in which the logic and methodology would be developed for a more detailed analysis of payload and cargo compatibility. Once completed and coded into a computer program, it would be used in the overall cargo grouping analysis to determine final payload grouping and configuration.

An expansion of the approach taken is contained in the following sections. These sections treat the problem of how the general logic and methodology was determined for the preliminary grouping analysis. A methodology was developed which generates the logic flow structure up to the point of satisfying problem peculiar constraints. In general, these constraints dictate logic flow configuration requirements. Included are the determination of compatibility criteria that are needed to generate a logic flow structure, and additional diagrams which, when coded, implement the grouping process.

22719

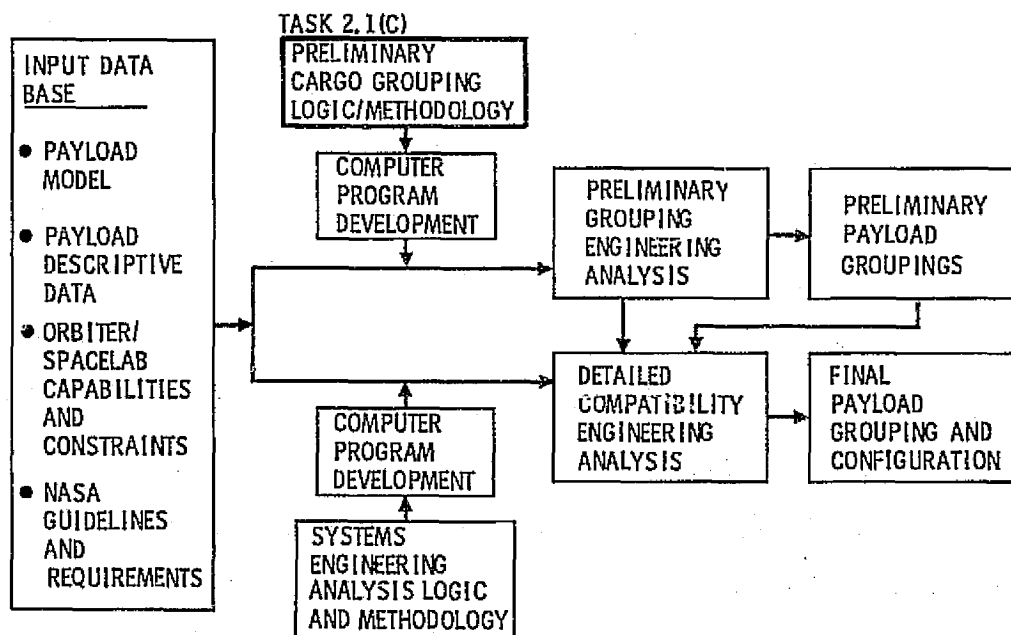

Figure 1-3. Interfaces of Preliminary Cargo Grouping and Detailed Compatibility Analyses

In Section 2, the actual determination of the logic flow structure for the Preliminary Grouping of Spacelab and Mixed Cargo Payloads program is summarized. The payloads to be loaded, flight configurations, compatibility criteria, and problem peculiar constraints are identified, and a logic flow structure is generated.

1.3 LOGIC FLOW REQUIREMENTS

In order to determine the logic flow, the following requirements were considered:

- A. Method for the determination of reasonable logic flows,
- B. Method for the evaluation of logic flows,
- C. Allowances for problem peculiar constraints (i. e., unique constraints imposed by a particular problem).

In order to achieve these ends, the basic segments of logic flow via logic components are defined as:

- Payloads
- Sets (Groups of Payloads)
- Criteria
- Flight Configurations

For a complete grouping process, all payloads must be evaluated against all criteria. This is equivalent to arranging the criteria in a linear (series, string) fashion and successively passing the elements through the string. In order to maintain the detail of the preliminary grouping process to its intended purpose, requirement (A), preceding, is limited to a specific set of criteria which are discussed later.

The determination of a method for evaluating logic flow necessitates logic flow criteria. One set of criteria that was desirable to satisfy was that the logic flow be workable, flexible, and fast. In this context, workable means that the logic flow performs in a reasonable manner, is not too complex, and solves the problem to the intended level of detail. The logic flow must be flexible since the input items may not be entirely defined and since it may be desired to modify the criteria set as more information becomes available. Since the logic flow will eventually be developed into a Fortran coded computer program, the logic must be developed so that the resulting computer program will provide rapid calculations.

1.4 COMPATIBILITY CRITERIA

The compatibility criteria are determined from an evaluation of the characteristics of the payloads to be loaded and of the flight configuration characteristics. The number and type of characteristics used for the criteria determination defines the level of compatibility sought in the problem solution.

The previously identified requirement that the flow be fast may be satisfied by minimizing the number of decisions (i. e., criteria test of items). One method which may be used to minimize the number of criteria tests is to order (group) the criteria with the most restrictive criteria first. This procedure reduces the number of payloads that successive criteria must test and hence reduces the number of decisions. Two possible methods for the determination of restrictiveness are:

- Direct Evaluation
- Incompatibility Matrix

In the direct evaluation, a criterion is chosen and each payload is tested against the criterion. The number of payloads which pass the test is an indication of restrictiveness. The more restrictive the criterion, the greater the number of payloads which are rejected.

To determine restrictiveness, a quantitative evaluation may be performed as above or qualitatively ordering of the criteria from a reasonableness standpoint may be performed.

To accommodate these requirements, the following constraint was imposed on the methodology process:

- Criteria in the logic flow are ordered according to restrictiveness with the most restrictive criteria first.

1.5 CRITERION MODELING - GENERAL

The determination of pertinent compatibility criteria and their levels of restrictiveness may be facilitated by:

- Grouping criteria to develop trends and differences.
- Modeling criteria for more effective testing.

The criteria were modeled to achieve the grouping referred to above. Modeling a criterion may be a straightforward process or very complex. In general, the more complicated that the model is, the more yes-no decisions that are required to test a payload against the criteria.

The model which was used for the majority of the quantitative criteria is the simple additive model, given in the following example.

Example:

Criterion - Mass (quantity)

Model Type - Additive (add the mass [quantity] of the payload which is currently loaded to the mass [quantity] of the payloads already loaded)

Decision Test - Does the total mass (quantity) exceed the available level?

In place of the quantity mass, other additive criteria examples are energy, crew time, etc. A second model type which was used is that of parameter matching.

Example:

Criterion - Discipline (parameter)

Model Type - Parameter matching

Decision Test - Is the discipline (parameter) of the payload currently being loaded the same as the discipline (parameter) specified?

In place of the parameter discipline, other examples are g-level, pointing, etc. The last type of model which was used is that of rearrangement.

Example:

Criterion - CG

Model Type - Rearrangement (rearrange elements on the container according to a subcriterion)

Subcriterion - Mass

Decision Test - Once rearrangement has been performed, has the CG (criterion) test been satisfied?

Note that the actual specification of the physical rearrangement has not been given. This specification depends on the criterion type specified in Section 2.

Time line rearrangements would require complexity beyond the scope of this study and therefore were not considered. However, in some cases, time duration factors were considered.

If a criterion decision test is not satisfied, then the payload is rejected. It was assumed, for the grouping problem, that all payloads must be loaded. The rejection option was then defined as:

Rejection - Due to incompatibility, the payload (PL) cannot be loaded on any used flight configuration (FC) (a FC which contains previously loaded PLs). An unused (empty) FC was then defined and the PL was loaded onto it.

Tolerance levels were considered as part of the criterion modeling process, that is, some criteria may have tolerance levels specified in addition to normal maximum levels.

1.6 PACKING LEVELS

Packing problems may in general be divided into levels. Examples for loading payloads onto the Spacelab are:

- One packing level - PL loaded onto FC
- Two packing levels - PL loaded onto pallets and/or modules (P/M), P/M loaded onto FC
- Three packing levels - PL loaded onto P/M, P/M grouped into pairs, and P/M pairs loaded onto FC

The packing process with three packing levels was not as flexible as that with lesser levels since it was more difficult to pack pairs than single P/M. Further, although it is felt that some added PL grouping control was achieved by utilizing more than one packing level, the single packing level, (i. e., PLs directly onto FCs) was chosen due to the more general simplicity of the logic and the corresponding reduction of computation time and computer file storage requirements in the computer program.

1.7 CRITERION MODELING - PACKING ALTERNATIVES

The process for evaluating criteria restrictiveness through criterion modeling has been defined in Subsection 1.5. Rejection of PL by a criterion, i. e., the PL fails the decision test, is one possibility and is the default option. In the preliminary grouping of payloads, rejection would mean that a particular PL would not be loaded onto a particular FC.

Packing alternatives are also options encountered in the loading process given in the following examples.

Examples:

Rearrangement - FC CG out of CG envelope, therefore rearrange pallet and module locations (i. e., select new FC).

Replacement - Sum of pallet weight exceeds maximum, therefore remove a pallet and substitute another pallet.

Adaptability - Sum of crew time requirement exceeds available, therefore add another crewman.

In addition, another packing alternative was identified.

Example:

Intervention (Interactive Capability) - Sum of PL energy exceeds maximum by 2 percent; human decision allows this PL grouping regardless of energy overrun.

Precise definitions of the packing alternatives must be developed, e. g., if PLs are to be rearranged on a pallet or in a module, what is the specific plan of action for the rearrangement?

A basic ordering for the packing alternatives associated with a criterion may be determined and depends on the criterion. For example, for the criterion of FC CG outside of CG envelope, replacement of a pallet from one FC to another FC may be more difficult than pallet rearrangement within an FC once other criteria have been satisfied.

Other constraints are now identified which reduce the complexity of the logic flow.

- Consider only the following packing alternative, and define restrictiveness order for packing alternatives (least restrictive first) as follows:
 - A. Adaptability
 - B. Rearrangement
 - C. Replacement

- D. Intervention (interactive capability)
- E. Rejection

In general, it is easier to adapt and rearrange than it is to replace if a compatibility criterion is not satisfied. Since replacement is really a special case of rearrangement, replacement was eliminated for the sake of simplicity.

The above listing was used to order the criteria. This ordering is accomplished using the following constraint:

- Criteria restrictiveness is determined from the applicable criterion packing alternatives.

1.8 PAYLOAD AND FLIGHT CONFIGURATION

Some PLs are more demanding on FC resources than others and would therefore be more difficult to load once other PLs have been loaded. It was therefore desirable to facilitate the packing process by ordering and loading the most demanding PLs first. Demanding depends on the particular PLs, FCs, and criteria.

To order the PLs to be sent through the logic of the grouping process, a PL resource table was defined. The resource table elements are the percentages of the FC resources used by the PLs. The percentages for each PL are added across the row with an optional weighting factor for each resource. In a sense, the PL with the largest total is most demanding, i. e., the most difficult to load, and is loaded first. By arranging the totals in descending order, the PL ordering is defined. The PL Resource Table, in Appendix I, will be used in Section 2 for ordering PLs.

The FCs for the general packing problem may also be classified according to type, and all PLs may not be compatible with all types of FCs. The FC types may also be ordered according to criteria.

There are special considerations which affect the PL ordering and FC type selection. Two examples are sets of PLs that should always fly together and FC that have dedication requirements. These are discussed in more detail in Section 2.

Section 2 LOGIC DEVELOPMENT

The fundamental methodology development has been presented in Section 1. In Section 2, the general methodology has been expanded, leading to the actual logic flow diagrams. The results of the logic development are presented in Appendix I for convenience of handling during the coding process. The input data requirements and the actual logic diagrams are presented in Appendix I. In the following Sections, all Tables and Figures referred to are contained in Appendix I. Table and Figure numbers are not consecutive as they correspond to block numbers within the flow diagrams.

2.1 BASIC PROGRAM FLOW

The logic development, as discussed in Section 1, is based on one level loading, i. e., loading of Spacelab PLs directly onto FCs with no intermediate consideration of non-FC related pallets or racks. The basic or main logic flow control is depicted in Figure 1.0. The basic input data bases are included in the logic blocks which are open-ended on the left-hand side. Additional operational data files are indicated in blocks 1.8, 1.9, and 1.10. These blocks or data files are established once and subsequently updated or modified only as new data or experience warrant. Program initiation begins in block 1.12. The remaining blocks of Figure 1.0 refer to subsequent logic diagrams where the actual or detailed logic flow is presented. The remaining discussion considers each logic diagram in the order that the computerized flow would occur.

The PL model and the PL data base input data parameters are listed in Tables 1.1 and 1.2 respectively. The basic Spacelab FC data base and the Orbiter capabilities and constraints are listed in Tables 1.3 and 1.4, respectively. Table 1.5, basic data base file, contains parameters which do not naturally belong in the previous data base files. The criterion characteristics are shown in Table 1.8. The criteria are listed, not in any particular

order, showing the packing alternatives and nature of adaptability, if any. The ordered criteria (the order in which they will be evaluated for each PL) are listed in Table 1.9. Finally, the criterion model definition for each criterion is shown in Table 1.10.

2.2 INTERACTIVENESS SPECIFICATION

The interactiveness specification logic flow shown in Figure 2.0, data base changes in Figure 2.2, FC dedication options in Figure 2.3, and tolerance parameter interactive options in Figure 4.0, are executed at this point. All other interactive options occur at appropriate places in subsequent logic flow with some flags being set in Figure 2.0. The subsequent interactive options are clearly called out as they occur and will be discussed at that time.

With interactive capability, the user will be able to make changes to this data base on any given run, as desired. A major feature of the interactive control is the dedication option. The user can specify one or more flights to be dedicated to either one or a combination of two program offices. In addition, for each flight with two-office dedication, resource percentage splits can be specified (e. g., split loading by weight, Office of Applications 60%, ESA 40%). Also, the amount (%) of reserves for selected resources can be specified. The final interactive option is that of repacking at the end of the logic flow. The user will be able to observe the resource usage tables and attempt to move any selected PL from one FC to another.

2.3 LAUNCH INTERVAL RESTRICTIONS

Following the initial interactive options, control is returned to Figure 1.0 and the launch interval restriction logic, Figure 3.0, is called. This logic simply selects all of the PLs out of the total PL Model for the desired PL grouping year currently being considered. These PLs are then stored in a separate file for further manipulation.

The basic process is to select the PLs out of the PL model for a specified year and group them into FCs. However, additional flexibility is provided

as the user may specify any number of quarter years to be included in addition to the specified beginning year. Two grouping options are then available:

1. Group all PLs for the interval year (1) + N quarter-years.
2. For the specified interval (year (1) + N quarter-years), group the PLs by quarter-year segments within that interval.

2.4 GROUP PAYLOADS AND LOAD ONTO FLIGHT CONFIGURATIONS

The heart of the grouping logic begins with Figure 7.0, group PLs and load onto FCs. Throughout the 7 series of logic flow diagrams, control is transferred to various segments of the logic for evaluation of the PL criteria with each attempt to load a PL onto a FC.

The first step in Figure 7.0 is to transfer control to Figure 7.3 where the PLs of interest (Reference Figure 3.0) are ordered. They are first ordered by calculating the percent of total resource available in the FC that is required by the PL. A matrix file is built, doing this for each additive criterion for each PL. The matrix rows for each PL are then summed using input multiplying or weighting factors for each criterion as shown in Table 7.3.9. The PLs are then ordered in descending order according to the summed totals. Next, the list is sorted for each office-dedicated flight. Each office-dedicated group is moved to the top of the list so that they will be selected for loading during the early execution of the logic. Control is now transferred to Figure 7.4 for special PL grouping designations. Here one or more sets of PLs can be designated to always fly together. Since loading a set of PLs onto a FC may present special loading problems, these designated sets are moved to the top of the ordered PL list so that they will be loaded first.

Actual loading of PLs onto FCs now begins. First, the specially designated groups of PLs that must fly together are loaded. After these special sets have been loaded, selections of PLs from the ordered PL list will continue. If dedicated flights are required, these PLs will be the next PLs on the list. It should be noted that there is a test (Figure 7.0, Blocks 7.4 and 7.4.1) to determine when all of the dedicated flights have been satisfied. When this is determined to be the case, the dedication criterion is removed from the ordered criterion list for the duration of the run. This makes it possible to attempt to load the remaining multiuser PLs onto the dedicated FCs if

available resources permit. In this manner, each remaining PL in the list is successively selected for loading onto a FC.

The first criterion to be tested for each PL is the Instrument Pointing System (IPS) requirement. This is done by transferring from Figure 7.0 to Figure 25.0, and returning. The IPS criteria is checked first because it has an impact on subsequent criteria that will be evaluated.

2.4.1 FC Selection and Criteria Evaluation

Transfer of control is made from Figure 7.0, Block 7.7, to Figure 7.7 for FC selection and criteria evaluation. First, the PLs are tested for special grouping requirements. If there is a requirement, the FC is established for the first PL of the set and all subsequent PLs of that set are loaded onto the same FC. If the PLs are not of a special set, then the test is made to determine if a specific FC type (FCT) is designated for that PL. If so, the logic increments through the FC manifest and selects the first FC of the desired type. If the PL cannot be loaded on that FC, the incrementing continues until the next FC of the desired type is selected. If the FC list is exhausted, then a new FC of the desired type is established. If no FCT dedication requirements exist, the logic simply increments through the FC manifest until the PL is loaded. The criteria tests begin in Figure 7.7, Block 7.7.8, where control is transferred to Figure 7.7.8. The logic begins incrementing through the criterion list (Table 1.9), checking for possible packing alternatives.

2.4.2 Dedication Criterion

Since the pointing and IPS criteria have already been checked, the first criterion selected from the list is dedication. This is a parameter match model FC Office designation to PL Office designation. The parameter match model is in Figure 7.21. If the parameter match is made, the test is satisfied. After the last PL with a FC dedication is selected from the ordered PL list, the criterion dedication is deleted from the criterion list for the duration of the run. As previously indicated, this is done to permit the remaining multi-user PLs to be loaded on the dedicated FCs as available resources allow.

2.4.3 Mass Criterion

This criterion is additive, so control is transferred to Figure 7.20. The criterion here is: After adding the weight of PL (WPL) to the FC, does the total PL (chargeable) weight (WPLT) exceed the FC Spacelab PL weight available (SPLAT)? Additional weight checks are made for individual pallets and racks in the pallet and/or rack volume-area check.

2.4.4 Orbit Parameters

The acceptability of PL orbit parameters for a given FC is evaluated in the logic flow contained in Figures 23.0, 23.5, 23.7, and 23.10. This flow also provides consideration of mission duration extensions.

2.4.5 Volume Area Loading Check

The initial pallet and rack volume-area loading check is controlled in Figure 24.0. Since this logic is more complex than the other criteria tests, the first step is an interactive stop, allowing the user to instruct the PL to be loaded and bypass the logic. If he types in LOGIC, then the logic flow continues as follows. If the PL involves rack loading, this is accomplished in Figure 24.2 and is checked on the basis of total volume. Dedicated racks for specified PLs can be accommodated. The pallet loading becomes more complex. The pallet loading is three dimensional in that both above and below mid-deck loading is considered. Since viewing and/or gimbaling PLs are probably the most restrictive to load from a volume-area consideration, a preliminary test is made for the viewing PLs. The viewing requirement is identified in Figure 24.4. If the requirement exists, control is transferred to Figure 24.9 for preliminary checks. This logic first checks to see if the PL can be mounted above mid-deck and remain within the upper PL envelope constraint in the cargo bay. The result of this test is simply that a flag is set indicating whether the PL must be mounted above mid-deck or below mid-deck on the pallet floor structure.

Next, in Figure 24.9.1, the PL area is checked against the available area and the PL weight is checked against the available weight. One, two, or three pallet train requirements are considered by the control passing through Figures 24.11, 24.12, and 24.13, as indicated.

To this point, the logic has tested area (in the launch stowed condition), weight, and cargo bay envelope. This could be whether the PL has viewing and/or gimbal requirements or not. Next, if the PL has viewing and gimbal requirements, control is transferred to Figure 24. 10. In this logic, the PL height is considered to be the PL extended or deployed height (PLHEX) as opposed to the PL launch configuration height (PLH). In Figure 24. 10, some basic computations are made concerning viewing and/or gimbal type PL heights for the appropriate viewing and/or gimbal angle. These values are retained for subsequent tests at a more detailed level.

Returning to Figure 24. 4, Block 24. 4. 7, if the PL has no viewing and/or gimbal requirement, control is transferred to Figure 24. 5 for below mid-deck loading checks. These preliminary tests are for total area, height, and weight, considering one, two, or three pallet train requirements as before. If the PL cannot be loaded below mid-deck, similar checks are made in Figure 24. 8 for above mid-deck loading.

Once a pallet of a FC has been loaded to the point that the loaded area exceeds the available area minus some input factor, control will be transferred from Figure 24. 9. 1 to Figure 24. 20 for a detailed area placement check.

The basic principle for the more detailed pallet loading evaluation is to section off the below and above mid-deck areas into rectangular sections as shown in Table 24. 20. The intent is to end up with reasonably good confidence that the PLs grouped on a given pallet can in fact be accommodated when actual layouts are made in the next level of compatibility analysis. If desired, this detailed pallet PL placement logic can be included in the initial program coding or it could be added at a later date to facilitate early operation of the program.

As seen in Table 24. 20, there are 12 sections below and 20 sections above mid-deck for a single pallet. These numbers are doubled and tripled for two and three pallet trains, respectively. In Figure 24. 20, the appropriate number of sections are established according to the current pallet configuration being considered. Next, the below mid-deck PLs for the current pallet

configuration are selected and ordered according to the fraction of the available area that the PLs require. Thus, the largest PL will be placed first, the smallest last. The same procedure is accomplished for the above mid-deck PLs.

Next, in Figure 24.21 and 24.22, the below mid-deck PLs are placed on the pallet. The procedure consists of selecting the next PL from the newly ordered list. A spacing factor is applied to the PL width and length to allow for some spacing between adjacent PLs after loading. Using these scaled PL lengths and widths, the number of sections required by the PL is defined. The first section on the pallet is now selected (section 1. 1). If this section is available on the pallet and more sections are required lengthwise, then the next section lengthwise is selected. This procedure is followed until the PL length can be loaded or a conflict with an unavailable section is met. The same procedure is followed widthwise. If the PL can be loaded, the selected sections are deleted from the available section list for the current pallet. This includes above mid-deck sections if the PL height extends above the mid-deck level. This is the reason below mid-deck PLs are placed first. If an unavailable section conflict is identified, the logic will continue to select the next section until an available section is found. The procedure then continues, attempting to place the PL. If the PL cannot be placed below mid-deck, it is added to the above mid-deck list for possible placement there.

When all of the below mid-deck PLs have been placed or changed to the above mid-deck list, a similar procedure for placing PLs above mid-deck is followed. At this point, if it is determined that some PLs cannot be placed at all, the logic will interactively ask the user if he wishes to override the logic and load the PL anyway.

One feature is, that for a gimbaling PL, the area is increased to equal the projected area assuming the PL gimbals around the full circumference. For viewing PLs, no PLs will be loaded in an adjacent section if the new PL height would protrude above the upper edge of the viewing PL, even if in a gimbaled position. Again, these calculations consider the PL heights to be in the extended or deployed position. This is the viewing conflict test in Figure 24.28.

2.4.6 Power

The power criterion is evaluated in Figure 7.2.2. Using the operating power, duration of each operation, frequency of operation, and mission duration, the total power consumption for each PC is calculated. Then for each FC, a power information manifest is maintained. A sample is shown in Table 7.2.2.

2.4.7 Pointing - Reaction Control System (RCS) Fuel

This criterion is modeled in Figure 7.18. The additional fuel is added, based on input data contained with the PL being evaluated.

2.4.8 G-Level

The g-level criterion is modeled in Figure 27.0. This model establishes the duration that different g-levels are required for each mission. This is done for the purpose of output information as opposed to a criterion test.

2.4.9 Continuous Thermal Heat Rejection

This criterion is an additive model using Figure 7.21. It is a gross check of the accumulated average heat rejection requirement.

2.4.10 CG Criterion

The CG criterion is a tolerance range test with the rearrangement alternative. This logic is contained in Figures 7.17 and 7.17.1. Only longitudinal CG is considered. The flow initiates in Figure 7.17. The new FC CG is calculated in Figure 7.17.1 and returned to Figure 7.17. Here, the CG out-of-tolerance range test is made. An acceptance is indicated even if the CG is out of tolerance by 10% or less in order to account for uncertainties in current CG data.

2.4.11 Energy

This criterion is an additive model using Figure 7.18. The total energy required by each PL is summed and checked against the available energy.

2.4.12 Crew Attendance Time

This criterion is modeled in Figure 7.19. The model accumulates the total crew attendance time required for each PL and determines if additional Spacelab crewmen beyond the baseline of two are required. If so, the additional weight provisions are added.

2.5 END OPTIONS

After the last PL is loaded, the logic executes several end options. First, in Figure 13.4, an additional opportunity is made for the user to interactively add mission dependent equipment (MDE) to the loaded FCs. Then, if the tolerance option flag is set, the logic in Figure 13.1 will determine from the resource usage table the percentage of each resource used for each FC. It then establishes an incompleted FC loading manifest. This information can be displayed and used in the next option. The next option is that of interactively repacking or rearrangement of PLs in a FC or from one FC to another. This logic is in Figure 13.2.

2.6 AUTOMATED PAYLOAD (APL)

If resources allow and all PLs have been loaded, then an attempt is made to load APLs onto pallets. The APLs are deployed at the beginning of the Spacelab mission. The loading attempt is made at the completion of the loading of the FCs. The FC resources which are used as loading criteria are listed in Table 26.1 and the logic flow is illustrated in Figure 26.0.

Two possible situations in which APLs may be assigned to a FC are (1) the pallets on a FC do not deplete the FC resources, and (2) an FC occurs in the output manifest in which another pallet could be added, changing the type of the original FC. The logic flow for loading APLs handles both of these cases.

Section 3

PAYLOAD ORDERING AND OUTPUT MANIFESTS

As part of the process, the payloads which are to be sent through logic are ordered. To this end, element resource tables are employed which allow payload ordering on the basis of the percentages of FC resources used. The ordered payload manifests are used as PL loading input and the result is an output manifest. The PL resource table consists of that part of a manifest which contains the percentages of available resources used for additive criteria. The percentages are summed across the rows to obtain percentage totals.

A sample input ordered payload model is given in Table 7.3.9. The ordered PL manifest, Table 7.4, is then constructed. Table 8 illustrates a sample FC output manifest for a 5% tolerance level. The associated weight summary is given in Table 9. The FC ordering is shown in Table 10.

PRECEDING PAGE BLANK NOT FILMED

Section 4

LOGIC AND METHODOLOGY COMPUTER CODING

The computer program which implements the logic and methodology for the grouping of Spacelab payloads consists of Fortran coding and a set of computer files (Table 11).

As an example of the implementation of the criterion decision process via the program and files, consider the criterion energy. From the ordered criteria file, Table 1.9, it is seen that the criterion CG has just been satisfied and the program goes on to the next criterion. The ordered criterion index is incremented, Figure 7.7.8, and the criterion energy is selected.

As stated, the criterion index in the criterion model definition file, Table 1.10, is incremented until ENERGY is located. The information provided here includes the fact that the criterion is represented by an additive model and 25% (example) tolerance. The additive model subroutine, ADDITIVE, which contains the criterion model procedure and decision test is then called as in Figure 7.20. For this example, the element quantity, QUANT, is equal to ENERGY. This logic block in Figure 7.20 fits into the criterion decision test block of Figure 7.7.8.

Another criterion model type which is considered is that of parameter matching. In this case, the check under parameter match in the criterion model definition file (Table 1.10) instructs the program to call subroutine PARAMATCH as in Figure 7.21.

The criterion files may be expanded in scope to provide for more detailed models.

The input data base requirements are summarized in Table 12.

PRECEDING PAGE BLANK NOT FILMED

Section 5
CONCLUSIONS

The logic and methodology for a preliminary grouping of Spacelab and mixed cargo payloads has been developed in a form that can be readily coded into a computer program by NASA. Principal input data include the NASA Payload Model, payload descriptive data, Orbiter and Spacelab capabilities, and NASA guidelines and constraints. The first step in the process is a launch interval selection in which the time interval for payload grouping is identified. This time interval is normally for a specific flight year, however, the program can accept additional increments of time (quarter years), if required. Logic flow steps are then taken to group payloads and define flight configurations based on criteria that includes dedication (by NASA Office or technology), volume, area, orbital parameters, pointing, g-level, mass, CG, energy, power, and crew time. After all possible Spacelab payloads have been loaded, the next logic step of the program will permit the accommodation of automated payloads on pallets if all evaluation criteria can still be met (i. e., space, weight, power, etc.). The program has interactive capability, the capability for real-time operation at remote locations by cognizant engineers. The output of this program will include information on payload groupings, Spacelab configuration, the number of STS flights required, weight summaries, and the extent of resource usage.

The process which generates the logic and methodology for the grouping analysis has been developed for use in the preliminary grouping of Spacelab payloads. This process manifests itself in a set of logic diagrams. Computer diagrams within the process will be coded to implement the grouping process. The process allows flexibility. If additional criteria are desirable they may be added along with packing alternatives, packing levels, tolerance levels, and adaptabilities. Also, one can subtract criteria, change criteria characteristics (tolerances, alternatives), and change the data base.

APPENDIX I

AUTOMATED FLOWCHARTS

PRECEDING PAGE BLANK NOT FILMED

Appendix I
AUTOMATED FLOWCHARTS

This appendix contains the logic diagrams which have been automated by the use of MDAC computer program MACFLO. Each logic diagram block is indexed with a number. When transfers in the logic are made from one diagram to another, the indexing allows one to locate the go-to-point with a minimum of effort. It is intended that these diagrams will aid the coding process.

PRECEDING PAGE NOT FILMED

DEFINITIONS OF SYMBOLS

| | |
|--------------------------------|--------------------------------------|
| APL | Automated payload |
| C | combination |
| CG | center of gravity |
| FC | flight configuration |
| FC _{l,m} | FC type l, number m |
| .GE. | greater than or equal |
| .GT. | greater than |
| HA | apogee altitude |
| HP | perigee altitude |
| III | inclination |
| LCG | longitudinal CG |
| LE | less than or equal |
| LT | less than |
| M | module |
| M _i | mass of P/M number i |
| M _{ij} | mass of P/M _{ij} |
| M ^o _{ij} | mass of P/M _{ij} with no PL |
| M ^{PL} _{kjk} | mass of PL K on P/M _{ij} |
| MD | mission duration |
| MDE | mission dependent equipment |
| MAX | maximum |
| MIN | minimum |
| NOM | nominal |
| OMS | orbital maneuvering system |
| P | Pallet |
| PL | payload |
| P/M | pallets and/or modules |
| PO | pallet only |
| PPDB | PL planning data base |
| RCS | reaction control system |

TABLE 1.1

PAYLOAD MODEL REQUIREMENTS

The following information should be identified for each Payload.

A. Spacelab Payloads

1. Identifying descriptor number (ID)
2. Alphanumeric Name
3. Launch year(s)
4. Number of flights for each year.
5. Payload Discipline
6. NASA Office or other organization of responsibility

B. Automated payloads. (APL)

1. Identifying descriptor number (ID)
2. Alphanumeric Name
3. Responsible Organization.

TABLE 1.2
PAYLOAD DATA BASE

A. Spacelab Payloads

1. Identifying descriptor number
2. Alphanumeric Name
3. Launch year(s)
4. Number of flights for each year
5. Payload discipline
6. NASA Office or other organization of responsibility
7. For each payload or experiment segments of a Payload that are to be mounted in racks or pallets separately, identify the following data.
 - 7.1 Payload loading requirement, Pallet (P), Pallet only (PO), Pallet-Module combination (C), Module Rack (R).
 - 7.2 Pressurized mounting requirement (yes or no).
 - 7.2.1 PL width (PLW)
 - 7.2.2 PL Volume (PLV)
 - 7.2.3 Launch and entry weight (WPL)
 - 7.3 Unpressurized mounting requirement (yes or no)
 - 7.3.1 Overall dimensions (length, width, height), (PLL, PLW, PLH).
 - 7.3.2 Inputs to volume - area test
 - a. P(I) Number of pallets in train, I = 1, 2 or 3.
 - b. P(X) Pallet index
 - c. PL Area (PLA)
 - d. AMDADN - available mid-deck area underneath
 - e. AMDAUP - available mid-deck area up (top side)
 - f. TPLWT - Total PL weight loaded on pallet*
 - g. Pallet weight carrying capabilities.

| TRAIN CONF. | WITHOUT IGLOO | WITH IGLOO |
|--|---------------|------------|
| P(I) = 1 | WT[P(I)] | WT[P(I)I] |
| P(I) = 2 | WT[P(I)] | WT[P(I)I] |
| P(I) = 3 | WT[P(I)] | WT[P(I)I] |
| h. TMDADN - Total mid-deck area loaded underneath* | | |
| i. TMDAUP - Total mid-deck area loaded above* | | |

*Calculated

- j. AF - Loading area factor
- k. PLH - PL height (launch condition)
- l. PLHEX - PL height extended
- m. HL₁ - Height of mid-deck above floor panel.
- n. HU - Height from upper surface of mid-deck to top of pallet.
- o. WMD - width of mid-deck
- p. R - Radius of PL envelope
- q. PHI - Half Gimbal Angle
- r. PLS - Payload shape, cylindrical or rectangular
- s. PLD - Cylindrical PL diameter
- t. PLL - PL Length
- u. PLW - PL width
- v. MDADN - Unloaded mid-deck area underneath*
- w. MDAUP = Unloaded mid-deck area above*

7.3.3 Launch and entry weight (WPL)

7.4 Crew requirements

7.4.1 Total crew attendance time required for PL, TA

7.4.2 Hours per day per crewman available, H.

7.4.3 Weight per crewman, WC.

7.4.4 Weight provisions per crewman per day, WP
(nominal 7 day mission)

7.4.5 Weight Provisions per crewman per day, WPC
(for missions extended past 7 days)

7.5 Total energy usage, KW

7.6 Average continuous power usage, W

7.7 Average continuous Heat dissipated by PL, W

7.8 PLG - level constraint (yes or no) if yes, enter 7.8.1 & 7.8.2 data

7.8.1 Operating g-level constraint

7.8.2 Total operating duration for g-level

7.9 PL Mission duration requirement

*Calculated

7.10 Orbit parameters

7.10.1 Any orbit acceptable (yes or no). If no then no input data in 7.10.2

7.10.2 PL apogee and perigee altitude (NMI) and inclination (Deg) (nominal, maximum and minimum)

PLHAMIN, PLHANOM, PLHAMAX

PLHPMIN, PLHPNOM, PLHPMAX

PLINMIN, PLINNOM, PLINMAX

7.11 List of MDE needed for PL

B. Automated Payloads (APL)

1. Identifying descriptor number (ID)

2. Alphanumeric name

3. Responsible organization (Information only)

4. Launch and entry weight

5. Deployment orbit parameters, PL apogee and perigee altitude (NMI) and inclination (Deg) (Nominal, maximum and minimum).

PLHAMIN, PLHANOM, PLHAMAX

PLHPMIN, PLHPNOM, PLHPMAX

PLINMIN, PLINNOM, PLINMAX

6. PL length

TABLE 1.3

BASIC SPACELAB FLIGHT CONFIGURATION DATA BASE

- 1.0 Basic Spacelab flight configuration list
 - 1.1 CORE PLUS EXPERIMENT MODULE
 - 1.2 CORE MODULE PLUS 9 METER PALLET
 - 1.3 6 METER PALLET PLUS 9 METER PALLET
 - 1.4 THREE INDEPENDENTLY MOUNTED 3 METER PALLETS
 - 1.5 CORE MODULE PLUS 6 METER PALLET
 - 1.6 CORE AND EXPERIMENT MODULE PLUS 6 METER PALLET
 - 1.7 CORE AND EXPERIMENT MODULE PLUS 3 METER PALLET
 - 1.8 TWO 6 METER PALLETS

- 2.0 Mass Properties
 - 2.1 Basic Configuration Weight
 - 2.1.1 Total
 - 2.1.2 Individual module weight (includes airlock, tunnel, basic structure, module), and individual pallet weight.
 - 2.1.3 Single and double rack Payload weight carrying constraint.
 - 2.1.4 Pallet weight carrying constraint
 - 2.1.5 Launch and landing weight limits
 - 2.1.6 Launch and landing CG constraints
(Table of CG location constraint vs Spacelab Payload chargeable weight).
 - 2.1.7 Weight available for Spacelab Payload chargeable weight items.

- 3.0 Volume and mounting area available.
 - 3.1 Single rack volume and width.
 - 3.2 Double rack volume
 - 3.3 Pallet mounting area
 - 3.4 Distance from front of bay to front end of Modules and Pallets.

- 4.0 For each configuration,
 - 4.1 Energy available
 - 4.2 Continuous average heat rejection capability
 - 4.3 Continuous average power available

- 5.0 Spacelab MDE list

TABLE 1.4

ORBITER CAPABILITIES AND CONSTRAINTS DATA BASE

Weight and CG of APPS

Weight of:

OMS orbiter fuel requirement (nominal and extended missions)

RCS orbiter fuel requirement (nominal and extended missions)

EVA equipment above Orbiter baseline

EPS kits

Second Orbiter remote manipulator system

Second orbiter TDRSS antenna

Extra hardware and consumable required for missions longer than seven days

Orbiter heat rejection subsystem components not included in Orbiter baseline

Orbiter payload attachment fittings in excess of four

Adapter hardware for attaching the EVA airlock to the tunnel and Orbiter cargo bay.

TABLE 1.5

BASIC DATA BASE FILE

1. Launch year for desired grouping.
2. Weight per extended mission day to be added to FC Spacelab PL total - excluding crew provisions (WORB)
3. Any other data item that does not naturally fall in the other data base files.

Table 1.8
CRITERION CHARACTERISTICS

| Criterion | Packing Alternative ^(a) | Nature of Adaptability | Tolerance ^(b) |
|---------------------------------|---------------------------------------|---------------------------|--------------------------|
| Dedication | A | | |
| Mass | A | | |
| C.G. - Longitudinal | A, C ^(c) | | 20% |
| Orbit | | | |
| Altitude | A | | |
| Inclination | A | | |
| Volume-Area | | | |
| Gross Check | A | | 10% |
| Detailed ^(d) | A | | |
| Energy | A | | 25% |
| Continuous Power | A | | |
| Pointing | | | |
| RCS Fuel | A | | |
| IPS | A | | |
| g-Level | A | | |
| Continuous Thermal Rejection | A | | |
| Crew Attendance Time | | Add crewman, | |
| Time | A, D | Extend | 0% |
| Weight | A, D | Mission | |

(a) A - Rejection

C - Rearrangement

D - Adaptability

(b) Percentages are samples chosen for illustration purposes only.

(c) C.G. is the only criterion with the rearrangement alternative.

(d) As illustrated later this model is more complex, and is therefore tested only after a FC has reached a specified level of loading.

Table 1.9

ORDERED CRITERIA (LOGIC FLOW STRUCTURE)
LOADING PAYLOADS ONTO FLIGHT CONFIGURATIONS

| Alternatives | Criterion |
|--------------|---|
| A | Pointing - IPS ^(a) . |
| | Dedication |
| | Mass |
| | Orbit |
| | Volume - Area Check |
| | Continuous Power |
| | Pointing - RCS Fuel |
| | g-Level |
| | Continuous Thermal Rejection |
| A, C | C.G. - Longitudinal |
| A, D | Energy |
| | Crew Attendance Time - Time - Weight |

(a) Since IPS Model modifies PL characteristics which other criteria check, IPS criterion is first (see Table 3)

Table 1.10
CRITERION MODEL DEFINITION

| Criterion Index | Criterion | Model Type | | | Alternatives Other Than Reject (A) and Nature | Maximum Tolerance* |
|-----------------|------------------------------|------------|-----------------|------------------------|---|--------------------|
| | | Additive | Parameter Match | Other | | |
| 1 | Dedication | | ✓ | | | |
| 2 | Mass | ✓ | | | | |
| 3 | C. G. | | | Rearrangement | | 20% |
| 4 | Orbit Altitude inclination | | | Orbit Parameter Test | | |
| 5 | Volume Area Gross Check | ✓ | | Arrangement | | 10% |
| 6 | Detailed | | | | | |
| 7 | Energy | ✓ | | | | 25% |
| 8 | Continuous Power | ✓ | | | | |
| 9 | Pointing RCS Fuel | | | Added Weight | | |
| 10 | IPS | | | IPS Model | | |
| 11 | g-Level | | | g-Level | | |
| 12 | Continuous Thermal Rejection | ✓ | | | | |
| 13 | Crew Attendance Time | | | Attendance Time-Weight | | 0% |
| 14 | Weight | ✓ | | | | |

*Percentages are samples chosen for illustrative purposes only.

Table 2.3.1
DEDICATION SPLIT BY RESOURCE PERCENTAGE WITHIN OFFICE

Office i_1 ($X_j\%$) / Office i_2 ($Y_j\%$)

Where j = Resource Criteria

- j = 1 Weight
- 2 Volume
- 3 Energy
- 4 Orbit
- 5 Discipline
- 6 Others

$$X\% + Y\% = 100\%$$

Table 2.3.7
DEDICATION SPLIT BY OFFICES

Office (i_1) / Office (i_2)

Where i_n = NASA Office A
B
C
D
.
.
n (Default)

Multiuser
ESA
None

Table 7.3.9
SAMPLE PAYLOAD RESOURCE TABLE*

| Unordered Payloads | Additive Criteria - Percentage Usage of Available (No Tolerance) With Factors* | | | Etc. | Total |
|--------------------|--|--------------|---------------|------|-------|
| | Energy x EF | Mass x MF | Crewtime x CF | | |
| 1 | 20 x EF = 24 | 20 x MF = 22 | 5 x CF = 5 | | 51 |
| 2 | 90 x EF = 108 | 10 x MF = 11 | 10 x CF = 10 | | 129 |
| 3 | 50 x EF = 60 | 50 x MF = 55 | 50 x CF = 50 | | 165 |
| 4 | 40 x EF = 48 | 10 x MF = 11 | 5 x CF = 5 | | 64 |

Sample Factors: EF = 1.2
MF = 1.1
CF = 1.0

Table 7.4
SAMPLE ORDERED PAYLOAD MANIFEST

| Total% | Payload |
|--------|---------|
| 165 | 3 |
| 129 | 2 |
| 64 | 4 |
| 51 | 1 |

*Table should include all additive criteria.

Note: Numbers are samples chosen for illustrative purposes only.

TABLE 7.22
 SAMPLE POWER INFORMATION MANIFEST

| <u>FC INDEX</u> | <u>FC TYPE</u> | <u>PL ID</u> | <u>OPERATING POWER (KW)</u> | <u>OPERATING DURATION (HR/OPERATION)</u> | <u>FREQUENCY OF OPERATION (TIMES/DAY)</u> | <u>MISSION DURATION (DAYS)</u> | <u>TOTAL POWER KW-HR</u> |
|-----------------|----------------|--------------|-----------------------------|--|---|--------------------------------|--------------------------|
| 1 | 2 | 0A-1 | 0.05 | 1 | 2 | 7 | 0.70 |
| | | 0A-3 | 0.02 | .5 | 2 | 7 | 0.14 |
| | | 0A-5 | 0.08 | .2 | 4 | 7 | 0.45 |
| | | 0A-7 | 0.05 | 1.5 | 1 | 7 | 0.52 |
| | | 0A-10 | 0.01 | 2 | 2 | 7 | 0.28 |
| | | 0A-12 | 0.02 | 1 | 3 | 7 | 0.42 |
| | | 0A-15 | 0.10 | 1 | 2 | 7 | 1.4 |
| | | | | | | | <u>3.91 KW-HR</u> |

Table 8
SAMPLE OUTPUT MANIFEST

Launch Interval: 1/85 - 1/86
Tolerance Level: 5%^(a)
Number PL: 10
Number APL: 3

Total Number of FC's = 3
Number of

Date: 6/20/78
Time: 10:20
Operator: X. Smith

| FC Index | FC Type ^(b) | APL | Range (Inclination) | Dedication | Crew No. | Duration ^(d) | Mass (Mg.) | LCG ^(c) (m) | MDE | Adapters Required | Percentage of Available Resources Used for Additive Criteria ^(d) | | | | |
|----------|------------------------|------|------------------------|------------|----------|-------------------------|------------|---------------------------|---------------------|----------------------|--|---------------|---------------------------|-------|------|
| | | | | | | | | | | | Energy | Crew- time | Thermal Rejec- tion | Power | Etc. |
| 1 | 3 | - | KSC (40) | NASA | 5 | 7 | 10.5 | 19.5 | - | - | 105 | 30 | 25 | 95 | . |
| 2 | 6 | 2 | VAFB (82) | - | 7 | 7 | 23.1 | 22.5 | - | OMS | 90 | 60 | 50 | 80 | . |
| 3 | 2 | 1, 3 | KSC (-) | - | 6 | 7 | 9.0 | 23.0 | Man. ^(e) | EPS | 40 | 105 | 20 | 30 | . |

Note: All numbers are samples chosen for illustrative purposes only

- (a) 105% maximum (of nominal)
- (b) Appendix I
- (c) LCG: Forward end of orbiter cargo bay is located at 10m.
- (d) Table should include all additive criteria for Level II.
- (e) Man. - Manipulator

MCDONNELL DOUGLAS

Table 9
SAMPLE FC WEIGHT SUMMARY

Launch Interval: 1/85 - 1/86
Tolerance Level: 5%

Date: 6/20/76
Time: 10:20
Operator: X. Smith

Units: kg.

| FC Index | Mission Independent Orbiter Support | | SL Mission Independent | | MDE | | SL PL (Experiments and Crew - APL not included) | | APL | | Total | |
|----------|-------------------------------------|-----|------------------------|-------|-------|-------|---|--------|-------|---|--------|--------|
| | L | R | L | R | L | R | L | R | L | R | L | R |
| 1 | 1,200 | 800 | 4,700 | 4,700 | 1,200 | 1,200 | 3,400 | 3,400 | 0 | 0 | 10,500 | 10,100 |
| 2 | 1,000 | 700 | 5,200 | 5,200 | 1,000 | 1,000 | 13,000 | 12,900 | 2,900 | 0 | 23,100 | 19,800 |
| 3 | 1,000 | 900 | 4,000 | 4,000 | 1,000 | 1,000 | 1,200 | 1,100 | 1,800 | 0 | 9,000 | 7,000 |

Note: All numbers are samples chosen for illustrative purposes only.

L - Launch

R - Reentry

TABLE 10
CONFIGURATIONS

| | <u>SPACELAB CONFIGURATION TYPES</u> | <u>CONFIGURATION ORDERING FOR GROUPING PROCESS</u> |
|---|---|--|
| | | 2 |
| 1 |  | 7 |
| | | 8 |
| 2 |  | 6 |
| | | 5 |
| 3 |  | 3 |
| | | 4 |
| 4 |  | 1 |
| | | |
| 5 |  | |
| | | |
| 6 |  | |
| | | |
| 7 |  | |
| | | |
| 8 |  | |

Table 11
COMPUTER FILES

| File | Source (Figure) | Source (Table) |
|--------------------------------|--------------------|-------------------|
| PL Model | 1.0 | |
| PL Data Base | 1.0 | |
| Orbiter Data Base | 1.0 | |
| Spacelab Data Base | 1.0 | |
| Ordered Criterion | | 1.9 |
| Criterion Model Definition | 1.0 | 1.10 |
| Payload Resource Table | 7.3 | 7.3.9 |
| Ordered Element List | 7.3 | 7.3.9 |
| Ordered FC List | - | 10 |
| Output Manifest | 1.0 | 8, 9 |
| Incomplete Container Manifest* | 13.1 | |
| Redistribution Manifest* | 13.2 | |
| Volume - Area Loading | 24.0 | |
| Automated PL Model | 26.0 | |
| Automated PL Data Base | 26.0 | |
| . | . | . |
| . | . | . |
| . | . | . |

*Optional Files

Table 12
 INPUT DATA BASE REQUIREMENTS

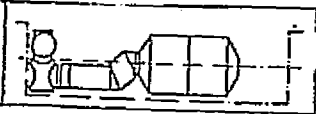
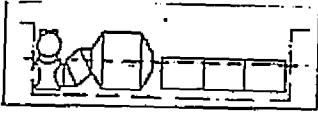
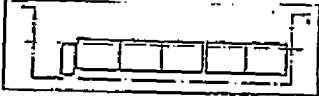
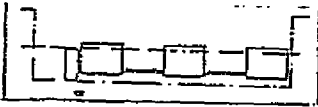
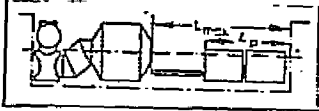
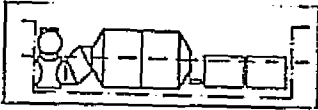
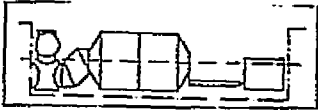
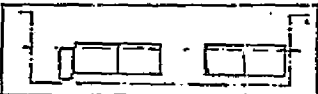
| Criterion | PL Data Base | | FC Data Base |
|------------------------------|-----------------------------|--------------------|------------------------------|
| | Amount of Resource Required | Parameter Required | Amount of Resource Available |
| Dedication | | ✓ | |
| Mass | ✓ | | ✓ |
| Orbit | | | |
| Altitude | ✓ | | |
| Inclination | | ✓ | |
| Volume-Area | | | |
| Gross | ✓ | | |
| Detailed | | | |
| Energy | ✓ | | ✓ |
| Power | ✓ | | ✓ |
| Pointing | | | |
| RCS Fuel | ✓ | | |
| IPS | | ✓ | |
| g-Level | | ✓ | |
| Continuous Thermal Rejection | ✓ | | ✓ |
| Crew Attendance | | | |
| Time | ✓ | | ✓ |
| Weight | | | ✓ |

TABLE 24.20

PALLET SECTION LAYOUT

| | | | | |
|-----|-----|------|------|------|
| 2,4 | 2,8 | 2,12 | 2,16 | 2,20 |
| 2,3 | 2,7 | 2,11 | 2,15 | 2,19 |
| 2,2 | 2,6 | 2,10 | 2,14 | 2,18 |
| 2,1 | 2,5 | 2,9 | 2,13 | 2,17 |

ABOVE MID-DECK

| | | | |
|--------------|------|-----|------|
| | 1,4 | 1,8 | 1,12 |
| | 1,3 | 1,7 | 1,11 |
| | 1,2 | 1,6 | 1,10 |
| ↑ LS ↓ | 1,1 | 1,5 | 1,9 |
| | ←WS→ | | |

BELOW MID-DECK

Table 26.1
 CRITERIA FOR AUTOMATED PAYLOADS

| Criterion | Model Type | | |
|-----------|------------|-----------------|--|
| | Additive | Parameter Match | Other |
| Weight | ✓ | | |
| Orbit | | ✓ | |
| Length | ✓ | | |
| C. G. | | | C. G. Calculation (Longitudinal) |

Table 26.2
 FC-PALLET ADDITION TABLE

| FC Type T | Can Add Pallet? | FC Changed to Type T |
|-----------|-----------------|----------------------|
| 1 | 1 | 7 |
| 2 | 0 | - |
| 3 | 0 | - |
| 4 | 1 | 8 |
| 5 | 1 | 2 |
| 6 | 0 | - |
| 7 | 1 | 6 |
| 8 | 1 | 3 |

Note that FC Type T=1 contains no pallets.

Table 27.2.1

SAMPLE LIST FOR CONTAINER (INITIALIZED TO ZERO)

| i | g_i^c | D_i^c |
|-----|---------------------|-----------|
| 1 | 10^{-7} g | 0 |
| 2 | 10^{-6} g | 0 |
| 3 | 10^{-5} g | 0 |
| 4 | 10^{-4} g | 8 hours |
| 5 | 10^{-3} g | 10 hours |
| 6 | 10^{-2} g | 100 hours |
| 7 | 10^{-1} g | 0 |

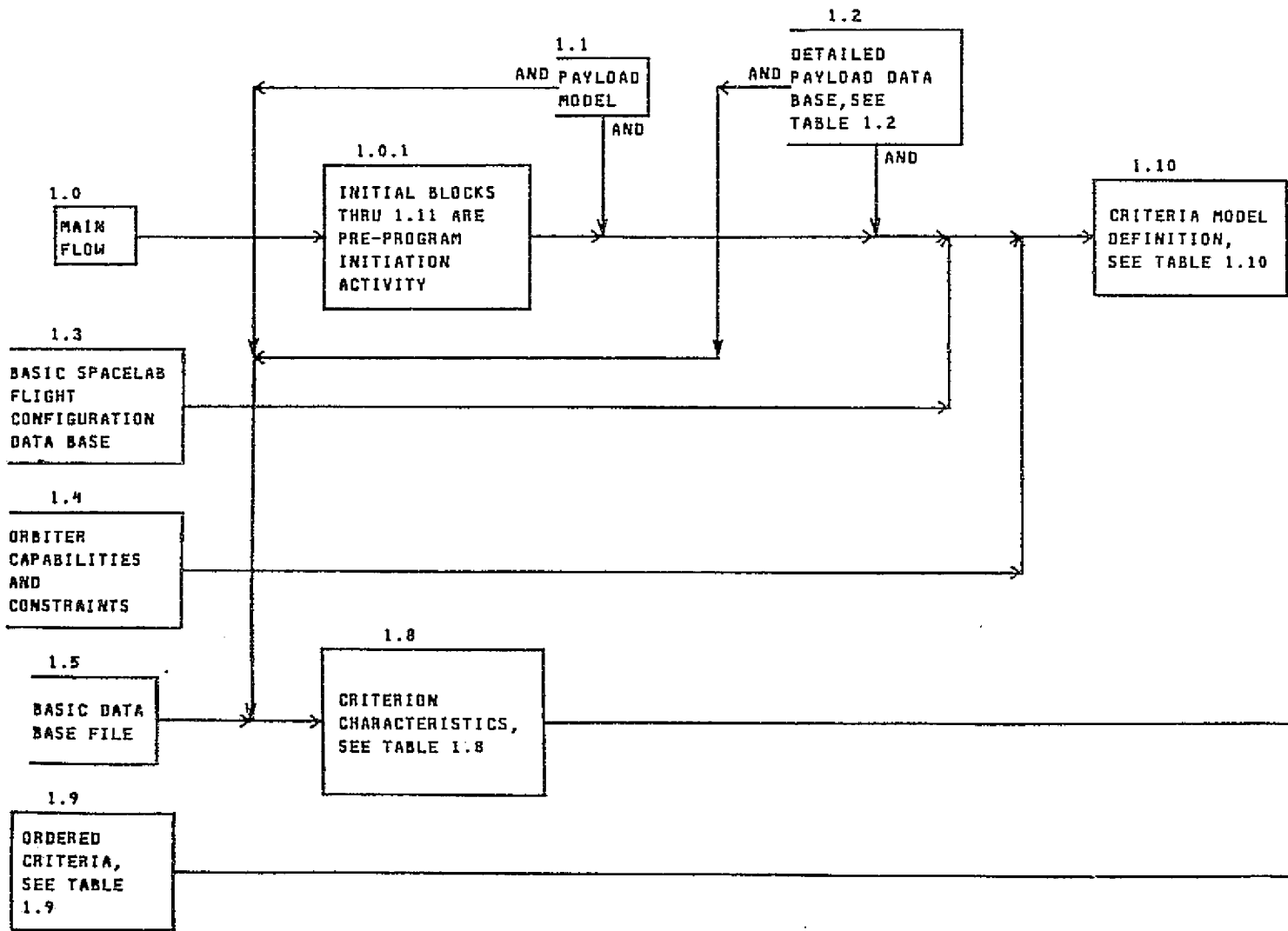

ORIGINAL PAGE IS
OF POOR QUALITY

FOLDOUT FRAME /

FIGURE 1.0

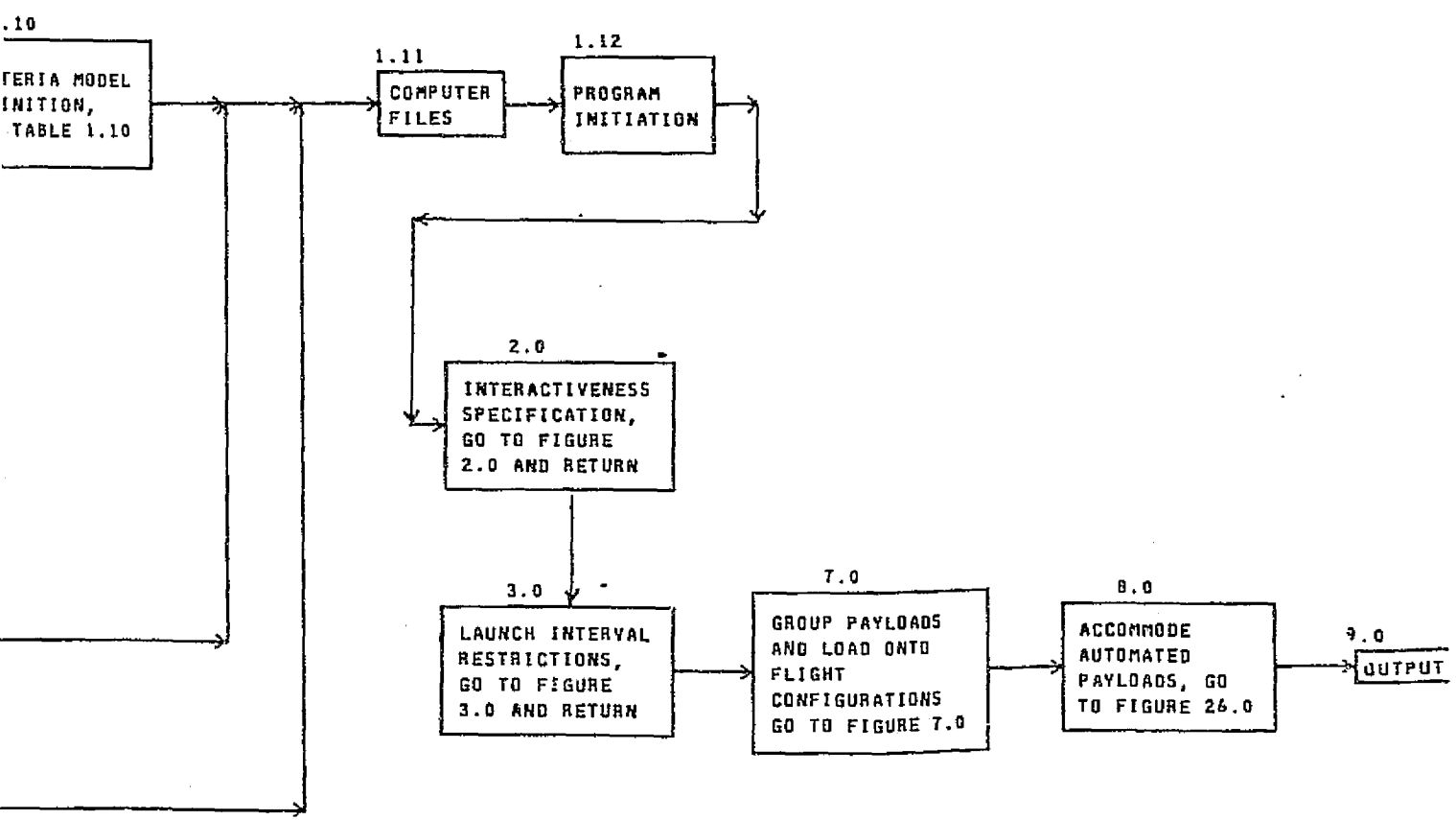

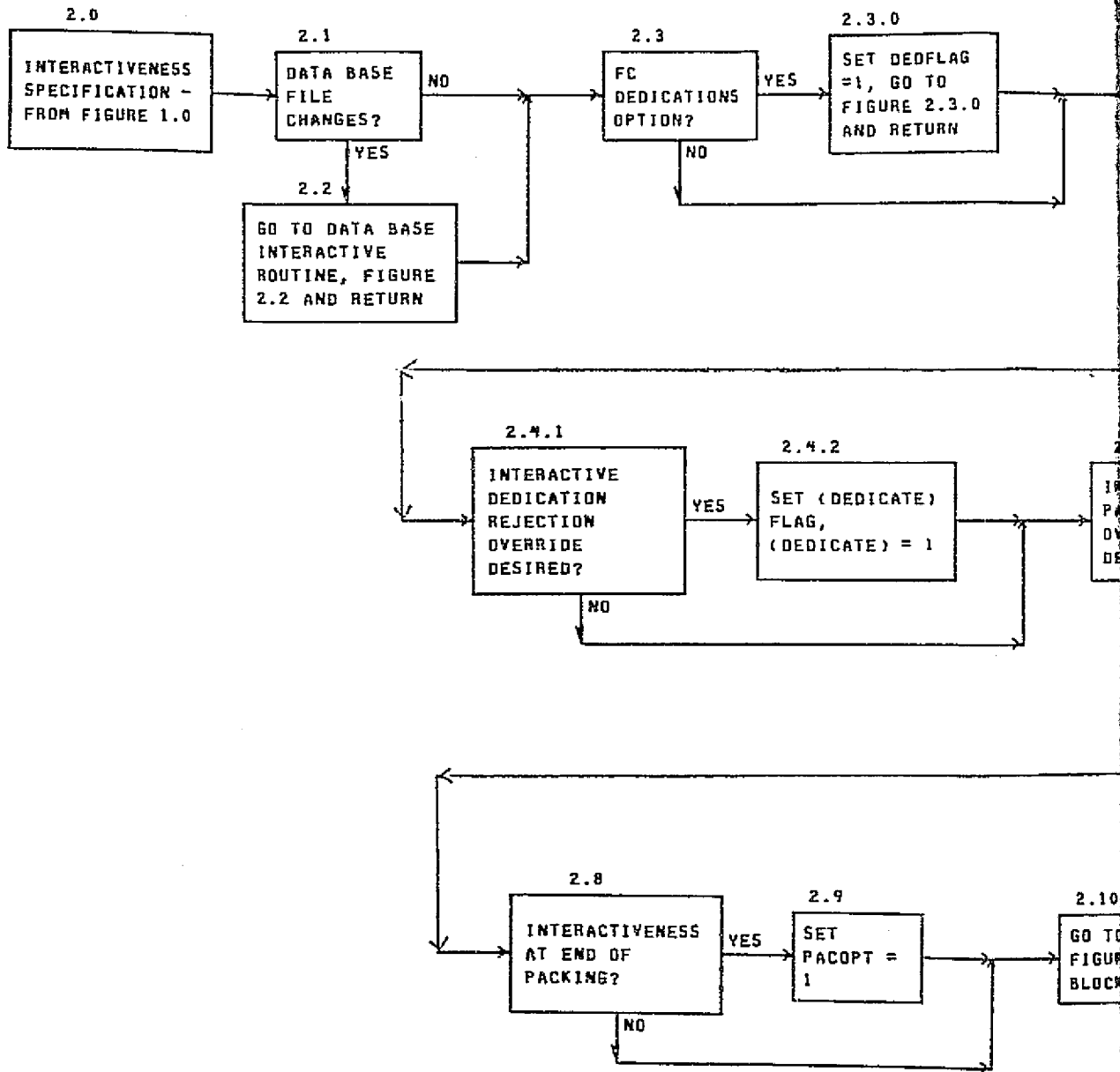

ORIGINAL PAGE IS
OF POOR QUALITY

FOLDOUT FRAME

FIGURE 2.0

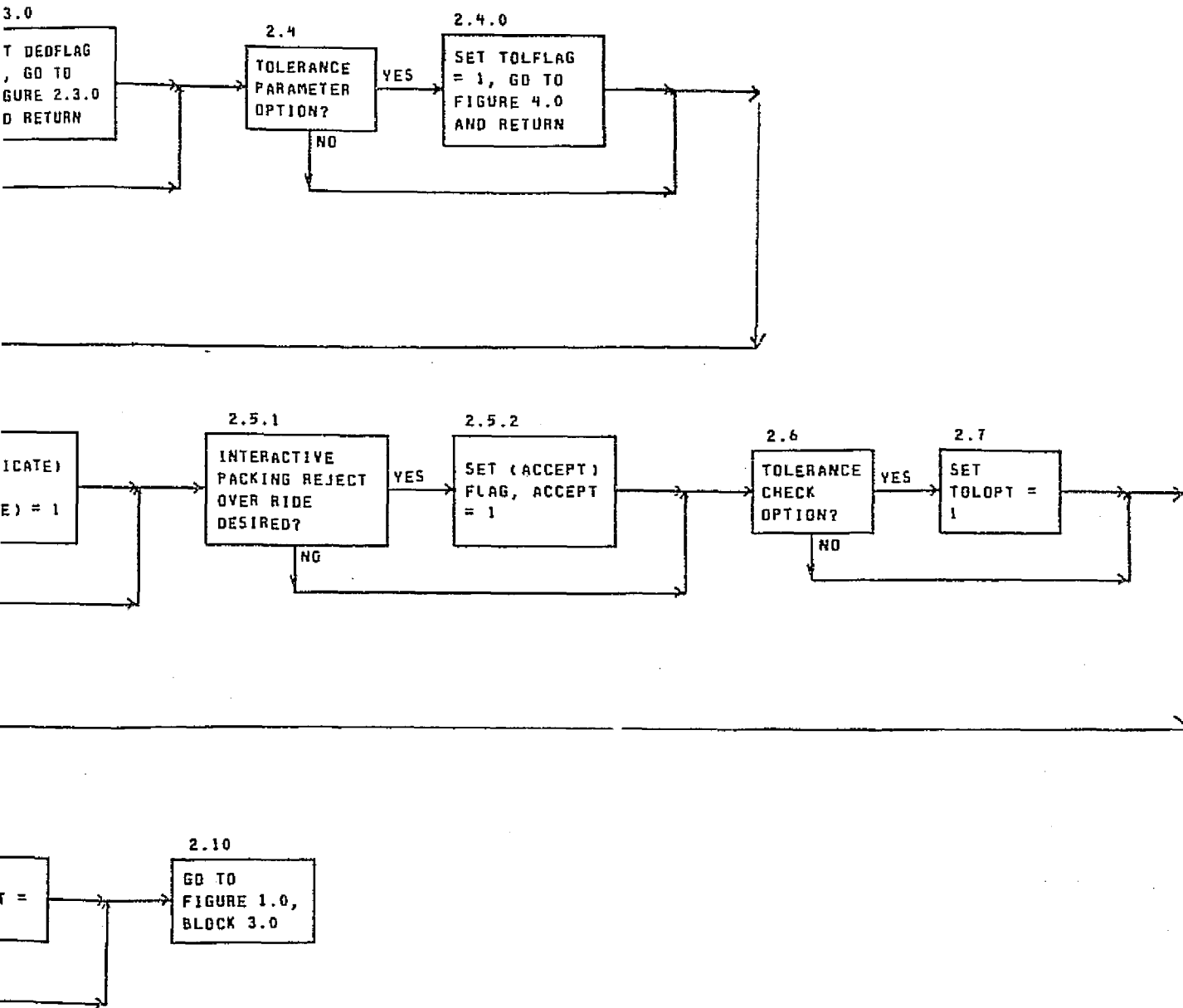

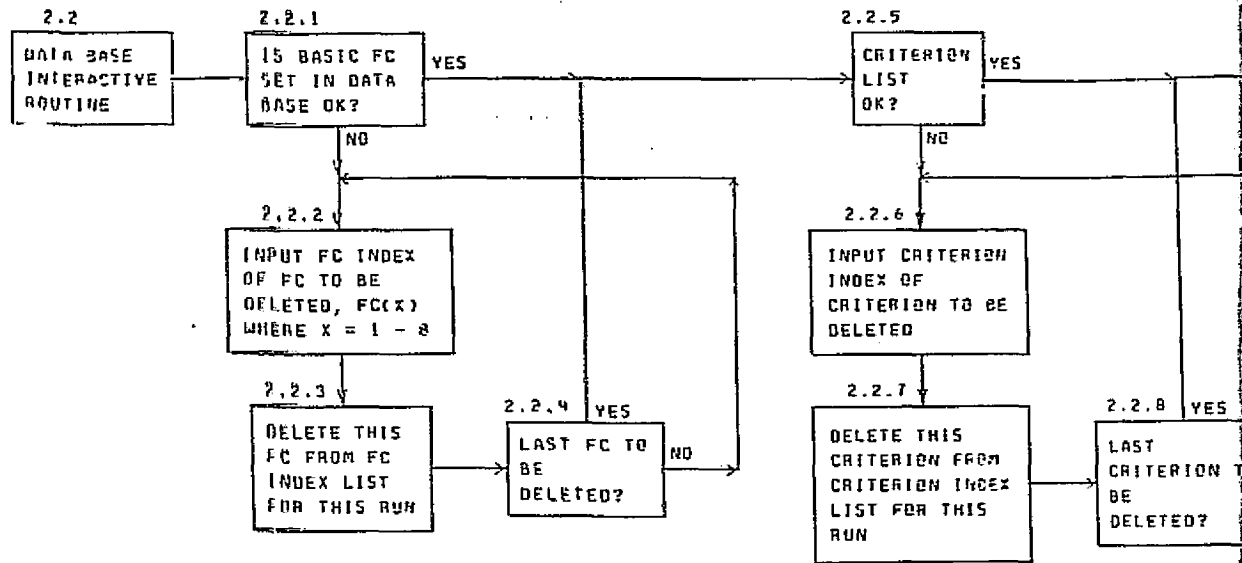

ORIGINAL PAGE IS
OF POOR QUALITY

FOLDOUT FRAME /

FIGURE 2.2

FIGURE 2.2

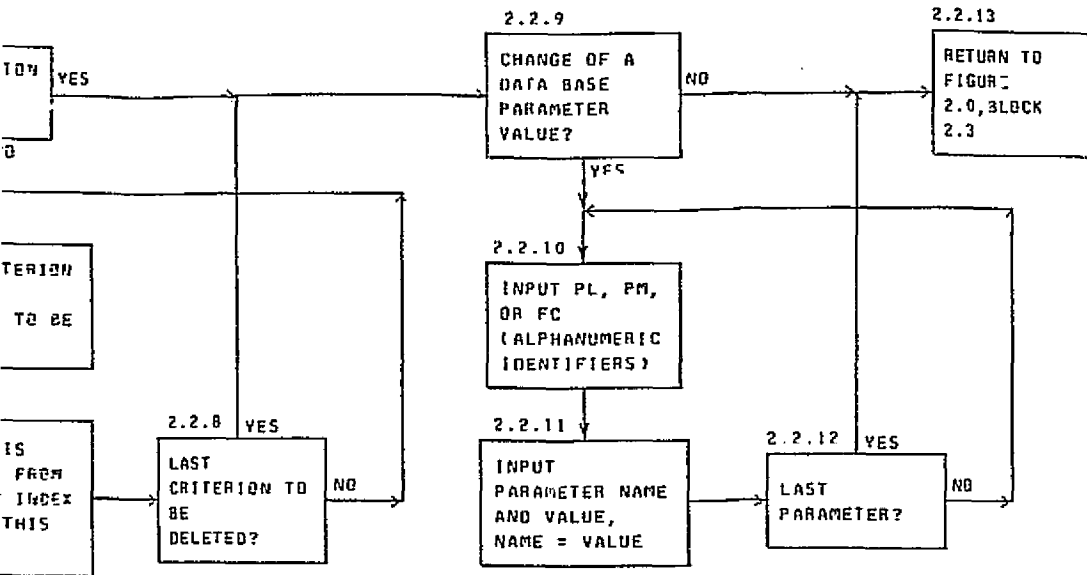

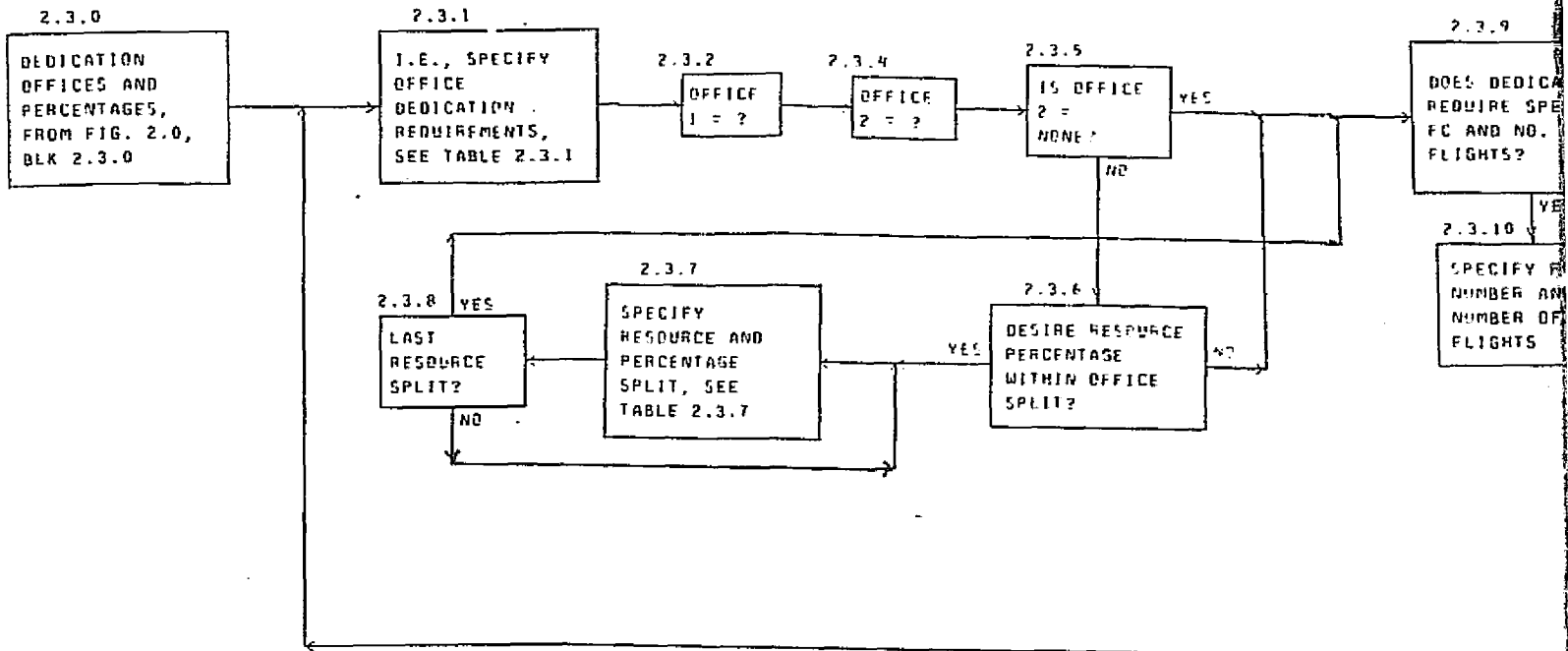

ORIGINAL PAGE IS
OF POOR QUALITY

FOLDOUT FRAME /

FIGURE 2.3

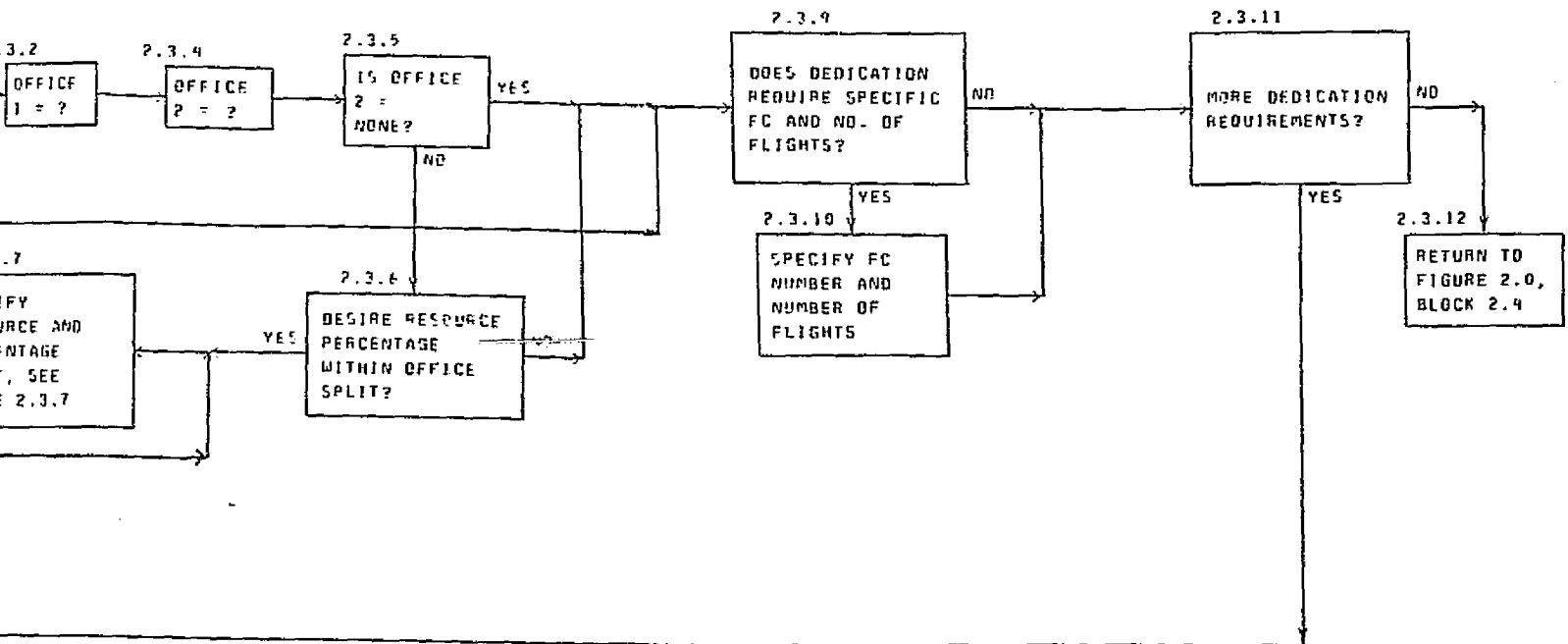

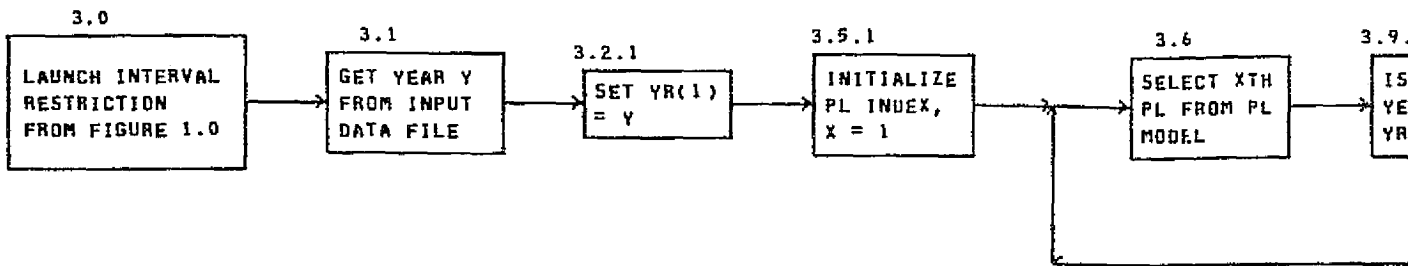

ORIGINAL PAGE IS
OF POOR QUALITY

MCDONNELL DOUGLAS FOLDOUT FRAME

FIGURE 3.0

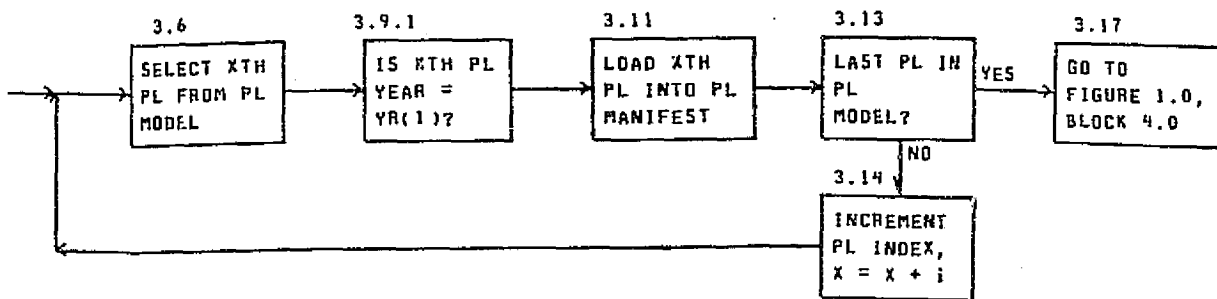

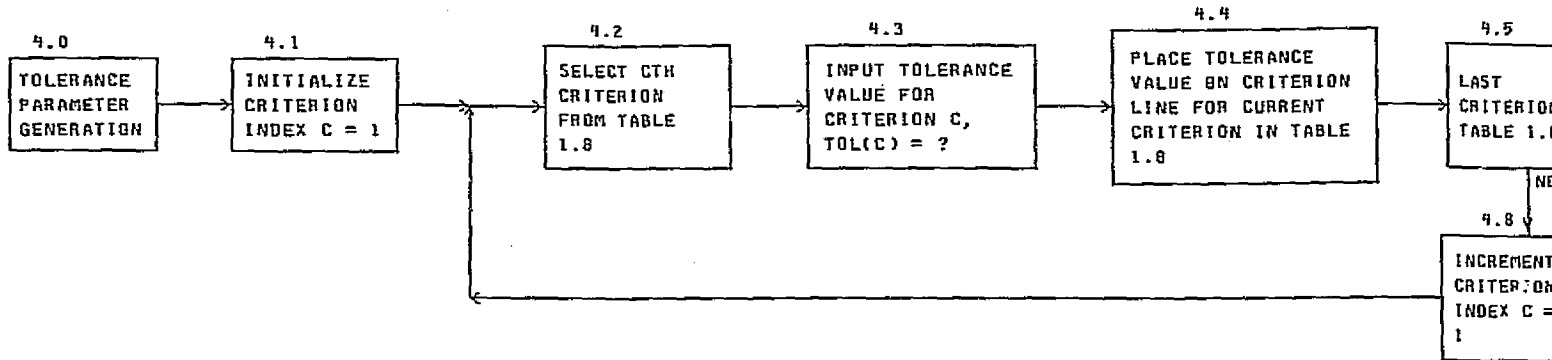

FOLDOUT FRAME

MCDONNELL DOUGLAS

FIGURE 4.0

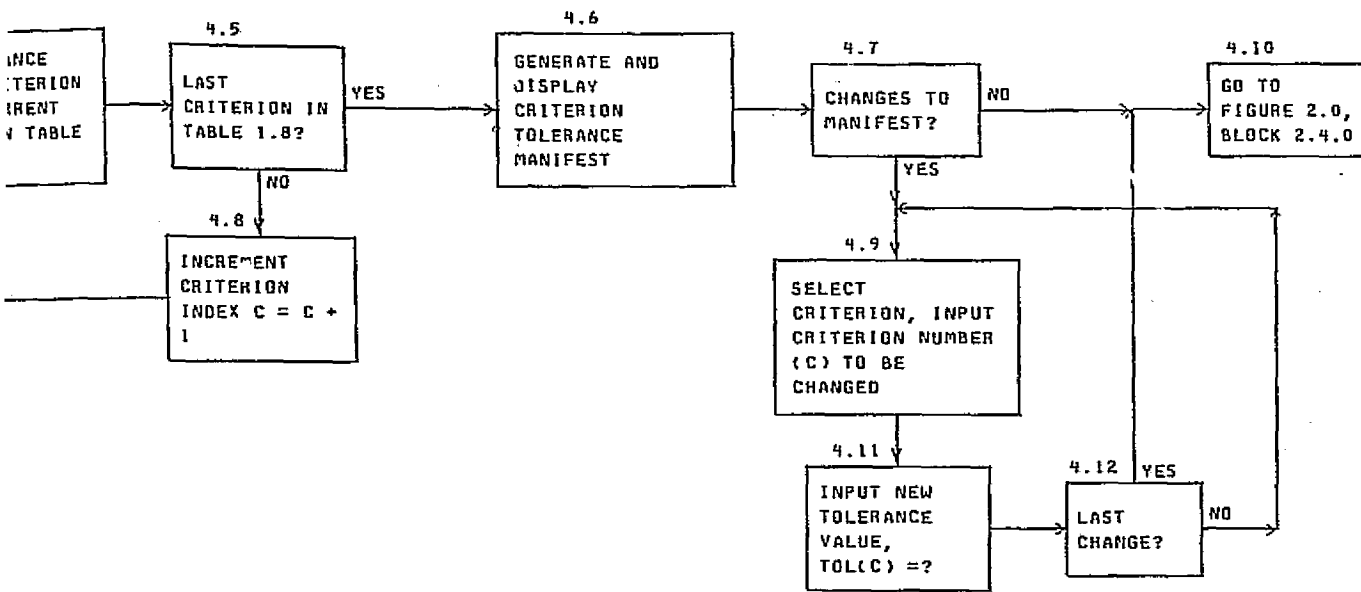

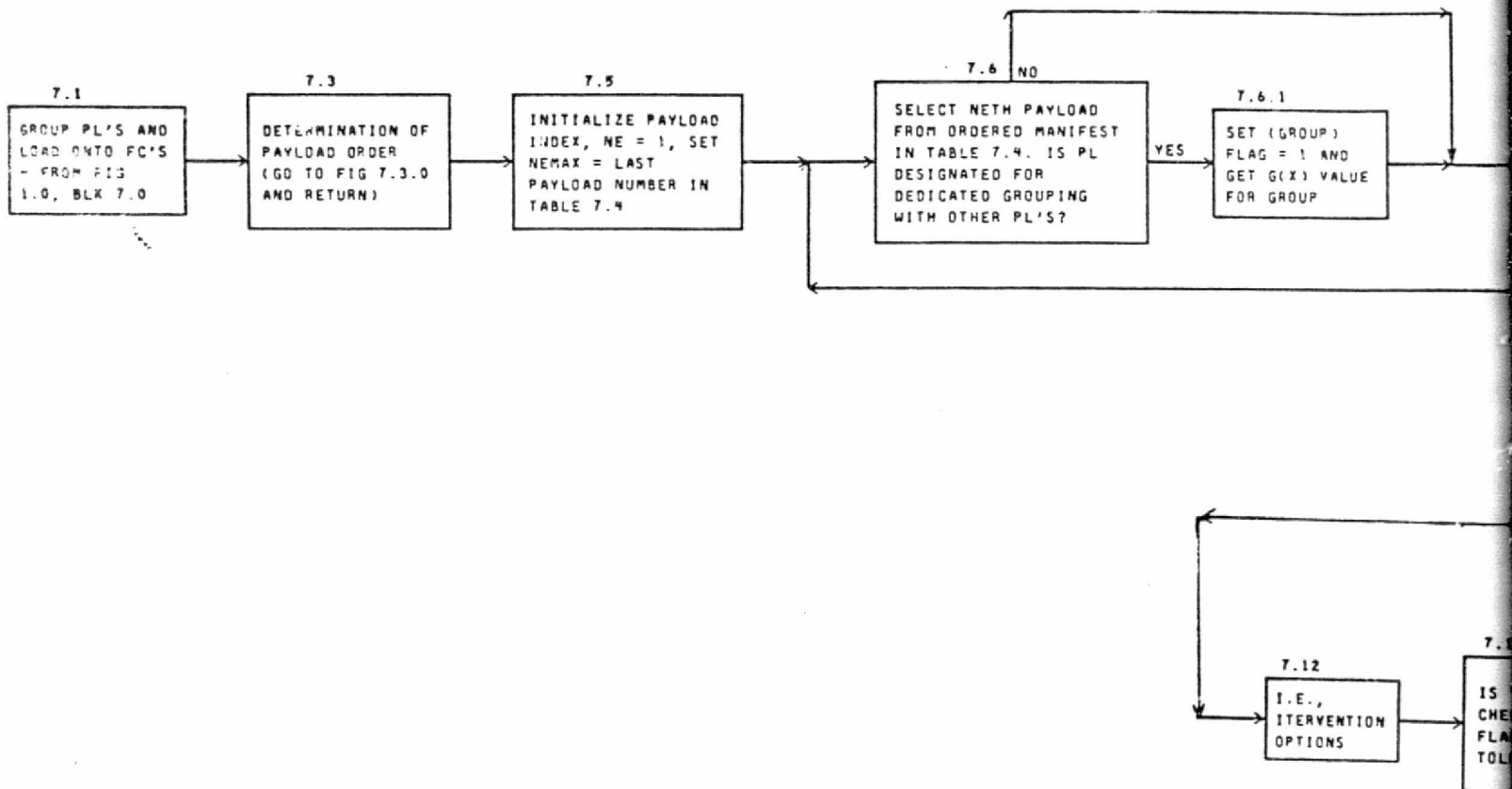

ORIGINAL PAGE IS
OF POOR QUALITY

FOLDOUT FRAME /

FIGURE 7.0

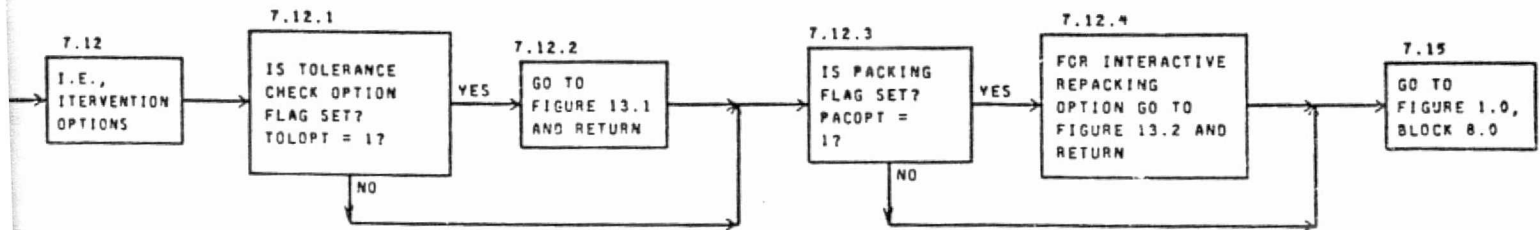
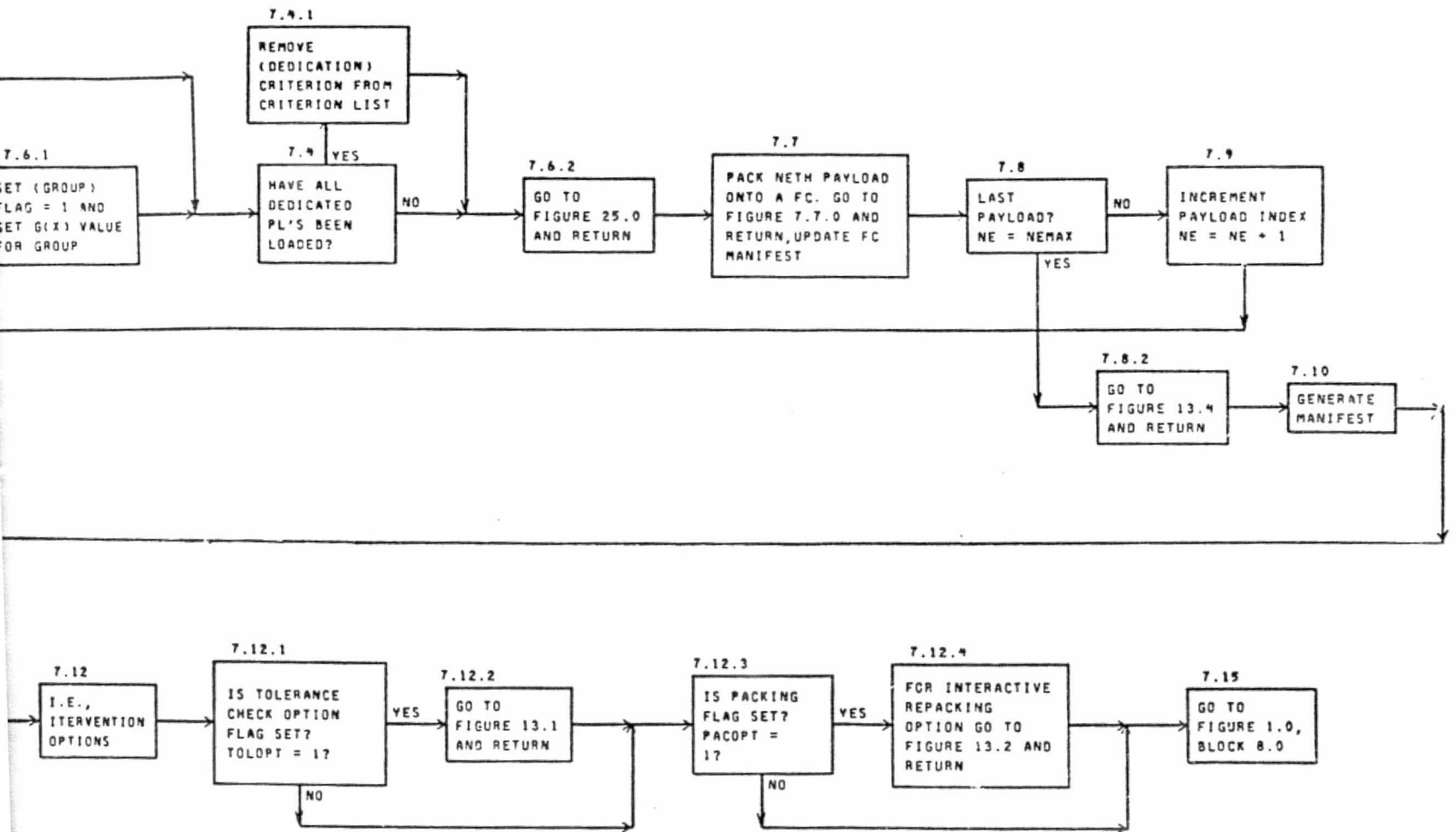

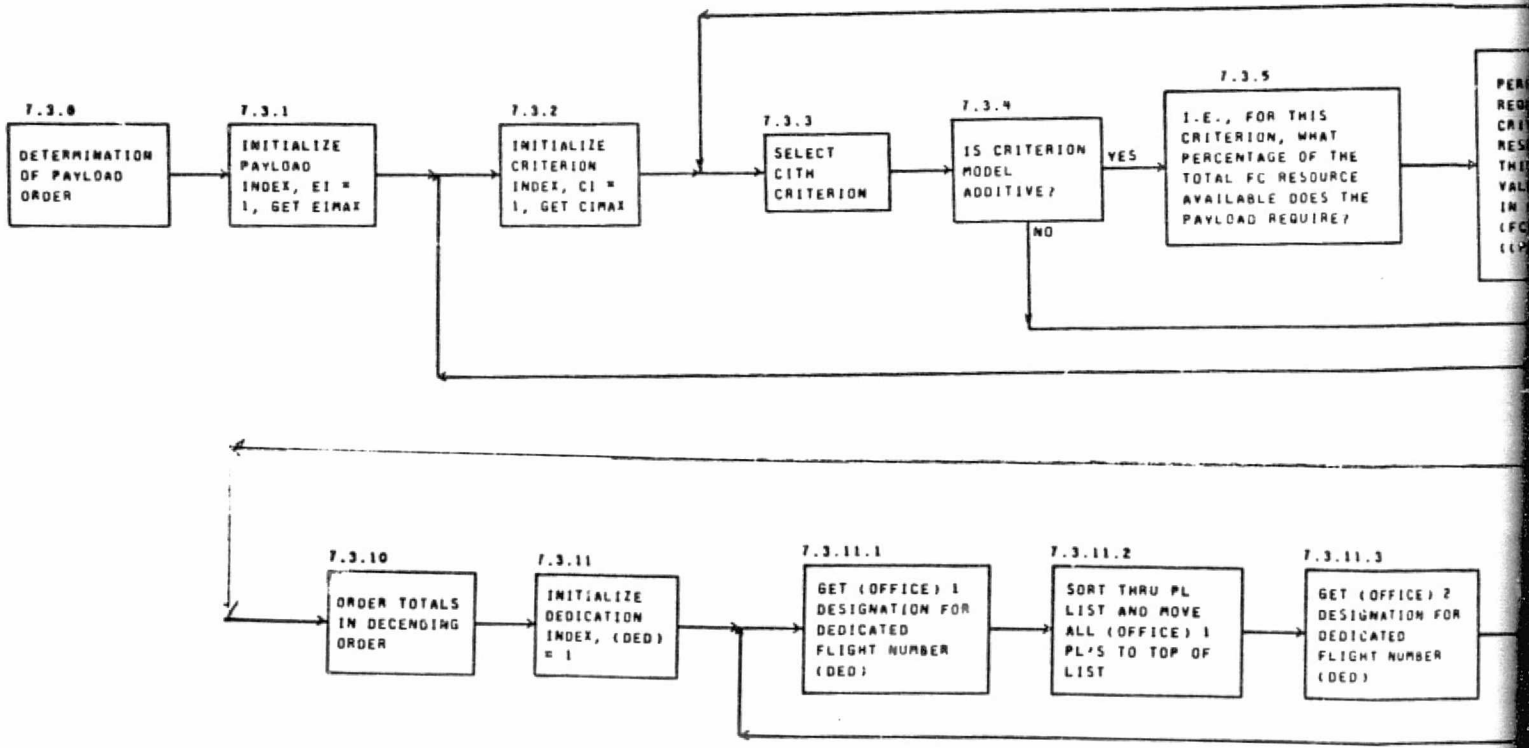

ORIGINAL PAGE IS
OF POOR QUALITY

FOLDOUT FRAME

FIGURE 7.3

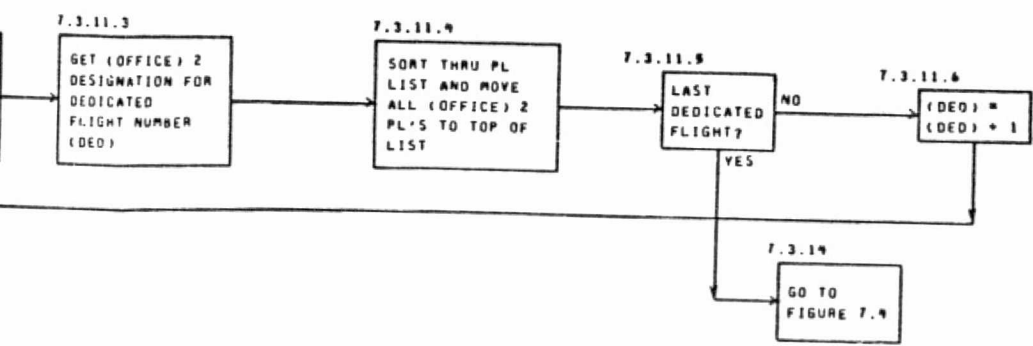
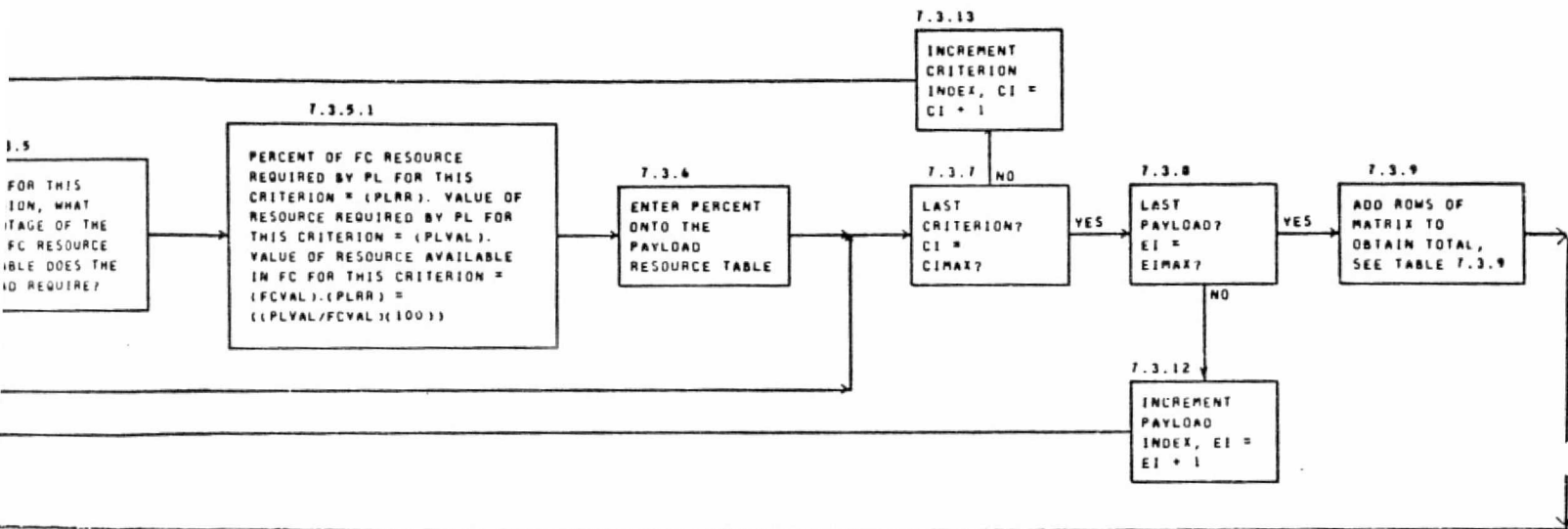

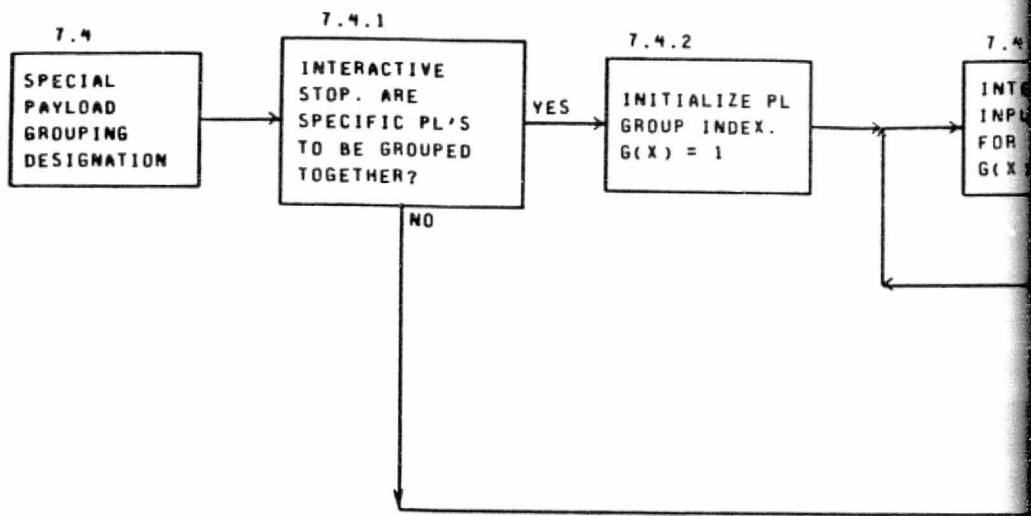

ORIGINAL PAGE IS
OF POOR QUALITY

FOLDOUT FRAME /

FIGURE 7.4

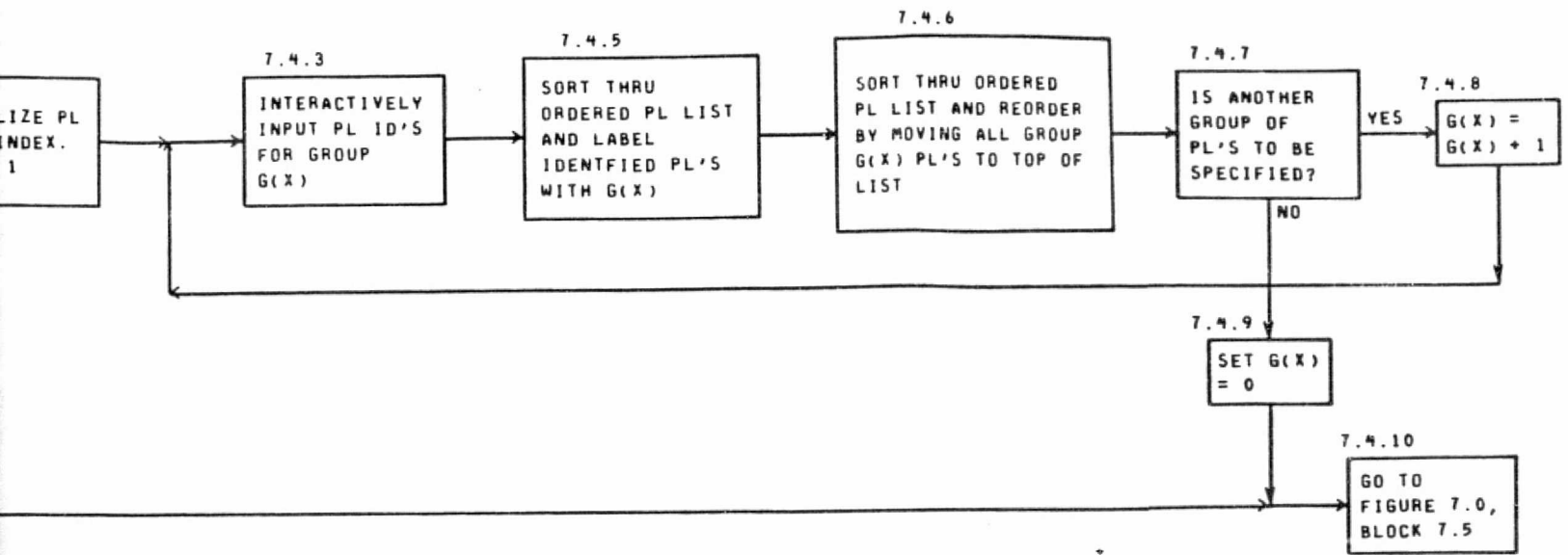

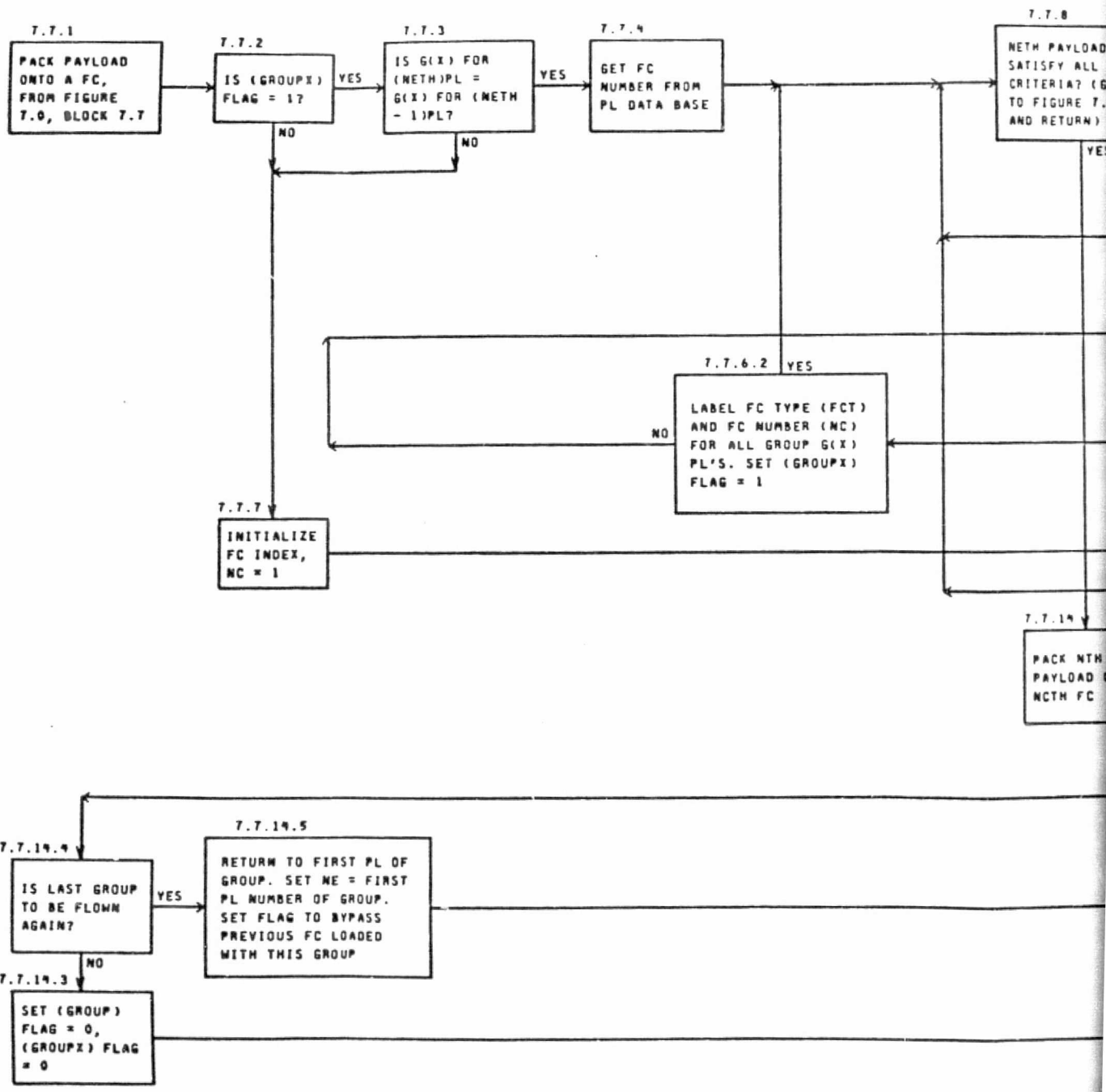

FOLDOUT FRAME /

FIGURE 7.7

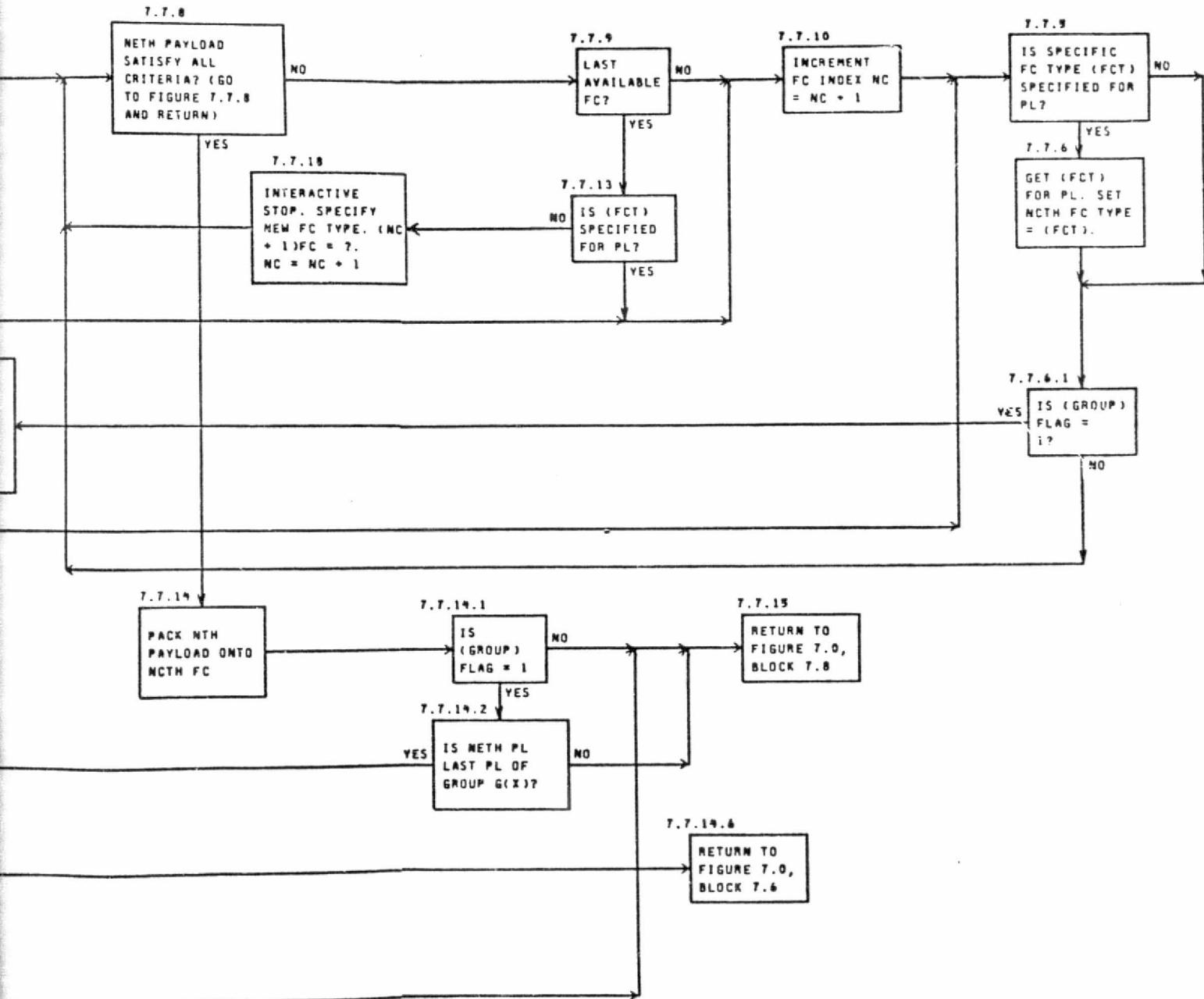

FOLDOUT FRAME 2

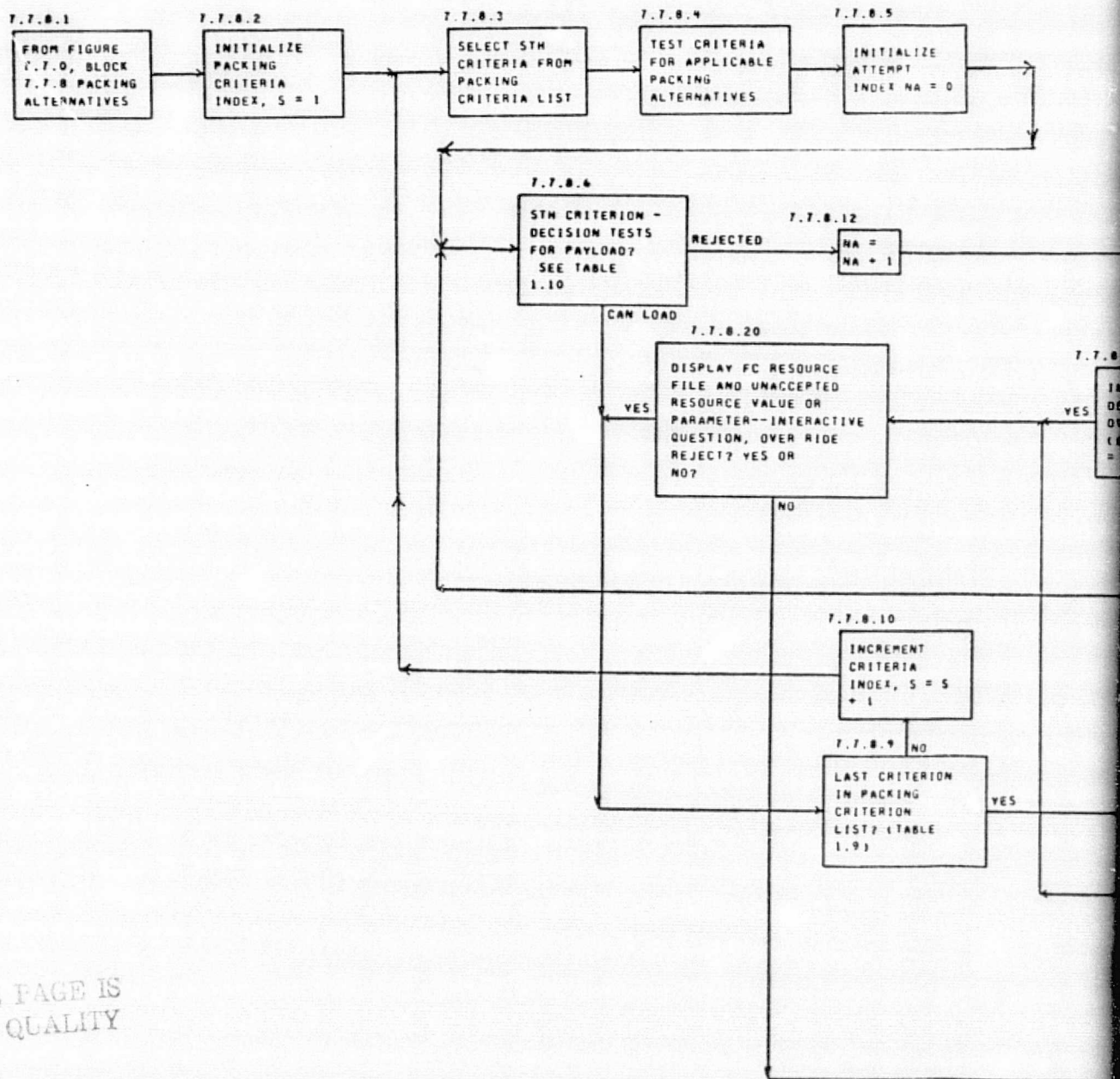

ORIGINAL PAGE IS
OF POOR QUALITY

FOLDOUT FRAME /

FIGURE 7.7.8

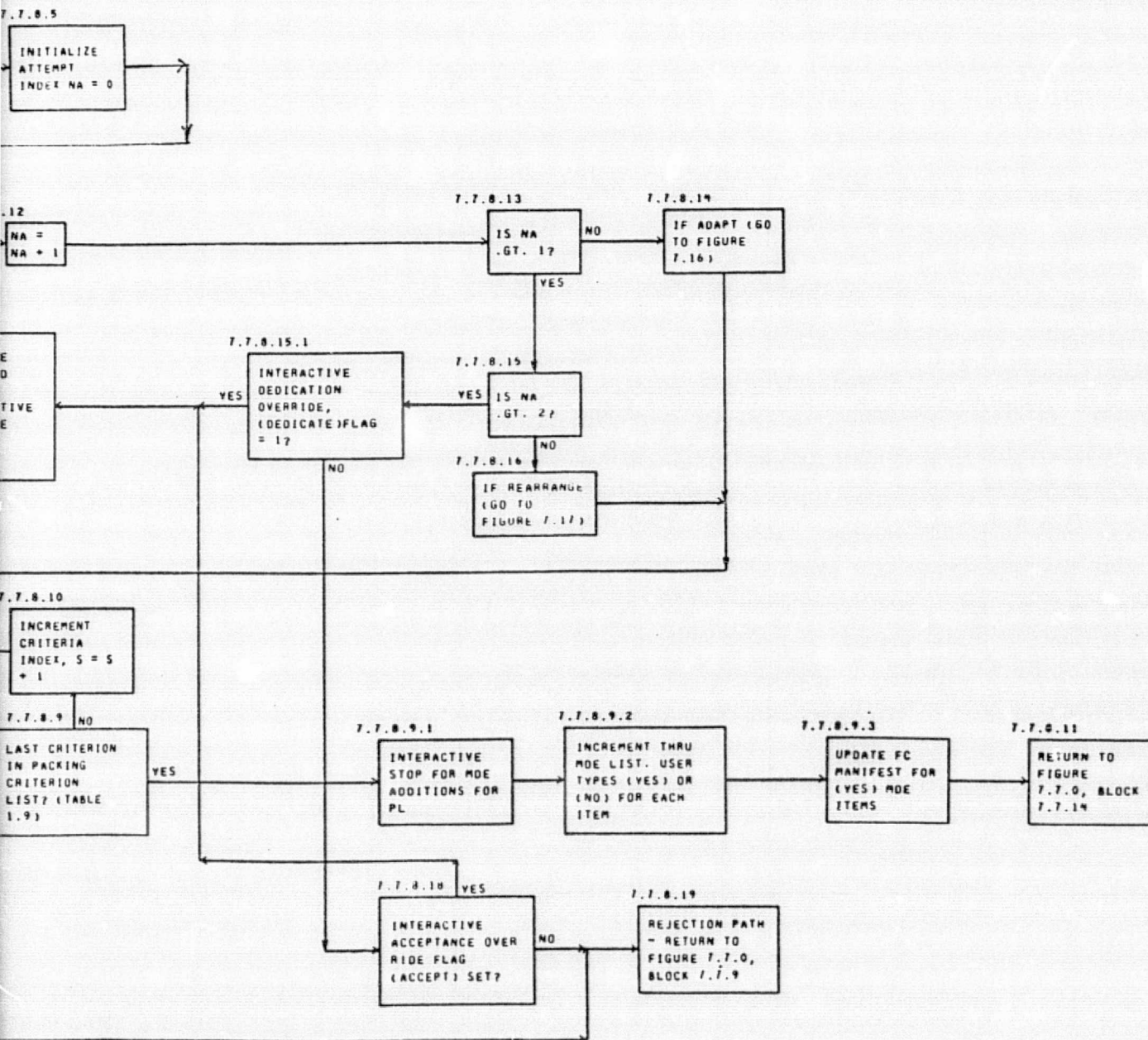

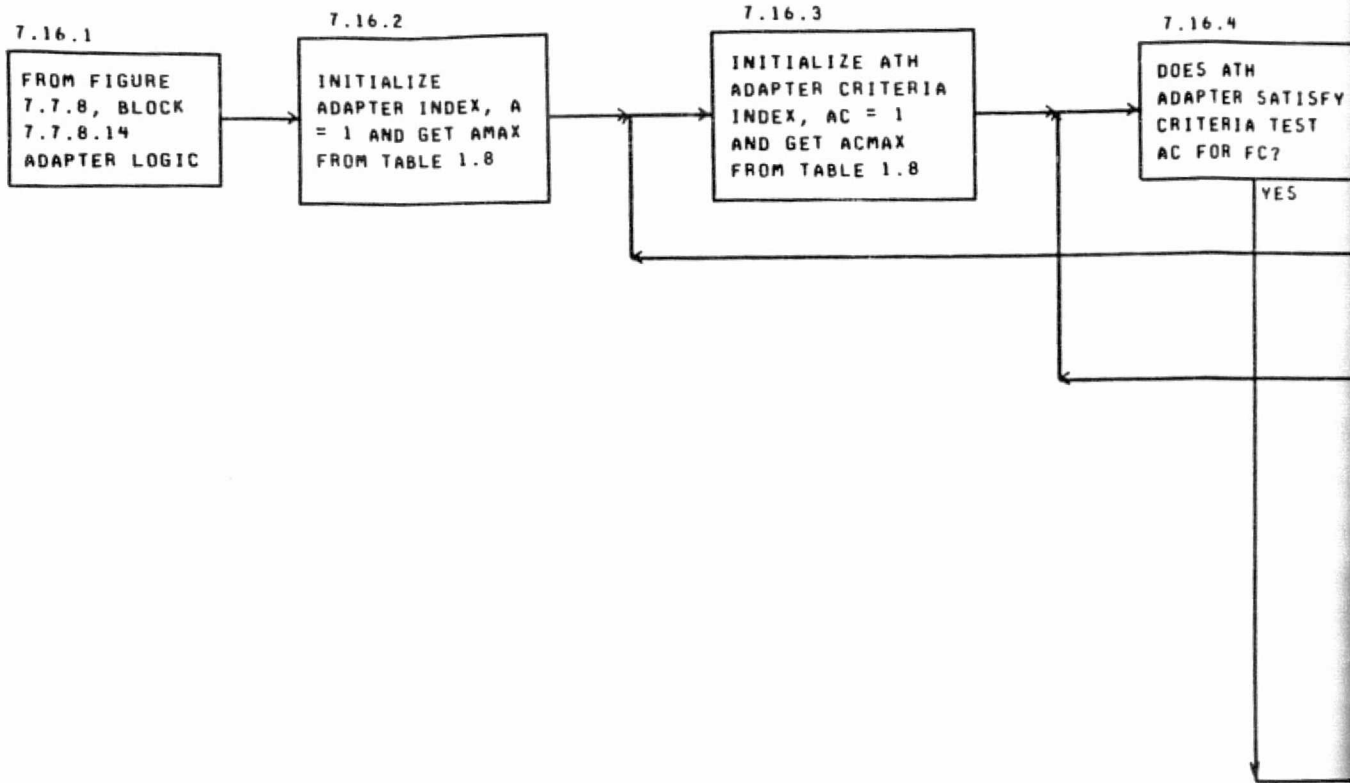

FOLDOUT FRAME)

FIGURE 7.16

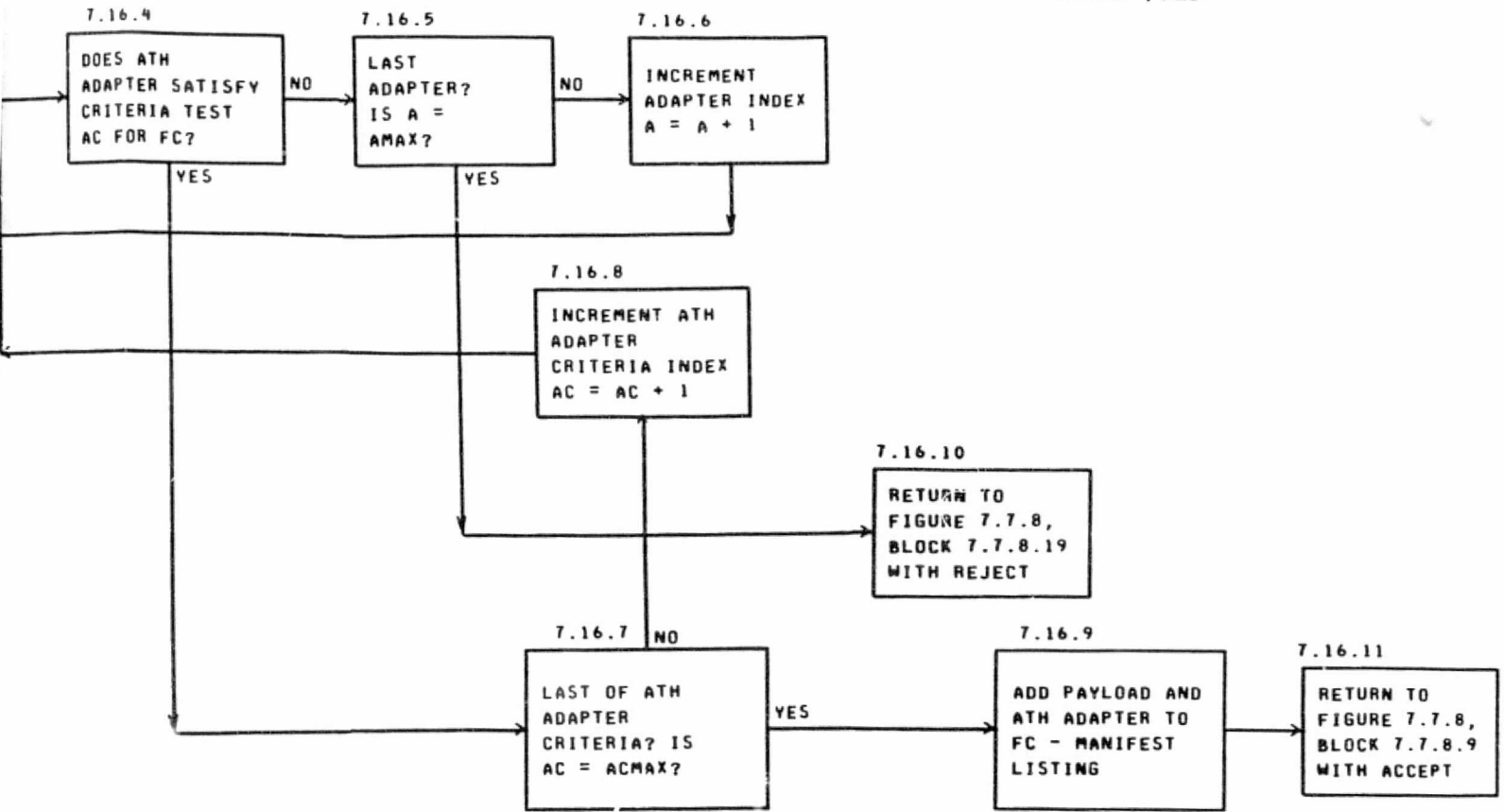

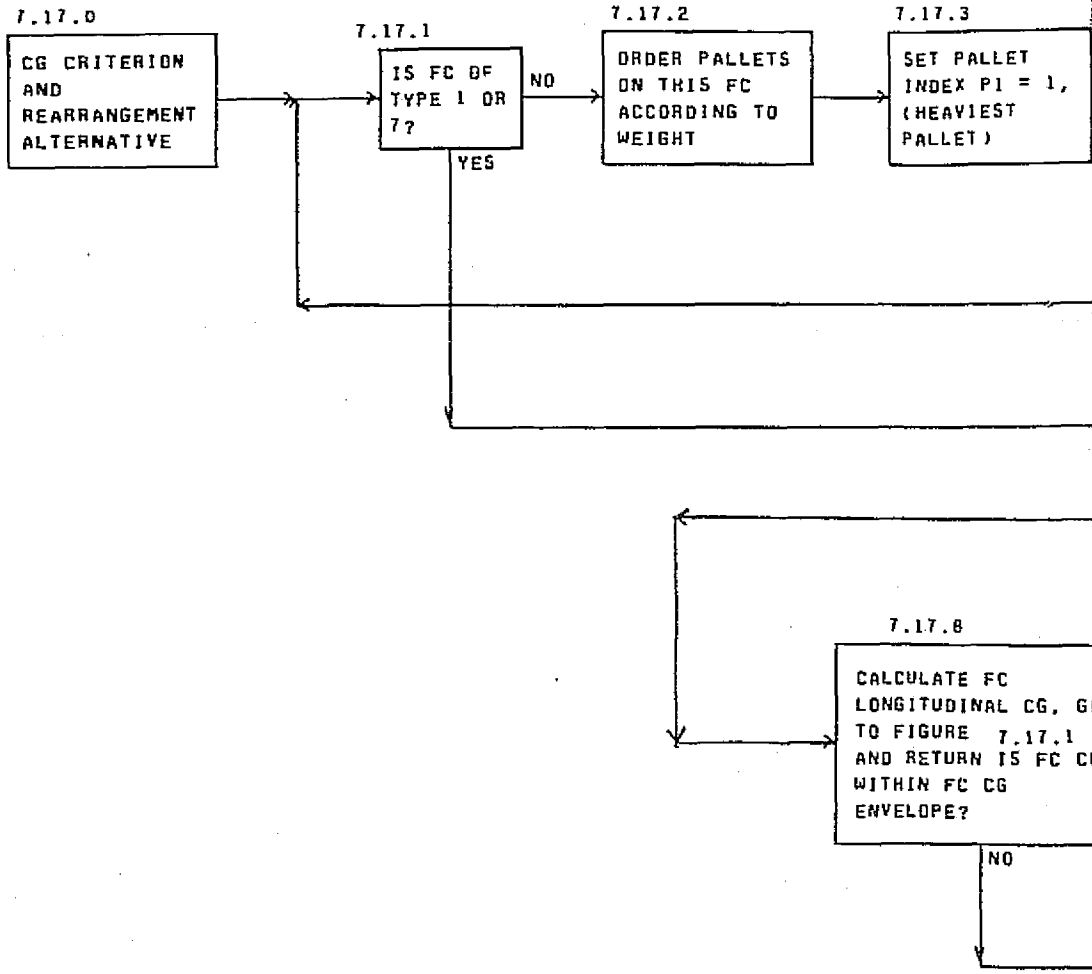

FOLDOUT FRAME

ORIGINAL PAGE IS
OF POOR QUALITY

FIGURE 7.17

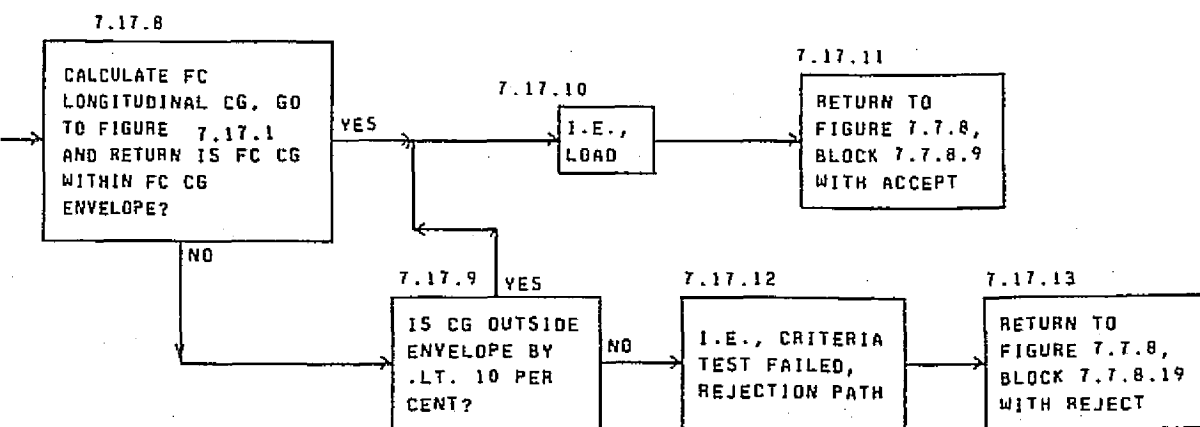
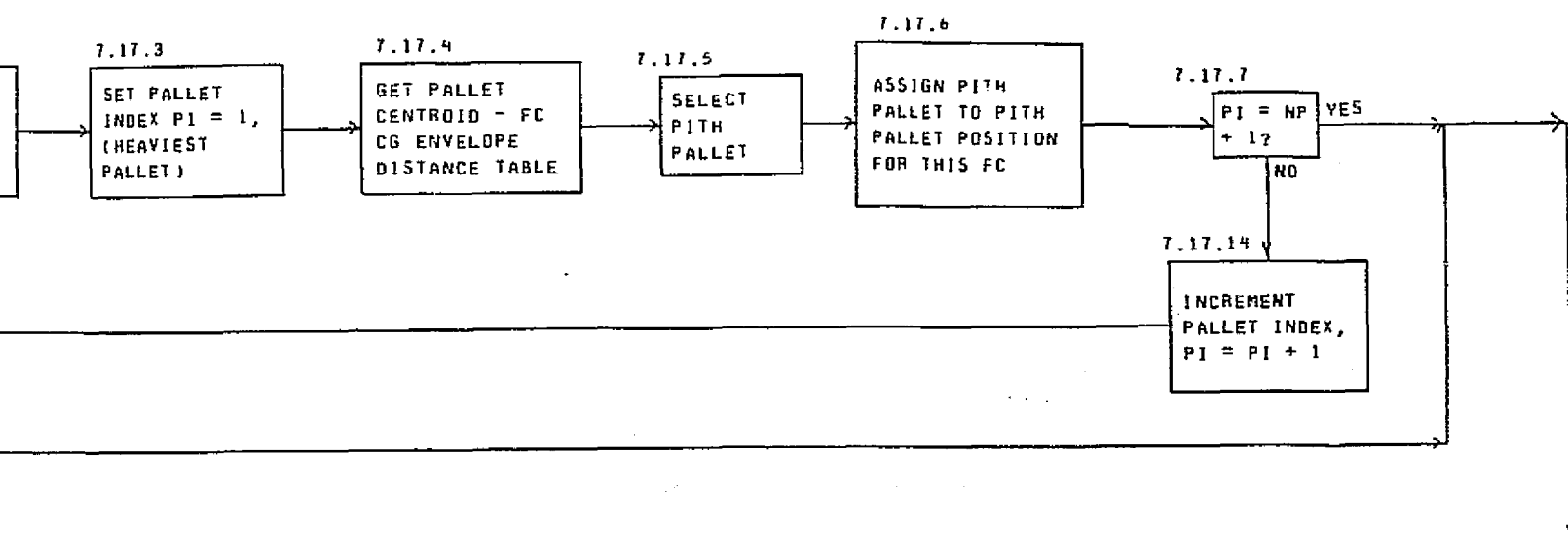

7.17.1.0

CALCULATE LONGITUDINAL CG, SEE TABLE 7.17.1 FOR DEFINITION OF SYMBOLS

7.17.1.1

IS LEVEL FLAG = 1

YES

NO

7.17.1.2

$$m_{ij} = \sum_{k=1}^{N_{ij}^{PL}} m_{ijk}^{PL} + m_{ij}^0$$

7.17.1.3

$$X_{ij} = m_{ij}^{-1} \left\{ \begin{array}{l} m_{ijA}^{PL} X_{ijk}^{PL} + \\ m_{ij}^0 X_{ij}^0 \end{array} \right\}$$

7.17.1.4

$$X_{qm} = \left\{ \sum_{i=1}^{N_{qm}} m_i \right\}^{-1} \left\{ \sum_{i=1}^{N_{qm}} (X_i + X_{ri}) \right\}$$

m_i

LEVEL I - CALCULATE LCG OF P/M TYPE i, NUMBER j (P/M_{ij})
FRONT END OF P/M (i = 1: PALLET; i = 2: MODULE)

X_{ij}^0 = LCG OF P/M_{ij} WITH NO PL

M_{ij}^0 = MASS OF P/M_{ij} WITH NO PL

X_{ijk}^{PL} = LONGITUDINAL POSITION OF PL K ON P/M_{ij}

M_{ijk}^{PL} = MASS OF PL K ON P/M_{ij}

N_{ij} = NUMBER OF PL ON P/M_{ij}

M_{ij} = MASS OF P/M_{ij}

X_{ij} = LCG OF P/M_{ij}

LEVEL II - CALCULATE LCG OF FC TYPE q, NUMBER m (FC_{qm}),
WHERE P/M_i SUCCESSIVELY NUMBERED STARTING
FROM FRONT END OF BAY WITH i = 1

X_i = LCG P/M_i (ACTUALLY X_{ij} - HAVE RELABELED)

M_i = MASS P/M_i (M_{ij})

X_{qm} = DISTANCE TO FRONT OF P/M_i (P/M_{ij} RELABELED) FOR FC_{qm}

N_{qm} = NUMBER P/M ON FC_{qm}

ORIGINAL PAGE
OF POOR QUALITY

RODQUE FRAME

FIGURE 7.17.1

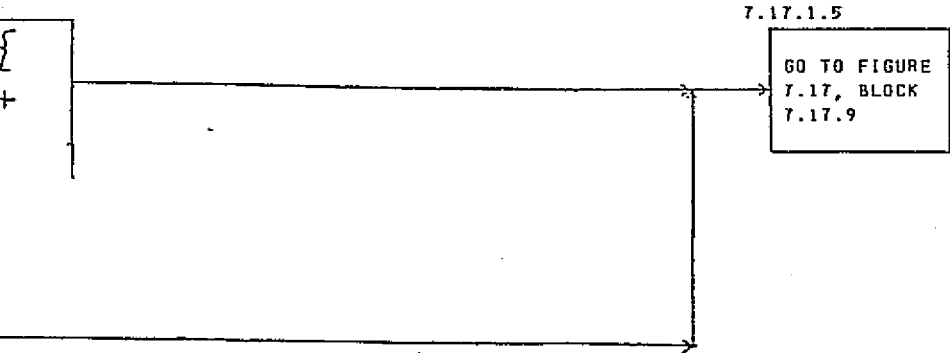

FIELDWORK 2

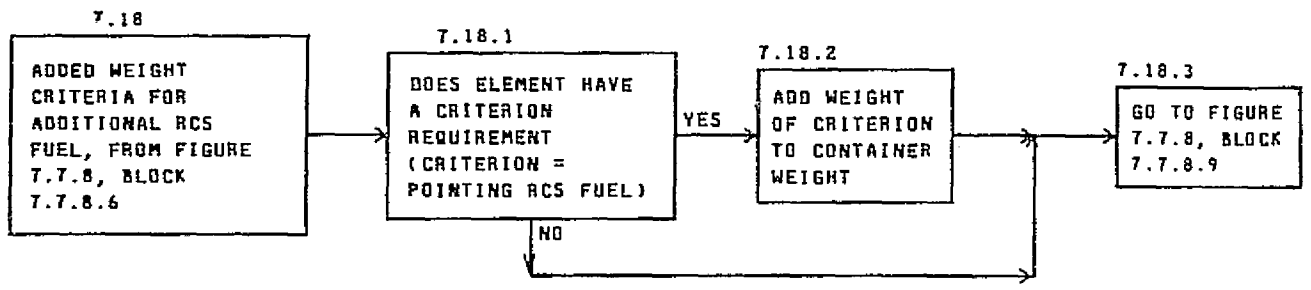

REVISIONS /

MCDONNELL DOUGLAS

7.18.3

GO TO FIGURE
7.7.8, BLOCK
7.7.8.9

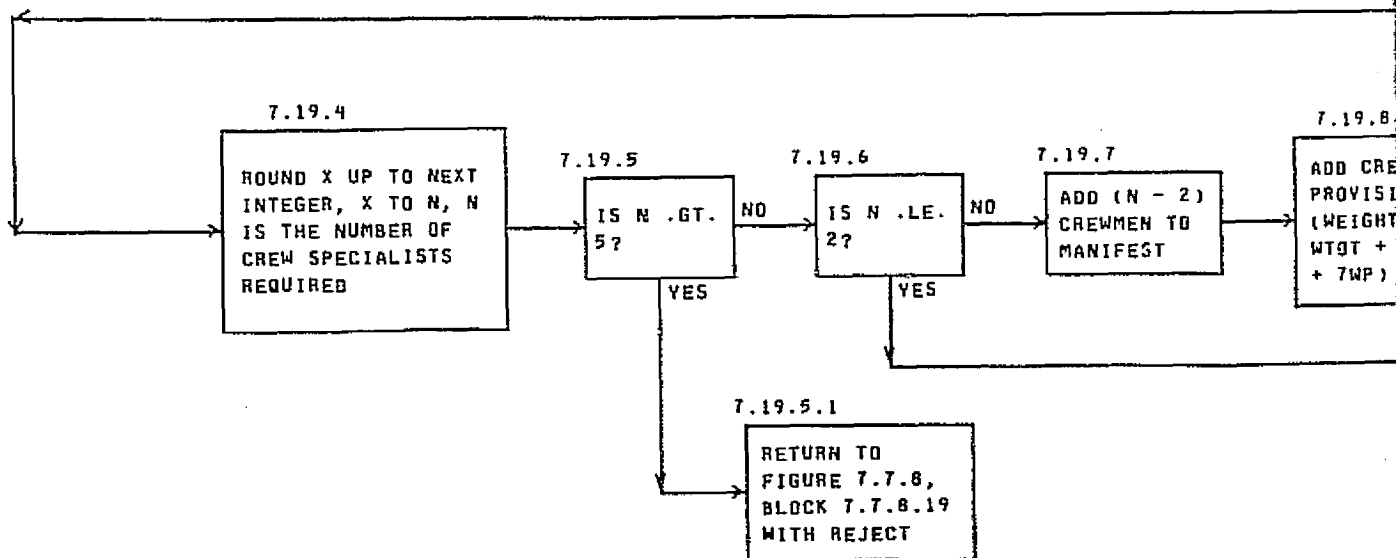
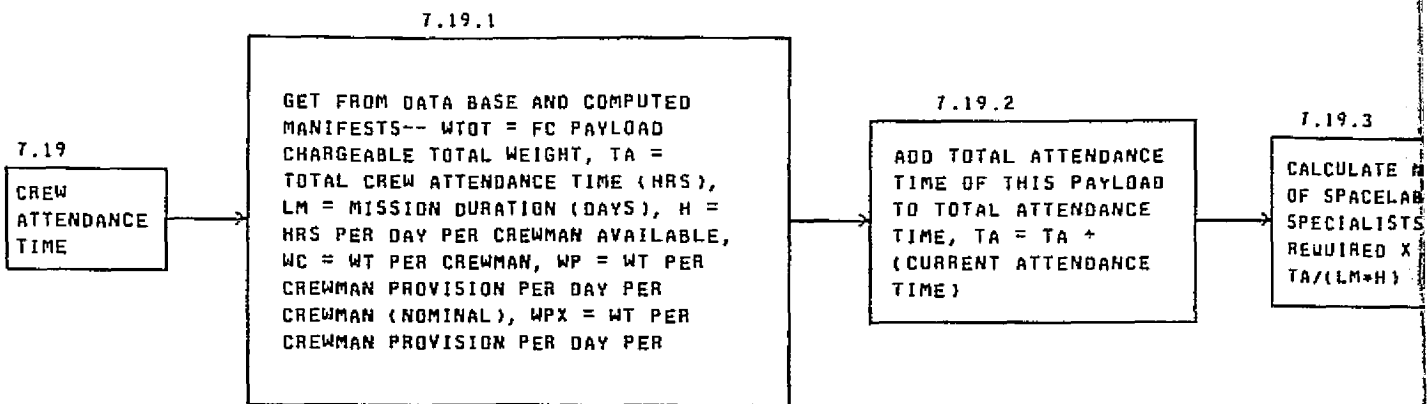

FOLDOUT FRAME

ORIGINAL PAGE IS
OF POOR QUALITY

FIGURE 7.19

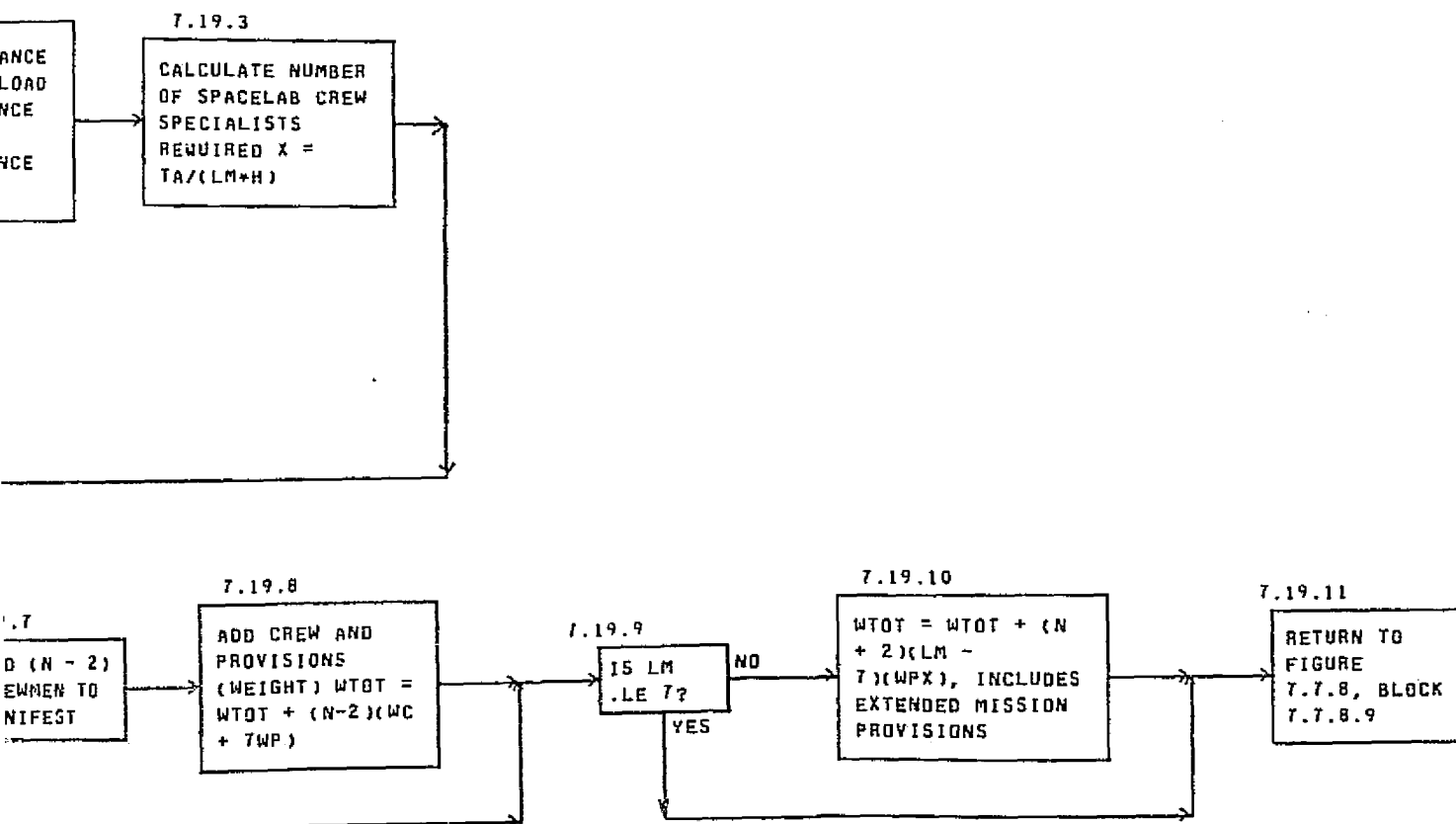

FOLDOUT FRAME

FIGURE 7.20

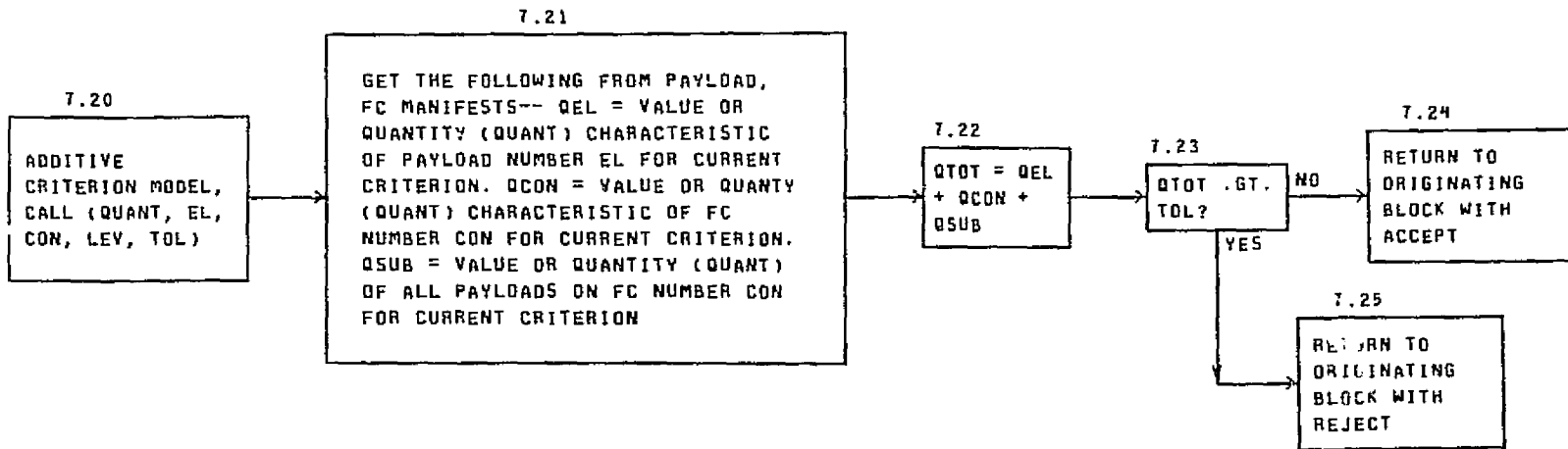

ORIGINAL PAGE IS
OF POOR QUALITY

FIGURE 7.21

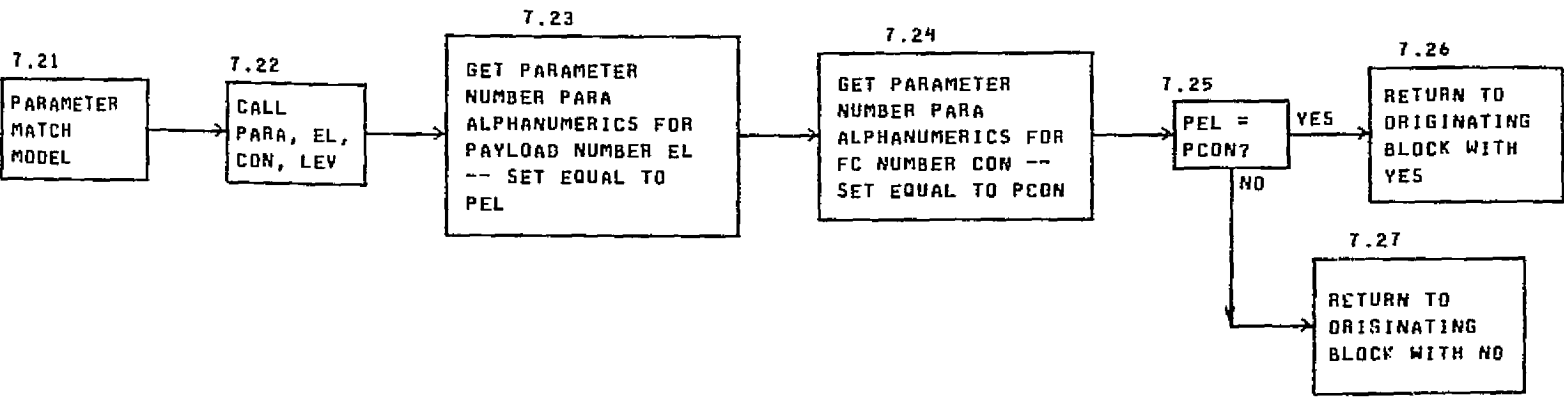

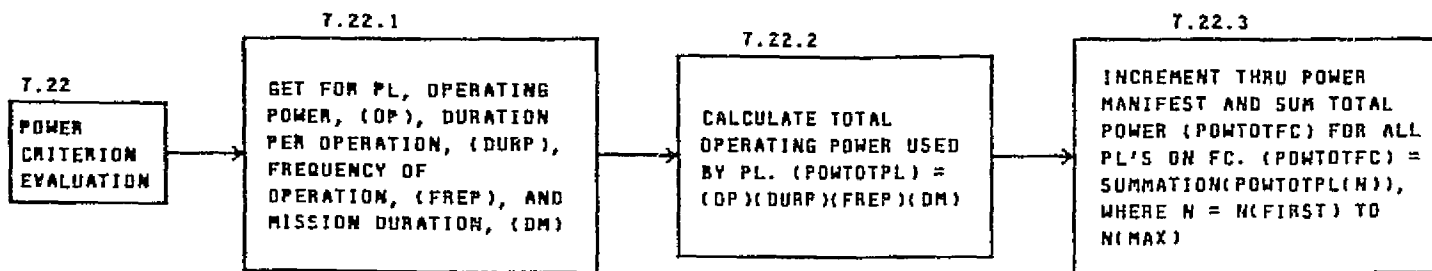

ORIGINAL PAGE IS
OF POOR QUALITY

FOLDOUT FRAME /

FIGURE 7.22

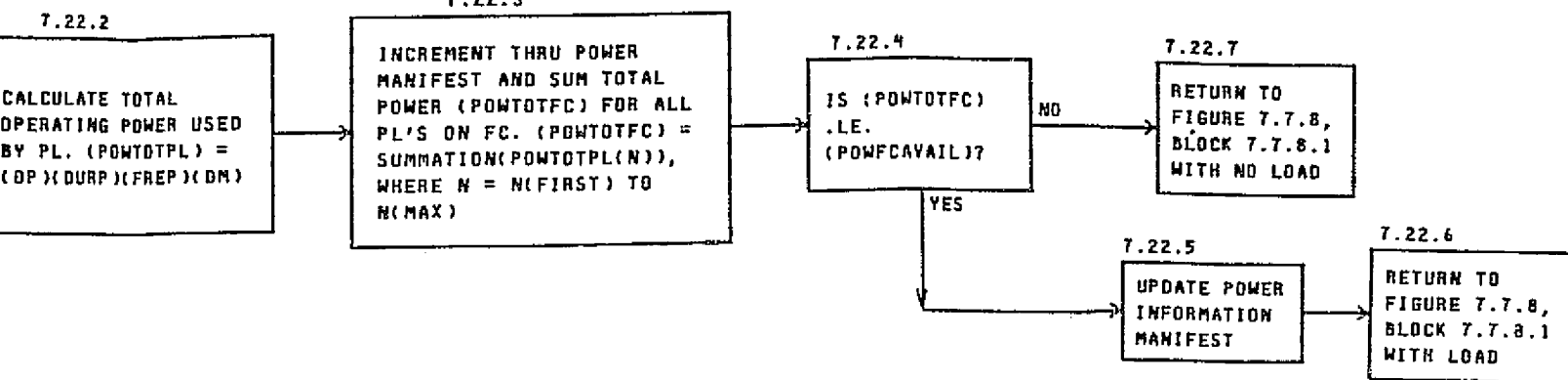

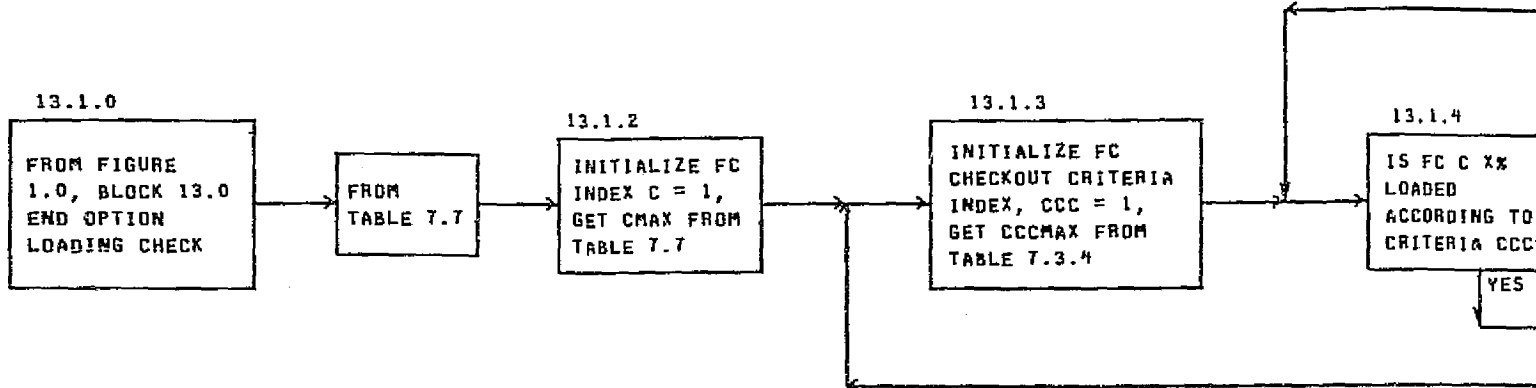

FOLDOUT FRAME |

FIGURE 13.1

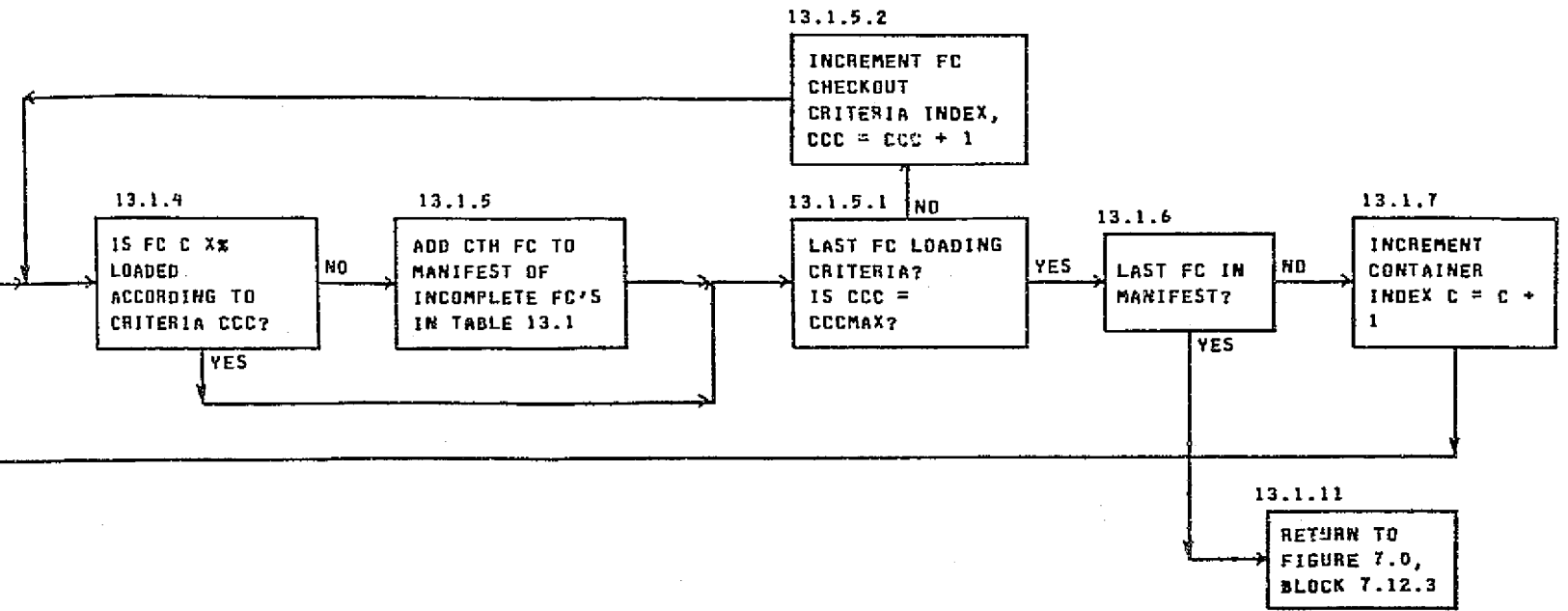

BOLDOUT FRAME 2

13.2.0

FROM FIGURE 7.0,
BLOCK 7.12.14--
INTERACTIVE
REPACKING OPTION

13.2.1

GET FC
MANIFEST

13.2.2

DUPLICATE
MANIFEST
INTEMPORARY FILE
AND DISPLAY

13.2.3

OLD FC ID ≠ ?
PAYLOAD ID
= ? NEW FC
ID = ?

13.2.5

SUBTRACT
PAYLOAD
FROM OLD FC

13.2.6

RECALCULATE
OLD FC
RESOURCE
USAGE

AND

13.2.7

TEMPORARY
STORAGE OF OLD
FC NEW
RESOURCE USAGE

AND

13.2.8
DISPLAY NEW
FC RESOURCE
USAGE
MANIFEST

13.2.9

ADD PAYLOAD
FROM OLD FC
TO NEW FC

13.2.10

RECALCUL
NEW FC
RESOURCE
USAGE

FOLDOUT FRAME 1

FIGURE 13.2

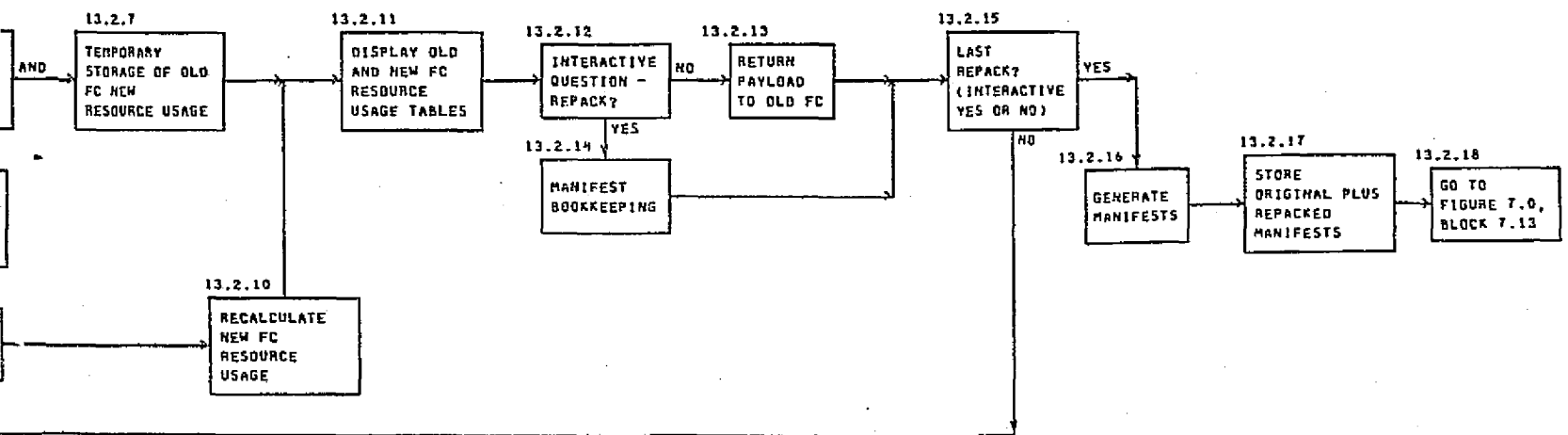

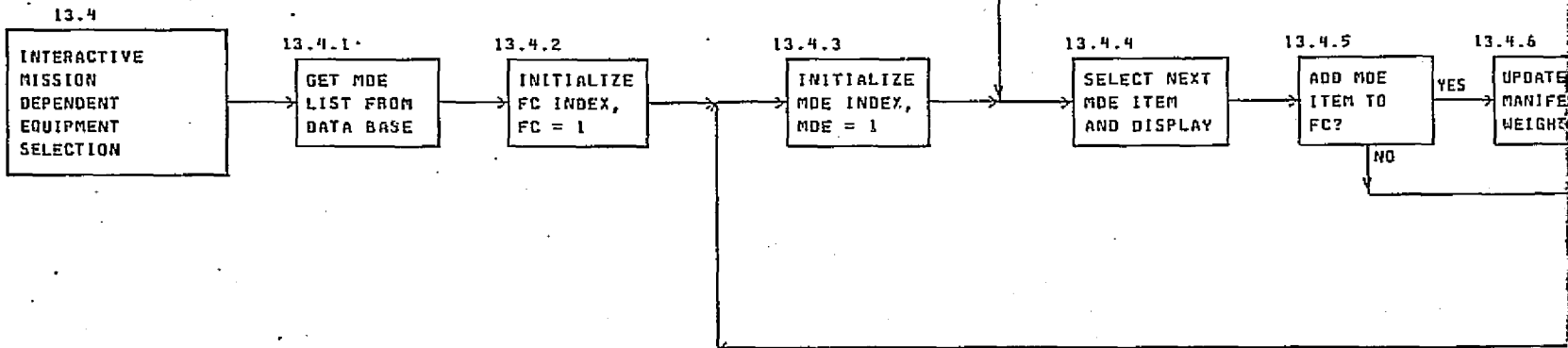

C.2

FOLDOUT FRAME

ORIGINAL PAGE IS OF POOR QUALITY

FIGURE 13.4

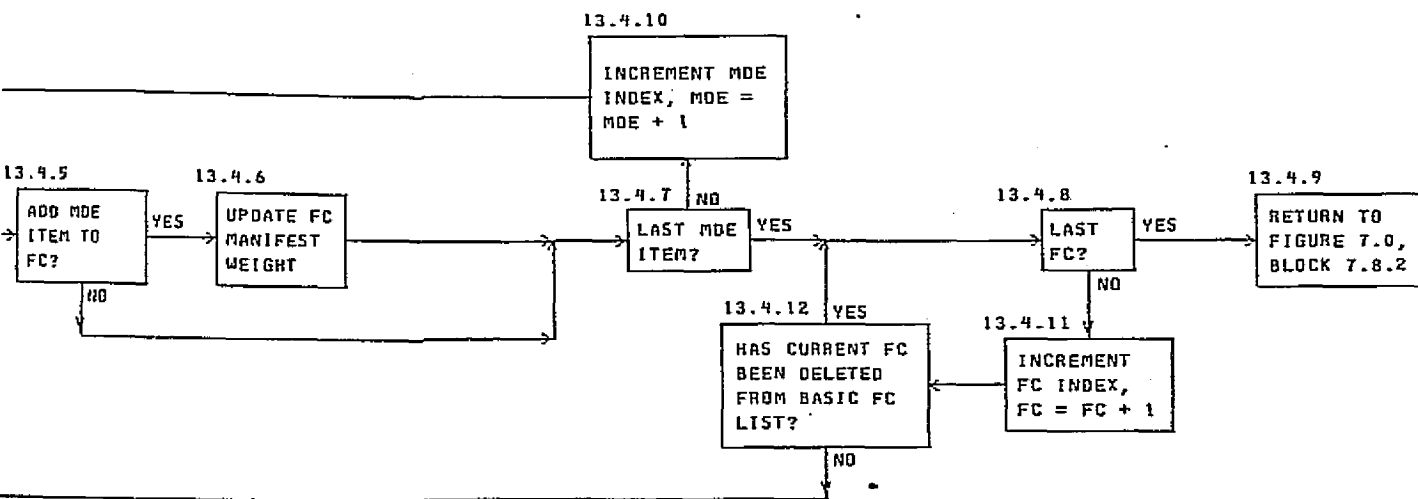

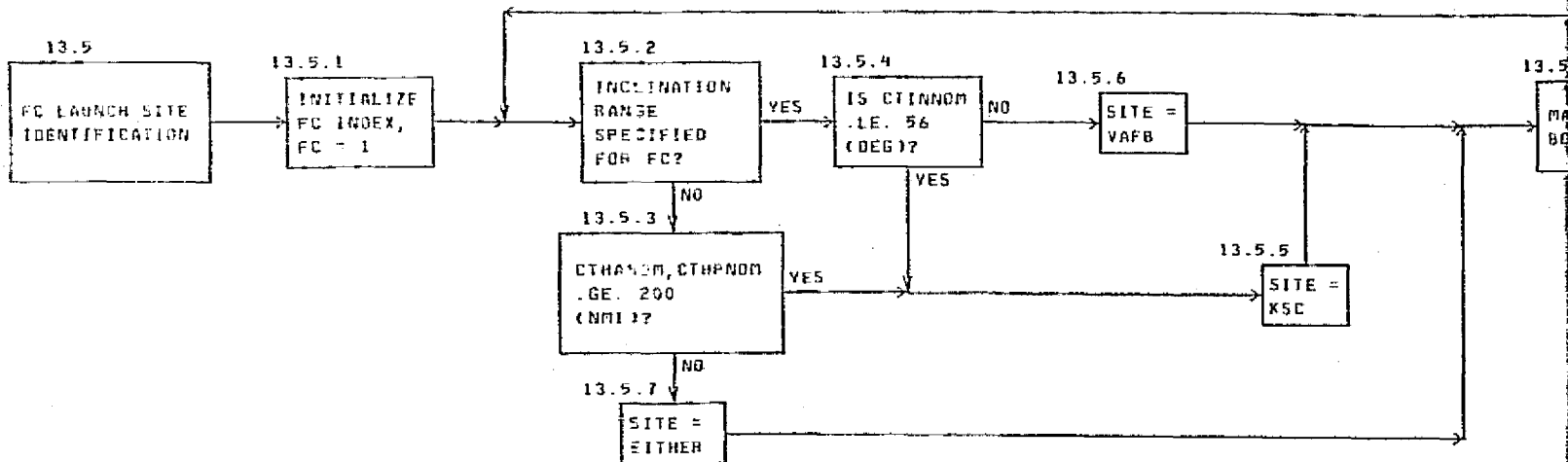

ENCLOSURE ATTACHED /

ORIGINAL PAGE IS OF POOR QUALITY

FIGURE 13.5

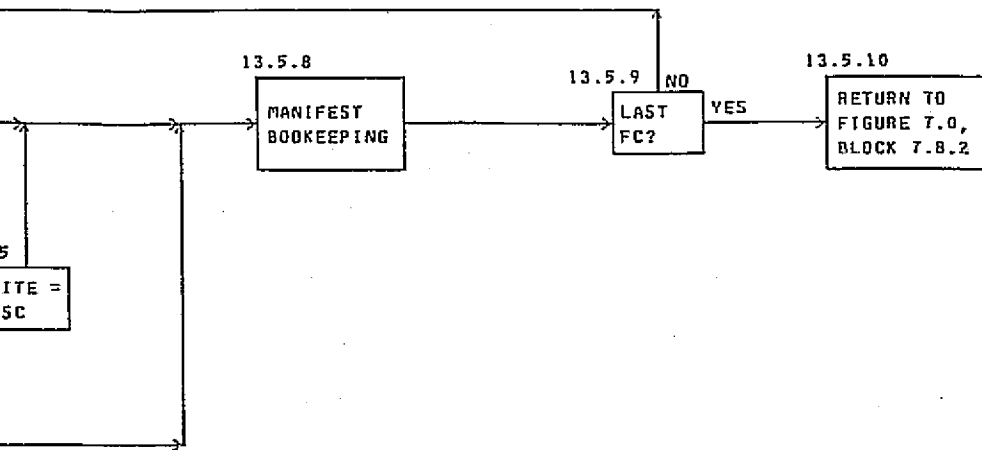

BOLESCUE TRAINING

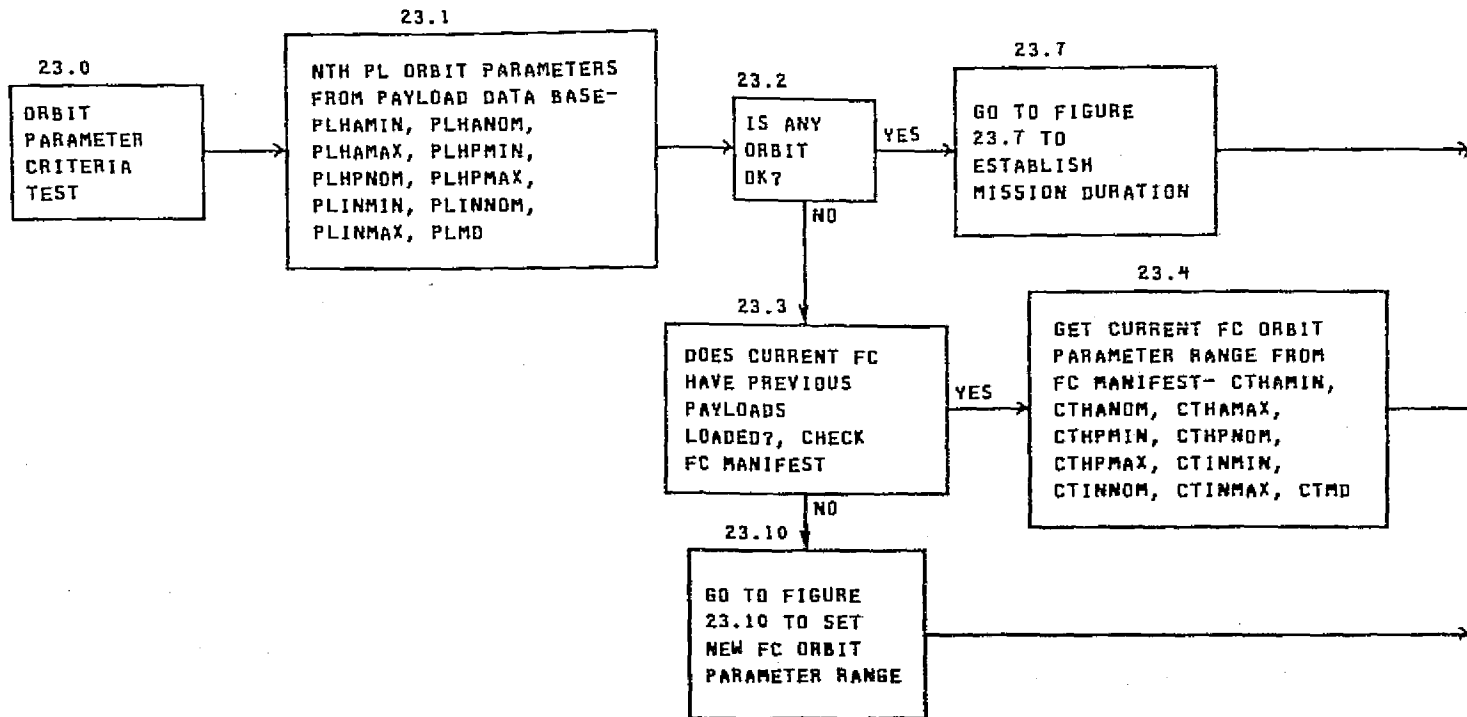
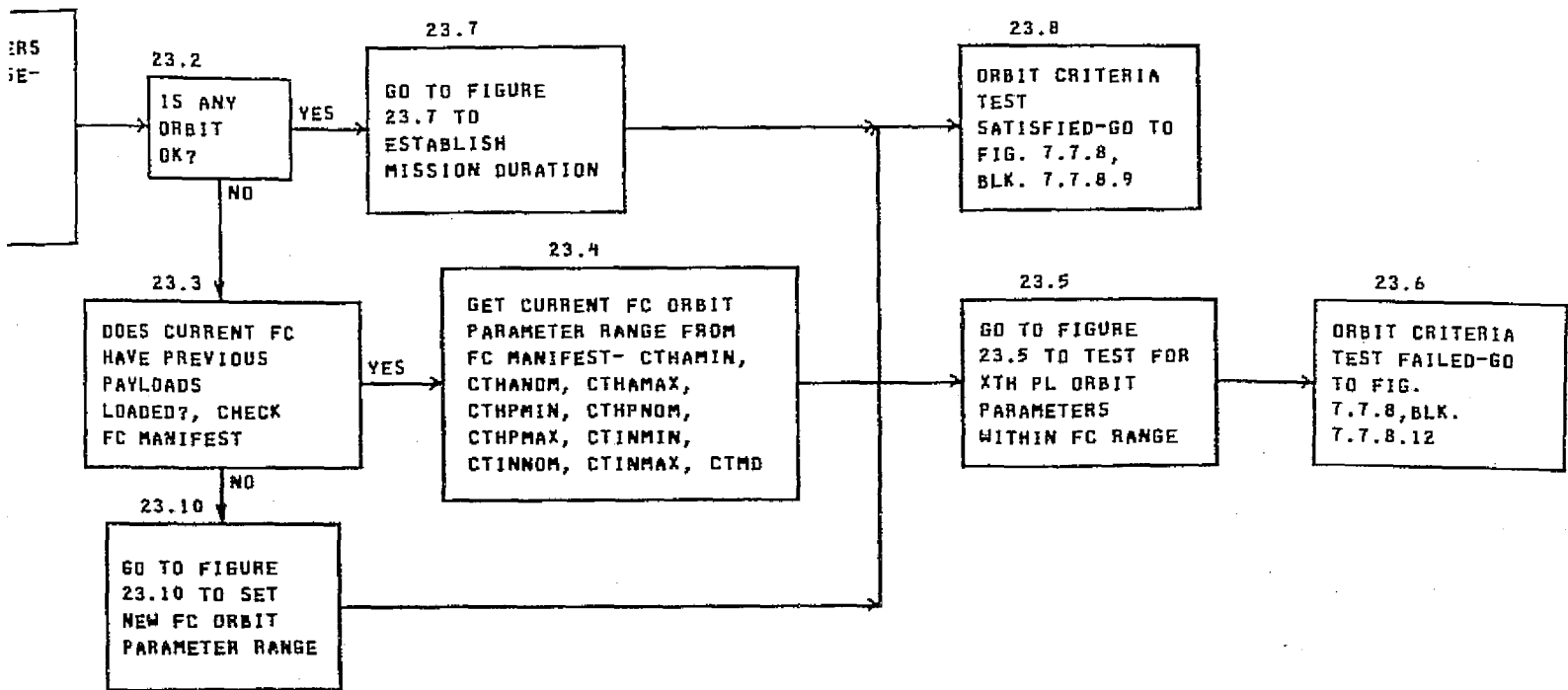
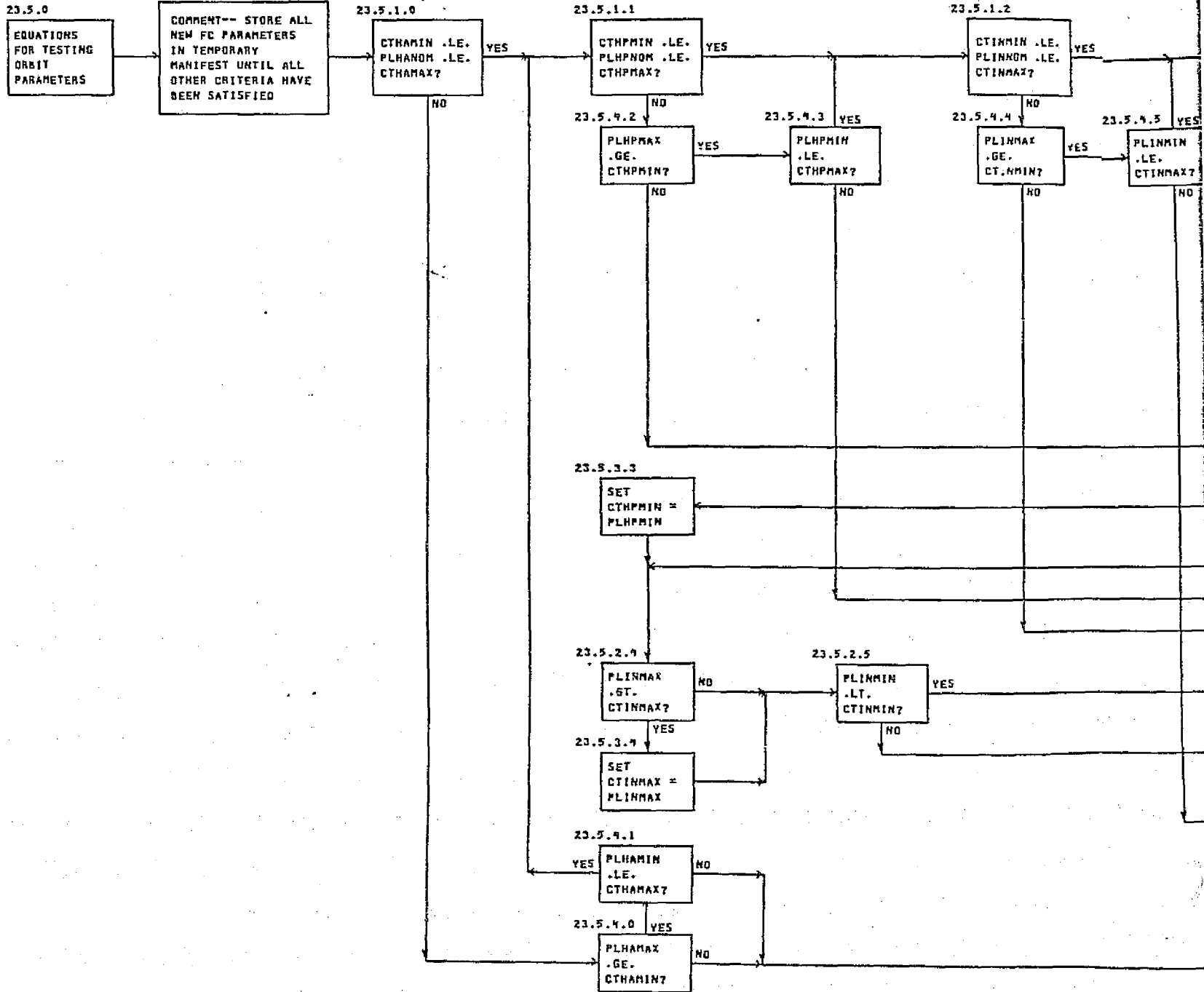

FIGURE 23.0



FOLDOUT DRAWING 2



ORIGINAL PAGE IS
OF POOR QUALITY

FIGURE 23.5

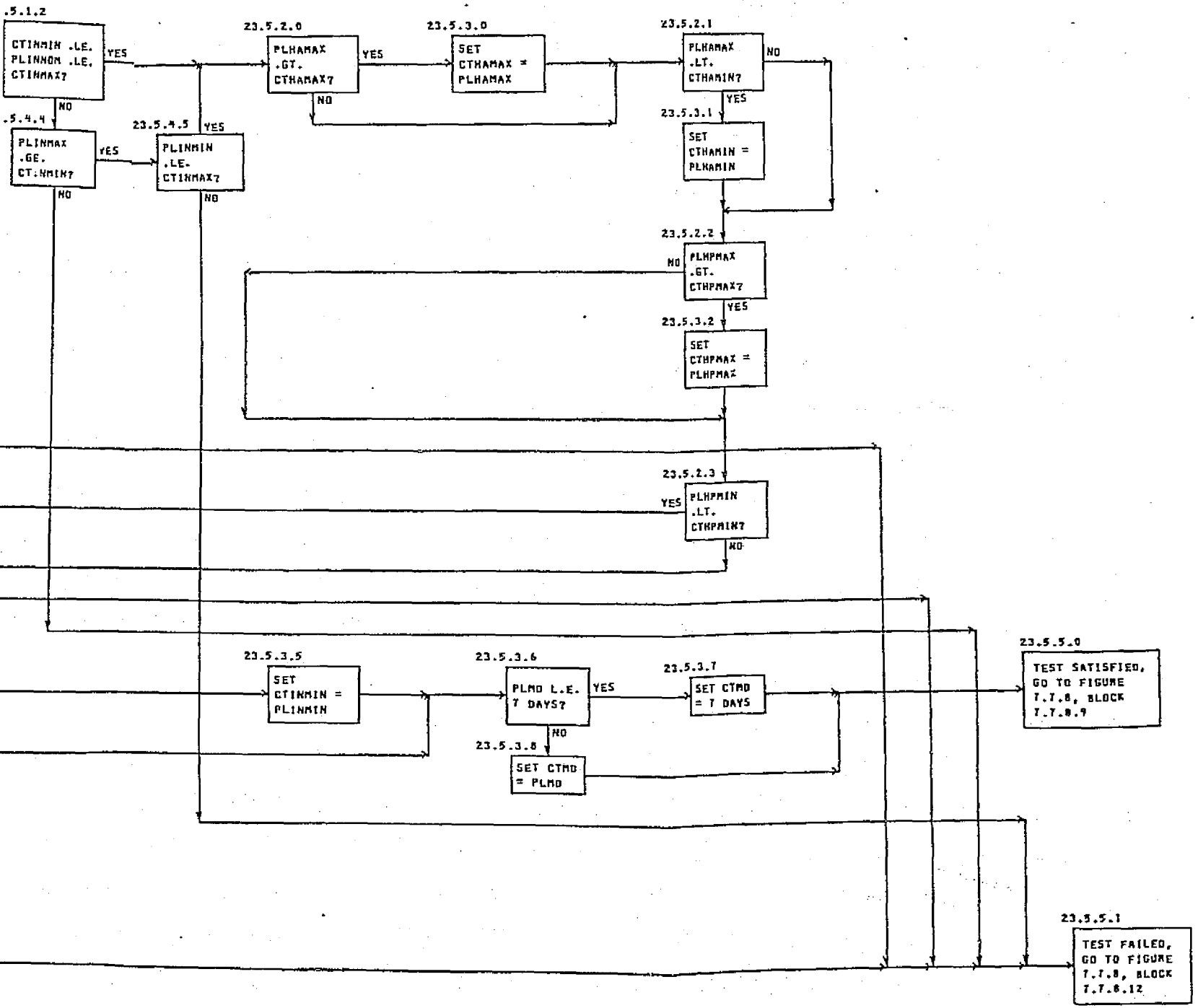
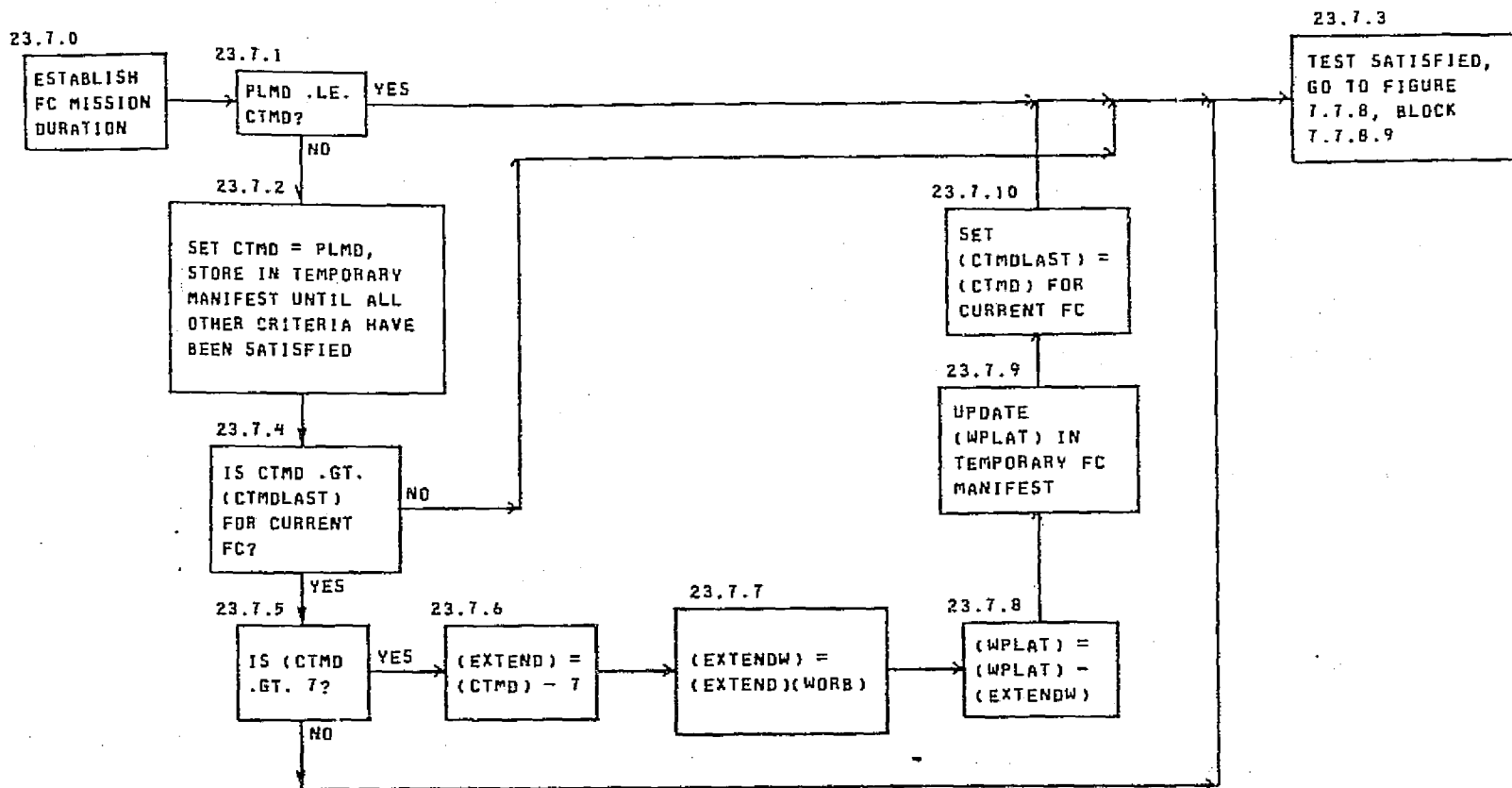

FIGURE 23.7



ORIGINAL PAGE IS OF POOR QUALITY

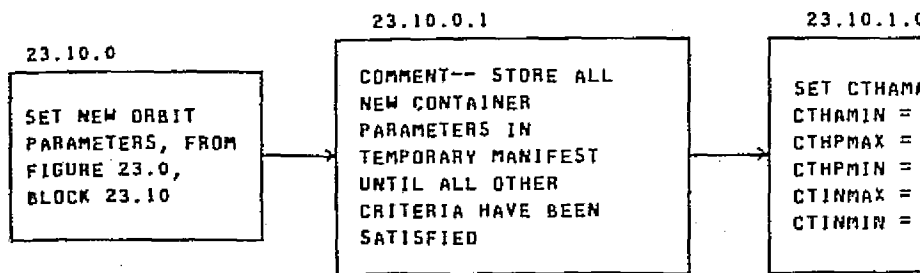

Table 23.5

DEFINITION OF SYMBOLS FOR FIGURES 23.5, 23.7, AND 23.10

HA = Apogee altitude
 HP = Perigee altitude
 IN = Inclination
 PL = Payload
 CT = Container (pallet or module rack)
 MIN = Minimum
 MAX = Maximum
 NOM = Nominal
 MD = Mission duration

Example: CTHAMIN = Container apogee altitude minimum
 PLMD = Payload mission duration

.LT. = Less than
 .LE. = Less than or equal
 .GT. = Greater than
 .GE. = Greater than or equal

ORIGINAL PAGE IS
 OF POOR QUALITY

REPRODUCTION

FIGURE 23.10

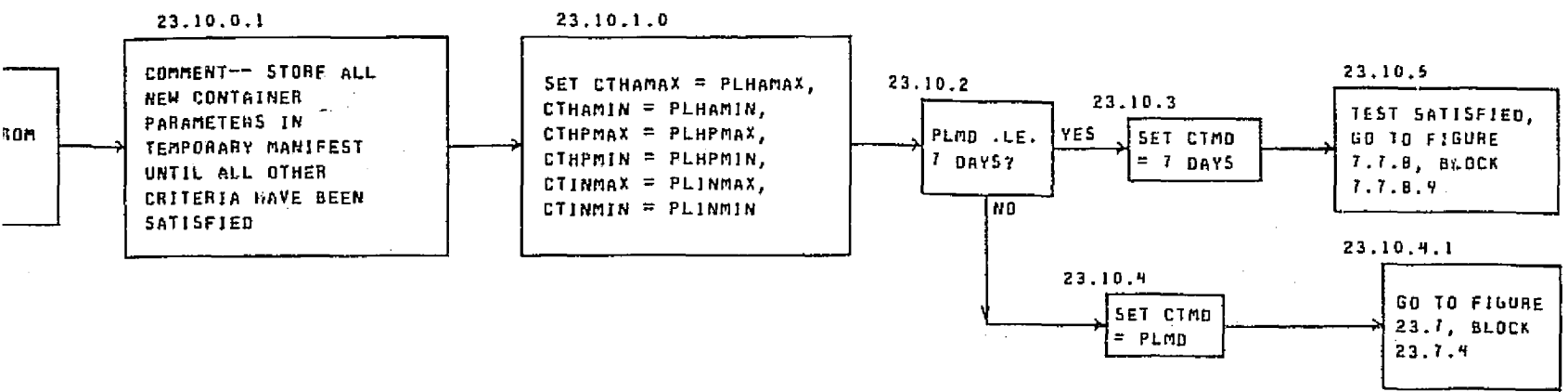

ES 23.5, 23.7, AND 23.10

rack)

ogee altitude minimum
sion duration

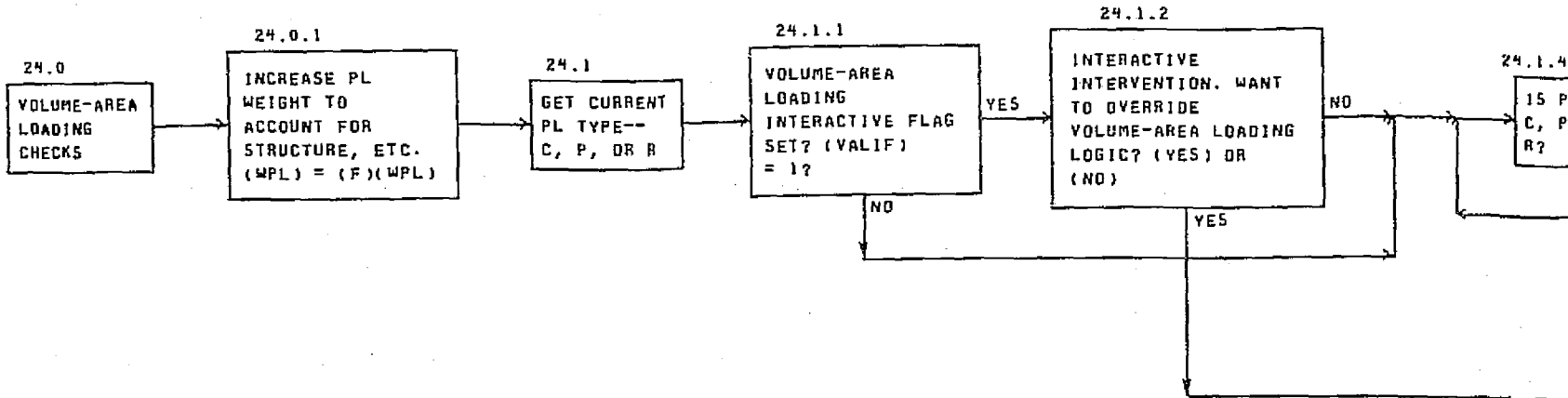

FIGURE 24.0

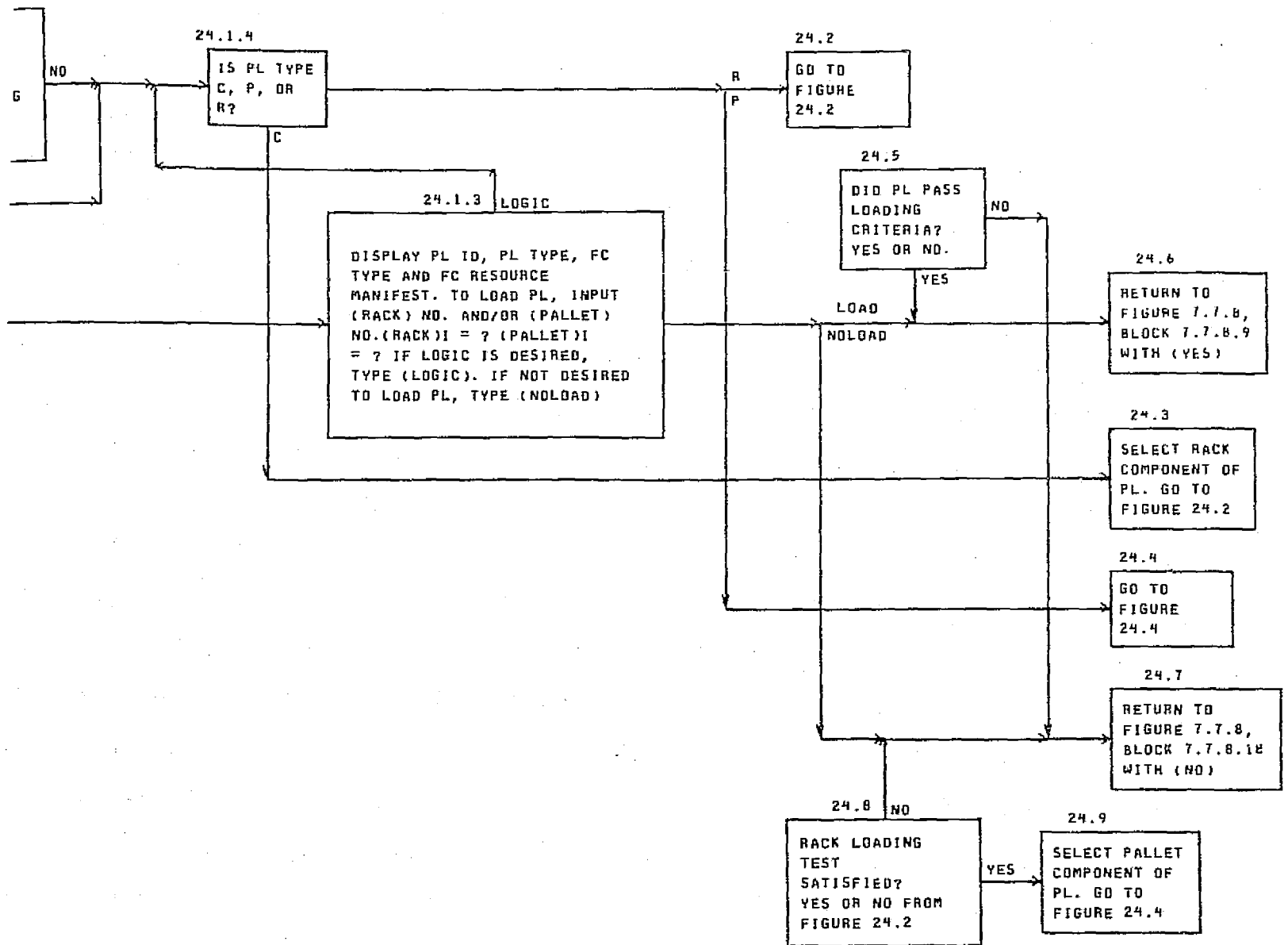
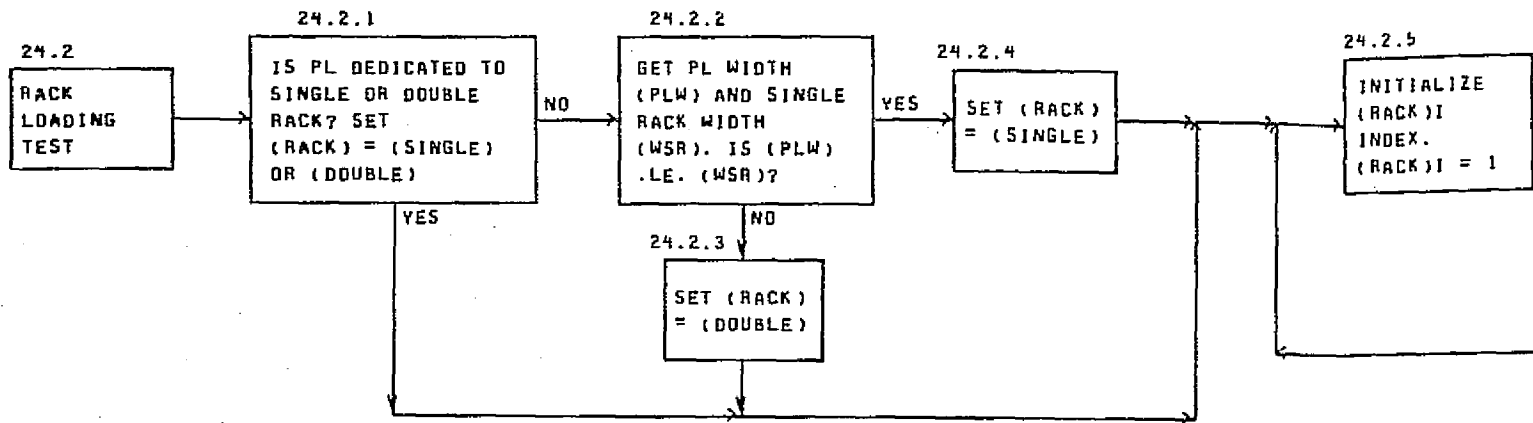

EXHIBIT 2



FOLDOUT FRAME /

MCDONNELL DOUGLAS

ORIGINAL PAGE IS
OF POOR QUALITY

FIGURE 24.2

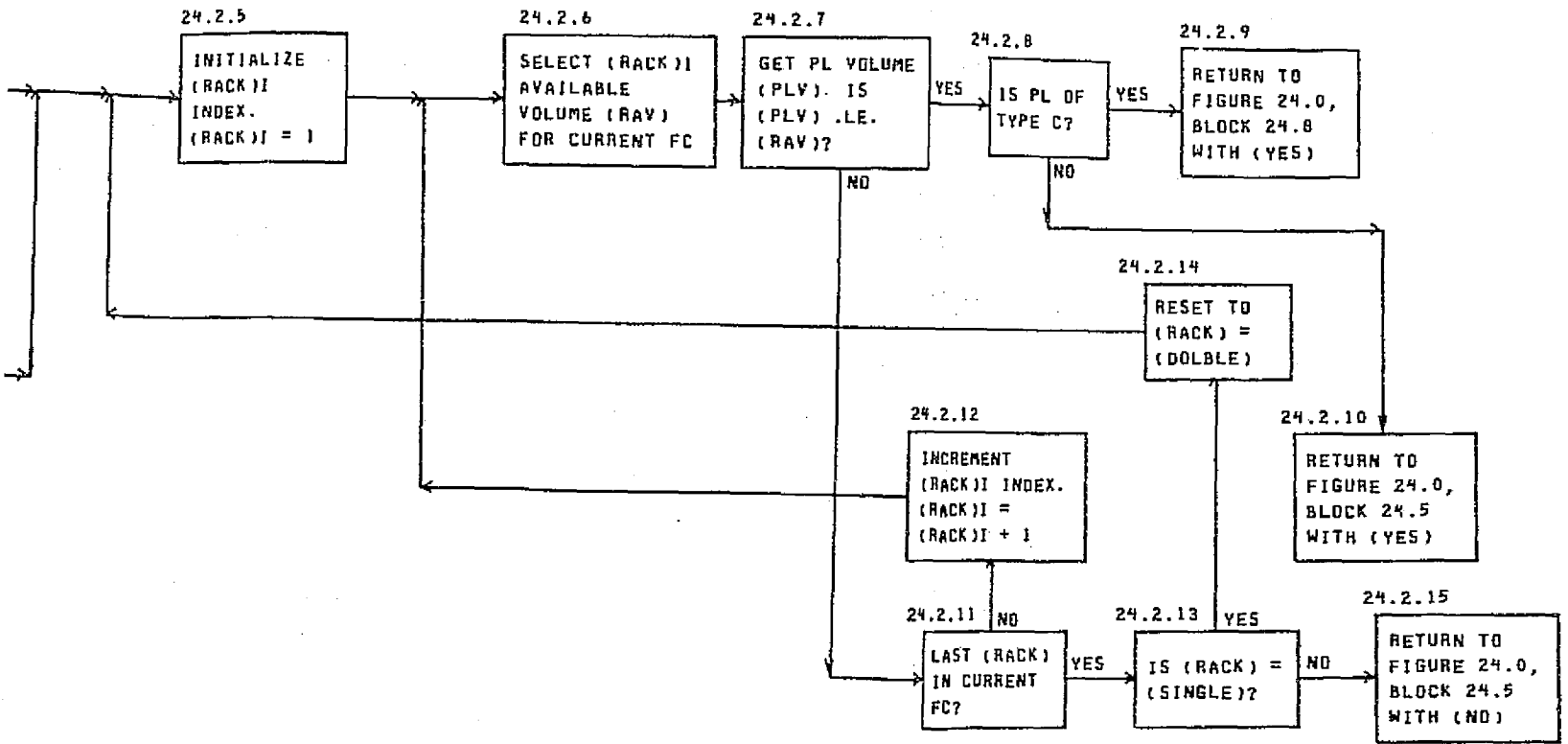
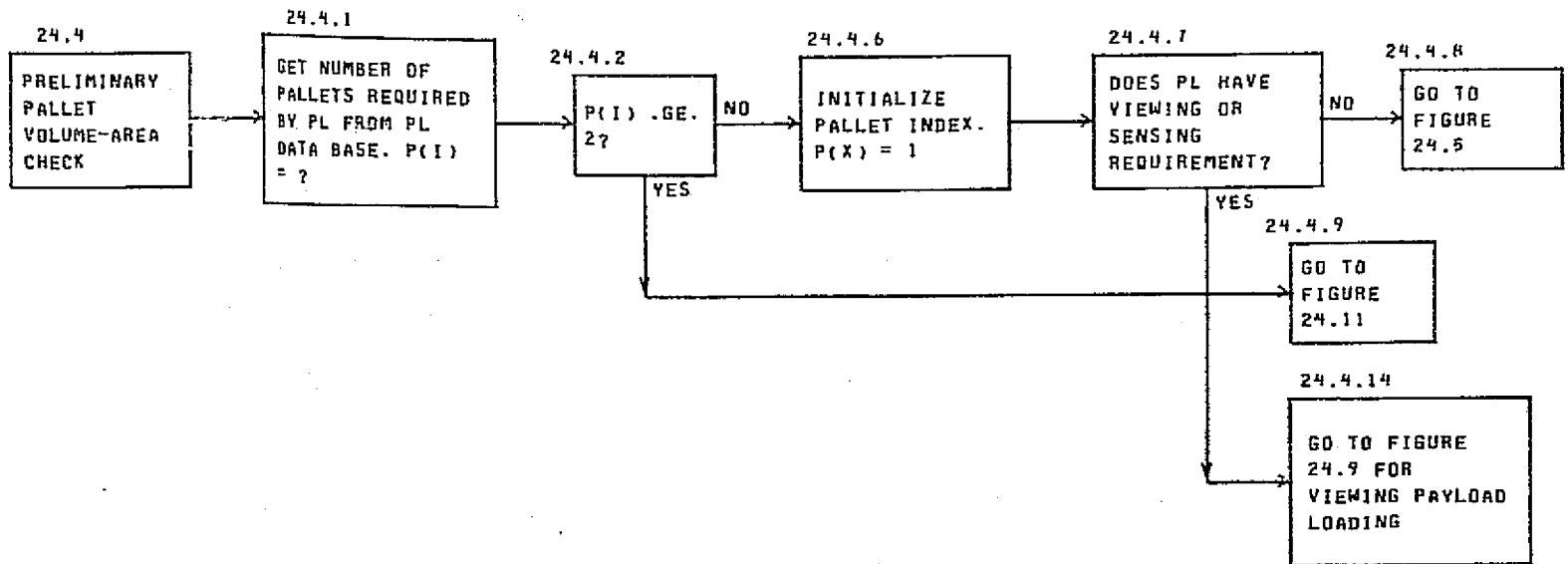
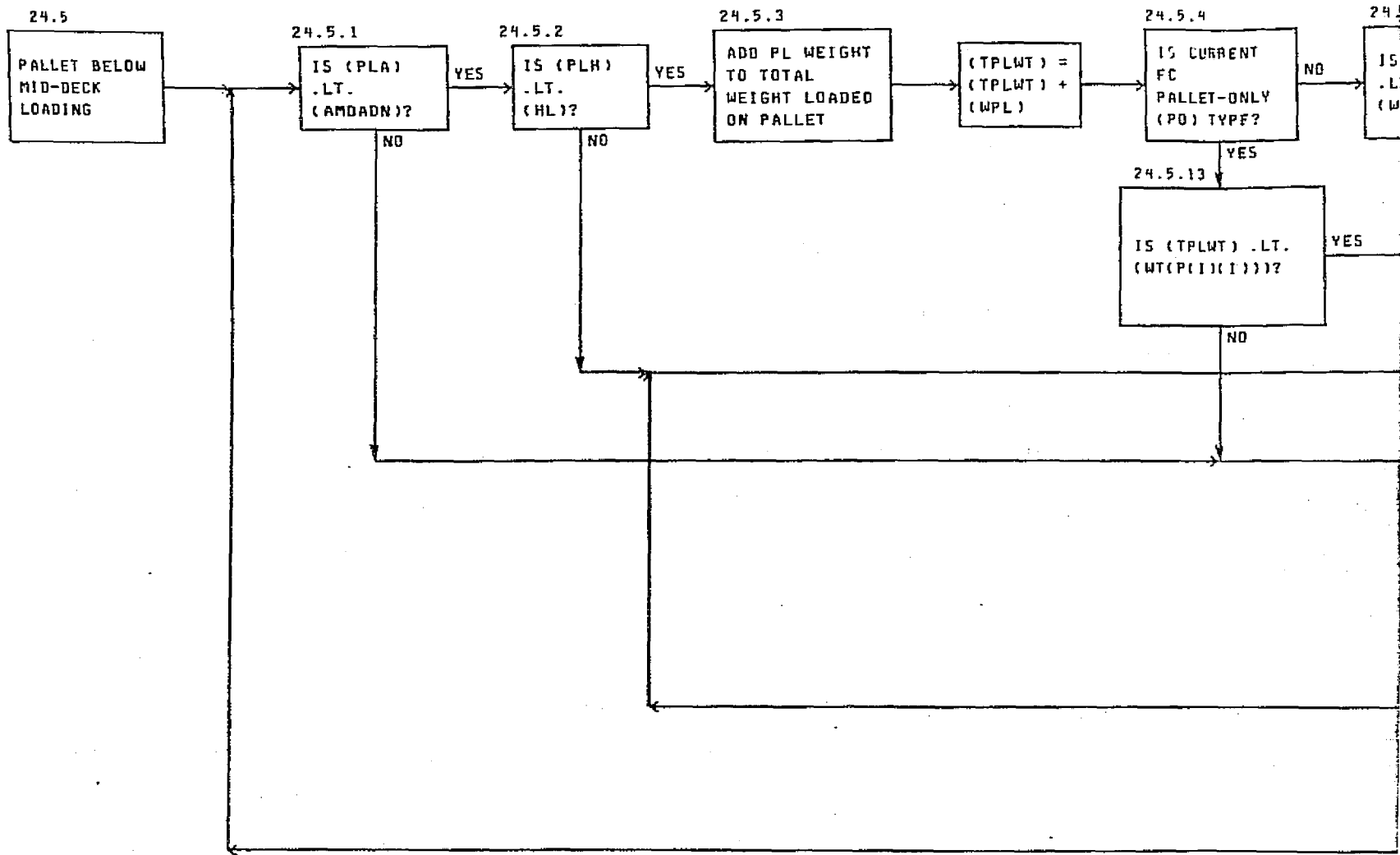

FIGURE 24.4



ORIGINAL PAGE IS
OF POOR QUALITY



OUT FRAME /

ORIGINAL PAGE IF
OF POOR QUALITY

FIGURE 24.5

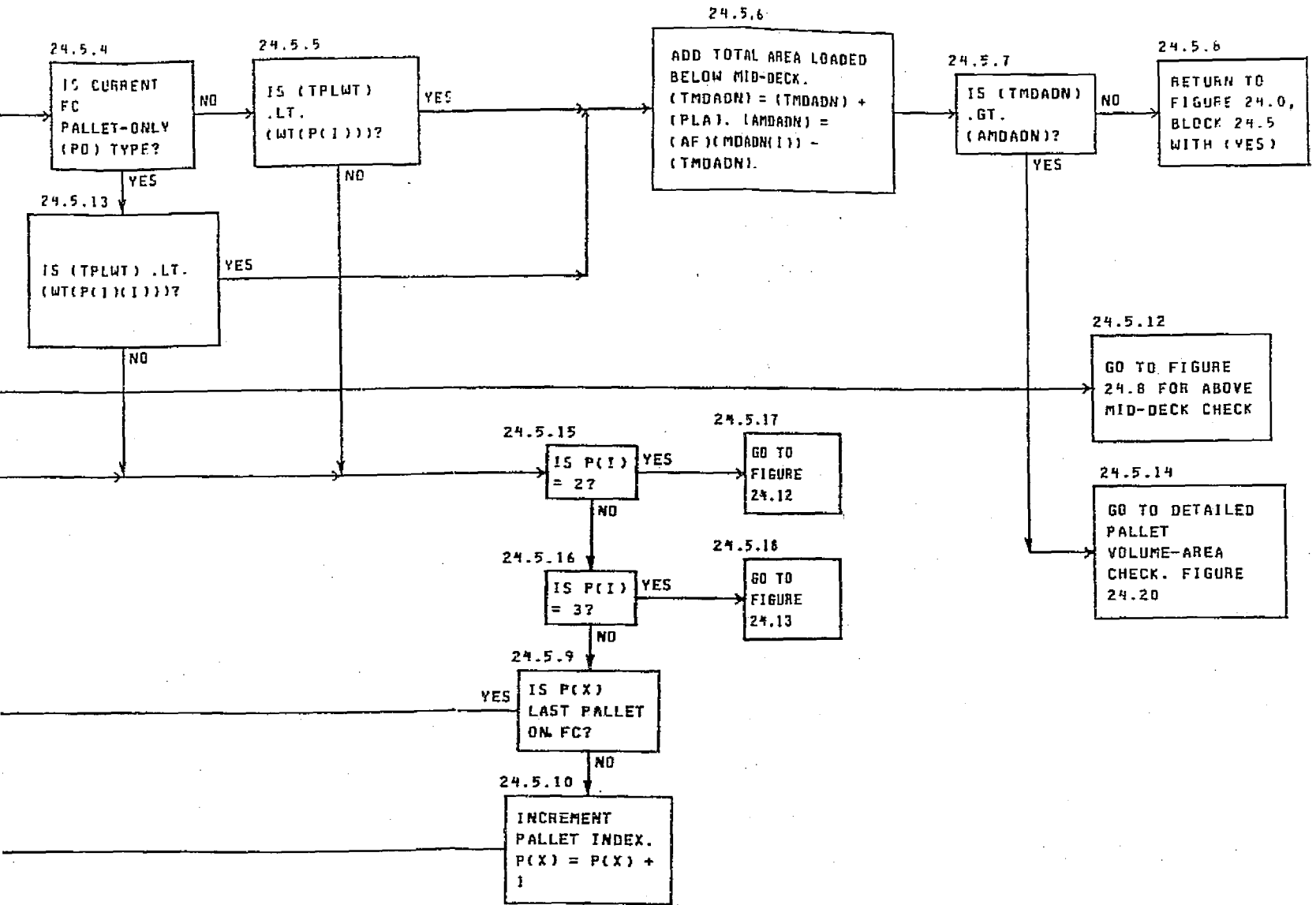

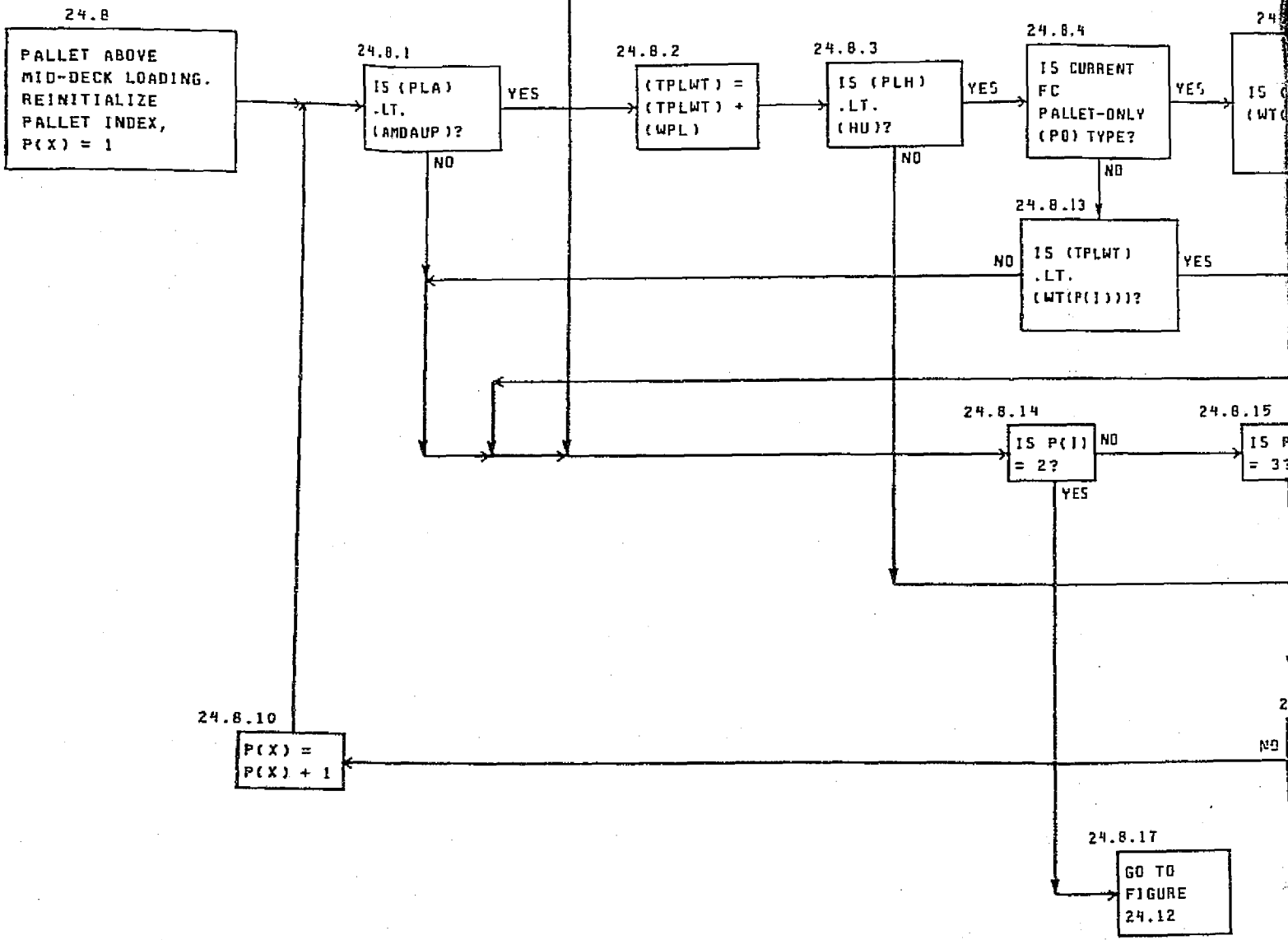

FOLDOUT FRAME

FIGURE 24.8

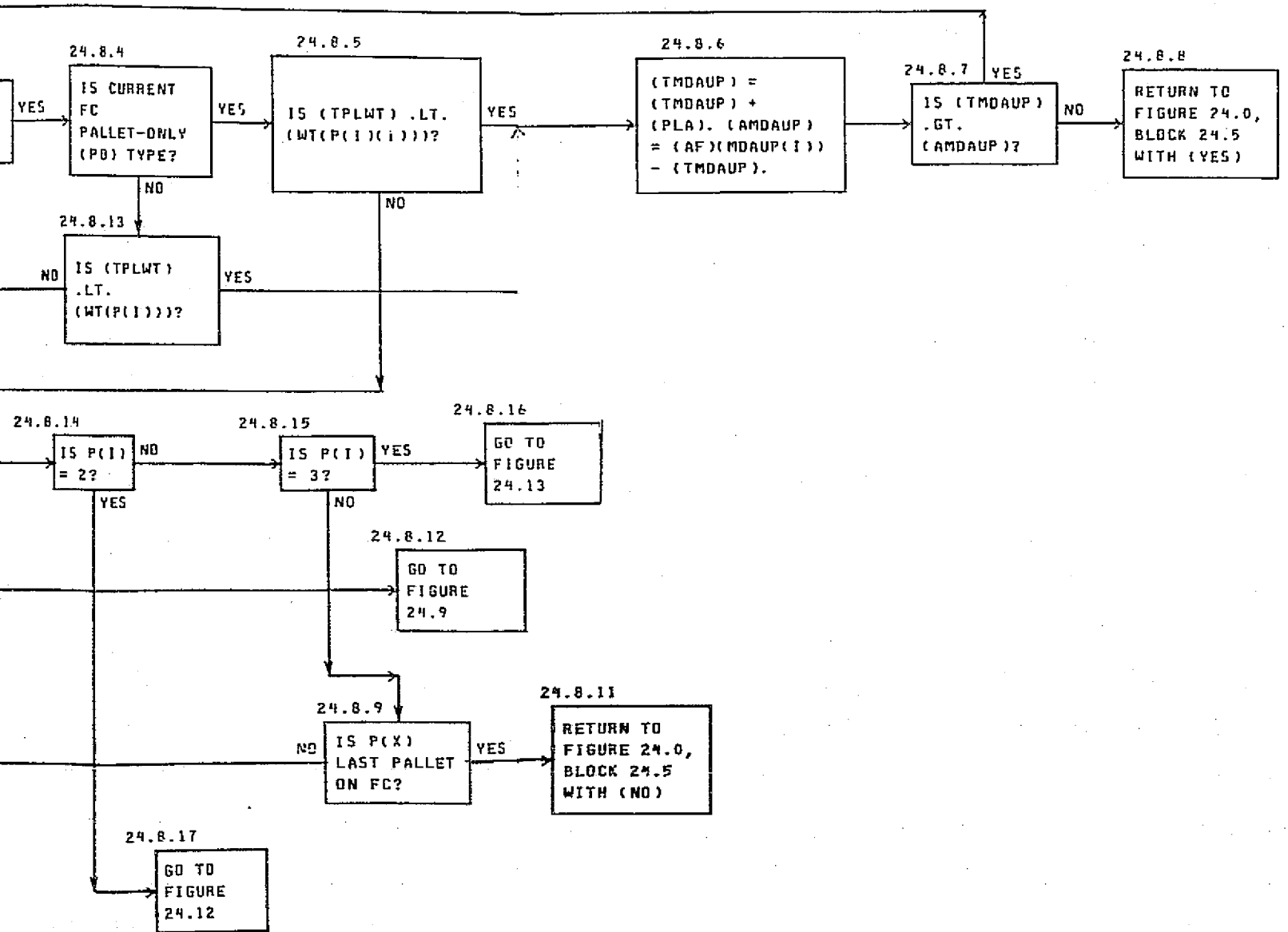

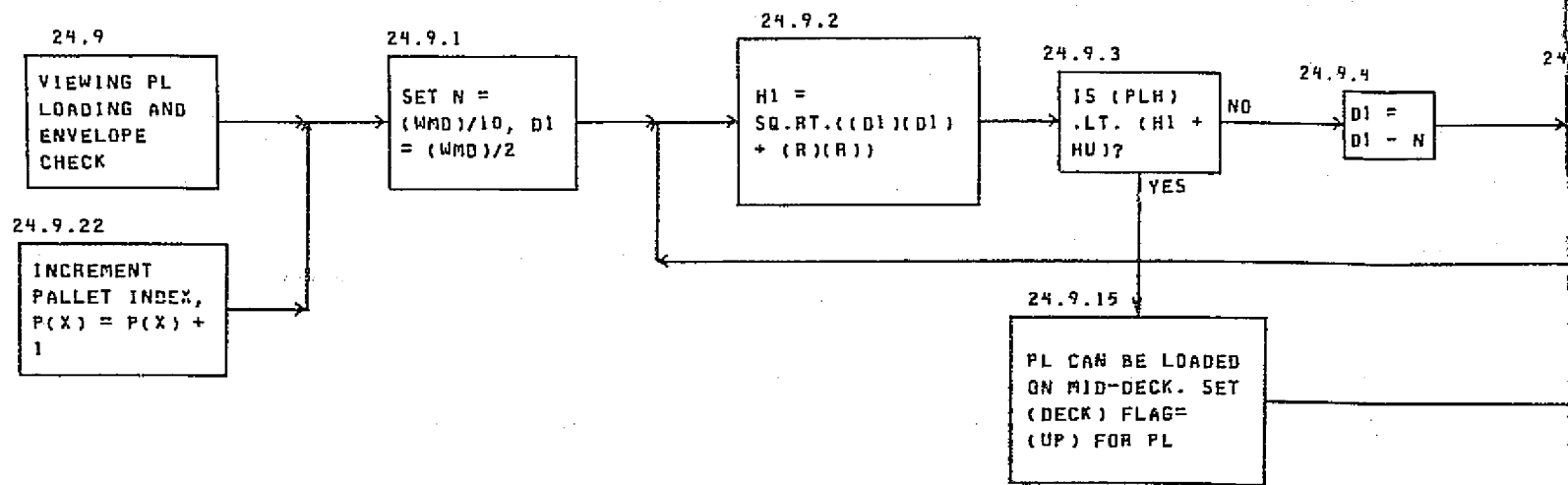

H = SQ. RT. ((D1)(D1) + (R)(R))

ORIGINAL PAGE IS OF POOR QUALITY

FOLDOUT FRAME!

FIGURE 24.9

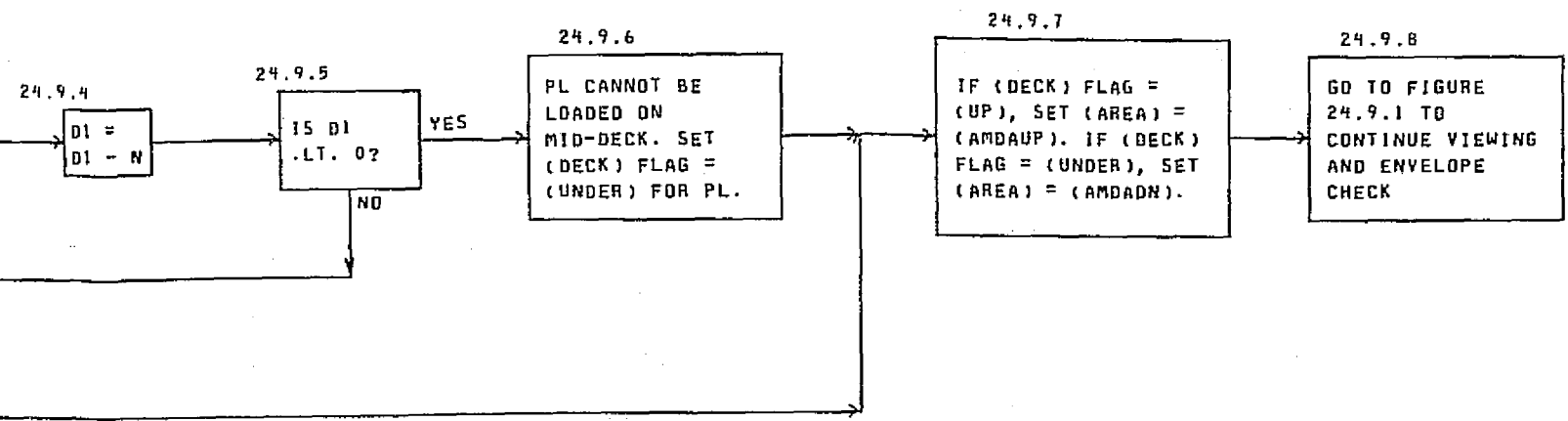

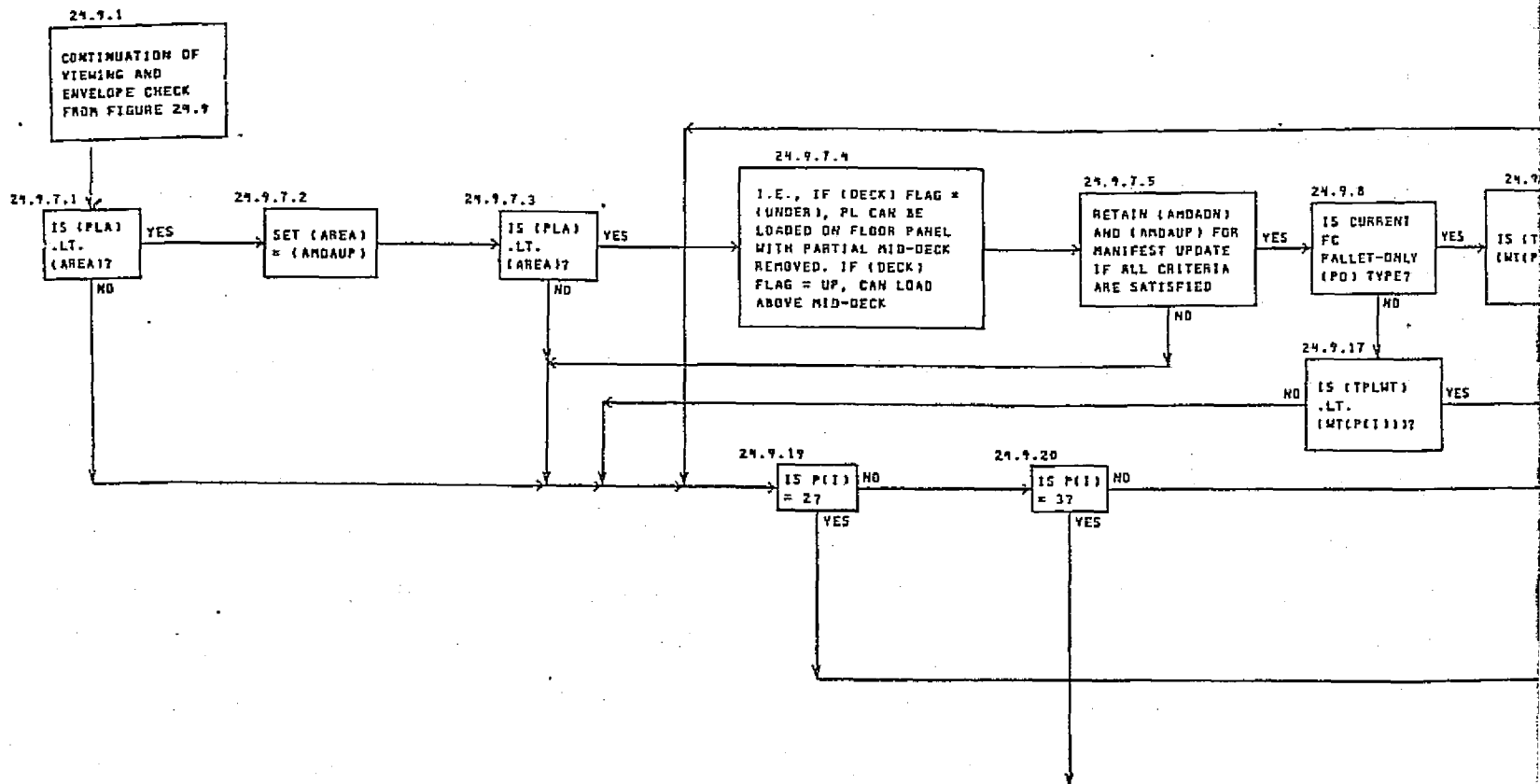

FOLDOUT FRAME /

ORIGINAL PAGE IS OF POOR QUALITY

FIGURE 24.9.1

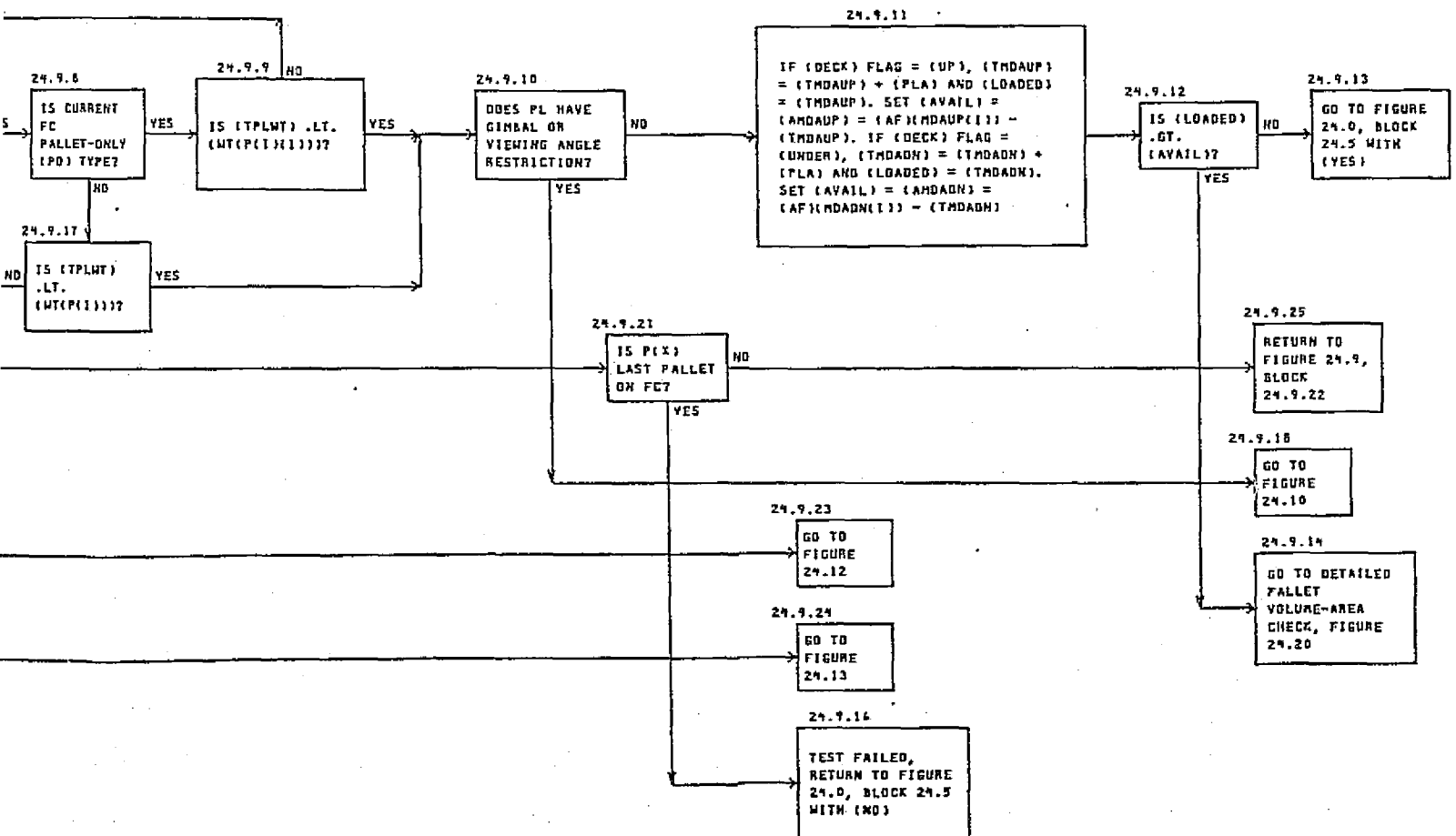

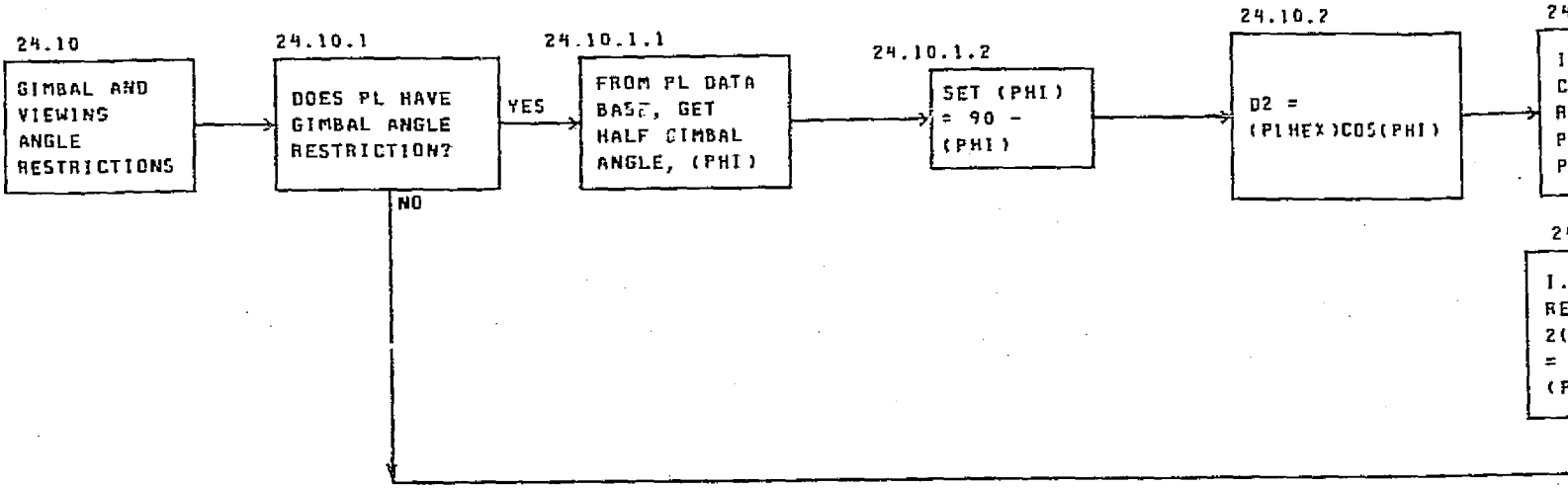

ORIGINAL PAGE IS
OF POOR QUALITY

ALDOUT FRAME

FIGURE 24.10

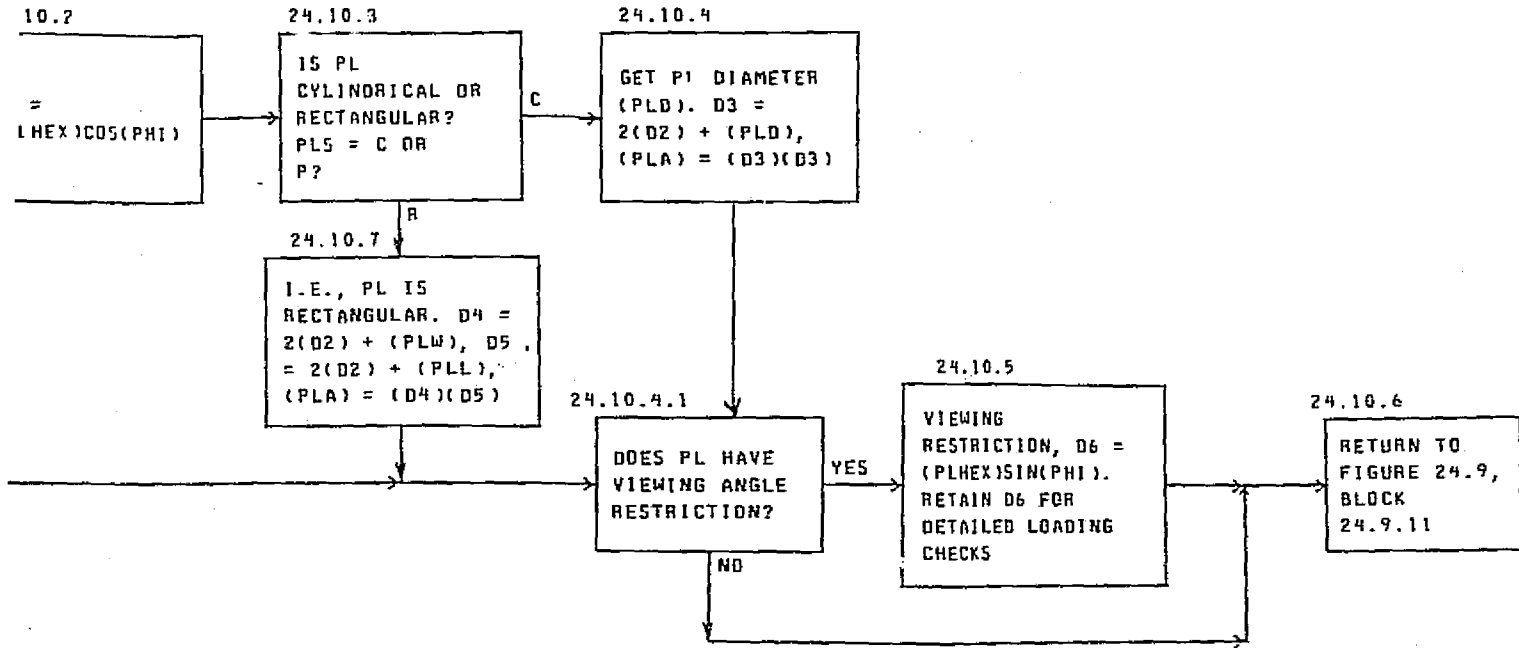

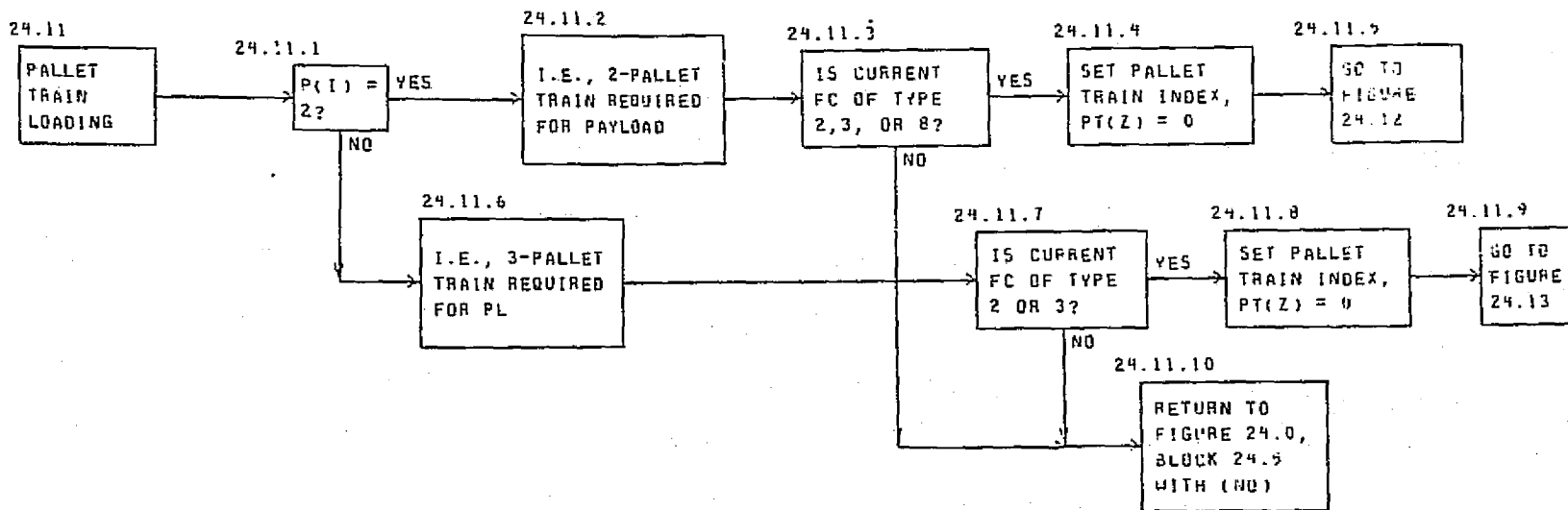

ORIGINAL PAGE IS
OF POOR QUALITY

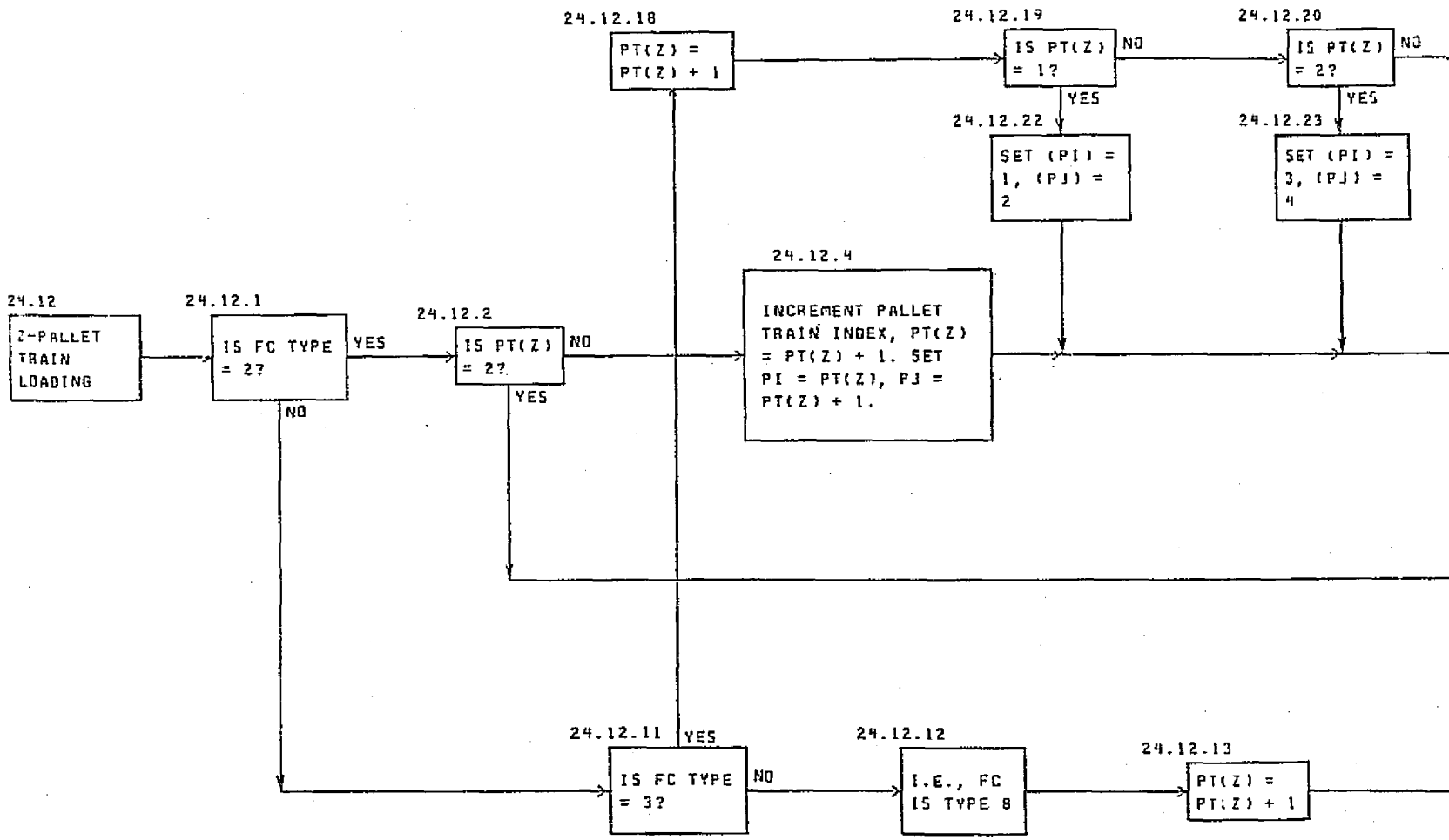

REWORK DRAWING

ORIGINAL PAGE IS OF POOR QUALITY

FIGURE 24.12

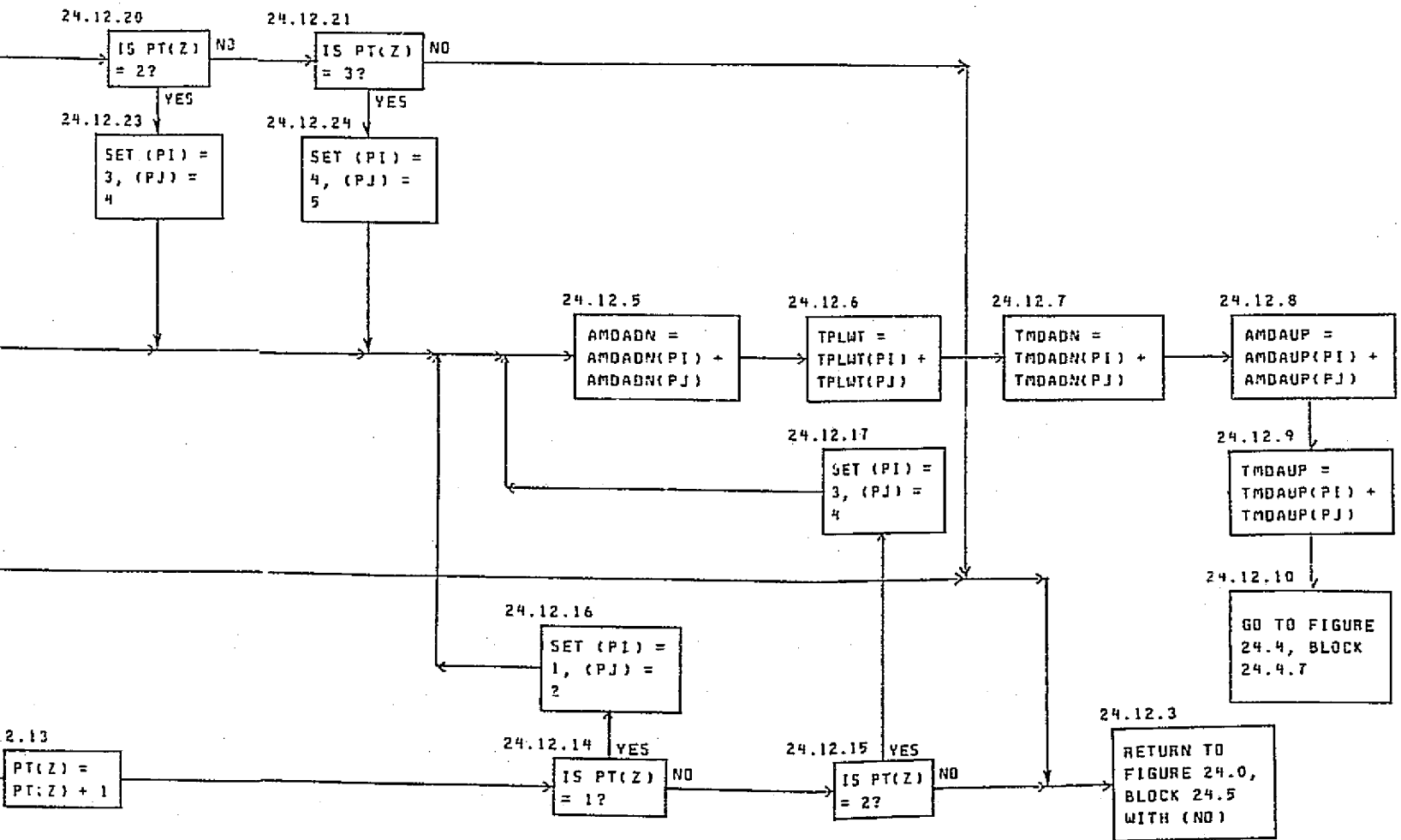

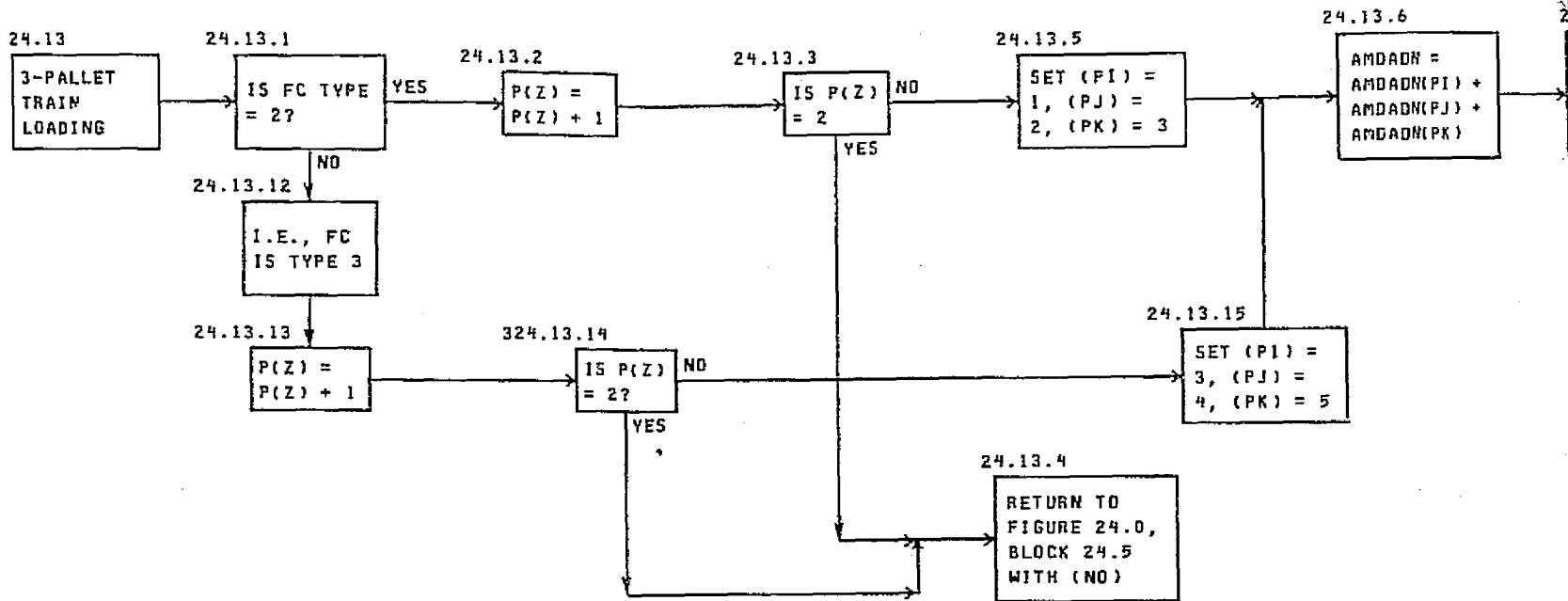

ORIGINAL PAGE IS
OF POOR QUALITY

OLDOUT FRAME |

FIGURE 24.13

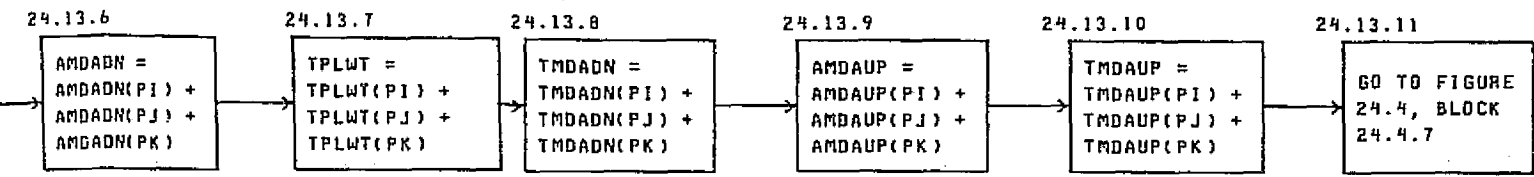

=
=
= 5

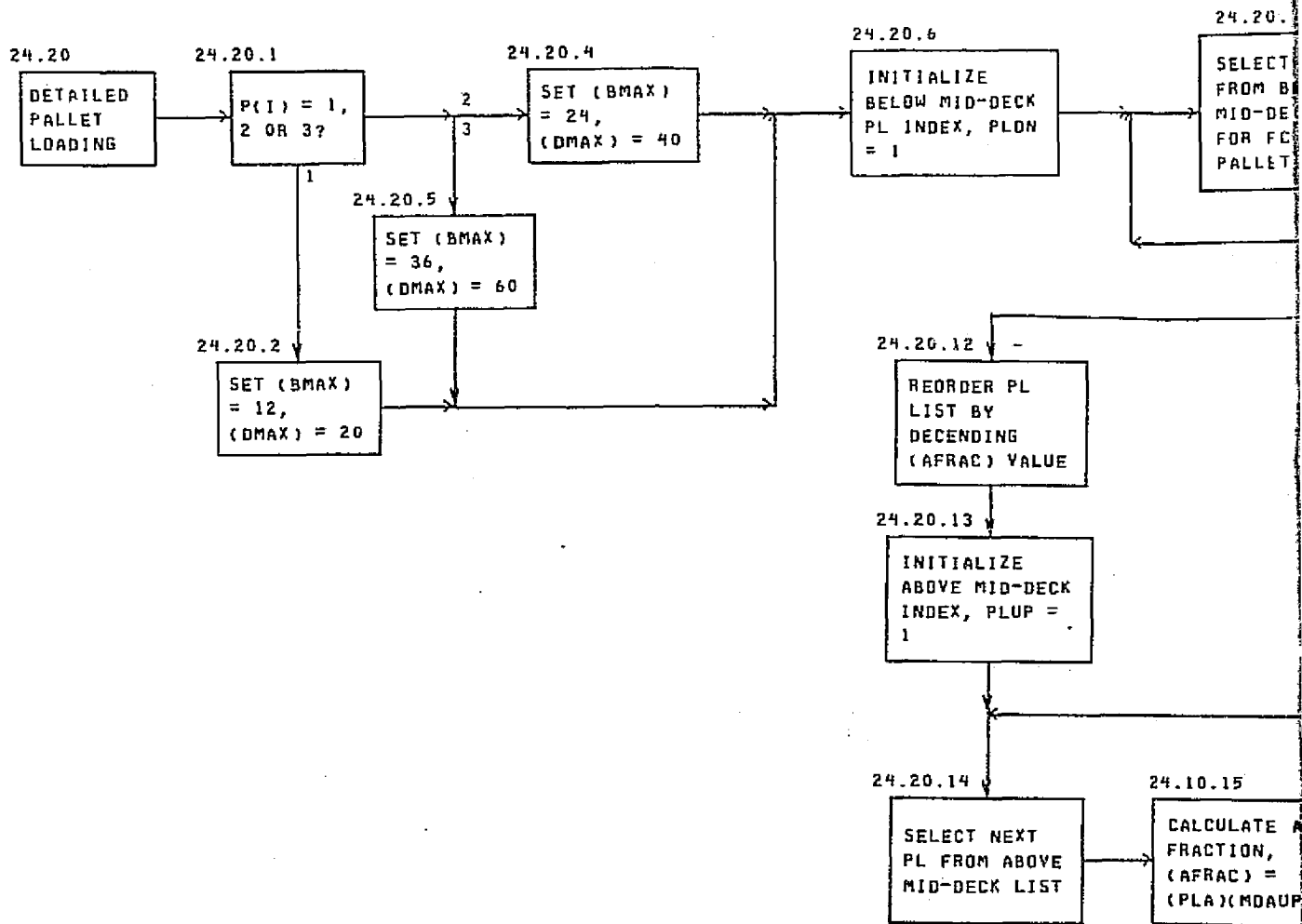

FOLDOUT FRAME 1

FIGURE 24.20

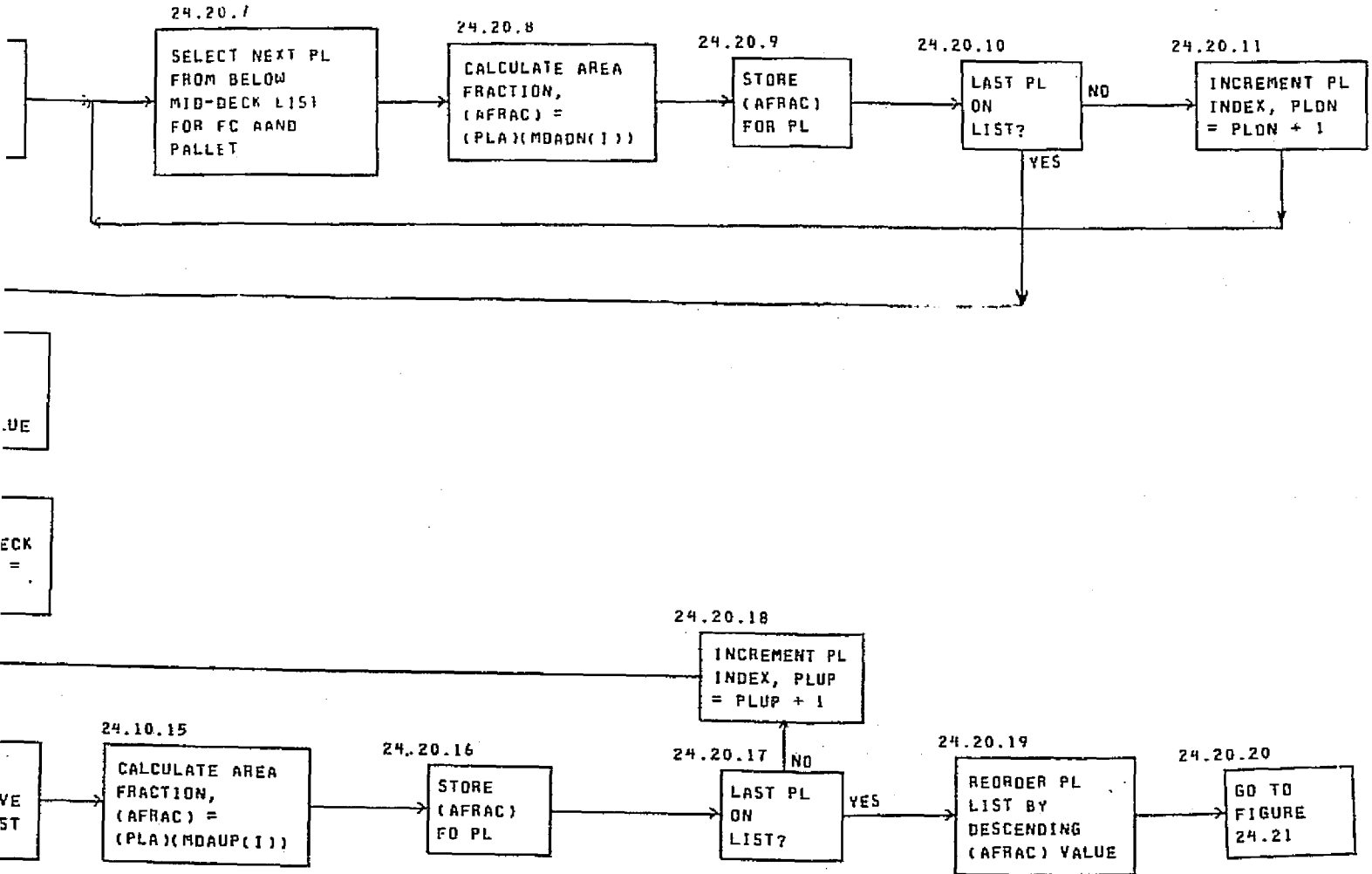

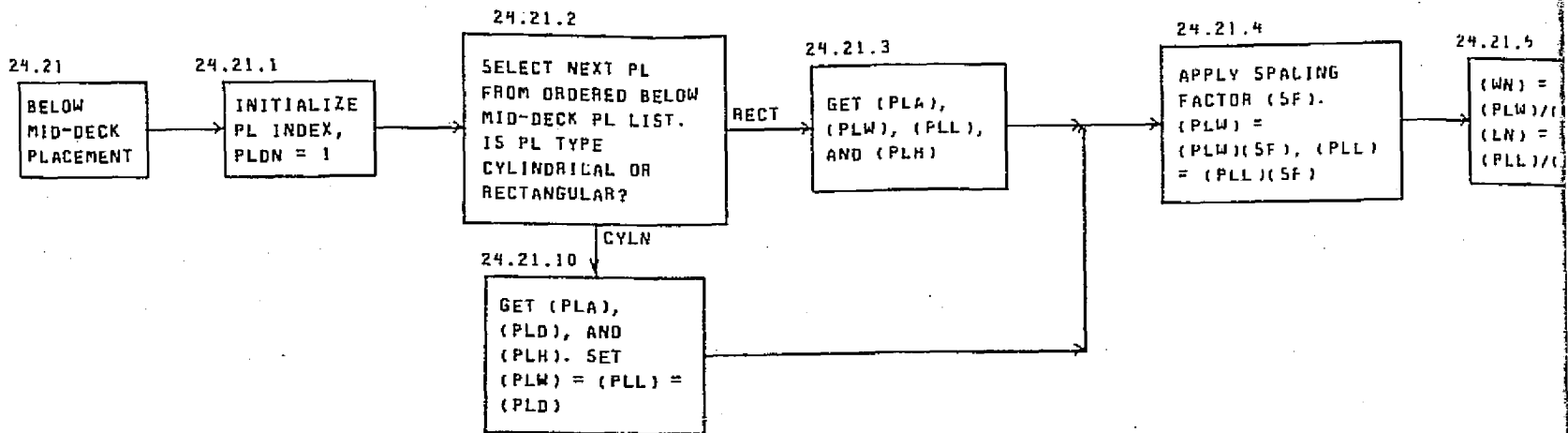

ORIGINAL PAGE IS
OF POOR QUALITY

OUT FRAME

FIGURE 24.21

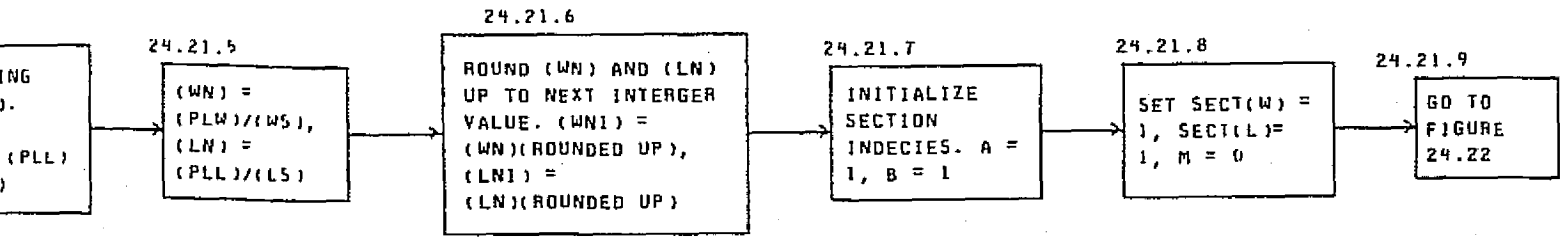

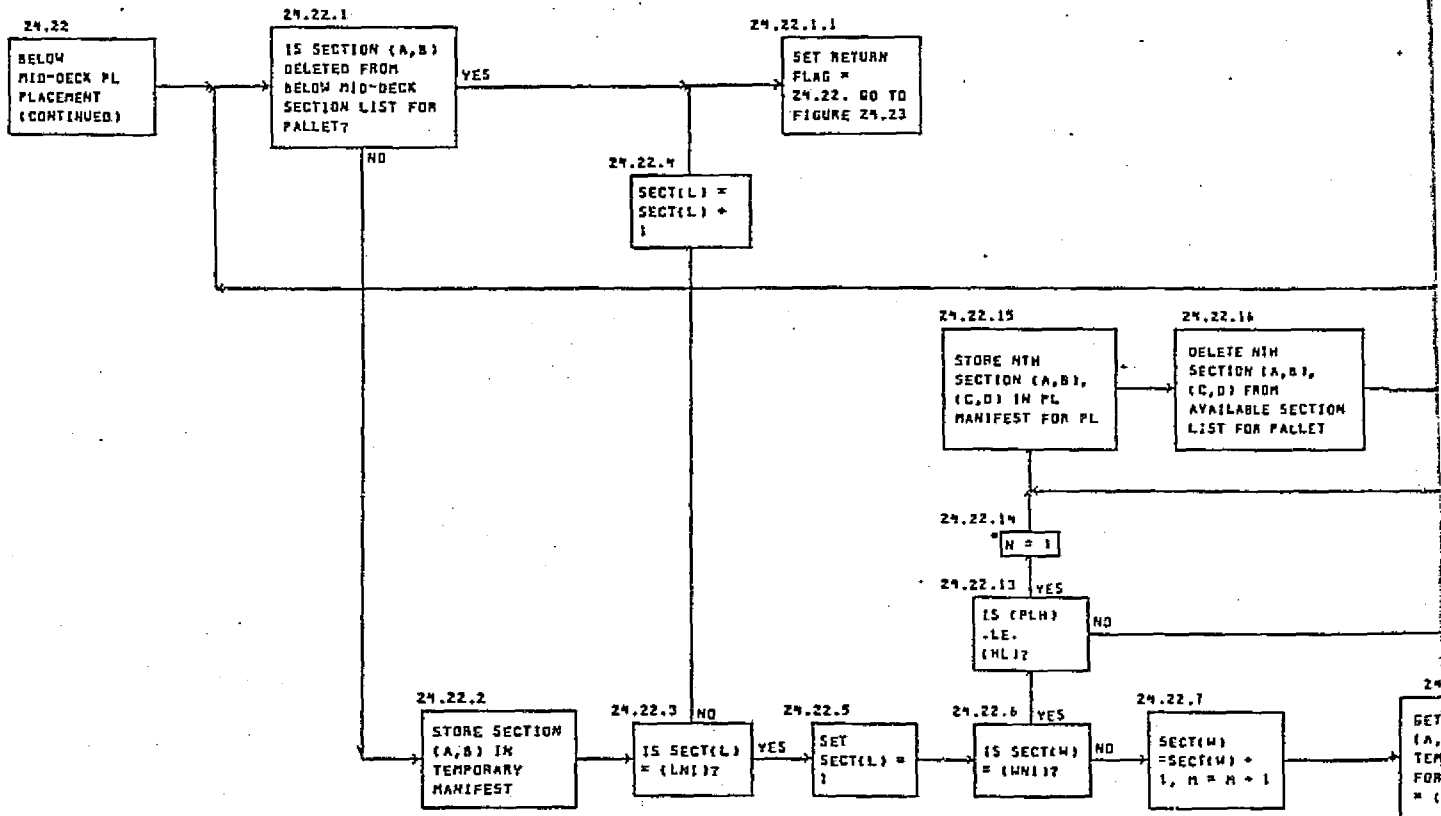

ORIGINAL PAGE IS
OF POOR QUALITY

WOLDOUT FRAME

MCDONNELL DOUGLAS

FIGURE 24.22

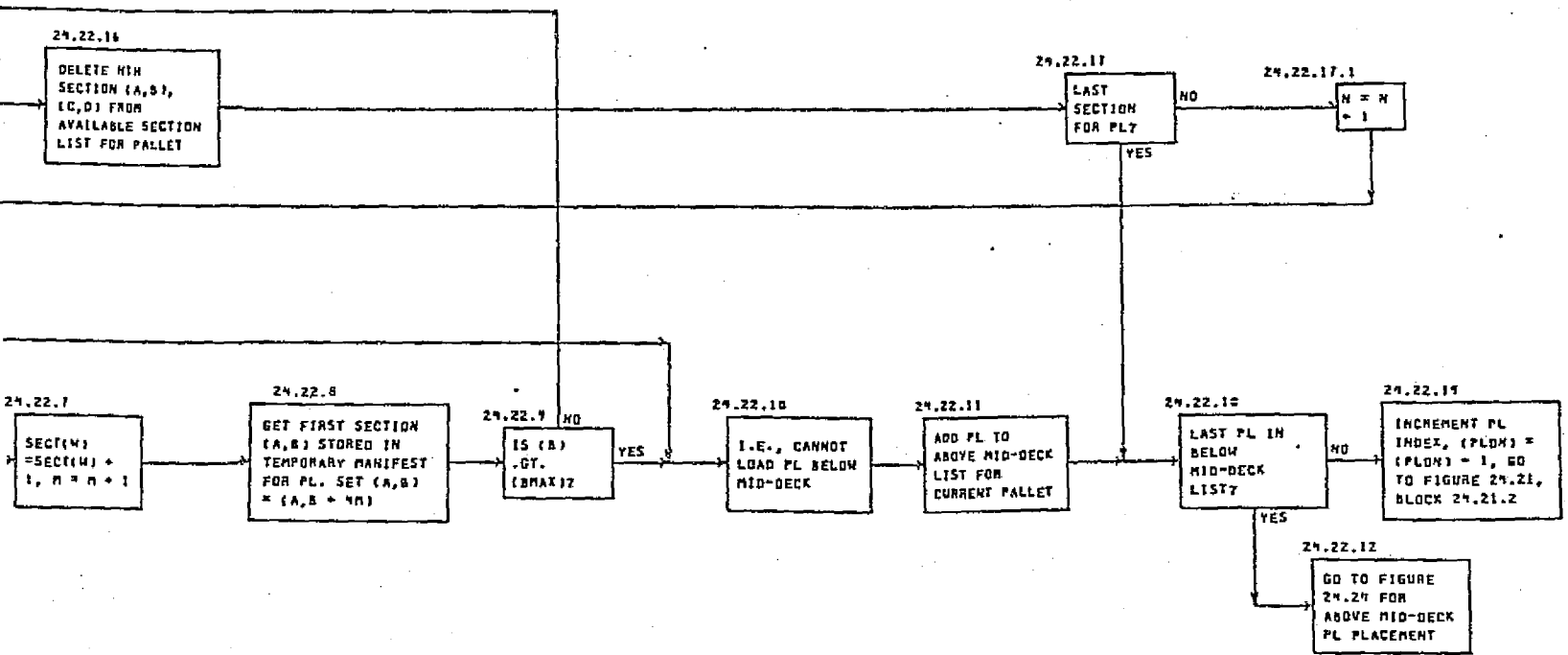

24.23
PALLET
SECTION INDEX
ROUTINE

24.23.1
IS P(I) =
1, 2 OR
3?

24.23.10
B =
16?

24.23.11
B =
20?

24.23.12
B =
24?

24.23.13
B =
28?

24.23.14
B =
32?

24.23.2
B =
4?

24.23.3
B =
8?

24.23.4
B =
12?

24.23.7
CLEAN TEMPORARY
SECTION
MANIFEST FOR

FOLDOUT TRAIN 1

MCDONNELL DOUGLAS



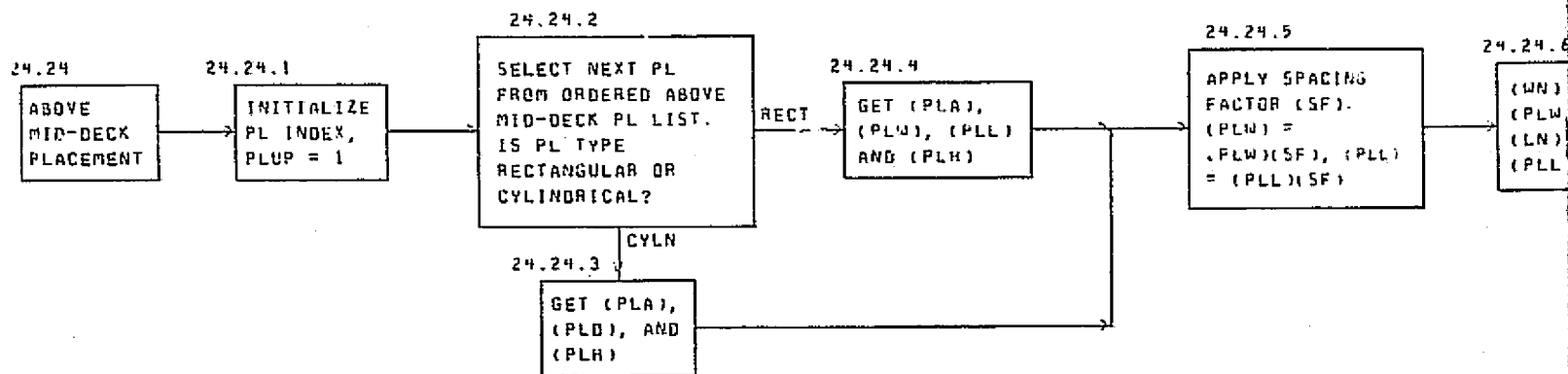

ORIGINAL PAGE IS
OF POOR QUALITY

GENCOE FRAME /

MCDONNELL DOUGLAS

FIGURE 24.24

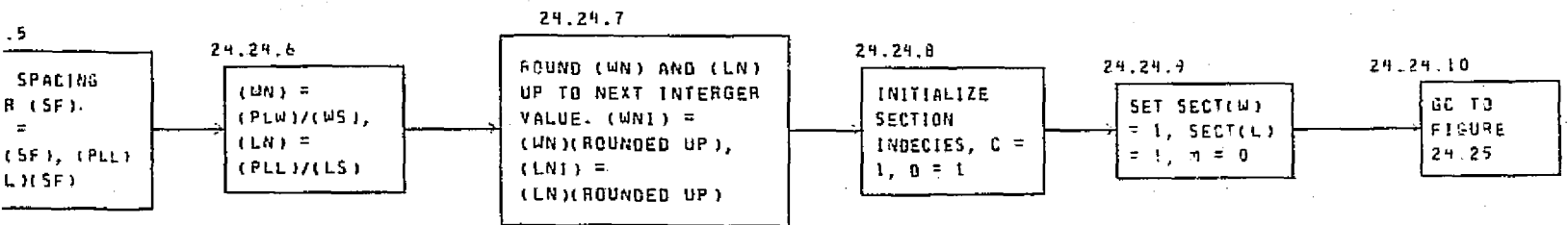

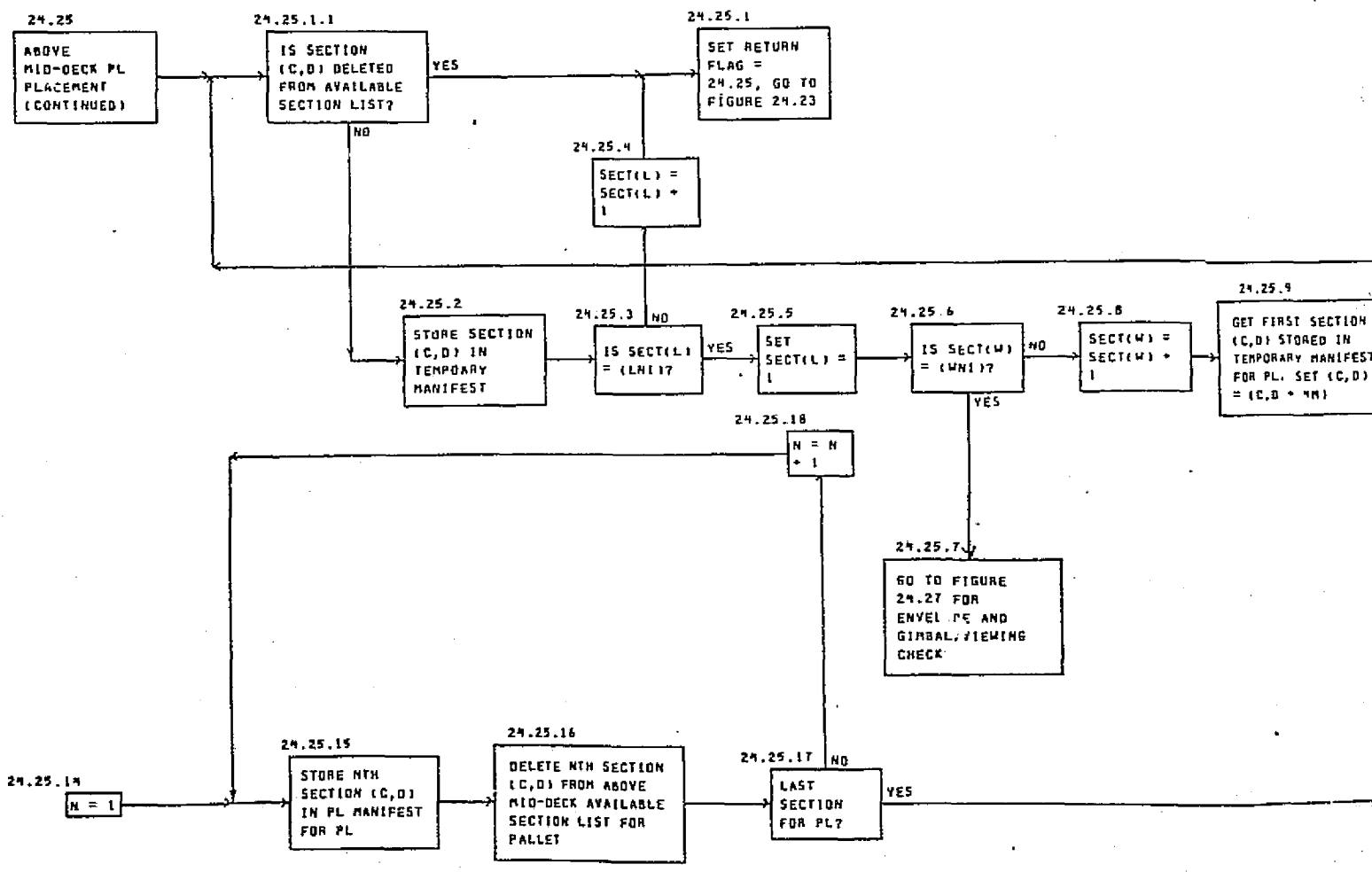

FOLDOUT FRAME

FIGURE 24.25

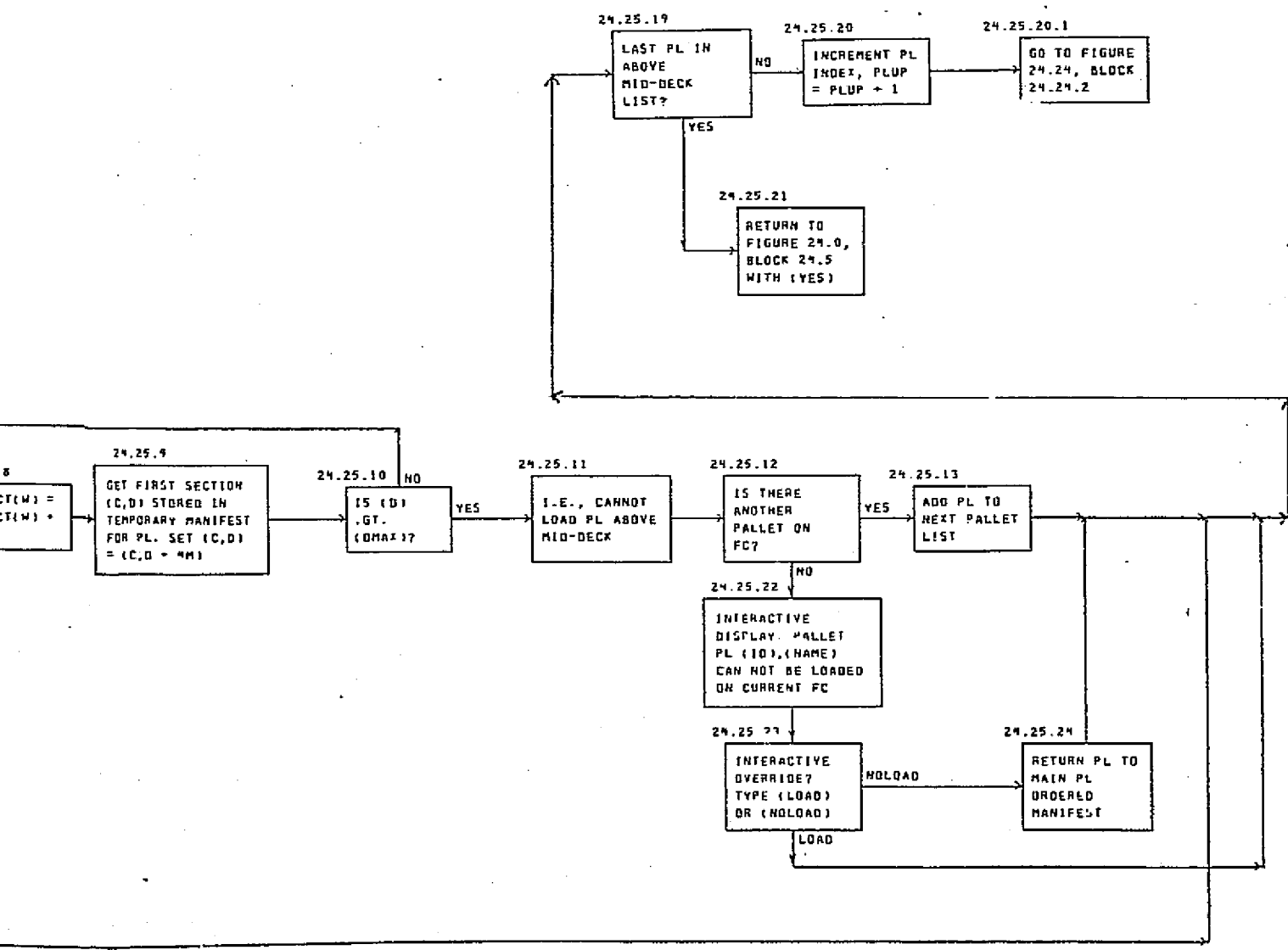

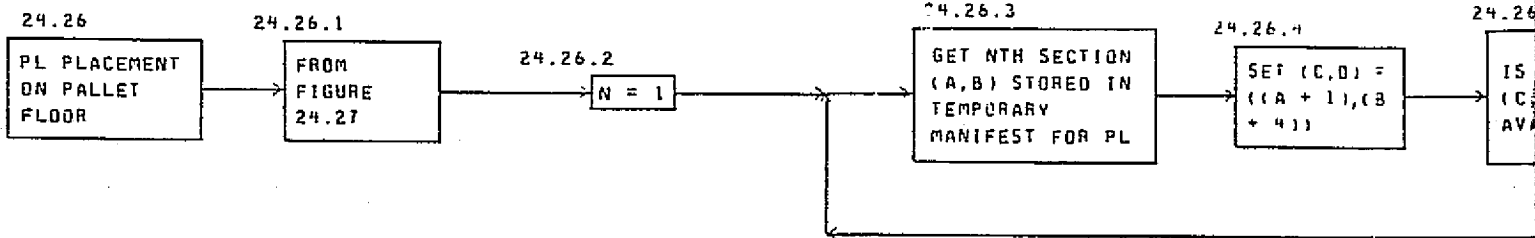

ORIGINAL PAGE IS
OF POOR QUALITY

BOLDOUT FRAME /

FIGURE 24.26

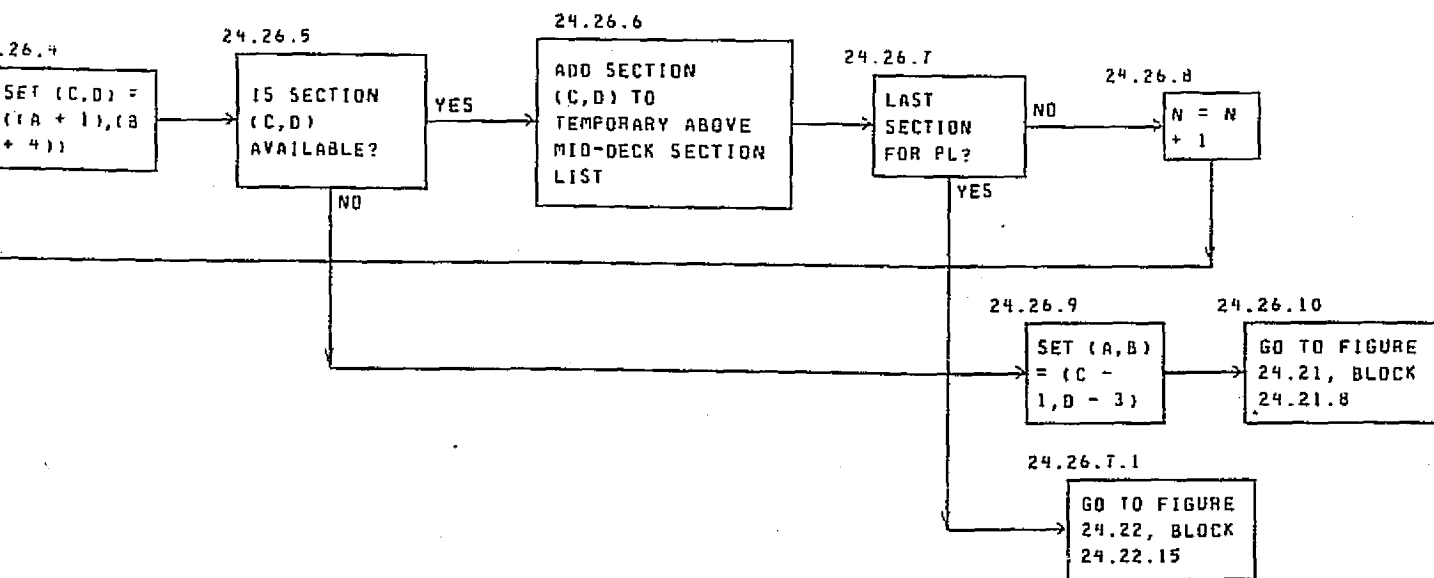

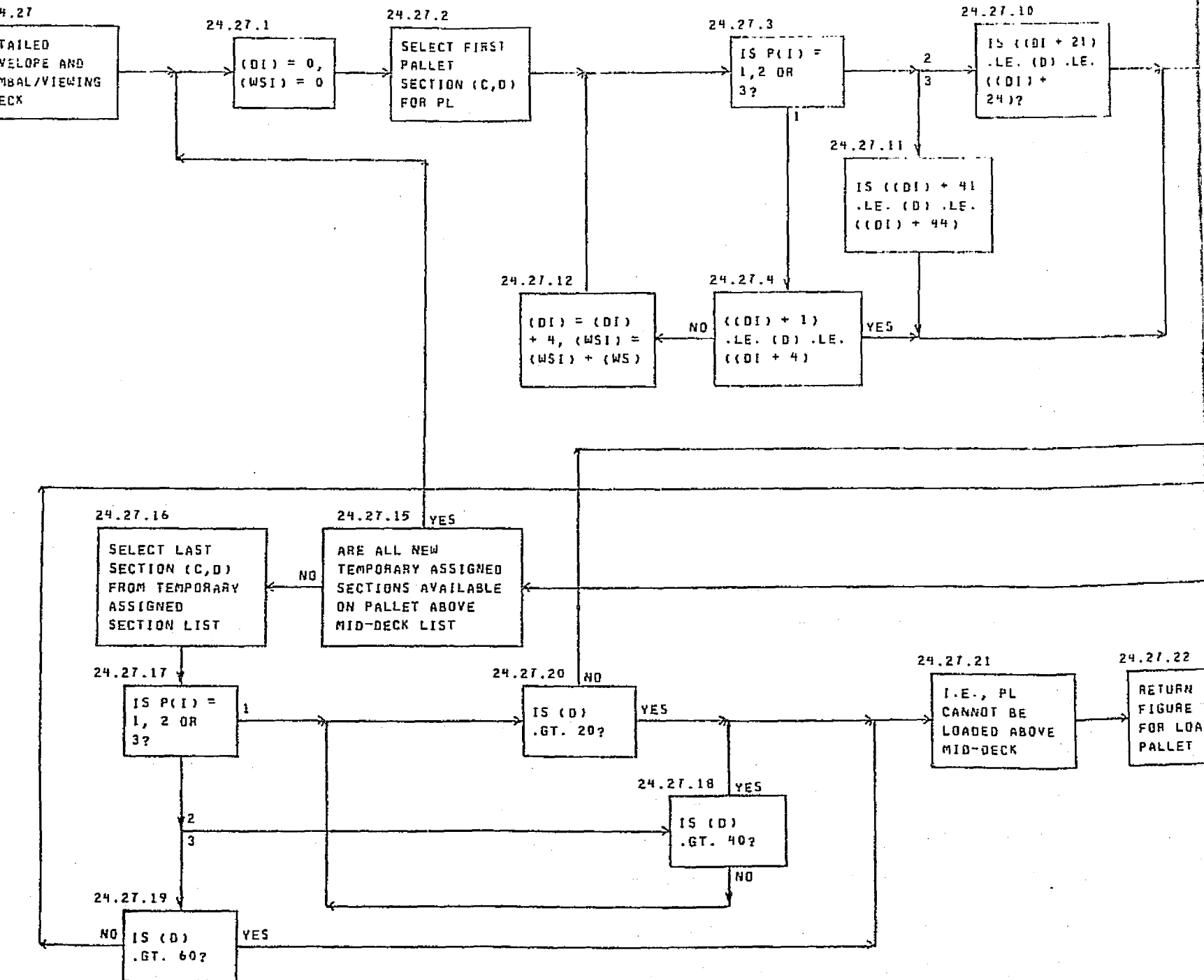

ORIGINAL PAGE IS
OF POOR QUALITY

MCDONNELL DOUGLAS
OUT FRAME

FIGURE 24.27

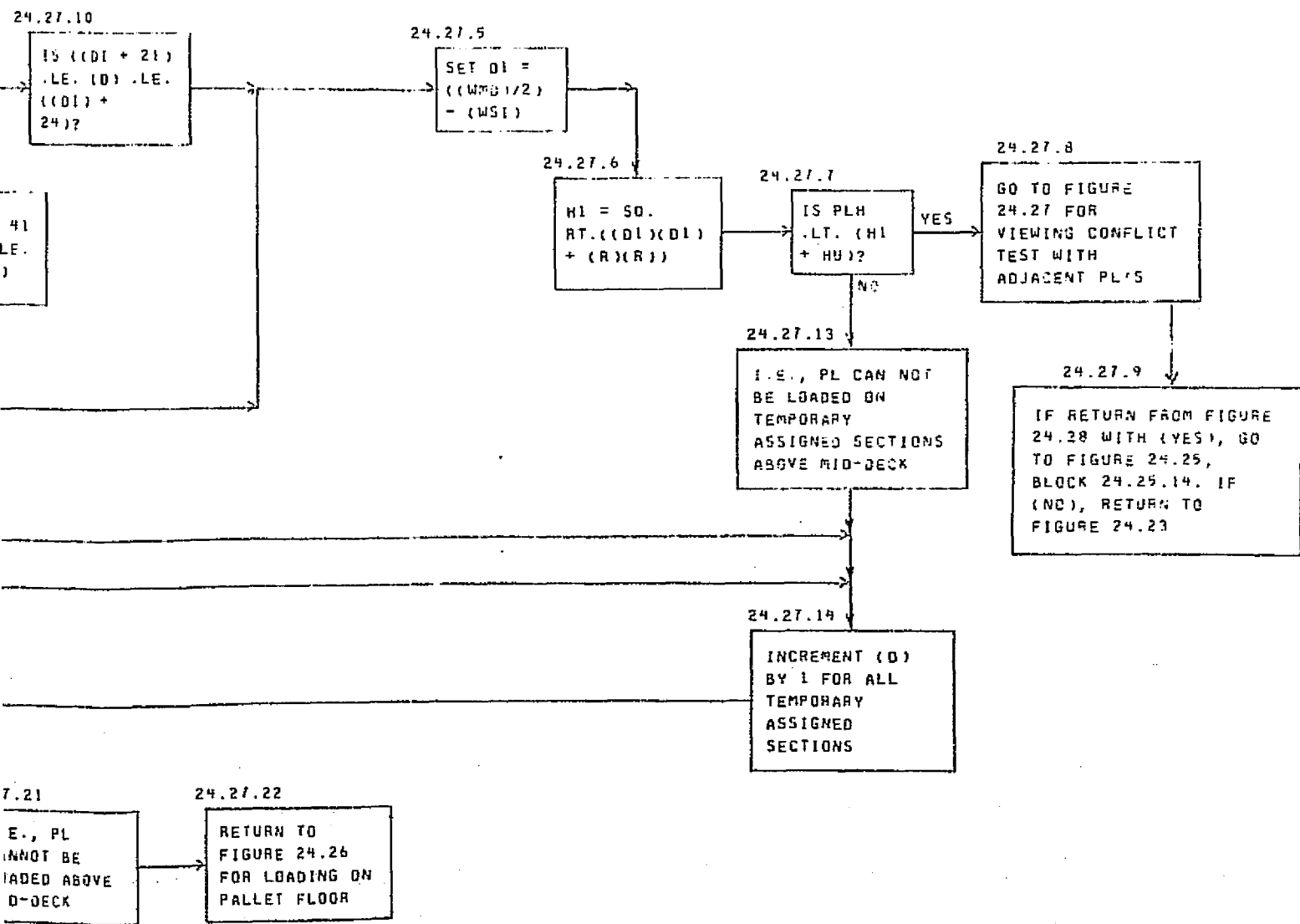

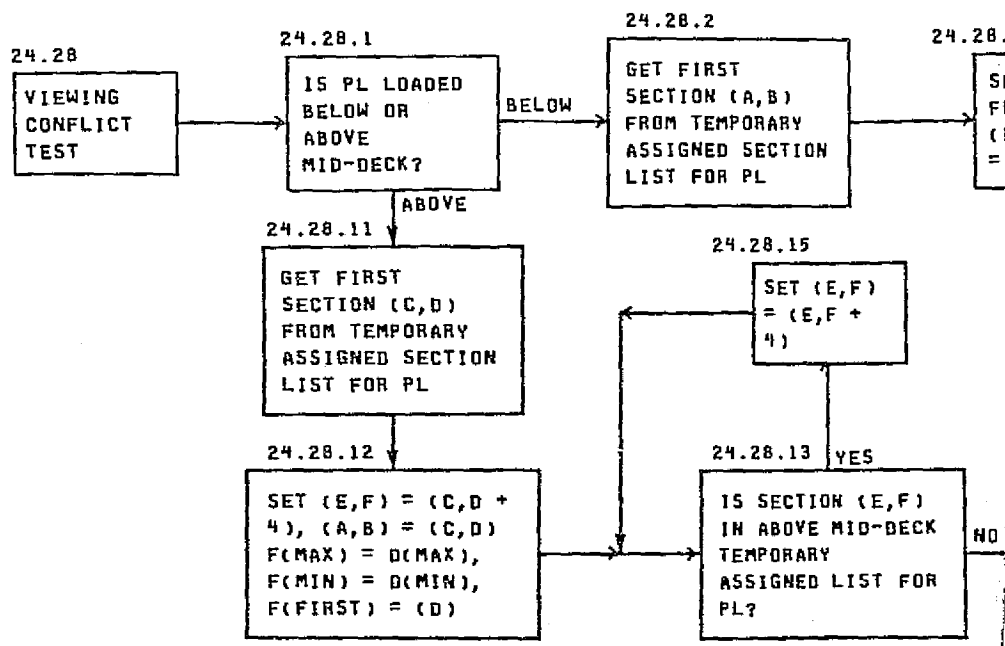

RECEIVED 11/17/77

FIGURE 24.28

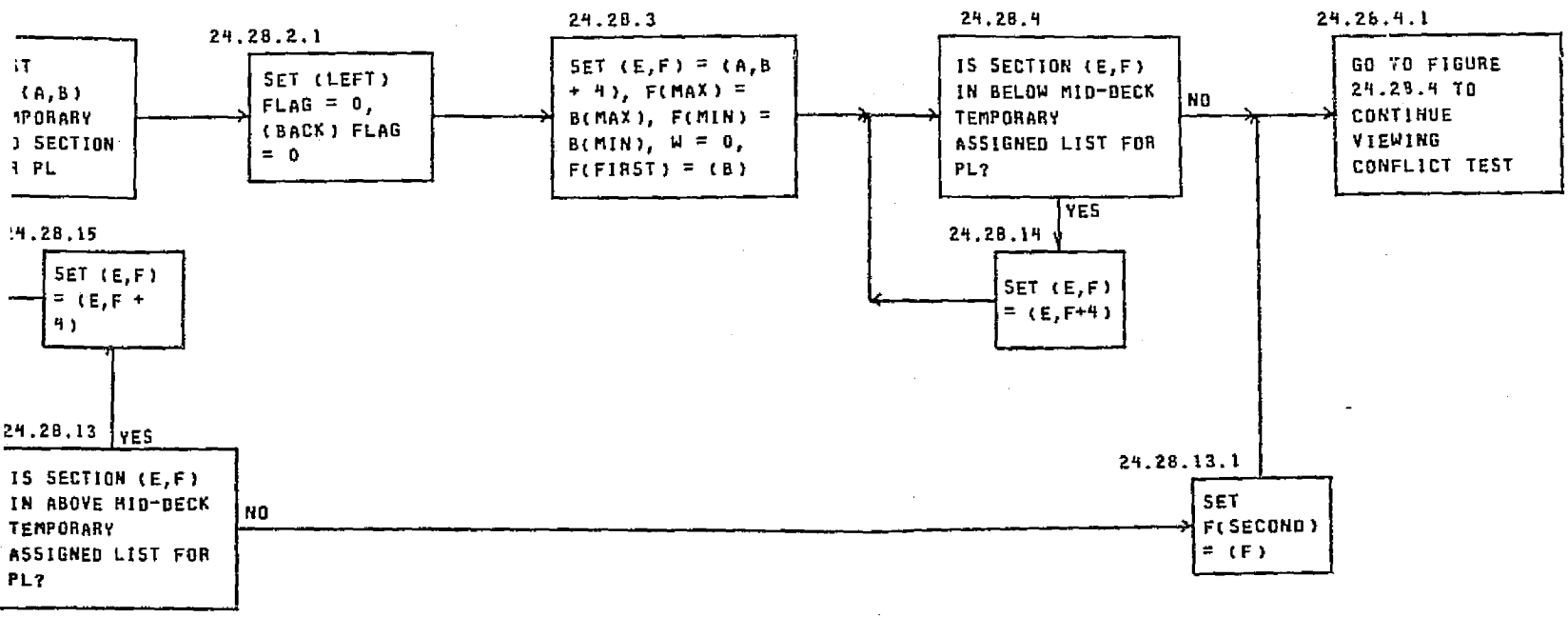

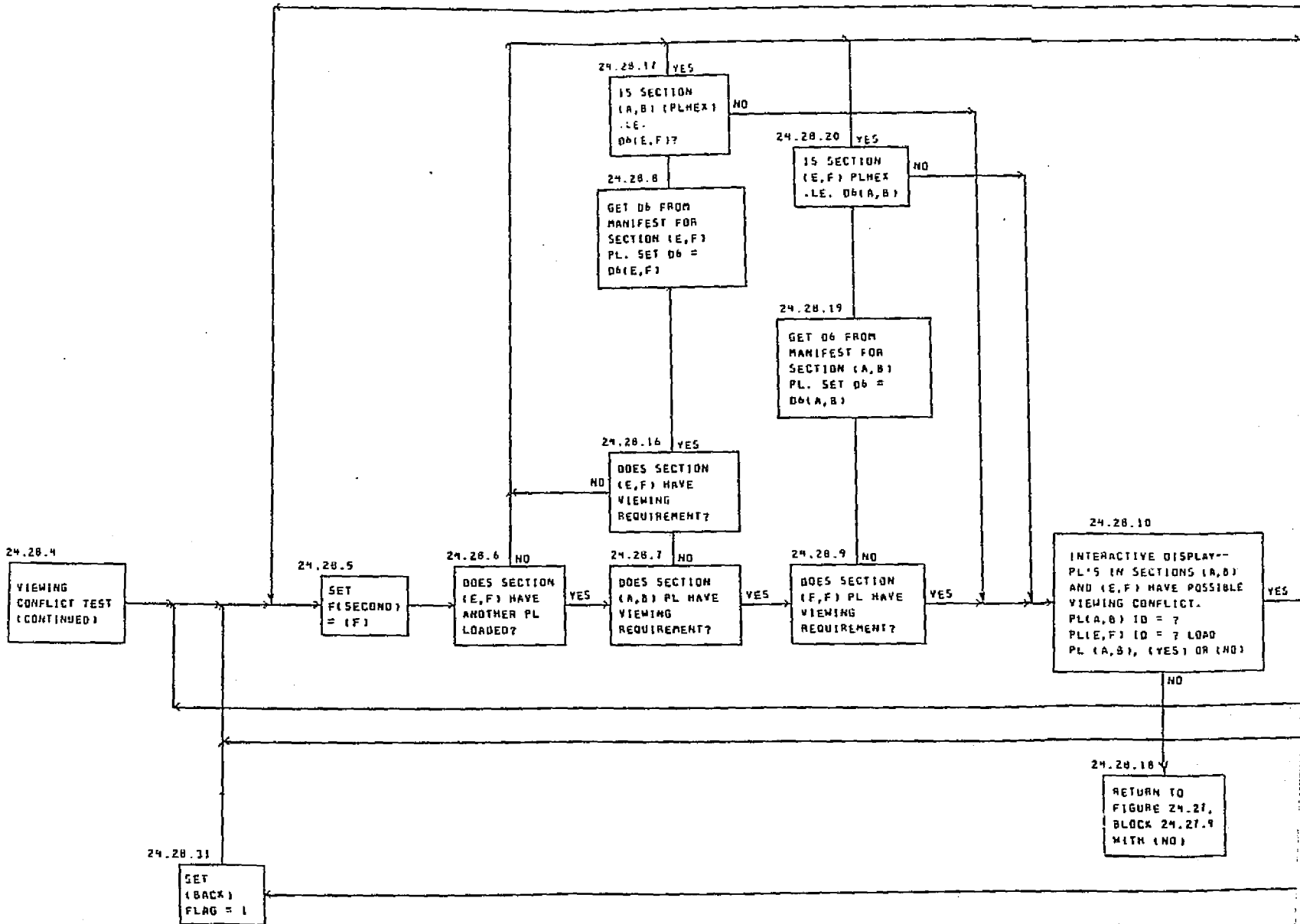

ORIGINAL PAGE IS OF POOR QUALITY

FOLDOUT FRAME

FIGURE 24.28.4

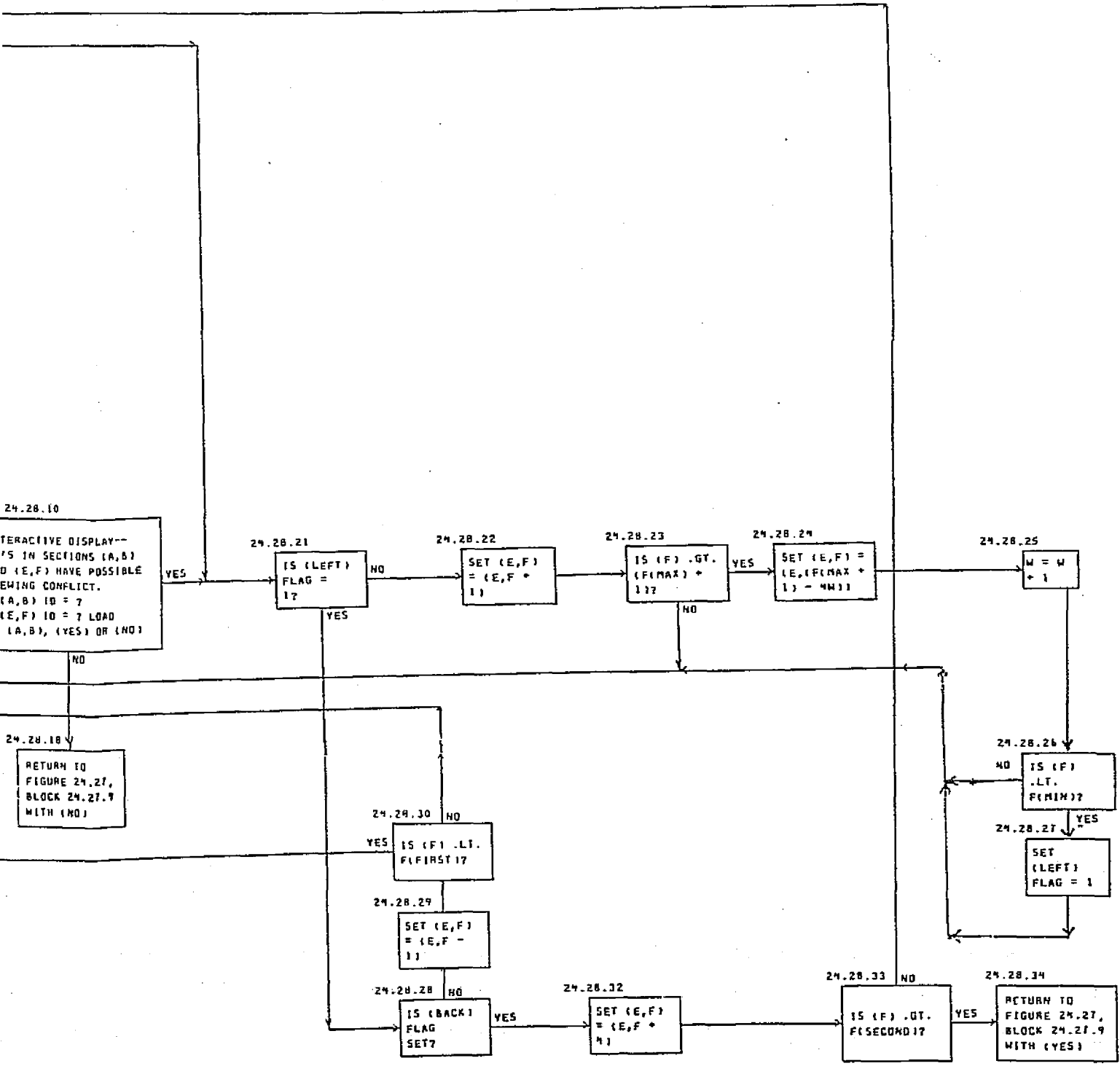

FOLDOUT FRAME

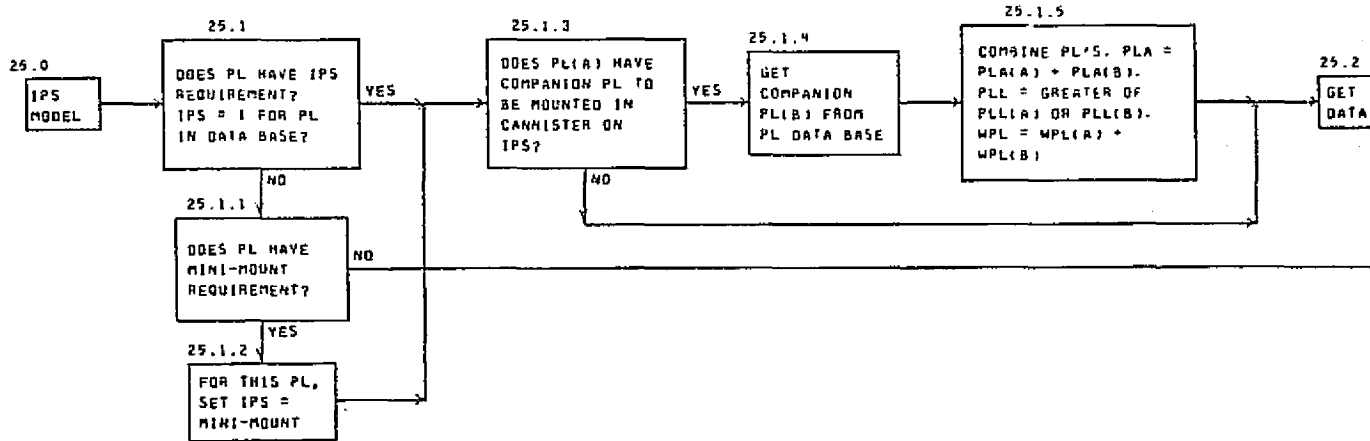

FOLDOUT FRAME

MCDONNELL DOUGLAS

FIGURE 25.0

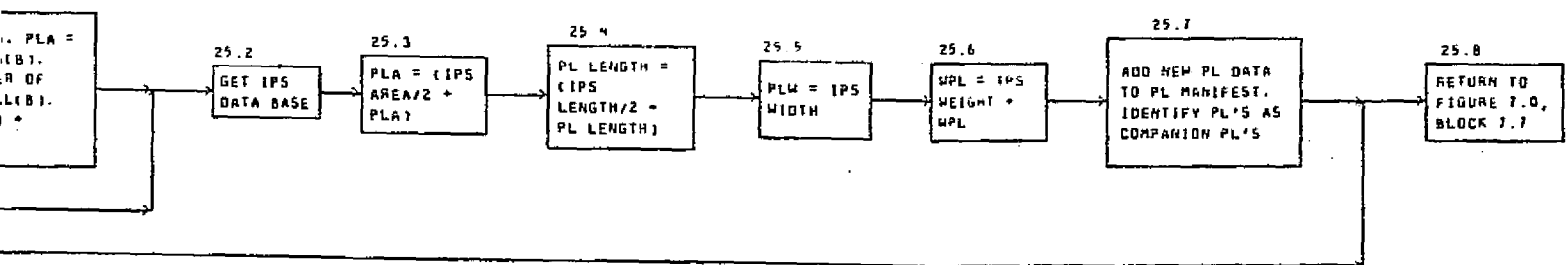

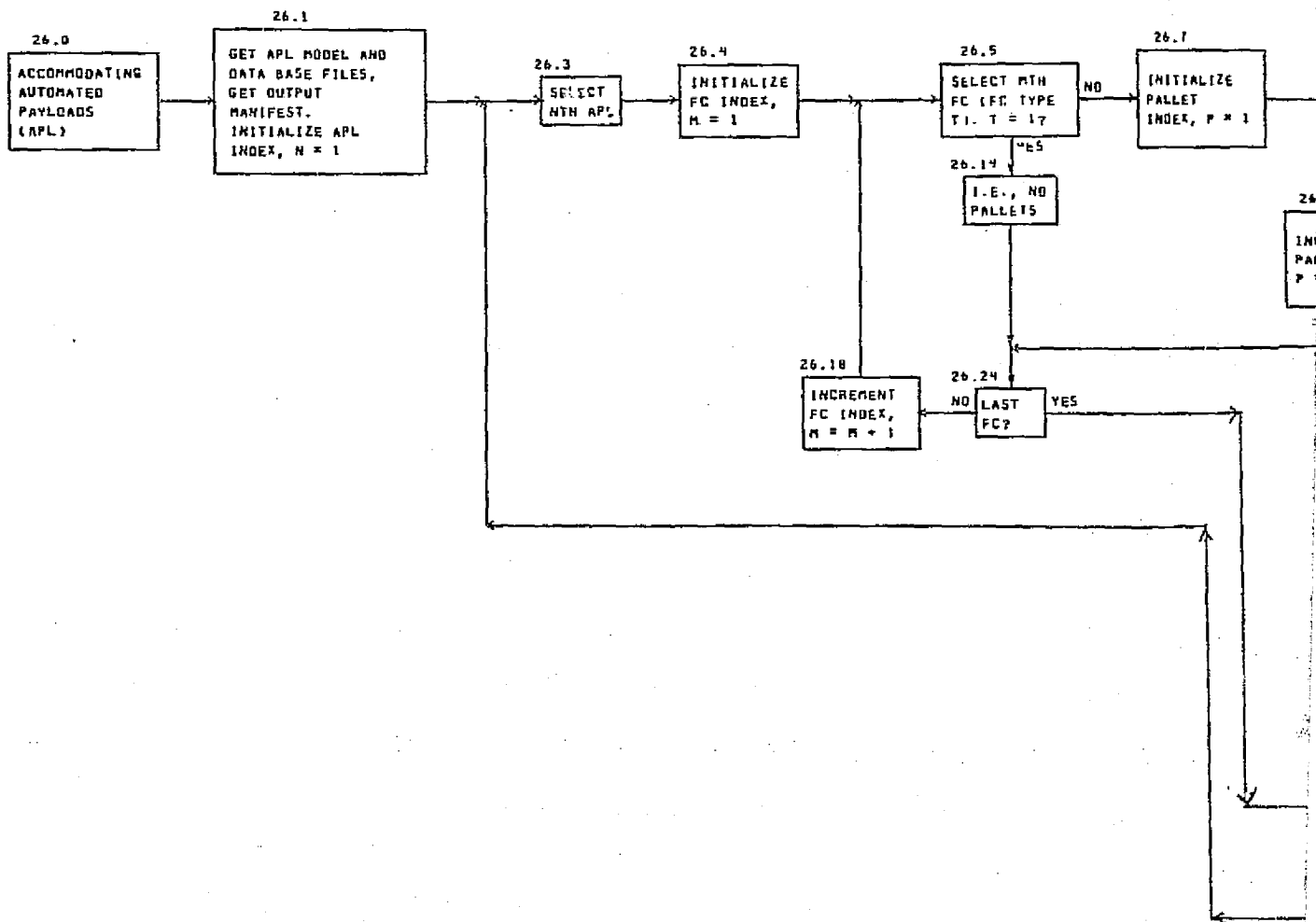

ORIGINAL PAGE IS
OF POOR QUALITY

FOLDOUT FRAME

FIGURE 26.0

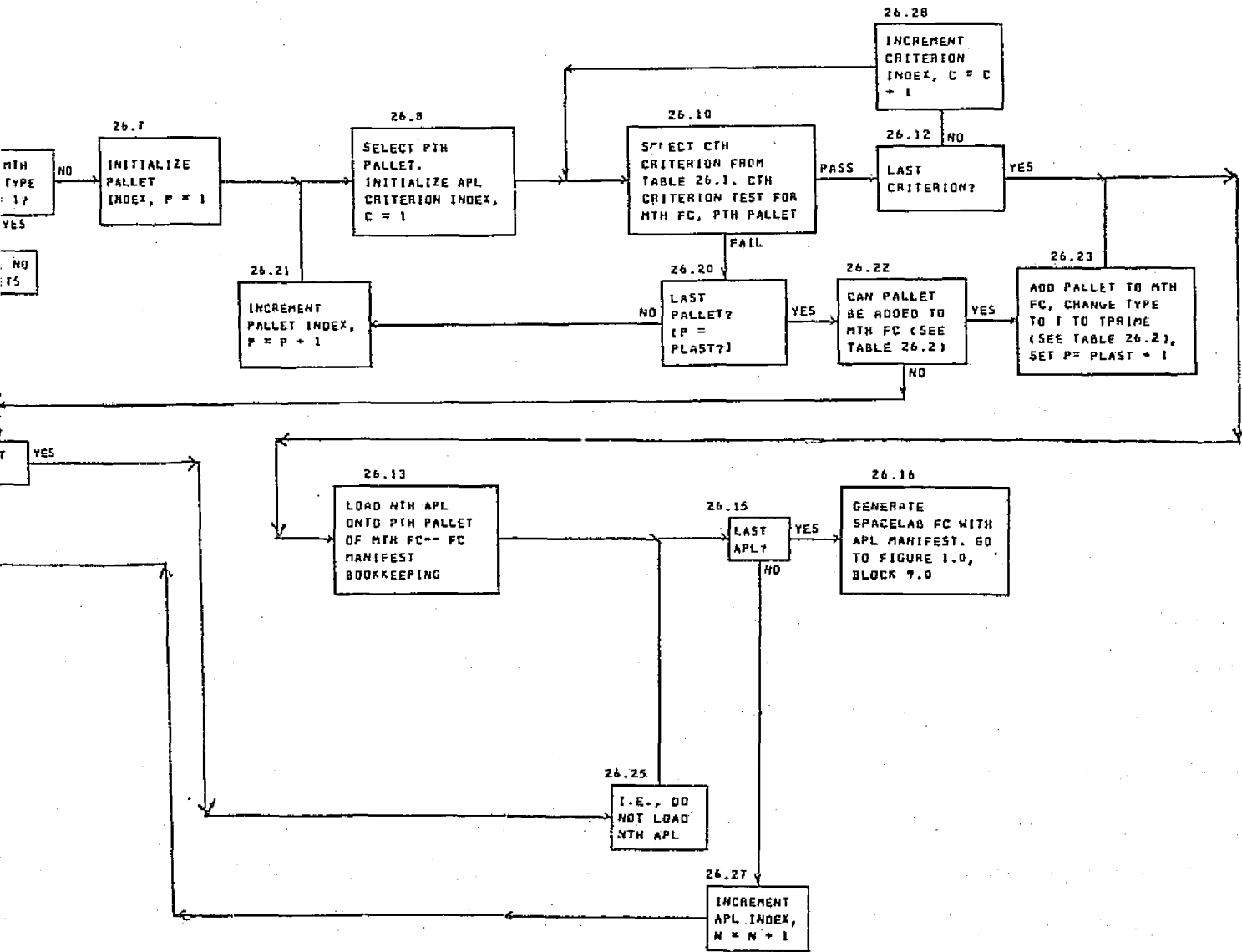

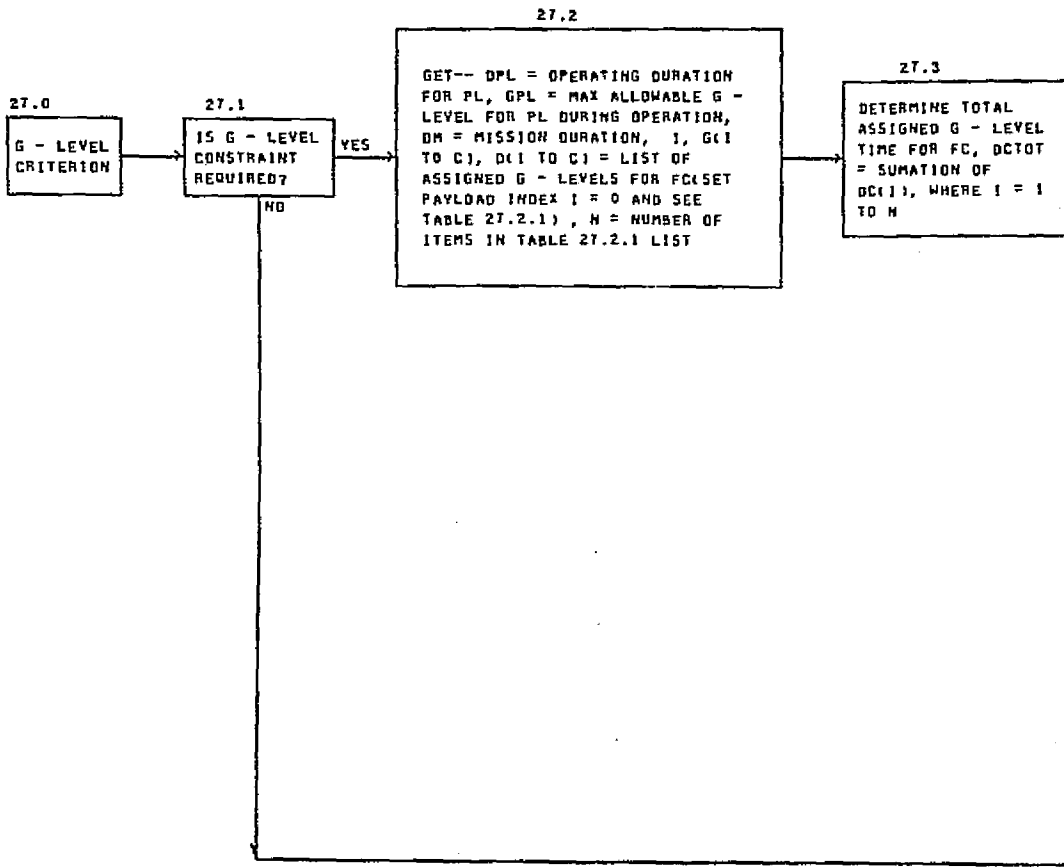

~~ORIGINAL FRAME~~
 MCDONNELL DOUGLAS

ORIGINAL PAGE IS
 OF POOR QUALITY
~~FOLEBOUT FRAME~~

FIGURE 27.0

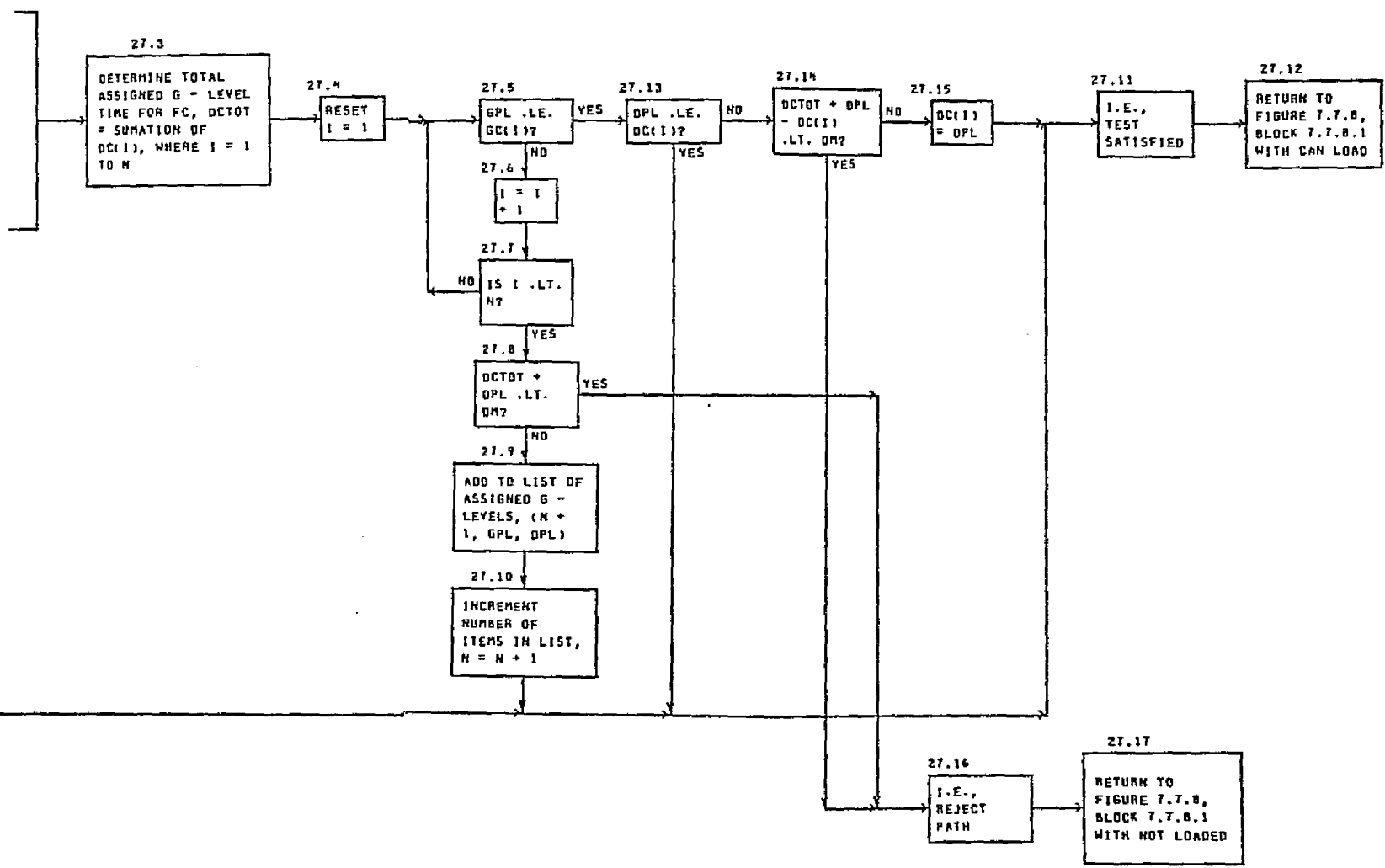

REVISIONS