

**NASA TECHNICAL
MEMORANDUM**

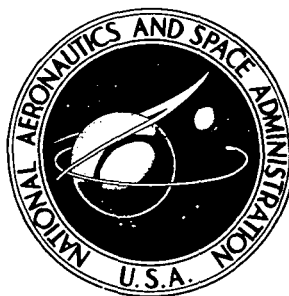

NASA TM X-3518

NASA TM X-3518

**CARBURIZATION AND HEAT TREATMENT
TO CAUSE CARBIDE PRECIPITATION
IN γ/γ' - δ EUTECTIC ALLOYS**

Surendra N. Tewari and Robert L. Dreshfield

Lewis Research Center

Cleveland, Ohio 44135

1. Report No. NASA TM X-3518	2. Government Accession No.	3. Recipient's Catalog No.	
4. Title and Subtitle CARBURIZATION AND HEAT TREATMENT TO CAUSE CARBIDE PRECIPITATION IN γ/γ' - δ EUTECTIC ALLOYS		5. Report Date May 1977	
		6. Performing Organization Code	
7. Author(s) Surendra N. Tewari and Robert L. Dreshfield		8. Performing Organization Report No. E-8976	
		10. Work Unit No. 505-01	
9. Performing Organization Name and Address Lewis Research Center National Aeronautics and Space Administration Cleveland, Ohio 44135		11. Contract or Grant No.	
		13. Type of Report and Period Covered Technical Memorandum	
12. Sponsoring Agency Name and Address National Aeronautics and Space Administration Washington, D. C. 20546		14. Sponsoring Agency Code	
		15. Supplementary Notes	
16. Abstract <p>In an attempt to improve their longitudinal shear strength, several directionally solidified γ/γ' - δ eutectic alloy compositions with minor element modifications were pack carburized and heat treated to provide selective carbide precipitation at the cell and grain boundaries. The directionally solidified Ni-17.8 Nb-6Cr-2.5Al-3Ta (weight percent) alloy was selected for the shear strength evaluation because it showed the shallowest δ-denuded zone at the carburized surface. The carburization - carbide precipitation treatment, however, did not appear to improve the longitudinal shear strength of the alloy.</p>			
17. Key Words (Suggested by Author(s)) Superalloys Carburizing Heat treatment Eutectic Directional solidification		18. Distribution Statement Unclassified - unlimited STAR Category 26	
19. Security Classif. (of this report) Unclassified	20. Security Classif. (of this page) Unclassified	21. No. of Pages 17	22. Price* A02

CONTENTS

	Page
SUMMARY	1
INTRODUCTION	2
EXPERIMENTAL PROCEDURE	3
Materials	3
Carburization and Heat Treatment	3
Mechanical Testing	3
RESULTS AND DISCUSSION	4
SUMMARY OF RESULTS	5
REFERENCES	6

CARBURIZATION AND HEAT TREATMENT TO CAUSE CARBIDE

PRECIPITATION IN $\gamma/\gamma' - \delta$ EUTECTIC ALLOYS

by Surendra N. Tewari* and Robert L. Dreshfield

Lewis Research Center

SUMMARY

In an attempt to improve the longitudinal shear strength of directionally solidified $\gamma/\gamma' - \delta$ eutectic alloys, carbide particles were selectively precipitated at the cell and grain boundaries by using a carburization - carbide precipitation treatment.

Directionally solidified $\gamma/\gamma' - \delta$ eutectic alloys with nominal composition (weight percent) of Ni-20Nb-6Cr-2.5Al, Ni-18.6Nb-6Cr-2.5Al-0.87Ti, Ni-19.7Nb-6Cr-2.5Al-1W, Ni-19.7Nb-6Cr-2.5Al-1Mo, and Ni-17.8Nb-6Cr-2.5Al-3Ta were given a treatment consisting of pack carburizing (6 hr/1065^o C) plus solutioning (4 hr/1210^o C) plus aging (24 hr/870^o C). This resulted in selective precipitation of rounded carbide particles to a depth of about 0.01 cm at the cell and grain boundaries. The alloy containing 3-wt% Ta showed the shallowest δ -denuded zone (a zone depleted of Nb). It was selected for the shear strength evaluations because δ is the strengthening phase in $\gamma/\gamma' - \delta$ eutectic alloys.

A carburization - carbide precipitation treatment consisting of carburization (20 hr/1093^o C) plus solutioning (24 hr/1210^o C) plus aging (24 hr/870^o C) given to the alloy containing 3-wt% Ta resulted in a carbide precipitation depth of about 0.03 cm. After the δ -denuded zone was removed by machining, the specimens were tested in longitudinal shear at 760^o C. Cracking along the cell and grain boundaries was the failure mode in the alloy containing carbide precipitates. However, the carbide precipitation treatment did not appear to improve the alloy's longitudinal shear strength.

*National Research Council - National Aeronautics and Space Administration
Research Associate.

INTRODUCTION

Directionally solidified (DS) eutectic alloys are presently being considered as a next-generation material for aircraft gas turbine blades. Their use is expected to result in significant engine performance advantages due to a potential 50° to 100° C increase in allowable metal temperatures over superalloys (ref. 1). This in turn could result in reduced fuel consumption and engine weight. One such alloy presently under intensive investigation is a DS $\gamma/\gamma' - \delta$ eutectic alloy. Its microstructure consists of alternating γ , Ni solid-solution lamellae containing γ' , Ni_3Al precipitates and δ , Ni_3Nb lamellae. A $\gamma/\gamma' - \delta$ eutectic alloy with the nominal composition of Ni-20Nb-6Cr-2.5Al (weight percent) has been shown to have very good tensile and stress-rupture properties (ref. 2). However, the alloy was found lacking in longitudinal shear strength and transverse ductility (ref. 3).

Adequate longitudinal shear strength at intermediate temperatures (535° to 760° C) is particularly needed in the root attachment section of a turbine blade. This shear strength is required to carry the centrifugal load of the blade where it is connected to the disk. In aircraft gas turbines the disk attachment is typically shaped like a fir tree, and the shear stress across the tangs can be substantial.

Directionally solidified $\gamma/\gamma' - \delta$ eutectic alloys have failed along the cell and grain boundaries when tested in longitudinal shear (ref. 3). In the past, significant grain boundary strengthening has been obtained in conventional superalloys by precipitating carbide particles at the grain boundaries (ref. 4). This investigation was undertaken to see if adding carbon in the solid state and subsequently heat treating would cause carbide particles to selectively precipitate at the cell and grain boundaries in order to improve the shear strength of a DS $\gamma/\gamma' - \delta$ eutectic alloy at blade-root temperatures.

Several $\gamma/\gamma' - \delta$ eutectic alloys with minor element modifications were pack carburized and heat treated to provide carbide precipitation at the cell and grain boundaries. The 3-wt% Ta composition was selected for longitudinal shear strength measurements at 760° C. Sheffler (ref. 5) investigated the effect that carbon additions made to the melt had on the longitudinal shear strength of $\gamma/\gamma' - \delta$. The present investigation was performed concurrently with that reported in reference 5 to evaluate the potential of making carbon additions after the alloy was solidified. The properties reported in this investigation are for an alloy that was partially cellular, while that of reference 5 was fully aligned.

EXPERIMENTAL PROCEDURE

Materials

Bars 8 cm long by 1.3 cm in diameter of directionally solidified $\gamma/\gamma' - \delta$ eutectic alloys with the nominal composition (in weight percent) of Ni-20Nb-6Cr-2.5Al, Ni-18.6Nb-6Cr-2.5Al-0.87Ti, Ni-19.7Nb-6Cr-2.5Al-1W, Ni-19.7Nb-6Cr-2.5Al-1Mo, and Ni-17.8Nb-6Cr-2.5Al-3Ta were obtained from United Technologies Corporation Research Laboratories. The alloys studied in this investigation were prepared as a part of the program reported in reference 3. These alloys were directionally solidified at 3 cm/hr in a Bridgman furnace having a temperature gradient in excess of 200° C/cm at the solid-liquid interface (ref. 2).

Carburization and Heat Treatment

Based on preliminary studies that correlated time, temperature, and diffusion depth, one specimen of each composition was pack carburized in a commercial pack-carburizing compound¹ for 6 hours at 1065° C and cooled to room temperature in the box. These were then solution annealed (4 hr/1210° C) and aged (24 hr/870° C) in a flowing argon atmosphere. The specimens were air cooled to room temperature following the aging treatment. These specimens were used for microstructural screening of the depth of the carbon attack during carburizing and the subsequent depth and location of carbide precipitation resulting from heat treatment of different-composition alloys. Based on these results a treatment consisting of carburization (20 hr/1093° C) plus solutioning (24 hr/1210° C) plus aging (24 hr/870° C), which provided a greater depth of carbide precipitation, was used to investigate the effect of carburization - carbide precipitation treatment on the longitudinal shear strength of the alloy containing 3-wt% Ta.

Mechanical Testing

Longitudinal (parallel to the alloy growth direction) shear tests were conducted in air at 760° C on the specimens ground to the dimensions shown in figure 1(a).

¹Quicklite 'A', registered trademark of E. F. Houghton and Company.

The shear thickness of this sample was thought to be representative of the shear thicknesses of tangs in the root attachments of gas turbine blades. Prior to the carburization, the specimens were machined 0.012 cm oversize to the dimension in figure 1(a). MarM-200 alloy button-headed grips (fig. 1(b)) were used on the button-headed (shear test) end of the specimen, and taper-headed grips were used on the other end. The specimens failed in longitudinal shear at the button-headed end, which came off like a thick washer (fig. 2).

RESULTS AND DISCUSSION

Figure 3 shows the effect of the preliminary carburization - carbide precipitation treatment on the microstructure (transverse to the growth direction) of DS $\gamma/\gamma' - \delta$ eutectic alloys. As mentioned previously, the alloy microstructure consists of alternating γ lamellae containing γ' precipitates and δ lamellae. However, the alloys were not perfectly lamellar and contained about 25-volume-percent cellular regions that were elongated in the growth direction. The carburization - carbide precipitation treatment results in a δ -denuded zone at the specimen surface. This δ -denuded zone is believed to occur because of niobium carbide formation near the surface and resultant niobium diffusion toward the specimen surface, where it reacts with carbon from the carburizing compound. The depth of the δ -denuded zone varies from about 0.011 cm for the 1-wt% Mo alloy to about 0.001 cm for the 3-wt% Ta alloy. Carbide particles were observed to preferentially precipitate at the cell and grain boundaries (fig. 3). No carbide precipitation was observed in the lamellar regions. Carbide precipitates decorating the cell and grain boundaries were observed to a depth of about 0.01 cm for 3-wt% Ta alloy (fig. 3(e)).

To increase this depth of carbide precipitation, a treatment consisting of carburization (20 hr/1093^o C) plus solutioning (24 hr/1210^o C) plus aging (24 hr/870^o C) was used. This increased the carbide precipitation depth to about 0.03 cm. However, it also resulted in a δ -denuded zone of about 0.006 cm at the surface. This zone was ground off before mechanical testing of the carburized-alloy shear specimens.

The distribution and appearance of these carbide precipitates is more clearly shown in an SEM micrograph (fig. 4(a)). Rounded carbide particles decorate the cell and grain boundaries. These particles caused the elimination of δ lamellae in

their immediate vicinity. The regions near the cell boundaries where δ plates previously existed can be clearly seen in this figure. These carbides were observed to be rich in niobium, as is evident in figure 4(b), which shows an electron-microprobe line traverse across typical carbide particles. Carbon, niobium, and tantalum intensity build up when the carbide particles pass under the beam, as shown in this figure.

Longitudinal shear strengths of the alloys were determined by dividing the load to failure by the cylindrical area along which the failure occurred. The average shear strength of about 283 MPa (table I) observed for the uncarbided, Ni-20Nb-6Cr-2.5Al, $\gamma/\gamma' - \delta$, DS eutectic alloy at 760^o C was nearly the same as the value reported by Lemkey and McCarthy for this alloy (ref. 3). The 760^o C shear strength of about 313 MPa obtained for as-DS, 3-wt% Ta $\gamma/\gamma' - \delta$ eutectic alloy, however, is slightly less than the 352 MPa reported by Lemkey and McCarthy (ref. 3). Figure 5(a) shows, for the DS, 3-wt% Ta $\gamma/\gamma' - \delta$ alloy, a transverse section of the region that failed in longitudinal shear. As mentioned previously, the DS $\gamma/\gamma' - \delta$ eutectic alloy fails along the cell and grain boundaries.

Shear strengths of 323 and 258 MPa (table I) obtained for the carburized specimens were not considered an improvement over the 313 MPa obtained for the as-DS alloy. The microstructural appearance of the failure in the carburized alloy is shown in figure 5(b). The bottom surface of the failed button head was slightly polished and lightly etched to reveal the microstructure. Again cracks follow the cell and grain boundaries. The carbide particles apparently are not effective in altering the crack path and thus did not appear to provide strengthening.

This testing procedure, however, was limited in sensitivity due to the specimen geometry used. The added resistance (if any) of carbide precipitates was effective over only about 20 percent of the shear failure distance. Also evident in figure 5(c) are occasional carbides near the center of the button head. While this implies a greater diffusion rate in the longitudinal direction, as noted in an analogous system (ref.6), the lack of uniform diffusion in this case is not understood.

SUMMARY OF RESULTS

When tested in longitudinal (parallel to the alloy growth direction) shear, directionally solidified (DS) $\gamma/\gamma' - \delta$ eutectic alloys fail along the cell and grain bound-

aries. In an attempt to improve their longitudinal shear strength, carbide particles were selectively precipitated at the cell boundaries by using a carburization - carbide precipitation treatment. The following results were obtained from this study:

1. A preliminary pack-carburizing treatment (6 hr/1065^o C) plus solutioning (4 hr/1210^o C) plus aging (24 hr/870^o C) resulted in selective precipitation of rounded carbide particles to a depth of about 0.01 cm at the cell and grain boundaries of $\gamma/\gamma' - \delta$ eutectic alloys.

2. Niobium diffusion toward the carburizing surface resulted in a δ -denuded zone that varied from 0.011 cm for the alloy containing 1-wt% Mo to 0.001 cm for the alloy containing 3-wt% Ta. The Ni-17.8Nb-6Cr-2.5Al-3Ta alloy, which showed the shallowest δ -denuded zone, was selected for the shear strength evaluations because δ is the strengthening phase in $\gamma/\gamma' - \delta$ eutectic alloys.

3. To increase the depth of carbide precipitation to about 0.03 cm, a treatment consisting of carburization (20 hr/1093^o C) plus solutioning (24 hr/1210^o C) plus aging (24 hr/870^o C) was used for the 3-wt% Ta-containing $\gamma/\gamma' - \delta$ eutectic alloy. This carburization - carbide precipitation treatment did not appear to improve the longitudinal shear strength of the alloy at 760^o C. Separation along the cell and grain boundaries was the failure mode of the alloy containing the carbide precipitates as well as of the uncarburized materials.

Lewis Research Center.

National Aeronautics and Space Administration,
Cleveland, Ohio, December 14, 1976,
505-01.

REFERENCES

1. Jahnke, L. P.; and Bruch, C. A.: Requirements for and Characteristics Demanded of High Temperature Gas Turbine Components. AGARD Specialists Meeting on Directionally Solidified In-Situ Composites. AGARD-CP-156, E. R. Thompson and P. R. Sohm, eds., 1974, pp. 3-12.
2. Lemkey, F. D.: Eutectic Superalloys Strengthened by δ, Ni_3Cb Lamellae and γ', Ni_3Al Precipitates, NASA CR-2278, 1973.

3. Lemkey, F. D.; and McCarthy, G.: Quarternary and Quinary Modifications of Eutectic Superalloys Strengthened by $\delta, \text{Ni}_3\text{Cb}$ Lamellae and $\gamma', \text{Ni}_3\text{Al}$ Precipitates. (R911698-13, United Aircraft Corp.; NAS3-17785) NASA CR-134678, 1975.
4. Decker, R. F.; and Sims, C. T.: The Metallurgy of Nickel-Base Alloys. The Superalloys. C. T. Sims and W. C. Hagel, eds., John Wiley & Sons, Inc., 1972, pp. 33-77.
5. Sheffler, K. D.: Alloy and Structural Optimization of a Directionally Solidified Lamellar Eutectic Alloy. (PWA-5300, Pratt & Whitney Aircraft; NAS3-17811) NASA CR-135000, 1976.
6. Jackson, M. R.; Goldstein, J. I.; and Kraft, R. W.: Diffusion of Zinc in Lamellar Eutectic, Al-CuAl_2 . Metall. Trans., vol. 4, no. 9, Sept. 1973, pp. 2145-2151.

TABLE I. - LONGITUDINAL SHEAR STRENGTH OF DIRECTIONALLY SOLIDIFIED $\gamma/\gamma' - \delta$ EUTECTIC ALLOYS AT 760° C

Composition, wt%	Condition	Shear strength	
		MPa	ksi
Ni-20Nb-6Cr-2.5Al	As directionally solidified	287	41.6
		279	40.4
Ni-17.8Nb-6Cr-2.5Al-3Ta	Carburized	313	45.4
		323	46.8
		258	37.4

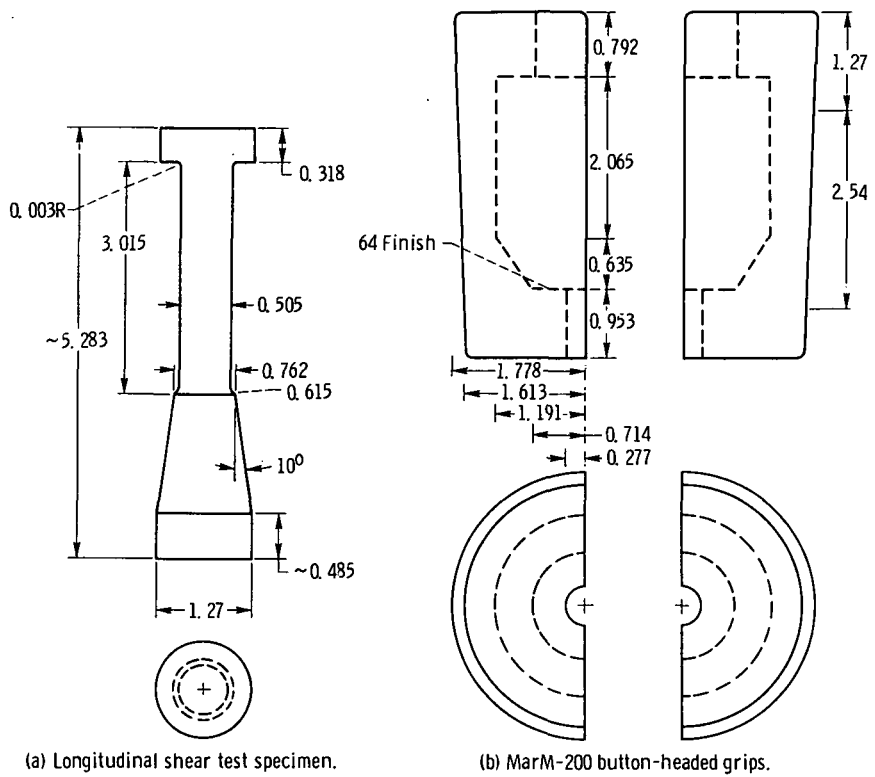

Figure 1. - Longitudinal shear test specimen and button-headed grips. (All dimensions are in cm.)

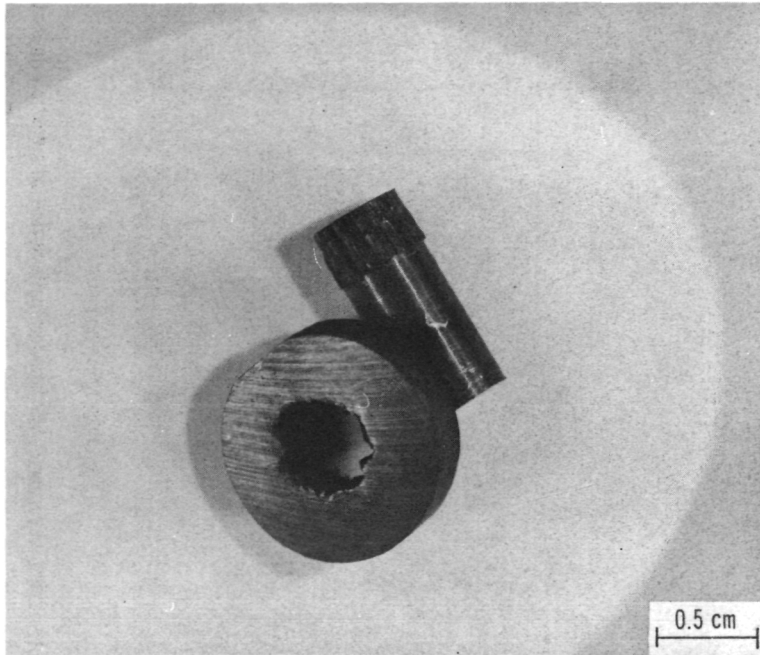
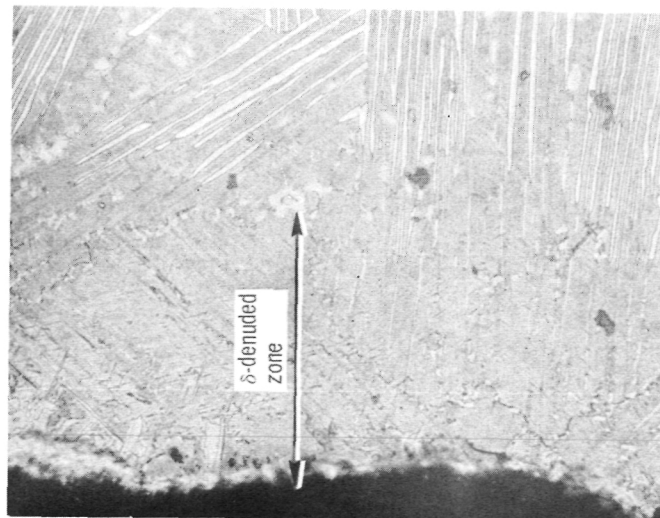
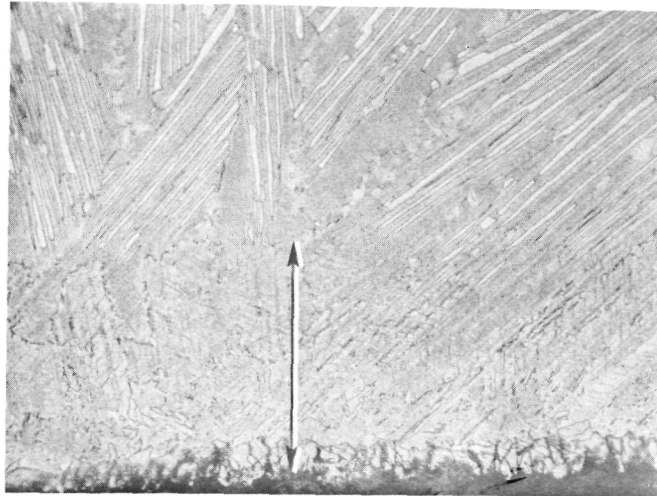

Figure 2. - Specimen failed in longitudinal shear. (Tapered end was cut off.)



(a) Ni-19.7Nb-6Cr-2.5Al-1Mo.



(b) Ni-20Nb-6Cr-2.5Al.

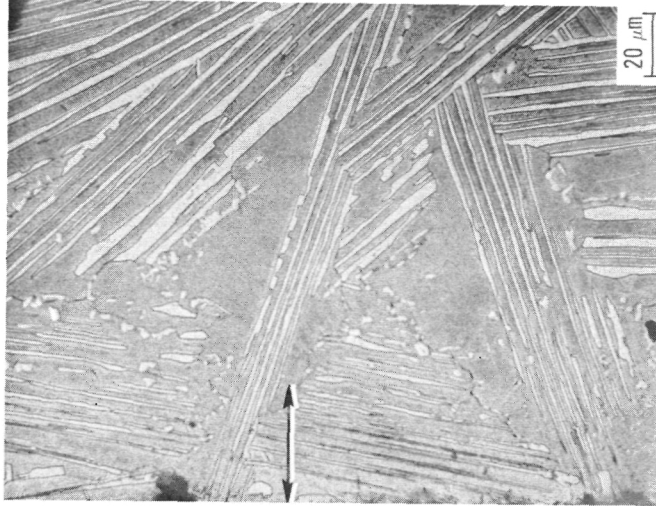

(c) Ni-18.6Nb-6Cr-2.5Al-0.87Ti.

Figure 3. - Effect of carburization and carbide precipitation treatment on various γ/γ' - δ directionally solidified eutectic alloys. Carburized (6 hr/1065° C) plus solutioned (4 hr/1210° C) plus aged (24 hr/870° C).

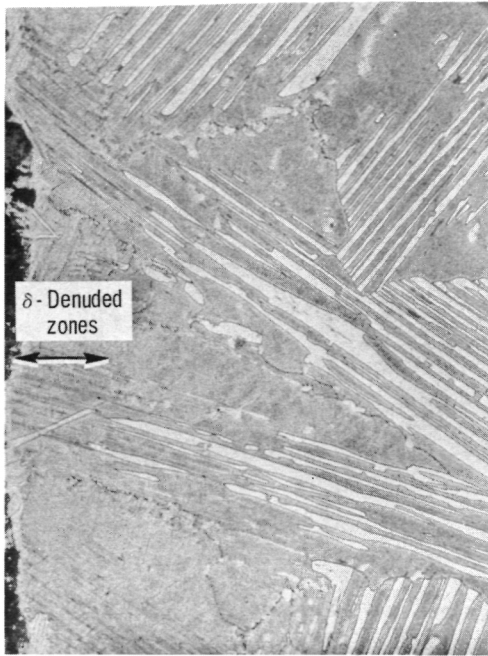

(d) Ni-19.7Nb-6Cr-2.5Al-1W.

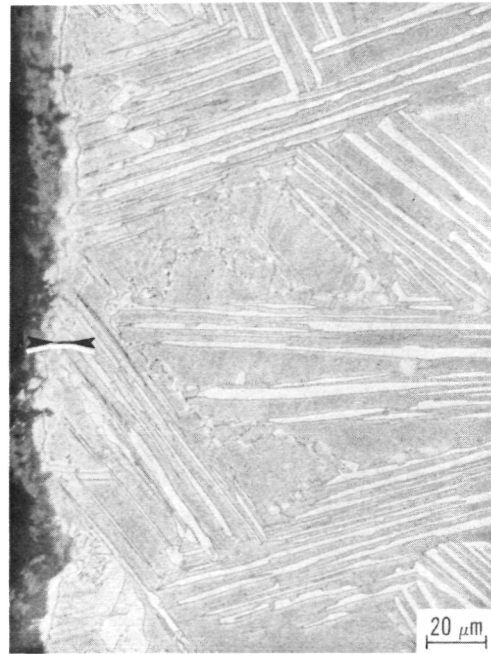

(e) Ni-17.8Nb-6Cr-2.5Al-3Ta.

Figure 3. - Concluded.

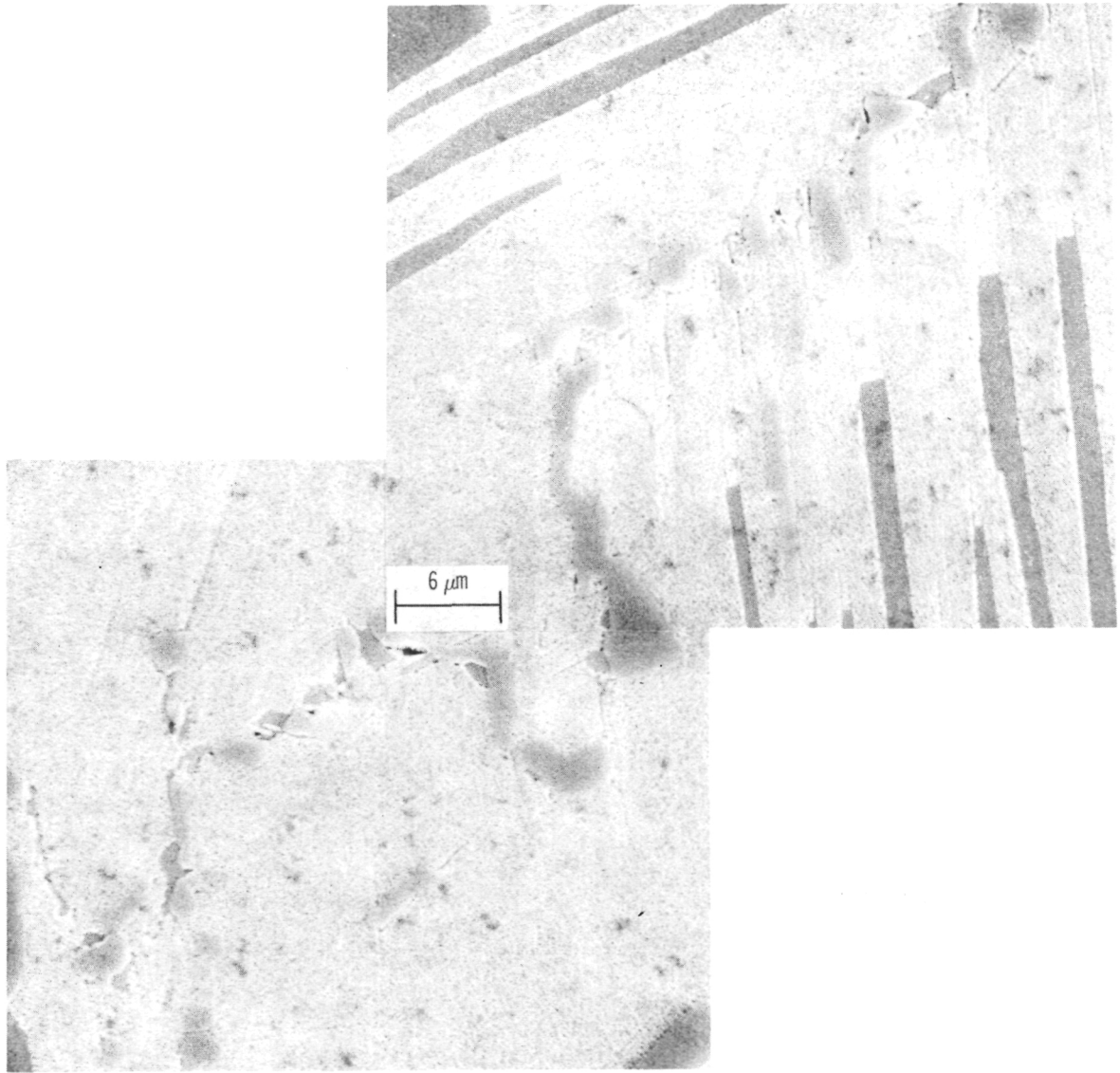

(a) Carbide precipitates at the cell boundary (SEM micrograph).

Figure 4. - Carbide precipitates at the cell boundary and an electron-microprobe line scan across them.

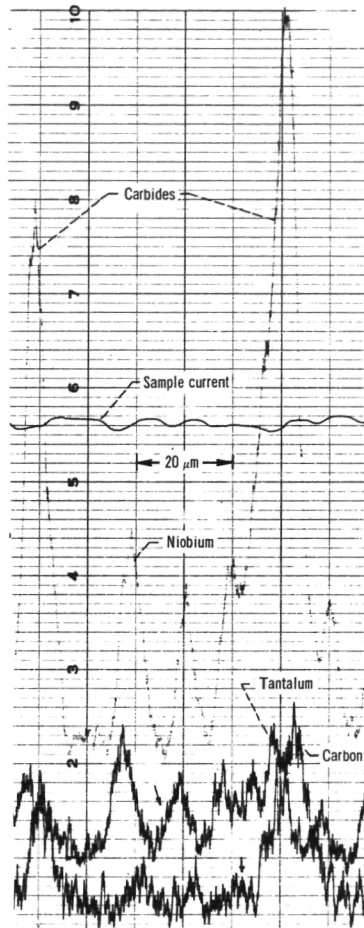

(b) Line traverse across carbide particles using electron microprobe.

Figure 4. - Concluded.

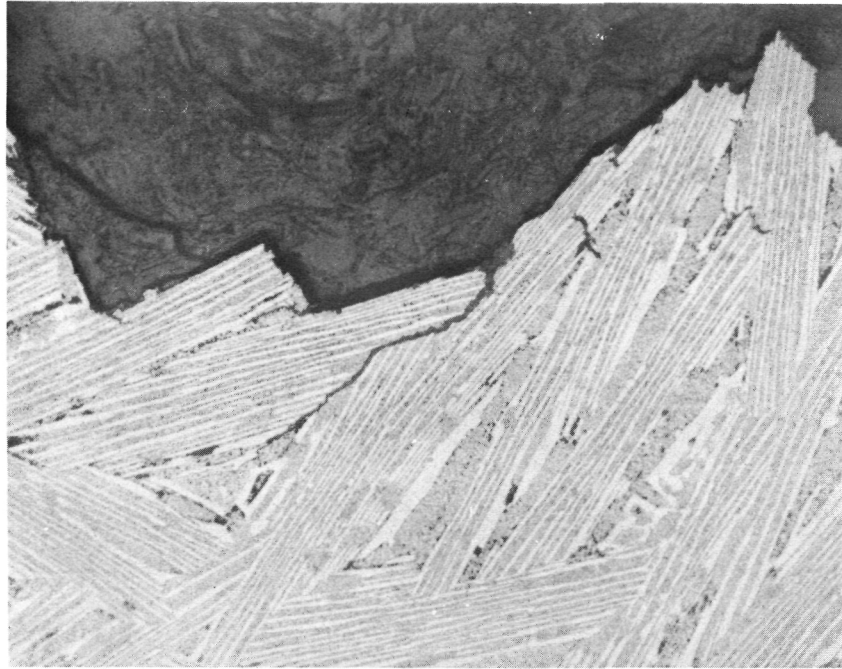

(a) As directionally solidified.

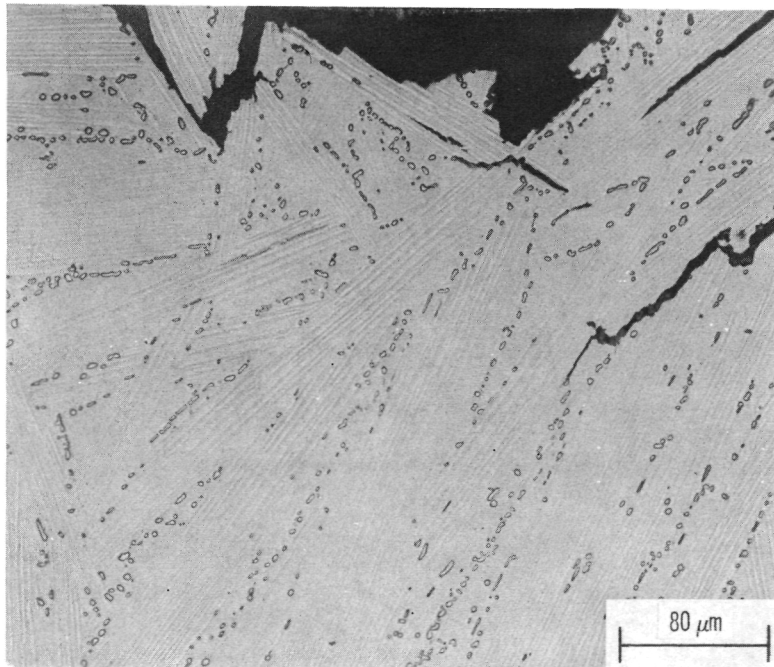

(b) Carburized (20 hr/1093° C) plus solutioned (24 hr/1210° C) plus aged (24 hr/871° C).

Figure 5. - Fracture profile of 3-wt% $\gamma/\gamma' - \delta$ directionally solidified eutectic alloy that failed in longitudinal shear.

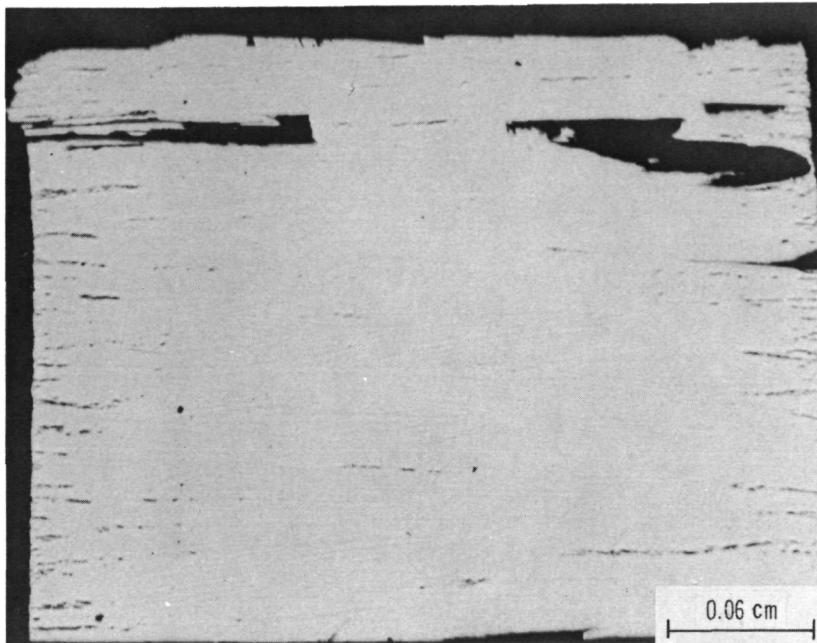

(c) Longitudinal section through carburized specimen button head that failed in shear.

Figure 5. - Concluded.



POSTMASTER : If Undeliverable (Section 158
Postal Manual) Do Not Return

"The aeronautical and space activities of the United States shall be conducted so as to contribute . . . to the expansion of human knowledge of phenomena in the atmosphere and space. The Administration shall provide for the widest practicable and appropriate dissemination of information concerning its activities and the results thereof."

—NATIONAL AERONAUTICS AND SPACE ACT OF 1958

NASA SCIENTIFIC AND TECHNICAL PUBLICATIONS

TECHNICAL REPORTS: Scientific and technical information considered important, complete, and a lasting contribution to existing knowledge.

TECHNICAL NOTES: Information less broad in scope but nevertheless of importance as a contribution to existing knowledge.

TECHNICAL MEMORANDUMS: Information receiving limited distribution because of preliminary data, security classification, or other reasons. Also includes conference proceedings with either limited or unlimited distribution.

CONTRACTOR REPORTS: Scientific and technical information generated under a NASA contract or grant and considered an important contribution to existing knowledge.

TECHNICAL TRANSLATIONS: Information published in a foreign language considered to merit NASA distribution in English.

SPECIAL PUBLICATIONS: Information derived from or of value to NASA activities. Publications include final reports of major projects, monographs, data compilations, handbooks, sourcebooks, and special bibliographies.

TECHNOLOGY UTILIZATION PUBLICATIONS: Information on technology used by NASA that may be of particular interest in commercial and other non-aerospace applications. Publications include Tech Briefs, Technology Utilization Reports and Technology Surveys.

Details on the availability of these publications may be obtained from:

SCIENTIFIC AND TECHNICAL INFORMATION OFFICE

NATIONAL AERONAUTICS AND SPACE ADMINISTRATION
Washington, D.C. 20546