

## General Disclaimer

### One or more of the Following Statements may affect this Document

- This document has been reproduced from the best copy furnished by the organizational source. It is being released in the interest of making available as much information as possible.
- This document may contain data, which exceeds the sheet parameters. It was furnished in this condition by the organizational source and is the best copy available.
- This document may contain tone-on-tone or color graphs, charts and/or pictures, which have been reproduced in black and white.
- This document is paginated as submitted by the original source.
- Portions of this document are not fully legible due to the historical nature of some of the material. However, it is the best reproduction available from the original submission.

**PERKIN-ELMER**  
AEROSPACE DIVISION

*CR 151342*

# SPACE SHUTTLE

## DEVELOPMENT OF A DRIVE SYSTEM FOR A SEQUENTIAL SPACE CAMERA

CONTRACT MODIFICATION 4(S)

### FINAL REPORT

(NASA-CR-151342) DEVELOPMENT OF A DRIVE  
SYSTEM FOR A SEQUENTIAL SPACE CAMERA  
CONTRACT MODIFICATION 4(S) Final Report  
(Perkin-Elmer Corp.) 26 p HC A03/MF A01

N77-23438

CSCL 14E G3/35      Unclass 26144

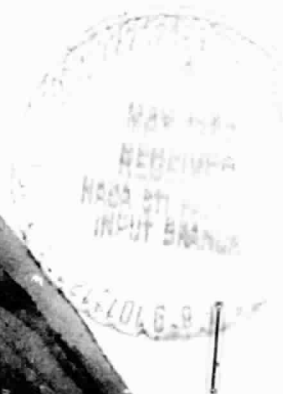

THE PERKIN-ELMER CORPORATION  
AEROSPACE DIVIION  
2771 North Garey Avenue, Pomona, California 91767

FINAL REPORT  
FOR  
DEVELOPMENT OF A DRIVE SYSTEM  
FOR A SEQUENTIAL SPACE CAMERA  
CONTRACT MODIFICATION 4(S)

BY

James T. Sharpsteen, Duard L. Lund,  
Curtis D. Solheim, Louis J. Stoap

April 1977

Perkin-Elmer SPO 30352  
NASA Contract Number NAS9-14573

Prepared for  
NATIONAL AERONAUTICS AND SPACE ADMINISTRATION  
Johnson Space Center  
Houston, Texas 77058

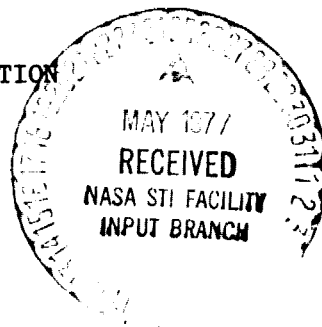

## TABLE OF CONTENTS

	<u>Page</u>
1. INTRODUCTION	1
2. OBJECTIVE OF MODIFICATION 4(S)	2
3. APPROACH	2
4. TEST HARDWARE	3
4.1 Mechanical	3
4.2 Electronics	9
4.3 Operation	14
5. TEST PROGRAM	14
5.1 General	14
5.2 Test Parameters	16
5.3 Test Procedure	16
5.4 Test Results	19
6. SUMMARY AND CONCLUSIONS	21

## LIST OF ILLUSTRATIONS

<u>Figure</u>		<u>Page</u>
4-1	Modified Breadboard Motor and Gearing Installation	4
4-2	Optical Wheel	5
4-3	Brassboard Motor and Gearing Installation	7
4-4	Shutter Control Knob Compensation Mechanism	8
4-5	Brassboard Motor Drive and Control Electronics	11
4-6	Brassboard Motor Drive Electronics Schematic	12
5-1	LED/Sensor Shutter Speed Test Circuit	17
5-2	Input current Test Circuit	17
5-3	Optical Configuration for the Shutter Position Detector	18

## 1. INTRODUCTION

The final report for the development of a drive system for a sequential space camera, under NASA Contract Number NAS9-14573, was submitted by the Perkin-Elmer Corporation Aerospace Division, Pomona, California in March 1976, and an addendum covering final testing after this date was submitted in May 1976. Subsequently, a change order was received adding additional work, designated Modification 4(S) to the contract. This report summarizes that work, and the results. To avoid duplication, this report covers only the last amendment, and should be used in conjunction with the final report and the addendum to gain a full perspective of the work that was accomplished.

The statement of work for Modification 4(S) consists of two parts, (1) development of a camera brassboard using the single motor drive system, and (2) the development of a multipurpose programmable timer/intervalometer (MPTI) designed to interface with the brassboard. This report covers the camera drive system only. The MPTI is fully covered in the design review report submitted in November 1976.

The following terminology identifies the experimental hardware that was developed in the camera drive system study:

- a. Breadboard. This identifies the state of the test hardware at the time of the final report and the addendum. It is fully described in the final report.
- b. Modified Breadboard. This identifies the breadboard as modified for use in Modification 4(S).
- c. Brassboard. This is the term used for the final hardware developed under the study. Like the breadboard, it uses a DAC body and mechanism, except for the clutch. All mechanical and electronic parts are packaged within the DAC body.

The final report and addendum clearly show that the single electronically commutated motor drive method offers the greatest promise for further development, based on simplicity and availability of hardware.

The results of Modification 4(S) as summarized in this report, fully justify the selection of this approach.

## 2. OBJECTIVE OF MODIFICATION 4(S)

The objective of Modification 4(S) is to continue the development of the single motor electronically commutated motor drive approach, and to construct a brassboard where both the mechanical and electronic components are packaged within the DAC camera body. The final step is to evaluate the performance of the brassboard.

Independence of frame rate and shutter speed settings has been essentially achieved, although this was not a requirement for the camera brassboard.

Time exposure, likewise not a requirement, is also provided in the brassboard. Thus, the brassboard offers all modes of operation available in the standard DAC.

## 3. APPROACH

The motor drive approach used in the brassboard employs a single electronically commutated dc motor to drive all functions without resorting to a solenoid actuated clutch for pulse operation. Shutter and claw speeds for 24 and 12 frames per second (fps) are established by regulating the motor speed while operating in the cine mode. The six and two fps modes are obtained by pulsing the motor at the appropriate rates, with an instantaneous speed equivalent to a 12 fps cine mode speed. The power to the motor is applied at a fixed clock rate, and removed at the appropriate point in the mechanical cycle such that the motor comes to rest with the shutter in the closed position.

Through this approach, nonindependence of shutter speed and frame rate has been minimized, because only a one stop shift in exposure time occurs when the frame rate is changed from 24 fps to any of the lower available frame rates, and vice versa. Thus, the range of shutter speeds available in the brassboard are 1/60 second to 1/1000 second for 24 fps operation (same as the DAC) and 1/30 second to 1/500 second for 12, 6 and 2 fps. In most cases, a one stop shift will have essentially no effect on the photographic results. However, in situations where it is necessary, the shutter speed (opening) is easily adjusted manually by one stop to compensate for this change, or in the case of a camera with Automatic Exposure Iris Control (AEIC) developed by Perkin-Elmer under NASA Contract NAS9-12790, automatic compensation of iris opening with change in frame rate could be easily incorporated in the Automatic Exposure Control (AEC) in the same manner that shutter speed compensation is provided. To assist in making the manual adjustment in the brassboard a mechanism was incorporated which indicates to the camera operator what change in shutter speed (if any) has occurred when a change in frame rate has been made. If desired, the operator can then turn the shutter control knob one notch to bring the exposure back to the original setting. Details of the mechanism are covered in Section 4.1.2 of this addendum.

Two fundamentally different methods are available for controlling electronic commutation of the motor. These are: (1) optical commutation, and (2) Hall effect devices which sense magnetic field changes in the motor. Although the motor selected has built-in Hall effect devices for commutation, it was decided to adapt the motors for optical commutation because of advantages presented in Section 4.2 of this addendum.

There are also two methods available for motor speed control, (1) series regulation, and (2) Pulse Width Modulation (PWM). The electronic commutation circuit offered by the motor manufacturer uses series regulation, however, pulse width modulation offers the best system efficiency and smaller size. Because of the stringent requirements for small size and power consumption, PWM was selected for the brassboard. For the detailed description see Section 4.2.

#### 4. TEST HARDWARE

##### 4.1 MECHANICAL

4.1.1 MODIFIED BREADBOARD. Although not required by Modification 4(S), it was decided to modify the breadboard described in the final report in order to perform preliminary tests on the new electronically commutated motor and the new electronic circuit designs, before committing them to the brassboard. The motor is wound for 28.8 gram/centimeters (0.40 ounce/inch) torque and 8,000 rpm at 18 to 20 volts input. The motor frame fits within the allowable thickness of the DAC.

Figure 4-1 shows the installation of the motor in the modified breadboard. The pinion on the motor was changed to give an overall gear ratio of 5 to 1, instead of 4 to 1 as used with the larger motor in the original breadboard. Initial tests used the motor with Hall effect commutation, as delivered. These tests established that the motor performance was within specification.

Optical commutation was next tested by adding a simple encoder, also shown in Figure 4-1, for commutation control. It consists of two commercially available optical switches, mounted 90° apart about the axis of the motor. Each optical switch consists of an LED and a photodarlington, on opposite sides of the gap. An optical wheel, similar to the center portion of that shown in Figure 4-2, is attached to the end of the motor pinion and runs in the switch gaps. The output of the optical commutator is a 2 bit Gray code (reflected binary) which changes one bit only for every 90° of rotation. The Gray code was selected because only one bit changes at a time, so that there is never an uncertainty in output. The output of the encoder is decoded by an electronic circuit and used to control the power to the motor windings.

A continuous string of pulses with rate proportional to motor speed was obtained by applying 32 radial black stripes to the face of the intermediate gear, and detecting these stripes with a reflective type optical sensor, as shown in Figure 4-1. These pulses were used by the PWM circuit to regulate motor speed.



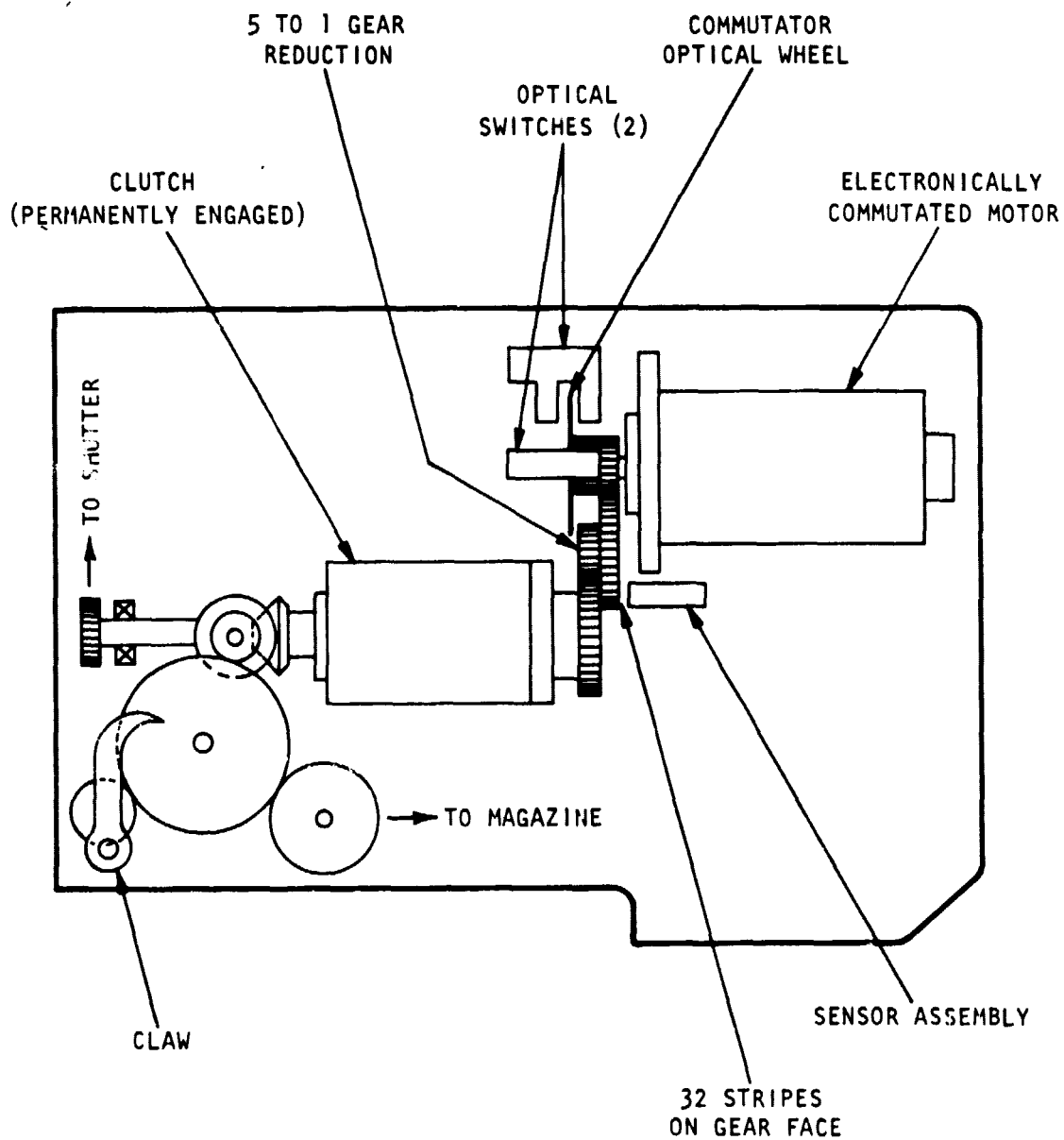
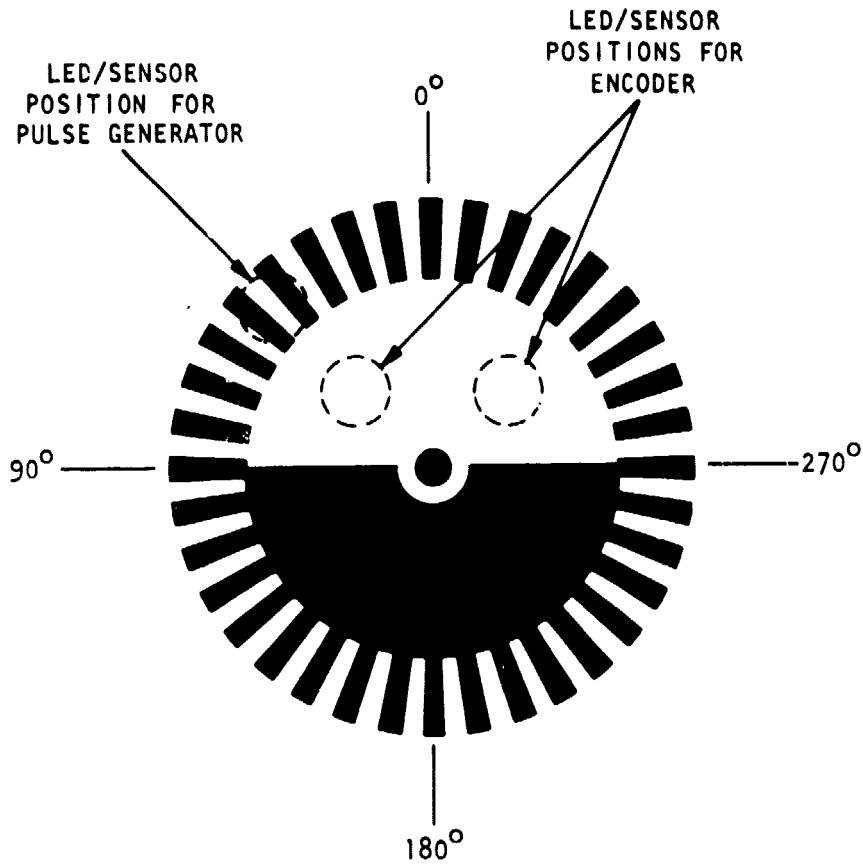

FIGURE 4-1. Modified Breadboard Motor and Gearing Installation



ENCODER OUTPUT

ANGLE	CODE	
0°	0	0
90°	0	1
180°	1	1
270°	1	0

0 = NO LIGHT INTERRUPTION  
 1 = LIGHT INTERRUPTION

FIGURE 4-2. Optical Wheel

Using the modified breadboard, all circuit concepts were successfully tested, except for camera pulse mode operation. It was not felt necessary to test this in the modified breadboard, because the concept had been tested successfully in the original breadboard.

4.1.2 BRASSBOARD. The layout for the mechanical installation in the brassboard is shown in Figure 4-3. The main difference from the modified breadboard is that a special 5.5 to 1 gear head was installed directly on the motor to provide a more size efficient package, and to eliminate the inertia of the permanently engaged clutch used in the modified breadboard. The compact size of this arrangement provides more space for packaging of the motor drive electronics.

The motor/gear head is supported on its shaft at the forward end by a bearing from the DAC, and is supported at the rear by a printed wiring board which is soldered to the motor terminal pins, which also serve to bring power to the motor. Although this method of mounting is not recommended for a final camera design, it had the advantage here of providing an economical way to mount the motor/gear head assembly, which is not provided with other means for mounting. Since the mounting points are at the extreme ends of the assembly, alignment is not critical.

An optical encoder and pulse generator was added to the rear of the motor, as shown in Figure 4-3. The optical wheel is shown in Figure 4-2. The center portion provides the Gray code for commutation, the same as in the modified breadboard, while the outer track provides the pulses for speed control. The energy sources for the commutator and the pulse generator are infrared light emitting diodes, while the detectors are phototransistors.

Two once per frame position indicators for controlling motor braking are located at the forward end of the motor/gear head, between the gear head and the bevel gear, as shown. Each consists of an infrared LED and a photodarlington in a reflective configuration, detecting black segments on a sleeve over the shaft. Both the sleeve and the devices can be rotated in relation to the shaft to put the outputs in proper phase relations with the shutter. One output is used to stop the shutter in the open position for time exposure, while the other stops the shutter in the closed position for time exposure and pulsemodes (6 and 2 fps).

As explained in Section 3, the one stop change in exposure which occurs when changing from 24 fps to any of the other frame rates (12, 6, and 2 fps) will not normally cause a loss in photographic quality. However, it is highly desirable that the shutter control knob on the camera always indicate the actual shutter speed. Figure 4-4 shows how this was accomplished in the brassboard.

The DAC shutter speed control knob was remachined to eliminate the engravings, and a single index mark was added. A stationary plate was added to the camera as shown, with engraved lines for each shutter speed, arranged logarithmically

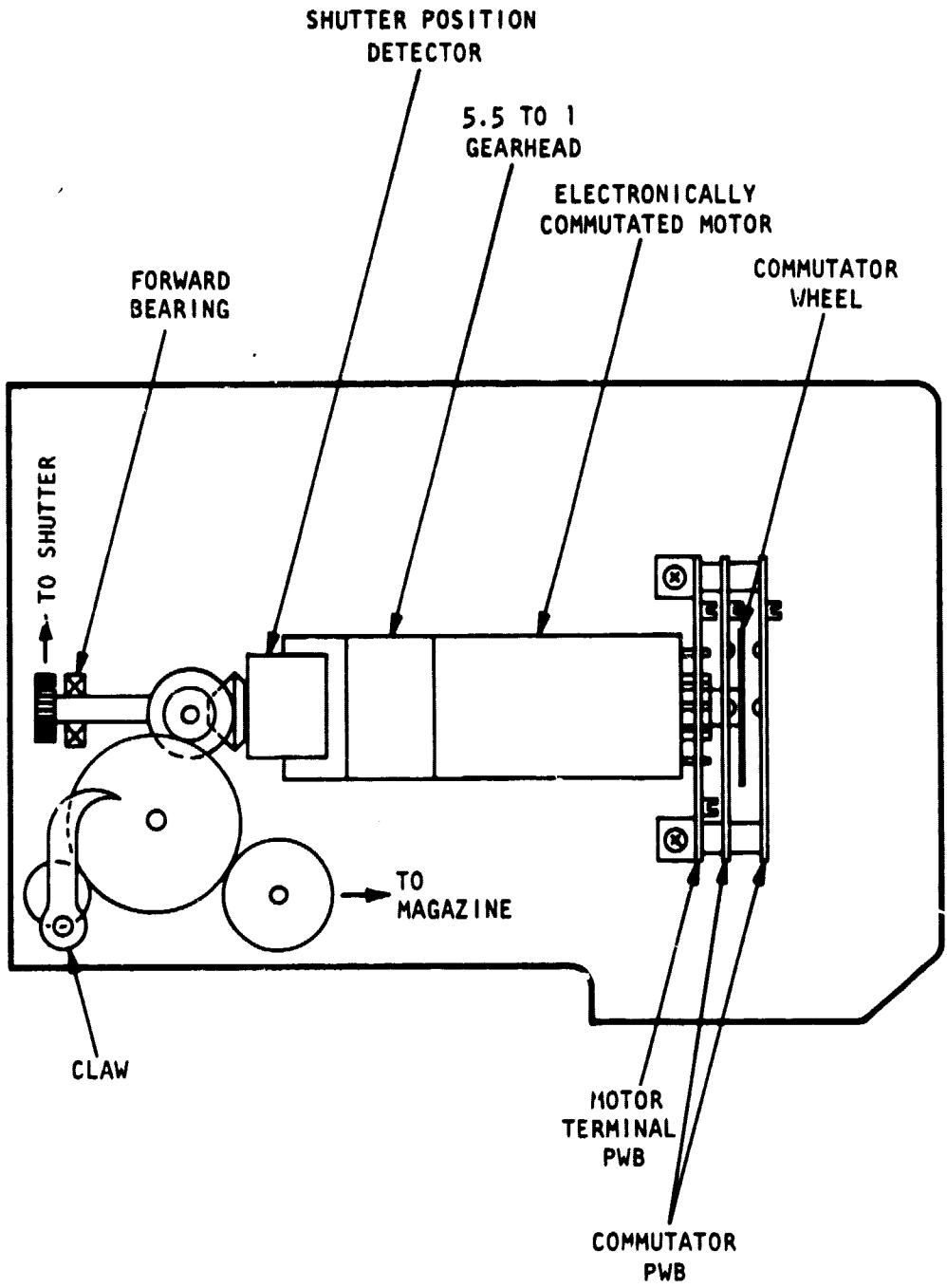

FIGURE 4-3. Brassboard Motor and Gearing Installation

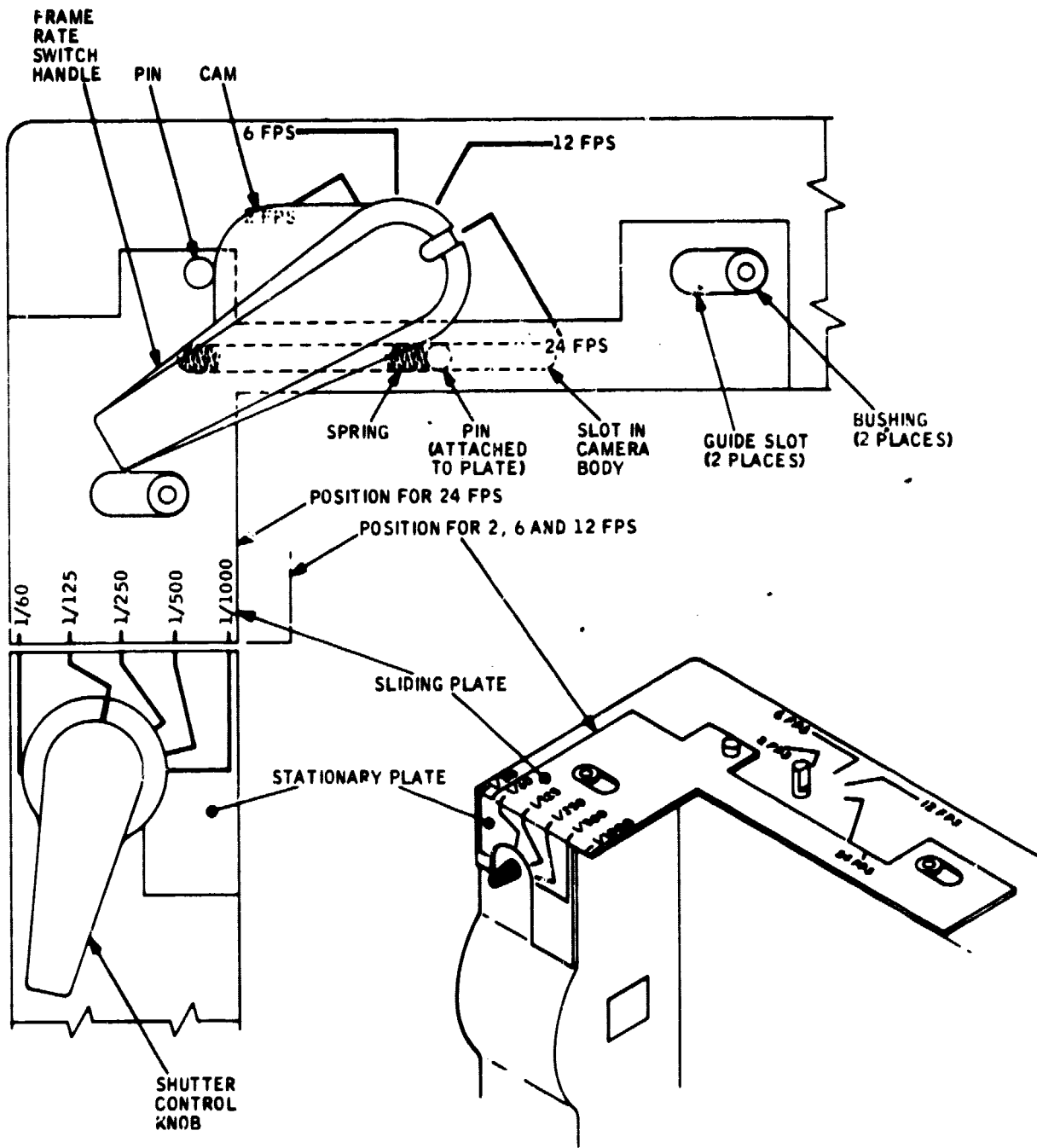

FIGURE 4-4. Shutter Control Knob Compensation Mechanism

in agreement with the knob position for each shutter opening. These lines continue to the top of the plate where they become equally spaced. A second plate with matching lines slides along the top of the camera. Each line on the movable plate is identified with the appropriate shutter speed.

A cam was added to the frame rate switch, which pushes against a pin attached to the movable plate. Slots in the plate guide it in the direction of the camera axis.

A spring in a groove cut in the camera body, underneath the movable plate, pushes against a second pin in the plate, thus keeping the first pin always against the cam. The relation of the cam to the cam pin is such that the plate is fully forward for the 24 fps setting and 1 stop back for 12, 6 and 2 fps. In addition, when in the back position the plate uncovers an engraved 1/30 second mark at the position previously identified on the movable plate as 1/60 second. Thus, the shutter speed scale is shifted down one stop when frame rate is changed from 24 fps to any of the other frame rates, and the shutter speed knob always shows the correct shutter speed, regardless of the frame rate setting.

Of course, if AEC is incorporated in the camera the change in shutter speed will be automatically compensated by a change in iris setting, and concern for shutter speed might therefore be unnecessary.

## 4.2 ELECTRONICS

4.2.1 MODIFIED BREADBOARD. In order to minimize package size and power consumption, it was necessary to design a speed control circuit which would allow the use of smaller drive transistors than are normally used in motor control circuits. Reduced transistor power dissipation was accomplished by pulse width modulating each drive transistor while commutating the motor windings. That is, during the commutation cycle when a drive transistor is normally on, it is pulse width modulated between OFF and fully ON instead of being operated in the linear (active) region. The ratio of the transistor ON to OFF time establishes an average voltage applied to the motor and determines motor speed. Operating the transistors in either a fully ON state or fully OFF state reduces transistor power dissipation by eliminating the condition when the transistors must supply current and drop voltage simultaneously.

All of the electronically commutated motors purchased for the study contain Hall effect devices for sensing rotor position. The first breadboard speed control circuit used these for controlling commutation, and regulated the motor back EMF for speed control by using pulse width modulation. The Hall effect device outputs are low amplitude sinusoidal signals. Each signal amplitude varies dramatically with temperature and from generator to generator. This makes precise commutation control very difficult and requires excessive circuitry. Therefore, an optical rotor position encoder was substituted for the Hall devices on the modified breadboard and the brassboard. An optical tachometer was also incorporated in the rotor position encoder and substituted for back EMF sensing to improve motor speed regulation and transient response of the control loop.

In order to operate the camera in the pulse mode with a base speed greater than 6 fps, the motor must be capable of starting and stopping rapidly. Starting the motor is a function of the applied voltage at turn-on. Using pulse width modulation for speed control allows the full line voltage to be applied to the motor during start-up, therefore optimizing start-up conditions.

To stop the motor rapidly, a brake must be employed. Two methods of electronic braking were investigated. The first method consisted of removing motor drive and shorting the motor windings. This method was relatively effective at high motor speeds but became less effective as the motor slowed down and coasted to a stop, and therefore, this method of braking is not adequate for pulse mode operation. The second braking method sequences the motor drive transistors in the reverse direction of motor rotation, as though trying to reverse the motor. When the speed reaches zero, power is removed to prevent the motor from running backwards. This braking method is very effective and is used on the brassboard.

4.2.2 BRASSBOARD. A functional block diagram of the brassboard electronically commutated motor drive and control electronics is shown in Figure 4-5, and a schematic is shown in Figure 4-6. The block diagram can be divided into four main functional sections; the motor commutation section, the motor speed control section, the local/remote control section, and the regulator section.

The motor commutation section includes the rotor position encoder, the run/brake control, the motor drive switches, and the shutter position encoder. The rotor position encoder utilizes two LED, two phototransistors, and an encoder wheel to generate a two bit Gray code which defines one of four quadrature area positions of the rotor. The rotor position information is decoded within the run/brake control where it is used for commutating and braking the motor via the motor drive switches. Motor commutation is initiated with either a local trigger command or a remote trigger command and will continue for the duration of the command.

When the trigger command is removed, the motor will continue to run until the shutter closes. The closed shutter position is detected by the shutter position encoder where a shutter closed pulse is generated. This pulse initiates a motor brake command in the run/brake control. The brake command reverses the motor commutation sequence, thus reversing the motor drive direction. When the motor speed reaches zero, the brake command is inhibited and all motor drive is removed.

The motor speed control section includes the rotor velocity encoder, the frequency/voltage converter, and the pulse width modulator. The speed of the motor is optically detected by the rotor velocity encoder and converted into a squarewave. The frequency is proportional to motor speed. The squarewave is then converted into a voltage proportional to frequency within the frequency/voltage converter.

This voltage representation of motor speed is compared with a reference voltage within the pulse width modulator to generate an error signal. The error signal is used to control the pulse width of the output pulse train which then modulates the motor commutation signals developed in the run/brake control. The

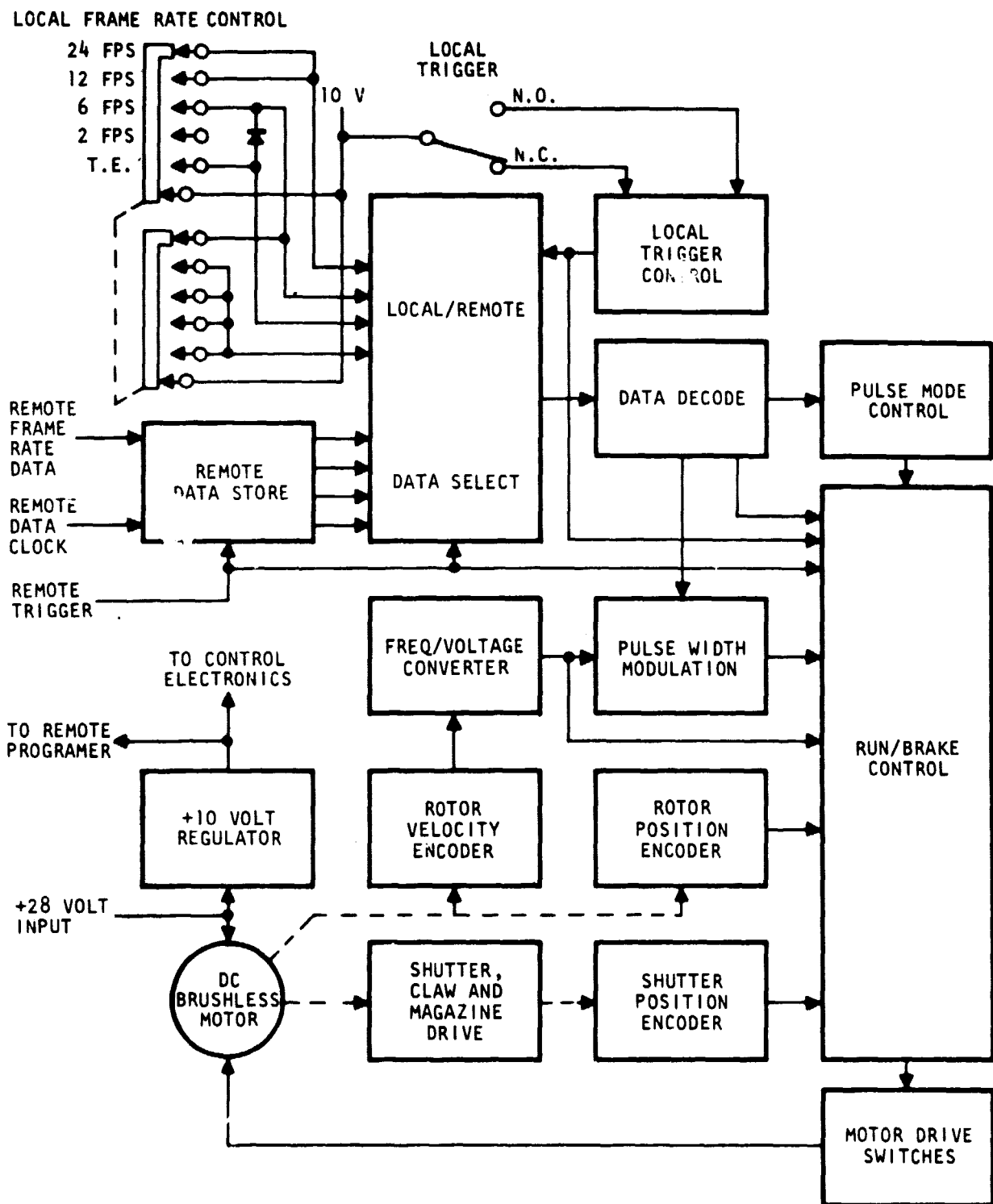

77-043

FIGURE 4-5. Brassboard Motor Drive and Control Electronics



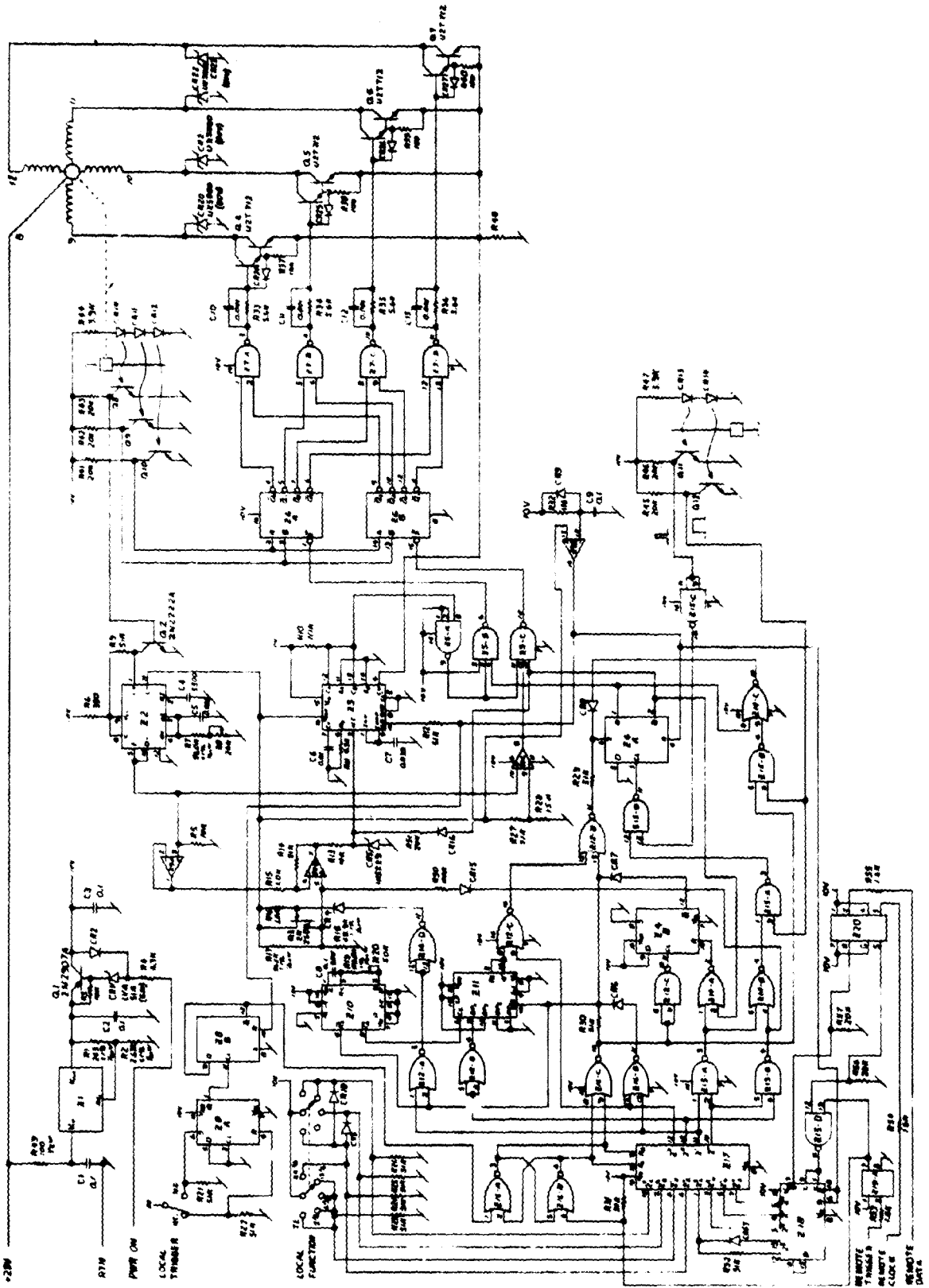

FIGURE 4-6. Brassboard Motor Drive Electronics Schematic

ORIGINAL PAGE IS  
OF POOR QUALITY

motor speed control loop is phased so that if a motor overspeed condition is sensed, the pulse width of the modulating pulse train is reduced which causes a reduction in motor speed. If a motor underspeed condition is sensed, the pulse width is increased causing an increase in motor speed.

The local/remote control section includes the local trigger control, the local frame rate control switch, the remote data store, the local/remote data select, the data decode, and the pulse mode control. The local trigger control contains a switch debounce circuit and a flip flop. It accepts the signal from the local trigger momentary push button switch and debounces the signal in order to toggle the flip flop only once for each actuation of the switch. The output of the flip flop is the local trigger command signal. The local frame rate control switch is connected in such a manner that a unique four bit data code is generated for each of the five switch positions. The five frame rate switch selections are: 24 fps cinemode, 12 fps cinemode, 6 fps pulse mode, 2 fps pulse mode, and time exposure. The selected frame rate code is continually present in parallel form at the local frame change rate data input for the local/remote data select block.

The remote data store contains a shift register for converting remote frame rate data from serial to parallel form. The shift register also functions as a memory by inhibiting the remote data clock signal after the data has been shifted into the register. The remote data is held in the register and is present in parallel form at the remote frame rate data input of the local/remote data select whenever a remote trigger command signal is present on the remote trigger line. Besides the five frame rate codes used for local programming, one additional code is used for remote pulse mode operation. This additional code allows the Multipurpose Programmable Timer/Intervalometer (MPTI) to operate the camera in a pulse mode for any frame rate of 5 fps or less.

The local/remote data select selects either the local frame rate data or the remote frame rate data for frame rate control. The local frame rate data is selected with the local trigger command signal and the remote frame rate data with the remote trigger command signal. The first trigger command signal to be activated inhibits the other trigger command signal thereby preventing frame rate data and trigger command interaction in the event the camera receives both trigger command signals simultaneously. The selected frame rate data is available at the local/remote data select output coincident with the respective trigger command signal.

The data decode receives the selected frame rate data, decodes the data and generates the required control signals to comply with the frame rate data command. These control signals include motor speed selection, frame rate selection, and cinemode, pulse mode, or time exposure selection.

The pulse mode control contains the intervalometer for pulse mode operation at 6 fps and 2 fps. It controls the frame rate when one of these two frame rates are programmed either locally or remotely. When cinemode operation, time exposure, or external pulse mode operation is programmed, the pulse mode control block is bypassed.

The regulator section includes a voltage programmable series pass integrated circuit voltage regulator, programming resistors, and filter capacitors. It drops the varying input line voltage to a stable 10 volts to operate all the motor control circuitry. Provisions can also be provided for switching the 10 volts on and off externally and supplying 10 volt power to the Multipurpose Programmable Timer/Intervalometer (MPTI). This latter provision would allow the MPTI to be operated from the camera power source, thus eliminating the battery drain on the MPTI internal battery.

#### 4.3 OPERATION

The brassboard can be programmed and operated either locally, or remotely with the MPTI. Local programming is accomplished with the local frame rate switch on the camera. The 24 fps and 12 fps switch positions program the camera to operate cine mode at the respective frame rates. The 6 fps and 2 fps switch positions program the camera to operate pulse mode at the respective frame rate and with a base shutter speed of 12 fps. The TE switch position programs the camera to operate in the time exposure mode allowing the operator to control the time the shutter is open.

Once the camera is programmed, camera operation is initiated by pressing the local trigger switch one time. When programmed for cinemode or pulse mode operation, the camera will operate until the trigger switch is pressed the second time. When programmed for time exposure, the shutter opens with the first switch actuation and closes for the second switch actuation.

Remote programming and operation is accomplished with the Multipurpose Programmable Timer/Intervalometer (MPTI). The MPTI gives the operator the capability of programming the mode of operation (24 fps cinemode, 12 fps cinemode, 6 fps pulse mode, 2 fps pulse mode, time exposure, and remote pulse mode) start delay time, run time, rerun time, and stop time. While operating in the time exposure mode, the run time and rerun time parameters are used to program exposure time and time between exposures respectively. While operating in the remote pulse mode, the run time parameter is used to initiate a single frame exposure while the rerun time parameter is used to program frame rate. For more detailed MPTI programming instructions, refer to Table 1, MPTI Program Operating Modes, under Intervalometer mode.

### 5. TEST PROGRAM

#### 5.1 GENERAL

The first electronically commutated motor drive breadboard using the Single Motor Approach was tested and the results documented in the Addendum to Final Report, Development of a Drive System for a Sequential Space Camera dated May 1976. The electronically commutated motor drive brassboard was tested using the same test setups and procedures used for the breadboard tests and the results documented in Paragraph 5.4 of this report. For convenience, the applicable breadboard test parameters, setups, and procedures are repeated here. Except where noted, all tests were made using a loaded Model 308MA film magazine.

TABLE 1. MPTI Program Operating Modes

MODE	PARAMETER				STOP	START	STOP	DISPLAY	OUTPUT	AUDIO	APPLICATIONS
	DELAY	RUN	R. RUN	FRAME RATE							
STOPWATCH	X	X	X	X	SW or EXT	SW or EXT	EXT EXT ET HELD	--	--	--	1. Stopwatch 2. Record Elapsed Time Between External Events
	P	P	P	X	SW or EXT	SW or EXT	EXT EXT ET HELD	OFF (Delay) ON (Run) OFF (R.Run)	OFF (Delay) ON (Run) OFF (R.Run)	OFF (Delay) ON (Run) OFF (R.Run)	1. Delayed Event Timer 2. Alarm Clock with Repeated Alarm
	X	P	P	X	SW or EXT	SW or EXT	EXT ET HELD	--	--	OW (Run) OFF (R.Run)	Event Timer - No Delay
EVENT TIMER	P	P	P	X	SW or EXT	SW or EXT	EXT EXT ET HELD	OFF (Delay) ON (Run)	OFF (Delay) ON (Run)	OFF (Delay) ON (Run)	Alarm Clock with Single Alarm
	P (opt.)	P	P	X	SW or EXT	SW or EXT	EXT EXT ET HELD	OFF (Delay) ON (Run) OFF (R.Run)	End of (Delay) ON (Run) End of (Stop)	End of (Delay) ON (Run) End of (Stop)	1. 16mm Camera Controller - Repeated ON/OFF Cycles at Frame Rate Set At Camera. 2. Still Camera Controller - Repeated Pictures.
	P (opt.)	P	P	X	SW or EXT	SW or EXT	EXT EXT ET HELD	OFF (Delay) ON (Run) OFF (R.Run)	End of (Delay) ON (Run) End of (Stop)	End of (Delay) ON (Run) End of (Stop)	1. 16mm Camera Controller - Single ON Cycle at Frame Rate Set at Camera. 2. Still Camera Controller - One Picture only; can be Delayed if DELAY is Programmed.
INTERVALOMETER	P (opt.)	P	P	X	SW or EXT	SW or EXT	EXT EXT ET HELD	OFF (Delay) ON (Run) OFF (R.Run) P. Rate	End of (Delay) ON (Run) End of (Stop)	End of (Delay) ON (Run) End of (Stop)	16mm Camera Controller - Repeated ON/OFF Cycles at Frame Rate Programmed.
	P (opt.)	P	P	X	SW or EXT	SW or EXT	EXT EXT ET HELD	OFF (Delay) ON (Run) OFF (R.Run) P. Rate	End of (Delay) ON (Run) End of (Stop)	End of (Delay) ON (Run) End of (Stop)	16mm Camera Controller - Single ON Cycle at Frame Rate Programmed. If Time Expiration or External Pulse Mode is Programmed, only one Picture will be Taken.
	P (opt.)	P	P	X	SW or EXT	SW or EXT	EXT EXT ET HELD	OFF (Delay) ON (Run) OFF (R.Run) P. Rate	End of (Delay) ON (Run) End of (Stop)	End of (Delay) ON (Run) End of (Stop)	16mm Camera Controller - Single ON Cycle at Frame Rate Programmed. If Time Expiration or External Pulse Mode is Programmed, only one Picture will be Taken.

\* P (STOP) may be overridden by stop switch  
 \*\* Information in memory may be displayed by selecting parameter desired

Z = No Program Entry  
 P = Program Entry

SW = Switch  
 EXT = External Signal  
 R. RUN = Repeat Run

EDT = Elapsed Delay Time  
 ERT = Elapsed Running Time  
 ET = Elapsed Time

## 5.2 TEST PARAMETERS

Performance parameters which will most likely be influenced by a commutated motor drive scheme were selected for measurement. These parameters are listed below:

- a. Shutter Speed - Frame to frame
- b. Shutter Speed - Across the frame (banding effect)
- c. Maximum Frame Rate - Pulse mode
- d. Maximum Frame Rate - Cinemode
- e. Start-up Time - (Number of frames required)
- f. Current - Start-up (peak); Running (Peak and average)

5.2.1 TEST CONFIGURATION. The test circuits for measuring the parameters listed in Paragraph 5.2 are shown in Figures 5-1 and 5-2. The physical relationship between the shutter, aperture, and LED/Sensor assembly used to measure shutter speed and frame rate are shown in Figure 5-3.

5.2.2 TEST CONDITIONS. All testing was accomplished under room ambient temperature and humidity conditions. The tests were performed at three different input voltages to demonstrate the effectiveness of pulse width modulation speed control under varying input voltage conditions.

## 5.3 TEST PROCEDURE

5.3.1 SHUTTER SPEED (FRAME TO FRAME). The LED/Sensor configuration shown in Figure 5-3 was directed at a point just inside the right edge of the aperture. During the time the shutter covers this point, light is reflected to the sensor and a dc level of approximately +9 V dc appears at the output. When the shutter opening uncovers this point, the LED emits into a void and the light is not reflected back to the sensor. This causes the output signal to return to ground. The time duration of the ground level thus becomes a measurement of the shutter speed.

5.3.2 SHUTTER SPEED ACROSS THE FRAME (BANDING EFFECT). To insure that a banding effect (uneven exposure across one frame) does not exist, the above described procedure was repeated with the LED/Sensor directed at the center and left edge of the aperture respectively.

5.3.3 MAXIMUM FRAME RATE (PULSE MODE). The maximum frame rate in pulse mode operation was determined by setting the cinemode base speed at 12 fps and then increasing the pulse mode clock rate until unreliable operation was observed.

5.3.4 MAXIMUM FRAME RATE (CINEMODE). The maximum frame rate in cinemode operation was determined by disabling the pulse width modulation circuit and increasing the input voltage to the motor to 20 V dc.

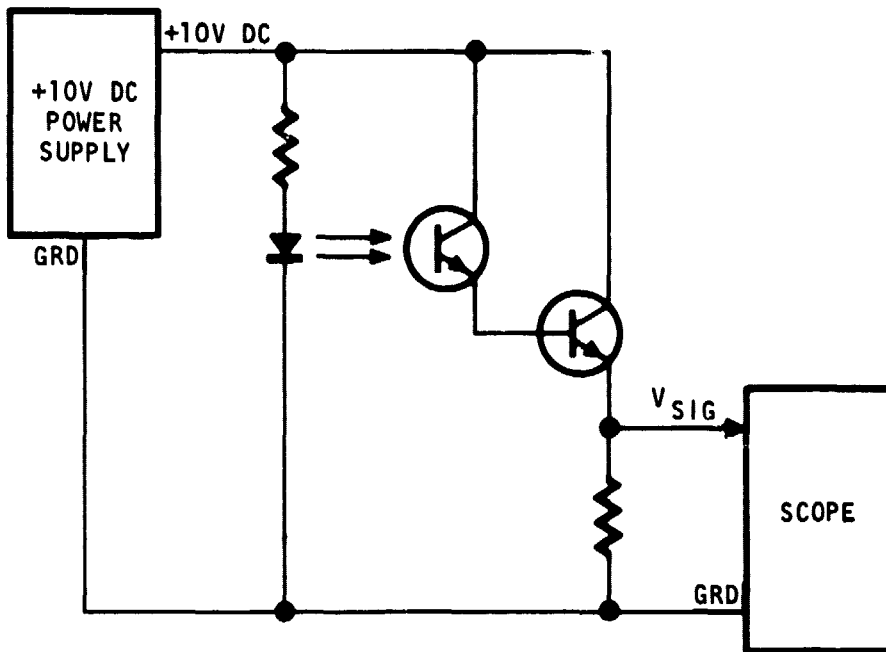

FIGURE 5-1. Shutter Speed Test Circuit

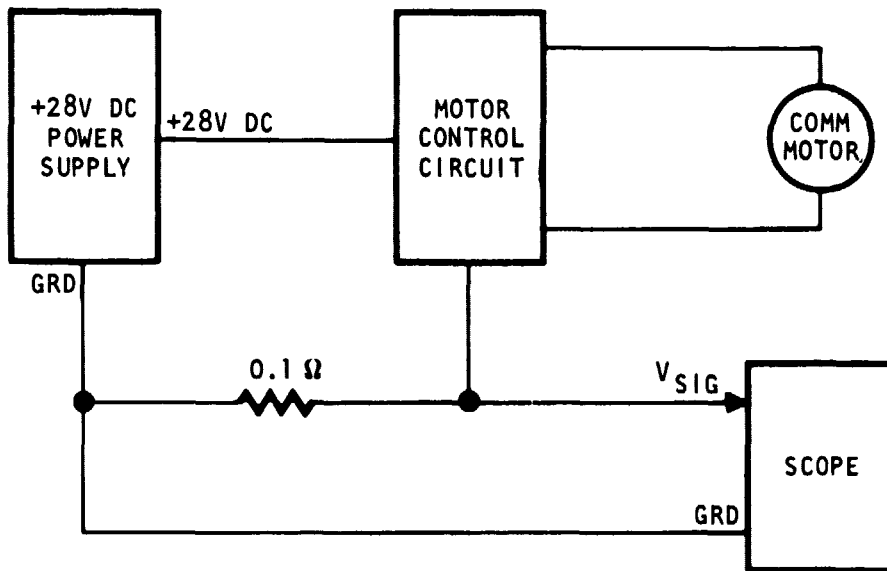

FIGURE 5-2. Input Current Test Circuit

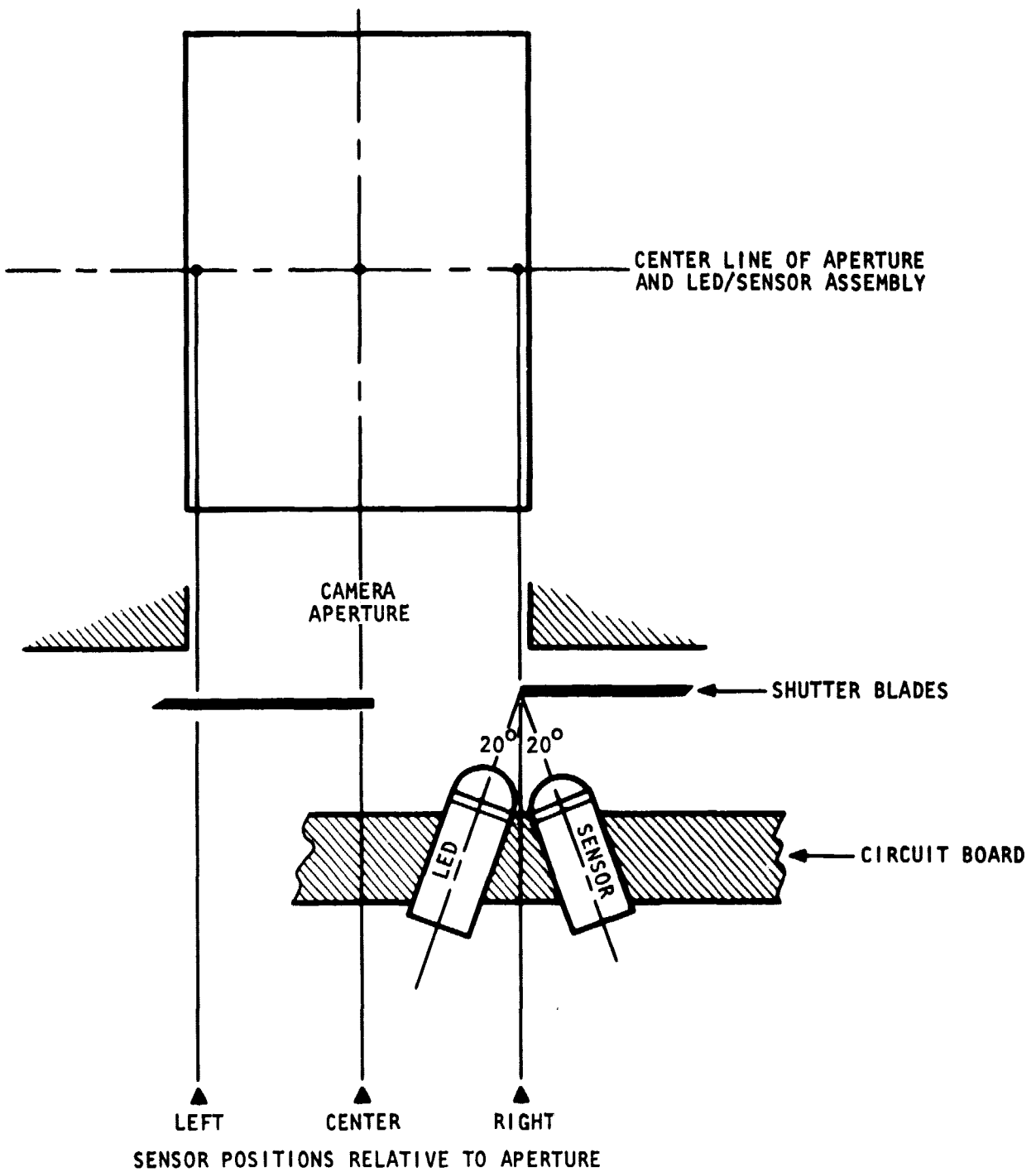

FIGURE 5-3. Optical Configuration for the Shutter Position Detector

5.3.5 START-UP TIME. The number of frames required to reach a constant shutter speed at frame rates of 2, 6, 12, and 24 ips was determined by observing the time relationship between the motor speed voltage waveform from the frequency/voltage converter and the shutter opening waveform from the shutter sensor. This method of testing shows whether or not the motor is up to speed when the shutter opens and how constant the motor speed is while the shutter is open.

5.3.6 CURRENT. Average current for each of the frame rates was obtained by reading an ammeter in series with the input power supply. Peak currents (start-up and running) were determined by measuring the voltage drop across a precision 0.1 ohm resistor in series with the power supply.

5.4 TEST RESULTS. Test results for the brassboard configuration are presented in Table 5-1. Shutter speeds were measured at the shutter opening extremes of 138° and 8.6° respectively.

A slight amount of jitter in frame to frame shutter speed variation was observed during the shutter speed test. The jitter is constant and does not vary with shutter angle. Therefore, the jitter is more evident at the narrower shutter angles. Motor speed ripple is the major cause of this jitter, which can be reduced by more precisely locating the motor velocity encoder wheel at the center of the motor shaft.

Shutter speed correlation when compared at various cinemode frame rates was consistent, i.e., 16 ms at 24 fps, 32 ms at 12 fps, and 64 ms at 6 fps using the 138° opening. This same pattern repeated at 8.6°, i.e., 1.0 ms at 24 fps, 2 ms at 12 fps, and 4 ms at 6 fps. The small amount of error noted in the readings is attributed to motor speed adjustment errors and therefore can be adjusted out.

The maximum frame rate achieved utilizing pulse mode operation was 3 fps. A base cinemode speed of 12 fps was used in this test. In order to achieve the 8 fps pulse rate, motor braking was required to stop the motor between frames. The high motor starting current and braking current for each frame increases the average current requirements while operating in the pulse mode.

The maximum frame rate achieved utilizing cinemode operation was approximately 80 fps. The corresponding input current was 320 mA. It should be noted that the motor and gearing used in the brassboard were not specifically designed for high speed cinemode operation, as this was not one of the objectives of the study. Higher speeds could certainly be obtained with a different design intended for this purpose.

The number of frames lost during start-up was determined as described in Paragraph 5.3.4. No frames were lost during start-up at 2, 6, and 12 fps. One frame was incorrectly exposed at 24 fps.

The current measurement data indicates that the maximum average current is 440 mA at the 6 fps pulse mode. However, operating at the 6 fps cinemode reduces maximum current to 190 mA. This reduction in current may warrant operating at 6 fps in cinemode and compensating for increased exposure time



TABLE 5-1

Electronically Commutated Motor Drive Test Results

Frame Rate (fps)	Shutter Opening (Degrees)	Exposure Time (ms)			Average Current (A)	Peak Current (A)		Line Voltage (V)	Remarks
		Left	Center	Right		Start	Run		
24	138	16.0	16.0	16.0	0.21	3.0	1.0	28	Cinemode
12	138	32.5	32.5	32.5	0.18	2.5	1.0	28	Cinemode
6	138	64.0	64.0	64.0	0.18	3.0	1.2	28	Cinemode
2	138	33.0	32.5	32.5	0.18	2.0	1.5	28	Pulse mode, base speed 12 fps
6	138	33.0	32.5	32.5	0.43	2.0	1.5	28	Pulse mode, base speed 12 fps
24	8.6	1.0	1.0	1.04				28	Cinemode
12	8.6	2.1	2.1	2.2				28	Cinemode
6	8.6	4.3	4.3	4.2				28	Cinemode
2	8.6	2.1	2.1	2.2				28	Pulse mode, base speed 12 fps
6	8.6	2.1	2.1	2.2				28	Pulse mode, base speed 12 fps
24	138	16.0	16.0	16.0	0.21	2.5	1.0	22	Cinemode
12	138	32.5	32.5	33.0	0.19	2.5	1.0	22	Cinemode
6	138	64.0	64.0	64.0	0.19	2.5	1.0	22	Cinemode
2	138	32.5	32.5	33.0	0.16	1.5	1.0	22	Pulse mode, base speed 12 fps
6	138	32.5	32.5	33.0	0.44	1.5	1.0	22	Pulse mode, base speed 12 fps
24	8.6	1.0	1.0	1.04				22	Cinemode
12	8.6	2.1	2.1	2.2				22	Cinemode
6	8.6	4.3	4.4	4.2				22	Cinemode
2	8.6	2.2	2.1	2.2				22	Pulse mode, base speed 12 fps
6	8.6	2.1	2.1	2.2				22	Pulse mode, base speed 12 fps
24	138	16.0	16.0	16.0	0.21	3.5	1.3	32	Cinemode
12	138	33.0	32.5	32.5	0.19	3.5	1.2	32	Cinemode
6	138	64.0	64.0	64.0	0.18	3.5	1.2	32	Cinemode
2	138	33.0	32.5	33	0.18	2.0	1.0	32	Pulse mode, base speed 12 fps
6	138	33.0	32.5	33	0.44	2.0	1.0	32	Pulse mode, base speed 12 fps
24	8.6	0.99	1.0	1.1				32	Cinemode
12	8.6	2.0	2.0	2.2				32	Cinemode
6	8.6	4.3	4.3	4.2				32	Cinemode
2	8.6	2.0	2.0	2.2				32	Pulse mode, base speed 12 fps
6	8.6	2.0	2.1	2.1				32	Pulse mode, base speed 12 fps

ORIGINAL PAGE IS  
OF POOR QUALITY

with an AEIC rather than operating at 6 fps in the pulse mode. Also, comparing the average breadboard currents with the average brassboard currents, it becomes very evident that the pulse width modulation motor speed control increases system efficiency.

The brassboard peak start-up currents are higher than the breadboard currents. However, tests show that the brassboard peak start-up currents can be limited to 1.5 amperes and still operate in the pulse mode with a base speed of 12 fps without any difficulty.

Measurements were also made of average input current at 24 fps with a 400 foot magazine on the brassboard. In all cases, the current did not exceed 300 mA, regardless of the distribution of the film between the supply and take-up rolls.

## 6. SUMMARY AND CONCLUSIONS

The primary goal of the study was to eliminate the brush type dc motor and the clutch from the 16 mm space sequential camera design. This final report covers the development of the most promising solution into a working camera system, and the results of the performance tests. Conclusions from the study and tests are:

- a. The brush type motor in the DAC can be replaced by an electronically commutated dc motor and the clutch can be eliminated, with only minor mechanical modifications to the camera, thus eliminating a major problem area.
- b. The electronic circuits necessary for the change can be packaged within the existing DAC body.
- c. In this design a shift in exposure of one stop occurs when changing between 24 fps and any of the other frame rates. Although the effect of this shift on photographic results will be negligible in most cases, it can be easily compensated for in cameras with AEC by automatically making a compensating adjustment in the iris setting.
- d. The new drive system reduces the current consumption at 24 fps to 220 mA, compared with an average of 500 mA for the standard DAC.
- e. The new design is capable of being programmed and controlled externally from the Multipurpose Programmable Timer/Intervalometer (MPTI), as well as being controlled locally from the camera.
- f. The new design has expansion capabilities to significantly higher frame rates without major modifications or loss in reliability.

In conclusion, this study has resulted in a design and brassboard which meet all of the program objectives, and which offer opportunities for expanded camera capabilities.