

NASA TECHNICAL NOTE

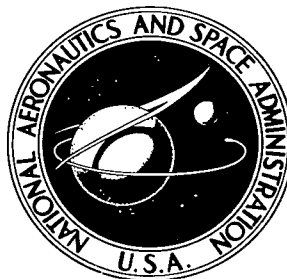

NASA TN D-8484

NASA TN D-8484

LOAN COPY: RE-
AFWL TECHNICAL
KIRTLAND AFB.



**FRICITION AND WEAR PROPERTIES
OF THREE HARD REFRACTORY COATINGS
APPLIED BY RADIOFREQUENCY SPUTTERING**

William A. Brainard
Lewis Research Center
Cleveland, Ohio 44135





0134206

1. Report No. NASA TN D-8484		2. Government Accession No.		3. Recipient's Catalog No.	
4. Title and Subtitle FRICTION AND WEAR PROPERTIES OF THREE HARD REFRACTORY COATINGS APPLIED BY RADIOFREQUENCY SPUTTERING				5. Report Date May 1977	
7. Author(s) William A. Brainard				6. Performing Organization Code	
9. Performing Organization Name and Address Lewis Research Center National Aeronautics and Space Administration Cleveland, Ohio 44135				8. Performing Organization Report No. E-9055	
12. Sponsoring Agency Name and Address National Aeronautics and Space Administration Washington, D. C. 20546				10. Work Unit No. 506-16	
15. Supplementary Notes				11. Contract or Grant No.	
16. Abstract The adherence, friction, and wear properties of thin hard refractory compound coatings applied to 440C bearing steel by radiofrequency sputtering were investigated. Friction and wear tests were done with nonconforming pin on disk specimens. The compounds examined were chromium carbide, molybdenum silicide, and titanium carbide. The adherence, friction, and wear were markedly improved by the application of a bias voltage to the bearing steel substrate during coating deposition. Analysis by X-ray photoelectron spectroscopy indicated that the improvement may be due to a reduction in impurities in bias deposited coatings. A fivefold reduction in oxygen concentration in MoSi ₂ coating by biasing was noted. Chromium carbide was not effective as an antiwear coating. Molybdenum silicide provided some reduction in both friction and wear. Titanium carbide exhibited excellent friction and antiwear properties at light loads. Plastic flow and transfer of the coating material onto the pin specimen appears to be important in achieving low friction and wear.				13. Type of Report and Period Covered Technical Note	
17. Key Words (Suggested by Author(s)) Friction Coatings Wear Refractory Sputtering				14. Sponsoring Agency Code	
19. Security Classif. (of this report) Unclassified		18. Distribution Statement Unclassified - unlimited STAR category 37		21. No. of Pages 19	
20. Security Classif. (of this page) Unclassified		22. Price* A02			

FRICITION AND WEAR PROPERTIES OF THREE HARD REFRACTORY COATINGS APPLIED BY RADIOFREQUENCY SPUTTERING

by William A. Brainard

Lewis Research Center

SUMMARY

The adherence, friction, and wear of three hard refractory compounds were investigated. These compounds were chromium carbide (Cr_3C_2), molybdenum silicide (MoSi_2), and titanium carbide (TiC). The compounds were applied to 440C bearing steel substrates by radiofrequency sputtering. Adherence tests were made to determine the influence of substrate cleaning and biasing. Biasing the substrate during deposition with -500 direct-current volts produced enhanced coating adherence, which resulted in lower friction and wear. Analysis of the sputtered films by X-ray photoelectron spectroscopy showed a higher amount of impurities in coatings that were not bias deposited. For MoSi_2 , the oxygen content of a bias coated sample was one-fifth that of nonbiased samples.

Full-scale friction and wear tests with nonconforming pin on disk configuration were conducted with bias deposited coatings of all three materials. The Cr_3C_2 coatings did not provide any reduction in friction or wear at the loads used. Molybdenum silicide coatings provided some reduction in both friction and wear. The TiC coating showed excellent friction and wear properties at loads below where coating failure occurred.

Additional friction and wear tests and X-ray analysis indicated that low friction and wear are associated with transfer of the coating material and the subsequent plastic flow of that material on the pin specimen.

INTRODUCTION

The use of hard coatings for improving wear resistance is commonly practiced. Coating of seals, cams, and valve heads are typical examples. Hardened surfaces are routinely prepared by conventional techniques such as carburizing or nitriding. Hard-faced coatings are applied by electroplating, arc welding, or plasma spraying (ref. 1). These methods of application are quite suitable for some applications but not for all.

The high temperatures required for furnace or plasma spraying methods preclude their use on some component or alloy systems. In addition, mechanical stresses can be induced in components due to thermal gradients introduced during the coating operation. Further, design considerations may require expensive grinding to finished dimensions depending on the precision of the part.

Coatings applied by vacuum deposition methods are generally thin enough ($<10 \mu\text{m}$) so that for all practical purposes the finished dimensions are unchanged by the coating process. In addition, the surface being coated is not subjected to the high temperatures required by other methods. Adherent, dense coatings of both metals and nonmetals can be applied by the vacuum deposition methods. In particular, refractory metal carbides, oxides, silicides, nitrides, and borides can be deposited by radiofrequency (rf) sputtering. These materials, as a class, constitute the hardest materials after diamond. (The hardness ranges from 1000 to 3000 kg/mm^2 (ref. 2).) Little work has been done on evaluating these materials as antiwear coatings when applied by rf sputtering. Some preliminary work (ref. 3) did indicate that pronounced improvement in ball-bearing life was obtained when bearing races and cages were precoated with a refractory silicide before being lubricated with molybdenum disulfide.

The objective of this investigation was to examine the adherence, friction, and wear properties of some refractory compounds applied by radiofrequency sputtering to a steel substrate. The materials chosen for this examination as thin sputtered coatings were chromium carbide (Cr_3C_2), molybdenum silicide (MoSi_2), and titanium carbide (TiC). These materials were evaluated as thin coatings on substrates of 440C bearing steel. A diamond stylus was used as the slider to determine adherence of the coatings. For friction and wear testing, metallic riders of 304 stainless steel were used.

APPARATUS AND PROCEDURE

Radiofrequency Sputtering Apparatus

The 440C disk specimens were coated by radiofrequency sputtering in a commercial diode system (fig. 1). The system included a modification that permitted a bias voltage (-500 to -1500 V dc) to be applied to the disk to provide for sputter cleaning with argon and for back-sputtering during deposition. The targets were commercially purchased hot pressed compacts, which were 15 centimeters in diameter. The sputtering parameters were kept constant: frequency, 13.8 megahertz; argon pressure, between 2.6 and 3.9 pascals (20 to 30 μm); and a power level, 450 watts. Specimen-to-target distance was normally 2.2 centimeters. Film thickness was determined by interference microscopy.

Friction and Wear Testing

Two devices were used to examine the adherence and friction and wear properties of these sputtered films.

In one device (fig. 2) a small friction and wear tester is incorporated into the specimen stage of a scanning electron microscope (SEM). The test specimens consisted of a 2.0-centimeter-diameter stainless-steel disk and a 25-micrometer-radius diamond stylus. The disk is mounted on an adapter to the rotary specimen feedthrough. The diamond stylus, which contacts the disk normally, is mounted in the end of an arm which projects into the chamber via a bellows from a gimbal system outside the chamber. The gimbal is controlled by a micrometer, which allows for precise positioning of the stylus on the disk. The arm contains two thinned flexible regions on which strain gages are mounted. The thinner regions are at 90° apart, so one gage reads the normal force (load), and the other reads tangential force (friction). Load was varied by a micrometer adjustment on the gimbal which causes the arm to press downward onto the disk. The applied load can be varied from 0.0098 to 1.96 newtons (1 to 200 g force). In this investigation loads of 0.098 to 0.882 newton (10 to 90 g) were used. The outputs from the two strain gages were amplified electronically and fed into an analog divider circuit, which was calibrated to give a direct digital display of the friction coefficient as well as a permanent record of it. All tests in the SEM chamber were conducted in a dry flowing nitrogen atmosphere rather than under vacuum, so conditions would be the same as for the full-scale components. Following the running of each of the specimens, the chamber was evacuated, and the wear tracks examined by scanning electron microscopy and X-ray dispersion analyzed. The specimens were then removed from the chamber and surface profiles of the wear tracks were taken. Friction coefficient, disk wear, and wear track appearance were noted for all tests.

The other device tested the films on large (6.4-cm diam) disk specimens in a pin on disk rig (fig. 3). The disk was hardened 440C stainless steel ($R_c = 55$ to 58), and the rider was an AISI 304 stainless steel bullet with a radius of 0.476 centimeter. The loads used were 0.49, 0.98, 1.96, and 4.9 newtons (50, 100, 200, and 500 g). The sliding speed was approximately 25 centimeters per second. The tests were for 60 minutes.

It is recognized that the pin on disk configuration provides extremely high contact stresses in contrast to the conforming type of contact. Because of the uncertainties with regard to modulus values for coated substrates, no attempts to calculate Hertzian stresses were made for the coated sample. Any coating that performs well under extremes such as exist in these test conditions would be expected to perform well or better under less severe conditions. Thus in this regard, the pin on disk test can be regarded as an upper-limit screening test for these coatings.

RESULTS AND DISCUSSION

Coating Adherence

In order for any coating to provide wear resistance, it must adhere to the surface to be protected from wear. Adherence is difficult to evaluate quantitatively, but several qualitative tests are used. The scratch test consists of drawing a stylus (diamond) across the coating at increasing loads until significant separation of the coating from the substrate occurs. This method has appeal for studying wear-resistant coatings because the test parallels a sliding friction experiment. The stresses are similar to those generated on an actual sliding surface. The scratch test was used to evaluate the adherence of sputtered coatings that were deposited under different conditions.

There are several sputtering parameters as well as substrate conditions that will affect coating adhesion. The first priority in studying thin, wear resistant coatings was to determine the sputtering conditions that would yield the best adherence. It is known from the literature (ref. 4) that sputter etching of the substrate will enhance adherence. Also, biasing the substrate with a negative potential during deposition is known to exert an influence of film properties. For example, biasing has been shown to affect the structure, electrical resistivity, impurity content, and stoichiometry of sputtered films (refs. 5 and 6). Both of these methods were used in order to determine their effectiveness. All other sputtering parameters were maintained at the previously discussed levels.

All coating materials were deposited both with sputter etching and biasing and also without biasing or etching. The same general results were obtained for all three materials. Figure 4 presents scanning electron micrographs of Cr_3C_2 coated specimens (440C stainless steel) after being scratched by the diamond stylus, which were typical of all three materials. One track was made on a film deposited with the specimen cleaned conventionally with solvents (fig. 4(a)). The other substrate was also solvent cleaned but was further prepared by dc sputter etching for 15 minutes in 2.6 pascals (20- μm of argon) at -1200 volts before the start of film deposition (fig. 4(b)). Both films are of approximately the same thickness.

At the 0.49-newton (50-g) load used, both films suffered appreciable fracturing and fragmentation. Although there appeared to be slightly less tendency for the fractured particles to separate from the surface for the etched case, the results are generally similar.

When a bias voltage of -500 volts was applied to the substrate during deposition, in addition to sputter etching, a marked improvement in film adherence was achieved (fig. 5). Wear tracks formed at 0.49 newton (50 g), the same load that was used for the other two cases, and at 0.882 newton (90 g) (fig. 5(b)) showed no evidence of coating fracture or fragmentation. X-ray analysis of the wear tracks indicates the track was

still coated, with Cr_3C_2 apparently having flowed plastically with the substrate during sliding contact. Similar improvements in adherence were obtained with all three materials tested. There are two possible nonexclusive explanations for the improvements obtained with biased films. First, back-sputtering (i. e., low-rate dc sputtering of the growing coating induced by the bias voltage) of the substrate during the initial stages of coating growth provides a "mixed" coating interface consisting of substrate material redepositing on itself along with target material. The second factor is impurity control. Even though high purity argon is used, outgassing products and pumping system contaminations can infiltrate the deposition process. The bias voltage on the substrate causes a continued, low-rate back-sputtering of the newly growing coating which serves to minimize impurities in the coating.

Preliminary data for the molybdenum silicide indicate that impurity concentration is higher in coatings that were deposited on nonbiased (grounded) substrates (ref. 7). Studies of MoSi_2 sputtered coatings conducted with X-ray photoelectron spectroscopy (XPS) showed a high concentration of oxygen in the grounded coating. The concentration of oxygen in the grounded coating was five times greater than in the biased coating. Chemical shift data indicates that the oxygen is chemically combined with silicon as an oxide. The biased coating also show the presence of iron. This may be supportive of the "mixing" explanation. Further work on the chemistry of the interface and degree of stoichiometry of these films is continuing. It is expected that similar effects would be observed with Cr_3C_2 and TiC .

Friction Results

The effectiveness of biasing in reducing friction and wear for large-scale pin on disk tests is demonstrated by the photomicrographs in figure 6. The disk was coated with titanium carbide. Both tracks were formed under identical conditions with the exception that one TiC film was bias deposited. The difference in wear is clear. In addition, the friction coefficient averaged 0.33 for the grounded coating and 0.28 for the biased coating, a 15 percent reduction. The effect of biasing the substrate could also be observed in the friction behavior. Figure 7 shows recorder tracings of friction coefficients for the diamond stylus sliding on two MoSi_2 films at a load of 0.19 newton (20 g). The grounded coatings exhibited a rough track characterizing a fracturing of the interface while the biased coatings exhibited a smooth constant friction coefficient, which is characteristic of plastic flow. Slight improvements in average friction coefficient were obtained for all three target materials. Thus, all subsequent friction and wear tests were done on coatings applied by sputter etching and biasing.

The 440C stainless steel surfaces were tested for microhardness before and after deposition. For the fully hardened 440C stainless-steel disks, the diamond pyramid

microhardness at a 1.47-newton (150-g) load was approximately 600±20 kilograms per square millimeter. After coating the disk to a thickness of 2500 to 3000 Å, microhardness did not increase for any of the three materials. In fact, a general trend was for the microhardness to be a few points lower after desposition (~560 kg/mm²). This effect was determined to be the result of surface annealing during sputter etching. An uncoated disk decreased slightly in microhardness if subjected to sputter-etching conditions used during actual coating procedures. Increasing the coating thickness to 8000 Å did not yield noticeable increases in microhardness. Thicker films, even bias deposited coatings, showed a much greater tendency toward fracture as a result of buildup of internal stress during coating growth.

Corresponding to the lack of surface hardening was a lack of improvement in abrasion resistance. Figure 8 shows the surface profiles of the scratch tests conducted on both uncoated and Cr₃C₂-coated annealed 440C at several loads. The scratch grooves are nearly identical even at the lightest loads used. The average friction values are shown above the respective load grooves in the figure. Similar results were obtained with the fully hardened 440C samples. The surface profiles for Cr₃C₂ coated samples are typical of those obtained for all three target materials. None provided significant reduction in surface abrasive damage on either annealed or hardened 440C stainless steel.

It must be recognized that the scratch test is especially severe, both in regard to stress and also with regard to the mechanical properties of the stylus. Regardless of the coating material, the diamond stylus is still at least twice as hard as the coating material. Therefore, the utility of the coating as a wear resistant coating may be considerably different in a metal-metal system where the stresses are much lower and a softer metallic rider is used.

Friction and Wear Results - Full Scale

To determine the behavior of these coatings for metal-metal systems, a series of runs was made with the full size pin on disk configurations at loads of 0.49, 0.98, 1.96, and 4.9 newtons (50, 100, 200, and 500 g) for 60 minutes. Friction and rider and disk wear were noted. All coatings used were bias deposited onto sputter-etched disks to approximately 3000 Å. The friction and rider wear results are summarized in figure 9. Also shown for comparison are data for the uncoated samples. It is clear that Cr₃C₂ coatings are of little value. Higher friction and no reduction in rider or disk wear were obtained with that coating. Films of MoSi₂, however, provided reduced friction and rider wear but produced marked disk wear (fig. 10).

Coatings of titanium carbide (TiC) provided excellent wear protection and low friction at loads up to 1.96 newtons (200 g). Both friction and rider wear are only about



one third the uncoated values. In addition, disk wear was unmeasurably small. The friction force was very smooth the entire run for the 0.49- and 0.98-newton (50- and 100-g) load experiments. At 1.96 newtons (200 g) the friction force began to roughen, and the average increased as some coating failure was experienced, although both rider and disk wear were lower than for the uncoated case.

At the 4.9-newton (500-g) load almost total coating failure occurred, resulting in catastrophic disk wear (fig. 11). Also shown in this figure are traces for the uncoated disk and the MoSi_2 coated disk. Note that the vertical magnification for the TiC track is only one fifth that of the other profiles. During coating failure, small fragments of the coating break off the disk and are picked up by the rider. These fragments abrasively wear the disk. The microhardness of TiC is 3200 kilograms per square millimeter (ref. 8); the microhardnesses of MoSi_2 and Cr_3C_2 , range between 1200 and 1350 kilograms per square millimeter. The rather severe disk wear for TiC at the 4.9-newton (500-g) load is likely due to the very hard nature of the fragmented coating particles. A photomicrograph (fig. 12) shows a typical collection of coating fragments surrounding the rider wear scar. Both large and small fragments are present. With continued sliding, these particles continue to break up, and some become squeezed in the contact region. These then may act as abrasive cutting edges or may undergo plastic deformation and form polished films or layers. The formation of polished layers was confirmed by X-ray analysis of the rider scar. Such a polishing process has been observed with a tungsten carbide cermet (ref. 10): The polished layer promoted both lower wear and friction. In that investigation dynamic SEM studies showed that the tungsten carbide phase exhibited extensive plastic behavior even exhibiting ductile fracture along slip boundaries.

What appears to happen with TiC at the lighter loads is that some coating material adheres to the rider and is subjected to plastic flow, forming a dense TiC transfer film (fig. 13). The wear situation becomes TiC sliding on TiC, which results in low wear for both rider and disk. At higher loads, sufficient coating separation from the substrate occurs, exposing bare 440C to the TiC fragments and transfer films. This leads to accelerated wear of the 440C disk at loads of 1.96 newtons (200 g) and more. The Cr_3C_2 and MoSi_2 did not exhibit transfer into the AISI 304 rider.

Since this ability to form a transfer film on the rider may be beneficial to lower friction and wear, different rider materials were run against coatings of Cr_3C_2 and MoSi_2 to see if transfer films would form. Tungsten, tantalum, aluminum, and copper riders were run at 0.98-newton (100-g) loads against disks that were bias coated with 3000 Å thick coatings of Cr_3C_2 and MoSi_2 .

After testing, the riders were examined by SEM and X-ray analysis to determine the extent of transfer-film formation, if any. It was found that the tungsten and tantalum behavior were similar to that of the 304 rider. No dense transfer film was obtained for either Cr_3C_2 or MoSi_2 . Rather, a loose agglomeration of transferred particles forming

a pockmarked surface was observed (fig. 14). An aluminum rider (fig. 14(a)) showed some formation of a dense film; however, the wear of the aluminum may have been too great for the process to have reached equilibrium. Copper riders, in contrast, exhibited a smooth dense transfer film after running both on Cr_3C_2 and MoSi_2 films. The X-ray analysis showed the transfer to be coating material flowed with copper. Some iron, from the 440C disk, was also observed. A typical copper rider wear surface is shown in figure 14(c). Copper riders showed the lowest friction of all rider materials (0.42) for both Cr_3C_2 and MoSi_2 coatings. The low shear strength copper provided a means of forming the polished transfer film much the way the cobalt binder in tungsten carbide cermets was found to do (ref. 9). Such results indicate the importance of materials selection when using hard coatings in a wearing situation.

SUMMARY OF RESULTS

Tests on the adherence, friction, and wear properties of thin, hard refractory compound coatings applied to 440C bearing steel by radiofrequency sputtering yielded the following results:

1. Biasing the 440C bearing steel substrate with -500 volts during sputter deposition produced coatings significantly better adherence than those obtained with the substrate at ground potential. The improved adherence resulted in smoother and lower friction and lower wear.
2. X-ray photoelectron spectroscopy studies of films deposited by biasing indicate a significantly lower concentration of impurity. The oxygen concentration in bias deposited molybdenum disulfide coatings was 20 percent of that of nonbiased coatings.
3. For the materials examined, films up to 8000 Å thick did not produce significant increases in diamond pyramid microhardness (150 g) or in abrasion resistance to a diamond stylus, although significant reduction in friction and wear was obtained for metal-metal combinations.
4. For the metal-metal combination of 304 stainless steel on 440C, both molybdenum disulfide and titanium carbide reduced friction and wear. Chromium carbide was not effective in reducing wear or friction.
5. Plasticity and transfer of the coating material appear to be significant factors for achieving low friction and wear properties of hard refractory coatings.

Lewis Research Center,
National Aeronautics and Space Administration,
Cleveland, Ohio, February 4, 1977,
506-16.

REFERENCES

1. Donovan, M.; and Sanders, J. L.: Surface Coating. I - Introduction. Tribology, vol. 5, no. 5, Oct. 1972, pp. 205-206.
2. Lynch, James F.; Ruderer, Clifford G.; and Duckworth, Winston H.: Engineering Properties of Ceramics - Databook to Guide Materials Selection for Structural Application. Battelle Memorial Inst. (AFML-TR-66-52; AD-803765), 1966.
3. Spalvins, Talivaldis: Bearing Endurance Tests in Vacuum for Sputtered Molybdenum Disulfide Films. NASA TM X-3193, 1975.
4. Thornton, J. A.: Sputter Coating - Its Principles and Potential. SAE Paper 730544, May 1973.
5. Christensen, Orla: Characteristics and Applications of Bias Sputtering. Solid State Technol., vol. 13, no. 12, Dec. 1970, pp. 39-45.
6. Vossen, J. L.; and O'Neil, J. J., Jr.: D. C. Sputtering with RF-Induced Substrate Bias. RCA Rev., vol. 29, no. 4, Dec. 1968, pp. 566-581.
7. Wheeler, D. H.; and Brainard, W. A.: X-ray Photoelectron Spectroscopy Study of Radiofrequency Sputtered Chromium Bromide, Molybdenum Disilicide, and Molybdenum Disulfide Coatings and Their Friction Properties. NASA TN D-8482, 1977.
8. Westbrook, J. H.; and Stover, E. R.: Carbides for High-Temperature Applications. High-Temperature Materials and Technology. Inor E. Campbell and Edwin M. Sherwood, eds., John Wiley & Sons, Inc., 1967, pp. 312-348.
9. Samsonov, G. V.: Handbook of High-Temperature Materials. Vol. 2: Properties Index. Plenum Press, 1964.
10. Brainard, William A.; and Buckley, Donald H.: Dynamic SEM Wear Studies of Tungsten Carbide Cermets. ASLE Trans., vol. 19, no. 4, Oct. 1976, pp. 309-318.

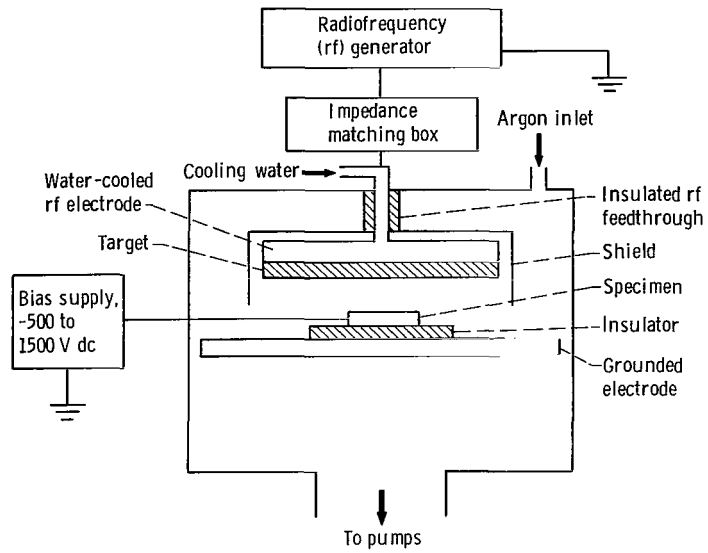
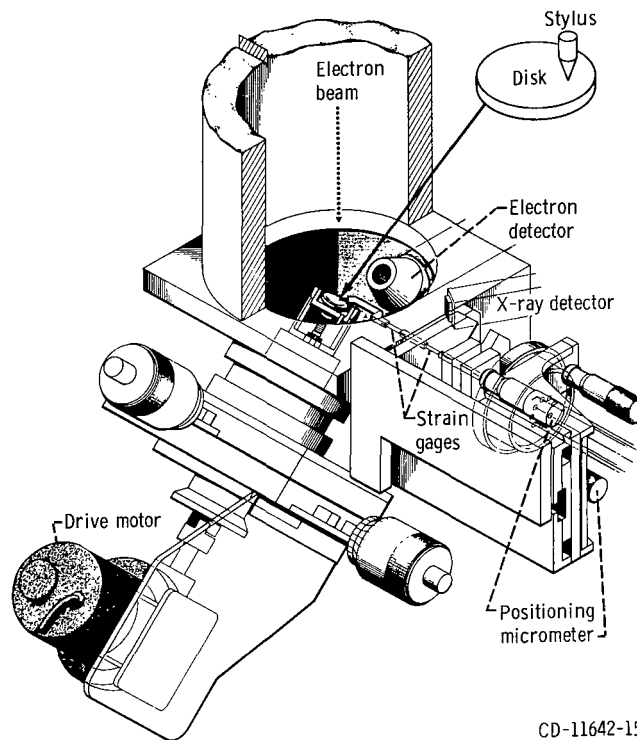

Figure 1. - Schematic of radiofrequency sputtering apparatus.



CD-11642-15

Figure 2. - Detailed drawing of friction apparatus mounted on scanning electron microscope.

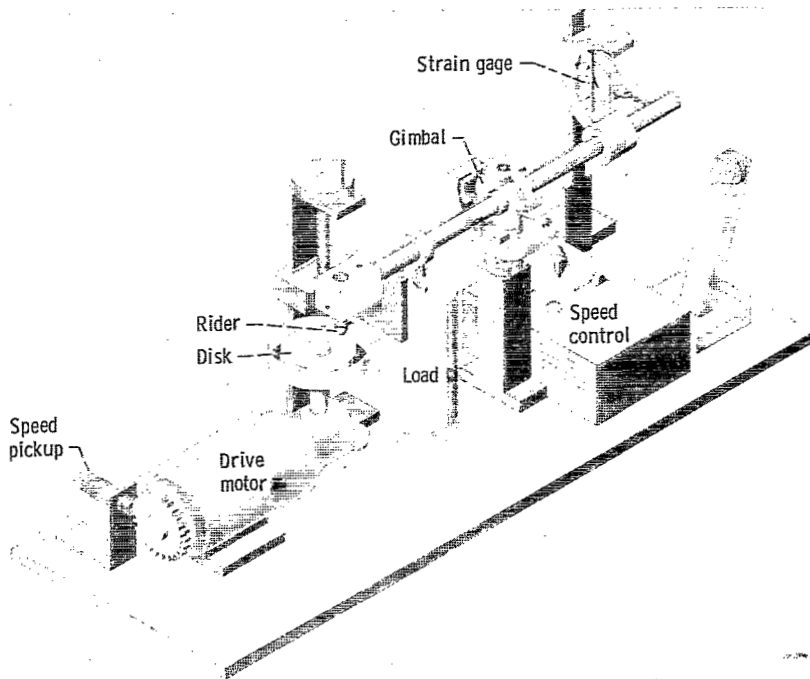
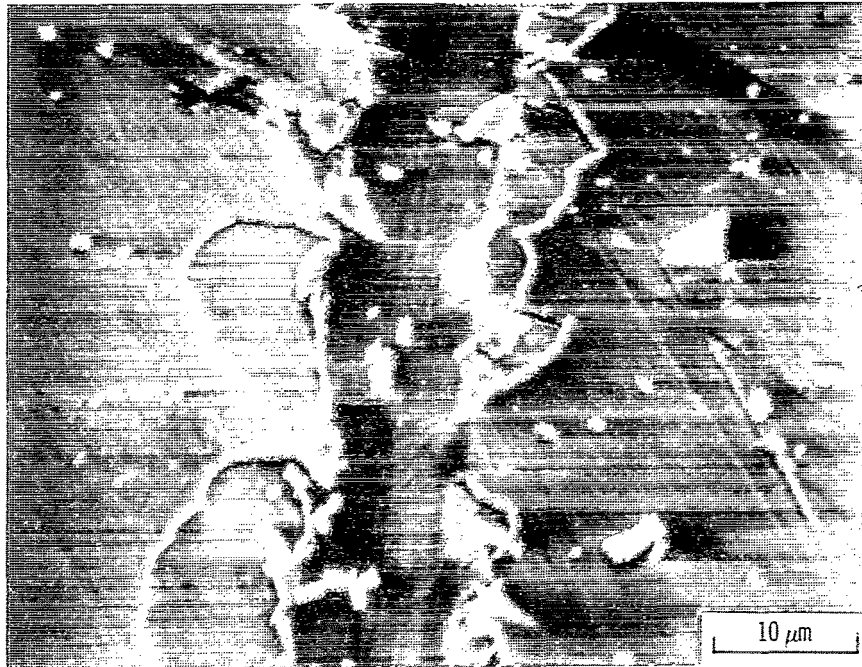
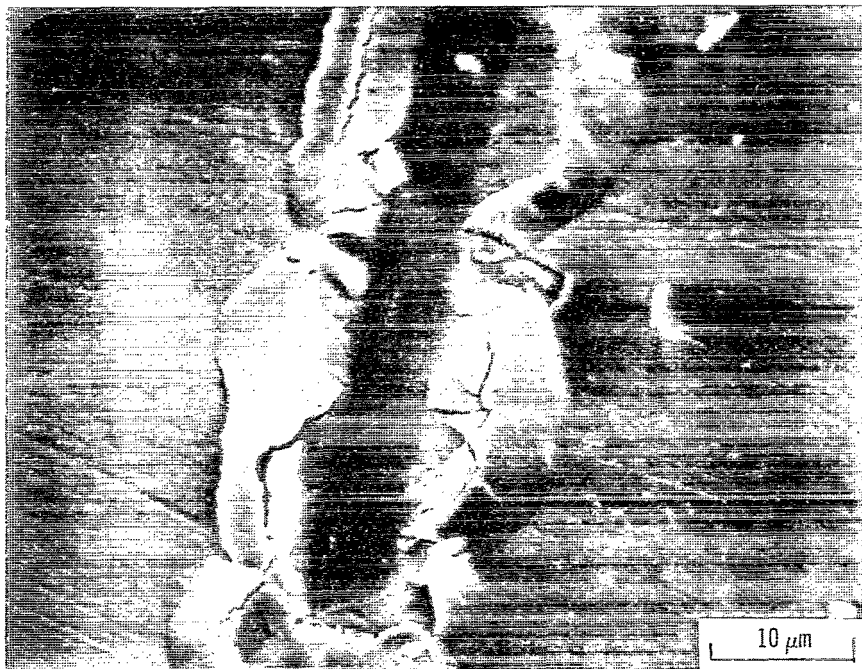

Figure 3. - Pin on disk friction and wear tester.



(a) No etching or biasing.



(b) Sputter etched.

Figure 4. - Friction tracks generated on chromium carbide sputter-coated 440C stainless steel. Diamond stylus radius, 25 micrometers; load, 0.49 newton (50 g).

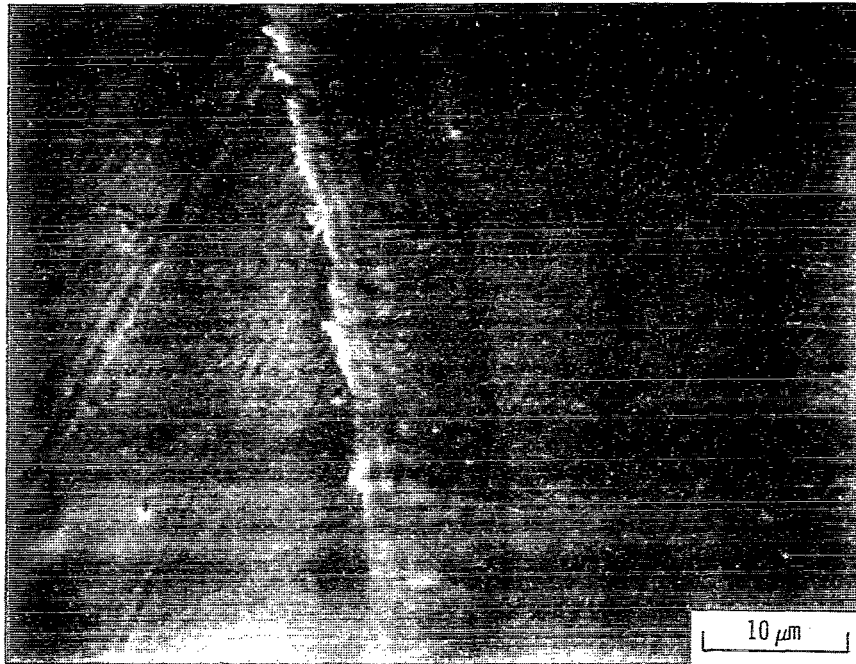

(a) Load, 0.49 newton (50 g).

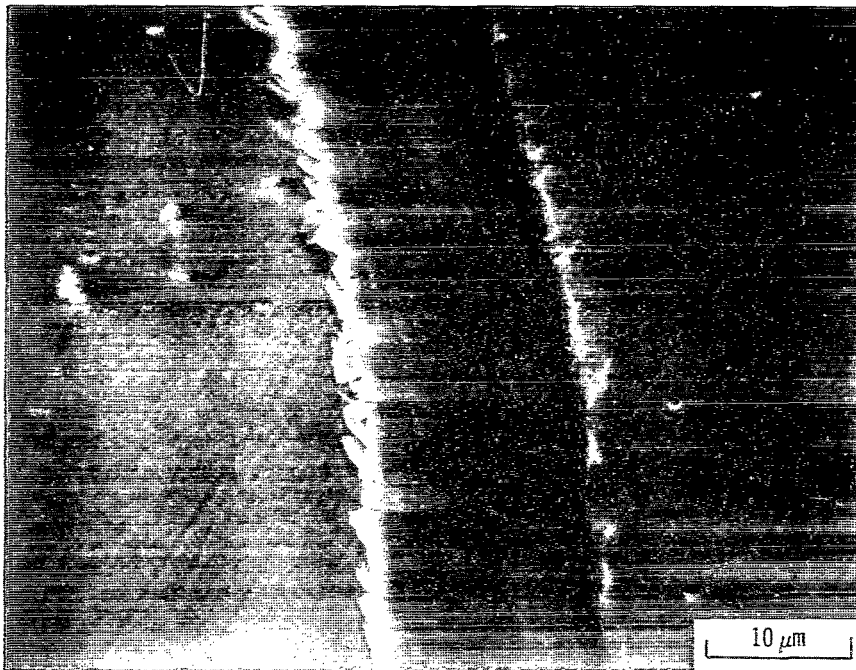

(b) Load, 0.88 newton (90 g).

Figure 5. - Friction tracks generated on chromium carbide coated, sputter-etched and biased (-500 V) 440C stainless steel.

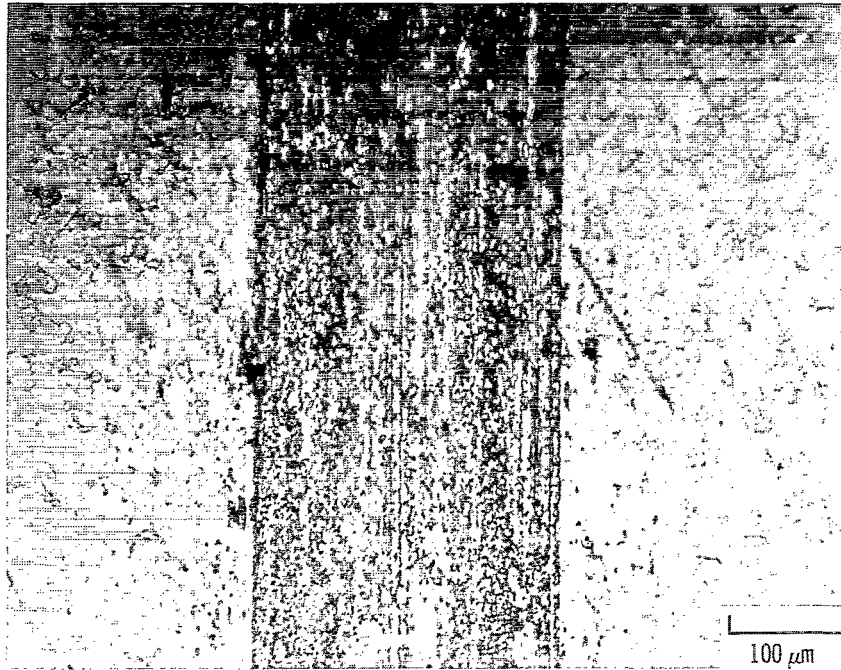

(a) Ground

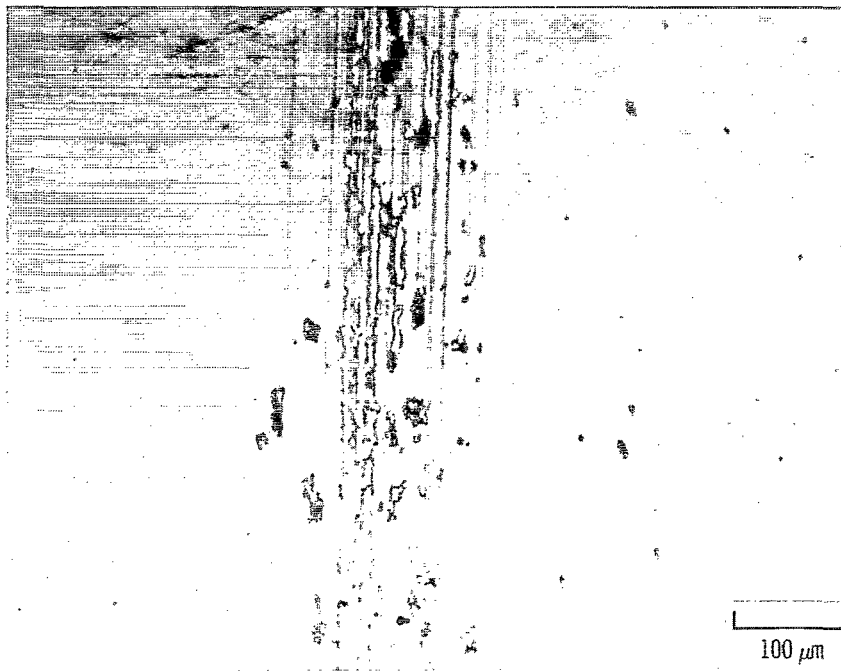

(b) Biased (-500 V)

Figure 6. - Wear tracks for titanium carbide sputter-coated 440C stainless steel disk. Rider material, AISI 304 stainless steel; load, 0.49 newton (50 g); atmosphere, nitrogen.

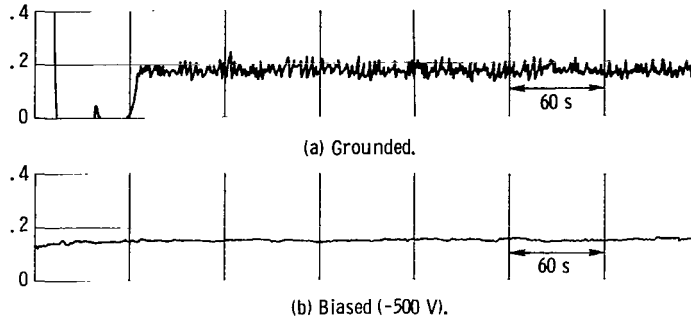

Figure 7. - Friction coefficient for molybdenum silicide sputter-coated 440C stainless-steel disk. Diamond stylus radius, 25 micrometers; stylus load, 0.20 newton (20 g); atmosphere, nitrogen.

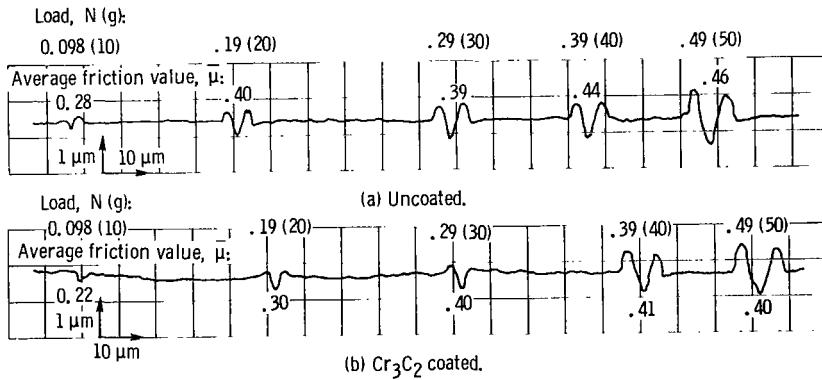

Figure 8. - Surface profiles from scratch test of uncoated and coated, annealed 440C stainless-steel disk. Diamond stylus radius, 25 micrometers; 440C microhardness, 260 kilograms per square millimeter.

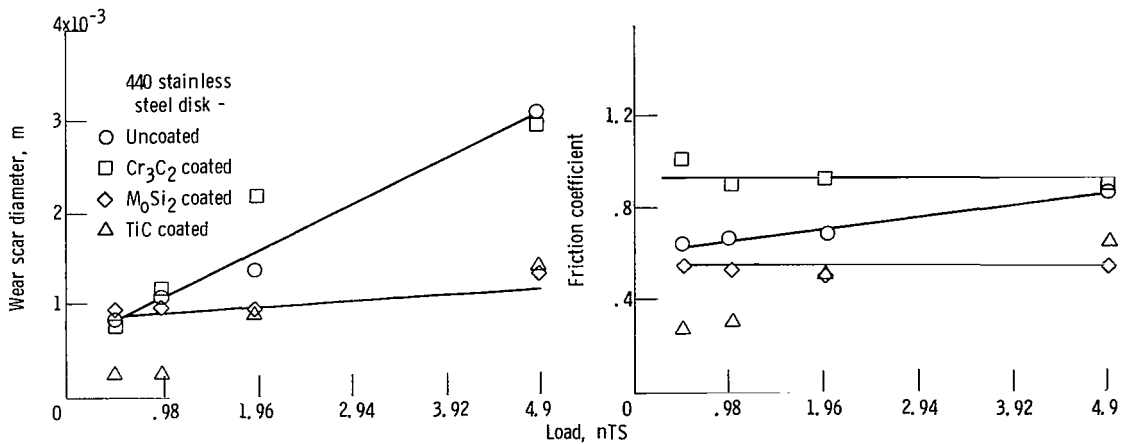

Figure 9. - Friction coefficient and rider wear as functions of load. Rider material, AISI 304 stainless steel; atmosphere, nitrogen; test duration, 60 minutes; sliding speed, 25 centimeters per second.

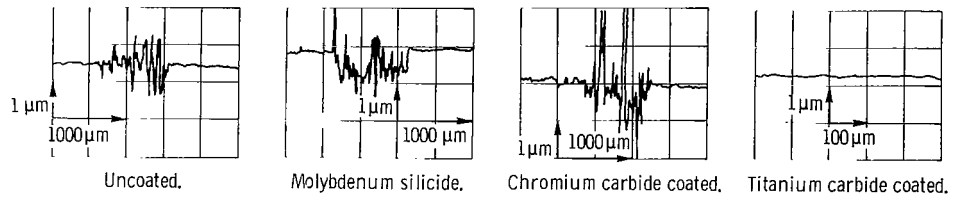

Figure 10. - Surface wear profiles for 440C disks with various coatings. Load, 0.49 newton (50 g) atmosphere, nitrogen.

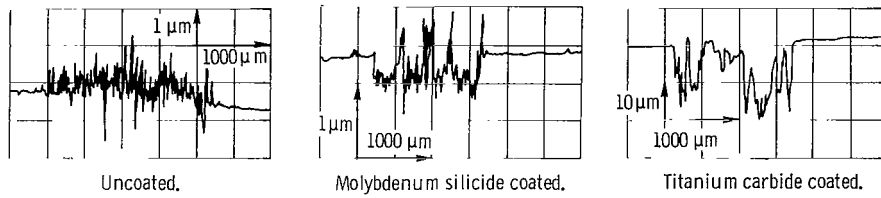

Figure 11. - Surface profile of coated 440C stainless-steel disk wear track. Load, 4.9 newtons (500 g) with titanium carbide film. Atmosphere, nitrogen; rider material, AISI 304 stainless steel.



Figure 12. - Molybdenum silicide wear debris adhering to rider after running.

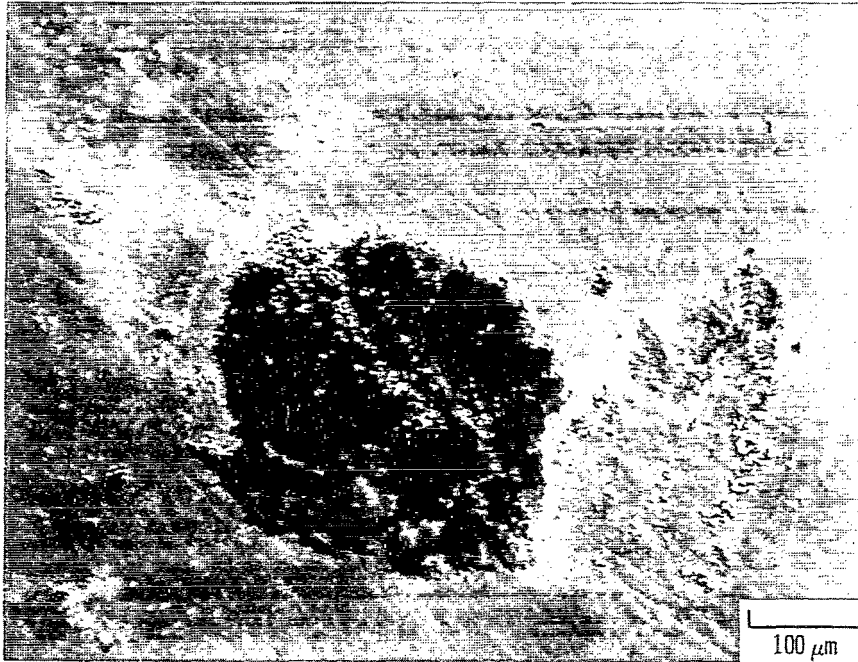
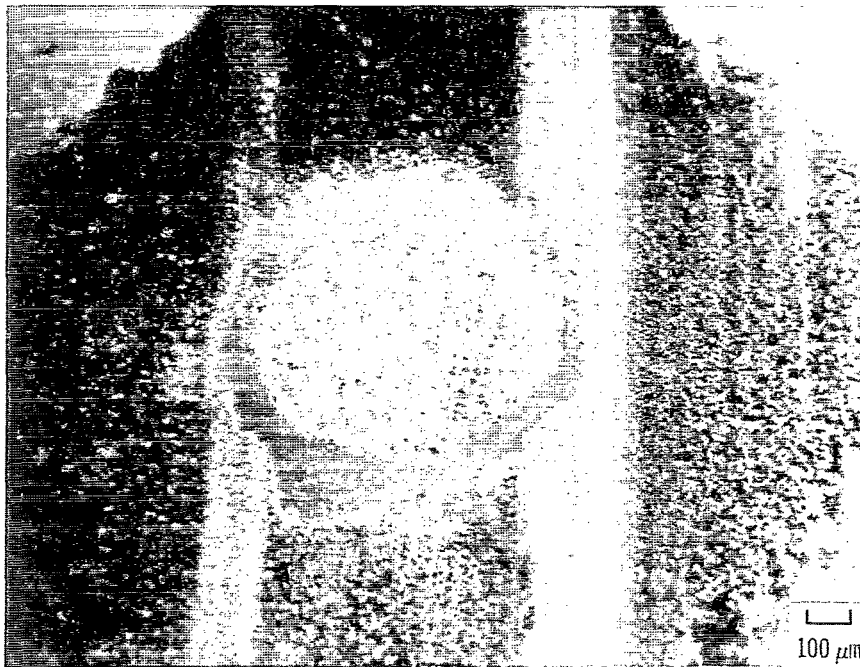

Figure 13. - Photomicrograph of 304 stainless steel rider after running against titanium carbide coated 440C disks. Load, 0.98 newton (100 g).



(a) Aluminum rider on chromium carbide coated disk.

Figure 14. - Photomicrographs of riders after running on coated 440C stainless steel disks. Load, 0.98 newton (100 g).



(b) Tungsten rider run on molybdenum silicide coated disk.

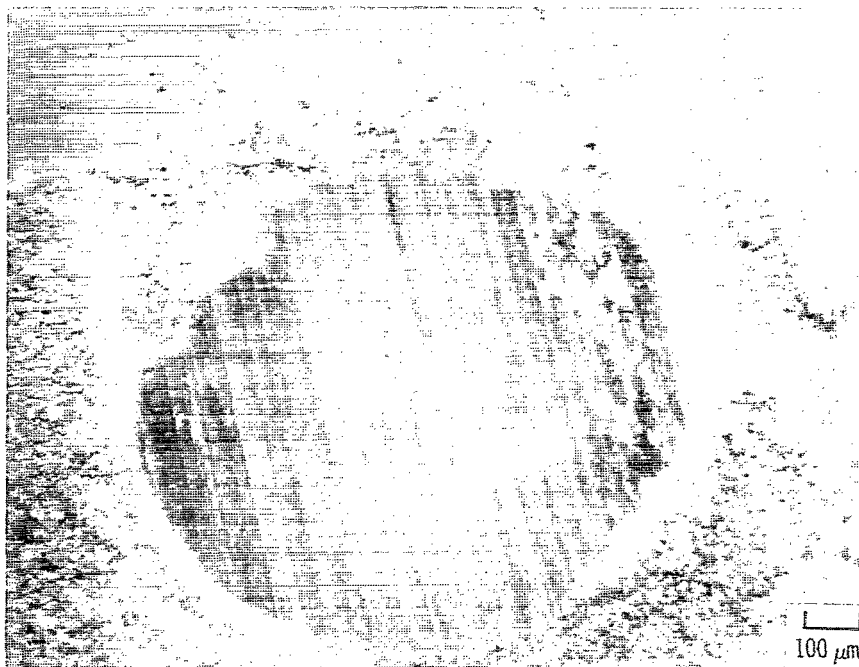

(c) Copper rider on chromium carbide coated disk.

Figure 14. - Concluded.



321 001 C1 U D 770429 S00903DS
DEPT OF THE AIR FORCE
AF WEAPONS LABORATORY
ATTN: TECHNICAL LIBRARY (SUL)
KIRTLAND AFB NM 87117

POSTMASTER: If Undeliverable (Section 158
Postal Manual) Do Not Return

"The aeronautical and space activities of the United States shall be conducted so as to contribute . . . to the expansion of human knowledge of phenomena in the atmosphere and space. The Administration shall provide for the widest practicable and appropriate dissemination of information concerning its activities and the results thereof."

—NATIONAL AERONAUTICS AND SPACE ACT OF 1958

NASA SCIENTIFIC AND TECHNICAL PUBLICATIONS

TECHNICAL REPORTS: Scientific and technical information considered important, complete, and a lasting contribution to existing knowledge.

TECHNICAL NOTES: Information less broad in scope but nevertheless of importance as a contribution to existing knowledge.

TECHNICAL MEMORANDUMS: Information receiving limited distribution because of preliminary data, security classification, or other reasons. Also includes conference proceedings with either limited or unlimited distribution.

CONTRACTOR REPORTS: Scientific and technical information generated under a NASA contract or grant and considered an important contribution to existing knowledge.

TECHNICAL TRANSLATIONS: Information published in a foreign language considered to merit NASA distribution in English.

SPECIAL PUBLICATIONS: Information derived from or of value to NASA activities. Publications include final reports of major projects, monographs, data compilations, handbooks, sourcebooks, and special bibliographies.

TECHNOLOGY UTILIZATION PUBLICATIONS: Information on technology used by NASA that may be of particular interest in commercial and other non-aerospace applications. Publications include Tech Briefs, Technology Utilization Reports and Technology Surveys.

Details on the availability of these publications may be obtained from:

SCIENTIFIC AND TECHNICAL INFORMATION OFFICE

NATIONAL AERONAUTICS AND SPACE ADMINISTRATION

Washington, D.C. 20546