

NASA TECHNICAL NOTE



NASA TN D-8497

NASA TN D-8497

**NASA FIREFIGHTERS
BREATHING SYSTEM
PROGRAM REPORT**

William B. Wood

*Lyndon B. Johnson Space Center
Houston, Texas 77058*

1. Report No. TN D-8497		2. Government Accession No.		3. Recipient's Catalog No.	
4. Title and Subtitle NASA FIREFIGHTERS BREATHING SYSTEM PROGRAM REPORT				5. Report Date May 1977	
				6. Performing Organization Code JSC-11321	
7. Author(s) William B. Wood				8. Performing Organization Report No. S-465	
9. Performing Organization Name and Address Lyndon B. Johnson Space Center Houston, Texas 77058				10. Work Unit No. 141-95-01-41-72	
				11. Contract or Grant No.	
12. Sponsoring Agency Name and Address National Aeronautics and Space Administration Washington, D. C. 20546				13. Type of Report and Period Covered Technical Note	
				14. Sponsoring Agency Code	
15. Supplementary Notes					
16. Abstract Because of the rising incidence of respiratory injury to firefighters, local governments expressed the need for improved breathing apparatus. In response to this need, the Crew Systems Division of the NASA Lyndon B. Johnson Space Center designed and developed the NASA prototype firefighters breathing system. This document contains a review of the NASA firefighters breathing system program, including concept definition, design, development, regulatory agency approval, in-house testing, and program conclusion.					
17. Key Words (Suggested by Author(s)) Firefighting Flow regulators Respirators Open-loop systems Breathing apparatus Portable life-support systems			18. Distribution Statement STAR Subject Category: 54 (Man/System Technology and Life Support) 85 (Urban Technology and Transportation)		
19. Security Classif. (of this report) Unclassified		20. Security Classif. (of this page) Unclassified		21. No. of Pages 71	22. Price* \$4.50

**Page
Intentionally
Left Blank**

CONTENTS

Section	Page
SUMMARY	1
INTRODUCTION	1
NASA FBS PROGRAM	3
Concept Definition	4
Design Phase	7
Development Phase	11
Regulatory Agency Approvals	22
Field Evaluation	26
CONCLUSIONS AND RECOMMENDATIONS	31
REFERENCES	35
APPENDIX A — BUREAU OF EXPLOSIVES SAFETY RELIEF DEVICE APPROVAL	A-1
APPENDIX B — DEPARTMENT OF TRANSPORTATION SPECIAL PERMIT NO. 6747	B-1
APPENDIX C — FIELD EVALUATION SITE DESCRIPTION	C-1
APPENDIX D — FIELD EVALUATION SUPPORT EQUIPMENT	D-1
APPENDIX E — FIELD EVALUATION SUMMARY	E-1

TABLES

Table		Page
I	TYPICAL FBS COMPONENT WEIGHTS	11
II	PRESSURE VESSEL DESIGN SUMMARY	12
III	PRESSURE VESSEL STRESSES — CYLINDRICAL SECTION	13
IV	RESULTS OF NASA MANNED FBS TESTING	15
V	SUMMARY OF HFTA TEST RESULTS	16
VI	TYPICAL PERFORMANCE DATA	17
VII	MARTIN MARIETTA QUALIFICATION TESTING	18
VIII	PRESSURIZATION HISTORY OF VESSELS RETURNED FROM LEWIS RESEARCH CENTER	20
IX	SCI QUALIFICATION TESTING	21
X	POST-FIELD-EVALUATION BURST TESTS	23
XI	FLAME TEST PRESSURE AND TEMPERATURE	24
XII	FBS PRODUCT IMPROVEMENT RECOMMENDATIONS	32
E-I	FBS POST-FIELD-EVALUATION INTERVIEW SUMMARY	E-1

FIGURES

Figure		Page
1	Lunar exploration life-support system	2
2	Open-loop system schematic	4
3	Closed- and semi-closed-loop system schematic	4
4	NASA FBS equipment	8
5	NASA FBS (donned)	
	(a) Front view	8
	(b) Profile	8

6	NASA FBS face mask and demand regulator	
	(a) Photograph	9
	(b) Sketch	9
7	NASA FBS schematic	10
8	Flame test setup	24
9	NIOSH approvals	25
C-1	Houston firetruck layout, Engine Companies 16 and 28.	C-5
C-2	New York firetruck layout, Ladder Company 19	C-5
C-3	New York firetruck layout, Squad Company 4	C-5
C-4	Los Angeles firetruck layout, Task Force 27	
	(a) Engine Company 27	C-5
	(b) Engine Company 227	C-5
	(c) Truck Company 27	C-5
D-1	Cascade charging station schematic	D-3
D-2	Aminco charging station schematic	D-4
D-3	Type I FBS test stand	D-5
D-4	Type II FBS test stand	D-6
E-1	Sample FBS post-field-evaluation debriefing form	E-5

NASA FIREFIGHTERS BREATHING SYSTEM

PROGRAM REPORT

By William B. Wood
Lyndon B. Johnson Space Center

SUMMARY

The NASA firefighters breathing system is a result of public needs being satisfied through the application of advanced aerospace technology. Industrial applications of advanced technology have normally progressed rapidly. However, with radical changes in materials and processes, industrial research and development budgets have occasionally limited the speed of technology application. Current breathing systems do not use technological advancements in the application of materials to achieve a reduction in weight or an increase in gas storage pressures and durations. The NASA firefighters breathing system has coupled this application of materials with qualified design concepts for pressure reduction and gas delivery to the user. These designs were verified by field evaluations conducted at fire departments and have resulted in an improved breathing apparatus. This document provides a review of the NASA firefighters breathing system program, including concept definition, design, development, regulatory agency approval, in-house testing, and program conclusion. Program documentation is available to potential manufacturers and users.

INTRODUCTION

The NASA makes its advanced aerospace technology available to the public through its Technology Utilization Program. A review of current public requirements by municipal officials at a Technology Utilization Conference held at the NASA John F. Kennedy Space Center (KSC) in 1970 indicated a growing demand by the firefighting service for improved breathing systems. The need for an improved firefighters breathing system (FBS) is best illustrated by the fact that every year 10 percent of the nation's paid firefighters sustain some type of respiratory injury. This figure is based on the 1973 Annual Death and Injury Survey conducted by the International Association of Firefighters. The evidence indicates that, even though fire departments have been equipped with self-contained breathing apparatus for several years, the trend of respiratory injury is rising. The conclusion is that firefighters do not fully utilize their breathing apparatus because of weight, bulk, and restricted maneuverability.

Following the 1970 conference, a User Requirements Committee composed of nationwide city administrators and professional fire service personnel was established. The purpose of the committee was to define user requirements to be used as guidelines in the design and development of an improved breathing system. The committee established the requirements for an improved breathing system that would meet the needs of the cities and ensured that the design would be acceptable to the fire service and the cities from both an operational and an economic perspective. Studies indicated that state-of-the-art technology could meet the committee's requirements, and the NASA Lyndon B. Johnson Space Center (JSC) was asked to manage the development of an improved FBS.

The development of the FBS required a systems engineering approach similar to that used by the Crew Systems Division at JSC for the development of the life-support system for the Apollo lunar exploration missions. The major components of this system are shown in figure 1 and described as follows.

1. The portable life-support system is a back-mounted life-support system that provides breathing oxygen for the astronaut and pressurization for the suit. It also removes carbon dioxide and provides cooling and communications for as long as 7 hours.

2. The oxygen purge system is mounted on top of the portable life-support system and supplies oxygen for 30 minutes in the event of primary system failure.

3. The pressure garment assembly, more commonly known as the space suit, protects the astronaut from exposure to space vacuum and the temperature extremes of the lunar surface while providing him the mobility to perform lunar exploration.

The Crew Systems Division was also responsible for the development of extravehicular life-support systems for the Gemini and Skylab Programs. Crew Systems Division personnel were required to determine the physiological needs of astronauts working in extremely hostile environments, to develop lightweight systems to satisfy these needs, and to operate the systems successfully during space missions. In addition to these responsibilities, the Crew Systems Division has the engineering responsibility for development of all environmental control systems used on U.S. manned space vehicles.



Figure 1.- Lunar exploration life-support system.

The NASA JSC explored several alternative design concepts before selecting the open-loop system as the approach that best met the firefighters' needs. An open-loop system was chosen because significant improvements in weight, bulk, and duration of operation could be achieved with high reliability, ease of maintenance and operation, and relatively low initial and recharging costs.

The NASA prototype breathing apparatus was extensively tested to meet NASA system qualification demands and various regulatory agency requirements. A 6-month field evaluation was conducted during which the NASA prototype FBS was used more than 2000 times as firstline suppression equipment in some of the busiest and most diversified engine and ladder companies in the world. This evaluation, conducted in Houston, Los Angeles, and New York, allowed NASA to prove the design concept in actual firefighting conditions. Comments from firefighters who used the FBS in fighting fires have been overwhelmingly positive; reduced weight, greater maneuverability, and lower breathing resistance are the most frequently mentioned attributes. The prototype units have been enthusiastically reviewed at regional demonstrations by professional fire service personnel.

The end products of the FBS program are prototype breathing systems that are fully qualified by testing and field evaluation and approved by cognizant regulatory agencies, development reports, guideline procurement specifications, and a program report. Program documentation, including drawings and specifications of developed components and systems, is available to potential manufacturers and users from the NASA Technology Utilization Office.

As an aid to the reader, where necessary the original units of measure have been converted to the equivalent value in the Système International d'Unités (SI). The SI units are written first, and the original units are written parenthetically thereafter.

NASA FBS PROGRAM

The primary objective of the NASA FBS program was to develop an improved breathing system to satisfy the operational requirements of fire departments while remaining within their cost constraints. A secondary objective was to assist in the acceptance and implementation of the improved breathing system by coordinating regulatory agency approval and conducting a field evaluation program. The definitions of general requirements for an improved system that were established by the User Requirements Committee were used in achieving these objectives. User comments revealed that the primary areas of concern to firefighters were system weight, system bulk, operating duration, human factors, and component performance. Therefore, the FBS had to offer significant improvement in each of these areas while remaining within a cost range acceptable to most fire departments. The program was conducted in five phases: concept definition, design, development, regulatory agency approvals, and field evaluation. Each of these phases is discussed in detail in the following sections.

Concept Definition

FBS concept selection.- A systems engineering approach was used to select the optimum system concept for the FBS. System-level requirements were generated with the overall objective of developing an improved FBS suitable for widespread fire department acceptance. Firefighters' needs were defined based on the operational considerations outlined by the User Requirements Committee. Physiological requirements of working firefighters were established by analysis of the user/FBS interface. These system-level requirements then become the criteria by which each candidate system concept was evaluated.

All self-contained breathing systems are in one of three broad categories: open-loop, closed-loop, or semi-closed-loop systems. The open-loop system, shown schematically in figure 2, consists of a breathing gas supply (usually compressed air), a control element, and a face mask. Breathing gas is supplied either continuously or in response to the wearer's inhalations; exhaled breath is discharged to the surroundings through a one-way valve in the face mask. This type of system is the one most commonly used by fire departments today. Advantages of the open-loop system include low initial and recharge costs, ease of maintenance, operability at low temperatures, and shutdown and restart capability.

The closed- and semi-closed-loop system concepts are illustrated in figure 3. The distinguishing characteristic of these systems is the recirculation of exhaled gas after removal of carbon dioxide and water vapor. Carbon

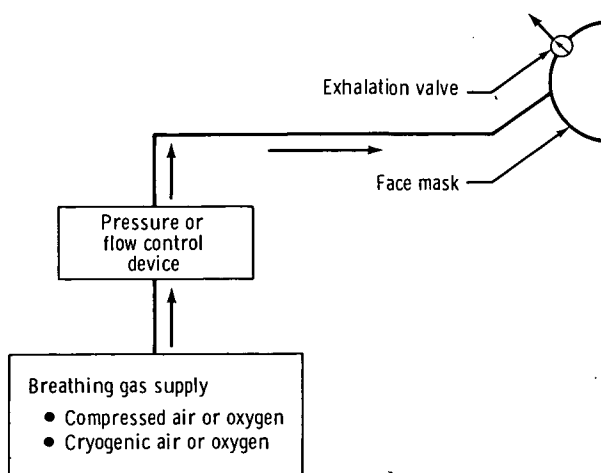

Figure 2.- Open-loop system schematic.

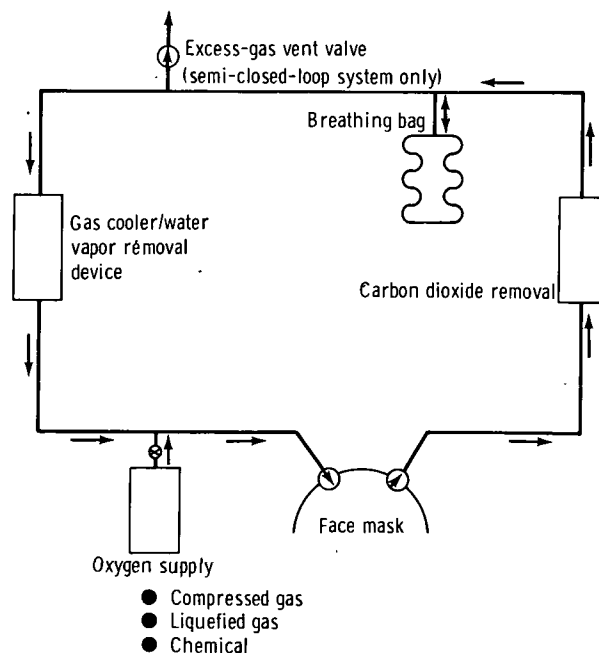

Figure 3.- Closed- and semi-closed-loop system schematic.

dioxide removal is accomplished by a chemical scrubber that absorbs carbon dioxide. Heat added to the gas stream must be removed by a gas cooler to avoid uncomfortably high inhalation temperatures. Moisture may be removed either by mechanical separation of condensate following gas cooling or by a desiccant canister. Oxygen is added to compensate for metabolic consumption by the user. The amount of oxygen added must be greater than or equal to the consumption at higher user activity levels. A system that supplies oxygen to exactly match user consumption with no vented excess is a closed-loop system, and one that supplies oxygen and vents the excess gas is a semi-closed-loop system. The oxygen supply may be compressed gas, liquefied gas, or a chemical. Several chemicals are available that combine carbon dioxide removal with oxygen generation functions. The advantages of a closed- or semi-closed-loop system are increased duration and minimum weight and bulk. The principal disadvantages are higher initial and recharge costs, the potentially hazardous use of pure oxygen, the potential buildup of toxic contaminants through mask leakage, decreased efficiency and actuation problems in low-temperature environments, some inability to restart after shutdown, complex maintenance and recharge procedures, and the lack of an acceptable depletion warning device.

Within the broad category of semi-closed-loop systems, there is a range of possible system designs that use a high percentage of makeup or purge flow to reduce the carbon dioxide and water vapor removal requirements and to provide partial cooling. The reduction in weight associated with cooling and contaminant removal does not offset the additional gas storage necessary for this type of system. The most attractive system of this type, sometimes referred to as a "partial rebreather," uses a small rebreathed volume combined with a high purge flow to eliminate the need for separate contaminant removal and cooling. This system is similar to the open-loop system except that a small accumulator (breathing bag) collects the initial exhaled breath, which is low in carbon dioxide, and supplies it at the beginning of the inhalation cycle, thus reducing the amount of gas drawn from the air supply. However, the air savings does not justify the added bulk and complexity of the partial rebreather over the less complex open-loop system.

Evaluation of the available concepts against system level requirements resulted in selection of the open-loop compressed air demand system. Although breathing systems of the closed- or semi-closed-loop types can provide longer operating duration and lower weight, most firefighting departments do not allow more than a 30-minute duration under heavy work conditions. The exhausting work of firefighting and the physiological limitations on metabolic heat storage in the body make longer durations impractical with state-of-the-art protective clothing and firefighting practices. The open-loop system can easily meet a 30-minute-duration requirement with acceptable weight.

Pressure vessel concept selection.- The pressure vessel represents the major portion of the weight and bulk of the open-loop system, and maximum user comfort is obtained when the weight of the pressure vessel is concentrated as near to the body as possible. A reduced profile is also desirable to improve maneuverability in tight quarters. A number of concepts were evaluated using single and multiple pressure vessel configurations, including chest, back, and hip mounted. Chest mounting was eliminated because of the requirements for firefighters to climb ladders, carry victims, and crawl on their stomachs.

The most desirable configuration consisted of several small cylindrical vessels distributed across the back; this concept was rejected, however, because of high cost and manifolding complexities. Therefore, the concept that was selected consisted of a single back-mounted cylindrical pressure vessel.

A high storage pressure results in a smaller size vessel for a given quantity of stored gas; however, because air becomes less compressible at high pressures, the size advantage diminishes with increasing pressure. The reduced compressibility of air also results in high vessel weight for a given quantity of stored gas. Consideration of these factors and of the availability of compressor systems for high-pressure recharge led to the selection of 27 600 kilopascals (4000 psig) as the optimum air storage pressure.

Depending on the size and physical conditioning of the user and on the task to be performed, a firefighter will deplete a 1.3 cubic meter (45 SCF) pressure vessel in approximately 20 minutes, giving a mean air-consumption rate of $0.064 \text{ m}^3/\text{min}$ (2.25 SCFM). Because the weight of the breathing system contributes to the workload of the wearer, particularly in climbing activities, it was assumed that a lighter system would result in a lower air-consumption rate. Lower breathing resistance and comfort of the unit also contribute to a general feeling of well-being, resulting in less psychological stress and reduced air consumption. Consideration of these factors led to the baseline usage rate of $0.057 \text{ m}^3/\text{min}$ (2 SCFM). Based on a design goal of 30 minutes' breathing duration under actual firefighting conditions, an air storage capacity of 1.7 cubic meters (60 SCF) was selected. Test results and field evaluation confirmed the validity of these assumptions.

A diversity of opinions was expressed by the user advisory panel regarding duration requirements for the FBS. Although members generally concurred that a 1.7-cubic meter (60 SCF) capacity (nominal 30-minute system) was desirable, some believed that a 20-minute nominal duration system was adequate for most firefighting applications and that a smaller, lighter 1.1-cubic meter (40 SCF) capacity system should be developed. Accordingly, the requirement for interchangeable 1.1- and 1.7-cubic meter (40 and 60 SCF) capacity vessels was established for the FBS.

Studies were conducted to define the optimum pressure vessel material and fabrication technique. Candidate materials that could provide a significant weight reduction over currently used steel cylinders included high-strength maraging steels, cryoformed and precipitation-hardening stainless steels, filament-wound composites, and titanium. Suitable criteria were applied to ensure that the selected material was strong enough to exhibit a leak before bursting under conditions of cyclic flaw growth. Other considerations included corrosion and impact resistance, formability, service life, and cost. Based on these factors, a trade-off of available materials and fabrication techniques was made, and a fiberglass-filament-overwrapped vessel with an aluminum load-sharing liner was selected.

Requirements definition.— System-level requirements developed during concept selection were expanded to include detailed environmental and performance requirements for the FBS and pressure vessels. These requirements

were detailed to the work statements released to potential contractors and are available in the applicable contractor final reports (refs. 1 to 3).

Vendor responsibilities.- Proposals were solicited and vendors were selected to conduct the detailed design, fabrication, and testing of the FBS based on the system-level requirements. Three separate contracts were awarded as follows:

Contract number	Vendor	Equipment
NAS 9-13177	Scott Aviation	FBS (excluding pressure vessels)
NAS 9-12540	Martin Marietta Corporation	1.2-cubic meter (42 SCF) vessel ¹
NAS 9-12414	Structural Composites Industries (SCI)	1.7-cubic meter (60 SCF) vessel

The original contracts required delivery of 33 pressure vessels of each configuration and 20 FBS units, including the qualification test unit. The contracts were later modified to include an additional fifty-five 1.2-cubic meters (42 SCF) pressure vessels as well as FBS spare components.

Design Phase

Detailed design of the FBS and the pressure vessels was based on the selected concepts and system requirements previously outlined. This section presents a description of the final FBS and pressure vessel designs.

FBS design.- The FBS with the 1.2-cubic meter (42 SCF) pressure vessel is illustrated in figure 4. The FBS harness (fig. 5) was designed so that most of the weight of the system is carried on the wearer's hips. This configuration reduces shoulder fatigue and removes weight from the spine. Pressure vessels are readily interchangeable on the fire scene through the use of a quick-release cylinder band clamp and a handtight pressure vessel high-pressure hose assembly interface. The 1.2- and 1.7-cubic meter (42 and 60 SCF) vessels are readily interchangeable because the band clamp has an adjustment for two sizes. The FBS has a two-stage regulator. The first (pressure reducing) stage is mounted on the back frame, and the second (demand) stage is mounted on the face mask. The chest area is left clear to avoid interference with the firefighter's movement. The demand regulator is easily detached from the face mask by actuating a release lever and rotating the regulator 90°.

¹The actual capacity of the Martin Marietta pressure vessel is 1.2 cubic meters (42 SCF), which slightly exceeds the initial 1.1-cubic meter (40 SCF) requirement.



Figure 4.- NASA FBS equipment.

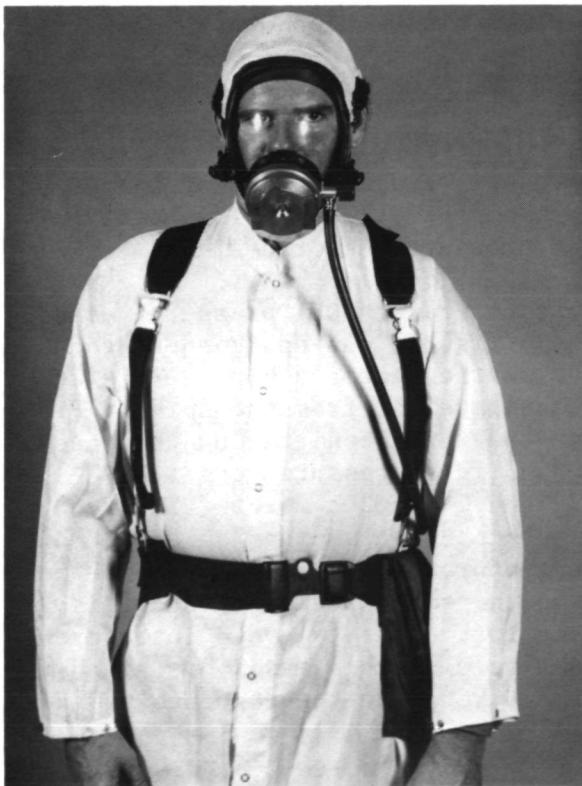

(a) Front view.



(b) Profile.

Figure 5. NASA FBS (donned).

With the demand regulator detached, the user can breathe through the large opening in the facepiece. The demand regulator is stowed in a pouch on the waistbelt.

The FBS face mask and demand regulator are illustrated in figure 6. A flexible bubble-type facepiece, held in place by a nylon net and a single adjustable strap, provides excellent visibility and face-mask to face sealing. This concept also offers a rapid donning capability and reduces the problem of helmet/mask interference. The small size, the thin flexible shell, and the restraint simplicity make the FBS mask considerably lighter than currently available face masks. The demand regulator incorporates a spray bar that channels the inlet flow over the visor during inhalation to eliminate visor fogging.

A flow schematic of the FBS is illustrated in figure 7. Breathing air stored in the pressure vessel flows through the cylinder valve, the frame-mounted pressure reducer assembly, the mask-mounted demand regulator, and into the mask. Each of these components is described in detail in the following paragraphs. Typical component weights for the FBS are summarized in table I.

Cylinder valve: The cylinder valve assembly provides an on/off control of gas flow. It contains a 0- to 31 000-kilopascal (0 to 4500 psig) pressure gage, a thermally sensitive rupture disk that relieves pressure at approximately 31 000 kilopascals (4500 psig) and 378 K (220° F), and a shock-absorbing bumper. The cylinder valve is connected to the pressure reducer by a flexible high-pressure hose with a modified Compressed Gas Association (CGA) number 1340 connector. The standard CGA connector was modified with a longer nipple to preclude connection of the FBS pressure vessel to a lower pressure system.

Pressure reducer: The frame-mounted pressure reducer assembly reduces cylinder pressure to an intermediate pressure of 550 to 625 kilopascals (80

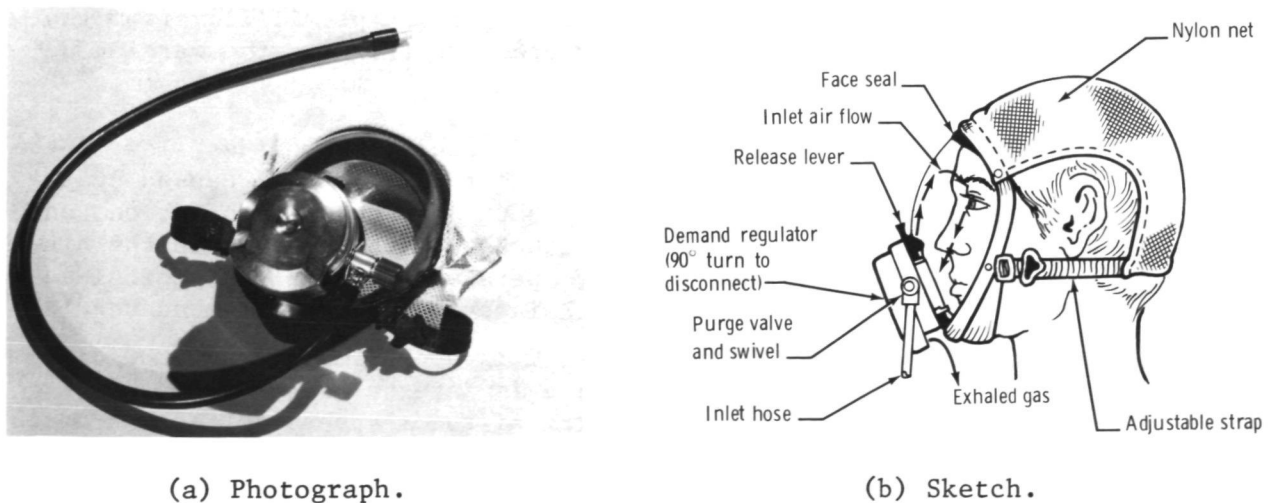

Figure 6.- NASA FBS face mask and demand regulator.

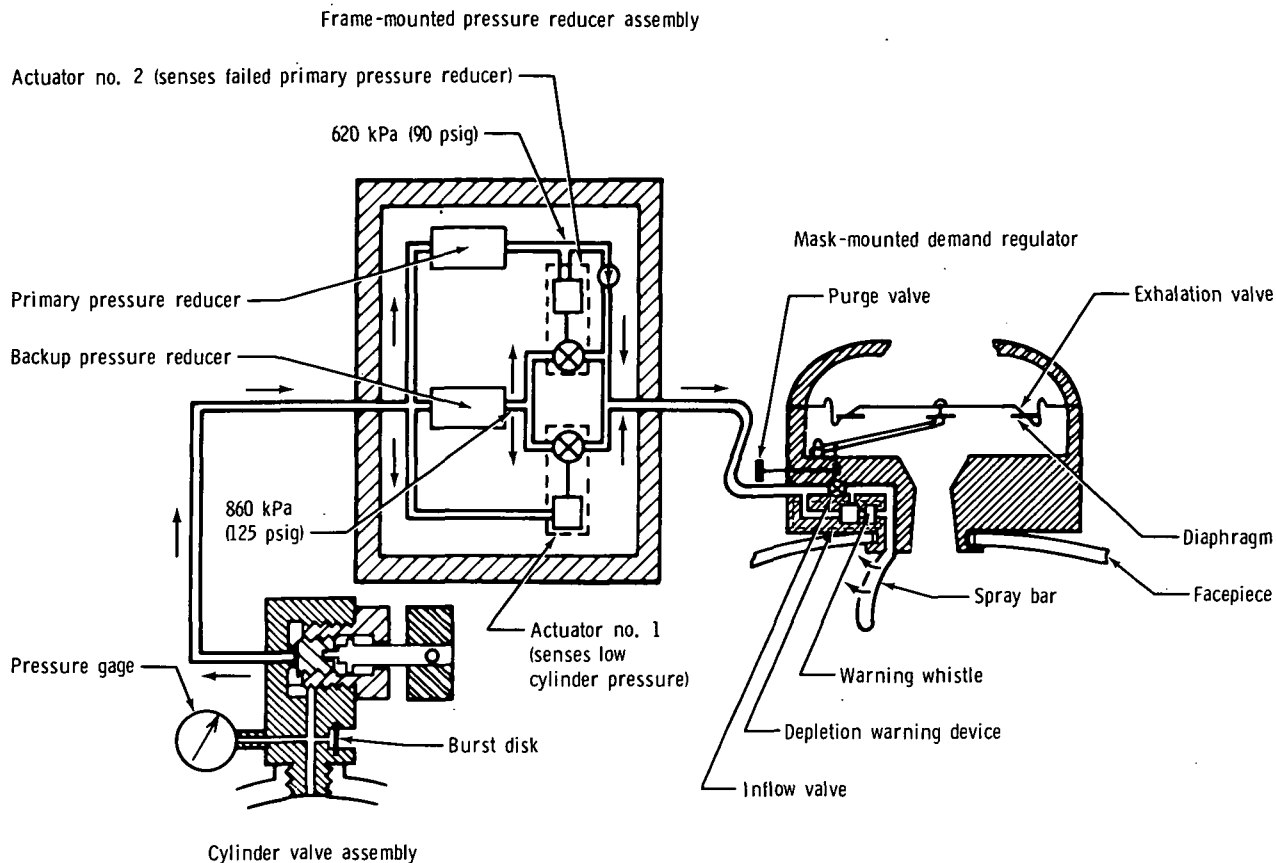

Figure 7.- NASA FBS schematic.

to 90 psig) in the normal or primary mode and 825 to 950 kilopascals (120 to 140 psig) in the secondary mode. Two automatic actuators control operation by selecting either the primary or secondary reducer output. Should the primary reducer fail or the cylinder pressure fall below 5850 kilopascals (850 psig), one of the actuators will automatically open and permit flow from the secondary reducer. The increased secondary pressure triggers the warning device in the demand regulator assembly.

Demand regulator: The mask-mounted demand regulator provides flow to the face mask upon sensing the negative demand pressure in the mask caused by the wearer's inhalation. The flow automatically shuts off during exhalation, and exhaled breath leaves the mask through the exhalation check valve in the diaphragm of the demand regulator. A manually operated purge valve is provided to allow the user to purge the mask of contaminants or, if the demand regulator fails, to provide bypass flow. Purge flow is approximately $150\,000\text{ cm}^3/\text{min}$ (150 SLPM). The depletion warning device is integral with the mask-mounted demand regulator. A pressure-sensing piston responds to the increased pressure when the pressure reducer transfers to secondary operation. Movement of this piston allows a small amount of airflow through the warning whistle, which sounds only during inhalation. The exhaust gas from the whistle is inhaled by the wearer, conserving the air supply.

TABLE I.- TYPICAL FBS COMPONENT WEIGHTS

Component	Weight, kg (lb)
Facepiece	0.24 (0.53)
Demand regulator	.28 (.63)
Frame and harness	1.8 (4.06)
Pressure reducer	1.2 (2.56)
1.2-m ³ (42 SCF) vessel and valve	4.3 (9.50)
1.7-m ³ (60 SCF) vessel and valve	6.3 (13.88)
Total 1.2-m ³ (42 SCF) system (empty)	7.9 (17.31)
Total 1.7-m ³ (60 SCF) system (empty)	9.8 (21.69)

Pressure vessel design.- The pressure vessel represents approximately 50 percent of the weight of the FBS and is thus a key component in the design. Table II outlines both the 1.2- and 1.7-cubic meter (42 and 60 SCF) pressure vessel designs. The designs are similar in that both use a seamless aluminum liner overwrapped with S-II-type fiberglass. After fabrication, vessels are subjected to a "sizing" pressurization. During sizing, the aluminum liner is stretched or yielded so that liner stresses during operation are reduced. Following sizing at zero pressure, the liner is in compression and the overwrap in tension. Table III shows the postsizing stresses for both vessels at various pressures.

Development Phase

FBS development.- The FBS was subjected to a rigorous series of design verification and qualification tests to demonstrate its ability to meet design requirements. All design goals were met, although the following minor changes to requirements were necessary.

1. During cold-temperature testing (222 K (-60° F)), the "push-to-test" function would not operate because of increased viscosity of the lubricant on the automatic transfer valve. No suitable alternative lubricant could be found, and the cold-temperature requirement for subsequent testing was adjusted to 233 K (-40° F).

TABLE II.- PRESSURE VESSEL DESIGN SUMMARY

Parameter	SCI 1.7-m ³ (60 SCF) vessel	Martin Marietta 1.2-m ³ (42 SCF) vessel	Comments
Length, cm (in.)	50.0 (19.7)	47.37 (18.65)	
Diameter, cm (in.) . . .	16.5 (6.5)	14.2 (5.6)	
Weight, kg (lb)			
Vessel and liner	5.8 (12.9)	3.9 (8.5)	
Liner	2.5 (5.5)	1.8 (3.9)	
Volume, cm ³ (in ³) . . .	6800 (415)	4687 (286)	1.7- and 1.2-m ³ (60 and 42 SCF) air capacity at 27 579 kPa (4000 psig).
Liner material	6351 T6 aluminum	6070 T6 aluminum	
Overwrap material	S-II fiberglass, 470 or 456 sizing (Owens Corning)	S-II fiberglass, 470 sizing (Owens Corning)	S-II is a commercial grade of S-type fiberglass.
Resin system	Dow DER-332, hexahydrophthalic anhydride (HHPA), and benzyldi- methylamine (BDMA)	Epon 828, Epon 1031, NADIC methyl anhydride (NMA), and BDMA	
Winding concept	Full overwrap, modified in-plane longitudinal and hoop	Full overwrap, helical longitudinal and hoop	Winding details are specified in Martin Marietta and SCI procedures.
Sizing pressure, kPa (psig)	46 540 (6750)	52 400 (7600)	Proof is 46 540 kPa (6750 psig).
Typical "new" burst pressure, kPa (psig)	89 600 to 96 500 (13 000 to 14 000)	89 600 to 96 500 (13 000 to 14 000)	

TABLE III.- PRESSURE VESSEL STRESSES - CYLINDRICAL SECTION

[All stresses in kPa (psig) at 297 K (75° F)]

Parameter	SCI vessel		Martin Marietta vessel	
	Hoop	Axial	Hoop	Axial
Liner stress at 27 600 kPa (4000 psig)	72 400 (10 500)	137 900 (20 000)	103 400 (15 000)	172 400 (25 000)
Filament stress at 27 600 kPa (4000 psig)	568 800 (82 500)	296 500 (43 000)	510 200 (74 000)	327 500 (47 500)
Residual liner stress at 0 kPa (0 psig) ^a	-241 300 (-35 000)	-83 000 (-12 000)	-195 800 (-28 400)	-51 700 (-7500)
Residual filament stress at 0 kPa (0 psia) ^b	265 450 (38 500)	152 400 (22 100)	233 000 (33 800)	172 400 (25 000)
Liner stress (required burst) at 62 000 kPa (9000 psig)	296 500 (43 000)	293 000 (42 500)	372 300 (54 000)	375 750 (54 500)
Filament stress (required burst) at 62 000 kPa (9000 psig)	1 137 650 (165 000)	696 400 (101 000)	980 450 (142 200)	761 900 (110 500)
Liner stress (proof) at 46 540 kPa (6750 psig) ^c	289 600 (42 000)	289 600 (42 000)	303 400 (44 000)	318 550 (46 200)
Filament stress (proof) at 46 540 kPa (6750 psig)	779 100 (113 000)	396 450 (57 000)	708 100 (102 700)	430 900 (62 500)

^aLiner is in compression following sizing.

^bWinding is in tension following sizing.

^cSCI vessel, 100 percent of yield; Martin Marietta vessel, 87 percent of yield.

2. During impact testing, the high-pressure-valve outlet fitting was cracked when dropped 1.8 meters (6 feet) onto the outlet connector. The valve outlet fitting was redesigned to have a stainless steel nipple (instead of aluminum) in the modified CGA 1340 connector for added strength. The valve manufacturing procedure was also modified to change the orientation of the metal grain structure for added strength in the direction of failure. Drop tests were successfully conducted following these modifications.

3. During 366-K (200° F) thermal exposure testing, the pressure vessel relief device actuated because of increased vessel pressure and softening of the fusible alloy; also, the high temperature caused rapid degradation of the Kel-F pressure reducer seats. The maximum operating temperature requirement was modified to 347 K (165° F) for subsequent testing. High-temperature exposure of the FBS is most likely to occur during storage on the firetrucks or during shipment. Although temperatures at the fire scene may be considerably higher than 366 K (200° F), the FBS temperature remains low because of its thermal mass and internal gas flow.

Following qualification testing, a series of manned treadmill tests was conducted at NASA to provide additional confidence and duration data. Manned tests were also conducted using several commercially available breathing systems for comparison with the FBS. These tests confirmed that the lighter weight of the FBS results in a lower gas-consumption rate. Tests results are summarized in table IV.

The next phase of FBS testing was conducted at the Houston Fire Training Academy (HFTA). Tests were designed to provide operational experience using fire department trainees as subjects. A series of test runs was made in the training tower and smokehouse. Half the team wore the NASA FBS and half used existing commercial units. Table V summarizes the results of all HFTA testing and further confirms the lower gas-consumption rates experienced by the FBS users.

During the first series of HFTA tests (June 24 and 26, 1974), the depletion warning whistle failed to actuate on two of the three FBS units during a smokehouse run. Failure analysis showed that the pressure reducer seats had deformed. The deformation caused a downward shift in the secondary outlet pressure that was insufficient to trigger the warning whistle. Pressure reducer seats were redesigned to preclude this deformation.

The diaphragm actuator for the pressure reducer was also replaced by a piston to provide better stem guiding of the stem into the seat. A spring change was also made to lower the primary outlet pressure and raise the secondary pressure for more reliable warning tone operation. It was found that the redesigned pressure reducer could not provide the desired $476\ 000\ \text{cm}^3/\text{min}$ (476 SLPM) primary flow at minimum cylinder pressure. The primary flow requirement was reduced to $390\ 000\ \text{cm}^3/\text{min}$ (390 SLPM) at minimum pressure conditions.

TABLE IV.- RESULTS OF NASA MANNED FBS TESTING^a

[Dec. 6, 1973, through Jan. 28, 1974]

System	System capacity, m ³ (SCF)	System weight, kg (lb)	Duration for test subjects, min (b)			Average air consumption rate, m ³ /min (SCFM)
			Subject A	Subject B	Subject C	
NASA FBS	1.2 (42)	9 (20)	33.6	42.9	38.9	0.031 (1.09)
NASA FBS	1.7 (60)	12 (26)	45.2	53	65.9	.032 (1.12)
Commercial	1.3 (45)	15 (33)	35.8	41.2	31.3	.036 (1.26)
Commercial	1.7 (60)	19 (41)	40.3	53.6	44.8	.037 (1.32)
Commercial	2.0 (72)	20 (43)	41.5	63.3	55.3	.039 (1.39)

^aTest conditions:

1. All subjects had at least one previous treadmill run.
2. Treadmill speed was 1.6 m/sec (3.5 mph) with a 3° slope.

^bTest subject data:

<u>Subject</u>	<u>Height, m (ft)</u>	<u>Weight, kg (lb)</u>	<u>Age, yr</u>
A	1.80 (5.9)	83 (184)	48
B	1.77 (5.8)	71 (156)	36
C	1.83 (6.0)	63 (139)	37

TABLE V.- SUMMARY OF HFTA TEST RESULTS

System	Average air consumption rate, m ³ /min (SCFM)	No. of data points
FBS (1.2 m ³ (42 SCF))	0.056 (1.99)	15
FBS (1.7 m ³ (60 SCF))	.050 (1.77)	6
Commercial (1.3 m ³ (45 SCF))	.064 (2.27)	20

During the seat redesign phase, changes were also made to the pressure reducer check valve and transfer valve to improve low-temperature operation and to make the "push-to-test" function work more smoothly. Following additional qualification testing (which included high- and low-temperature exposure at high pressure and life cycling), these modifications were retrofitted into all FBS units. Each unit was acceptance tested at Scott Aviation and again at JSC before being released for field evaluation. Representative performance data are outlined in table VI.

The HFTA tests were repeated on September 16 and 17, 1974, with no further difficulties. Following an NASA in-house review of all design and test data, the FBS was considered ready for release to selected cities for field evaluation testing.

Pressure vessel development.- Pressure vessel development proceeded concurrently at the Martin Marietta Corporation and at SCI beginning in January 1972. Vessels were fabricated for burst and cycle testing to verify the design stress levels. During the development phase, the original Martin Marietta design was changed from E-type glass to S-type glass to reduce weight, and adjustments were made in axial fiber stress levels. Following design verification, all qualification and deliverable vessels were fabricated. Test vessels were randomly selected and subjected to a series of qualification tests.

Martin Marietta vessels: Qualification tests of the Martin Marietta vessels, as outlined in table VII, showed excellent vessel performance with the exception of vessel serial number (S/N) 14 (test 3), which failed in a hot water bath during thermal cycling. Failure analysis revealed that this vessel had been prematurely removed from the manufacturing cycle and had not been exposed to the epoxy cure cycle. Uncured resin has very low strength and poor moisture, chemical, and thermal resistance. Failure of this vessel emphasized the necessity for rigid quality control during the manufacturing process. Additional quality control procedures were instituted, including a requirement for the inspector's stamp to be displayed on each vessel.

TABLE VI.- TYPICAL PERFORMANCE DATA

Primary pressures at 8300-kPa (1200 psig) cylinder, kPa (psig):

Inhalation	483 (70)
Exhalation	586 (85)
Lockup	607 (88)

Secondary pressures at 8300-kPa (1200 psig) cylinder, kPa (psig):

Inhalation	862 (125)
Exhalation	965 (140)
Lockup	979 (142)

Secondary pressures at 2070-kPa (300 psig) cylinder, kPa (psig):

Inhalation	827 (120)
Exhalation	931 (135)
Lockup	945 (137)

Whistle alarm pressures, kPa (psig):

Full on	745 (108)
Full off	552 (80)

Inhalation cracking pressures, Pa (in. H₂O) 99.6 (0.4)

Exhalation cracking pressure, Pa (in. H₂O) 12.45 (0.05)

Low-pressure transfer, kPa (psig) 6030 (875)

Maximum flows at 311.36 Pa (1.25 in. H₂O) demand pressure, cm³/min (SLPM):

Primary at 8300 kPa (1200 psig)	400 000 (400)
Secondary at 3930 kPa (570 psig)	560 000 (560)
Secondary at 689 kPa (100 psig)	190 000 (190)

Exhalation flow at 249.09 Pa (1 in. H₂O),
cm³/min (SLPM) 250 000 (250)

Purge flow (full on), cm³/min (SLPM) 150 000 (150)

Mask and demand regulator leakage (measured on
manikin head), cm³ 10

TABLE VII.- MARTIN MARIETTA QUALIFICATION TESTING

Test No.	Test	Results	Comments
1	Single cycle burst	88 300-kPa (12 800 psig) burst pressure	
2	Deleted		Unit 2 was committed to a partial qualification sequence (test 7) after failure of unit 3.
3	Full qualification sequence Pressure cycling (room temperature) 3-m (10 ft) drop test: six drops at 222 K (-60° F) and six drops at 366 K (200° F) Thermal cycling from 222 to 366 K (-60° to 200° F)	Failure at approximately 34 500 kPa (5000 psig) during the third thermal cycle	Failure analysis revealed that test unit 3 had not been exposed to the cure cycle because it was prematurely removed from the manufacturing sequence.
4	Gunfire	No tearing or fragmentation	
5	Flaw growth (1000 operating cycles with an intentional flaw in the wrap)	No flaw growth; subsequent burst pressure was 84 100 kPa (12 200 psig); failure in dome, not at flaw	Intentional flaw was cut to 50 percent of the wrap thickness and 2.5 cm (1 in.) long.
6	Pressure cycling (10 000 operating cycles and 30 proof cycles)	Subsequent burst at 88 600 kPa (12 850 psig)	Unit was cycled at SCI with SCI unit 6B. Test 6 was added to get additional cycling data on the Martin Marietta vessel. Pressure cycling 0 to 27 600 kPa (0 to 4000 psi) (operating) and 0 to 46 540 kPa (0 to 6750 psi) (proof).
7	Partial qualification sequence Pressure cycling (10 000 operating cycles and 100 proof cycles) Three 3-m (10 ft) drops at 294 K (70° F) Thermal cycling from 222 to 355 K (-60° to 180° F) (three cycles by bath immersion) 10 operating pressure cycles High-temperature exposure (589 K (600° F) for 5 min)	Subsequent burst at 88 300 kPa (12 800 psig)	Test 7 was added to determine the effect of a test sequence less severe than the full qualification sequence.
8	Drop test: 5-m (16 ft) drop with 90 kg (200 lb) attached, five times at 31 000 kPa (4500 psi)	Subsequent burst at 69 600 kPa (10 100 psig)	Test 8 was added to replace the drop test deleted in test 2.
9	Full qualification sequence Pressure cycling (10 000 operating cycles and 100 proof cycles) 3-m (10 ft) drop test Thermal cycling from 222 to 366 K (-60° to 200° F) (20 times by bath immersion) High-temperature exposure (589 K (600° F) for 5 min)	Subsequent burst at 69 000 kPa (10 000 psig)	Unit was added to demonstrate full qualification sequence. The drop test consisted of six drops at 366 K (200° F) while pressurized to 27 600 kPa (4000 psig). The 69 000-kPa (10 000 psig) burst pressure exceeded the 62 000-kPa (9000 psig) minimum requirement following qualification sequence.

Two additional lots of Martin Marietta vessels were fabricated. These were wound at the Martin Marietta facility in Denver (the previous group had been wound under a subcontract to Advanced Composites in Salt Lake City, Utah). Additional cycle and burst tests were conducted on these vessels to verify performance. The slightly low burst pressure of vessel S/N 3-7 required improvements in the winding procedure to provide additional hoop fiberglass reinforcement of the end domes. All the vessels of the final group (4- series) were wound using the improved technique.

To ensure that the highest quality vessels were used in the field evaluation program, all the vessels of the original group were used in the long-term test program at the NASA Lewis Research Center (LeRC), and only the final group of vessels (4- series) was used in the field evaluation. Twenty vessels of the final group that had previously been delivered to LeRC for long-term testing were returned to JSC for field evaluation. Table VIII shows the cycling and long-term pressurization testing conducted on these vessels at LeRC before they were returned for field evaluation testing.

SCI vessels: The results of the SCI qualification testing are summarized in table IX. The only significant problem occurred during test 6A when vessel S/N 12 developed a leak in the liner after 6633 operating pressure cycles and 18 proof cycles. Failure analysis of this vessel showed a typical cyclic flaw growth condition and indicated that liner stresses were higher than expected. Increased liner stress was probably caused by relaxation of the overwrap during the 590 K (600° F) exposure test. Additional cycling tests were performed without failures.

As with the Martin Marietta vessels, improvements were made to the SCI winding procedure. Some of the early vessels (including several qualification test vessels) showed slight imperfections, apparently caused by delaminations within the overwrap. Although no performance degradation could be attributed to these imperfections, several vessels were rejected during manufacturing inspection for this condition. Details of the development and testing of FBS pressure vessels are given in references 2 and 3.

Additional pressure vessel testing: A total of 22 Martin Marietta and 2 SCI vessels was delivered to LeRC for long-term testing. During this 10-year test program, vessels are pressurized and exposed to an outdoor weathering environment with intermittent pressure cycling. Burst tests are conducted periodically to determine the effects of long-term exposure. The first vessel burst test was conducted on March 31, 1975, on Martin Marietta vessel S/N 8 after 370 days of exposure testing at a pressure of 27 600 to 31 000 kilopascals (4000 to 4500 psig). The burst pressure of this vessel was 69 000 kilopascals (10 000 psig).

Several SCI vessels delivered to NASA showed evidence of slight wrap imperfections as previously discussed. To provide additional confidence that this condition would not affect vessel performance, SCI vessel S/N 42 was sent to LeRC for cycle burst testing. The burst pressure of this vessel was approximately 83 000 kilopascals (12 000 psig) after 1000 pressurization cycles to 29 300 kilopascals (4250 psig).

TABLE VIII.- PRESSURIZATION HISTORY OF VESSELS RETURNED FROM LEWIS RESEARCH CENTER

Martin Marietta vessel serial no.	Sustained pressure, kPa (psig)	Total time under pressure, hr	Cycling pressure	No. of copies
4-3	27 600 to 31 000 (4000 to 4500)	1805.8	NA ^a	0
4-11	27 600 to 31 000 (4000 to 4500)	1805.8	NA	0
4-12	27 600 to 31 000 (4000 to 4500)	1805.8	NA	0
4-16	27 600 to 31 000 (4000 to 4500)	1805.8	NA	0
4-39	27 600 to 31 000 (4000 to 4500)	1805.8	NA	0
4-22	27 600 to 31 000 (4000 to 4500)	2074.9	NA	0
4-23	27 600 to 31 000 (4000 to 4500)	2074.9	NA	0
4-32	27 600 to 31 000 (4000 to 4500)	2074.9	NA	0
4-33	27 600 to 31 000 (4000 to 4500)	2074.9	NA	0
4-42	27 600 to 31 000 (4000 to 4500)	2074.9	NA	0
4-7	27 600 to 31 000 (4000 to 4500)	2090.0	NA	0
4-14	27 600 to 31 000 (4000 to 4500)	2090.0	NA	0
4-20	27 600 to 31 000 (4000 to 4500)	2090.0	NA	0
4-31	27 600 to 31 000 (4000 to 4500)	2090.0	NA	0
4-6	27 600 to 31 000 (4000 to 4500)	1559.0	NA	1000 ± 5
4-30	27 600 to 31 000 (4000 to 4500)	1559.0	NA	1000 ± 5
4-37	27 600 to 31 000 (4000 to 4500)	1559.0	NA	1000 ± 5
4-40	27 600 to 31 000 (4000 to 4500)	1559.0	NA	1000 ± 5
4-45	27 600 to 31 000 (4000 to 4500)	1559.0	NA	1000 ± 5
4-10	27 600 to 31 000 (4000 to 4500)	4441.0	NA	0

^aNot applicable.

TABLE IX.- SCI QUALIFICATION TESTING

Test no.	Test	Results	Comments
1	Gunfire	No fragmentation; 1.90-cm (0.75 in.) liner tear; vessel retained slug	
2	Drop test: 5-m (16 ft) drop with 90-kg (200 lb) load onto rigid steel plate, five times at 31 000 kPa (4500 psig)	Subsequent burst at 64 100 kPa (9300 psig)	Unit has surface damage caused by "pin-wheeling" around test cell after test fitting failure.
3	Pressure cycling, high/low temperature: 5000 operating cycles at 222 K (-60° F) 5000 operating cycles at 366 K (200° F) 100 proof cycles at 294 K (70° F)	Subsequent burst at 57 200 kPa (8300 psig)	Test does not reflect actual conditions and should be considered as an off-design test for information only. Pressure cycling from 0 to 27 600 kPa (0 to 4000 psig) (operating) and 0 to 46 540 kPa, (0 to 6750 psig) (proof).
4	Flaw growth, wrap (1300 pneumatic cycles with intentional flaw in wrap)	No flaw growth; ultimate failure at 21 400 kPa (3100 psig) after 10-cm (4 in.) cut was introduced through hoop wrap	The wrap was initially cut to 50 percent of the hoop wrap depth by 2.5 cm (1 in.) long. No flaw growth occurred in the wrap after 1000 cycles to 27 600 kPa (4000 psi); flaw size was increased three times following 100 pressurization cycles until failure occurred.
5	Flaw growth, liner (1000 pneumatic cycles with intentional flaw in liner)	No failure during cycling; subsequent liner leak failure at 58 250 kPa (8450 psig) during pneumatic burst test	Intentional liner flaw was 0.015 cm (0.006 in.) deep by 0.07 cm (0.030 in.) long.
6	3-m (10 ft) drop test, high/low temperature: six drops at 222 K (-60° F) and six drops at 366 K (200° F)	Subsequent burst at 68 250 kPa (9900 psig)	Unit was scheduled for full qualification sequence but outer wrap was severely damaged following failure of the test fitting. Unit was pressurized to 24 100 kPa (3500 psig) for the 222 K (-60° F) drop, and to 31 000 kPa (4500 psig) for the 366-K (200° F) drop. The orientations were equally distributed between each end and each side.
6A	Full qualification sequence High-temperature exposure (589 K (600° F) for 5 min) Thermal cycling from 222 to 366 K (-60° to 200° F) (20 times by bath immersion) Salt-fog exposure	Liner leak after 6633 operating and 18 proof cycles	Unit 6A was added to replace unit 6.
6B	Full qualification sequence Pressure cycling (10 000 operating cycles and 30 proof cycles) Thermal cycling from 222 to 366 K (-60° to 200° F) (20 times by bath immersion) 3-m (10 ft) drop test High-temperature exposure (589 K (600° F) for 5 min)	Subsequent burst at 84 800 kPa (12 300 psig)	Unit 6B was added to replace unit 6A. Proof cycle requirement was reduced from 100 to 30. High-temperature test was moved to be last in sequence. Salt-fog exposure was deleted and underwater cycling was added on a subsequent test. The 84 800-kPa (12 300 psig) burst pressure exceeded the 62 000-kPa (9000 psig) minimum requirement following qualification sequence.
7	Pressure cycling (underwater; 10 000 operating cycles and 100 proof cycles)	Subsequent burst at 66 200 kPa (9600 psig)	Test was added to demonstrate water exposure capability.

TABLE IX.- Concluded

Test no.	Test	Results	Comments
8	Thermal exposure 12 exposures (478 K (400° F) for 10 min)	Subsequent burst at 91 000 kPa (13 200 psig)	Test was added to further demonstrate high-temperature exposure capability.
9	Pressure cycling: 10 000 operating cycles to 31 000 kPa (4500 psig) and 30 proof cycles to 51 700 kPa (7500 psig)	Subsequent burst at 62 000 kPa (9000 psig) (liner leak failure)	Tests 9 and 10 were added as lot verifi- cation following change in fiberglass sizing by Owens Corning. Increased cycling pressure (31 000 kPa (4500 psig)) was also demonstrated.
10	Single cycle burst	Burst at 93 800 kPa (13 600 psig)	

Martin Marietta vessel S/N 4-60 was also sent to LeRC for burst testing after approximately 5 months of use in the field evaluation program in New York City. A burst pressure of 91 700 kilopascals (13 300 psig) indicated that no significant degradation had occurred.

After completion of the field evaluation program, eight vessels (four Martin Marietta and four SCI) were selected from those used in New York and Los Angeles and were burst or cycled and burst tested. The results of this testing are shown in table X. It should be noted that two of the Martin Marietta vessels (S/N 4-6 and S/N 4-37) had been exposed to cycling and sustained pressurization at LeRC before field evaluation (table VIII).

Regulatory Agency Approvals

A prime objective of the FBS program was the development of a system that could be readily commercialized. To help ensure commercial acceptance, it was decided that regulatory agency approvals should be obtained for the FBS prototypes and pressure vessels. Two governmental regulatory agencies are involved with approval of compressed-air breathing equipment. The Department of Transportation (DOT) approves pressure vessels for interstate transportation, and the National Institute of Occupational Safety and Health (NIOSH) approves breathing equipment.

A prerequisite for the DOT permit is approval of the pressure relief device on the pressure vessel by the Association of American Railroads, Bureau of Explosives. The FBS cylinder valve incorporates a combination frangible burst disk backed up by a fusible-alloy temperature-sensitive plug. A temperature of approximately 378 K (220° F) combined with a pressure of 31 000 kilopascals (4500 psig) in the vessel will safely relieve pressure. Flame tests were conducted at the NASA White Sands Test Facility and witnessed by an inspector from the Bureau of Explosives. The flame test requires igniting a wood and kerosene fire under a fully charged vessel. Two Martin Marietta vessels were tested as shown in figure 8. Pressures and temperatures were recorded as shown in table XI. Both vessels safely relieved pressure as required. A copy of the approval issued by the Bureau of Explosives is shown

TABLE X.- POST-FIELD-EVALUATION BURST TESTS

Vessel serial no.	Operating pressure cycles, (excluding field evaluation) ^a	Burst pressure, kPa (psig)
4-33 (Martin Marietta)	0	91 000 (13 200)
4-20 (Martin Marietta)	^b 9000	^c 73 800 (10 700)
4-37 (Martin Marietta)	1000	91 700 (13 300)
4-6 (Martin Marietta)	10 000	90 300 (13 100)
71 (SCI)	0	97 200 (14 100)
56 (SCI)	0	95 800 (13 900)
57 (SCI)	10 000	86 200 (12 500)
72 (SCI)	10 000	96 875 (14 050)

^aAs many as 50 additional pressure cycles were applied during field evaluation.

^bIt was intended that S/N 4-37 receive 9000 cycles before burst, making a total of 10 000 cycles; however, S/N 4-20 was cycled inadvertently. See table VII for vessel pressurization history.

^cThe burst pressure is acceptable but below the average of other vessels. Failure apparently initiated in fatigue cracks resulting from forming folds near the valve end of the vessel.

in appendix A. Application was made to the DOT, and Special Permit No. 6747 was issued to allow shipment of charged FBS cylinders. A copy of the special permit (second yearly revision) is shown in appendix B.

Two FBS units were submitted for testing in accordance with NIOSH requirements as specified in the Federal Register, Volume 37, Number 59, Part II. Following is a summary of NIOSH test requirements.

1. Weight not to exceed 16 kilograms (35 pounds).
2. Inhalation resistance not to exceed 311.36 pascals (1.25 inches H₂O) at 120 000 cm³/min (120 SLPM).
3. Exhalation resistance not to exceed 249 pascals (1 inch H₂O) at 85 000 cm³/min (85 SLPM).

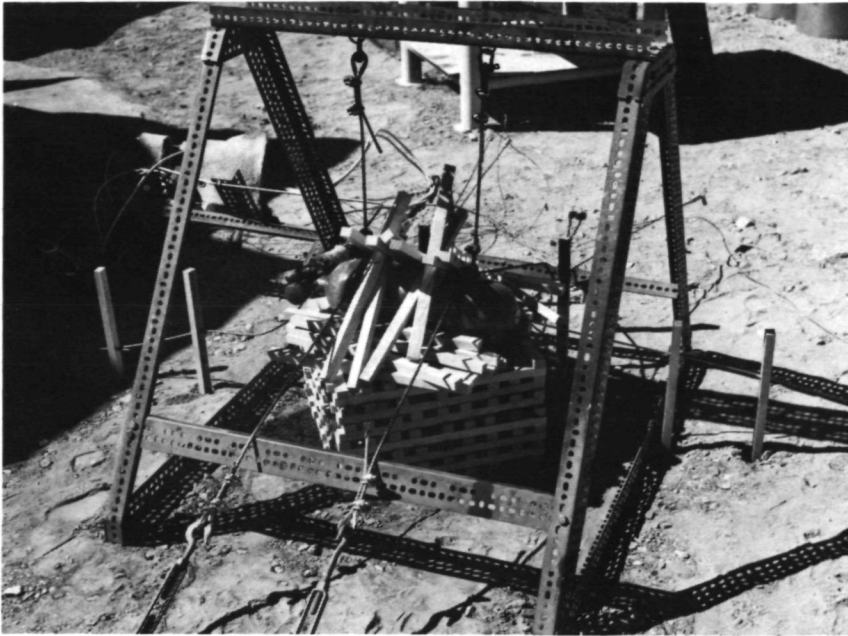

Figure 8.- Flame test setup.

TABLE XI.- FLAME TEST PRESSURE AND TEMPERATURE

Parameter	Vessel 1	Vessel 2
Relief pressure, kPa (psig)	30 685 (4450)	30 370 (4405)
Valve area temperature, K (°F)	802 (983)	593 (608)
Time until depressurization, min	2	3.5
Bottle S/N	60	79

4. Dry exhalation valve leakage not to exceed $30 \text{ cm}^3/\text{min}$ at 249 pascals (1 inch H_2O) suction.

5. Airflow to exceed $200\,000 \text{ cm}^3/\text{min}$ (200 SLPM) at 498 pascals (2 inches H_2O) demand pressure and 3450 kilopascals (500 psig) cylinder pressure.

6. Service time to determine approved duration. Test conducted at $40\,000 \text{ cm}^3/\text{min}$ (40 SLPM) and 24 respirations/min.

7. Average inspired carbon dioxide not to exceed 2.5 percent. Test conducted at $10\,500 \text{ cm}^3/\text{min}$ (10.5 SLPM) and 14.5 respirations/min. Exhaled carbon dioxide concentration is 5 percent.

PERMISSIBLE

ONE-HALF HOUR
SELF-CONTAINED DEMAND-TYPE COMPRESSED-AIR
BREATHING APPARATUS FOR FIRE FIGHTING

Federal Aviation Administration of the Interior
mesa
Mineral Resources and Safety Administration

U.S. Department of Health, Education, and Welfare
Center for Disease Control
NIOSH
National Institute for Occupational Safety and Health

MINING ENFORCEMENT AND SAFETY ADMINISTRATION
NATIONAL INSTITUTE FOR OCCUPATIONAL
SAFETY AND HEALTH

APPROVAL NO. TC-137-50

ISSUED TO
NATIONAL AERONAUTICS AND SPACE ADMINISTRATION
Houston, Texas, U. S. A.

The approved assembly consists of the following part numbers: 27234-00 facepiece assembly; 27240-00 frame and harness assembly; 27235-00 regulator assembly; 27237-00 pressure reducer assembly; and 1630-72-14 cylinder assembly. This approval applies only to the above assemblies with serial numbers 1 through 26, inclusive.

LIMITATIONS

Approved for respiratory protection during fire fighting, at temperatures above -25°F. Approved only when compressed air container is fully charged with air, meeting the requirements of the Compressed Gas Association, G-7. One for Type 1, Grade D air, or equivalent specifications. The container shall be marked "Charge With Air Only", and shall meet applicable DOT specifications. This approval is valid only during the National Aeronautics and Space Administration Evaluation Period.

CAUTION

Use with adequate skin protection when worn in gases or vapors that poison by skin absorption (e.g., hydrocyanic acid gas). The respirator, during this evaluation period, shall be selected, fitted, used, and maintained in accordance with applicable regulations.

PERMISSIBLE

FORTY-FIVE MINUTE
SELF-CONTAINED DEMAND-TYPE COMPRESSED-AIR
BREATHING APPARATUS FOR FIRE FIGHTING

Federal Aviation Administration of the Interior
mesa
Mineral Resources and Safety Administration

U.S. Department of Health, Education, and Welfare
Center for Disease Control
NIOSH
National Institute for Occupational Safety and Health

MINING ENFORCEMENT AND SAFETY ADMINISTRATION
NATIONAL INSTITUTE FOR OCCUPATIONAL
SAFETY AND HEALTH

APPROVAL NO. TC-137-51

ISSUED TO
NATIONAL AERONAUTICS AND SPACE ADMINISTRATION
Houston, Texas, U. S. A.

The approved assembly consists of the following part numbers: 27234-00 facepiece assembly; 27240-00 frame and harness assembly; 27235-00 regulator assembly; 27237-00 pressure reducer assembly; and 1269367-1 cylinder assembly. This approval applies only to the above assemblies with serial numbers 1 through 26, inclusive.

LIMITATIONS

Approved for respiratory protection during fire fighting, at temperatures above -25°F. Approved only when compressed air container is fully charged with air, meeting the requirements of the Compressed Gas Association, G-7. One for Type 1, Grade D air, or equivalent specifications. The container shall be marked "Charge With Air Only", and shall meet applicable DOT specifications. This approval is valid only during the National Aeronautics and Space Administration Evaluation Period.

CAUTION

Use with adequate skin protection when worn in gases or vapors that poison by skin absorption (e.g., hydrocyanic acid gas). The respirator, during this evaluation period, shall be selected, fitted, used, and maintained in accordance with applicable regulations.

Figure 9.- NIOSH approvals.

8. Cold-temperature manned tests at the temperature to which the unit is to be certified. (The FBS tests were run at 242 K (-25° F).)
9. Manned room-temperature tests using specified work profiles.
10. Gas tightness (mask leakage) to be tested by six persons for 2 minutes each in an atmosphere of 1000 p/m isoamyl acetate. No order or taste detectable.

The NIOSH approvals were obtained and are shown in figure 9. The FBS was approved for 30 minutes' duration with the 1.2-cubic meter (42 SCF) pressure vessel and for 45 minutes with the 1.7 cubic meter (60 SCF) pressure vessel. The FBS S/N 13 was retained by NIOSH as a record unit.

Field Evaluation

Early in the program, it was determined that a field evaluation phase would be required to fully evaluate the FBS. The value of the field evaluation program in detecting problem areas has been repeatedly demonstrated in that problems which do not occur during extensive development and qualification testing can be detected during actual usage. Consequently, a rigorous field evaluation plan was developed that would expose the FBS to a variety of conditions.

Objectives.- Field evaluation of the FBS began in late 1974 and was terminated in the fall of 1975. The primary objectives of the field evaluation phase were to verify the FBS performance through heavy usage under actual firefighting conditions and to define significant performance deficiencies and possible improvements. By isolating and correcting these deficiencies during the prototype or limited-production phase of the FBS development, costly production errors could be eliminated. An additional objective was to demonstrate that an improved FBS can result in more efficient firefighting. The fire service would also become acquainted with the improved system, which would aid their future procurement of breathing apparatus.

Evaluation sites.- The FBS field evaluation sites were mutually agreed on by the User Requirements Committee and NASA. A variety of factors, including geographic location, availability of charging equipment, and workload, were considered in the site selection. The following field evaluation sites were chosen.

1. Houston Fire Department (HFD) (Engine Companies 16 and 28)
2. Fire Department of New York (FDNY) (Ladder Company 19 and Squad Company 4)
3. Los Angeles City Fire Department (LACFD) (Task Force 27)

These companies handle a multitude of different firefighting situations from single-family frame dwellings to 19th-century tenements to modern high-rise apartments; from light industry to industrial parks; from single-story commercial buildings to regional shopping centers; and all ages, shapes, and sizes of schools, hospitals, hotels, motels, and nursing homes. Weather conditions range from subfreezing to subtropical, and workloads range from moderate to extremely heavy. Detailed descriptions and other information about these companies are contained in appendix C.

During the period of evaluation in Houston, Engine Company 16 made 577 responses, 70 of which were to structural fires. Engine Company 28 responded to 502 alarms, 96 of which were for structural fires.

In New York, Ladder Company 19 made 2372 responses, 605 of which were to structural fires. Of those 605 structural fires, 232 were "all hands" (full first-alarm assignment), 30 were second alarms, 10 were third alarms, and 5 were fourth alarms. During the same time period, Squad Company 4 responded

to 2819 alarms, 430 of which were structural fires (200 as a squad and 230 as an engine company). Of those 430 structural fires, 157 were "all hands," 38 were second alarms, and 5 were third alarms.

Task Force 27 in Los Angeles made 520 responses as a task force; an additional 388 responses were made by Engine Company 227 responding alone. Of these responses, the task force operated at 121 structural fires, 6 of which were multiple alarms.

Support equipment.- Several pieces of support equipment were required to conduct the field evaluations. These included FBS mounting brackets, compressed-air charging equipment, and performance verification test stands. Descriptions and schematics of this equipment are contained in appendix D.

Documentation of field usage.- Training sessions were conducted at all field evaluation sites to familiarize potential users with the FBS and associated equipment. After the personnel at each evaluation site demonstrated their proficiency in using the hardware and all installations were completed, the hardware was released for field use. Each field evaluation city and JSC entered into an agreement covering the handling of, and responsibilities for, the hardware during the evaluation phase. To ensure that the data from the field evaluation were representative, approximately 6 months of use time was accumulated at each location. A reporting system was established whereby a form was completed by the user and forwarded to JSC for each usage of an FBS under actual fire conditions.

In addition to the actual usage data accumulated, records were maintained indicating each time a pressure vessel was charged and its condition. These data were compiled to maintain a cyclic and historical log of pressure vessels. The data were also used at the end of the field evaluation in selecting vessels to be destructively tested.

At the end of the field evaluation, most of the firefighters participating in the program were privately interviewed to obtain as much personal comment as possible. A representative sample interview form, the major results of the interviews, and an information matrix of all the interviews are contained in appendix E.

Usage of the FBS based on the reporting forms returned totaled 961 (Houston, 95; New York, 734; Los Angeles, 132), whereas usage based on post-field-evaluation interviews totaled 1645 (Houston, 119; New York, 1195; Los Angeles, 331). Some FBS usage was not reported on the forms provided unless significant new comments were also available. Because approximately 25 percent of the users were not available for the final interview, the FBS usage during field evaluation is estimated to be more than 2000.

Field evaluation results.- The results of the field evaluation given here are the product of an assemblage of information from the FBS evaluation forms, the post-field-evaluation interviews, and observations by NASA and contractor personnel. The value of the field evaluation rests not only on the ability to cope with the correct malfunctions, but also on the ability to analyze and evaluate firefighters' comments and experiences.

When compared to existing breathing systems, the overwhelming majority of firefighters rate the FBS as being significantly superior. As expected, however, the field evaluation revealed, in addition to desirable system improvements, a variety of problems. A few of the deficiencies were serious and demanded immediate attention, although most were in the category of desirable changes to improve operational characteristics. If cost and schedule allowed, these changes were made; if not, the information was documented for potential manufacturer use.

The three cities participating in the field evaluation represent a variety of fire department breathing apparatus policies, and, consequently, the effect of these lightweight systems was different for each department.

Although the effect of the FBS was considerable in each city, it was less in Los Angeles than in the other cities. The LACFD already had in effect a strong breathing apparatus policy that requires the firefighter to wear a breathing apparatus into any structure that either is on fire or is suspected of having a fire. Therefore, the typical LACFD firefighter is somewhat acclimated to carrying a breathing apparatus, and the favorable comments attributable to just having breathing equipment with the firefighter are not mentioned. Los Angeles began the evaluation with the larger and heavier 1.7-cubic meter (60 SCF) pressure vessel. The 3-kilogram (7 pound) weight reduction is not nearly as dramatic as the 6-kilogram (13 pound) reduction for the 1.2-cubic meter (42 SCF) bottle; thus, weight reduction was not a major factor with LACFD firefighters. Extended duration and increased comfort were much more important features. Engine Company 227 was equipped with two 1.2-cubic meter (42 SCF) FBS units as firstline equipment for the last month of the evaluation.

It is interesting to note that the LACFD firefighters exposed to the smaller vessel were impressed by the light weight and the maneuverability. The small pressure vessels were not in Los Angeles long enough for a thorough evaluation, and in 18 percent of the Los Angeles usage, the durations were longer than the small vessel could have accommodated. Several of these uses were cases where firefighters continued operation because the FBS duration was available, but there were clearly some cases where the longer duration resulted in increased efficiency and reduced property loss.

A frequent comment from both the officers and the members of the LACFD was the need for a "buddy" breathing capability. This desire was stressed from the first indoctrination meeting in 1974 until final interviews in September 1975.

One of the major points of controversy in Los Angeles was the adequacy of the warning system. Indeed, the only reportable injury associated with the program occurred when a fireman was overcome by smoke after not noticing the warning tone. Although this was the only occurrence in more than 2000 uses, only 37 percent of the firefighters believed that the volume of the warning system was adequate. The problem was more apparent in Los Angeles because of the moderate usage and long-duration cylinders, which resulted in few warnings at the fire scene and therefore a lack of familiarity with the warning tone. However, it must be assumed that this situation will be the rule, not the exception, and even a 0.05-percent injury rate due to this type

of problem is not acceptable. The great majority of firefighters (90 percent) prefer the FBS type of warning system, but of these, 60 percent believe that it should be louder.

The breathing apparatus policy of the Fire Department of New York is not as encompassing as that of Los Angeles. For primary and some secondary companies, a measure of discretion is left to the company officer as to whether or not his personnel will use breathing apparatus. After secondary companies, all additional companies must report in with breathing apparatus. Because the equipment is often stored in side compartments or suitcases and is heavy and uncomfortable, it is frequently left behind by some or all members of the primary and secondary companies. Consequently, the NASA FBS had a marked effect on the operations of the two New York companies participating in the evaluation. Company officers reported that the combination of an efficient, lightweight, comfortable breathing apparatus with ready accessibility resulted in improved, more efficient, and safer operations.

The FDNY was primarily equipped with the small (1.2-cubic meter (42 SCF)) pressure vessels. For the last 2 months of the evaluation, a limited number of the larger 1.7-cubic meter (60 SCF) vessels were made available for evaluation. Divided opinions on weight versus duration did not exist in New York. All levels of the department from Third Class fireman to Chief believed that reduced weight took precedence over increased duration. In fact, 59 percent of the FDNY firefighters considered the reduced weight as the biggest improvement over conventional systems; an additional 23 percent considered it as one of several prime factors. Many of the firefighters of New York believed that the large vessel was too close in weight and bulk to their conventional systems and that it was defeating the purpose of the program. All the officers believed that the large pressure vessels should be restricted to special units (squads, midtown companies, fireboats, and rescue companies) for specific applications (high rise, shipboard, and warehouse fires and certain types of rescues). Another major comment in all the cities, but particularly in New York where older equipment was in use, was that breathing resistance was reduced. Although it was known before the field evaluation that this was a desirable feature, it was surprising to find that 18 percent of the firefighters overall considered it to be the primary feature, with an additional 42 percent considering it one of several features of prime importance. Eighteen percent of the firefighters overall and 23 percent of the FDNY firefighters in particular experienced some form of claustrophobia when high breathing resistance was combined with limited visibility. The problem is more prevalent in New York because of the excessively high breathing resistance and extremely limited visibility of the FDNY vintage units. In every case, the NASA FBS eliminated this situation because of its lower breathing resistance and wide angle of vision.

The high usage of the FBS in New York revealed several minor problems not noticed at the other locations. Most of these were endured for the field evaluation; however, they should be considered in any new design. The mask/regulator stowage pouch was frequently torn from the waistbelt; the waistbelt, which was too stiff, became stiffer with use; and the demand regulator locks ceased to lock after repeated use. All the facepieces in New York became seriously scratched after a few months, and although this situation did not

bother 77 percent of the members (they believed that even with scratching, visibility was still greatly improved over their conventional systems), it must still be treated as a problem.

Maneuverability, especially in the old tenement buildings, was a positive FBS feature with the New York firefighters. They were particularly enthusiastic about FBS operations on fire escapes and ladders; through casement windows, scuttle holes, and studs on center; in narrow halls and doorways; for pulling ceilings; and for forcible entry. The elimination of the regulator and pressure gage from the chest area also contributed to increased maneuverability, especially for crawling through small openings. It should be noted that of the 57 firefighters interviewed, only 3 expressed a desire to return to the front-mounted pressure gage. Most of them believed that it was an unnecessary addition that added cost and weight and reduced maneuverability.

The NASA FBS had its greatest effect on the operations of the Houston Fire Department. This department is probably more typical of the fire departments of the U.S. cities because it does not have a breathing apparatus policy as strong as that in either Los Angeles or New York; it does not have sufficient breathing apparatus available; and it does not have as heavy a fire incidence as that of New York. Therefore, the HFD is a good example of what can be accomplished in an "average" fire department when a strong breathing apparatus policy is introduced and readily accessible, lightweight, comfortable breathing apparatus is made available. The result was that these companies, when equipped with jump-seat-mounted FBS units, radically changed their operating plans, and company officers reported increased efficiency in saving both lives and property.

In Houston, reduced weight was the most often mentioned primary feature at 33 percent, and low breathing resistance was the prime factor for 20 percent of the members. The remaining 47 percent mentioned some combination of other features as having significant importance.

All the problems previously mentioned were evident to some degree in Houston; however, the biggest problem was facepiece fogging. Although some fogging occurred in all the cities (Houston, 60 percent; New York, 19 percent; Los Angeles, 20 percent), it was considered to be a significant problem by 20 percent of the Houston firefighters, compared to 5 percent in New York and none in Los Angeles. The other HFD firefighters who had fogging considered it a minor problem that they could control or eliminate with the purge valve. More than 79 percent of the firefighters in all three cities reported fogging problems with conventional equipment, most of them serious. This number was reduced by the NASA FBS to 30 percent overall, with 7 percent characterized as significant problems.

One of the minor problems encountered at the beginning of the field evaluation was the mounting of the FBS units in the cabs and jump seats of the vehicles. None of the firetrucks in any of the cities had provisions for mounting breathing equipment, especially in the cab where the officers' breathing apparatus should be located. Therefore, the units were mounted in locations that provided the greatest accessibility, and this contributed positively to the success of the field evaluation.

CONCLUSIONS AND RECOMMENDATIONS

The NASA firefighters breathing system has met all program objectives. Through use of the field evaluation phase, the heavy workloads received by the units have demonstrated the rugged, dependable, and innovative design characteristic of the system. The NASA firefighters breathing system has advanced the state of the art and the acceptability of this type of equipment.

1. In Los Angeles, where a mandatory policy of breathing apparatus use is in effect, the firefighter's job was made easier and safer.
2. In New York and in Houston, where the decision to use a breathing apparatus often rests with the individual firefighter, significant changes in attitude toward breathing apparatus were noted. Generally, the previous attitude was to carry a breathing apparatus only when absolutely necessary; when the NASA firefighters breathing system was available, firefighters preferred to take the equipment with them at all times.
3. The smaller 1.2-cubic meter (42 SCF) pressure vessel represents the best compromise between weight and duration.

The following recommendations for improvement to the NASA FBS are based on information obtained from users of the system and from extensive field evaluations.

1. Initial manufacturing efforts should be directed toward the small 1.2-cubic meter (42 SCF) pressure vessel.
2. Larger pressure vessels should be provided for special operations such as high rise, warehouse, and shipboard fires. This type of bottle should be carried as backup equipment for companies encountering such fires.
3. Firetrucks should be designed with (and fire departments should so specify) the location of breathing equipment taken into consideration. Wells should be designed in the cab such that the backplate of the breathing apparatus is flush with the seat. Similarly, if the breathing apparatus serves as the back of a jump seat, the manufacturers of the firetruck, breathing apparatus, and brackets should design it as such.
4. The volume and/or frequency of the warning tone should be altered to increase the ability of the firefighter to hear the system warning.
5. Facepiece materials or coatings that will eliminate or reduce scratching should be developed. An alternate approach would be to develop cheap, replaceable lenses.
6. All the flow from the demand regulator should be directed over the facepiece visor to further reduce fogging.
7. The chest-mounted pressure gages should be eliminated from future designs to reduce cost and interference and to increase reliability.

TABLE XII.- FBS PRODUCT IMPROVEMENT RECOMMENDATIONS

Problem	Recommendation
Screws are coming loose in service.	Provide all screws with locking provisions or apply Loctite at time of assembly.
Silicone O-ring in "quick disconnect" is easily cut during assembly/disassembly.	Evaluate alternate O-ring materials (such as ethylene propylene) that can still meet high/low temperature requirements.
Leakage frequently occurs at the CGA 1340 connector due to damage to the Teflon seal or to the sealing surface in the aluminum valve.	Evaluate alternate, more resilient O-ring materials (such as ethylene propylene); also provide a harder mating surface (such as hard anodized) inside the valve portion or consider a softer material for the 1340 nipple.
Straps are fraying where they pass through adjusting buckles; waist-belt adjustment is difficult to operate (too stiff).	Consider using alternate strap material or alternate adjusting mechanism.
Mask stowage pouch is difficult to use, particularly when wet, and pouch location needs improvement.	Evaluate alternate method of holding mask to waistbelt. A larger pouch or a cup-shaped flap should be considered.
Demand regulator gets dirty, both inside and outside.	Design demand regulator for easy cleaning. Complete immersion in soap and water would be ideal.
Vent ports on the pressure reducer can allow water and dirt to enter the piston area. This could be particularly bad in subfreezing weather because ice could interfere with piston operation.	Provide vent ports with porous plugs or other devices to prevent water entry. A return to the original diaphragm design would also eliminate this problem.
Brass rivets that attach the waist-belt to the back frame become bent due to carrying the unit by the waistbelt, which allows the weight of the unit to pull on the rivets.	Consider using stainless steel or putting a stainless steel washer behind the brass rivet in the production version.

TABLE XII.- Concluded

Problem	Recommendation
<p>Low-pressure hose gets very stiff in cold temperatures (noted during the NOISH 241 K (-25° F) test).</p>	<p>Evaluate silicone or another hose material that is more flexible in cold temperatures.</p>
<p>Demand regulator is difficult to rotate into position on the mask unless well lubricated. This would be more of a problem at low temperatures. The seal is also prone to damage when the mask is not in use.</p>	<p>Improve the seal between the demand regulator and the mask to eliminate the need for lubrication and make it less susceptible to damage.</p>
<p>White head net shows dirt quickly.</p>	<p>Make head net black or gray.</p>
<p>Cylinder valve pressure gage is susceptible to damage.</p>	<p>Provide better protection for pressure gage.</p>
<p>Shoulder straps sometimes slip off.</p>	<p>Make shoulder straps wider and stiffer.</p>
<p>Facepiece seal adjustment tabs are too small.</p>	<p>Make tabs larger.</p>
<p>Purge valve is confusing to operate.</p>	<p>Eliminate reverse threads.</p>
<p>Low-pressure hose limits head movement for tall firefighters.</p>	<p>Make low-pressure hose longer.</p>
<p>Some firefighters' noses touch the facepiece.</p>	<p>Increase facepiece dimensions to eliminate this interference.</p>
<p>Waistbelt blocks access to turnout coat pockets for some firefighters. (This condition also exists with conventional breathing apparatus.)</p>	<p>Reposition turnout coat pockets to allow for breathing apparatus (the FBS harness must attach around the waist).</p>

8. Each firefighter should be equipped with his own facepiece, stowed in a chest-mounted turnout coat pouch. The demand regulator should be stored in a small, portable pouch located at the discretion of the user.

A listing of recommendations based on some of the less significant problems encountered is given in table XII. Because of cost and schedule constraints, these problems were either temporarily corrected or tolerated for the duration of field evaluation.

Lyndon B. Johnson Space Center
National Aeronautics and Space Administration
Houston, Texas, February 10, 1977
141-95-01-41-72

REFERENCES

1. Sullivan, J. L.: Final Report: Compressed Air Demand-Type Firefighter's Breathing System. NASA CR-144562, 1975.
2. Beck, E. J.: Firefighters Compressed Air Breathing System Pressure Vessel Development Report. NASA CR-134384, 1974.
3. King, H. A.: Improved Firemen's Compressed Air Breathing System Pressure Vessel Development Program. NASA CR-134385, 1973.

APPENDIX A
BUREAU OF EXPLOSIVES
SAFETY RELIEF DEVICE APPROVAL

AMERICAN RAILROADS

OPERATIONS AND MAINTENANCE DEPARTMENT • BUREAU OF EXPLOSIVES
AMERICAN RAILROADS BUILDING • WASHINGTON, D.C. 20036 • 202/293-4048

C. R. MANION
Vice President

R. M. GRAZIANO
Director

DOT S.P. 6747
272-1-211
SLF-RM
January 7, 1974

Mr. Pat McLaughlan, Technical Monitor
Crew Systems Divn.-Mail Code EC6
National Aeronautics and Space Administration
Lyndon B. Johnson Space Center
Houston, Texas 77058

Dear Mr. McLaughlan:

Reference your request for Bureau Approval of safety relief device
Scott Aviation P/N 27238 for use on FBS cylinders shipped under DOT
S.P. 6747.

Be advised that based upon the successful fire-tests, Scott Aviation
P/N 27238 safety relief device is approved for use on cylinders complying
with DOT Special Permit 6747 not exceeding 60 SCF capacity and charged to
not more than 4000 psig with a non-liquefied gas.

This approval is issued pursuant to Section 173.34(d) of the DOT
Regulations.

If we may be of further service please advise.

Very truly yours

R. M. Graziano
Director

Attachment - Invoice BEL 001273
cc: Dr. Robert Gordon, President
Structural Composites Industries, Inc.
6344 N. Irwindale Avenue
Azusa, California 91702

C. A. Cummons, Inspector

APPENDIX B
DEPARTMENT OF TRANSPORTATION
SPECIAL PERMIT NO. 6747



DEPARTMENT OF TRANSPORTATION
MATERIALS TRANSPORTATION BUREAU
WASHINGTON, D.C. 20590

SPECIAL PERMIT NO. 6747
SECOND REVISION

Pursuant to 49 CFR 170.15 of the Department of Transportation (DOT) Hazardous Materials Regulations, as amended, and on the basis of the May 30, 1975 petition by National Aeronautics and Space Administration, Houston, Texas.

Special Permit No. 6747 is hereby amended as follows:

1. Shipment of charged cylinders constructed after August 15, 1975 is not authorized.
2. Paragraph (11) is changed to read as follows:
 11. EXPIRATION DATE. December 31, 1975.

All other terms of this permit, as revised, remain unchanged. The complete permit currently in effect consists of the First and Second Revisions.

Issued at Washington, D.C.:

A handwritten signature in dark ink, appearing to read "Alan I. Roberts", is written over a horizontal line.

Alan I. Roberts
Director
Office of Hazardous Materials Operations

A handwritten date "8/5/75" is written in dark ink over a horizontal line.

(DATE)

Address of inquiries to: Director, Office of Hazardous Materials Operations, U.S. Department of Transportation, Washington, D.C. 20590. Attention: Special Permits.

Dist: a, c, d, e
Structural Composites Industries Inc., Azusa, Calif.
Martin Marietta Corporation, Denver, Colorado
Scott Aviation, Lancaster, New York



DEPARTMENT OF TRANSPORTATION
HAZARDOUS MATERIALS REGULATIONS BOARD
WASHINGTON, D.C. 20590

SPECIAL PERMIT NO. 6747
FIRST REVISION
(COMPLETE)

This special permit is reissued pursuant to 49 CFR 170.15 of the Department of Transportation (DOT) Hazardous Materials Regulations, as amended to authorize shipments of a non-flammable, compressed gas under conditions as prescribed herein. This permit does not relieve any shipper or carrier from compliance with any requirement of the DOT regulations, except as specifically provided for herein.

Standard special permit requirements and conditions relating to package markings, preparation of shipping papers, shipping experience reports, etc., are published in 49 CFR 171.6. These requirements are part of this special permit.

1. BASIS. Petition dated March 20, 1974 by National Aeronautics and Space Administration (NASA); and Structural Composites Industries, Inc., petition received February 25, 1974.
2. COMMODITY. Compressed air.
3. PROPER SHIPPING NAME (49 CFR 172.5). Air, compressed.
4. REGULATION AFFECTED. 49 CFR 173.302(a)(1).
5. AUTHORIZED SHIPPER. The petitioners identified above, Martin Marietta, Scott Aviation and any other shipper who registers his identity with and receives acknowledgement from this Board and has a copy of the special permit.
6. PACKAGING PRESCRIBED. Non-DOT Specification fiberglass reinforced plastic (FRP), seamless, aluminum-lined cylinders made of definitely prescribed materials. Cylinders must have service pressure not exceeding 4000 psi and must comply with DOT Specification 3AA (S178.37) except as otherwise provided as follows:

S178.37 Non-DOT specification FRP seamless, aluminum-lined cylinders made of definitely prescribed materials.

S178.37-1 Compliance.

- (a) Required to be in compliance with NASA petition of December 11, 1972 and Attachments 1, 4, 5 and 6 dated March 11, 1974.

Continuation of 1st Rev. SP 6747

S178.37-2 Seamless, not over 554 cu. in. (20 lbs. water capacity), and service pressure not over 4000 psi.

S178.37-3 and -4.

Inspection and the quality control will be the responsibility of NASA as described in their petition, and in Attachment #1 dated March 11, 1974. When NASA completes the review of test results, a detailed report must be submitted to the Board. Consideration will then be given to use of competent and disinterested inspectors acceptable to the Bureau of Explosives.

S178.37-5 Authorized materials.

(a) Aluminum liner must be 6351-T6 or 6070-T6 alloy and temper.

(b) Overwrap material must be "S-II fiberglass".

(c) Resin must be as follows:

<u>For the 60 SCF:</u>	<u>(SCI design)</u>
<u>Formulation</u>	<u>Parts by Wt.</u>

Resin-DOW DER 332	100
Curing Agent HHPA	84
Catalyst BDMA	0.5

<u>For the 40 SCF:</u>	<u>(Martin design)</u>
<u>Formulation</u>	<u>Parts by WT.</u>

Resins-EPON 828	50
EPON 1031	50
Curing Agent NMA	90
Catalyst BDMA	1.0

S178.37-8 Manufacture:

The composite cylinder must be constructed of the authorized materials of (a) aluminum seamless liner, (b) fully overwrapped with continuous glass filament wound "in plane" only or "helical and in plane" winding impregnated with resin. The liner must be sized at a pressure at least equal to the hydrostatic test pressure. Thickness of the liner must be such that post sizing compressive stresses will not exceed approximately 90 per cent of the compressive yield strength of the aluminum liner. No fissure or other defect is acceptable that is likely to weaken the finished cylinder (except those controlled predetermined flaws for test purposes) appreciably. Reasonably smooth and uniform surface

finish is required as well as no interior folding in the neck area of the liner; smooth gathering of the material in the neck area is acceptable. If not originally free of such defects, the surface may be machined or otherwise repaired to eliminate these defects. The thickness of the ends of the liner must be determined if metal is removed during fabrication.

S178.37-9

- (a) Welding or brazing for any purpose is prohibited.

S178.37-10 Wall thickness.

The liner wall thickness and overwrap concept must be such that the residual and pressure generated stresses are as shown in NASA Attachment 6 (dated 3-11-74) for the cylindrical portion. The end design must incorporate added materials to assure the stresses in this area are less than the stresses found in the cylindrical portion.

S178.37-11 Change to "Thermal treatment."

- (a) The aluminum liner must be solution heat treated and aged to the T6 temper after all forming operations and prior to pressurizing.

- (b) The resin must be cured at the temperature specified and by the process specified in the NASA contractor's procedures.

S178.37-12

- (a) Openings must be as shown in NASA sketches on file.

S178.37-14

- (c) Permanent volumetric expansion must not exceed 1% of the total volumetric expansion at test pressure.

S178.37-15 Flattening test required on liner only.

S178.37-16 Physical test required on liner only.

S178.37-17 Required on liner only, except: elongation 12% in 2" and flattening without cracking to 10 times wall thickness.

S178.37-18 Leakage test not required.

S178.37-19 Applies to liner only.

S178.37-20 Marking.

(a) Each cylinder must be permanently marked (other than stamping) in the epoxy coating in the end of the cylinder containing the valve outlet.

(b) Cylinders must be marked:

DOT- SP 6747
Numerical Serial Number
Manufacturer's Identification
Inspector's Mark
Date of Manufacture

S178.37-22 Reports are to be appropriately modified for this method of construction and materials used.

7. SPECIAL PACKAGING REQUIREMENTS.

a. Cylinder service life is not to exceed 15 years.

b. Cycling test.

(1) Prior to the initial shipment of any specific cylinder design, cyclic pressurization test must have been performed on at least one representative sample without failure as follows:

(i) Pressurization must be performed hydrostatically between approximately zero psig and the service pressure at a rate not in excess of 4 cycles per minute. Adequate recording instrumentation must be provided if equipment is to be left unattended for periods of time.

(2) Tests prescribed in subparagraph (b) (1) of this paragraph must be repeated on one random sample out of each lot of cylinders. Cylinder may then be subjected to burst test.

(3) A lot is defined as a group of cylinders fabricated by the same process and heat treated in the same equipment under the same conditions of time, temperature, and atmosphere, and must not exceed a quantity of 200 cylinders.

(4) All cylinders used in cycling tests must be destroyed.

c. Burst test.

(1) One cylinder taken at random out of each lot of cylinders shall be hydrostatically tested to destruction.

Continuation of 1st Rev. SP 6747

d. Results of cycle and burst test.

- (1) Cycling for at least 10,000 cycles without failure.
- (2) Burst pressure must exceed 9,000 psi.

e. Cylinders must be packaged in accordance with S173.301(k).

f. Each cylinder must be hydrostatically retested every 3 years in accordance with 49 CFR 173.34(e) as prescribed for DOT Specification 3HT cylinder except that retest dates must be marked in the epoxy coating in a permanent manner other than stamping.

8. MODES OF TRANSPORTATION AUTHORIZED. Passenger-carrying aircraft, cargo-only aircraft, motor vehicle, rail freight and rail express.

9. SPECIAL TRANSPORTATION REQUIREMENTS.

a. A copy of this permit, kept current, must be carried aboard each aircraft.

10. REPORTING REQUIREMENTS. Any incident involving loss of contents of the package must be reported to this Board as soon as practicable.

11. EXPIRATION DATE. August 15, 1975.

Issued at Washington, D.C.:

A. W. M. Morrison
W. R. Fiste
For the Administrator
Federal Highway Administration

August 7, 1974
(DATE)

William F. Bloop
Mac E. Rogers
For the Administrator
Federal Railroad Administration

13 August, 1974
(DATE)

Ellis C. Langford
Ellis C. Langford
For the Administrator
Federal Aviation Administration

AUG 12 1974
(DATE)

Address all inquiries to: Secretary, Hazardous Materials
Regulations Board, U.S. Department of Transportation, Washington,
D.C. 20590. Attention: Special Permits.

Dist: a, c, d, e

APPENDIX C
FIELD EVALUATION SITE DESCRIPTION

HOUSTON FIRE DEPARTMENT

FBS Program Contact: Jon B. King
Coordinator, Occupational Safety and Health
Houston Fire Department
410 Bagby Street
Houston, Texas 77002

Engine Company 16

Officers in charge: Capt. William E. Fehmer (A Shift)
Capt. Charles A. Knott (B Shift)
Capt. John E. Knoll (C Shift)

Address: Station 16
Houston Fire Department
1413 Westheimer Road
Houston, Texas

Engine Company 16 is located in a single engine house in the Montrose section of Houston. The Montrose section is an old residential area, part of which has been transformed into a "Greenwich Village" type section with old homes converted into restaurants, shops, and clubs. Many of the larger old homes have been converted into multiple-family dwellings, and the area is interspersed with light industry. Engine Company 16 is also on second-alarm call (and some first alarms) to downtown Houston, to the medical center, and to the Post Oak area, which contains many high rise buildings.

The engine is a 1967 Ward LaFrance 4-m³/min (1000 gal/min) pumper with enclosed cab and jump seats (fig. C-1). Two 1.2-m³ (42 SCF) NASA firefighters breathing systems were placed into service on December 4, 1974. One of the units was mounted in the rear-facing jump seat and the second was placed in the cab for the officer. The company's workload would be characterized as moderate.

Engine Company 28

Officers in charge: Capt. Gary M. Grimes (A Shift)
Capt. John A. Burton (B Shift)
Capt. Edward W. Mitchell (C Shift)

Address: Station 28
Houston Fire Department
5116 Westheimer Road
Houston, Texas

Engine Company 28 is located in the Post Oak area of Houston together with Ladder Company 28. Although this section is 16 kilometers (10 miles) from the downtown area, it has many new high rise buildings as well as modern multistory apartment complexes. It is also a well-known shopping center with several modern malls and department stores. Finally, the area is surrounded by single-family frame residences and townhouses. The second-alarm area for Engine Company 28 includes the area of Engine Company 16 as well as several industrial parks. The engine is a 1970 Ward LaFrance 4-m³/min (1000 gal/min) pumper with enclosed cab and jump seats (fig. C-1). Two FBS units were placed into service on December 18, 1974, with a projected completion date of May 16, 1975. One unit was mounted in the rear-facing jump seat, and the second was placed in the cab for the officer. This company's workload would also be termed as moderate.

FIRE DEPARTMENT OF NEW YORK

FBS Program Contact: Chief Joseph A. Flynn
Chief of Staff
City of New York Fire Department
110 Church Street
New York City, N.Y. 10007

Ladder Company 19

Officer in charge: Capt. Edward Szalay
Address: Ladder Company 19
City of New York Fire Department
Station 50
491 East 166th Street
Bronx, N.Y.

Ladder Company 19 is located with Engine Company 50 in the South Bronx section of New York City. The South Bronx is a very old neighborhood; many of the buildings (including schools) were built before 1900 (Ladder Company 19 was established in 1880). The structures in the area include 4- to 6-story tenements, 2- or 3-story frame residences, 14- to 21-story high rise apartments, one-story commercial buildings, a hospital, and some heavy industry. The company's multiple-alarm area is not substantially different from its regular area of coverage.

The vehicle is a 1974 Seagrave rear-mount 30-meter (100 foot) aerial-ladder truck, with fully enclosed cab and jump seats. Three 1.2-m³ (42 SCF) FBS units were placed into service on January 7, 1975. Two units were mounted in the forward-facing jump seats and one in the cab (fig. C-2). Ladder Company 19's workload would be characterized as heavy.

Squad Company 4

Officer in charge: Capt. James J. Manahan
Address: Squad Company 4
City of New York Fire Department
Station 283
885 Howard Avenue
Brooklyn, N.Y. 11212

Squad companies were established in the early 1960's to alleviate the heavy workload on selected engine companies and to assist at working fires in their areas, acting as either a ladder or an engine company. Squad Company 4 is located in the Brownsville section of Brooklyn together with Engine Company 283. Like the South Bronx, this is also a very old neighborhood and is considered a ghetto area. As a squad, this company covers a relatively large area. The structures consist of 3- or 4-story tenements, 14- to 22-story high rise apartments, 1- or 2-story commercial buildings, light and heavy industry, schools, hospitals, and nursing homes. The company's multiple-alarm area is not substantially different from its usual area but, as a squad, the company can be called to any fire in the city.

The vehicle is a 1972 Mack 4-m³/min (1000 gal/min) pumper and carries both engine and truck company equipment (fig. C-3). Three FBS units were placed into service on February 20, 1975. Two units were placed in the rear-facing jump seats and one unit was placed in the front seat for the officer. This company's workload would be termed as extremely heavy.

LOS ANGELES CITY FIRE DEPARTMENT

FBS Program Contact: Chief William R. Blair
Chief, Battalion 5
Station 27
Los Angeles City Fire Department
1355 North Cahuenga Boulevard
Los Angeles, Calif. 90028

Task Force 27

Officers in charge: Capt. Ralph C. Rook (A Platoon)
Capt. James F. Person (B Platoon)
Capt. Edward A. Burns (C Platoon)

Address: Task Force 27
Station 27
Los Angeles City Fire Department
1355 North Cahuenga Boulevard
Los Angeles, Calif. 90028

Task Force 27 is located in the Hollywood section of Los Angeles just a few blocks from the famous intersection of Hollywood and Vine. Although this might evoke visions of wide, palm-lined boulevards, chic shops, and rambling estates, there is another element to Hollywood: many small, old frame dwellings on narrow winding streets, dilapidated hotels, bars, massage parlors, and cheap motels. In addition, there are modern high rise office, apartment, and hotel buildings; schools; hospitals; motion picture studios; and light industry. An additional problem for Task Force 27, but by no means the least, is brush fires in the Hollywood hills (nearly 500 homes were destroyed in the Bel-Aire brush fire in the 1960's).

Task Force 27 is designated as a heavy-duty task force consisting of the following three companies (fig. C-4).

1. Engine Company 27 - A two-piece company consisting of a 1972 Crown 6-m³/min (1500 gal/min) pumper (designated as Pump or P27), and a 1971 Crown 6-m³/min (1500 gal/min) Pumper/15-meter (50 foot) Snorkel Combination (designated as Wagon or W27)
2. Engine Company 227 - A one-vehicle company with a 1972 Crown 6-m³/min (1500 gal/min) Pumper (designated as E227)
3. Truck Company 27 - A one-vehicle company with a 1973 Thibault 30-meter (100 foot) Aerial Ladder with Tiller (designated as T27)

Six FBS units and a spare unit were placed in service with Task Force 27 on March 10, 1975, with a projected completion date of September 12, 1975. Two FBS units were mounted on each of W27, E227 and T27, and the spare unit was temporarily mounted in the front seat of W27. Because of the narrowness and lack of depth of the jump seats on the Los Angeles fire department rigs, the FBS units could not be mounted on the jump seats. Instead, the units were mounted as close as possible to the jump seats so that en route checkout could be accomplished (fig. C-4). The Task Force workload would be characterized as moderate to heavy.

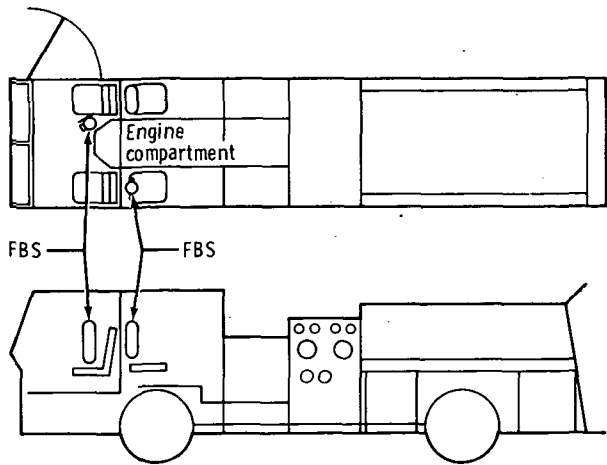

Figure C-1.- Houston firetruck layout, Engine Companies 16 and 28.

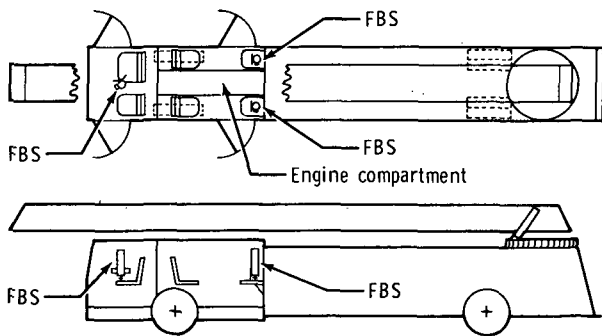

Figure C-2.- New York firetruck layout, Ladder Company 19.

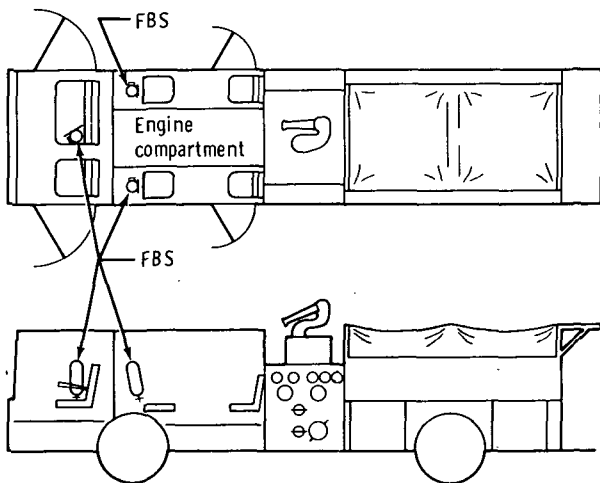
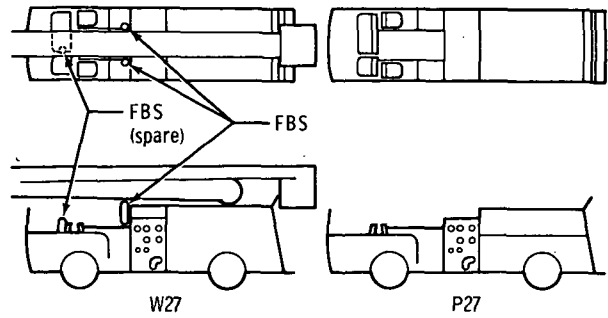
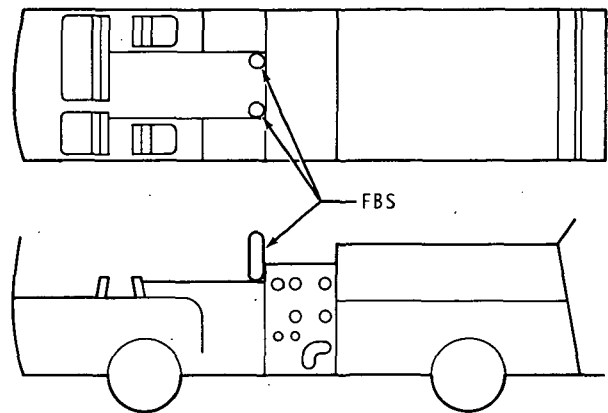

Figure C-3.- New York firetruck layout, Squad Company 4.



(a) Engine Company 27.



(b) Engine Company 227.

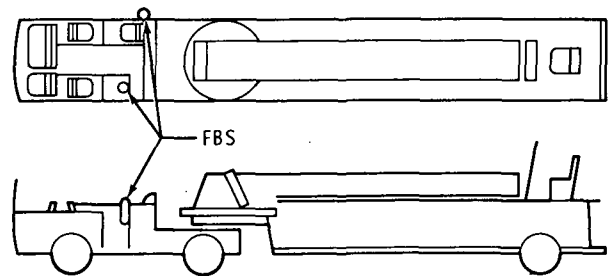

(c) Truck Company 27.

Figure C-4.- Los Angeles firetruck layout, Task Force 27.

APPENDIX D
FIELD EVALUATION SUPPORT EQUIPMENT

MOUNTING BRACKETS

The firefighters breathing system (FBS) units were mounted to the various pieces of firefighting apparatus using brackets supplied by the Ziamatic Company. These are standard mounting brackets with spring steel capture clamps that were modified to accept the FBS pressure vessel. Two sizes of brackets were required to accept the difference in diameter in the 1.2- and 1.7-cubic meter (42 and 60 SCF) vessels. This type of mounting bracket is designed to allow the user to release the FBS tiedown strap, back up to the unit and don the shoulder straps, and lean forward and walk away while securing the waist belt. These brackets were also used to carry spare pressure vessels on the firefighting vehicles.

COMPRESSED-AIR CHARGING EQUIPMENT

Most fire departments currently use either compressed-air cylinders that are charged to 15 270 kilopascals (2215 psig) by a compressor station which draws in atmospheric air and supplies it to high-pressure storage cylinders for charging or commercially available 15 170-kilopascal (2200 psig) supply cylinders. Charging the higher pressure (27 600 kilopascal (4000 psig)) NASA FBS cylinders required the development of higher pressure charging equipment.

The simplest approach, and that which was selected for FBS vessel charging at New York and Los Angeles, uses commercially available 41 400-kilopascal (6000 psig) air cylinders. Figure D-1 is a schematic of the cascade charging stations that were fabricated at NASA and installed in New York and Los Angeles during field evaluations. The cascade station allows charging of as many as four FBS cylinders simultaneously. Separate valves are provided for each supply cylinder to allow cascading. By opening the valve to the lowest pressure supply cylinder, then the next highest, etc., supply cylinders may be used down to a pressure of approximately 3450 kilopascals (500 psig). A dehydrator in the system ensures dry air for charging, and a pressure regulator and relief valve prevent overcharging of FBS cylinders. Use of the cascade system required a local supplier of high-pressure 41 400-kilopascal (6000 psig) commercial air cylinders. Airco Industrial Gases, Murray Hill, New Jersey, was contracted to supply these cylinders to the New York and Los Angeles fire departments. These high-pressure commercial gas cylinders are not available throughout the country, including Houston. To provide an FBS charging capability at the NASA Lyndon B. Johnson Space Center (JSC) and the Houston Fire Department, a booster charging station was developed under subcontract to the American Instrument Company (Aminco), Silver Springs, Maryland. A schematic of the Aminco charging stand is shown in figure D-2. This system uses an oil-free diaphragm-type booster compressor that charges two high-pressure (37 900-kilopascal (5500 psig)) storage reservoirs. Air is supplied from commercial 15 170-kilopascal (2200 psig) cylinders, which are usable down to approximately 2750 kilopascals (400 psig). Air quality is assured through the use of a purification and moisture removal system. A pressure regulator and relief valve prevent overcharging of FBS cylinders.

PERFORMANCE VERIFICATION TEST EQUIPMENT

To provide FBS testing capability at JSC, a Type I test stand was developed. This stand provided flow, leakage, and pressure testing capabilities to verify FBS component performance. The test stand was configured to accept an FBS pressure vessel or a 15 170-kilopascal (2200 psig) air cylinder as a pressure source. A manikin head was adaptable to the stand to provide complete system-level checkout capabilities. Figure D-3 is a detailed schematic of the Type I test stand.

Three additional portable suitcase-type test stands were developed to provide field checkout capability of the FBS. These stands were designated as Type II test stands and provided all the functions of the Type I stand except the capability to measure regulator inlet pressure (cylinder pressure) and facepiece leakage rates. These test stands were maintained at JSC and delivered to the field on an as-required basis. Figure D-4 is a flow schematic of the Type II test stand.

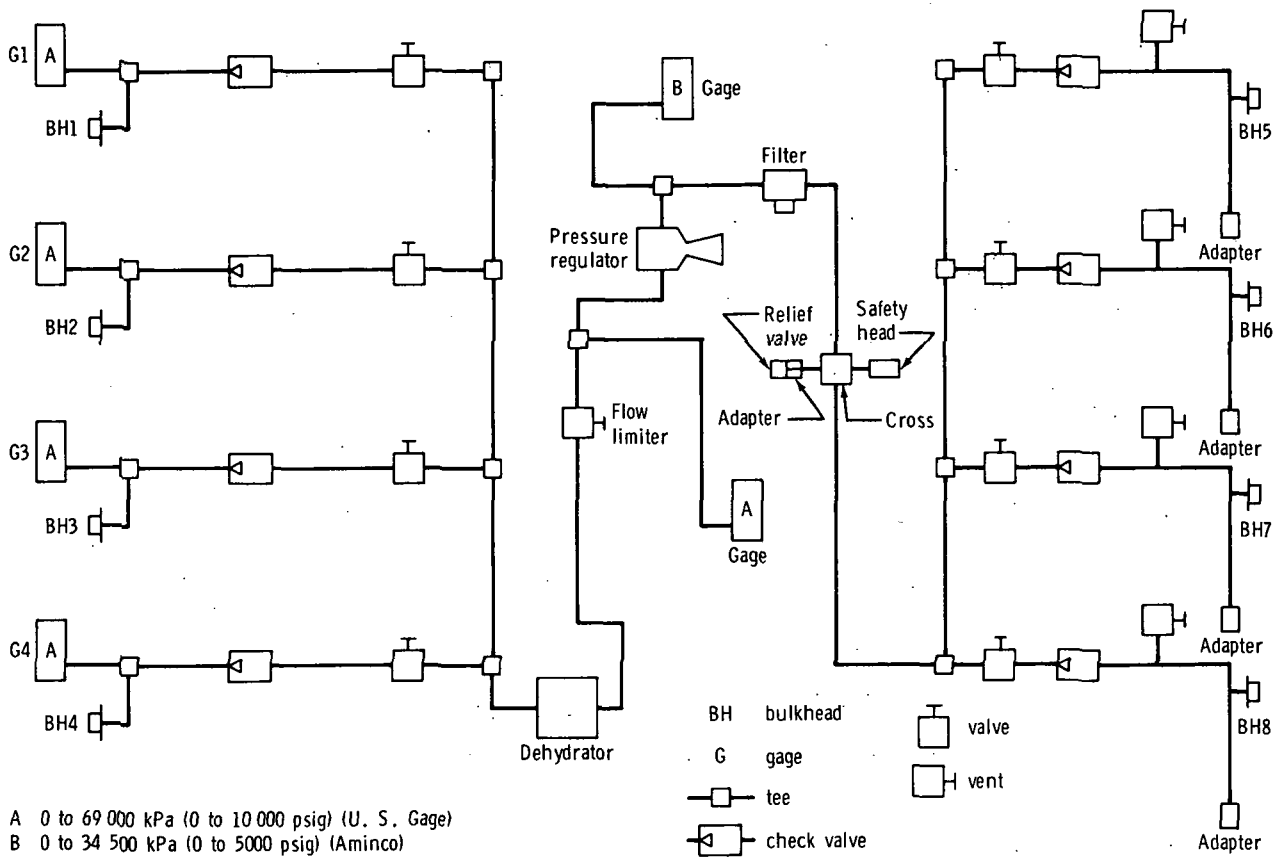

Figure D-1.- Cascade charging station schematic.

G gage
 GV gage valve
 BV ball valve
 SO shutoff valve

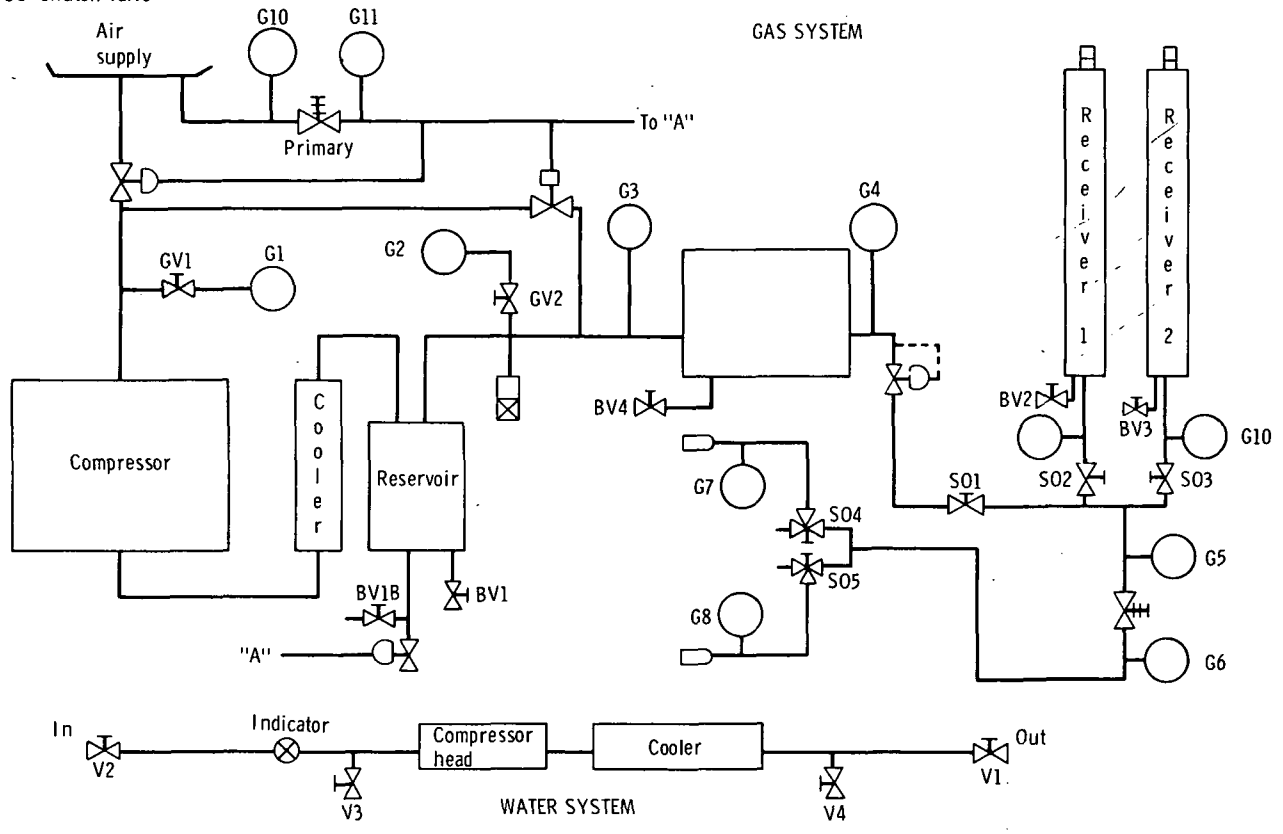

Figure D-2.- Aminco charging station schematic.

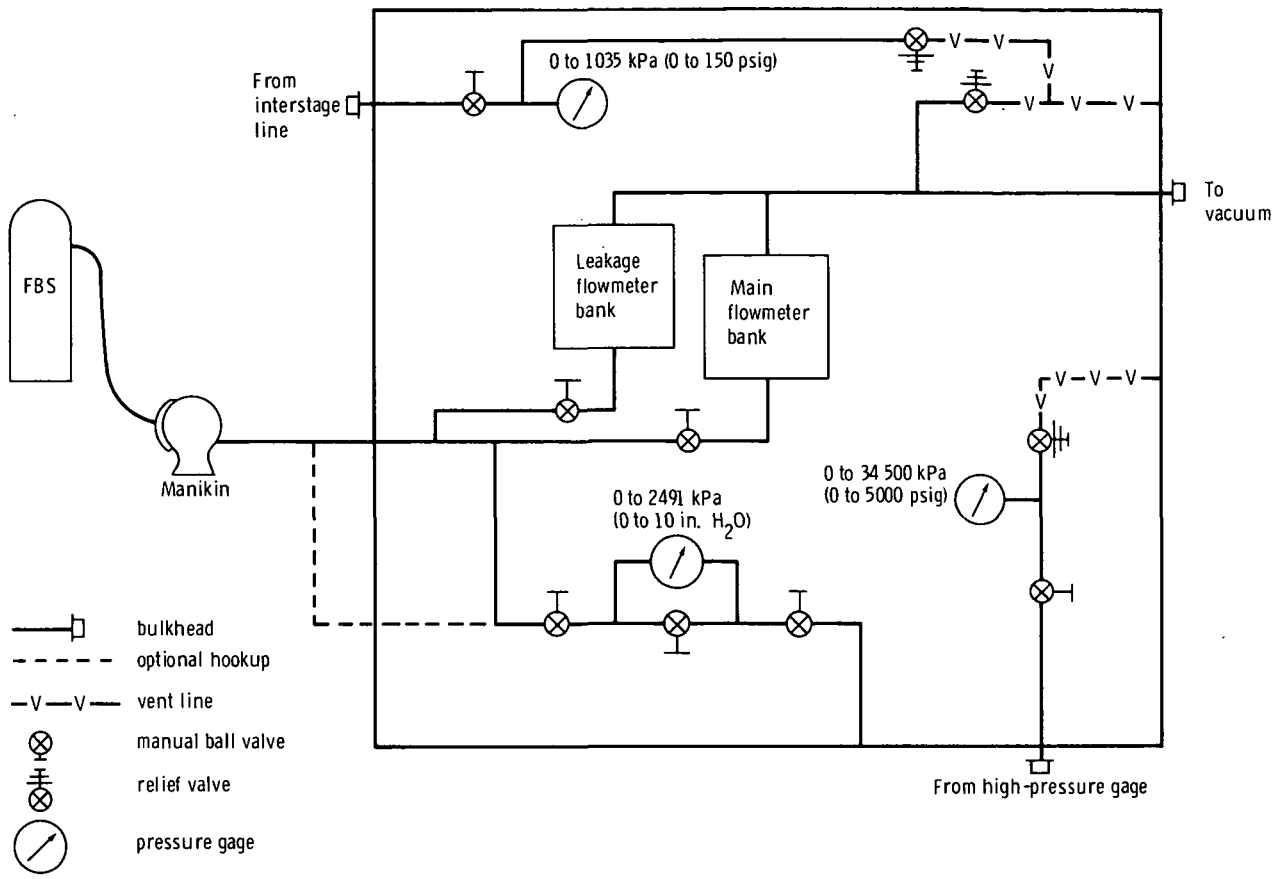
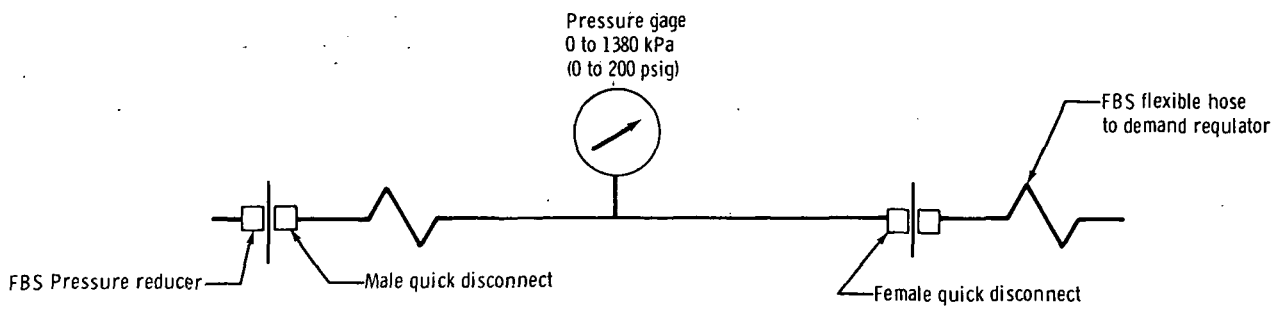
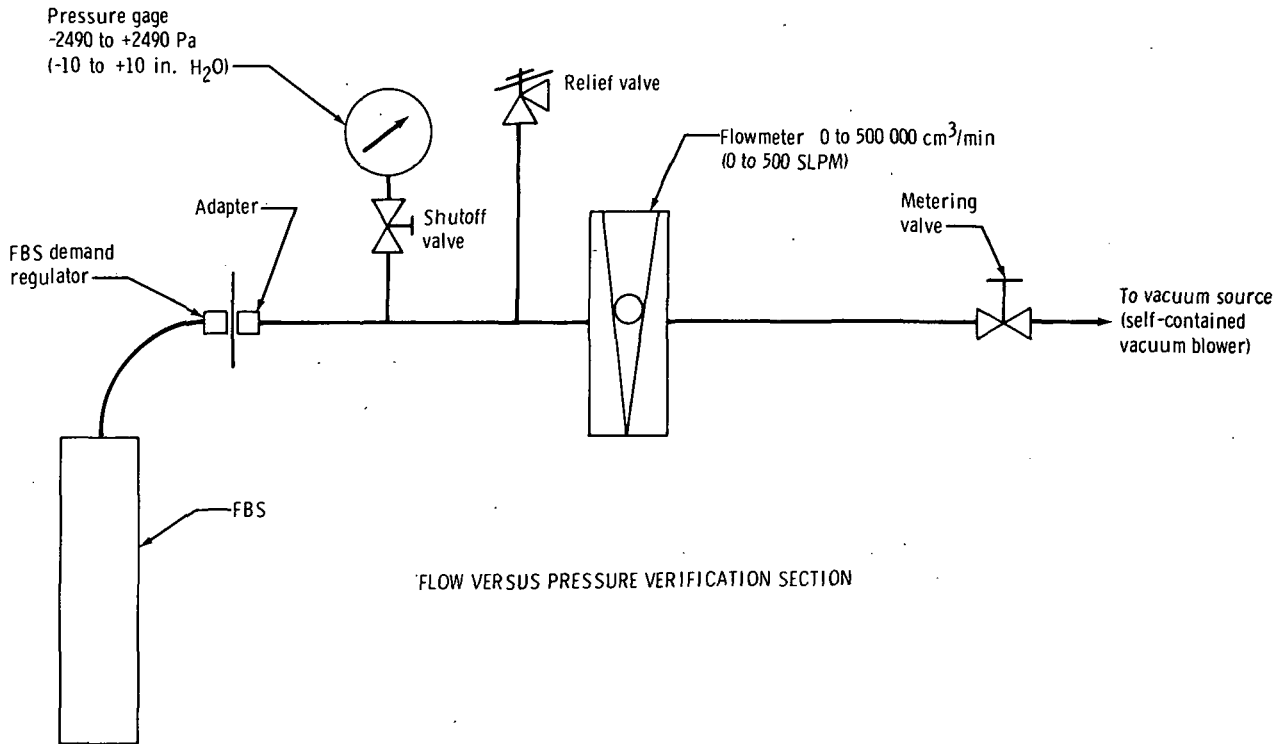

Figure D-3.- Type I FBS test stand.



INTERSTAGE PRESSURE VERIFICATION SECTION



FLOW VERSUS PRESSURE VERIFICATION SECTION

Figure D-4.- Type II FBS test stand.

APPENDIX E
FIELD EVALUATION SUMMARY

TABLE E-1.- FBS POST-FIELD-EVALUATION INTERVIEW SUMMARY

(a) Houston Fire Department (HFD)

Company	Name	Estimated no. of uses	FBS characteristic							Comments	
			Lighter weight	Comfort	Reduced breathing resistance	Visibility	Scratching	Fogging	Serious problem		Improved warning
			Unnoticed A good feature One of several prime factors The prime factor	A good feature One of several prime factors The prime factor	Unnoticed A good feature One of several (had claustrophobia) One of several prime factors The prime factor	Unnoticed One of several (had claustrophobia) One of several prime factors A good feature	Did occur, did bother Did occur but did not bother Did not occur	Did occur, was a problem Did occur but was not a problem Did not occur but had previous problem Did not occur, no previous problem	Yes (see comments) No	No good; should return to bell No good; should be louder Good but should be louder Good; don't change it	
Engine Company 16	D. W. Nobley	10	X	X	X	X	X	X	X	X	Had previous claustrophobia problems; good for attic access.
	Capt. Fehmer	5	X	X	X	X	X	X	X	X	If older units could be made more comfortable, this would be a plus.
	W. E. Walter	10	X	X	X	X	X	X	X	X	"You don't feel the tiredness in your lungs."
	Capt. Knott	0	X	X	X	X	X	X	X	X	"The first true demand regulator"; attributes maneuverability and jump-seat mounts to saving occupants on three occasions.
	A. Arnt	20	X	X	X	X	X	X	X	X	
	D. W. Curtis	25	X	X	X	X	X	X	X	X	"100-% excellent, by far the best."
	G. L. Bowers	10	X	X	X	X	X	X	X	X	"Poor comm." keeps it on for overhaul; "Lasts 5 minutes longer."
	F. D. Hooker	10	X	X	X	X	X	X	X	X	"I felt more confident."
	D. L. Haralson	10	X	X	X	X	X	X	X	X	"Great for pulling ceilings"; more stability in general.
	Capt. Little	0	X	X	X	X	X	X	X	X	"Increased the efficiency of my men and they didn't mind putting them on."
	Subtotal	100	1 4 3 2	7 3 0	0 1 3 4 2	0 3 0 7	1 0 9	0 6 2 2	0 1 0	1 3 4 2	
Engine Company 28	W. L. Moore	4	X	X	X	X	X	X	X	X	Fogging problem.
	F. S. Benefield	3	X	X	X	X	X	X	X	X	Fogging problem; works well pulling hose up a ladder.
	A. C. Young	3	X	X	X	X	X	X	X	X	
	Capt. G. M. Grimes	8	X	X	X	X	X	X	X	X	
	C. W. Key	1	X	X	X	X	X	X	X	X	Fogging problem; better suited to tight places; better center of gravity.
	Subtotal	19	0 1 1 3	4 1 0	2 1 0 1 1	3 0 0 2	0 0 5	3 0 1 1	3 2	0 0 1 4	
	Total	119	1 5 4 5	11 4 0	2 2 3 5 3	3 3 0 9	1 0 1 4	3 6 3 3	3 1 2	1 3 5 6	

TABLE E-1.- FBS POST-FIELD-EVALUATION INTERVIEW SUMMARY

(b) Fire Department of New York (FDNY)

Company	Name	Estimated no. of uses	FBS characteristic							Comments	
			Lighter weight	Comfort	Reduced breathing resistance	Visibility	Scratching	Fogging	Serious problem		Improved warning
			Unnoticed A good feature One of several prime factors The prime factor	A good feature One of several prime factors The prime factor	Unnoticed A good feature One of several prime factors The prime factor	Unnoticed One of several prime factors A good feature	Did occur, did bother Did occur but did not bother Did not occur	Did occur, was a problem Did occur but was not a problem Did not occur but had previous problem Did not occur, no previous problem	Yes (see comments) No	No good; should return to bell No good; should be louder Good but should be louder Good; don't change it	
Ladder Company 19	Lt. R. Love	20	X	X	X	X	X	X	X	X	Demand regulator came apart twice while donning (high force to connect); facepiece hit with flame (blowout), no problems, protected face; 100-X improvement in efficiency; several rescues attributable to FBS; large bottle defeats purpose; would like to see front pressure gage; FBS donned in heavy smoke, cleared. Mask always donned in smoke, no problem; good on fire escapes.
	R. Scannell	35	X	X	X	X	X	X	X	X	Always taking unit in worthwhile; didn't hear warning once.
	P. Hamill	20	X	X	X	X	X	X	X	X	"Good comfort in heavy work; if wearing Scott, I would drop it."
	P. Corcoran	30	X	X	X	X	X	X	X	X	Able to do much more work.
	R. Alair	100	X	X	X	X	X	X	X	X	Good on fire escapes.
	W. Werner	25	X	X	X	X	X	X	X	X	Regulator stuck in backup once; good for pulling ceilings.
	Lt. T. Martin	35	X	X	X	X	X	X	X	X	"There were actually times when I forgot I had it on." Good on fire escapes.
	E. Davis	15	X	X	X	X	X	X	X	X	
	P. Nealon	35	X	X	X	X	X	X	X	X	
	A. Reese	50	X	X	X	X	X	X	X	X	
	Subtotal	365	0 1 1 8	8 2 0	3 3 1 2 1	0 0 3 7	1 9 0	0 1 9 0	3 7	0 5 1 4	
Squad Company 4	R. Farrell	30	X	X	X	X	X	X	X	X	Had facepiece leakage; purge valve didn't clear well
	J. P. Walsh	50	X	X	X	X	X	X	X	X	Never used up a small bottle in 50 uses; good for pulling ceilings.
	Lt. A. Mauro	20	X	X	X	X	X	X	X	X	"Facepiece purges smoke well; large bottle noticeably heavier."
	J. Anastasio	120	X	X	X	X	X	X	X	X	Credits FBS with keeping him calm when lost in smoke-filled attic.
	J. Block	100	X	X	X	X	X	X	X	X	"While responding once, four bottles fell from apparatus to street"; no damage.
	F. P. Woods	100	X	X	X	X	X	X	X	X	"You can last longer and be more efficient."
	Lt. J. Baal	175	X	X	X	X	X	X	X	X	Good on fire escapes.
	R. Kiley	20	X	X	X	X	X	X	X	X	"Good in tight places."
	E. G. Koorse	35	X	X	X	X	X	X	X	X	"Absence of chest-mounted regulator greatly improves maneuverability"; fog clearing slower than expected.
	B. Dixon	30	X	X	X	X	X	X	X	X	"Don't miss not having chest gage at all."
	E. Brickhouse	20	X	X	X	X	X	X	X	X	"Big bottle weighs too much, I just don't need that much time."
	Capt. J. J. Manahan	130	X	X	X	X	X	X	X	X	(See fig. E-1.)
	Subtotal	830	0 3 4 5	5 6 1	2 2 4 3 1	0 3 2 7	4 8 0	1 2 9 0	1 11	1 1 3 7	
	Total	1195	0 4 5 13	13 8 1	5 5 5 5 2	0 3 5 14	5 17 0	1 3 18 0	4 18	1 6 4 11	

TABLE E-1.- FBS POST-FIELD-EVALUATION INTERVIEW SUMMARY

(c) Los Angeles City Fire Department (LACFD)

Company	Name	Estimated no. of uses	FBS characteristic							Comments	
			Lighter weight	Comfort	Reduced breathing resistance	Visibility	Scratching	Fogging	Serious problem		Improved warning
			Unnoticed A good feature One of several prime factors The prime factor	A good feature One of several prime factors The prime factor	Unnoticed A good feature (had claustrophobia) One of several prime factors The prime factor	Unnoticed One of several prime factors A good feature	Did occur, did bother. Did occur but did not bother .Did not occur	Did occur, was a problem Did occur but was not a problem Did not occur but had previous problem Did not occur, no previous problem	Yes (see comments) No	No good; should return to bell No good; should be louder Good but should be louder Good; don't change it	
Engine Company 27	R. Brandon	25	X	X	X	X	X	X	X	X	Prefers front-mounted gage; prefers small bottle due to weight.
	J. Haw	8	X	X	X	X	X	X	X	X	
	D. Moore	50	X	X	X	X	X	X	X	X	"Bottle lasts longer than body can." Prefers small bottle but likes duration.
	G. Carle	10	X	X	X	X	X	X	X	X	Increased duration is prime factor; good in high rise walkup.
	R. Maguire	30	X	X	X	X	X	X	X	X	Prefers front-mounted gage; likes increased duration.
	K. W. Drinnon	6	X	X	X	X	X	X	X	X	"I'll carry a little extra weight to get more duration."
	D. E. Bauers	10	X	X	X	X	X	X	X	X	Prefers no front pressure gage; less fatigue on men running 2-1/2 in. hoses
	Capt. D. E. Bourdon	30	X	X	X	X	X	X	X	X	Would like to see buddy breathing system added.
	Crandell	15	X	X	X	X	X	X	X	X	"Walked up eight floors then worked 25 minutes with air to spare."
	Capt. R. Brewis	3	X	X	X	X	X	X	X	X	"I want all the air I can carry"; "A vast improvement."
Truck Company 27	W. C. Bortels	20	X	X	X	X	X	X	X	X	Ran out of air using small bottle; didn't hear warning.
	T. M. Burau	6	X	X	X	X	X	X	X	X	"I've never used up large bottle, but psychologically comforting."
	Bowles	20	X	X	X	X	X	X	X	X	Prefers long duration over light weight.
	S. Cohee	6	X	X	X	X	X	X	X	X	Considers increased duration as the prime factor.
	J. Hill	15	X	X	X	X	X	X	X	X	
	C. Carnes	15	X	X	X	X	X	X	X	X	
Engine Company 227	T. Cooper	35	X	X	X	X	X	X	X	X	Much prefers small bottle; good in doorways, ceiling holes, etc.
	D. Kent	20	X	X	X	X	X	X	X	X	"I'm sold on the small bottles and they seem to be lasting plenty long enough for most operations."
	J. S. Nelson	3	X	X	X	X	X	X	X	X	
	Krokes	4	X	X	X	X	X	X	X	X	
	Total	331	2 10 5 3	13 4 3	5 4 2 4 5	7 2 2 9	1 4 15	0 4 7 9	1 19	4 1 11 4	

TABLE E-1.- FBS POST-FIELD-EVALUATION INTERVIEW SUMMARY

(d) Combined results

City	Estimated no. of uses	FBS characteristic							
		Lighter weight	Comfort	Reduced breathing resistance	Visibility	Scratching	Fogging	Serious problem	Improved warning
		Unnoticed A good feature One of several prime factors The prime factor	A good feature One of several prime factors The prime factor	Unnoticed A good feature One of several (had claustrophobia) One of several prime factors The prime factor	Unnoticed One of several (had claustrophobia) One of several prime factors A good feature	Did occur, did bother Did occur but did not bother Did not occur	Did occur, was a problem Did occur but was not a problem Did not occur but had previous problem Did not occur, no previous problem	Yes No	No good; should return to bell No good; should be louder Good but should be louder Good; don't change it
Total no. of ratings for each category ^a	1645	3 19 14 21	37 16 4	12 11 10 14 10	10 8 7 32	7 21 29	4 13 28 12	8 49	6 10 20 21
HFD, percent		7 33 26 33	74 26 0	13 13 20 31 20	20 20 0 60	20 0 93	20 40 20 20	20 80	7 20 33 40
FDNY, percent		0 18 23 59	59 36 5	23 23 23 10	0 14 23 64	23 77 0	5 14 82 0	18 82	5 27 18 50
LACFD, percent		10 50 25 15	65 20 15	25 20 10 20 25	35 10 10 45	5 20 75	0 20 35 45	5 95	20 5 55 20
Total percent		5 33 25 37	65 28 7	21 19 18 24 18	18 14 12 56	12 37 50	7 23 49 21	14 86	10 18 35 37

^a57 members (HFD, FDNY, and LACFD).

FBS PROGRAM
DEBRIEFING FORM

DATE Sept. 11, 1975

FIREFIGHTERS NAME/RANK James J. Manahan, Capt.

FIRE DEPARTMENT FDNY COMPANY Squad 4

ESTIMATED NUMBER OF USAGES 130

I. SYSTEM Final comments of the system relative to existing system and recommendations to potential manufacturers. Specify as follows:

- A. Weight: "As close to 'normal' as you're going to get."
Not restricted; could crawl, etc.
Fatigue factor: As you get older, this increases in
- B. Comfort: importance because of increased recovery time.
This reduces initial stress.
- C. Warning: No problems at all; wouldn't change it.
- D. Breathing Resistance: The major factor both physical and psychological.
Had problems with conventional.
- E. Visibility: Excellent; gives full advantage, still superior when
scratched. Occasional fogging in temperature extremes; easily fixed.
- F. Checkout: Definitely should be done; especially pressure and leakage.
- G. Ease of Donning/Doffing: Easier. Short learning curve.
- H. Bottle Changeout: No problem. Initial problems with leakage but not
after learning curve.
- I. Facepiece/Regulator Stowage: Pouches get snagged/ripped off. Sewing
flimsy. Position no good. Put bag on with snaps to individual
preference.

Figure E-1.- Sample FBS post-field-evaluation debriefing form.

I. System - continued

J. Components: (Any other comments at all on the following components)

Facepiece: The fewer parts the better.

Demand Regulator: Purge valve should have detent. Locking tab unnecessary.

Pressure Reducer: No known failures.

Handtight Bottle Connection: See changeout.

Cylinder Valve: Position is great; easier to open.

Bottle: _____

Harness Assembly: Bigger tabs would help.

II. Operational Interfaces Final comments on how well the FBS interfaced or performed relative to existing systems and recommendations to potential manufacturers. Specifically as follows:

A. Mounting Brackets/Location: Should be recessed/designed into the apparatus, two men plus officer should wear breathing apparatus.

B. Spares: More than adequate.

C. Helmet: (Leather) No problems.

D. Turnout Coat: (Globe Nomex) Pockets blocked.

E. Gloves: N/A

F. Fire: _____

G. Smoke: _____

Figure E-1.- Continued.

II. Operational Interfaces - continued

H. Heat: _____

I. Structural: Fire escapes, casement windows, attic accesses, stubs on center, working two men side by side in narrow hallways, aerial ladders.

J. Heavy Work: Pulling hose, pulling ceilings, chopping with axes, breaching a wall with a sledge, etc. High expansion foam.

III. General Comments - Any general comments or recommendations:

Would like to know why fogging occurs with some individuals and not others.

I have never experienced a breathing apparatus being accidentally shut off; the ratchet mechanism will result in valves being left on.

I hate to see any changes in NASA design (except facepiece; scratching, room, fog).

I like small bottle; large cylinders (60 SCF) should be for specialized operations (squads, midtown rescue, fireboats)

Comm: Radio comm is greatly improved.

Verbal comm is somewhat improved.

Visual comm is greatly improved.

F. A. Keune
Interviewer's signature

Figure E-1.- Concluded.



POSTMASTER: If Undeliverable (Section 158
Postal Manual) Do Not Return

"The aeronautical and space activities of the United States shall be conducted so as to contribute . . . to the expansion of human knowledge of phenomena in the atmosphere and space. The Administration shall provide for the widest practicable and appropriate dissemination of information concerning its activities and the results thereof."

—NATIONAL AERONAUTICS AND SPACE ACT OF 1958

NASA SCIENTIFIC AND TECHNICAL PUBLICATIONS

TECHNICAL REPORTS: Scientific and technical information considered important, complete, and a lasting contribution to existing knowledge.

TECHNICAL NOTES: Information less broad in scope but nevertheless of importance as a contribution to existing knowledge.

TECHNICAL MEMORANDUMS: Information receiving limited distribution because of preliminary data, security classification, or other reasons. Also includes conference proceedings with either limited or unlimited distribution.

CONTRACTOR REPORTS: Scientific and technical information generated under a NASA contract or grant and considered an important contribution to existing knowledge.

TECHNICAL TRANSLATIONS: Information published in a foreign language considered to merit NASA distribution in English.

SPECIAL PUBLICATIONS: Information derived from or of value to NASA activities. Publications include final reports of major projects, monographs, data compilations, handbooks, sourcebooks, and special bibliographies.

TECHNOLOGY UTILIZATION PUBLICATIONS: Information on technology used by NASA that may be of particular interest in commercial and other non-aerospace applications. Publications include Tech Briefs, Technology Utilization Reports and Technology Surveys.

Details on the availability of these publications may be obtained from:

SCIENTIFIC AND TECHNICAL INFORMATION OFFICE

NATIONAL AERONAUTICS AND SPACE ADMINISTRATION

Washington, D.C. 20546