

General Disclaimer

One or more of the Following Statements may affect this Document

- This document has been reproduced from the best copy furnished by the organizational source. It is being released in the interest of making available as much information as possible.
- This document may contain data, which exceeds the sheet parameters. It was furnished in this condition by the organizational source and is the best copy available.
- This document may contain tone-on-tone or color graphs, charts and/or pictures, which have been reproduced in black and white.
- This document is paginated as submitted by the original source.
- Portions of this document are not fully legible due to the historical nature of some of the material. However, it is the best reproduction available from the original submission.

(NASA-CP-2010) SOME BASIC CONSIDERATIONS OF
MEASUREMENTS INVOLVING COLLIMATED DIRECT
SUNLIGHT (NASA) 17 p HC A02/MF A01 CSCL 10A

N77-26622

Unclas

H1/44 35425

SOME BASIC CONSIDERATIONS OF MEASUREMENTS INVOLVING COLLIMATED DIRECT SUNLIGHT

An-Ti Chai

National Aeronautics and Space Administration

Lewis Research Center

Cleveland, Ohio 44135

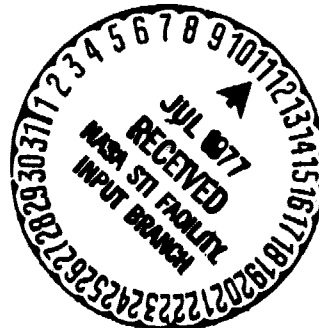

Prepared for

ENERGY RESEARCH AND DEVELOPMENT ADMINISTRATION

Office of the Assistant Administrator for

Solar, Geothermal, and Advanced Energy Systems

Division of Solar Energy

Under Interagency Agreement E(49-26)-1022

Presented at Second Annual Photovoltaic Measurements Workshop

Baton Rouge, Louisiana, November 10-12, 1976

SOME BASIC CONSIDERATIONS OF MEASUREMENTS
INVOLVING COLLIMATED DIRECT SUNLIGHT

by An-Ti Chai

Lewis Research Center
National Aeronautics and Space Administration
Cleveland, Ohio

ABSTRACT

The geometry of collimators for devices or instruments dealing with terrestrial direct sunlight is discussed. Effects of the opening angle and slope angle of a collimator on the measurements are investigated with regard to variations of turbidity and air mass. Based on this investigation, geometric dimensions for collimators and certain realistic terrestrial reference conditions are recommended for the purpose of solar cell calibration in terrestrial applications.

SUMMARY

The geometry of collimators for devices or instruments dealing with terrestrial direct sunlight is discussed. Effects of the opening angle and slope angle of a collimator on the measurements are investigated with regard to variations of atmospheric turbidity and air mass. It is pointed out that the slope angle should be specified after considering the collimator size and the tracking capability of the instrument. The size of opening angle affects the amount of circumsolar radiation and skylight entering a collimator and the uniformity of illumination at the receiving aperture. Based on this analysis, an opening angle in the range of $2.5-3^\circ$, which is equivalent to a 10 to 1 collimation ratio, with a slope angle between 1° and 1.76° should be appropriate for the purpose of solar cell

calibration in terrestrial applications.

The reference conditions, specifically the air mass and atmospheric turbidity for solar cell calibration are also discussed. It is recommended that the product of air mass and turbidity parameter be restricted to no greater than 0.25 to avoid excessive nonuniformity of illumination at the receiving aperture of a collimator.

INTRODUCTION

Owing to the technical difficulty in obtaining full knowledge of the relationship between the global solar irradiance and general atmospheric conditions, it has been a general consensus that solar cell calibration under natural sunlight should be done under collimated direct sunlight (ref. 1). In doing so, one is rid of the complication of the general sky conditions, most prominently the cloud effects; however, one is confronted with a new problem - how to construct a proper collimator.

The Joint International Radiation Conference at Davos in 1956 adopted recommendations with regard to the construction of collimators used on pyrheliometers (refs. 2 and 3). Unfortunately, these recommendations may not be universally practiced. The solar cell community, for example, has not strictly followed these recommendations. In a report entitled, "Interim Solar Cell Test Procedures for Terrestrial Applications" (ISCTPTA), which was issued in July 1975, (ref. 1) guidelines on the requirement of collimation and reference conditions were presented for calibration of standard cells. These guidelines do not appear to adequately cover the requirements of collimators in certain realistic circumstances. This paper is intended to clarify some of the confusions associated with these requirements and

to develop requirements for collimators for solar cell measurements.

BASIC CONSIDERATIONS IN COLLIMATOR DESIGN

There are three angles associated with the aperture conditions of a collimator. If the radius of the limiting aperture is R , the radius of the receiving aperture r , and the distance between them ℓ , the angles can be specified as (fig. 1)

$$\text{the opening angle: } \theta_o = \tan^{-1} \frac{R}{\ell}$$

$$\text{the slope angle: } \theta_s = \tan^{-1} \frac{R - r}{\ell}$$

$$\text{the limit angle: } \theta_\ell = \tan^{-1} \frac{R + r}{\ell}$$

According to a recommendation adopted at the Joint International Radiation Conference at Davos in September 1956, (refs. 2 and 3), the slope angle θ_s should be between 1° and 2° while the opening angle θ_o must be less than 4° . Many pyrheliometer manufacturers and instrument designers do not follow the recommendations strictly, and they often specify only one angle - the opening angle, or equivalently the full aperture angle, central angle, acceptance angle, field of view, etc., which are two times the opening angle. Frequently the ratio of a collimating tube length to its diameter (or aperture diameter) is also used.

Specification of two of the three basic angles is necessary and sufficient for complete design of a collimator. Opening angle and slope angle are usually used for this purpose. In the following sections effects of these two angles on measurements will be analyzed with respect to potential tracking and radiation errors.

Slope Angle

The slope angle of a collimator is determined by several factors: (angular) size of the light source, initial pointing error, and subsequent tracking error of the instrument during measurements. To show the importance of having a proper slope angle, consider an extreme case, say $\theta_s = 0$.

If the collimator is perfectly aimed at the center of the solar disk, a point near the edge of the receiving area at the bottom of the tube views only part of the solar disk (fig. 2). This leads to a nonuniformity of intensity on the receiving area. Pointing error and tracking error make the situation worse; the solar disk can be out of the view completely from certain edge points. The nonuniformity of irradiance at the receiving area could be large under these circumstances.

It is quite obvious that even if the collimator is perfectly aimed, the slope angle has to be at least half the angular span of the solar disk so that all parts at the receiving area can be illuminated by the entire solar disk. Allowing imperfect aiming, it is necessary to have a slope angle not less than the sum of: (a) one-half of the angular span of the solar disk, from center to rim (0.26°); (b) initial pointing error; and (c) subsequent tracking error of the device.

In ISCTPTA the tracking accuracy was allowed to be $\pm 2^\circ$. If the allowed pointing error were as low as 0.25° , the slope angle of the collimator would have to be 2.76° . If the full aperture angle ($2\theta_0$) is 5.7° as specified in ISCTPTA, and the radius of receiving area is 1.5 cm for a typical 2 cm x 2 cm size standard cell, then the length of the collimator must be over 837 cm.

Collimators of such length are quite impractical for day-to-day calibration of solar cells.

In view of the fact that there are inexpensive solar trackers commercially available with accuracy better than 1° , the tracking requirement should be within $\pm(\theta_s - 0.76^\circ)$ with θ_s , the slope angle, specified no greater than 1.76° . With better tracking, smaller slope angles can be used but should be no less than 1° .

Opening Angle

The size of the opening angle determines how much radiation passes through the collimator. In addition to the direct solar radiation, circumsolar radiation and skylight also enter the collimator due to Mie scattering by atmospheric aerosols and Rayleigh scattering by atmospheric molecules. Ideally, one would like to use a collimator of very small opening angle to eliminate the circumsolar radiation and skylight; however, it is not practical to decrease the opening angle much below $5.7^\circ/2$, which is equivalent to the 10 to 1 collimation ratio found on many commercial pyreheliometers. For example, consider a collimator of 20 to 1 ratio (opening angle of 1.43°). If the slope angle is 1.26° as discussed in the previous section, a 1.5 cm radius receiving aperture would require a collimator nearly 500 cm in length. Even with a slope angle of 1° , the length would be close to 200 cm. Thus a 20 to 1 collimator is much too long for practical use. In the following discussion, the comparisons are made only between collimators of 10 to 1 and 5 to 1 ratios in order to estimate the circumsolar radiation and skylight received through the collimator, uniformity, and relative errors in measurement.

Circumsolar radiation received through the collimator. - The circumsolar radiation due to Mie scattering by atmospheric aerosols is highly directional, with its major portion concentrated in the forward direction. In actual measurement, it is difficult to separate the forward scattered light from the direct sunlight. A certain amount of circumsolar radiation must be included in the measurement.

Summarizing the data and analysis from a number of investigators, Angstrom and Rodhe (ref. 4) presented in graphical form the dependence of radiation from the solar aureole on turbidity parameter $m\beta$ and on full aperture angle of a measuring instrument. The graph of this relationship is reproduced here (fig. 3) for reference. The relative air mass is m and β is the turbidity coefficient. The amount of circumsolar radiation is measured in percentage of the direct radiation from the solar disk.

According to figure 3, for $m\beta = 0.2$ the circumsolar radiation received through the 10 to 1 (5.7°) collimator is 4.7% of the direct radiation and 7.8% through the 5 to 1 (11.3°) collimator. The difference in circumsolar radiation received by these two collimators is then 3.1% of direct. For $m\beta = 0.1$ this difference reduces to 1.5%. It has been proposed that use of a collimator with large opening angle which allows all of the circumsolar radiation to be included in the measurements could be advantageous. However, there are other factors such as skylight and illumination errors at the test plane to be considered.

Skylight radiation received through the collimator. - The amount of skylight (diffused Rayleigh scattering) entering the instrument also increases with the increase of the opening angle of its collimator. For a collimator of 10 to 1 ratio, $2\theta_0 = 5.7^\circ$, the solid angle subtended at the receiving

area is about 0.125% of the entire hemisphere. Excluding variations in brightness across the sky, this opening angle allows approximately 0.25% of the total skylight, which is the total flux of diffuse light received at a horizontal plane with the collimator removed, to enter the instrument. For a collimator of 5 to 1 ratio ($2\theta_0 = 11.3^\circ$), the figure should be four times that much or about 1% of the total skylight.

Because of the strong wavelength scattering dependence ($\sim 1/\lambda^4$), the Rayleigh scattering coefficient varies from 1 in the near IR to about 30 in the UV. Thus, the skylight due to Rayleigh scattering has a spectral composition significantly different from the direct sunlight; the result is a combination of disproportionately enhanced short wavelengths and much suppressed long wavelengths. Consequently, the skylight affects the solar cell performance measurements much more than the comparable amount of circumsolar light, which has a spectral distribution near to that of direct sunlight.

Preliminary observations indicate that the ratio of short circuit current output to irradiance for solar cells under skylight can be as much as 15% lower than that under normal incident direct sunlight, depending upon general sky conditions. On the other hand, no significant difference in solar cell performance has been observed between measurements with collimators of 10 to 1 ratio and those of 5 to 1 ratio. Thus, the apparent advantage of using larger opening angle to include more circumsolar light may be outweighed by the disadvantage of introducing more spectrally different skylight.

Uniformity of illumination. - The opening angle can also affect the

uniformity of illumination at the receiving aperture. With $2\theta_0 = 11.3^\circ$, the center of the receiving area gets additional radiation from the solar aureole, which amounts to approximately 8% of the direct component for $m\beta = 0.2$ (fig. 3). For slope angle of $1-2^\circ$, the circumsolar radiation that can reach the edge of the receiving area is approximately half of that received at the center, that is, approximately 4% of the direct. If we extend the turbidity and air mass range to $m\beta = 0.25$ or more, the difference can be over 5%. This difference, which is a direct measure of the nonuniformity at the receiving plane, is significantly reduced for smaller opening angles. In the case of $2\theta_0 = 5.7^\circ$, the difference should be about 2% for $m\beta = 0.2$.

Relative errors in measurement. - Relative errors in measurement due to pointing and tracking inaccuracies are also different for collimators of different opening angle. Referring to figure 4(a), let $\delta\theta$ be the sum of pointing and tracking errors. The resultant error in the radiation flux which gets through the collimator can be expressed as

$$\Delta F \sim \Delta\Omega \cdot \frac{dI}{d\theta} \quad (1)$$

where $\Delta\Omega$ is the solid angle error due to the $\delta\theta$ pointing error, $dI/d\theta$ is the gradient of the intensity of the circumsolar radiation per unit solid angle with respect to angular distance from the solar disk. The solid angle $\Delta\Omega$ can be estimated from figure 4(b). When the axis of the collimator is shifted by $\delta\theta$, a diameter at the limiting aperture perpendicular to the shift sweeps an area $(2\delta\theta)2R$. Therefore, the solid angle

$$\Delta\Omega = \frac{(\ell\delta\theta)2R}{\ell} = \frac{2R}{\ell} \delta\theta \quad (2)$$

hence

$$\Delta F \sim \frac{2R}{\ell} \cdot \frac{dI}{d\theta} \cdot \delta\theta \quad (3)$$

The quantity $dI/d\theta$, in percent of the direct solar radiation per unit solid angle, can be estimated from figure 3. For a collimator of 10 to 1 ratio $2R/\ell = 1/10$ and $dI/d\theta \sim 5m\beta(\ell^2/\pi r^2)$. Comparable values for a collimator of 5 to 1 ratio are $1/5$ and $m\beta(\ell^2/\pi r^2)$. Considering a high turbidity parameter case, say, $m\beta = 0.2$, the uncertainties associated with a pointing error of 0.5° would be around 0.2 and 0.02 percent for collimators of 10 to 1 and 5 to 1 ratios, respectively. For a lower turbidity parameter case such as $m\beta = 0.1$, they are approximately 0.1 and 0.01 percent, both small quantities.

Sizes of Collimators in Different Configurations

For given opening angle and slope angle, the size of a collimator is dictated by the size of its receiving aperture. Typical reference solar cells are 2 cm x 2 cm squares. A collimator with a receiving aperture radius of 1.5 cm is appropriate for the calibration of such cells under terrestrial sunlight. For a quick comparison, dimensions for collimators of 20 to 1, 10 to 1, and 5 to 1 ratios with different slope angles are given in Table 1. Lengths are measured in centimeters with r , the radius of the receiving aperture, fixed at 1.5 cm.

Table 1. COMPARISON OF DIMENSIONS FOR COLLIMATORS OF DIFFERENT OPENING ANGLE AND SLOPE ANGLE

Collimation Ratios	Opening Angle	Slope Angle	Receiving Aperture radius r cm	Limiting Aperture radius R cm	Collimator length l cm
20/1	1.43°	1°	1.5	4.91	198.81
		1.26°		12.48	499.12
		1.76°			
10/1	2.85°	1°	1.5	2.30	46.09
		1.26°		2.68	53.56
		1.76°		3.89	77.83
5/1	5.65°	1°	1.5	1.82	18.17
		1.26°		1.92	19.23
		1.76°		2.17	21.65

TERRESTRIAL REFERENCE CONDITIONS

In the ISCTPTA, solar cell calibration in natural sunlight requires the following atmospheric conditions: (1) turbidity coefficient β must be less than 0.2, and (2) air mass m must be between 1 and 2.5. Using the worst combination of (1) and (2), the product of $m\beta$ can be as high as 0.5, which according to a linear extrapolation of figure 3 could give circumsolar radiation as much as 20% of the direct. Under this condition, the nonuniformity of irradiance at the receiving area would be unacceptably high even with $2\theta_0 = 5.7^\circ$.

The compelling reason to allow m to be as large as 2.5 and β as high as 0.2 is to accommodate the large air mass for winter months in the northern states and the high turbidity for summer months in some populated areas. However, the turbidity parameter which plays the essential role is

the product $m\beta$. According to the survey presented by Flowers, et al. (ref. 5), the turbidity conditions in the United States have values of $m\beta$ less than about 0.25 most of the year. This occurs because in high turbidity summer months the air mass at solar noon is generally small, while in winter months the turbidity is usually lower although the air mass is large. It is recommended, therefore, that the reference conditions concerning turbidity and air mass specified in ISCTPTA be revised by adding: the product of air mass and turbidity coefficient, $m\beta$, must be no greater than 0.25.

It should be noted that the above recommendation is based solely on the consideration of accommodating the typical turbidity conditions with acceptable nonuniformities discussed previously. Other factors may call for even more stringent requirements on turbidity conditions.

CONCLUSIONS

Using collimators of large opening angle, most of the circumsolar radiation can be included in the measurement. However, for the purpose of solar cell calibration, this advantage can be outweighed by the drawbacks of introducing more skylight and the increasing nonuniformity at the receiving plane. Furthermore, a larger opening angle also makes the measurements more vulnerable to the influence of general sky conditions.

Collimators with a small opening angle such as a 20 to 1 collimation ratio are impractical to use because of their physical sizes. Commercially available pyrheliometers have $2\theta_0$ in the $5-6^\circ$ range, which is equivalent to a 10 to 1 collimation ratio, and there is no compelling reason to change it. However, it is necessary to have the slope angle of the collimator

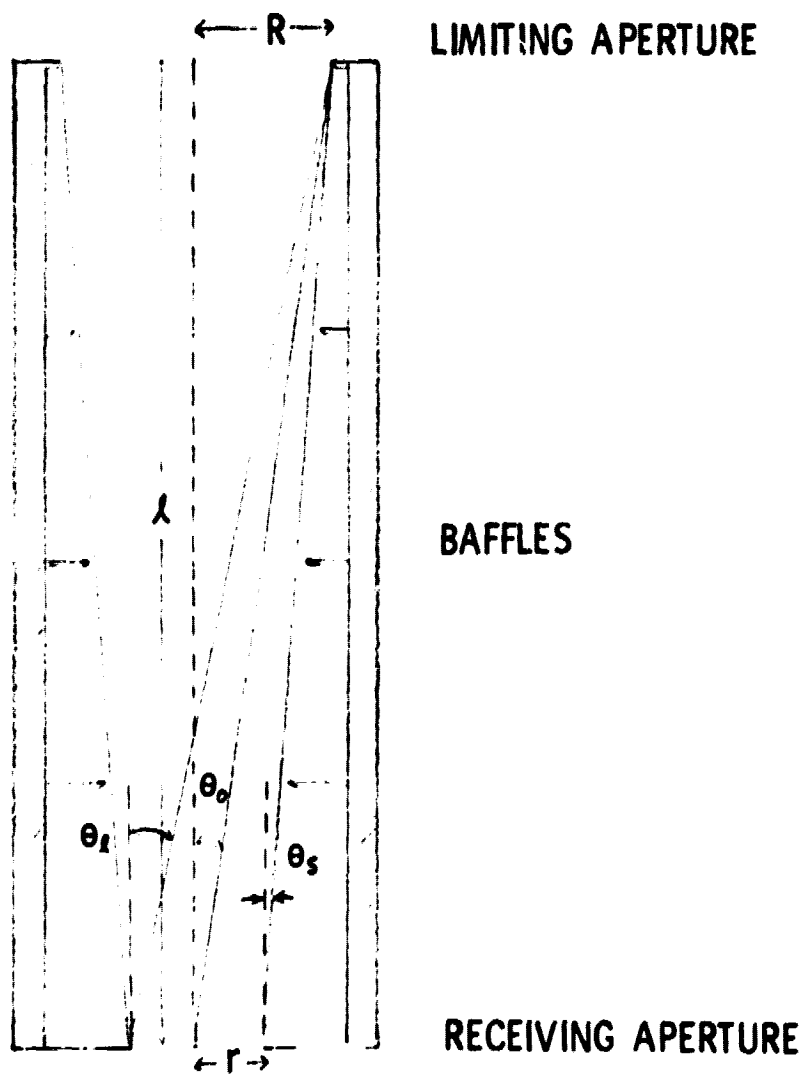

FIG. 1. CROSS-SECTIONAL VIEW OF A COLLIMATOR

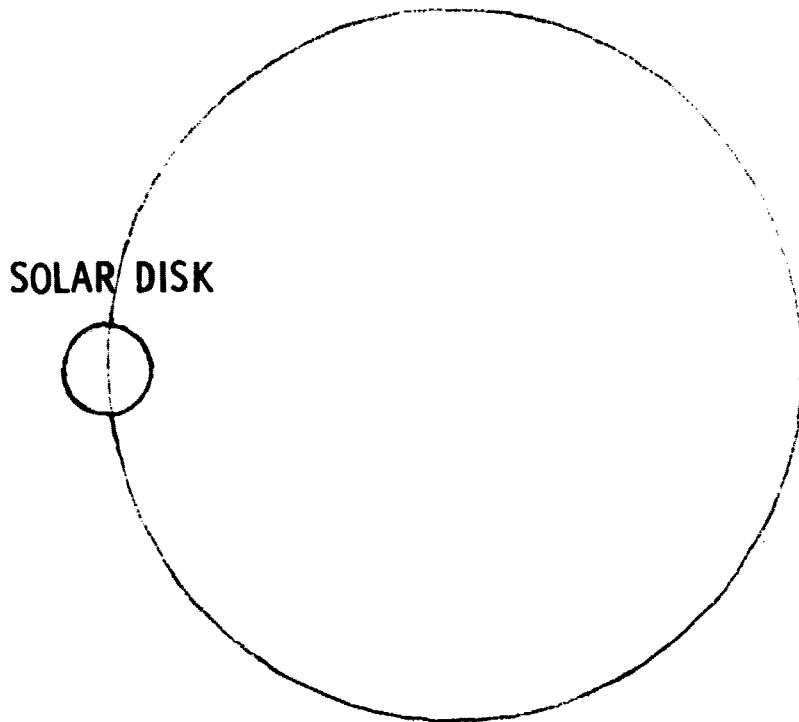

FIG. 2. A VIEW FROM AN EDGE POINT NEAR THE RECEIVING APERTURE OF A COLLIMATOR WITH ZERO SLOPE ANGLE. SHADED PART OF THE SOLAR DISK IS OUT OF SIGHT.

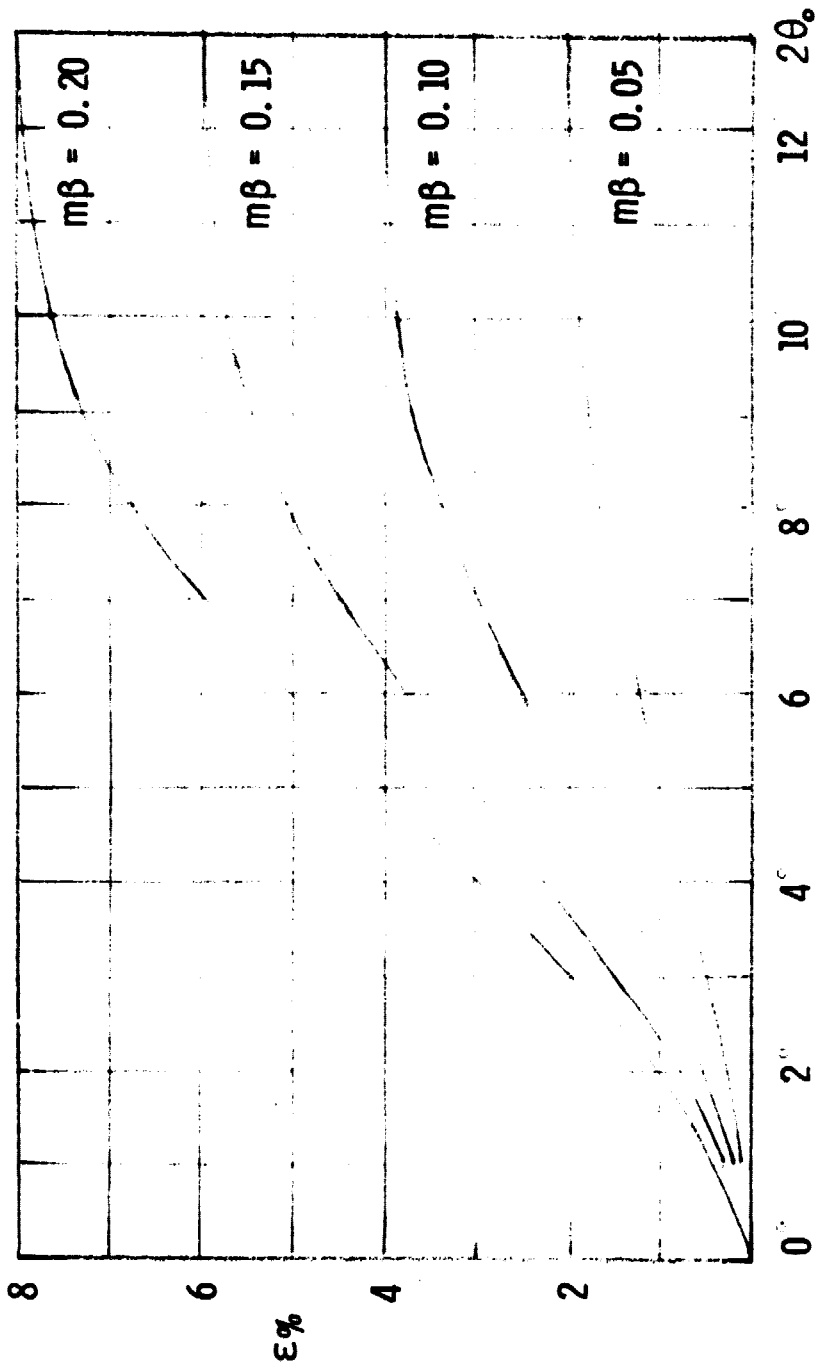

FIG. 3. DEPENDENCE OF THE RADIATION FROM THE AUREOLE ON TURBIDITY PARAMETER AND ON OPENING APERTURE OF THE INSTRUMENT. THE QUANTITY ϵ IS GIVEN IN PERCENT OF THE DIRECT SOLAR RADIATION. (REPRODUCED FROM REF. 4)

ORIGINAL PAGE IS
OF POOR QUALITY

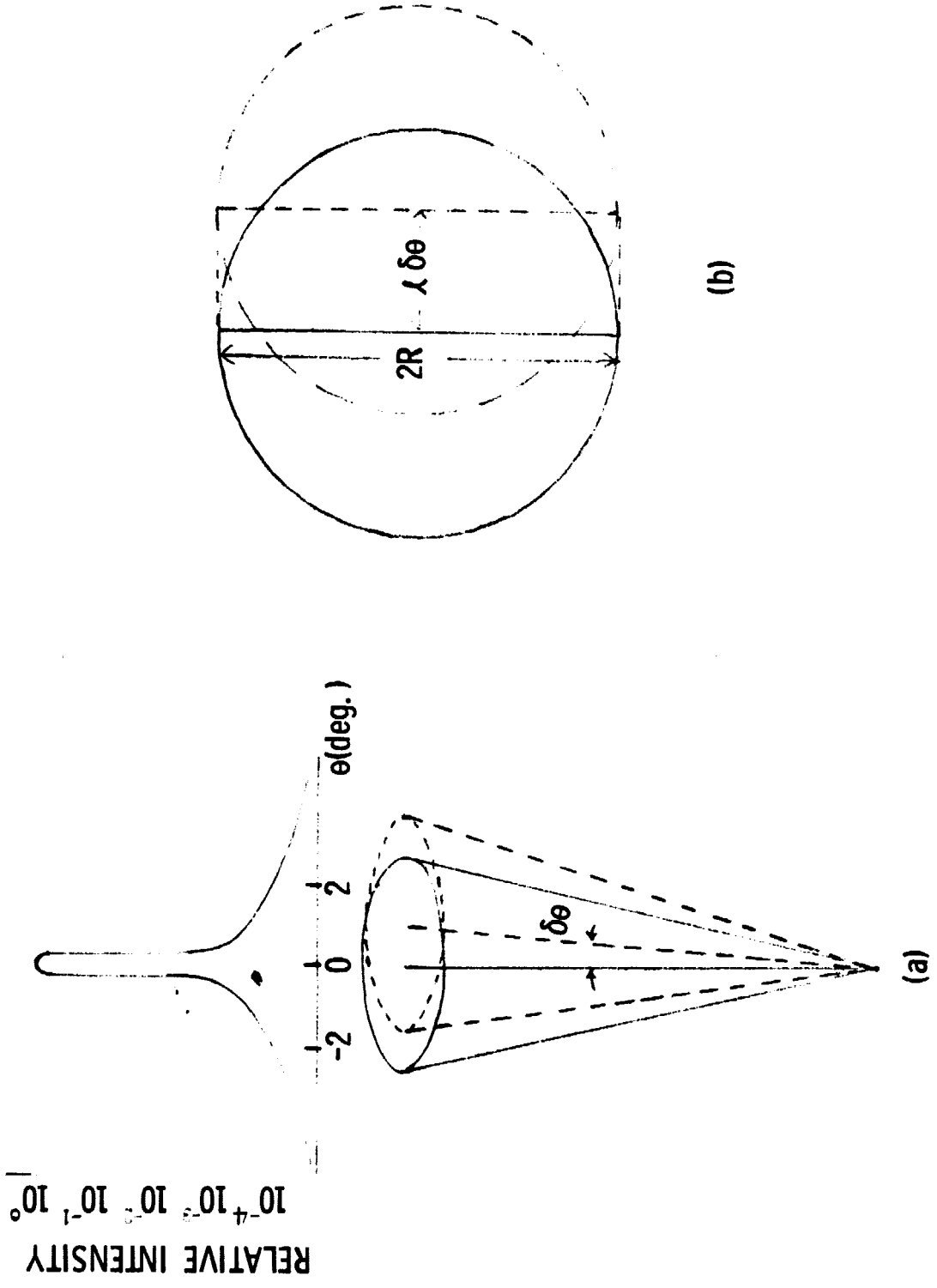

FIG. 4. (a) SIDE VIEW OF A COLLIMATOR HAVING A POINTING & TRACKING ERROR OF $\delta\theta$
 (b) TOP VIEW OF SUCH A COLLIMATOR