

FR 3770219

DRL Line Item No. C011

NAS1-9000

NASA CR-145148

April 1977

VIKING 75 PROJECT

VIKING LANDER SYSTEM
PRIMARY MISSION PERFORMANCE
REPORT

Prepared by:



C. G. Cooley

MMC Viking Project

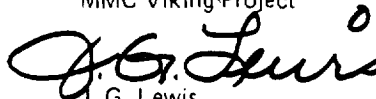

J. G. Lewis

MMC Viking Project

Approved by:



G. C. Broome

NASA Viking Project Manager

MARTIN MARIETTA CORPORATION

P. O. Box 179

Denver, Colorado 80201

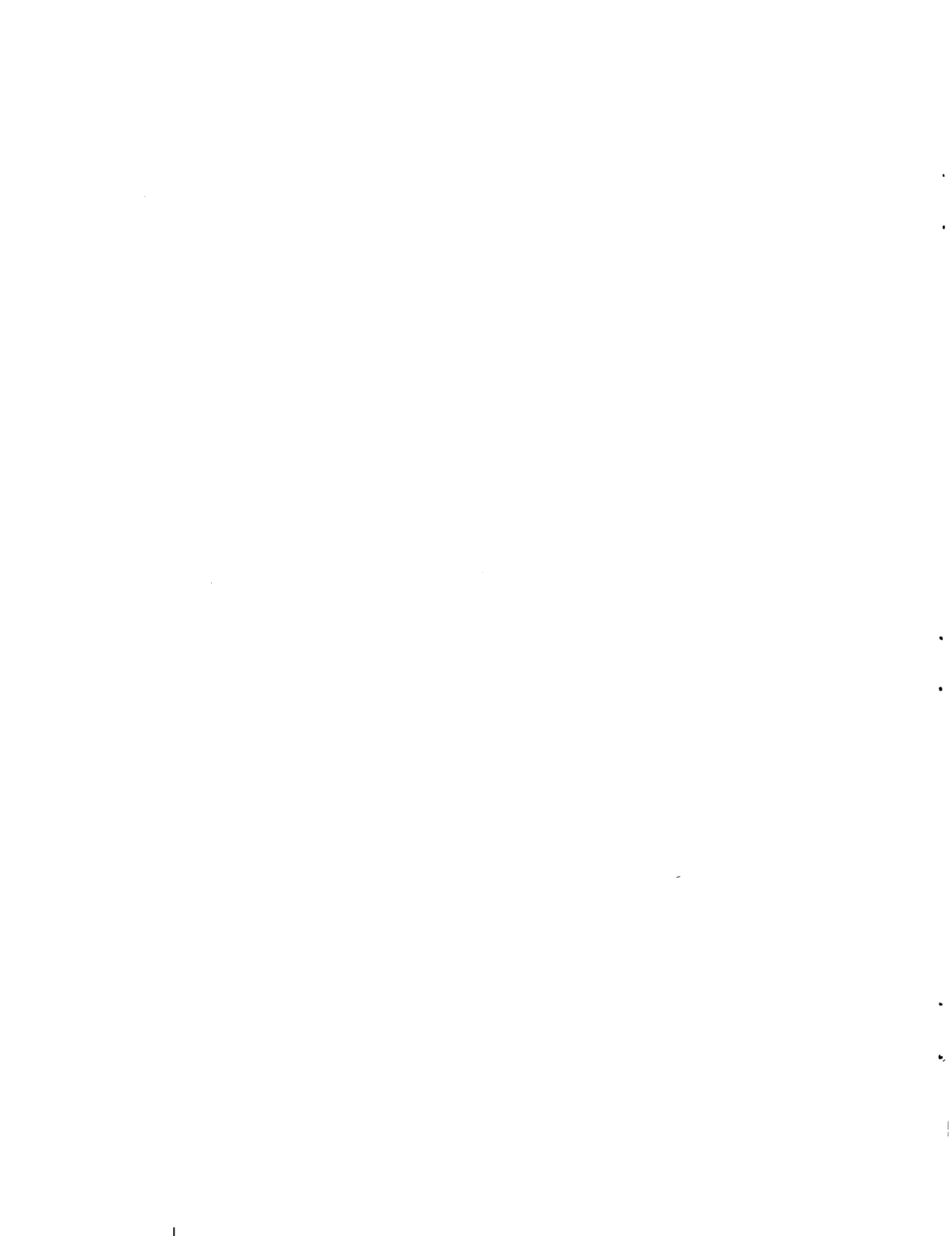

**ORIGINAL PAGE IS
OF POOR QUALITY**

PREFACE

In August and September of 1975, two Viking spacecraft were launched and subsequently cruised almost 500 million miles to Mars. A Viking Lander then separated from each spacecraft, soft landed on Mars in July and September of 1976, and conducted a number of scientific experiments. This report describes the system and subsystem performance of these Landers during the mission phases.

- I. INTRODUCTION AND SCOPE**
- II. MISSION DESCRIPTION**
- III. LAUNCH AND INTERPLANETARY CRUISE PHASE**
- IV. PRESEPARATION PHASE**
- V. SEPARATION THROUGH LANDING PHASE**
- VI. LANDED OPERATIONS**
- VII. EXTENDED MISSION**

On the cover:

The Mars photograph on the front and back covers was taken by Viking Lander 2 on September 26, 1976. It is a partial color panorama of the landing site. The colors accurately depict the Martian surface and sky, as indicated by the vivid colors of the United States flag. The high-gain antenna is shown in the upper center of the front cover; the radioisotope thermoelectric generator cover is shown on the back cover. The horizon is approximately 2 miles from the Lander.



CONTENTS

	Page
I. INTRODUCTION AND SCOPE	I-1
A. Program Goals	I-1
B. Viking Mission Plan	I-2
C. Viking Lander Configuration	I-5
D. Viking Lander Science	I-14 thru I-16
II. MISSION DESCRIPTION	II-1
A. Launch and Interplanetary Cruise	II-1
B. Mars Orbit Insertion to Separation	II-3
C. Separation through Landing	II-4
D. Landed Operations	II-7 and II-8
III. LAUNCH AND INTERPLANETARY CRUISE PHASE	III-1
A. Lander Subsystem Cruise Mode Performance	III-1
B. Battery Conditioning and Charging	III-6
C. Cruise Checkout	III-9
D. GCMS Vent, Bakeout, and Oven Characterization	III-11 and III-12
IV. PRESEPARATION PHASE	IV-1
A. Preseparation Checkout	IV-2
B. Preseparation Battery Charging	IV-7
C. Separation - 9.5 Hour Update	IV-8
D. Separation - 3.5 Hours to Separation	IV-8 and IV-9
V. SEPARATION THROUGH LANDING PHASE	V-1
A. Guidance and Control Subsystem	V-1
B. Communications Subsystem	V-4
C. Telemetry Subsystem	V-6
D. Power Subsystem	V-7
E. Propulsion Subsystem	V-9
F. Thermal Subsystem	V-9
G. Pyrotechnics Subsystem	V-10
H. Structures and Mechanisms Subsystem	V-10
I. Science Subsystem	V-11 and V-12

Preceding page blank

VI.	LANDED OPERATIONS	VI-1
A.	Guidance and Control Subsystem	VI-3
B.	Communications Subsystem	VI-4
C.	Telemetry Subsystem	VI-9
D.	Power Subsystem	VI-10
E.	Thermal Subsystem	VI-12
F.	Science Subsystem	VI-14
		thru
		VI-29
VII.	EXTENDED MISSION	VII-1
A.	Scope	VII-1
B.	Lander 1 Capabilities	VII-2
C.	Lander 2 Capabilities	VII-3
		and
		VII-4

Figure

I-1	Typical Lander Mission Sequence	I-3
I-2	Lander 1 and 2 Locations on Mars	I-4
I-3	Viking Lander Capsule	I-5
I-4	Lander Aeroshell	I-6
I-5	Lander Base Cover and Mortar Truss	I-6
I-6	Lander Body Equipment Plate, Top View	I-7
I-7	Lander Body Equipment Plate, Bottom View	I-7
I-8	Landed Configuration	I-8
I-9	Lander Functional Block Diagram	I-9
I-10	Lander Communications Links	I-11
II-1	Lander Separation-to-Entry Sequence	II-4
II-2	Lander Entry Sequence	II-4
II-3	Lander 1 Position on Mars	II-6
II-4	Lander 2 Position on Mars	II-6
II-5	First Image Taken on Surface of Mars, Lander 1, Footpad 3	II-6
II-6	First Panorama from Lander 1	II-6
II-7	First Image from Lander 2 Showing Footpad 3	II-7
II-8	First Panorama from Lander 2	II-7
III-1	Lander Cruise Phase Activities	III-1
III-2	Lander Launch Transient Internal Temperatures	III-3
III-3	Lander Launch Transient External Temperatures	III-3
III-4	Typical Lander Internal Temperatures for Battery Charging	III-4
III-5	Typical Lander Internal Temperatures for GCMS Bakeout	III-5
III-6	Typical Lander Internal Temperatures for Tape Recorder Maintenance	III-5
III-7	Battery Charge Cutoff Logic	III-7
III-8	Lander 1 RTG Transient Data for Cruise Checkout	III-7
IV-1	Preseparation Phase Timeline	IV-1
IV-2	Preseparation Sequence of Events	IV-1
IV-3	Lander Component Operation during Preseparation Checkout	IV-3
IV-4	Lander Loads during Preseparation Checkout	IV-7
IV-5	Battery Voltage during Preseparation Charging	IV-8

V-1	Lander 1 Relay Link Performance from Separation through Landing	V-5
V-2	Lander 1 Relay Link Performance from Entry through Landing	V-5
V-3	Telemetry Data Sequence from Separation through Touchdown	V-6
V-4	Separation through Landing Power Profile	V-7
V-5	Base Cover Inner Ring Entry Temperatures	V-10
V-6	Base Cover Outer Ring Entry Temperatures	V-10
VI-1	Lander 1 Primary Mission Activities	VI-2
VI-2	Lander 1 Reduced Mission Activities	VI-2
VI-3	Lander 2 Primary Mission Activities	VI-3
VI-4	Typical Direct Link Sequence	VI-4
VI-5	Typical S-Band Receiver Acquisition Sweep	VI-4
VI-6	Lander 1 Downlink Science Channel Signal-to-Noise Ratio	VI-6
VI-7	Lander 2 Command Channel Signal-to-Noise Ratio	VI-6
VI-8	Typical Lander 1/Orbiter 1 Relay Link	VI-6
VI-9	Typical Lander 2/Orbiter 2 Relay Link	VI-8
VI-10	Typical Lander 2/Orbiter 1 Relay Link	VI-8
VI-11	Lander Power Profile during Busy Sol	VI-11
VI-12	Lander 1 Primary Mission Internal Temperature Ranges	VI-13
VI-13	Lander 2 Primary Mission Internal Temperature Ranges	VI-13
VI-14	Landed TWTA Temperatures	VI-13
VI-15	Landed UHF Transmitter Temperatures	VI-13
VI-16	Typical Landed Temperature Profiles	VI-14
VI-17	Schematic of Lander 1 Sampling Area Summarizing Nominal Mission Surface Sampler Activities	VI-24
VI-18	Schematic of Lander 2 Sampling Area Summarizing Nominal Mission Surface Sampler Activities	VI-25
VII-1	Lander 2 Environmental Predictions	VII-3

Table

I-1	Viking Lander Science Experiments	I-14
II-1	Major Lander Separation through Landing Events	II-4
III-1	Lander 1 Battery Discharge Voltage Following Launch	III-1
III-2	Cruise Coast Temperatures	III-3
III-3	Lander 1 Initial Battery Charge	III-6
III-4	Lander 2 Initial Battery Charge	III-6
III-5	Lander 1 Final Battery Conditioning	III-8
III-6	Lander 2 Final Battery Conditioning	III-8
III-7	Science Instrument Operation during Cruise Checkout	III-10
III-8	Meteorology Checkouts during Cruise Phase	III-11
III-9	Lander 1 GCMS Cruise Operations	III-11
III-10	Lander 2 GCMS Cruise Operations	III-12
IV-1	Entry Science Instrument Operation during Preseparation Checkout	IV-4
IV-2	Actual Battery Charge Times	IV-7
V-1	Observed Attitudes and Rates during Deorbit Burn	V-1
V-2	Estimated Conditions at Entry	V-1
V-3	Entry High Altitude Performance	V-2
V-4	Maximum Observed Attitude Rates during Aerodynamic Entry	V-2
V-5	Conditions Observed at Parachute Deployment	V-2
V-6	Entry Loads and Heating Results	V-2

V-7	Initial Errors after Aeroshell Separation	V-3
V-8	Reconstructed Conditions, End of Parachute Phase	V-3
V-9	Maximum Observed Conditions at the Tip Up Maneuver	V-4
V-10	Maximum Dynamic Conditions at Touchdown	V-4
V-11	Final Landing Positions	V-4
V-12	Viking Lander Loads	V-8
V-13	RCS/Deorbit Propellant Usage Summary	V-9
V-14	Terminal Descent Propellant Usage Summary	V-9
V-15	Lander Pyrotechnic Functions	V-10
V-16	Landing Leg Operation	V-11
V-17	Entry Science Sequence of Events	V-12
VI-1	Lander 1 Power Subsystem Performance	VI-10
VI-2	Lander 2 Power Subsystem Performance	VI-10
VI-3	Lander 1 Biology Activities	VI-15
VI-4	Lander 2 Biology Activities	VI-15
VI-5	Lander 1 GCMS Activities	VI-17
VI-6	Lander 2 GCMS Activities	VI-17
VI-7	Lander 1 XRFS Operation and Performance	VI-18
VI-8	Lander 2 XRFS Operation and Performance	VI-18
VI-9	Lander 1 Camera Scan Verification and Dust Sequences	VI-19
VI-10	Lander Camera Elevation Scan Cycles	VI-20
VI-11	Lander 1 Surface Sampler Performance Summary	VI-23
VI-12	Lander 2 Surface Sampler Performance Summary	VI-28
VII-1	Lander 1 Landed Mission Hardware Failures	VII-3
VII-2	Backup Hardware Status	VII-3
VII-3	Lander 2 Landed Mission Hardware Failures	VII-3

GLOSSARY

AA-F	Atmospheric Analysis Filtered	MRO	Memory Readout
AA-U	Atmospheric Analysis Unfiltered	OA	Organic Analysis
AE	Atmospheric Enrichment	PC	Proportional Counter
AFA	Atmospheric Filter Assembly	PCDA	Power Conditioning and Distribution Assembly
BPA	Bioshield Power Assembly	PDA	Processor and Distribution Assembly
bps	bits per second	RA	Radar Altimeter
CFAR	Constant False Alarm Rate	RAE	Radar Altimeter Electronics
DAPU	Data Acquisition and Processing Unit	RCE	Relay Communications Equipment
DCS	Direct Communications System	RCS	Reaction Control Deorbit System
DSM	Data Storage Memory	RPA	Retarding Potential Analyzer
DSN	Deep Space Network	RSL	Received Signal Level
ERT	Earth Receive Time	RTG	Radioisotope Thermoelectric Generator
G&C	Guidance and Control	SSCA	Surface Sampler Control Assembly
GCA	Gas Chromatograph Assembly	SOC	State-of-Charge
GCMS	Gas Chromatograph Mass Spectrometer	TD	Terminal Descent
GCSC	Guidance Control and Sequencing Computer	TDLR	Terminal Descent and Landing Radar
HGA	High-Gain Antenna	TR	Tape Recorder
ICL	Initial Computer Load	TSEP	Time of Separation
IRU	Inertial Reference Unit	TWTA	Traveling Wave Tube Amplifier
JPL	Jet Propulsion Laboratory	UAMS	Upper Atmosphere Mass Spectrometer
kbps	kilobits per second	UHF	Ultra High Frequency
KSC	Kennedy Space Center	VCSF	Viking Control and Simulation Facility
LPCA	Lander Pyrotechnic Control Assembly	VDA	Valve Drive Amplifier
LSO	Lander Support Office	XRFS	X-Ray Fluorescence Spectrometer
LTEMP	Lander Thermal Model Software		
MEA	Meteorology Electronics Assembly		
MOI	Mars Orbit Insertion		

I. INTRODUCTION AND SCOPE

- A. Program Goals
- B. Viking Mission Plan
- C. Viking Lander Configuration
- D. Viking Lander Science

**ORIGINAL PAGE IS
OF POOR QUALITY**

The scars on the Martian surface at the extreme left resulted from trenches dug by the surface sampler shown protruding from Lander 1 on the right. The magnet cleaning brush is shown in the lower left portion of this photograph.

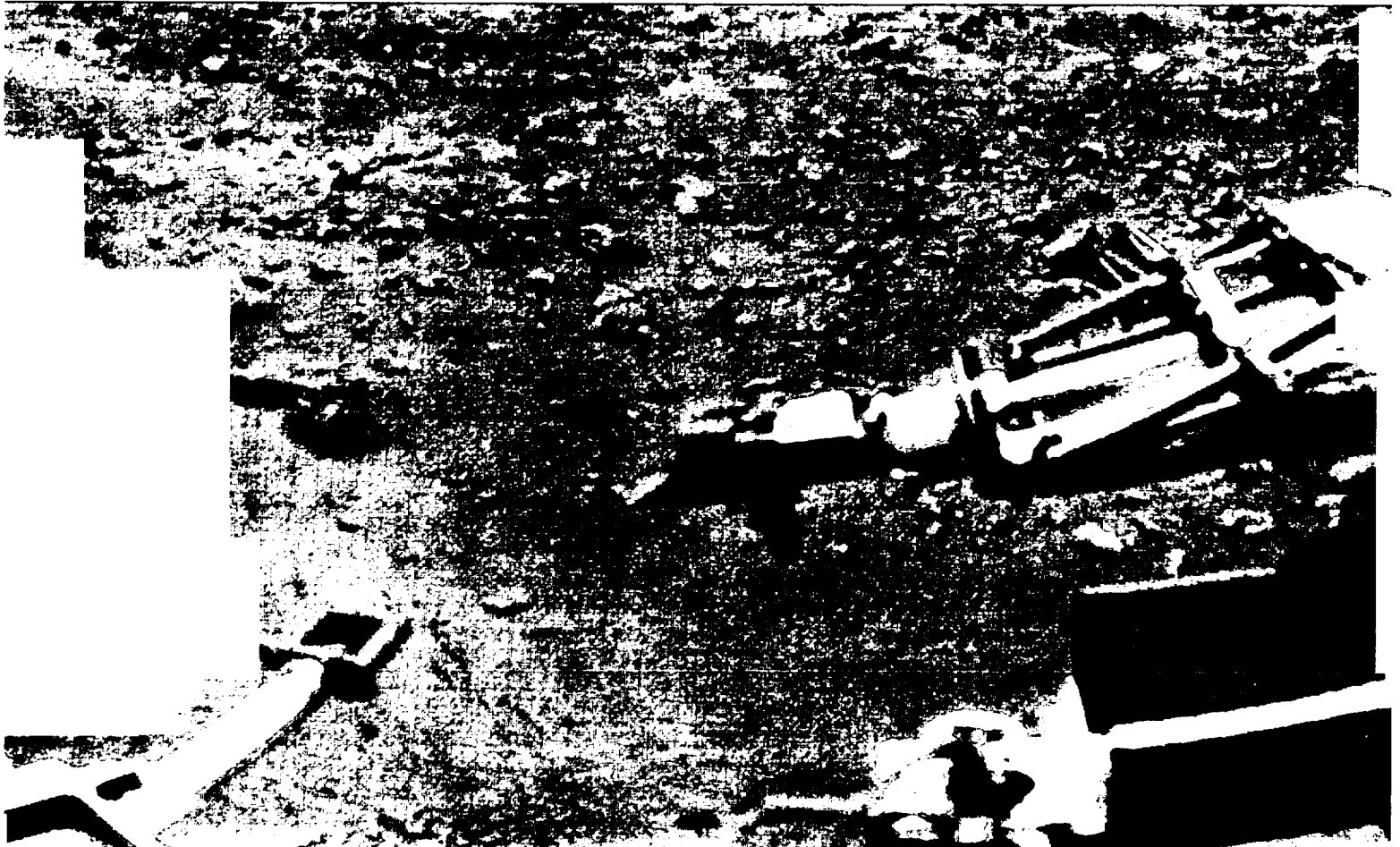

I. INTRODUCTION AND SCOPE

This report summarizes Viking Lander hardware performance during launch, interplanetary cruise, Mars orbit insertion, preseparation, separation through landing, and the primary landed mission. The primary emphasis is on Lander engineering and science hardware operations, not the results of the scientific investigations conducted during the mission phases. The Viking Lander science results are reported in the June 1977 issue of *The Journal of Geophysical Research*. Detailed information concerning Lander hardware operation from separation through landing may be found in *Entry Data Analysis for Viking Landers 1 and 2* (TN-3770218), Martin Marietta Corporation, December 1976.

This report is divided into two primary parts. Chapter II contains a fairly detailed description of the "as-flown" mission, particularly with respect to Lander system performance and anomalies. Chapters III through VI detail the Lander subsystem hardware performance during the various mission phases. The casual reader should find sufficient information in Chapter II. More detailed performance data may be found in the remaining chapters. Chapter VII is a brief description of the extended mission and predicted Lander performance.

The remainder of this introduction describes the Viking goals, mission plan, and Lander physical description and subsystem definition. This allows the reader to better understand mission performance without referencing other documents. Detailed information concerning the Lander design and capabilities may be found in *Viking Lander "As-Built" Performance Capabilities*, and *Spacecraft Operations Handbook* (HB-3720311).

The following personnel contributed directly to the preparation of this report:

R. Bender	C. Green	D. Rushneck
J. Berry	T. Knight	C. Seese
A. Castro	H. Kowitz	W. Smeton
K. Farley	O. Moore	J. Speicher
R. Frank	C. Rea	P. Stafford
M. Griffin		

In addition to data returned from the Orbiters and Landers, data were extracted from the following documents to prepare this report:

Viking Lander As-Built Performance Capabilities. Martin Marietta Corporation, 1976.

"From Separation to Touchdown: The Performance of Lander Capsules." AIAA presentation, John D. Goodlette, 1977.

Viking 1 Early Results. NASA SP-408. 1976.

Entry Data Analysis for Viking Landers 1 and 2. TN-3770218. Martin Marietta Corporation, 1976.

Viking 75 Project Summary of Primary Mission Surface Sampler Operations. NASA-VFT-019. 1977.

A. PROGRAM GOALS

The objective of the Viking mission is to advance significantly the "... knowledge of the planet Mars by means of observations from Martian orbit and direct measurements in the atmosphere and on the surface. Particular emphasis (is to) be placed on obtaining biological, chemical, and environmental data relevant to the existence of life on the planet at this time or at some time in the past, or the possibility of life existing at a future date."

By observing the physical and chemical composition of the atmosphere; the daily and seasonal changes in wind, temperature, pressure, and water vapor content near the surface; and the texture of surface materials, their organic and inorganic composition, and some of their physical properties, the Viking mission is enabling scientists to define the present conditions under which any Martian biological processes would have to take place. In addition, both Landers have collected and will continue to collect direct evidence as to whether biological processes are now occurring.

The Viking mission is providing information that will lead toward an eventual understanding of the history of Mars. Visual imagery and infrared observations of the surface from orbit are revealing the geologic processes that have shaped the planet's surface features. They can also indicate past alterations in the composition of the atmosphere and the surface materials. Such information is, of course, relevant to the questions of Mars' evolution as a planet, as well as to bio-organic evolution. This information is also pertinent to the development of

our understanding of Earth's place in the history of the solar system.

Unlike earlier ventures in planetary exploration, Viking offers investigators the new dimension of simultaneous Orbiter and Lander observation. The added value is immense. Simultaneity gives a chance to relate observations on a global scale with findings tied to a spot on the surface. The viewpoint and scale are so different as to stretch the investigators' imaginations. Infrared temperature measurements from the Orbiters indicate a freezing of part of the atmosphere onto the South Polar Cap; and at the same time, a sensor on Lander 1 at Chryse Planitia feels the reduction of atmospheric mass. Sometimes the viewpoints are so far apart they are hard to reconcile. The Orbiters see places where low lying fogbanks of water ice appear and dissipate daily, while the Lander's biology instrument sees surface particles that react almost violently to a whiff of water vapor. Plainly Mars is nonuniform; it will take many, many hours of analysis and thought to understand the millions of bits of data returned from Mars.

B. VIKING MISSION PLAN

Two identical Viking spacecraft, each consisting of an Orbiter and a Lander, were launched from Kennedy Space Center on a Titan III/Centaur from Launch Complex 41. Viking 1 (Orbiter 1/Lander 1) was launched August 20, 1975 and Viking 2 (Orbiter 2/Lander 2) was launched September 9, 1975. With a second firing of the Centaur engine the Viking spacecraft were injected into trans-Mars trajectories. Just after the cruise to Mars began, the spacecraft separated from the Centaur, and the Orbiters then deployed antennas and solar panels and acquired the sun and the bright star Canopus for navigation. During cruise, the Orbiters were the primary operating portions of the spacecraft, supplying power to the Landers, maintaining proper attitude for communication to Earth and thermal balance, commanding Lander checkouts and operations, and relaying Lander data to Earth for analysis of Lander hardware status. The Orbiters also performed midcourse maneuvers to insure that the spacecraft arrived at Mars at the right time and the right place.

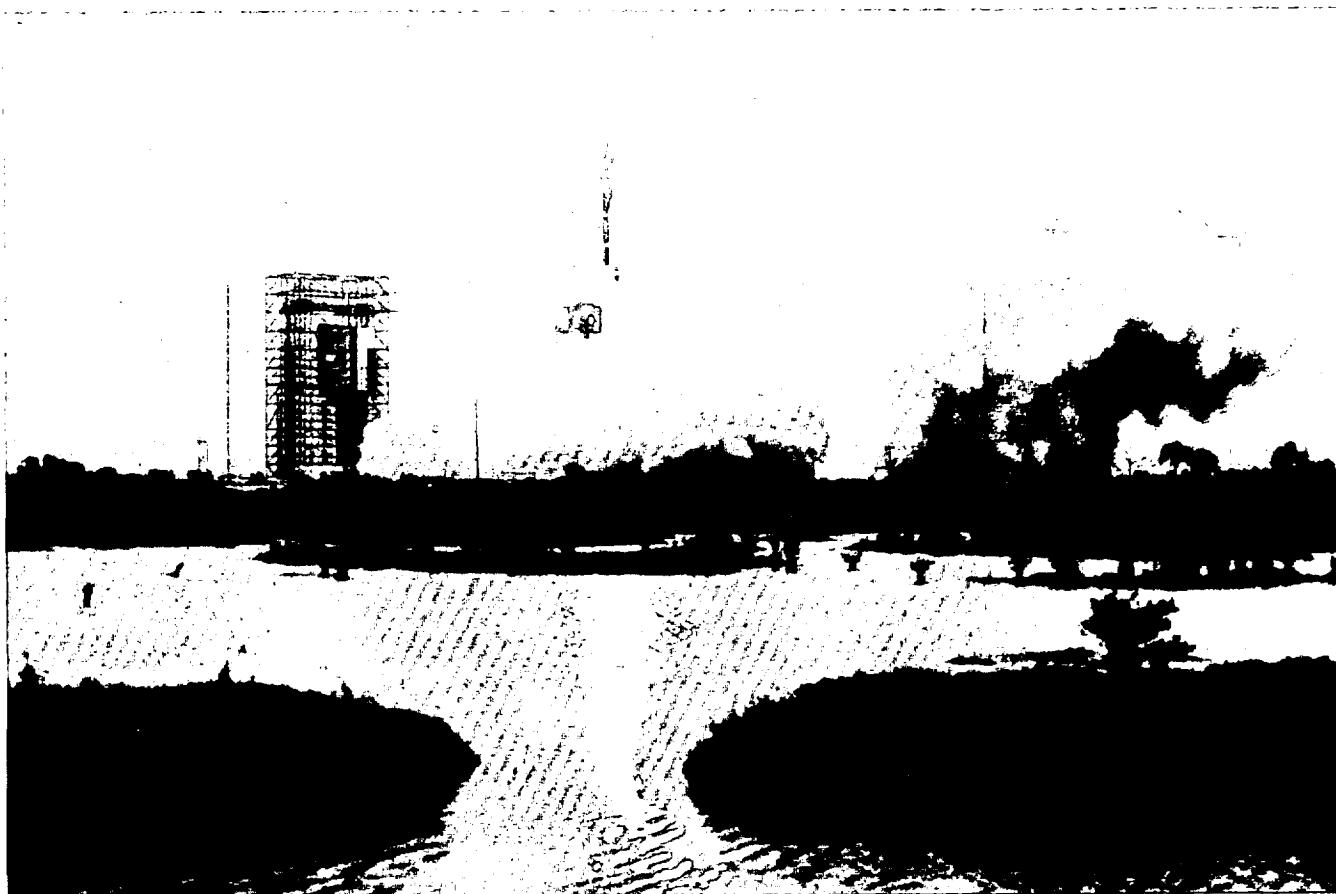

Viking 1 Launch from Kennedy Space Center, August 20, 1975

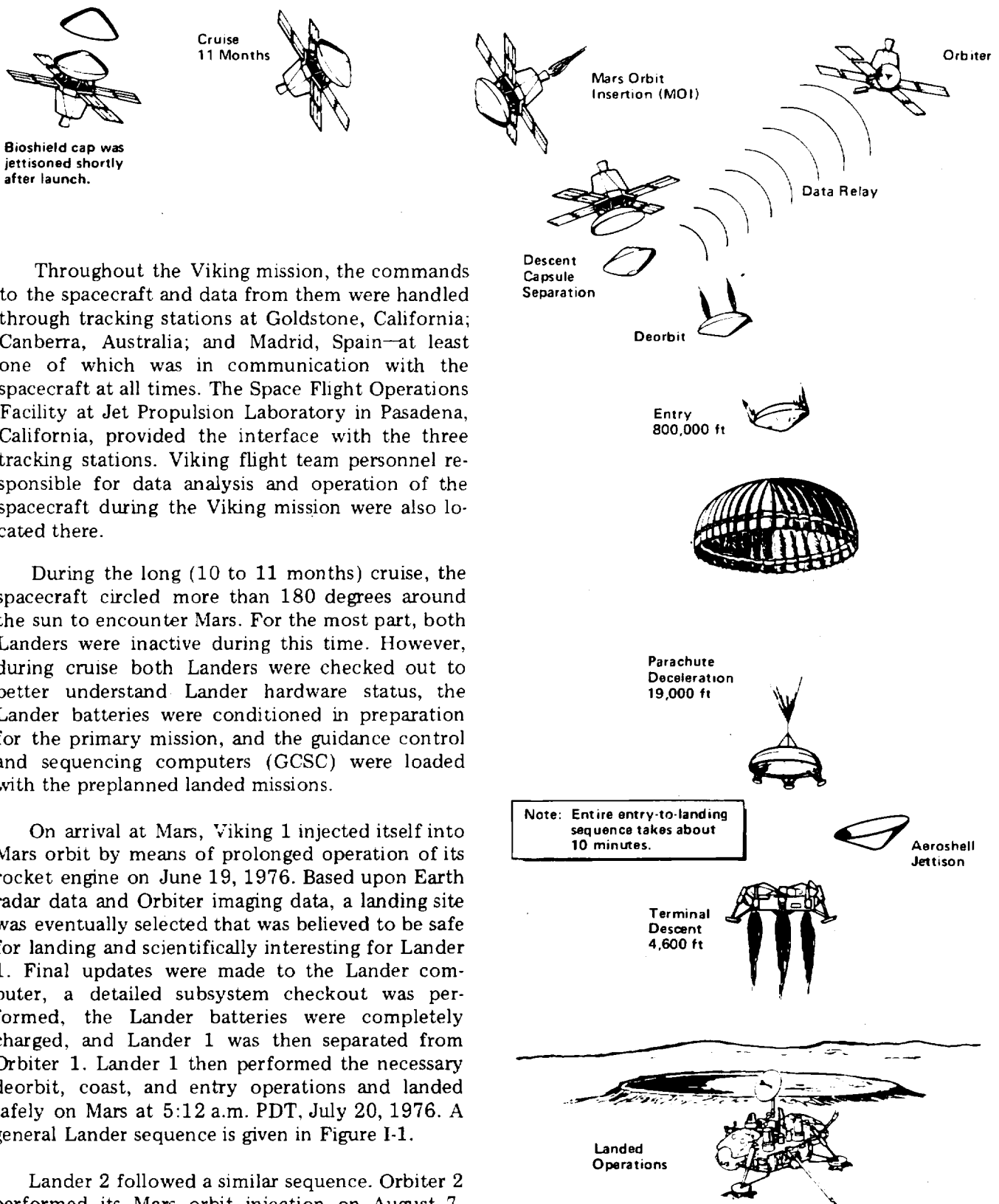

Bioshield cap was jettisoned shortly after launch.

Cruise 11 Months

Mars Orbit Insertion (MOI)

Orbiter

Descent Capsule Separation

Data Relay

Deorbit

Entry 800,000 ft

Parachute Deceleration 19,000 ft

Note: Entire entry-to-landing sequence takes about 10 minutes.

Aeroshell Jettison

Terminal Descent 4,600 ft

Landed Operations

Throughout the Viking mission, the commands to the spacecraft and data from them were handled through tracking stations at Goldstone, California; Canberra, Australia; and Madrid, Spain—at least one of which was in communication with the spacecraft at all times. The Space Flight Operations Facility at Jet Propulsion Laboratory in Pasadena, California, provided the interface with the three tracking stations. Viking flight team personnel responsible for data analysis and operation of the spacecraft during the Viking mission were also located there.

During the long (10 to 11 months) cruise, the spacecraft circled more than 180 degrees around the sun to encounter Mars. For the most part, both Landers were inactive during this time. However, during cruise both Landers were checked out to better understand Lander hardware status, the Lander batteries were conditioned in preparation for the primary mission, and the guidance control and sequencing computers (GCSC) were loaded with the preplanned landed missions.

On arrival at Mars, Viking 1 injected itself into Mars orbit by means of prolonged operation of its rocket engine on June 19, 1976. Based upon Earth radar data and Orbiter imaging data, a landing site was eventually selected that was believed to be safe for landing and scientifically interesting for Lander 1. Final updates were made to the Lander computer, a detailed subsystem checkout was performed, the Lander batteries were completely charged, and Lander 1 was then separated from Orbiter 1. Lander 1 then performed the necessary deorbit, coast, and entry operations and landed safely on Mars at 5:12 a.m. PDT, July 20, 1976. A general Lander sequence is given in Figure I-1.

Lander 2 followed a similar sequence. Orbiter 2 performed its Mars orbit injection on August 7, 1976. A suitable landing site was selected, pre-separation and separation activities occurred exactly as scheduled, and Lander 2 landed safely on Mars at

Figure I-1 Typical Lander Mission Sequence

3:58 p.m. PDT on September 3, 1976. Figure I-2 shows the location of the landing sites of both Landers.

The primary landed missions of both Landers were completed with outstanding success, returning data of excellent quality and quantity. On November 25, 1976, Mars and Earth were in conjunction—lined up on opposite sides of the sun. This caused communication between Earth and the spacecraft to be interrupted for about 30 days and signaled the end of the primary landed missions. Both Landers and Orbiters were supplied with sufficient information to continue without Earth communications during this time at a reduced activity level. All spacecraft survived this blackout in satisfactory condition and will continue with extended mission operations for approximately 18 months.

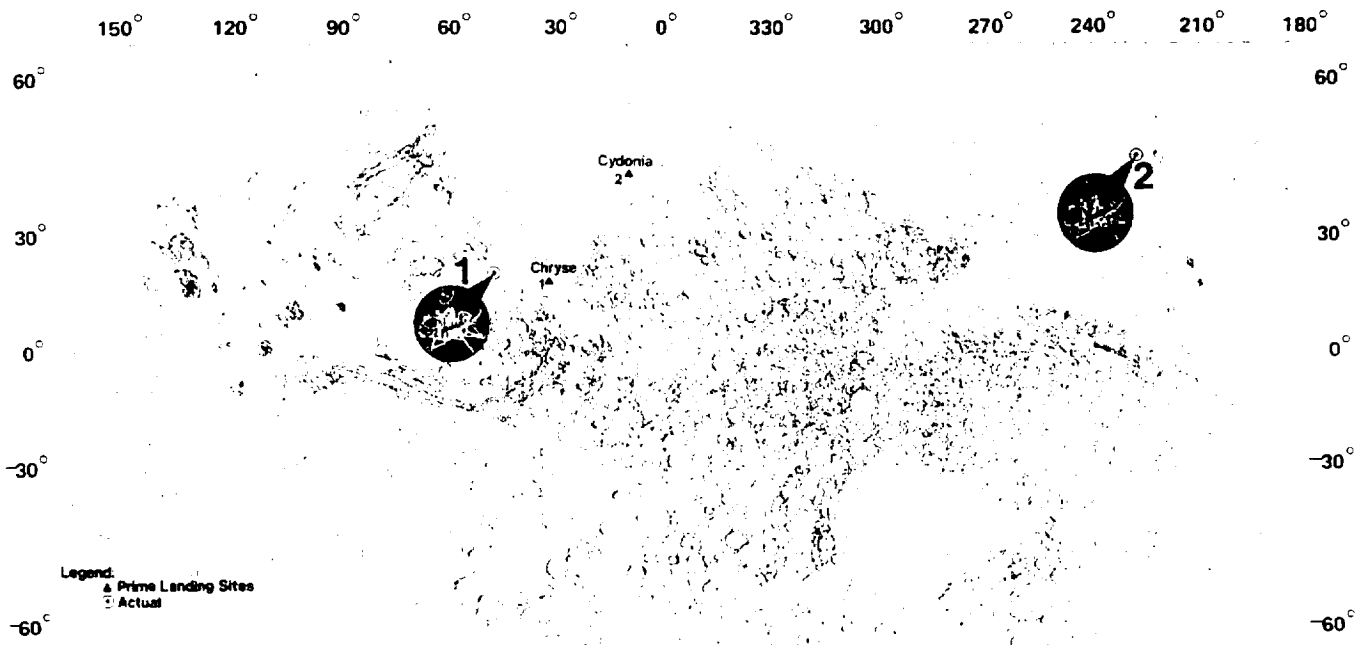
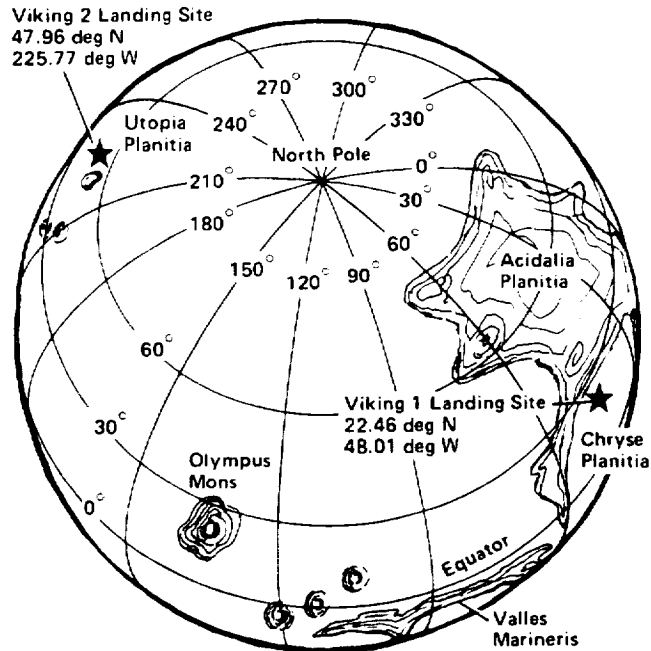

Figure I-2 Lander 1 and 2 Locations on Mars

ORIGINAL PAGE IS
OF POOR QUALITY

C. VIKING LANDER CONFIGURATION

Figure I-3 is an exploded view of the Viking Lander capsule. The Lander is doubly encapsulated within the bioshield and the descent capsule. The bioshield, the two-piece outer capsule, consists of a base and cap which protects the sterilized descent capsule from biological, chemical, and particulate contamination before and during launch. The bioshield cap was jettisoned shortly after launch. In Mars orbit, the descent capsule separates from the bioshield base.

The descent capsule consists of the aeroshell, base cover, and Lander. This section describes the contents of each Lander subsystem and the primary functions of each subsystem. The location of these subsystem components and a more detailed physical configuration is shown in Figures I-4 through I-8. The functional relationship of the Lander subsystems is shown in Figure I-9.

1. Guidance and Control (G&C) Subsystem

The G&C subsystem consists of the guidance control and sequencing computer (GCSC), flight software, inertial reference unit (IRU), radar altimeters (RA), terminal descent and landing radar (TDLR), and valve drive amplifier (VDA). All components are mounted external to the Lander body except for the GCSC. The GCSC and resident flight software receive all G&C sensor data, process the data, and issue all control commands including those to the VDA for propulsion control.

The inertial reference unit (IRU) is a strap-down sensor system with three principal gyros and accelerometers. There is a redundant fourth gyro skewed equally with respect to the principal axes, and a redundant fourth accelerometer in the critical X-axis. Of these, three gyros and three accelerometers are selected for descent and entry by the flight team from the prepreparation checkout data. These sensors provide data to software algorithms in the GCSC to calculate vehicle attitude, attitude rates, velocity, and altitude. Immediately after landing, the IRU provides Lander orientation data and is then shut down for the remainder of the mission.

There are two redundant sets of radar altimeter (RA) electronics; each is connected through a radio frequency switch to one antenna located on the aeroshell and one located on the Lander body. The RA uses four modes to determine altitude from

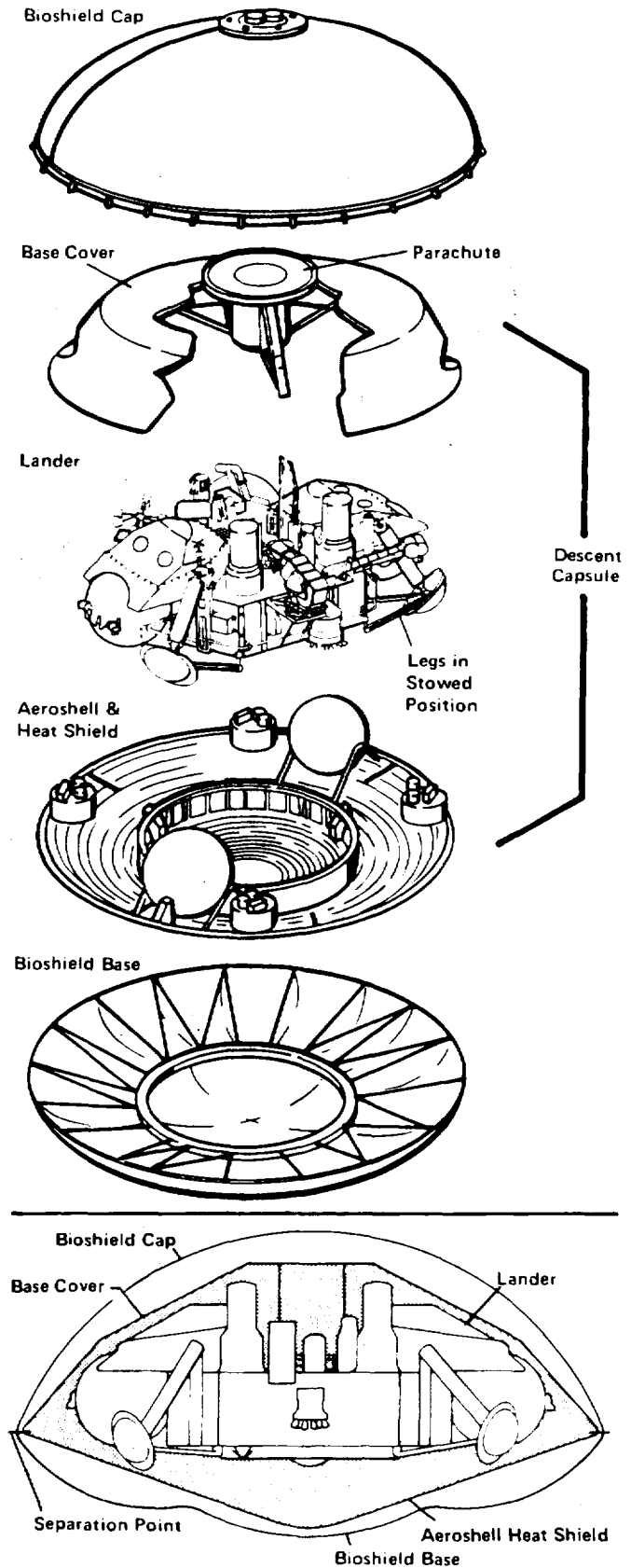

Figure I-3 Viking Lander Capsule

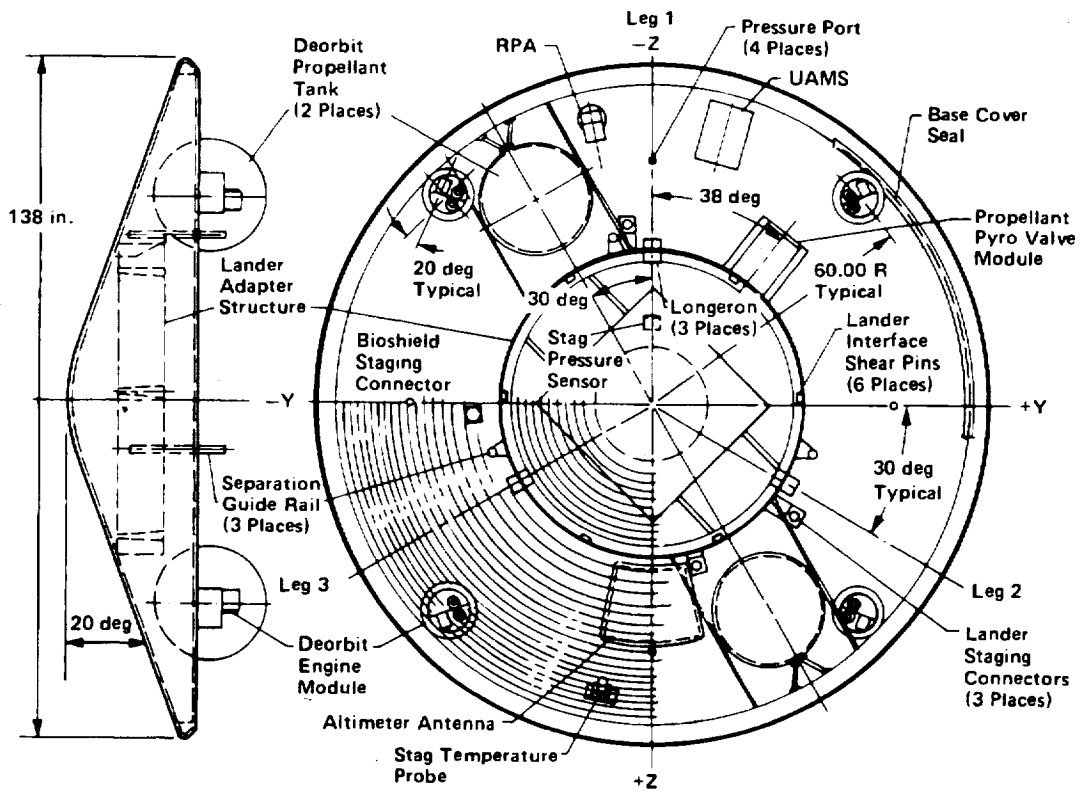

Figure I-4 Lander Aeroshell

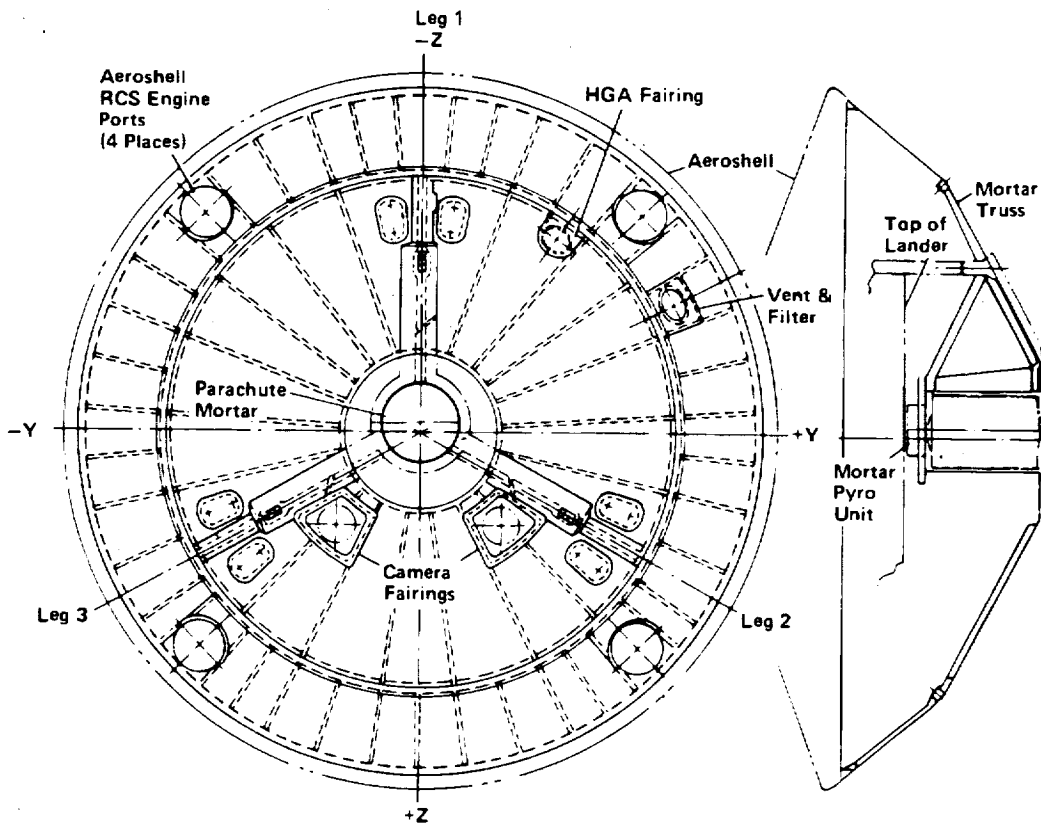

Figure I-5 Lander Base Cover and Mortar Truss

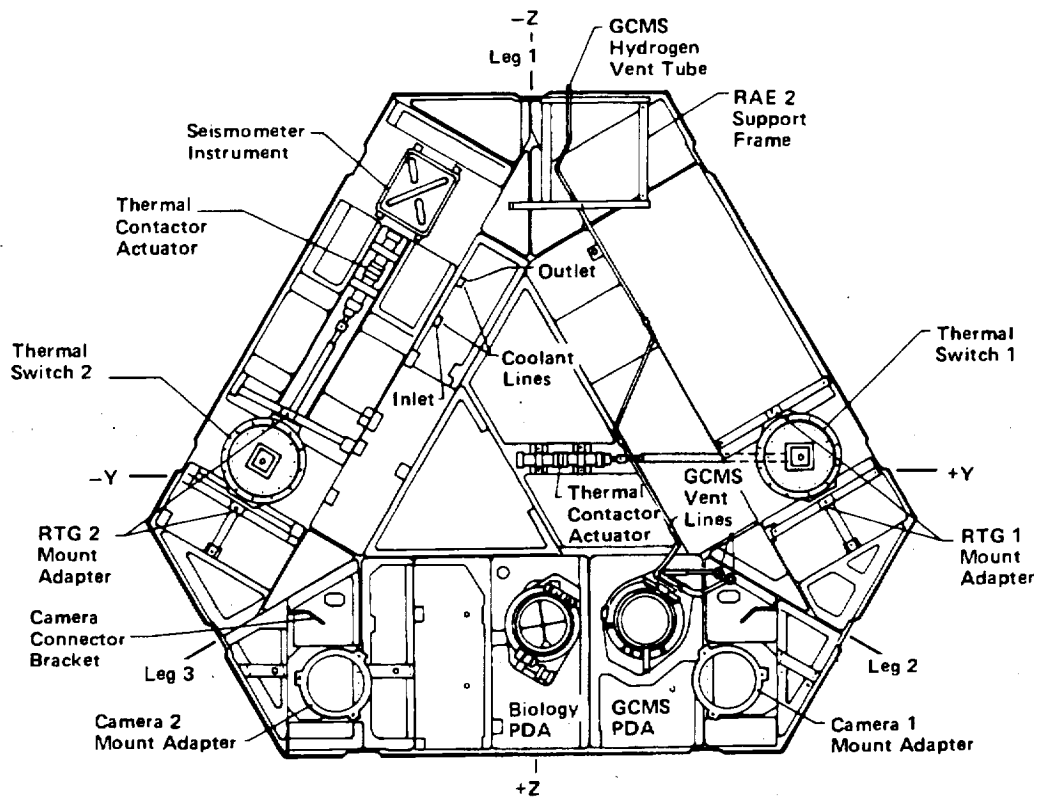

Figure I-6 Lander Body Equipment Plate, Top View

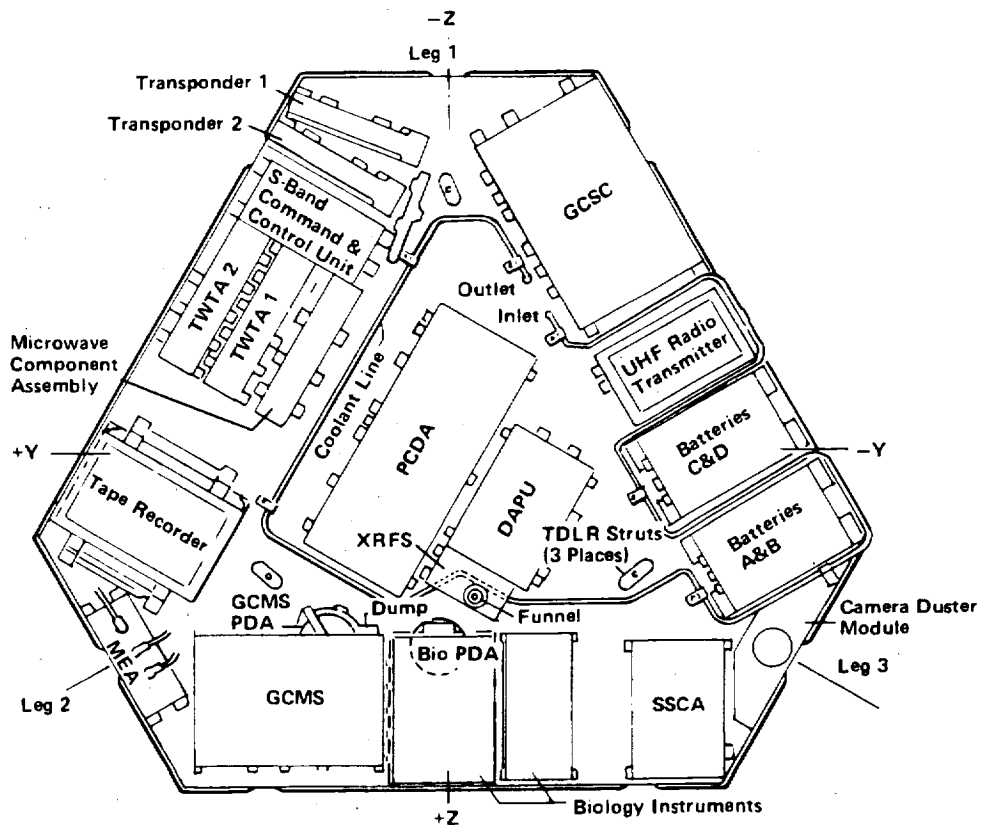

Figure I-7 Lander Body Equipment Plate, Bottom View

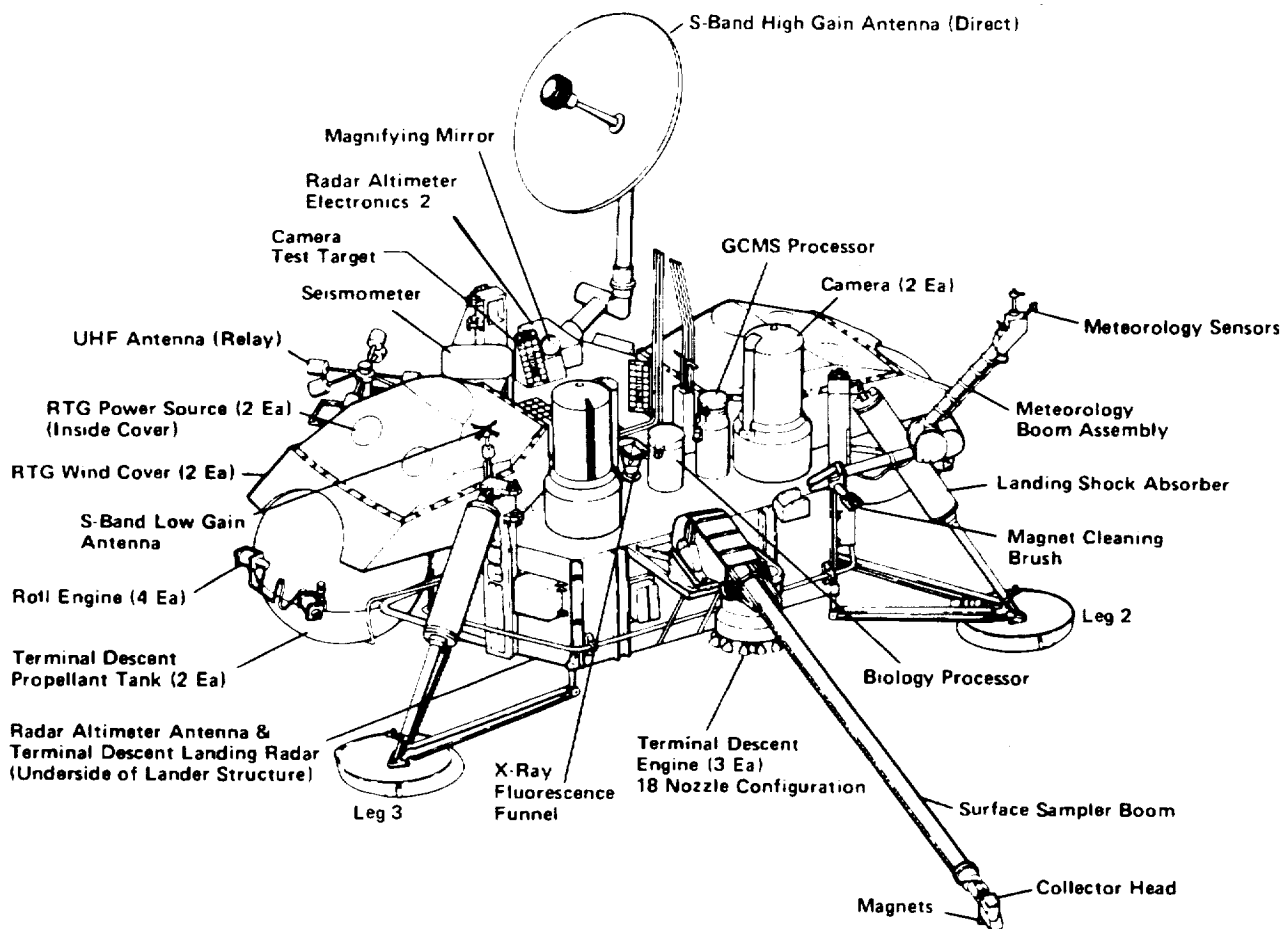

Figure 1-8 Landed Configuration

450,000 ft to 135 ft. The RA is turned on at the entry point of 800,000 ft and turned off after landing. The RA data are required to null navigator altitude errors due to varying terrain heights along the flight path.

The terminal descent and landing radar (TDLR) is a velocity radar with four independent Doppler radars integrated in one unit. The radars measure the respective beam velocity relative to the planet's surface. GCSC software algorithms convert these data to principal-axis velocities smoothed with IRU data. The TDLR is turned on subsequent to aeroshell separation and provides data through touchdown. There are two modes of operation dictated by altitude region. Any three of the four radar channels are sufficient to determine principal-axis velocity.

The valve drive amplifier (VDA) decodes and implements GCSC commands for the reaction control engines, terminal descent engines, and terminal

roll thrusters. The VDA circuitry is redundant (quadruply redundant in some cases) and internally partitioned so portions of the component are powered on from separation through touchdown.

The GCSC is a block redundant, random access, customized, general-purpose computer. The GCSC interfaces with all Lander subsystems and its functional tasks are: (1) power management of all Lander components; (2) command and sequencing for science, communications, and data handling; (3) uplink command decoding and subsequent processing; (4) guidance, steering, and control of the Lander from separation to landing; and (5) computation of the Lander orientation and S-band antenna pointing after landing. Each GCSC has two strings (referred to as side A and side B) with each string containing a 18,432 word memory, processor, input/output circuitry, and power supply. One side is selected prior to separation and used through landing. After landing, circuitry is enabled that automatically allows switchover to the other GCSC side if certain malfunctions occur.

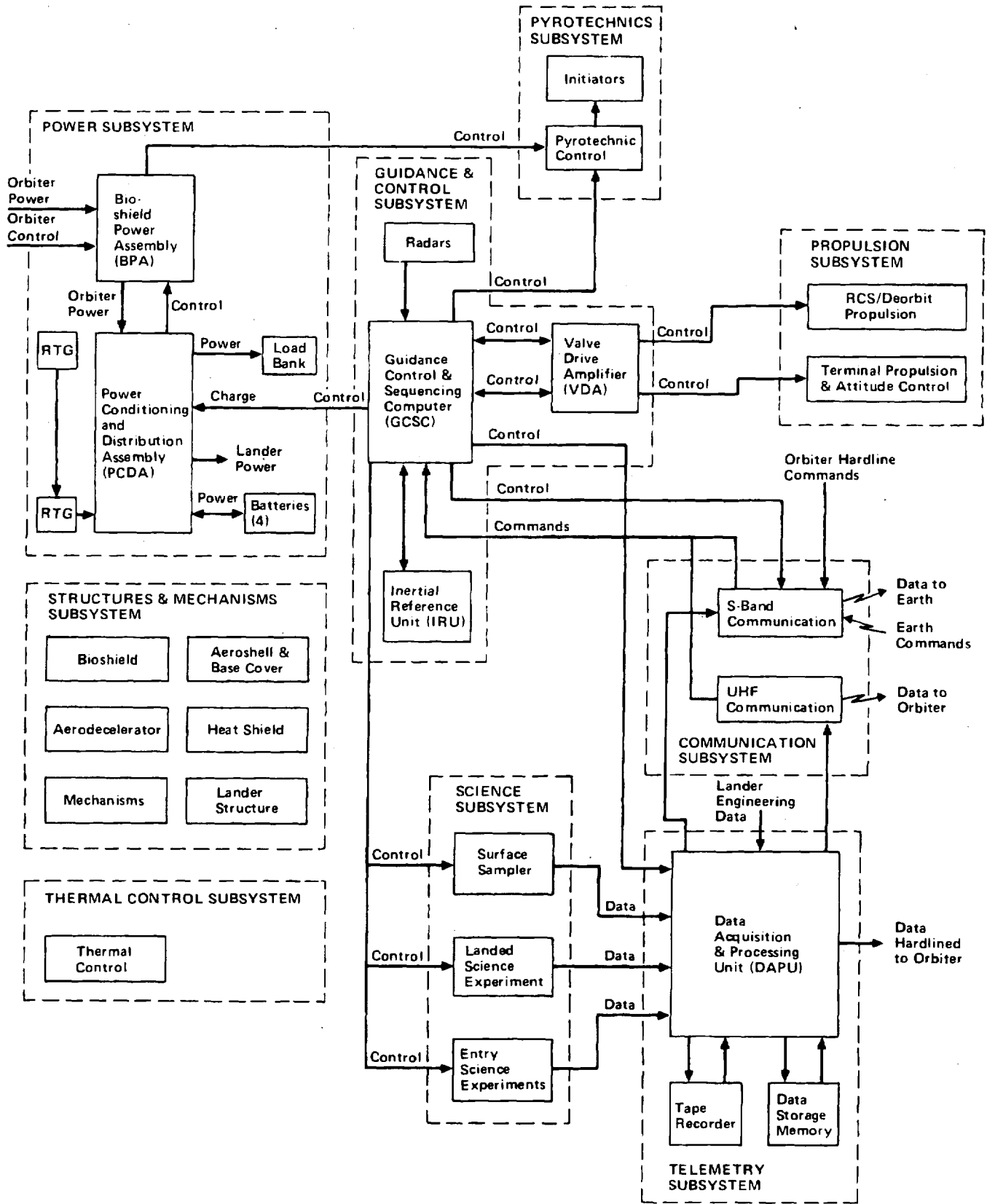

Figure I-9 Lander Functional Block Diagram

The GCSC memory contains the software (flight program) that provides the capability to control Lander functions from prelaunch through the duration of the landed mission. The flight program consists of an operating system known as the flight executive and a set of user application programs to control specific mission phases/operations. The flight program is redundant in that it resides in both sides of the GCSC. However, these sides are independent of each other and there is no computer-to-computer communication. Before separation from the Orbiter, the sequences in the flight program to perform battery conditioning, Lander checkout and calibration, flight program updates, and separation from the Orbiter are initiated by commands from the flight team via the Orbiter. On separation from the Orbiter, navigation, guidance, steering, and control are performed by the flight program. Using sensor data, the propulsion outputs necessary for deorbit, entry, terminal descent, and landing are calculated and commanded. During descent, the flight program also controls all other Lander functions including science experiments, telemetry operations, and pyrotechnic operations. At landing, the flight program initiates landed operations through use of a prestored mission. The flight team controls the Lander functions by updating events in this mission and their associated control parameters. These scheduled events include landed science experiments, relay communications, and direct communications.

2. Power Subsystem

The power subsystem consists of the bioshield power assembly (BPA), the power conditioning and distribution assembly (PCDA), batteries, radioisotope thermoelectric generators (RTG), and two load banks.

The BPA is located on the bioshield base and is internally block redundant. This unit serves three purposes: to regulate and distribute Orbiter-supplied power used by Lander components during cruise and Mars orbit; to charge the Lander batteries; and to provide interface circuitry for Orbiter-to-Lander commands, data, and control before separation.

The PCDA provides several functions and is internally block redundant. The PCDA decodes GCSC commands and in turn switches the 114 electrical loads on and off. The RTG energy, delivered at 8.8 volts, is converted to a nominal 28

volts by the PCDA. The RTGs are switched by the PCDA either to load bank resistors, Lander loads, or battery charging. Redundant sentry timers in the PCDA are clocks that are reset by the GCSC every 60 sec and are used to determine that a computer may have failed and signals for a switchover to the other computer in the absence of a 60-sec reset. The PCDA contains redundant undervoltage sensors to preclude complete discharge of the batteries by initiating an emergency sequence to decrease the bus load. These capabilities are enabled only after landing. There are four 24-cell nickel-cadmium batteries, each with a storage capacity of approximately 8 A-hr.

The two RTGs are located on top of the Lander under protective wind covers. The RTGs serve both as an electrical and thermal energy source for the Lander. As an electrical source, they provide at least 60 watts at the PCDA equipment bus through the end of mission at 28 volts (they presently are providing approximately 70 watts with very slow degradation); as a thermal source, they can deliver up to 120 watts of heat to the Lander body interior through the thermal switches.

3. Telemetry Subsystem

The telemetry subsystem acquires, processes, stores, and modulates all Lander science and engineering data for transmission during launch, cruise, pre-separation, deorbit, entry, descent, and landed activities. The telemetry subsystem contains a data acquisition and processing unit (DAPU), tape recorder (TR), and data storage memory (DSM). The telemetry interface is to the GCSC, science instruments, communications, hardline to the Orbiter (during cruise), and with almost all Lander engineering hardware to allow acquisition of Lander engineering data.

The DAPU has the capability of being commanded by the GCSC into over 200 modes. Data are received at 0.25-, 0.5-, 1-, 2-, 4-, and 16-kbps rates. These data can be stored in the DSM or tape recorder or routed directly to the communications subsystem. The DAPU acquires and formats data from 120 low-level (0 to 40 mV) analog channels, 64 high-level (0 to 5 V) analog channels, 48 bilevel (0 or 5 V) channels, and 15 serial digital sources.

In addition to acquisition and direct transmission or storage of GCSC and science data, the DAPU uses seven basic data formats:

- 1) Format 1—Used for engineering data during cruise.
- 2) Format 2—Collects engineering, science, and GCSC data from separation through deorbit burn and sensing of 0.05 g plus 7 sec to parachute deployment plus 6.5 sec. Data are transmitted in real time and interleaved with data stored in the DSM for 60 sec.
- 3) Format 2A—Real-time engineering, GCSC, and science data from completion of deorbit burn to sensing of 0.05 g plus 7 sec.
- 4) Format 2P—Used during preseparation check-out and is identical to Format 2 except for GCSC content.
- 5) Format 3—Engineering, GCSC, and science data from parachute deployment plus 6.5 sec to landing.
- 6) Format 4—Used for periodic collection and storage of engineering and science data during the landed phase.
- 7) Format 5—Real-time engineering and science data collected during the landed phase.

The tape recorder has a storage capacity of 10 million bits on each of four tracks. The tape material is a phosphor-bronze base coated with nickel cobalt and is 1-mil thick and 700-ft long. Recording speeds are 4 and 16 kbps and playback rates are 0.25, 0.5, 1.4, and 16 kbps. The DSM is a plated wire memory with a storage capacity of 8192 24-bit words.

4. Communications Subsystem

The communications subsystem consists of the UHF relay communications equipment (RCE) and the S-band direct communications system (DCS). The operation of these systems is illustrated in Figure I-10. The RCE consists of a three-power level solid-state transmitter and a low-gain turnstile over

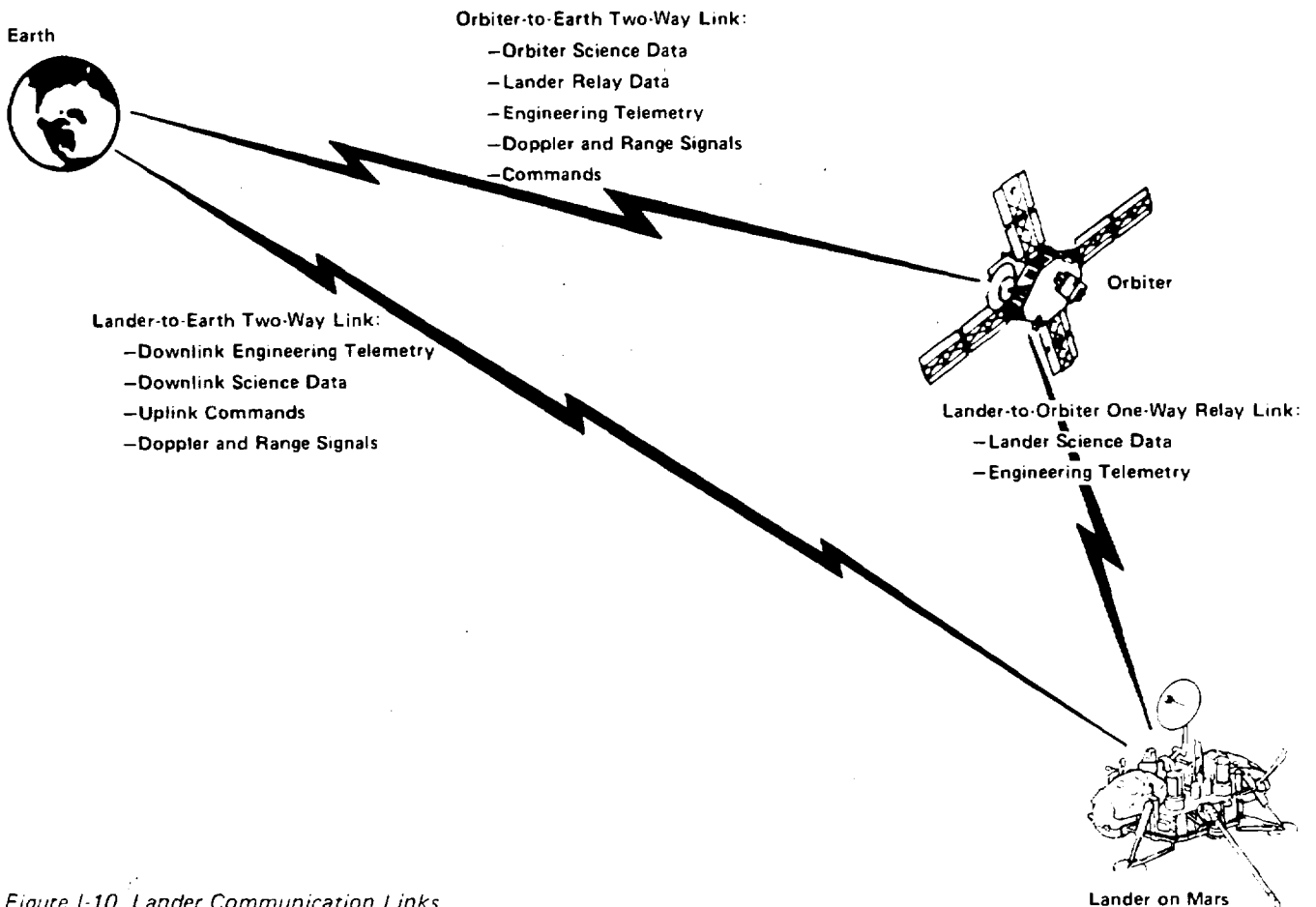

Figure I-10 Lander Communication Links

grid-reflector antenna. The relay link is used to downlink data to Earth via the Orbiter. UHF communications are used to transmit engineering and science data during deorbit, entry, terminal descent, and landed operations. The transmitter has three modes: 1, 10, and 30 watts. Transmission rates are 4 or 16 kbps. This system is not block redundant, but is redundant to the downlink function of the direct link.

The DCS consists of two command receivers, one using a low-gain antenna and the other using a steerable, parabolic dish high-gain antenna (HGA). The command receivers provide the uplink command subcarriers to two command detector/decoders. Each detector/decoder provides a parallel single-error corrected bit stream to the GCSC for updating Lander sequences. The receivers provide a coherent drive signal to two modulator/exciter, only one of which is powered. The operating modulator/exciter provides the radio frequency input drive signal to two traveling-wave-tube-amplifiers (TWTAs), only one of which is powered. The output signal from the operating TWTA is connected to the HGA via a radio frequency switch. In addition, the receiver that is connected to the HGA has the capability to detect a wideband coded signal which is retransmitted to Earth to provide slant range information.

To use the inherent redundancy of the DCS, it is cross strapped automatically and/or via Earth commands. Coherent drive selection for the modulator/exciter and command subcarrier input selection for the detectors/decoders are achieved automatically. The modulator/exciter and TWTA selection is accomplished by GCSC preprogrammed sequences which can be altered by Earth commands.

The data rates for the DCS are:

- 1) 8-1/3 bps for real-time engineering data;
- 2) 250, 500, or 1000 bps for science or non-real-time engineering data, coded to minimize transmission errors;
- 3) 4 bps for uplink commands.

Downlink transmission durations are constrained to below approximately 80 minutes per day by thermal and power limitations. Uplink command transmission durations are constrained to encompass the time required for receiver acquisition, command load, downlink, and specified command contingency.

5. Propulsion Subsystem

The propulsion subsystem consists of a reaction control deorbit system (RCS) that provides impulse for deorbit and attitude control through entry, and a terminal descent (TD) system that provides velocity and attitude control during terminal descent. The RCS consists of four engine modules located on the base cover and two fuel tanks located inside the base cover and mounted on the aeroshell. The TD system consists of three engines, four roll thrusters, and two fuel tanks, all located on the Lander body.

Each RCS engine module consists of three thrusters: a pitch/yaw pair, and a roll thruster. The thrusters are spontaneous catalytic monopropellant engines with specific impulse greater than 160 lb-sec/lbm. Redundancy is provided so that the mission can be performed without degradation if any one valve fails open or closed or a symmetrical pair of valves fails closed.

The RCS and the TD systems are both blow-down-pressure fed, hydrazine monopropellant propulsion systems. The fuel tanks are titanium spheres containing propellant and nitrogen pressurant.

There are three 600-lb-thrust spontaneous catalytic monopropellant terminal descent engines equally spaced around the Lander body. Thrust is controlled by metering hydrazine with a throttle valve. Eighteen nozzles per engine disperse the plume to reduce surface pressure, minimizing landing site alteration. The terminal descent roll engines are identical to the RCS thrusters and provide redundancy in the event a valve fails closed.

6. Pyrotechnic Subsystem

The pyrotechnic subsystem provides the pyrotechnic control circuitry, pyrotechnics, and pyromechanical devices required to perform various Lander functions. These components are fired on command from the Orbiter and GCSC. This subsystem contains the Lander pyrotechnic control assembly (LPCA), pyrotechnics (initiators, pressure cartridges, and parachute mortar cartridges), and pyromechanical devices (separation nuts, pin pullers, cutters, and valves).

The LPCA performs arm, fire, and safe functions for all pyrotechnics on the Lander. Capacitor

energy storage is used with firing circuits that are isolated from all other Lander power circuits. The LPCA accepts discrete commands from the Orbiter and digital commands from the GCSC. The energy required to fire the pyrotechnics is stored in capacitor banks in the LPCA. Energy storage is compatible with the Viking standard initiator—a 1 amp, 1 watt, no-fire initiator. Two LPCAs are used on each Lander. Each LPCA fires one bridgewire of each pyrotechnic device so that failure of one LPCA does not affect the mission. Both LPCAs are mounted external to the Lander body near leg 1.

7. Thermal Control Subsystem

The thermal control subsystem provides an acceptable temperature environment for all Lander components and structures. Thermal control is achieved for all mission phases by using a combination of passive and active elements.

Passive thermal control is accomplished through geometrical considerations and selection of materials that have the desired surface optical properties. In addition, optimization of equipment location and material selection are used to achieve the required thermal balance. Radioisotope thermoelectric generator (RTG) wind covers are used to isolate the RTGs from the wind, thus preventing excessive cooling. The covers also allow adequate heat loss by radiation to prevent overheating in the cruise vacuum environment. Surface coatings with the desired infrared emittance and solar absorptance optical properties are used to provide the required thermal radiation characteristics on all surfaces. Two types of thermal insulation are used to control heat flow between equipment and the environment: (1) multilayer radiation shield insulation for use in vacuum; and (2) bulk fibrous insulation for use in both vacuum and the Martian atmosphere.

Active thermal control techniques include electrical heaters and variable thermal resistance devices (thermal switches). The heaters are controlled by software and thermostats, many of which are redundant. Cycling of the RCS thrusters during de-orbit coast also provides a source of heat for temperature-sensitive valves. Thermal switches are used to maintain internal Lander body temperatures by directing waste heat from the RTGs to the equipment mounting plate as internal temperatures decrease.

8. Structures and Mechanism Subsystem

The more important elements of this subsystem are: bioshield; aerodecelerator (aeroshell/base cover/parachute); Lander body; landing legs; and high-gain antenna deployment mechanism.

Bioshield—The bioshield prevents recontamination of the sterilized Lander with Earth organisms by completely encapsulating it during and after sterilization. It is composed of three major sub-assemblies: equipment module, bioshield cap, and bioshield base. The equipment module, located in the center of the bioshield cap, separates with the cap by three ejector devices shortly after launch. The equipment module provides a bulkhead for interfacing electrical and instrumentation harnesses and propellant and pressurization lines before launch. Both the cap and base are fabric assemblies supported by aluminum tube. The base also provides the structural and electrical interface with the Orbiter.

Aerodecelerator—The aerodecelerator consists of the aeroshell, disc-gap-band parachute, parachute mortar, mortar support truss, and the base cover. The aeroshell is used during atmospheric entry and the parachute is deployed and used from approximately 19,000 ft to 4,600 ft.

The aeroshell is a blunted cone with an offset center of gravity that provides a lifting body configuration during entry. Entry heat is dissipated by an ablative coating on the exterior surface. This heat shield is a phenolic honeycomb, filled with ablative material, and attached to the aeroshell structure, which is aluminum ring frames, skin panels, and longerons. Three spring-loaded guide rails are used to achieve a positive and controlled separation from the Lander body. The rails pass through rollers on the Lander body.

The base cover protects the back of the entry capsule from the flow of hot gases off the aeroshell during entry. The base cover is constructed of an inner cone of laminated glass fabric and phenolic resin, which is transparent to UHF radio frequencies, and an outer cone of aluminum alloy. The base cover is integral with and supported by the mortar support structure. The base cover separates with the parachute and uses rails and rollers similar to the aeroshell.

The parachute is a 53-ft disc-gap-band type and is deployed through the base cover by a pyro-

technically energized mortar at an altitude of 19,000 ft. The parachute reduces the Lander velocity and reduces the flight path angle to 20 deg or less from the local vertical before the Lander descends to an altitude of 4,600 ft. The drag from the parachute also assists in aeroshell separation and carries the parachute/base cover combination away from the Lander after terminal engine ignition.

Lander Body—The Lander body provides proper thermal environment and structural integrity for all equipment required during terminal descent and landed operations. All power, communication, telemetry, guidance and control, and science components required to perform these operations are located on or in the Lander body. The body is an aluminum and titanium triangular shaped assembly with the landing legs located on each apex. The internal components, mounted on an equipment plate located at the top of the body, are thermally isolated from the rest of the body.

Landing Legs—The Lander has three landing legs that are designed to accomplish the following:

- 1) Provide a stable (upright) landing on the Martian surface;
- 2) Provide for energy absorption that minimizes landing shock;
- 3) Actuate the terminal engine shutdown switch at first leg contact;
- 4) Support the Lander during landed operations in a manner that satisfies the transmissibility requirements imposed by the seismometer and stiffness requirements imposed by the Lander cameras and high-gain antenna.

Each leg consists of a main strut assembly and an A-frame that includes the footpad. The legs are released by pyrotechnics and deployed by springs 7 sec after aeroshell separation and locked in an extended position. Load attenuators and bonded crushable aluminum honeycomb are used in the main struts for load attenuation and energy absorption during landing.

High Gain Antenna Deployment Mechanism—This mechanism provides structural support for the high-gain antenna (HGA) in the stowed position during the mission through landing. After landing it releases, erects, locks in place, and supports the HGA in its deployed position. On GCSC command after landing, a pyrotechnically-actuated pin puller is actuated and deployment is initiated through a

rotational spring. A governor regulates the deployment motion to limit acceleration and shock on the antenna. The antenna location and deployment mechanism is designed to provide an unobstructed line of sight to the Martian local horizon.

D. VIKING LANDER SCIENCE

The Viking Lander science instruments are listed in Table I-1. This table lists the science investigations required to satisfy the program goals with the specific Lander hardware used to perform these investigations.

Table I-1 Viking Lander Science Experiments

	Investigations	Instruments
Entry	Atmospheric Composition	Mass Spectrometer, Retarding Potential Analyzer, Pressure and Temperature
	Atmospheric Structure	Sensors, Accelerometers and Radar Altimeter
Landed	Imaging	Two Facsimile Cameras, Color/Stereo Capability
	Biology	Three Analyses for Photosynthesis, Metabolism and Growth; Samples Delivered by Surface Sampler
	Molecular Analysis (Organic and Atmospheric)	Gas Chromatograph Mass Spectrometer (GCMS); Samples Delivered by Surface Sampler
	Inorganic Chemical Analysis	X-Ray Fluorescence Spectrometer (XRFS); Samples Delivered by Surface Sampler
	Meteorology	Pressure, Temperature, Wind Velocity, and Wind Direction Sensors
	Seismology	Three-Axis Seismometer
	Magnetic Properties	Magnet Array on Surface Sampler, and Reference Test Charts, Cameras Used for Visual Study of Particles
Physical Properties		Analysis of Visual and Engineering Data from Applicable Instruments and Experiments:
		Cameras—Visual Study of Surface Characteristics (e.g., clumping, grain size, cohesion, adhesion, etc)
		Surface Sampler—(with Cameras) Trenches, Engineering Force Measurements, Porosity, Bearing Strength
Radio	Orbiter/Lander Location, Atmospheric and Planetary Data, Interplanetary Medium	Orbiter/Lander Radio and Radar Systems

1. Entry Science Investigations

As the Lander descends through the Martian atmosphere and performs the functions necessary for landing, instruments aboard the Lander and aeroshell take measurements of the physical and chemical properties of the ionosphere and atmosphere.

The upper atmospheric mass spectrometer (UAMS) is mounted on the aeroshell and measures the amounts and types of gases in the upper atmosphere. The data are gathered from approximately 23,000,000 ft to 330,000 ft altitude. The UAMS also helps define the biological environment by determining whether life-supporting atmospheric components are present.

The retarding potential analyzer (RPA) is mounted on the aeroshell and measures ion and electron densities and energies in the upper atmosphere. Using these data, ion and electron temperature profiles, and ion type and concentrations can be determined. The instrument can also detect the bow shock wave caused by the effects of the Martian atmosphere on the solar wind. The RPA is turned on shortly after deorbit burn, operates every few minutes during the initial part of the descent, and then continuously over the altitude range covered by the UAMS.

Aeroshell stagnation pressure and the recovery temperature instruments gather data during the aeroshell and parachute phases of the mission. Temperature and pressure sensors mounted on the Lander record the temperature and pressure of the atmosphere during terminal descent subsequent to aeroshell staging and also provide data after landing. The data from these instruments are combined with accelerometer data to reveal density, temperature, and pressure profiles of the Martian atmosphere.

2. Surface Investigations

Following touchdown, the Landers began scientific exploration of the surface of Mars. This begins with imaging sequences and continues with the use of all landed science instruments.

The Lander imagery system uses two cameras that provide the capability to view the entire circumference of the landing site from the Lander footpads to 40 deg above the horizontal. This per-

mits images of test targets on the Lander body, closeup shots of the Martian surface, and panoramas of the landing site. Images are available in high resolution, survey, color, stereo, and infrared. Photographs aid in understanding the composition and evolution of the Martian surface by studying its surface characteristics. The cameras also investigate the landing area for likely areas for soil sampling, for verification of sample acquisition, and for support of the physical and magnetic properties experiments.

The biology instrument conducts three experiments that search Martian surface samples for living microorganisms. The labeled-release experiment looks for signs of metabolism by measuring the amount of radioactive gas evolved from Martian sample material following injection of labeled nutrients. The pyrolytic release experiment looks for microorganisms by measuring the ability of the Martian sample material to incorporate labeled gases (CO and CO₂) into organic material. The gas-exchange experiment looks for microorganisms measuring changes in the gases in a closed environment following injection of a wet nutrient.

The gas chromatograph mass spectrometer (GCMS) performs organic chemical analyses of the Martian soil and analyzes the components of the Martian atmosphere at the surface. The surface sampler delivers samples from the Martian surface to the GCMS. These 100-milligram samples are heated to various temperatures to vaporize different organic compounds in the sample. The vapors are swept off to the gas chromatograph and mass spectrometer by hydrogen carrier gas. This investigation can reveal chemicals indicative of past or present life on the planet, but cannot detect life per se.

The X-ray fluorescence spectrometer (XRFS) is used to perform inorganic chemical investigations. The XRFS analyzes samples from the Martian surface (delivered by the surface sampler) for chemical elements. The instrument can detect most elements known to exist in the solar system.

The meteorology instrument is a package of sensors located on a boom near leg 2, which is deployed and locked in place shortly after landing. These instruments measure atmospheric temperature, wind speed, and wind direction. These Lander data along with Lander pressure measurements are correlated with Orbiter data to understand Martian atmosphere and weather.

The seismology investigation uses a three-axis seismometer. This instrument analyzes data on volcanic activity, planet structural shift, and meteorite impact on Mars surface. These data can reveal the mechanical structure of Mars.

The surface sampler contains a 10-ft furlable tube boom capable of acquiring surface samples in

an approximate 130-sq-ft area generally in front of and between legs 2 and 3. Surface samples are provided to the biology instrument, the GCMS, and the XRFS. The surface sampler also supports the physical/magnetic properties investigations through physical operations and use of mirrors and magnets on the boom itself.

ORIGINAL PAGE IS
OF POOR QUALITY

II. MISSION DESCRIPTION

- A. Launch and Interplanetary Cruise
- B. Mars Orbit Insertion to Separation
- C. Separation Through Landing
- D. Landed Operations

This photograph, taken from Lander 1 on July 23, 1976, shows the United States flag, Bicentennial symbol, and student emblem on the RTG cover. The view is toward the west and the large hill in the center may be part of a crater rim.

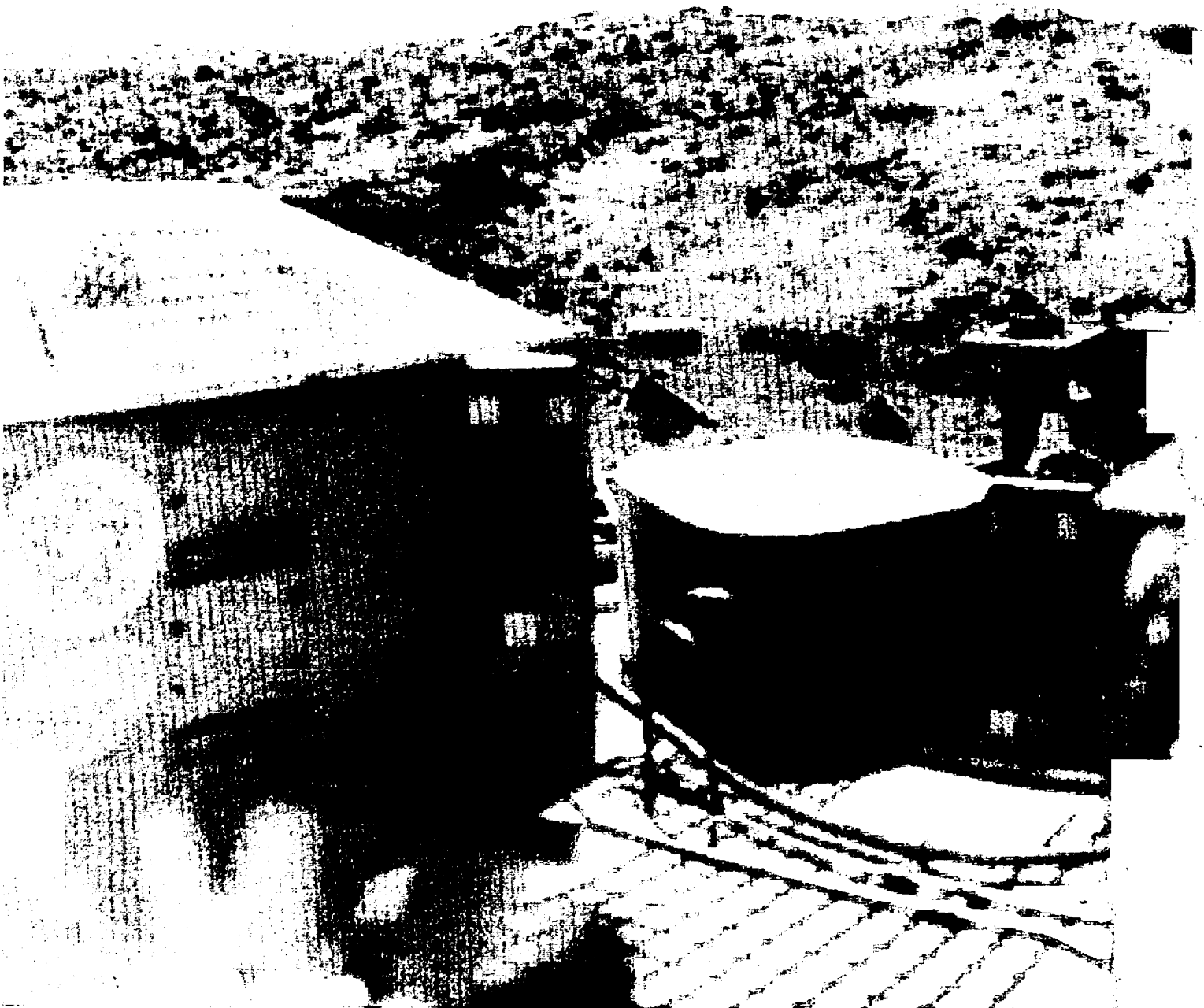

II. MISSION DESCRIPTION

This chapter describes the Lander performance at the system level throughout the primary mission and identifies the significant Lander anomalies and corrective action in the phase where they occurred. A more detailed description that includes subsystem performance may be found in Chapters III through VI. Because this is an engineering performance report, considerable text is devoted to the description of anomalies. These anomalies did not detract from the proven reliability of the Landers and overall success of the Viking mission. The Landers were designed to contain redundancies and other features to overcome such problems and it is evident that sufficient margin was available.

A. LAUNCH AND INTERPLANETARY CRUISE

Immediately following nominal launches, a number of spacecraft events occurred that prepared the spacecraft for the cruise activity. The major Lander event was separation of the bioshield cap which was successfully implemented by Orbiter command approximately 2 hr after launch. The Landers relayed engineering data through their respective Orbiters and all parameters were nominal except for a decrease in RTG 1 pressure on Lander 1. This was determined to have been caused by a leak in the pressure transducer reference cavity and all RTG operation continued as predicted.

The day after both launches, ground commands were issued to power up GCSC A and B on both Landers and to perform memory readouts. Analysis of these data indicated perfect system operation and no memory discrepancies.

During the cruise phase, there was a requirement to periodically exercise the Lander tape recorders. This activity began 15 days after each launch and was performed approximately every 30 days thereafter. During this maintenance activity, Lander format 5 data were eventually recorded on all four tracks on each Lander. These data were then partially played back during the maintenance activity. Analysis showed no anomalies.

Thermally, the Landers' temperatures stabilized at approximately 70°F inside the Lander body after about 8 days. All Lander temperatures were similar to flight article test data obtained in previous thermal vacuum tests.

The major operation on both Landers during cruise was to perform a cruise checkout that provided more detailed information on Lander subsystem health. Specifically, the cruise checkouts accomplished the following objectives:

- 1) Provided detailed postlaunch Lander subsystem status;
- 2) Validated in-flight IRU calibration and verified ability to process data through ground software;
- 3) Established a good set of baseline data that could be used for reviewing preseparation checkout data;
- 4) Trained flight personnel for preseparation operations.

In preparation for cruise checkout, the batteries on both Landers were charged to support the checkout loads. The batteries on Lander 1 were charged and all operations were nominal. Each of the four batteries was separately charged for about 24 hr. Temperature increases were well under predictions and battery charging was terminated by the PCDA after the proper voltage/temperature combination was achieved. On Lander 2, attempts to charge the batteries with BPA charger A were unsuccessful. Analysis and further testing concluded that the failure was in a bias circuit in the BPA charger A that controls the output current. Transfer was made to BPA charger B and all four Lander 2 batteries were successfully charged without further anomalies. However, a decision was made to maintain at least one charged battery on each Lander through the cruise phase. Battery B remained charged and no further battery charger anomalies were observed.

Both cruise checkouts were conducted as scheduled (Lander 1 on November 12, 1975 and Lander 2 on November 21, 1975) and results were excellent. All hardware operations were nominal. IRU calibration ground software worked much better than could normally have been expected for first usage. Also, complete data were acquired from both Landers for comparison during preseparation checkout. The cruise checkouts were so nominal and successful that the second checkouts scheduled for January 1976 were cancelled.

Subsequent to the cruise checkouts, a number of GCMS operations were conducted on each

Lander. These operations: (1) vented portions of the GCMS to space, thereby reducing the level of the trapped terrestrial gases; (2) performed bake-outs to reduce instrument contaminants; and (3) characterized sample ovens to be used for analyses of first surface samples. After analysis of these data and prelaunch data, it was concluded that oven 3 on Lander 1 and oven 1 on Lander 2 were not operable. Therefore the landed mission was designed so that organic analyses using the remaining two good ovens were scheduled for the GCMS on each Lander. The tests on Lander 2 also indicated that the soil carriage position indicator had failed. This function is not critical in that operations can be designed based on past knowledge of carriage location. This did not affect landed GCMS operations. No further anomalies were observed.

After GCMS operations, the Lander batteries were not required for further operations until pre-separation. Therefore, three batteries on each Lander were discharged. Battery B on each Lander was left on low rate charge to assure transfer to internal Lander power in case of further BPA

charger anomalies. To condition the batteries for use in separation through the remainder of the mission, the batteries were subjected to a series of charge/discharge cycles in May through June 1976. This conditioning ensured that all batteries would accept a full charge. These activities occurred as scheduled and all operations were completely nominal. At the completion of this activity, the batteries were left on float charge (in a charged state) in preparation for separation activities. During this same period, both sides of both computers were loaded with the software required to perform a preprogrammed mission in the event no uplinks were acquired after touchdown. These initial computer loads required several hours of operation on each Lander and were successfully performed with no memory "miscompares."

Tape recorder maintenance also continued during the first half of 1976. Lander meteorology tests were conducted in conjunction with the tape recorder maintenance. This provided data to the meteorology science team for determining instrument biases. All operations were nominal.

B. MARS ORBIT INSERTION TO SEPARATION

In preparation for Mars orbit insertion (MOI), final course corrections were planned for the spacecraft. This maneuver was planned for Viking 1 on June 9, 1976—ten days before MOI. Just prior to the maneuver, a small leak was discovered in the Orbiter propulsion system's pressurization supply. Operational alternatives were planned and implemented that resulted in two Orbiter approach burns that permitted MOI to occur essentially as planned on June 19. These activities were completely successful and did not compromise the Viking 1 mission. However, in studying various alternatives an analysis was performed to determine if the Lander could be separated from the Orbiter and perform a direct entry instead of an entry and descent from Mars orbit. This study determined that a Lander direct entry was possible and the probability was good that a successful landing could be achieved. Nevertheless, Viking performed its approach maneuvers in an uneventful manner and MOI was successfully achieved on June 19, 1976, for Viking 1 and August 7, 1976, for Viking 2.

Once in Mars orbit, Viking 1 began its search for a safe and a scientifically interesting landing site. The preselected site was determined to be unsafe, thus delaying the planned landing date of July 4. A new site was eventually selected based on Orbiter and Earth-based radar data and a landing was planned for July 20. In preparation for this, the Lander batteries were removed from float charge on 12 July to allow the Lander to cool in preparation for preseparation checkout. A final descent trajectory was chosen and the programmed mission in the selected GCSC side (side A) was updated at approximately separation minus 39 hr

(S - 39 hr). This same update was transmitted to the Lander Support Office in Denver, Colorado, and independently verified by computer simulation. The Orbiter activated the Lander at S - 30 hr and the Lander performed a preseparation checkout for approximately 5 hr. This checkout provided a detailed status of the Lander subsystems. All hardware operation was completely nominal. It was determined that an update could be made to the GCSC software to improve the landed XRFS instrument data and this change was sent (uplinked) to the Lander at S - 9.5 hr.

After preseparation checkout, all four Lander batteries were recharged to a full state in preparation for separation. At S - 3.5 hr, the final separation sequence began. During this final period the Lander IRU was warmed up and a final review of Lander status was performed. All Lander elements were "go." At S - 1 hr the flight team at JPL transmitted the "go" command that allowed the Lander to continue to separation. All events occurred exactly as planned and Lander 1 separated from Orbiter 1 at 1:51 a.m. PDT, July 20, 1976.

The operations concerning Lander 2 were equally successful. After MOI, the landing site selection for Lander 2 continued. A site was eventually selected that promised more water, was at a more northern latitude, and almost 180 deg around the planet from Lander 1. During preseparation checkout, one of the four TDLR beams (channel 2) indicated anomalous tracker acquisitions. A decision was made to exercise a preplanned GCSC software option to ignore the channel 2 data during descent. This option was enabled at the S - 9.5 hr uplink opportunity. No further anomalies were observed and separation occurred exactly on schedule at 12:40 p.m. PDT on September 3, 1976.

C. SEPARATION THROUGH LANDING

The major Lander events from separation through landing are shown in Table II-1. A comparison of when these events actually occurred versus planned times is also provided.

Figures II-1 and II-2 provide a graphic illustration of the events during this mission phase.

Separation from the Orbiters was pyrotechnically initiated and springs imparted a small relative velocity. The separation of both Landers was very nominal. The Lander UHF relay link was initialized (turned on) just before separation and Lander engineering and science data acquired during separation through initial landed operations was relayed by the Orbiter to Earth in real time. This allowed near-real-time observation of the Lander performance. This relay operation worked perfectly for Lander 1. Shortly after Lander 2 separated, Lander telemetry suddenly ceased. The problem was eventually isolated to an Orbiter IRU power failure that had caused the Orbiter to point its high-gain antenna away from Earth. The problem was completely corrected but not until several hours after Lander 2 had successfully landed. Therefore,

Lander engineering and science data were not received on Earth for several hours after landing. The Orbiter 2 low-gain link was reinitialized about 1 hr after separation and this permitted analysis of real-time received signal strength of the Orbiter relay radio indicating the Lander had gone through the necessary events and had achieved a successful landing.

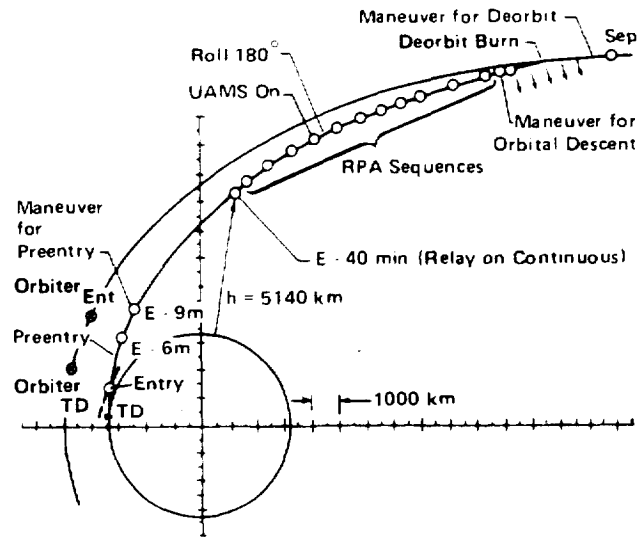

Figure II-1 Lander Separation-to-Entry Sequence

Table II-1 Major Lander Separation through Landing Events

Lander Event	Lander 1 Time		Lander 2 Time	
	Actual	Planned	Actual	Planned
Separation	S - 0		S - 0	
Start De-orbit Burn Orientation, sec	S + 241	S + 241	S + 241	S + 241
Start De-orbit Burn, sec	S + 421	S + 421	S + 421	S + 421
End De-orbit Burn, sec	S + 1,759.8	S + 1,757	S + 1,757.1	S + 1,757
Start Entry Orientation, sec	S + 10,973	S + 10,973	S + 10,997	S + 10,997
Start Atmospheric Entry, sec	S + 11,513	S + 11,513	S + 11,357	S + 11,357
Deploy Parachute (Mortar Fire), sec	S + 11,942	S + 11,932	S + 11,791	S + 11,767
Ignite Terminal Engines, sec	S + 12,004	S + 11,992	S + 11,855	S + 11,826
Landing, sec	S + 12,050	S + 12,035	S + 11,901	S + 11,869

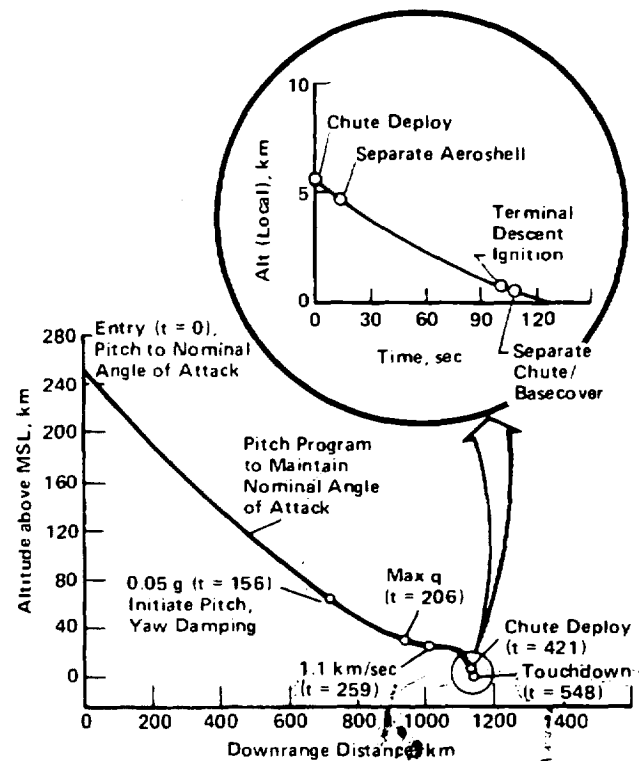

Figure II-2 Lander Entry Sequence

During the 4 minutes following separation, the Lander accelerometers were calibrated. The attitude control system was activated and the Lander oriented for deorbit burn. The deorbit burns started at S + 7 min and lasted on both Landers for approximately 22.5 min. Attitude rates were above those predicted, but resulted in no adverse effects. All other operation was nominal.

After deorbit burn, the Landers were reoriented for RPA operation and deorbit coast began. During this period, RPA and engineering data were relayed to the Orbiter for about 70 sec every 6.5 min. The deorbit coast phase continued for approximately 2.5 hr on each Lander. All operations were nominal except for the attitude rates that exceeded those predicted; however these higher rates caused no problems.

Approximately 3 hr after separation, the Landers were oriented for entry, and entry subsystems activated. The remainder of the entry science instruments also began their operation. During atmospheric entry, both Landers experienced higher lift-to-drag ratios than predicted, but this was beneficial in reducing entry velocity. No communications blackout occurred on either Lander during entry.

Following entry, the parachute was deployed at 19,273 ft for Lander 1 and 19,244 ft for Lander 2 and inflation occurred less than 2 sec later. Seven seconds later the aeroshells were pyrotechnically separated. The landing legs were deployed and locked in place and a roll maneuver accomplished to align the Lander with the azimuth desired after landing to assure proper lighting of the surface sample area for subsequent imaging activity.

At 4787 ft for Lander 1 and 4718 ft for Lander 2 (4798 ± 300 desired), the terminal engines were ignited. Two seconds later, the parachute and base cover were separated. The Landers then began terminal descent maneuvers that changed the flight path to a vertical descent. Constant velocity descent began at 63 ft for both Landers (55 ft planned). The landing legs then sensed touchdown and a pyrotechnically operated valve shut down the engines. During the last 0.5 sec of descent, both Landers exhibited a momentary increase in throttle setting for one or more of the terminal descent engines. This has been attributed to the sensing by the TDLR of dust blown up from the surface in the last few feet of the descent but, again, this caused no problems. The axial velocity of the Landers was 8.1 and 8.2 ft/sec with a design capability of 8.0 ± 3.0 ft/sec. The final landing positions are summarized in Figures II-3 and II-4.

Lander 1 touched down successfully at 5:12 a.m. PDT on July 20, 1976, and Lander 2 at 3:38 p.m. on September 3, 1976. As can be seen from the preceding data, all operations were incredibly nominal and exceeded all performance expectations.

Immediately following landing, the HGA, meteorology boom, and biology processing and distribution assembly cover were pyrotechnically deployed. Camera 2 on both Landers first imaged foot pad 3 and then provided a wide angle panorama of the landing site. These pictures and Lander engineering data were relayed to the Orbiters as they passed overhead and then relayed to Earth. These data showed perfect Lander operations and the pictures were very clear (Figures II-5 through II-8).

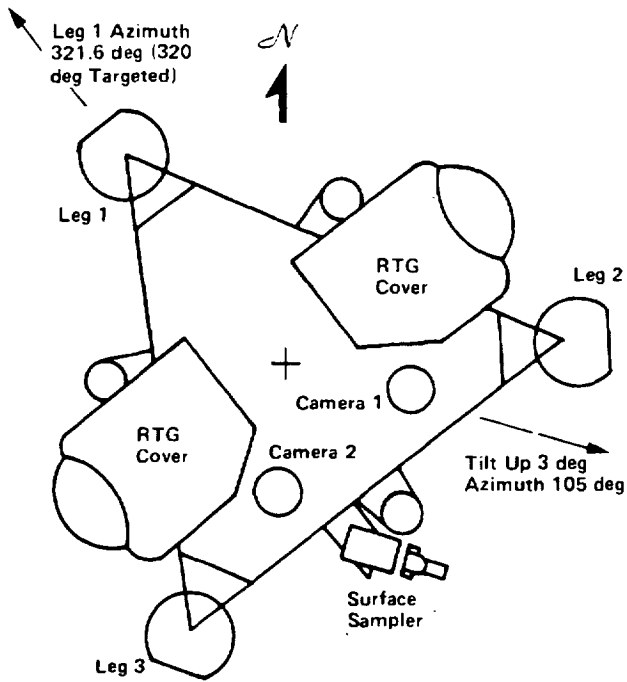

Lander 1 Location:
 Elevation below Mean Surface Level, -4600 ft
 Latitude, 22.46 deg N (22.4 Targeted)
 Longitude, 48.01 deg W (47.5 Targeted)

Figure II-3 Lander 1 Position on Mars

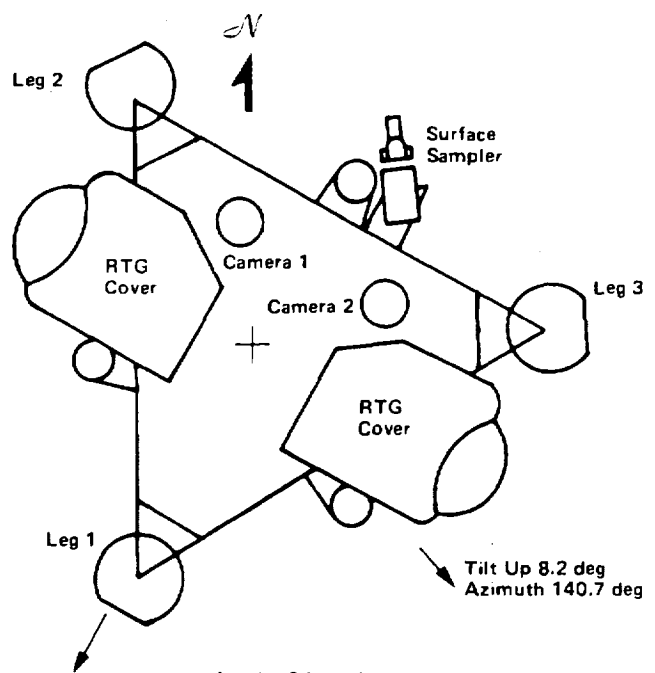

Lander 2 Location:
 Elevation below Mean Surface Level, -8860 ft
 Latitude, 47.96 deg N (47.9 Targeted)
 Longitude, 225.77 deg W (225.8 Targeted)

Figure II-4 Lander 2 Position on Mars

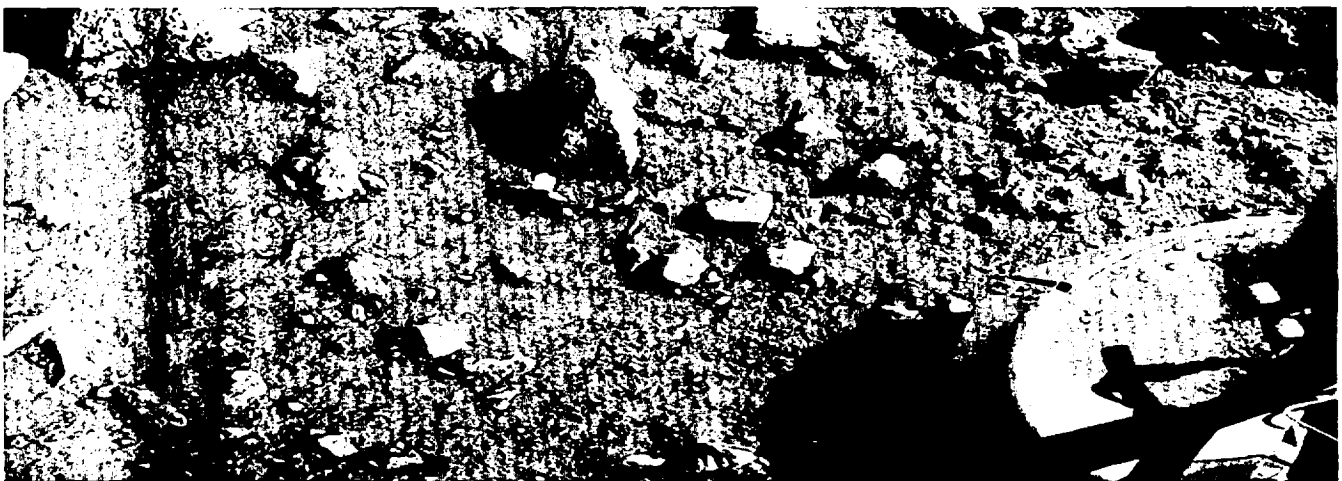

Figure II-5 First Image Taken on Surface of Mars, Lander 1, Footpad 3



Figure II-6 First Panorama from Lander 1

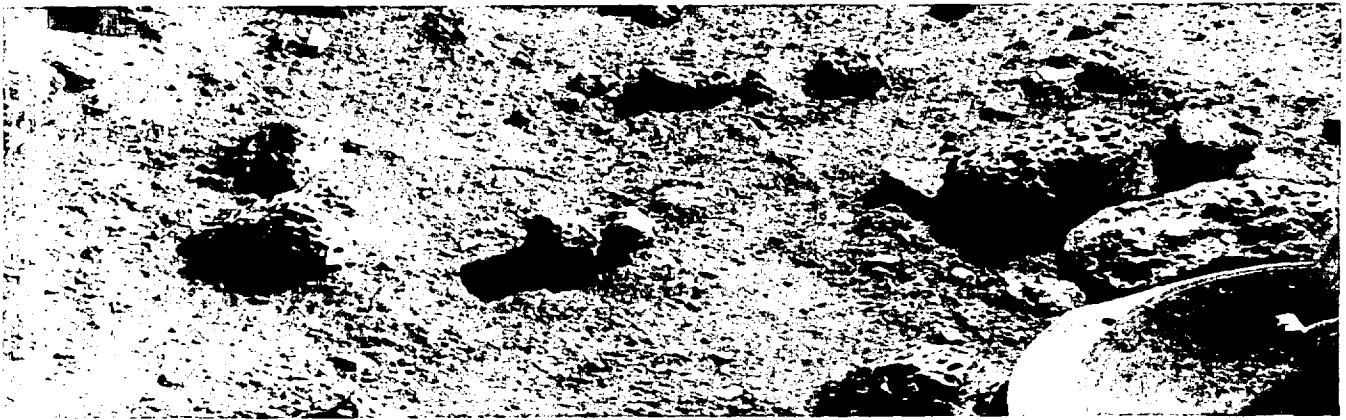

Figure II-7 First Image from Lander 2 Showing Footpad 3

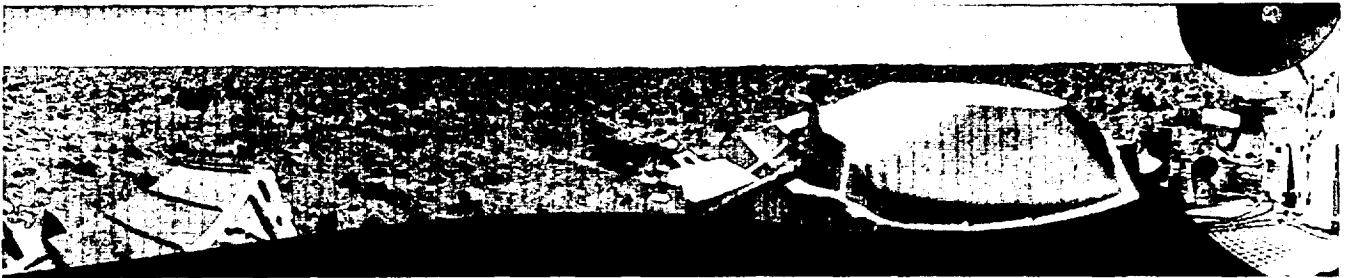

Figure II-8 First Panorama from Lander 2

D. LANDED OPERATIONS

After completion of the initial landed relay link, Lander 1 began its primary landed mission. This consisted of operating the various science experiments to achieve the landed science investigations of biology, molecular analysis, atmospheric analysis, imaging, inorganic chemical analysis, meteorology, seismology, physical and magnetic properties, and radio science. Many of these investigations were coordinated with and conducted in conjunction with complementary Orbiter science investigations. As Lander surface operations and Mars' surface characteristics were better understood, the landed mission contained in the GCSC software was updated through uplinks approximately every other sol. (A sol is one Martian day and is equivalent to approximately 24.6 hr.) Typically, the Lander engineering and science data were returned to Earth by a relay and direct link each sol. The Lander 1 primary landed mission was accomplished in the first 43 sols of operation. Lander 2 was then commanded to a reduced operational level during the Lander 2 separation, entry, descent, and primary landed mission. Lander 2 then conducted a very similar primary landed mission

for 61 sols. Both Landers were reduced to limited operations during the communications blackout that occurred during solar conjunction. Limited science and engineering data were stored on the Landers' tape recorders during conjunction and then transmitted back to Earth following conjunction.

Lander 1 performance during the primary mission was excellent, but not without some anomalies. The seismometer refused to uncage its sensing coils upon command. Additional attempts were made at uncaging but the instrument is still inoperable. Lander 1 S-band receiver 1, which is used as a backup for the primary high-gain receiver 2, failed to lock up (establish communication with Earth) after the first sol. Later in the mission it was locked up occasionally and appeared to be temperature sensitive. The exact cause of the problem has not been determined but the high-gain system has performed perfectly and the low-gain backup has not been required. Another relay link communication problem occurred on sol 2. The relay link transmitter selected a 1-watt transmission mode instead of the planned 30-watt mode. However, the relay link performance was excellent and

no data were lost. On sols 2 and 3 the relay links were in the 1-watt mode. Beginning with sol 4, the correct 30-watt mode was selected by Lander 1. This was assumed to be an electrical noise problem. Commands were uplinked to reduce such noise susceptibility during the relay link. The problem did not recur.

The surface sampler on Lander 1 provided the flight team with a number of challenges, all of which were overcome. On sol 2 a boom "no-go" occurred because the boom was not commanded to extend far enough and a locking pin did not drop free. On sol 5, new commands were issued, the boom extended far enough, and the pin fell free. Samples were then delivered on sol 8 to the biology, gas chromatograph mass spectrometer (GCMS), and X-ray fluorescence spectrometer (XRFS) instruments. After the soil delivery, the GCMS did not indicate it had received a full sample. The GCMS soil analysis was automatically delayed by the GCSC. It was decided to have the boom acquire a new sample and deliver this to the GCMS. After collecting the sample, another boom "no-go" occurred prior to GCMS delivery. By this time it was believed that the GCMS had received some soil in the first delivery and the GCMS soil analysis was started without waiting for another sample. Results indicated there was soil in the GCMS and the sample analysis was successful. Further analysis and tests determined the last boom "no-go" was caused by commanding two successive retract sequences. The boom was then subsequently exercised in extension and continued operations without further problems. The timely resolution of

these surface sampler anomalies pointed out early in the mission the flexibility and adaptability of the Lander design.

As a result of the above problems, some changes were made to the Lander 2 mission prior to landing and the operational problems of Lander 1 were not encountered. Lander 2 also experienced fewer hardware anomalies. The seismometer uncaged and operated perfectly. S-band receiver 1 locked up during all direct links. The surface sampler continued to be a challenge for the flight team. On sol 8 of Lander 2 operation, a boom "no-go" occurred after sample delivery to the biology experiment and before delivery to the XRFS. Analysis and further tests concluded that a switch sensing collector head rotation had malfunctioned. Further boom sequences were modified to preclude the need for this signal. No further surface sampler anomalies occurred and all deliveries were accomplished as scheduled. On sol 39 of Lander 2, the direct downlink was not received. After considerable analysis, it was determined that the most probable cause was a failure of traveling wave tube amplifier (TWTA) 1. TWTA 2 was commanded on and no further downlink problems occurred.

As conjunction approached, both Landers were commanded to reduced operating modes to await the end of the communications blackout caused by the sun passing between Earth and Mars. Both Landers entered this mission phase in excellent health.

III. LAUNCH AND INTERPLANETARY CRUISE PHASE

- A. Lander Subsystems' Cruise Mode Performance
- B. Battery Charging and Conditioning
- C. Cruise Checkout
- D. GCMS Vent, Bakeout, and Oven Characterization

ORIGINAL PAGE IS
OF POOR QUALITY

This dramatic photograph was returned from Lander 1 on August 20, 1976. The image scan was started just after the sun had set on the Martian horizon.

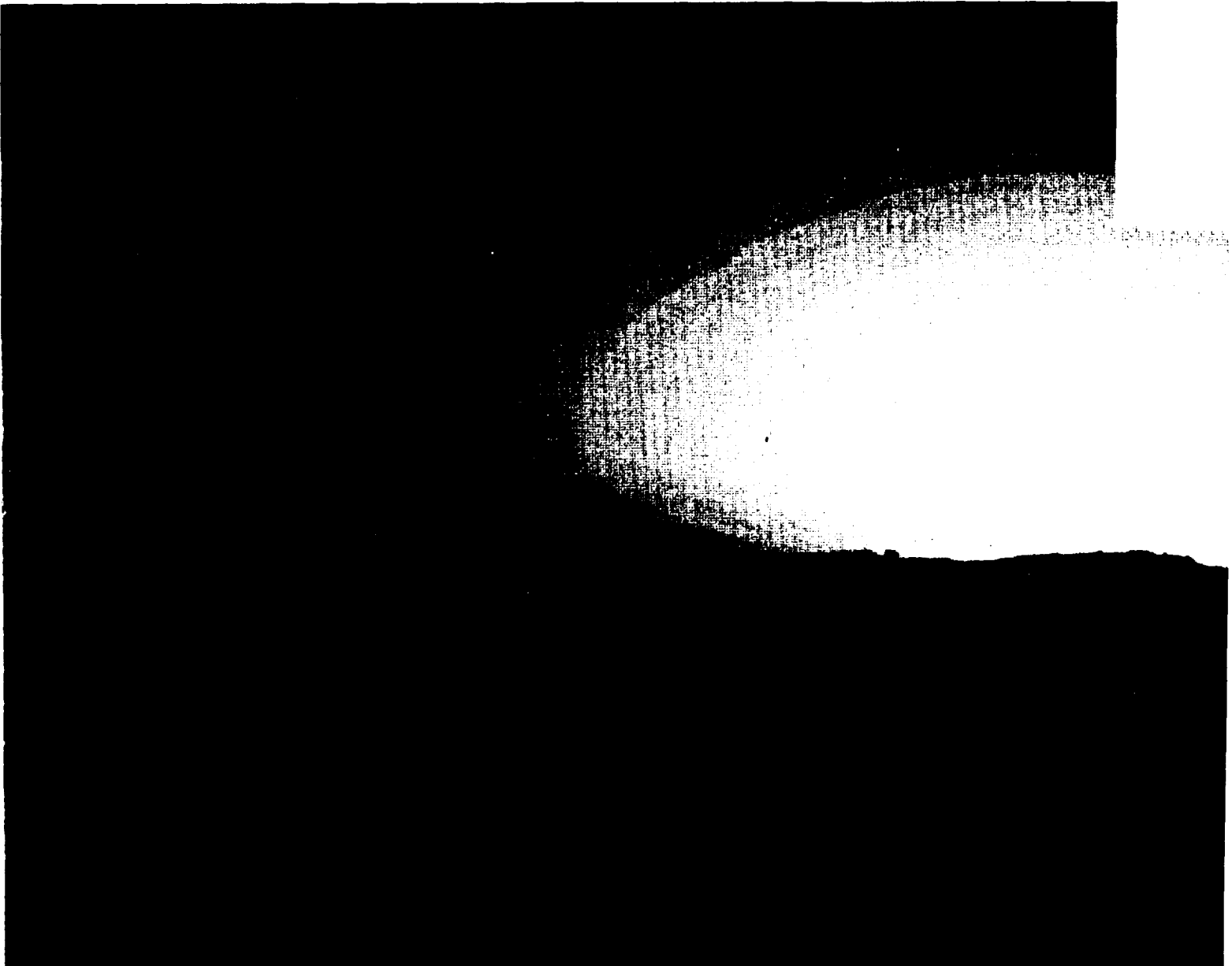

III. LAUNCH AND INTERPLANETARY CRUISE PHASE

The following sections provide more detailed Lander subsystem performance during the major mission phases. During most of the 10- to 11-month cruise phase to Mars, the Landers were in an inactive state with every limited subsystem operation. This limited-operation cruise mode is described in Section A. The shorter periods of high level Lander activity during the cruise phase that included battery operations, cruise checkouts, meteorology checkouts, and GCMS activities are depicted in Figure III-1 and detailed in Sections B, C, and D of this chapter.

A. LANDER SUBSYSTEMS' CRUISE MODE PERFORMANCE

1. Guidance and Control Subsystem

The entire guidance and control subsystem was inactive for the majority of the cruise phase. During Lander activities requiring internal control, the appropriate guidance control and sequencing computer (GCSC) was activated and used to control all Lander activities. The GCSC performed a self test each time it was turned on and a portion of its memory was relayed to the ground for analysis. All self tests occurred without an anomaly of any type. The memory readouts were compared to planned content and no "miscompares" were found. The GCSC memories were updated numerous times to enable specific cruise operations and to provide an updated program for separation through landed operations. These updated software programs for the landed missions were referred to as initial computer loads. All memory updates were performed without anomalies.

2. Power Subsystem

Power for the Lander cruise mode was supplied by the Orbiter to the bioshield power assembly (BPA). The BPA regulated and distributed this power to the few Lander components active in cruise, primarily telemetry and thermal heaters. The batteries were maintained in a discharge state except when required for cruise checkout, GCMS operations, and conditioning just before Mars orbit insertion (MOI). All power subsystem cruise mode operations were nominal and are summarized in the following paragraphs.

The RTGs were shorted to minimize degradation. Fin root temperatures stabilized at 350 to 360°F and hot junction temperatures were between 900 and 930°F, slowly increasing 10 to 15°F during the long cruise. RTG pressures were nominal at 15 to 19 psia. The batteries were discharged before launch to about 1.2 volts per cell. Voltage decreased during the first days of cruise as a result of telemetry load resistor energy drain. Table III-1 tabulates the Lander 1 battery discharges after launch.

Table III-1 Lander 1 Battery Discharge Voltage Following Launch

Days from Launch	Battery A	Battery B	Battery C	Battery D
0	29.8	29.8	29.8	29.8
10	29.5	29.5	29.2	29.2
20	27.0	24.8	22.3	19.5
30	15.4	13.1	12.6	10.7
40	11.0	10.7	7.2	6.9
50	6.3	5.4	4.7	4.7

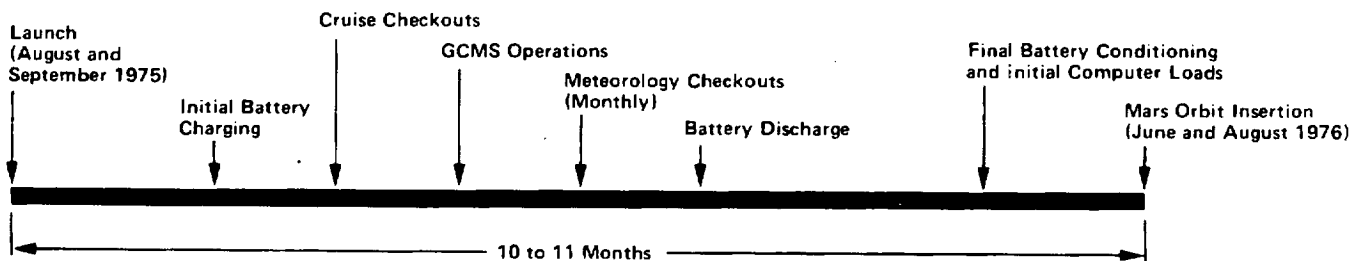

Figure III-1 Lander Interplanetary Cruise Phase Activities

Lander 2 batteries performed in a very similar manner except batteries C and D were initially 10 to 15 volts lower than A and B because of recharging for additional prelaunch checkouts.

Orbiter power was supplied to the BPA at about 44 volts. The BPA regulated this to 33 volts $\pm 5\%$ with a power limitation of 150 watts. This power was used for all cruise mode activities. The BPA converters worked perfectly for the 10- to 11-month cruise.

Lander loads powered by the BPA during cruise included the propulsion system thermal heaters and data acquisition and processing unit (DAPU). Input power varied from 34 to 71 watts as six propulsion heaters cycled continuously. The feedline heaters cycled at 30- to 100-minute intervals and the tank heaters cycled over a 2- to 3-day period. During the periodic tape recorder maintenance, the BPA also supplied power to the GCSC, power conditioning and distribution assembly (PCDA), and tape recorder. The tape recorder maintenance activities required bus peak power inputs of 109 watts.

3. Telemetry Subsystem

The DAPU was the most active Lander component during the cruise mode. DAPU side A was on continuously on both Landers for the entire cruise phase. It constantly monitored 65 channels of various engineering data, formatted these data, and relayed the data to the Orbiter for inclusion in other Orbiter data and transmission to Earth. These cruise mode data were referred to as format 1 data. The data storage memory (DSM) was not used. The tape recorder was periodically activated and format 5 (landed science and engineering data) eventually recorded on all four tracks and partially played back. This operation of the tape recorder prevented stiction of the tape to the head, insured even distribution of the bearing lubricants, and would have allowed lead time to plan workarounds if malfunctions had occurred. All telemetry subsystem functions were nominal.

4. Communications Subsystem

The communications subsystem was not active during the cruise mode. However, the command detectors were turned on and used for all GCSC updates and no anomalies were observed.

5. Propulsion Subsystem

The propulsion subsystem remained inactive during the cruise mode. Format 1 provided data on the status of the pressurized propellant tanks. All tanks remained stable with the deorbit tanks at approximately 76°F and 352 psi and the terminal descent tanks at 80°F and 532 psi.

6. Pyrotechnics Subsystem

The pyrotechnics subsystem was not active during the cruise mode.

7. Thermal Control Subsystem

During cruise, Lander thermal control was achieved primarily by passive means. Except during the brief Orbiter maneuvers, the Orbiter shaded the Lander and most of the RTG thermal energy radiated to deep space via the base cover. Thermostatically controlled heaters were located on the IRU, deorbit engine feedlines, and terminal and deorbit propellant tanks. These heaters were supplied power from the Orbiter. Component temperatures were maintained within flight acceptance test limits at all times. Actual cruise data correlated well with prelaunch test data and provided verification of the software thermal model (LTEMP) used for mission thermal predictions. The Lander steady-state temperatures at various times during cruise are shown in Table III-2.

During launch, the thermal transient was as expected. Internal temperatures increased for the first few hours because of increased equipment activity and the absence of the RTG water coolant used during prelaunch. Once in the deep space vacuum environment, temperatures cooled to predicted levels. About 8 days after launch, the average Lander equipment plate temperatures stabilized at 71°F for Lander 1 and 73°F for Lander 2. The launch transient temperature profiles are shown in Figures III-2 and III-3.

During the cruise phase, Lander temperatures were as predicted with Lander 2 internal temperatures remaining about 2°F warmer than Lander 1, which was consistent with prelaunch data. Thermally the Lander was designed to be almost independent of solar flux during cruise, and only about 4°F decrease was observed on the equipment plates. The IRU cover heater was on continuously except during the first Orbiter midcourse maneuver

Table III-2 Cruise Coast Temperatures (°F)

Item	September 1975		January 1976		June 1976*		Separation-40 hr	
	Lander 1	Lander 2	Lander 1	Lander 2	Lander 1	Lander 2	Lander 1	Lander 2
Average Equipment Plate	71	73	67	69	76	78	66	69
DAPU	80	83	77	81	85	89	77	80
Tape Recorder	71	74	68	71	73	76	66	69
Batteries	69	72	66	69	80	83	65	68
IRU	30	32	27	28	26	27	24	27
Deorbit Engines 1 & 4	-28	-27	-32	-31	-32	-31	-32	-31
Deorbit Engines 2 & 3	-49	-48	-51	-50	-51	-50	-51	-50
Terminal Tanks	75 to 83	73 to 82	75 to 83	73 to 82	75 to 83	73 to 82	75 to 83	73 to 82
Deorbit Tanks	72 to 80	72 to 80	72 to 80	72 to 80	72 to 80	72 to 80	72 to 80	72 to 80
RTG 1† Fin Root	363	358	363	358	363	356	363	356
RTG 2‡ Fin Root	359	353	359	353	357	353	357	353

*Batteries on float charge.
 †Telemetry data—average fin root temperature 14°F less.
 ‡Telemetry data—average fin root temperature 9°F less.

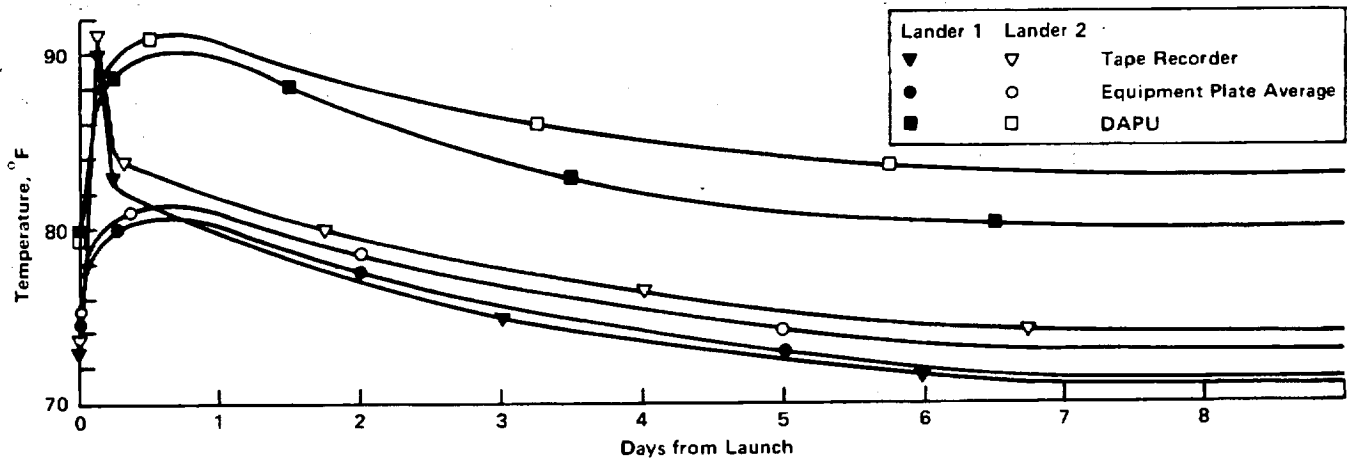

Figure III-2 Lander Launch Transient Internal Temperatures

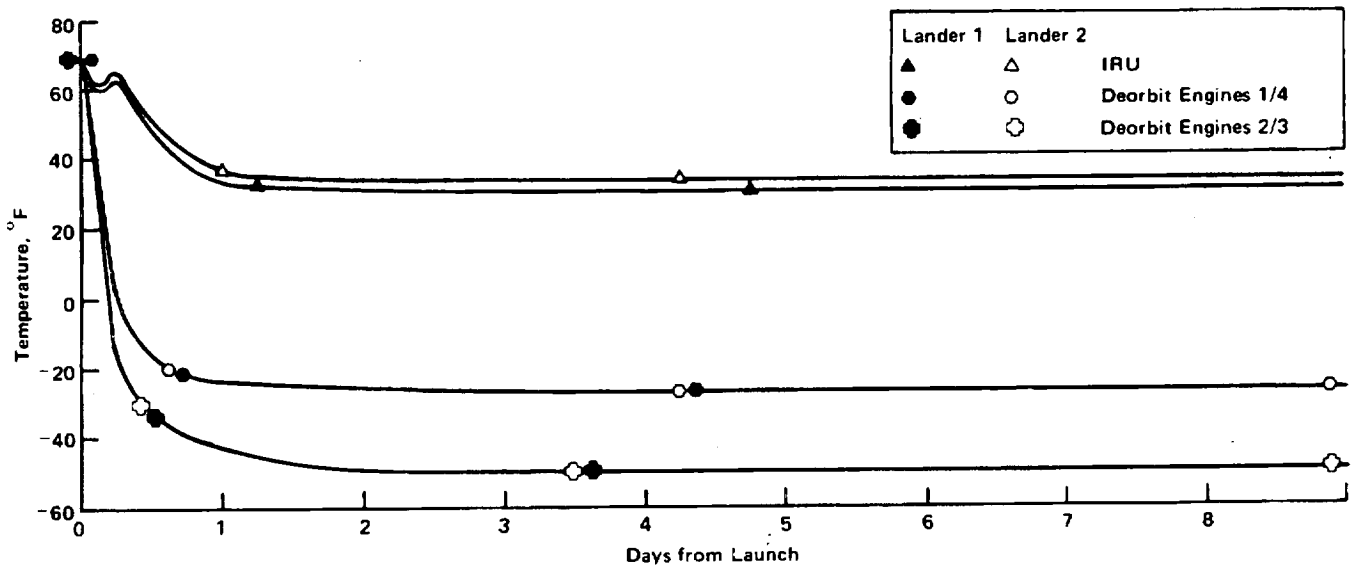

Figure III-3 Lander Launch Transient External Temperatures

and the Orbiter controlled tape recorder maintenance periods. The propulsion tank heaters worked normally. There was no temperature measurement on the thermostatically controlled deorbit propulsion feedlines, so nominal operation had to be derived from the Orbiter supplied current. These heaters worked as designed on both Landers; however, on Lander 1 one thermostat was believed to have failed in the closed position. This caused no problems since a series-redundant thermostat was provided and overall operation remained nominal.

The Orbiter performed several short-duration maneuvers (less than 2 hr off of sun reference) during cruise. Because of the large Lander thermal time constant, these maneuvers did not have any significant thermal effect.

Near the end of the cruise phase, the Lander batteries were placed on float charge. The charge losses caused the Lander internal temperatures to increase about 9°F while battery temperatures increased 15°F. This was consistent with predictions.

The temperature transients during battery charging and conditioning sequences were quite small and posed no thermal problems. Proper spacing of the sequences was required to avoid a cumulative effect of heating without allowing adequate cooldown periods. Data from the initial conditioning cycles were used to update LTEMP and subsequent predictions were satisfactory. A typical battery charging temperature profile is shown in Figure III-4.

The thermal subsystem again performed nominally during the numerous GCMS and tape recorder maintenance activities. Typical temperature profiles for these operations are given in Figures III-5 and III-6.

8. Science Subsystem

All science instruments were inactive when the Landers were in the cruise mode. Power was supplied to the UAMS and GCMS ion pumps by the BPA to insure vacuum conditions during cruise and proper operation during entry and the landed mission.

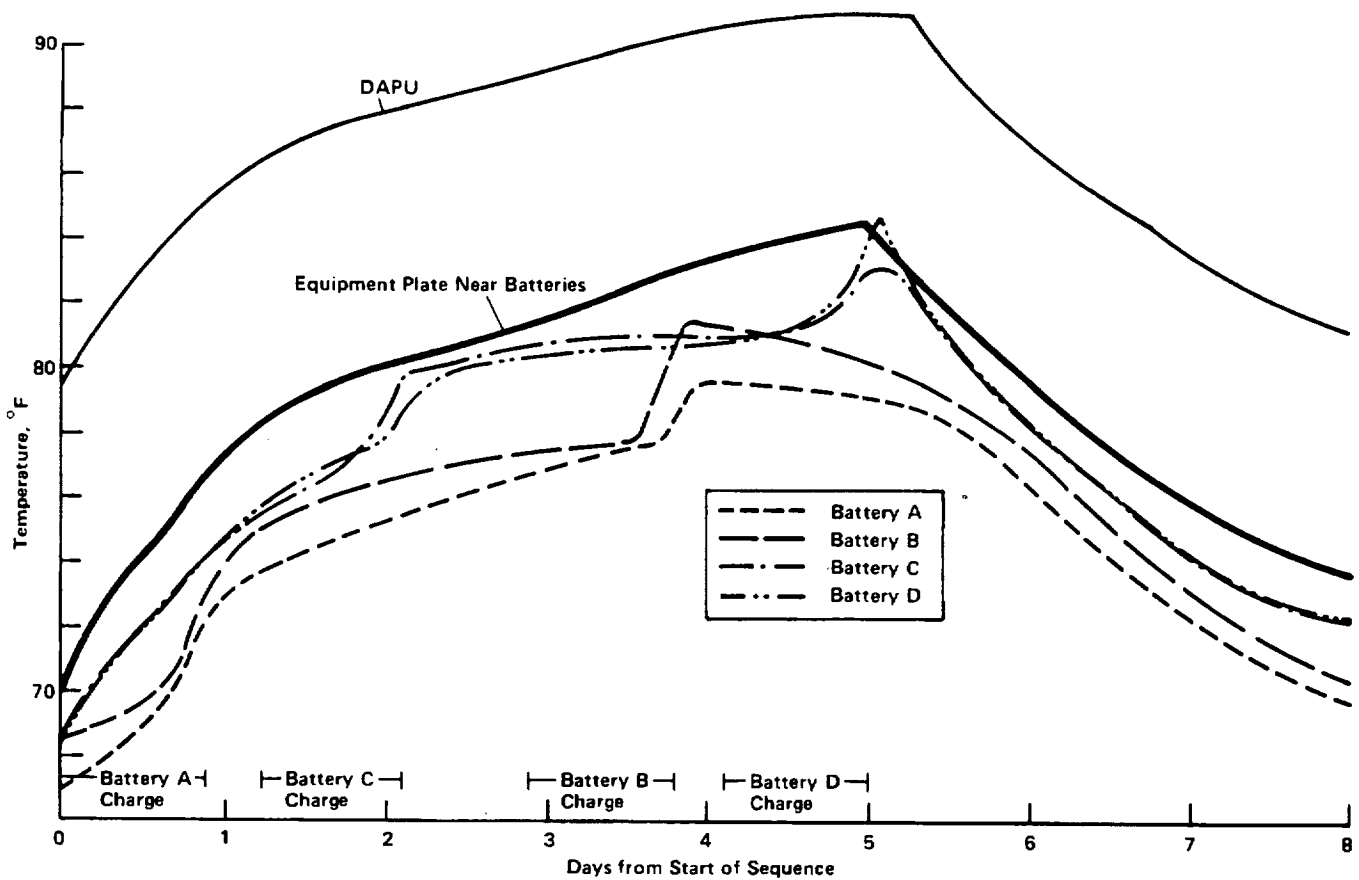

Figure III-4 Typical Lander Internal Temperatures for Battery Charging

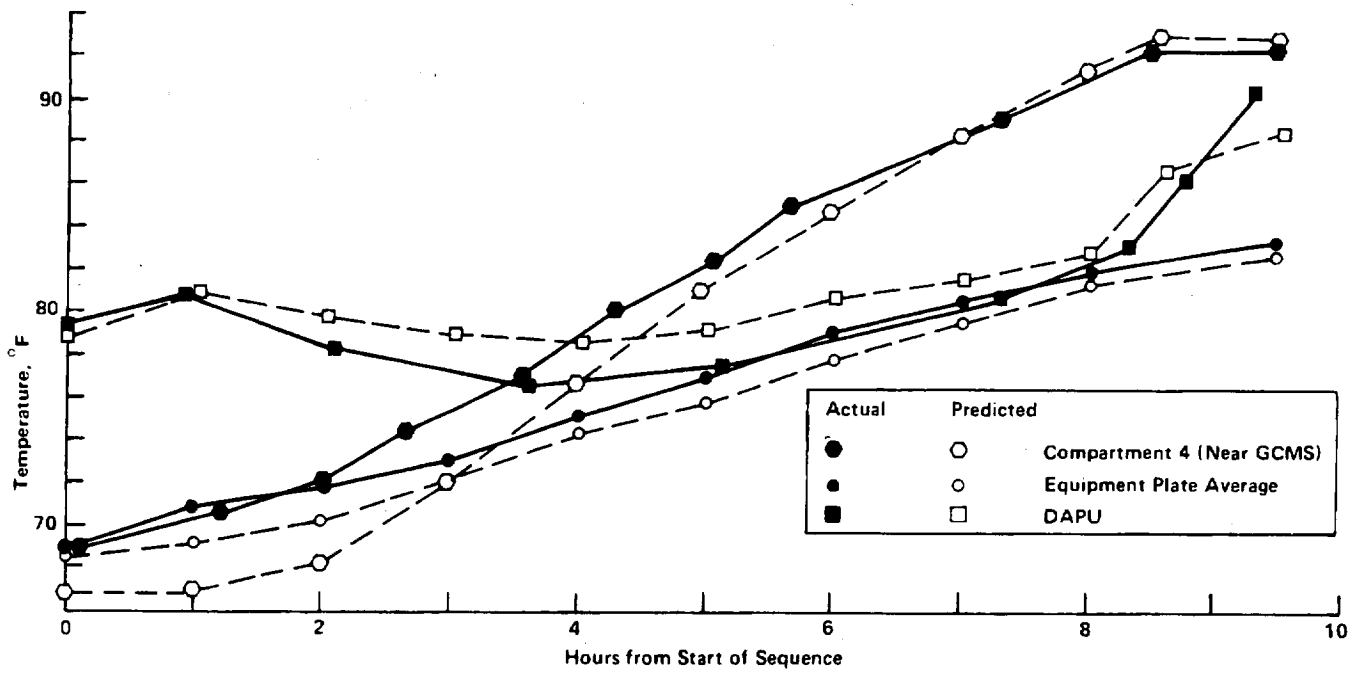

Figure III-5 Typical Lander Internal Temperatures for GCMS Bakeout

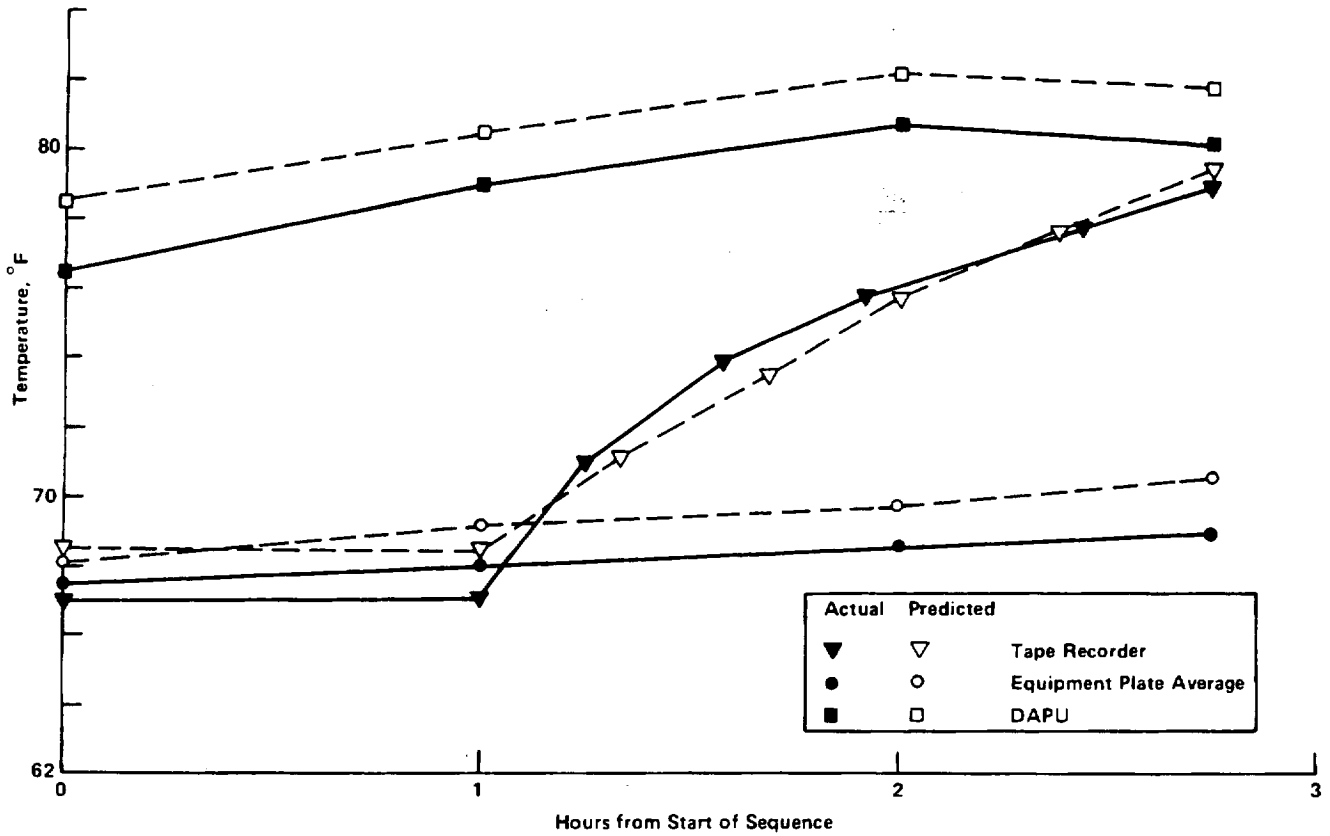

Figure III-6 Typical Lander Internal Temperatures for Tape Recorder Maintenance

B. BATTERY CONDITIONING AND CHARGING

The majority of the cruise phase was accomplished with the batteries fully discharged and the RTGs shorted. In this configuration, power for Lander loads was supplied by the BPA from the Orbiter. During the cruise checkouts and some GCMS operations, Lander loads exceeded the BPA output capabilities. To support these tests, the batteries were charged, the Lander tests conducted, and the batteries then discharged. At the end of the cruise phase, the batteries were conditioned for the separation through landed phases.

To charge each of the four Lander batteries, the GCSC and power control logic in the PCDA was powered on and one battery at a time was connected to the charge bus. The charge enable relays were then closed and the BPA charger commanded on at a constant 0.5 amp high-rate charge mode. Battery charge voltage and temperature were monitored by the charge control logic to stop charging after a full charge was achieved. In addition, the GCSC was programmed to disconnect the battery from the charge bus after 24 hr. Table III-3 provides a summary of charge data for Lander 1.

Table III-3 Lander 1 Initial Battery Charge

Battery on Charge	Charge Time	Input	Final Temperature, °F	Temperature Increase, °F	Cutoff Voltage
A	21 hr 41 min	11.6 A-hr 392 W-hr	72.3	5.4	34.8
B	21 hr 50 min	11.6 A-hr 396 W-hr	79.0	4.0	34.6
C	22 hr 20 min	11.9 A-hr 405 W-hr	81.0	2.8	34.6
D	22 hr 49 min	12.2 A-hr 413 W-hr	84.5	3.1	34.5

Figure III-7 shows the battery voltage and temperature levels used by the charge logic to determine a fully charged battery. Shown are the nominal design cutoff curve and $\pm 1\%$ curves that are estimated equipment and telemetry operating tolerances experienced on the Landers. These data indicate that the Lander 1 and 2 cutoffs were within the expected tolerances and the batteries were fully charged.

With the batteries fully charged, the Lander power subsystem supported the cruise operations that required power in excess of the 150 watt BPA capability. During these operations of from 2- to

25-hr duration, the Lander was transferred to the internal or landed power configuration. In this configuration, the RTGs were unshorted and powered the bus, the batteries were connected to the bus, and the BPA power input was disconnected. Figure III-8 provides data typical of RTG power and thermal changes when the RTGs were powered up and then returned to the shorted cruise configuration. In the landed power configuration, bus voltage was no longer regulated at 33 Vdc, but varied as a function of bus current. At bus currents of less than 2.2 amp, the bus power required was less than the RTG constant power output and the bus voltage rose to turn on the shunt regulators at 36 Vdc. With bus currents greater than 2.2 amp, the power exceeded the RTG output and the bus voltage dropped to the level where the batteries supplied the excess power required. Periodic battery recharge periods were required because the normal landed charge routine was not enabled.

During the initial charging of battery A on Lander 2 by the BPA battery charger, charging was stopped shortly after initiation by Earth command when the very slow voltage increase indicated an unsatisfactory charge condition. A decision was made to resume charging using the redundant BPA charger B as a power source. Battery B was charged first and ground command was used to terminate charge. Batteries A and B were successfully charged in this manner. These data and further analysis isolated the failure to BPA charger A; batteries C and D were then successfully charged using the charge control logic to terminate charge. Charger B was then used for all future charging and no further anomalies were observed. Table III-4 provides the initial Lander 2 battery charging data.

Table III-4 Lander 2 Initial Battery Charge

Battery on Charge	Charge Time	Input	Final Temperature, °F	Temperature Increase, °F	Cutoff Voltage
B	22 hr 34 min	12 A-hr 207 W-hr	83.1	4.9	34.7
A	23 hr 2 min	12.2 A-hr 415 W-hr	85.0	3.6	34.7
C	23 hr 2 min	12.2 A-hr 415 W-hr	88.2	3.5	34.6
D	23 hr 2 min	12.2 A-hr 415 W-hr	91.2	3.3	34.4

As a result of the BPA charger A failure on Lander 2, the normal cruise configuration on both Landers was modified to keep battery B charged.

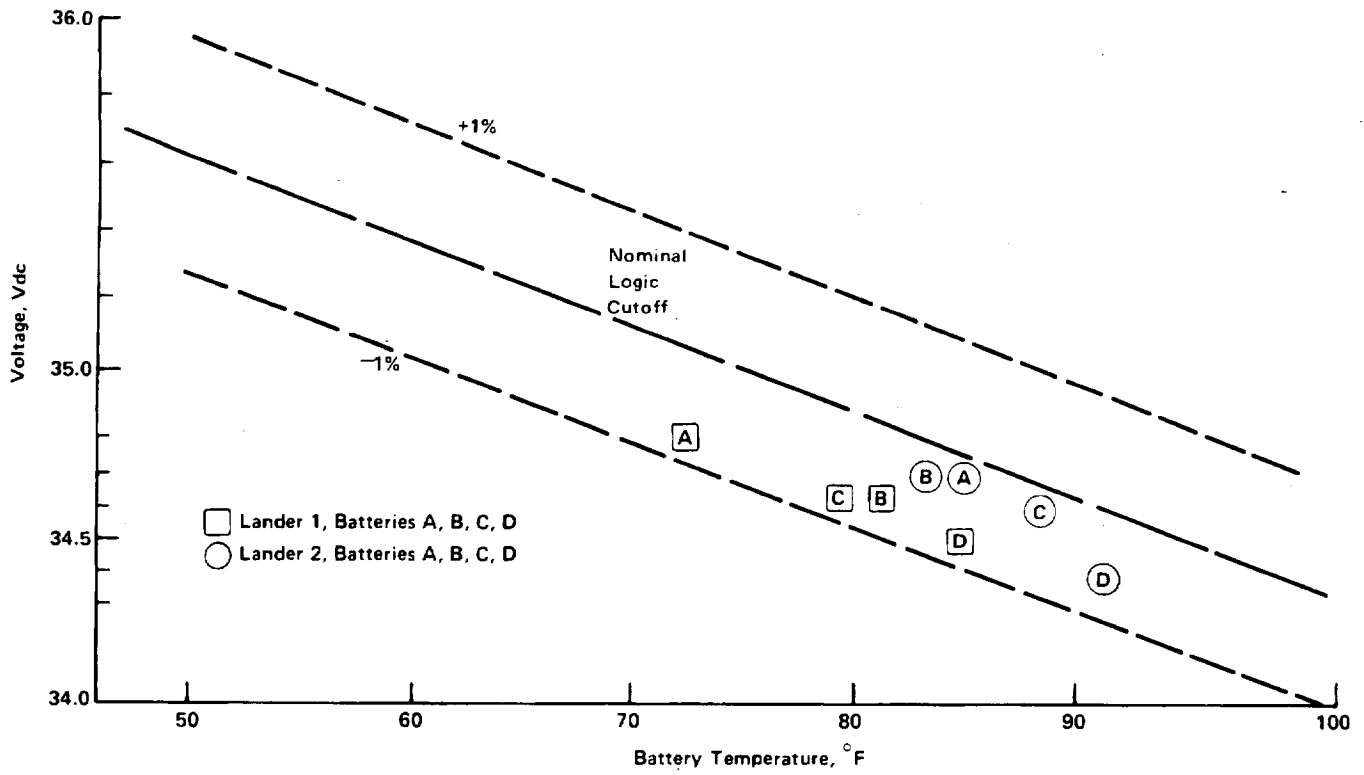

Figure III-7 Battery Charge Cutoff Logic

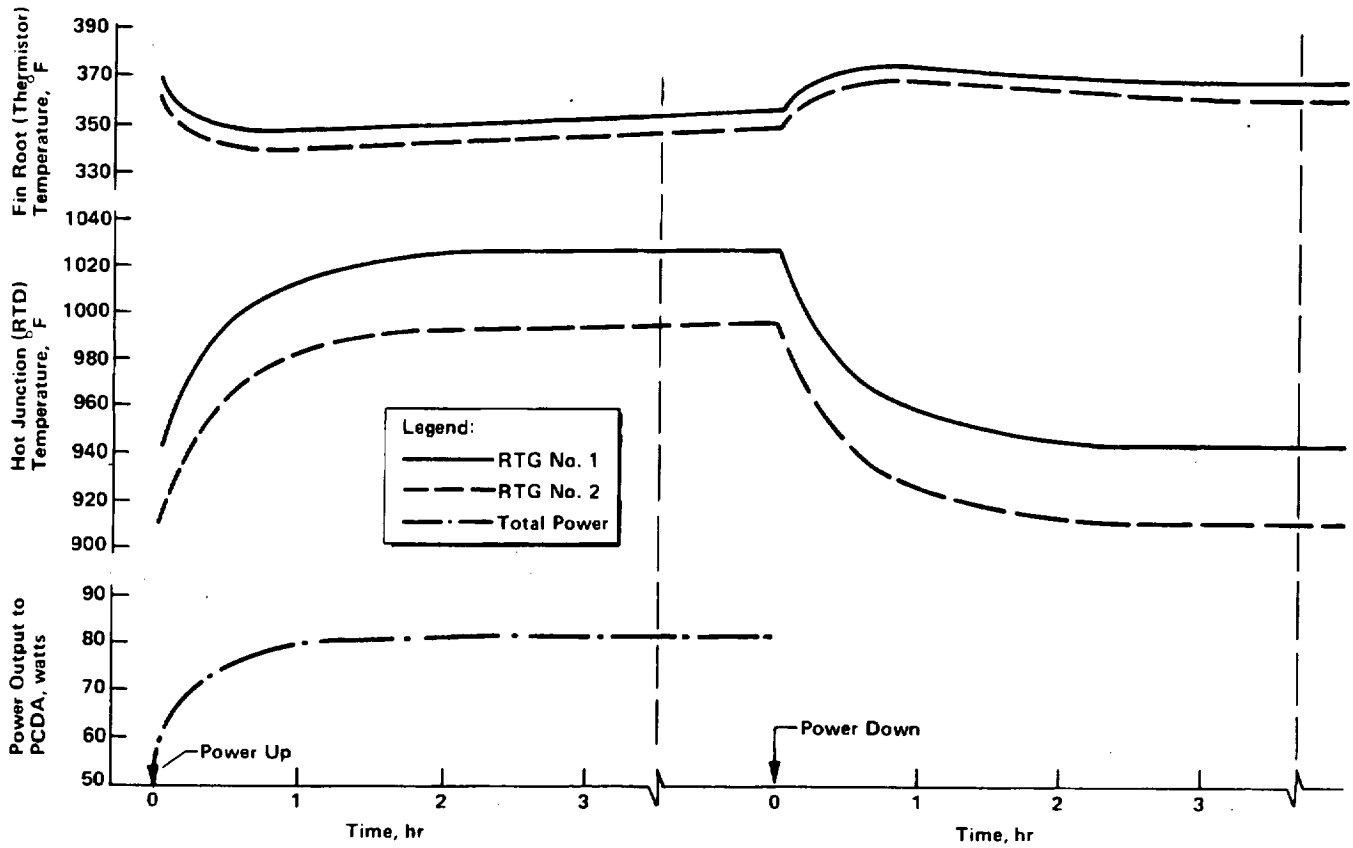

Figure III-8 Lander 1 RTG Transient Data for Cruise Checkout

Batteries A, C, and D were discharged after the cruise tests by the charge bus discharge load banks. These batteries were sequentially discharged down to the PCDA discharge sensor level of 27.3 Vdc. Discharge power exceeded that predicted by about 89 W-hr, indicating actual storage levels and system efficiencies were better than laboratory tests indicated. Batteries A, C, and D were then left to discharge completely, and B was float charged in the 0.2 amp low-rate mode for the remainder of the cruise phase. Battery B voltage stabilized at 34.2 volts and the temperature increased to 88 to 89°F. Batteries A, C, and D discharged down to about 2 volts prior to the final charging for separation.

In May and June 1976, the Lander batteries were conditioned for separation and landing by performing a series of charge, discharge, and charge cycles. These activities were performed to measure and increase battery storage capacity. The Lander 1 and Lander 2 activities are summarized in Tables

III-5 and III-6. Battery B on both Landers had been maintained in a charged state for cruise to enable transfer to internal power and PCDA enabled charging. Therefore, battery B was subjected to an additional discharge/charge cycle. These final conditioning cycles were accomplished using Orbiter power supplied through the BPA. During charging, the charge logic repeated the cruise charge operation and terminated battery charging at 34.5 to 34.8 volts. The discharge logic terminated the discharges at a nominal 27.3 volts. The charge/discharge logic was again backed up by Earth-commanded shutoff in case of a logic failure. All operations were completely nominal with all batteries indicating capacities in excess of 8 A-hr. At the completion of these final conditioning cycles, the batteries were placed on float charge. Seven to ten days before the prepreparation checkouts, the float charge was terminated to allow the Lander to cool down, the battery voltage decreased to 31.4 volts, and temperature decreased to 64.8°F for Lander 1 and 68.5°F for Lander 2.

Table III-5 Lander 1 Final Battery Conditioning

Day of 1976	Event	Battery	Cycle Length, hr	Input/Output, A-hr	End Temperature, °F
114	—	All	Note 1	—	—
114-115	Charge	A	19.85	10.5 In	68.5
115-116	Charge	C	20.0	10.6 In	76.6
116	Discharge	B	6.8	9.9 Out	86.3
117	Discharge	C	6.0	8.7 Out	89.5
Lander Cool Down					
126-127	Charge	B	21.85	11.6 In	75
127-128	Charge	D	21.0	11.2 In	78.2
128	Discharge	A	5.6	8.1 Out	83
129	Discharge	D	6.25	9.1 Out	89.6
Lander Cool Down					
134-135	Charge	A	18.6	9.9 In	71
135	Discharge	B	5.8	8.4 Out	83
Lander Cool Down					
139-140	Charge	C	19.1	10.1 In	73.3
140-141	Charge	B	21.7	11.5 In	84.7
141-142	Charge	D	21.0	11.1 In	84.7
142	—	All	Note 2	—	—
Note: 1. Batteries A, C, and D are completely discharged and at 11.3 V, 8.2 and 11.3 Vdc respectively. Battery B is charged and at 31.7 Vdc. 2. All batteries on C/160 float charge. Stabilized voltage and temperature average was 33.3 Vdc and 80.2°F.					

Table III-6 Lander 2 Final Battery Conditioning

Day of 1976	Event	Battery	Cycle Length, hr	Input/Output, A-hr	End Temperature, °F
136	—	All	Note 1	—	—
136-137	Charge	A	20.87	11.1 In	74.9
137-138	Charge	C	21.1	11.2 In	80
138	Discharge	B	6.6	9.6 Out	90
139	Discharge	C	6.3	9.1 Out	91.2
Lander Cool Down					
144-145	Charge	B	22.5	11.9 In	83.1
145-146	Charge	D	21.2	11.2 In	83.1
146	Discharge	A	5.9	8.6 Out	90
147	Discharge	D	6.4	9.2 Out	93
Lander Cool Down					
156-157	Charge	A	19.4	10.3 In	75
157	Discharge	B	6.2	8.9 Out	86.3
Lander Cool Down					
162-163	Charge	C	20.1	10.7 In	76.6
163-164	Charge	B	22.4	11.87 In	90
164-165	Charge	D	21.1	11.2 In	88
165	—	All	Note 2	—	—
Note: 1. Batteries A, C, and D are completely discharged and at 2.2 V, 1.9 and 2.5 Vdc respectively. Battery B is charged and at 31.4 Vdc. 2. All batteries on C/160 float charge. Stabilized voltage and temperature average was 32.97 Vdc and 82.6°F.					

C. CRUISE CHECKOUT

A cruise checkout was performed on each Lander. These checkouts were identical and very similar to the prelaunch and preseparation checkouts. Preseparation checkout is described in depth in Chapter IV. The following paragraphs briefly describe the tests and results by subsystem. No anomalies were uncovered during either cruise checkout. Because Lander operation was nominal and no unexpected trends were observed, a second scheduled cruise checkout on each Lander was cancelled.

1. Guidance and Control Subsystem

The cruise checkouts were controlled on both Landers from flight software contained in GCSC A. All operations were executed exactly as planned and evaluation of the memories after the checkouts revealed no miscompares.

The IRUs were warmed up and operated and all gyro and accelerometer biases were nominal and essentially identical to prelaunch operation. The warmup and spinup profiles were also nominal.

A TDLR self test was performed and minor beam power variations were noted because of lower than prelaunch TDLR temperatures. All operations were nominal. The RAEs were powered on. All digital and analog data, receiver false alarm rate, and transmitter power were nominal.

2. Power Subsystem

The Landers were switched for the first time since launch to the landed power configuration and internal power was used for battery charging. The RTG output was 81.7 watts for Lander 1 and 83 watts for Lander 2 versus predicted minimum outputs of 75 watts. Battery performance was nominal. The PCDA performed its various switching, conversion, and control functions exactly as required. Actual Lander loads were monitored and were within 0.2 amp of predicted.

3. Telemetry Subsystem

The critical elements of the telemetry subsystem were exercised extensively. The DAPU used 20 different modes during checkout to collect, format, and transmit engineering and science data. Various science and engineering data were stored in and retrieved from the DSM. Data were recorded and played back using all four tape recorder tracks. All operations were nominal.

4. Communications Subsystem

Only the relay communications system was checked out. The UHF transmitter was powered on in the 1 watt mode and formats 2, 2A, 3, and 5 (engineering and science data) were transmitted at 4 kbps and 16 kbps to the Orbiter relay receivers, stored on the Orbiter tape recorder, and transmitted in real time to Earth. All operations were exactly as required with nominal Lander and Orbiter hardware operations. In conjunction with a GCMS bakeout sequence in February 1976, a similar checkout was performed with the UHF transmitter in the 10-watt mode. Again, all operations were nominal.

5. Propulsion Subsystem

Using the VDA, the terminal descent engine throttle valves were commanded to various positions and the RCS and terminal roll thruster feedlines were vented to vacuum. During the RCS vent operation, a higher than expected VDA current was observed. This was caused by operation of the total set of redundant solenoid valves from only one of the two redundant VDA power supplies. The power supplies were designed for such single string operation and all operations were nominal. Since the purpose of the RCS operation was to vent the Earth atmosphere pressure trapped in the feedlines, this portion of the test was not repeated during preseparation checkout. Both LPCA 1 and 2 on both Landers were powered on and monitored. This very limited operation indicated that their internal power supplies were operating properly.

6. Thermal Control Subsystem

Thermal control circuitry used during preseparation (thermal control 2) and entry through landing (thermal control 3) was activated and monitored. All operation was nominal. As a result of various Lander hardware being powered on during the course of the cruise checkout, the Lander internal temperature increased from about 70 to 74°F as predicted.

7. Science Subsystem

Table III-7 lists the science instruments operating during the cruise checkouts and gives a brief sequence description for each of the instruments. The instrument performance follows.

Table III-7 Science Instrument Operation during Cruise Checkout

Science Instruments Operated	Sequence Description
Cameras	Camera 1 and 2 scan verification: check servos and contamination window. Camera 1 and 2 internal calibration: diode response.
XRFS	7 sec count per channel for 64 channels. PC-1, 2, 3, and 4 tested.
Meteorology	10 frames; 4 sec sampling interval. Obtain zero-wind calibration.
RPA	Instrument turned on for 10 minutes during format 2A data acquisition. Measured background noise level in electrometer. Instrument sequencing checked. Retarding grid potential and temperature checked.
UAMS	Instrument turned on for 30 minutes (20-minute warmup, 10-minute data collection): format 2A. Collected mass scans on residual gases in the analyzer plus engineering data.
Ambient Temperature	2 samples/sec for duration of format 3.
Ambient Pressure	1 sample/sec for 10 minutes: format 2A.
Stagnation Temperature	1 sample/sec for 10 minutes: format 2A.
Stagnation Pressure	1 sample/sec for 10 minutes: format 2A.

Lander Camera System—Two sequences were performed on each of the Lander cameras: scan verification and internal calibration. The scan verification sequence provided information concerning azimuth and elevation servo performance and transmittance of the removable outer window. The internal calibration sequence provided data relative to diode response. The cameras on both Landers performed nominally. Scan verification images indicated nominal servo performance. Internal calibration data showed some sensitivity loss in all diodes. The worst case was an 8 to 12% reduction in the infrared diode outputs at gain 2. This corresponds to 3% loss at gain 4 (gain 4 is used for the initial postlanded imagery). Similar sensitivity loss was observed in the scan verification images. During cruise these reductions were believed to be caused by the lower temperatures, but it was later determined that some permanent loss had been sustained because of neutron radiation of the diodes by the RTGs. Over the entire cruise period this damage is estimated at a maximum of 14% for the infrared diodes.

X-Ray Fluorescence Spectrometer (XRFS)—Each of the four proportional counters (PC) were tested whereby the 64 energy channels were read out following a 7-sec count per channel. The pur-

pose of the test was to determine that all proportional counters and instrument functions were operational. The test also provided gain stability data at a low PC tube bias voltage (nominal -50 V). Following sterilization, a gain shift in all four PC tubes was noted where the gains were down 11 to 20%, and the temperature coefficient had increased. Detailed tests and failure analysis of the generic proportional counter showed that with age, the epoxy adhesive inside the PC tube outgassed depolymerization products that acted as a quench gas in the counter. After sterilization the gain immediately began to recover toward its original level. Following the cruise checkouts, all four PCs on each Lander showed an increase in gain and appeared to be stabilizing.

Meteorology—The Lander 1 meteorology instrument performed nominally. Close agreement existed between the platinum thermometer (PTT), ambient temperature sensor (T_a), and footpad temperature sensor (T_{fp}) as indicated by selected data given below:

	PTT, °K	T_a , °K	T_{fp} , °K
Frame 1	246.1	244.5	246.2
Frame 1	246.4	244.3	246.2
Frame 10	246.1	244.4	246.2

The difference between the reference temperature sensor and ambient temperature sensor was less than 10°K, which is the specification value. The ambient sensor was not noisy and the wind sensor overheat circuit operated nominally.

The Lander 2 meteorology instrument operation was nominal with two exceptions: (1) the difference between the reference temperature sensor and the ambient temperature sensor was greater than 10°K, which exceeded specification limits; and (2) the ambient sensor was noisy with a spread of approximately 3°K. These same characteristics were observed during prelaunch checkout. As a result, a series of additional checkouts on both the Lander 1 and 2 instruments were conducted during the cruise phase to determine if a pattern could be uncovered or if stabilization occurred. Table III-8 lists the checkouts on each Lander (performed in conjunction with tape recorder maintenance) and gives a brief sequence description. Throughout these checkouts the Lander 1 instrument remained stable in performance and satisfied all performance criteria. The ambient temperature sensor on Lander 2 continued to exhibit erratic behavior

Table III-8 Meteorology Checkouts during Cruise Phase

Lander	Date	Sequence Description
1	12/8/75	10 frames; 1-sec sampling interval
	1/5/76	15 frames; 2-sec sampling interval
	3/9/76	15 frames; 1-sec sampling interval
	4/17/76	30 frames; 2-sec sampling interval
2	12/4/75	15 frames; 1-sec sampling interval
	1/7/76	15 frames; 2-sec sampling interval
	2/3/76	10 frames; 4-sec sampling interval
	3/10/76	30 frames; 1-sec sampling interval
	4/16/76	30 frames; 2-sec sampling interval
	5/9/76	20 frames; 4-sec sampling interval

with the difference between it and the reference sensor ranging from 14.5 to 20.0°K throughout the checkouts. The ambient temperature noise continued, with the Lander 2 sensor noisier than the Lander 1 sensor by a factor of 1.5 to 3.

Entry Science Instruments—The RPA, UAMS, ambient and stagnation temperature sensors, and ambient and stagnation pressure sensors were operated during the cruise checkouts for both Landers. All instruments performed nominally.

D. GCMS VENT, BAKEOUT, AND OVEN CHARACTERIZATION

A series of GCMS activities were planned for the cruise phase of the Viking mission. The ultimate goal of these activities was to prepare the GCMS for performing the organic and atmospheric

analyses on the surface of Mars. Specifically the GCMS sequences were designed to:

- 1) Vent the two inlet systems that go to the mass spectrometer, the gas chromatograph assembly (GCA), and the atmospheric filter assembly (AFA) to space, thereby reducing the level of the terrestrial gasses within the sample paths.
- 2) Bake out the components of the GCA and the ion source of the mass spectrometer to further reduce the instrument background.
- 3) Characterize the sample oven to be used for the analyses of the first surface sample on Mars by performing a "blank" organic analysis by heating that oven to 500° while it is sealed in the sample path.
- 4) Obtain background spectra from the mass spectrometer for both filaments and both ionizing energies following the last bakeout of the ion source.
- 5) Perform sequences that permit identification of problems that were encountered by the instruments during prelaunch activities or during planned cruise activities.

Eleven sequences were conducted on the Lander 1 GCMS. Table III-9 summarizes these activities and the GCMS performance. Seven sequences were performed on the Lander 2 GCMS. Table III-10 summarizes these GCMS activities and the instrument performance. A more detailed summary of the anomalies that occurred is given below.

Table III-9 Lander 1 GCMS Cruise Operations

Sequence	GCMS Event	Sequence Description	Date	Performance
1	Vent 1	Vent LPA/PDA, AFA, GCA	10/30/75	Off-nominal: ion pump turn-on transient
2	Ion Pump Test	Correlate ion pump restart with Vent 1 anomaly	11/17/75	Nominal
3	Research Test 1	Vent GCA, AFA; heat GCA zone	12/10/75	Nominal
4	Research Test 2	Obtain background MS data	12/15/75	Nominal
5	Bakeout 1	Heat ion source and thermal zone; vent GCA and AFA	1/8/76	Nominal
6	Bakeout 2	Heat ion source and thermal zone; vent GCA and AFA	1/14/76	Nominal
7	Oven Characterization 1	Preheat oven 1; organic analysis	1/29/76	Nominal
8	Oven Characterization 2	Preheat ovens 1 and 2; OA	2/2/76	Nominal
9	Bakeout 3	Heat ion source	2/7/76	Nominal
10	Bakeout 4	Heat ion source	2/12/76	Nominal
11	Vent 4/5	Vent AFA sample chamber, CO/CO ₂ filter chamber, H ₂ O filter chamber; atmospheric analysis; reposition oven carriage	2/17/76	Nominal

Table III-10 Lander 2 GCMS Cruise Operations

Sequence	GCMS Event	Sequence Description	Date	Performance
1	Combined Vent	Vent LPA/PDA, HSA, AFA, GCA	11/25/75	Nominal
2	Open VO/Bakeout 1	Open hydrogen inlet valve; heat ion source and thermal zone; vent GCA, AFA	12/3/75	Nominal
3	Oven Characterization 1	Preheat oven 1; organic analysis	12/19/75	1) Oven time-to-temperature reached maximum value during preheat and OA; 2) Loss of mass scan data
4	Oven Characterization 2	Preheat ovens 3 and 1; organic analysis	1/13/76	Oven time-to-temperature reached maximum value during preheat and OA (oven 1)
5	Oven Characterization 3	Preheat oven 2; organic analysis	1/21/76	Nominal
6	Bakeout 2	Heat ion source	1/31/76	Carriage strobe anomaly*
7	Vent 4/5	Vent AFA sample chamber, CO/CO ₂ and H ₂ O filter chambers; atmospheric analyses	2/6/76	Carriage strobe anomaly

*Not identified until Vent 4/5.

1. Lander 1 GCMS Anomalies

On Lander 1 only one anomaly occurred during vent 1 (sequence 1). After a 2-hr power interruption the ion pump current peaked at 23 μ A decreasing to 1.3 μ A over a 50-minute period. As a result of the ion pump test and Research Tests 1 and 2 (sequences 2, 3, and 4), it was determined that the ion pump was capable of handling the loads from a bakeout and oven characterization. No long-term problems resulted from this anomaly. Following the oven characterizations on Lander 2 (sequences 3, 4, and 5) an analysis of prelaunch Lander 1 GCMS data indicated that oven 3 on Lander 1 exhibited the same time-to-temperature anomaly as experienced on Lander 2. Consequently, it was concluded that oven 3 was inoperable and two surface samples were scheduled for the Lander primary mission using ovens 1 and 2.

2. Lander 2 GCMS Anomalies

On Lander 2, three anomalies occurred.

- 1) The time-to-temperature counter reached a maximum value during the preheat of oven 1 and the subsequent organic analysis (sequences 3 and 4). As a result, it was concluded that oven 1 was inoperable and two surface samples

were scheduled for the Lander 2 primary mission using ovens 2 and 3.

- 2) During oven characterization 1 (sequence 3) the 20:1 divider shifted its conductance in the vicinity of 100:1. Since the sequence was run in the hydrous mode, mass scan data were lost. Future oven characterizations were run in the anhydrous mode, and this problem did not recur.
- 3) During backout 2 (sequence 6) the carriage strobe signal changed states and remained invalid. This anomaly became apparent during the vent 4/5 sequence (sequence 7) when the seal clamp and carriage movements failed to execute because of the position and state validity checks encoded into their command words. No corrective actions were taken during the cruise mission. However, the Lander 2 initial computer load (ICL) was modified to schedule a sol 1 sequence which: (1) backed up the carriage to position 1 (flight station position); (2) forward indexed the carriage to position 2 (load position); and (3) performed a dummy load operation. The purpose of this sequence was to verify as early as possible following touchdown that the load position could be acquired and that the load would occur normally without moving the carriage. These sequences ran nominally.

ORIGINAL PAGE IS
OF POOR QUALITY

IV. PRESEPARATION PHASE

- A. Preseparation Checkout
- B. Preseparation Battery Charging
- C. Separation - 9.5-Hour Update
- D. Separation - 3.5 Hours to Separation

These two photographs were taken from Lander 1 using camera 1 on July 24 (left photo) and camera 2 on July 21, 1976 (right photo). A stereo effect may be achieved if viewed through a standard stereo viewer.

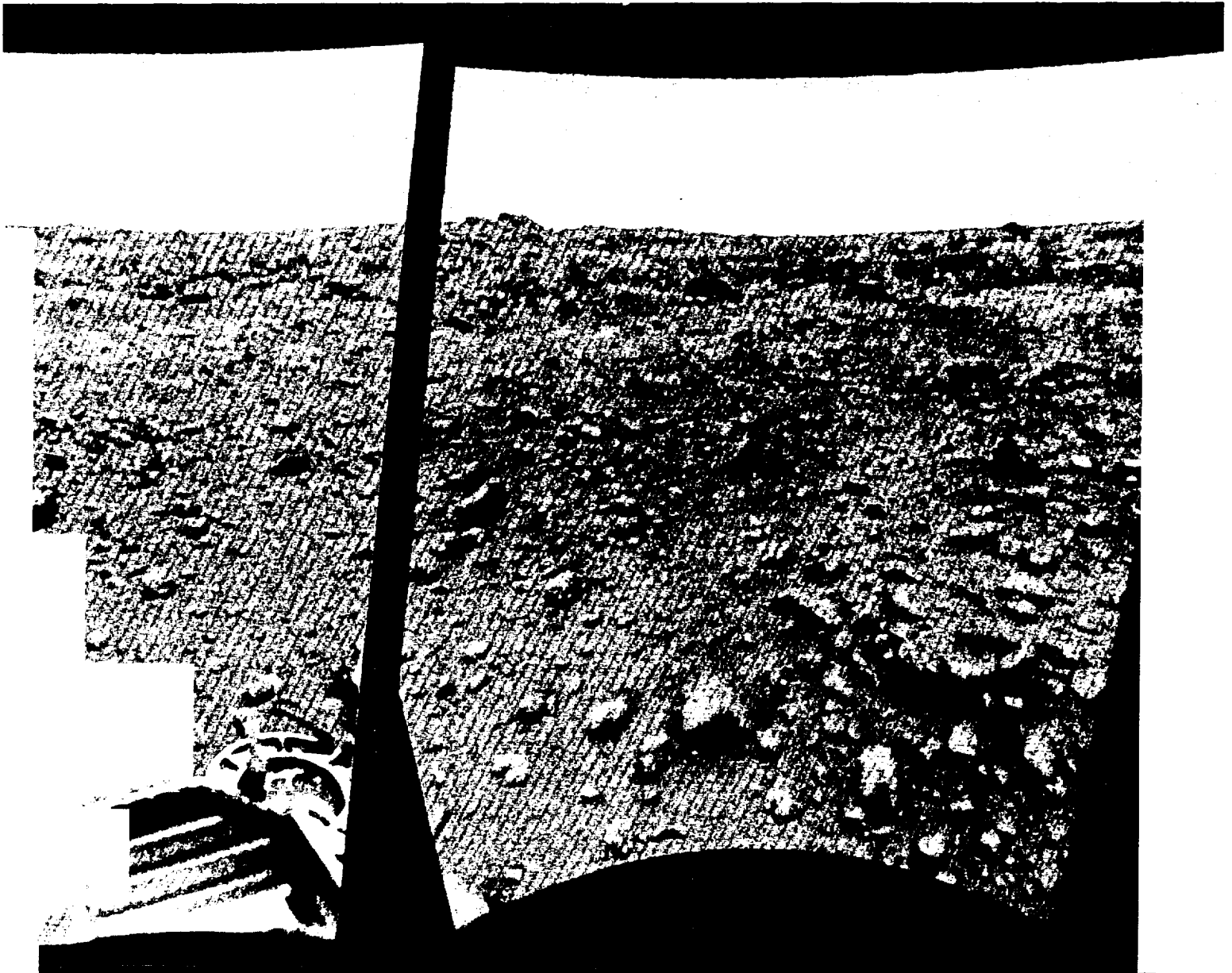

IV. PRESEPARATION PHASE

The preseparation phase was one of the most active and time-critical periods of the Viking mission for both the Landers and the flight team. In this period, many activities had to be performed flawlessly at exactly the required time to permit the eventual separation of the Landers from the Orbiters and landing on Mars on the selected day. The Landers had to function and sequence accurately through a series of tests and updates before being committed to separation.

A timeline of the preseparation phase showing the major events for the Lander, Orbiter, and flight team is shown in Figure IV-1. Figure IV-2 shows where these events occur relative to the spacecraft's orbit about Mars and the descent trajectory. The preseparation phase is defined as the time period from separation minus 62 hr to separation (S - 62 hr to S - 0).

Once the selection of a landing site and day of landing was made, the flight team prepared the set of parameters needed to update the GCSC memory with the descent trajectory design. A critical element of the preseparation phase was the validation of the descent design. This was done by two independent methods. One was a ground software program run at the Jet Propulsion Laboratory at Pasadena, California. This was a complete digital simulation of the Lander attitudes and trajectory dynamics for the entire descent with external effects (such as Mars atmosphere) also simulated. The other method used the Viking Control and Simulation Facility (VCSF) at the Lander Support Office

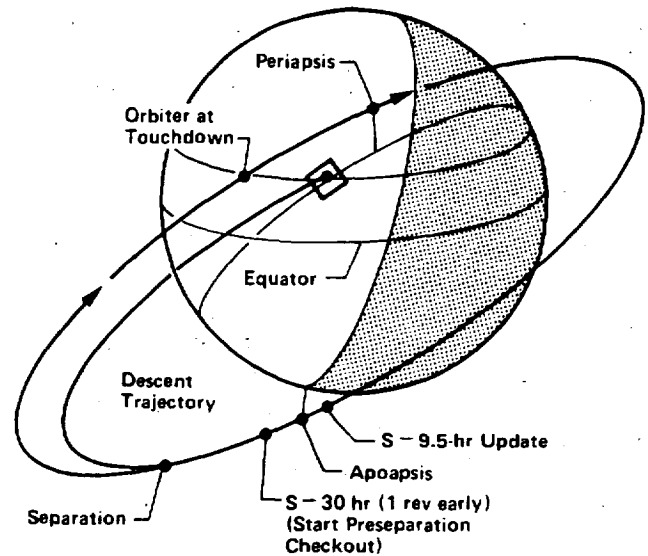

Figure IV-2 Preseparation Sequence of Events

(LSO) in Denver, Colorado. This highly sophisticated analog/digital hybrid computer laboratory "flew" a simulated descent with a computer model of the Lander and planet. This simulation was complete down to the flight computer instruction level. The transfer of data to and from the VCSF and JPL was accomplished via a high-speed data line. After verifying that all details of the separation and descent command loads were proper, the Lander computers were updated during the S - 39-hr update period. Also, the Orbiter onboard computer was updated with its required sequence for the pre-separation through descent phase.

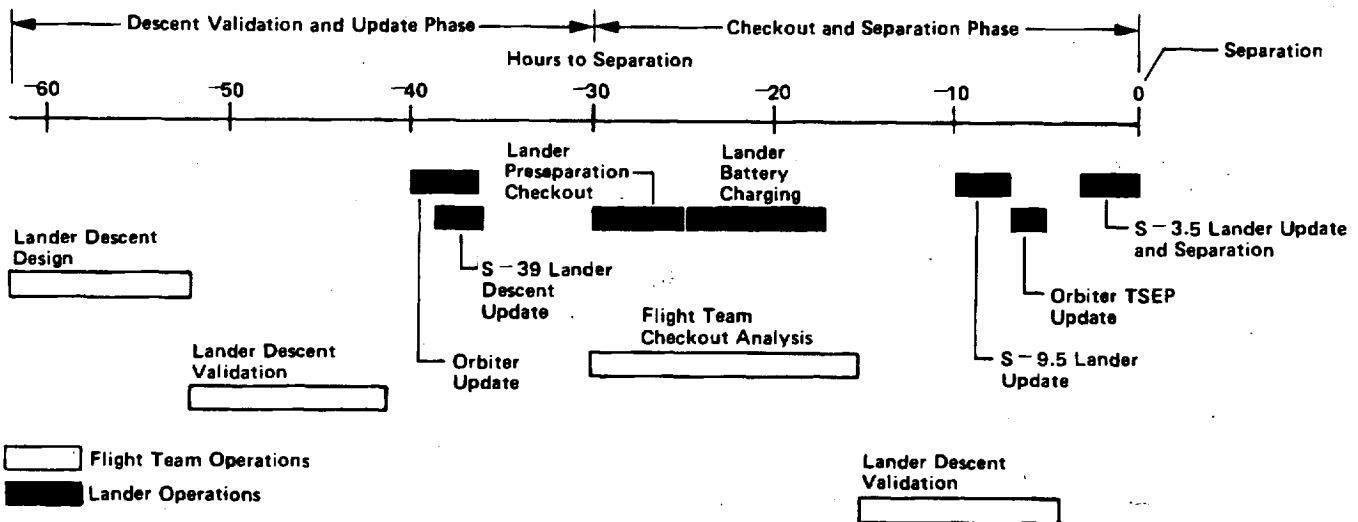

Figure IV-1 Preseparation Phase Timeline

A major milestone in the preseparation phase was the commitment to start the S - 30-hr preseparation checkout. This checkout consumes so much power and generates so much internal heat, that a "no-go" for separation any time after the checkout would have required a five-day waiting period for the Lander to stabilize thermally before the checkout sequence could be performed again. The objective of the checkout sequence was to calibrate and verify the operation of the critical entry and landing hardware on the Lander. When the checkout sequence was complete, Lander battery charging was begun to restore full battery electrical capacity and the flight team started a detailed analysis of the preseparation checkout results. If analysis indicated that any late flight software updates were required, the capability was provided by a S - 9.5-hr update period. If any changes were made, this would require validation by the aforementioned methods to insure the changes would not in any way impact the descent design. Also, by this time the flight team would have determined if any change to the selected time of separation was necessary and capability to accommodate this change was provided as shown on the timeline (Orbiter TSEP Update).

The final element of the preseparation phase was the S - 3.5 hr to separation sequence. In this period, another capability to make minor updates to the GCSC was provided. This capability was not exercised on either Lander. Also in this period, all the final checks were made on Lander subsystem status before a commitment for separation was made. On both missions, these final checks indicated nominal Lander performance and readiness for separation. A "Separation Go" command was then sent to the Landers to allow separation and start the descent phase.

A. PRESEPARATION CHECKOUT

The basic intent of the preseparation checkout was to check systems that were critical for descent through landing and those operations necessary immediately after landing. This included checking systems that contained redundancy or selectable operating modes to determine if any change was necessary to the preprogrammed selections. Additionally, some subsystems provided the capability for in-flight calibration.

The preseparation checkout sequence was begun by the Orbiter issuing a series of discrete commands to the Lander that turned on the PCDA

power supplies and the GCSC side A. (Even though both GCSC sides on both Landers had performed equally well up to this time and either side could have been used, side A was preferable for software and Lander/Orbiter interface considerations.) At exactly S - 30 hr, the preseparation checkout command was sent from the Orbiter. The Lander responded by transferring to internal power and initiating the preseparation thermal mode. The GCSC also started the 4 hr 40 min automatic checkout sequence. The data were telemetered during the test via the Orbiter to the ground for flight team evaluation. There was no on-board evaluation of the data. The test consisted of 11 checkout modules that were sequenced under direction of the GCSC and concluded with a complete memory readout of the GCSC. These modules were the Lander camera system, meteorology, biology, XRFS, entry science, RCE, VDA, IRU, TDLR/RAE, RAE CFAR, and telemetry. A description of each module, with results from both Landers, is given below. Although there were no checkout modules for the Lander power or thermal subsystems per se, they were tested by virtue of executing the other modules.

A timeline of this sequence is shown in Figure IV-3. As can be seen, each test was sequenced essentially serially with some functions occurring in parallel.

1. Camera Module

The purpose of the Lander camera test was to verify the scan capability and diode integrity of each camera. Since the GCSC had been preprogrammed to use camera 2 for the first pictures immediately after touchdown, it was important to know the status of that camera. The health of camera 1 was also important if camera 2 performance indicated a need to change the camera selected for the first pictures. Additionally, knowledge of diode characteristics was necessary to assure the preselected camera gain and offset selections were correct for the expected Mars lighting conditions.

The camera test consisted of turning on thermal power for warm-up purposes and later turning on operating power on each camera sequentially. During the periods when each camera was on, a series of scan, calibration, and stow commands were issued by the GCSC. The scan verification sequence consisted of taking a 5-deg azimuth picture of two pin lights mounted on the camera post.

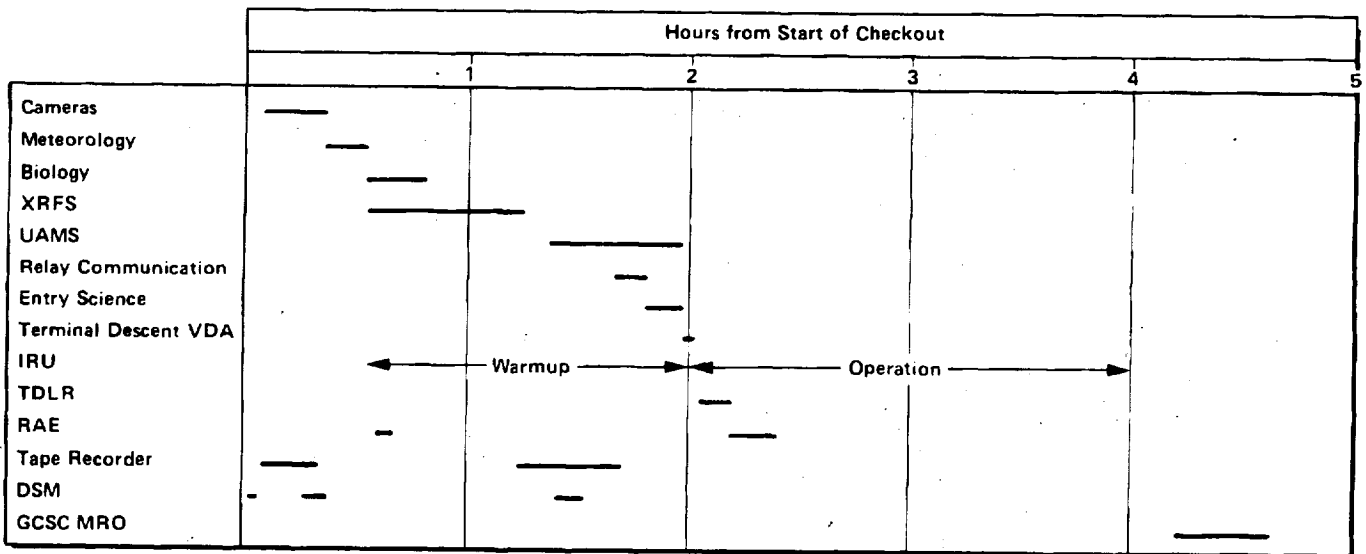

Figure IV-3 Lander Component Operation during Preseparation Checkout

Not only did this verify both azimuth and elevation scanning, but analysis of the pin light intensity was a check on any outgassing product condensation on the camera's external window since launch. The camera diodes were checked by an internal calibration sequence that consisted of exposing the cameras' 12 diodes to an internal pinlight and checking 11 of the 12 diodes' response and noise level. The twelfth diode, designed for imaging the sun directly, shows no response to the pin light and is therefore not checked by this sequence.

Camera data from both Landers indicated that the cameras had received minor damage from neutron radiation from the RTGs as expected. This was reflected in both the internal calibration and scan verification data, which showed a reduction in camera sensitivity (from prelaunch tests) of up to 12% at the commanded gain. However, the above changes were not significant enough to update the preprogrammed camera parameters.

2. Meteorology Electronics Assembly (MEA) Module

The purpose of the MEA test was to verify that the meteorology electronics and sensor assemblies were operational, and also to obtain a wind and temperature calibration in a zero-wind and relatively stable temperature environment. Approximately 11 minutes of meteorology data were acquired, consisting of wind/temperature samples at 4-sec intervals in response to GCSC commands.

The Lander 1 meteorology instrument performed nominally and similar to that during cruise checkouts. The difference between the MEA reference temperature sensor and the ambient temperature sensor was less than 10°K. The Lander 2 meteorology instrument, however, continued to show the same erratic behavior as exhibited during the cruise checkouts. The difference between the MEA reference temperature sensor and the ambient temperature sensor was greater than 10°K, which exceeded the specification value, and the ambient sensor remained noisy.

3. Biology Module

Two sequences were performed on the biology module: (1) the valve matrix driver was cycled four times to ensure that the relays controlling the valves were functioning properly; and (2) several valves were closed to prevent contamination of the internal passages from Lander exhaust gases during terminal descent.

The instrument performed nominally and no updates due to preseparation checkout were required before separation. However, on Lander 2 one biology sequence update was made at S - 9.5 hr (refer to Section C of this chapter).

4. XRFS Module

The XRFS test consisted of a calibration of each of the four proportional counters (PC),

whereby the 64 energy channels are read out following a 7 sec count per channel. The purpose was to verify proper gains and voltages for the sol 0 calibration on the Martian surface. On Lander 1, the data showed a 10% drop in PC-1 and PC-3 gain from cruise checkouts. As a result, a change in the nominal voltages to be used for these tubes after landing was uplinked at S - 9.5 hr (refer to Section C of this chapter). On Lander 2, the XRFS performed nominally. The gains had stabilized at pre-sterilization values.

5. Entry Science Module

Table IV-1 summarizes the entry science instrument operations during preseparation checkout. All instruments continued to operate nominally as they did during the cruise checkouts.

Table IV-1 Entry Science Instrument Operation during Preseparation Checkout

Instruments	Sequence Description
RPA	Instrument turned on for 10 minutes during format 2A data acquisition. Data measured background noise level in electrometer. Instrument sequencing checked. Retarding grid potential and temperature checked.
UAMS	Instrument turned on for 30 minutes (20-minute warm up, 10-minutes data collection), format 2A. Collected mass scans on residual gases in the analyzer plus engineering data.
Ambient Temperature	2 samples/sec for duration of format 3.
Ambient Pressure	1 sample/sec for 10 minutes, format 2A.
Stagnation Temperature	1 sample/sec for 10 minutes, format 2A.
Stagnation Pressure	1 sample/sec for 10 minutes, format 2A.

6. Relay Communications Equipment (RCE) Module

The RCE test was a verification of the capability to transmit data via the relay link from the Lander to the Orbiter. The results of this test were important since the relay link is the prime return path of entry and landed science and engineering data.

The RCE has three output power operational modes: 1, 10, and 30 watts. Only the 1- and 10-watt modes could be checked in the preseparation checkout because of concern for Orbiter receiver damage in the presence of the signal level produced by the 30-watt mode. All of the real-time engineer-

ing telemetry data formats and the two data rates (4 and 16 kbps) that would be used during descent and landed operations were transmitted by the RCE to the Orbiter receiver and stored on the Orbiter tape recorder. Additionally, the 4 kbps data were fed directly through the Orbiter and transmitted to Earth in real time. The Orbiter recorded data were played back to Earth at 4 kbps immediately after preseparation checkout, completely simulating a postlanded relay link. As an additional benefit, the recorded data could then be compared to the real-time feedthrough data as a check on the Orbiter recording system. The results of the test for both Landers were that all RCE engineering measurements were as expected and the same as measured during the cruise checkout. The test demonstrated that the complete link from the Lander through the Orbiter to Earth functioned as expected. The data recorded on board the Orbiter, which was played back, compared exactly with the data received in real time. The test showed that the RCE performed perfectly in all commanded modes and was ready for separation.

7. Terminal Descent Valve Drive Amplifier (VDA) Module

The terminal descent VDA test was an operational and functional integrity test of the terminal descent engine throttle valves and driving electronics. The reaction control deorbit system (RCS)/VDA was not checked because it contained passive nonselectable redundancy. After VDA power on, all three terminal engine valves were commanded simultaneously on 3-sec intervals to 10 preselected positions (50%, 10%, 30%, 50%, 70%, 90%, 70%, 50%, 30%, and 10%). Results were verified by comparing the commanded position against the actuals from the returned telemetry. Only a gross check of valve response or any overshoot was possible due to the telemetry sampling rate; however, results from both Landers showed extremely accurate commanded versus actual positions and an overall successful test.

8. Inertial Reference Unit (IRU) Module

Due to the criticality for descent, the IRU inertial sensors, electronics, and thermal system underwent a detailed evaluation. After an 88-minute thermal power warmup, operating power was applied to IRU inertial sensor and electronics string 1 with gyro spin-up time and power consumption verified to be within limits. One minute later, a high-rate test was performed. If this test were to

fail, this string would be powered off, IRU string 2 powered on, and the same test performed again. This did not occur on either Lander and string 1 remained prime. Then, a 2-hr stabilization and calibration period was begun with the Orbiter maintaining sun-Canopus lock, thus providing a stable reference. During this 2-hr period, the GCSC sampled all eight sensors at 20 msec intervals, accumulated these samples, and provided the data accumulations at a 200-msec rate to the downlink telemetry. These data were then compared with the Orbiter's IRU data over the same time period to filter out Orbiter limit cycle motion. The gyro and accelerometer biases repeated the values determined in cruise checkout so closely that no change was required to the preprogrammed compensation values. An apparent bias instability of the Y-axis gyro on Lander 2 was observed, but was determined to be an Orbiter celestial sensor scale factor error. At the conclusion of the 2-hr calibration period, the high torque load was tested. The torque test applied a calibrated torquing function to the IRU gyros and the resulting rate function was evaluated for proper response. After this test and before removing power, a power redundancy and fuse bypass test was performed. In this test, relays were cycled to check redundant power paths, and relays used to bypass the thermal and operate power fuses during descent were cycled. All aspects of this exhaustive and thorough test of the IRU were very nominal for both Landers.

9. Radar Altimeter Electronics (RAE) Constant False Alarm Rate (CFAR) Module

The RAE CFAR test was basically an RAE receiver health check. Each RAE was powered for 1 minute and the CFAR measurement monitored. The CFAR measurement is an analog voltage versus level of threshold increase sampled near the end of the intrapulse period (where a target return would not occur). This gave a measure of receiver amplification and also determined that no excessive noise existed in the system. RAE power output was also checked while each RAE was powered. Both RAEs on both Landers passed this test with values well within expected limits.

10. Terminal Descent and Landing Radar (TDLR) RAE Module

The TDLR and RAE tests were run sequentially and in parallel with the IRU calibration. Not

only were these functional tests of the radars themselves, but since radar data are acquired by the GCSC and then passed to the telemetry system, the radars/GCSC interface was also verified.

Starting the 6-minute TDLR test, power redundancy was checked by applying power to one power supply string, then the other. Transmitter power output was measured throughout the test in all four channels. A self-test mode was then commanded, which caused the TDLR to generate an internal 10 kHz test signal (equivalent to approximately 370 ft/sec). Verification was obtained that all four TDLR beams acquired lock and read the correct velocity. "Tracker Lock" and "Data Good" discretes to the GCSC were also verified for the correct state. An "Altitude Mark" command was issued while locked and verification obtained that the TDLR remained locked. The self-test command was then removed and verification made that the TDLR unlocked and searched in a lower velocity range in response to the "Altitude Mark" command. Then the "Altitude Mark" command was removed and a 5-minute "False Lock" test was run with the TDLR searching in the higher velocity range. TDLR performance on Lander 1 was nominal in all respects with all parameters well within the tolerance of expected values. Lander 2 was also nominal except for a series of four anomalous tracker acquisitions in channel 2 during the "False Lock" test. There were insufficient data to isolate the cause of the anomaly; consequently a decision was made to exercise the preprogrammed option of commanding the GCSC in the S - 9.5-hr update period to ignore the channel 2 data during descent. Only three of four TDLR beams must operate properly for a successful descent.

Each RAE has four operational modes corresponding to different altitude search ranges starting at mode 1 for the highest altitude to mode 4 for the lowest. In the test, RAE 1 was powered on and each mode initiated at 1-minute intervals. Verification was made of tracker searching with no false locks. In mode 4, tracker lock at minimum altitude was expected due to reflections within the encapsulated Lander. At that time, a "breaklock" command was issued five times at 2-sec intervals, verifying that function. The same test was duplicated for RAE 2. RAE performance on both Landers during these tests revealed no change or degradation in operating characteristics since prelaunch.

11. Telemetry Module

Only specific aspects of the telemetry subsystem were checked in this module, namely tape recorder and data storage memory (DSM). However, extremely thorough checkout of the total telemetry system was obtained by virtue of the various telemetry modes used throughout the preseparation checkout. All engineering formats were used except one (format 4, a landed telemetry format), and all science formats were acquired for which there was a science test. In addition, all telemetry rates were checked except for the three lower landed rates (500, 250, and 8-1/3 bps). In the telemetry module itself, the tape recorder and DSM were checked using data from the science module tests which simulated the landed mission. The tape recorder was powered and conditioned to a known tape position so that when the test was complete, the tape position would be that desired for recording descent telemetry—the next planned usage of the tape recorder. Camera 1 data were first recorded on track 1 in the reverse direction at 16 kbps; then camera 2 data were recorded on track 2 in the forward direction at 16 kbps. These data were subsequently played back at 1 kbps. Since bit errors can be easily seen in imaging data, this test provided visibility of the tape bit error rate as well as functional performance of the recorder. Both Lander 1 and 2 tape recorders performed exceptionally well with negligible bit errors. The DSM was tested by writing the meteorology, biology, and XRFS data from their module tests into the DSM with subsequent complete DSM readout. Since these data only partially filled the DSM, "old" data that were in the DSM from cruise testing were read out also. This provided confidence in DSM memory retention over time. The results from both Landers indicated bit error-free data.

12. Power Subsystem

When the preseparation checkout command was given, the power subsystem underwent a significant planned change. The power transfer switches in the PCDA were activated and the Lander RTGs unshorted. The RTG power level began to rise immediately to about 50 watts, then slowly to the full power output of 81.5 to 84.5 watts in 1 hr. The Lander equipment, which was powered from the BPA, was now powered by the converted RTG power. All RTG temperatures, pressures, currents, and voltage levels were right on the predicted performance curves. To conserve battery energy, the

thermal control system heaters were still powered from the BPA and continued this way until 30 sec prior to separation. From a power subsystem standpoint, all loads were properly turned on and off at the specified times and the power levels were within 5% of predicted values. During high current load periods, current sharing between the four batteries was checked and was well within the acceptable variations of 20%.

A ground computer program called LPWR that was used throughout all phases of the Viking mission to predict the Lander power subsystem status was employed to predict use of battery-stored energy during the preseparation checkout. An LPWR plot of the Lander load and the total battery state-of-charge (SOC) versus time is shown in Figure IV-4. A few representative actual Lander 1 data points are shown.

13. Thermal Subsystem

The response of the thermal subsystem during preseparation checkout was of interest for several reasons. Successful operation of the terminal engine pyrotechnic valve 2 thermostatic heater and the deorbit and terminal descent engine continuous heaters was required to ensure proper propulsion subsystem operation. The temperature profile of individual components as they were powered during the sequence served as additional verification that the component was functioning properly. Confirmation that the thermal subsystem as a whole was responding as expected was required to give confidence in the ground thermal computer model (LTEMP) predictions. This was particularly important because the touchdown temperatures of several components were predicted to be quite close to flight acceptance limits.

All Lander temperatures responded as expected during preseparation checkout and were very similar to those experienced during the cruise checkouts. At the end of the sequence, the Lander internal temperatures were generally within 1 to 2° F of predictions (generally cooler), thus giving confidence in the subsequent predictions. All deorbit engine heaters operated normally, raising the engine module temperature above minimum design requirements. The equipment bus current trace verified successful operation of the terminal descent engine heaters and terminal engine pyro valve 2 heater. There were no thermal subsystem anomalies during this period.

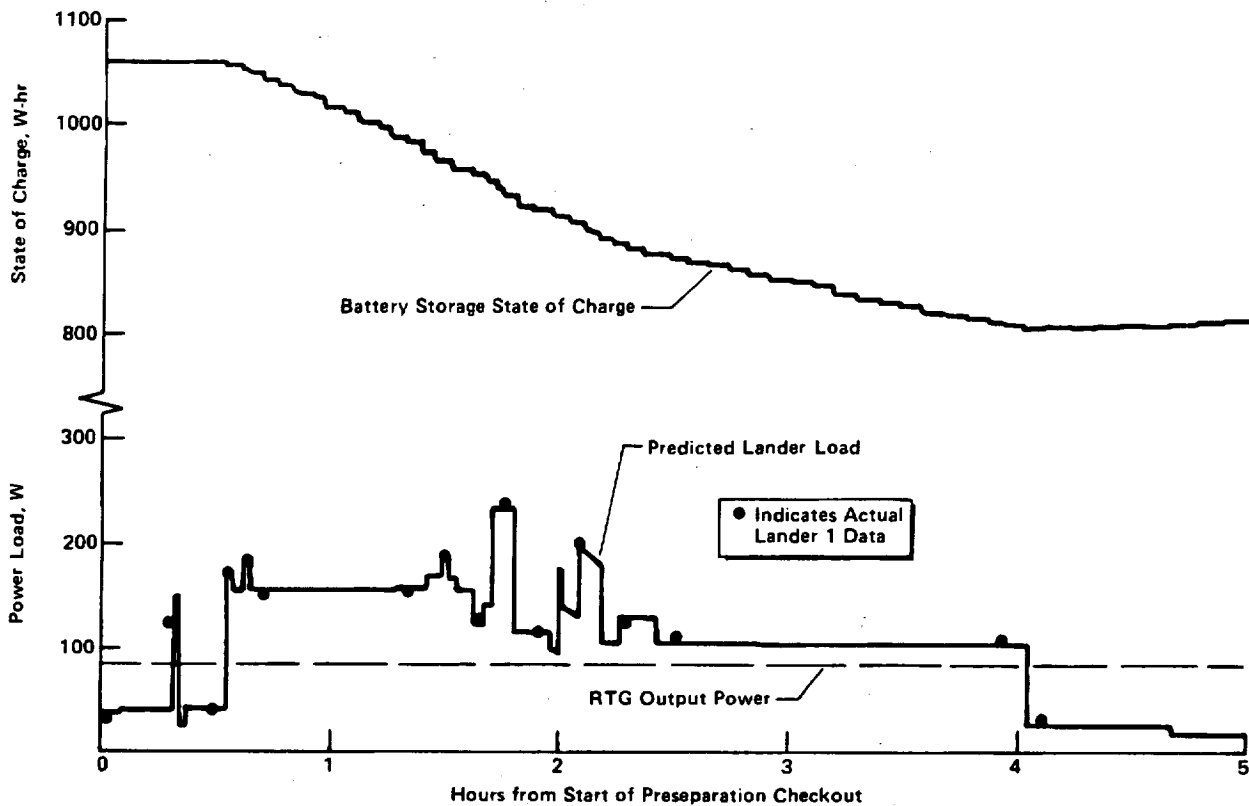

Figure IV-4 Lander Loads during Preseparation Checkout

B. PRESEPARATION BATTERY CHARGING

During the preseparation checkout, approximately 250 W-hr of electrical energy were taken out of the four Lander batteries. Following preseparation checkout, battery charging activities were performed to replace this energy before separation. One battery at a time was sequentially charged for a 1-hr period. The charge sequence was battery A, C, B, D, A, C, B, D. The batteries were charged from the Lander PCDA battery charger, which supplied 1.5 amp for this period. To preclude overcharging the batteries during this final charge, the redundant PCDA charge control logics were enabled, which stopped the charge based on the predetermined voltage/temperature relationship shown in Figure III-7. Battery temperatures during charging were between 68.5°F and 81.4°F and below the predicted maximum of 84°F. A typical battery voltage profile during charge is shown in Figure IV-5. Actual charge times are in Table IV-2.

Lander 1 batteries were fully charged as indicated by four PCDA logic cutoffs. Lander 2 batteries were estimated to be about 17 W-hr less than

Table IV-2 Actual Battery Charge Times (hr:min)

Battery	Lander 1	Charge Stopped by PCDA Logic	Lander 2	Charge Stopped by PCDA Logic
A	1:47	Yes	1:53	Yes
B	1:47	Yes	1:41	Yes
C	1:50	Yes	2:0	No
D	1:59	Yes	2:0	No

full charge (1060 W-hr), which was well within the allowable margin of 132 W-hr.

Having successfully completed battery charging, the power subsystem was then put into a mode where excess RTG power was shunted around the shunt regulator directly into a load bank located external to the Lander body to minimize heat input into the Lander. The power subsystem stayed in this mode, except for a 62-min period during the S - 9.5-hr update, until the S - 3.5-hr update. At this time, the power subsystem was returned to its normal shunt regulator operation where it remained during descent and landed operations.

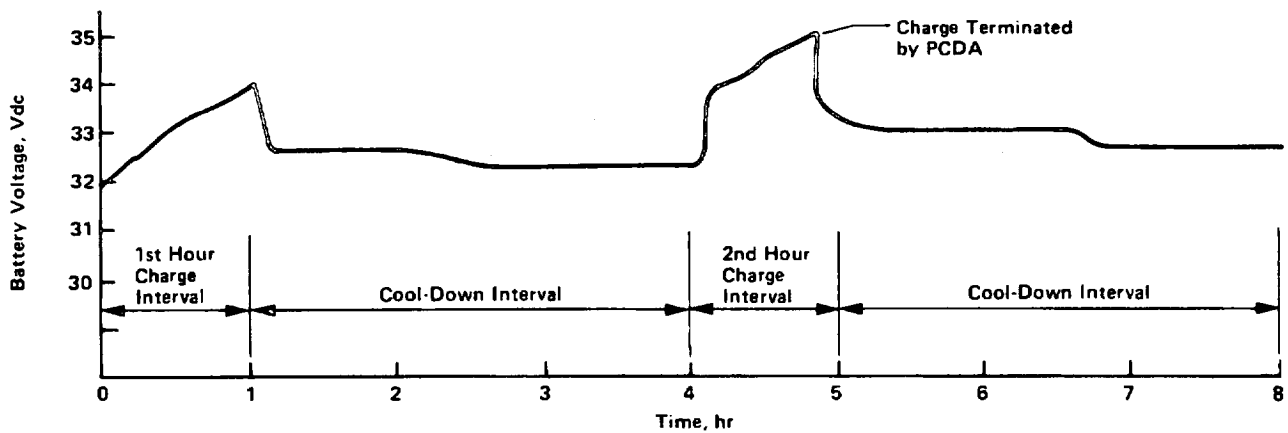

Figure IV-5 Battery Voltage during Preseparation Charging

C. SEPARATION - 9.5 HOUR UPDATE

As mentioned previously, the primary purpose of this update was to change any of the GCSC preprogrammed data base values or component selections as a result of knowledge gained from the preseparation checkout. On Lander 1, the only change required was an adjustment to selected XRFS proportional counter tube gain voltage settings due to observed gain drifts of 10 to 15%. This adjustment would increase the argon analysis accuracy to be performed on sol 0. On Lander 2, two changes were required: one for the GCSC to ignore TDLR channel 2 data during descent due to the false locks observed during preseparation checkout, and the other to not turn on the biology lamp for the first landed pyrolytic release analysis. The biology change was not a result of preseparation checkout analysis, but an on-going thermal analysis that revealed the biology would reach too high a temperature during the first pyrolytic release experiment if the Martian environment approached the design "hot case." Consequently, a decision was made to leave the lamp off until later in the mission.

The GCSC had been counting down the preseparation sequence since the S - 30-hr preseparation checkout command and initiated the update mode at S - 9.5 hr by turning on the command detectors and commanding the DAPU to format 5. This format gave an uplink segment verification capability. The command file consisted of the update elements and an "end of message" segment, which forced a memory read out. The GCSC had been programmed to stay in this update mode for 2.5 hr to allow for a worse-case uplink duration. To keep the Lander internal temperatures down, a command segment was sent after the memory read out

was received to return the DAPU to standby, return to the shunt regulator bypass mode, and turn the command detectors off. This resulted in an hour-long sequence and was accomplished without anomalies on both Landers.

D. SEPARATION - 3.5 HOURS TO SEPARATION

At S - 3.5 hr, the GCSC commanded the Lander to a command update mode, continuing its preprogrammed countdown to separation that had begun at S - 30 hr. The command detectors were turned on, telemetry changed from a low data rate cruise mode to the 2 kbps format 5 mode, and the GCSC awaited any update commands from the ground. Also, the power system was commanded to discontinue the shunt regulator bypass mode. Before this time, due to the 30-min roundtrip communications time, the flight team checked Lander status, then transmitted a command file so that it would arrive at the Lander 2 min after entering the update mode. No further GCSC updates were required on either Lander, so only a test command was transmitted as an end-to-end test of the ground and spacecraft command systems in preparation for the "Separation Go" command. The test command for both Landers consisted of two segments, one to establish a set of memory readout parameters and the other to force the memory readout for command capability verification. This activity was accomplished successfully on both Landers. Lander status continued to be monitored while the GCSC counted down to the next major event—the separation command from the Orbiter. This command was not one for actual separation, but was a command loaded in the Orbiter to be sent at exactly S - 2 hr 47 min to provide the capability to

adjust the actual time of separation by a small amount if new data relative to the descent trajectory indicated a need. This also allowed the Orbiter and Lander to be synchronized to the same exact separation time. The descent design was verified to be so nominal that no separation time update was required for either mission and the time that had been established at S - 62 hr was used. At this time, the Orbiter also enabled a Lander separation inhibit routine that would safe the Lander and prevent separation if it detected certain selected Orbiter anomalies. The GCSC had been programmed to look for the separation command and resynchronize its countdown sequence to exactly S - 2 hr 47 min.

Upon receiving this command, the GCSC initiated format 3 to provide better engineering subsystem status, then 1 min later commanded IRU thermal power on to start its required warmup period. The warmup was started on the Lander entry bus due to an initial high power turn-on transient, then switched to the BPA to minimize use of the Lander batteries. IRU power consumption was checked at this time, with a ground commanded abort capability if not within prescribed limits. This was not necessary because both Landers met expected values. At S - 2 hr 43 min, the Orbiter transferred from sun/Canopus attitude control to IRU roll inertial control. Lander status was continually monitored. Then, at S - 1 hr 45 min, each telemetry measurement was checked against a predefined set of narrow limit separation go/no-go criteria. Both Landers were well within predicted limits. At S - 1 hr 28 min, IRU operate power was commanded on and the telemetry mode switched to format 2P to provide visibility of IRU health before committing to separation. Again, IRU power consumption, gyro spin up time, and the gyro and accelerometer pulse counts were checked against a predetermined set of criteria limits. Additional telemetry measurements provided by this telemetry mode were also verified to be within limits. Both Landers passed these final checks within expected performance and a "Go for Separation" report was given to the Viking Mission Director at S - 1 hr 16 min. After the IRU check, the GCSC returned the telemetry mode to format 3. After all elements of the Flight Team were polled, Mission Director approval for separation was obtained and the "Separation Go" command was transmitted at S - 1 hr 4 min. This command which had to reach the spacecraft before S -15 min (spacecraft time) consisted of two segments (for redundancy of acceptance) which would set a

flag in the GCSC software to enable separation. This was to be the last command sent to both Landers until after landing. From this point on, the Landers were on their own to continue autonomously the countdown to separation and eventual descent to landing.

At S - 1 hr, the Lander IRU was switched from the BPA to the internal entry bus. At S - 14 min 34 sec, command detectors were turned off, the RCS VDA powered on, and both Lander LPCAs powered to charge their capacitor banks in preparation for the first pyrotechnic event—separation. In another 30 sec, all RCS engine valves were commanded on (with no propellant flow), beginning a 13.5-min warmup period to avoid the freezing of the propellants in the solenoid valves prior to use. At this time the Lander equipment bus delivered almost 500 watts to the various loads powered. Two minutes before separation, the RCE transmitter was turned on in the 1-watt mode, format 2 initiated, and the Orbiter switched to the feed-through mode thereby supplying Earth with telemetry over the Lander-to-Orbiter relay link. Previous to this time, telemetry had been routed via hardline from the Lander to the Orbiter. When the switch was made, there was no noticeable degradation in data quality from either spacecraft. Thirty two seconds prior to separation, all RCS engine valves were commanded off, thermal control heaters that were powered from the BPA were transferred to internal power, and the PCDA undervoltage sensor disabled (it was locked out of this automatic safing until after landing). Three seconds later the GCSC made four very important tests to verify: capability to read the R6 tested discrete register, no error interrupts (ERI) had occurred, the IRU is on the entry bus, and the "Separation Go" flag has been set. Failure of any one of these tests would have aborted separation, causing the GCSC to safe the Lander and go into an update mode awaiting further direction from the ground. At S - 11 sec, the GCSC started separation initialization, which involved GCSC and IRU protection circuits being bypassed to preclude shutting down these components during the critical descent. Ten seconds prior to separation, the bioshield base staging connector, through which all electrical signals and power from the Orbiter and BPA had passed to the Lander, was electrically disconnected. Finally, at S - 0, the GCSC sent the commands to the redundant LPCAs to fire the pyrotechnic explosive bolts resulting in Lander/Orbiter separation. This whole series of events were executed flawlessly on both Lander 1 and 2.

ORIGINAL PAGE IS
OF POOR QUALITY

V. SEPARATION THROUGH LANDING PHASE

- A. Guidance and Control Subsystem
- B. Communications Subsystem
- C. Telemetry Subsystem
- D. Power Subsystem
- E. Propulsion Subsystem
- F. Thermal Subsystem
- G. Pyrotechnics Subsystem
- H. Structures and Mechanisms Subsystem
- I. Science Subsystem

This large rock (named "Big Joe" by the flight team) is about 7 feet long, 3 feet high, and 26 feet from Lander 1. The horizon is about 1 mile away.

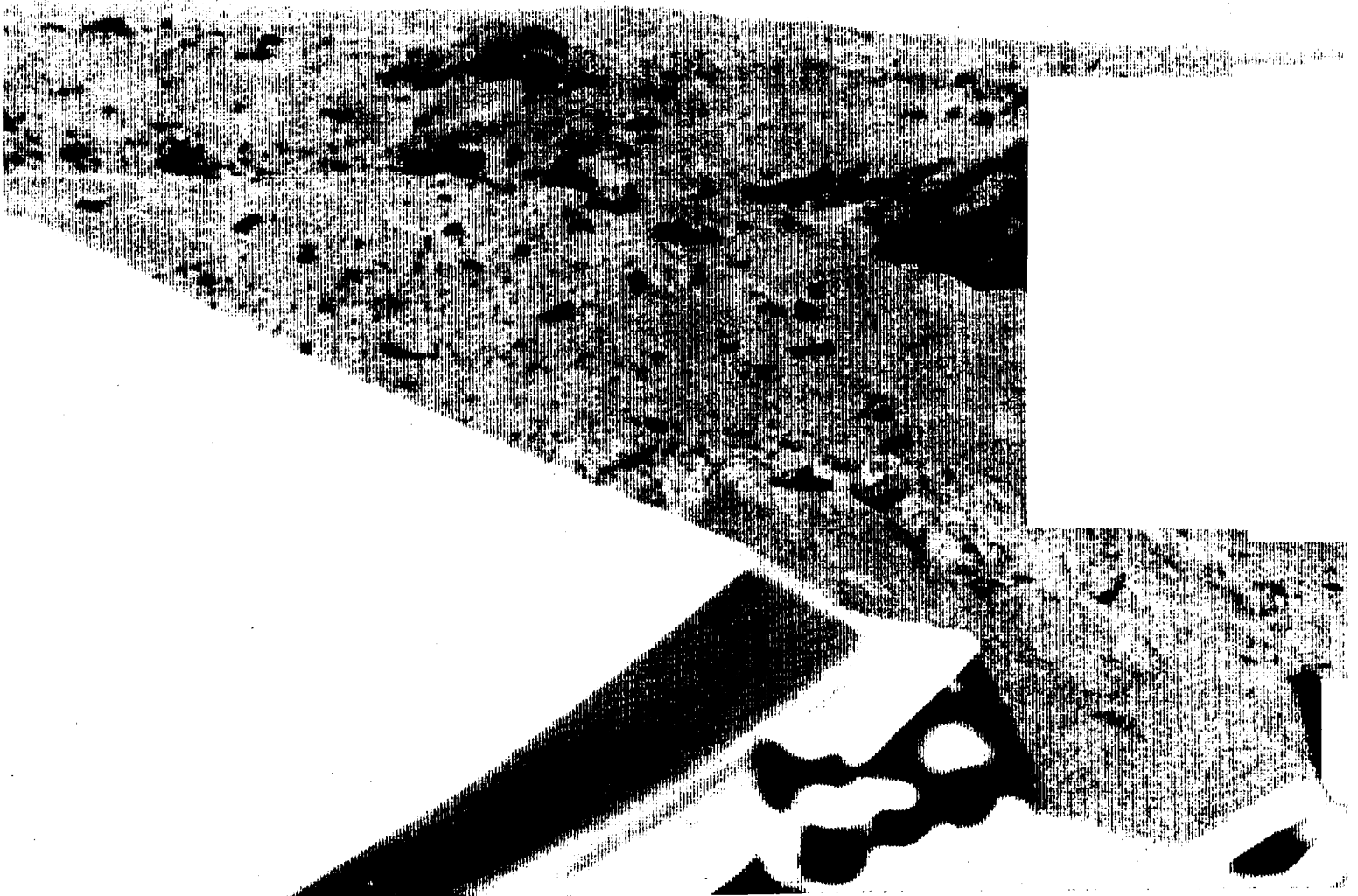

V. SEPARATION THROUGH LANDING PHASE

During this phase, the Lander engineering hardware was called upon to perform in a very exacting manner, in some cases for the first and last time as an element of the Viking Lander. The entry science was initiated and performed the entry investigations, and shortly after landing, camera 2 was activated and the landed science investigations were begun. This chapter describes Lander subsystem performance during this most critical mission phase. This performance was extracted from real-time and stored data relayed to Earth from Lander 1, and data received from Lander 2 after its landing. (Chapter II of this report describes the Orbiter anomaly that delayed the Lander 2 data.) A more complete analysis of the entry data is contained in TN-3770218, *Entry Data Analysis for Viking Landers 1 and 2*. General system performance data are described in the guidance and control section following, along with specific subsystem data.

A. GUIDANCE AND CONTROL SUBSYSTEM

During this phase, the guidance and control subsystem not only controlled and sequenced all Lander operations, it also performed the navigation, guidance, and steering functions necessary for separation through landing.

1. Deorbit Burn

The first major event was deorbit burn. The Lander 1 burn was 1759.8 sec and Lander 2 was 1757.1 sec as compared with a required burn time of 1757 sec for both. The differences of 2.8 and 0.1 sec were well within the acceptable difference of 6 sec. During deorbit burn, attitudes were within the predicted maximums, but attitude rates exceeded predictions as shown in Table V-1. No adverse effects were noted from the departure from nominal rates. Simulations have shown that

Table V-1 Observed Attitudes and Rates during Deorbit Burn

Item	Observed Maximum		Predicted Maximum
	Lander 1	Lander 2	
Roll Rate, deg/sec	0.41	0.39	1.69
Pitch Rate, deg/sec	-1.81	-2.08	-0.85
Yaw Rate, deg/sec	-1.09	-2.07	0.85
Roll Attitude, deg	0.25	0.26	±0.25
Pitch Attitude, deg	0.34	0.31	±0.35
Yaw Attitude, deg	0.35	0.33	±0.35

reasonable combinations of cg offsets, engine thrust mismatch, and thrust vector misalignments can duplicate rates in the above range.

2. Deorbit Coast

After the deorbit burn, the Lander was re-oriented to collect high altitude science data. In addition, a 180-deg roll maneuver was accomplished to equalize sun-induced temperatures on the base cover. All attitudes remained within the planned course limit cycles of ±5 deg. Again the attitude rates exceeded nominal predictions with no detrimental effects. The factors given above apply in this case also.

The net result of all accumulated errors at the end of coast is shown in Table V-2. The targeted conditions were those desired and entered in the GCSCs prior to separation. It can be observed from data in Table V-2 that the reconstructed estimates of the critical conditions at entry are excellent when compared to the targeted values.

Table V-2 Estimated Conditions at Entry

Item	Lander 1		Lander 2	
	Targeted	Reconstructed	Targeted	Reconstructed
Inertial Velocity, ft/sec	15,124.7	15,124.3	15,138.8	15,131.7
Inertial Flight Path Angle, deg	-16.90	-16.99	-17.01	-17.08
Aerographic Latitude, deg N	12.78	12.70	36.89	36.78
Aerographic Longitude, deg W	62.00	62.15	243.04	243.13

Based upon a preprogrammed time from deorbit burn and prior to predicted entry, the descent capsules were oriented for entry. These maneuvers were performed as planned.

3. Entry to Parachute Deployment

Entry had been arbitrarily defined as 800,000 ft, although the atmosphere is apparent only from about 300,000 ft. However, the altitude estimates used in the navigation software were markedly improved because the radar altimeters were turned on at entry. This phase is mechanized as follows: RA

2 is turned on at 800,000 ft as derived by the inertial navigator. If there is no lock in 30 sec, RA 2 is turned off and RA 1 turned on for 30 sec. This sequential operation continues until lock is obtained. These radar data are not used until about 260,000 ft. For both Landers, RA 2 locked on the planet on the first sweep after turn on. This lock is expected to be ambiguous—the signal return from the planet reaches the radar after the next outgoing pulse is transmitted. For the Landers, range is ambiguous beyond about 700,000 ft. As the Lander approaches 700,000 ft, an unlock is forced. Relock cannot occur until the return, which is now unambiguous, indicates an altitude of approximately 450,000 feet or less. For both Landers, RA 2 was on when the target came within this range gate, lock then occurred again on the next sweep, and no unanticipated loss of lock occurred. RA 2 was used on both vehicles until touchdown. The performance of the system during this high-altitude region of entry is shown in Table V-3. The initial error is the difference between inertial altitude estimate and radar altitude measurement at the time these data are first used to update inertial estimates. Convergence time is the time required to reduce the difference to about 2% of the initial error. The data were first used in navigation at about 258,600 ft.

Table V-3 Entry High Altitude Performance

Item	Lander 1	Lander 2
Ambiguous Lock Altitude, ft	779,400	792,300
Ambiguous Unlock Altitude, ft	704,900	728,000
Unambiguous Lock Altitude, ft	432,200	432,700
Initial Error, ft	11,000	-300
Convergence Time, sec	<4	<4

The aerodynamic portion of the entry phase began with sensing of 0.05 g deceleration and ends with parachute deployment. A programmed pitch maneuver was performed just before this time to point the descent capsule axial centerline in a direction so that when aerodynamic flow occurred, the angle of attack would be at -11.1 deg. Upon sensing 0.05 g, the control mode was switched from full attitude control in pitch and yaw to rate damping only. Attitude hold in roll was retained to keep the RA antenna pointed toward the planet. Table V-4 summarizes the results.

Lift was used to give the high drag forces sufficient time to dissipate entry velocity. A forward center of gravity position was used as a passive means to perform this function. The net result was

Table V-4 Maximum Observed Attitude Rates during Aerodynamic Entry

Item	Lander 1	Lander 2	Desired
Roll Rate, deg/sec	1.4	-1.4	<2
Pitch Rate, deg/sec	-1.3	1.4	<2
Yaw Rate, deg/sec	1.6	1.7	<2

a temporary reduction in the magnitude of the flight path angle followed by a sharp increase near the point of parachute deployment. The results were dramatic. The descent capsules flew almost horizontally over 100 miles on the approach to the landing site. Table V-5 gives the key data at the time of parachute deployment. These results are entirely satisfactory. Both vehicles trimmed at about 2 deg higher negative angles of attack than expected and thus both displayed a higher lift-to-drag ratio, which was beneficial. Side slip angles of less than 1 deg were observed.

Table V-5 Conditions Observed at Parachute Deployment

Item	Lander 1	Lander 2	Design Limit
Radar Altitude, ft	19,273	19,224	19,000 ± 550
Relative Velocity, ft/sec	763	778	NA*
Flight Path Angle, deg	-53.4	-50.8	NA
Mach Number	1.1	1.1	<2.1
Dynamic Pressure, lb/ft ²	6.7	7.9	<8.6

*NA = Not applicable.

Entry loads and heating results are shown in Table V-6. Only the base cover heating results were significant departures from expected values. No detrimental effects were observed.

Table V-6 Entry Loads and Heating Results

Item	Lander 1	Lander 2	Design Limit
Aeroshell			
Heating Rate, Btu/ft ² /sec	20.9	21.4	25.6
Total Heat, Btu/ft ²	1035	1046	1240
Dynamic Pressure, lb/ft ²	98	96	144
Base Cover			
Heating Rate, Btu/ft ² /sec	Sensor Failed	0.9	0.5
Total Heat, Btu/ft ²	Sensor Failed	43.9	24.8
Collapse Pressure, mb	0.1	Sensor Failed	1.44
Burst Pressure, mb	0.14	Sensor Failed	6.76

4. Parachute Phase

As shown in Table V-5, the conditions at parachute deployment were well within the desired conditions. The parachute was pyrotechnically deployed when an altitude of 19,300 ft was computed. Shroud line extension was completed in about 1 sec and inflation occurred less than 2 sec after mortar fire. The peak loads imparted to the Lander by the parachute were about 11,000 lb, and well within the design limit of 17,500 lb. The attitude rates were 60 deg/sec on Lander 1 and 51 deg/sec on Lander 2. These may be compared to the gyro rate-torquing capability of 100 deg/sec. Parachute drag coefficients of between 0.65 and 0.70 were slightly higher than expected. Very little wind was encountered during parachute operations. Data indicated wind velocities of about 85 ft/sec for Lander 1 and 35 ft/sec for Lander 2 compared to a design capability of over 250 ft/sec.

The aeroshell was released pyrotechnically 7 sec after parachute deployment. The RA was inhibited temporarily to permit transfer of the signal path from the aeroshell antenna to an antenna located on the Lander body. Three seconds after aeroshell separation, the RA was re-enabled and the velocity radar (TDLR) turned on. Use of both altitude and velocity data by the navigator began at this time. On both Landers, TDLR channel 2 detected the presence of the aeroshell as it fell away. According to plan, drop-lock was forced in this channel momentarily, and upon reacquiring lock, the planet's motion was sensed. No further false targets were observed. It is interesting to note that although velocity channel 2 on Lander 2 had been locked out of use in the GCSC software as a result of pre-separation checkout results, this channel functioned nominally.

Table V-7 shows the initial errors between the navigator estimates and the measurements by both the RA and TDLR. These errors quickly converged in less than 3 sec and were quite low by the time altitude and velocity data were required for terminal descent.

Table V-7 Initial Errors after Aeroshell Separation

Item	Lander 1	Lander 2
Radar Altitude, ft	14,924	14,968
Altitude Error, ft	-101	-56
Velocity Error, ft/sec	102	143

Landing legs were deployed and locked in place in this phase and a roll maneuver was accomplished to align leg 1 with a desired azimuth. This roll maneuver was accomplished to provide proper lighting angles for imaging after landing. A swivel in the parachute suspension provided roll torque isolation.

The final conditions on the parachute at the time of terminal descent engine ignition are shown in Table V-8. These conditions were quite satisfactory. The total elapsed time between mortar fire and engine ignition was 62 sec for Lander 1 and 64 sec for Lander 2, a comparison which shows the similarity of the two flights.

Table V-8 Reconstructed Conditions, End of Parachute Phase

Item	Lander 1	Lander 2	Desired
Altitude, ft	4787	4718	4798 ± 300
Relative Velocity, ft/sec	175	167	< 360
Flight Path Angle, deg	-70	-80	> -45

5. Terminal Descent

The final phase began with terminal engine ignition while the Landers were still attached to their parachutes. This event was initiated after 4800 ft was computed. Following a 2-sec engine warmup period, the parachute and base cover were separated and the Lander accelerated toward the planet under idle-thrust conditions. At this time, the steering loops were closed and the terminal guidance phase began. During this fall toward the planet, a maneuver called tipup was performed to place the thrust vector opposite the total velocity vector so the lateral velocity may be removed in a gravity turn trajectory prior to touchdown. After this maneuver, the Landers descended essentially vertically. Upon reaching the altitude of the programmed altitude-velocity contour, high thrust was commanded to allow the Landers to match the planned contour. From the point of ignition to the start of high thrust, about 12 sec elapsed. Both Landers maintained high thrust for about 23 sec, averaging about 50% thrust level. The conditions during the very critical tipup maneuver are shown in Table V-9.

From about 135 ft above the surface, RA data were ignored as planned and inertial navigation was used to touchdown. A constant velocity descent

was planned to begin at 55 ft and both Landers entered this phase about 8 ft high. This suggests a systematic error somewhere in the system, but only resulted in this phase taking about 1 sec longer than planned.

Table V-9 Maximum Observed Conditions at the Tip Up Maneuver

Item	Lander 1	Lander 2	Design Limit
Pitch Attitude, deg	6.3	0	±60
Yaw Attitude, deg	12.5	-5.3	±60
Pitch Rate, deg/sec	11.5	0	±30
Yaw Rate, deg/sec	13.4	7.9	±30
Completion Time, sec	1.0	0.3	3

Attitude perturbations and rates were almost zero during the entire terminal descent phase and touchdown occurred with only a minor incident. During the last 0.5 sec, both Landers indicated a momentary increase in throttle settings for one or more engines. This has been attributed to the sensing by the velocity radar of dust blown up from the planet in the last few feet of descent. There was no effect on the Landers. The touchdown was sensed by contact of the landing legs with the surface, resulting in a signal being sent by the GCSC that pyrotechnically closed a propellant valve and shut down the engines. Table V-10 shows the dynamic conditions at touchdown.

Table V-11 is a tabulation of the final positions of the Landers after they had come to rest on Mars.

Table V-10 Maximum Dynamic Conditions at Touchdown

Item	Lander 1	Lander 2	Design Limit
Pitch Attitude, deg	0.6	-1.2	±5
Yaw Attitude, deg	0.3	-2.2	±5
Pitch Rate, deg/sec	-0.9	-1.2	±7
Yaw Rate, deg/sec	-0.4	1.9	±7
Axial Velocity, ft/sec	8.2	8.1	8 ± 3
Lateral Velocity, ft/sec	-0.5	-0.6	0 ± 3

Table V-11 Final Landing Positions

Item	Lander 1	Lander 2
Elevation from Mean Surface Level, ft	-4600	-8860
Aerographic Latitude, deg N	22.46	47.96
Aerographic Longitude, deg W	48.01	225.77
Tilt Angle, deg	3.0	8.2
Slope Azimuth (E of N), deg	285.2	320.7
Azimuth of Leg 1, deg (E of N) (Targeted Azimuth)	321.6 (320)	209.1 (210)
Total Landing Error, mi	18.3	3.7

6. Initial Landed Operations

Immediately following landing, the GCSC initiated deployment of the high-gain antenna, meteorology boom, and biology processor and distribution assembly cover; initiated camera 2 activities; and generally controlled the Lander activities required for the landed mission. The GCSC also calculated landed orientation and prepared a software table for high-gain antenna pointing. All guidance and control components except for the GCSC were then powered down for the remainder of the mission. Lander engineering data, a GCSC memory readout, an image of footpad 3, and a panorama of the landing site were relayed to the Orbiter for storage on the Orbiter and subsequent transmission to Earth. This initial landed relay link lasted for 15 minutes.

B. COMMUNICATIONS SUBSYSTEM

The voice of the Lander following separation was the UHF link to the Orbiter with real-time feedthrough of data to Earth via the Orbiter S-band telemetry. A real-time performance measure of the UHF link was the instrumented receiver signal level (RSL) at the Orbiter receiver. These data are shown in Figures V-1 and V-2 for Lander 1. The Lander 2 performance was almost identical.

The Lander transmitter was sequenced "on" in the 1-watt power mode 2 min before separation, transmitting Lander engineering data to the Orbiter at a rate of 4 kbps. The RSL measurement was in saturation for the first 10 min following separation due to the close proximity of the two vehicles. The communication range increased rapidly during deorbit burn. The RSL dropped below the saturation level of -50 dBm and exhibited near nominal predicted performance throughout the deorbit burn phase.

During the following 2 hr the UHF transmitter was sequenced on in the 1-watt power mode for 71 sec approximately every 6.5 min for transmission of entry science and engineering data to the Orbiter for relay to Earth at a rate of 4 kbps. The communication link geometry remained as predicted during this phase with the observed decrease in the RSL being indicative of the expected increase in communication range.

The UHF transmitter was sequenced "on" in the 10-watt power mode 40 min before entry (800,000 ft). The increased power level was pre-

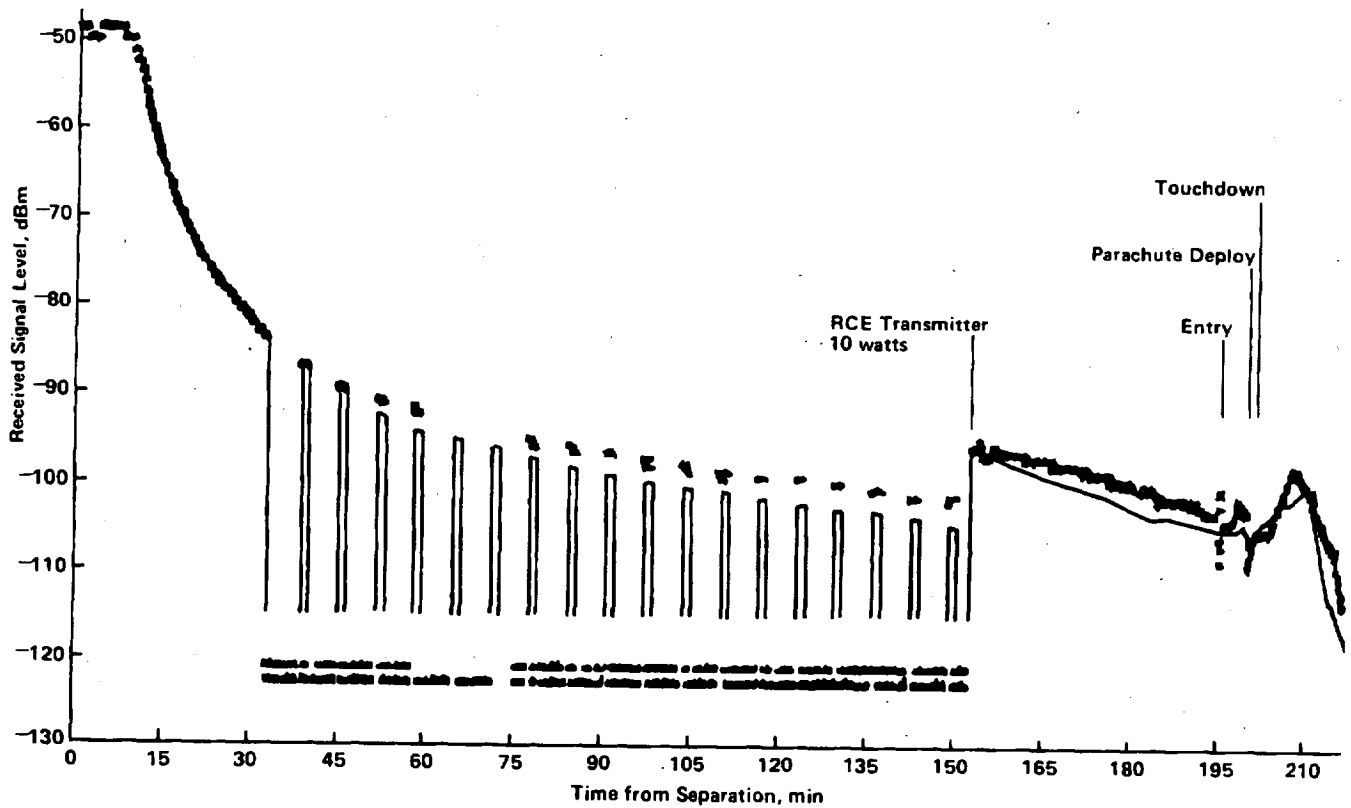

Figure V-1 Lander 1 Relay Link Performance from Separation through Landing

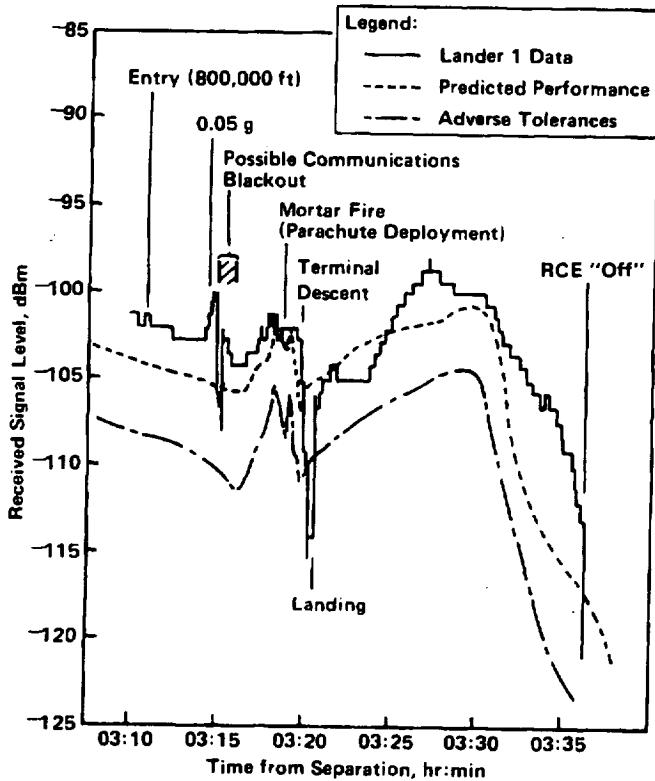

Figure V-2 Lander 1 Relay Link Performance from Entry through Landing

programmed before separation to compensate for the anticipated Lander dynamics during entry and physical Lander configuration changes that were to occur during the parachute and terminal descent phases.

The RSL measurement became the sole indicator of Lander 2's progress toward the surface of Mars when the real-time feedthrough capability containing all Lander science and engineering data was interrupted shortly after separation. These data were not lost because they were being recorded on the Orbiter and Lander for playback to Earth at a later time. The Orbiter low-rate data link containing the RSL measurement was reacquired while the Lander was in the deorbit coast phase just before the seventh RPA sequence. A quick assessment of the RSL indicated the Lander performance was near nominal. The subsequent 5 dB increase in the RSL verified that the Lander transmitter had switched to the 10-watt power mode as scheduled. The increase in RSL before entry was indicative of the Lander entry orientation maneuver, although this maneuver was not modeled in the predictions. The RSL profile became quite dynamic following entry due to changes in the Lander altitude, configuration, and the entry

environment. However, the RSL showed no indication of a Lander malfunction throughout the critical entry phase. The question of whether or not link degradation had occurred due to plasma in the wake created as the Lander passed through maximum Q cannot be conclusively answered. A 6.5 dB reduction in the RSL was observed during Lander 1 entry at the expected time of possible communication blackout. This drop in RSL was not observed during Lander 2 entry but may have been missed due to the relatively slow RSL sample rates.

Eleven seconds after landing, the Lander data rate was switched to 16 kbps. This event was verified through monitoring of the Orbiter UHF receiver telemetry and provided the only real-time verification that Lander 2 had successfully landed. The initial landed link was completed as expected, which verified deployment of Lander hardware and provided imaging and memory readout data for verification of the landing site latitude and Lander orientation on the surface of Mars. The relay radio equipment on both Lander 1 and 2 performed exactly as expected throughout the separation to landing mission phase.

C. TELEMETRY SUBSYSTEM

The three telemetry formats used from separation to landing were formats 2, 2A, and 3. The performance of the Landers throughout this period was monitored and entry science data acquired by transmitting these data formats in a preprogrammed sequence illustrated in Figure V-3. Format 2 was designed so that if the link from Lander to Orbiter was interrupted for as long as 1 min or less there would be no loss of data. This was accomplished by transmitting all of the data twice—first in real time, and again 1 minute later, interleaved with the then real-time data. The DSM was used as

a circulating buffer 120,000 bits long (the amount of new data collected in 1 min). New (real time) data continually replaced the oldest data in the buffer as the old data were read out and interleaved bit-by-bit with the transmitted real-time data.

Interruptions in the link were considered possible just after separation because of the strong Lander signal and the short distance to the Orbiter relay receiver. Again, in the period shortly after sensing 0.05 g deceleration, it was expected that the signal would be attenuated by ionization of the atmosphere sufficiently to interrupt the link for up to 45 sec. During both of these periods, format 2 was used to avoid loss of data. These predictions appear to have been conservative; no interruptions were observed on either Lander.

At 32 min 38 sec after separation, a sequence of 18 bursts of format 2A at about 6.5-min intervals was begun. Each burst of data was 71 sec long. After the 18th burst, format 2A was turned on continuously until 0.05 g deceleration was sensed. This format was designed to collect entry science data. Of the total data allocation, 20% was for the RPA and 20% for the UAMS. Guidance data were allocated 30%, and other engineering data the remaining 30%.

Format 2 was initiated at 0.05 g and continued to 6 sec after parachute deployment. At this point, format 3 began and continued until 11 sec after touchdown. In each of these formats, 60% of the data allocation is to guidance and 40% to other engineering performance data.

At about 20 minutes before the predicted touchdown, the Lander tape recorder was turned on and recorded all transmitted data through touchdown. Had the Lander-to-Orbiter relay link

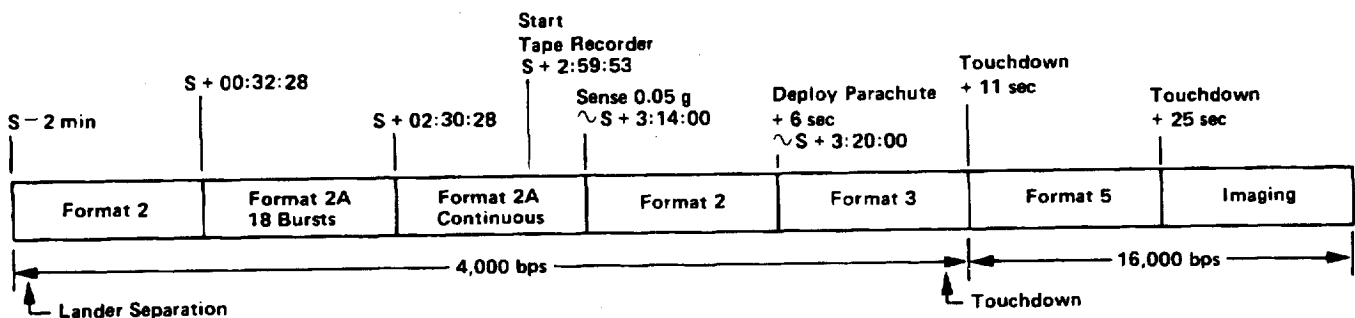

Figure V-3 Telemetry Data Sequence from Separation through Touchdown

failed or been badly degraded during this entry and descent phase, the data would have been recovered by tape recorder playback at some time after landing. The relay link was excellent and this backup entry data provision was not required. However, these data were played back later during the landed mission and indicated nominal tape recorder performance during entry.

The telemetry subsystem flawlessly executed its planned operations for both Landers during this phase. As previously noted, Lander 2 separation to landing data were not received in real time because

of an Orbiter orientation problem. These data were stored on the Orbiter tape recorder and successfully played back a few hours later.

D. POWER SUBSYSTEM

The power subsystem supported the Landers as anticipated from separation to their successful landings on Mars. Figure V-4 shows the predicted Lander power consumption and the minimum predicted battery state of charge versus time from separation. A few data points from Lander 1 have

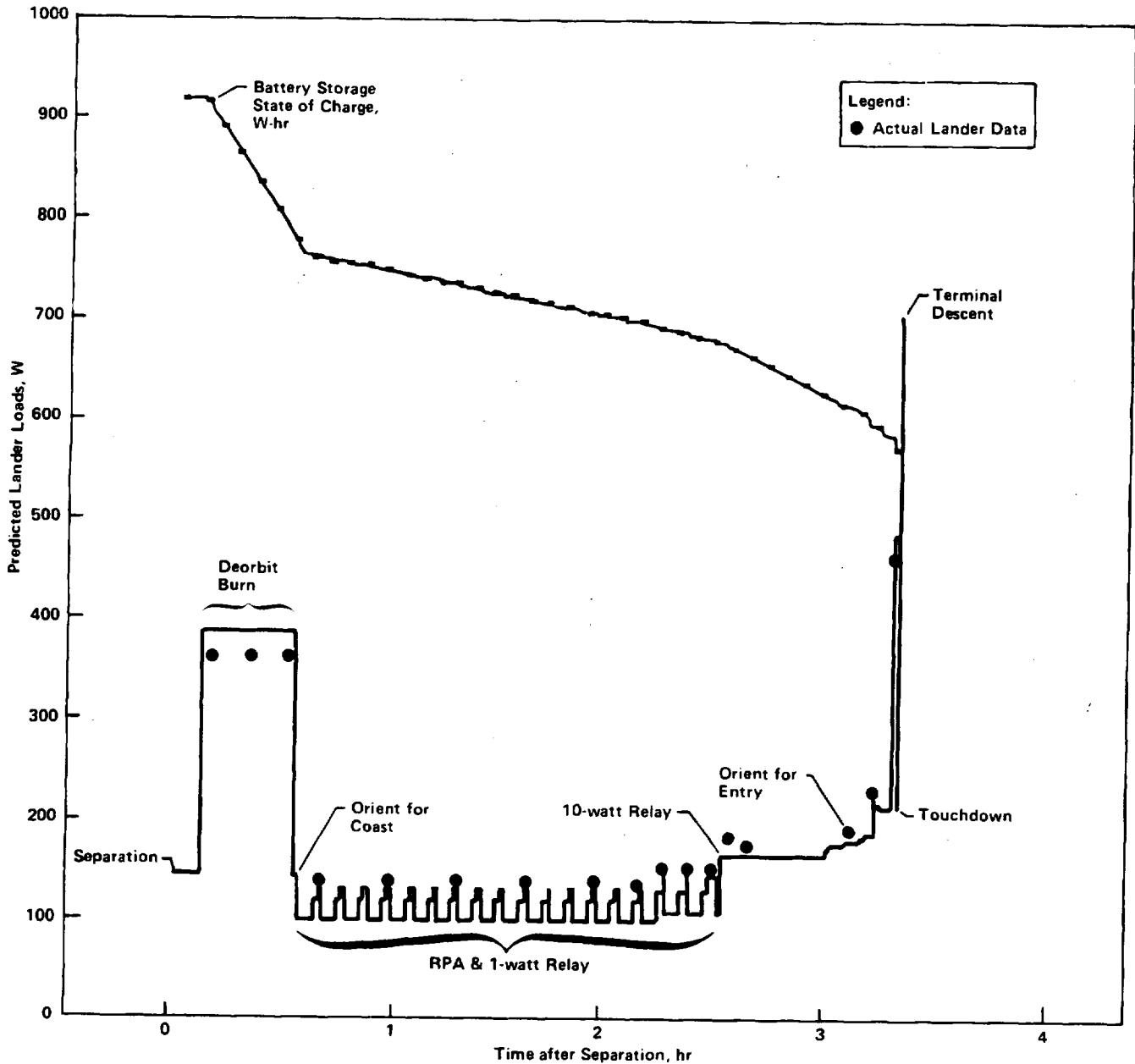

Figure V-4 Separation through Landing Power Profile

been included to show how closely the Lander performed to the nominal mission load profile. Lander 2 load profile was within 5 watts of the Lander 1 data. The actual battery state of charge (SOC) was higher than that predicted, indicating that less energy was used than predicted.

After touchdown the batteries were recharged 2 to 4 hr earlier than the 24 hr predicted. At an estimated 25 W-hr charge rate, this indicated that

the energy used during descent was 100 W-hr less than predicted for Lander 1 and 50 W-hr less for Lander 2.

The power subsystem performance, such as RTG power output and PCDA converter/charger efficiencies, was as expected and is discussed in Section D of Chapter VI of this report. In general the performance was nominal with no surprises. Table V-12 shows the average power consumption

Table V-12 Viking Lander Loads

Item	Average Load, watts	Item	Average Load, watts
POWER/PYROTECHNIC CONTROL		Valve Drive Amplifiers	
Power Condition and Distribution Assembly		RCS/Terminal Roll	3.0-33.0
Standby	3.4	Terminal Engine Throttle Valves	
Operating	4.8-10.8	Electronics	28.0
Lander Pyrotechnic Control		THERMAL CONTROL	
Assembly 1 or 2	1.8	RCS/Deorbit Engine Heaters	7.8
COMMUNICATIONS		Terminal Descent Engine Heaters	37.4
UHF Transmitter		Feed Line Heaters	4.4
1 W Mode	23.5	RCS/Deorbit Tank Heaters	8.0
10 W Mode	43.0	Backup RCS/Deorbit Heaters	6.0
30 W Mode	118	Terminal Engine Tank Heaters	8.0
S-Band Antenna Controller	2.0	Terminal Engine Pyro Valve No. 2 Heaters	1.5
S-Band Transponder		RCS Pylon Heaters 2 and 3	14.4
S-Band Modulation Exciter (1 or 2)	4.2	RCS Pylon Heaters 1 and 4	3.6
Command Receiver (1 or 2)	3.1	PROPULSION	
S-Band TWTA and Power Supply (1 or 2)	90.0	Reaction Control System	292
Command Detector/Decoder (1 or 2)	2.5	Terminal Propulsion	220
TELEMETRY		Terminal Roll Engines	29
Data Acquisition and Processor Unit		SCIENCE	
Standby	2.0	Surface Sampler Subsystem (1 or 2)	
Operating	9.1-9.7	Standby	14.0
Tape Recorder		Soil Acquisition	40.0
Standby	5.8	Imagery	
Operating	7.9-9.9	Heater	2.0
Data Storage Memory		Operating	16.2-25.4
Standby	0.1	Standby	16.2
Operating	10.2	Camera Duster Control	5.0
Aeroshell Pressure Transducer	0.6	Seismometer	3.3
Base Cover Pressure Transducer	0.2	GCMS	
GUIDANCE AND CONTROL		GCMS Ion Pump	1.0
Guidance, Control, and Sequencing Computer (GCSC)		Atmospheric Analysis	22-35
Sleep	3.9	Organic Analysis	22-180
Operating	7.2-32.8	Biology	8-28
Inertial Reference Unit		Meteorology	7.0
Electronics	42-138.0	X-Ray Fluorescence Spectrometer	2.6
Heater	125.0	Upper Atmosphere Mass Spectrometer	12.3
Terminal Descent and Landing Radar	70.0	Ambient Pressure	0.2
Radar Altimeter (1 or 2)	25.0	Stagnation Pressure	1.0
		Retarding Potential Analyzer	3.1

of the various Lander loads that are switched ON and OFF by relays contained within the PCDA. Loads other than those used during descent have been included for completeness. Double entries under the "watts" column show the operating power range of any given load for various operating modes. The unit variations for Lander 1 and 2 were less than 3%.

E. PROPULSION SUBSYSTEM

The RCS/deorbit and terminal descent propulsion systems performed without anomalies on both Landers. Thrust levels and specific impulses were within expected tolerances. Tank pressures were higher during blowdown than predicted, resulting in additional thrust margin.

1. RCS Deorbit Performance

The RCS/deorbit propulsion system provided attitude control and deorbit thrust from separation to parachute deployment. A summary of propellant used is given in Table V-13. Estimates were calculated based on both tank temperatures and pressures. The temperature-derived propellant-used data are given in Table V-13. These data are considered the most accurate and the most consistent. Analysis of the data indicates that all engines fired when commanded without valve failure and attitude rates verify that no measurable valve leakage occurred.

Table V-13 RCS/Deorbit Propellant Usage Summary

Item	Lander 1 Estimated	Lander 2 Estimated	Predicted
Vehicle Separation Weight, lb	2330	2326	NA*
Initial Propellant Load, lb	187	187	NA
Deorbit Consumption, lb	163	161	162
Coast and Entry Consumption, lb	4.6	3.6	4
Usable Margin, lb	17.4	20.5	18.8
*NA = Not applicable.			

2. Terminal Descent Performance

The terminal descent propulsion system provided thrust during terminal descent for the soft landing and roll control during the parachute and terminal descent phases. Table V-14 summarizes the amount of propellants used during this phase.

Table V-14 Terminal Descent Propellant Usage Summary

Item	Lander 1	Lander 2	Predicted*
Initial Vehicle Weight, lb	1498	1496	NA†
Initial Propellant Load, lb	185	185	NA
Consumption, lb	151.9	152.0	147.7
Usable Margin, lb	28.3	28.2	32.5
Final Vehicle Weight, lb	1345	1347	NA
*Assumed mean atmosphere and no winds. †NA = Not applicable.			

Of the propellant consumed, it is estimated that 0.5 lb was used for roll control on each Lander. A review of throttle valve positions indicates the largest difference between commanded and achieved valve position was 0.5%, which indicates low valve hysteresis at all positions. Excellent agreement between predicted thrust and calculated force verifies that the terminal descent engines performed as expected by providing nominal thrust and specific impulse.

F. THERMAL SUBSYSTEM

The thermal subsystem performed nominally from separation through landing. All component temperatures were within flight acceptance test limits and structural temperatures were within design limits. All propulsion system thermostatic heaters operated normally.

At touchdown, internal temperatures were generally 4 to 8°F cooler than predicted. Because the Lander interior is an insulated compartment, its temperature is primarily dependent on component power consumption and only slightly on external environmental factors during the brief separation-to-landing sequence. As previously noted, the total power consumption was below expectations, which was consistent with the lower temperatures experienced.

During the deorbit burn sequence, the base cover temperatures rose approximately 70°F, considerably less than the 300°F rise predicted using worst-case plume heating assumptions. This indicated the assumptions were quite conservative. Consequently, other external components did not warm up as much as expected during this time.

The aeroshell and base cover temperature response to the entry environment was different than predicted. The aeroshell backface temperatures

were as much as 200°F cooler than predicted by the simulation program, which had assumed worst-case atmospheric conditions and minimum ablator performance. The base cover temperatures were much hotter than predicted. This was to be expected considering the previously discussed results which had shown base cover heating rates nearly double the design value (Table V-6). The base cover inner and outer ring temperatures are shown in Figures V-5 and V-6.

From entry through touchdown, temperatures of all exterior components (IRU, RAE, TDLR, etc) were as expected.

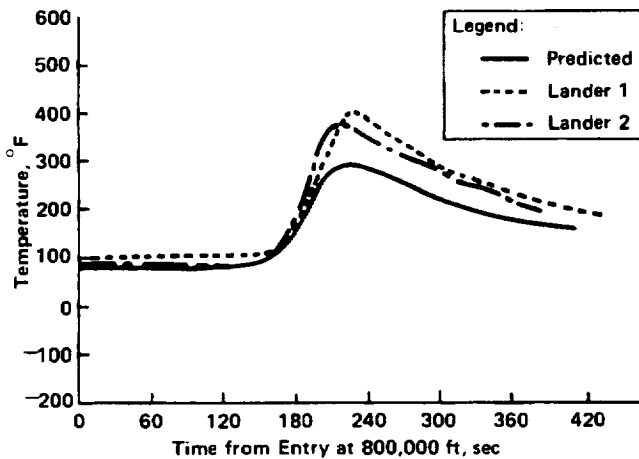

Figure V-5 Base Cover Inner Ring Entry Temperatures

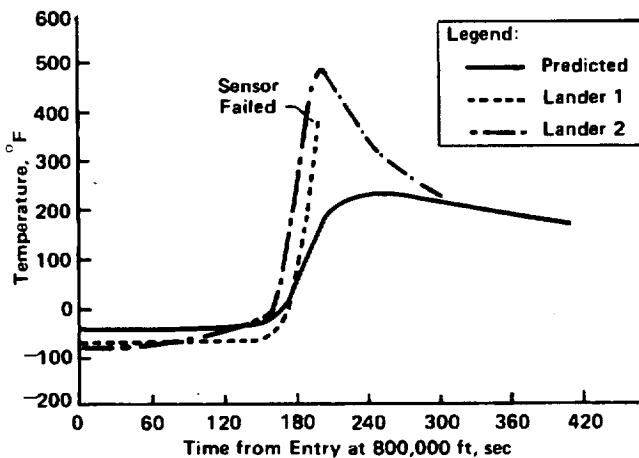

Figure V-6 Base Cover Outer Ring Entry Temperatures

G. PYROTECHNICS SUBSYSTEM

The operation of the pyrotechnic subsystem is difficult to quantize, although the quality must have been excellent since all 29 Lander pyrotechnic events occurred exactly as planned. The small amount of engineering telemetry data available indicated nominal LPCA performance. All pyrotechnic events were implemented by commands from the GCSC. These events and associated devices in the order they occurred in this phase are tabulated in Table V-15. After the initial landed pyrotechnic functions were completed, both LPCAs were powered down for the remainder of the mission.

Table V-15 Lander Pyrotechnic Functions

Event	Pyrotechnic Function
Separate Lander	Fire 3 Separation Nuts
Start Deorbit Bleed-In	Open 1 Valve
Enable Deorbit Propulsion	Open 1 Valve
Separate UAMS Cover	Fire Rotary Cutting Device
Start Terminal Bleed-In	Open 1 Valve
Deploy Stagnation Temp Sensor	Fire Bolt Cutter
Deploy Parachute	Fire Parachute Mortar
Separate Aeroshell	Fire 3 Separation Nuts
Enable Terminal Roll Control	Open 2 Valves
Release Lander Legs	Fire 3 Pin Pullers
Enable Terminal Propulsion	Open 3 Valves
Separate Parachute	Fire 3 Separation Nuts
Stop Terminal Propulsion	Close 2 Valves
Release HGA	Fire 1 Pin Puller
Enable Camera Duster	Open 1 Valve
Release Biology PDA Cover	Fire 1 Pin Puller
Release Meteorology Boom	Fire 1 Pin Puller

H. STRUCTURES AND MECHANISMS SUBSYSTEM

All Lander structure and mechanism subsystem elements performed in a very nominal manner. Their general performance is summarized by phase.

1. Separation

Separation of the Landers from the bioshield base/Orbiter was very smooth. Axial separation rates were 0.25 ft/sec on Lander 1 and 0.33 ft/sec for Lander 2, as compared to an expected maximum of 0.6 ft/sec. Lateral velocities, tipoff rates, and roll rates were negligible.

2. Entry

Aeroshell and base cover performance during entry was excellent. Loads and heating results are given in Table V-6 (in Section A). The overall aerodynamic performance was better than expected because of high lift-to-drag ratios and the aeroshell/base cover combination provided atmospheric entry protection and reduced vehicle velocities as required.

3. Parachute Operation

Parachute deployment was nominal with mortar impulse providing velocity increments of 4.6 ft/sec for Lander 1 and 5.05 ft/sec for Lander 2 (5.04 ft/sec was expected). Vehicle disturbance caused by deployment damped with time so that peak rates at aeroshell separation were well within the 30 deg/sec allowable. Aeroshell separation was nominal with any tipoff transients masked by the dynamic motion of the parachute/Lander combination. Parachute inflation was accomplished within 0.6 sec after line stretch, somewhat faster than expected. Parachute drag was also somewhat higher than expected. No parachute coning was detected. Base cover/parachute separation was very nominal with no recontact with the Lander body observed.

4. Landing

The landing legs performed their functions perfectly, permitting a soft landing and providing a stable platform for landed operations. Table V-16 summarizes landing leg stroke and footpad surface penetration. The Lander 1 data indicate that leg 2 probably touched the surface first with legs 1 and 3 then touching. At a landing velocity of 8.2 ft/sec, a stroke of approximately 3 in. could be expected by legs 1 and 3, which would impact the surface somewhat harder than the first leg that touches. The data from Lander 2, however, are somewhat inconsistent. These data indicate that leg 3 probably touched first and because of the small stroke, a sizeable rock may be partially supporting the Lander somewhere under the body or propellant tank near leg 3. This speculation is also supported by the fact that the Lander 2 body is tilted up approximately 8.2 deg in the general direction of leg 3. Whatever the cause, no damage has been observed and the landed operation has been completely nominal.

In the first few minutes following the landings the high-gain antenna and meteorology boom were deployed. Eventual operation of the antenna and

Table V-16 Landing Leg Operation

Leg	Lander 1		Lander 2	
	Stroke, in.	Surface Penetration, in.	Stroke, in.	Surface Penetration
1	2.8	*	1.1	*
2	1.3	6.5	2.8	Negligible
3	3.3	1.4	0.4	Negligible

*Neither camera 1 or 2 can image leg 1 footpad.

meteorology sensors and images of these components concluded that the deployment operations were exactly as required. This concluded the active operations of the Lander structures and mechanisms subsystem.

I. SCIENCE SUBSYSTEM

The Lander science instruments that operated during the separation-through-landing time frame consisted of:

- 1) Entry science (RPA, UAMS, pressure, and temperature sensors);
- 2) Camera 2 (initial landed);
- 3) Meteorology boom deployment (after touchdown);
- 4) Biology PDA cover deployment (after touchdown).

Each of these instrument operations is discussed in the following paragraphs.

1. Entry Science

The purpose of the entry science investigation was to characterize the Martian atmosphere both physically and chemically during the entry phase of the mission.

Table V-17 outlines the entry science sequence of events starting with deorbit burn. Entry science measurements terminated at touchdown. The sequence is described as follows. Deorbit burn began at separation + 7 min. Approximately 3 min after the deorbit burn, the upper atmosphere mass spectrometer (UAMS) cover on the aeroshell was separated by its pyrotechnically operated cutter, and its ion pump was powered on. During the coast period the RPA was operated periodically. On Lander 1, 18 retarding potential analyzer (RPA) sequences were performed, where a sequence was initiated every 6 min 29 sec, and 71 sec of data (142 frames of format 2A) were acquired. On

Lander 2, the operation was identical except the sequence was initiated every 6 min 20 sec.

Table V-17 Entry Science Sequence of Events

Sequence	Event
Deorbit burn + 3 min	UAMS cover separated. UAMS ion pump powered on. Initiate RPA intermittent sampling.
Entry - 60 min	UAMS power on.
Entry - 40 min	UHF powered in 10 watt mode. Initiate RPA continuous sampling. Initiate UAMS sampling.
Entry - 12 min	Tape recorder power on.
Entry - 10 min	Pressure sensors on (ambient and stagnation).
Entry (0.05 g)	UAMS and RPA power off.
1.1 km/sec relative velocity	Stagnation temperature probe deployed.
5.9 km above local terrain + 6 sec	Stagnation pressure instrument off.
Aeroshell separation + 12 sec	Lander legs deployed. Foot pad temperature sensor deployed.

At entry - 60 min, the UAMS was powered on for a 30-min warm-up. The UHF was powered in the 10-watt mode at entry - 40 min. At the same time RPA continuous sampling and UAMS sampling were initiated. At entry - 10 min the pressure sensors on the aeroshell and Lander were powered on. When 0.05 g was sensed, the UAMS and RPA were powered off. When 1.1 km/sec relative velocity was computed, the temperature probe on the aeroshell was deployed through the heatshield. Probe deployment was initiated by a cartridge-actuated bolt cutter that releases a spring to extend the probe. Useful temperature data were acquired until aeroshell separation. Six seconds following sensing of 5.9 km above local terrain the pressure instrument on the aeroshell was powered off. The Lander pressure sensor continued to acquire data through touchdown. Twelve seconds after aeroshell separation, the Lander legs were deployed. At that time, the footpad temperature sensor began collecting useful data and did so through touchdown.

All of the entry science instruments on both Landers performed in a nominal fashion.

The engineering data returned from each UAMS showed good agreement with that obtained both before launch and during the cruise check-outs. These data showed the instruments operated normally and in good health. Each sealing cap cutter mechanism worked as planned. The mass spectra obtained from both instruments were of good quality although those obtained from the Lander 2

instrument exhibited somewhat more noise than those from Lander 1. Lander 2 appears to be generally noisier than Lander 1. The RPA on Lander 2 exhibited more noise in the data than that on Lander 1 and other instruments on the Lander appear to be more affected by noise on Lander 2 than Lander 1.

Housekeeping and science data from both RPA instruments indicated normal operation and sequencing.

The RPA and UAMS instruments showed good agreement with each other in areas where the same science parameters can be determined from the data from each instrument. Good agreement with the lower atmospheric data was inferred.

Both pressure instruments and both temperature instruments on each Lander operated in a nominal fashion. These instruments do not provide any direct engineering information, but all of the data gathered were self-consistent and in good agreement with pressure and temperature data inferred from the measured spacecraft trajectory parameters during descent to the surface.

The parachute phase temperature instruments, which are mounted on a footpad on each Lander, survived the landings.

2. Camera 2 (Initial Landed)

At 25 sec after touchdown, a real-time imaging sequence, using camera 2, was initiated. Two pictures were acquired: a 60-deg high-resolution image of footpad 3 and a 300-deg survey panorama image. For both Landers, the camera performance was outstanding, with images of excellent quality received on Earth shortly after landing.

3. Meteorology Boom Deployment (after Touchdown)

By 7 min after touchdown, the meteorology boom was deployed by firing a pin puller. The camera 2 survey panorama acquired after touchdown verified that the meteorology boom had deployed.

4. Biology PDA Cover Deployment (after Touchdown)

Approximately 6 min after landing, the biology processor and distribution assembly (PDA) cover was opened by a pyrotechnic pin puller. Nominal deployment was verified by imaging data.

ORIGINAL PAGE IS
OF POOR QUALITY

VI. LANDED OPERATIONS

- A. Guidance and Control Subsystem
- B. Communications Subsystem
- C. Telemetry Subsystem
- D. Power Subsystem
- E. Thermal Subsystem
- F. Science Subsystem

Photograph on the left shows Lander 2 surface sampler boom in the process of moving a rock on October 8, 1976. Photograph on the right shows displaced rock after move.

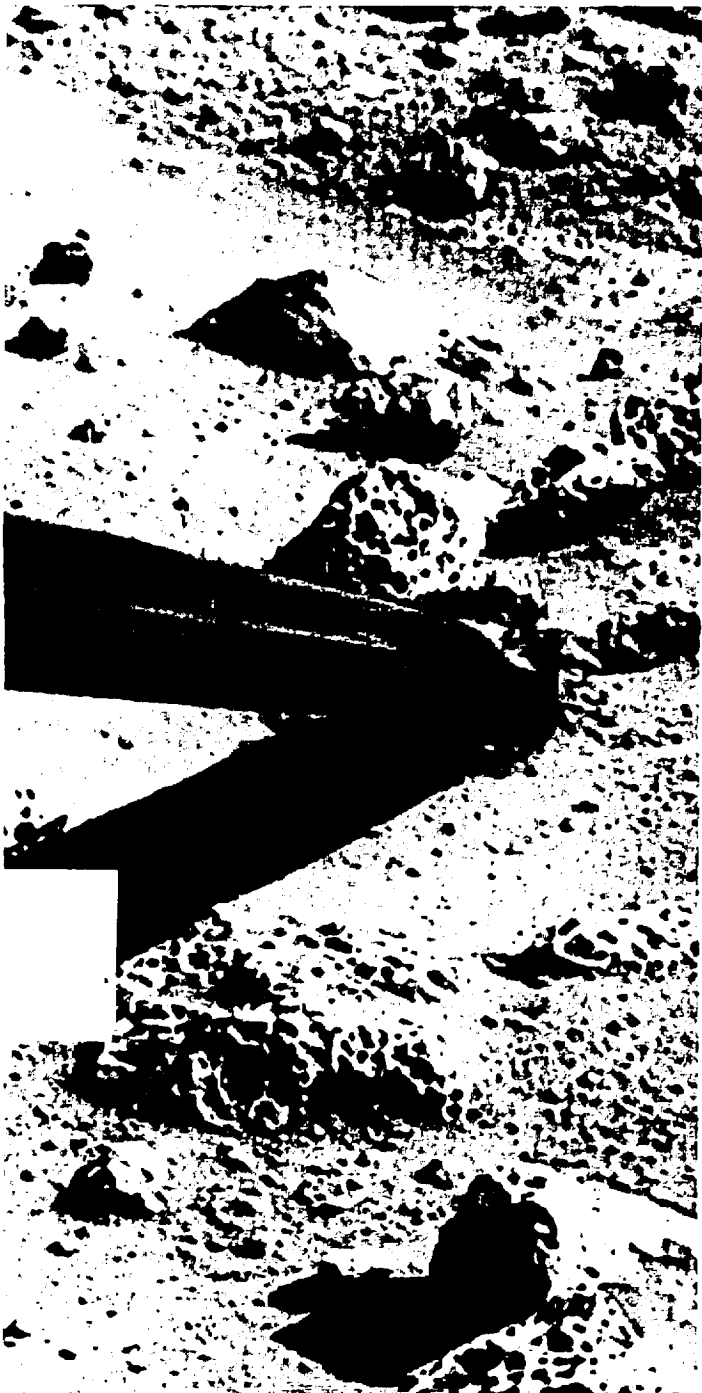

VI. LANDED OPERATIONS

Viking Landers 1 and 2 landed on Mars on July 20, 1976 and September 3, 1976, respectively. From the time of touchdown until the time of conjunction a proliferation of data was acquired by both vehicles and transmitted to Earth.

Nine scientific investigations were conducted on the surface of Mars. The purposes of these investigations were to:

- 1) Search for living organisms present in Martian surface material (Biology Investigation);
- 2) Search for and identify organic molecules in the Martian surface material (Molecular Analysis Investigation);
- 3) Determine the atmospheric composition at the surface of Mars (Atmospheric Analysis Investigation);
- 4) Visually characterize the Martian landscape and the atmosphere (Imaging Investigation);
- 5) Determine the elemental composition of the surface material (Inorganic Chemical Investigation);
- 6) Determine temperature, pressure, and wind speed and direction and their temporal variations at the Martian surface (Meteorology Investigation);
- 7) Determine the level of tectonic activity (Seismology Investigation);
- 8) Determine the physical characteristics of the Martian soil (Physical Properties Investigation);
- 9) Estimate the abundance of magnetic particles in the surface material and identify the types that are present (Magnetic Properties Investigation).

To perform these investigations, seven instruments were operated extensively throughout both landed missions. On Lander 1, a 43-sol primary mission was conducted. Prior to the landing of Lander 2, Lander 1 was placed in a reduced mission mode, which continued until conjunction (approximately sol 108). On Lander 2, a 61-sol primary mission was performed. Figures VI-1 and VI-2 summarize the Lander 1 primary mission and reduced mission, respectively. Figure VI-3 summarizes the primary mission for Lander 2.

The performance of the Landers can almost be summarized by the amount of data acquired and

the number of experiments conducted. On Lander 1, the surface sampler collected 12 samples: three for the biology experiment, three for GCMS (only two were analyzed), and six for XRFS. With these samples the biology instrument performed four analysis cycles, the GCMS performed two analyses on the first sample and three on the second, and XRFS conducted a total of 73 sequences. The Lander cameras were operated almost daily for a total of approximately 6.84×10^8 bits of recorded data. In addition, the cameras provided real-time imaging during many of the direct and relay links. A total of 24 atmospheric analyses were performed: four filtered, 15 unfiltered, and five enriched sequences. The meteorology instrument collected data daily to a total of approximately 1.2×10^8 bits of data. Even though the seismometer failed to uncage, a total of 500 buffer dumps per sol were collected for 18 sols and 83 buffer dumps per sol for 25 sols. The surface sampler conducted one experiment exclusively for physical properties and magnetic properties. In addition, these two investigations received support from imaging data collected for surface sampler operations and from engineering data collected by the surface sampler and other Lander hardware (physical properties only).

On Lander 2, the surface sampler acquired 16 samples: three for biology, two for GCMS, and 11 attempted acquisitions for XRFS. One sample for both biology and GCMS was collected following a rock-push sequence. The biology instrument performed three analyses, the GCMS conducted four analyses on the first sample and five on the second, and XRFS performed a total of 32 sequences. Sixteen atmospheric analyses were performed. The cameras were operated almost daily for a total of approximately 8.1×10^8 bits of recorded data in addition to the real-time imaging during direct and relay links. The meteorology and seismology instruments were operated daily for a total of 9.7×10^7 bits and 2.4×10^8 bits of data, respectively. The surface sampler conducted one sequence for physical properties and magnetic properties.

The return of data to Earth from the Landers during the primary landed missions was almost overwhelming. Lander 1 returned approximately 1.8×10^9 bits and Lander 2 returned 2.5×10^9 for a total of 4.3×10^9 bits.

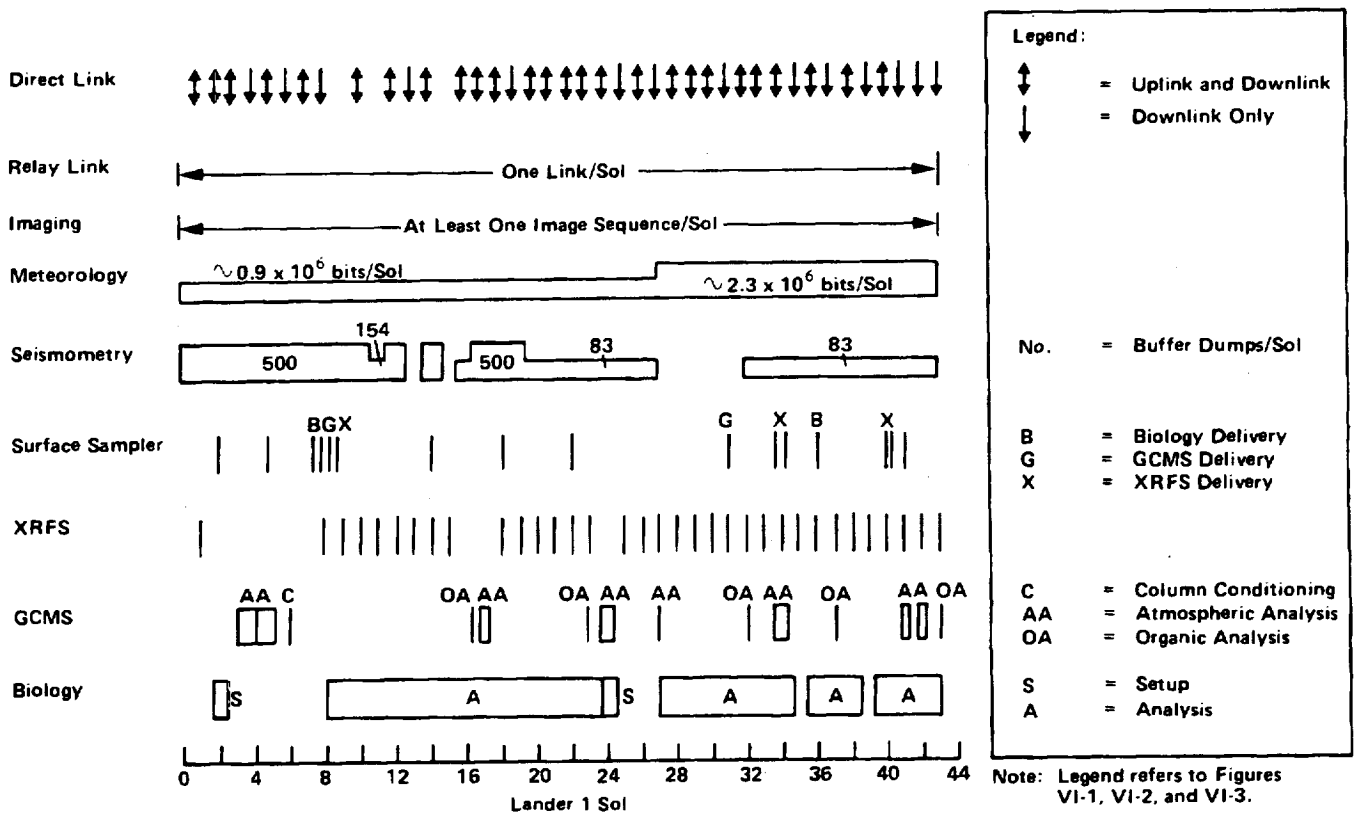

Figure VI-1 Lander 1 Primary Mission Activities

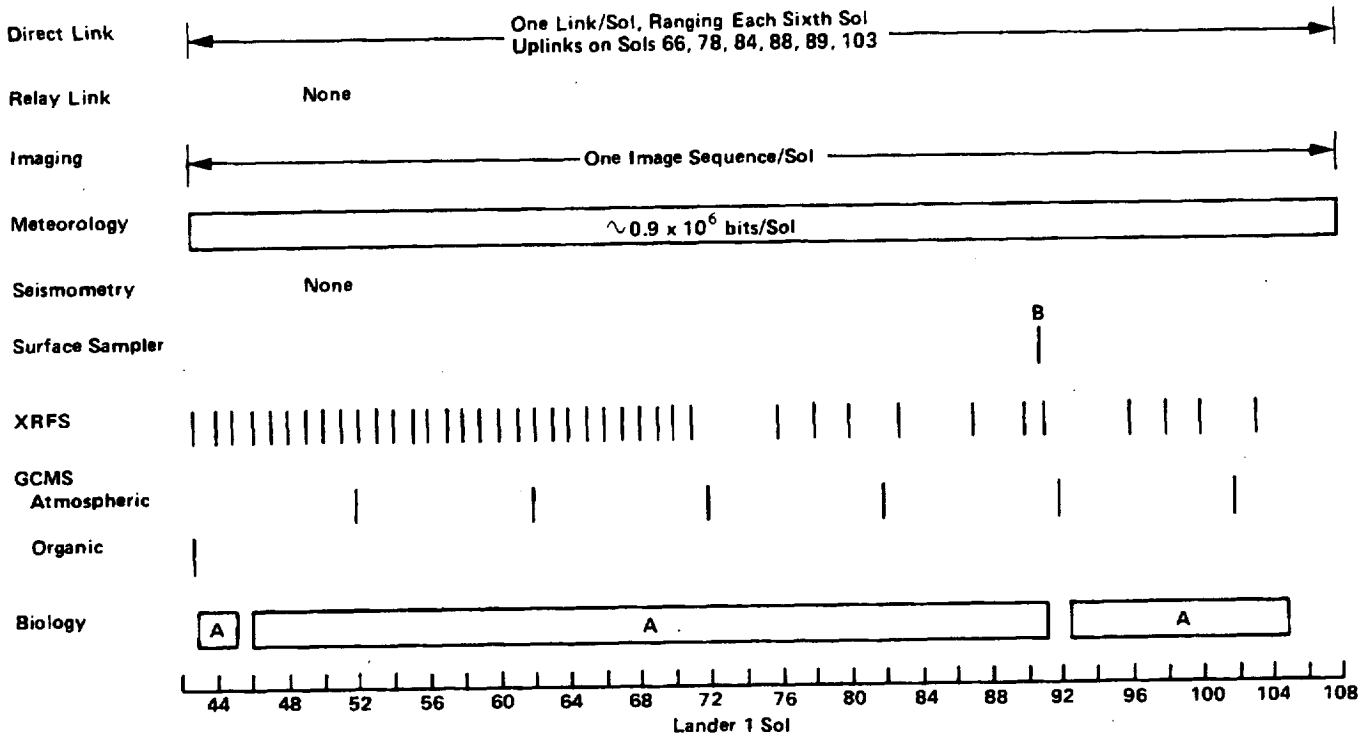

Figure VI-2 Lander 1 Reduced Mission Activities

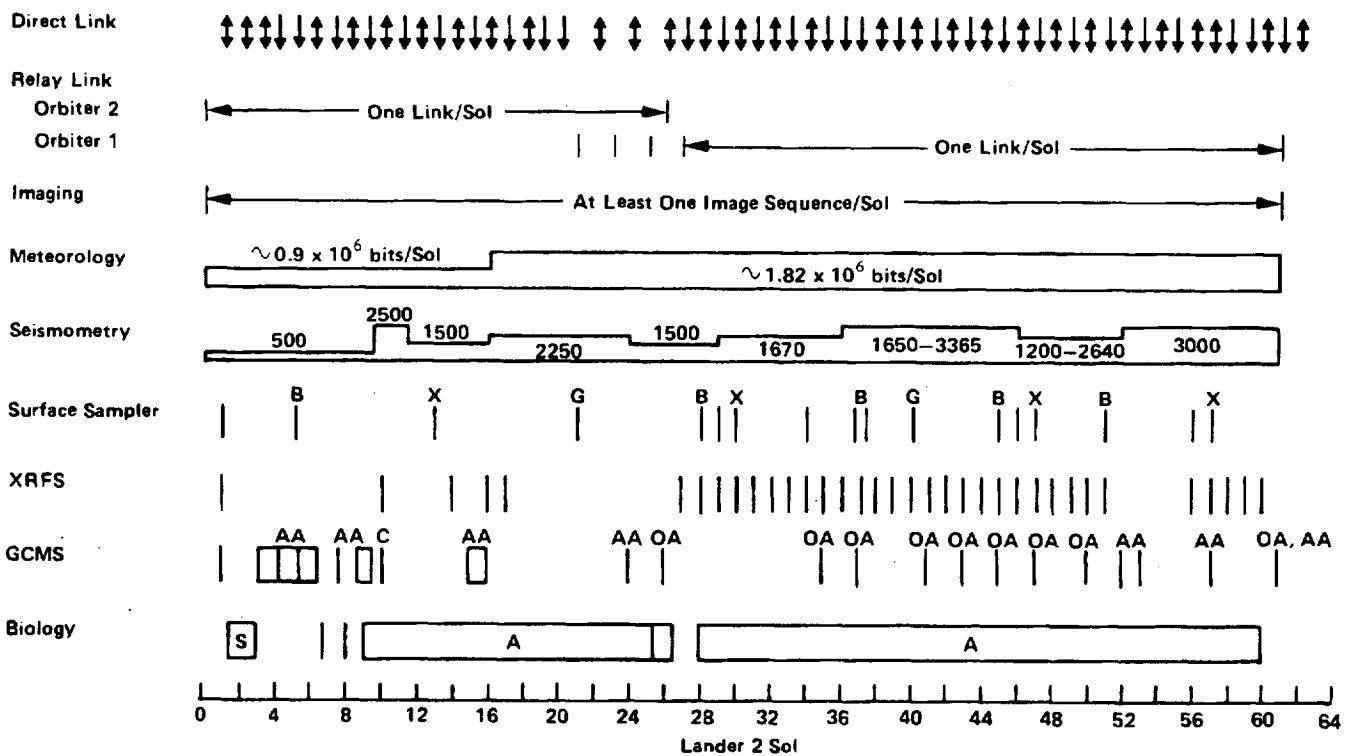

Figure VI-3 Lander 2 Primary Mission Activities

A. GUIDANCE AND CONTROL SUBSYSTEM

During the initial landed operations (the 5 minutes or so following touchdown), all guidance and control components except the GCSC were powered down and remained off for the remainder of the landed mission. The GCSC was the "brains" of the Lander, controlling all events and receiving frequent software updates from the Earth-based flight team. Although prelaunch and cruise operations had indicated that both GCSC A and B on each Lander were completely functional, GCSC A was arbitrarily selected for both Landers and was used throughout the primary missions.

The flight software that controlled the landed mission was originally loaded in the GCSC at KSC. This software was updated before separation to include all of the latest mission planning and exact entry parameters for the selected landing sites. Lander 1 software was revised to be mission 1 and Lander 2 software was changed to mission 2. Lander 2 was originally planned to launch first and would have accomplished mission 1. However, launch vehicle and Orbiter problems delayed Lander 2 and Lander 1 was launched first. It was not necessary to revise the software before launch

and the update was made about a month before the Landers separated from the Orbiters. The flight software was designed to allow updating of mission design data (sequencing times, DAPU mode changes, etc) by the flight team through the direct uplink during the landed mission. This was done every other day during the primary mission as normal activity. Nonstandard changes for engineering data were also made. Finally, changes to the basic software logic (code changes) were also made. The logic changes were independently verified by the Lander Support Office, usually on the proof test capsule, prior to uplinking. This flexibility was a very strong feature of the software design because it could adapt the Lander to changing mission environments. It allowed the flight team to respond quickly to hardware failures, near-real-time interpretation of data, and changes to mission priorities. The Lander Support Office and flight team processed 70 software changes and uplinked them without error. The flexible input-output and scheduling algorithms provided by the flight software design allowed data base changes to be made accurately and quickly.

At the end of the primary mission, 842 message segments had been uplinked to Lander 1

GCSC A, 378 to Lander 1 GCSC B, 921 to Lander 2 GCSC A, and 328 to Lander 2 GCSC B. Since a typical message segment contained up to 30 GCSC words, over 60,000 words were updated in the GCSCs without problems.

Mechanically, the GCSCs also performed in a flawless manner. These functions included control of all power switching of Lander components, scheduling of direct and relay communications, pointing of the high-gain antenna, scheduling of all science experiments, and control of all DAPU modes. Additionally, the GCSC reset a timer in the PCDA once a minute to indicate nominal performance and prevent switching to the alternate GCSC. The GCSC also periodically refreshed its own memory by reading and writing back each cell in memory. The daily memory read outs during the primary missions revealed no unexpected mismatches. The accuracies of the GCSC clocks were also well within specified requirements; both clocks were fast by approximately 1 sec/sol.

The GCSCs performed all of the above functions and no anomalies were observed in either GCSC on either Lander.

B. COMMUNICATIONS SUBSYSTEM

1. Landed Direct Communications System (DCS)

The high-gain antenna (HGA) under control of the GCSC pointing program traveled from the initial deployed position to a predetermined park position of 88-deg elevation and 30-deg azimuth approximately 2.5 hr after landing. This position was selected before separation so that the Earth would

pass through the beamwidth of the HGA at the scheduled time of the daily DCS downlinks in the event of a HGA mechanical drive failure. This "park" position was changed on sol 66 for Lander 1 and sol 32 for Lander 2 to leave the HGA at each previous sol's end-of-track position to reduce HGA stepping and maximize lifetime.

The DCS sequence implemented for the first several landed sols is illustrated in Figure VI-4. An approximately 50-minute uplink frequency acquisition sweep, illustrated in Figure VI-5 was performed to acquire the Lander command receivers.

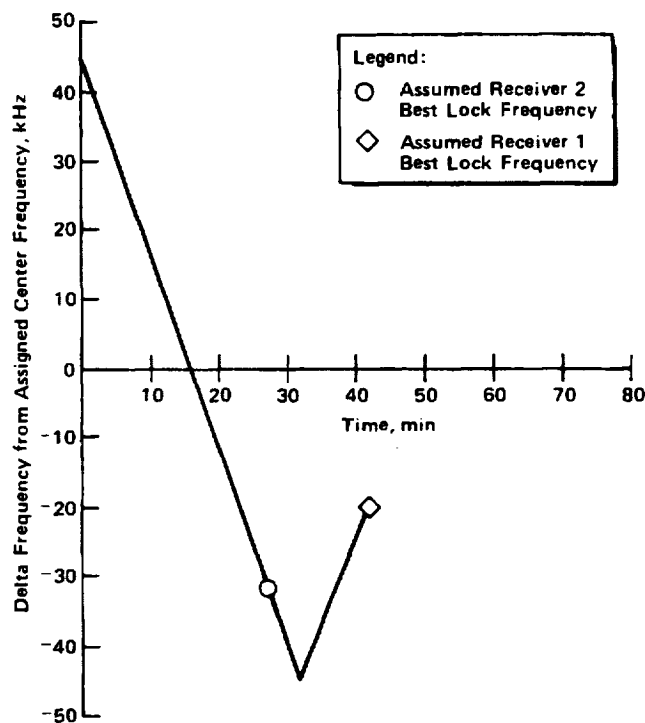

Figure VI-5 Typical S-Band Receiver Acquisition Sweep

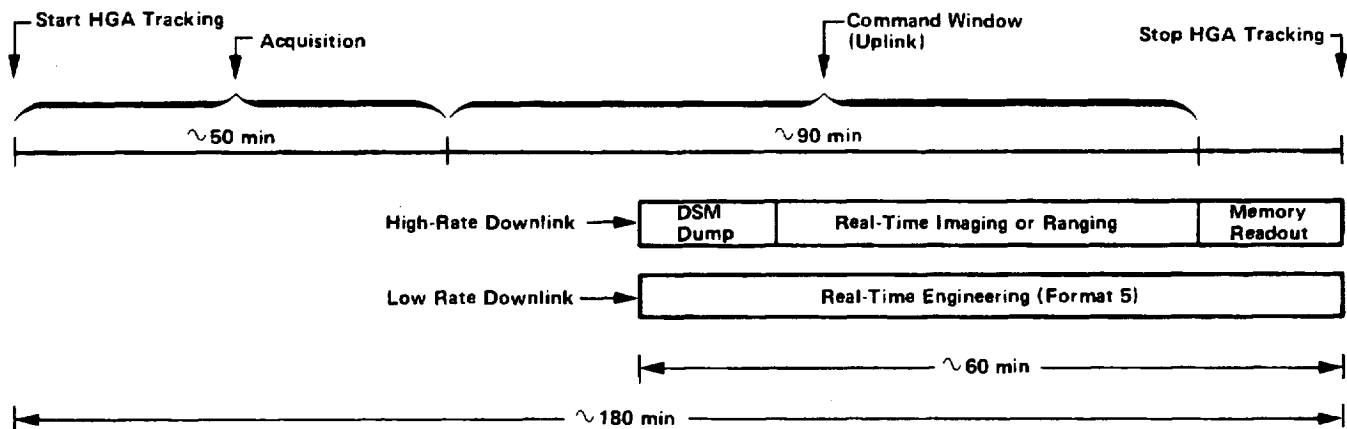

Figure VI-4 Typical Direct Link Sequence

The command strategy that involved the reception of the commands at the Lander coincident with the start of the Lander data downlink permitted the near-real-time verification of the command segments received and accepted by the Lander. An approximate 30-minute contingency command window was provided following termination of the DCS downlink, allowing enough time to retransmit any lost command segments on that same sol. However, due to the successful receipt of all command segments transmitted to the Landers, it was not necessary to use either the contingency command window or the receiver 1 emergency command window for the primary missions of Lander 1 or Lander 2.

Tension mounted as the time approached for the first scheduled DCS downlink; this would be the first time in nearly 11 months of space travel that the DCS radio equipment had been operated. It was originally planned to have only one command receiver, the one connected to the low-gain antenna, powered continuously throughout the landed mission to provide emergency command capability. The downlink data were acquired at the Goldstone DSN station on schedule. These data indicated that the low-gain antenna command receiver was not coherently locked with the uplink and apparently drifted into lock several minutes before the first commands were received. A review of the DCS status data indicated that the received signal level reading on that receiver was approximately 10 dB below the expected value; however, commands were being processed by that receiver. The HGA receiver 2 and the downlink radio equipment operated as expected throughout the primary mission. It was evident that a problem existed in the low-gain antenna receiver 1 command stream when receiver 1 failed to coherently acquire the uplink signal on sol 2. From sol 2 on all commands were processed through HGA receiver 2.

To determine the nature of the low-gain antenna receiver 1 problem, 12 additional acquisitions were attempted periodically when the mission timeline permitted. Increased DSN uplink power and very slow frequency sweep rates were implemented to offset the apparent 10 dB degradation, resulting in nine successful acquisitions, each one at a receiver temperature greater than 60°F. This correlation indicated that the failure was temperature dependent. However, additional acqui-

sition attempts at higher temperatures proved unsuccessful, indicating a permanent failure.

The Lander 2 DCS performed as expected through sol 32 using TWTA 2. A thermal analysis indicated that longer downlink durations could be realized by using TWTA 1 and this was implemented beginning on sol 33. On sol 39 the scheduled downlink was not received by the DSN, consequently, no real-time telemetry was received for diagnostic purposes. However, analysis of stored temperature data received via a later relay link indicated that the TWTA was powered during its 90-sec warm-up period and apparently ceased operation upon application of high voltage to the tube. Analysis of the ranging performance for sols 33, 35, and 37 (ranging days) indicated a degradation. In addition, it was found that the uplink command signal-to-noise ratio was slightly degraded on sols 33 through 38. Based on a similar failure during TWTA development and the above degradations, it is believed that TWTA 1 experienced corona in the high voltage power supply, which ultimately caused a high voltage arc-over on sol 39. The over-current protection circuit within the TWTA power supply automatically removed the TWTA from the Lander power bus. Also, the corona protection circuits between the TWTAs and the telemetry subsystem prevented possible damage to the telemetry subsystem. The Lander 2 sequence was changed to use TWTA 2 on sol 63; it performed as expected throughout the remaining primary mission. The TWTA on Lander 1 has performed flawlessly throughout the mission.

Other than the above described anomalies, the DCSs of both Landers performed exceptionally well during the entire primary missions. The Lander 1 downlink performance was sufficiently above the predicted nominal level to allow a data rate increase from 250 bps to 1000 bps for sols 44 through 84. This rate was later reduced to 500 bps to offset solar corona degradation of the downlink. Similarly, the Lander 2 data rate was increased to 500 bps on sol 63. Both Landers supported 500 bps links until the Landers were reconfigured for the solar conjunction radio science experiments. A typical example of the downlink signal-to-noise-ratio (SNR) and bit-error-rate (BER) performance for the Landers is illustrated in Figure VI-6. Typical command performance for the Landers is illustrated in Figure VI-7.

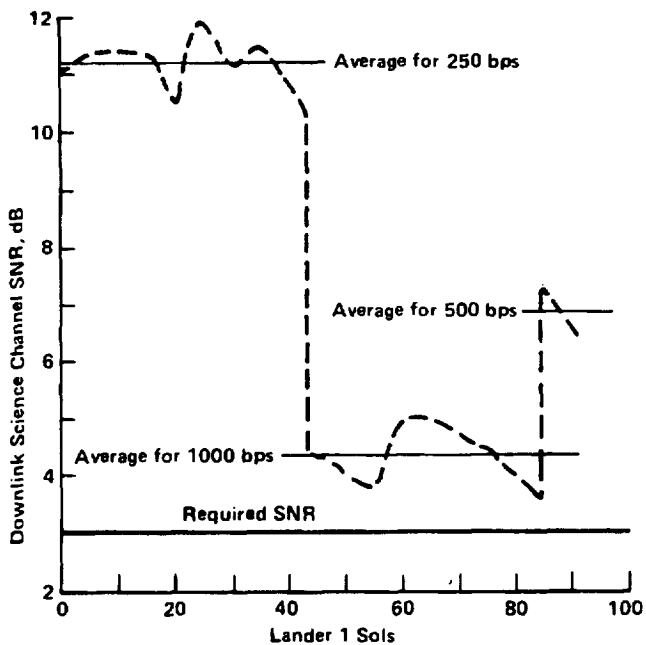

Figure VI-6 Lander 1 Downlink Science Channel Signal-to-Noise Ratio

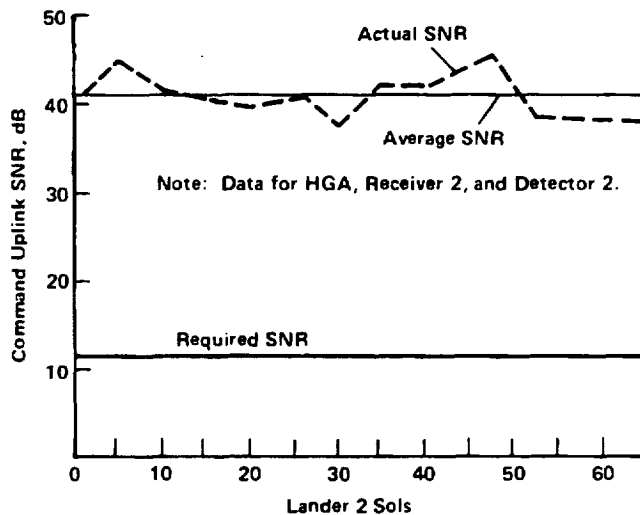

Figure VI-7 Lander 2 Command Channel Signal-to-Noise Ratio

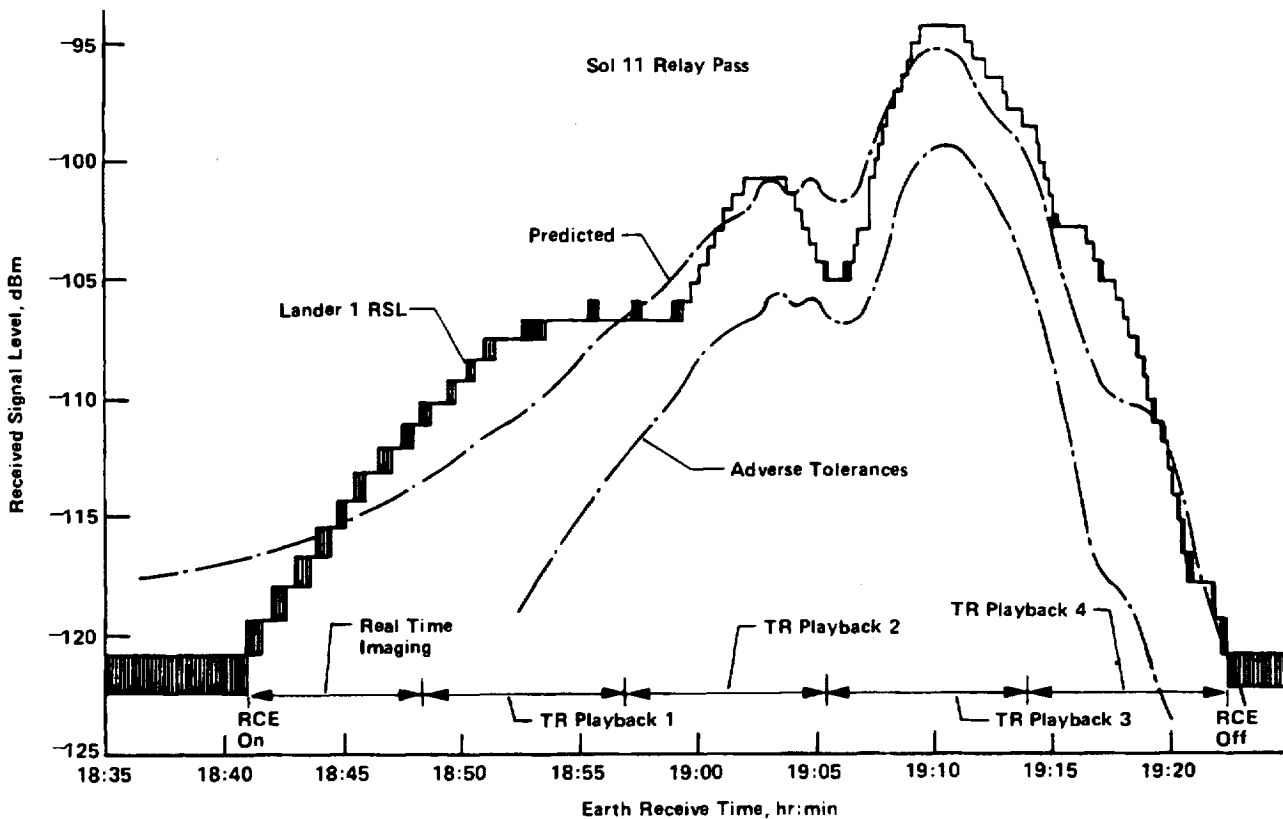

Figure VI-8 Typical Lander 1/Orbiter 1 Relay Link

2. Landed Relay Communications

Based on the observed performance of the initial landed relay link, confidence was high that the sol 1 relay link would be nominal. This proved to be the case when approximately 3×10^7 bits of data were transmitted to the Orbiter at a rate of 16,000 bps. These data were received at the Orbiter, recorded and relayed to Earth within a few hours after leaving the surface of Mars. The UHF transmitter 30-watt power mode performed as expected, although it had not been tested since the vehicles were mated before launch. Typical Orbiter 1/Lander 1 relay link performance is shown in Figure VI-8.

However, the success was short lived for Lander 1 when the UHF transmitter came on in the 1-watt power mode for the two subsequent relay passes. The relay link sequence preprogrammed for the first 11 sols featured the redundant playback and transmission of the Lander recorded data, preventing the loss of critical data. The problem was suspected to be noise susceptibility of the power mode control logic in the transmitter. A command uplink was prepared that modified the Lander sequence to place the GCSC control logic in a state that reduced the noise susceptibility on the GCSC/transmitter power mode control interface. On sol 4, one sol before implementing the modified Lander sequence, the transmitter functioned in the programmed 30-watt power mode, further supporting the noise susceptibility theory. The UHF transmitter performed as expected until about 1 week prior to the end of the primary mission for Lander 1. At that time telemetry data indicated a potential transmitter anomaly in the 30-watt mode. To avoid catastrophic failure and reduce the thermal stress to extend the trans-

mitter life for the follow-on mission, it was decided to use the 10-watt power mode for sols 40 through 43. Sol 43 was the last planned relay link for Lander 1 before the Lander 2 primary mission began.

Nominal hardware and link performance was also observed for the Orbiter 2/Lander 2 relay passes. This resulted in the return of over three times the required volume of scientific and engineering data from the surface of Mars. Typical performance for the Orbiter 2/Lander 2 relay links is shown in Figure VI-9. By sol 21 of the Lander 2 mission, Orbiter 1 was moved into position to support the Lander 2 relay links. This maneuver was in the mission plan to allow Orbiter 2 to leave its station over Lander 2 to conduct further scientific exploration of the planet. Test relay links from Lander 2 to Orbiter 1 were conducted on sols 21, 23, and 25, in addition to the planned Orbiter 2/Lander 2 links. Orbiter 1 took over sole support of the Lander 2 relay link on sol 27 and continued in this capacity for the remainder of Lander 2's primary mission. An interesting feature of the Orbiter 1/Lander 2 relay passes is that the relay link was initiated when the Orbiter was very close to the Lander horizon. The maximum elevation angle achieved by the Orbiter was approximately 25 deg. All previous relay links were initiated at approximately 5 deg elevation with the Orbiter passing nearly overhead of the Lander. The observed performance for a typical Orbiter 1/Lander 2 relay pass is shown in Figure VI-10. The larger differences between the observed and predicted performance shown in the figure are believed to be the result of surface reflections, surface ground plane effects, and the inherent error in the scale-model Lander antenna radiation pattern data at extreme aspect angles used for the performance predictions.

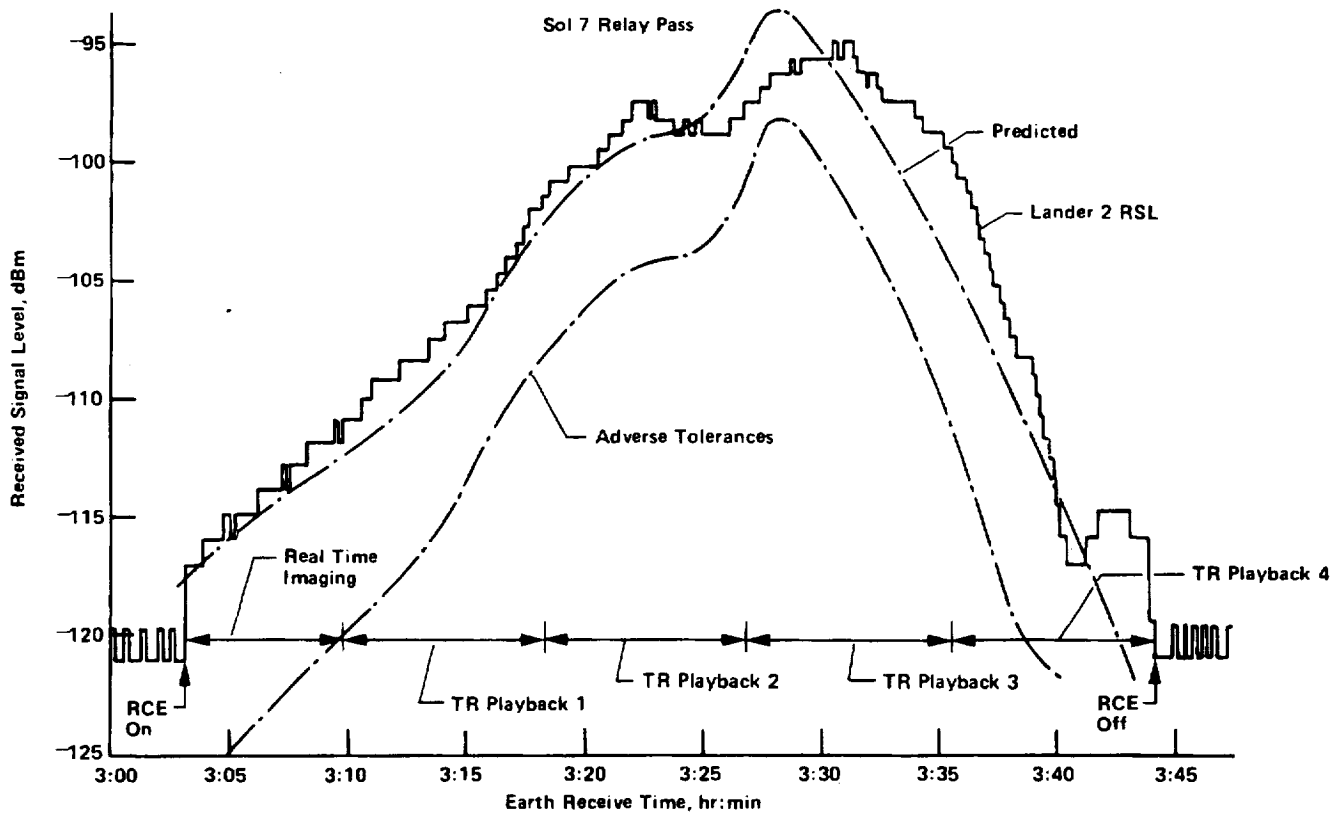

Figure VI-9 Typical Lander 2/Orbiter 2 Relay Link

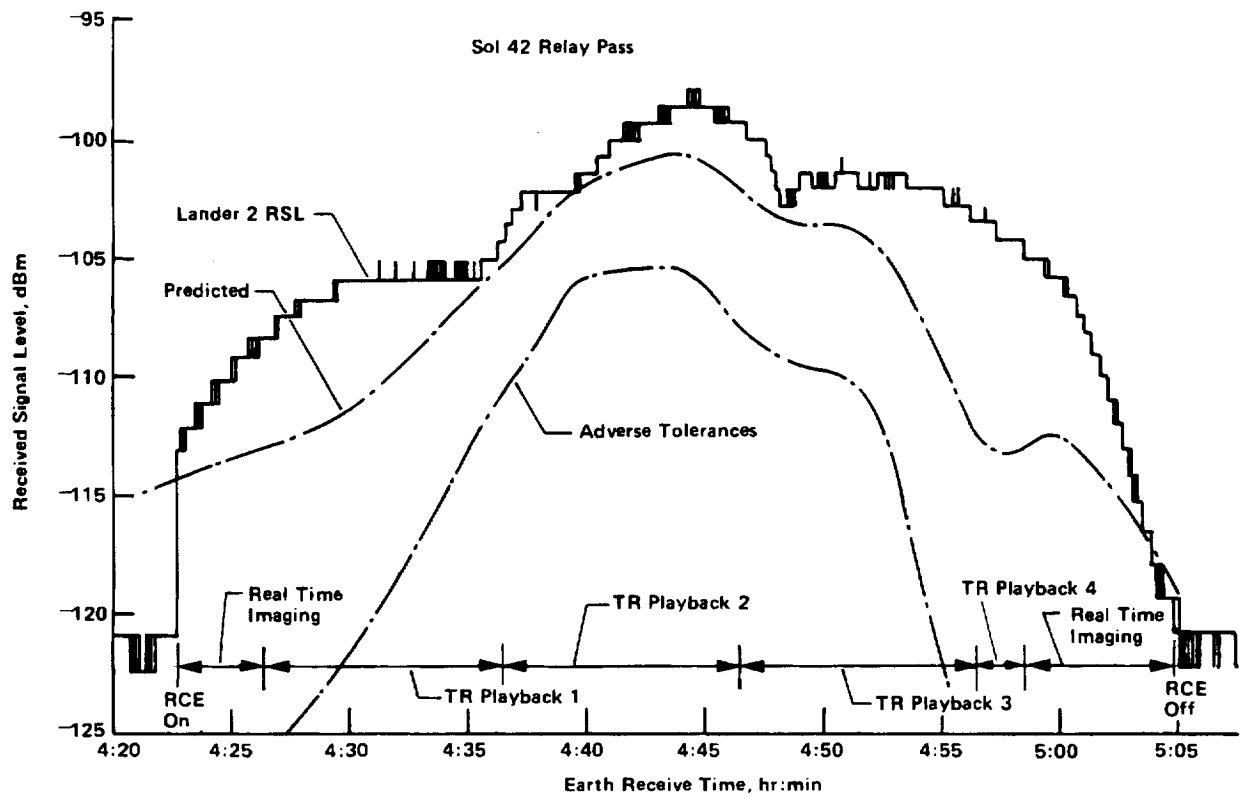

Figure VI-10 Typical Lander 2/Orbiter 1 Relay Link

C. TELEMETRY SUBSYSTEM

The telemetry subsystem functions during the landed mission were to collect, store, and enable data transmission upon command from the GCSC over the relay link or direct link.

Formats 4 and 5 were used for collection of engineering data during this mission phase. When the DAPU was commanded to format 4, it sequenced through that set of measurements once, stored the data in the DSM, and then stopped. This format was used to monitor the health of the Lander subsystems periodically throughout each sol. When format 5 was commanded, the DAPU acquired and transmitted engineering data continuously, as it sampled the measurements. This format was used during the relay link, typically interleaved between real-time imaging and tape recorder playbacks. Approximately 25% of these measurements monitored the communication subsystem performance. Transmission during the direct link used a two-channel system. One channel was devoted to format 5 at 8 1/3 bps, each measurement being sampled each 92 sec. The other channel transmitted science data from the tape recorder or DSM, imaging data, or GCSC memory readouts. The data rate for this high-rate channel was selectable via GCSC command and was revised based upon link performance. The most common rate used was 500 bps with some transmission at 250 and 1000 bps.

During the Lander 1 sol 3 direct link, the telemetry subsystem exhibited its first anomaly. A DAPU mode change was commanded from DT-6 (DSM readout) to DT-14 (imaging and format 5 to DSM). At that time, a drop in the signal-to-noise ratio in both the high- and low-rate channels was observed. This characteristic repeated itself on subsequent downlinks, at times causing loss of signal up to several minutes. Analysis of the problem revealed that the phase of the subcarrier clock in the DAPU changed by 90 deg when going to or from a DSM read mode. This sudden change in phase caused the DSN subcarrier demodulator to drop lock and then reacquire. The DSN subcarrier demodulator did not have sufficient bandwidth to compensate for the resulting instantaneous phase shift. The reacquisition time caused the apparent loss of data. This problem was resolved by extending the repeating GCSC memory readout following the DSM readout to 3 minutes, thereby allowing time for the DSN to lock up and still allow sufficient time for recovery of the memory readout data. After implementation of this operational procedure, no further problems were observed.

Except for the above relatively small problem, the telemetry subsystem performance was nominal during the primary landed mission.

D. POWER SUBSYSTEM

When the GCSC received the touchdown signal, it terminated the descent phase and initialized the Lander for landed operations. Power subsystem initialization included the following:

- 1) Safed the Lander pyrotechnic subsystem;
- 2) Disabled the entry bus (controlled power for components not required for landed mission);
- 3) Enabled landed battery charging cycle starting with battery A;
- 4) Enabled landed power system failure sensors and emergency sequencing system.

All Lander power initial operations were satisfactorily completed and nominal Lander power operation was established by sol 2.

During landed operations, power was supplied by the two RTGs with the batteries supplying power during short peak load periods. The batteries were then recharged when bus power requirements dropped below the RTG output level. The RTGs through the power converter supplied 68 to 70 watts for Lander use. When bus power requirements exceeded this level, the bus voltage dropped to a level where the batteries started to share the load with the converter output. The equipment bus operated in a 29- to 32-volt range, depending on bus load, when operating in this battery share mode. When the bus load decreased below the fixed RTG output power level, the bus voltage rose, and at 35 volts the PCDA chargers turned on and charged the battery connected to the charge bus at a charge rate determined by the excess power available. If the battery was already charged and the bus voltage rose to approximately 36 volts, the shunt regulators turned on and dumped excess power output to the load banks. During the landed mission, the battery charging sequence commanded one battery to the charge bus and then switched to the next battery on 1-hr intervals. This sequence was repeated continuously, alternating charging between battery assemblies to properly distribute thermal loads inside the Lander body. The three batteries not being charged were connected to the load bus and were available for bus load that exceeded the RTG converter output.

Table VI-1 lists the Lander 1 parameters monitored for power subsystem performance. The initial data are the average of the first 10 to 12 sols of the landed mission, while the final data are the average of the last 10 to 12 sols before conjunction

Table VI-1 Lander 1 Power Subsystem Performance

Measurement	Initial Data		Final Data	
	Min	Max	Min	Max
RTG Power Out, W	80	82	78	80.5
RTG Current, A	9.2	9.4	9.0	9.2
RTG 1 Pressure, psia	6.3	6.3	6.5	6.5
RTG 2 Pressure, psia	16.5	16.6	17.4	17.7
RTG 1 Root Temperature, °F	287	314	290	322
RTG 2 Root Temperature, °F	283	312	285	319
RTG 1 Junction Temperature, °F	988	1015	989	1020
RTG 2 Junction Temperature, °F	955	983	957	989
Battery A Temperature, °F	45	59	52	66
Battery B Temperature, °F	48	60	54	69
Battery C Temperature, °F	50	64	56	70
Battery D Temperature, °F	52	66	58	72

Table VI-2 Lander 2 Power Subsystem Performance

Measurement	Initial Data		Final Data	
	Min	Max	Min	Max
RTG Power Out, W	81	84	80.5	83.5
RTG Current, A	9.4	9.7	9.3	9.5
RTG 1 Pressure, psia	16.5	16.8	17.1	17.3
RTG 2 Pressure, psia	12.8	12.9	13.6	13.6
RTG 1 Root Temperature, °F	288	315	284	313
RTG 2 Root Temperature, °F	282	314	280	312
RTG 1 Junction Temperature, °F	976	1002	973	999
RTG 2 Junction Temperature, °F	965	993	963	991
Battery A Temperature, °F	55	67	49	62
Battery B Temperature, °F	55	68	49	62
Battery C Temperature, °F	59	71	52	65
Battery D Temperature, °F	60	73	54	66

(sol 109 for Lander 1). The min/max data primarily reflect the diurnal affect of the Martian environment.

A comparison of initial and final data shows a slight increase in temperatures and pressure and decrease in power as the RTGs slowly degrade. Other discrete and regulated data indicate that all power

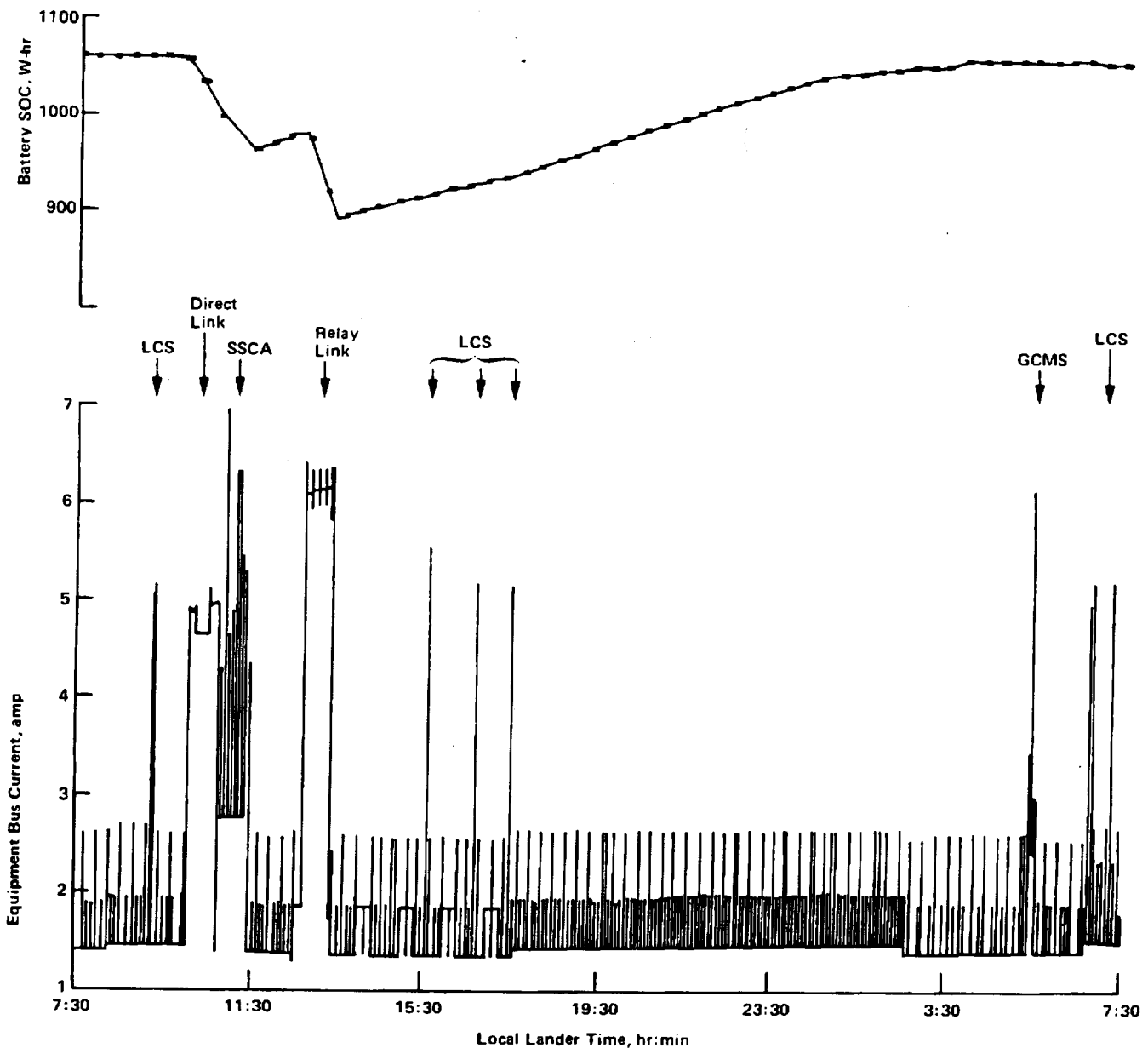

Figure VI-11 Lander Power Profile during Busy Sol

components operated nominally and well within specification limits.

Table VI-2 lists the power subsystem performance for Lander 2. These data also show the slow RTG degradation. All Lander 2 data indicate nominal power subsystem operation.

Figure VI-11 is a typical "busy" sol showing Lander activities from about 7:30 a.m. in the Martian morning. The average EQBUS I (equipment bus current) of approximately 1.4 amp is the sum of the continuous bus loads, such as the PCDA power supplies, GCSC, some communications

equipment, telemetry components, and some science equipment. This current is less than the RTG output and permits battery recharging. The line at the top of the figure indicates total battery state-of-charge (SOC) and decreases when batteries are discharged during peak load periods and increases during charge periods. Battery full charge level is indicated when the SOC line reaches and maintains 1060 W-hr.

All power subsystem operation during the primary landed missions was completely nominal and no anomalies occurred.

E. THERMAL SUBSYSTEM

The thermal subsystems on both Landers maintained the Lander hardware within the design temperature ranges during landed operations and no anomalies were observed. The ground software thermal model (LTEMP) adequately supported the landed mission, allowing identification of operating constraints and validation of proposed landed sequences from a thermal viewpoint.

The telemetry data indicated that the equipment plate temperature was generally controlled between 45 to 75°F for Lander 1 and 50 to 75°F for Lander 2. Some isolated temperatures were cooler (32°F minimum at camera 2 mast penetration) and some were warmer (TWTA interface with equipment plate approached 105°F at the end of direct links) due to localized cooling and heating effects. The Lander exterior temperatures were well within the design limits of the externally mounted components.

The Lander 1 external environment warmed about 7°F throughout the primary mission and internal temperatures also rose slightly during this time. The Lander 2 external environment cooled about 15°F with a corresponding reduction noted on Lander 2 internal temperatures. The thermal response of the two Landers was quite similar. In the early sols of the mission, Lander 2 was about 5°F warmer than Lander 1 because of longer solar exposure at the more northerly latitude. As the Lander 2 environment cooled, the Lander 2 temperatures became slightly cooler than those on Lander 1. Because of longer days and shorter nights at the Lander 2 site, the diurnal temperature variations on Lander 2 were typically smaller than those on Lander 1. The Lander 1 and 2 daily temperature ranges are shown in Figures VI-12 and VI-13.

During the first several sols, Lander and Orbiter surface temperature data and Lander imaging data were analyzed. This analysis indicated that the environment was slightly cooler than expected, but the Lander internal temperatures were relatively warm. To account for this apparent paradox, two important conclusions were drawn:

- 1) The Lander surface was dust covered, thus increasing solar absorptivity from 0.45 to 0.85. A very thin layer of dust can cause this significant change. Images showed dust on the magnet array, and the Lander surfaces eventually showed a well-defined reddish tint.
- 2) The effective radiation sky temperature was about 70°F more than originally assumed. This appeared reasonable since the imaging data showed a very bright sky due to scattering of light by a considerable amount of dust particles in the atmosphere.

Using the above data, measured meteorological data, and slightly revised Lander thermal component performance, LTEMP was adjusted and provided a "correlated" model for subsequent use. This model generally agreed within $\pm 5^\circ\text{F}$ of actual Lander temperatures. Typical results of this model are compared to measured values in Figures VI-14 through VI-16.

Since the Landers arrived at Mars during the Martian summer months, the environment was not cool enough to cause thermal switch activity. This is completely normal since the switches do not operate until the temperature of the equipment plate near the actuators reaches approximately 38°F. During the primary mission, the minimum temperature at the actuators was 50°F. As the Landers cool in response to the decreasing winter temperatures, the thermal switches will begin to supply surplus RTG heat to the equipment plate.

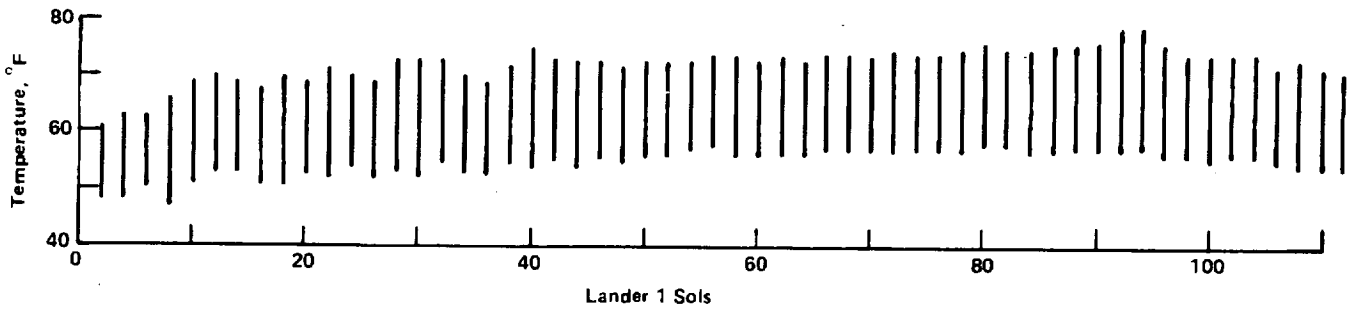

Figure VI-12 Lander 1 Primary Mission Internal Temperature Ranges

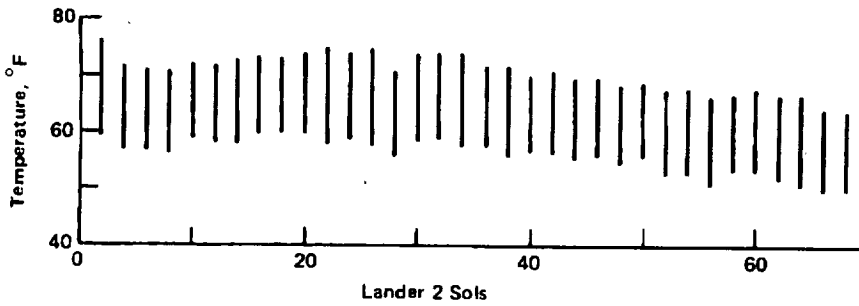

Figure VI-13 Lander 2 Primary Mission Internal Temperature Ranges

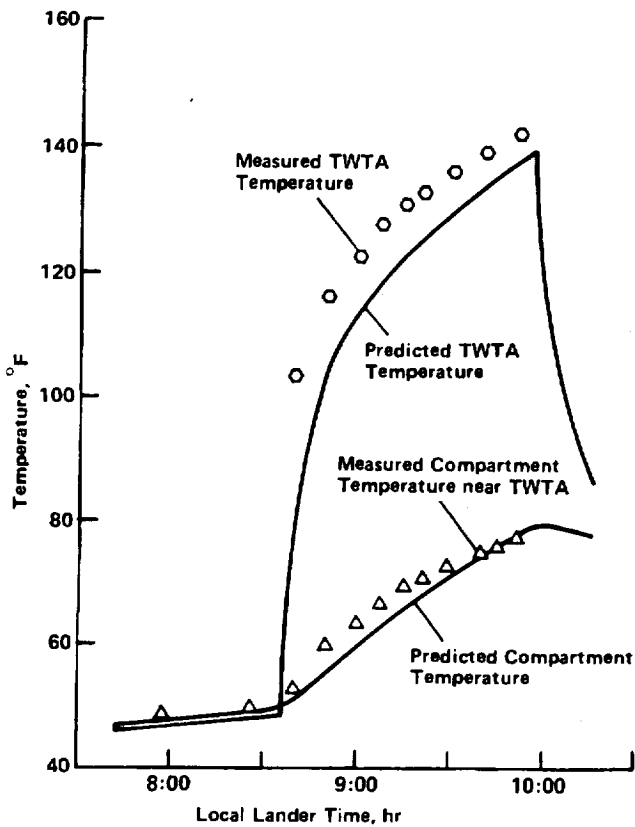

Figure VI-14 Landed TWTA Temperatures

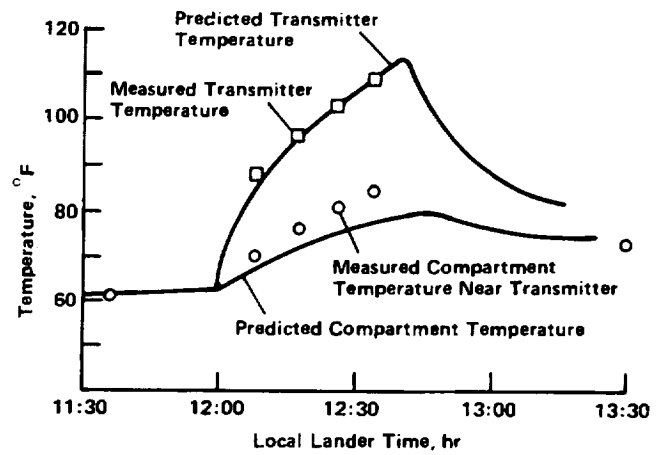

Figure VI-15 Landed UHF Transmitter Temperatures

F. SCIENCE SUBSYSTEM

This section describes the performance of the science hardware during the primary landed mission.

1. Biology

The objective of the biology instrument was to analyze samples of Martian surface material for evidence of living organisms. The biology instrument was unique among the Lander science instruments in that it consisted of three separate and very nearly independent experiments each of which sought to find evidence of living organisms by a different technique. The biology instrument was the single most complicated science instrument on the Lander and performed a total of 21 analysis cycles in all three experiments on both Landers. Tables VI-3 and VI-4 summarize the biology activities up to solar conjunction for Landers 1 and 2, respectively.

The performance of the biology instrument was superb. There was no significant malfunction of the hardware on either Lander and no science data were lost. All commands sent to the biology instrument were received and executed as planned. In conducting the sequences listed in Tables VI-3 and VI-4, the instrument performed the following activities:

- 1) Pyrolytic release experiment consisted of 480 hr of xenon lamp operation on Lander 1 and 20 hr on Lander 2, four gas injections on Lander 1 and three on Lander 2, and one water vapor injection on Lander 2;
- 2) Labeled release experiment consisted of seven nutrient injections on Lander 1 and six on Lander 2;
- 3) Gas exchange experiment consisted of 38 gas analyses on Lander 1 and 33 on Lander 2, four nutrient injections on Lander 1 and three on Lander 2, and termination of one soil analysis and initiation of a second on a fresh soil sample in the same test cell on Lander 2.

Two minor anomalies occurred. Both were in the pyrolytic release experiment. On Lander 1, in the second soil analysis cycle (control), noise spikes occurred in the carbon-14 detector data after that detector had been heated to 90°C in the first peak clean-up operation. The number of counting periods containing noise decreased as

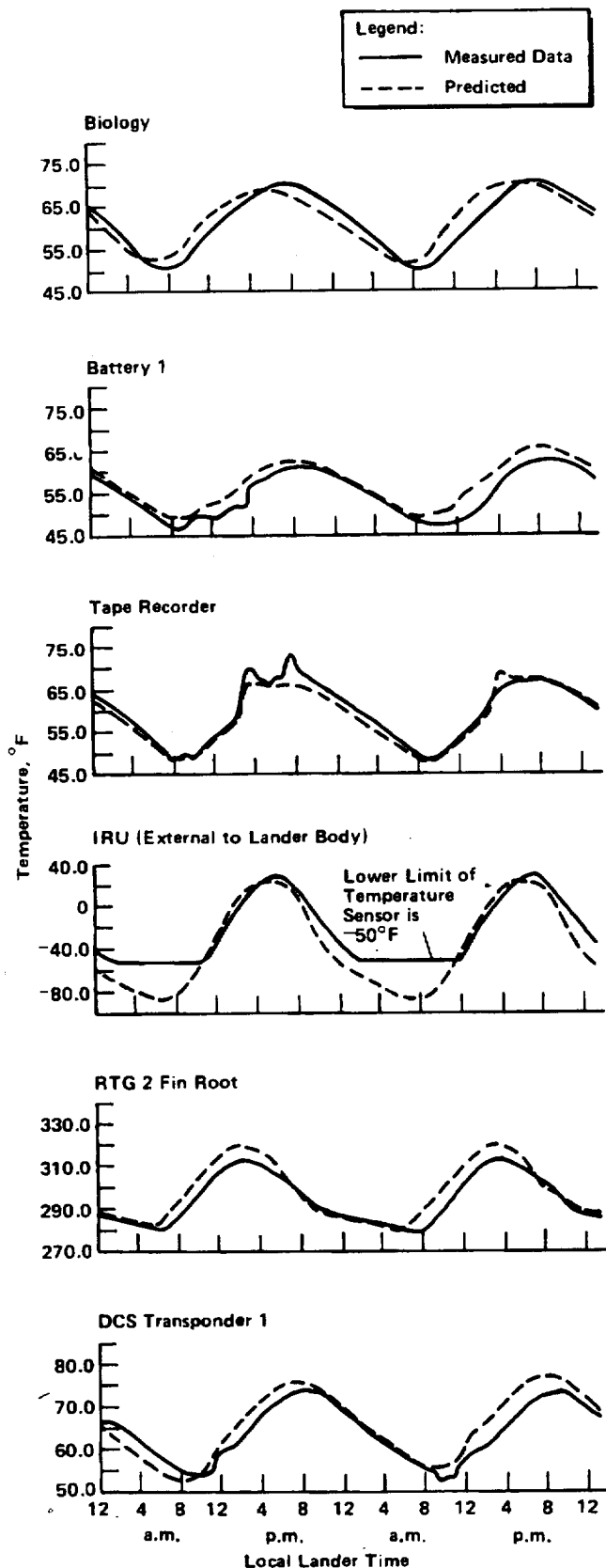

Figure VI-16 Typical Landed Temperature Profiles

Table VI-3 Lander 1 Biology Activities

Sequence	Sol on Which Initiated	Performance
Pyrolytic Release light, dry, active	8	Successful
Labeled Release active, 2 nutrient injections	8	Successful
Gas Exchange - 89 Sols active, 3 recycle operations, 38 gas analyses	8	Successful
Pyrolytic Release light, dry, control	27	Successful*
Labeled Release control, 2 nutrient injections	27	Successful
Pyrolytic Release light, dry, active	36	Successful
Labeled Release long active, 3 nutrient injections	39	Successful
Pyrolytic Release light, dry, active	91	Successful
*See text discussion of the detector noise that appeared here but did not alter the validity of the science data.		

Table VI-4 Lander 2 Biology Activities

Sequence	Sol on Which Initiated	Performance
Pyrolytic Release dark, dry, active	8	Successful*
Labeled Release active, 2 nutrient injections	8	Successful
Gas Exchange - 42 Sols active, 1 recycle operation, 21 gas analyses	8	Successful
Pyrolytic Release light, wet, active	28	Successful
Labeled Release 50°C control, 2 nutrient injections	28	Successful†
Pyrolytic Release dark, dry, active, subrock soil	51	Successful
Labeled Release active, subrock soil	51	Successful
Gas Exchange - 12 Sols active, no recycle operations, 7 gas analyses	51	Successful
*See text for discussion of detector leak which did not alter validity of science data.		
†See text for discussion of unusual results whose cause is unexplained.		

time went on, which indicated a recovery from the apparent heat-caused change. Counting of the second peak was extended to 4 sols compared to a minimum requirement of 12 hr counting time. The second peak data could reliably be recovered from the extended counting period by discarding count periods having anomalously high values.

On Lander 2 a slow leak in the pyrolytic release carbon-14 detector was observed during analysis of the data from the first soil analysis cycle. The leak did not change significantly throughout the primary mission and some sequencing changes were made in the counting regimes to permit a better correction of the data for the leak. The science data were not invalidated by the leak, but the absolute carbon-14 levels were determined with lesser confidence due to the corrections that were calculated and applied to the data.

One potential anomaly did occur on Lander 2 where the science data were unusual and difficult to explain. Unlike the data acquired from other labeled release analyses, the data obtained during the 50°C sterilization analysis showed unexpected and, to date, uninterpretable kinetics. Large percentage fluctuations in the carbon-14 level observed by the detector occurred on a cycle that seemed primarily to be diurnal. Such behavior had never been observed in all testing of the experiment on Earth. An engineering investigation was conducted to determine whether an instrument malfunction could account for the results. The investigation uncovered no instrument malfunctions and at this time cause of the unusual behavior remains undefined. A repeat of the 50°C control is planned for the extended mission to remove the uncertainty from the data interpretation.

2. Gas Chromatograph Mass Spectrometer (GCMS)

This subsection summarizes GCMS performance during the Viking primary mission (Lander 1 sols 0 through 108; Lander 2 sols 0 through 61). Objectives of the GCMS experiment were to analyze the atmosphere for vapor constituents and analyze the soil for organic materials. In terms of instrument performance, qualitatively and quantitatively, both objectives were met. In relationship to the GCMS instrument specification, nearly every performance criterion was exceeded, in some cases by factors as great as 100.

During the GCMS cruise activities it was concluded that oven 3 on Lander 1 and oven 1 on Lander 2 would not heat, and that the carriage position strobe signal was lost on Lander 2 (refer to Chapter III, Section D). The loss of the two ovens limited the number of soil samples to two per Lander in the primary mission. The loss of the strobe was not a detriment to instrument performance.

The major GCMS primary mission activities consisted of a total of 39 atmospheric samplings (24 on Lander 1) and multiple analyses of four soil samples (two soil samples per Lander). A column conditioning sequence was run on each Lander prior to the first soil sample to further clean the chromatographic system and establish an instrument background level. The objectives of the Lander 1 and Lander 2 activities were the same in that atmosphere and soil were analyzed, yet different in that the sequences run on Lander 2 were based on data from Lander 1. Scientific discoveries of the two missions are given in *Science* 193, p 801; 194, p 72 and 76, and p 1293. This subsection discusses hardware performance during the atmospheric and soil analyses. These sequences are grouped by type of analysis to simplify presentation and are as follows:

- 1) Atmospheric Analysis-Unfiltered (AA-U)—This sequence required two commands, one to admit a sample to the GCMS atmospheric inlet assembly, and one to admit a sample from the inlet assembly into the mass spectrometer, where the sample is analyzed. Sample analysis consisted of scanning the mass spectrometer background before the sample was admitted (four scans), then scanning the sample after admission (four scans).
- 2) Atmospheric Analysis-Filtered (AA-F)—In this sequence, a total of five commands were issued to the GCMS; three of the five were used to admit atmosphere, remove carbon monoxide (CO) and carbon dioxide (CO₂), and remove water. The remaining two commands were used to analyze the sample as in the unfiltered analysis; however, the background from the second analysis was not returned to Earth. Thus, a filtered analysis consists of a total of 12 scans.
- 3) Atmospheric Enrichment (AE)—The enrichment process involved repetition of the sequences which admit the sample, remove CO/CO₂, and remove water. This cycle can be repeated up to 15 times (based on commands), and was used to concentrate, in the inlet system, those constituents that were not removed by the filtering process. Upon completion of the enriching process, the sample was analyzed in a manner identical to that in the filtered analysis (a total of 12 scans).
- 4) Column Conditioning—In this sequence, portions of the instrument that were required to be hot during an organic analysis (valves, tubes, separator, column, and ion source) were heated. While these assemblies were hot, hydrogen flowed through the system, and purged out contaminants. Mass spectra were taken periodically to record the instrument background.
- 5) Soil Analysis—In this sequence up to nine commands were issued to the GCMS. The first seven commands were used to preheat the oven, place it in position for soil load, load the oven, move to the analyze position, and seal the oven into the flow path of the chromatograph. The final two commands of the nine were used to perform the actual sample analysis (OA). Several major variables permitted optimization of the soil analysis; among these were oven temperature, choice of labeled CO₂ oven purge gas, effluent divider control mode, and duration of column high temperature isothermal hold. Nominally, an analysis sequence returned 411 scans.
- 6) Bakeout—Several types of bakeout sequences were used to heat selected portions of the instrument to rid it of backgrounds.

Tables VI-5 and VI-6 summarize the sequences that were run on each GCMS instrument. All sequences ran nominally with three exceptions. During an atmospheric analysis on Lander 1 (sol 5/01:00:00) and an organic analysis on Lander 2 (sol 61/02:56:00), the GCMS experienced a voltage transient and returned to the standby mode. In this situation the instrument terminated mass scan data, issued no commands, and transmitted engineering data. In both cases, no instrument problems occurred as a result of this anomaly and subsequent GCMS sequences performed nominally without the need for special commands. When the atmosphere was sampled on sol 102 (Lander 1) the ion pump current rose to 532 μ A, indicating that the pump was showing signs of degradation due to argon exposure. This degradation has been taken into account in planning the extended mission for Lander 1.

Table VI-5 Lander 1 GCMS Activities

Sequence	Sol/ hr:min	Performance
AA-F	4/18:12	Nominal
AA-F	4/22:31	Nominal
AA-F	5/01:00	Return to Standby Mode
AA-F	5/04:06	Nominal
AA-U	5/11:00	Nominal
AA-U	5/18:21	Nominal
Column Conditioning	6/02:00	Nominal
Preheat/Unseal/Index	8/06:18	Nominal (OA precursor)
Load/Unseal/Index/Seal	8/06:24	Nominal (OA precursor)
No-Op (Preheat)	14/6:00	Nominal (OA precursor)
Load/Unseal/Index/Seal	14/7:18	Nominal (OA precursor)
No-Op (Preheat)	17/6:30	Nominal (OA precursor)
Load/Unseal/Index/Seal	17/7:00	Nominal (OA precursor)
OA-Hydrous-Short	17/11:45	Nominal
AA-U	17/18:12	Nominal
AA-U	17/19:40	Nominal
AA-U	17/22:32	Nominal
AA-U	18/01:00	Nominal
AA-U	18/2:28	Nominal
AA-U	18/4:06	Nominal
AA-U	18/10:30	Nominal
OA-Anhydrous-Medium	23/6:30	Nominal
AE-10x	24/17:30	Nominal
AE-10x	27/16:10	Nominal
Dump/Unseal	31/10:10	Nominal
Preheat/Unseal/Index	31/10:27	Nominal (OA precursor)
Load/Unseal/Index/Seal	31/12:35	Nominal (OA precursor)
OA-Hydrous-Long	32/4:35	Nominal
AE-10x	33/16:50	Nominal
OA-Hydrous-Long	37/5:00	Nominal
AA-U	41/20:40	Nominal
AA-U	42/06:00	Nominal
OA-Hydrous-Long	43/07:00	Nominal
AA-U	52/05:30	Nominal
AA-U	62/06:30	Nominal
AA-U	72/05:30	Nominal
AA-U	82/06:30	Nominal
AA-U	92/05:30	Nominal
AA-U	102/06:30	High ion pump current

Table VI-6 Lander 2 GCMS Activities

Sequence	Sol/ hr:min	Performance
Open Seal Clamp/Index to Position 1	1/7:30	Nominal (OA precursor)
Index to Position 4	1/7:38	Nominal (OA precursor)
Load	1/8:40	Nominal (OA precursor)
AA-F	3/14:54	Nominal
AA-F	3/18:48	Nominal
AA-F	4/2:00	Nominal
AA-F	4/5:12	Nominal
AE-5x	4/14:02	Nominal
AE-10x	5/14:30	Nominal
AE-10x	8/18:00	Nominal
AA-U	9/13:40	Nominal
AA-U	9/15:05	Nominal
Preheat	9/16:30	Nominal (OA precursor)
Column Conditioning		Nominal
Load/Unseal/Index/Seal	10/8:00	Nominal (OA precursor)
AE-15x	15/19:25	Nominal
AE-15x	16/6:12	Nominal
Load/Unseal/Index/Seal	21/11:46	Nominal (OA precursor)
No-Op	22/	Nominal (OA precursor)
OA-Hydrous-Medium	24/3:22	Nominal
OA-Hydrous-Medium	26/3:30	Nominal
No-Op/No-Op	35/3:14	Nominal (OA precursor)
OA-Hydrous-Medium	35/3:30	Nominal
OA-Hydrous-Medium	37/3:30	Nominal
Dump/Unseal/Index to Position 1	37/5:35	Nominal (OA precursor)
Index to Position 6	37/5:50	Nominal (OA precursor)
No-Op	37/6:04	Nominal (OA precursor)
Preheat	40/13:15	Nominal (OA precursor)
Load/Unseal/Index/Seal	40/16:30	Nominal (OA precursor)
OA-Anhydrous-Medium	41/04:00	Nominal
OA-Hydrous-Medium	43/04:00	Nominal
No-Op/No-Op	45/3:43	Nominal (OA precursor)
OA-Hydrous-Medium	45/04:00	Nominal
OA-Hydrous-Medium	47/04:00	Nominal
Bakeout C1 II	48/03:00	Nominal
Bakeout C1 I	50/03:00	Nominal
AE-15x	52/20:00	Nominal
AE-15x	53/09:00	Nominal
AE-15x	57/16:50	Nominal
AE-15x	61/0:30	Nominal
No-Op/No-Op	61/2:48	Nominal (OA precursor)
OA-Hydrous-Medium	61/2:56	Return to standby Mode
Open V 10	61/5:10	Nominal

3. X-Ray Fluorescence Spectrometer (XRFS)

Lander 1—Table VI-7 summarizes the operation of the XRFS and its performance during the Lander 1 primary mission and reduced mission. All data were taken at nominal voltages throughout the mission except for PC-3. PC-3's bias was lowered 50 volts for use in studying density of samples. This change was made on sol 26.

The first landed data showed that the gain of the proportional counters had returned to their flight acceptance test level. During the mission, the proportional counter gains did not vary significantly. The temperature coefficient of the proportional counter sections appeared to be no greater than that originally designed and tested.

Over the duration of the mission, PC-1 gain increased approximately 2% with 2% "normal" variation. "Normal" variation is caused by temperature, statistical variation due to short count periods, start up drift, and aging phenomena. PC-2 gain was stable within 1% with 3% "normal" variation. PC-3 gain was stable within 1% with approximately 4% "normal" variation. PC-4 gain was also stable within 1% with approximately 1.2% "normal" variation. Total operating time for sols 0 through 103 was 903.16 hr. The dump solenoid was operated 19 cycles of 61 sec at 4 Hz each. The flag solenoid was operated 18 cycles for a total time of 12.5 hr.

Lander 2—Table VI-8 summarizes the XRFS operation and performance during the Lander 2 primary mission. Instrument operation was nominal with one exception. The first landed data (calibration sol 0) showed a small number of noise counts in channels 0 through 24. During the execution of the last command of the sol 0 calibration sequence, extra counts were evidenced in the data. Detailed review of all the data from the sol 0 calibration showed that most all commands in the sequence collected data that contained counts not within the normal distribution limits expected. Analysis of the data showed that the noise in the XRFS data correlated to specific Lander events and the seismometer high data mode caused more counts to occur. Subsequent analysis of the data from a sol 27 "quiet period" test sequence run on Lander 2 showed that any GCSC activity caused noise in the data of the lower channels (channels 0 through 24) of the XRFS. GCSC activity which commanded DAPU activity increased the level of extra counts. Circuit and laboratory analysis

Table VI-7 Lander 1 XRFS Operation and Performance

Sol	XRFS Operation	Performance
0	Initial calibration sequence	Successful
8/9 thru 23/24	Analyses of first sample	Successful
25/26	Analysis of first sample, calibration flag raised	Successful
26/27	Analysis of first sample, lower PC-3 voltage	Successful
27/28 thru 30/31	Analyses of first sample	Successful
31/32 thru 33/34	Calibration/dump sequences	Successful
34/35	Analysis of second sample	Successful
35/36	Analysis of second sample	Successful
36/37 thru 39/40	Calibration/dump sequences	Successful
40/41 thru 59/60	Analyses of third sample	Successful
61 thru 65	Calibration/dump sequences	Successful
66 thru 71, 76, 78, 80, 83, 87, 90, 91, 96, 98, 100, 103	Analyses of dump residue	Successful

Table VI-8 Lander 2 XRFS Operation and Performance

Sol	XRFS Operation	Performance
0	Calibration	Normal except for noise in PC-1 and possibly PC-2 & 4
10/11	Analysis, no sample	Gain stable; noise in PC-1, 2, 4—715 V run on PC-1, 2 show noise in channel 0—24
14/15	Analysis of first sample*	Gain nominal; 715 V run on PC-3 shows noise in channel 0—21
16/17	Analysis of first sample	Noise to channel 23
17	Analysis of first sample	Noise to channel 24
27	Test sequence	715 V analysis
28/29	Calibration sequence	Noise effect minimized by gain increase
29/30 thru 41/42	Analyses of second sample	Successful
42/43 thru 44	Calibration/dump sequences	Successful
45/46	Calibration/dump and calibration	Successful
46/47 thru 51/52	Analyses of third sample*	Insufficient sample
56/57 thru 59/60	Analyses of fourth sample*	Insufficient sample

* Attempt was made to deliver small rocks to the XRFS; however the selected sample sites did not apparently yield rocks.

showed that increased noise currents in the Lander equipment plate can cause noise to be induced in the proportion counter tube/charge amplifier circuit of the XRFS. Failure of filter components or bypass components creates a very high noise level in these circuits, resulting in a high count rate unlike that created by the Lander 2 noise. The conclusion was that a change in a Lander component isolation impedance was causing an abnormally high current to flow in the Lander equipment plate when the GCSC or DAPU was powered up or down. This high current was sensed by the XRFS and counted in its lower channels. The affect of these extra counts was minimized by increasing the gain of the PC tube to effectively place the important peaks out of the low channels. The noise did not degrade the science information significantly. The proportional counters, gain of each proportional counter section, and temperature coefficients performed similarly to the Lander 1 XRFS (refer to Lander 1 discussion). Data for the landed operations showed PC-1 gain stable within 1% over this period with "normal" variations of approximately 3%. Data from PC-2 showed gain stable to 1% with "normal" variation of less than 1.5%. Data for PC-3 (also used at low gain for density analysis) showed 1% stable gain with 4.5% "normal" variation. Data for PC-4 also showed gain stability better than 1% and "normal" variation of approximately 1.5%. Total operating time for the primary mission was 357.72 hr. The dump solenoid was operated through seven cycles of 61 sec at 4 Hz each. The flag solenoid was operated one time for a total time of 0.64 hr.

4. Lander Camera System

The Lander cameras were operated throughout the Lander 1 and Lander 2 primary missions and the Lander 1 reduced mission. A total of 450 pictures were taken by Lander 1 and 580 by Lander 2. These pictures included:

- 1) Characterization of the surface structure at both Lander sites at various sun elevation angles in color, infrared, high resolution, and using various focus conditioning;
- 2) Complete panorama in high-resolution color, high-resolution black and white, and survey black and white for Lander 2;
- 3) Partial panorama in high-resolution color and complete panoramas in high-resolution black and white and survey black and white for Lander 1;

- 4) Characterization of the Martian surface and Lander surfaces photometrically on both Landers;
- 5) Characterization of the atmosphere with respect to particle sizes, densities, and vertical distribution;
- 6) Support of surface sampler activities and the Physical Properties and Magnetic Properties Investigations;
- 7) Monitoring of the surface with single line scans to observe particle motion;
- 8) Complete stereo in high resolution, color, and IR on both Landers;
- 9) Spectrophotometric study of the satellite Phobos;
- 10) Verification of the location of the surface sampler during anomalies;
- 11) Verification of high-gain antenna, meteorology boom, and processing and distribution assembly cover deployment and overall Lander condition after landing.

The number and quality of these pictures testifies to the outstanding performance of the Lander cameras. Further details of the Lander camera performance are discussed in the following paragraphs.

Lander 1—Camera parameters monitored for general health and life included: scan verification and dust coverage of the windows, internal calibration of the photosensor array output and temperature, and elevation motor scan cycles. Table VI-9 summarizes the scan verification and dust sequences on Lander 1.

Table VI-9 Lander 1 Camera Scan Verification and Dust Sequences

Camera 1 Cycles		Camera 2 Cycles	
Sol	Event	Sol	Event
6	Dust	1	Dust
	Scan Verification	2	Dust
7	Dust	4	Dust
12	Dust	6	Scan Verification
13	Dust		Dust
27	Dust		Scan Verification
	Scan Verification	7	Dust
51	Dust	11	Scan Verification
	Scan Verification		Dust
71	Scan Verification		Scan Verification
	Dust	27	Scan Verification
	Scan Verification	51	Scan Verification
91	Scan Verification		Dust
	Dust		Scan Verification
	Scan Verification	71	Scan Verification
			Dust
			Scan Verification
		91	Scan Verification

Scan verification is accomplished by imaging two small tungsten light bulbs on the inside of the camera stow post. The resulting image is out of focus, but it provides useful information about the camera's optical system and about the azimuth and elevation servo performance. Changes of a few percent in the transmittance of the outer window integrated over a circle 0.95 cm in diameter, caused by deposits on the window, should be observable. The outer window was dusted by spraying it with CO₂ gas under pressure for 200 msec from a nozzle attached to the camera stow post. Data from the scan verification images showed no significant changes during the primary mission from pre-separation checkout. Visual inspection of the images indicated no deviations from nominal scan servo performance. The scan verification dust-scan verification sequences showed that dusting the window did not significantly change the window transmittance. The absence of any apparent trend over the period from sol 1 through sol 91 indicated that there was no long-term dust accumulation on, or abrasion of, the camera windows during that period within the sensitivity of the test. The data also indicated that the images had not shifted. In conclusion, the scan verification images identified no camera anomalies. No dust accumulation was seen since landing, and the window duster did not affect window transmittance.

Internal calibrations performed on both cameras indicated no reduction in sensitivity of the diodes since pre-separation checkout. This was due primarily to the relatively short time span between landing and conjunction. Camera operation during the extended mission is expected to show a continuation of the diode degradation from neutron radiation from the RTGs.

The lifetime limiting device in the cameras is considered to be the elevation scan motors. Table VI-10 shows less than 17% of the specified life scan cycles have been accumulated totally from all camera operations up to conjunction.

The CO₂ duster was operated eight times up to conjunction with approximately 190 additional operations available (the amount of remaining CO₂ is not measured).

Lander 2—Due to the performance of the Lander 1 cameras, no scan verification sequences were performed on the Lander 2 cameras and minimum dust sequences were performed. Internal calibration data were consistent with the Lander 1

Table VI-10 Lander Camera Elevation Scan Cycles

	Lander 1		Lander 2	
	Camera 1	Camera 2	Camera 1	Camera 2
Vendor Test	294,340	294,340	294,340	294,340
Martin Marietta Lander Test	134,746	184,371	120,006	126,819
Total Prelaunch Scans	429,086	478,711	414,346	421,159
Preseparation Checkout	100	100	100	100
Postlanded Images	151,807	144,508	244,319	206,555
Total Scan Cycles (up to conjunction)	580,993	623,319	658,765	627,814
Percent of 3.8 x 10 ⁶ Cycles*	15.3%	16.4%	17.3%	16.5%

*Design requirements are 3.8 x 10⁶ scan cycles.

camera data. Table VI-10 summarizes the camera elevation scan cycles for Lander 2. Less than 18% of the specified life scan cycles have been accumulated up to the conjunction time frame. The CO₂ duster has approximately 195 cycles available for use during the extended mission.

Summary—Throughout the camera operation on both Landers, no anomalies occurred. Highlights of the camera performance are as follows:

- 1) In viewing preselected stable points on the Lander body, there was no detectable change in camera position;
- 2) By using non-nominal commands, the elevation field of view was increased to 110 deg (approximately -65 deg to 44 deg) whereas the nominal requirement was 100 deg (-60 deg to 40 deg);
- 3) Azimuth field of view was restricted to 335 deg (nominal 342.5 deg) to avoid deployment of the contamination cover;
- 4) At the conclusion of the primary missions, all cameras were operating better than required by specifications;
- 5) The CO₂ duster reservoir is available for use during the extended mission with 95% or better of the original dusting capability remaining.

5. Meteorology

Lander 1—The meteorology instrument performed nominally until sol 46. Confidence in the temperature sensors and resulting measurements was dependent on two factors:

- 1) The differences between the thermocouple and reference sensors were small and were predictable from effects due to conduction and radiation;
- 2) A close correlation existed between the air temperature (calculated from the meteorology instrument data) and the ground temperature (measured by the instruments on the Orbiter). During nighttime, the air and ground temperatures were expected to coincide and they did. Confidence in wind data (speed and direction) was based on close agreement between wind speed and direction values as calculated independently by the quadrant sensor and hot film sensors.

On sol 46 the quadrant heater failed. The quadrant heater voltage (i.e., voltage drop across the heated post on the quadrant heater) went full scale, indicating an open connection to the heater power circuit. Intermittent operation of the quadrant heater continued for a few sols, at which time the circuit remained open. The failure was probably caused by the temperature surge during power on/off cycles. As a result, power has now been left on continuously. Software techniques were developed to compensate for this failure and wind data can be obtained.

Lander 2—The ambient temperature sensor exhibited the same non-nominal behavior noticed at KSC and during cruise. Software techniques were again developed to work around the anomaly. All other aspects of the instrument performance were nominal.

6. Seismometer

Lander 1—Two anomalies occurred relative to the seismometer on Lander 1. The first anomaly was detected when the data from the relay link on sol 1 were processed. It was clear that the seismometer had not been uncaged in any axis by its landed initialization sequence. Additional uncaging attempts were made on sol 3, on sol 7, and on sol 32 with no success.

The seismometer functioned normally in all other respects except for the second anomaly, which was detected when the data from the relay link on sol 6 were processed. All of the amplitude data written into the seismometer data stream were zero for the entire period between the sol 5 relay link and the sol 6 relay link. All other aspects of

seismometer operation and the other parameters written into the data stream appeared normal. This anomaly has not recurred.

An attempt was made during the failure analysis effort to find some common link between the two anomalies. However, nothing was identified and the two anomalies appear to be unrelated.

As a result of the uncaging anomaly, the Lander 1 seismometer was operated in a reduced mode throughout the primary mission. Approximately 500 buffer dumps/sol for 18 sols and 83 buffer dumps/sol for 25 sols were received. During the reduced mission, no seismology data were collected.

Uncaging Anomaly—It was concluded from the following evidence that the seismometer did not uncage during its landed initialization sequence:

- 1) Uncaging produces large transients due to the motions of the coils from their caged to normal operating positions. The instrument output is driven to saturation regardless of gain setting and no such transient was observed. The expected transients were characterized during ground tests conducted prior to landing when a seismometer was uncaged by the flight-type software.
- 2) Calibration pulses obtained before and after "uncaging" are identical when corrected to a common gain setting. This shows that the coils are not free to move.
- 3) The pin pullers did not fire at the time that uncaging was supposed to occur. This can be deduced both from the fact that no current flow was detected by the seismometer and that, even if the coils were to remain stuck in the caged position, the impulsive force generated by the pin retraction would result in a significant output from the seismometer.

It is possible that the failure to uncage at the correct time could have resulted from the seismometer uncaging erroneously at some time before landing and having the sensing coils damaged by the dynamic environments. A review was made of the sequences run at KSC and no inadvertant uncaging sequence appears to have been run. In addition, the flight software separation sequence was run on proof test capsule with an armed seismometer and the seismometer did not uncage during the sequence. A comparison was made between the Lander 1 GCSC memory (from a landed memory

readout) and the GCSC memory as used in prior verification tests. The comparison shows that there were no changes either in the program or in the data base for the landed initialization sequence and consequently the uncaging attempt should have been successful. It is clear from the seismometer data that electrical continuity exists through each of the coils and flexural pivots. Experience with the failure of the development unit in pyro shock testing, in which all six of the flexural pivots physically broke, indicates that the probability that all three of the sensing coils are sufficiently damaged to inhibit coil motion but not sufficiently damaged to break any flexure is very small. In addition, if a coil were resting against say a magnet face, some evidence of motion would be expected during periods of S-band antenna motion and surface sample acquisition. No such coil motion was observed. All evidence to date indicates that the coils are still firmly caged and that uncage current did not flow in the uncaging circuits.

The detailed designs for the seismometer and PCDA were reviewed but no circuit design problems or part overstress problems were identified. Since the uncaging anomaly cannot be explained by the failure of a single piece part and since no overstress condition exists that may result in multiple failures, failures of piece parts has been ruled out as the cause of the problem. The following potential single-point failures were identified:

- 1) Seismometer arming plug miswired;
- 2) Broken uncaging power return wire in the seismometer;
- 3) Broken uncaging power return wire in the Lander harness;
- 4) Broken uncaging power return wire in the PCDA;
- 5) Significant contact resistance or total lack of continuity in either connector carrying the uncaging power return wire.

The failure analysis indicated no systematic problem that could be related to Lander 2 and, in fact, the Lander 2 seismometer operated nominally as described later in this subsection.

Data Anomaly—No convincing explanation has been found for the data anomaly failure or why it is self correcting by power cycling the seismometer. It is highly coincidental that the same problem occurred on a development unit at the California Institute of Technology for the first and only

time two days before it occurred on the Lander 1 instrument for the first and only time. After the problem occurred on the development unit, the instrument was power cycled 16 times and then transferred to Denver where it was power cycled 99 times. The problem has not repeated. It is thought that there was a significant power line transient at the California Institute of Technology at about the time that the development unit started malfunctioning, but the indication of this is not conclusive. Since it is believed that system transients occur at the beginning of the relay link sequence on the Lander, it is possible that the problem may result from system transients, but no reasonable mechanism has been identified.

Lander 2—The seismometer on Lander 2 performed nominally at all times. After landing, but prior to uncaging, the seismometer was operated at maximum gain in each operating mode to provide basic instrument electronic noise information. The noise levels were low and compared well with similar data obtained before launch.

Following the completion of the electronics noise tests, the seismometer was uncaged with the instrument operating at minimum gain.

Each seismometer has a means of self calibration by forcing a displacement of each of its sensing coils. Lander 2 calibration pulses showed that the sensor coils were moving freely. The pulses were of the correct amplitude and an analysis of the calibration sequence provided an angle for Lander tilt which agreed well with other independent measurements. The calibration sequence was repeated on most days during the primary mission and showed good stability.

In view of the low amplitude of motion of the Lander, limited data were obtained at instrument gains other than maximum gain. However, all data to date indicate the gain changing is working correctly. The same comments apply to the instrument low pass filters.

The operation in the trigger enabled mode was used primarily during the conjunction period. The triggering function worked correctly.

In summary, all three operating modes of the seismometer on Lander 2 and all of the various operational parameters appeared to be working normally.

7. Surface Sampler

The purpose of the surface sampler was to acquire, process, and distribute samples from the Martian surface to the biology instrument, GCMS, and XRFs and to support the physical properties, magnetic properties, and meteorology investigations. During the course of the primary mission the surface sampler provided outstanding support to the instruments and investigations as indicated in the tabulation at the right.

Figures VI-17 and VI-18 illustrate the sampling areas for Landers 1 and 2, respectively, and summarize the surface sampler activities for both Landers.

Lander 1—Table VI-11 summarizes the surface sampler operations for Lander 1, giving time the sequence occurred, the sequence duration, number of commands issued, and the results. Twenty sequences were performed (including biology and GCMS PDA lid deployment). Of these, 17 sequences were successful, two resulted in a "no-go",

Lander 1	
Biology	Three samples.
GCMS	Two samples.
XRFs	Three samples.
Physical Properties	Trenches, boom mirror images of footpad 2 temperature sensor and terminal descent engine disturbance, comminutor and boom motor currents, collector head front porch image, sample on top of Lander, subsurface temperature measurements, and backhoe penetrations into the surface.
Magnetic Properties	Direct and magnifying mirror images of backhoe magnets.
Meteorology	Atmospheric temperature measurements.
Lander 2	
Biology	Three samples (one from under a rock).
GCMS	Two samples (one from under a rock).
XRFs	One sample (several attempts made unsuccessfully to obtain rocks).
Magnetic Properties	Direct and magnifying mirror images of backhoe magnets.
Physical Properties	Trenches, boom mirror images of footpad 2 temperature sensor and terminal descent engine disturbance, comminutor and boom motor current, and collector head front porch image, subsurface temperature measurements, rock excavations, and backhoe penetrations into the surface.
Meteorology	Atmospheric temperature measurements.

Table VI-11 Lander 1 Surface Sampler Performance Summary

Operation	Local Lander Time (LLT)	Universal Time Constant (GMT)	Duration, hr	No. of Commands	Results
Landing	0/16:13:12	202/11:53:06	—	—	Successful
Biology PDA Lid Deploy	0/16:19:08	202/11:59:02	—	—	Successful
Shroud Eject	2/10:20:50	204/07:19:54	0.25	13	Shroud ejected, latch pin jam, no-go
GCMS PDA Lid Deploy	3/14:00:00	205/11:38:39	—	—	Successful
Pin Jam Recovery	5/10:40:00	207/09:37:49	0.21	12	Successful
Biology Sampling	8/06:54:28	210/08:05:27	1.89	58	Successful
GCMS Sampling	8/08:52:50	210/10:03:49	1.15	76	Partial success—no sample "level full"
XRFs Sampling	8/10:35:50	210/11:49:49	0.72	38	Successful
XRFs Sampling	8/11:22:50	210/12:33:49	0.72	38	Successful
GCMS Sampling	14/06:25:00	216/11:19:07	0.28	13	Acquired sample, no delivery, no-go
Diagnostic Sequence	18/14:00:00	220/21:32:48	0.10	29	Successful
GCMS Sample Delivered	22/12:00:54	224/22:11:43	0.48	29	Successful
Dump GCMS Sample	31/10:00:00	234/02:07:06	0.07	11	Successful
GCMS Sampling	31/10:40:00	234/02:47:06	0.75	49	Successful
XRFs Sampling	34/10:10:00	237/04:15:52	0.66	41	Successful
XRFs Sampling	34/11:10:00	237/05:15:52	0.66	41	Successful
Biology Sampling	36/11:10:00	239/06:35:02	2.34	60	Successful
XRFs Sampling	40/10:27:50	243/08:31:13	0.95	47	Successful
XRFs Sampling	40/12:07:50	243/10:11:13	0.95	47	Successful
Physical/Magnetic Properties	41/15:30:00	244/14:12:58	0.97	40	Successful
Biology Sampling	91/07:00:00	295/14:42:21	1.92	61	Successful
Totals			15.07	703	

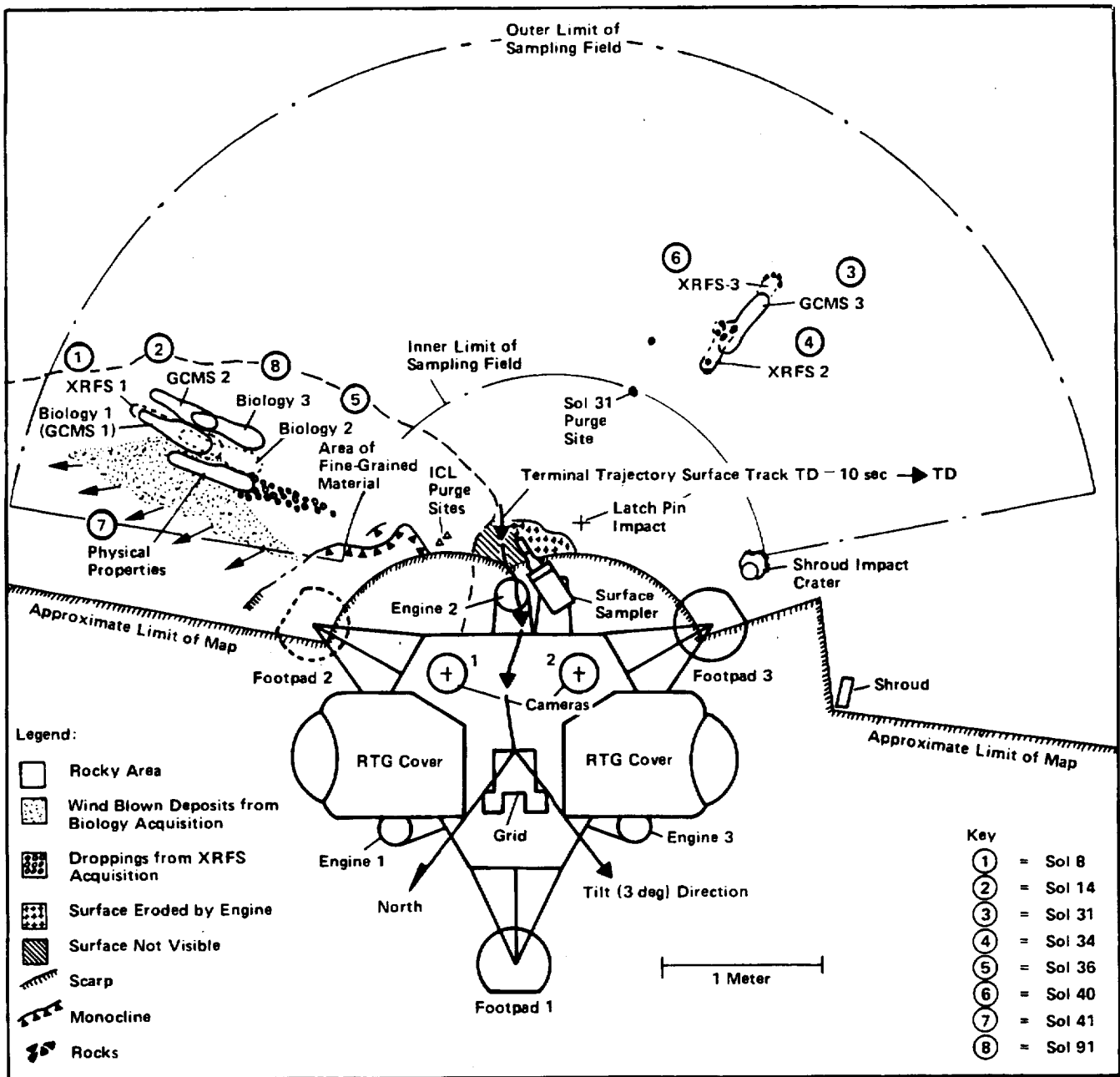

Figure VI-17 Schematic of Lander 1 Sampling Area Summarizing Nominal Mission Surface Sampler Activities

and one resulted in no sample “level full.” The three anomalies are described in the following paragraphs.

Shroud Eject, Latch Pin Jam—On sol 2 during execution of the 13th command (retract from 4.1 to 2.0 in.) the boom failed to attain position and a “no-go” was generated when the 14th command was issued. Subsequent analysis revealed that the launch and cruise boom restraint pin was jammed, and did not fall free from its guide during execution of the 6th command (extend from 2.3 to 6.0

in.). When the boom was commanded to retract during the 13th command, the unreleased latch pin misaligned and jammed against the boom pin support structure. A recovery sequence was performed on sol 5 which:

- 1) Reset the “no-go” flag;
- 2) Commanded the boom to an azimuth position of 186.6 deg and an elevation of 7.2 deg so that it would be possible to image the released restraint pin on the surface;

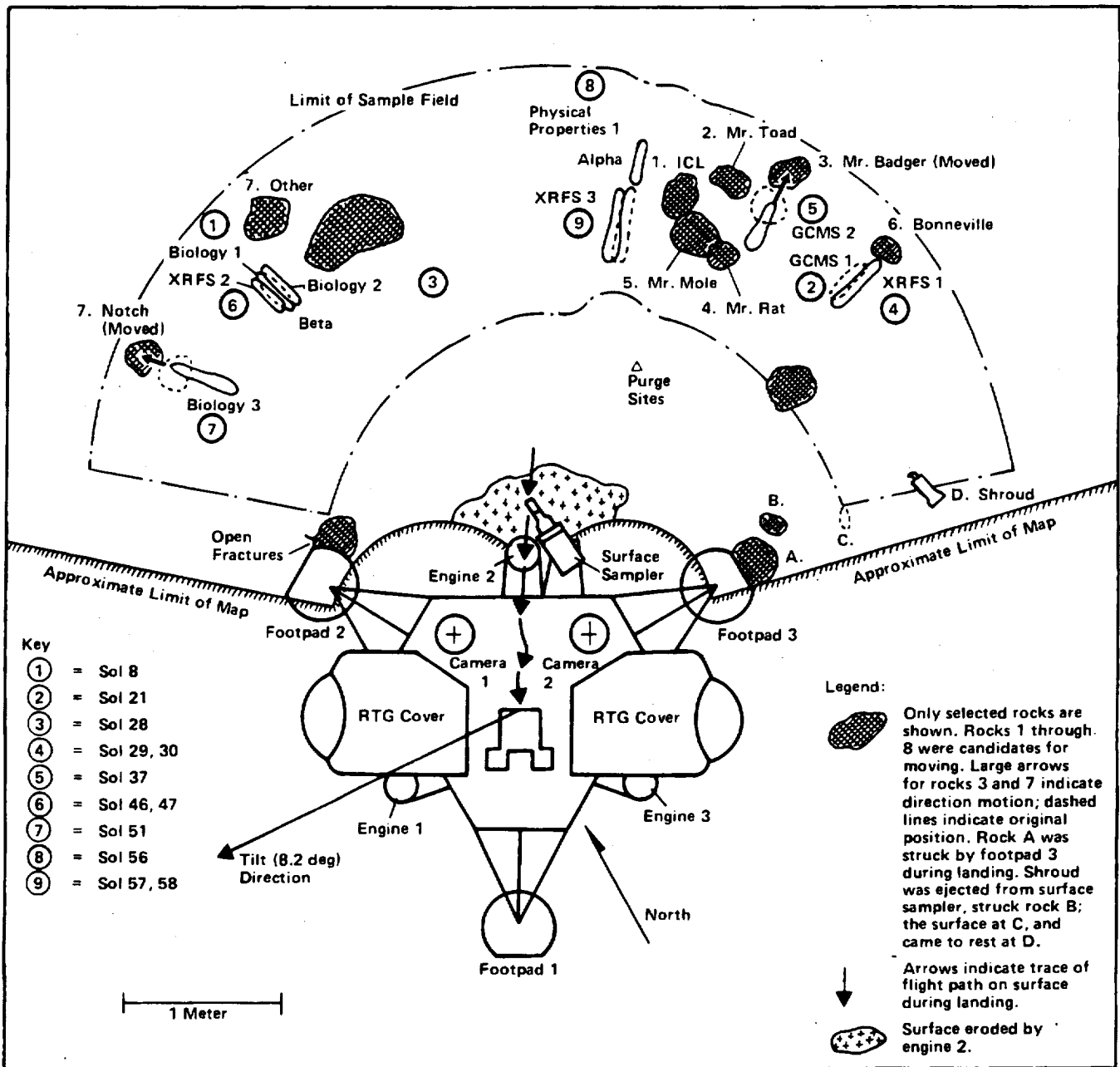

Figure VI-18 Schematic of Lander 2 Sampling Area Summarizing Nominal Mission Surface Sampler Activities

- 3) Extended the boom to 12.0 in. and vibrated the collector head at 4.4 Hz to provide vibration to assist the gravitational drop of the pin from its guide;
- 4) Repositioned the boom and acquired profile images of the boom collector head area and the surface to determine the location of the restraint pin.

The sequence was successfully executed on sol 5 with no anomalies encountered.

GCMS PDA Absence of Sample Level Detector Full Indication—On sol 8, a GCMS sampling sequence was initiated. All commands were successfully executed, but no sample level detector “full” indication was received during the first acquisition attempt. A second acquisition attempt commanded by the do-loop logic again resulted in no sample level detector “full” indication. The system completed its sequence in a normal manner and the boom was parked as planned. The following potential causes of the anomaly were considered:

- 1) Insufficient sample acquired in the collector head because of identical sampling location as that used for the previous biology sample.
- 2) Insufficient time allowed for the sample to pass from the GCMS PDA funnel, through the comminutor auger section, and through the 300-micron sieve into the metering cavity.
- 3) Auger stirring spring not contacting the 300-micron sieve.
- 4) Sample level detector circuit faulty.

Corrective actions were designed to correct for any of the four potential causes. A sol 14 sequence was designed to correct causes 1, 2, and 3 and included the following:

- 1) Revised sampling site coordinates to an undisturbed area;
- 2) Added a GCMS distributor vibrate command during the sample metering operation to assist the flow of material through the 300-micron sieve;
- 3) Increased the collector head vibrate time over the GCMS PDA from 17 to 30 sec;
- 4) Increased the comminutor time from 90 to 120 sec;
- 5) Increased the sample dump sieving time from 20 to 40 sec.

The sequence was initiated, and a sample acquired, however, a boom extend/retract problem (see below) resulted in a "no-go," which precluded delivery of the sample to the GCMS PDA. This problem was analyzed, corrected on sol 18, and a sol 22 sequence was planned to complete the delivery of the sol 14 sample. The original sol 8 GCMS sampling problem was further analyzed in the interim, and the following additional changes were implemented on a sol 21 uplink for the sol 22 delivery:

- 1) Increased the collector head vibration time over GCMS PDA from the previous revision of 30 sec to 45 sec;
- 2) Increased the comminution time from the previous revision of 120 to 140 sec, and added an additional 120-sec comminute cycle.

This recovery sequence was intended only to deliver the sample to the GCMS PDA. Delivery to the GCMS instrument was to be delayed until completion of the sol 22 data analysis.

The sol 22 sequence was executed properly with no anomalies encountered. A sample level detector full indication was attained during the first comminution cycle.

A parallel plan was also implemented to determine whether or not a sample was actually delivered to the GCMS instrument on sol 8 even though the GCMS PDA sample level detector had indicated a "no sample" condition. A GCMS analysis was conducted using the pyrolysis oven, which would have received any delivered sample. The analysis subsequently indicated that a sample had been delivered to the GCMS instrument on sol 8. This situation is possible, since the GCMS instrument requires less than 0.1 cc of sample for a reasonable analysis, whereas the GCMS PDA distributor requires approximately 0.7 cc of material in the metering tube before a sample level detector full indication is possible.

The Molecular Analysis Team decided against using the sample originally acquired on sol 14 and delivered to the GCMS PDA on sol 22. Adequacy of the sol 8 sample was eventually established on sol 23. Therefore, both the PDA and GCMS instrument loading hopper were purged of "Sandy Flats" sample material on sol 31. The normal GCMS surface sampler control assembly (SSCA) sampling tables were revised in accordance with the changes previously described, and a fresh sample was acquired from the "Rocky Flats" area on sol 31. This sequence was executed properly with no anomalies encountered. The Lander 2 GCMS sampling sequences were also subsequently revised in the same manner, and all GCMS sampling sequences on that Lander were successfully executed with no anomalies encountered.

Boom Retract Failure—On sol 14 a GCMS sampling sequence execution was initiated. Analysis of SSCA data indicated normal sequence performance through execution of the 12th command. During execution of the 13th command (boom retract to 10.5 in.), the commanded position was not attained, and when the GCSC issued the 14th command (GCMS PDA distributor counterclockwise), the SSCA "no-go" resulted in GCSC power down of SSCA.

Analysis of the SSCA data indicated proper responses to all commands through the 12th command. Examination of the sol 14 imagery revealed that the sampling trench was dug as expected, but

the collector head was not present over the GCMS PDA when expected. This was consistent with the SSCA data. A sol 15 image revealed the back side of the boom, indicating that it was generally in a position consistent with the sampling azimuth of 107.7 deg and the last executed command of +15.4 deg elevation.

The following potential causes of the anomaly were considered:

- 1) Failure of the SSCA power side 1 electronics;
- 2) Failure of the boom extend/retract motor, position feedback potentiometer, or interconnecting wiring;
- 3) Jamming of the boom precluding proper retraction.

Causes 1 and 2 were considered unlikely, because all functions had operated properly during execution of the first 12 commands. Jamming of the boom as it attempted to execute the retract command was considered to be the most likely cause of the problem, particularly because of its similarity to the problem on sol 2.

Frozen carbon dioxide or surface material were rejected as potential causes of jamming the boom mechanisms due to the absence of a slowly increasing motor load, which would have been revealed by the current measurements. Discussion of the anomaly with the boom designers revealed that a similar problem had occurred during early test phases of the boom. The problem was believed to be caused when a series of successive retract (or extend) commands are issued. The successive retract commands cause the boom element to become very tight on the storage drum. Additionally, the boom element tends to store in a five- to six-sided configuration (rather than perfect circular symmetry) on the drum, which causes intermittent high loading when the "points of the hexagon" pass under the boom restraint brake shoes. These two factors in combination can result in excessively high retract motor instantaneous starting torque requirements, which may be further increased when operating at low temperatures of -50 to -100°F to the level where the motor torque limiter decouples and movement of the boom ceases.

Two major operating procedures were incorporated to alleviate this potential anomaly:

- 1) All sequences were revised so that there were no successive extend or retract commands. This

precluded excessive tightening of the boom element on the drum, and the command reversals cause the extend/retract "flip-flop" gear to disengage the load during each cycle, which allows the motor to attain full speed and operating torque before re-engaging the load in the opposite direction.

- 2) Future operations were to be performed within 1 to 2 hr of the peak temperature during the Martian sol, which would result in most operations occurring above 0°F.

An uplink diagnostic sequence was designed for execution on sol 18. The sequence consisted primarily of operating the boom in each axis of operation (extend, retract, up elevation, down elevation, clockwise, and counterclockwise). Each movement was protected by close timing control and "no-go" inhibit sequences to preclude the generation of no-go's and subsequent termination. Successive extend or retract commands were eliminated.

The sequence was executed properly and no anomalies were encountered.

All subsequent Lander 1 and 2 sequences were redesigned: to exclude, wherever possible, successive extend or retract commands, and to perform these operations during the warmest part of the sol. No further problems were encountered on either Lander. Operating temperature restrictions were eventually waived because of the need to acquire early morning biology samples on both Landers. No problems were encountered during these low temperature operations.

Lander 2—Table VI-12 summarizes the surface sampler operation for Lander 2. A total of 28 sequences were performed (including biology and GCMS PDA lid deployment). Of these, 18 were successful, nine were partially successful because insufficient rock samples were delivered to XRFS, and one resulted in a "no-go." The insufficient samples for XRFS were not caused by hardware anomalies. (It is interesting to note that the Lander 2 boom extension/retraction cumulative total travel was greater than the length of a football field.) The one anomaly is described in the following paragraphs.

Collector Head Rotation Switch Failure—On sol 8 the biology sampling sequence execution was initiated. Analysis of the SSCA data indicated nor-

CA

Table VI-12 Lander 2 Surface Sampler Performance Summary

Operation	Local Lander Time (LLT)	Universal Time Constant (GMT)	Duration, hr	No. of Commands	Results
Landing	0/09:49:05	247/22:37:50	—	—	Successful
Biology PDA Lid Deploy	0/09:55:53	247/22:44:38	—	—	Successful
Shroud Eject	1/10:44:50	249/10:05:32	0.36	19	Successful
GCMS PDA Lid Deploy	3/14:00:00	251/14:39:53	—	—	Successful
Biology Sampling	8/16:00:00	256/10:05:27	1.66	50	Partial success; no-go before XRFS delivery
Collector Head Diagnostic Sequence	10/15:30:00	258/10:54:37	0.02	2	Successful
XRFS Delivery	13/16:45:00	261/14:08:22	0.06	8	Partial success; insufficient rocks
GCMS Sampling	21/10:00:00	269/12:40:04	1.06	67	Successful
Biology Sampling	28/16:00:00	276/23:17:11	1.95	64	Successful
XRFS Sampling	29/13:30:00	277/21:26:46	0.50	42	Successful
XRFS Sampling	30/10:30:00	278/19:06:22	0.50	42	Successful
GCMS Rock Nudge	30/11:20:00	278/19:56:22	0.37	19	Successful
GCMS Rock Push	34/10:35:00	282/21:49:43	0.36	23	Successful
GCMS Rock Push	37/10:00:00	285/23:13:28	0.17	18	Successful
GCMS Sampling	37/16:00:00	286/05:13:28	1.29	97	Successful
GCMS Sample Delivery	40/15:50:00	289/07:02:14	0.34	23	Successful
Biology Double Rock Nudge	45/10:00:00	294/04:30:10	0.49	36	Successful
XRFS Sampling	46/13:00:00	295/08:09:46	0.61	39	Partial success; insufficient rocks
XRFS Sampling	46/13:40:00	295/08:49:46	0.61	39	Partial success; insufficient rocks
XRFS Sampling	47/13:00:00	296/08:49:21	0.61	39	Partial success; insufficient rocks
XRFS Sampling	47/13:40:00	296/09:29:21	0.61	39	Partial success; insufficient rocks
Biology Rock Push	51/06:15:00	300/04:42:42	0.19	19	Successful
Biology Sampling	51/06:40:00	300/05:07:42	2.58	79	Successful
Physical/Magnetic Properties	56/14:00:00	305/15:45:38	1.24	59	Successful
Physical/Magnetic Properties	57/06:43:00	306/09:08:13	0.96	43	Successful
XRFS Sampling	57/08:00:00	306/10:25:13	0.45	39	Partial success; insufficient rocks
XRFS Sampling	57/08:45:00	306/11:10:13	0.45	39	Partial success; insufficient rocks
XRFS Sampling	58/08:00:00	307/11:04:49	0.45	39	Partial success; insufficient rocks
XRFS Sampling	58/08:45:00	307/11:49:49	0.45	39	Partial success; insufficient rocks
Total			18.34	1022	

mal sequence performance through execution of the 49th command. During execution of the 50th command (collector head rotate counterclockwise), there was no indication that the commanded rotational position was attained. When the GCSC issued the 51st command (extend to 8.4 in.), the SSCA "no-go" resulted in GCSC power down to the SSCA. Analysis of the SSCA data indicated proper response to all commands through the execution of the 49th command. However, a collector head rotation timing peculiarity was noted during the execution of the 40th command (collector head rotate clockwise).

The 7.56 sec required during execution of the 40th command was unquestionably excessive. It was believed that the cam actuated switch did not

operate properly at the 45-deg position, and the collector head continued its rotation to the incorrect backhoe down position, where the cam actuated switch did operate and a position achieved signal was generated. During execution of the 41st command, the collector head was already in the upright position. Therefore, the rotation motor clutched the collector head against its hardstop, and this vibratory action actuated the switch, which resulted in a position achieved indication.

The 50th command issued by the GCSC during this sequence was a collector head rotate counterclockwise to the 45-deg position. It was believed that the rotation switch did not operate at all during this command, and that the collector head rotated to the fully inverted position, clutched

against the hardstop, and an SSCA "no-go" was generated due to the absence of a position achieved indication.

A diagnostic sequence was uplinked to execute on sol 10 which reset the "no-go" flag and commanded the boom to extend to 16.2 in. (over the XRFS funnel) so that the collector head could be imaged. The sequence executed properly with no anomalies. Imaging data verified that the collector head was in the suspected fully inverted position.

An uplink sequence on sol 13 contained a "no-go" inhibit sequence and commanded the collector head to rotate clockwise for 10 sec. This sequence was intended to position the collector head in the upright position so that any residual sample could be delivered to the XRFS instrument. The sequence executed properly with no anomalies. Imagery verified that the collector head had rotated to the proper position.

All subsequent Lander 2 sequences were revised to use timed commands in conjunction with "no-go" inhibit sequences to preclude the need for the rotation cam actuated switch signal. No further problems were encountered on Lander 2 with the revised commanding technique.

The accumulated ground and mission operations time on all motors and solenoids were well within specified operating life times.

Summary—Performance of the surface sampler subsystem hardware was considered excellent during the primary mission, and sufficient reserve capability is available for performing the goals of the extended mission. Only three of the 1725 com-

mands issued by the GCSC resulted in the generation of an SSCA "no-go" with subsequent sequence termination. Of these three no-go's, one (Lander 1 boom launch restraint pin jam) was caused by a sequencing error, and one (Lander 1 boom retract failure) was caused by a lack of knowledge of the performance characteristics of the boom. The third "no-go" (Lander 2 collector head rotation switch failure), was probably caused by either a microswitch failure or a marginal adjustment of the cam-microswitch failure or a marginal adjustment of the cam-microswitch actuation system. The fourth anomaly (Lander 1 GCMS PDA absence of sample level detector full indication) was believed to be related to the unusually high cohesive nature of the Martian surface material rather than a hardware failure. Corrective actions or workaround sequences were designed for all of the anomalies encountered so that all operational requirements were met.

Additional operational requirements (or goals) were levied upon the surface sampler during performance of the primary mission. These included rock pushing sequences, and sequences to deliver pebbles and rocks (only) to the XRFS experiment. The rock pushing sequences were successful due to the design margin available in the boom extend/retract system. The pebbles and rocks delivery sequences were marginally acceptable during Lander 1 operations, but insufficient quantities of rocks were delivered during the Lander 2 attempts. This problem is believed to be partially caused by the lack of large quantities of small rocks in the Lander 2 sampling area. Additional sequences for attaining sufficient quantities of small rocks for the XRFS experiment will be executed during the extended mission.

VII. EXTENDED MISSION

- A. Scope
- B. Lander 1 Capabilities
- C. Lander 2 Capabilities

Photograph from Lander 1 taken on August 6, 1976, shows a miniature weather station atop the meteorology boom.

ORIGINAL PAGE IS
OF POOR QUALITY

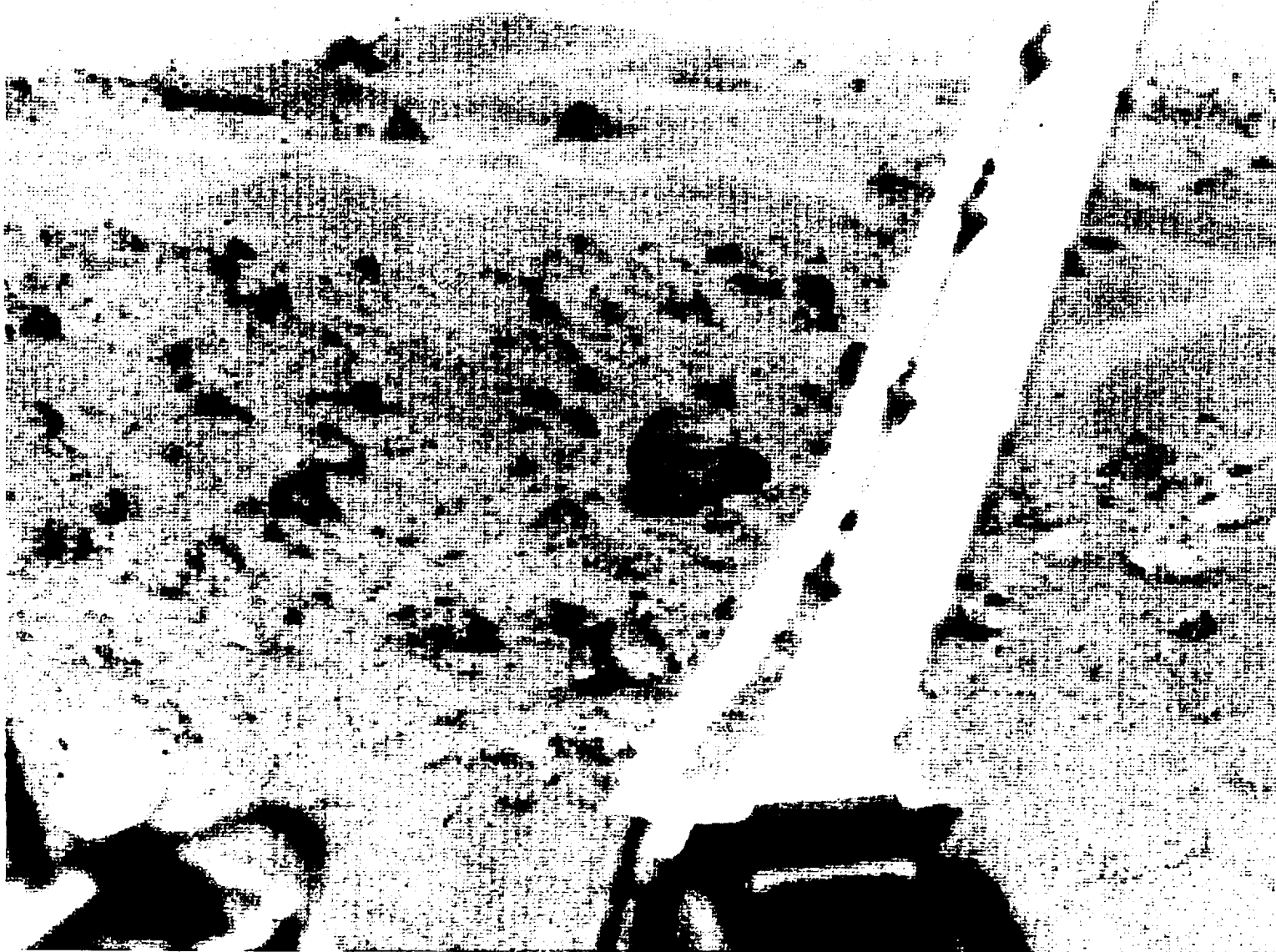

VII. EXTENDED MISSION

A. SCOPE

At the completion of the exceedingly productive and scientifically rewarding primary mission, both Landers continue to operate and support all science investigations, with the exception of the seismology experiment on Lander 1. In fact, both Landers contain redundant equipment that has not yet been operated during the landed missions. Some examples of this are: GCSC-B, DAPU-B, PCDA converter-B and SSCA-B. Because the Lander instruments and supporting engineering subsystems are in an operating mode and both Orbiters are operational, NASA has funded an extended mission encompassing the solar conjunction period and one Martian year from landing.

The objective of extending the Viking primary mission is to make use of these operational spacecraft to obtain seasonal variations, long-duration sampling for statistically important experiments, and to obtain data not possible during the primary mission due to time constraints or observational limitations. A complete Martian year (approximately twice an Earth year) of data, primarily meteorology and seismology, is planned. However, all Lander science investigations will be continued from the primary mission and every attempt will be made to achieve the objectives listed in the following paragraphs.

1. Biology

In the primary mission, sufficient time was available to conduct three analyses. The biology instrument has been built to permit four possible repeated analyses (three experimental sequences and one control). The extended mission presents an opportunity to provide a lengthy incubation period for possible organisms and perform the final analysis. On Lander 1, three samples for biology are planned, one from a deep hole and two from the surface. On Lander 2, two samples are planned, one from the surface and one from subsurface.

Labeled Release Experiment—Lander 1 will perform two experiment cycles on the surface sample and incubation will continue until March 1977. On Lander 2 the analysis on acquired soil beneath a rock will be completed and a new sample obtained repeating the 50°C control, "cold" incubation after nutrient injection.

Pyrolytic Release Experiment—There will be two experiment cycles performed by Lander 1: one on soil already in the instrument, and one on newly obtained surface soil. On Lander 2 three experiment cycles will be accomplished. There will be one on soil already in the instrument, one on newly obtained soil, and one "cold" incubation on newly acquired surface soil.

Gas Exchange Experiment—Lander 1 will complete a 200-sol incubation period on the soil obtained on sol 8. A soil chemistry (O₂ release) analysis will be conducted on soil obtained from the subsurface. Lander 2 will complete the incubation of soil obtained beneath a rock.

2. Meteorology

The meteorology investigation requires significant statistical data for interpretation. The seasonal coverage, coupled with supporting data from instruments on the Orbiters will probably permit global atmospheric modeling. An understanding of Martian weather is likely to emerge from seasonal variations of the diurnal cycle, pressure, and wind measured.

3. Seismology

The seismology investigation also requires significant statistical data because seismological events occur randomly. A major seismic event on Mars will permit the characterization of the core, mantle, and crust of which very little is known. This, in time, would reveal the thermal history of the planet. The extension of the Lander 2 operation increases the possibility of an event occurring during the investigation. Monitoring periods will be concentrated in the most quiet periods of the Martian day.

4. Molecular Analysis

Atmospheric Analysis (AA)—Seasonal or secular changes will be obtained to increase the knowledge of atmospheric dynamics. Periodic filtered and unfiltered atmospheric analyses will be conducted to detect trends and compositional changes at each landing site.

Atmospheric Enrichments—Periodic enrichments and analyses will be aimed at better quantification of trace constituents in the atmosphere.

Water Vapor Detection—Attempts will be made to detect water vapor in the atmosphere and these measurements will be coordinated with the orbital observations.

Soil Experiments—Incubation of soil in hydrogen is aimed at detection of reaction products and volatiles.

5. Inorganic Chemistry Analysis

The capacity for analyzing soil samples still exists with the XRFS in each Lander. If there is a planetwide dust storm, an analysis of the newly deposited material can be performed. On Lander 1, attempts will be made to acquire and analyze rock pebbles, "dark fines," and a very shallow sample to determine if the thin surface layer is chemically different from the bulk fines. A sample from a depth in excess of 10 cm will test homogeneity of surface material in the vertical direction. On Lander 2, similar acquisitions and analyses will be conducted, including a series of calibration operations to look for wind-blown material.

6. Magnetic Properties Investigation

Experiments will test the temperature dependence, if any, of the magnetic particles, and will attempt to pick up rock pebbles with the magnet. The backhoe magnets must first be cleaned with the magnet cleaning brush.

7. Physical Properties Investigation

Emphasis will be placed on trenching as deeply as possible, performing bearing strength and impact tests, mapping the area around the footpads and under the terminal descent engines using the boom-mounted mirrors, measuring surface temperatures through a diurnal cycle with the collector head temperature sensor, and examining surface material via the magnifying mirror. Long-term observations of the UV degradable coating will be conducted.

8. Surface Sampler

The boom will be operated to obtain the biology, GCMS, and XRFS samples and support the magnetic and physical properties investigations.

9. Imaging

The first objective will be to complete those composite imaging sequences started during the primary mission. The solar extinction, sky bright-

ness, and twilight rescan experiments for monitoring the changes in the amounts and types of particulate matter in the atmosphere will be continued. These experiments will aid in understanding the normal state of the Martian atmosphere and the changes during a dust storm. Monitoring of the fine grained dunes and dust gathered on rocks will be continued through any dust storms. Color observations of Phobos and Deimos will also be made to determine their composition.

10. Data Return

To return the science data and stay within the extended mission constraints, a maximum of four relay links per Lander in every two-week period will be scheduled. The relays will vary because the Orbiters are "walking" around the planet. This involves changing the periapsis of the Orbiter to allow investigation of other areas of the planet. Relays are planned until October 1977, at which time the direct link will become the only link used for data return.

There will be one command uplink to each Lander per week, with a contingency uplink planned on the next day. There will be two direct links planned for each Lander in a two-week cycle, and there will be no more than two Lander downlinks per day, in any combination.

B. LANDER 1 CAPABILITIES

The two Landers proved that they could properly execute some 40 sols of the mission without being commanded over the conjunction period. Lander 1 performed its mission throughout the conjunction period with only one anomaly detected: track 4 of the tape recorder produced data that could not be data frame synchronized or identified by the ground data processing software. Track 4 data had been recorded over a portion of the conjunction period and is not usable. However, the other three tracks continue to operate in an excellent fashion and will be adequate for the remainder of the extended mission.

The current operational configuration of Lander 1 includes the continued use of GCSC-A, DAPU-A, PCDA power converter A, modulation exciter-2, TWTA-1 and SSCA-A. There are operable backup components for all these items, if any should fail. This redundancy certainly maximizes the chance for successfully completing this long-

duration mission. Table VII-1 lists the hardware failures experienced to date and when the failures were detected. Table VII-2 lists the backup hardware status and when it was last operated.

Table VII-1 Lander 1 Landed Mission Hardware Failures

Item	Failure Description	Time of Detection
GCMS Oven 3	Oven pyrolysis heater open circuit	Cruise Test of GCMS
Seismometer	Three caging pinpullers failed to actuate	Sol 0
Command Receiver 1	Failure to lockup on uplink signal	Sol 2
Meteorology Sensor Assembly	Quadrant sensor heater developed open circuit	Sol 46
Tape Recorder	Track 4 produced unusable data	Sol 150 playback

Table VII-2 Backup Hardware Status

Item	Lander 1		Lander 2	
	Last Operated	Status	Last Operated	Status
GCSC-B	In Mars Orbit	Nominal	In Mars Orbit	Nominal
DAPU-B	Prelaunch	Nominal	Prelaunch	Nominal
TWTA 1	In Use	Nominal	Sol 38	Failed
TWTA 2	Sol 66	Nominal	In Use	Nominal
Cmd Receiver 1	Sol 1	Failed	Sol 131	Not Usable
Mod Exciter 1	Prelaunch	Nominal	Prelaunch	Not Usable
SSCA 2	Prelaunch	Nominal	Prelaunch	Nominal

To maintain the command, data collection and storage, and data transmission capability in an acceptable manner, operational workarounds (tape recorder track 4 problem) and use of redundant hardware (command receiver failure) have been used to overcome the few hardware failures experienced. The one exception is the failure to uncage the seismometer. However, special uncaging sequences are planned during the extended mission in an attempt to enhance the scientific data return from Lander 1. All of these points substantiate the fact that the Lander system is certainly adaptive and sufficient to realize the objectives of the extended mission.

C. LANDER 2 CAPABILITIES

Lander 2 performed its mission throughout the conjunction period in a flawless manner. This 40-sol mission period gave us the first indications of the oncoming Martian winter. The daily average

temperature in the Lander equipment compartment decreased about 8°F over this period. This cooling trend was predicted.

The current operational configuration of Lander 2 includes the continued use of GCSC-A, DAPU-A, PCDA power converter A, and SSCA-A. There are operable backup components for all these items, if any should fail. Lander 2 also proceeds into the mission with hardware redundancy which maximizes the chance of successfully completing the extended mission. Table VII-3 lists the hardware failures experienced to date and when the failure was detected. Table VII-2 lists the backup hardware status and when it was operated.

Table VII-3 Lander 2 Landed Mission Hardware Failures

Item	Failure Description	Time of Detection
Battery A Temperature Transducer	Open circuit	Prelaunch Checkout
GCMS Oven 1	Oven pyrolysis heater open circuit	Cruise Test of GCMS
SSCA Collector Head Intermediate Switch	Open circuit developed during sample delivery (did not affect subsequent operations)	Sol 8
TWTA 1	Indication of corona arcing	Sol 39
Command Receiver 1	Failure to lockup on uplink signal	Sol 102

Lander 2 will be severely stressed by the thermal environment expected for this northerly landing site. Figure VII-1 shows the calculated temperature profile projected for the next several months, including the Martian winter. The diurnal cycle decreases in magnitude until it disappears between sols 290 and 370. During this period, the atmosphere will begin to freeze out and maintain a constant temperature.

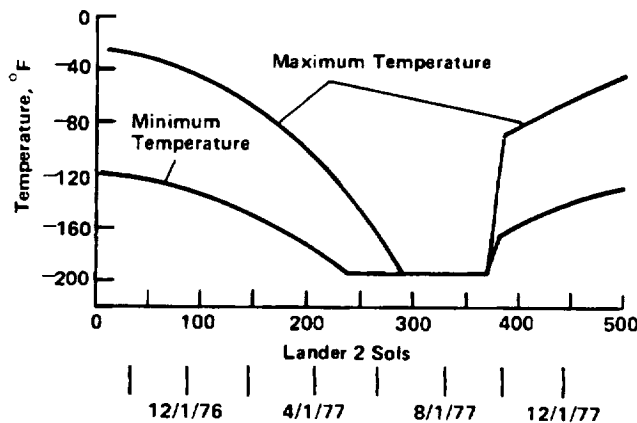

Figure VII-1 Lander 2 Environmental Predictions

The two thermal switches, which conduct waste RTG heat into the equipment compartment, first began to cycle on sol 119 and have continued to cycle each sol since then. This heat augments the heat generated by the components themselves. Thermal analyses indicate that the Lander internal equipment should be operable throughout this extreme thermal excursion if all of the RTG electrical power is used by the right components and the thermal switches continue to function. Minimum flight acceptance temperatures will possibly be exceeded for the battery assemblies, the GCMS, both cameras, and the camera duster, and may require restricted use for certain of these items during this period.

The high-gain antenna assembly is of concern because carbon dioxide icing, which is not well understood, could possibly cause the antenna to stop tracking the Earth. This proper pointing is required since commanding must utilize receiver number 2, which is connected only to the high-gain antenna.

Weighing all of the above factors, it is believed that Lander 2 has an excellent opportunity of completing the extended mission in spite of the potentially severe winter on Mars.