

General Disclaimer

One or more of the Following Statements may affect this Document

- This document has been reproduced from the best copy furnished by the organizational source. It is being released in the interest of making available as much information as possible.
- This document may contain data, which exceeds the sheet parameters. It was furnished in this condition by the organizational source and is the best copy available.
- This document may contain tone-on-tone or color graphs, charts and/or pictures, which have been reproduced in black and white.
- This document is paginated as submitted by the original source.
- Portions of this document are not fully legible due to the historical nature of some of the material. However, it is the best reproduction available from the original submission.

(NASA-CR-135201) EFFECTS OF ILLUMINATION ON
THE CONDUCTIVITY PROPERTIES OF SPACECRAFT
INSULATING MATERIALS Final Report (Stanford
Research Inst.) 84 p HC A05/MF A01 CSCL 11D

N77-30178

G3/24

Unclas
42000

NASA CR-135201

Final Report

July 1977

EFFECTS OF ILLUMINATION ON THE CONDUCTIVITY PROPERTIES OF SPACECRAFT INSULATING MATERIALS

By: R. C. ADAMO J. E. NANEVICZ

Prepared for:

NATIONAL AERONAUTICS AND SPACE ADMINISTRATION
LEWIS RESEARCH CENTER
21000 BROOKPARK ROAD
CLEVELAND, OHIO 44135

Attention: MR. NORMAN GRIER

CONTRACT NAS3-20080



STANFORD RESEARCH INSTITUTE
Menlo Park, California 94025 · U.S.A.



STANFORD RESEARCH INSTITUTE
Menlo Park, California 94025 U.S.A.

NASA CR-135201

Final Report

July 1977

EFFECTS OF ILLUMINATION ON THE CONDUCTIVITY PROPERTIES OF SPACECRAFT INSULATING MATERIALS

By: R. C. ADAMO J. E. NANEVICZ

Prepared for:

NATIONAL AERONAUTICS AND SPACE ADMINISTRATION
LEWIS RESEARCH CENTER
21000 BROOKPARK ROAD
CLEVELAND, OHIO 44135

Attention: MR. NORMAN GRIER

CONTRACT NAS3-20080

SRI Project 4904

Approved by:

T. MORITA, *Director*
Electromagnetic Sciences Laboratory

RAY L. LEADABRAND, *Executive Director*
Electronics and Radio Sciences Division

Copy No.4.....

FOREWORD

The objective of the program described in this report is to provide experimental data on the dark and illuminated conductivities of Kapton V and polyvinylidene fluoride (PVF₂) films, and on the changes in insulating properties produced in Kapton H, Kapton V, PVF₂, and FEP Teflon films as a result of prolonged exposure to solar illumination. The results described herein should aid those involved in spacecraft materials selection to predict the effects of illumination on the electrical properties of these materials.

An overall summary of the results of tests described in the major portion of this report along with some conclusions and recommendations for future work are given in Section 5.

A general introduction and a description of the experimental apparatus and procedures used for this program are given in Section 1.

A brief summary of the results of short-term dark and illuminated metal-electrode tests of Kapton V, PVF₂, and Styrene is given in Section 2.1 and the actual results of these tests are presented in Sections 2.2 through 2.4.

A summary of the results of dark and illuminated short-term electron-beam tests of Kapton V and PVF₂ is given in Section 3.1 with the test results presented in Sections 3.2 and 3.3.

The results of 24-hour illumination tests of Kapton H, Kapton V, PVF₂, and FEP Teflon are summarized in Section 4.1 and the data from these tests are presented in Section 4.2.

CONTENTS

FOREWORD	iii
LIST OF ILLUSTRATIONS	vii
1. INTRODUCTION	1
1.1 Background	1
1.2 Experimental Apparatus and Procedures	3
2. SHORT-TERM METAL-ELECTRODE TESTS	9
2.1 Summary and Comments	9
2.2 Results of Short-Term Dark Metal-Electrode Tests	10
2.3 Results of Short-Term Illuminated Metal-Electrode Tests	22
2.4 Results of Styrene Tests	33
3. SHORT-TERM ELECTRON-BEAM TESTS	37
3.1 Summary and Comments	37
3.2 Results of Short-Term Dark Electron-Beam Tests	39
3.3 Results of Short-Term Illuminated Electron-Beam Tests	47
4. 24-HOUR ILLUMINATION TESTS	57
4.1 Summary and Comments	57
4.2 Results of 24-Hour Illuminated Metal-Electrode and Illuminated Electron-Beam Tests	60
5. OVERALL SUMMARY AND CONCLUSIONS	71
5.1 Summary	71
5.2 Conclusions and Recommendations	72
REFERENCES	77

ILLUSTRATIONS

1-1	Test Setup and Electrode Configuration for Metal-Electrode Tests	6
1-2	Test Setup for Electron-Beam Tests	8
2-1	Dark Bulk-Current Density vs Applied Voltage in 5-mil Kapton V at 22, 66, and 100°C	11
2-2	Dark Bulk-Current Density vs Applied Voltage in 2-mil PVF ₂ at 22, 66, and 100°C	12
2-3	Dark Bulk-Current Density vs Applied Voltage in 1-mil PVF ₂ at 22, 66, and 100°C	13
2-4	Dark Bulk-Current Density vs Applied Voltage in 0.25-mil PVF ₂ at 22, 66, and 100°C	14
2-5	Dark Bulk-Current Density vs Applied Voltage in PVF ₂ , Kapton V, FEP Teflon, and Quartz at 66°C	16
2-6	Dark Bulk Resistivity vs Applied Electric Field in 5-mil Kapton V and 2-mil PVF ₂	17
2-7	Dark Surface Resistivity vs Applied Voltage for Kapton V	19
2-8	Dark Surface Resistivity vs Applied Voltage for PVF ₂	21
2-9	Dark and Illuminated Bulk-Current Densities and Bulk Resistivities in 5-mil Kapton V at 22°C	23
2-10	Illuminated Bulk-Current Density vs Applied Voltage in 5-mil Kapton V at 22, 66, and 100°C	25
2-11	Illumination Power Densities vs Wavelength with Various Optical Bandpass Filters	27
2-12	Normalized Illuminated Bulk-Current Density vs Wavelength in 5-mil Kapton V at 22°C	28
2-13	Optical Transmission vs Wavelength in 5-mil Kapton V and 2-mil PVF ₂	29
2-14	Normalized Illuminated Bulk-Current Densities vs Wavelength in 5-mil Kapton V at 22, 66, and 100°C	30
2-15	Ratios of Bulk Currents at 100°C and 22°C vs Wavelength in 5-mil Kapton V	31
2-16	Normalized Illuminated Bulk-Current Density vs Wavelength in 2-mil PVF ₂ at 22°C	32
2-17	Dark and Illuminated Bulk-Current Densities vs Applied Voltage in 6-mil Styrene at 22 and 100°C	34

3-1	Effects of Test Sequence on Dark Bulk Currents in 5-mil Kapton V at 22°C	39
3-2	Dark Bulk-Current Densities vs Electron-Beam Energy in 5-mil Kapton V at 22, 66, and 100°C	43
3-3	Dark Bulk-Current Densities vs 1.5 nA/cm ² and 15 nA/cm ² Electron-Beam Energies in 5-mil Kapton V at 22°C	44
3-4	Dark Bulk-Current Densities vs Electron-Beam Energy in 2-mil PVF ₂ at 22, 66, and 100°C	45
3-5	Dark Bulk-Current Densities vs Electron-Beam Energy in 1-mil PVF ₂ at 22, 66, and 100°C	46
3-6	Dark Bulk-Current Densities vs Electron-Beam Energy in 0.25-mil PVF ₂ at 22, 66, and 100°C	47
3-7	Dark and Illuminated Bulk-Current Densities vs 1.5 nA/cm ² and 15 nA/cm ² Electron-Beam Energies in 5-mil Kapton V at 22°C	49
3-8	Illuminated Bulk-Current Densities vs Electron-Beam Energy in 5-mil Kapton V at 22°C with Several Beam-Current Densities	50
3-9	Illuminated Bulk-Current Densities vs Electron-Beam Energy in 5-mil Kapton V at 22, 66, and 100°C	51
3-10	Dark and Illuminated Bulk-Current Densities vs 1.5 nA/cm ² and 15 nA/cm ² Electron-Beam Energies in 2-mil PVF ₂ at 22°C	52
3-11	Illuminated Bulk-Current Densities vs Electron-Beam Energy in 2-mil PVF ₂ at 22, 66, and 100°C	53
3-12	Illuminated Bulk-Current Densities vs Electron-Beam Energy in 1-mil PVF ₂ at 22, 66, and 100°C	54
3-13	Illuminated Bulk-Current Densities vs Electron-Beam Energy in 0.25-mil PVF ₂ at 22, 66, and 100°C	55
4-1	Effects of 24 Hours of Illumination with No Applied Voltage on Dark Bulk Currents in 5-mil Kapton V at 22 and 66°C	61
4-2	Effects of 24 Hours of Illumination with No Applied Voltage on Dark Bulk Currents in 5-mil Kapton H at 22 and 66°C	63
4-3	Effects of 24 Hours of Illumination with an Applied Voltage of 5 kV on Dark Bulk Currents in 5-mil Kapton V at 22 and 66°C	64
4-4	Effects of 24 Hours of Illumination with an Applied Voltage of 5 kV on Dark Bulk Currents in 5-mil Kapton H at 22 and 66°C	65
4-5	Effects of 24 Hours of Illumination With and Without a 5-keV Electron Beam on Dark Bulk Currents in 5-mil Kapton V	66

4-6	Effects of 24 Hours of Illumination With and Without a 5-keV Electron Beam on Dark Bulk Currents in 5-mil Kapton V	67
4-7	Effects of 24 Hours of Illumination With and Without an Applied Voltage of 5 kV on Dark Bulk Currents in 5-mil FEP Teflon	68
4-8	Effects of 24 Hours of Illumination With and Without a 5-keV Electron Beam on Dark Bulk Currents in 5-mil FEP Teflon	68
4-9	Effects of 24 Hours of Illumination With and Without a 5-keV Electron Beam on Dark Bulk Currents in 2-mil PVF ₂	70

1. INTRODUCTION

1.1 Background

Many future satellites may require electric power in the kilowatt range for use in onboard systems as well as for possible transmission to earth as an energy source. One of the most efficient ways of generating high power on a satellite appears to be by connecting large numbers of solar cell array segments in series to produce outputs in the kilovolt range. The use of such high-voltage arrays can eliminate the need for dc-to-dc converters in some applications and the need for conductors with extremely-high-current-carrying capabilities in general.

The electrical insulators used in such arrays must be lightweight, must possess high dielectric strength and high leakage resistance, and must perform reliably and predictably in the space environment. Several characteristics of the space environment, including high vacuum, unfiltered solar radiation, and high- and low-energy charged particles, can significantly affect the critical properties of satellite insulating materials. In a previous laboratory program conducted under Contract NAS3-18912, some of the effects of vacuum, solar illumination, and charged particles on a few typical spacecraft insulating materials including Kapton H, FEP Teflon, quartz, and Parylene were investigated (Coffey et al., 1975).^{*} Each of these materials except Parylene is presently being widely used in the construction of passive thermal control systems for use on the outside of spacecraft.

One finding of that program was that the bulk conductivities of the materials tested were considerably higher during solar illumination. This effect was most pronounced in Kapton H, which increased in bulk conductivity by as many as four orders of magnitude while illuminated.

^{*}References are listed at the end of the report.

It was also found that the dark bulk conductivity of Kapton H after long periods of illumination might be as many as three orders of magnitude higher than its original value even after having been in the dark for several hours. This result suggested that semi-permanent or perhaps permanent degradation of the leakage-resistance properties of Kapton H could result from solar illumination in space.

Since the time of the original program, two other promising high-voltage spacecraft insulating materials have become more readily available. One of these materials, Kapton V, has less shrinkage than Kapton H at elevated temperatures. The other material, polyvinylidene fluoride, is available as a film less than 2 mils thick and has less microscopic pinholes than other films in this thickness range.

One objective of the program described in this report was to provide experimental data on the dark and illuminated conductivities of Kapton V and polyvinylidene fluoride films as a function of such parameters as material thickness and temperature, wavelength of illumination, applied voltage, and incident charged-particle energy. Another objective of this program was to further investigate the possibility of long-term changes in the electrical properties of those materials. These data may also be of use to those concerned with a phenomenon of considerable present interest--namely, spacecraft charging.

As mentioned above, thin-film dielectric materials such as Kapton H, FEP Teflon, and quartz are widely used in the fabrication of passive thermal-control materials that often cover large portions of the outside surfaces of modern spacecraft. It is now known that, under various environmental conditions, large differences in potential may develop between various portions of spacecraft surfaces and may result in attraction and deposition of contaminants as well as electrical breakdowns that can cause physical damage to materials and induce undesirable electrical transients in onboard electronic systems.

At present, the complex nature of the interactions between spacecraft materials and their environment that are responsible for spacecraft charging effects is not thoroughly understood. It is possible, however,

that some material properties such as high leakage-resistance, although desirable for high-voltage array applications, may be undesirable from the spacecraft charging point of view. If they are, materials such as Kapton that increase their electrical conductivity by several orders of magnitude and yet retain their thermo-optical properties under solar illumination may help to reduce spacecraft charging effects.

During the course of this program, an additional material, Styrene, was specified for inclusion in certain tests. This material was added because of its planned use in a specific spacecraft system as a coating for signal cables that would be directly exposed to the space environment. In this particular application, high leakage currents could produce undesirable system performance. The data obtained from the Styrene tests are included in this report.

Because of the limited scope of the present program it was not possible to characterize the interactions of the materials tested with all possible conditions of the space environment. Rather, tests were performed under a limited set of conditions to allow some of the basic properties of each of the materials to be compared.

An overall summary of the results of these tests as well as a discussion of their implications for materials selection are given in Sections 5.1 and 5.2 of this report.

1.2 Experimental Apparatus and Procedures

All the tests described in this report were performed in a vacuum chamber 30 inches in diameter by 36 inches high that is fitted to the top of a 16-inch NRC oil-diffusion pump equipped with a liquid nitrogen cryogenic baffle and a 16-inch gate valve. This chamber can attain a vacuum of the order of 10^{-6} torr with sizable outgassing loads so that tests may proceed with a minimum delay in waiting for system pumpdown. The chamber is equipped with a 9-inch-diameter viewing window and numerous ports for mechanical and electrical feedthroughs. For use in spacecraft material studies the test setup also includes an electron gun and a xenon lamp solar simulator.

The electron gun is of a special type designed at SRI and uses a multipactor electron source to provide a large-area uniform beam over a wide range of energies and current densities (Nanevich and Adamo, 1976). The electron-gun circuitry includes a sensitive feedback system to maintain the electron-beam current density at a present level over long periods of time. This feature was invaluable on this program because it allowed the system to reliably operate unattended for periods of many hours during the 24-hour exposure tests.

A large, grounded metal plate that could be positioned between the electron gun and the test sample by rotating a mechanical vacuum feed-through was used to allow the test sample to be shielded from the electron beam as required.

The xenon lamp used in these tests was a sealed-beam unit with an aluminum reflector and a sapphire window to enhance the output in the ultraviolet and infrared portions of the spectrum. The xenon lamp was mounted outside the vacuum chamber and samples were illuminated through a 6-inch-diameter fused quartz window mounted in the chamber wall.

In all tests in which illumination was required, a xenon lamp was used to produce an optical power density of 100 mW/cm^2 at the sample surface with 99.8% of the lamp output power in the 200-to-2100-nm wavelength range. The optical power density was measured before and after each test and readjusted if necessary. The maximum changes in lamp output intensity observed over 24 hours of continuous illumination were of the order of a few percent. The samples were shielded from illumination as required, using an opaque shutter assembly that totally prevents light from the illuminator from entering the vacuum chamber. In addition, during illuminated tests, a circular iris was used to restrict illumination to the front surface of the sample material and thereby prevent photoelectron emission from other surfaces within the test chamber. A highly regulated (0.025%) 20-kV power supply was used to apply potentials to samples in some tests and to supply accelerating voltages for the electron gun in other tests. All current measurements were made using HP425A picoammeters having a minimum current resolution of approximately 10^{-12} A.

Two different types of measurement setups were used to characterize the conduction properties of the materials tested on this program. The first of these is illustrated schematically in Figure 1-1. This setup uses a standard technique for determining the bulk and surface resistivities of insulating materials. Test samples for use in this setup were prepared by sputtering gold electrodes on both sides of the sample materials as shown. The rear-surface gold electrode was used as an electrical ground reference for the sample and to provide thermal conductivity to allow the temperature of the sample to be controlled by the sample mounting plate. The body of the sample mounting plate contains an electrical heater and copper coils through which water can be passed for cooling. The temperature of the mounting plate was measured using a thermistor embedded within the plate near its upper surface and controlled to within 1°C by a proportional temperature controller. The two optically transparent front-surface electrodes were instrumented and used in a standard guarded-electrode bulk-resistivity measurement configuration as shown in Figure 1-1. In this configuration, the outer guard electrode and the center metered electrode are maintained at the same potential to restrain current flow from the center electrode to the bulk of the material. With the instrumentation rearranged as described in Section 2.2, the 1.5-mm gap between the front-surface electrodes was used to perform surface-resistivity measurements.

With the electrode geometry shown in Figure 1-1, the area of the center electrode is 7.07 cm². The bulk resistivity (ρ_{bulk}) can therefore be calculated using the formula:

$$\rho_{\text{bulk}} = \frac{7.07 (10^{-4}) V}{I d} \text{ ohm-m}$$

where V is the applied voltage, I is the measured bulk-current, and d is the sample thickness in meters.

As shown in Figure 1-1, the test sample was held down and electrical contact to the guard electrode was made by means of a circular brass hold-down ring. Similarly, contact was made with the center metered electrode using a thin brass rod.

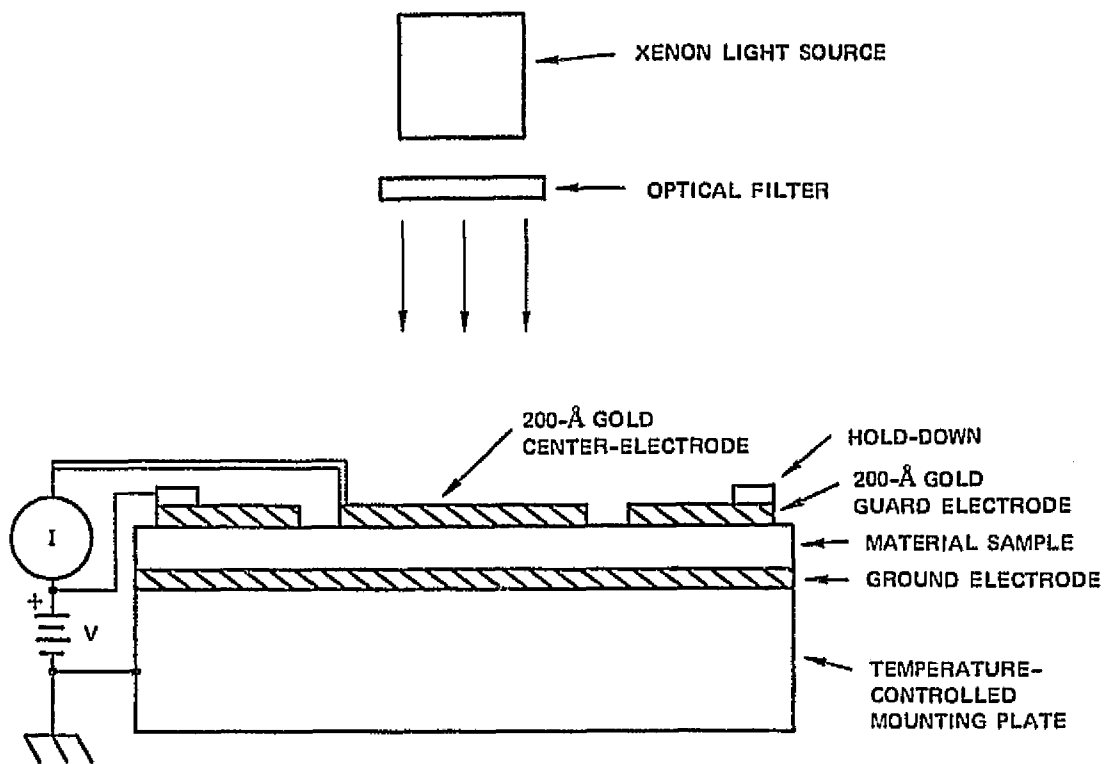

(a) TEST SETUP

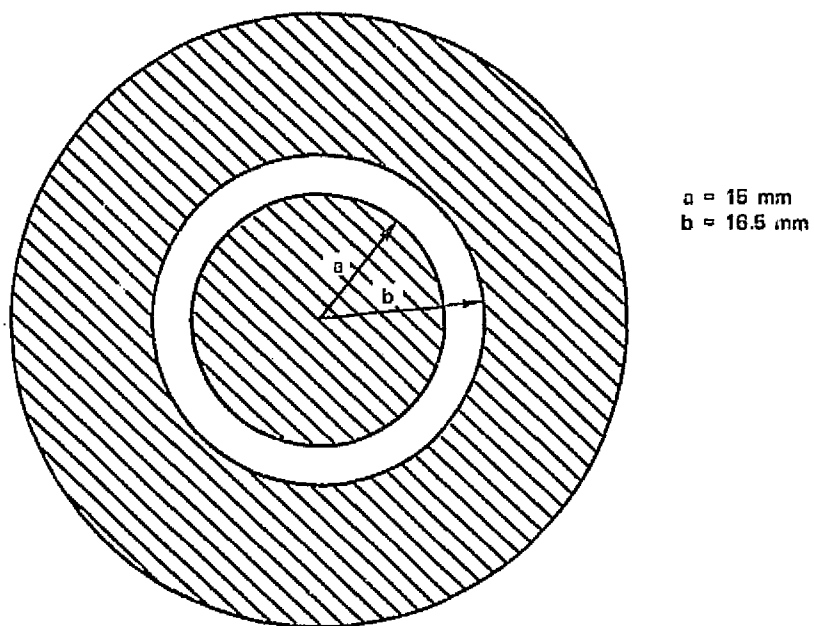

(b) FRONT-SURFACE GOLD ELECTRODE CONFIGURATION

SA-4904-39

FIGURE 1-1 TEST SETUP AND ELECTRODE CONFIGURATION FOR METAL-ELECTRODE TESTS

The metal-electrode test setup is extremely useful as a means for material characterization because it is typical of the type of setup generally used by material manufacturers to obtain resistivity data for use in published specifications. In addition, when metal-electrode tests are performed in a vacuum chamber and with simulated solar illumination, the test conditions are a reasonable representation of the conditions that would exist if the test material were used as a substrate for a high-voltage array.

However, the metal-electrode tests are not representative of conditions that would exist for materials used as solar cell covers or as thermal-control surfaces on spacecraft. In applications such as these, the insulating materials would not be sandwiched between conductive layers with a voltage maintained between them, but instead would have one surface directly exposed to illumination and to charged particles present in the space environment. For this reason, in addition to the metal-electrode tests, a series of tests were performed in which material bulk currents were measured with one side of the test samples exposed directly to an electron beam and, in some cases, simultaneously to illumination.

The test setup and sample electrode configuration used for these tests is shown schematically in Figure 1-2. The conductive gold electrodes deposited on the back surfaces of samples used for these tests were somewhat thicker but otherwise identical in dimensions to those on the front surfaces of the metal-electrode test samples. For use in the electron-beam test setup, the temperature-controlled sample mounting plate was equipped with a new face plate. The outer circular gold electrode was electrically grounded to the mounting plate and acted again as a guard electrode to prevent surface-leakage currents from being included in the bulk currents measured at the center electrode. Contact was made to the center gold electrode by a conductive disc. An electrically insulating thin film having high thermal conductivity was deposited on the underside of this disc to provide electrical isolation from the grounded mounting plate. As shown in Figure 1-2, the test samples were

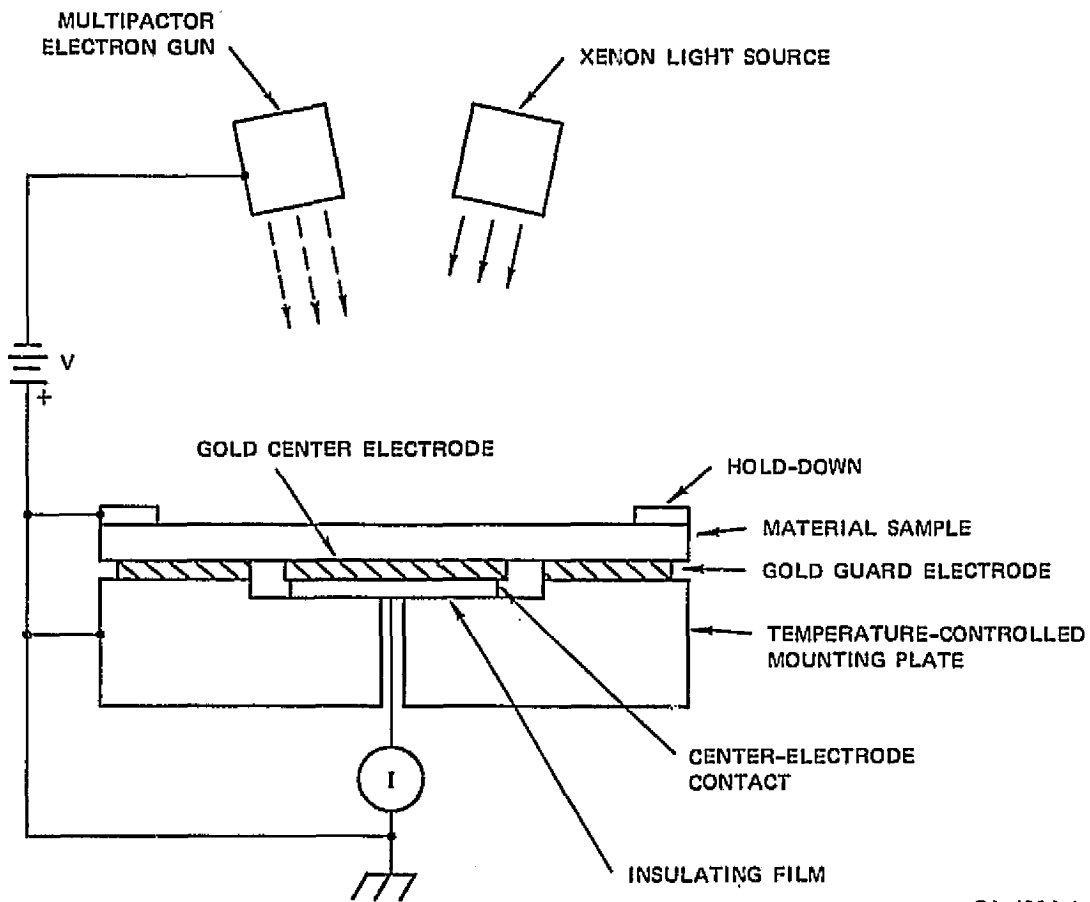

SA-4904-1

FIGURE 1-2 TEST SETUP FOR ELECTRON-BEAM TESTS

held down by a brass ring that was electrically connected to the sample mounting plate.

During the performance of initial metal-electrode tests, it was determined that, under certain test conditions, the application of high test voltages frequently caused electrical breakdown of, and physical damage to, test samples. Such occurrences often resulted in the loss of a considerable amount of time and data. For this reason, subsequent measurements were made using conservative, safe voltage levels established by experience for each sample material and thickness. In general, safe voltage limits were higher for thicker samples.

2. SHORT-TERM METAL-ELECTRODE TESTS

2.1 Summary and Comments

The results of short-term metal-electrode tests of Kapton V and PVF₂ performed both in the dark and with the samples illuminated are presented in Sections 2.2 and 2.3. The metal-electrode test setup used in these tests and described in Section 1.2 used standard techniques for the determination of the bulk and surface resistivities of insulating films.

The dark bulk resistivity of 5-mil Kapton V was found to decrease by as much as two orders of magnitude when the sample temperature was increased from 22°C to 100°C. The bulk resistivity of Kapton V at 22°C decreased by as much as four orders of magnitude when the sample was illuminated, and showed little further decrease in illuminated bulk resistivity when the temperature was increased to 100°C. The dark bulk resistivity of PVF₂ was found to be approximately three orders of magnitude lower than that of Kapton V at 22°C but, even in the dark, showed only a minor decrease with increased temperature. The dark bulk resistivities of 5-mil Kapton V and 2-mil PVF₂ with an applied electric field of 2 kV/mil differed by only a factor of 2x at 100°C. In all tests of Kapton V, the results were very similar to those previously obtained with Kapton H. The greatest enhancement of conductivity in Kapton V was found to be produced by illumination in the 500-to-580-nm wavelength range and in PVF₂ by wavelengths shorter than 470 nm.

In general, under the conditions of the tests performed, the resistivity of Kapton V as compared to that of PVF₂ is considerably higher in the dark at low temperatures, approximately the same in the dark at higher temperatures, and considerably lower when illuminated regardless of temperature. In addition, as is demonstrated in Section 4, Kapton V may take a much longer time to recover its initial dark properties after periods of illumination.

Some considerations regarding choices between these and other materials for various applications are discussed in Section 5. The results of a limited number of dark and illuminated metal-electrode tests of a material called Styrene are presented in Section 2.4.

The dark bulk resistivity of 6-mil Styrene was found to be comparable to that of Kapton and FEP Teflon but, unlike these and other materials tested, the bulk resistivity of Styrene increased by only an order of magnitude or less under illumination. However, since Styrene is an opaque white material and is not readily available in the form of large-area thin-film sheets, it might not be considered for many applications in which other materials could be used.

2.2 Results of Short-Term Dark Metal-Electrode Tests

The values of dark bulk-current density given in this section were each obtained one minute after the corresponding voltages were applied. In most of these tests, the initial displacement currents appeared to have become negligible and the measured conduction currents were relatively stable after 60 s. However, in many cases the measured currents were not completely stable after 60 s, and the 60-s standard was therefore strictly adhered to in order to allow a direct comparison among data obtained in different tests.

The results of dark bulk-current measurements on 5-mil Kapton V at 22, 66, and 100°C are shown in Figure 2-1. It can be seen from this figure that the dark bulk conductivity of Kapton V increases considerably with increasing temperature. In all short-term tests performed using Kapton V, the results were remarkably similar to those obtained previously using Kapton H. For example, the results of previous tests on 5-mil Kapton H at 22°C are shown in Figure 2-1 for comparison. Both Kapton V and Kapton H were tested under identical conditions on this program during the 24-hour tests described in Section 4, where further comparisons between the two materials are made.

Figures 2-2, 2-3, and 2-4 illustrate the results of dark bulk-current tests on 2-, 1-, and 0.25-mil polyvinylidene fluoride (PVF₂)

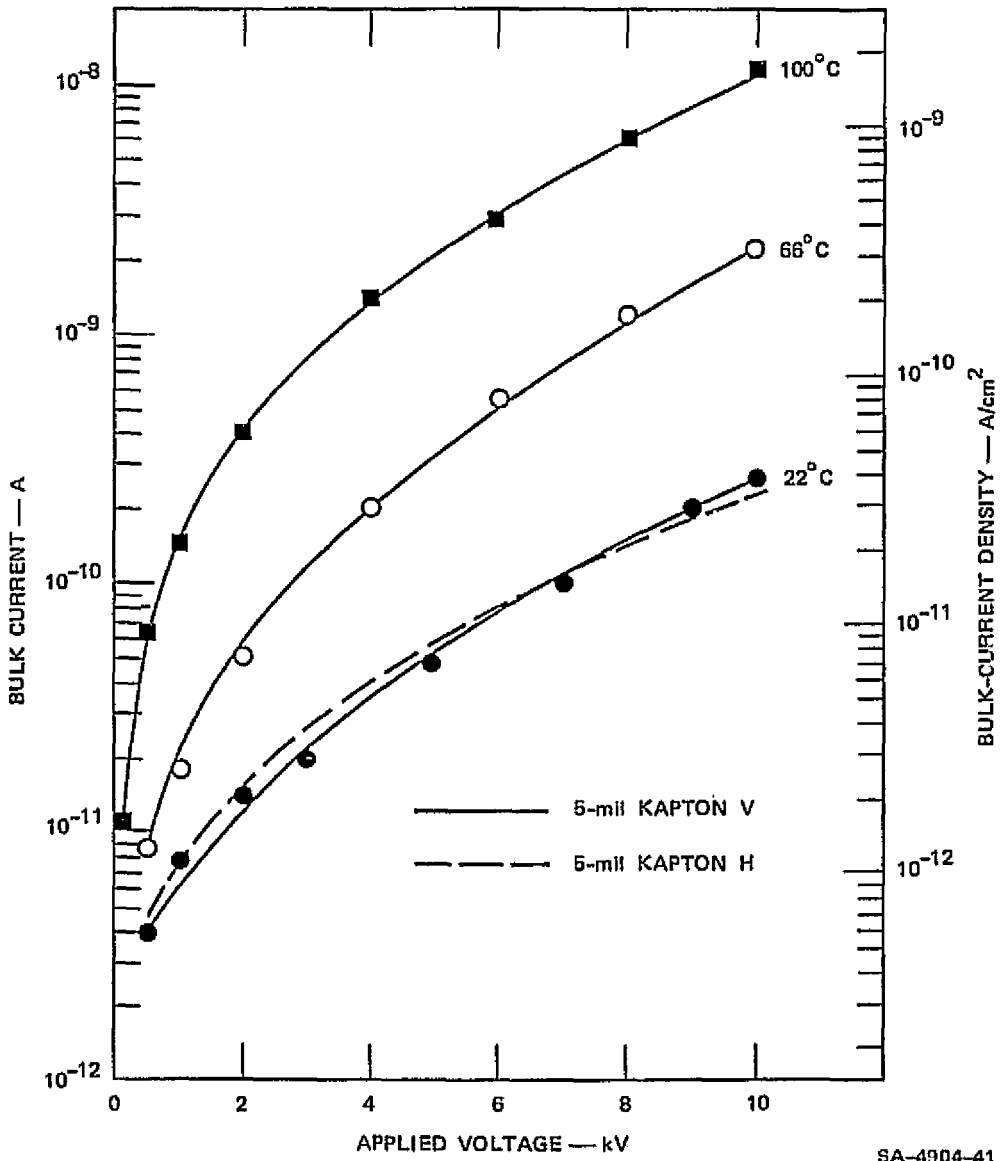

FIGURE 2-1 DARK BULK-CURRENT DENSITY vs APPLIED VOLTAGE IN 5-mil KAPTON V AT 22, 66, AND 100°C

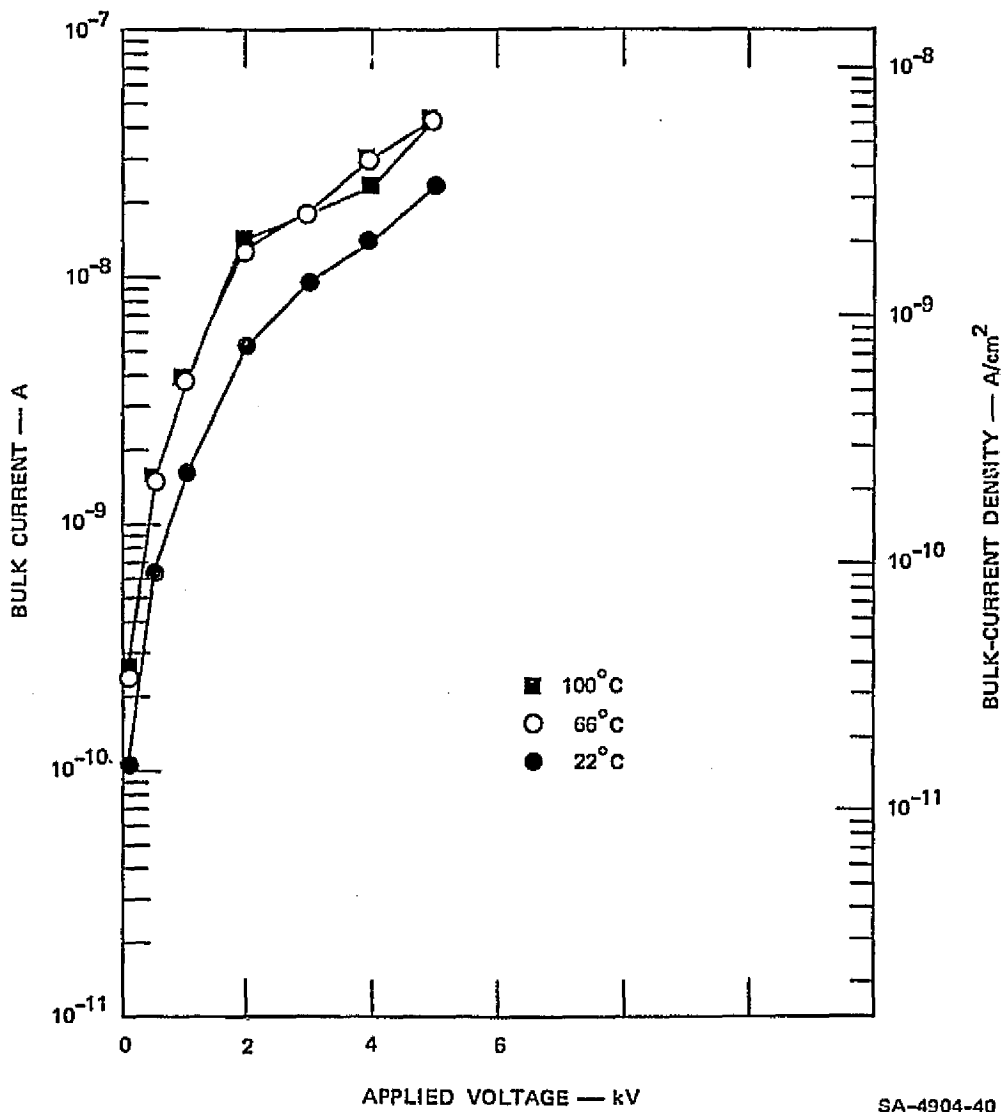

FIGURE 2-2 DARK BULK-CURRENT DENSITY vs APPLIED VOLTAGE IN 2-mil PVF₂ AT 22, 66, AND 100°C

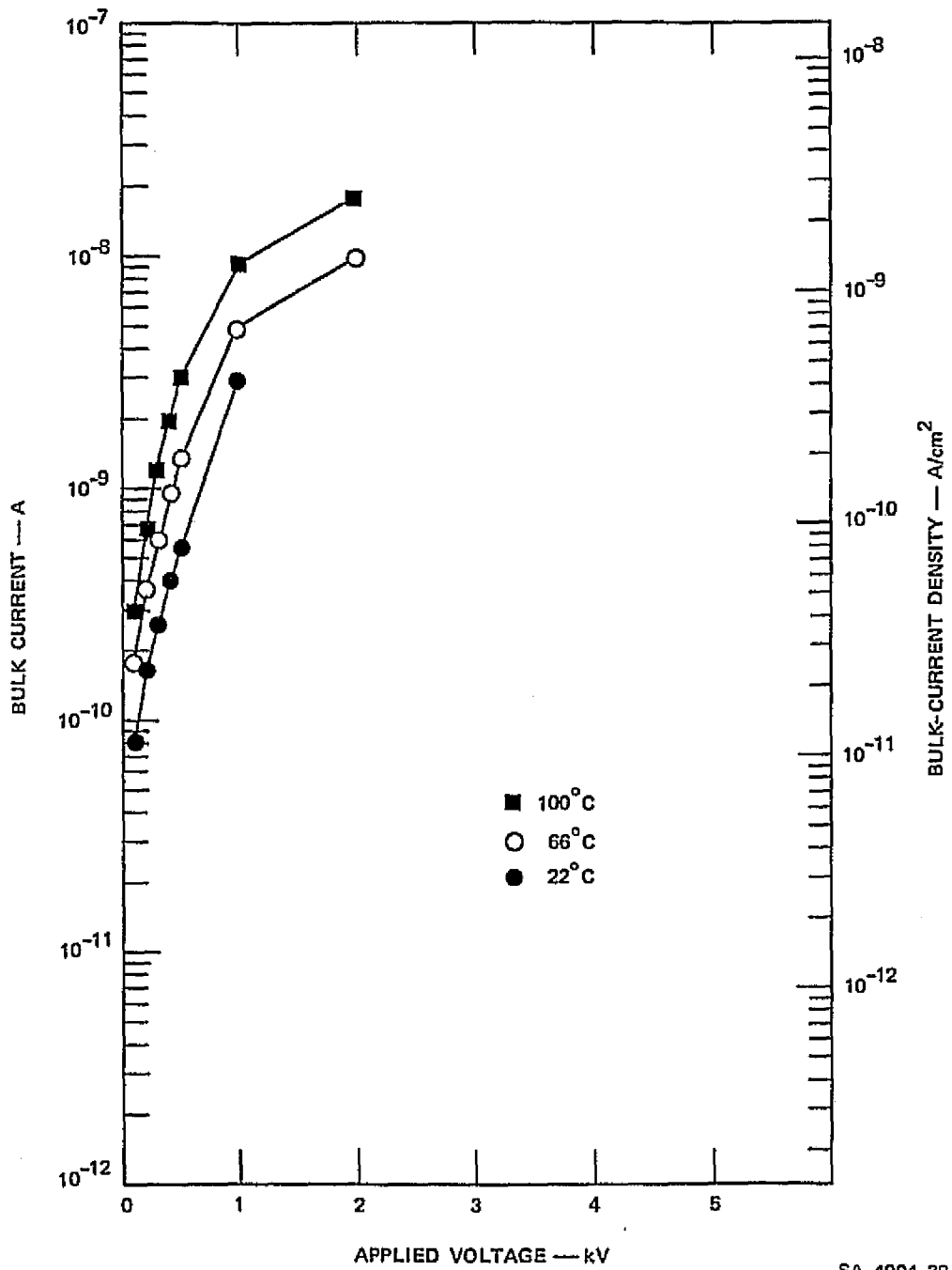

FIGURE 2-3 DARK BULK-CURRENT DENSITY vs APPLIED VOLTAGE IN 1-mil PVF₂ AT 22, 66, AND 100°C

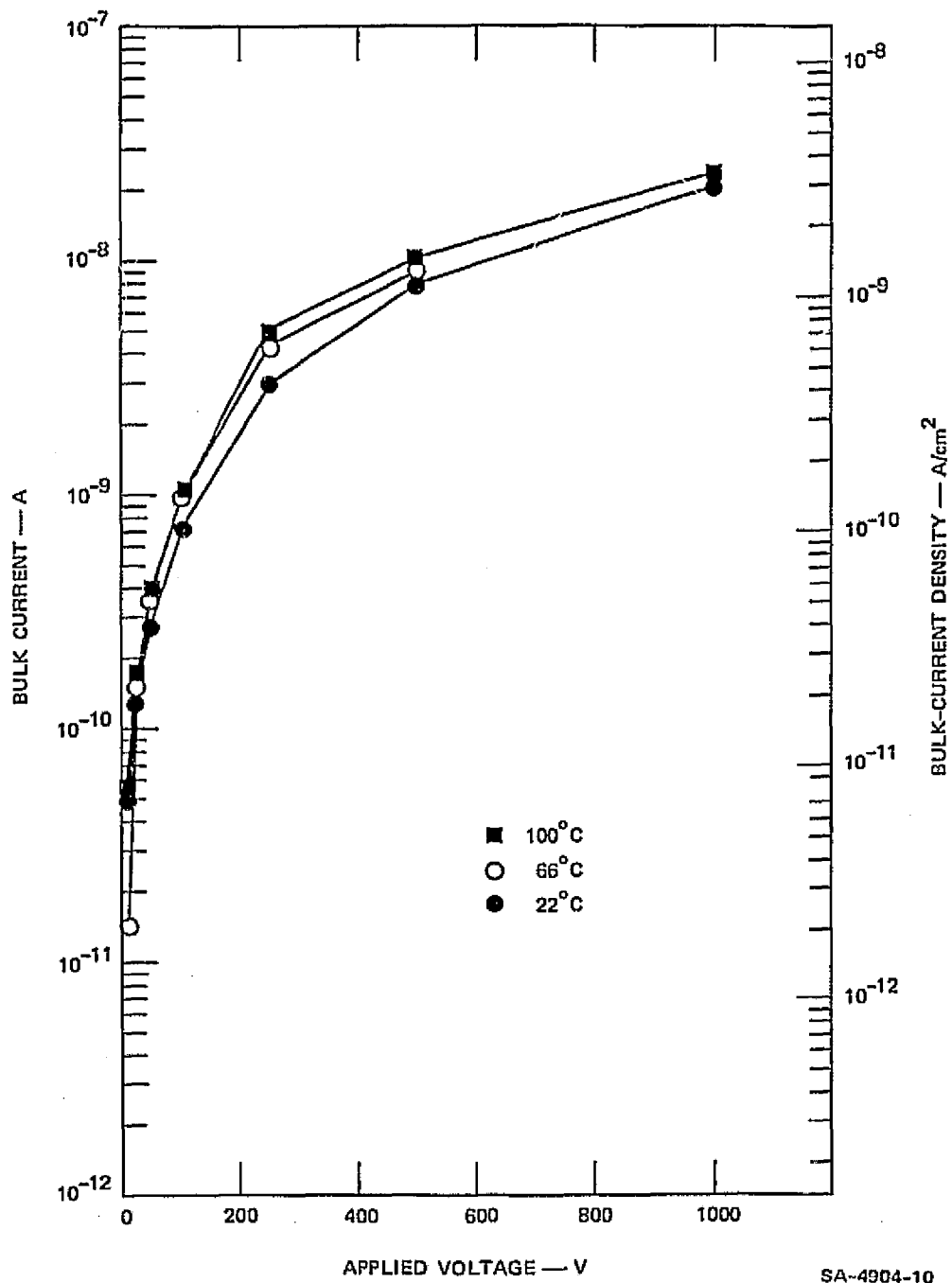

FIGURE 2-4 DARK BULK-CURRENT DENSITY vs APPLIED VOLTAGE IN 0.25-mil PVF₂ AT 22, 66, AND 100°C

samples. The effect of temperature changes on the measured values of dark bulk current is much less pronounced in PVF₂ than in Kapton V. There is considerable overlap among the raw data points shown in these figures for a given thickness of PVF₂ at the various test temperatures. Some of the overlap may be due to variations among different samples of material of the same thickness, since many samples were damaged during these tests and the data points shown are a compilation of data obtained using several samples. The maximum applied voltages were decreased particularly for thinner samples of PVF₂ in an effort to avoid sample breakdown and damage. In fact, the missing data points at 2 kV for 1-mil PVF₂ at 22°C and at 1 kV for 0.25-mil PVF₂ at 66°C are the result of severe sample damage due to the occurrence of electrical breakdowns before these voltages could be reached.

For comparison between some of the materials tested, the dark bulk-current densities measured at 66°C in PVF₂, Kapton V, FEP Teflon, and Quartz are shown in Figure 2-5. The data illustrated in this figure were obtained from the thickest samples of each material tested. As a general rule the dark bulk current has been found to increase with increasing applied voltages, increasing temperature, or decreasing material thickness. Within the ranges of the parameters covered in these tests, under comparable conditions, the highest dark bulk currents have been observed in PVF₂, followed by Kapton, FEP Teflon, and Quartz as shown in Figure 2-5. Some of the data from Figures 2-1 and 2-2 are replotted in Figure 2-6 to show the relationship between effective dark bulk resistivity and applied electric field. This figure illustrates that Kapton V exhibits a greater variation in dark bulk resistivity over the plotted ranges of temperature and applied electric field than does PVF₂.

Although not shown in Figure 2-6, with an applied electric field between 0.5 and 2.5 kV/mil the dark bulk resistivities of all three thicknesses of PVF₂ tested were within the range 10^{12} to 10^{13} ohm-m between 22 and 100°C. Below 0.5 kV/mil the maximum value of effective dark bulk resistivity observed in PVF₂ was $3.5 (10^{13})$ ohm-m in a 1-mil sample at 22°C and 0.1 kV/mil.

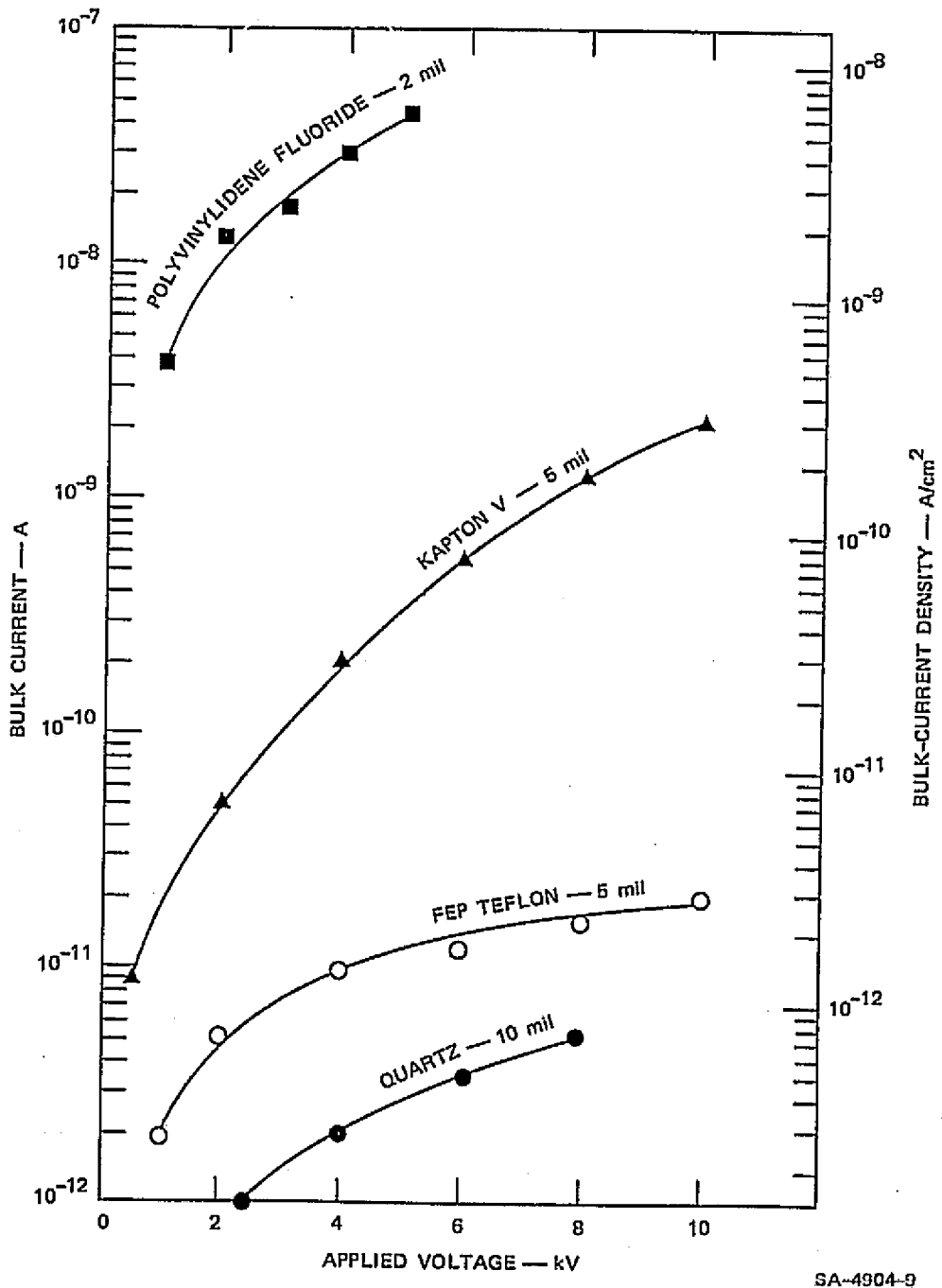

FIGURE 2-5 DARK BULK-CURRENT DENSITY vs APPLIED VOLTAGE IN PVF₂, KAPTON V, FEP TEFLON, AND QUARTZ AT 66°C

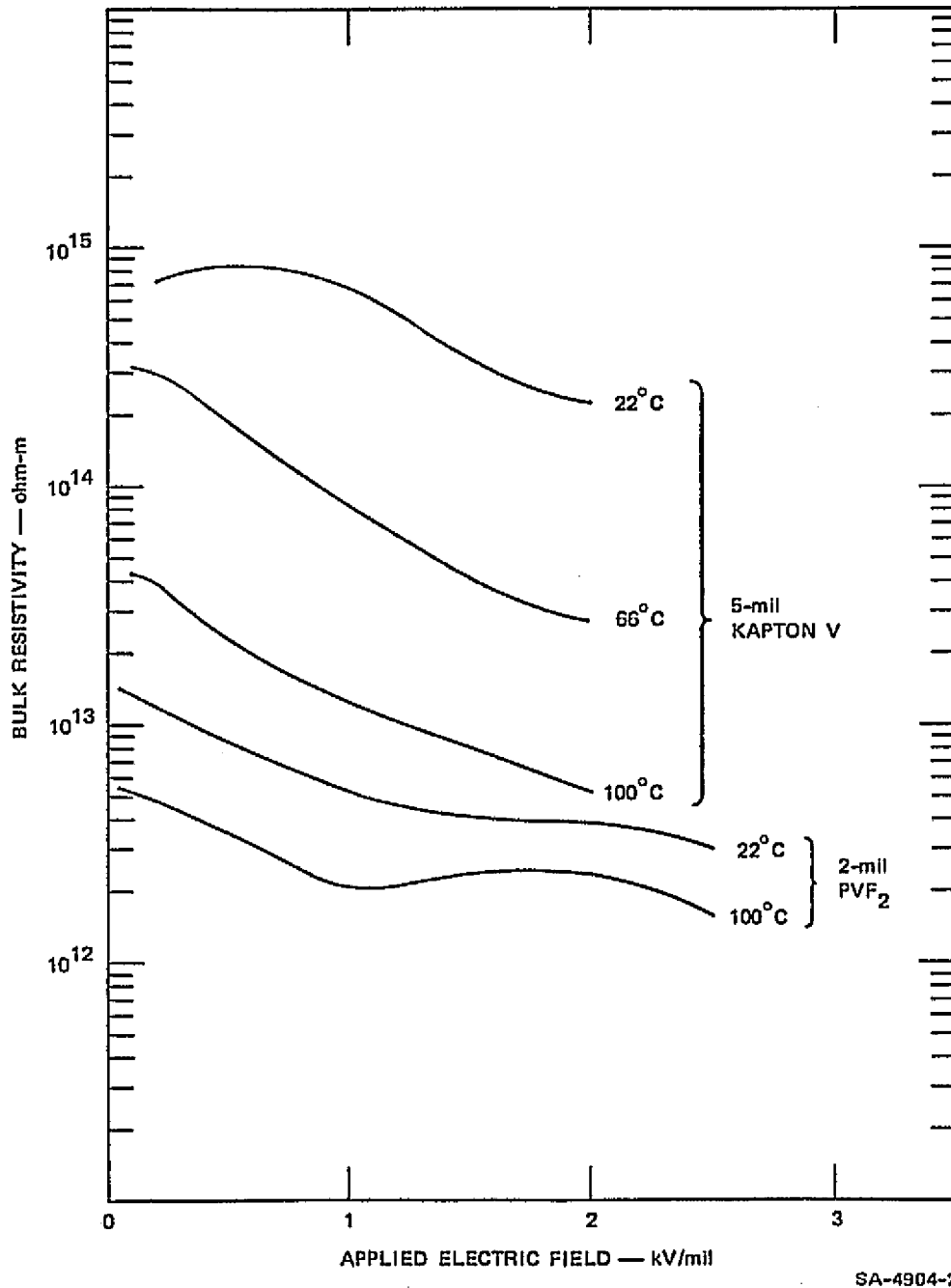

FIGURE 2-6 DARK BULK RESISTIVITY vs APPLIED ELECTRIC FIELD IN 5-mil KAPTON V AND 2-mil PVF₂

It can be seen from Figure 2-6 that with an applied electric field of 2 kV/mil, the dark bulk resistivity of Kapton V is approximately 50 times higher than that of PVF₂ at 22°C, but only approximately two times higher than that of PVF₂ at 100°C. Kapton V, therefore appears to be a much better "dark" insulator than PVF₂ at lower (22°C) temperature, but a comparable "dark" insulator at higher (100°C) temperature.

In addition to the bulk-current measurement configuration shown in Figure 1-1, provisions were made to readily convert the test setup to a surface-current-measurement configuration for the determination of sample surface-resistivities. In the surface-current configuration, the high-voltage power supply was connected between the front-surface center electrode and the back-surface ground electrode, while the current meter was connected between the front-surface outer electrode and the back-surface ground electrode. A voltage was therefore applied between the center and outer electrodes on the front surface, and the current flowing between these two electrodes was measured directly.

The geometry, size, and spacing of the front-surface electrodes deposited on the test samples are such that the surface resistivity can be calculated as:

$$\rho \text{ surface} = \frac{66.4 \text{ V}}{I} (\Omega/\square)$$

where V is the applied voltage and I is the measured surface current.

Results of dark surface-resistivity measurements on 5-mil Kapton V at 22, 66, and 100°C are shown in Figure 2-7. All of the data shown in this figure were obtained from the same test sample. The tests were performed approximately 30 minutes apart in the sequence indicated by the numbers in parentheses. Surface resistivities on the order of $10^{16} \Omega/\square$ are typical of the several samples of Kapton V tested. It is believed, however, that the actual surface resistivity of perfectly clean and outgassed Kapton V may be somewhat higher, since, in general, the measured surface currents tended to decrease with time in the vacuum chamber, particularly at higher temperatures.

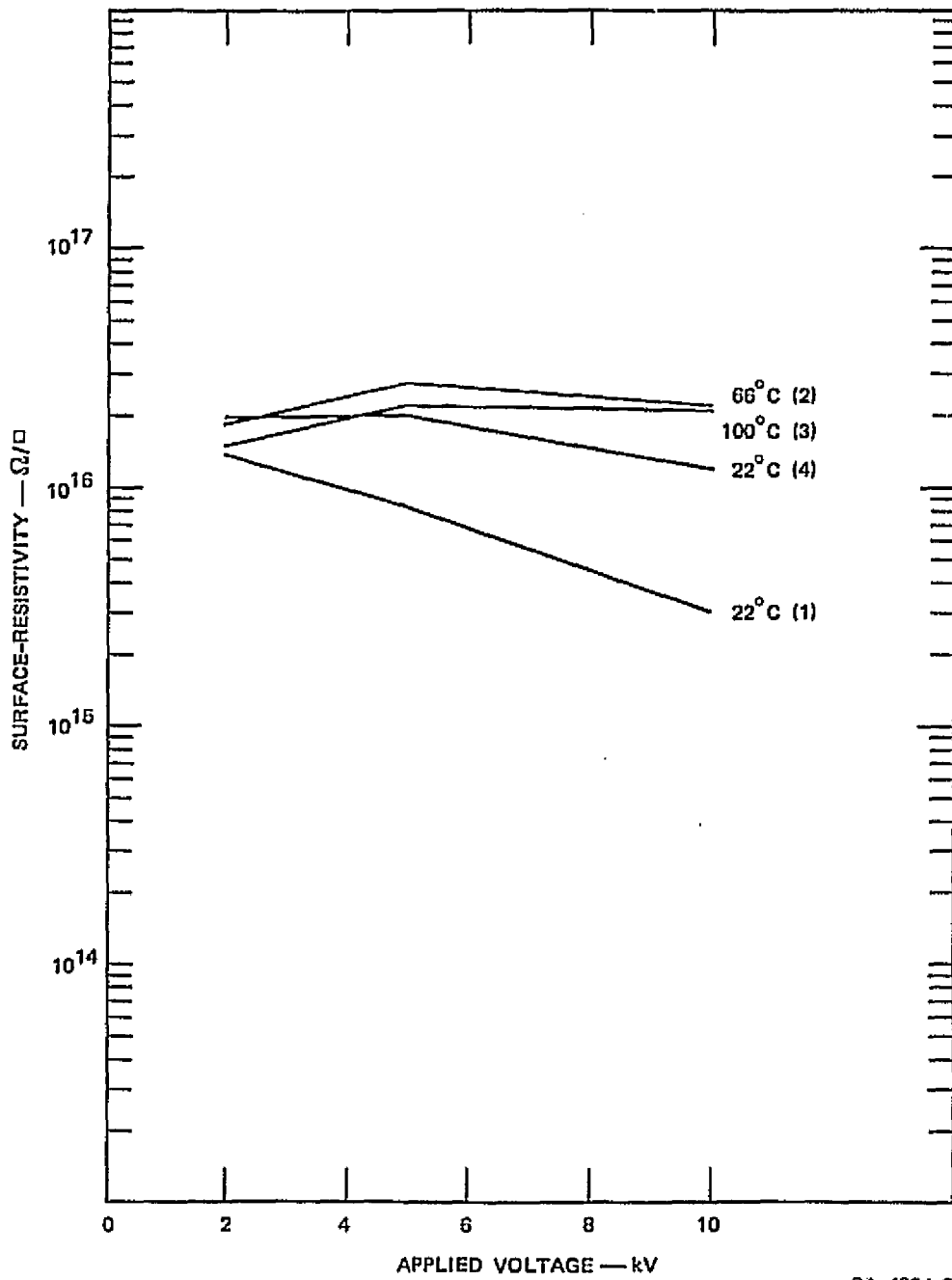

SA-4904-3

FIGURE 2-7 DARK SURFACE RESISTIVITY vs APPLIED VOLTAGE FOR KAPTON V

The samples were carefully cleaned using high-purity isopropyl alcohol prior to deposition of the electrodes and were stored thereafter in sealed plastic bags in the normal laboratory environment until tested. The surface-resistivity values shown in Figure 2-7 are therefore most likely typical of reasonably clean samples and, if more extensive cleaning techniques are used, higher values of surface-resistivity could be expected.

Surface-resistivity measurements were also performed on PVF₂ samples; however, in these tests, several problems were encountered. In initial tests, with a 2-mil PVF₂ sample at 22°C, the results shown as the upper curve in Figure 2-8 were obtained.

Following this surface-resistivity test at 22°C, a bulk-resistivity test was performed at the same temperature, and then an attempt was made to repeat the initial surface-resistivity test to confirm the previous results. It was found that surface currents comparable to those previously measured with an applied surface voltage of 2 kV were obtained with no voltage applied to the sample. With a surface voltage applied, the magnitude of the measured surface current was found to decrease as the voltage was increased.

Since this effect appeared to be a result of charge storage in the sample as a result of the previous bulk-resistivity test, a new previously untested sample was used for the next surface-resistivity test at 66°C. The results of this test are also shown in Figure 2-8. The repetition of surface tests on this sample after bulk tests had been performed produced anomalous results similar to those obtained at 22°C.

An additional new sample was therefore used for the 100°C tests. Upon heating of this previously untested sample to 100°C, a steady surface current of approximately $2 (10^{-11})$ A was obtained with no surface voltage applied. This surface current increased slightly as surface voltages were applied, and reached a value of $6.6 (10^{-11})$ A with an applied voltage of 2 kV. The surface-resistivity values calculated using these measured surface currents are also shown in Figure 2-8. Similar results at 100°C were obtained using an additional new 2-mil PVF₂

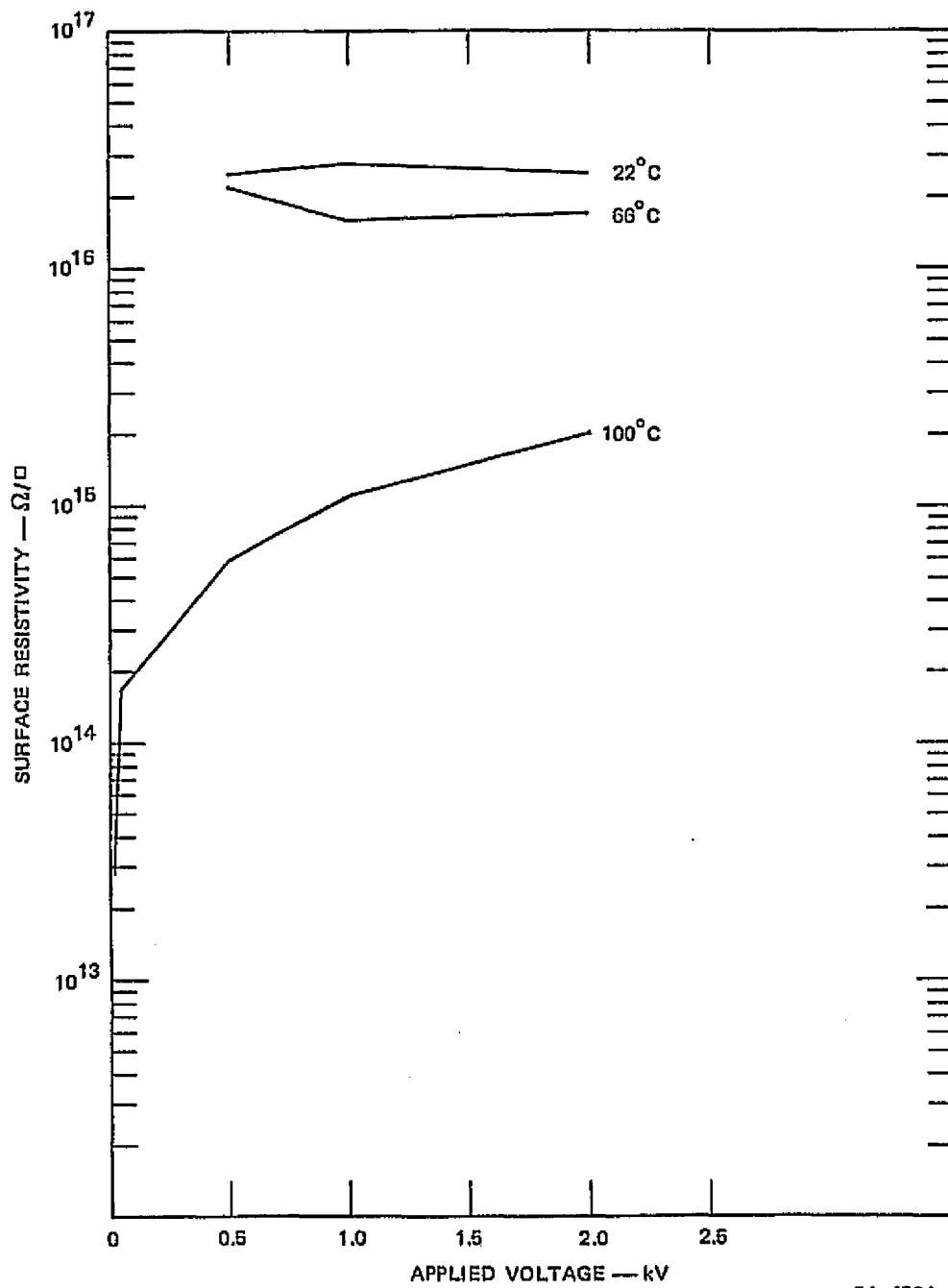

FIGURE 2-8 DARK SURFACE RESISTIVITY vs APPLIED VOLTAGE FOR PVF₂

sample. Surface-resistivity tests were also performed on 1- and 0.25-mil PVF₂ samples. The results of these tests were both qualitatively and quantitatively similar to those shown in Figure 2-8.

Therefore, although the surface-resistivity measurements were performed using standard and accepted techniques (Standard Methods ..., 1966) and the surface-resistivity values were calculated using a standard formula, it is obvious that other current-producing phenomena are involved. In fact, electret-effects of the type observed in the 22 and 66°C tests are common in materials such as PVF₂ (van Turnhout, 1975), and pyro-electric effects of the type observed at 100°C in PVF₂ have also been reported (Burkard and Pfister, 1974).

2.3 Results of Short-Term Illuminated Metal-Electrode Tests

The illuminated bulk-current density data presented in this section were obtained, as described in Section 1.2, by illuminating the front surface of the samples using a xenon lamp that produces an energy density of 100 mW/cm² at the sample location. All data discussed in this section were measured 60 s after the corresponding voltages were applied, and 20 s after the sample was exposed to illumination. Immediately after each current measurement was made, the test sample was shielded from illumination and the next value of voltage was applied. This standardized procedure was established to allow a direct comparison of data obtained in the various short-term illuminated-sample tests to be made.

The 30-s delay between the application of the test voltage and the exposure of the sample to illumination was necessary because, with illuminated samples, the large transient displacement currents produced by application of the higher test voltages often resulted in sample breakdown and damage.

The results of both dark and illuminated bulk-current measurements on 5-mil Kapton V at 22°C are shown in Figure 2-9. The illuminated bulk-resistivity curve was calculated from the illuminated bulk-current density data. The dark bulk-current density and dark bulk-resistivity data are taken from Figures 2-1 and 2-6 for comparison. It can be seen from

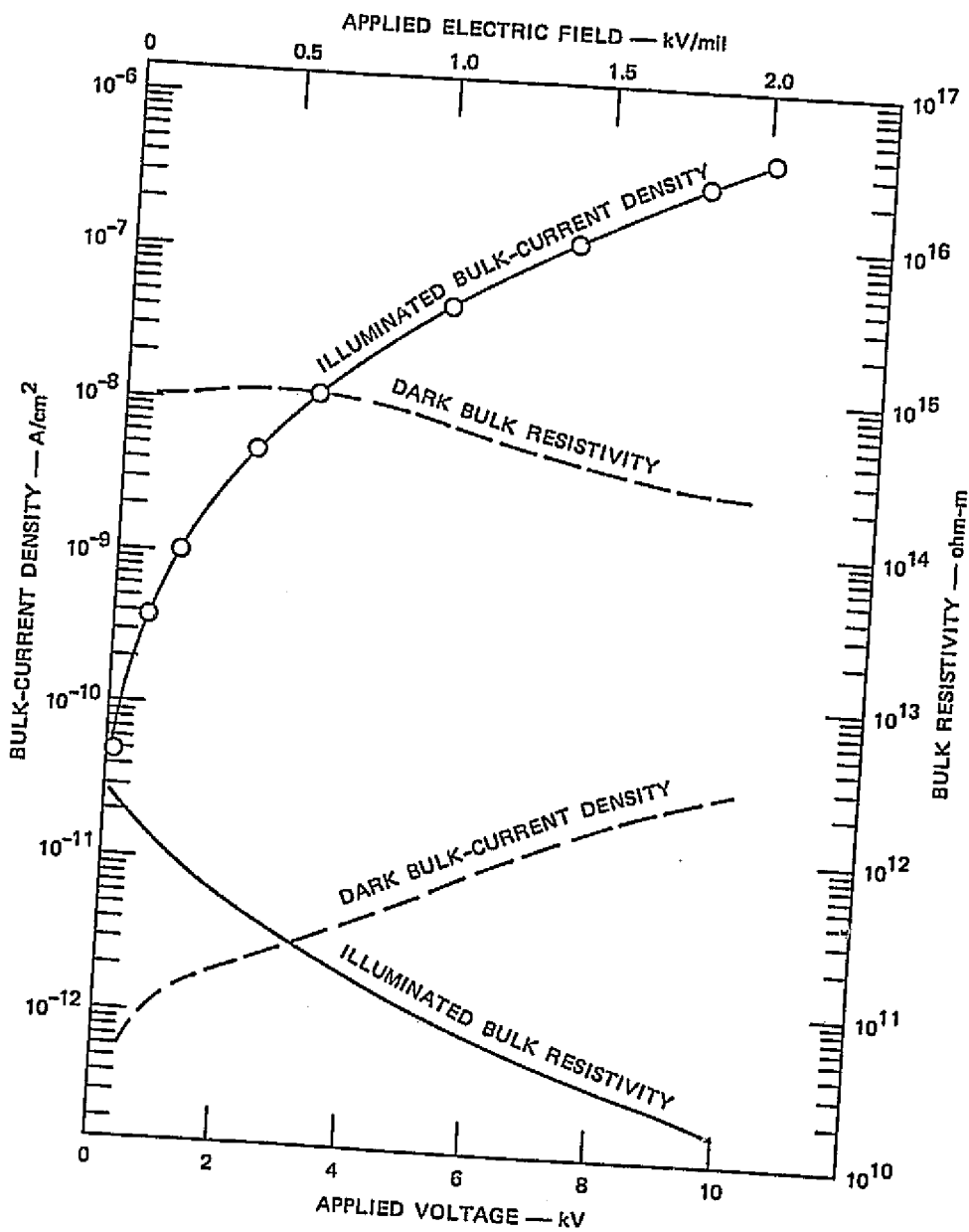

SA-4904-36

FIGURE 2-9 DARK AND ILLUMINATED BULK-CURRENT DENSITIES AND BULK RESISTIVITIES IN 5-mil KAPTON V AT 22°C

Figure 2-9 that the bulk-current density increases by more than four orders of magnitude at 10 kV when the sample is illuminated, and that the illuminated bulk resistivity drops by two orders of magnitude as the applied voltage is increased from 0.1 kV to 10 kV, while the dark bulk conductivity changes by less than a factor of 4 over the same range of applied voltages.

Illuminated bulk-current density data obtained at 22, 66, and 100°C are shown in Figure 2-10, from which it can be seen that the increase in illuminated bulk-current density produced by raising the temperature of 5-mil Kapton V from 22°C to 100°C is not nearly as pronounced as was observed in the dark bulk-current tests.

Illuminated tests of PVF₂ samples with gold front-surface electrodes were found to produce extremely high and inconsistent currents. For example, at 22°C, the observed current density through a 0.25-mil PVF₂ sample with an applied voltage of 100 V was greater than 3 (10⁻⁵) A/cm². When the applied voltage was increased to 200 V, several electrical breakdowns occurred that physically damaged the test sample and resulted in a permanent front-to-back short circuit. Similar results were observed with 1-mil and 2-mil PVF₂ samples, although at higher voltages. Visual examination of the tested PVF₂ samples indicated that they had been severely distorted, as if by overheating. Additional samples of PVF₂ with gold front-surface electrodes were therefore mounted in the test chamber and illuminated for periods of a few minutes with no applied voltage. These samples were also distorted and damaged by overheating.

In anticipation of the electron-beam tests, additional PVF₂ samples with back-surface electrodes only were installed in the test chamber and illuminated. In this case there were no noticeable physical effects.

It therefore appears that heating effects caused by the front-surface gold electrodes on PVF₂ are responsible for the observed physical damage. Consequently, additional tests requiring full-intensity illumination of front-surface metal-electrode PVF₂ samples were not performed. However, the results of tests in which the total power incident on metal-electrode PVF₂ samples was reduced using optical bandpass filters are described

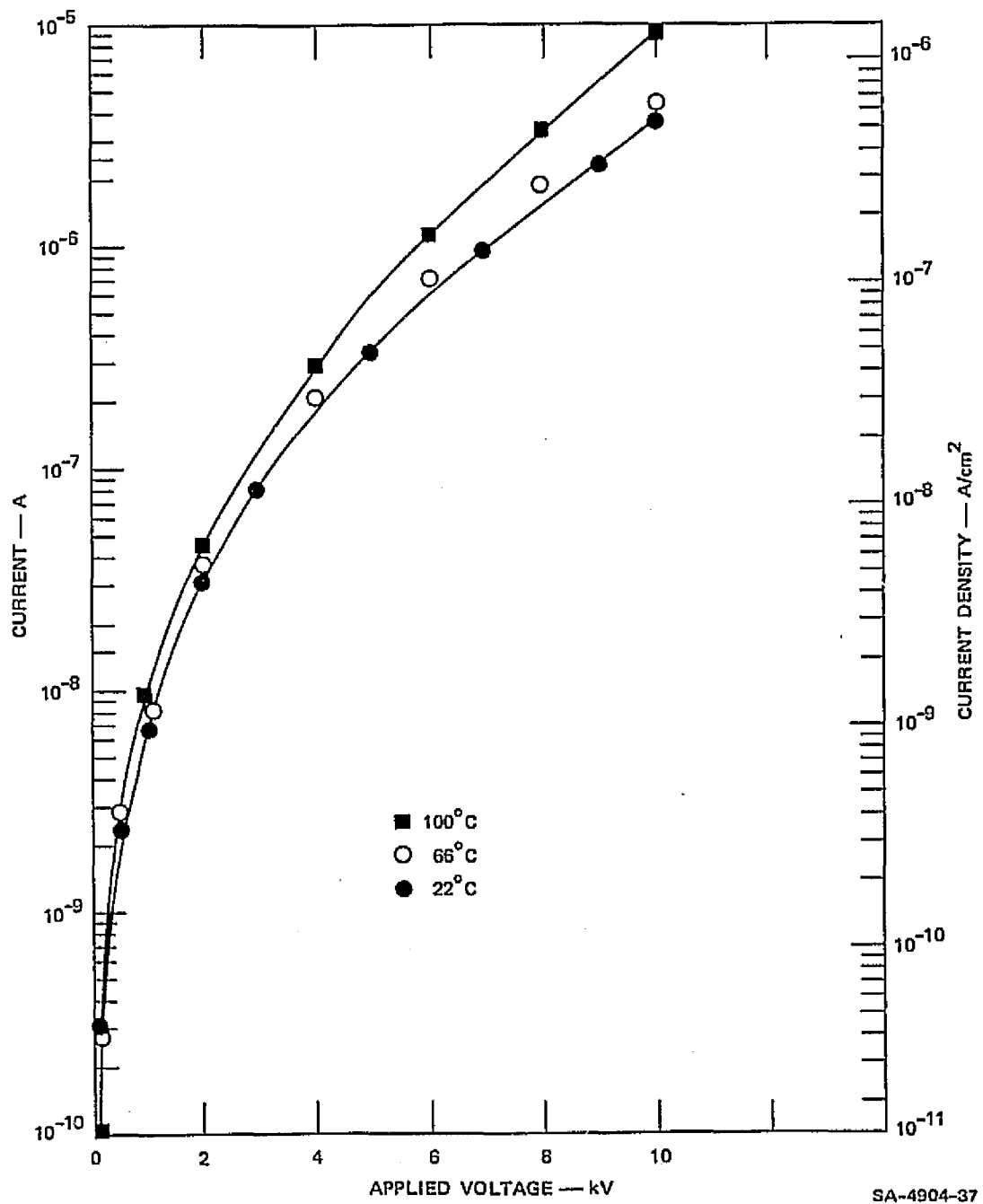

FIGURE 2-10 ILLUMINATED BULK-CURRENT DENSITY vs APPLIED VOLTAGE IN 5-mil KAPTON V AT 22, 66, AND 100°C

further on in this section. In addition, the results of short-term and 24-hour illuminated electron-beam tests of PVF₂ are described in Sections 3.3 and 4.2, respectively.

Illuminated surface-current tests were performed on Kapton V and PVF₂ samples and, as expected, the measured currents were dominated by photoemission effects. In tests on both PVF₂ and Kapton V the measured surface currents were between 7.6 (10⁻⁹) A and 9.4 (10⁻⁹) A with applied surface voltages between 100 V and 10 kV. These currents are the result of collection, by the positive surface electrode, of low-energy photoelectrons emitted from the region between the electrodes and, to a lesser extent, from the negative electrode.

The insulating gap between the surface electrodes is 0.15 cm wide, with a circumference of approximately 10 cm and therefore a gap area of 1.5 cm². Photoemission current densities of several nA/cm² are typical of many materials under solar illumination. The currents measured between the surface electrodes are therefore in good agreement with expected photoemission-current values.

In order to determine the optical wavelengths at which the bulk conductivities of PVF₂ and Kapton V samples are most enhanced, tests were performed with various optical bandpass filters inserted between the xenon illuminator and the test samples.

With the illuminator adjusted to produce a total incident power density of 100 mW/cm² at the sample location in the absence of bandpass filters, the actual power density produced with a particular bandpass filter introduced between the illuminator and the sample is a function of the filter's transmission characteristics as well as the amount of illuminator power within the filter's passband.

Figure 2-11 illustrates the actual incident power densities produced at the sample location as a function of wavelength for each of the nine bandpass filters used. These data were measured using a wideband pyroelectric radiometer.

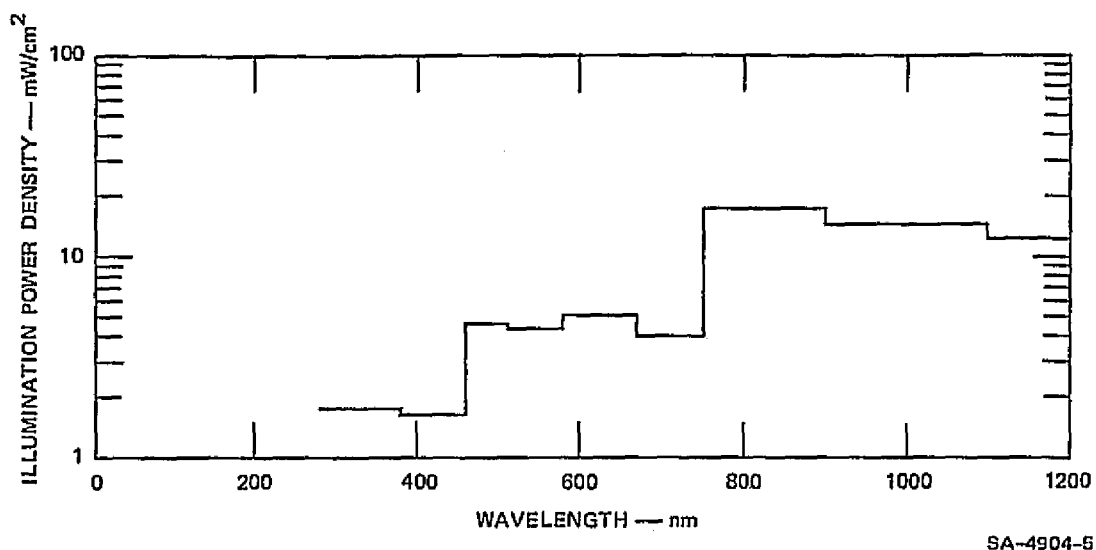

FIGURE 2-11 ILLUMINATION POWER DENSITIES vs WAVELENGTH WITH VARIOUS OPTICAL BANDPASS FILTERS

All normalized data illustrated in this section were calculated by dividing the actual measured currents in each passband by the relative power density in that passband taken from Figure 2-11. This simple normalization procedure assumes a linear relationship between illumination intensity and measured bulk current. The normalized bulk-current data therefore represent the currents that would be produced by 100 mW/cm^2 of incident illumination with wavelengths distributed within the indicated passband.

The normalized results of illuminated bulk-current measurements on 5-mil Kapton V at 22°C as a function of wavelength are shown in Figure 2-12 for two values of applied voltage. These data indicated that the greatest increase in bulk-current density in Kapton V is produced by illumination in the 500-to-580-nm wavelength range. Within the wavelength range tested (≈ 280 to 2000 nm) the bulk currents produced by wavelengths outside the 450-to-670-nm range were from one to almost four orders of magnitude lower than the values produced within that range. From the data in Figures 2-10, 2-11, and 2-12 it can be determined that illumination of the 5-mil Kapton V sample with 100 mW/cm^2 over the entire wavelength range of the xenon illuminator produced a measured bulk-current density

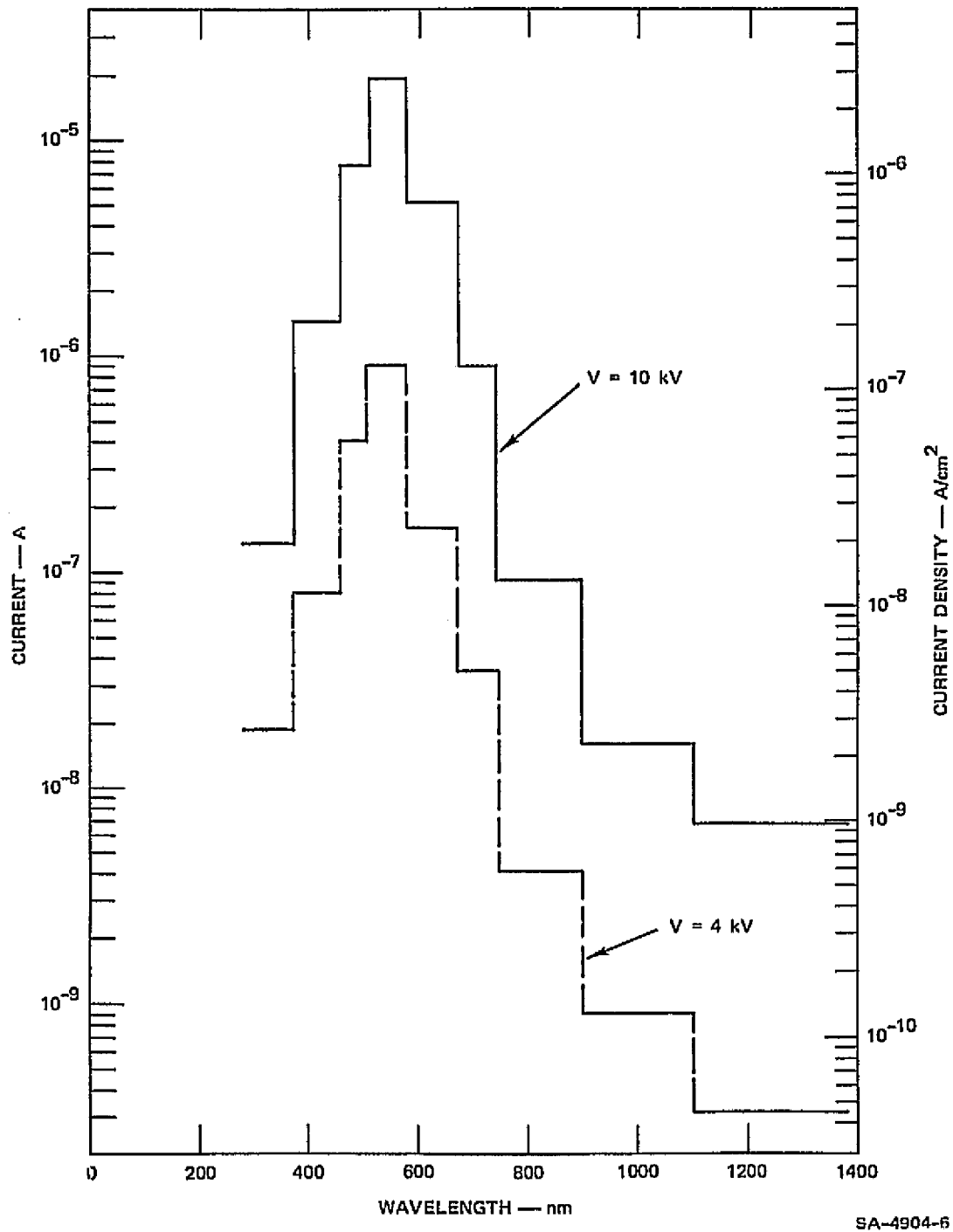

FIGURE 2-12 NORMALIZED ILLUMINATED BULK-CURRENT DENSITY vs WAVELENGTH IN 5-mil KAPTON V AT 22°C

only 3.7 times the measured (not normalized) bulk-current density of $5.2 (10^{-7}) \text{ A/cm}^2$ produced by only 5 mW/cm^2 of illumination concentrated in the 500-to-580-nm range.

Additional tests were performed to determine the relationship between the optical transmission properties of 5-mil Kapton V and the passbands of the optical filters used in the bulk conductivity tests. This was done by installing the wideband pyroelectric radiometer in place of the normal sample holder and measuring the intensity of illumination for each passband filter both with and without a 5-mil Kapton V sample suspended in the optical path.

The results of these tests as well as of similar tests performed on 2-mil PVF₂ are shown in Figure 2-13.

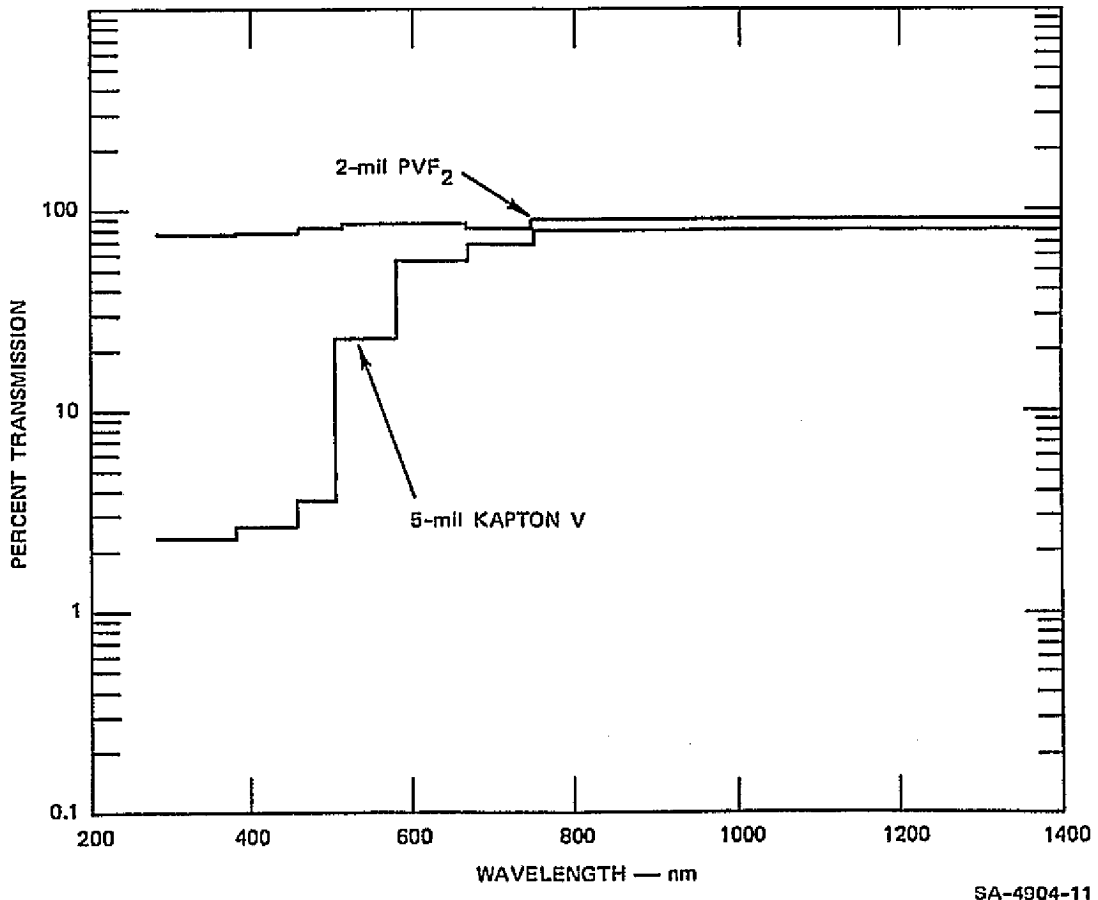

FIGURE 2-13 OPTICAL TRANSMISSION vs WAVELENGTH IN 5-mil KAPTON V AND 2-mil PVF₂

A comparison of Figures 2-12 and 2-13 reveals that the maximum bulk-current densities in Kapton V are produced by wavelengths in the transition region between high and low optical density.

In Figure 2-14 the results shown in Figure 2-12 with $V = 10$ kV

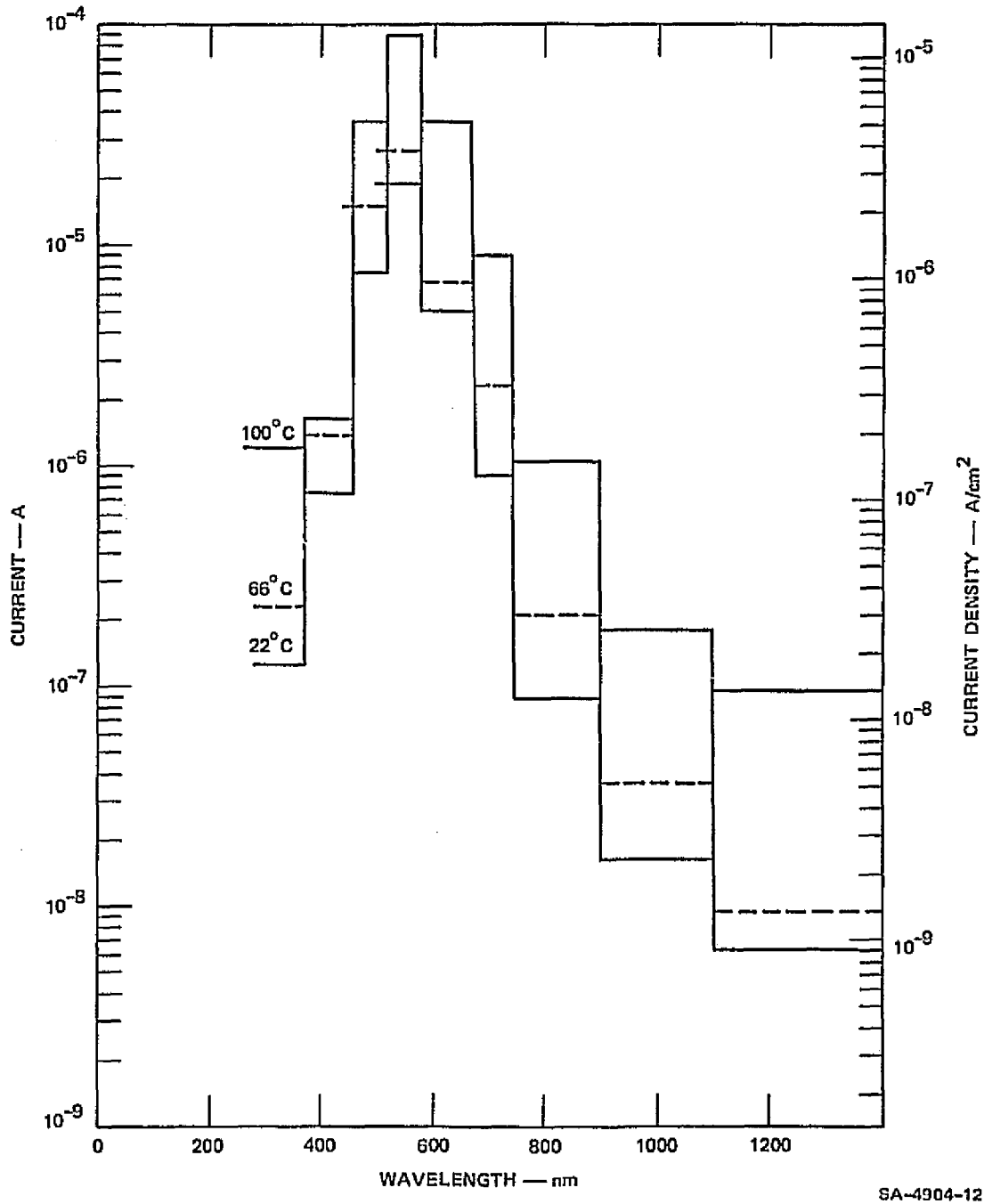

FIGURE 2-14 NORMALIZED ILLUMINATED BULK-CURRENT DENSITIES vs WAVELENGTH IN 5-mil KAPTON V AT 22, 66, AND 100°C. Applied voltage = 10 kV.

are combined with results from similar tests performed with sample temperatures of 66° and 100°C. As is expected, the bulk-current densities in each wavelength band increase with increased temperature. From Figure 2-14 the relative increase in bulk-current density produced by raising the sample temperature from 22°C to 100°C can be calculated, and the results of this calculation are illustrated in Figure 2-15. Earlier in this section it was noted that the effect of increasing temperature on the bulk-current density in Kapton V was significantly greater in the dark than with illumination. This result is confirmed by the data in Figure 2-15, from which it can be seen that the bulk-current density increases more with increased temperature at wavelengths where photoconduction is less pronounced.

As was discussed earlier, PVF₂ samples with front-surface metal electrodes were severely damaged by exposure to 100 mW/cm² of illumination. However, since the actual power densities in the bandpass filter tests are considerably lower, a series of such tests were performed using PVF₂ samples. The results of one set of tests on 2-mil PVF₂ at 22° with an applied voltage of 1 kV are shown in Figure 2-16. These results indicate that the maximum bulk currents in PVF₂ are produced by illumination wavelengths shorter than 470 nm.

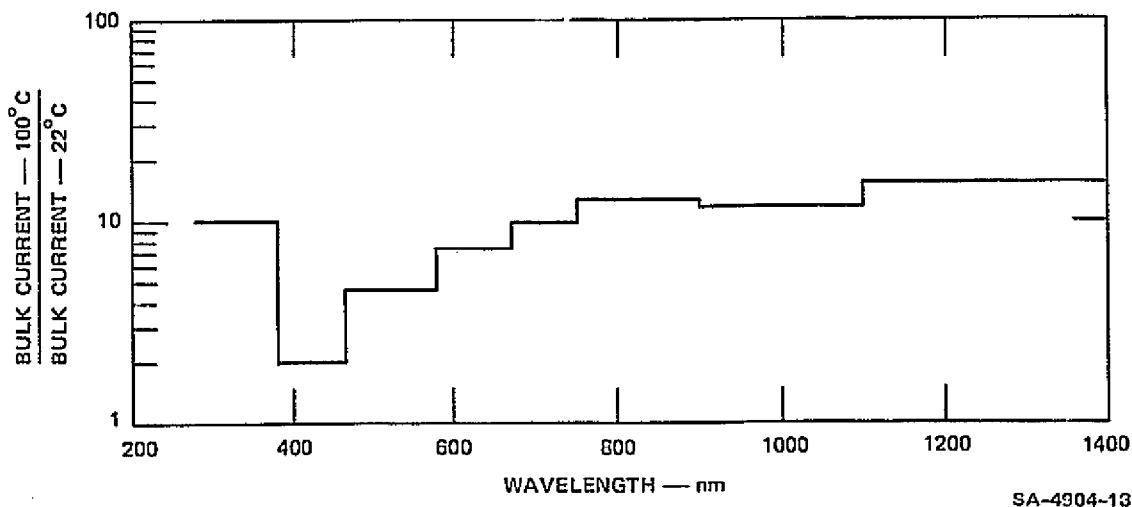

FIGURE 2-15 RATIOS OF BULK CURRENTS AT 100°C AND 22°C vs WAVELENGTH IN 5-mil KAPTON V

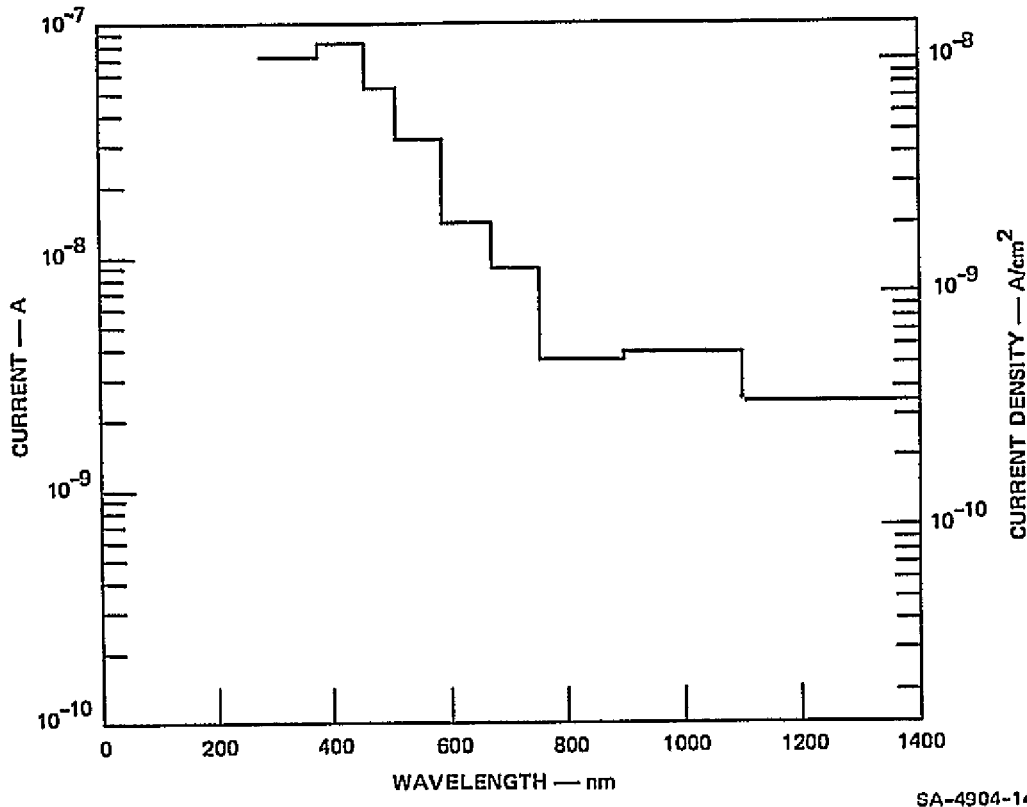

FIGURE 2-16 NORMALIZED ILLUMINATED BULK-CURRENT DENSITY vs WAVELENGTH IN 2-mil PVF₂ AT 22°C. Applied voltage = 1 kV.

As shown in Figure 2-13, 2-mil PVF₂ is relatively transparent to illumination in the wavelength range tested, but its optical density does begin to increase at shorter wavelengths.

The actual bulk-currents used to produce Figure 2-16 were measured 30 s after illumination was applied to the sample through each of the bandpass filters. In these particular tests on 2-mil PVF₂ at 22°C with a 1-kV applied voltage, the observed bulk currents after 30 s were relatively stable. In many cases, in tests in which higher applied voltages, higher temperatures, or thinner PVF₂ samples were used, the bulk currents were found to be increasing more or less rapidly after 30 s of illumination. The data shown in Figure 2-16 are therefore believed to be the most reliable in terms of the relationship between bulk current and illumination wavelength.

It is interesting to note that the normalized peak bulk-current density in the 380-to-470-nm band is $5.9 (10^1)$ times higher than the dark bulk-current density in 2-mil PVF₂ at 22°C with an applied voltage of 1 kV (see Figure 2-2). However, in 5-mil Kapton V at the same temperature and with the same applied voltage, the corresponding normalized peak bulk-current density in the 500-to-580-nm band is $3.9 (10^3)$ higher than the dark bulk current. Kapton V therefore appears to be considerably more photoconductive than PVF₂ in the wavelength range tested.

It is also interesting to note that, in a set of bandpass-filter tests at 22°C in which the short-circuit bulk current with no applied voltage was measured in a previously untested 1-mil PVF₂ sample, the peak normalized current density of $9.8 (10^{-11})$ A/cm² also occurred in the 380-to-470-nm range.

2.4 Results of Styrene Tests

In addition to tests on Kapton V and H, polyvinylidene fluoride, and FEP Teflon described elsewhere in this report, a number of special tests were performed on an opaque white material called Styrene. The reason for these tests was that Styrene was planned for use as an insulating coating on an electrical line that would be completely exposed to the space environment on a satellite system to be launched in the near future.

For use in these tests, two specially prepared samples of 6-mil-thick Styrene were supplied. Both dark and illuminated short-term bulk-current tests were performed on these samples after application of front- and rear-surface metal electrodes of the type shown in Figure 1-2. The results of the Styrene tests are shown in Figure 2-17. The bulk resistivities can be calculated from these results, if desired, using the equations given in Section 1.2. In these tests, the use of several lower applied voltages with a maximum applied voltage of 1 kV was dictated by the conditions in which Styrene was to be used.

The results of initial dark bulk-current tests at 22° and 100°C are shown as solid lines in the lower portion of the figure. In these, as

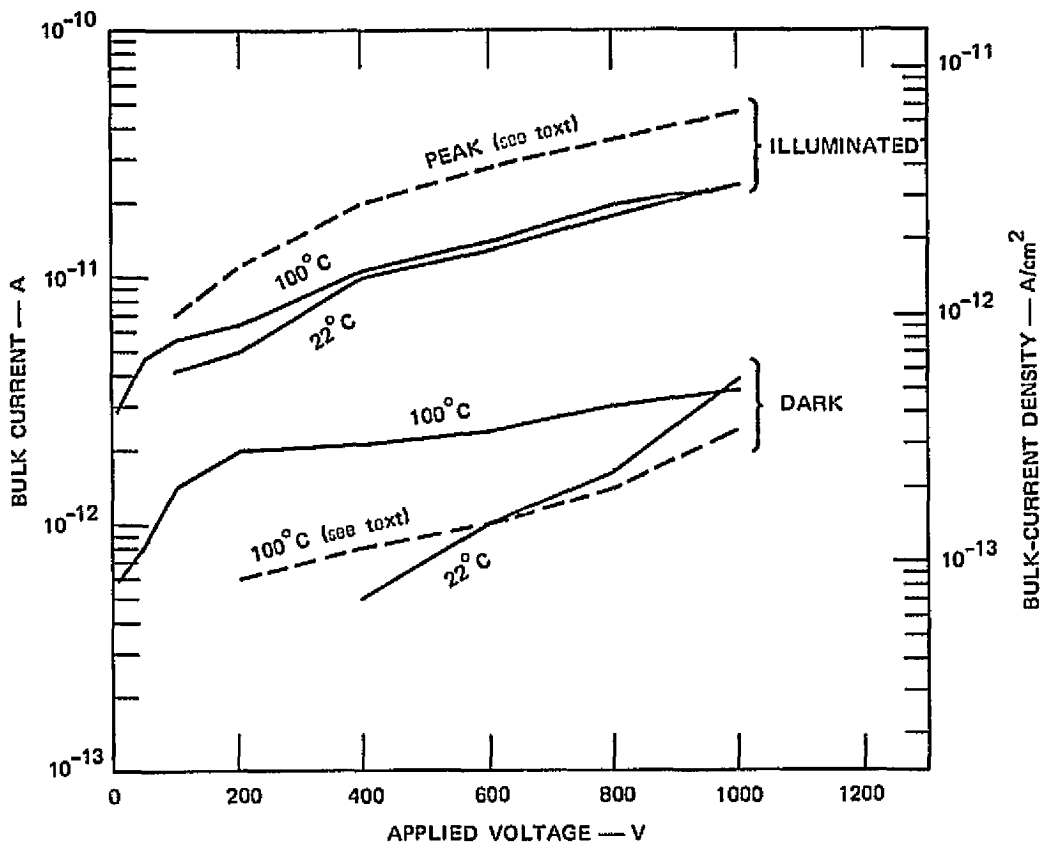

SA-4904-15

FIGURE 2-17 DARK AND ILLUMINATED BULK-CURRENT DENSITIES vs APPLIED VOLTAGE IN 6-mil STYLENE AT 22 AND 100°C

in all tests performed, Styrene behaved quite differently from other materials tested, in that the bulk-currents appeared to have completely stabilized within a few seconds of the application of the test voltages. The dark bulk-current densities in 6-mil Styrene are quite low and are comparable to those measured in 5-mil FEP Teflon samples under similar test conditions.

The results of illuminated bulk-current measurements at 22° and 100°C are shown as solid lines in the upper portion of Figure 2-17. It can be seen that there is little difference between the illuminated bulk-current densities measured at the two temperatures and also that the increase in bulk-current density caused by illumination is considerably less than has been measured in many other materials. It was

observed, while performing the illuminated tests, that the measured bulk currents immediately after exposure of the sample to illumination were slightly higher than the steady values shown as solid lines. The line labeled Peak in Figure 2-17 represents the peak values of these slightly higher currents. The combined data in Figure 2-17 indicate that the dark bulk resistivity of Styrene is comparable to that of other materials tested (e.g., Kapton V), but that the illuminated bulk resistivity is considerably higher.

After the performance of the illuminated bulk-current test at 100°C, the applied voltage was set at 100 V and the illuminator was left on for 6 hours with the sample maintained at 100°C. The illuminator was then turned off and the dark bulk currents were again measured, with the results shown as the dotted line labeled 100°C in the lower portion of Figure 2-17. These data indicate that the bulk insulating properties of Styrene may improve with heat and time in a vacuum.

To summarize, based on a limited number of tests, Styrene appears to be a relatively good dark bulk insulator and an excellent illuminated bulk insulator. The lowest values of dark bulk resistivity observed were $7.8 (10^{13})$ and $1.2 (10^{15})$ ohm-m at 10 V and 1000 V, respectively, at 100°C. The lowest values of illuminated bulk resistivity were $1.6 (10^{13})$ and $2 (10^{14})$ ohm-m, again at 10 V and 1000 V, respectively, at 100°C.

3. SHORT-TERM ELECTRON-BEAM TESTS

3.1 Summary and Comments

The results of short-term dark and illuminated electron-beam tests of Kapton V and PVF₂ are presented in detail in Sections 3.2 and 3.3. The dark bulk currents measured during the short-term electron-beam tests were strongly dependent on the order in which the tests were performed. In some tests, the polarities as well as the magnitudes of the observed currents were affected by previous test conditions. These effects are believed to be due to residual charge storage on the surface and in the bulk of the test samples. Exposure of the test samples to brief periods of illumination appeared to remove stored charge and return the samples to their original condition. For this reason, the results of short-term illuminated bulk-current tests were not noticeably affected by previous tests.

Each current measurement was performed after 60 s of sample exposure to an electron-beam having the indicated values of current-density and energy. A combination of effects such as charge-storage and secondary-electron emission produced a complex relationship between bulk-current densities measured in the dark and electron-beam current densities, particularly with lower-energy electron beams. During illumination, the relationship between beam-current densities and bulk-current densities was found to be more straightforward. In most dark and illuminated tests, the measured bulk-current densities in a given sample after 60 s of electron-beam exposure were approximately the same for all electron-beam energies above 4 to 6 keV and were equal to a relatively large fraction of the electron-beam current-density.

With a beam current density of 1.5 nA/cm^2 , the measured dark bulk-current densities with electrons of greater than 4 keV energy ranged from 0.2 nA/cm^2 in 5-mil Kapton V samples to approximately 0.5 and 1 nA/cm^2 in 2-mil and 0.25-mil PVF₂ samples, respectively. Under

illumination, the bulk-current density in Kapton V increased by a factor of 5, while the bulk-current densities in all thicknesses of PVF₂ remained relatively unchanged.

The dark bulk currents in both Kapton V and PVF₂ decreased by approximately an order of magnitude after 5 minutes of electron-beam exposure while the illuminated bulk-currents remained approximately constant with time. With electron-beam energies below approximately 2 keV the measured bulk currents were up to two orders of magnitude lower than at higher beam energies and generally increased with illumination and in thinner samples.

A comparison of the results of the short-term electron-beam tests and the results of the short-term metal-electrode tests indicates that several basic differences exist between these two test methods. For example, the results of the electron-beam tests, particularly of those performed in the dark at lower beam energies, point up some of the complex interactions that may occur between materials and their environment that are often not observable in conventional metal-electrode tests. In addition, the large currents available from a low-impedance voltage source in the metal-electrode tests are not always attainable in electron-beam tests where the maximum currents are limited by the total available electron-beam current. For the same reasons, the time required to reach electrostatic equilibrium may be considerably longer in electron-beam tests.

As discussed in Section 1.2, the test method used for the characterization of a particular material must therefore be chosen on the basis of the type of information desired and the nature of the application in which the material is to be used.

The results of additional metal-electrode and electron-beam tests of Kapton V and PVF₂ as well as of Kapton H and FEP Teflon are compared in Section 4.1.

3.2 Results of Short-Term Dark Electron-Beam Tests

The data presented in this section were obtained using the electron-beam test setup shown in Figure 1-2.

During the performance of initial dark and illuminated electron-beam tests on 5-mil Kapton V, an important difference between these two types of tests became obvious. In the dark electron-beam tests, with a constant incident electron-beam density, the magnitude of the measured bulk current at a specific electron-beam energy depends strongly on the beam energies used for preceding test points. An example of this "hysteresis" effect is shown in Figure 3-1. It should be noted that the left-hand current scale on this figure is not logarithmic but linear.

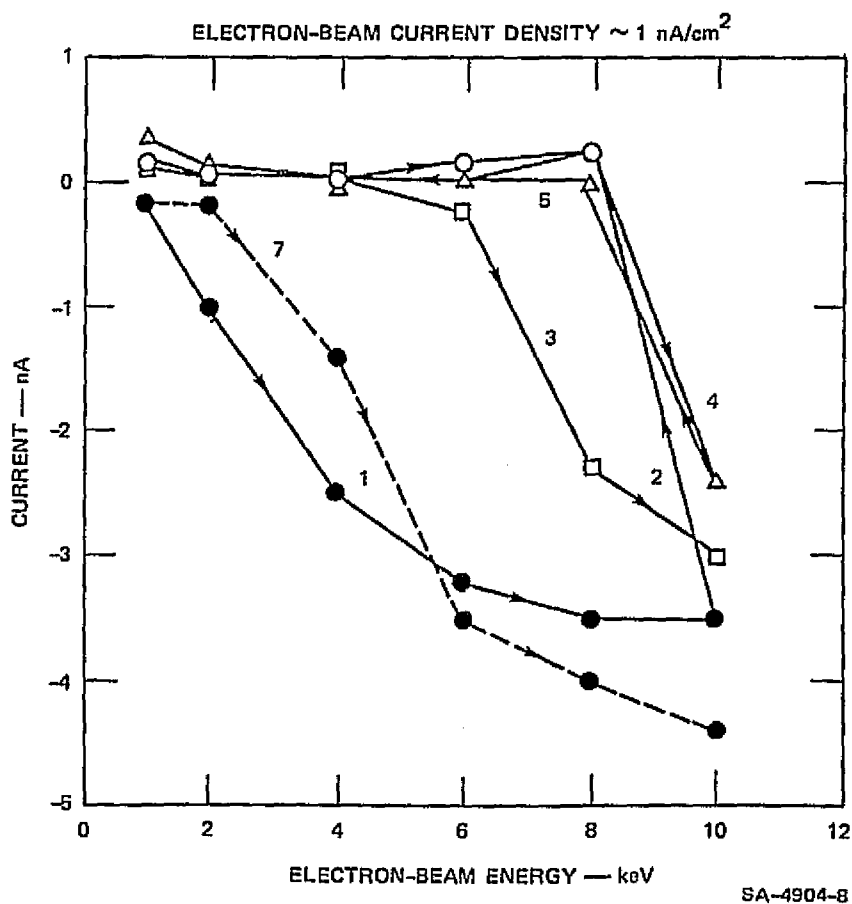

FIGURE 3-1 EFFECTS OF TEST SEQUENCE ON DARK BULK CURRENTS IN 5-mil KAPTON V AT 22°C

The initial measured currents obtained by stepping the incident electron-beam energy up from 1 keV to 10 keV, while maintaining the incident beam current constant at 1 nA/cm^2 , are connected by the line labeled 1. Each of these currents was measured after the incident beam had remained at the indicated energy for 60 s.

The line labeled 2 shows the currents obtained as the beam energy was stepped down from 10 keV. It can be seen that Curves 1 and 2 are quite different. Additional tests indicated that after stepping through the entire energy range several times in the dark, the results became similar in either direction (as shown in Curves 4 and 5) and the "hysteresis" effect was no longer evident. However, after the completion of Test 5, the electron beam was turned off for 60 s while the sample was exposed to 100 mW/cm^2 of illumination. The illuminator was then turned off and the dark electron-beam test was repeated, yielding the results shown by Curve 7. The results of this and other tests indicate that short periods of illumination tend to "erase" the sample and return it to near its original state. The results shown in Figure 3-1 were obtained with Kapton V samples, and similar effects were observed using Kapton H and polyvinylidene fluoride samples. In additional tests in which the samples were illuminated throughout the test sequence, the hysteresis effect did not occur.

The results shown as Curves 1 and 2 in Figure 3-1 can be qualitatively explained by sample surface potential considerations. With incident electron energies above 2 keV, the dark equilibrium surface potential of Kapton V is determined mainly by the sample's secondary-electron emission characteristics and is consequently approximately 2 kV less than the electron-beam accelerating voltage. Therefore, as the electron-beam energy is increased (as in Curve 1), the equilibrium surface potential becomes more and more negative and the bulk displacement currents necessary to achieve equilibrium are also negative. Although equilibrium may not be reached after 60 s, the displacement and leakage currents are both negative and thus produce a negative value of measured bulk current. On the other hand, as the electron-beam energy is decreased (as in Curve 2), the equilibrium surface potential

becomes more and more positive with respect to previous values. The required displacement currents are therefore also positive, as shown in Figure 3-1. In addition, the time required to discharge the sample surface by decreasing the electron-beam energy may be considerably longer than the time required to charge the sample by increasing the electron-beam energy, since lower-energy electrons cannot readily reach the highly charged sample until bulk leakage through the sample has sufficiently reduced its surface potential. This long discharging time constant may also be responsible for the convergence of the data obtained in subsequent tests.

This simplified argument is capable of explaining many aspects of the measured data; however, the actual physics involved in producing the data shown in Figure 3-1 is considerably more complex. For example, experiments indicate that with an incident current density of 1 nA/cm^2 , it is unlikely that an equilibrium potential of approximately -8 kV could be reached within the 6 minutes required to obtain the data illustrated by Curve 1. The reduction of the incident electron-beam energy from 10 keV to 8 keV would therefore not result in a reduction in surface potential as suggested by the simplified theory, nor in a positive displacement current as predicted and as was actually measured, as shown in Figure 3-1.

In order to adequately explain the observed data it is therefore necessary to consider that charge storage is not confined to the front and rear surfaces of the sample alone. Even in the case of the metal-electrode tests described in Section 2, internal charge storage and bulk polarization produce results that differ considerably from those predicted by a simple capacitor model. In the case of electron-beam tests, the charge distribution within the bulk of the sample may be quite complex and may persist for long periods, particularly in materials having a high bulk resistivity. The distributions of charge on the surface and within the bulk of a given test sample are a result of the time history and conditions of previous tests and can affect the magnitudes as well as polarities of currents measured in subsequent tests.

As is shown by Curve 7 in Figure 3-1, it is possible to at least partially erase stored charge in Kapton V by exposing the sample to illumination for a brief period. The equilibrium surface potential of most materials under solar illumination is dictated by photoemission from exposed surfaces and is usually a few volts positive in the absence of high incident charged-particle current densities. Sample illumination therefore acts to eliminate residual negative surface charge from previous tests. In addition, the bulk conductivity of Kapton increases by many orders of magnitude under illumination, thereby allowing more rapid dissipation of internally trapped charge. It is possible that similar results could be obtained by allowing sufficient time between tests for surface and bulk charge to decay, but charge-decay time constants of several years have been reported for many dielectrics.

As was noted earlier, continuous photoemission from sample surfaces as well as increased bulk conductivity due to continuous illumination of test samples during each test sequence appeared to eliminate hysteresis effects from measured data of the type presented in Section 3.3.

In an attempt to eliminate discrepancies due to charge storage effects, the test results illustrated in Figures 3-2 through 3-6 were obtained by illuminating the test samples for 60 s several minutes before the start of each test sequence, and by stepping through the various values of incident beam energy in a monotonically increasing order.

The results of dark electron-beam tests of 5-mil Kapton V at 22, 66, and 100°C with an electron-beam current density of 1.5 nA/cm^2 are shown in Figure 3-2. These data indicate that the effect of increasing temperature on the measured bulk current is reduced at higher beam energies, and that above approximately 6 keV the measured bulk current levels off to a relatively constant fraction of the electron-beam current.

In order to determine the effect of electron-beam current density on the measured bulk current an additional test was performed on 5-mil Kapton V at 22°C with a current density of 15 nA/cm^2 . The results of

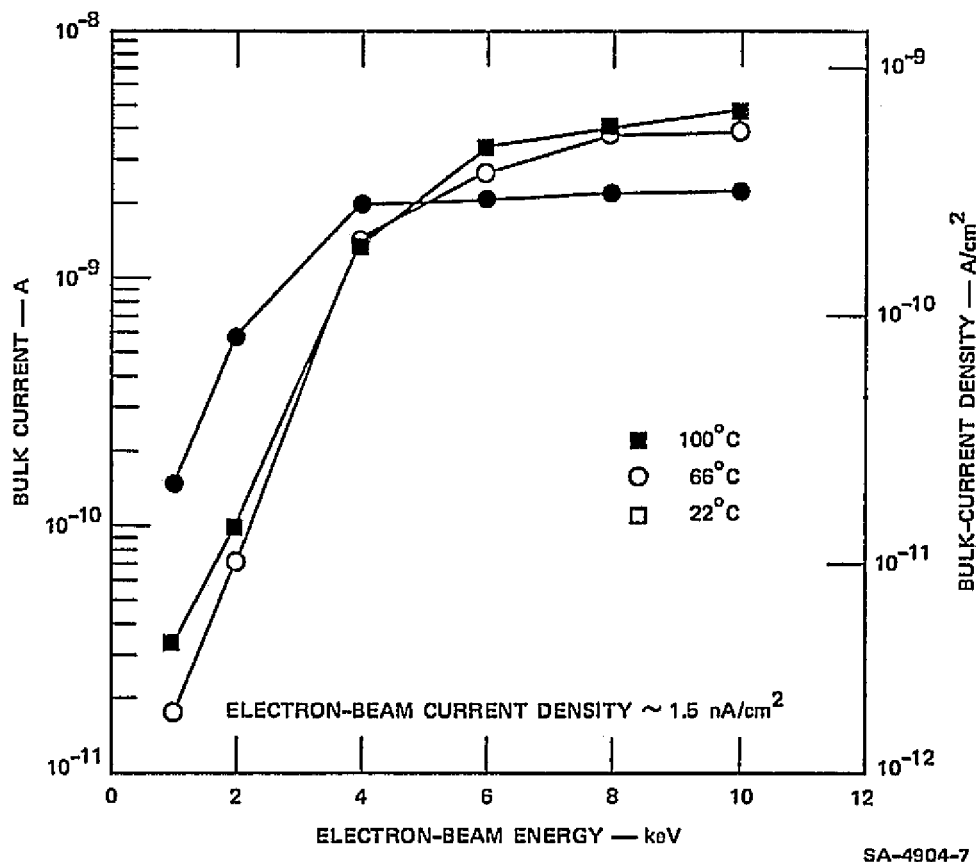
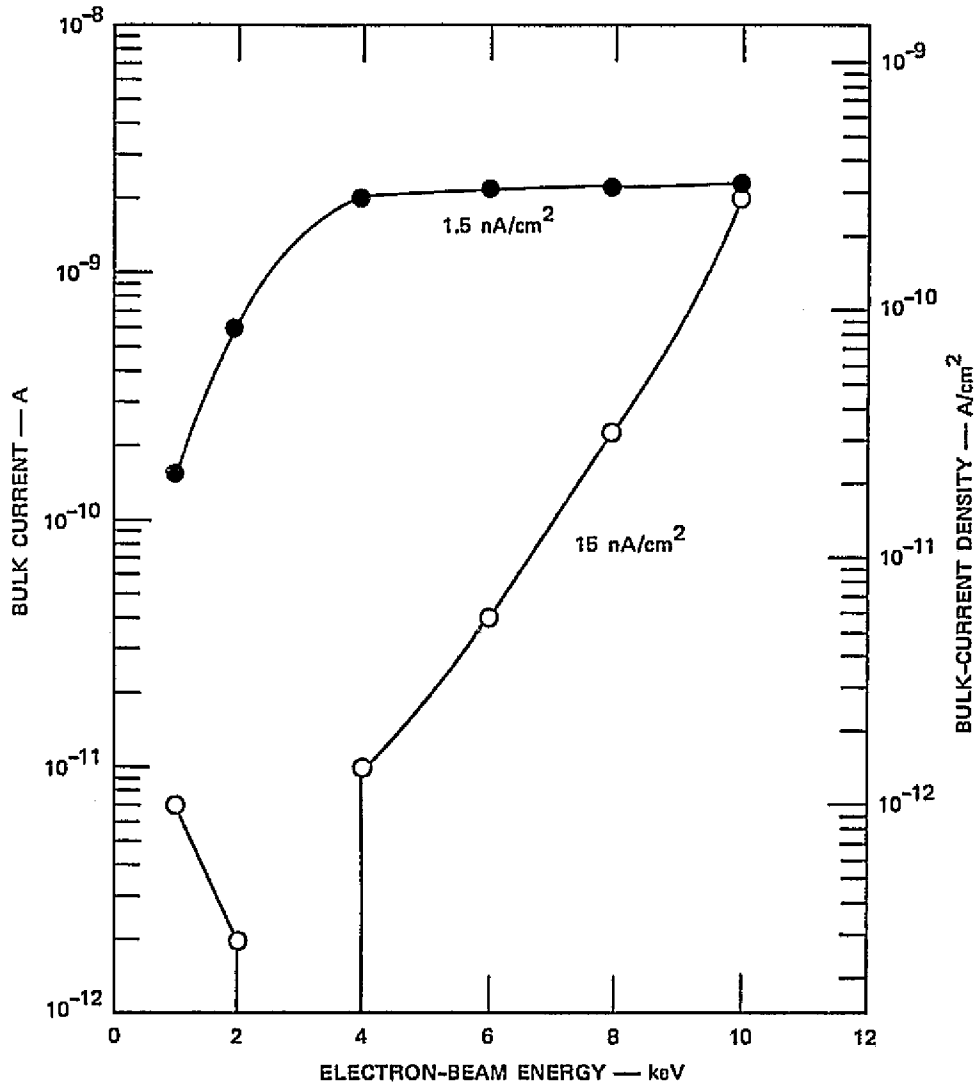

FIGURE 3-2 DARK BULK-CURRENT DENSITIES vs ELECTRON-BEAM ENERGY IN 5-mil KAPTON V AT 22, 66, AND 100°C

this test as well as the 1.5 nA/cm² results at 22°C from Figure 3-2 are shown in Figure 3-3. It can be seen that the results obtained at 15 nA/cm² are quite different from those obtained at 1.5 nA/cm², both in the shape of the plotted curve and in that the measured bulk currents after 60 s of exposure to 1-keV and 2-keV electron beams were of positive rather than negative polarity. Tests were also performed using other electron-beam current densities ranging from 0.5 to 100 nA/cm², and in these tests it was found that the relationships between beam-current density and bulk-current density measured after 60 s of electron-beam exposure were quite complex. In subsequent tests in which samples were simultaneously exposed to the electron beam and to illumination (as reported in Section 3.3), the results were found to be much more straightforward.



SA-4904-16

FIGURE 3-3 DARK BULK-CURRENT DENSITIES vs 1.5 nA/cm² AND 15 nA/cm² ELECTRON-BEAM ENERGIES IN 5-mil KAPTON V AT 22°C

Results of dark electron-beam tests on 2-mil PVF₂ at 22, 66, and 100°C with a beam density of 1.5 nA/cm² and at 22°C with a beam density of 15 nA/cm² are shown in Figure 3-4. The 1.5-nA/cm² results obtained with 2-mil PVF₂ at all three temperatures are similar to those obtained with 5-mil Kapton V, although the bulk currents at beam energies above 4 keV are slightly higher. Also, as with Kapton V, with 15 nA/cm² of 1-keV and 2-keV electrons, the measured bulk currents are positive.

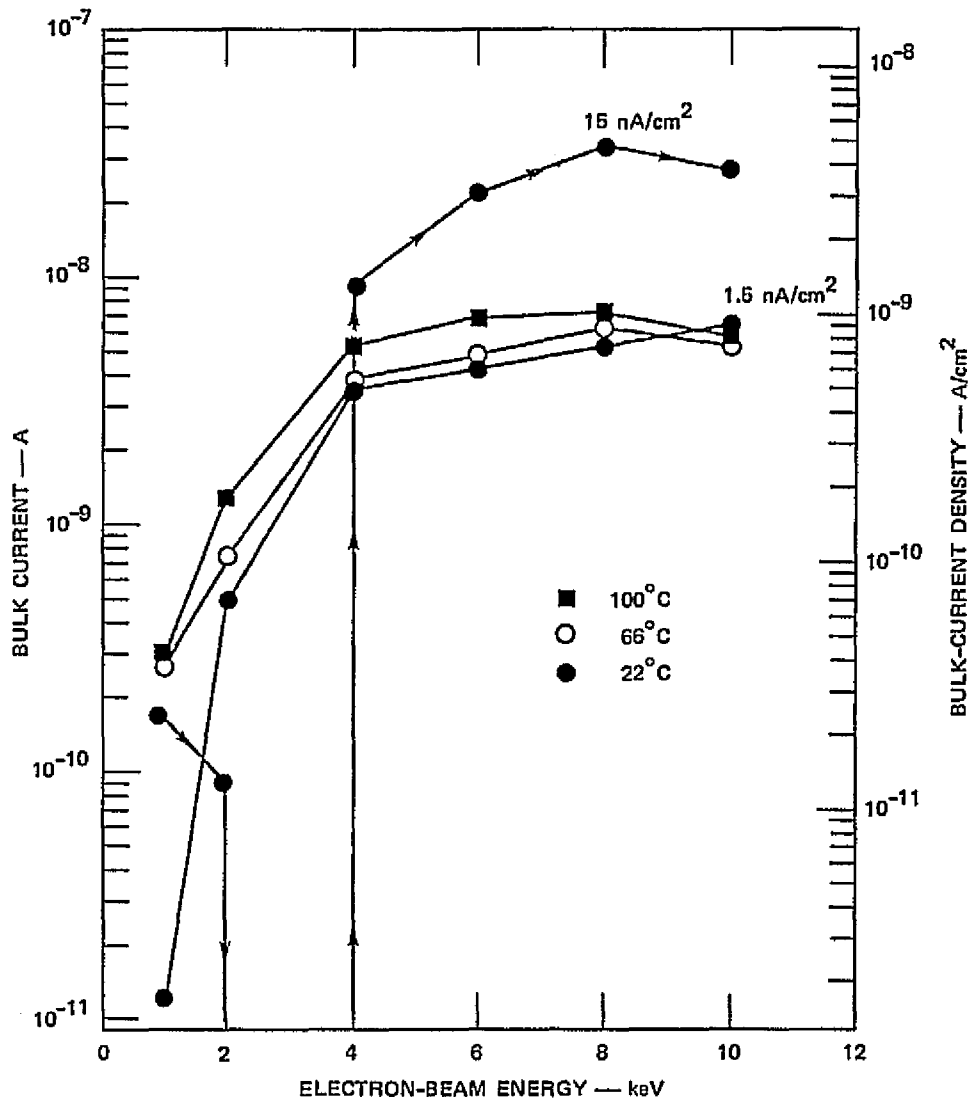

SA-4904-17

FIGURE 3-4 DARK BULK-CURRENT DENSITIES vs ELECTRON-BEAM ENERGY IN 2-mil PVF₂ AT 22, 66, AND 100°C

With energies of 4 keV and above, the 15-nA/cm² results are more similar to those measured with 1.5 nA/cm², although somewhat higher, as would be expected.

The results of 1.5-nA/cm² tests at 22, 66, and 100°C on 1-mil and 0.25-mil PVF₂ samples are shown in Figures 3-5 and 3-6, respectively. A comparison of Figures 3-3, 3-4, and 3-5 indicates that the measured bulk currents generally reach their approximate maximum values with

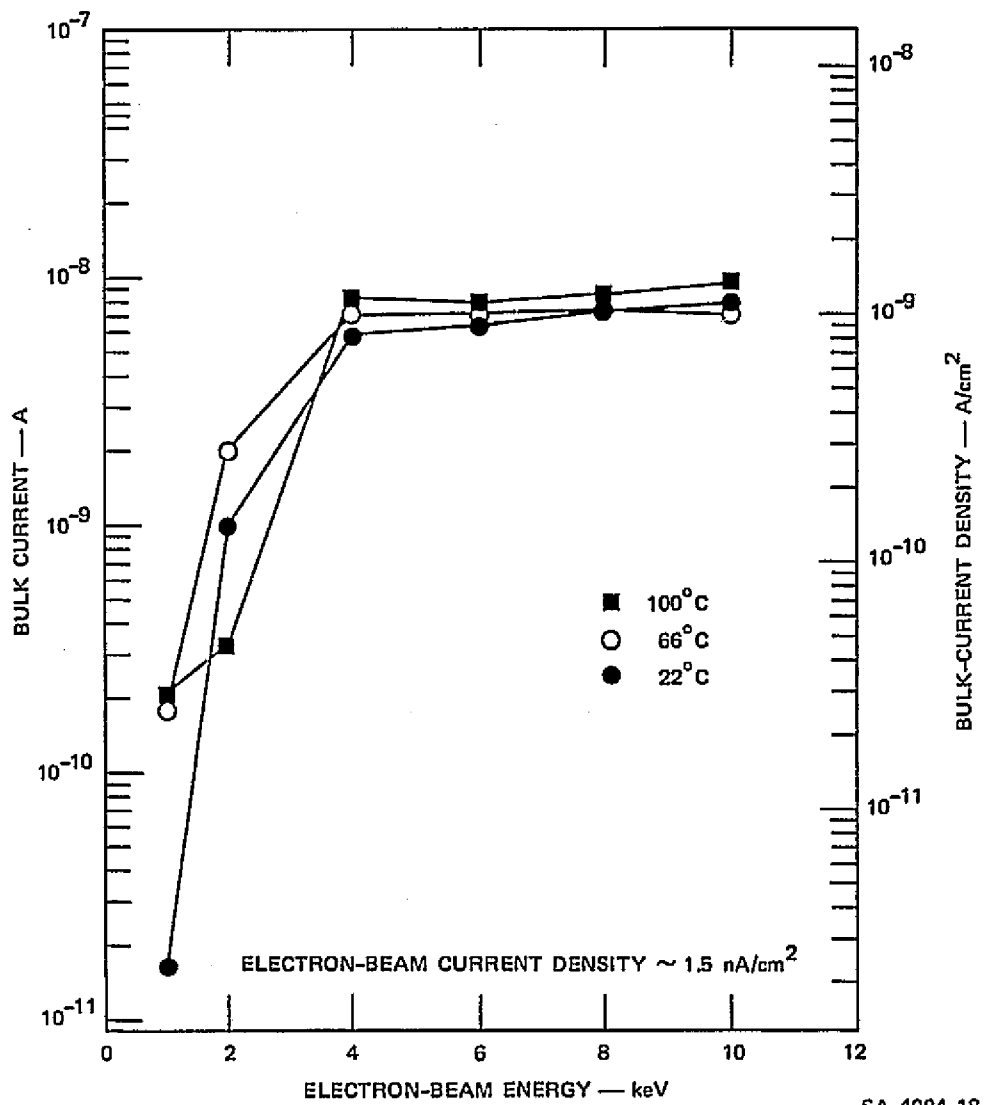
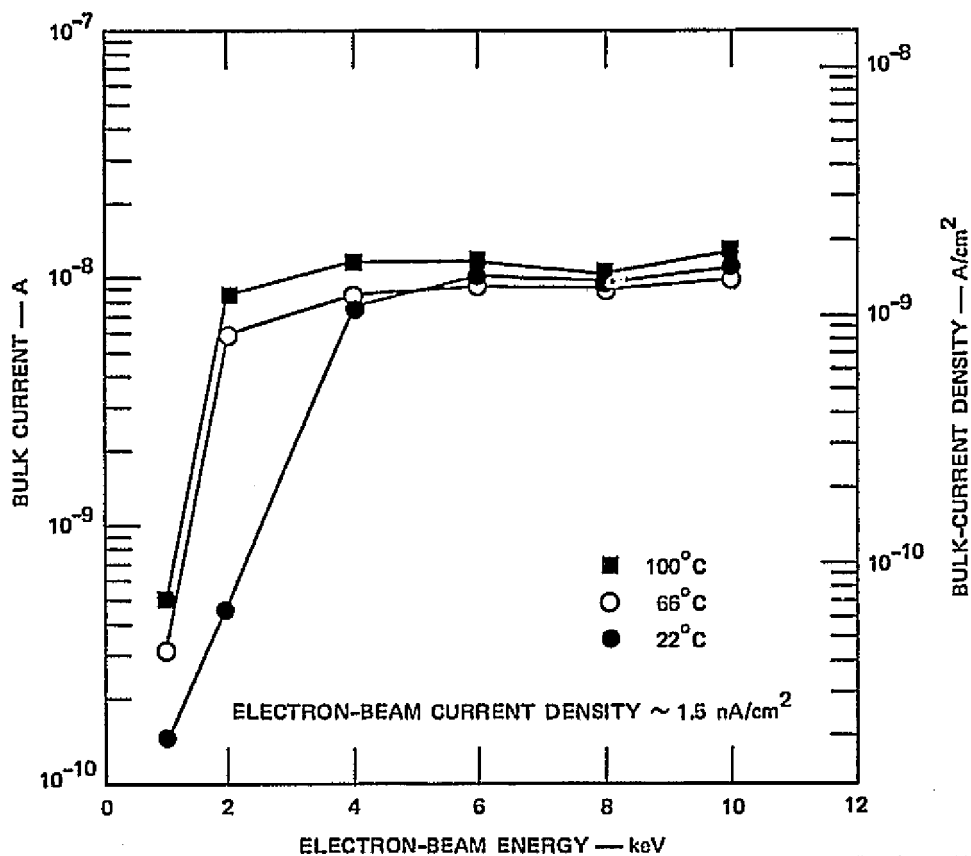

FIGURE 3-5 DARK BULK-CURRENT DENSITIES vs ELECTRON-BEAM ENERGY
 IN 1-mil PVF₂ AT 22, 66, AND 100°C



SA-4904-19

FIGURE 3-6 DARK BULK-CURRENT DENSITIES vs ELECTRON-BEAM ENERGY IN 0.25-mil PVF₂ AT 22, 66, AND 100°C

lower beam energies in thinner PVF₂ samples, and that these maximum bulk currents are slightly higher in thinner samples as well as at higher temperatures.

3.3 Results of Short-Term Illuminated Electron-Beam Tests

The results reported in this section were obtained using the electron-beam test setup shown in Figure 1-2. The indicated bulk currents were each measured with the samples simultaneously exposed to a power density of 100 mW/cm² from the xenon illuminator and electron beams of various energies and current densities from the multipactor electron gun. Each data point was obtained after 60 s of electron-beam exposure at the indicated energy and current density and after 30 s of illumination.

The samples were shielded from the electron beam and from illumination for approximately 30 s after each bulk-current measurement to allow the electron-beam energy and current density to be readjusted for the next measurement.

Figure 3-7 illustrates the illuminated bulk currents measured in 5-mil Kapton V at 22°C with electron-beam current densities of 1.5 and 15 nA/cm². Data from Figure 3-3 are reproduced in Figure 3-7 for comparison of dark and illuminated bulk currents. The illuminated bulk currents in Figure 3-7 are considerably higher than the dark bulk currents, and with electron-beam energies above 4 keV are approximately equal to the total electron-beam current incident on the measured area at the center of the sample. In addition, unlike the results obtained in the dark electron-beam tests, at higher beam energies a ten-fold increase in the beam current density produces a corresponding ten-fold increase in the illuminated bulk current.

This relationship was further explored in an additional series of tests, the results of which are shown in Figure 3-8. These data indicate that, with a beam energy of 10 keV, the illuminated bulk current after 60 s of electron-beam exposure is linearly proportional to the beam current density. However, as the beam energy is decreased, the illuminated bulk current becomes a smaller fraction of the total incident current, particularly at higher beam current densities.

Figure 3-9 illustrates that in 5-mil Kapton V, the illuminated bulk current with an incident beam current density of 1.5 nA/cm² is virtually unaffected by raising the sample temperature from 22°C to 66 or 100°C.

Data of the type plotted in Figure 3-7 for 5-mil Kapton V are given in Figure 3-10 for 2-mil PVF₂. As was observed in Kapton V, the positive bulk currents produced in the dark by 1- and 2-keV electrons at a current density of 15 nA/cm² became negative when the PVF₂ sample was illuminated. Unlike the results observed in Kapton V, however, the bulk currents produced in 2-mil PVF₂ by beam energies greater than 4 keV do not increase significantly under sample illumination. In fact, the dark bulk currents in 2-mil PVF₂ at higher beam energies are considerably higher

than those in 5-mil Kapton V, while the illuminated bulk currents are two to four times lower.

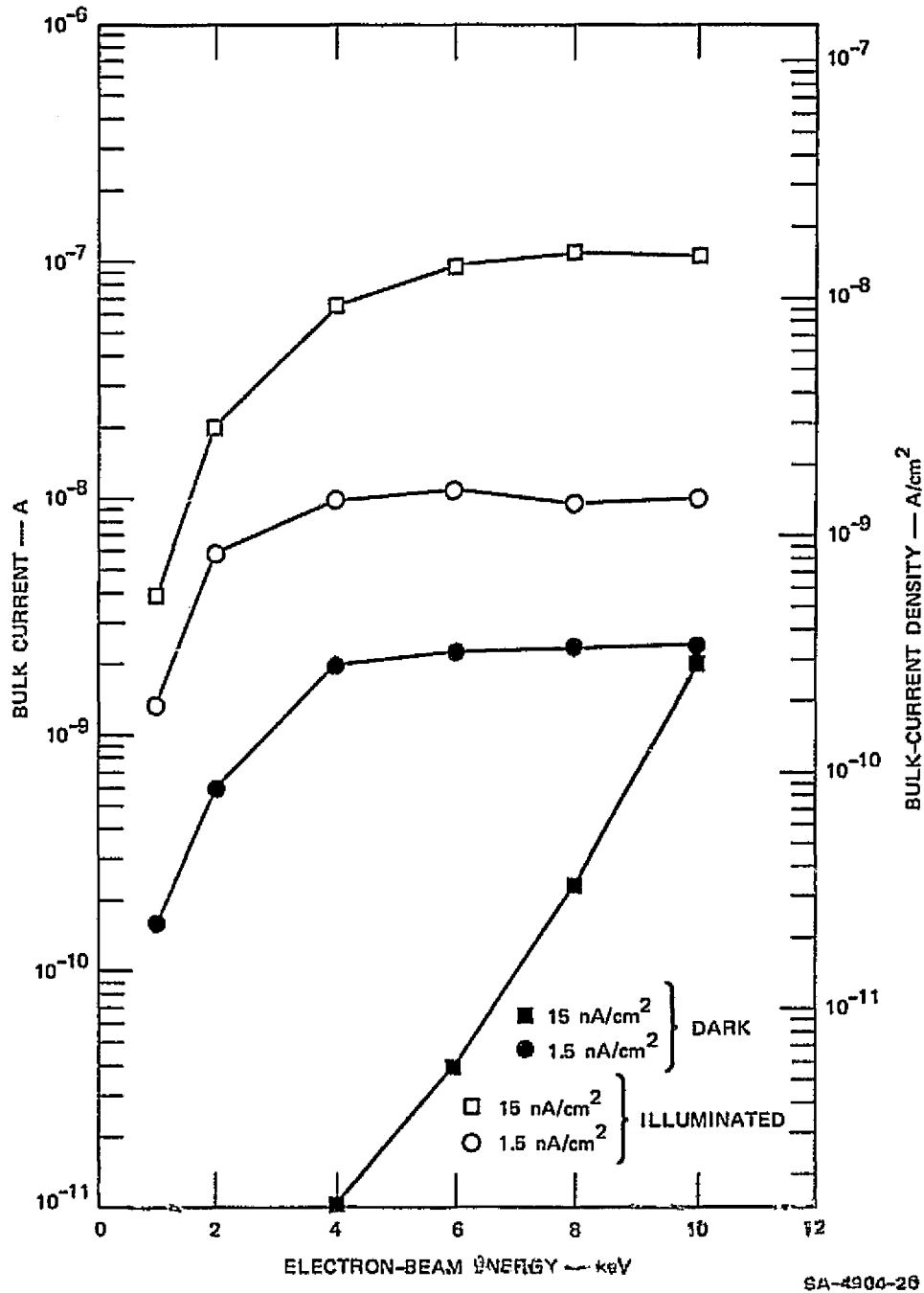

FIGURE 3-7 DARK AND ILLUMINATED BULK-CURRENT DENSITIES vs 1.5 nA/cm² AND 15 nA/cm² ELECTRON-BEAM ENERGIES IN 5-mil KAPTON V AT 22°C

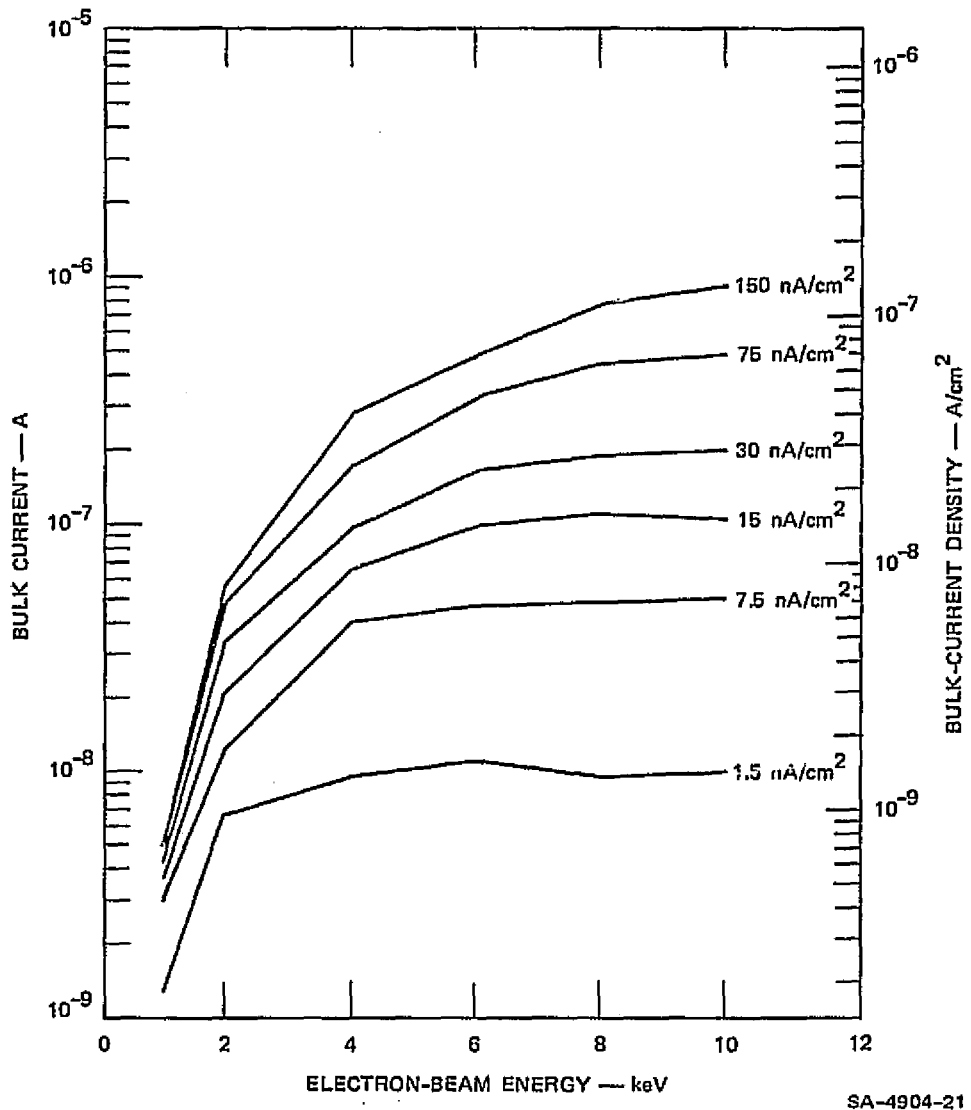
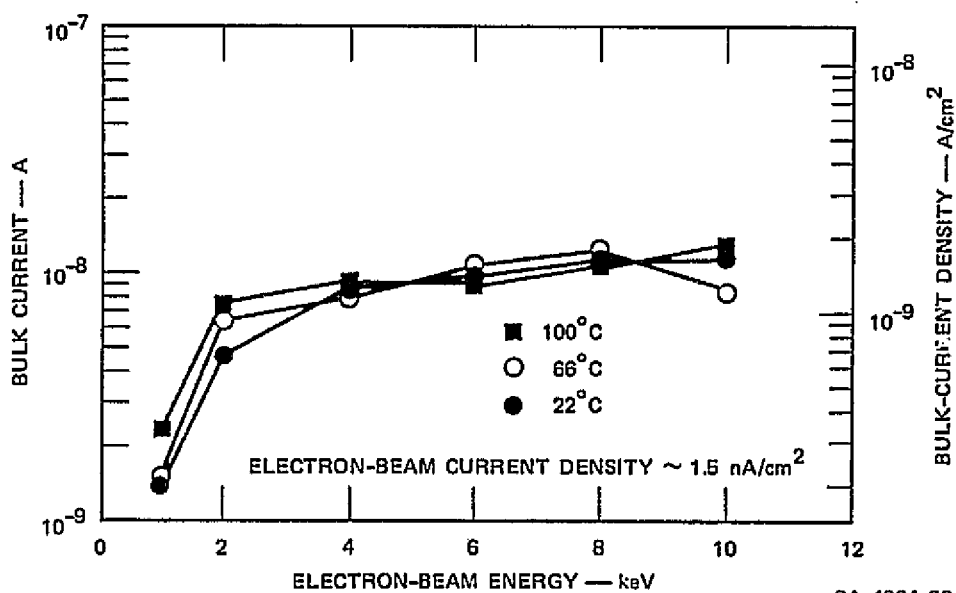

FIGURE 3-8 ILLUMINATED BULK-CURRENT DENSITIES vs ELECTRON-BEAM ENERGY IN 5-mil KAPTON V AT 22°C WITH SEVERAL BEAM-CURRENT DENSITIES



SA-4904-22

FIGURE 3-9 ILLUMINATED BULK-CURRENT DENSITIES vs ELECTRON-BEAM ENERGY IN 5-mil KAPTON V AT 22, 66, AND 100°C

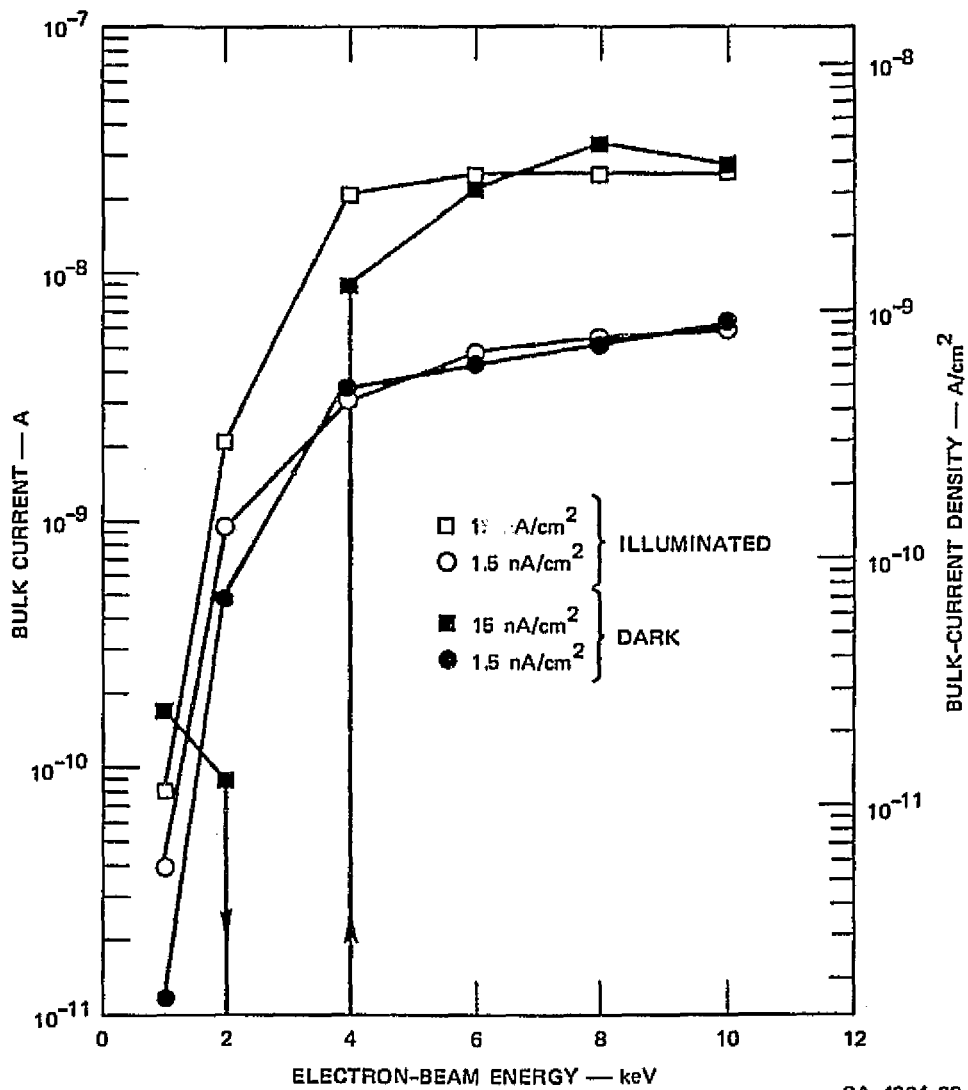

FIGURE 3-10 DARK AND ILLUMINATED BULK-CURRENT DENSITIES vs 1.5 nA/cm² AT 15 nA/cm² ELECTRON-BEAM ENERGIES IN 2-mil PVF₂ AT 22°C

The illuminated bulk currents measured at 22, 66, and 100°C with an electron-beam current density of 1.5 nA/cm^2 in 2-, 1-, and 0.25-mil PVF_2 samples are shown in Figures 3-11, 3-12, and 3-13. A slight increase in illuminated bulk current with increased temperature at higher beam energies is suggested in the 2-mil PVF_2 data, but such a relationship is not evident in the data from 1-mil and 0.25-mil PVF_2 samples.

A comparison between the illuminated PVF_2 bulk currents reported in this section and the dark PVF_2 bulk currents reported in Section 3.2

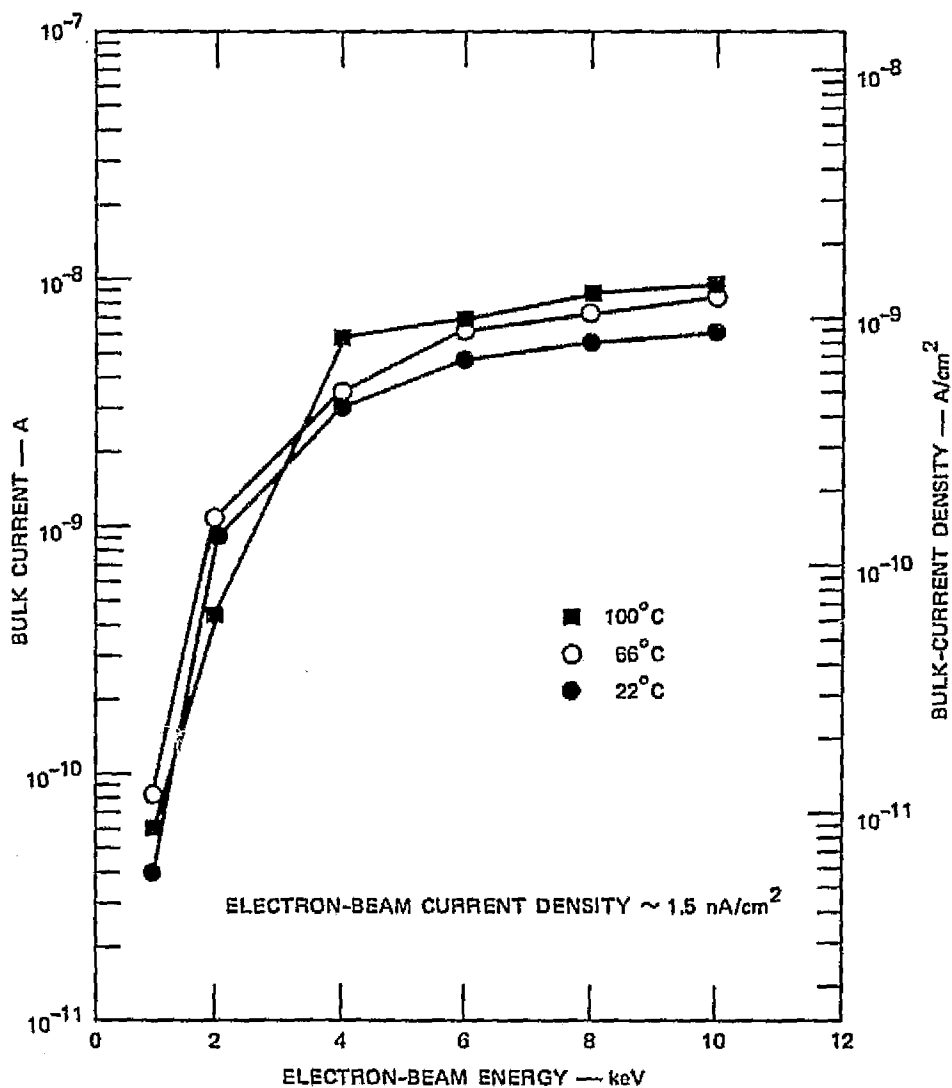

FIGURE 3-11 ILLUMINATED BULK-CURRENT DENSITIES vs ELECTRON-BEAM ENERGY IN 2-mil PVF_2 AT 22, 66, AND 100°C

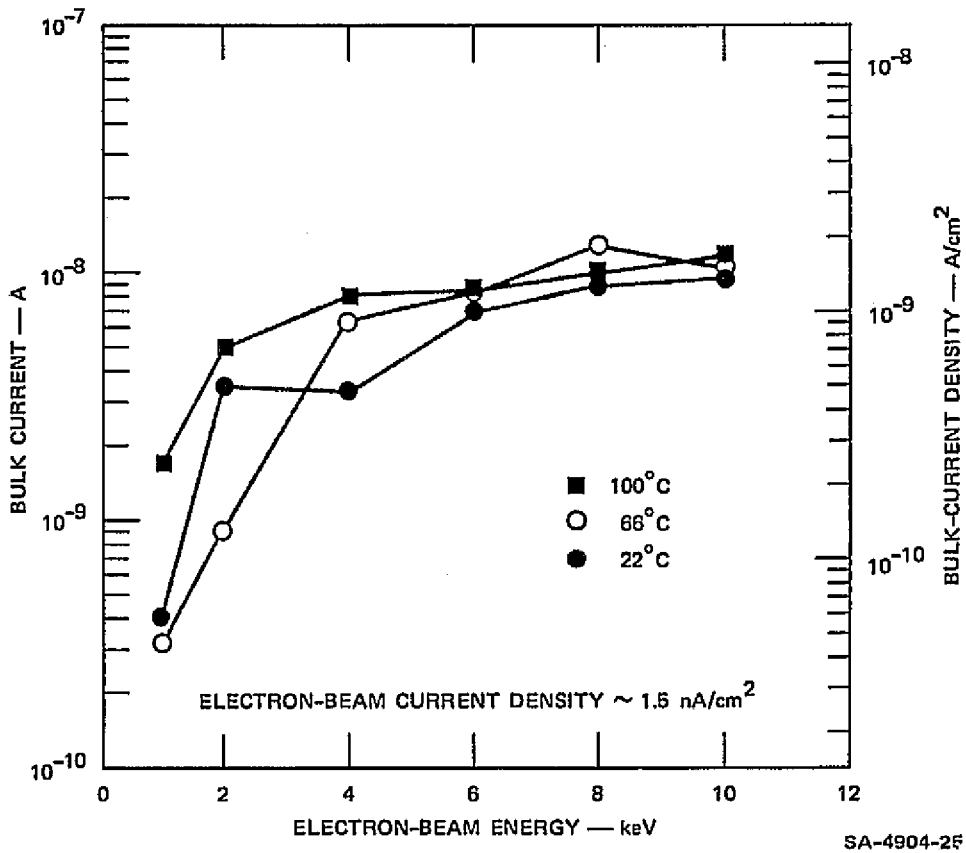
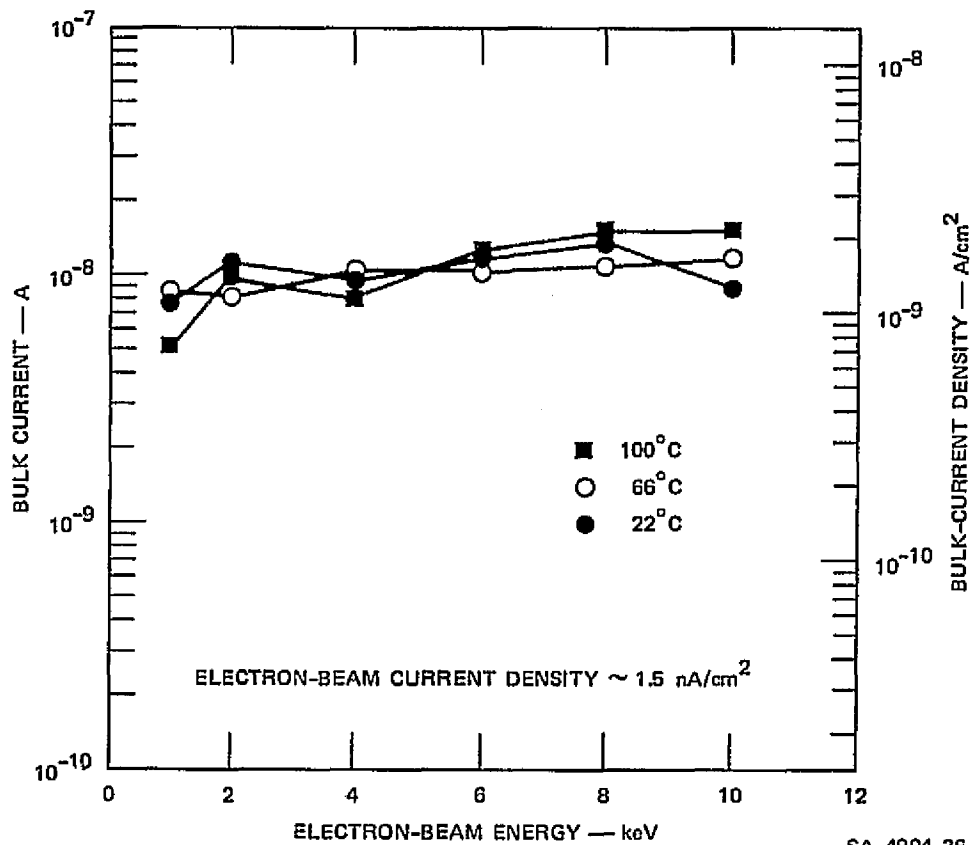

FIGURE 3-12 ILLUMINATED BULK-CURRENT DENSITIES vs ELECTRON-BEAM ENERGY IN 1-mil PVF₂ AT 22, 66, AND 100°C



SA-4904-26

FIGURE 3-13 ILLUMINATED BULK-CURRENT DENSITIES vs ELECTRON-BEAM ENERGY IN 0.25-mil PVF₂ AT 22, 66, AND 100°C

indicates that with an incident electron-beam current density of 1.5 nA/cm^2 , the effects of illumination on bulk currents in PVF₂ are relatively minor. These illumination effects include a slight increase in bulk current at higher beam energies in all thicknesses of PVF₂, and increased bulk currents at lower beam energies in 0.25-mil PVF₂ samples.

4. 24-HOUR ILLUMINATION TESTS

4.1 Summary and Comments

Previous tests of Kapton H samples indicated that long-term changes in the conductivity properties of Kapton H could result from extended periods of sample illumination. In order to verify this phenomenon and to determine if similar changes can occur in other materials, a series of tests was performed in which Kapton H, Kapton V, FEP Teflon, and PV₂ samples were exposed to illumination for periods of 24 hours. The results of these tests are presented in Section 4.2.

Both metal-electrode and electron-beam tests were performed on each material at temperatures of 22 and 66°C. The metal-electrode tests were performed both with and without an electric-field of 1 kV/mil applied to the samples during the period of illumination. Similarly, electron-beam tests were performed both with and without the test samples exposed to a 15 nA/cm² electron beam with an energy of 1 keV per mil of sample thickness during the period of illumination. All bulk-current measurements were performed in the dark.

The characteristics of 5-mil Kapton V and Kapton H samples were found to be similar under all test conditions. In all metal-electrode tests in which a voltage of 5 kV was applied to Kapton H or Kapton V samples during the period of illumination, the illuminated bulk-current densities increased to greater than 1 $\mu\text{A}/\text{cm}^2$ within a few hours and resulted in electrical breakdowns that caused severe physical damage to the samples and termination of the tests before the end of the 24-hour test period.

In Kapton H and Kapton V metal-electrode tests in which the front-surface electrodes were maintained at ground potential during illumination, the only electrical breakdown to occur was in Kapton V at 66°C. At the end of 24 hours of illumination, the measured dark bulk-current density just prior to sample breakdown was approximately 0.7 $\mu\text{A}/\text{cm}^2$,

which is 8000 times its value prior to illumination. Although sample breakdown did not occur in the Kapton H test at 66°C, the dark bulk-current density after 24 hours of illumination was comparable to that in Kapton V, and it is likely that breakdown conditions would have been reached in a short time with continued illumination.

At 22°C, immediately after 24 hours of illumination with no applied voltage, the dark bulk currents in Kapton V and H were more than three orders of magnitude higher than their preillumination values. Breakdowns were not observed in these tests, and extrapolation of the measured data suggests that at least 24 more hours of illumination would have been required for the bulk-current densities to increase to levels at which breakdowns occurred in other Kapton tests.

In these tests, a 5-kV test voltage was applied immediately after the end of the 24-hour illumination period and dark bulk-current measurements were made 30 s, 5 minutes, and 2 hours after the application of the test voltage. The currents were found to have decreased from the 30-s value by approximate factors of 3 after 5 minutes, and 5 after 2 hours. This current decay may be only partially due to material recovery after prolonged illumination, since dark bulk currents in metal-electrode Kapton samples that have not been illuminated normally decrease by a factor of 2 to 3 within 5 minutes after a test voltage is applied. In any case, the results of illuminated metal electrode tests of both Kapton V and Kapton H, even without a voltage applied during the illumination period, indicate that at 22°C the effective dark bulk resistivities decreased by three orders of magnitude after 24 hours of light exposure, and, after 2 hours in the dark, were still several hundred times higher than their original measured values. At 66°C, the effective dark bulk resistivities of both Kapton V and Kapton H decreased by a factor of approximately 10,000 after 24 hours of illumination, and in Kapton V the resulting high current density caused sample breakdown and damage. In Kapton H, after the 2-hour dark recovery period, the dark bulk current was at least 3000 times its original preillumination value.

24-hour illuminated electron-beam tests of 5-mil Kapton V and Kapton H also resulted in long-term increases in dark bulk-current density, although the maximum possible current densities were limited by the 15-nA/cm^2 , 5-keV electron-beam current density used in these tests. This limitation is reasonable, however, since it is unlikely that the high-energy electron-current densities in a synchronous earth-orbit, even under severe conditions, exceed this magnitude.

In all tests in which Kapton V or Kapton H samples were continuously exposed to a 15-nA/cm^2 , 5-keV electron beam during the entire period of illumination, the measured bulk-current densities immediately before and 30 s after the illuminator was turned off at the end of 24 hours were approximately equal to the electron-beam current density of 15 nA/cm^2 . In all tests in which the electron beam remained off during periods of illumination, the dark bulk-current densities measured 30 s after the electron beam was turned on at the end of the 24-hour illumination period were equal to approximately one-third of the electron-beam current density (i.e., $\approx 5\text{ nA/cm}^2$).

In both types of tests, after 24 hours of illumination and after 2 hours of electron-beam exposure in the dark, the dark bulk currents decreased by a factor of 3 to 4. It should be noted that the dark bulk currents in the Kapton V and Kapton H samples before exposure to illumination were several hundred times lower than the 15-nA/cm^2 electron-beam current density after 30 s of electron-beam exposure, and typically decreased by a factor of 30 after 5 minutes of electron-beam exposure.

The above results indicate that, using both metal-electrode and electron-beam test methods, large and prolonged changes are produced in the dark bulk-resistivity properties of both Kapton V and Kapton H by long periods of illumination. Changes of this type did not result after similar tests of 5-mil FEP Teflon or 2-mil PVF₂.

In both metal-electrode and electron-beam tests of FEP Teflon, the dark bulk currents measured prior to sample illumination were the same as, or slightly lower than, those measured in Kapton prior to illumination, but remained relatively unchanged after the 24-hour illumination

period. In electron-beam tests of 2-mil PVF₂, the dark bulk-current densities prior to illumination, as in the short-term tests, were approximately two orders of magnitude higher than those in Kapton or FEP Teflon. However, immediately after 24 hours of illumination, the dark-bulk current densities in PVF₂ were approximately equal to their preillumination values, and, after 2 hours of 2 keV electron-beam exposure in the dark, had further decreased by two orders of magnitude.

The actual test data from the 24-hour illumination tests are presented in Section 4.2, and some of the implications of these results are discussed in Section 5.

4.2 Results of 24-Hour Illuminated Metal-Electrode and Illuminated Electron-Beam Tests

Test results reported in this section were obtained using both the metal-electrode test setup shown in Figure 1-1 and the electron-beam test setup shown in Figure 1-2. All bulk-current measurements in these tests were made in the dark after the samples had been exposed to 100 mW/cm² of illumination for periods ranging from 0 to 24 hours. For each 24-hour test sequence, newly prepared, previously untested samples were used. In all of the metal-electrode tests, the dark bulk-current measurements were performed with an applied electric field of 1 kV/mil. This corresponds to an applied voltage of 5 kV for the Kapton V, Kapton H, and FEP Teflon samples, which were 5 mils thick, and 2 kV for the PVF₂ samples, which were 2 mils thick.

In some of the metal-electrode tests, the test voltages were applied only immediately after the samples were shielded from illumination at the end of each light exposure period, and were removed immediately before the start of the next light exposure period. In other tests, the test voltages were applied at the start of the 24-hour test sequence and remained on throughout the entire period of light exposure and dark bulk-current measurements.

In all cases, dark bulk-current measurements were made both at 30 s and at 5 minutes after each light exposure period. An additional 2-hour dark measurement was made after a total of 24-hours of light

exposure. The 24-hour electron-beam tests were performed in a manner similar to that used for the metal-electrode tests, except that a 15-nA/cm^2 electron beam with an energy of 1 keV per mil of sample thickness was used in place of the directly applied electric field.

Figure 4-1 illustrates the results of 24-hour illuminated metal-electrode tests on 5-mil Kapton V at 22 and 66°C. As is indicated, no voltage was applied to the test samples during the light exposure period. For each test-sequence, in this and in the other figures in this section a pair of data points representing the 30-s and 5-minute

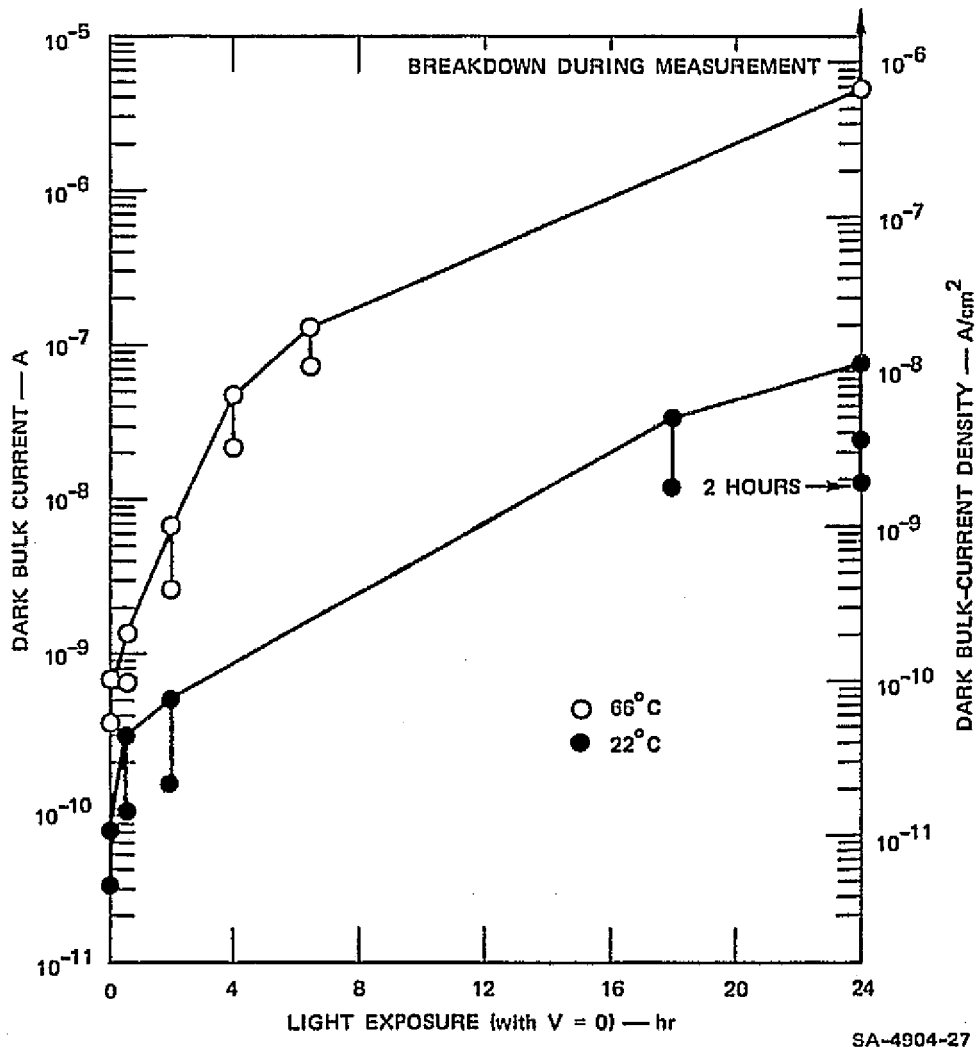

FIGURE 4-1 EFFECTS OF 24 HOURS OF ILLUMINATION WITH NO APPLIED VOLTAGE ON DARK BULK CURRENTS (measured with an applied voltage of 5 kV) IN 5-mil KAPTON V AT 22 AND 66°C

dark bulk currents is shown after each period of light exposure, with an additional 2-hour data point, as noted above, after a total light exposure of 24 hours. All of the 30-s data points in each 24-hour test sequence are connected to each other by sloping lines.

The data shown in Figure 4-1 indicate that even without a voltage applied to the test sample during the period of light exposure, the dark bulk current in Kapton V at 22°C increased by a factor of 1000 after 24 hours of illumination. Approximately 50% of this increase occurred during the last 6 hours of illumination. Two hours after the lamp was turned off, the dark bulk current was still more than 400 times larger than its original measured value. An even greater change (by a factor of ≈ 6500) in dark bulk current was observed in Kapton V at 66°C after 24 hours of illumination with no applied voltage. In this case, during the performance of the dark bulk-current measurements after 24 hours of light exposure, electrical breakdown of the sample occurred, and resulted in a permanent front-surface-to-back-surface short circuit.

24-hour illuminated metal-electrode tests of 5-mil Kapton H produced results very similar to those for Kapton V. Figure 4-2 illustrates the results of Kapton H tests in which no voltage was applied during light exposure periods. A comparison between Figures 4-1 and 4-2 shows that the dark bulk currents in Kapton H after 24 hours of illumination were slightly higher than those measured in Kapton V at 22°C and slightly lower at 66°C.

Kapton V and Kapton H also behaved similarly in 24-hour illuminated metal-electrode tests in which a voltage of 5 kV was applied to the samples during the entire test period, including periods of illumination. The results of these tests are shown in Figures 4-3 and 4-4 for Kapton V and Kapton H, respectively. The dark bulk currents in both Kapton V and Kapton H rose much more rapidly in these tests than in tests in which no voltage was applied during illumination, and in all cases electrical breakdowns resulting in severe sample damage terminated these tests before the end of the 24-hour light exposure period.

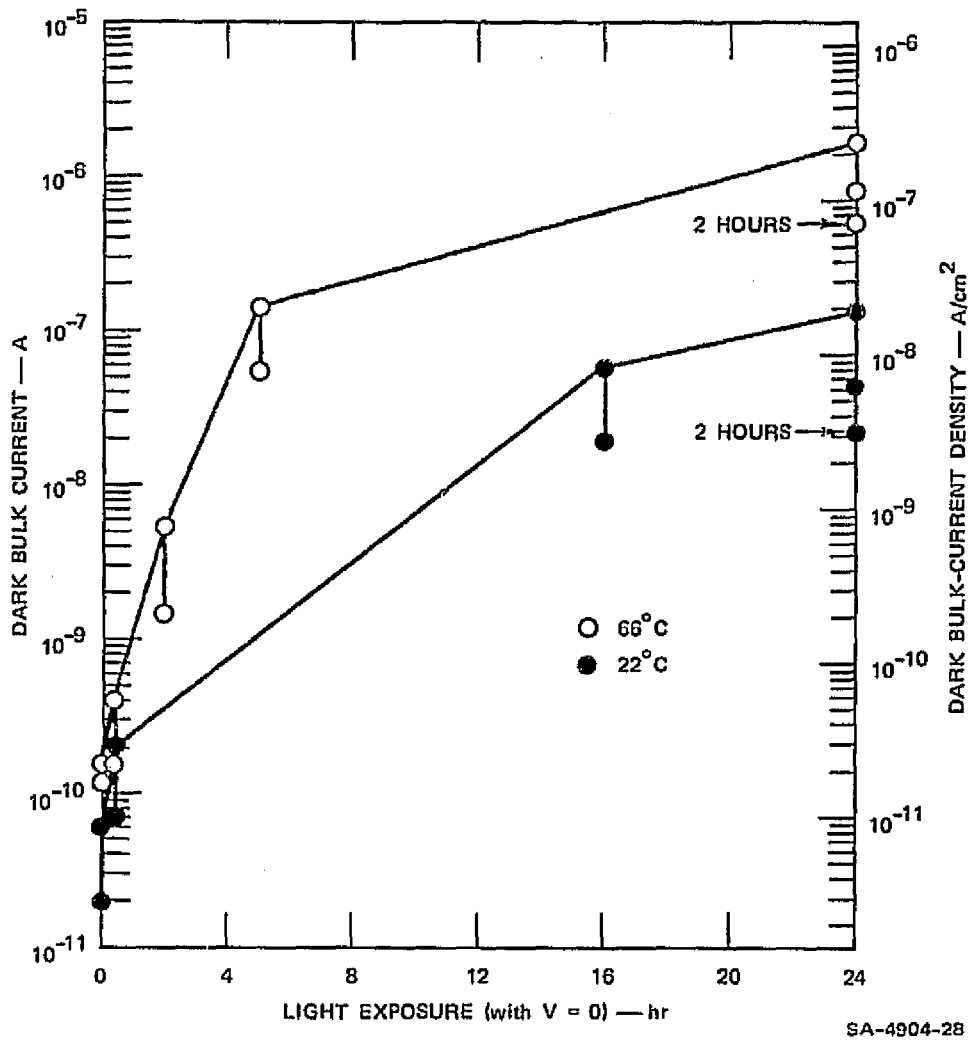

FIGURE 4-2 EFFECTS OF 24 HOURS OF ILLUMINATION WITH NO APPLIED VOLTAGE ON DARK BULK CURRENTS (measured with an applied voltage of 5 kV) IN 5-mil KAPTON H AT 22 AND 66°C

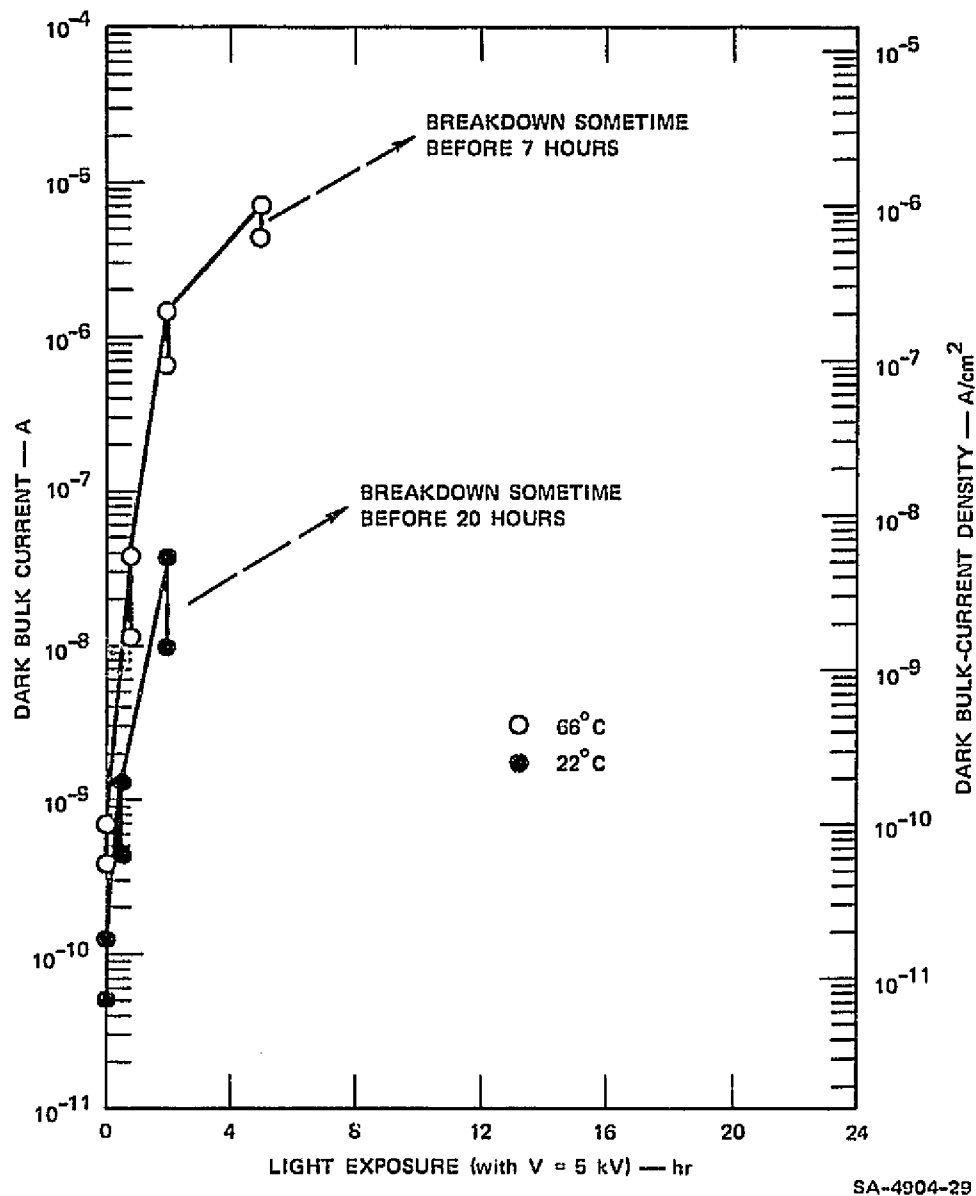

FIGURE 4-3 EFFECTS OF 24 HOURS OF ILLUMINATION WITH AN APPLIED VOLTAGE OF 5 kV ON DARK BULK CURRENTS (measured with an applied voltage of 5 kV) IN 5-mil KAPTON V AT 22 AND 66°C

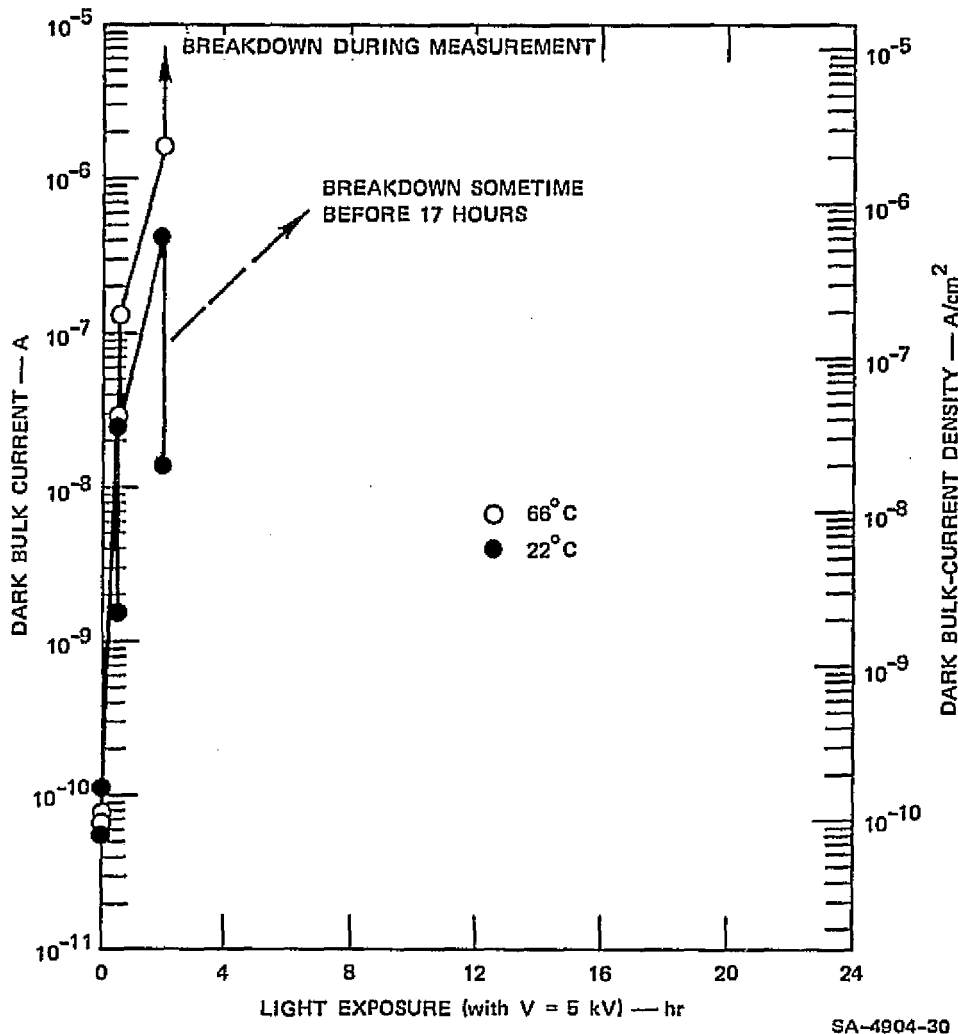

FIGURE 4-4 EFFECTS OF 24 HOURS OF ILLUMINATION WITH AN APPLIED VOLTAGE OF 5 kV ON DARK BULK CURRENTS (measured with an applied voltage of 5 kV) IN 5-mil KAPTON H AT 22 AND 66°C

Experience has indicated that if test conditions are such that bulk-current densities in Kapton V or Kapton H reach and are maintained at a level of approximately $1 \mu\text{A}/\text{cm}^2$, electrical breakdown ultimately results. This current level was reached in all tests performed at 66°C in Figures 4-1 through 4-4, and, although Kapton H in Figure 4-2 did not experience breakdown during the 24-hour test period, it is likely that breakdown was imminent. Also, the illuminated bulk-current densities in the 22°C tests in Figures 4-3 and 4-4 were observed to be in the $1\text{-}\mu\text{A}/\text{cm}^2$ range when the samples were reilluminated immediately following

the last dark bulk-current measurements shown. Less catastrophic results were obtained during 24-hour illuminated electron-beam tests of Kapton V and Kapton H, as is indicated by Figures 4-5 and 4-6. At the end of 24 hours of light exposure, the dark bulk currents in Kapton V and Kapton H were virtually identical and the dark bulk-current densities were approximately equal to the electron-beam current density of 15 nA/cm^2 . In previous short-term tests, bulk-current densities of this magnitude were measured only while the samples were illuminated. In addition, during a 2-hour period following the end of 24 hours of light exposure, the dark bulk-currents in both types of Kapton had decreased by a factor of only 3 and were therefore still at least 3 orders of magnitude higher than their original dark values.

It can be said, however, that at least under certain conditions both Kapton V and Kapton H may recover their initial properties even after long periods of light exposure. This has been shown by repeating 24-hour illuminated electron-beam tests on samples of Kapton V and H

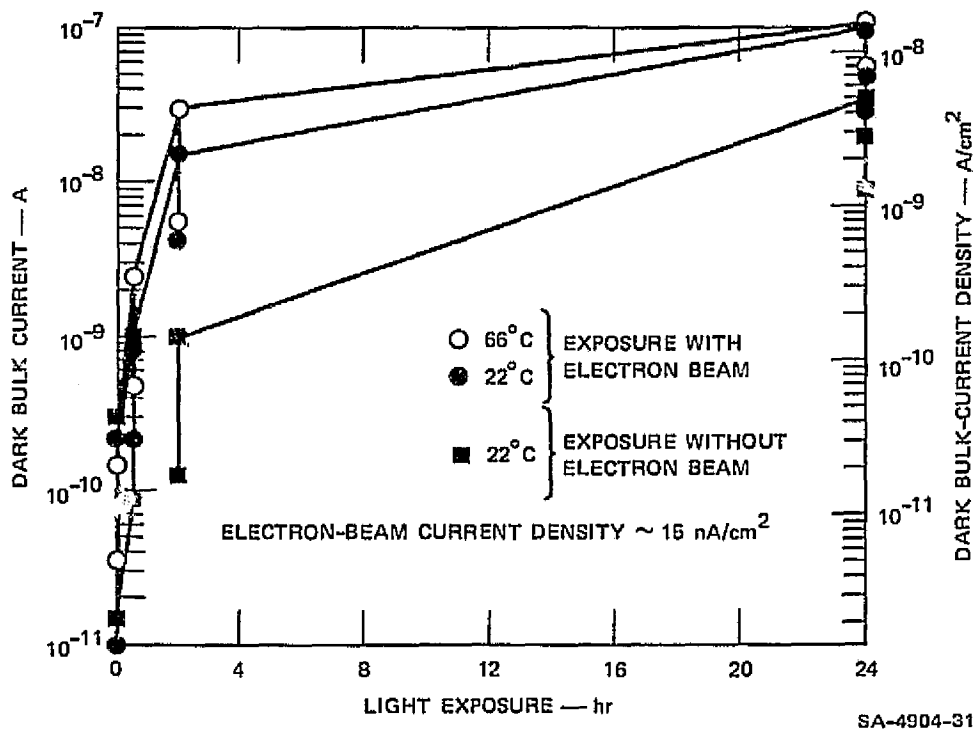

FIGURE 4-5 EFFECTS OF 24 HOURS OF ILLUMINATION WITH AND WITHOUT A 5-keV ELECTRON BEAM ON DARK BULK CURRENTS IN 5-mil KAPTON V

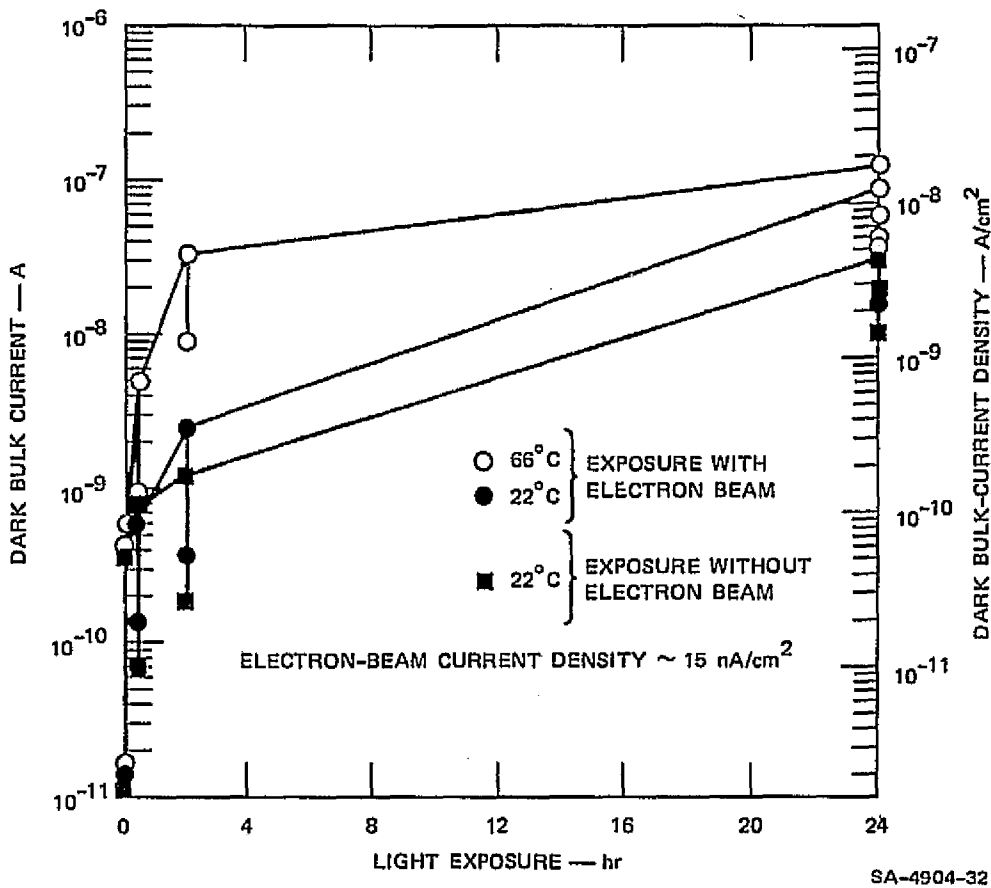

FIGURE 4-6 EFFECTS OF 24 HOURS OF ILLUMINATION WITH AND WITHOUT A 5-keV ELECTRON BEAM ON DARK BULK CURRENTS IN 5-mil KAPTON V

that had been previously tested and that had been stored in the laboratory environment at a pressure of one atmosphere for a period of almost two months prior to retesting. The samples used in these tests were those previously tested at 22°C with the electron beam on during the light exposure period. For both samples, the data obtained before and during the second 24-hour tests matched the data from the original 24-hour tests shown in Figures 4-5 and 4-6 to within 10%.

Illuminated 24-hour tests on FEP Teflon and PVF₂ produced results quite different from those on Kapton, in that no significant changes in the dark bulk-currents in these materials were observed. The 24-hour illuminated metal-electrode test data for FEP Teflon are shown in Figure 4-7. In these tests, the dark bulk currents in FEP Teflon

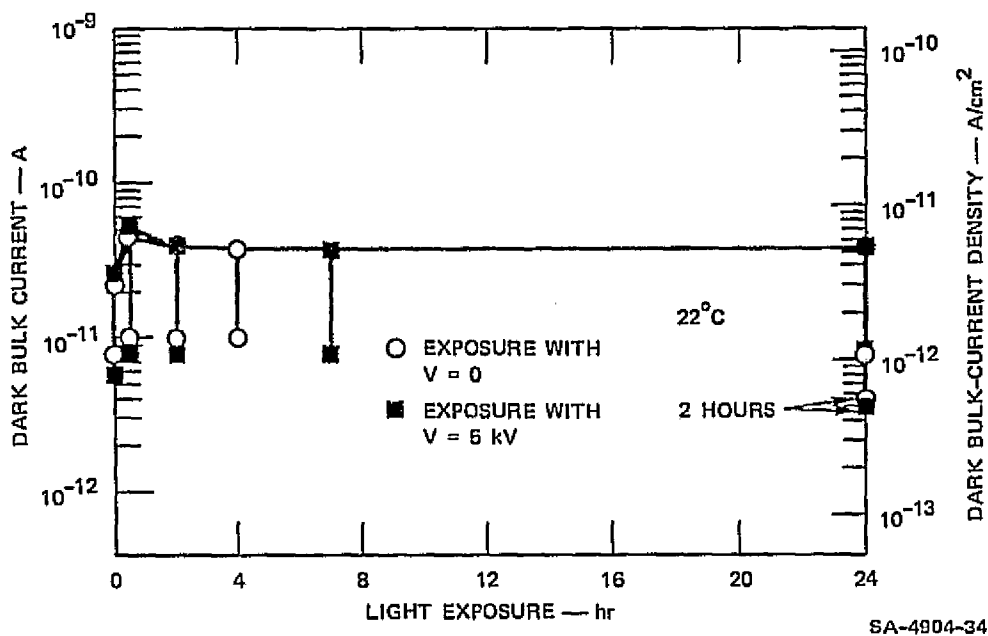

FIGURE 4-7 EFFECTS OF 24 HOURS OF ILLUMINATION WITH AND WITHOUT AN APPLIED VOLTAGE OF 5 kV ON DARK BULK CURRENTS (measured with an applied voltage of 5 kV) IN 5-mil FEP TEFLON

remained virtually unchanged throughout the 24-hour period regardless of whether the sample was subjected to an applied electric field during the illumination period.

The results of 24-hour illuminated electron-beam tests on FEP Teflon are shown in Figure 4-8. During the tests in which the electron beam was turned off during the light exposure period, the dark bulk current in FEP Teflon decreased by a factor of 10 after the first 30 minutes of light exposure, but had returned to its original value by the end of the 24-hour period. In the tests in which the electron beam remained on during the entire 24-hour period, the dark bulk current increased by a factor of 4 after the first 30 minutes of exposure and remained at that level throughout the test.

The dark bulk-currents in FEP Teflon in both the metal-electrode and electron-beam tests were of comparable magnitude and, in the electron-beam tests, the dark bulk-current density was approximately 0.1% of the electron-beam current density immediately after the samples were shielded from illumination.

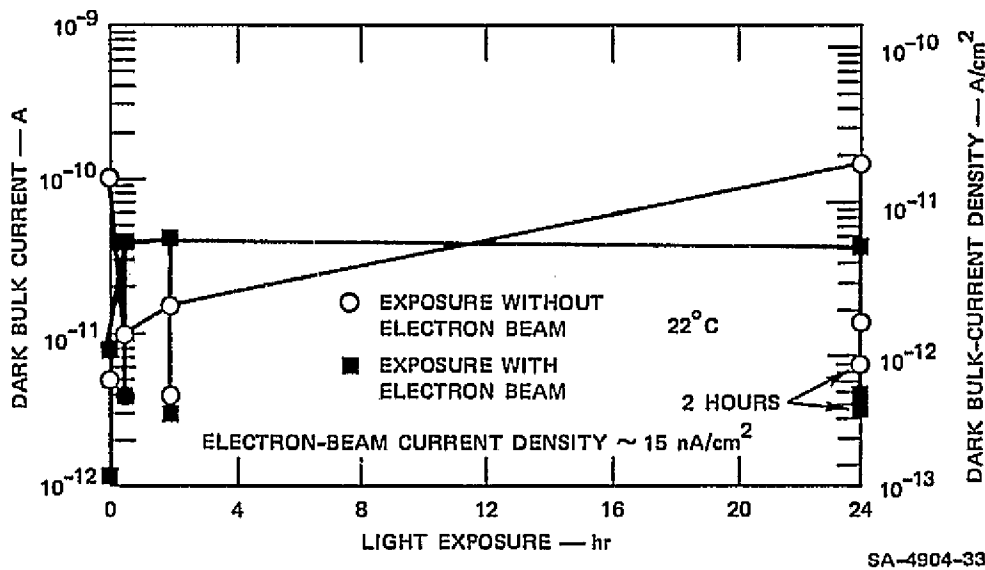

FIGURE 4-8 EFFECTS OF 24 HOURS OF ILLUMINATION WITH AND WITHOUT A 5-keV ELECTRON BEAM ON DARK BULK CURRENTS IN 5-mil FEP TEFLON

Due to heating and physical damage to metal-electrode PVF_2 samples by illumination (as described in Section 2.3), 24-hour illumination tests on PVF_2 were performed using the electron beam only. The results of these tests are shown in Figure 4-9. As was observed in FEP Teflon, there are some variations in the dark bulk currents in PVF_2 during the early portions of these tests. The dark bulk currents in tests in which the sample was exposed to illumination in the absence of the electron beam remained relatively constant throughout the 24-hour test period. In the tests in which the sample was exposed to the electron beam during the light-exposure period, the dark bulk currents decreased after the first two hours of light exposure and remained relatively constant thereafter.

The data in Figure 4-9 also indicate that, although the initial dark bulk current in PVF_2 may be considerably higher than that in FEP Teflon and in Kapton, it does not appear to increase with long periods of light exposure, and after 2 hours of electron-beam exposure in the dark the bulk current may decrease by as many as 3 orders of magnitude.

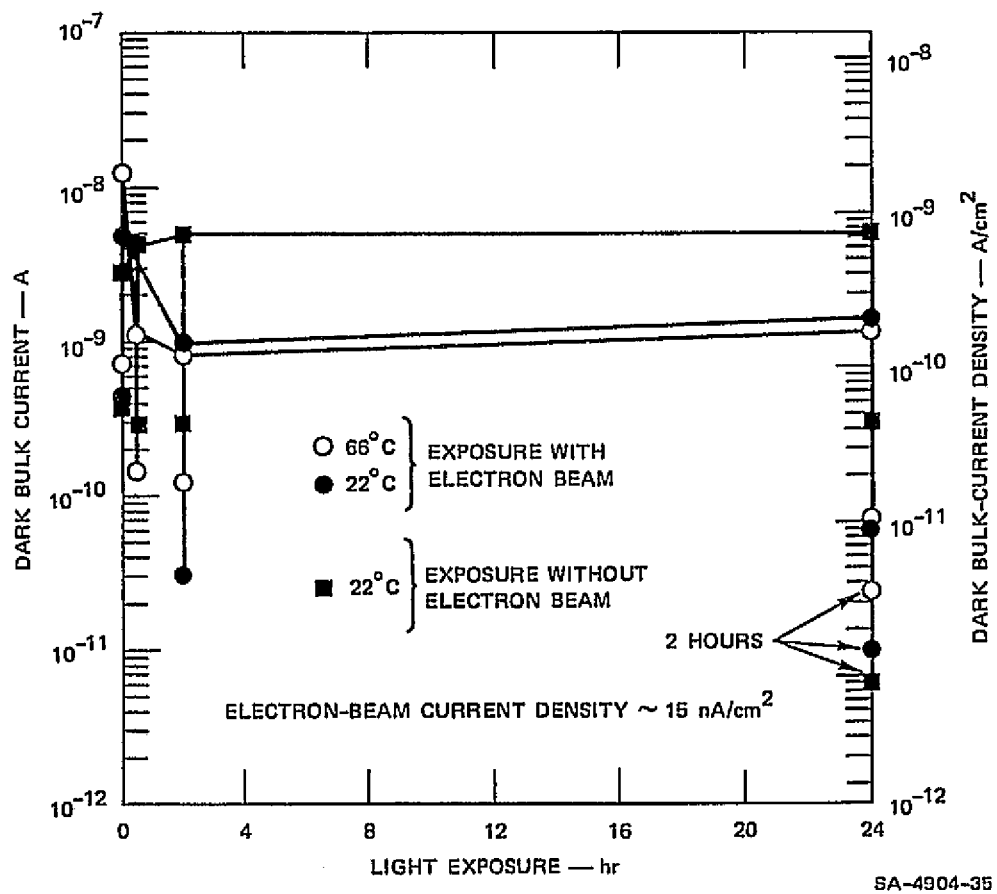

FIGURE 4-9 EFFECTS OF 24 HOURS OF ILLUMINATION WITH AND WITHOUT A 5-keV ELECTRON BEAM ON DARK BULK CURRENTS IN 2-mil PVF₂

5. OVERALL SUMMARY AND CONCLUSIONS

5.1 Summary

The results of tests performed on this program indicate that the electrical conductivity properties of some thin-film insulating materials are significantly altered by exposure to illumination.

Of the materials tested, Kapton, a widely used spacecraft material, was found to exhibit the greatest changes in conductivity. The bulk conductivity of Kapton increased by as much as four orders of magnitude during brief periods of illumination. In addition, the dark bulk conductivity of Kapton immediately after 24 hours of illumination was from three to four orders of magnitude higher than its preillumination value, and decreased by a factor of 5 or less during a 2-hour recovery period in the dark. In tests in which a 5-kV voltage was applied to Kapton samples during illumination, the resulting high bulk currents produced electrical breakdown and severe physical damage to the samples before the end of the 24-hour test period. It was also found that the dark bulk conductivity of Kapton increased by up to two orders of magnitude when the sample temperature was increased from 22°C to 100°C.

The dark bulk conductivities of FEP Teflon and Kapton samples were of comparable magnitude prior to illumination, but, unlike Kapton, FEP Teflon retained its insulating properties without significant change after 24 hours of illumination and at increased temperatures.

The dark bulk conductivity of polyvinylidene fluoride (PVF₂) was found to be up to two orders of magnitude higher than that of Kapton or FEP Teflon prior to illumination, but did not appear to increase significantly with temperature and actually decreased somewhat after 24 hours of illumination.

5.2 Conclusions and Recommendations

The bulk-conductivity properties of thin-film insulating materials exposed to the space environment may differ by many orders of magnitude from material to material as well as from published specifications. Based on the results of this program, it appears that, of the materials tested, FEP Teflon is the most useful in applications in which high leakage resistance is required of a material that will be exposed to solar illumination.

In choosing a material for use in a particular spacecraft application, the importance of electrical properties must be considered in relation to many other factors including thermal, optical, and mechanical properties and total material cost and weight. Based on leakage-current considerations, FEP Teflon would appear to be the best choice for use as a high-voltage solar array substrate. Kapton H or Kapton V would be acceptable alternatives for this application only if the upper layers of the array structure provide almost complete shielding from solar illumination. Furthermore, in this case, the leakage resistance of Kapton would be as high as that of FEP Teflon only if the substrate temperature was maintained at or less than 22°C. It should be noted that the above statements are based on tests of 5-mil-thick material samples, and that thinner samples of many materials, including Kapton and FEP Teflon, may contain microscopic pinholes that substantially increase bulk leakage currents. PVF₂ has the advantage of being available in thinner (e.g., 0.25-mil) pinhole-free sheets than most other plastic-like thin-film insulating materials, although, during laboratory tests, this material tended to soften and distort physically at higher temperatures.

If somewhat higher leakage currents could be tolerated, PVF₂ could be considered for use as a low-voltage solar array substrate, but its advantage of being available in thin pinhole-free films is overcome for high-voltage array applications by the fact that, even in the dark, 2-, 1-, and 0.25-mil PVF₂ samples suffered electrical breakdown with applied voltages of the order of 5, 2, and 1 kV, respectively.

FEP Teflon would also appear to be the best choice, among the materials tested, for use as a solar-cell cover in a high-voltage array due to its higher leakage resistance and dielectric strength under illumination, as well as its relatively high optical transmission properties throughout the visible portion of the spectrum. Kapton would be a poor choice in this application due to its poor optical transmission properties in the visible spectrum and to its low leakage resistance under direct illumination. PVF₂ has a relatively low optical density throughout the visible range, but again, due to the lower leakage resistance and dielectric strength of PVF₂ thin films, FEP Teflon appears to be the better choice for high-voltage-array applications.

As was mentioned in the introduction to this report, thin-film dielectric materials are also widely used as the outer layers of passive thermal-control surfaces on modern spacecraft. For this application, consideration has traditionally been given to the thermo-optical and physical characteristics of these materials rather than to their electrical properties. Recently, however, the results of theoretical analyses, laboratory tests, and in-flight experiments have indicated that many spacecraft anomalies are attributable to the electrical charging of portions of spacecraft surfaces to high potentials under certain environmental conditions.

In general, the potentials of various portions of the spacecraft are determined by the characteristics of the local charged-particle population and the presence or lack of solar illumination in the environment, by the secondary emission, backscatter, and photoemission properties of the materials involved, and by the electrical properties of the various conduction paths between materials directly or through the environment. The potentials of various portions of a single insulator, of separate insulators, of isolated conductors, and of the spacecraft frame may all differ with respect to each other and with respect to the local plasma potential. These differences in potential can cause attraction and deposition of contaminants, interfere with the operation of electric-field-sensitive or charge-sensitive instruments, and produce electrical

breakdowns that can result in physical damage to materials and electrical interference in, or physical damage to, electrical or electronic systems.

Due to the nature of a high-voltage solar array, special consideration must be given to spacecraft charging phenomena in designing a high-voltage solar array vehicle. For example, even on a vehicle using a low-voltage array, large differences in potential due to spacecraft charging effects may exist between portions of array insulators and the vehicle frame and therefore between portions of the array and the array ground bus, which is ultimately tied directly or indirectly to the vehicle frame. The magnitudes and polarities of these differences in potential will, of course, depend on environmental conditions, as well as on the vehicle's materials and construction.

On a vehicle using a high-voltage solar array, the solar cells and the power bus at the high-voltage end of the array may be electrically maintained at a potential of many kilovolts with respect to the array ground bus. This potential, depending on its polarity, will either add to or subtract from any potential differences that may exist due to spacecraft charging effects.

Potentials of several kilovolts in sunlight and of greater than 10 kV during vehicle eclipse have been observed at synchronous orbit. These values may not be the highest attained, since they are based on a limited number of observations and since very few satellites are presently instrumented to monitor spacecraft charging events. However, even potentials of the observed magnitudes could considerably increase the electrical requirements of high-voltage array materials. Spacecraft charging effects must therefore be taken into account and either reduced or compensated for by proper materials selection and physical and electrical design for both the high-voltage array or arrays and the vehicle itself. Perhaps the enhanced conductivity of Kapton during and after illumination could be used to reduce spacecraft charging effects in some applications.

The interactions between insulating materials and their environment can be quite complex, even in a relatively simple test setup, as is evidenced for example, by the electron-beam test results described in this report. Both in laboratory tests and on vehicles in space, the instantaneous currents and potential distributions in exposed insulating materials are strongly affected by previous environmental conditions. Solar illumination of satellite surfaces may vary regularly, due to vehicle rotation and to changes in orientation and orbital position, and the local charged-particle environment may vary irregularly due to magnetospheric processes. Because of these variations, steady-state analyses or measurements may not provide completely valid design information. Overly simplified tests or analyses may mask the complexities of actual material behavior in the space environment. Some care should therefore be exercised in choosing material test methods or analyses and in interpreting their results to ensure that they adequately represent the expected operating conditions.

The test conditions and test sequences described in this report were necessarily limited, but the results obtained should provide valuable baseline information on material properties and the effects of some aspects of the space environment. This information should be useful to those involved in spacecraft materials selection, the development of new materials, and the modeling or testing of interactions of spacecraft materials with their environment.

The results of this program should also serve to indicate areas in which additional theoretical and experimental efforts are required.

REFERENCES

- Burkard, H. and G. Pfister, "Reversible Pyroelectricity and Inverse Piezoelectricity in Polyvinylidene Fluoride," J. Appl. Phys., Vol. 45, No. 8, pp. 3360-3364 (August 1974).
- Coffey, H. T., J. E. Nanevich, and R. C. Adamo, "Photoconductivity of High-Voltage Space Insulating Materials," Final Report, Contract NAS3-18912, SRI Project 3545, Stanford Research Institute, Menlo Park, California (October 1975).
- Nanevich, J. E. and R. C. Adamo, "A Rugged Electron/Ion Source for Spacecraft Charging Experiments," paper presented at the Spacecraft Charging Technology Conference co-sponsored by the United States Air Force and National Aeronautics and Space Administration, Colorado Springs, Colorado, 27-29 October 1976.
- "Standard Methods of Test for D-C Resistance or Conductance of Insulating Materials," ASTM Designation D257-66, American Society for Testing and Materials (1966).
- van Turnhout, J., Thermally Stimulated Discharge of Polymer Electrets (Elsevier Scientific Publishing Company, Amsterdam, The Netherlands, 1975).

~~PRECEDING PAGE BLANK NOT FILMED.~~