

FINAL REPORT

For

Contract NAS8-31668

(NASA-CR-150045) UNDERGROUND COAL MINE
INSTRUMENTATION AND TEST Final Report
(Shaker Research Corp., Ballston Lake, N.
Y.) 129 p HC A07/MF A01

N77-33479

CSCL 14B

Unclas

G3/35

47893

UNDERGROUND COAL MINE INSTRUMENTATION AND TEST

Prepared By

R. F. Burchill

W. D. Waldron

Prepared For

George C. Marshall Space Flight Center
Marshall Space Flight Center
Alabama 35812

Under The Direction Of

John L. Burch
Contracting Officer's Representative
EC 25/205-453-3447

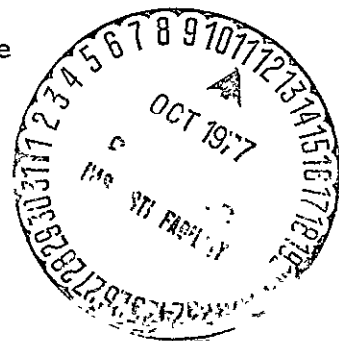

SHAKER RESEARCH CORPORATION
Northway 10 Executive Park
Ballston Lake, N. Y. 12019

FINAL REPORT

For

Contract NAS8-31668

UNDERGROUND COAL MINE INSTRUMENTATION AND TEST

Prepared By

R. F. Burchill
W. D. Waldron

Prepared For

George C. Marshall Space Flight Center
Marshall Space Flight Center
Alabama 35812

Under The Direction Of

John L. Burch
Contracting Officer's Representative
EC 25/205-453-3447

SHAKER RESEARCH CORPORATION
Northway 10 Executive Park
Ballston Lake, N. Y. 12019

ACKNOWLEDGMENTS

Shaker Research Corporation would like to acknowledge the assistance provided us in the many phases of this program and to express gratitude to the number of people who contributed time, information, and access to some very expensive coal mining equipment and facilities. A partial list includes:

Mr. John Burch	Program Technical Monitor	NASA, MSFC Huntsville, Ala.
Dr. Richard A. Campbell	Task Leader - CID Program	NASA, MSFC Huntsville, Ala.
Mr. R. Pease	Program Manager	NASA, MSFC Huntsville, Ala.
Mr. Eugene R. Palowitch	Deputy Research Director	Pittsburgh Mining & Safety Research Center U.S. Bureau of Mines, Pittsburgh, Pa.
Mr. Carl Erickson	Longwall Project Engineer	Joy Manufacturing Co. Franklin, Pa.
Mr. J. C. Barker	Sales/Service Representative	Joy Manufacturing Co. Richlands, Va.
Mr. Gene Jones	VP Operations	Rochester & Pittsburgh Indiana, Pa.
Mr. Mike Hudak	Manager of Mines	Consolidation Coal Company Manonga, W. Va.
Mr. High Blackburn	Superintendent Kopperston #2 Mine	Eastern Associated Coal Company Kopperston, W. Va.
Mr. John Price	Face Foreman, Longwall Training Face, Kopperston #2 Mine	Eastern Associated Coal Company Kopperston, W. Va.
Mr. Bill Walker	Director of Research	Carmet Mine Tools Shinnston, W. Va.
Mr. Ken Winters	President	Appalachian Fuel Co. Huntington, W. Va.
Mr. Kenneth T. Phillips	Vice President	Chas. Phillips Tool Co., Mannington, W. Va.

TABLE OF CONTENTS

	<u>Page</u>
1.0 INTRODUCTION _____	1
2.0 EQUIPMENT DESIGN AND SELECTION _____	2
2.1 Basic Data System _____	2
2.2 MESA Intrinsic Safety Requirements _____	3
2.3 Data Recorder _____	6
2.4 Data Amplifier System EN 211 _____	14
2.5 Strain Amplifier System EN 217 _____	16
2.6 Sound Measurement System _____	19
2.7 Transducer Selection _____	21
2.7.1 Low Frequency Acceleration _____	21
2.7.2 High Frequency Acceleration _____	22
2.7.3 Pressure Transducers _____	23
2.7.4 Strain Gages _____	25
2.7.5 Temperature Measurement _____	25
2.8 Mine Data Review Instrumentation _____	25
2.9 Out-of-Mine Data Review _____	27
3.0 DRUM DATA TRANSMISSION REVIEW _____	28
4.0 MINE TEST SITE REVIEW _____	29
5.0 MINE DEMONSTRATION TEST _____	30
5.1 Mine Test Location _____	30
5.2 Mine Description _____	30
5.3 Test Equipment Installation _____	31
5.4 Test Data Review _____	31
6.0 SUMMARY _____	65

LIST OF FIGURES

	<u>Page</u>
2.3.1 Mine Tape Recorder and Accessories _____	7
2.3.2 Shock Mounted Recorder _____	7
2.3.3 Tape Recorder Battery Mount _____	9
2.3.4 Current Limiter Performance _____	10
2.3.5 Modified Tape Recorder Circuit _____	12
2.3.6 Tape Recorder Current Limited Startup _____	13
2.4.1 EN211 Data Amplifier Assembly _____	15
2.5.1 Strain Amplifier Assembly EN217 _____	17
2.5.2 Wheatstone Bridge Strain Gage Circuit _____	18
2.5.3 Strain Gage Circuit Using Only One Gage _____	18
2.6.1 Sound Measurement System _____	20
2.7.1 Pressure Transducer Calibration _____	24
5.3.1 Mine Test Equipment Travel Configuration _____	32
5.3.2 Mine Equipment Installation in Kopperston #2 _____	33
5.3.3 Mine Equipment Installation Bench Simulation _____	33
5.3.4 Sensor Locations - Joy Shearer _____	34
5.4.1 Tape Channel 2 B&K Accelerometer Left Hand Drum Axial _____	40
5.4.2 Tape Channel 3 PCB Accelerometer Drive Hub 45 ^o Gob Side _____	41
5.4.3 Tape Channel 4 B&K Accelerometer Right Hand Drum Axial _____	42

List of Figures (con't)	<u>Page</u>
5.4.4 Tape Channel 5 PCB Accelerometer Right Hand Foot Vertical Gob Side _____	43
5.4.5 Tape Channel 7 PCB Accelerometer Face Side Frame Vertical_	44
5.4.6 Tape Channel 3 PCB Accelerometer/Double Integrated Drive Hub 45° - Gob Side _____	45
5.4.7 Tape Channel 5 PCB Accelerometer/Double Integrated Right Hand Foot Vertical - Gob Side _____	46
5.4.8 Tape Channel 7 PCB Accelerometer/Double Integrated Right Hand Foot Vertical - Gob Side _____	47
5.4.9 Tape Channel 1 Accelerometer Output Spectrum Analysis Normal Cut Moving Left _____	48
5.4.10 Tape Channel 1 Accelerometer Output Spectrum Analysis Normal Cut Moving Left _____	49
5.4.11 Tape Channel 2 Accelerometer Output Spectrum Analysis Normal Cut Moving Left _____	50
5.4.12 Tape Channel 3 Accelerometer Output Spectrum Analysis Normal Cut Moving Left _____	51
5.4.13 Tape Channel 3 Accelerometer Output Spectrum Analysis Normal Cut Moving Left _____	52
5.4.14 Tape Channel 4 Accelerometer Output Spectrum Analysis Normal Cut Moving Left _____	53
5.4.15 Tape Channel 4 Accelerometer Output Spectrum Analysis Normal Cut Moving Left _____	54
5.4.16 Tape Channel 5 Accelerometer Output Spectrum Analysis Normal Cut Moving Left _____	55
5.4.17 Tape Channel 5 Accelerometer Output Spectrum Analysis Normal Cut Moving Left _____	56
5.4.18 Tape Channel 6 Microphone Output Spectrum Analysis Normal Cut Moving Left _____	57
5.4.19 Tape Channel 7 Accelerometer Output Spectrum Analysis Normal Cut Moving Left _____	58

List of Figures (con't)	<u>Page</u>
5.4.20 Tape Channel 7 Accelerometer Output Spectrum Analysis Normal Cut Moving Left-----	59
5.4.21 Tape Channel 3 Accelerometer/Double Integrated Output Spectrum Analysis Normal Cut Moving Left-----	60
5.4.22 Tape Channel 5 Accelerometer/Double Integrated Output Spectrum Analysis Normal Cut Moving Left-----	61
5.4.23 Tape Channel 7 Accelerometer/Double Integrated Output Spectrum Analysis Normal Cut Moving Left-----	62

1.0 INTRODUCTION

Increasing production demands upon the coal mining industry have initiated efforts in several areas to provide transducers and control equipment which can be used to improve production and safety features of coal mining equipment. The need to evaluate mechanical performance of mine tools and to obtain test performance data from candidate systems dictate that an engineering data recording system be built. Because of the wide range of test parameters which would be evaluated, a general purpose data gathering system was designed and assembled to permit maximum versatility. Experience in field testing of process machinery in hazardous or inaccessible locations was used in selecting transducers, signal conditioning equipment, monitoring equipment, and recording equipment for use in the difficult test surroundings of an operating coal mine. Emphasis was placed upon versatility of performance, rugged construction, portability, ease of usage, and accuracy.

A primary objective of this program was to provide a specific operating evaluation of a longwall mining machine vibration response under normal operating conditions. A number of mines were visited and a candidate for test evaluation was selected, based upon management cooperation, machine suitability, and mine conditions. It happened that the candidate mine was in the state of Pennsylvania so the additional requirement of review by the Pennsylvania Office of Deep Mine Safety was required for the mine test instrumentation system.

Actual mine testing took place in the Kopperston #2 mine of Eastern Associated Coal Company at Kopperston, West Virginia with the cooperation of Eastern and Joy Manufacturing Company.

2.0 EQUIPMENT DESIGN AND SELECTION

2.1 Basic Data System

The measurement of machinery dynamic performance under the wide variety of operating conditions and the unlimited transducer output range possible dictates the maximum of flexibility in the selection of a system to record data. Selection of suitable recording equipment was based upon the following requirements:

1. Minimum physical size and weight
2. Maximum parallel data capability
3. Intrinsic safety requirements
4. Maximum data record length
5. Broad frequency response
6. Severe operating environment
 - a. Unknown but significant mechanical shock
 - b. Water spray potential
 - c. Dust
7. Remote control of functions
8. Accuracy and repeatability

No implied priority is attached to this listing as all the items impact upon the usefulness of the system.

In considering the basic data parameters which might be evaluated, several specific recorder requirements were identified which immediately limited the available candidates. It was decided that more than four data channels were necessary to permit correlation of several data parameters. Voice annotation is required to allow a running commentary of operating conditions as often the normal control responses by the machine operator are based upon visual or audible inputs which need to be related to performance changes.

As a minimum, one hour of recording operation is necessary to permit a reasonable range of mining conditions to be evaluated. It is anticipated that in some cases the test equipment will be mounted on the operating machine and may not be available for continuous start and stop control by the test personnel. The electronics will be turned on and then the mining machine will proceed into a work cycle which may last several hours. When the test instrumentation system is again available it can be turned off.

Because of close quarters and sometimes difficult terrain the handling of equipment is a significant physical effort, so individual components of the instrumentation package were targeted for weights no more than 45 pounds. This requirement, along with the need (desire) to contain the equipment and battery power supplies within the same case, further restricted the selection of a recording system. The most severe restriction, however, came from intrinsic safety requirements imposed by Mining Enforcement and Safety Administration on all mine applied equipment. The equipment assembled for this project was reviewed and tested by MESA and a permit issued to cover use of the specific battery powered components in the package in gassey coal mines.

2.2 MESA Intrinsic Safety Requirements

The primary document describing the requirements of mine safe electrical equipment for mine use is contained in Bureau of Mines Schedule 2G, "Electric Motor-driven Mine Equipment and Accessories". Quoting from that document, "Intrinsically Safe" means incapable of releasing enough electrical or thermal energy under normal or abnormal conditions to cause ignition of a flammable mixture of methane or natural gas and air of the most easily ignitable composition". Under Section 18.68, tests for intrinsic safety, a test cycle is described where a minimum of 1000 make-break sparks are produced within a chamber containing the gas-air mixture, with full battery circuit output current being discharged across the sparking contacts. Further, each half of the required redundant current-limiting circuitry must pass this test, insuring that a component failure does not leave the system

unprotected. The test arrangement applied to evaluate a battery system consists of a cadmium wheel turning at moderate speed inside a gas-filled test chamber, with a multiple wire "brush" dragging on the O.D. of the cadmium wheel. The contacts of the battery output are wired across the brush contact, and the wheel is turned at least 1000 revolutions without gas ignition for a passing test. In addition to the gas ignition test, any proposed electronic equipment is reviewed to insure that no component is operating at greater than 50% of rated load, and that no significant energy storage capability exists which could produce an incendiary spark: inductors and capacitors are carefully reviewed. Mechanical and structural integrity are considered to insure that components will remain in place during normal mine handling.

The stringent test requirements place heavy demands upon system designers as qualification depends upon an objective test: passing only requires that no mixture ignition take place in a very specific test example. The voltage, current, and wattage limit values for an individual system are not part of the specification so any system approaching recognized limits must be tested. Some guidelines do exist which permit initial consideration of intrinsic safety power capabilities for a battery-powered instrument. It has been found that resistance element current limited battery circuits can pass the cadmium wheel brush test with current levels of ten amps at 12 volts, three amps at 18 volts, and one amp at 24 volts.

Resistance current limiting is simple, inexpensive, and predictable, but costly in terms of power dissipation and voltage drop. A permitted assembly can be made up of batteries, two series wire-wound resistors with current ratings at twice that possible from a short-circuited output, potting for encapsulation of electrical components, and a substantial case for mechanical strength and protection from damage. For moderate power consumption devices the resistor values can be fairly high so power dissipation is reasonable, but any arrangement operating near the allowable limits of current will consume a significant portion of its battery life in resistance heating.

An alternate to resistance limiting is to use a solid state current limiting device which minimizes power consumption. The limiting characteristics of such a system can be adjusted by component selection to cut off sharply under short-circuit conditions yet permit operation nearer the rule-of-thumb limits which will pass the cadmium wheel brush test.

The type of battery used has a significant influence on the difficulty of providing intrinsic safety capability. In general, the high density storage units such as alkaline manganese, mercury, lithium, and lead gell types have rather high short-circuit current supply capabilities which must be externally limited, but the common zinc carbon types tend to be self limiting by increased internal resistance under high drain operating conditions. Therefore, some milliamp drain equipment can be operated at relatively high voltage values without the complication of current limiting circuitry:

There is a final option for the use of potentially incentive electrical equipment in a gassey mine, that of mounting the complete system within an approved explosion-proof enclosure. Equipment which is permanently mounted on mine machines can be so mounted with significant penalties in weight and bulk. The use of such enclosures for a portable system is nearly out of the question.

It should be noted that many manufacturers produce electronic equipment for mine use which are covered under a somewhat different MESA intrinsic safety requirement. These devices are required to meet the rigid safety requirements but an approval number is given which allows the manufacturer to produce unlimited exact duplicates of the tested device, and to equip each with a certification label attesting to the MESA approved use of it in gassey mines and tunnels. The "permit" issued by MESA allows only the specific hardware evaluated by MESA personnel to be used in gassey mines and tunnels: even an exact duplicate would have to be reviewed and a new permit issued.

2.3 Data Recorder

The data recording system selected for mine testing is based upon I.R.I.G. standard intermediate band using 1/2 inch wide magnetic tape which provides seven data channels plus an edge voice track. Both FM and Direct recording capability can be selected so that transducer output signals in the one volt r.m.s. range from DC to 100,000 Hz can be recorded. The use of magnetic tape permits test information to be reviewed and manipulated in a variety of ways, and in effect allow the test cycle to be repeated many times away from the severe environment of the mine.

The particular recorder selected was a Lockheed Electronics Model 417D with modifications for intrinsic safety and with a special current-limited battery pack mounted within its environmental case. The unit has selectable tape speeds of 7-1/2 ips, 15 ips, and 30 ips, and the plug-in electronics were purchased for 15 ips operation. This provides a reasonable compromise between frequency response and data record length. FM channels give linear response from DC to 5,000 Hz (± 0.5 dB) and Direct channels produce linear response from 100 Hz to 50,000 Hz (± 3 dB), and one 2300 foot reel of tape provides 30 minutes of continuous recording time. Up to five reels of data can be recorded before recharge of the battery pack is necessary.

The recorder and its accessories are shown on Figure 2.3.1. Included are the recorder itself, a Shure noise cancelling microphone for voice annotation, a battery charger/power supply for laboratory operation and out-of-mine recharging, and a remote control operator for Start/Stop and Record functions. Figure 2.3.2 shows the recorder in the mine operation made with environmental cover in place and mounted on its shock absorbing vibration mounting.

A number of competitive recorders were reviewed before selection of this particular machine, but none provided the versatility, low power consumption, and rugged construction features of the Lockheed 417D. Cassette recorders are physically smaller and lower in power consumption, but are very limited

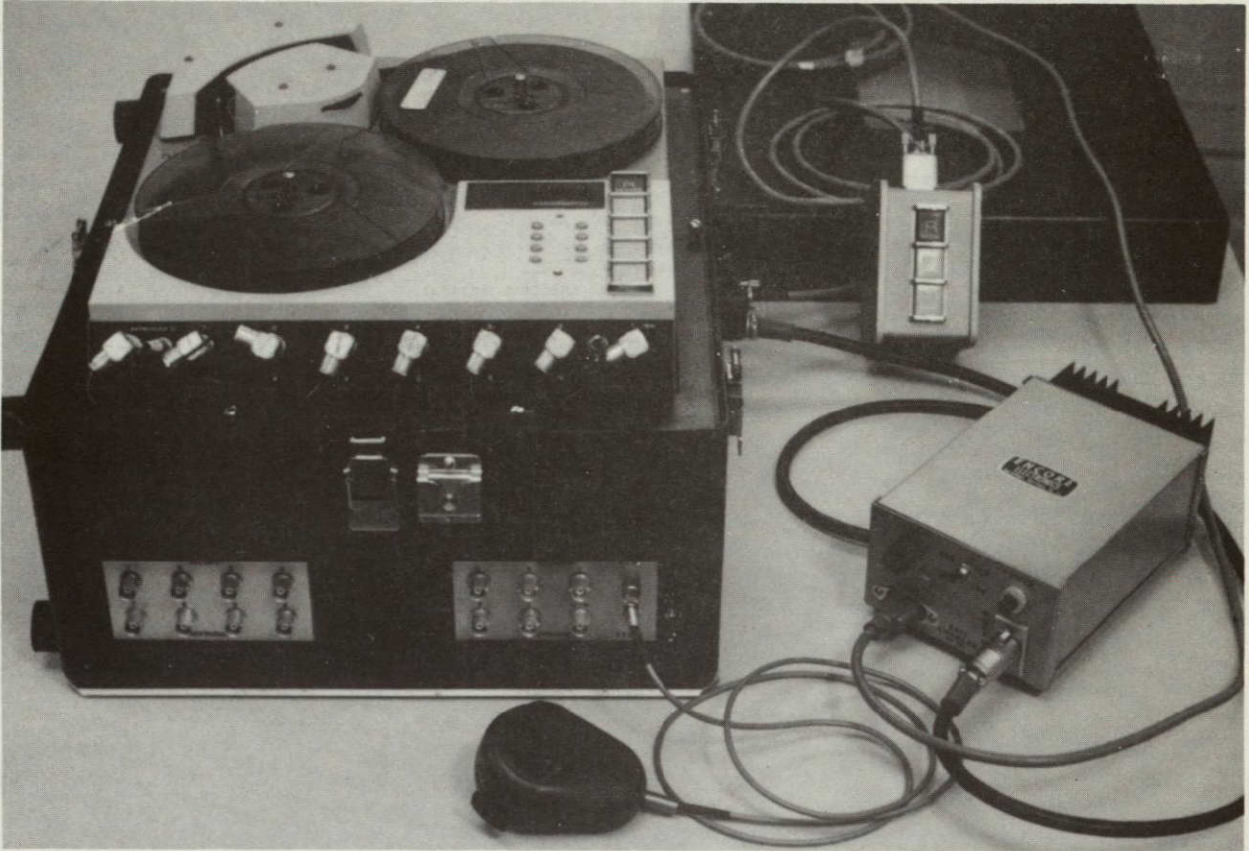

Figure 2.3.1
Mine Tape Recorder and Accessories

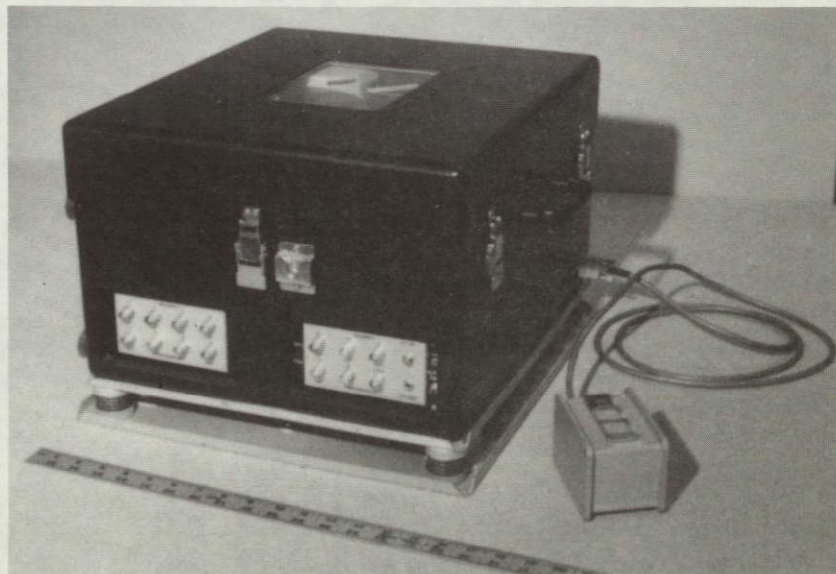

Figure 2.3.2
Shock Mounted Recorder

ORIGINAL PAGE IS
POOR QUALITY

in frequency response. A number of new 1/4 inch wide data tape recorders have been introduced in the last few years which have the frequency response and versatility required, but most are basically laboratory units which are not designed for the harsh test environment of a coal mine. Four data channels were also considered to be too few for complete coverage of machine performance studies. Size, weight, and power consumption are also excessive. The available one inch - 14 channel tape recorders also were rejected because of power consumption and weight considerations.

The Lockheed recorder was purchased with an optional double-deck environmental case which normally is used for a seven channel record/seven channel reproduce configuration. By not including the seven channel reproduce card rack, sufficient space was available for the special current limited battery pack to be mounted within the case. Figure 2.3.3 shows the battery pack mounting with the swing-up tape transport lifted. Also visible in this photo are several recorder plug-in electronics modules which permit selection of FM or Direct record or playback capability for each channel.

The battery assembly was purchased from Encore Electronics, Inc. of Saratoga Springs, New York, and it contains two solid-state current limiting devices in series which provide unique control of battery output current. A plot of output voltage versus current drain is shown as Figure 2.3.4 with a constant 19 volt input to the current control. Each half of the current limiter will pass the MESA cadmium wheel brush test for intrinsic safety. The unit can be short circuited continuously without damage and will recover immediately when load resistance values increase from short circuit to the regulating range of 15 ohms or more. The apparent operating resistance of the Lockheed recorder is 19 ohms.

The DC recorder drive motors present a problem during startup which was corrected by modification to the recorder's control circuit. When the Record control button is actuated the inrush current demand to the capstan and reel motors is very great. A safety feature of the Lockheed recorder

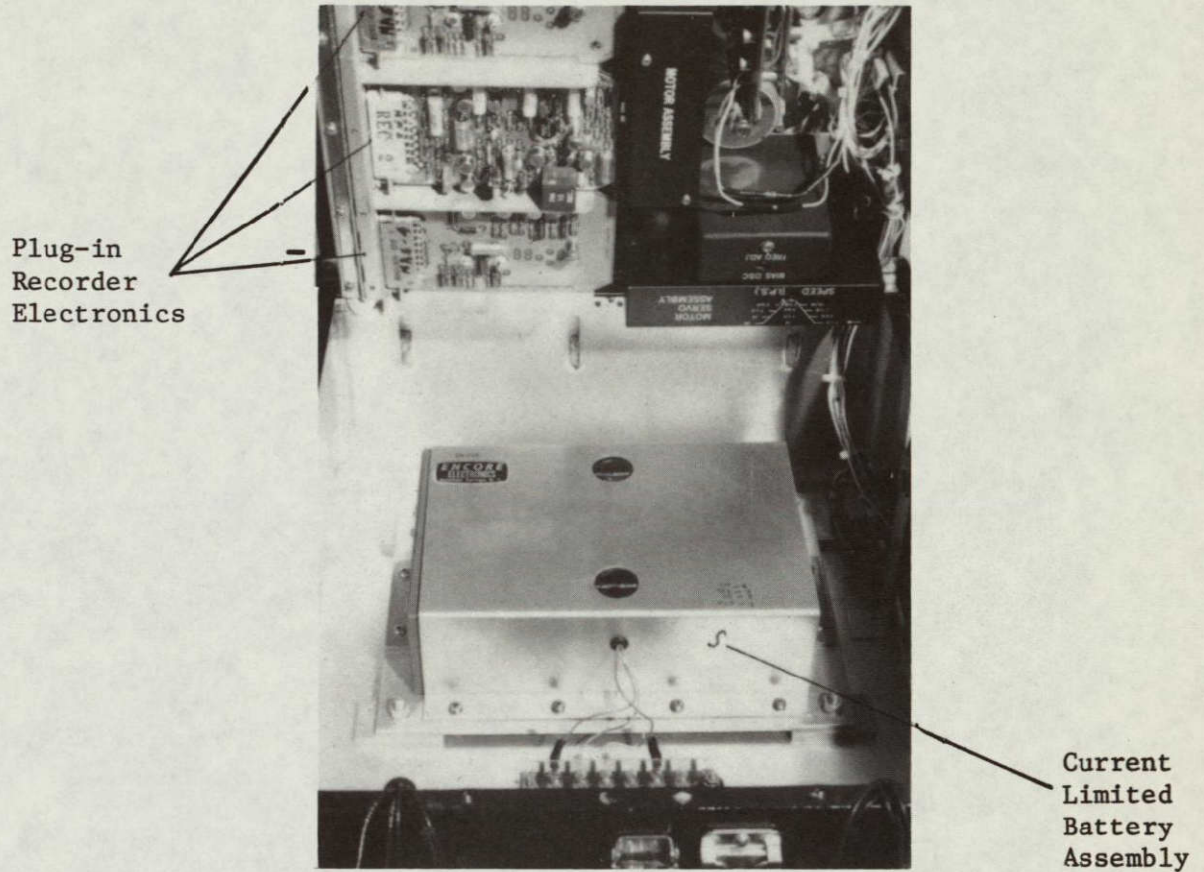
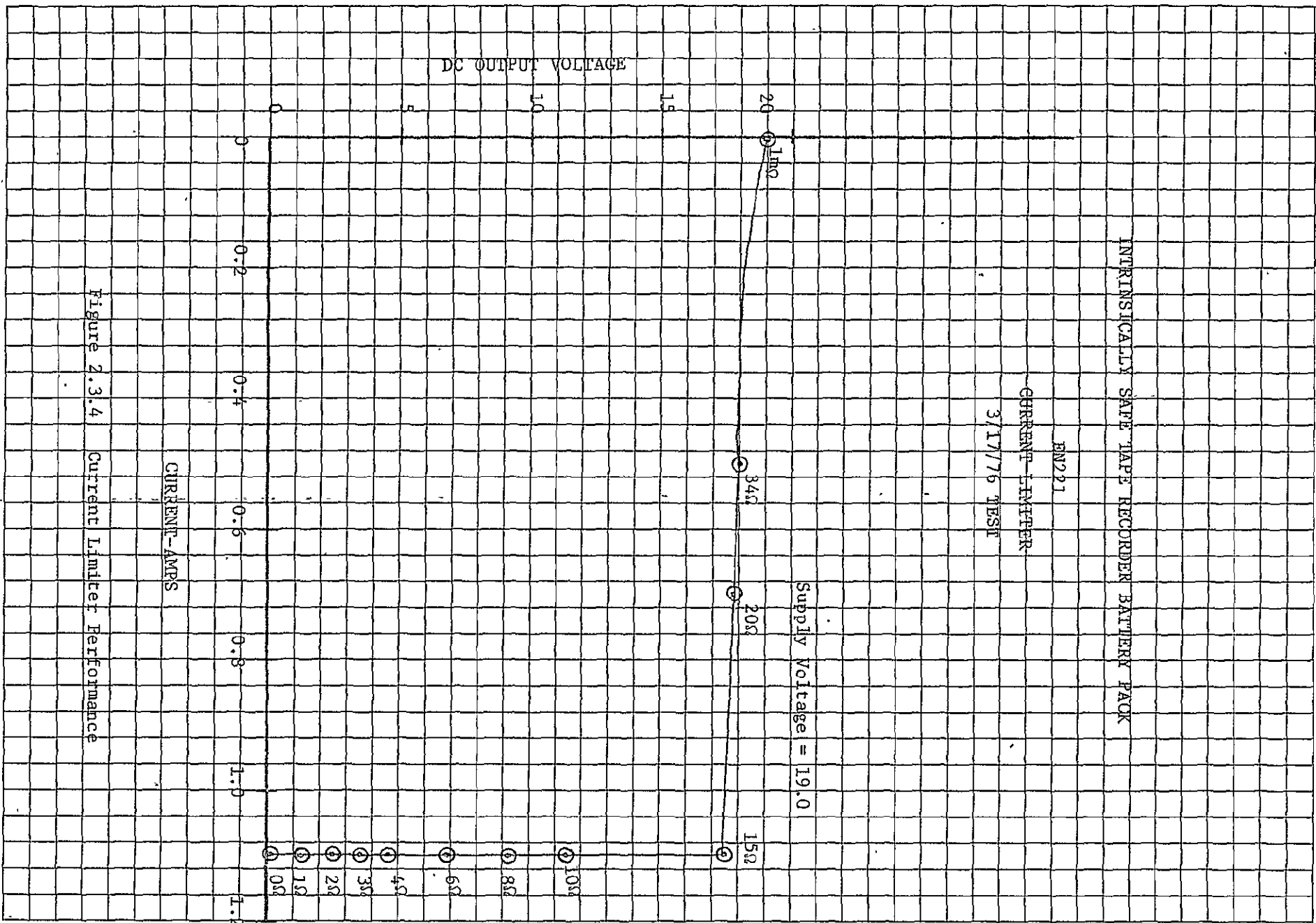

Figure 2.3.3 Tape Recorder Battery Mount



is a low voltage shut-off circuit which turns off the recorder when battery voltage drops to less than that necessary to provide stable and accurate recording (about 15 volts DC). Start-up demands exceed the cut-off level of the battery current limiter so the recorder would automatically turn itself off right after start initiation. The low voltage shut off could have been eliminated, but it provides a very useful function during data gathering so a temporary low voltage limit was incorporated instead to permit input voltage to go as low as six volts before shutting off the unit. After start-up current drains are satisfied the normal 16 volt limit is reinstalled to protect data recording integrity. The temporary limit change is provided by inserting a parallel resistor across the normal voltage adjustment resistor on the power supply card, using available momentary contacts in the recorder PLAY and RECORD pushbuttons. While the command button is held down, the voltage limit is six volts, but when the button is released the original limit is again selected. Modifications to the Lockheed recorder circuit are shown on Figure 2.3.5 which is also included as a supplement to the recorder Instruction Manual.

A plot of current limited battery output voltage versus time for a normal start is shown as Figure 2.3.6. At RECORD button contact the output voltage drops to approximately nine volts, recovers to 17 volts, and then falls again to 10 volts as the capstan motor is accelerated. A coarse speed control brings the capstan to near recording speed, is turned off, and then the phase comparator speed control takes over. After approximately eight seconds the recorder speed is stable and the current demands are reduced to a nominal 0.75 amp so the recorder pushbutton is released to return to normal low voltage shut-off limits. A review of start-up requirements with the recorder manufacturer gave assurance that no damage to motor or electronics equipment would occur with the temporarily reduced voltage condition, and only a slightly increased start-up time would be experienced.

The final tape recorder package weighs 46 pounds and is 15-1/4" wide, 17-3/8" deep, and 10-1/2" high. With the shock isolating mount in place, the package extends 12-1/2" above the mounting surface.

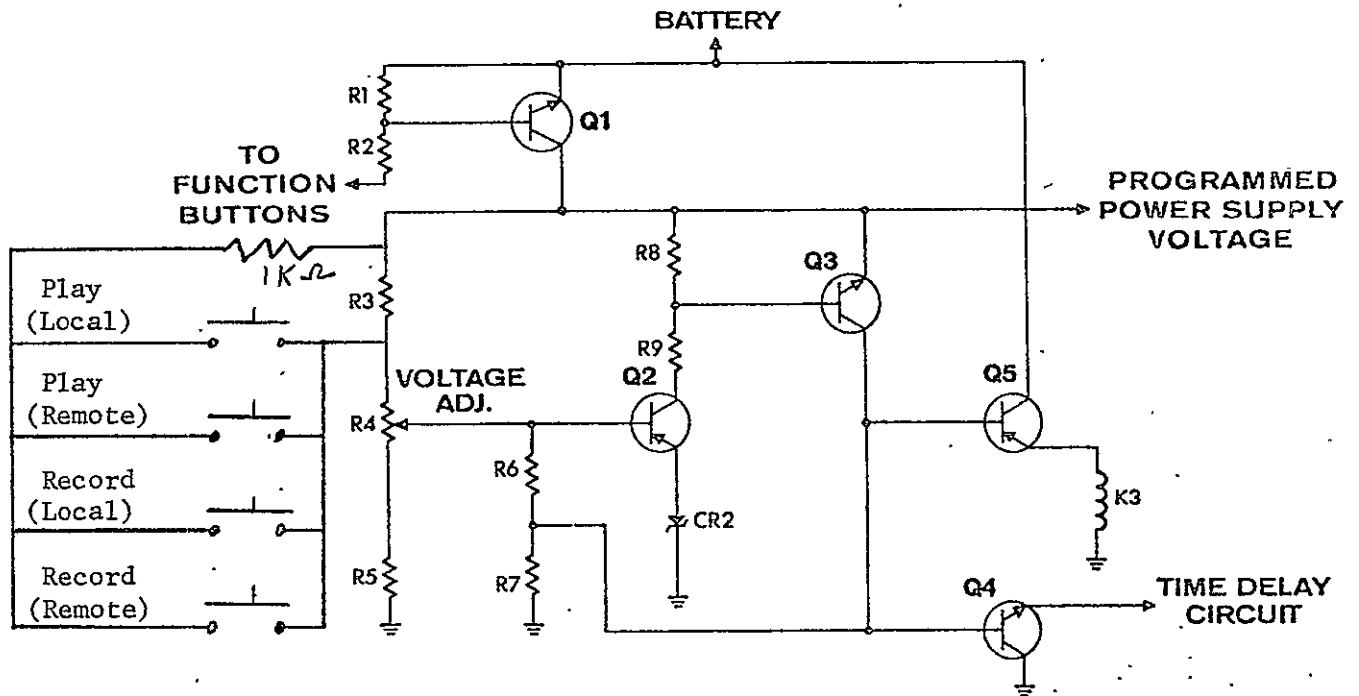
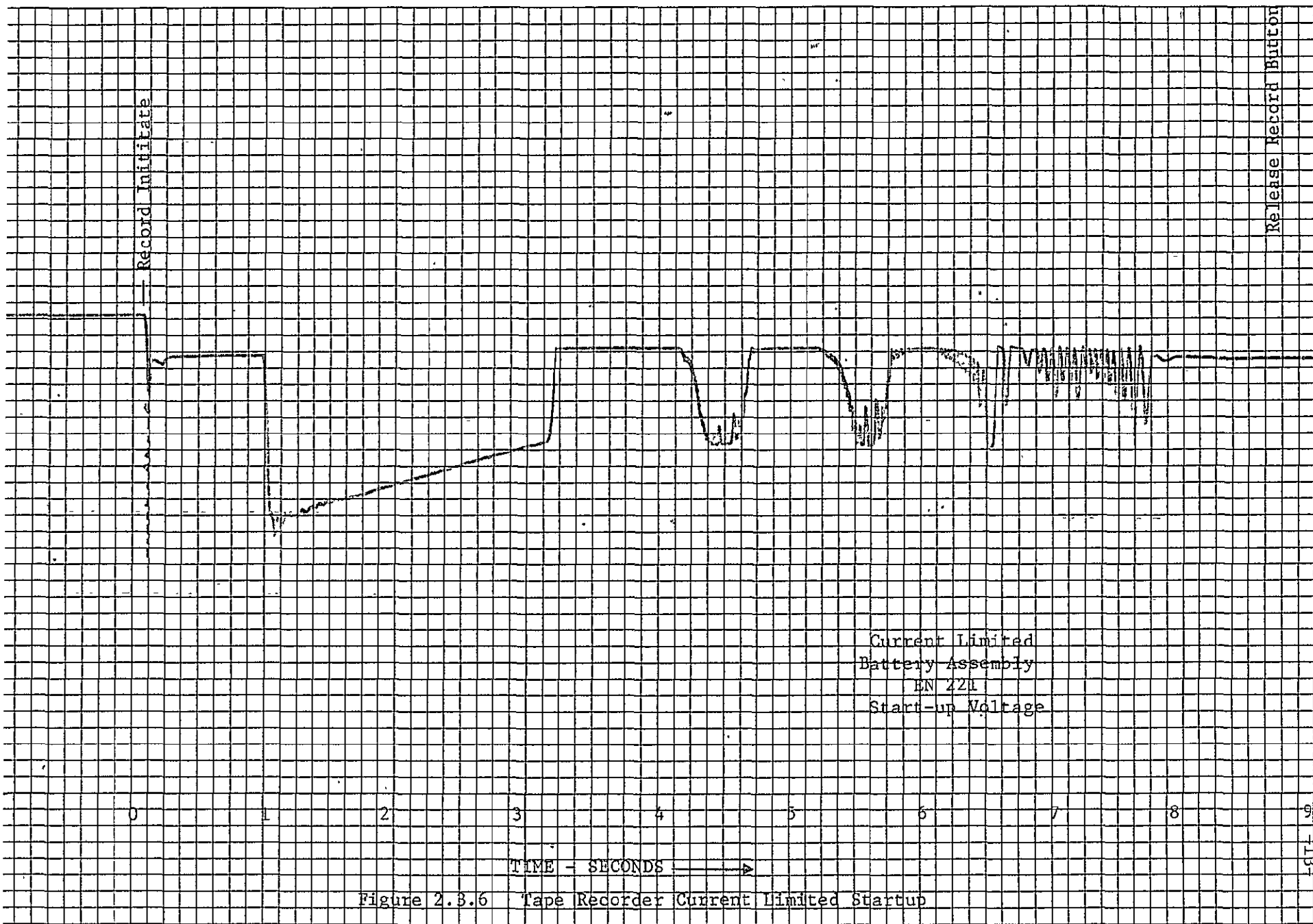

FIGURE 24 (Modified)

LOW VOLTAGE SHUTOFF SCHEMATIC

Modified Start Circuit

To facilitate startup of the Lockheed Tape Recorder with a current limited battery pack, a modification is incorporated to momentarily remove the low voltage shutoff circuit from consideration. During actuation of the Record pushbutton on the Play pushbutton (either recorder mounted or remote controls), a spare set of normally open contacts (N.O.) is used to set the Low Voltage shutoff threshold to 6 volts from the nominal 17 volts demanded by the Lockheed system. It is necessary to hold the pushbutton down until the initial inrush demand subsides, a period of from 2 to 8 seconds: if released too soon, the recorder will shut itself off because of low voltage and a restart can be initiated after the normal time out sequence. Remote closure is accomplished through unused cable connections F and K.



2.4 Data Amplifier System EN 211

The range of analog transducer signals which might be gathered with this data system goes from millivolt levels to tens of volts and from DC to near 100,000 Hz in frequency. Within this band it is practical to record signals which are representative of speed, displacement, acceleration, pressure, sound, time, angle, load, temperature, or other specialized response.

The basic signal conditioning assembly designed for this program is shown on Figure 2.4.1. Signal amplification is provided by six Encore Electronics Model 501 amplifiers which provide linear selectable amplitude control for gains of from X0.1 to X1000 for DC or AC test signals. Tape recorder inputs require signal levels near one volt RMS (plus or minus 1.4 volts about zero) so transducer outputs can be adjusted during test to give the required levels.

In addition to step gain control in a 1, 2, 5 array, a vernier is available for even finer level adjustment. Two single ended inputs are available for each amplifier - a 100K ohm input for gains of from X1 to X1000, and a 1 Meg ohm input for gains of X0.1 to X100. Either input can be AC or DC coupled. For AC coupling, the 100K input has a frequency range from 16 Hz to 100 KHz+, while the Meg input span is from 1.6 Hz to 30 KHz. For either input, DC coupling is available and an adjustable input DC offset is available to null out up to eight volts of positive or negative voltage.

Two signal conditioning capabilities are built into the amplitude assembly to provide power for a variety of transducers. Six voltage source channels regulated by constant current diodes to four milliamps can be used to power a broad range of quartz crystal pressure, acceleration, load, and sound ICP transducers with built-in electronics. Open circuit voltage is 18 volts while operating voltage with the ICP transducer in place is near 11 volts. To power displacement, pressure or position sensors, six +12 volt taps off the main amplifier battery supply are available from four pin Amp connectors, with common and signal return leads through to BNC connectors.

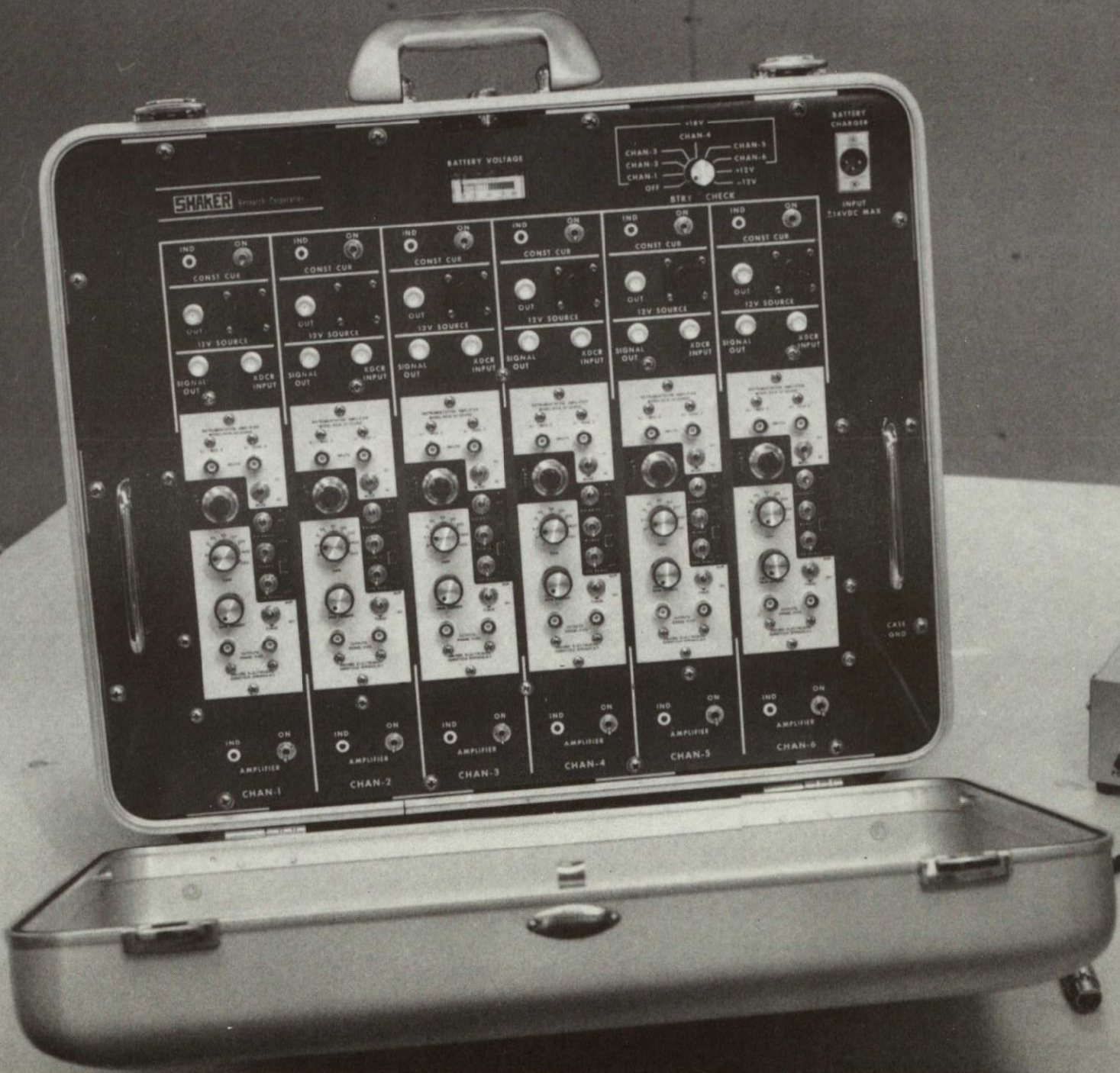

Figure 2.4.1 EN211 Data Amplifier Assembly

ORIGINAL PAGE IS
OF POOR QUALITY

The amplifier battery supply is made up of two 12-volt Gel/Cel[®] units with resistance current limiting for intrinsic safety requirements. The batteries and series wire-wound resistors are enclosed in aluminum, potted, and bolted to the amplifier support structure within the aluminum formed case. Separable hinges permit the front travel cover to be removed when the amplifier is in use. A completely charged battery provides 24-30 hours of amplifier operation, while the separate batteries for the constant current ICP supplies are used up after 250-300 hours of operation. The main battery assembly can be recharged in 14 hours using the 110 volt powered battery charger/operator. The amplifier unit can be operated while the batteries are being recharged with some penalty in charging time.

Overall package dimensions are 21" wide x 17" high x 15" deep (12" deep without the travel cover). Completed weight is 46 pounds.

2.5 Strain Amplifier System EN217

To provide for the unique requirements of strain gage excitation and amplification, a two channel unit packaged in the same size case as the data amplifier was assembled (see Figure 2.5.1). Encore Electronics Model 601 differential input amplifiers provide the required DC amplification of from X1 to X1000. Built into each amplifier are selectable low pass filters, 100 Hz to 30 KHz in steps, to minimize noise from strain signals. DC offset is available to permit static strains to be nulled out.

Gage excitation is of the constant current type which minimizes gage non-linearities from temperature and strain. It is anticipated that semiconductor strain gages will regularly be used, and the constant current excitation minimizes changes in apparent strain due to gage resistance variations with temperature and gage factor changes with temperature. Apparent strain is defined as that strain calculated from resistance changes produced by factors other than load-induced strain. Maximum compensation for these factors comes from the use of a Wheatstone bridge circuit with all four gages active as shown in Figure 2.5.2 where the gages are positioned so that strains in R_G and $R_{G \text{ comp.}}$ are opposite in polarity to produce a load responsive signal.

Figure 2.5.1 Strain Amplifier Assembly EN217

ORIGINAL PAGE IS
OF POOR QUALITY

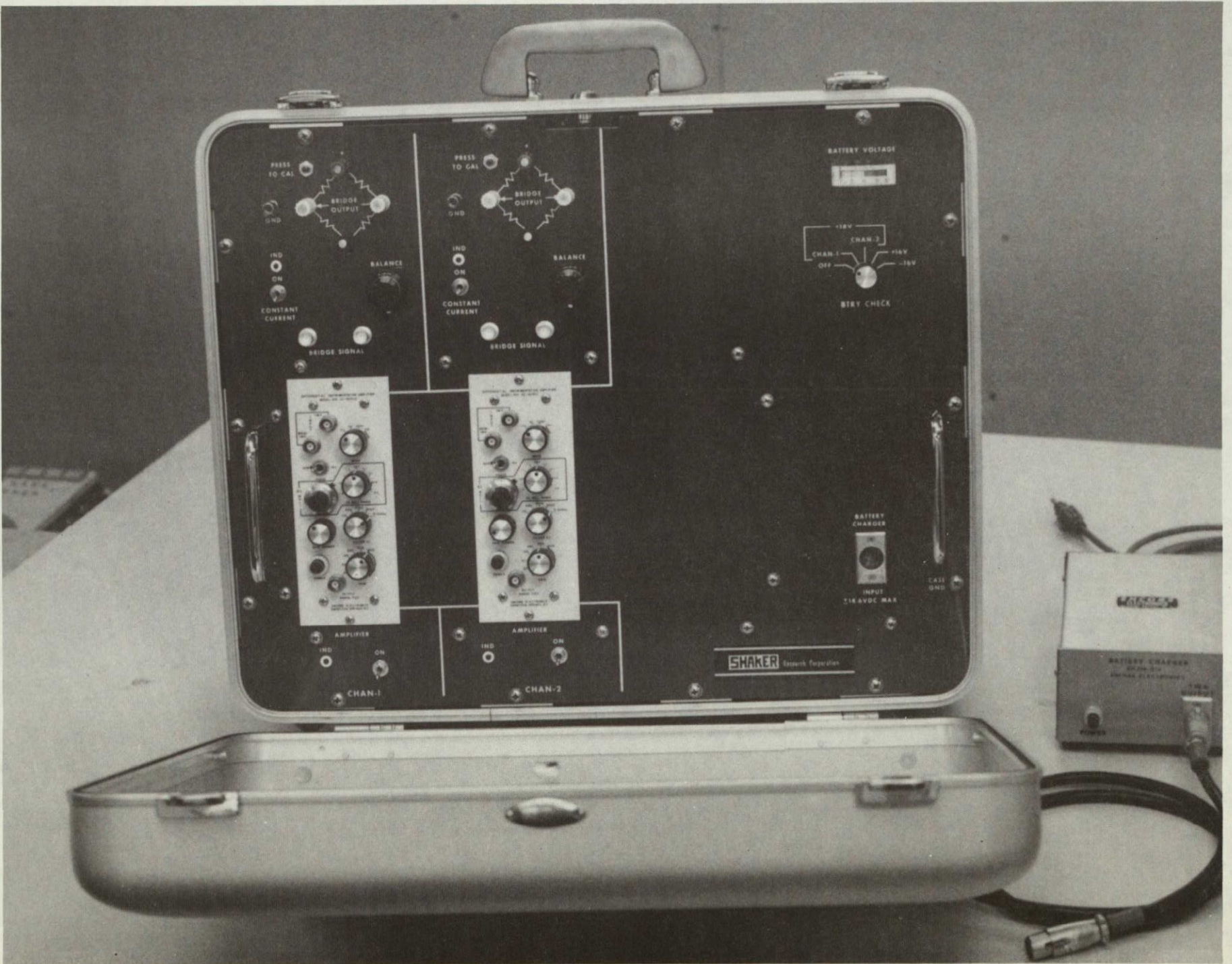

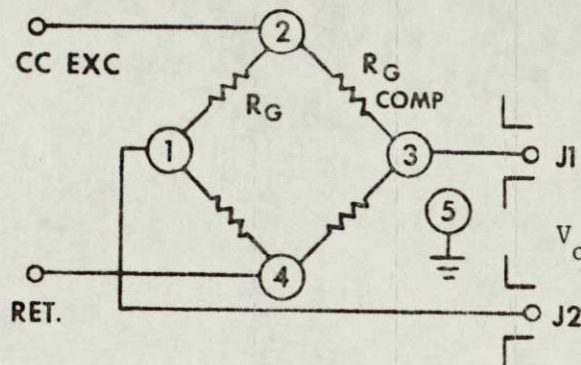

Wheatstone Bridge Strain Gage Circuit

Fig. 2.5.2

The output for this circuit is defined by: $V_o = \frac{EKRI N}{4}$

where E = strain

K = Gage Factor

R = Gage Resistance

I = Gage Current

N = Number of Active Gages

If extremely accurate static strain levels are not required, a configuration as shown on Figure 2.5.3 gives improved reliability and reduced installation difficulty using only one gage.

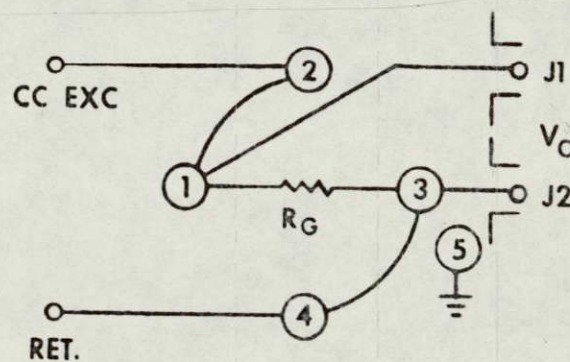

Strain Gage Circuit Using Only One Gage

Fig. 2.5.3

The output voltage for this configuration is given by: $V_o = EKRI$

To aid in setup, a shunt resistor can be placed across the constant current source to simulate a step strain change.

The constant current battery assemblies are the same potted units as are used for the data amplifier ICP supplies. The main rechargeable battery pack for the Encore 601 amplifiers is made up of four 8 volt Gel/Cel[®] units arranged to give plus and minus 16 volts. Series 25 ohm 5 watt wire-wound resistors provide current limiting for intrinsic safety compliance. Batteries and resistors are potted and enclosed in aluminum for protection.

2.6 Sound Measurement System

It was anticipated that in-mine evaluations of coal mining equipment would include the measurement of sound pressure level outputs for human exposure (OSHA compliance) and also for additional information about machine operating performance. A Bruel and Kjaer Type 2203 Precision Sound Level Meter with one-half inch diameter microphone Type 4133 is used to give broad frequency response, large dynamic range, compact dimensions and MESA approved safety. Figure 2.6.1 shows the complete sound measurement system and a compact carrying case.

It was originally planned that a Type 2209 sound level meter would be used to obtain even higher frequency response (to 100 KHz and above), but a very large electrolytic capacitor used for peak-hold evaluations cannot be made intrinsically safe so the unit has been neither approved nor permitted for gassey coal mine use.

A ten foot long extension cable (A00033) permits the microphone to be mounted away from the Type 2203 as typical operation places the meter near the tape recorder and test operator so that level adjustments can be made during mining machine operation. Insertion losses due to the extension cable and adaptors are taken care of by calibration adjustment, using the Type 4230 sound level calibrator to produce a 1000 Hz, 94dB sound pressure level reference at the microphone. Because it is battery powered, the calibrator also has MESA approval.

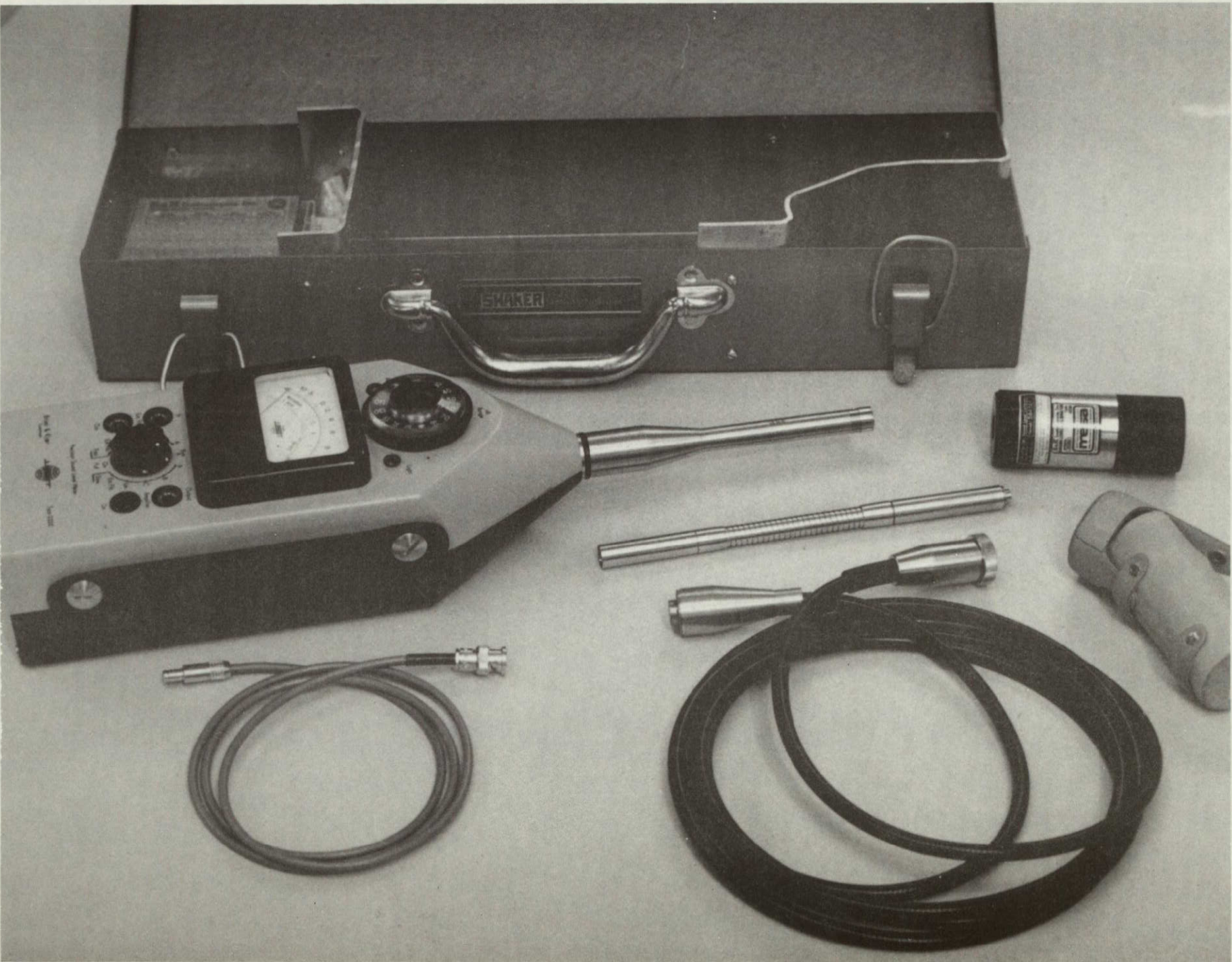

Figure 2.6.1 Sound Measurement System

ORIGINAL PAGE IS
OF POOR QUALITY

Two output voltages are available from the sound level meter: an AC data signal which includes sound pressure information covering a frequency range from 10 Hz to 40 KHz, and a DC level indication proportional to meter level for evaluations of sound level variations with time. Internal filters can be selected to provide A, B, or C weighing, in addition to a broad linear response position for all-pass. External octave and one-third octave filters can be installed if more detailed on-site evaluations are desired, but it was expected that tape recording of AC outputs would provide major sound records.

2.7 Transducer Selection

In order to provide the capability of defining general machine performance parameters, a number of transducers were selected based upon versatility and probable need. In several instances the transducer models are the same as those used regularly by Shaker Research Corporation in field machinery troubleshooting assignments.

2.7.1 Low Frequency Acceleration

Measurement of machinery vibration characteristics in the low to moderate frequency range is best accomplished using accelerometers with built-in signal electronics to produce high sensitivity and low noise in a compact element. Units manufactured by PCB, Inc. of Buffalo, N.Y. were selected to provide response from 1 Hz to 3000 Hz and 50 mv per G sensitivity. These are powered by constant current power sources built into the data amplifier assembly so up to six units can be used simultaneously. The built-in signal electronics eliminates the influence of connecting lead length on accelerometer output sensitivity at the expense of somewhat reduced temperature upper limit, but for mine use the 250°F allowable level is most acceptable. The accelerometers usually are stud mounted using a 10-32 threaded hole in the base, either by drilling and tapping the desired machine location or by cementing on a mounting pad which already contains the 10-32 mounting thread. Use of a brittle cement such as Eastman 910 permits quick attachment with good vibration transmission characteristics. These accelerometers are 0.75" in diameter, 1.07" high, and weigh 55 grams.

In normal use, a low noise co-axial cable is connected to the constant current source output (BNC) and to the accelerometer Microdot connector. When the constant current supply is turned on, the panel battery voltmeter can be used as a go no-go system fault indicator, as a normal hook-up gives 11 volts, a shorted accelerometer or cable gives 0 volts, and an open cable or accelerometer will give 16-18 volts. Battery current is transmitted to the accelerometer over the same conductors that return the acceleration signals. A 1µf capacitor is connected in series with the output so that the transducer signal BNC connector does not contain the 11 volt DC offset.

2.7.2 High Frequency Acceleration

A number of machinery diagnostics techniques have been developed in recent years based upon vibration signals measured in the near ultrasonic region. Pump wear, rolling element bearing spall detection, gear deterioration, and pump cavitation have all been detected well ahead of conventional means by evaluating data in the 15 KHz to 50 KHz frequency band. To explore that test region, miniature accelerometers by Bruel and Kjaer, Model 4344, were selected for this field package. Individual units selected for high frequency linear output allow data gathering to 40 KHz with good accuracy. As with the PCB accelerometers, mounting is with a stud, either by direct drill and tap for the 3mm thread or by cementing on a mounting plate with the 3mm thread in it. Measurement of high frequency data requires considerable care to avoid errors from improper mounting so particular attention to mounting torque, thread squareness, and cable attachment are required.

The high impedance output signal of the piezoelectric crystal is converted to a low impedance signal by the use of a voltage follower by PCB, Inc., a Model 402A11. These unity gain amplifiers are installed between the accelerometer output cable (3 feet long) and the accelerometer extension cable (15 feet long). The voltage sensitivity of these accelerometers is nominally 3 mv per G. Power for the voltage followers also comes from the constant current supplies of the data amplifier assembly. The four milliamp supply current can operate the follower with greater than 100 feet of co-axial extension cable without signal strength loss.

2.7.3 Pressure Transducers

Measurement of pressures for machinery control development requires a broad range of transducer performance which cannot be met with a single sensor design. Sensors with the response capability for dynamic pressure evaluations such as the quartz crystal type do not have the ability to detect steady state or continuous pressure values. Sensors with DC capability such as the strain gage type, typically do not respond to fluctuating pressure conditions at greater than 100 Hz. For this equipment system, a compromise transducer was selected for general use, and the capability to accept alternate systems is available. The transducers selected are made by National Semiconductor and are of the integrated circuit type. This transducer design has a Wheatstone bridge and associated circuitry etched on the semiconductor element which is directly loaded by the working fluid. Output voltage for 12 volt excitation is from 0 to 10 volts DC, proportional to rated pressure. Two 3000 psi units were purchased for this program, and during bench tests gave outputs as shown on Figure 2.7.1. The manufacturer does not spec transducer frequency response, but these devices can be used as microphones for the voice range (up to 5000 Hz) so step input signal rise times are very short. The four pin Amp connectors on the data amplifier front panel provide the necessary 12 volt unregulated input voltage and a signal return line to a BNC connector for up to six transducers.

For dynamic pressure measurement requirements under high temperature or extremely high frequencies, the constant current source supplies can be used with quartz pressure transducers and voltage followers as for the B&K accelerometers, or with quartz transducers with built-in electronics such as provided by PCB, Inc. or Kistler. Also, strain gage type pressure transducers can also be excited using the strain gage amplifier assembly.

 5-X 5-TO-THE CENTIMETER 46 1612
18 X 24 CM
MADE IN U.S.A.
KEUFFEL & ESSER CO

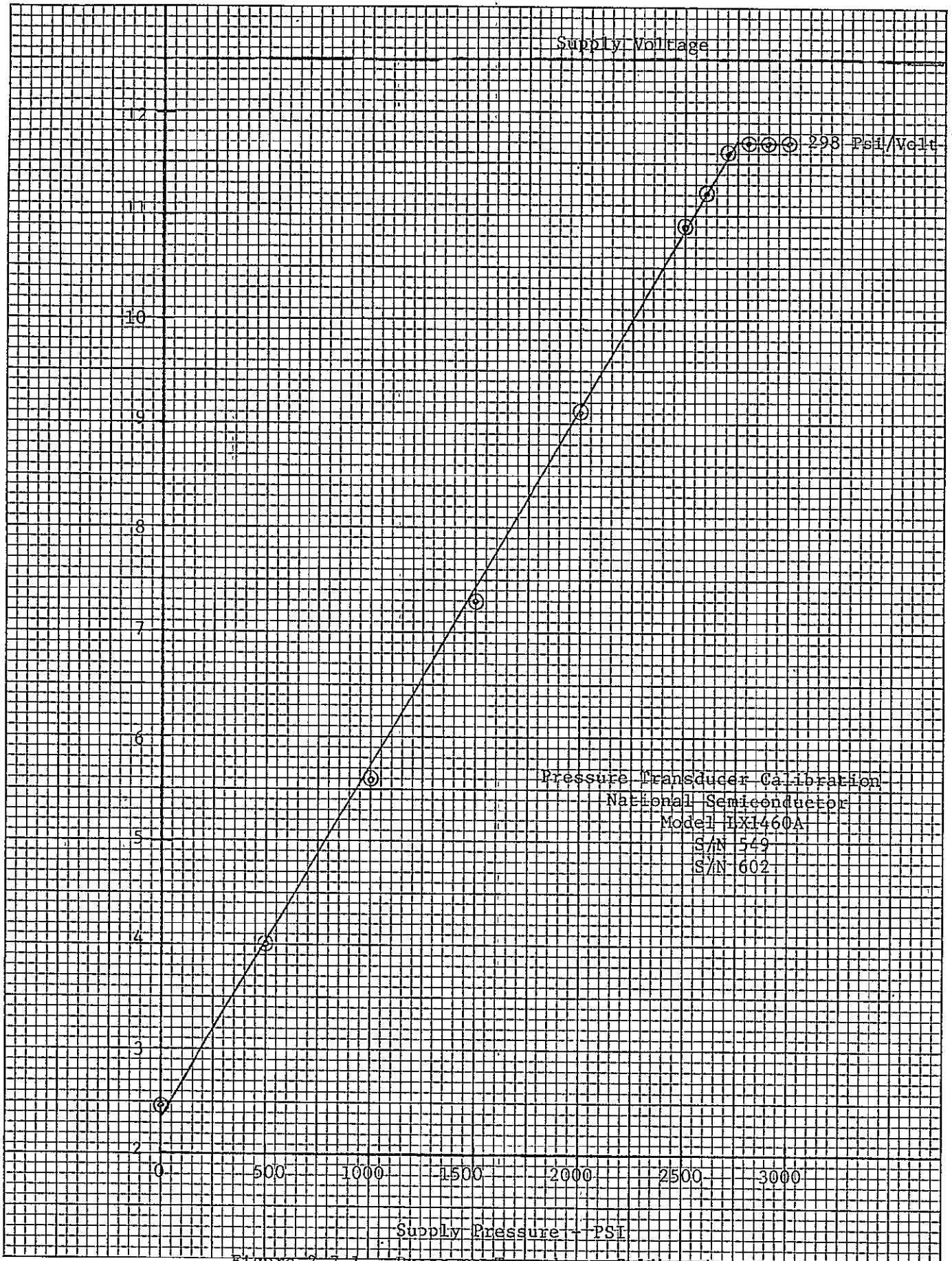

Figure 2.7.1 Pressure Transducer Calibration

2.7.4 . Strain Gages

It was anticipated that typical strain measurements would be of moderately stressed machine elements, such as drum ranging arm structure, hydraulic cylinder rods, or control lever shank so sensitivity would be a problem. Therefore, semiconductor strain gages by Kulite or J. P. Semiconductors, Inc. are suggested with gage resistance values of 350 ohms and typical gage factor of 135. The extremely high output of these gages allows reasonable output for low microstrains and gives significant margin for the very difficult test environment of an operating coal mine. The high signal-to-noise ratio from such high output sensors permits additional latitude in gain setting when the absolute strain level cannot be readily predicted. Constant current excitation should be specified when ordering gages so the optimum gage crystal can be provided.

Traditional foil gages can be applied as well with this equipment with the typical output reduction of $\frac{1}{70}$. (Gage factor = 2.0 rather than = 135.)

2.7.5 Temperature Measurement

No specific sensors were selected but semiconductor temperature sensors can be used with the strain gage bridge circuitry to provide temperature measurement over a range of from -100°F to $+350^{\circ}\text{F}$. Also, the same family of transducers as are specified for pressure (from National Semiconductor) can be purchased for temperature measurement.

2.8 Mine Data Review Instrumentation

During setup, calibration, and operation, measurement capability is required to insure first of all that transducers are functioning but also that signal levels are within the required range for tape recording. The FM record channels can accept data signals between +1.4 volts to -1.4 volts, with those limits including both AC and DC voltage extremes. As an example, a pressure signal might be set at -1.40 volts at zero psi and then move to +1.00 volt at normal running. If pressure fluctuations are occurring, they will result in a signal which varies with time around the +1.00 volt DC position. If the variation exceeds ± 0.4 volts AC, there is risk in saturating that recorder channel in the positive direction

and losing information. All the data amplifiers used in this test assembly can be set for AC or DC response so that both dynamic and static voltage levels can be conditioned. In the DC mode, each amplifier has an adjustable bias capability which permits the input to be offset at least ± 10 volts. This allows positioning of pressure or strain data into the range of the tape recorder so that maximum resolution can be attained. The optimum monitoring capability for data recording is provided by a two channel oscilloscope, but intrinsic safety requirements will only allow such devices if enclosed in an explosion-proof case with an approved viewing window. The weight and bulk of such a package is excessive so an alternate monitor was selected for this instrumentation package, a liquid crystal display digital multimeter by Dana, Model 2100 Danameter II. This unit has measurement capability of DC levels of one millivolt to 1000 volts, AC levels from one millivolt to 700 volts rms, resistance measurement of from one ohm to 19.99 meg ohms, and DC current measurement of from ten nanoamps to two amps. The liquid crystal indicator system requires only minimal power so a carbon zinc nine volt transistor radio battery will give up to one year of use before replacement is required. MESA safety requirements are met by Approval Number 2G2884.

Light from a miner's lantern illuminates a highly visible 3-1/2 digit display, but there is no internal light source within the liquid crystal element.

Normal use of the multimeter for setup would be to check continuity for cables and leads, to evaluate resistance to ground for circuits or transducer mounts, or to troubleshoot battery systems. During calibration, step changes in pressure or strain will produce a corresponding DC output change which will indicate something near normal results which will be seen during operation. A typical example would be for strain measurements of a longwall ranging arm to determine cutting force variation. A tensile fiber strain gage on the upper arm surface could be loaded by picking up the drum from a position with the drum resting on the pan to

one with the drum suspended. The weight of the drum assembly will produce a strain indication as much as one half the amplitude one might expect during cutting. The bridge circuit can be balanced initially and the amplifier gain and offset adjusted so that levels would be proper for tape recording. Similarly, pressure transducer output without and with a hydraulic pump operating will give good indication of levels to be experienced during test.

While test recording is under way, the multimeter can be used to judge gain settings for pressure, strain, and accelerometer amplifiers using AC levels. Gains typically are adjusted during normal operation to 0.2 to 0.5 volts rms so that sufficient range remains for unusual operating peaks.

2.9 Out-of-Mine Data Review

Use of meter indications for tape recorder input definition does increase the risk of data loss in the event of transducer problems as noise can give responses similar to test data. To guard against serious test data loss, a portable two-channel oscilloscope was added to the data system for use outside the mine in reviewing recorded signal levels. The Model 212 oscilloscope by Tektronix is small enough to easily be packed for travel, but provides reasonable data viewing for two channels of recorded information. A scan of response data before leaving the vicinity of the coal mine insures that the character of the test data is at least reasonable and that a repeat test is not necessary.

3.0 DRUM DATA TRANSMISSION REVIEW

A portion of the original program was to review the possibilities of installing slip-rings on the drum of a longwall shearer to transfer test data from a drum cutting bit to a main frame mounted instrumentation system. Possible designs included the use of a NASA supplied multichannel slip-ring assembly for centerline mounting, and an add-on rim type slip-ring mounted on the face of the drum.

It was found that the dead axle type drum support universally used eliminates the possibility of a centerline mount slip-ring. Also, many manufacturers make available a drum water spray system which ports water through the dead axle and out into the drum hub in the region where an internal hub slip-ring might be mounted between support bearings. This further complicates installation.

A face type slip-ring mounted on the machine side of the drum could be applied, but would be subject to extremes of abrasion and water contaminations. Also, the axial space between drum and ranging arm is very limited and restricted by the support for the slewable cowl. The overall conclusion of the review was that a slip-ring system could be designed into a new machine but would be extremely difficult to retrofit to an existing machine during a complete disassembly. Installation of a slip-ring with less than complete machine-shop access is almost impossible.

Based upon these conclusions, it was recommended that the slip-ring concept be put aside until experimental data is gathered to resolve questions of data transmission requirements. It was further recommended that a drum-mounted telemetry system be designed to permit the necessary experimental data to be gathered. The original program contract was modified to include the design of this data transmission system which could be used to process sensitized pick coal interface detector (CID) data from an operating mining machine. The results of that study are described in Appendix A to this report, "Design Report - Wireless Data Transmission System for Sensitized Pick Coal Interface Detector on Longwall Mining Machines", by R. F. Burchill and W. D. Waldron.

4.0 MINE TEST SITE REVIEW

Selection of a mine test site for preliminary evaluation of mining machine performance proved to be a difficult problem with the proposed test site changing several times during the program. The initial location selected was the Kaiser Steel Corporation - York Canyon mine at Raton, New Mexico, but that longwall face became unavailable because of production schedules. The sensitized pick CID data transmission design program included visits to a number of mine sites to review installation requirements and that review led to an invitation to test in the Jane mine of Rochester and Pittsburgh Coal Company, Indiana, Pennsylvania. Use of electronics equipment in a Pennsylvania coal mine required a review by the Pennsylvania Office of Deep Mine Safety of the proposed test package. The initial step in obtaining this approval was a request to the Office of Deep Mine Safety, Walter J. Vicinelly, Commissioner, for the required review. He, in turn, requested that the Director of Bituminous Deep Mine Safety, Mr. Dennis Keenan, appoint a committee of Bituminous Underground Mine Inspectors and Electrical Inspectors who would conduct an investigation as to the safety of this equipment for mine use. The Committee members were Mr. John E. Pringle, Bituminous Electrical Inspector, Mr. Michael Anderson, Bituminous Electrical Inspector, and Mr. Anthony E. Valeri, Mine Inspector. Mr. Richard F. Burchill, Shaker Research Corporation and Mr. John Burch of NASA met with Mr. Keenan and the Committee in Ebensburg, Pennsylvania to demonstrate the equipment package. Based upon that review, a letter of approval was issued to allow this equipment to be used for test purposes in Pennsylvania underground Bituminous coal mines.

A number of serious roof control problems resulted in the abandonment of the longwall face planned for test in the Jane mine so testing finally took place in the Kopperston No. 2 mine of Eastern Associated Coal Corporation at Kopperston, West Virginia, on June 9 and 10, 1977.

5.0 MINE DEMONSTRATION TEST

Application of the mine data gathering system in a functioning longwall installation had three primary purposes: to demonstrate that the components could function to produce performance data in the difficult environment of an operating mine, to obtain baseline operating data from a typical installation, and to comply with the MESA requirement that the group obtaining an intrinsic safety permit be first to apply the permitted equipment. Not all of the capabilities of the instrumentation system were to be demonstrated as it was intended that minimum interference with normal production be a primary consideration, and insertion of transducers into the control or load circuits of the mining machine would involve significant time, effort and risk.

5.1 Mine Test Location

The test site was obtained through Joy Manufacturing Company with the aid of Mr. Richard L. Breithaupt and Mr. Carl A. Erickson. The test site was a training face established by Joy and by Eastern Associated Coal Corporation at the Kopperston No. 2 mine, thirty-five miles west of Beckley, West Virginia, to evaluate specific operating characteristics of longwall mining while training crews in anticipation of delivery of a new longwall installation being supplied by Joy Manufacturing Company. Mr. J. C. Barber, District Sales and Service representative for Joy, provided liaison with mine management and also acted as guide and test helper during the two days spent underground.

5.2 Mine Description

The longwall panel at Kopperston is 200 feet long and has 450-500 feet of overburden. The metallurgical grade coal seam is made up of a nominal 48 inch thick upper area, a rock layer eight to ten inches thick, and a lower coal seam 10 - 12 inches thick. Because of dust control, a full cut is taken only when traveling from right to left (when viewing face), the direction of air flow and coal flow. This means that the left-hand drum takes a full cut when it is at the ceiling and while moving left, while the right-hand drum only cleans up the floor while the mining machine moves left, and only cleans up the face and ceiling while the machine trams right. Production is during first shift only

and operation has been almost exclusively with one crew. Although many double-drum shearers use two operators, one for the lead drum and one for the trailing drum, normally this unit has been controlled by only a single operator. This most likely has been practical because of the fairly moderate tramming speeds of from 10 to 12 feet per minute. It appears that the production rate of the longwall has been restricted by coal handling capability downstream of the face conveyor as most of the delays were from conveyor stoppage rather than from face problems. Ultimate coal delivery from the mine is by shuttle cars.

5.3 Test Equipment Installation

The test equipment assembly as shown on Figure 5.3.1 in traveling configuration was brought to the face area with the operating crew on Friday, June 10, 1977. Vibration mounts had been attached to the mining machine chassis on June 9 so that the amplifier assembly and tape recorder could quickly be attached to the upper body of the Joy Model 235 shearer, to the left of centerline of the machine to stay clear of the operator's station. Figure 5.3.2 is a photograph of the amplifier and recorder installation in the mine, while Figure 5.3.3 shows the same equipment mounted on its vibration mounts in the laboratory.

Selection of transducers and transducer mounting locations was made to define, as well as possible, the sound and vibration of the mining machine as normal mining takes place. The sensor locations shown on Figure 5.3.4 were selected to give reasonable rigid body platform vibration modes, high frequency responses from cutting on the ranging arms, and broad frequency noise measurement of pick cutting action. Table V-1 reviews in detail each sensor data conditioning.

5.4 Test Data Review

Test recording began at about 9:00 a.m. and was completed by 10:40 a.m. During this time, seven channels of data plus voice track commentary were recorded on magnetic tape, with a total record length of approximately 51 minutes. The tape was shut off several times when delays in the mining process occurred.



Figure 5.3.1 Mine Test Equipment Travel Configuration

ORIGINAL PAGE IS
OF POOR QUALITY

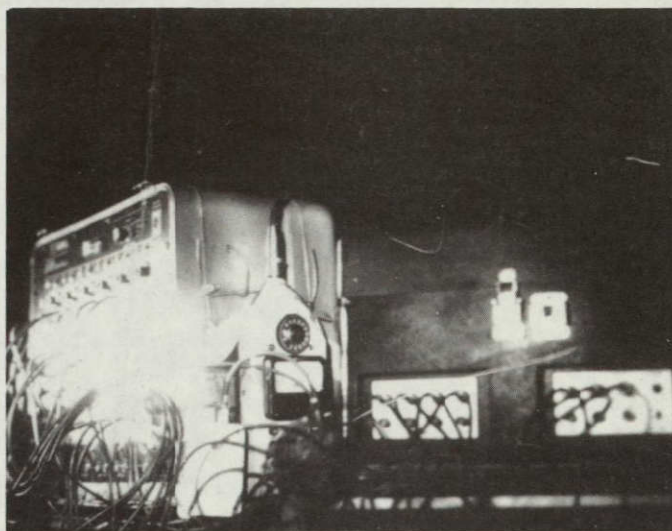

Figure 5.3.2

Mine Equipment Installation
In Kopperston #2

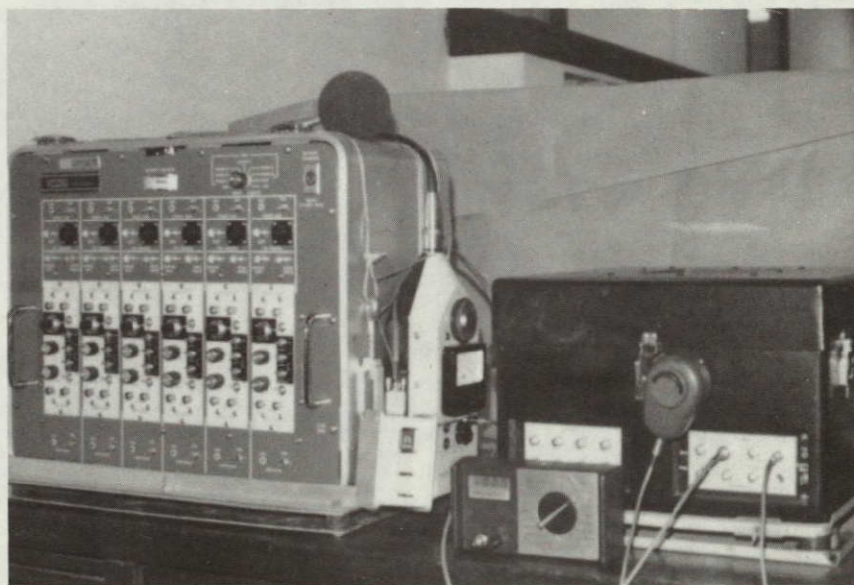
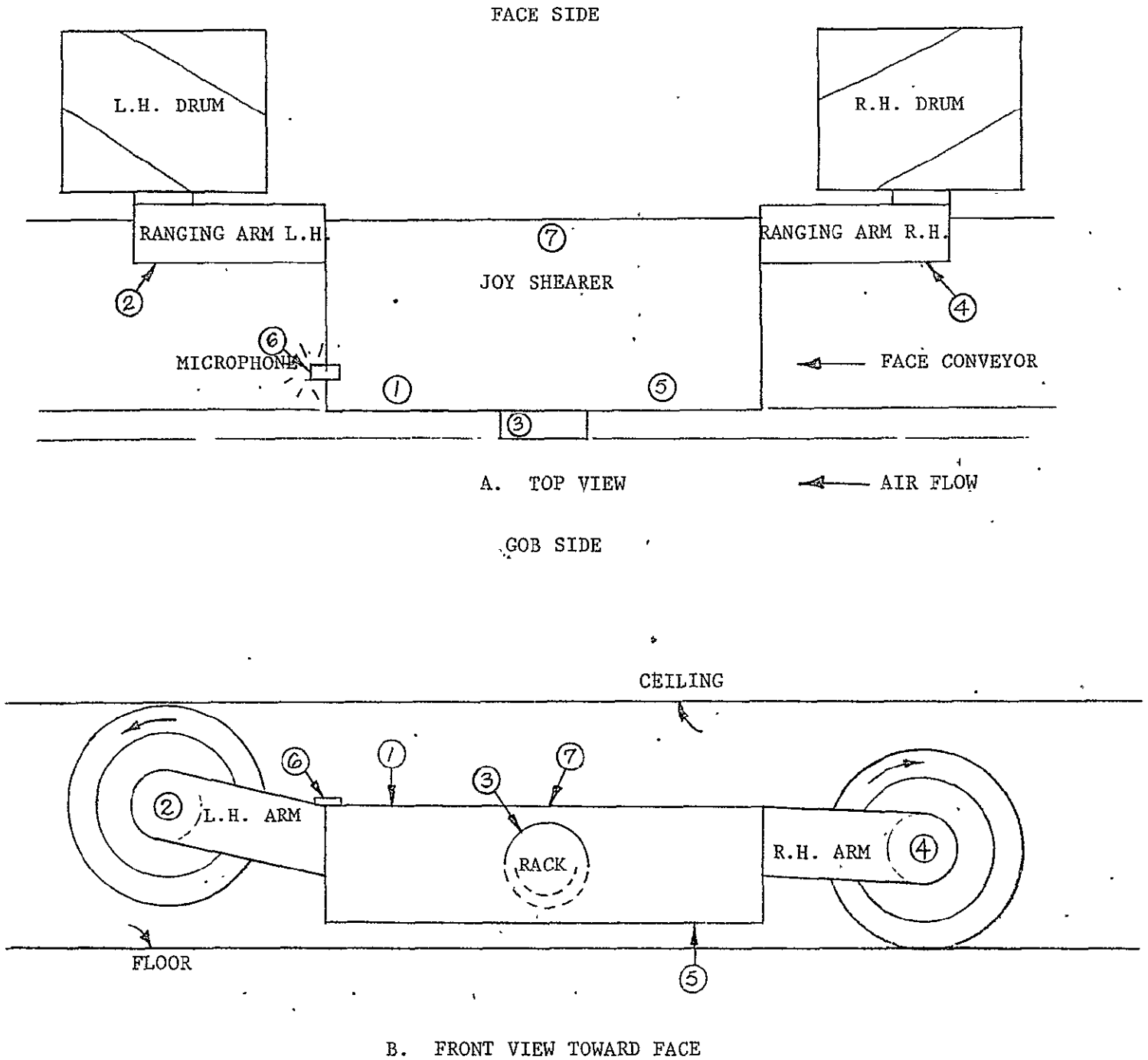

Figure 5.3.3

Mine Equipment Installation
Bench Simulation



Note: Accelerometers are stud mounted to tapped pads attached by Eastman 910 cement to shearer structure.

Figure 5.3.4
Sensor Locations - Joy Shearer

TABLE V-1

Mine Test Sensors
 Joy Longwall Shearer
 Kopperston #2 Mine - Kopperston, West Virginia

Tape #169 Lockheed Electronics Recorder 15 ips tape speed
 Tape #170

Sensor Location Description

Loc. 1	Vertical Main Frame Accelerometer PCB 308A03 Left-hand Upper Frame Encore 501-1 Meg Input Gob Side FM Record Channel 1
Loc. 2	Axial Ranging Arm Acceleration B&K 4344 Left-hand Drum (Prime) Encore 501-2 100K Input Direct Record Channel 2
Loc. 3	45° Drive Sprocket Accelerometer PCB 308A03 Encore 501-3 Amp Meg Input Gob Side FM Record Channel 3
Loc. 4	Axial Ranging Arm Acceleration B&K 4344 Right-hand Drum (clean-up drum) Encore 501-4 100K Input Direct Record Channel 4
Loc. 5	Vertical Shoe Accelerometer PCB 308A03 Right-hand Side Lower Frame Encore 501-5 Meg Input GOB Side FM Record Channel 5
Loc. 6	Left-hand Drum Sound B&K 1/2" Microphone with 2203 SLM Microphone at Left-hand Edge of Main Frame Horizontal Aimed Toward Left-hand Entry Direct Record Channel 6
Loc. 7	Face Side Main Frame Acceleration Vertical PCB 308A03 Center of Machine (nominal) beside Venturi Encore 501-6 Amp Meg Input FM Record Channel 7
V.T.	Voice Commentary of Test Conditions

Notes: 100 K Encore Input AC 16 Hz \longrightarrow 100 KHz
Meg Encore Input AC 1.6 Hz \longrightarrow 30 KHz
Accelerometers Stud Mounted on Cemented Blocks using
Eastman 910 cement.

During this series, examples were recorded of normal full load cutting, light load tramming, idle, and shutdown. One channel malfunctioned (Tape Channel No. 1) due apparently to a poorly made Microdot cable connection, but in general a good cross-section of machine performance was obtained. In order to provide an overall view of sensor performance, a plot of amplitude versus time was made for each functioning accelerometer channel and these are included as follows:

- Figure 5.4.1 Tape Channel No. 2 Left-hand drum, axial acceleration
100 Hz to 50,000 Hz
- Figure 5.4.2 Tape Channel No. 3 Drive sprocket cover
45° acceleration, 2 Hz to 5,000 Hz
- Figure 5.4.3 Tape Channel no. 4 Right-hand drum, axial acceleration
100 Hz to 50,000 Hz
- Figure 5.4.4 Tape Channel No. 5 Right-hand frame, vertical
acceleration, 2 Hz to 5,000 Hz
- Figure 5.4.5 Tape Channel No. 7 Face side frame, vertical
acceleration, 2 Hz to 5,000 Hz

Overall signal levels from each channel were fed in turn to a high quality AC voltmeter (Hewlett Packard 400E) which had a DC output proportional to the average AC input level from 5 Hz to 100 KHz. This presentation shows at least the character of the vibration data but, of course, contains no frequency analysis. The voice annotation on the tape was used to keep track of amplifier gain settings as written notes are difficult to keep - paper gets very smudged and one often needs the use of his hands to keep from falling or to adjust the test array. A number of voice notes are added to the time data plots to permit later comparison with tape data during additional analysis.

A preliminary review of output spectrum analysis plots indicated that much of the FM channel data was at low frequencies so an additional set of plots was recorded of the output of Channel 3, Channel 5, and Channel 7 which were passed through an electronic double integrator to produce voltage proportional to

displacement values. The double integrator used was a proportional one from 6 Hz to greater than 1,000 Hz and produced a flat response below 6 Hz so that DC swings did not drive the integrator output to infinity. By comparing the integrated output level plots with the acceleration plots, it is possible to determine whether high frequency or low frequency components dominate the vibration response.

Overall acceleration data integrated to produce displacement data are plotted on the following figures:

Figure 5.4.6 Tape Channel 3 Drive sprocket cover 45° displacement in mils peak-to-peak (1 mil = 0.001 inch)

Figure 5.4.7 Tape Channel 5 Right-hand frame vertical displacement in mils peak-to-peak

Figure 5.4.8 Tape Channel 7 Face side frame vertical displacement in mils peak-to-peak

In order to define the frequency content of the recorded sound and vibration outputs, a real time spectrum analyzer was used to produce frequency versus amplitude plots for selected test spans. Two operating modes of the Nicolet Scientific UA-500 analyzer were selected: Ensemble Averaged response for a statistical analysis of levels over a discrete time period, and Peak mode where the greatest level reached in any specific frequency bin during a selected time window is held. Each analysis technique has its specific advantages. The Time Averaged response is a realistic analysis of mean vibration levels which has a chance of being representative of "normal" operation. It sums each spectral component over 8, 16, 64, or any selected number of independent time increments and then divides by the time span to produce an arithmetic average of each frequency component.

In the Peak mode, the highest level attained during the analysis period, again selectable, is retained and displayed. If a significant short term response occurs, it will push the component levels to a high indicated spectral level, and all subsequent lower responses will have no influence. One hazard with

this technique is that several different inputs will give high responses in different frequency bins which might be interpreted as having been part of a single input. However, if the peak response ever attained is the desired level, this is a reasonable measure.

Detailed spectrum analysis plots were made for a section of tape data which represents normal full cut operation for this installation. At a point ten minutes into Tape #169, the first of the tapes, the machine was making a full cut at a nominal 10 feet per minute while moving to the left. Several minutes of continuous operation allowed both Time Averaged and Peak Averaged spectrum plots to be made. The frequency components and levels are typical, although the reduced tramming rate may keep the maximum amplitudes to somewhat less than what might be expected under maximum rate mining. The test plots included are:

Figures 5.4.9 thru 5.4.20 Frequency versus Amplitude for Recorded
Acceleration and Sound Test Data

Figures 5.4.21 thru 5.4.23 Frequency versus Amplitude for Double
Integrated Acceleration Data

Review of these test data provides some insight into the type of responses that chassis mounted transducers and electronics will experience during normal coal mining activities. Several observations can be made which will assist in making use of this information.

1. Accelerations recorded for ranging arm (drum) accelerometers (B&K 4344 units) are quite moderate with peak responses occurring during what seemed to be difficult cutting; the voice commentary at the maximum level of 4.3 G's peak for the left-hand drum was that the machine was jumping and that a bit fractured and was seen falling clear of the drum (end of tape 170). It should be noted that the Direct record channel does not respond linearly below 100 Hz so no low frequency high amplitude responses are recorded.

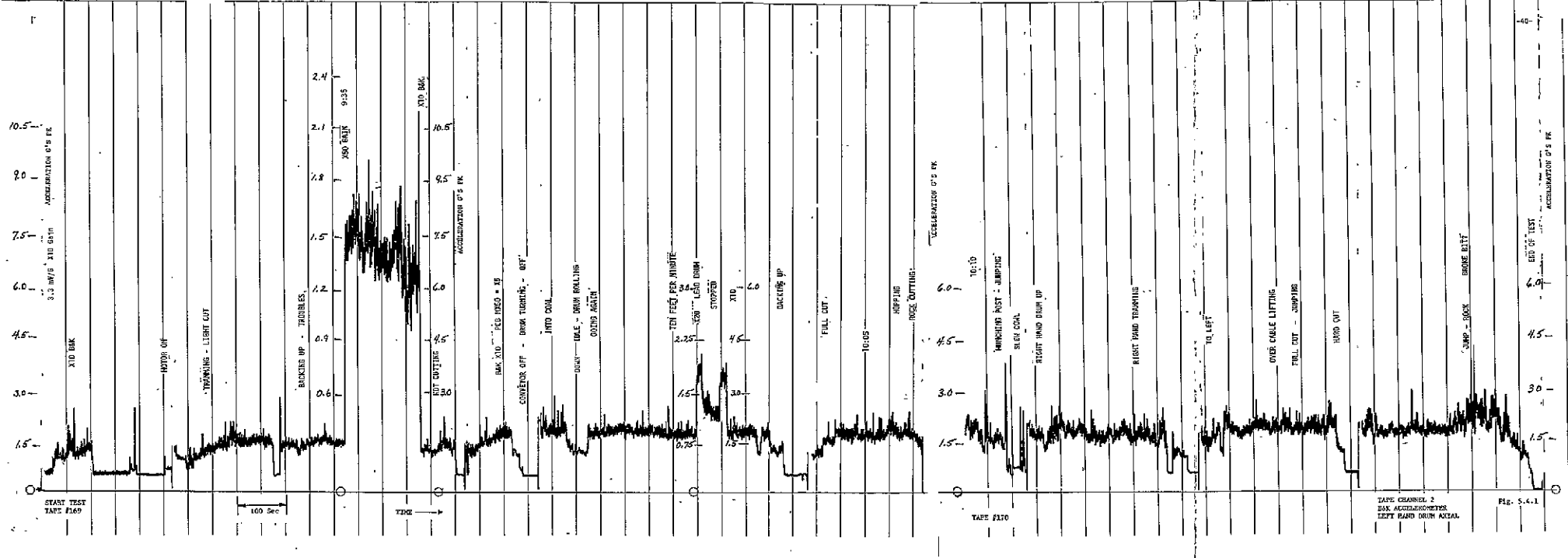

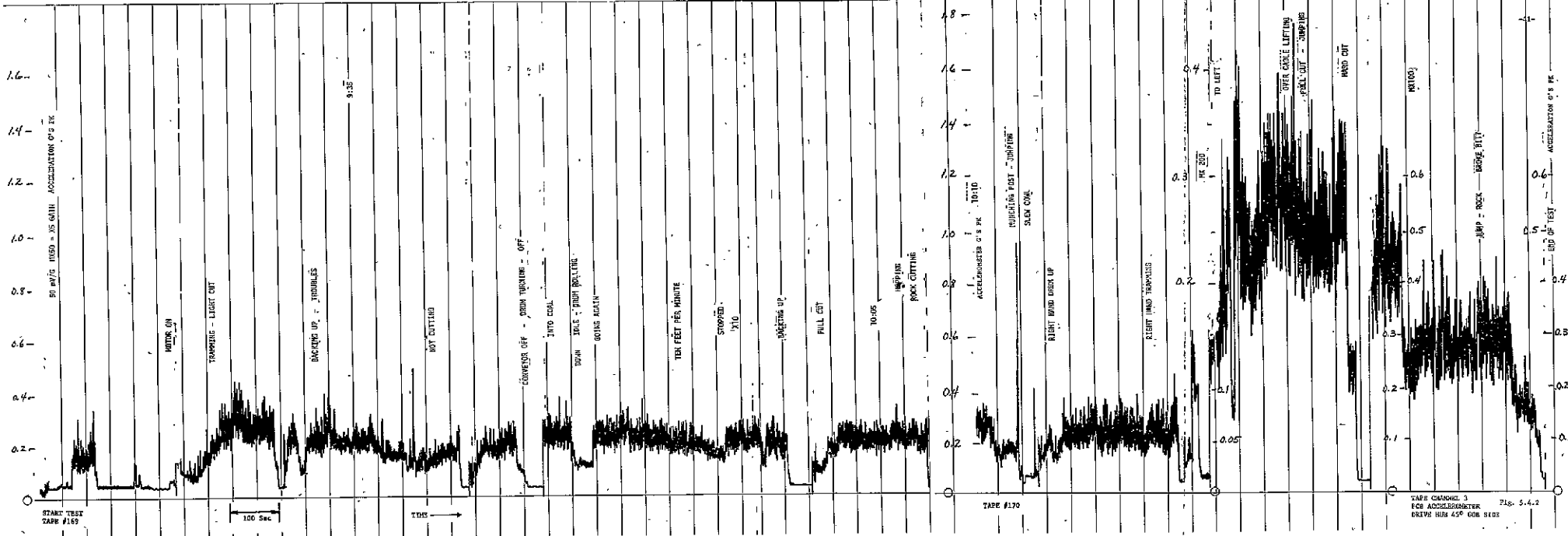

RECORD FRAME

RECORD FRAME 2

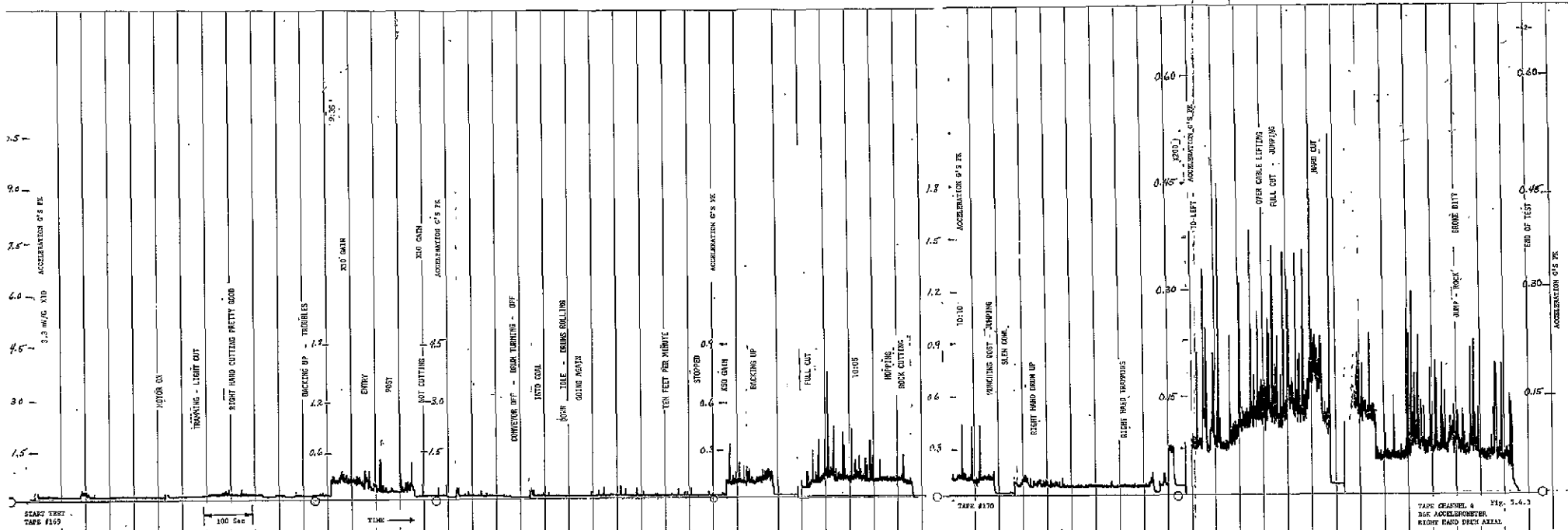

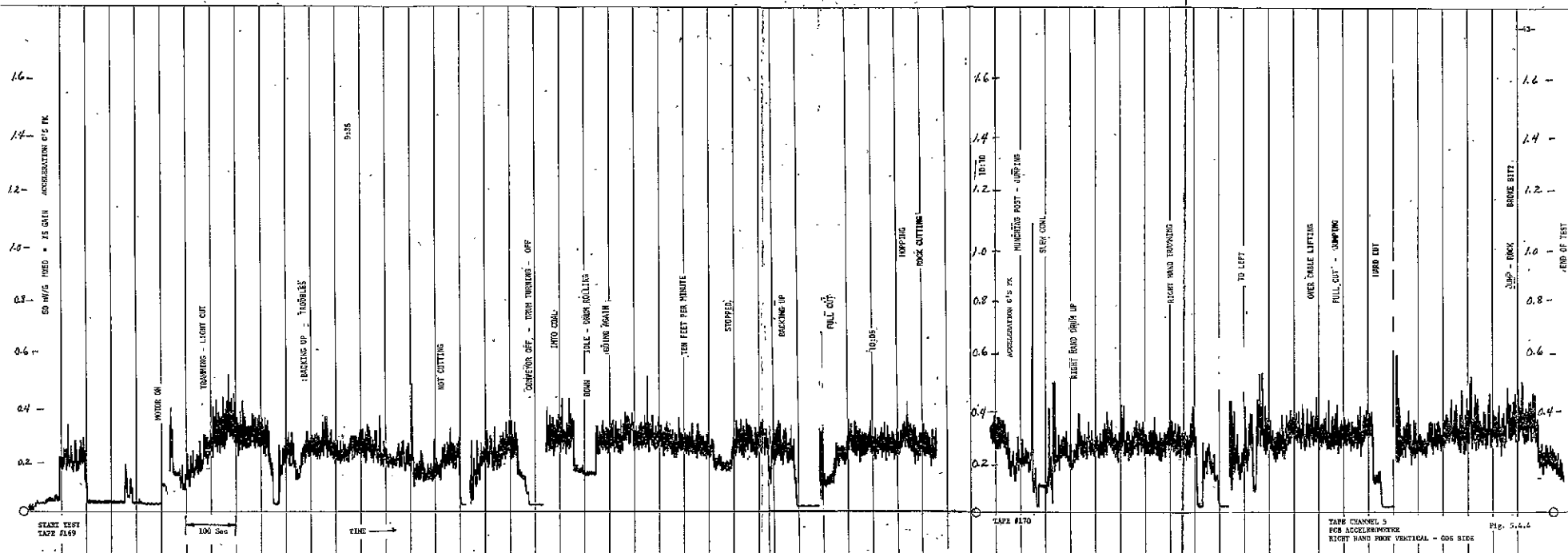
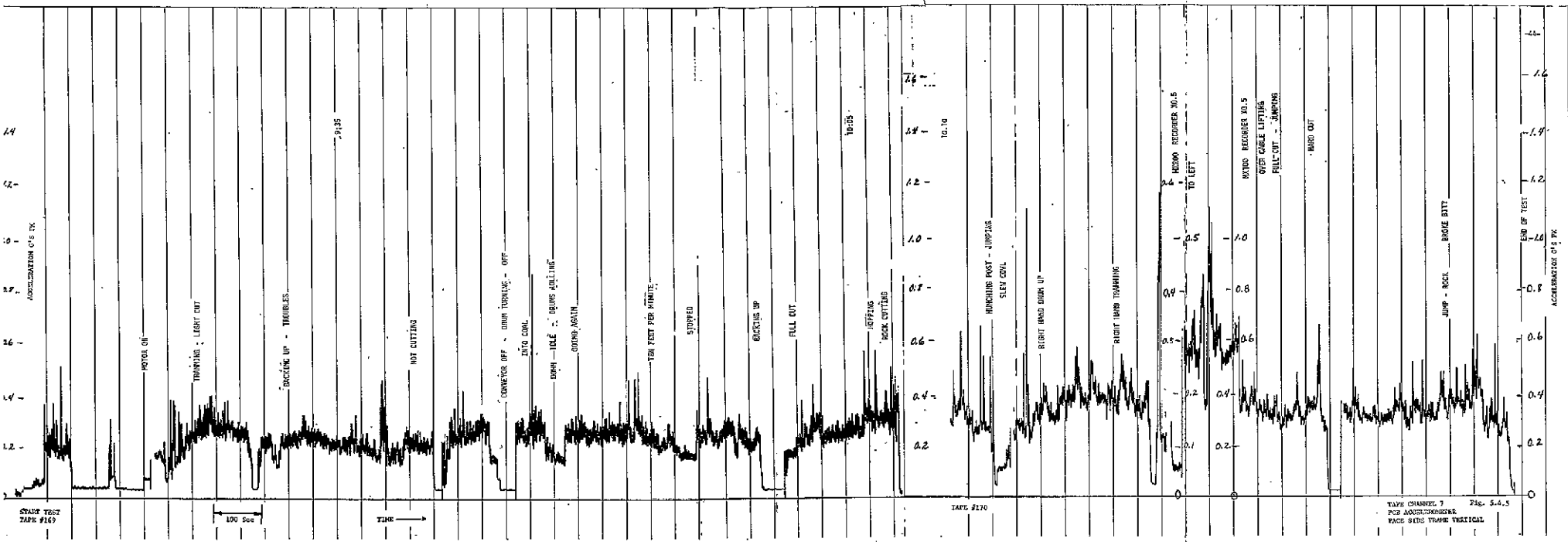

Fig. 5.4.4

ROCKING PLANT

2



START TEST MARK #169

100 Sec

TIME

MARK #170

TAPE CHANNEL 7 FOR ACCELEROMETER FACE SIDE TRAMP VERTICAL

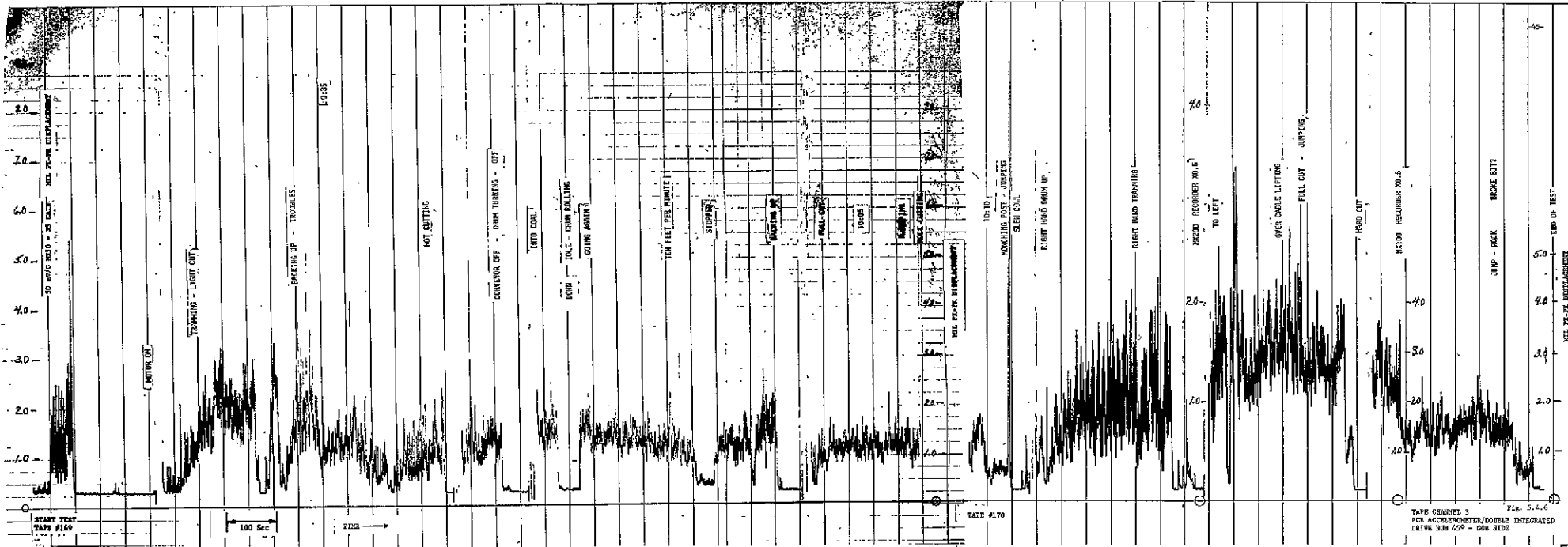

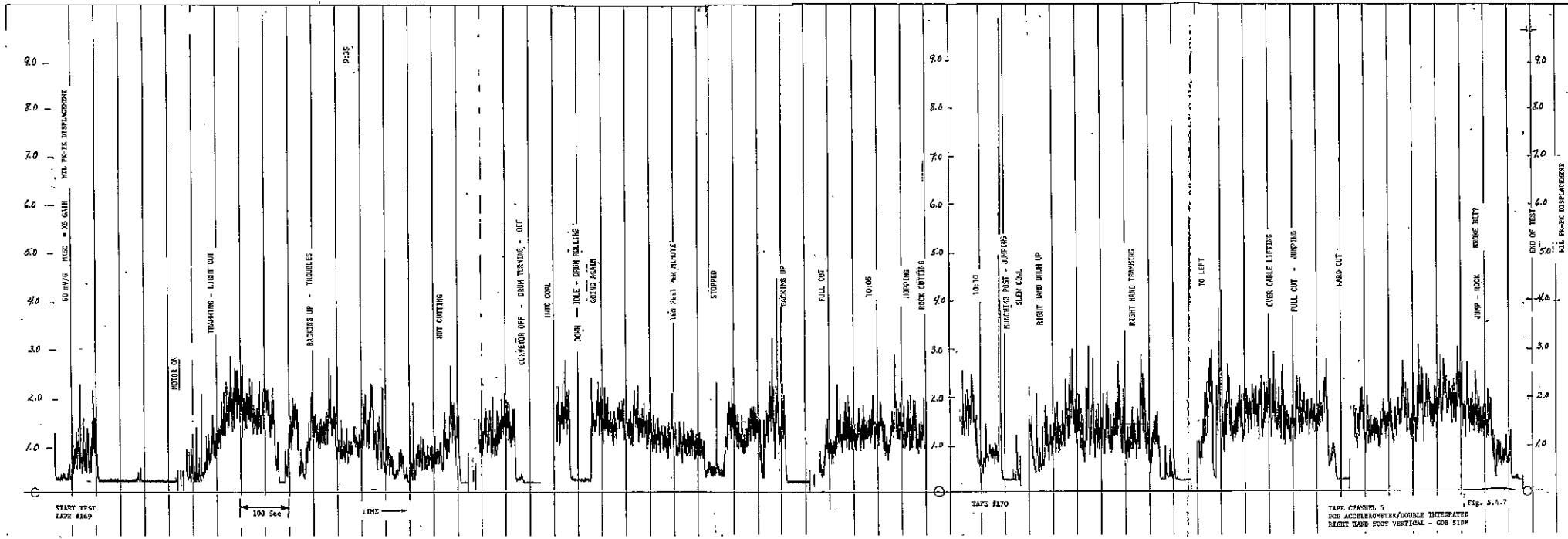

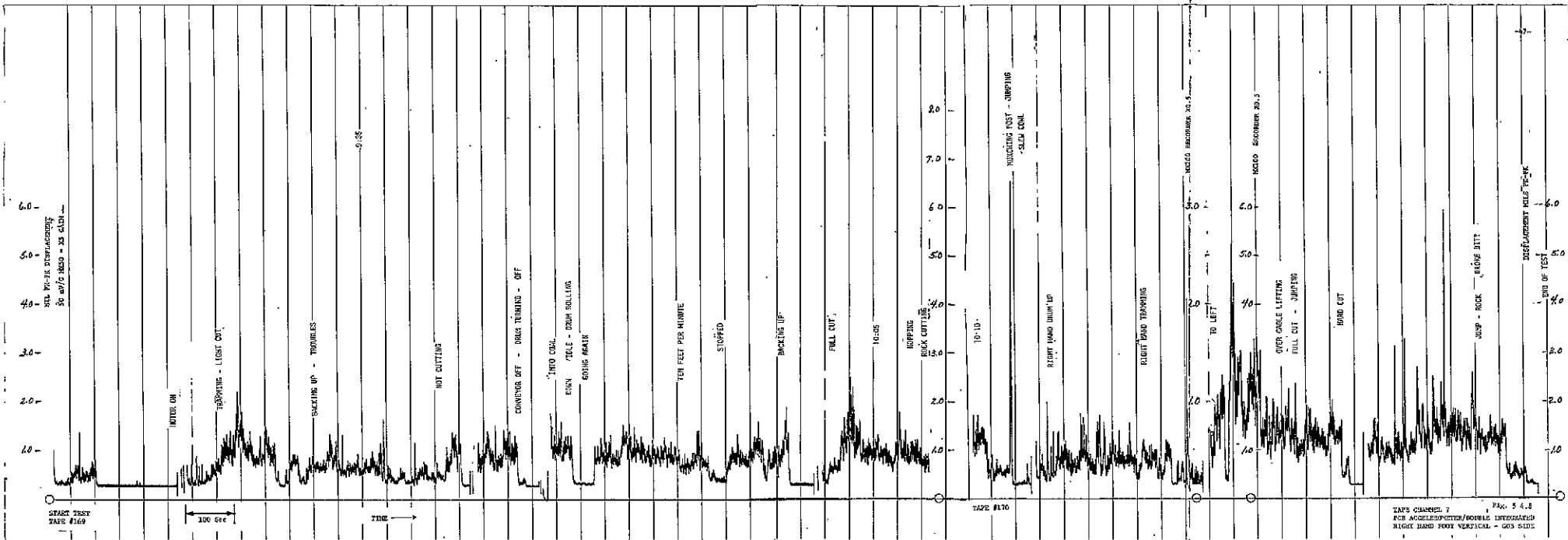

TAPE № 169 LOCATION 9:35 DATE 7/22/77 BY RFB
 TRANSDUCER PCB FREQ. RANGE 0-1000 RECORDER GAIN 0.5
 TAPE GAIN _____ INPUT RANGE 0.1 X-UNITS _____
 INPUT GAIN _____ OUTPUT GAIN X10 ANALYSIS _____
 TAPE CH. 1 TIME AV. 16
 TEST COND. _____

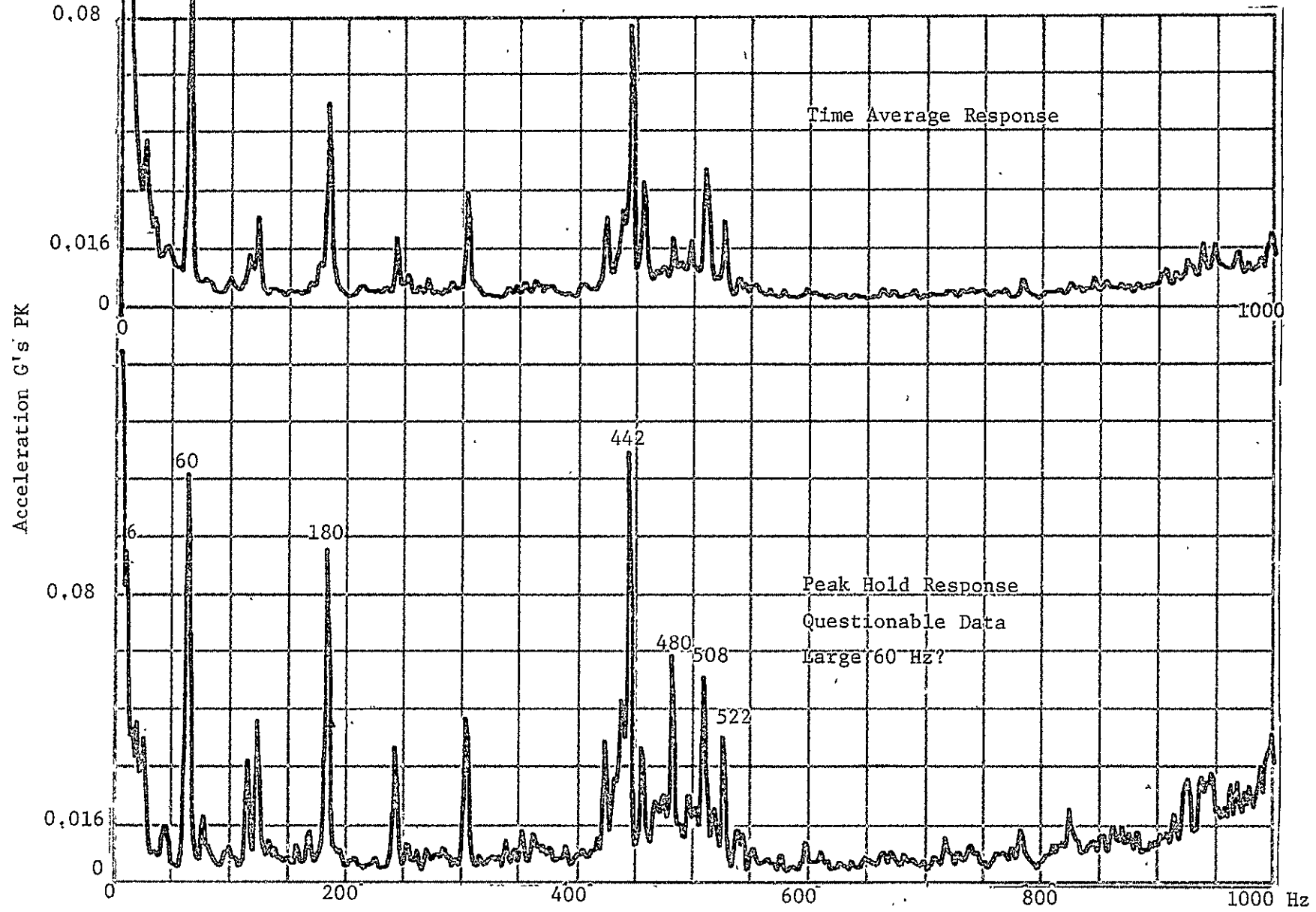

Tape Channel 1 Accelerometer Output Spectrum Analysis Normal Cut Moving Left

Figure 5.4.9

TAPE No. 102 LOCATION 9.150 DATE 1/22/77 BY _____
 TRANSDUCER PCB FREQ. RANGE 0-5000 RECORDER GAIN 1.0
 TAPE GAIN _____ INPUT RANGE 0.1 X-UNITS _____
 INPUT GAIN _____ OUTPUT GAIN X10 ANALYSIS _____
 TAPE CH. 1 TIME AV. 32 _____
 TEST COND. _____

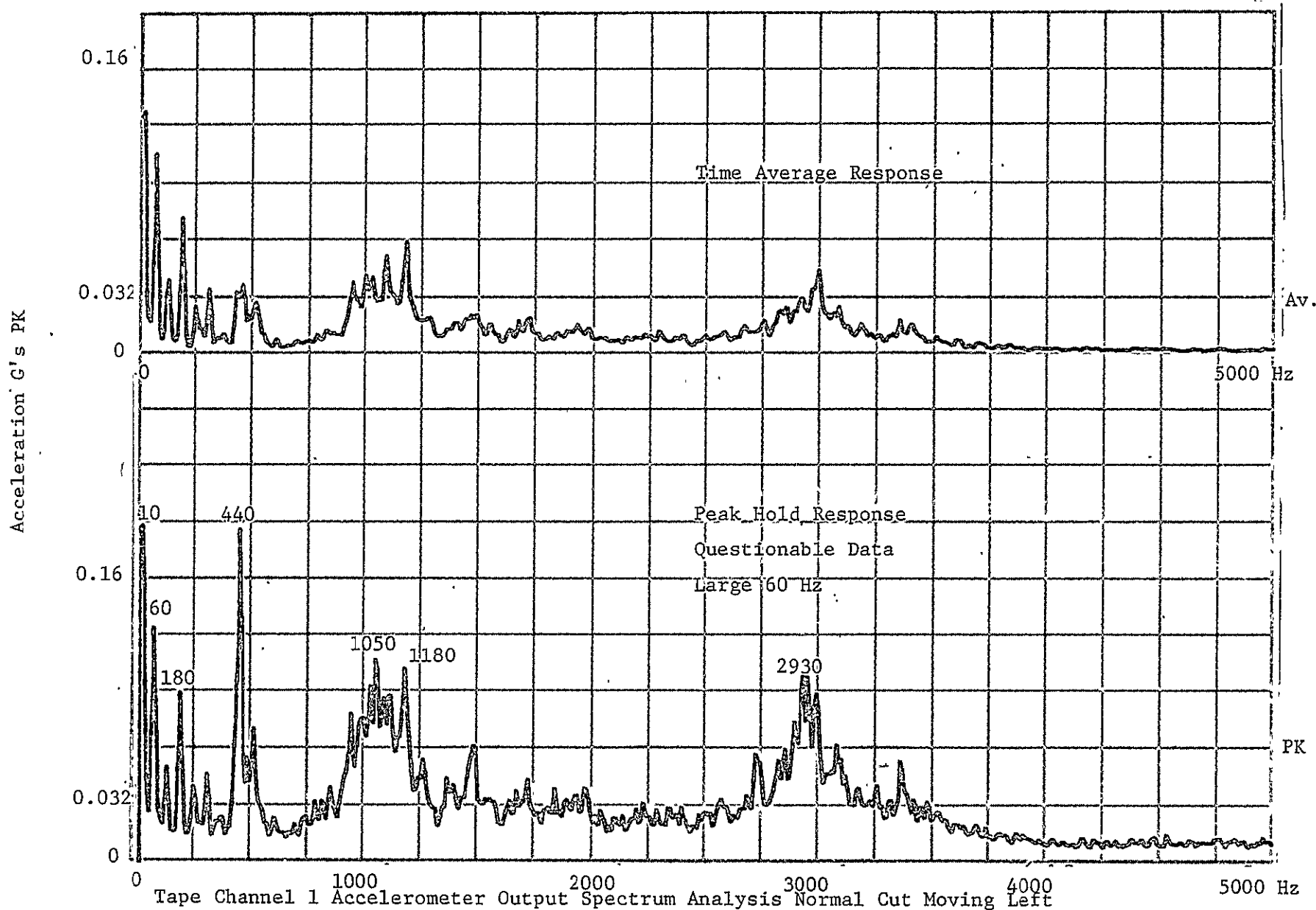
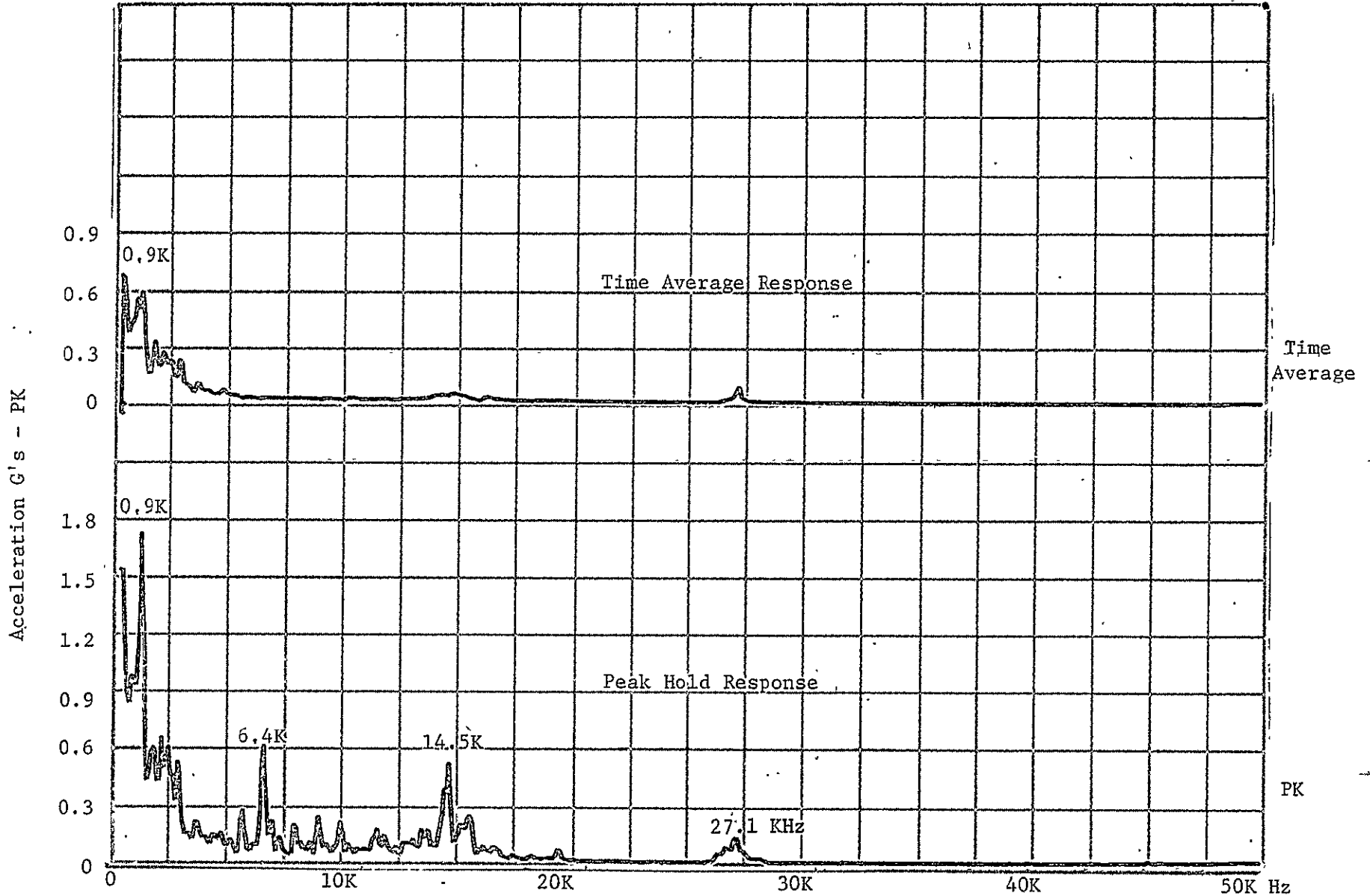

Figure 5.4.10

TAPE No. 169	LOCATION	DATE 7/22/77	BY REB
TRANSDUCER B&K 3.3 mv/G	FREQ. RANGE 0-50K	RECORDER GAIN 0.5	
TAPE GAIN X50	INPUT RANGE 1.0	X-UNITS	
INPUT GAIN	OUTPUT GAIN X1	ANALYSIS	
TAPE CH. 2	TIME AV. 64		
TEST COND.			



Tape Channel 2 Accelerometer Output Spectrum Analysis Normal Cut Moving Left

Figure 5.4.11

TAPE No. 102 LOCATION 332 DATE 11/22/77 BY KFB
 TRANSDUCER PCB FREQ. RANGE 0-1000 RECORDER GAIN 0.5
 TAPE GAIN MX50 = X5 INPUT RANGE 0.32 X-UNITS _____
 INPUT GAIN _____ OUTPUT GAIN X3.2 ANALYSIS _____
 TAPE CH. 3 TIME AV. 16 _____
 TEST COND. After backing up _____

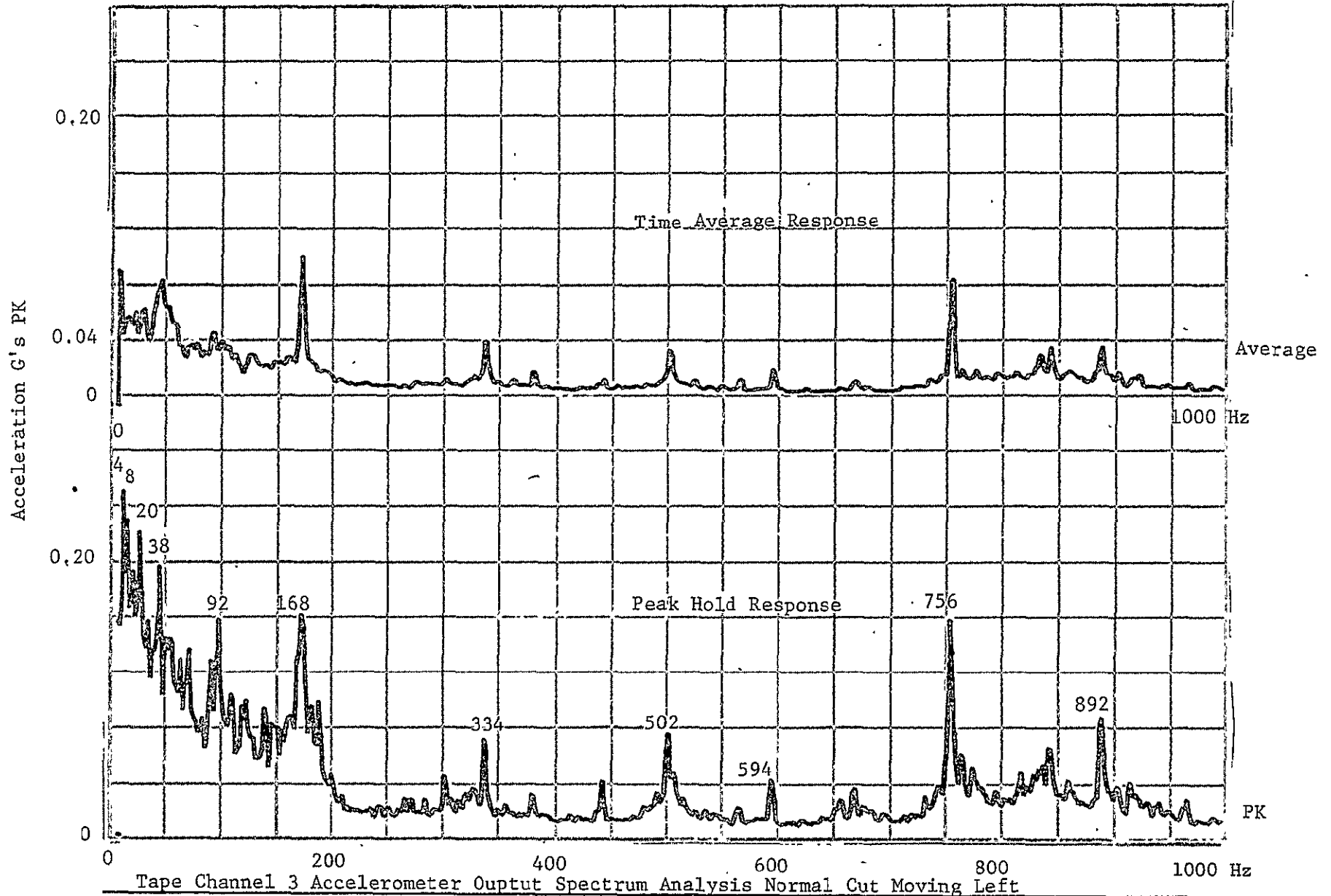

Tape Channel 3 Accelerometer Output Spectrum Analysis Normal Cut Moving Left

Figure 5.4.12

TAPE NO.	LOCATION	DATE	BY
TRANSDUCER PCB		FREQ. RANGE 0-5000	RECORDER GAIN 1.0
TAPE GAIN		INPUT RANGE 0.32	X-UNITS
INPUT GAIN		OUTPUT GAIN X3.2	ANALYSIS
TAPE CH. 3		TIME AV.	
TEST COND.			

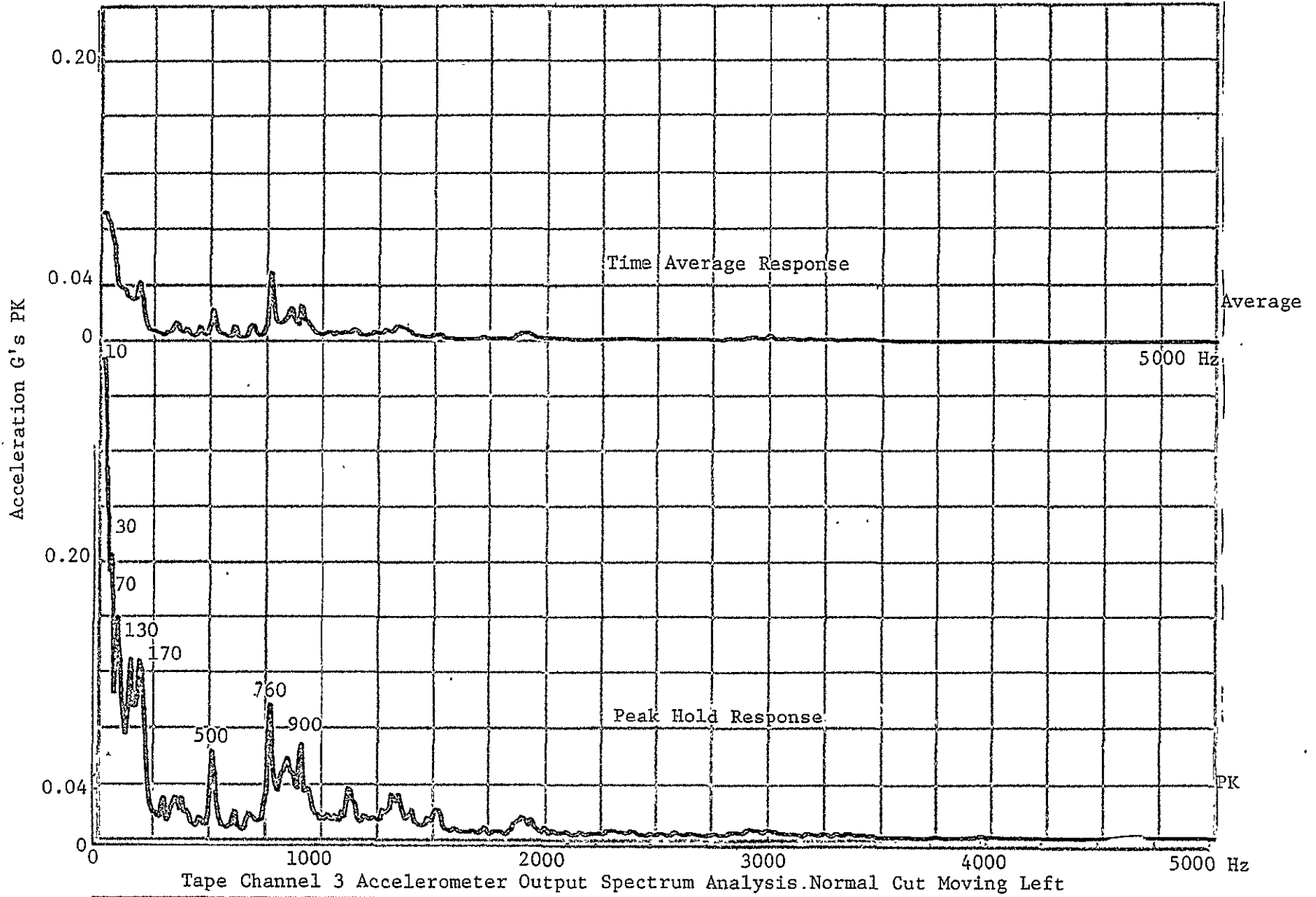

Tape Channel 3 Accelerometer Output Spectrum Analysis. Normal Cut Moving Left

Figure 5.4.13

TAPE NO. <u>107</u>	LOCATION _____	DATE <u>11-21-71</u>	BY <u>KLD</u>
TRANSDUCER <u>B&K</u>	FREQ. RANGE <u>0-50K</u>	RECORDER GAIN <u>1.0</u>	
TAPE GAIN _____	INPUT RANGE <u>0.1</u>	X-UNITS _____	
INPUT GAIN <u>X50</u>	OUTPUT GAIN <u>X10</u>	ANALYSIS _____	
TAPE CH. <u>4</u>	TIME AV. <u>64</u>		
TEST COND. _____			

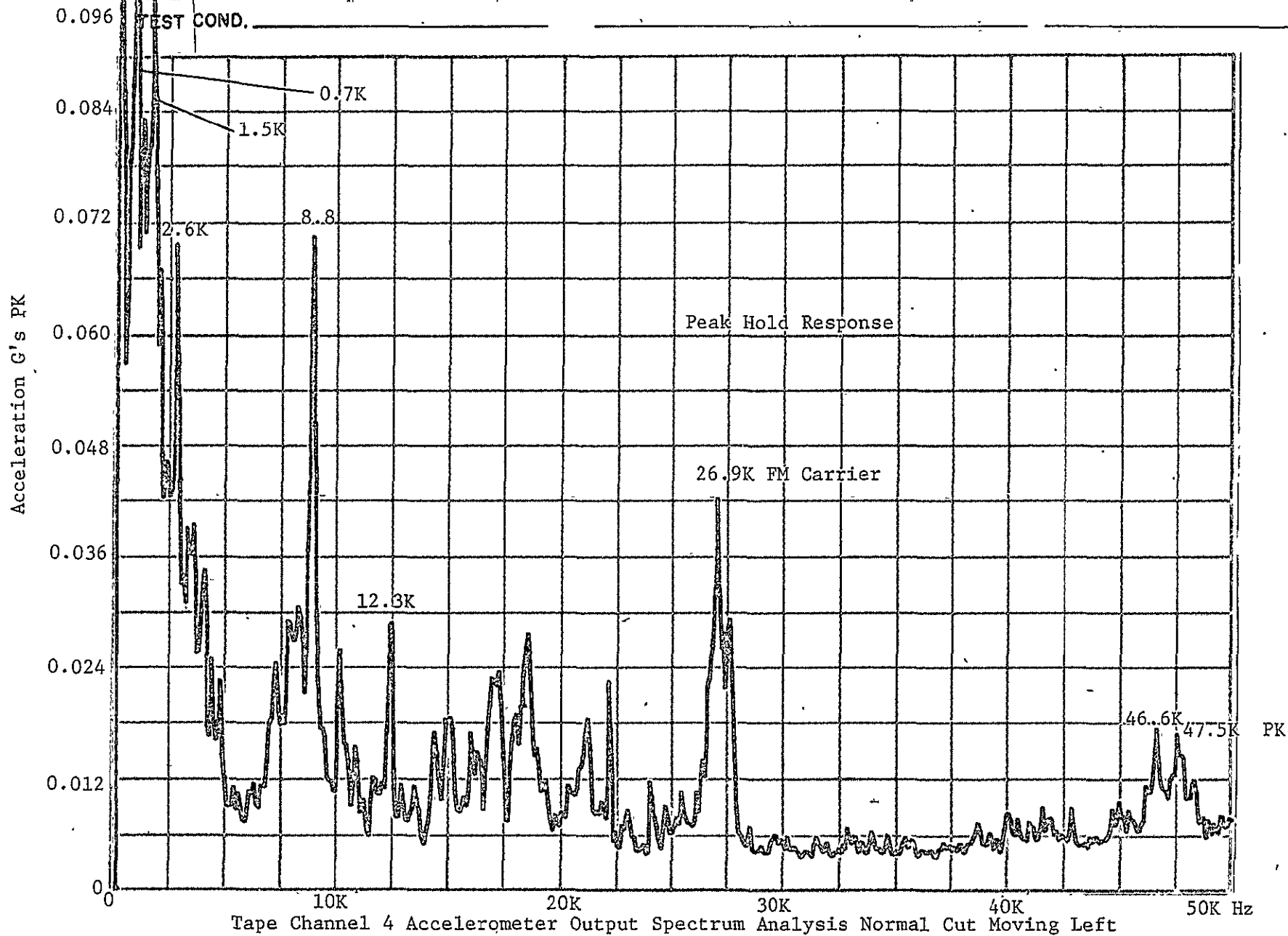

Tape Channel 4 Accelerometer Output Spectrum Analysis Normal Cut Moving Left

Figure 5.4.14

TAPE NO. <u>1169</u>	LOCATION _____	DATE <u>1/22/77</u>	BY <u>MLD</u>
TRANSDUCER <u>B&K</u>	FREQ. RANGE <u>0-50K</u>	RECORDER GAIN <u>1.0</u>	
TAPE GAIN <u>X50</u>	INPUT RANGE <u>0.1</u>	X-UNITS _____	
INPUT GAIN _____	OUTPUT GAIN <u>X10</u>	ANALYSIS _____	
TAPE CH. <u>4</u>	TIME AV. <u>64</u>		
TEST COND. _____			

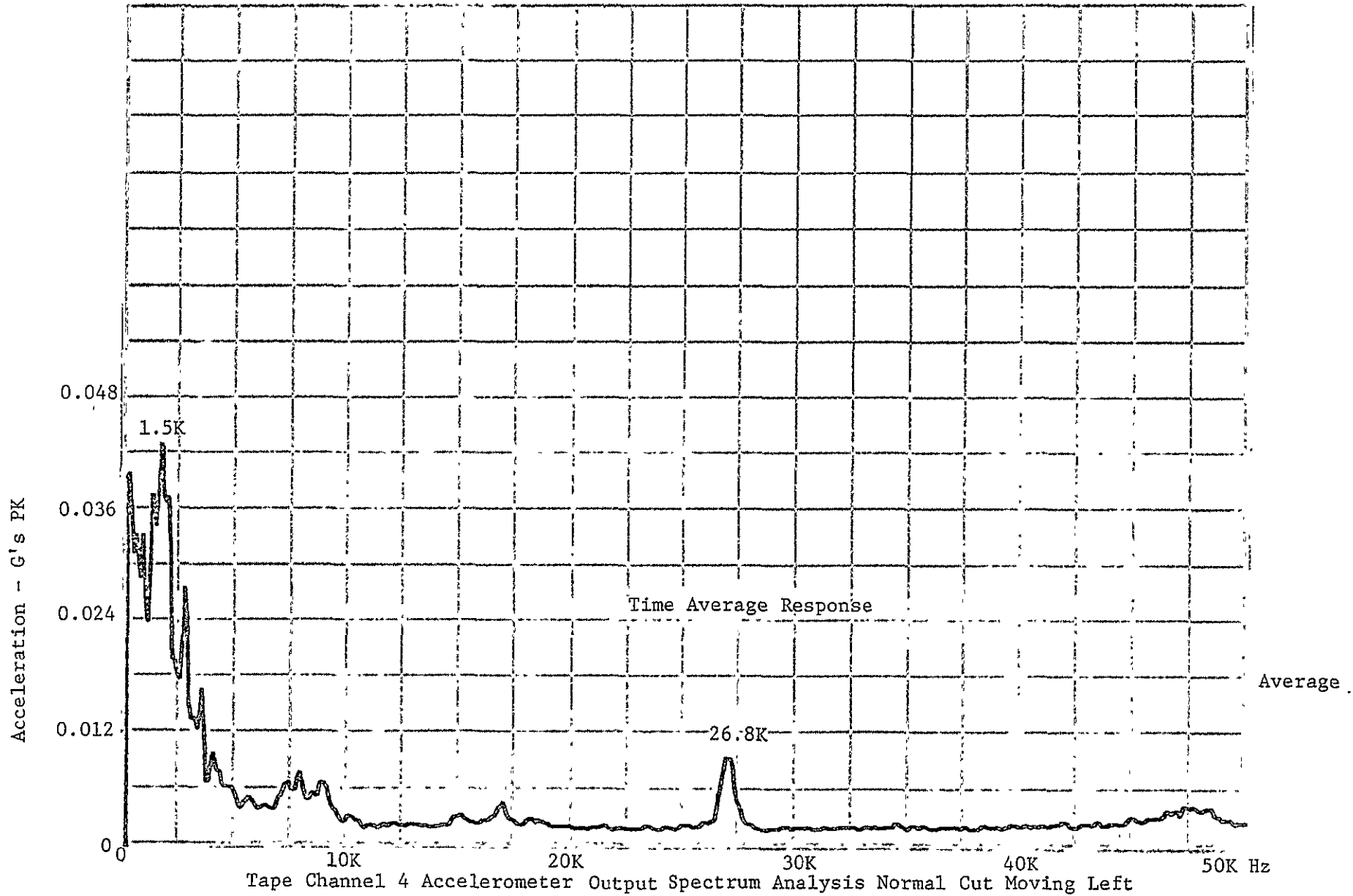

Tape Channel 4 Accelerometer Output Spectrum Analysis Normal Cut Moving Left

Figure 5.4.15

TAPE NR. 169 LOCATION 9:35 DATE 1/22/77 BY RFB
 TRANSDUCER PCB FREQ. RANGE 0-1000 RECORDER GAIN 0.5
 TAPE GAIN MX50 INPUT RANGE 0.32 X-UNITS _____
 INPUT GAIN _____ OUTPUT GAIN X3.2 ANALYSIS _____
 TAPE CH. 5 TIME AV. 16 _____
 TEST COND. _____

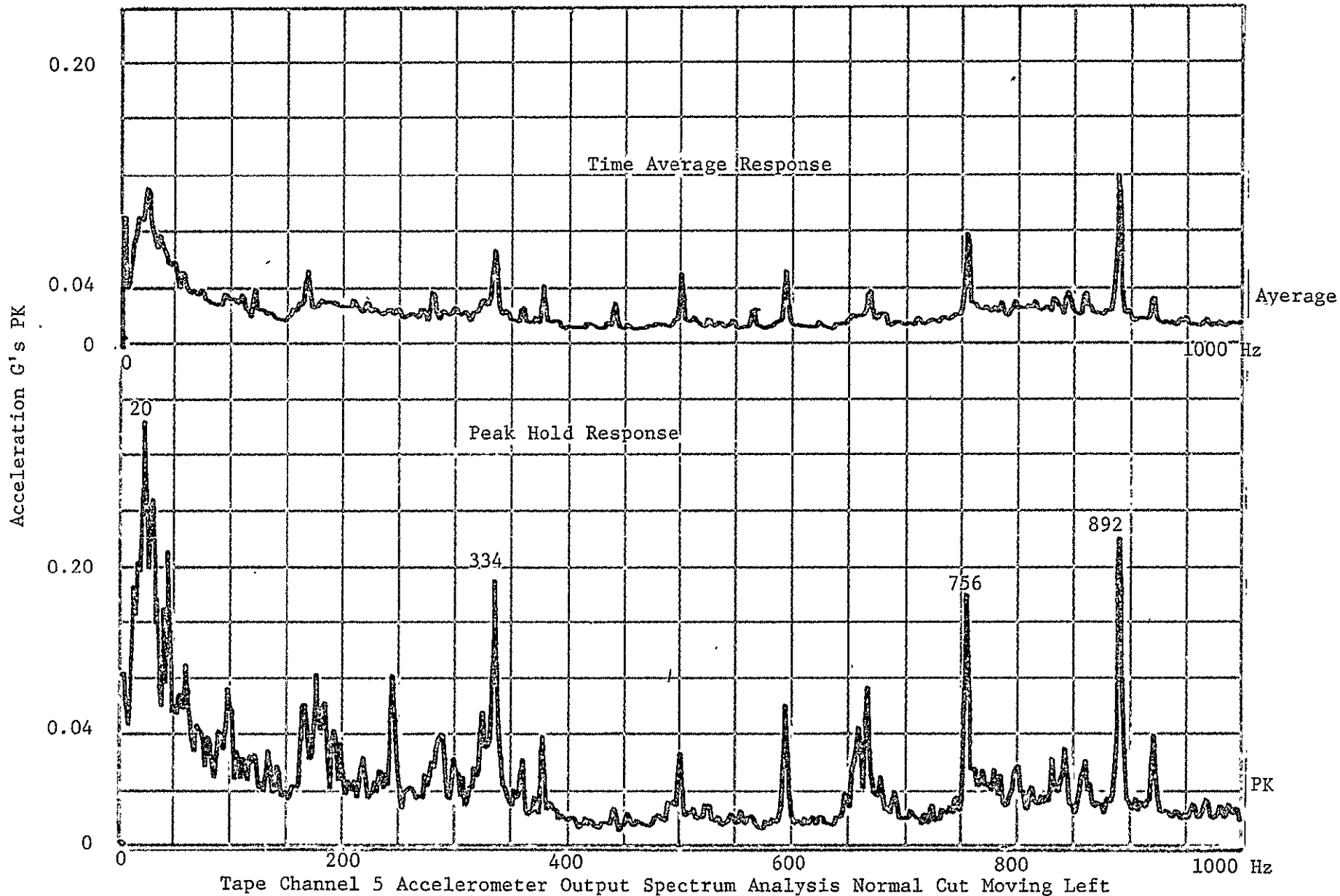
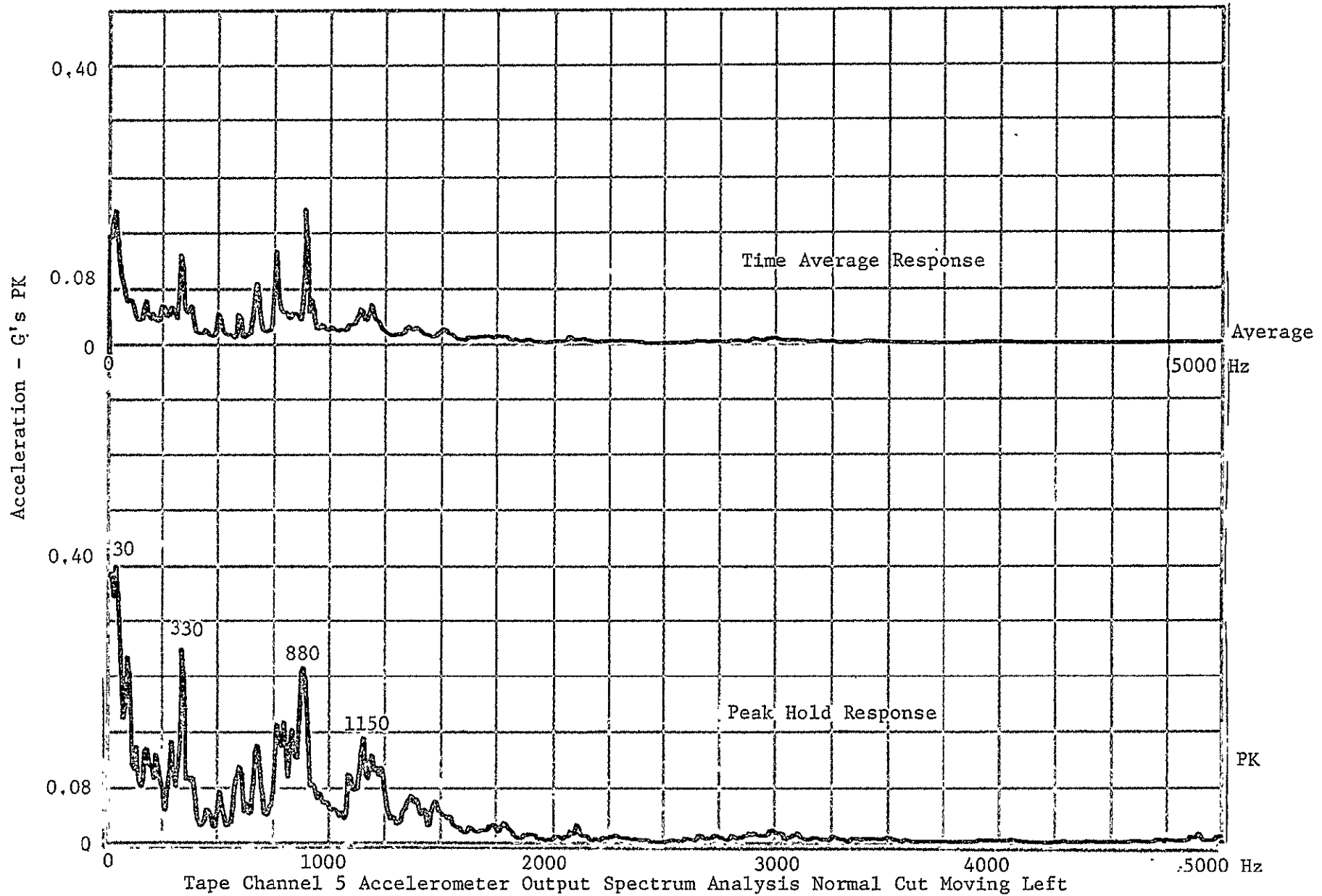

Figure 5.4.16

TAPE NO. _____	LOCATION 2107	DATE 1/25/77	TIME 11:00
TRANSDUCER PCB	FREQ. RANGE 0-5000	RECORDER GAIN 1.0	
TAPE GAIN _____	INPUT RANGE 0.32	X-UNITS _____	
INPUT GAIN _____	OUTPUT GAIN X3.2	ANALYSIS _____	
TAPE CH. 5	TIME AV. 32		
TEST COND. _____			



Tape Channel 5 Accelerometer Output Spectrum Analysis Normal Cut Moving Left

Figure 5.4.17

TAPE NO. 102 LOCATION DATE 1/22/77 BY RFB
 TRANSDUCER SLM FREQ. RANGE 0-20K RECORDER GAIN 1.0
 TAPE GAIN 130dB set INPUT RANGE 0.1 X-UNITS
 INPUT GAIN OUTPUT GAIN X10 ANALYSIS
 TAPE CH. 6 TIME AV. 16
 TEST COND.

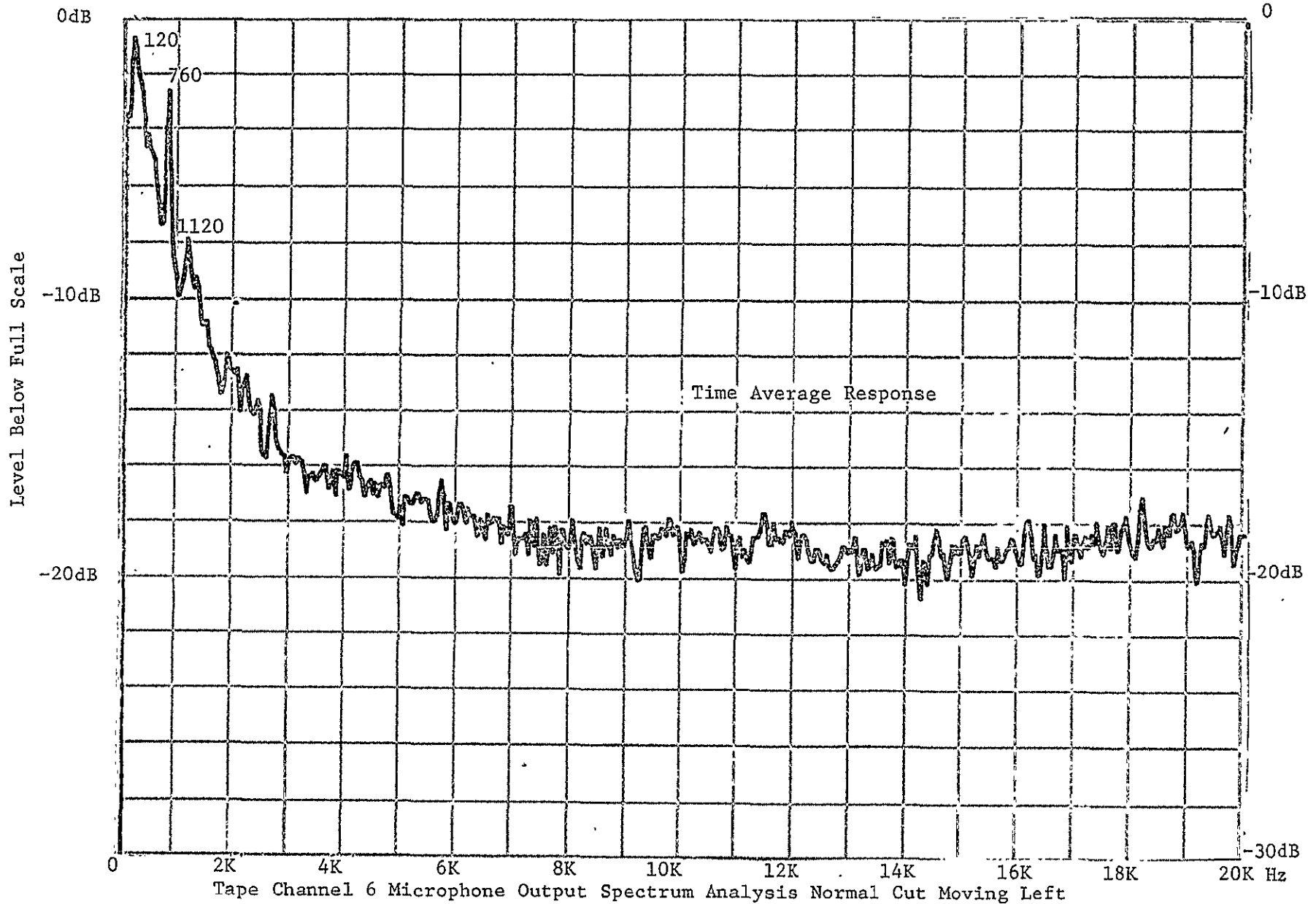
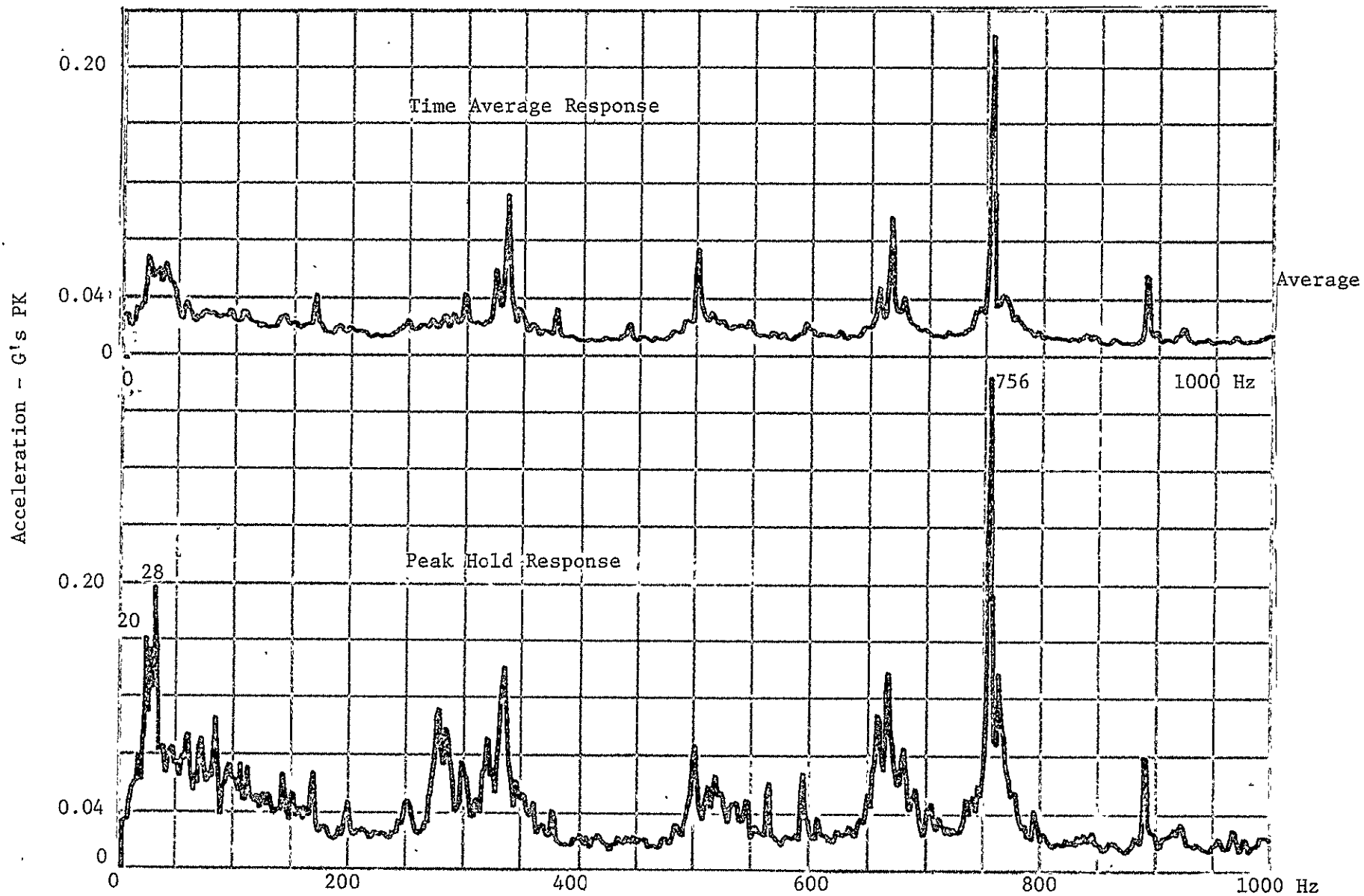

Figure 5.4.18

TRANSUCER	PCB	FREQ. RANGE	0-1000	RECORDER GAIN	0.5
TAPE GAIN	MX50	INPUT RANGE	0.1	X-UNITS	
INPUT GAIN		OUTPUT GAIN	X1	ANALYSIS	
TAPE CH.	7	TIME AV.	16		
TEST COND.					



Tape Channel 7 Accelerometer Output Spectrum Analysis Normal Cut Moving Left

Figure 5.4.19

TAPE NO. 109 LOCATION 9:55 DATE 1/22/77 BY RFB
 TRANSDUCER PCB FREQ. RANGE 0 - 5000 RECORDER GAIN 1.0
 TAPE GAIN _____ INPUT RANGE 0.32 X-UNITS _____
 INPUT GAIN _____ OUTPUT GAIN X3.2 ANALYSIS _____
 TAPE CH. 7 TIME AV. 32 _____
 TEST COND. _____

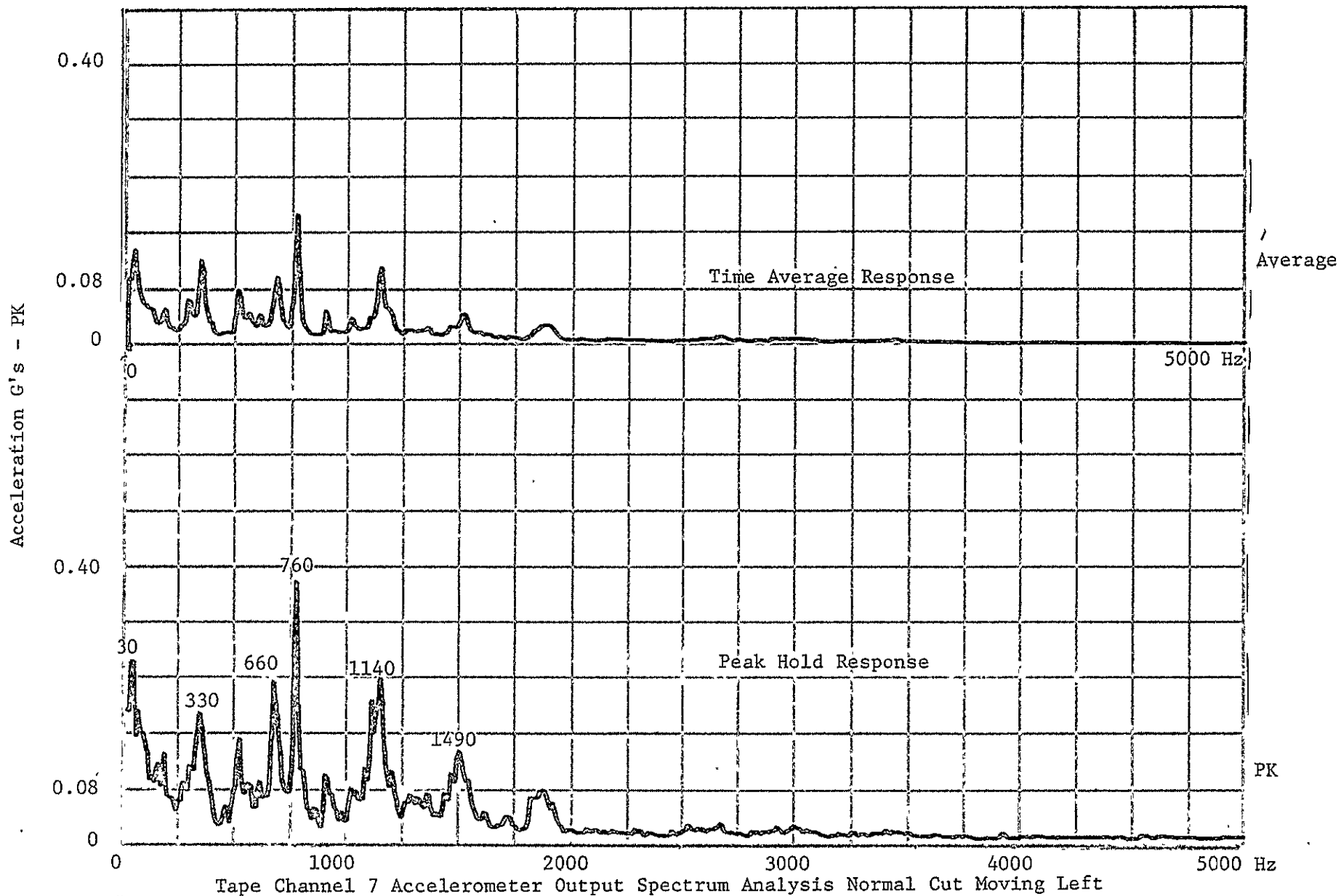

Figure 5.4.20

TAPE №. _____ LOCATION _____ DATE 11/22/11 BY KED
 TRANSDUCER PCB/Double Integrated FREQ. RANGE 0-100 (200) RECORDER GAIN 0.5
 TAPE GAIN _____ INPUT RANGE 0.1 X-UNITS _____
 INPUT GAIN MX20 OUTPUT GAIN X1 ANALYSIS _____
 TAPE CH. 3 TIME AV. 4 _____
 TEST COND. _____

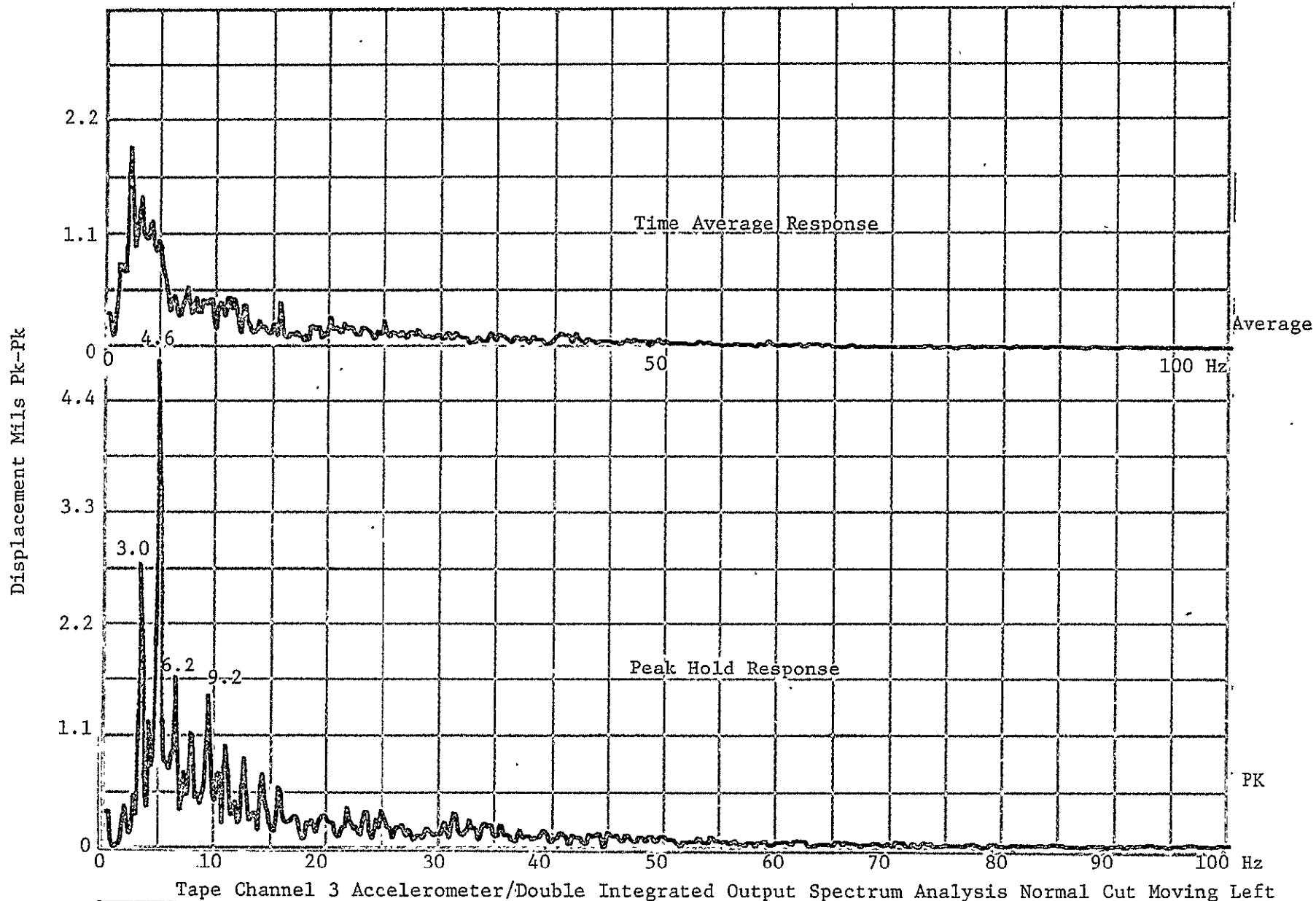

Figure 5.4.21

TAPE NO. 107 LOCATION _____ DATE 1/22/77 BY RLD
 TRANSDUCER PCB FREQ. RANGE 0-100 (200) RECORDER GAIN 0.5
 TAPE GAIN _____ INPUT RANGE 0.1 X-UNITS _____
 INPUT GAIN MX20 & then Dbl Int. OUTPUT GAIN X1 ANALYSIS _____
 TAPE CH. 5 TIME AV. 4 _____
 TEST COND. _____

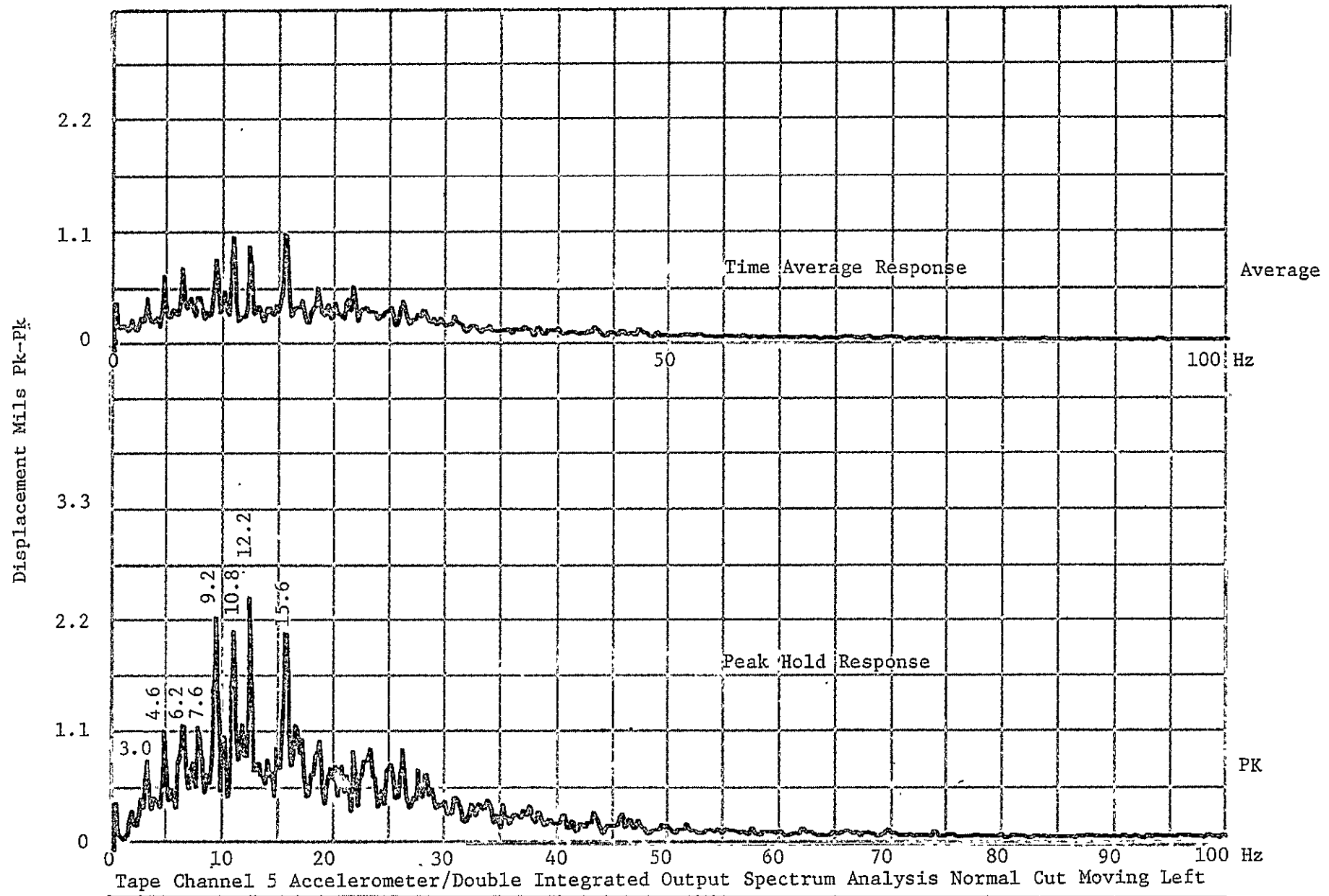

Figure 5.4.22

TAPE No. 109 LOCATION _____ DATE 7/22/77 BY RFB
 TRANSDUCER PCB FREQ. RANGE 0-100 (200) RECORDER GAIN 0.5%
 TAPE GAIN _____ INPUT RANGE 0.1 X-UNITS _____
 INPUT GAIN MX20 & then Db1 Integrated OUTPUT GAIN X1 ANALYSIS _____
 TAPE CH. 7 TIME AV. 4 _____
 TEST COND. _____

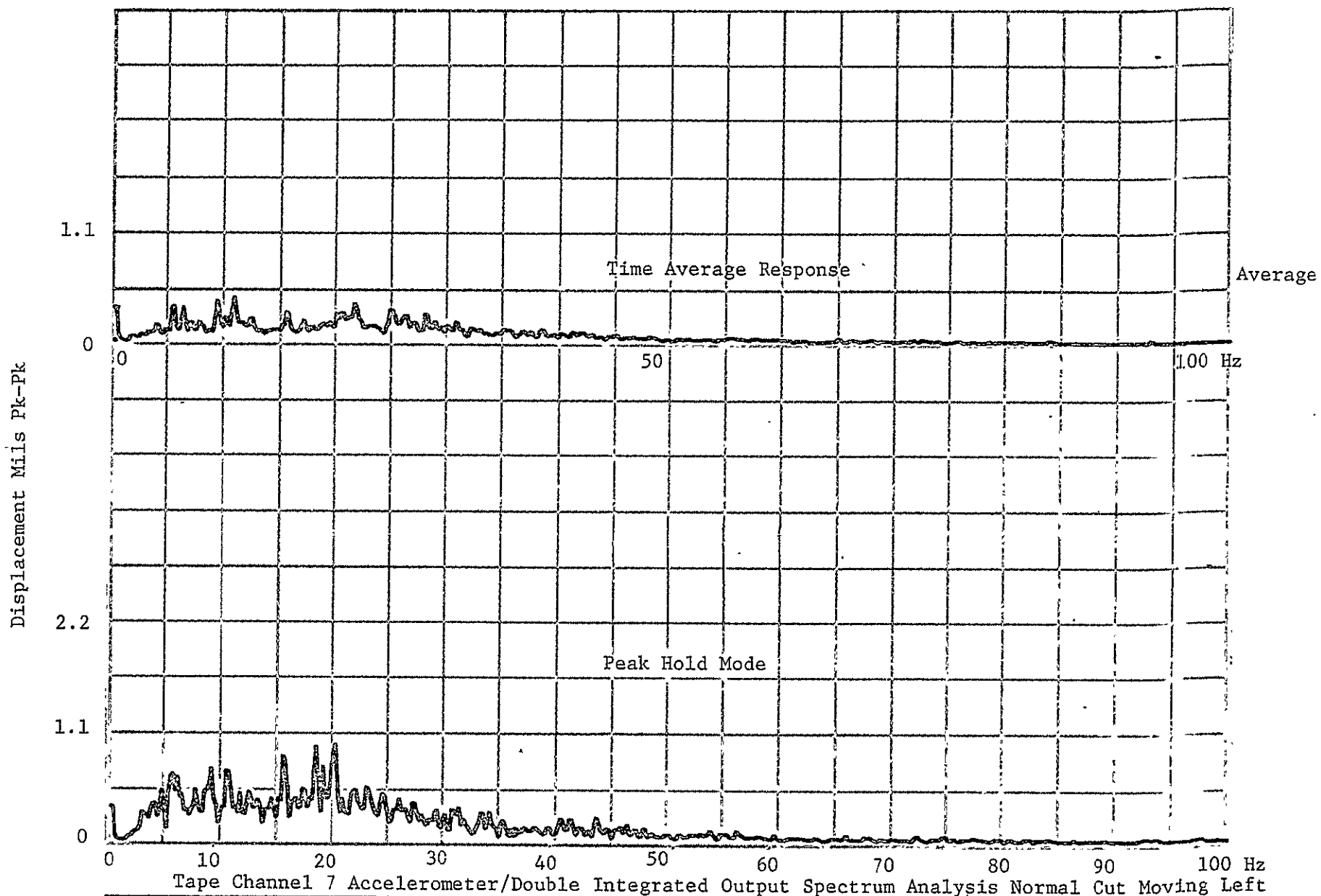

Figure 5.4.23

The trailing drum generally has response levels $1/4$ to $1/10$ as great as the leading drum, about in proportion to the work being done by each.

2. Maximum recorded mining machine chassis vibration occurs at about the center of the gob side frame, our Location 3. Based upon integrated acceleration response, normal levels of vibration are in the range of 2-3 mils peak-to-peak, but a review of the acceleration peak hold spectrum analysis plot, Figure 5.4.12, shows a major frequency response at 8 Hz of 0.26 G's peak which, when converted to displacement, is equal to 80 mils peak-to-peak displacement. The time averaged spectrum analysis level for the same operating region shows levels of 0.05 G's, equivalent to 15 mils peak-to-peak displacement at 8 Hz. Apparently the double integrator output is not responding properly at very low frequencies as the Figure 5.4.6 displacements do not reach that level.
3. The face side chassis accelerometer Location 7 seems relatively lower in amplitude response with little of the low frequency vibration. It is assumed that the face side guide shoes stay in contact with the face conveyor rails with that as the pivot point for drum input force variations: a down force on the lead drum causes the gob side of the chassis to rise. Higher frequency components, however, are up somewhat in level with response at 760 Hz of a character which might cause loosening of bolts. Its source is unknown.
4. The gob side chassis sensor mounted at Location 5 was assumed to be near a guide shoe when it was selected, but because of machine modifications there was no face conveyor contact in that region as only one shoe remained on that side right under the rack drive sprocket. The reduced amplitude low frequency response (below 10 Hz), as compared to sensor Location 3, indicates that the major

responses are forced by the harder working drum and that chassis flexibility reduces responses away from the point of major load application. If this installation were cutting in both directions the sensor would have had increased response.

One possible use of these test data would be the definition of platform vibration characteristics for qualification of mining machine transducers and conditioning equipment which are being developed for coal interface detection. It is expected that this is as typical of normal mining as can be obtained, at least in the full cut conditions while moving left. Trimming speeds are fairly low at 10 feet per minute, but the quantity of rock being cut increases the cutting shock over what would be expected in coal-only mining. A recommended typical test level for equipment qualification would be as follows, assuming a sine sweep to a shaker system:

3 Hz to 10 Hz = 0.100 inch peak-peak amplitude
10 Hz to 30 Hz = 0.020 inch peak-peak amplitude
30 Hz to 500 Hz = 1G peak acceleration
500 Hz to 3000 Hz = 3G peak acceleration

A resonant search of the tested device should be conducted with a minimum of ten minutes spent at each identified natural frequency. Natural frequencies of the Joy machine structure occur at 8 Hz, 20 Hz, 38 Hz, 90 Hz, 168 Hz, 334 Hz, 502 Hz, 756 Hz, and 892 Hz so components to be mounted on this machine should not have resonances present within 5% of these frequencies.

6.0 SUMMARY

This program has resulted in the design, manufacture, and testing of a data gathering system usable in the severe environment of an operating coal mine. The equipment package is available for a variety of test uses to provide previously unavailable measurement capability. The test data recorded in this program can be further analyzed to provide additional insight to mining machine dynamic performance.

APPENDIX I

DESIGN REPORT

WIRELESS DATA TRANSMISSION SYSTEM
FOR SENSITIZED PICK
COAL INTERFACE DETECTOR

On

Longwall Mining Machines

By

R. F. Burchill and W. D. Waldron

Under Contract No. NAS8-31668

Marshall Space Flight Center

SHAKER RESEARCH CORPORATION
Northway 10 Executive Park
Ballston Lake, N. Y. 12019

TABLE OF CONTENTS

	<u>Page</u>
I. INTRODUCTION _____	1
II. SENSITIZED PICK CID CONCEPT _____	4
III. MINE REVIEW AND MACHINE SELECTION _____	9
IV. TELEMETRY SYSTEM REQUIREMENTS _____	13
V. INSTRUMENTED PICK DESIGN _____	15
VI. ALTERNATE CONCEPTS _____	23
VII. RECOMMENDED EVALUATION PROGRAM _____	32
VIII. REFERENCES _____	34
APPENDIX I _____	35
APPENDIX II _____	38

LIST OF FIGURES

<u>Figure</u>		<u>Page</u>
1	Drum Position Vs Cutting Depth _____	5
2	Example of Typical Signals from Instrumented Pick _____	7
3	Instrumented Pick Block _____	16
4	Instrumented Pick Block and Transmitter Mounted on Joy Miner Drum _____	17
5	Telemetry Transmitter Assembly _____	19
6	Data Transmission System Sensitized Pick Detector _____	20
7	Shaker Research 4 Channel Telemetry System _____	22
8	Examples of Shadow Pick Arrangements _____	25
9	Cutting Depth Vs Drum Position (15° Lag Shadow Pick) _____	27
10	Cutting Depth Vs Drum Position (30° Lag Shadow Pick) _____	28
11	Surface Mount Telemetry Transmitter Assembly _____	30
12	Instrumented Pick Block and Surface Transmitter Mounted on Joy Miner Drum _____	31

I. INTRODUCTION

Increased national energy requirements along with more stringent health and safety regulations have provided the impetus to studies of ways to automate the underground mining of coal. Present continuous mining processes require that an operator be stationed near the coal cutting tool to guide the mining machine. Noise and dust levels often are excessive and force the use of personal protective equipment. The operator regularly has to adjust the cutting head to insure maximum coal recovery with minimum tool wear and foreign material contamination.

Where coal seams are reasonably thick and consistent, increasing use is being made of the longwall type of continuous miner with rotating drum cutting heads. This mining system has the mining machine traversing a 300 to 700 foot long face on an armored conveyor with a self-advancing ceiling support jack array which protects the mining machine and its operators from cave-in danger but lets the ceiling collapse behind the mining area as nearly all the coal is removed in a one-time-through operation. The drum cutters remove from 24 to 30 inches of coal from floor to ceiling on each horizontal pass across the coal seam face.

Single drum and two drum mining machines are used with the choice of type being dependent upon the consistency of coal seam thickness and the undulating character of the seam. For regular, uniform coal seams of from 39 inches to about 62 inches, a single drum machine taking a single full depth cut or alternately cutting ceiling and floor in two passes is a practical arrangement. The cutting drum can be mounted on a ranging arm to permit adjustment of the cut, or the complete machine can be lifted or lowered by jacking the unit on its conveyor skids to keep the cutting action within the coal seam.

Where the coal seam thickness exceeds six feet or varies significantly in thickness and pitch, the preferred mining machine has two cutting drums on ranging arms to permit complete control over ceiling and floor cutting planes. The leading drum usually is set to make the ceiling cut, and it often is required to remove up to 3/4ths of the height of the seam. The trailing drum

then does significantly less work and cleans up the remaining material. On the next cut in the opposite direction the drum positions are reversed so the former trailing drum becomes the lead. Because the head end and tail end entries are not wide enough to contain the complete mining machine, there often is a significant percentage of operating time spent in "sumping in" or gradually pushing the mining machine into the face while moving along the face conveyor track. The cutting drums can do a limited amount of end milling type cutting, but 50 to 100 feet of travel may be necessary to get both drums to full cutting depth. The machine is backed up to cut the sumping-in length and square up the face, and then returned to the intermediate panel point where it again picks up a full cut. Operating conditions are quite variable with a number of cutting conditions to be expected.

There is a need during the cutting operation to keep a reasonably consistent floor and ceiling as the ceiling support system cannot tolerate steps or holes without risk of tipping or twisting. Corrections in drum height to follow coal seam irregularities must be done in small increments so that the pass-to-pass variations are minimal. A conflict of requirements often occurs when a rock out-cropping protrudes into the coal seam over a rather short face length. Support requirements dictate that the rock will be cut, but tool bit wear and breakage and ash limitations would direct that the cutting drum be moved to avoid the rock. At the floor a somewhat different situation exists as in many cases the material layer below the coal seam is a soft clay. Penetration into this seam gives an unstable footing for the ceiling props so care must be taken to avoid cutting into the clay.

A system to automate a longwall mining machine requires some technique to detect the boundaries of the coal seam and to provide a control signal to adjust the cutting drums up or down as needed to stay within the coal. Several designs of coal interface detector (CID) use cutting bit load as a means of sensing the difference between coal shearing and the cutting of either harder (rock or shale) or softer (clay) material. One concept developed in the U.S. in the 1950's resulted in some patents but little apparent interest or application. A later design developed in Britain in

the mid-1960's was used in an automated mining demonstration but was displaced by a system using a nucleonic detection of the coal boundary which allows the option of leaving several inches of coal, a requirement for some mines to provide protection from moisture loss and the subsequent strength deterioration of the ceiling rock. The renewed interest in this program for the sensitized pick CID is to have available a variety of detectors which can be applied to control an automated machine under a large number of seam conditions and requirements. A preliminary review of the sensitized pick CID was done by NASA, so the purpose of this program is to design a data transmission system which could be used to make tape recorded records of bit loads under a variety of coal and rock cutting conditions. These tape recorded data then can be used to define an optimum machine control system logic which would be part of the overall automated miner system. For ease of assembly a telemetry system was selected to transmit data from the drum to the machine frame, although the production system probably will use a built-in slip-ring system which avoids the need for drum-mounted batteries and electronics.

II. SENSITIZED PICK CID CONCEPT

The basis for application of a sensitized pick coal interface detector is the significant difference between the force required to fracture coal compared to that required to fracture rock or soft clay. Since coal is a pre-fractured material it tends to break away along strata planes in relatively large chunks, while rock is homogeneous and breaks up into smaller pieces. Clay is sheared easily. Compressive and shear strengths are greatest for rock, moderate for coal, and lowest for clay, so a transducer which can measure the difference in bit cutting force between these materials can be used to provide cutting drum position control to automate that portion of mining machine operation.

Application of bit cutting force to machine control does have a few unique problems which make the application of this technique rather interesting. First of all, the cutting action of the drum type cutter provides a variation in cutting depth which is a minimum at top and bottom (ceiling and floor) and maximum at the centerline height of the drum. A depth-of-cut diagram generated for typical conditions is shown in Figure 1. These conditions are:

1. Drum Speed = 60 rpm
2. Drum Diameter = 56"
3. Machine Haul Speed = 15 fpm
4. Double Laced Drum - 180° between corresponding bits.

It is reasonable to assume that bit cutting force varies with cutting depth, although the relationship depends upon coal hardness and the sharpness of the instrumented cutting bit. It can be seen from Figure 1 that the forces of concern at the ceiling and/or at the floor are only a small percentage of the maximum force condition at 90° , but the cutting of rock or clay instead of coal at these locations may only double or halve the cutting force and this amount of variation might easily escape detection in the presence of the much greater loads experienced at the maximum cutting thickness condition. As the drum cutting bits wear and dull, the cutting force for the same depth of cut

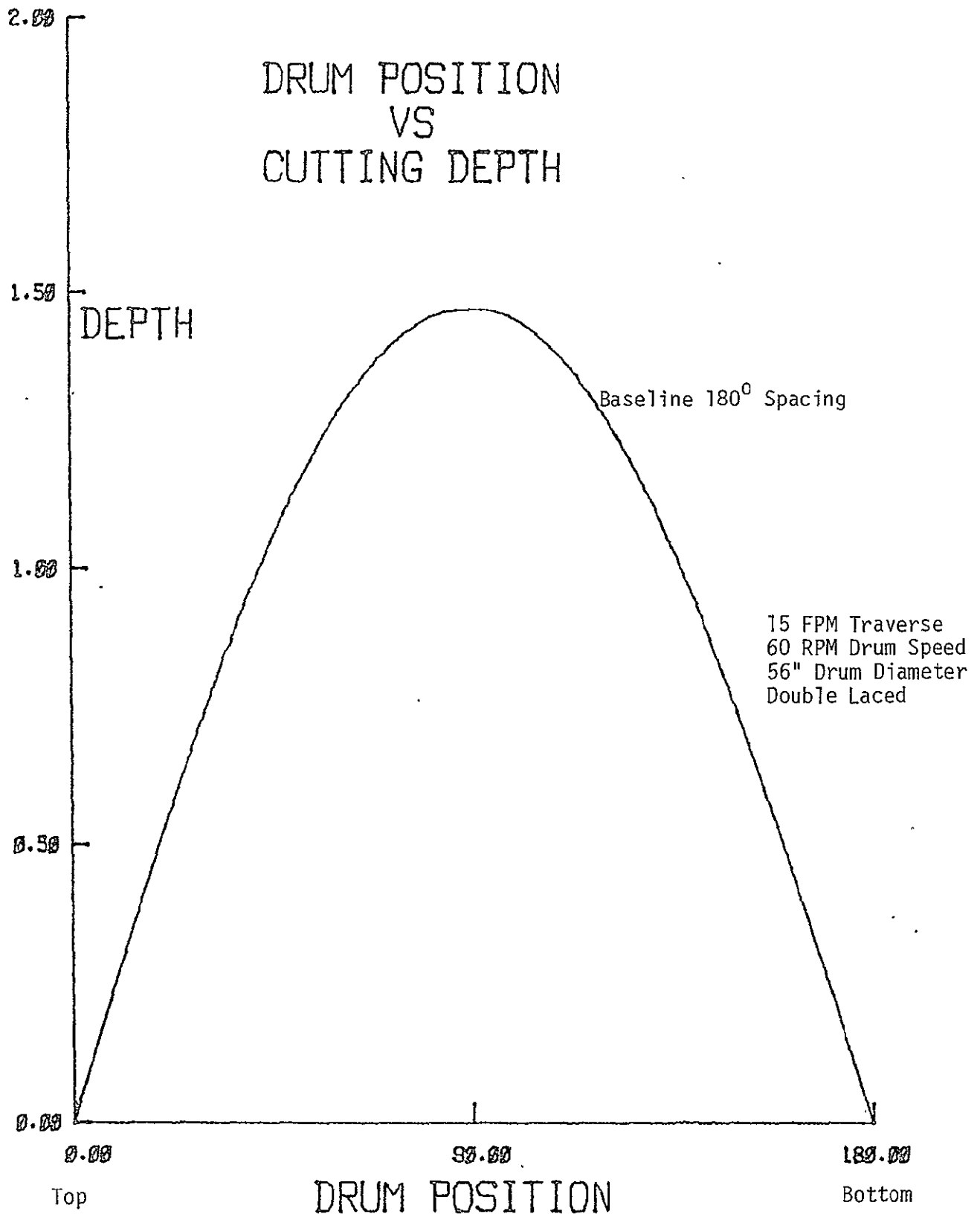

FIGURE 1

will increase, so it seems that some normalizing will be necessary to permit the control system to recognize and compensate for such changes.

A measurement system developed in Britain under National Coal Board Contract (Reference 1) used a cutter bit mounted on an elastic cantilever beam with a displacement transducer to detect loads proportional to beam deflection. The instrumented bit was mounted directly behind and somewhat higher than a normal cutting bit so it could be cutting rock while all other bits were still in the coal seam. A drum position sensor was used so that the ceiling and floor cutting locations could be readily identified. It was reported that the system successfully was used to guide the machine drum position in extended mine usage, but the concept was apparently not advanced because of successes with other measurement techniques. Comments by a machinery manufacturer representative familiar with the British tests indicated that reliability problems were more likely the reason for discontinued use. Typical data from Reference 1 is shown as Figure 2, and this was the only published data found which represented bit dynamic loads in any realistic form.

In application, the sensitized pick output data is processed by an analysis system which can recognize differences in output for normal coal cutting and for various rock or soft clay material cutting. The control for the leading drum of a double drum ranging shearer would move the cutting drum upwards in small increments until rock was detected, then back off a small amount so that only coal was being cut. After some number of drum revolutions the system would again range upward until the seam boundary was reached and then back off, so that the ceiling cut would end up a series of undulations. At the same time, the trailing drum would be driven down toward the lower seam boundary and then brought back as clay or rock was detected. Compensation would have to be built in to allow for variations in cutter bit sharpness, machine traversing speed, and coal strength properties.

Most likely the system would have to include logic which could recognize pass-to-pass variations and insure that subsequent cuts did not leave holes and ridges which would jeopardize the integrity of the ceiling support system.

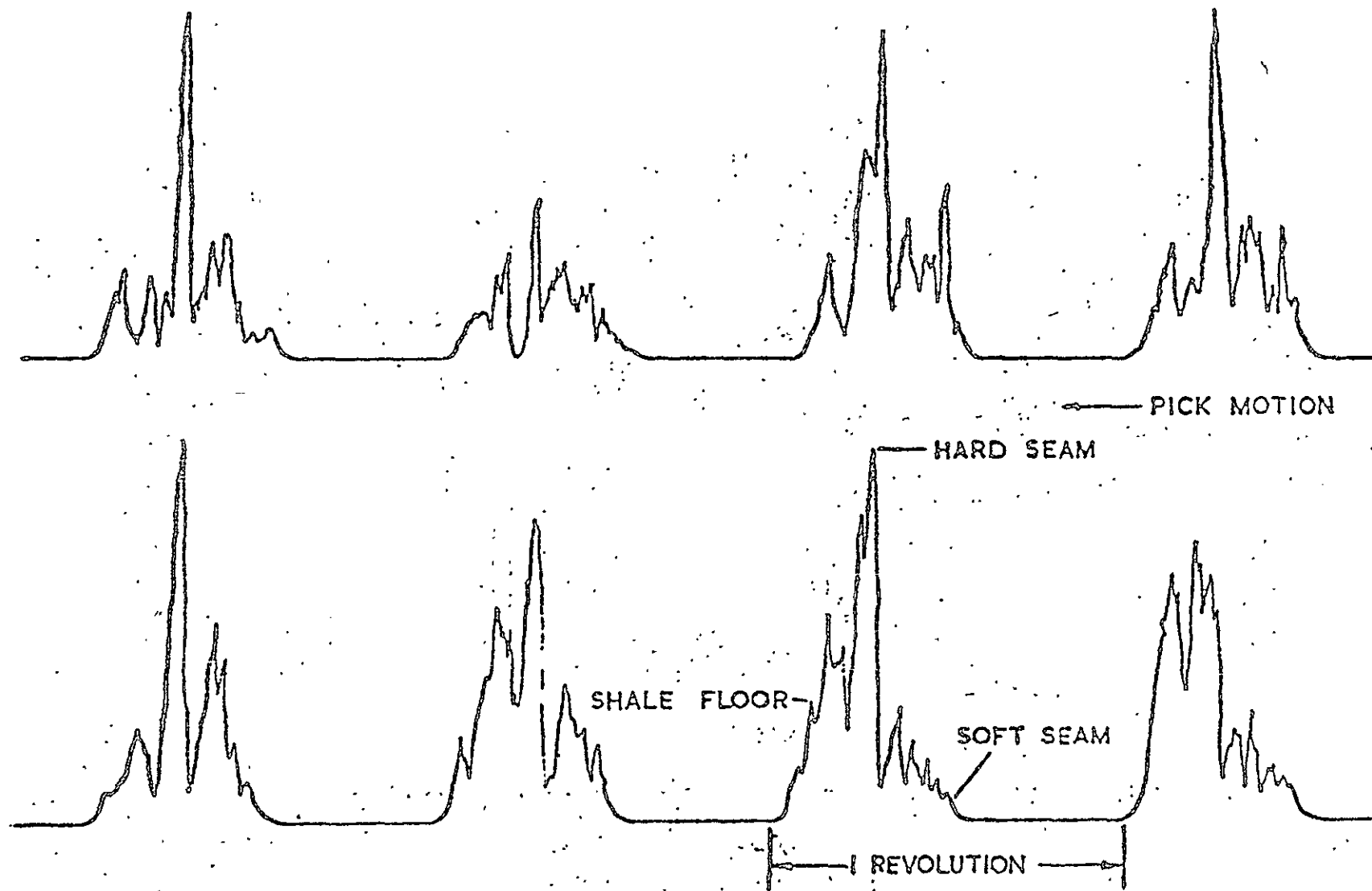

EXAMPLE OF TYPICAL SIGNALS FROM INSTRUMENTED PICK

FIGURE 2

This may mean that some rock would be cut and some coal would be left to provide overall mining system optimization at the expense of ash production, tool wear, and overall recovery.

III. MINE REVIEW AND MACHINE SELECTION

The initial phase of this program was to visit a number of operating mines to identify if possible a prospective test site and mining machine around which a workable data transmission system could be designed. It was felt that a system designed for a specific machine and mine situation would be much more cost effective and efficient than one required to meet universal installation requirements with only general guidelines. Several tool manufacturers were visited to obtain background on bit design criteria and an overview of current tool philosophy. A list of facilities and individuals visited is included as Table 1.

Mines visited had coal seams ranging in height from 39 inches to 90 inches, and it was concluded that working heights of less than 50 inches were very difficult with the equipment packages assembled for data recording. An arrangement was reached with two mine operations that they would consider a proposal to evaluate the sensitized pick concept in their mines. Obviously neither could guarantee cooperation with only a very limited outline of what would be required of the selected site, but both felt that the potential for information return on their investment of mining crew time was well worthwhile.

The primary site selected was the Jane Mine of Rochester and Pittsburgh Coal Company at Indiana, Pennsylvania. Their Eickhoff 150 single drum mining machine operating in 56 inches of coal should provide realistic mining test conditions.

The back-up site is one longwall face of the Fairmont Division of Consolidated Coal Company, near Shinnston, West Virginia. There are several Eickhoff EDW 300 double drum machines operating in seams 78 inches to 92 inches thick in this division which could be available for testing.

A third possible site for sensitized pick coal interface detector testing is at the Bureau of Mines Bruceton Facility using the Joy double drum mining machine purchased for automated miner demonstration tests. This unit is to be set up outdoors for limited cutting of synthesized coal, and it provides

TABLE 1

MINE AND MACHINE SELECTION

VISITS TO:

1. Appalachian Fuel Company, Huntington, West Virginia
(Mr. Ken Winters)
2. Consolidation Coal Company, Itmann #3, Itmann, West Virginia
Pocohontas Division (Mr. Frank Beard)
3. Rochester and Pittsburgh Coal Company, Jane Mine, Indiana, Pa.
(Mr. Gene Jones)
4. Consolidation Coal Company, Mountaineer #95, Shinnston, W. Virginia,
Fairmont Division (Mr. Tony Gemono)
5. Carmet Company, Mine Tool Division, Shinnston, West Virginia,
(Mr. Bill Walker)
6. Kennametal Inc., Mining Tool Group, Bedford, Pennsylvania,
(Mr. Doug Evans)
7. Chas. Philips Tool Company, Mannington, West Virginia, Mining Machine
Rebuild Facility (Mr. Ken Phillips)
8. Eickhoff-National Mine Company, Pittsburgh, Pennsylvania,
(Mr. Mike Schmidt)
9. Mining Engineering Department, West Virginia University,
Morgantown, West Virginia (Prof. E. Sandy)

a unique opportunity to evaluate background noise and data transmission requirements without the restrictions of mine permissibility and production schedules.

An early goal of this design study was to produce as universal and general a data system as was possible so that application could be made to a maximum percentage of the longwall population. This means that two basic cutting bit systems need be considered - the blade type bit and the conical or "plumb-bob" type bit. The blade type bit was chosen for the evaluation when it became apparent that a single measurement device could not be readily designed that would fulfill the specialized needs of both bit designs. Some of the reasons behind elimination of the conical bit were:

1. The requirement that the bit rotate in service to equalize wear eliminated a zero clearance retainer which is deemed necessary for maximum measurement accuracy and frequency response.
2. The cutting action of the conical bit results in a combined compressive and bending load on the bit shank which complicates load sensor design.
3. Recent studies by the Bureau of Mines (Reference 2) indicate that the conical bit produces a greater amount of airborne dust than other bit types due to the high specific energy characteristic for this bit design. (The Bureau has determined that airborne respirable dust generated per unit mass cut increases monotonically with increasing specific energy.)

All three candidate mining machine locations make use of the blade-type cutting bit so the design concepts are at least similar for each. The Bureau machine and the Rochester and Pittsburgh Coal Company machine both use a 3" long bit with 3/4" x 1-1/4" rectangular shank, while the Consolidation machines are using the newer coarse laced 4-1/2" long heavy duty bits by Carmet with 1-9/16" diameter round shanks. Discussions with mine operators and bit manufacturers had indicated a very strong preference toward a measurement system which would allow simple replacement of a standard bit as cutter

bit life in some circumstances is as short as two hours, although normal life is more like two to four days. A design goal then was to separate the load measurement element from the bit to avoid the necessity of throwing away an expensive part of the system.

IV. TELEMETRY SYSTEM REQUIREMENTS

This program was begun with a goal of producing the better of two possible data telemetry systems:

1. A distributed component system with sensing element, transmitter, and antenna located for maximum protection and optimum data transmission.
2. A consolidated drum element containing the instrumented cutting bit, transmitter, battery pack and antenna.

Either system would transmit to a chassis-mounted pick-up antenna and battery powered (MESA permitted) receiver, and the test data recorded on magnetic tape. It was concluded from discussions with NASA personnel that a full frequency range of test data from DC (static) to at least 20 Kilohertz need be evaluated so telemetry requirements were very stringent. A basic performance specification was established and distributed to a cross-section of telemetry system manufacturers requesting information. A list of companies contacted and the telemetry system requirements are included as Appendix I to this report.

Standard production systems meeting major requirements were indicated by two suppliers: Acurex Corporation of Mountain View, California, and Inmet, Incorporated, of Indian Harbour Beach, Florida. Several other companies expressed an interest in developing suitable equipment, but did not have production devices available. The basic conclusions from this market survey were:

1. Transmission of static (DC) strain data is possible using a FM-FM transmitters. Dynamic data to 2000 Hz (Inmet) or 1000 Hz (Acurex) is practical with this technique.
2. Transmission of dynamic strain data is possible using a FM transmitter over a frequency range of from 10 Hz to 90 KHz (Inmet) or 10 Hz to 20 KHz (Acurex).
3. Up to 12 transmitters can be used simultaneously in an array without interference by separating carrier frequencies by 1.5 megahertz (MHz).

4. Temperature and acceleration signals may be transmitted over the same frequency spans as static and dynamic strain using suitable interchangeable transmitters.
5. Two basic antenna systems are generally applied for short range data transmission: capacitive coupling using circular antenna elements one inch or less apart (Acurex) or electromagnetic coupling with whip antennas 3 to 20 feet apart.
6. Normal FM telemetry techniques operate in the frequency range from 88 megahertz to 108 megahertz. The carrier wavelength for this band is from 9 to 11 feet.
7. The radio controls for remote operation of mining machine typically operate at higher carrier frequencies than the range specified here to improve data transmission in narrow tunnels. The Joy mining machine purchased by the Bureau of Mines for automation demonstrations operates at a center frequency of 460 megahertz. (Reference 3). No interference between the two information transmission systems is expected.

For use in gassey coal mines all components must be reviewed by MESA for intrinsic safety, and because of the limited quantities involved, a permit will be requested for the final system. Throw-away batteries with current-limiting resistors will be mounted on the drum to provide transmitter power while rechargeable batteries will be applied for receiver power. Design goals are for a minimum of 100 hours of operation for the transmitter battery and 5 hours of operation of the receiver package between recharge cycles.

V. INSTRUMENTED PICK DESIGN

The first phase of design for the sensitized pick installation was an attempt to find any test measurements of forces present at the bit when cutting coal and when cutting rock. Discussions with mine operators, manufacturers, and mining machine company representatives indicated that while those data may have been taken at some time, no one knew of any published data presenting that information. Based upon the knowledge that on occasion the bits could be fractured by severe cutting requirements, an ultimate load was computed to give a reasonable starting point for a load measurement system. For 100,000 psi maximum bending stress in the 3 inch long shearer bits used in the selected mine sites, a 4100 pound tip load is required, and the reaction force at the lower plane of the bit shank would be 4920 pounds. The preload beam system shown in Figure 3 was conservatively sized so that no element had more than 2/3 the stress level of the cutting bit. Application is as follows:

1. A standard cutting bit is inserted into the broached pick mount cavity by driving it past the pick retaining plug.
2. The zero load strain output of the strain gaged load sensor is read out on the telemetry receiver output meter on the machine base.
3. The preload bolt is tightened until a static strain of approximately 1/3 of pick allowable strain is indicated. The lock nut jams the preload bolt in place;
4. Static and dynamic changes in cutting bit load are indicated by load sensor strain outputs. The preloaded beam insures that the load sensor stays in intimate contact with the cutting bit.
5. When necessary, the cutting bit may be removed and discarded by releasing the lock nut and preload bolt and pulling the bit using a standard pry tool.

This special bit block is mounted in place of a standard block on the long-wall cutting drum. A metal tube directs the transducer leads to a transmitter/battery assembly mounted in the web of the drum as shown on Figure 4. All electronic components and lead wires are installed after the support components are welded in place.

C-2

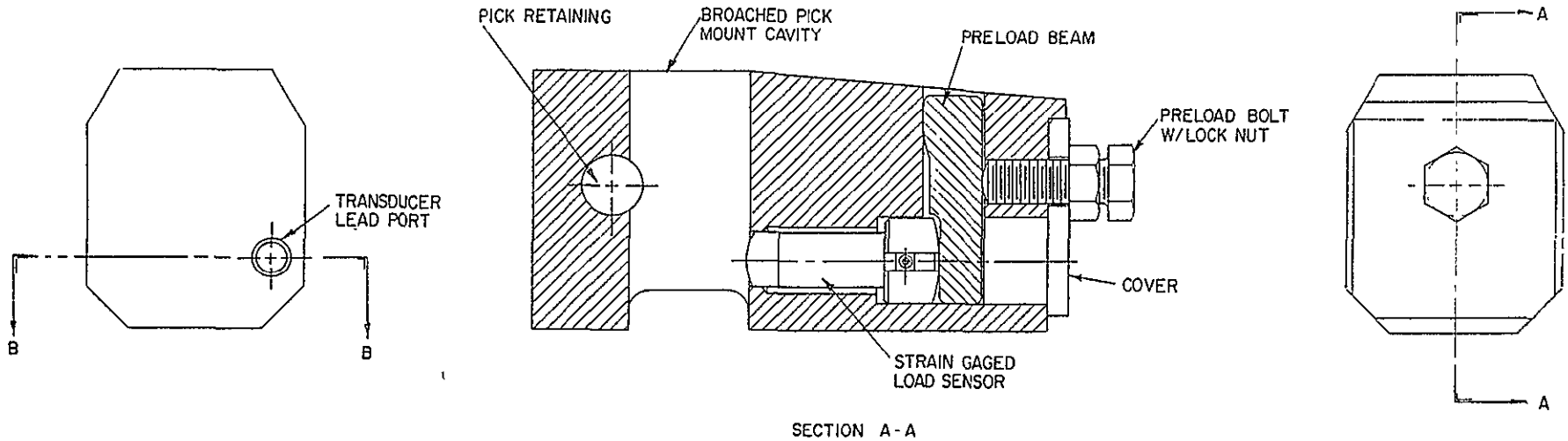
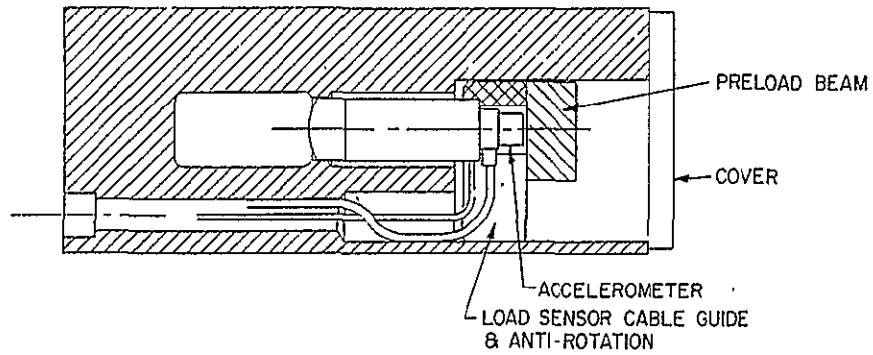

INSTRUMENTED PICK BLOCK

FIGURE 3

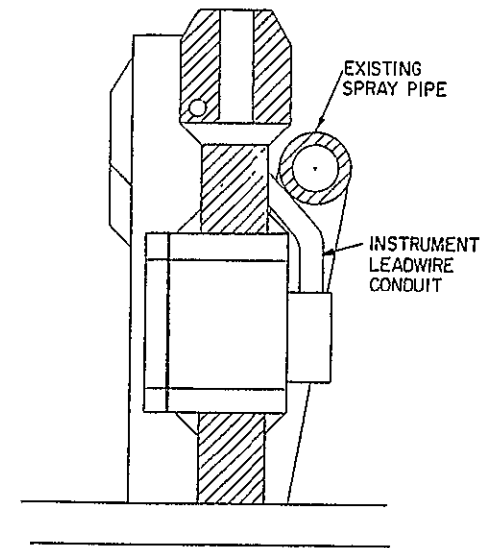
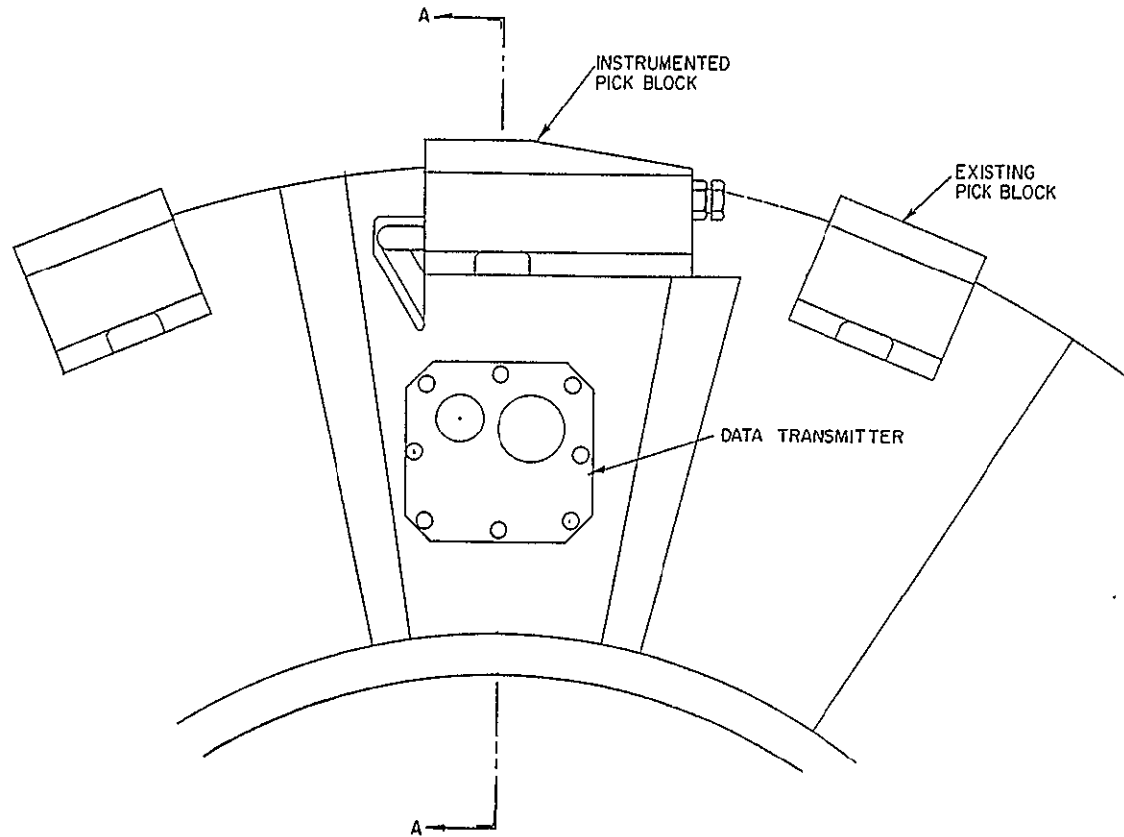
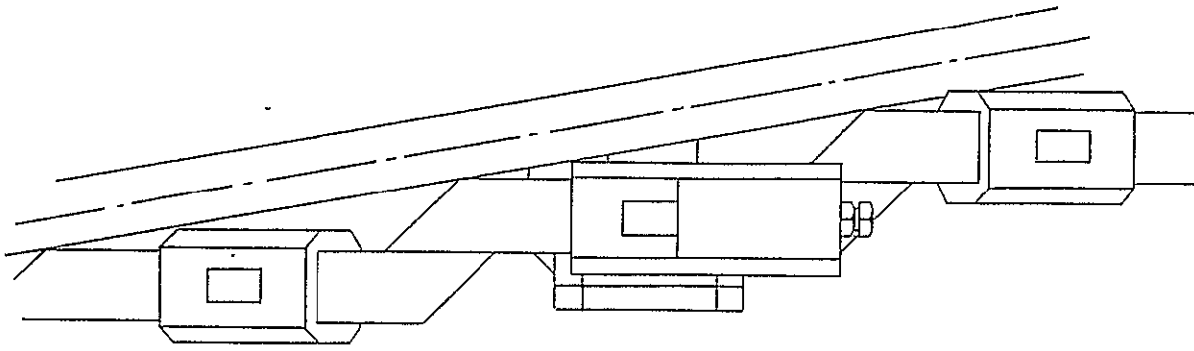

INSTRUMENTED PICK BLOCK AND TRANSMITTER
MOUNTED ON JOY MINER DRUM

FIGURE 4

The spiral web of the cutting drum "pumps" the cut coal into the face conveyor as it turns, but the outer (machine side) edge does only minimal work so this mounting location is acceptable. The details of construction of the telemetry transmitter assembly are shown on Figure 5. Major elements are: 1) strain gage FM-FM telemetry transmitter for DC to 2 KHz strain response, 2) a 12 volt current-limited battery pack, 3) accelerometer FM telemetry transmitter for 10 Hz to 90 KHz acceleration response, and 4) two 75 ohm resistor transmitting antennas radiating through non-metallic antenna covers. The accelerometer transmitter is an alternate to a FM dynamic strain transmitter which would be used if high frequency strain is the preferred measurement technique. The concept pick shown in Figure 4 includes the alternate of pick shock response as well as pick load as a measure of the cutting character of the material at the bit. It is assumed that shock energy levels for the bit striking rock or clay will be dramatically different from those from normal coal cutting operation. The impacts of cutting will cause the pick to vibrate at a number of its cantilever beam resonant frequencies, with the amplitude of response proportional to the impact energy and to system damping. Lower order modes are moderated significantly by damping as displacement amplitudes are large, but higher mode responses tend to be very pure as damping becomes less of an influence. Shaker Research Corporation has applied high frequency vibration response techniques to a variety of machine element problem detection tasks and we have found that impact characterization in the frequency range of from 15 KHz to 50 KHz is an extremely useful way of monitoring performance differences. Ball bearing rolling contact difficulties, gear train surface faults, pump fluid cavitation conditions, and machinery rub problems have been detected using the structural ringing of machine elements as a carrier of information to areas outside the direct fault site. The concept is implemented here by attaching a suitable high frequency response accelerometer to the end of the compression member loaded against the bottom of the bit so that the minute shock response amplitudes of the exposed end of the pick might be measured.

The complete telemetry data transmission system is shown in block form on Figure 6. It is assumed that two sensitized pick coal interface detectors

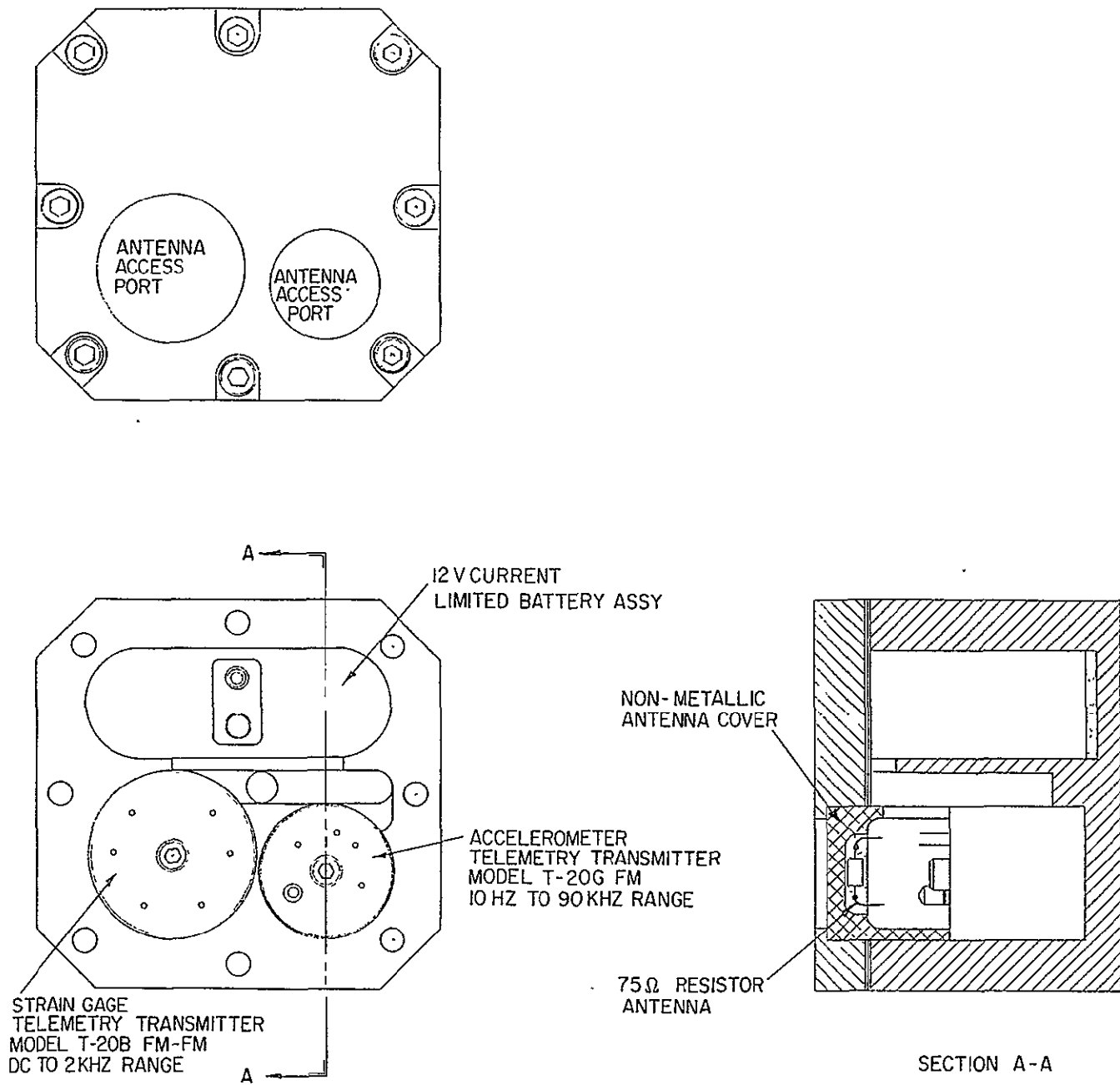

TELEMETRY TRANSMITTER ASSEMBLY

FIGURE 5

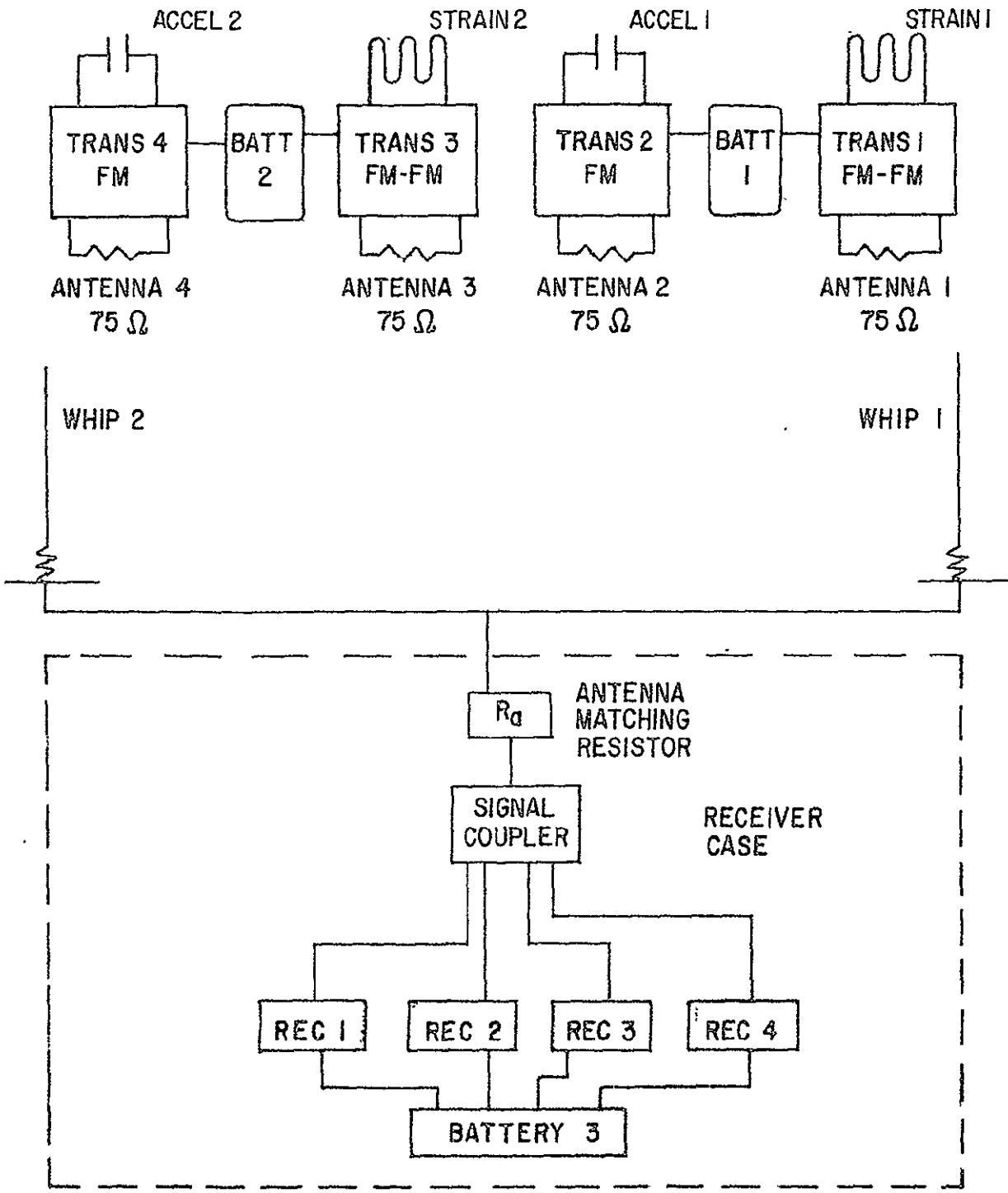

DATA TRANSMISSION SYSTEM
SENSITIZED PICK DETECTOR

FIGURE 6

(CID's) are applied either to evaluate alternate arrangements, for more definition of the same configuration 180° apart on one drum, or for ceiling and floor cut drums on a double drum mining machine. A choice was made to use 75 ohm resistor transmitting antennas and whip receiving antennas (dual whips with co-phased lead-in cable) with electromagnetic signal transmission. The close-coupled capacitive data transmission system was rejected because of installation space requirements in the drum hub area. The swinging cowl assemblies of double drum machines use up the required axial length needed for this type of radio wave transmission. The whip antennas are located as far away from each other as practical to take advantage of alternate data transmission paths from each transmitting antenna. One advantage of using the standard FM carrier bands is that blockage of carrier waves requires an obstacle that is one half wave length or greater in dimension, a span of five feet or more. There are few such obstacles around a longwall machine, and by taking advantage of reflections and multiple paths the widely spaced whips will be able to pick up continuous signals from all four transmitters. The lower dashed envelope shown on Figure 6 defines the contents of a receiver case which is mounted on the mining machine frame. The whip antenna signals pass through an adjustable antenna matching resistor which can be tuned to maximize antenna gain. A passive signal coupler splits the signal to each of four receivers so that the individual transmitter outputs are separated and made available for recording on four channels of a seven channel tape recorder which will be used to make permanent record of test data outputs. A solid-state 12-volt current limited battery pack has been designed to permit operation of all four receivers for six hours or more before recharging is necessary. Figure 7 shows the general configuration of the proposed receiver package. It contains two FM receivers and two FM-FM receivers (all by Inmet, Inc.) so that two complete CID systems can be monitored over a frequency range from DC to 90 KHz with accurate determination of pick parameter output amplitudes. The unit is packaged in an aluminum case suitable for airline shipment, and weighs approximately 65 pounds. The size and weight are reasonable for handling by one person, and can be mounted on a longwall mining machine without great difficulty.

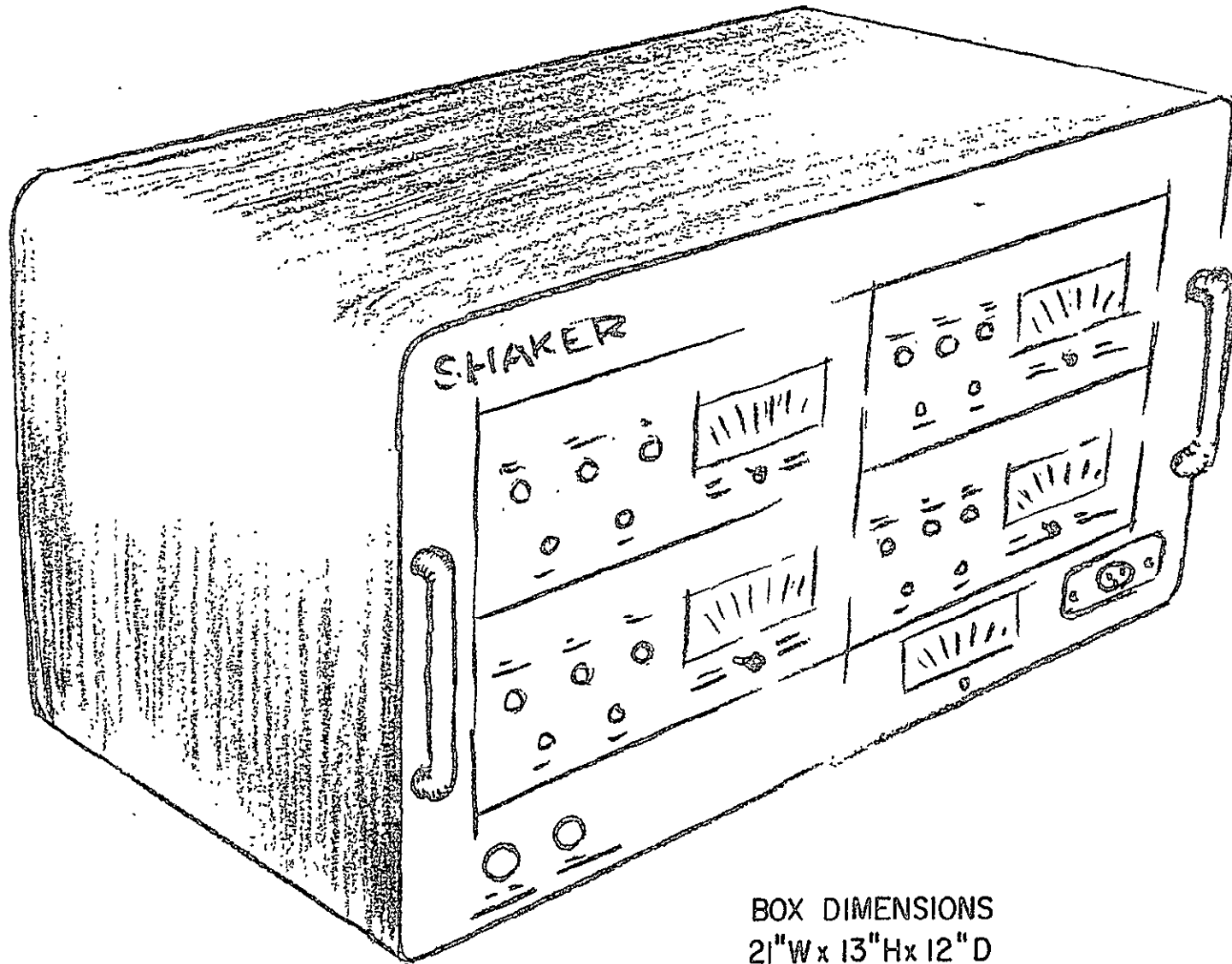

SHAKER RESEARCH 4 CHANNEL TELEMETRY SYSTEM

FIGURE 7

VI. ALTERNATE CONCEPTS

Several questions about the optimum application of the sensitized pick coal interface detector cannot be answered until some additional testing has been accomplished. The basic concern is for detection of differences in output for coal cutting versus rock or clay cutting at the very top (0°) or very bottom (180°) when the depth of cut is only a fraction of an inch as shown by Figure 1. Maximum sensitivity is desired at these probable foreign material locations, but in another 90° of rotation, the transducer system must withstand a full depth of coal cut which may be 1-1/2 to 2 inches thick. Several schemes have been put forward to minimize this problem:

1. Provide a mechanical stop so that high sensitivity is available for light cuts but a substantial limit is reached before the tool begins to absorb the full depth cut stress.
2. Provide a broad dynamic range transducer system so that very fine resolution can be attained over light and heavy cuts.
3. Mount the instrumented cutting bit right behind another bit (in its shadow) so that the depth of cut is less than the 1-1/2 to 2-1/2 inches normally experienced, and is in fact almost a constant depth cut from ceiling to floor.

The first technique has a real advantage in sensitivity as a mechanical stop can take the extremes of operating loads experienced from sulfur ball inclusion encounters or unavoidable operation with dull bits. However, the design of a linear system with stops may require machining precision and cutting cycle definition which will not be available until significant study has been done. (Another disadvantage of this system is that linear measurement of forces during maximum thickness cutting of coal is probably the best way of judging the sharpness of the cutting bits. Normalization of bit load data for different cutting edge conditions will almost certainly be required for any long term operating control system.)

The second technique has the primary advantage of complete compatibility with normal drum lacing techniques. The instrumented pick experiences absolutely typical loads and shocks, and the data output would be most useful to

machine operators and cutting bit suppliers for improving overall machine performance. However, the application of these data to a machine control logic system will be quite difficult and may require much more sophisticated pattern recognition capability to produce drum control ranging signals. Most definitely these measurements should be made to advance understanding about the drum shearing process.

The third pick arrangement has several attractive features which lead this writer to believe that a variant of it will be used in any production version of this transducer system. Figure 8 shows two possible examples of shadow pick mounting: one directly behind the next pick (single spaced), and the second two picks back (double spaced). For the Joy machine purchased by the Bureau of Mines, the single-spaced pick is 15° behind its lead pick, and the double-spaced pick is 30° behind.

In order to evaluate various combinations of shadow pick cutting depths a simple program has been assembled in computer Basic language which can accommodate variations in drum diameter and speeds, traverse velocity, angular offset, and pick extension. Appendix II contains the program as set up on a Wang 2200B programmable calculator. The base-line case shown on Figure 1 was for a standard drum with two bits 180° apart in each cutting plane. Zero degrees is the ceiling and 180° is the floor with the maximum depth of cut equal to 1.5 inches when the cutting bit is at 90° .

For a shadow pick located 15° behind the next pick, the cutting depths are shown on Figure 9 for a standard length bit and for one extended 0.15 inch, 0.25 inch, and 0.50 inch beyond the nominal bit radius. The base-line case from Figure 1 is also shown. Note that the depth of cut for any of the extended bits becomes almost a constant throughout the 180° arc, so evaluation of the hardness of the material at ceiling and floor is greatly simplified because it can be compared directly with the average cutting force for the main seam cut. Variations in machine traverse velocity or bit sharpness are taken care of automatically, reducing significantly the "intelligence" required in circuitry to digest cutting bit outputs. Figure 10 shows the same bit extensions for a pick 30° behind its leader. The conclusions are the same as for the 15° pick except that the greater

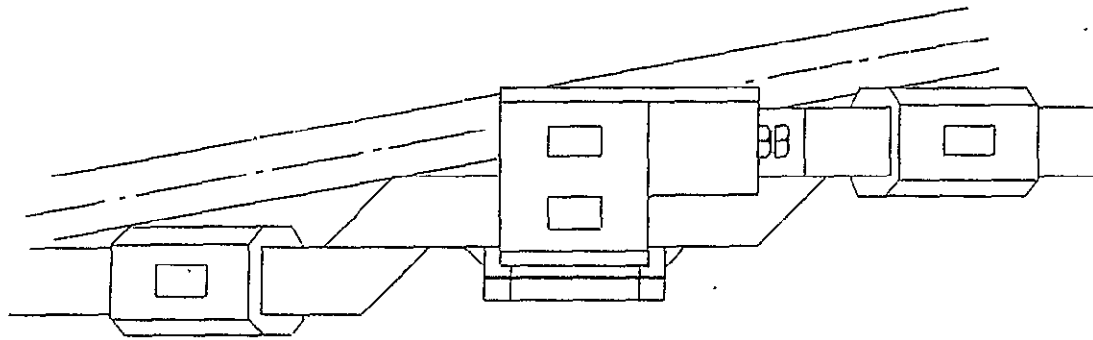

SINGLE SPACED

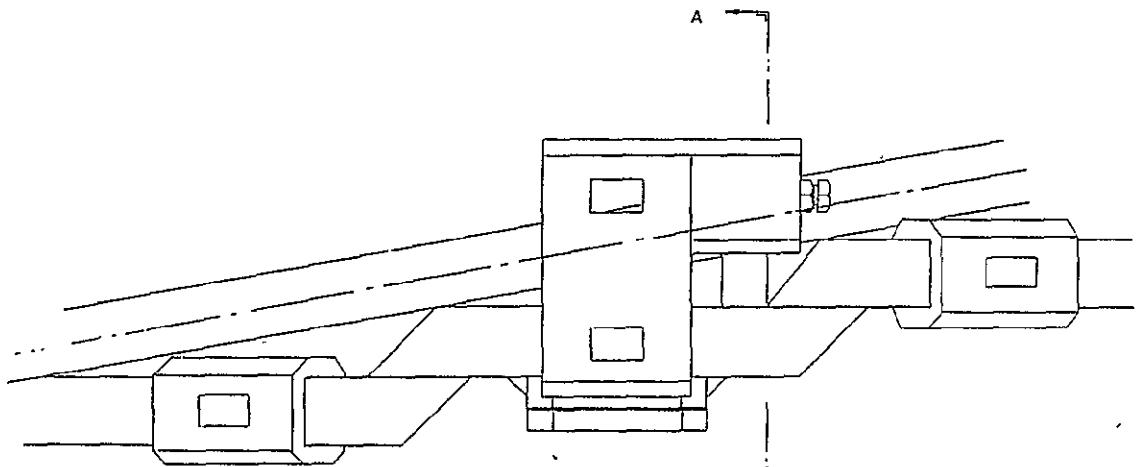

DOUBLE SPACED

SUPPORT GUSSET (TYP)

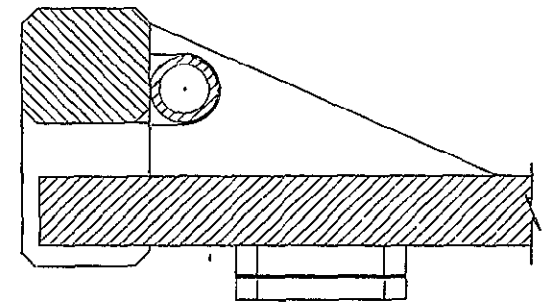

SECTION A-A

EXAMPLES OF SHADOW PICK ARRANGEMENTS

FIGURE 8

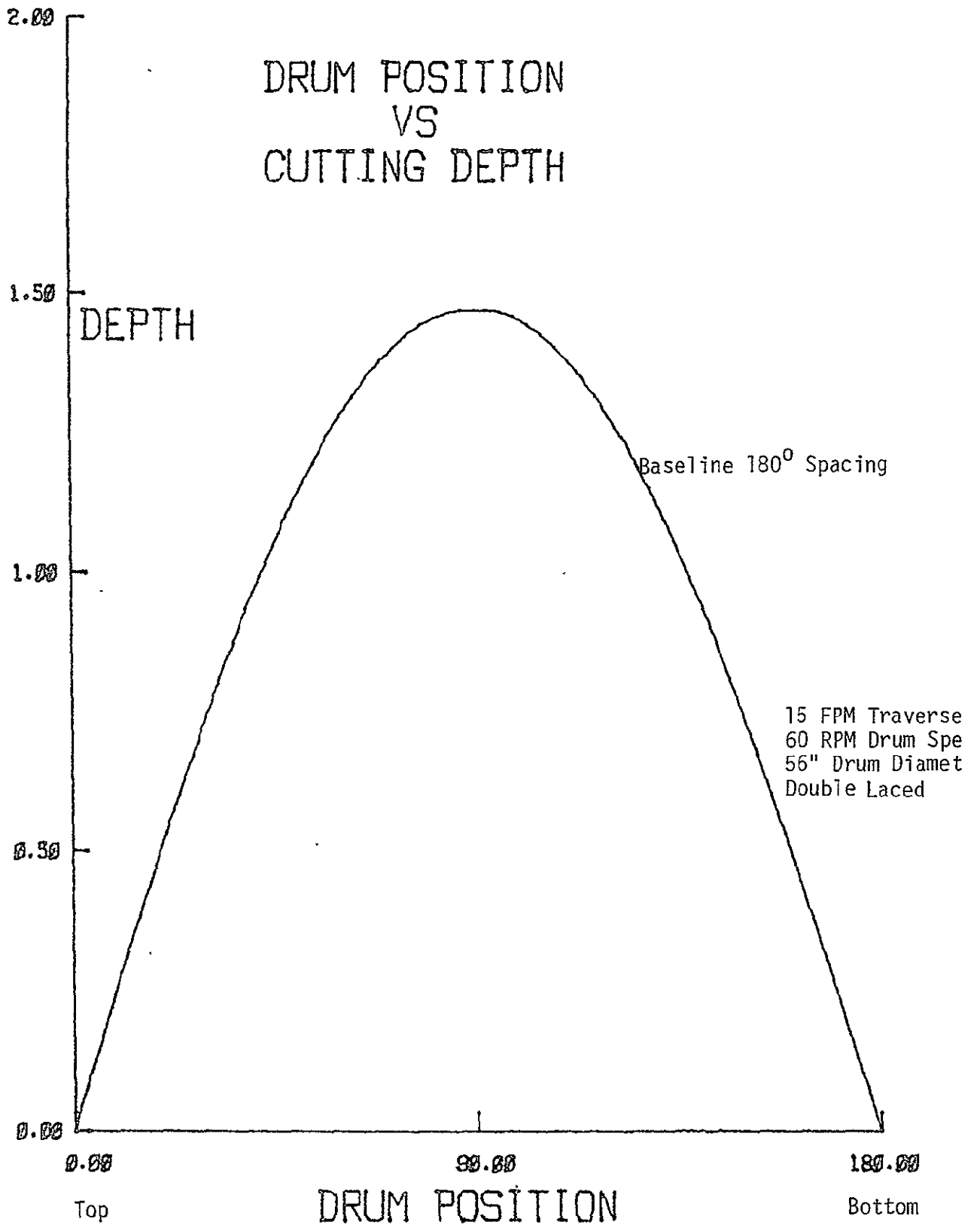

Figure 1 (Repeat)

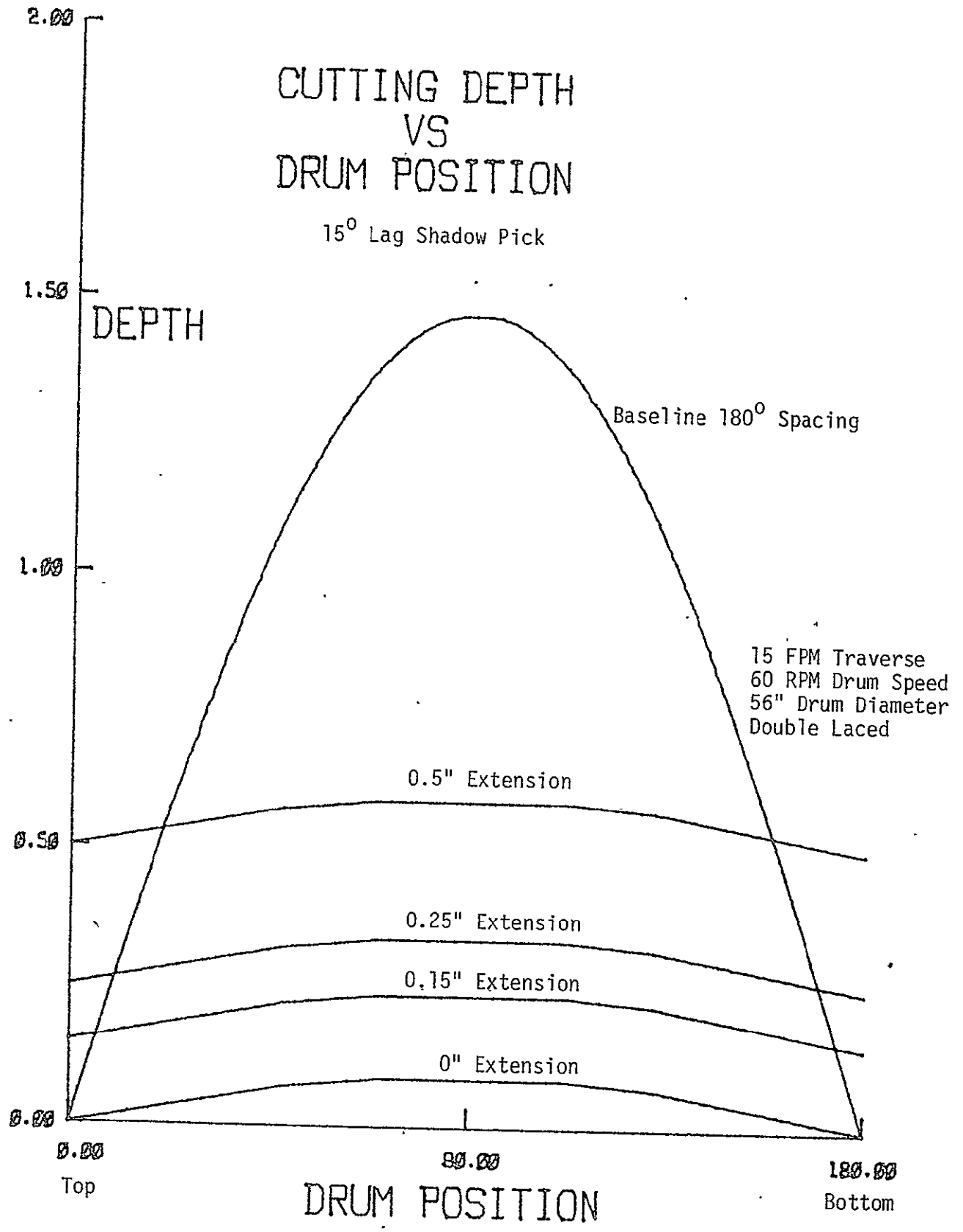

FIGURE 9

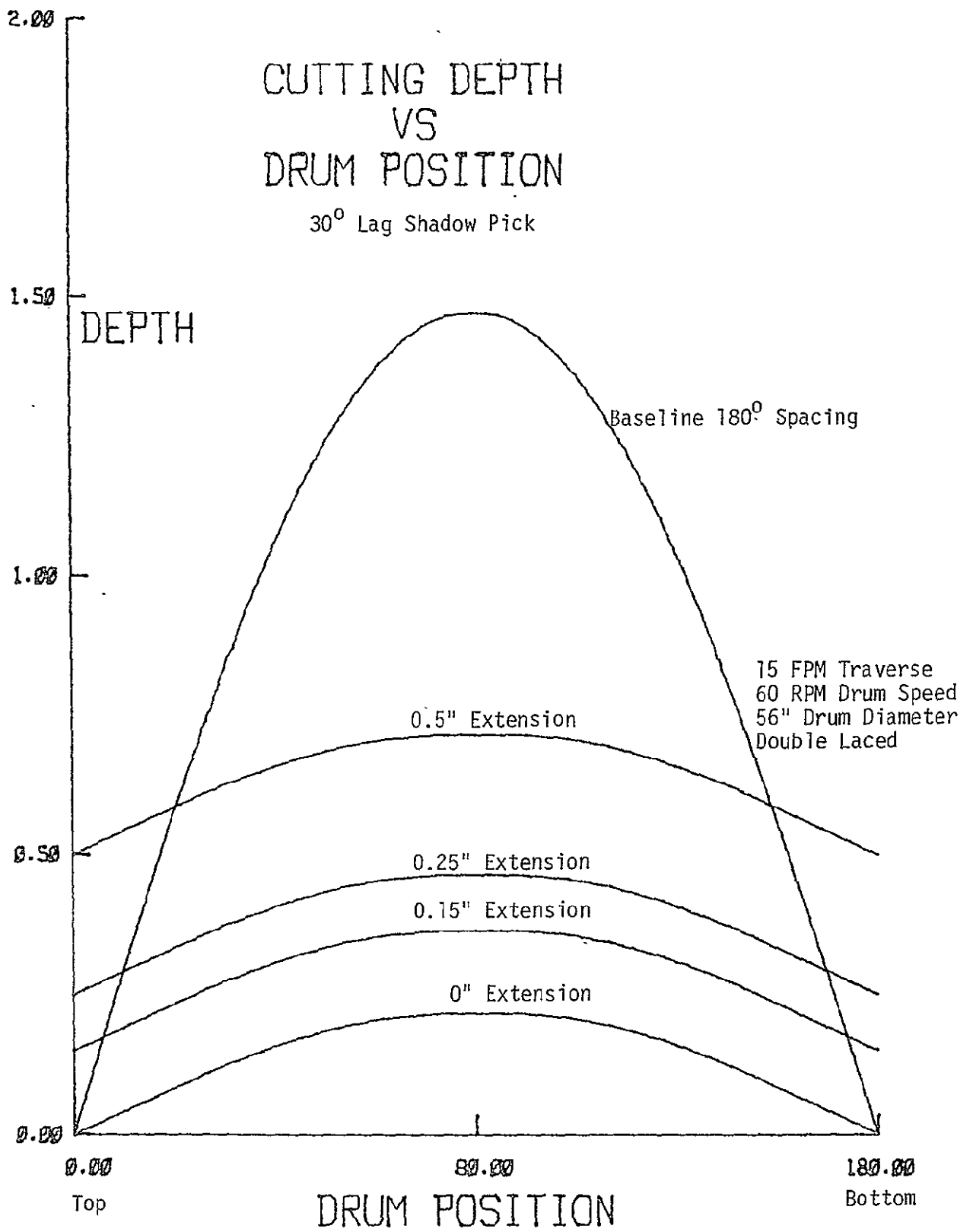

FIGURE 10

lag causes increased difference in cutting depth from initiation of cut through maximum depth.

It would seem from these plots that a 1/2 inch extended sensitized pick placed about 15° behind a normally located bit would provide good cutting characterization with moderate wear. A maximum amount of coal could be recovered with minimal ash and rock cut. To define the presence of very soft material it may be desirable to include a drum angular position indicator so that ceiling and floor locations are readily recognized for the initial evaluations at least an angular position sensor should be recorded along with pick output data and a voice commentary of operating conditions.

After the initial design of the telemetry transmitter assembly was completed a review was held with the operators of the Jane Mine at Indiana, Pennsylvania to obtain some general reactions to the proposed installation. The reception to the concept was generally good, but it was suggested that a surface mounting for the transmitter block would be more easily attached and would require less modification to the drum. With that in mind, an alternate mounting was designed which should minimize attachment concerns. The details of the alternate mounting are shown on Figure 11. Overall dimensions are 4-1/2 inches by 5 inches x 2 inches thick. Figure 12 shows the installation of the surface mount transmitter assembly with an additional bolt-on guard to protect the instrument lead tube from mechanical damage.

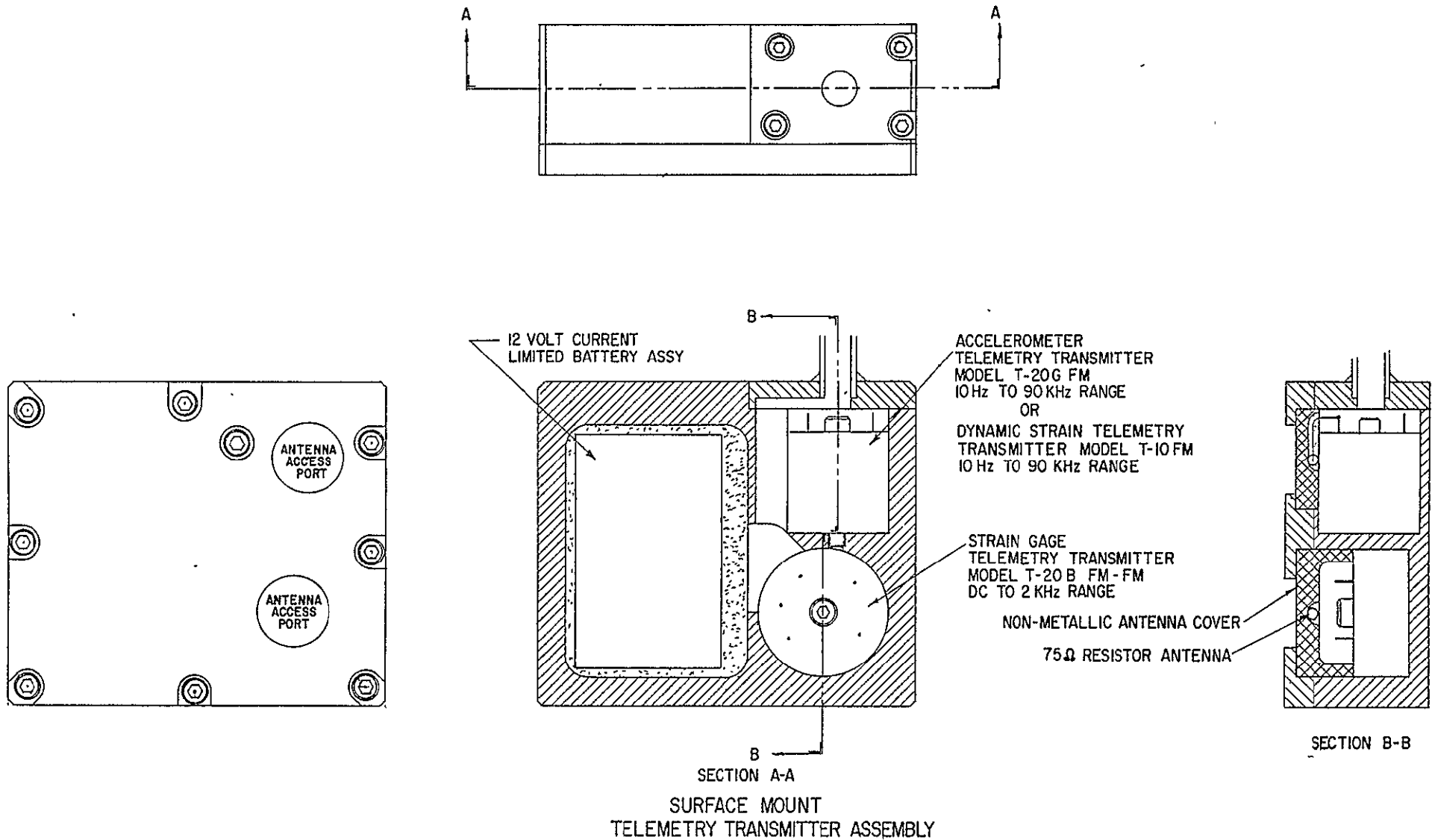

FIGURE 11

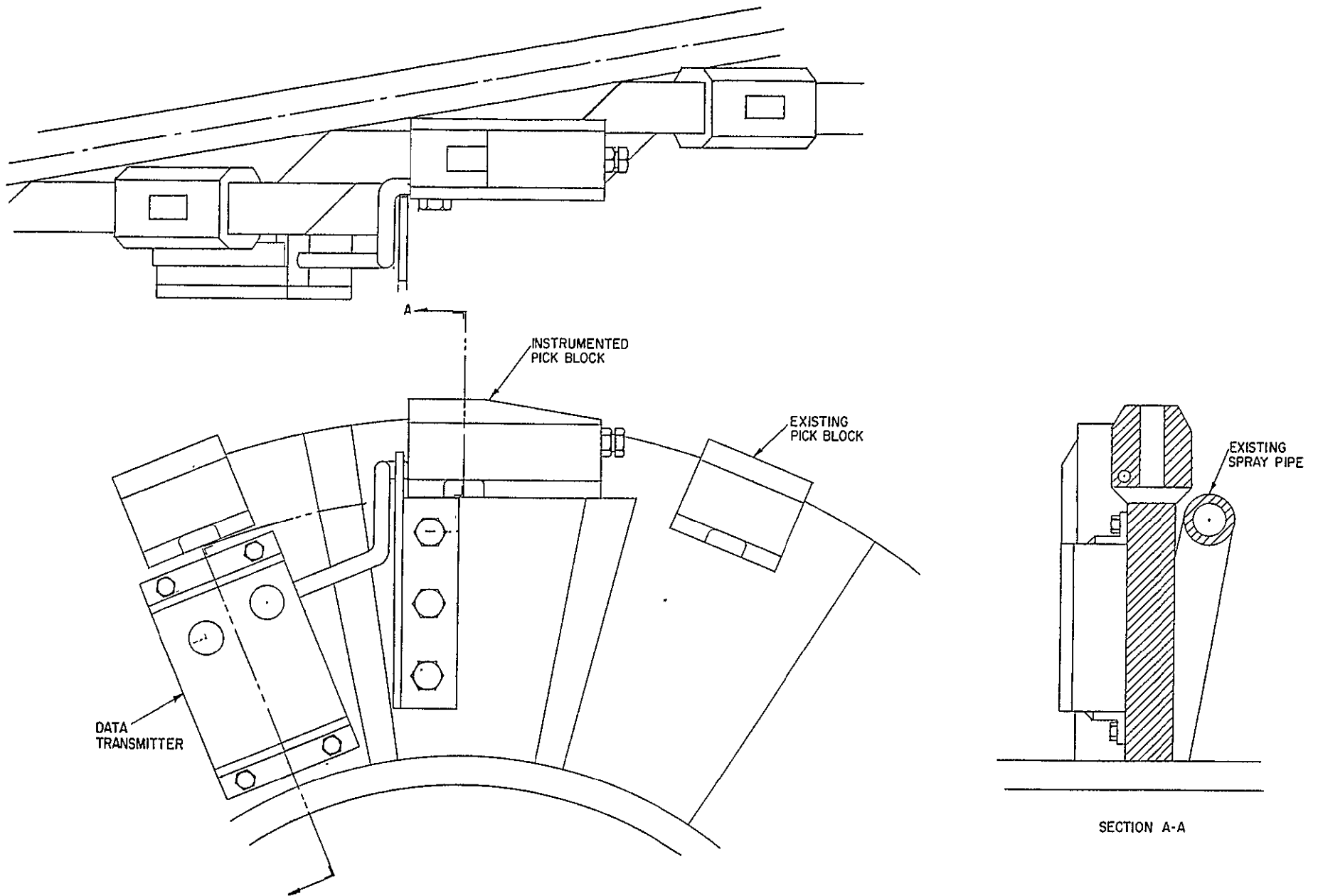

FIGURE 12

INSTRUMENTED PICK BLOCK AND SURFACE TRANSMITTER
MOUNTED ON JOY MINER DRUM

VII. RECOMMENDED EVALUATION PROGRAM

It is recommended that the sensitized pick CID data transmission system be implemented with a mine demonstration so that detailed magnetic tape data can be made available for definition of control logic analysis. These test data are not presently available in any suitable form and are a necessary step in the application of a promising machine control technique.

Application of the telemetry system is visualized as a three-part program. The initial phase includes the finalizing of the receiver package design, procurement of components, assembly and laboratory checkout. Concurrently with this activity the necessary MESA and State of Pennsylvania permits and approvals will be obtained to satisfy intrinsic safety requirement for use in gassey coal mines.

For the second phase of this program, it is suggested that the telemetry system be taken to the Bruceston automated longwall demonstration site and attached to the Joy mining machine for evaluation of telemetry output characteristics and as a check for interference with the remote control instrumentation system used with that machine. The influence of RF fields around electrical components can also be evaluated, and an initial evaluation of telemetry antenna location can be accomplished. Checkout with this machine would insure minimum difficulties in the underground test phase.

The mine demonstration phase of this program is planned to provide examples of normal pick dynamic load conditions with a number of variations which can direct the selection of an optimum measurement system. For control, it is suggested that one standard bit location be instrumented with strain and acceleration transducers and monitored throughout the test. At a location 180° around the drum a shadow pick arrangement should be installed which follows as closely behind its lead pick as possible. The output of the shadow pick with a standard bit, one 0.25 inches longer than normal, and one 0.50 inches longer than normal installed should be recorded while operating in a variety of materials (coal, rock, and clay) along with the output of the control pick. In addition, a phase indicator which produces

a voltage pulse at a known angular drum position should be recorded concurrently with strain and acceleration measurements, as well as a voice commentary describing the operating conditions.

If practical a measure of machine traverse velocity should also be made simultaneously: one possible scheme is to count links as the haulage chain is pulled through. The seventh channel of the analog tape recorder can be used to record machine background sound level or acceleration to further characterize the operating environment.

Installation of the sensitized pick CID data transmission system appears to be possible at the Jane Mine of Rochester and Pittsburgh Coal Company. A detailed explanation of installation and operational requirements for this system was presented to the operations management of that mine, and assurance was given that they would aid us in obtaining the required test information. Successful completion of this program in a reasonable time schedule appears to be completely practical.

VIII. REFERENCES

1. Ferrier, E. J., and Field, J. D., "An Automatic Sensing and Guiding System for Coal Extraction Machines", EMI Electronics, Limited, Middlesex, England.
2. Roepke, W., Lindroth, D. P., and Myren, T. A. A., "Reduction of Dust and Energy During Coal Cutting Using Point-Attack Bits", 1976, Bureau of Mines, RI 8185.
3. Warner, E. M., "Cable and Wireless Remote Control of Continuous Miners", Joy Manufacturing Company, published in Mining Congress Journal, October, 1974.

APPENDIX I

TELEMETRY SUPPLIER SURVEY

SURVEYED TELEMETRY SUPPLIERS

July 2, 1976 Inquiry Letter

General Instruments Corporation	Inscom Electronics Corp.
Harris Corporation	Kinetic Systems Corp.
Motorola/Phoenix	Ledex Inc.
EMR Telemetry	Lynch Communication Systems Inc.
INMET	Martin-Decker Company
Conic Corporation	Microm Systems Inc.
Household Data	North Electric Company Electronetics Division
Zeta Labs, Inc.	North Hills Electronics Inc.
Da-Tel Research Company	Pacific Communications Inc.
Enviromarine Systems Inc.	QEI Inc.
Environmental Communications Inc.	Receptors Inc.
Non-Linear Systems Inc.	Repro Inc.
Phoenix Data Inc.	RFL Industries, Inc. Communications Division
Signal Labs Inc.	Ring-Master Inc.
Solid State Electronics Corp.	Sonex Inc.
American Electronic Labs Inc.	Teledyne Telemetry Company
Base Ten Systems Inc.	Telemetry Systems Engineering Inc.
BF Electronics	Tri-Com Inc.
Bicom Inc.	Sensors Inc.
Dataprobe Inc.	Judson Research
Electrac Inc.	Opcon Inc.
Fisher Pierce Division, Sigma Institute	Advanced Kinetics Inc.
F&M Systems Company	Electro-Optical Industries Inc.
Harris Corporation Electronic Systems Division	Infrared Industries Inc.
Hekimian Labs Inc.	Accurex
Hermes Electronics Ltd.	



RESEARCH CORPORATION

Northway 10 Executive Park
Ballston Lake, New York 12019
Tel. (518) 877-8581

July 2, 1976

Shaker Research is in need of a commercially available device that can transmit analog data over a distance of less than 5 feet. The device must operate under adverse conditions since it will be used on a coal mining machine. The transmitter will be located on a 5 foot diameter rotating drum (60 rpm) and must transmit the data to a stationary part of the machine. The device must stand up to water, grit, and dust. The required electrical specifications are as follows:

Data Frequency Range, Minimum	: 100 Hz to 5 KHz
Data Frequency Range, Preferred:	: 10 Hz to 15 KHz
Dynamic Range	: 50 db
Power	: battery operated, 10 watts max.
Battery Life	: 12 hours, minimum
Desirable Option	: data simulator for test
Input	: for use with strain gage transducer
Accuracy	: ± 1 db, preferred; ± 3 db, maximum

The mechanical specifications are as follows:

Size	: 1 inch cube, maximum
Vibration	: 500 g's
Temperature:	40°F to 90°F
Must have ability to be encapsulated	

The data transmission path may not be ideal due to coal, rock, dust, and water. This area is open for discussion.

Future work may require further miniaturization and/or distribution of components.

If you have such a device, please contact me as soon as possible. We will initially require three devices and technical help for proper installation.

Sincerely yours,

Norman J. Petersen

APPENDIX II
COMPUTER PROGRAM FOR
DRUM DEPTH-OF-CUT ANALYSIS

This Appendix contains a brief description of the technique used in estimating the depth of cut of a lagging drum pick. The computer program used to generate Figures 1, 9 and 10 in the text is also contained herein.

Figure A is a vector diagram of two cutting picks mounted on a drum which moves at a constant velocity (v). By inspection of the diagram it is noted that the cutting depth at the drum position angle α for small offset angles (θ) can be approximated by the sum of two components. Namely

$$\text{Cutting Depth} = \Delta R + R_x$$

where

$$\Delta R = R_2 - R_1$$

and

$$R_x = \text{the projection of } (v \cdot t_\theta) \text{ along } R_1$$

Since the drum is rotating and translating at a constant rate, the displacement projection of $(v \cdot t_\theta)$ in the direction of R_1 can be estimated by

$$R_x \approx v \cdot \sin \alpha \cdot t_\theta$$

where t_θ is the time in seconds it takes the drum to rotate through the angle θ and is given by

$$\frac{60 \cdot \theta}{2\pi N (57.295)}$$

where

θ = offset angle, degrees

N = drum rotation rate, rpm

The depth of cut of the lagging pick is then

$$\begin{aligned} \text{Depth} &= \Delta R + \frac{60 \cdot \theta \cdot v \cdot \sin \alpha}{2\pi N / 57.295} \\ &= R_2 - R_1 + \frac{60 \cdot \theta \cdot v \cdot \sin \alpha}{2\pi N / 57.295} \end{aligned}$$

The computer code calculates the depth of cut at 3° intervals over the forward moving semicircle and plots these results. For a standard double-laced drum, the offset angle is 180° and $R_1 = R_2$. The printout of the base-line case plotted as Figure 1 follows as Table A. Table B is the program printout.

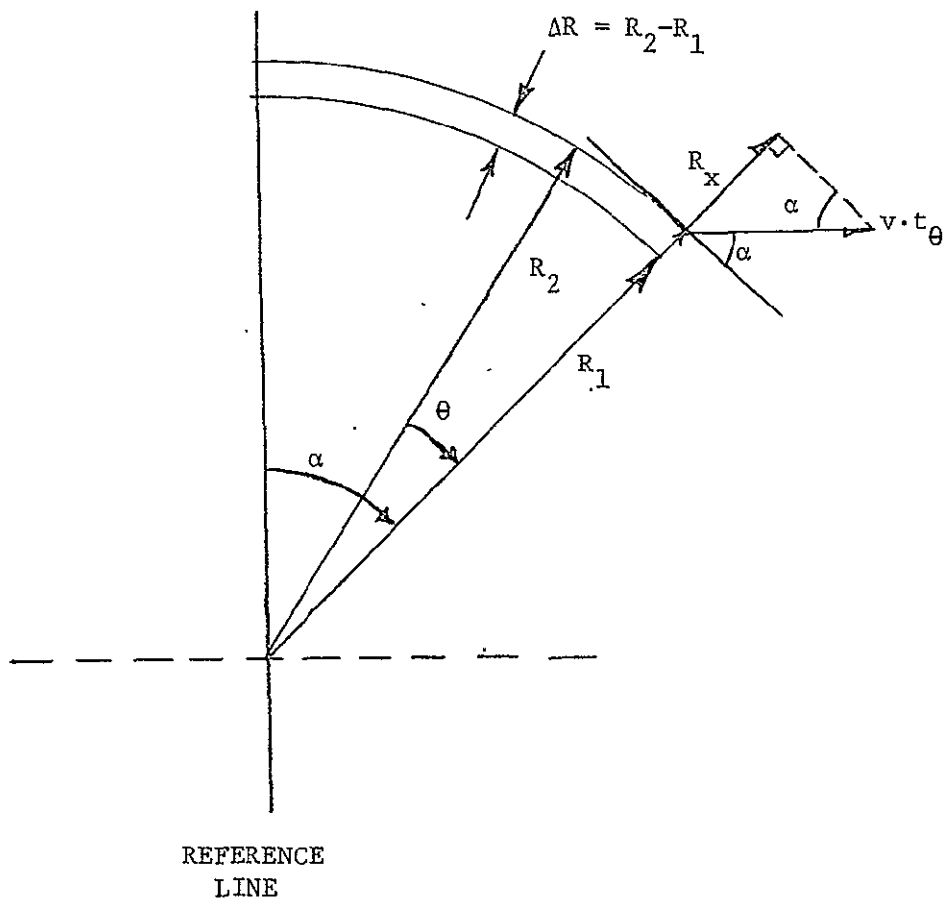

R_1 = Leading Pick Radius

R_2 = Lagging Pick Radius

$\Delta R = R_2 - R_1$

θ = Pick Offset Angle

α = Drum Position Angle

v = Drum Horizontal Velocity Vector

t_θ = Time to Rotate Drum Through Angle θ

Figure A

Vector Diagram For Use In Estimating Depth Of Cut By Pick (R_2)

TABLE A

TEST CONDITIONS

OFFSET (DEG) = 180
 PICK R1 (IN) = 28
 PICK R2 (IN) = 28
 R2-R1 (IN) = 0
 VELOCITY (IN/S) = 3
 ROT. SPD. (RPM) = 60

ANGLE (DEG)	DEPTH (INS)	ANGLE (DEG)	DEPTH (INS)	ANGLE (DEG)	DEPTH (INS)
0	0.00000	60	1.29903	120	1.29903
3	0.07850	63	1.33650	123	1.25800
6	0.15679	66	1.37031	126	1.21352
9	0.23465	69	1.40037	129	1.16571
12	0.31186	72	1.42658	132	1.11471
15	0.38822	75	1.44888	135	1.06066
18	0.46352	78	1.46722	138	1.00369
21	0.53755	81	1.48153	141	0.94398
24	0.61010	84	1.49178	144	0.88167
27	0.68098	87	1.49794	147	0.81695
30	0.75000	90	1.50000	150	0.75000
33	0.81695	93	1.49794	153	0.68098
36	0.88167	96	1.49178	156	0.61010
39	0.94398	99	1.48153	159	0.53755
42	1.00369	102	1.46722	162	0.46352
45	1.06066	105	1.44888	165	0.38822
48	1.11471	108	1.42658	168	0.31186
51	1.16571	111	1.40037	171	0.23465
54	1.21352	114	1.37031	174	0.15679
57	1.25800	117	1.33650	177	0.07850

TABLE B

```

1000 REM ***** REM
1010 REM ***** DEPTH OF CUT COMPUTER CODE ***** REM
1020 REM ***** REM
1030 DEFFN '00 "LISTS": SELECT PRINT 005: SELECT D : SELECT LIST 005
1040 DIM H1(61,5) ,A(4)
1050 DATA 0, .15, .25, .50: REM (R2 PICK RADIUS)-(R1 PICK) , INCHES
1060 PRINT HEX(03); REM CLEAR CRT SCREEN
1070 INPUT "INPUT THE PICK OFFSET ANGLE, DEGREES ", A0
1080 INPUT "INPUT THE LEADING PICK RADIUS, INCHES", R1
1090 INPUT "INPUT DRUM ROTATION RATE, RPM", N
1100 INPUT "INPUT DRUM TRANSLATION SPEED, IN/SEC", V
1110 U3=60: W3=3
1120 GOTO 9010
2000 REM ***** REM
2010 DEFFN '12: REM FIND SIXTY DEPTHS OF CUT IN INCHES SUBROUTINE
2020 REM ***** REM
2030 MAT H1=ZER
2040 FOR J=1 TO W3+1
2050 READ R : R2=R1+R
2060 FOR I=1 TO U3+1
2070 H1(I,J)=(R2-R1)+(SIN((I-1)*3)*V*60*A0/2/#PI/N/57.29577951)
2080 NEXT I
2090 NEXT J
2100 RETURN
3000 REM ***** REM
3010 DEFFN '15 : REM PRINT CALCULATIONS SUBROUTINE ***** REM
3020 REM ***** REM
3030 PRINT HEX(03)
3040 PRINT
3050 PRINT "TEST CONDITIONS": PRINT
3060 PRINT "OFFSET (DEG) =", A0
3070 PRINT "PICK R1 (IN) =", R1
3080 PRINT "PICK R2 (IN) =", R2
3090 PRINT "R2-R1 (IN) =", R2-R1
3100 PRINT "VELOCITY (IN/S)=", V
3110 PRINT "ROT. SPD. (RPM) =", N
3120 PRINT
3130 PRINT " ANGLE DEPTH ANGLE DEPTH ANGLE DEP
TH"
3140 PRINT " (DEG) (INS) (DEG) (INS) (DEG) (IN
S)": PRINT
3150 FOR I=1 TO 20
3160 PRINT USING 3170, 3*(I-1), H1(I,J), 3*(I-1)+60, H1(I+20,J), 3*(I-
1)+120, H1(I+40,J)
3170 %-### ##.#### -### ##.#### -### ##.####
3180 NEXT I
3190 PRINT : PRINT : PRINT : PRINT
3200 STOP
3210 RETURN

```

```
4000 REM ***** REM
4010 REM ***** PLOT RESULTS SUBROUTINE ***** REM
4020 REM ***** REM
4030 DEFFN '05:SELECT PRINT 005:PRINT HEX(03), "PLOTING RESULTS"
4040 PRINT "INPUT THE FOLLOWING"
4050 PLOT < , ,R>,<100,100,U>
4060 PRINT "X-MIN      X-MAX      Y-MIN      Y-MAX"
4070 FOR I=1 TO 4
4080 INPUT A(I)
4090 PRINT HEX(0C)
4100 FOR J=1 TO I:PRINT HEX(090909090909090909090909):NEXT J
4110 NEXT I
4120 Y1=900*H1(1,1)/(A(4)-A(3))
4130 X1=900/U3
4140 PLOT < ,Y1,U>
4150 FOR J=1 TO W3+1
4160 FOR I=2 TO U3+1
4170 Y=(H1(I,J)-H1(I-1,J))*900/(A(4)-A(3))
4180 PLOT <X1,Y,D>
4190 NEXT I
- 4200 PLOT < , ,R>,<100,100,U>
4210 Y1=900*H1(1,J+1)/(A(4)-A(3))
4220 PLOT < ,Y1,U>
4230 NEXT J:PLOT < , ,R>
4240 RETURN
9000 REM ***** REM
9010 PRINT HEX(03) :REM START PROGRAM ***** REM
9020 REM ***** REM
9030 GOSUB '12 :REM FIND DEPTHS OF CUT ROUTINE
9040 GOSUB '15 :REM PRINT CALCULATIONS ROUTINE
9050 GOSUB '05 :END :REM PLOT RESULTS ROUTINE
9060 REM ***** REM
```