

**NASA TECHNICAL
MEMORANDUM**

NASA TM X-73673

NASA TM X-73673

(NASA-TM-X-73673) LUBRICATION OF
HIGH-SPEED, LARGE BORE TAPERED-ROLLER
BEARINGS (NASA) 29 p HC A03/MF A01 CSCL 11I

N77-33517

**G3/37 Unclass
49486**

**LUBRICATION OF HIGH-SPEED, LARGE
BORE TAPERED-ROLLER BEARINGS**

by R. J. Parker and H. R. Signer
Lewis Research Center
Cleveland, Ohio 44135

**TECHNICAL PAPER to be presented at the
Joint Lubrication Conference
cosponsored by the American Society of Lubrication Engineers
and the American Society of Mechanical Engineers
Kansas City, Missouri, October 3-5, 1977**

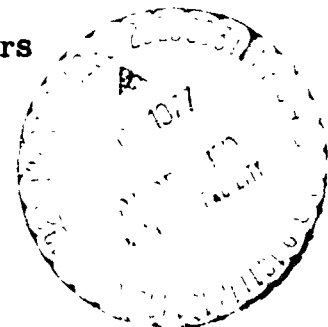

LUBRICATION OF HIGH-SPEED, LARGE BORE
TAPERED-ROLLER BEARINGS

by R. J. Parker* and H. R. Signer**

ABSTRACT

E-8825

The performance of 120.65-mm- (4.75-in. -) bore tapered-roller bearings was investigated at shaft speeds up to 15,000 rpm (1.81×10^6 DN). Temperature distribution and bearing heat generation were determined as a function of shaft speed, radial and thrust loads, lubricant flow rate, and lubricant inlet temperature. Lubricant was supplied either by jets or by a combination of holes through the cone directly to the cone-rib contact and jets at the roller small-end side. Cone-rib lubrication significantly improved high-speed tapered-roller bearing performance, yielding lower cone-face temperatures and lower power loss and allowing lower lubricant flow rates for a given speed condition. Bearing temperatures increased with increased shaft speed and decreased with increased lubricant flow rate. Bearing power loss increased with increased shaft speed and increased lubricant flow rate.

INTRODUCTION

Tapered-roller bearings are being used in some helicopter transmissions to carry combined radial, thrust and moment loads and in particular, those loads from bevel gears such as high-speed input pinions. For this application, tapered-roller bearings have greater

*NASA, Lewis Research Center, Cleveland, Ohio; Member ASME.

**Industrial Tectonics, Inc., Compton, California.

load capacity for a given envelope or for a given bearing weight than the more commonly used ball and cylindrical roller bearings. Speed limitations have restricted the use of tapered-roller bearings to lower speed applications relative to ball and cylindrical roller bearings. The speed limitation is primarily due to the cone-rib/roller-end contact which requires very careful lubrication and cooling consideration at high speeds. The speed of tapered-roller bearings is limited to that which results in a DN value of approximately 0.5 million (a cone-rib tangential velocity of approximately 36 m/sec (7000 ft/min) unless special attention is given to lubricating and designing this cone rib/roller-end contact. At higher speeds, centrifugal effects starve this critical contact of lubricant.

Several means of supplying lubricant directly to this cone-rib contact were investigated at higher speeds in [1]¹. Results of the work in [1] indicate the most successful means was to supply lubricant to the cone-rib contact through holes from the bore of the cone. Additionally, the radius of the spherical large end of the roller was optimized at 75 to 80 percent of the apex length. Development of a large, high-speed tapered-roller bearing for a heavy-lift helicopter transmission was reported in [2]. The feasibility of tapered-roller bearings for the high speed and nearly pure thrust load conditions of turbine engine main-shaft bearings was reported for large and small bores in [3] and [4], respectively.

The use of computer programs can increase the capability of designing and analyzing tapered-roller bearings for such high-speed appli-

¹Numbers in brackets designate References at end of paper.

cations. These programs, described in [5 and 6], take into account the difficulty of lubricating the contacts in high-speed tapered-roller bearings and consider the effects of the elastohydrodynamic (EHD) films in these contacts. The effects of the EHD films in tapered-roller bearing contacts are discussed in [7]. Experimental data at higher speeds are needed to verify the predictions of these computer programs.

The research reported herein was undertaken to investigate the performance of 120.65-mm - (4.75 in. -) bore tapered-roller bearings at speeds up to 15,000 rpm ($1.81 \cdot 10^6$ DN). The maximum cone-rib tangential velocity at this speed was 130 m/sec (25,500 ft/min). The objective of this program was to determine the operating characteristics, including temperature distribution and heat generation, of this bearing as a function of shaft speed, radial and thrust load, lubricant flow rate, and lubricant inlet temperature. Lubrication was applied either by jets or by a combination of holes through the cone directly to the cone-rib contact and jets at the roller small-end side. Test conditions included shaft speeds of 6000, 10,000, 12,500, and 15,000 rpm, radial loads of 13,300 to 26,700 N (3000 to 6000 lb), thrust loads of 26,700 to 53,400 N (6000 to 12,000 lb), lubricant flow rates from 1.9×10^{-3} to 15.1×10^{-3} m³/min (0.5 to 4.0 gpm); and lubricant-in temperatures of 350 and 364 K (170^o and 195^o F).

APPARATUS AND PROCEDURE

High-Speed Tapered Roller Bearing Test Rig

One of two test bearings mounted on a spindle is shown in Fig. 1. The cup of each test bearing is mounted in a test head assembly. The right test head assembly is mounted rigidly to the machine frame;

whereas the left test head assembly is axially movable and is supported on ball and roller ways. This arrangement allows thrust loading of the test bearings with a pair of hydraulic actuators. Radial load is applied to the test bearings by a hydraulic actuator that exerts a force on a center housing containing two cylindrical roller support bearings mounted near the center of the spindle.

A flat-belt-pulley system is used to drive the spindle from an electric motor. The desired spindle speeds are chosen by exchanging drive pulleys on the motor. The test spindle is hollow and contains contoured inserts with annular grooves to distribute lubricant to radial holes for cone-rib lubrication of the test bearing (fig. 2) and for lubrication of the load bearing. A stationary lubrication tube delivers the desired lubricant flow to the annular grooves. For jet lubrication of the test bearings, two supply tubes are located 180 degrees apart at the roller small end of each test bearing.

The lubrication system contains separately controlled circuits for cone-rib lubrication, jet lubrication, cup (outer ring) cooling, and support bearing lubrication. The lubricant flow through each circuit is metered with a variable flow control valve. A 10 micron filter and an oil-water heat exchanger are common to all the separate circuits.

Thermocouples are installed for temperature measurements of each test bearing cup outer surface, each cylindrical load bearing outer ring, and oil inlet and outlet temperatures of both test and load bearings. Temperatures of the cone bore and cone face of the test bearing (fig. 2) on the drive end of the test spindle were measured with thermo-

couples and either a slip-ring system or an FM telemetry system. A more detailed description of this test rig is given in [8].

Test Bearings

The tapered-roller test bearings had a bore of 120.6 mm (4.75 in.) and an outside diameter of 206.4 mm (8.125 in.). The cup angle was 34° , and the roller included angle was $3^{\circ} 10'$. The bearing contained 25 rollers with a large end diameter of 18.29 mm (0.720 in.) and an overall length of 34.17 mm (1.3452 in.). The rollers were fully crowned with a crown radius of 25.4×10^3 mm (1000 in.) and had a spherical end radius equal to 80 percent of the apex length.

The material of the cup, cone, and rollers was case-carburized consumable-electrode vacuum-melted AISI 4320 steel. The one piece, roller-riding cage was silver plated AISI 1010 steel. The hardnesses, case depth, and surface finish specifications are shown in Table 1.

The cone contained forty oil holes, 1.016 mm (0.040 in.) in diameter, drilled through from a manifold on the cone bore to the undercut at the large end of the cone, as shown in Fig. 2.

The basic dynamic load ratings for this bearing are 74,700 N (16,800 lb) radial load and 58,700 N (13,200 lb) thrust load. (The thrust or radial load which gives 10 percent life of 90 million cone revolutions.) The AFBMA basic dynamic capacity is 288,000 N (64,800 lb).

Procedure

The test procedure was adjusted according to the test conditions to be evaluated. Generally, a program cycle was defined which would allow the evaluation of a number of conditions without a major inter-

ruption. Test parameters such as load, speed, and oil inlet temperature were maintained constant while the tester was in operation. Lubricant flow rates were adjusted during operation. The test bearings were allowed to reach an equilibrium condition before data were recorded and the next test condition was sought.

RESULTS AND DISCUSSION

Effect of Lubricant Flow on Bearing Temperatures

The effect of lubricant flow rate either through jets (jet lubrication) or through holes in the cone (cone-rib lubrication), was determined for a variety of speeds, loads, and oil-in temperatures. Temperatures of the 120.65 mm (4.75-in. -) bore tapered-roller test bearing at the drive end of the test spindle were measured on the cone bore and the cone face as well as on the outer surface of the cup. Oil-out temperature was also measured. Test spindle speeds were 6000, 10,000, 12,500, and 15,000 rpm. Thrust load was varied from 26,700 to 53,400 N (6000 to 12,000 lb). Radial load was varied from 13,300 to 26,700 N (3000 to 6000 lb). Lubricant flow rate was varied from 1.9×10^{-3} to 15.1×10^{-3} m³/min (0.5 to 4.0 gpm). When cone-rib lubrication was used a constant 3.8×10^{-3} m³/min (1.0 gpm) of jet flow was also used to assure some lubrication of the roller small end. The lubricant was a 5-centistoke neopentylpolyol (tetra) ester. This type II oil is qualified to MIL-L-23699 as well as to the internal oil specifications of most major aircraft turbine engine manufacturers.

Test bearing temperatures and oil-out temperatures, measured at these test conditions, are shown in Figs. 3 to 6. Fig. 3 shows very little effect of thrust load on cone face temperature. The effects of

radial load were even less. This data is typical throughout the range of data taken. That is, regardless of speed, oil-in temperatures, or flow rates, load had little effect on bearing or oil-out temperatures. Therefore, the data shown in Figs. 4 to 6 are for only one load condition, that is, 53,400 N (12,000 lb) thrust load and 26,700 N (6000 lb) radial load.

Figure 4 shows the general decrease in bearing and oil-out temperatures with increased flow rate at a shaft speed of 6000 rpm and an oil-in temperature of 350 K (170° F) for both jet and cone-rib lubrication. With jet lubrication (fig. 4(a)), temperatures are decreased by approximately 28 K (50° F) as flows are increased from 1.9×10^{-3} to 7.6×10^{-3} m³/min (0.5 to 2.0 gpm). At higher flow rates, the rate of temperature decrease diminishes.

Similar effects are seen in Fig. 4(b) for cone-rib lubrication, where the total flow rate includes 3.8×10^{-3} m³/min (1.0 gpm) of lubricant through jets at the roller small end of the bearing. Thus, the data points at 3.8×10^{-3} m³/min (1.0 gpm) are for zero cone-rib flow rate.

Figure 5 shows flow rate effects on bearing and oil-out temperatures at a shaft speed of 10,000 rpm at an oil-in temperature of 350 K (170° F). The trends are similar to the 6000-rpm data. Data at jet flow rates below 7.6×10^{-3} m³/min (2.0 gpm) were not obtained, since the first test at a jet flow rate of 3.8×10^{-3} m³/min (1.0 gpm) resulted in surface distress of the cone rib on one of the test bearings prior to reaching equilibrium. The test bearing on which the cone-face and cone-bore temperatures were measured was not damaged. Further

tests at this flow rate and below were not run, including those at the higher oil-in temperature.

Extrapolation of the cone-face temperature in Fig. 5(a) to a flow rate of $3.8 \times 10^{-3} \text{ m}^3/\text{min}$ (1.0 gpm) shows that a temperature in excess of 433 K (320^o F) could have existed. The temperature of the cone-rib contact with the roller large end would undoubtedly be even higher. Considering the severity of this rolling/sliding contact and the temperature limitations of the AISI 4320 material of the cone and rollers, the occurrence of surface damage at this condition is not surprising.

Data for cone-rib flow rates as low as $1.9 \times 10^{-3} \text{ m}^3/\text{min}$ (0.5 gpm) (total flow rate of $5.7 \times 10^{-3} \text{ m}^3/\text{min}$ (1.5 gpm)) were obtained at 10,000 rpm. Maximum cone-face temperatures at this flow rate were only 395 K (252^o F) at an oil-in temperature of 350 K (170^o F) (fig. 5(b)).

Data at an oil-in temperature of 364 K (195^o F) at both 6000 and 10,000 rpm shows identical trends with increased flow rate as those shown in Figs. 4 and 5. Further discussion on the effects of oil-in temperature is presented in a later section.

The effects of flow rate at a shaft speed of 15,000 rpm are shown in Fig. 6. Only one test condition was run at 15,000 rpm with jet flow. Those data, at $15.1 \times 10^{-3} \text{ m}^3/\text{min}$ (4.0 gpm), are shown as the solid data points in Fig. 6(a). It was anticipated that lower jet flow rates at this shaft speed may allow excessive cone-rib temperatures and cause subsequent surface distress.

Data were obtained for all desired flow rate conditions with cone-rib flow at 350 K (170^o F) oil-in temperature (fig. 6(a)). Data at an oil-in temperature of 364 K (195^o F), Fig. 6(b), were not obtained for

total flow rates less than $7.6 \times 10^{-3} \text{ m}^3/\text{min}$ (2.0 gpm) due to temperature limitations. (Data shown at $7.6 \times 10^{-3} \text{ m}^3/\text{min}$ (2.0 gpm) was obtained at 20,000 N (4500 lb) radial load.)

An increased effect of flow rate on oil-out temperature is seen at this higher shaft speed of 15,000 rpm, whereas the flow rate effect on bearing temperatures at the higher speed is not significantly different from that at the lower speeds.

In general, the effects on bearing temperatures of flow rates above $11.4 \times 10^{-3} \text{ m}^3/\text{min}$ (3.0 gpm) are small. The use of flow rates greater than this for these bearings at these conditions does not appear to be warranted, especially where cone-rib lubrication is used. Additionally, as will be shown later, bearing power loss increases as lubricant flow rates are increased.

Effects of Shaft Speed and Cone-Rib Lubrication

The effect of shaft speed on cone-face temperature is shown in Fig. 7 for an oil-in temperature of 350 K (170° F). Increasing the shaft speed from 6000 to 15,000 rpm increases cone-face temperature by as much as 49 K (89° F). Shaft speed has a lesser effect on cone-face temperature where cone-rib lubrication is used rather than jet lubrication. It is apparent that extrapolation of the data in Fig. 7(a) to 15,000 rpm for jet flow rates less than $7.6 \times 10^{-3} \text{ m}^3/\text{min}$ (2.0 gpm) at 350 K (170° F) oil-in temperature would give cone-face temperatures in excess of 430 K (320° F). For lubrication through the cone-rib (with $3.3 \times 10^{-3} \text{ m}^3/\text{min}$ (1.0 gpm) jet flow), satisfactory cone-face temperatures were obtained at 15,000 rpm with total flow rates as low as $5.7 \times 10^{-3} \text{ m}^3/\text{min}$ (1.5 gpm) (fig. 7(b)).

The advantage of cone-rib lubrication is further illustrated in Fig. 8. The difference in the temperature of the cone-face with jet lubrication and that with cone-rib lubrication increases with shaft speed. At 15,000 rpm, the difference is 34 K (62° F). Even at the lower speed of 6000 rpm, the temperature improvement is an average of approximately 13 K (23° F).

It can be observed from Figs. 4 to 6, that when cone-rib lubrication is used, the highest bearing temperature measured at each condition is at the cup outer surface. When jet lubrication alone is used, the highest measured temperatures were on the cone face. This effect is illustrated in Fig. 9 where the temperatures are plotted against shaft speed for an oil-in temperature of 364 K (195° F) and a total oil flow of $11.4 \times 10^{-3} \text{ m}^3/\text{min}$ (3.0 gpm). Cone-bore and oil-out temperatures for jet lubrication and for cone-rib lubrication are not significantly different.

It is believed that when cone-rib lubrication is used, less oil is thrown centrifugally outward to cool the cup before it leaves the bearing. Also, the oil that is directed through the cone-rib and does contact the cup, has been heated somewhat in cooling the cone rib. Thus, a somewhat greater cup temperature has accompanied a cooler cone rib, but because of the critical nature of the cone-rib contact in high-speed tapered roller bearings, this small sacrifice appears justified.

The higher cup temperatures may be decreased with the use of cup cooling oil flowing in the cup housing in contact with the outer surface of the cup. Figure 10 includes some additional temperature data obtained at a shaft speed of 12,500 rpm and $5.7 \times 10^{-3} \text{ m}^3/\text{min}$

(1.5 gpm) total oil flow (cone-rib flow of $1.9 \times 10^{-3} \text{ m}^3/\text{min}$ (0.5 gpm) plus jet flow of $3.8 \times 10^{-3} \text{ m}^3/\text{min}$ (1.0 gpm). With the addition of $2.6 \times 10^{-3} \text{ m}^3/\text{min}$ (0.7 gpm) cup cooling flow (solid symbols in Fig. 10), the cup outer surface temperature is decreased 14 K (25° F) without significant change in cone-face and cone-bore temperatures. Oil-out temperature was 6 K (11° F) lower due to the quantity of heat removed by the 364 K (195° F) cup cooling oil which was measured at 380 K (225° F) upon exit from the cooling passages.

Effect of Oil-In Temperature

The effect of oil-in temperature on cone-face and cup outer surface temperatures at a shaft speed of 10,000 rpm is shown in Fig. 11. At an oil-in temperature of 364 K (195° F), the cup outer surface and cone-face temperatures are from 7 to 10 K (12° to 18° F) higher than for an oil-in temperature of 350 K (170° F) for both jet lubrication and for cone-rib lubrication. This effect was similar for shaft speeds of 6000 and 15,000 rpm and for the cone-bore and oil-out temperatures. In general, the net change in bearing temperatures is on the order of 50 to 75 percent of the change in oil-in temperature.

Effect of Speed and Lubricant Flow on Bearing Power Loss

The power loss from the bearing is dissipated in the form of heat by conduction to the lubricant and by conduction, convection, and radiation to the surrounding environment. Lubricant outlet temperature from the bearing was measured for all conditions of flow. Heat transferred to the lubricant was calculated using the standard heat transfer equation

$$Q_T = MC_P(t_{\text{out}} - t_{\text{in}}) \quad (1)$$

where

Q_T total heat transfer to lubricant, J/min (Btu/min)

M lubricant mass flow, kg/min (lb/min)

C_P specific heat, J/(kg)(K) (Btu/(lb)(°F))

t_{out} oil outlet temperature, K (°F)

t_{in} oil inlet temperature, K (°F)

The result of these heat transfer calculations are shown in Fig. 12 as a function of shaft speed and total flow rate. (For convenience, heat values were converted from J/min to kW.) The heat transferred to the lubricant increases with both increased shaft speed and increased lubricant flow rate. These increases are expected due to increased lubricant drag or churning. These heat quantities are a portion of the heat generated in the test bearings and do not include heat transferred from the bearing by conduction, convection, and radiation. At higher bearing temperatures, the heat transferred by these latter forms should become a greater portion of the total.

An equation for calculating operating torque of tapered-roller bearings has been developed by Witte [9]. The equation is based on a dimensional analysis of the operating and geometric variables involved. Experimental data are used to obtain exponents and constants. The equation for combined radial and thrust loads on tapered-roller bearings as published in [9] is

$$M = AG(S\mu)^{1/2} \left(\frac{f_T F_r}{K} \right)^{1/3} \quad (2)$$

where

M	total bearing torque, N-m (lb-in.)
A	constant determined from test data of [9]
G	bearing geometry factor given in [9]
S	shaft speed, rpm
μ	lubricant absolute viscosity at atmospheric pressure, cP
F_R	bearing radial load, N (lb)
K	bearing K factor = ratio of basic dynamic radial load rating to basic dynamic thrust load rating
f_T	equivalent thrust load factor given as a function of ratio of thrust-to-radial load in [9]

Operating torque for the test bearing used in this program was calculated using this equation and converted to power loss for comparison with the heat transfer data. This comparison is shown in Table 2. At the lower speeds the calculated bearing power loss and the heat transferred to the lubricant are very similar in magnitude. At the higher speeds, the heat transferred to the lubricant is less than the calculated power loss. This effect may be expected since at higher speeds, and thus higher temperatures, losses due to convection and radiation to the surrounding environment would be greater. The agreement at lower speeds is reasonable, although the power loss equation (Eq. (2)) does not account for effects of lubricant flow rates. Significant increases in heat transferred to the lubricant with increased lubricant flow rate are shown in Fig. 12.

SUMMARY

The performance of 120.65 mm (4.75-in.) bore tapered-roller bearings was investigated at shaft speeds up to 15,000 rpm (cone-rib tangential velocities up to 130 m/sec (25,500 ft/min)). Temperature distribution and bearing heat generation were determined as a function of shaft speed, radial and thrust loads, lubricant flow rate, and lubricant inlet temperature. Lubricant was supplied by either jets or by a combination of holes through the cone directly to the cone-rib contact and jets at the roller small-end side. Test conditions included shaft speeds from 6000 to 15,000 rpm, radial loads from 13,300 to 26,700 N (3000 to 6000 lb), thrust loads from 26,700 to 53,400 N (6000 to 12,000 lb), lubricant flow rates from $1.9 \cdot 10^{-3}$ to $15.1 \cdot 10^{-3}$ m³/min (0.5 to 4.0 gpm), and lubricant inlet temperatures of 350 and 364 K (170° and 195° F).

The following results were obtained:

1. Direct cone-rib lubrication significantly improved tapered-roller bearing performance at high speeds. With cone-rib lubrication, total flow rates as low as $5.7 \cdot 10^{-3}$ m³/min (1.5 gpm) provided stable bearing operation at 15,000 rpm, whereas with jet lubrication alone, a flow rate of $15.1 \cdot 10^{-3}$ m³/min (4.0 gpm) was required. Bearing power loss was less with cone-rib lubrication than with jet lubrication at the same lubricant flow rates.

2. Bearing temperatures and power loss increased with increasing shaft speed.

3. With increased lubricant flow rate, bearing temperatures decreased and bearing power loss increased.

4. Bearing power loss calculated from a published equation for operation torque of tapered-roller bearings showed very good agreement with the portion of bearing power loss as determined experimentally from heat transfer to the lubricant.

5. At 6000 rpm, flow rates as low as $1.9 \times 10^{-3} \text{ m}^3/\text{min}$ (0.5 gpm) provided stable bearing operation for all conditions tested.

6. Increasing oil-in temperature from 350 to 364 K (170° to 195° F) increased bearing temperatures approximately 7 to 10 K (12° to 18° F).

7. The effect of load on bearing temperatures was very small relative to speed and lubricant flow rate effects.

REFERENCES

1. Lemanski, A. J., Lenski, J. W., Jr., and Drago, R. J., "Design, Fabrication, Test, and Evaluation of Spiral Bevel Support Bearings (Tapered Roller)," Boeing Vertol Co., USAAMRDL-TR-73-16, (1973).
2. Lenski, J. W., Jr., "Test Results Report and Design Technology Development Report. HLH/ATC High Speed Tapered Roller Bearing Development Program." T301-10248-1 Boeing Vertol Co., USAAMRDL-TR-74-33, (1974).
3. Cornish, R. F., Orvos, P. S., and Dressler, G. J., "Design Development and Testing of High Speed Tapered Roller Bearings for Turbine Engines," Timken Co., AFAPL-TR-75-26, (1975).
4. Conners, T. F. and Morrison, F. R., "Feasibility of Tapered Roller Bearings for Main-Shaft Engine Applications," SKF-AL73T009, SKF Industries, Inc., USAAMRDL-TR-73-46 (1973).

5. Crecelius, W. J. and Milke, D. R. , "Dynamic and Thermal Analysis of High Speed Tapered Roller Bearings Under Combined Loading," SKF-AL73P010, SKF Industries, Inc. , NASA CR-121207 (1973).
6. Cornish, R. F. , Orvos, P. S. , and Gupta, S. R. , "Development of High Speed Tapered Roller Bearing," IR-1, Timken Roller Bearing Co. , AFAPL-TR-73-85 (1973).
7. Wren, F. J. and Moyer, C. A. , "Understanding Friction and EHL Films in Concentrated Contacts of a Tapered Roller Bearing," Elastohydrodynamic Lubrication: 1972 Symposium, Inst. of Mech. Engrs. , Paper No. C10/72, pp. 55-60.
8. Parker, R. J. and Signer, H. R. , "Performance of Large-Bore Tapered-Roller Bearings Under Combined Radial and Thrust Load at Shaft Speeds to 15,000 rpm," NASA TN D-8404 (1977).
9. Witte, D. C. , "Operating Torque of Tapered Roller Bearings," ASLE Trans. 16, 61 (1973).

TABLE 1. - TEST BEARING SPECIFICATIONS

Cup, cone, and roller material	AISI 4320
Case hardness, Rockwell C	58 to 64
Core hardness, Rockwell C	25 to 48
Case depth (to 0.5 % carbon level after final grind), cm (in.):	
Cup and cone	0.086 to 0.185 (0.034 to 0.073)
Roller	0.091 to 0.201 (0.036 to 0.079)
Surface finish ^a , $\mu\text{m}(\mu\text{in.})$ rms:	
Cone raceway	0.15 (6)
Cup raceway	0.20 (8)
Cone-rib	0.18 (7)
Roller taper	0.13 (5)
Roller spherical	0.15 (6)

^aMeasured values.

TABLE 2. - HEAT TRANSFERRED TO LUBRICANT AND BEARING POWER

LOSS FOR SEVERAL SPEED AND LOAD CONDITIONS

[Total flow rate, 0.0114 m³/min (3.0 gpm); oil-in temperature, 350 K (170° F); lubrication, jet only for 6000 rpm and cone-rib lubrication for 10 000 rpm and above.]

Shaft speed, rpm	Thrust load		Radial load		Heat transferred to lubricant calculated from equation (1)		Bearing power loss calculated from equation (2)	
	N	lb	N	lb	kW	hp	kW	hp
4 000	26 700	6 000	26 700	6000	5.6	7.5	5.5	7.4
6 000	40 000	9 000	26 700	6000	6.2	8.3	7.2	9.6
6 000	53 400	12 000	26 700	6000	6.6	8.9	7.2	9.6
10 000	26 700	6 000	13 300	3000	11.3	15.1	9.8	13.2
10 000	40 000	9 000	26 700	6000	12.4	16.7	12.4	16.7
10 000	53 400	12 000	26 700	6000	13.0	17.5	12.4	16.7
12 500	53 400	12 000	26 700	6000	12.6	^a 16.9	17.9	24.0
15 000	40 000	9 000	8 900	2000	17.2	23.1	22.0	29.5
15 000	53 400	12 000	13 300	3000	19.2	25.8	24.2	32.4
15 000	53 400	12 000	26 700	6000	19.2	25.8	24.2	32.4

^aData for total flow rate of 0.0076 m³/min (2 gpm).

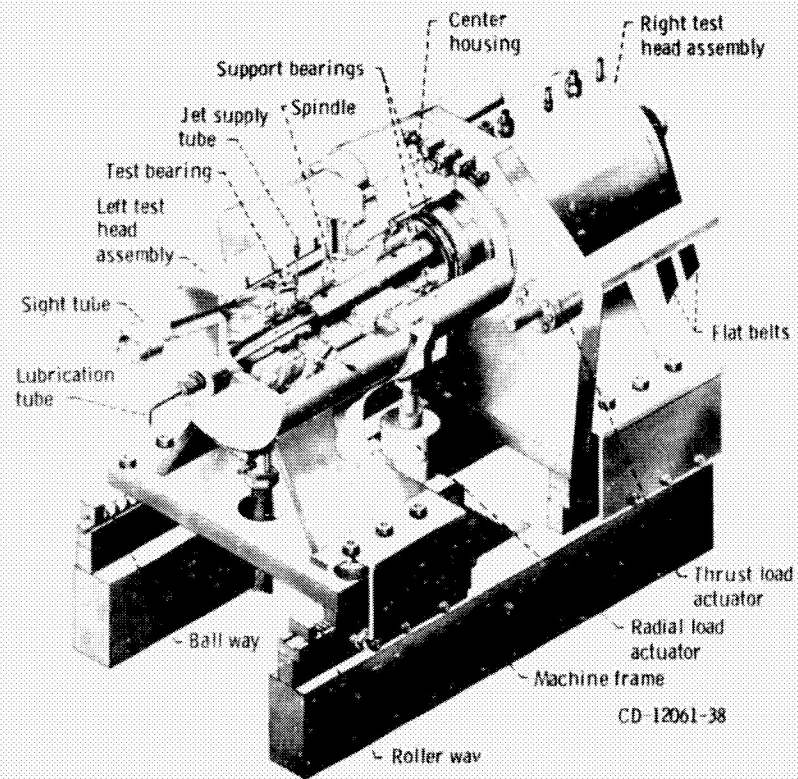

Figure 1. - Pictorial view of high-speed tapered roller bearing test rig.

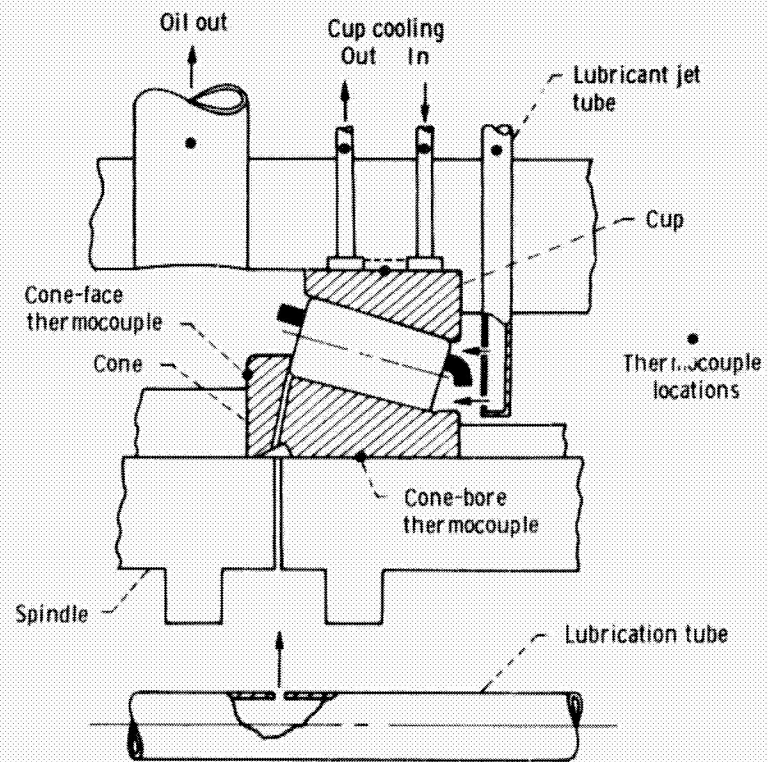

Figure 2. - Test bearing lubrication and thermocouple locations.

ORIGINAL PAGE IS
 OF POOR QUALITY

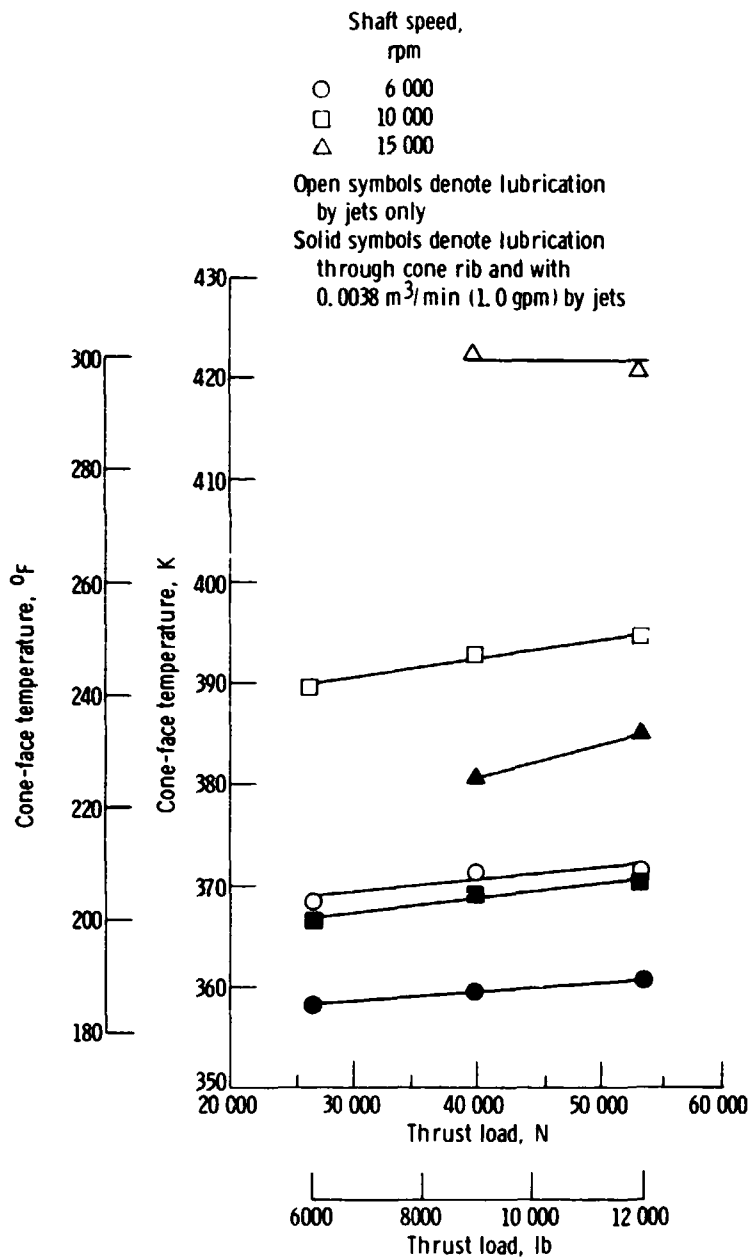

Figure 3. - Effect of thrust load on cone-face temperature. Radial load, 13 400 N (3000 lb); oil-in temperature, 350 K (170° F); total oil flow, $0.0151 \text{ m}^3/\text{min}$ (4.0 gpm).

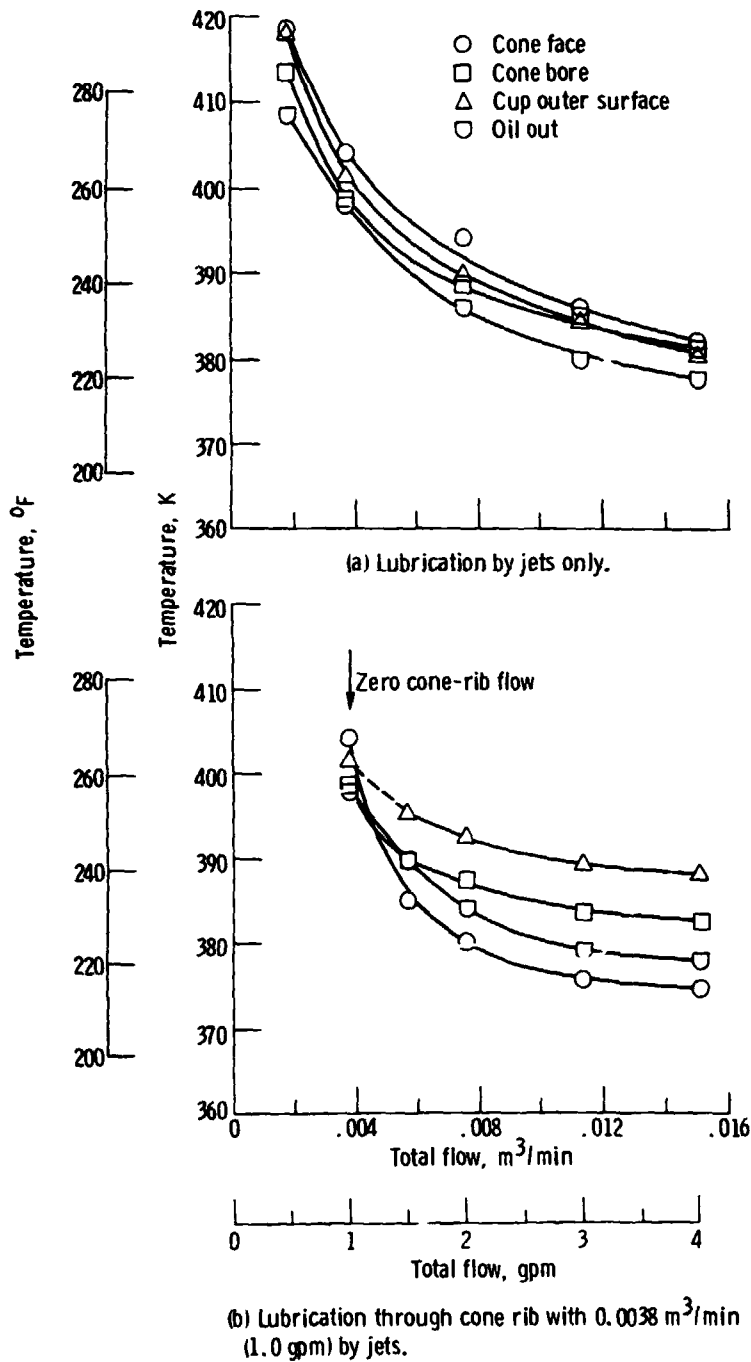

Figure 4. - Temperature as a function of flow rate at shaft speed of 6000 rpm. Thrust load, 53 400 N (12 000 lb); radial load, 26 700 N (6000 lb); oil-in temperature, 364 K (195° F).

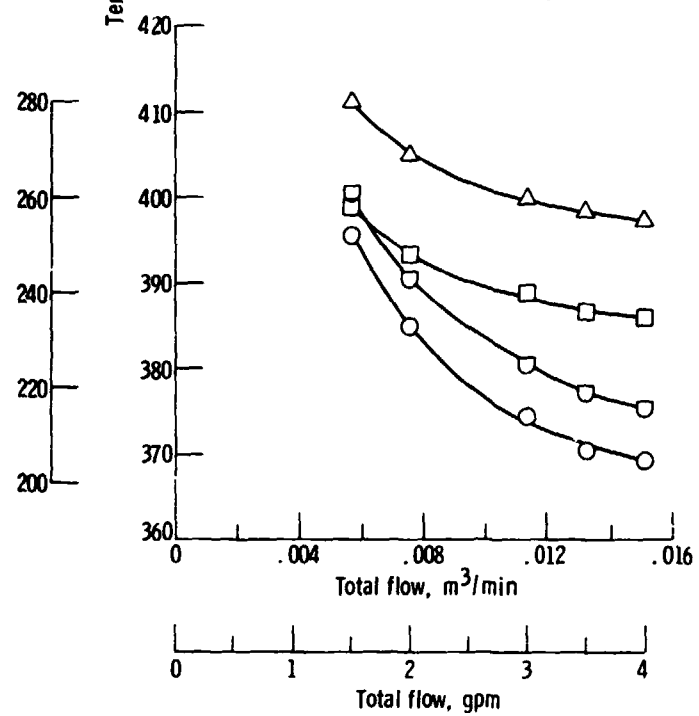
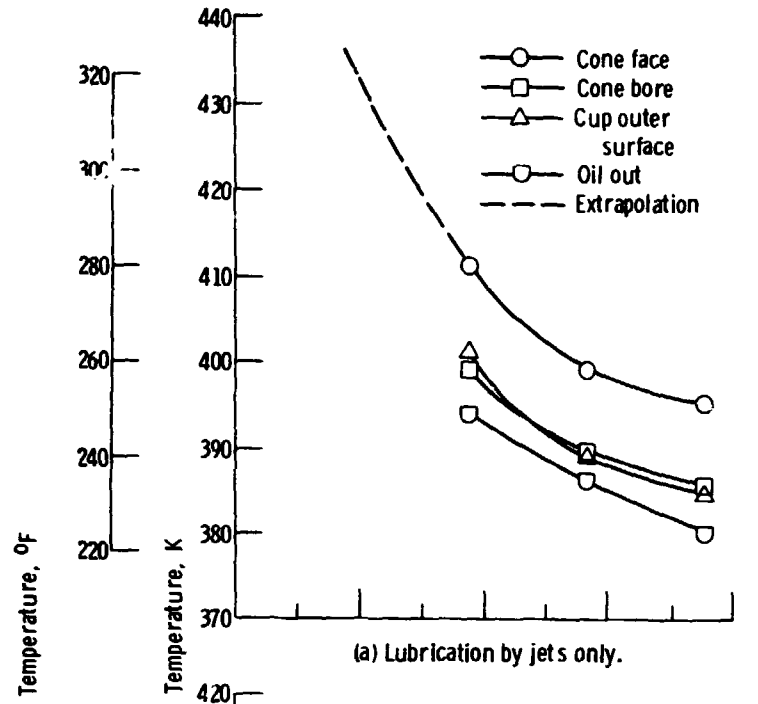

Figure 5. - Temperature as a function of flow rate at a shaft speed of 10 000 rpm. Thrust load, 53 400 N (12 000 lb); radial load, 26 700 N (6000 lb); oil-in temperature, 350 K (170° F).

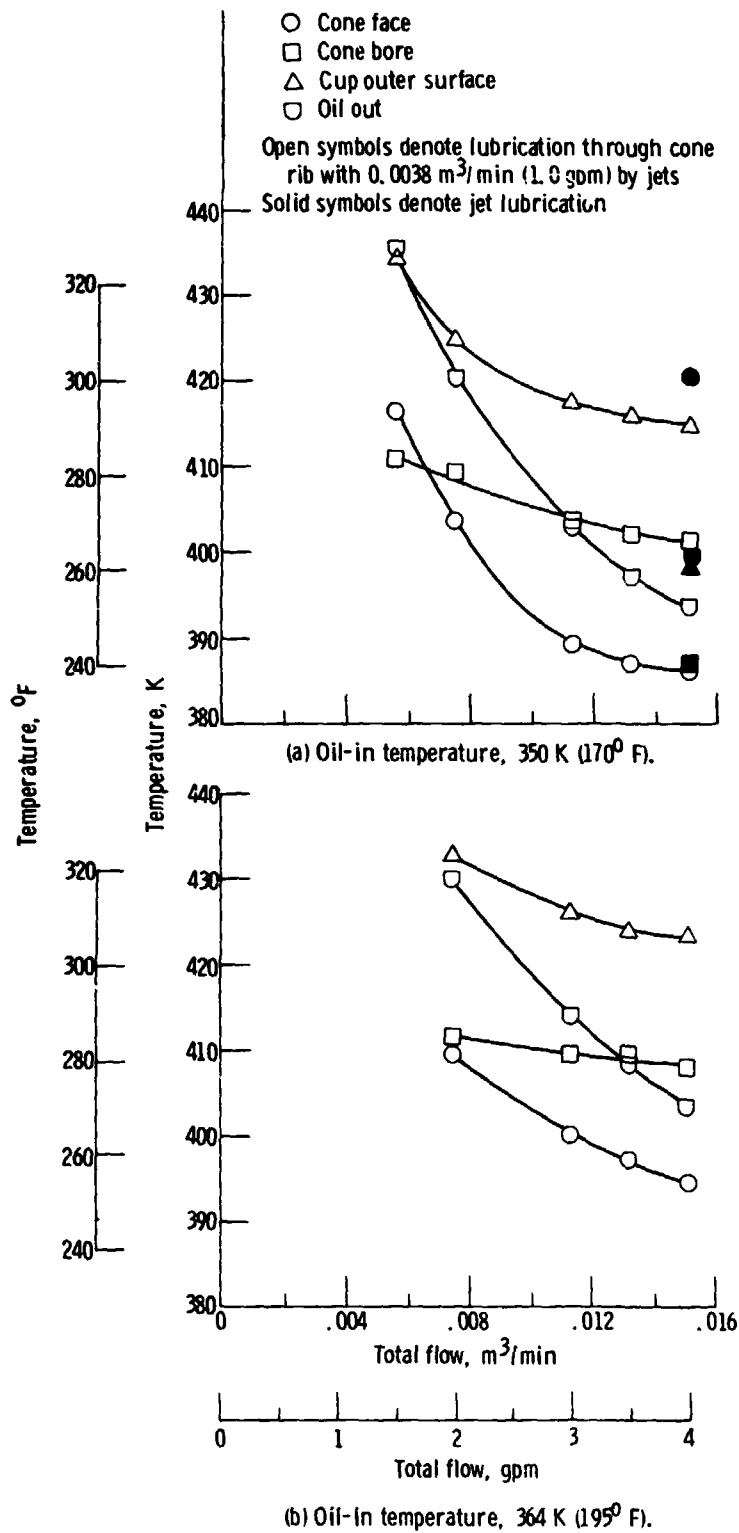

Figure 6. - Temperature as function of flow rate at shaft speed of 15 000 rpm. Thrust load, 53 400 N (12 000 lb); radial load, 26 700 N (6000 lb).

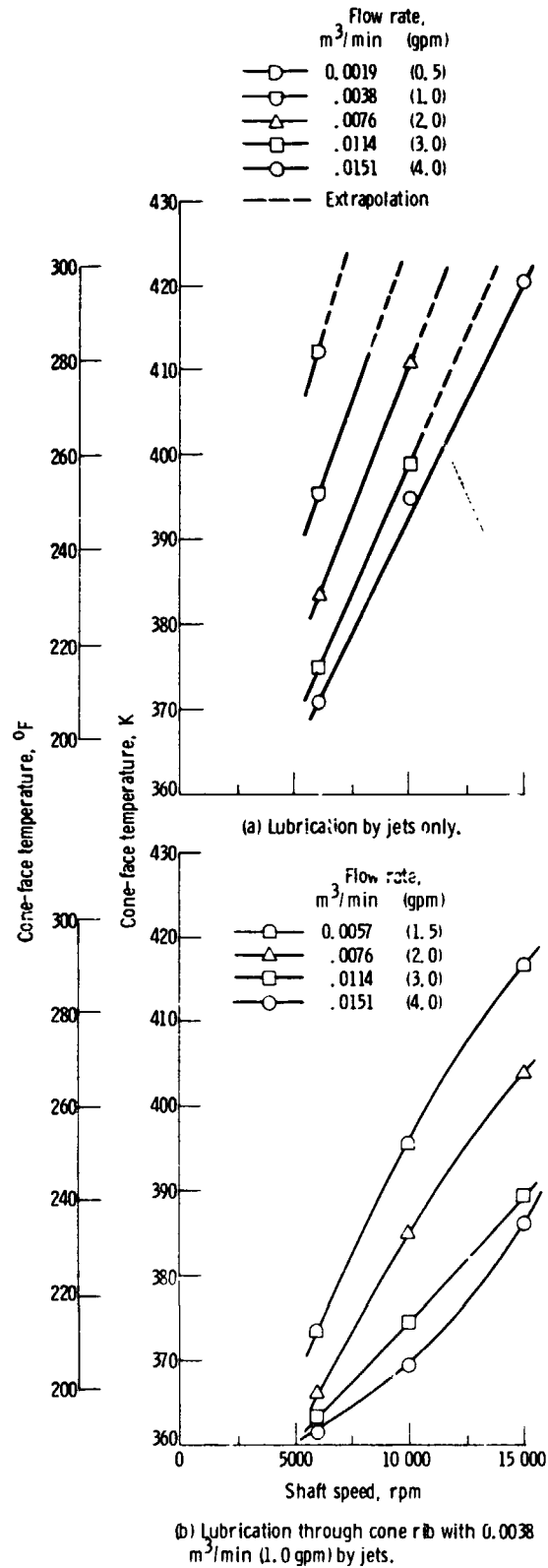

Figure 7. - Effect of shaft speed and flow rate on cone-face temperature for oil-in temperature of 350 K (170° F). Thrust load, 53 400 N (12 000 lb); radial load, 26 700 N (6000 lb).

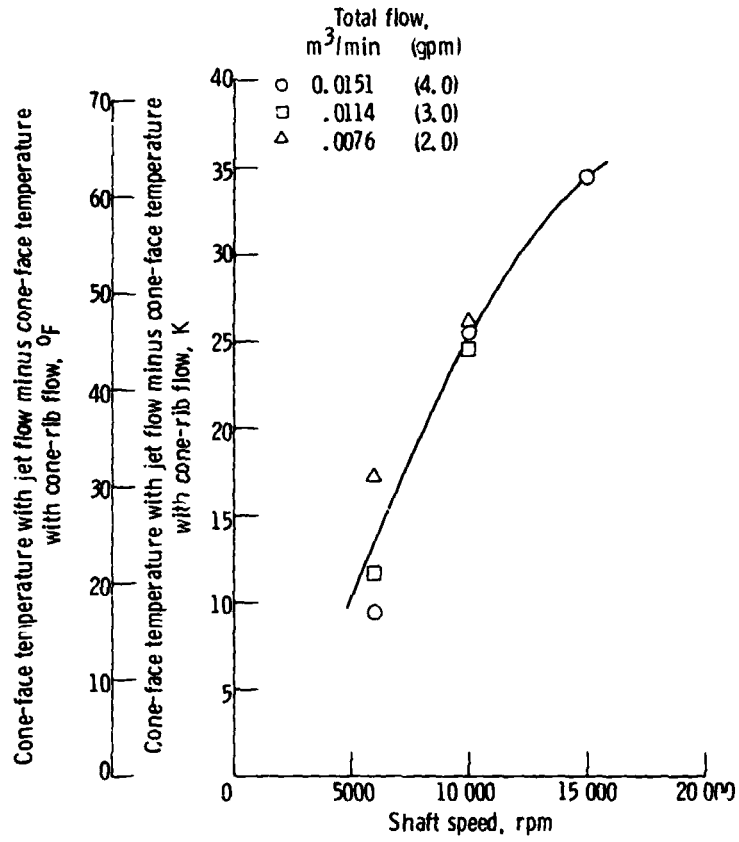

Figure 8. - Effect of shaft speed on cone-face temperature with jet lubrication minus that with cone-rib lubrication. Oil-in temperature, 350 K (170° F); thrust load, 53 400 N (12 000 lb); radial load, 26 700 N (6000 lb).

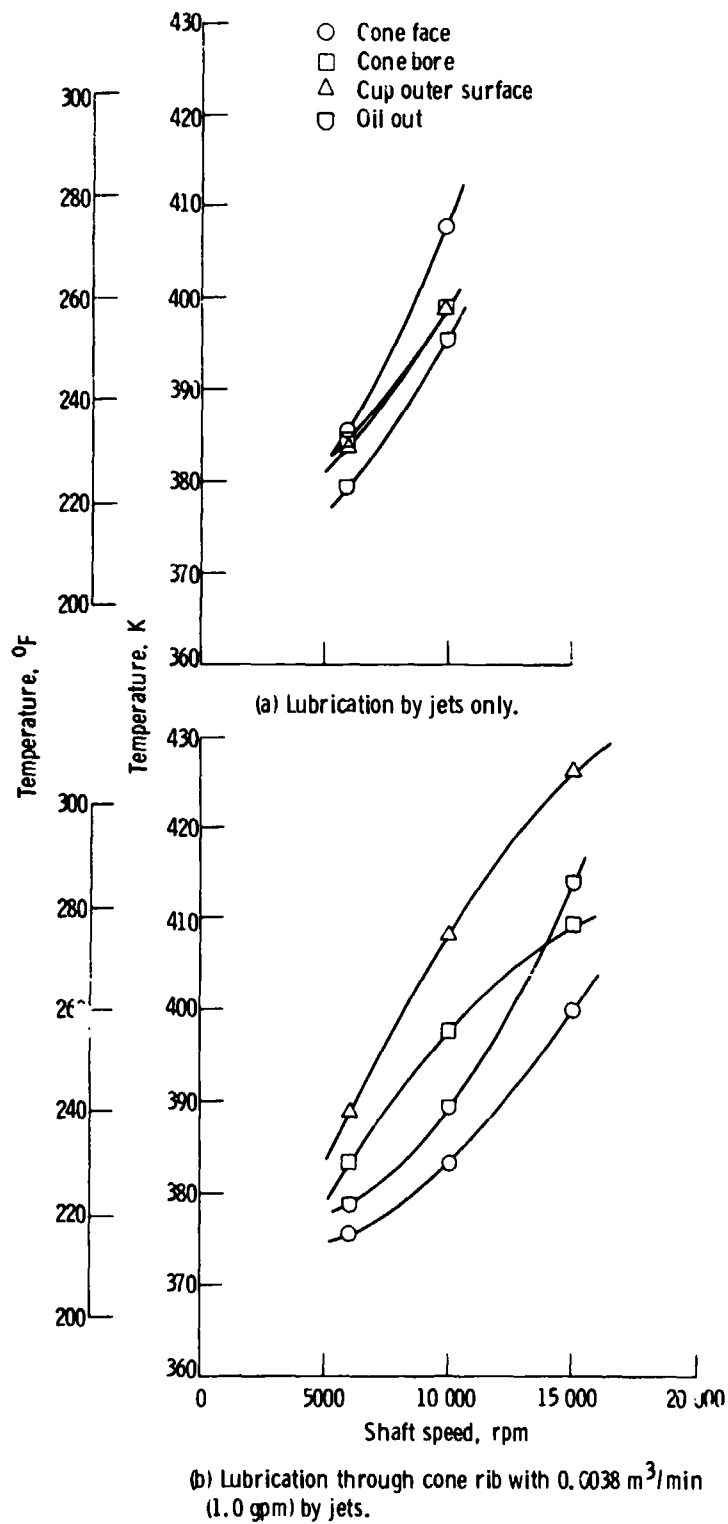

Figure 9. - Effect of jet lubrication and cone-rib lubrication on bearing and oil-out temperatures. Thrust load, 53 400 N (12 000 lb); radial load, 26 700 N (6000 lb); oil-in temperature, 364 K (195° F); total oil flow rate, $0.0114 \text{ m}^3/\text{min}$ (3.0 gpm).

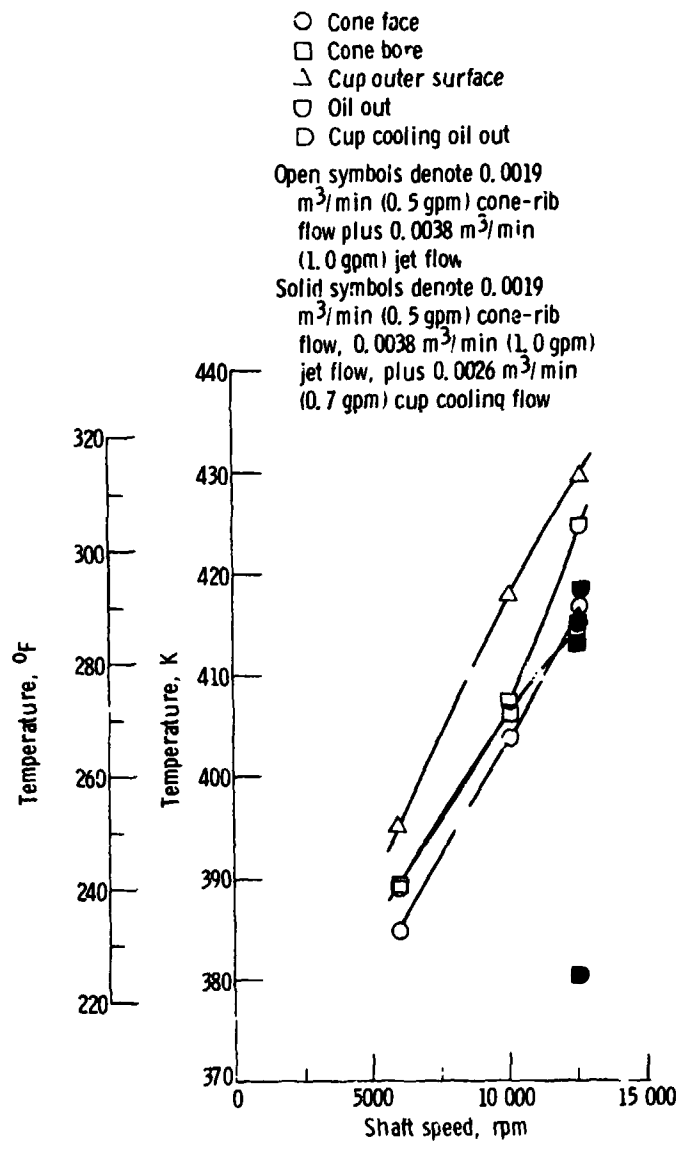

Figure 10. - Effect of cup cooling on bearing and oil-out temperatures. Thrust load, 53 400 N (12 000 lb); radial load, 26 700 N (6000 lb); oil-in temperature, 364 K (192° F).

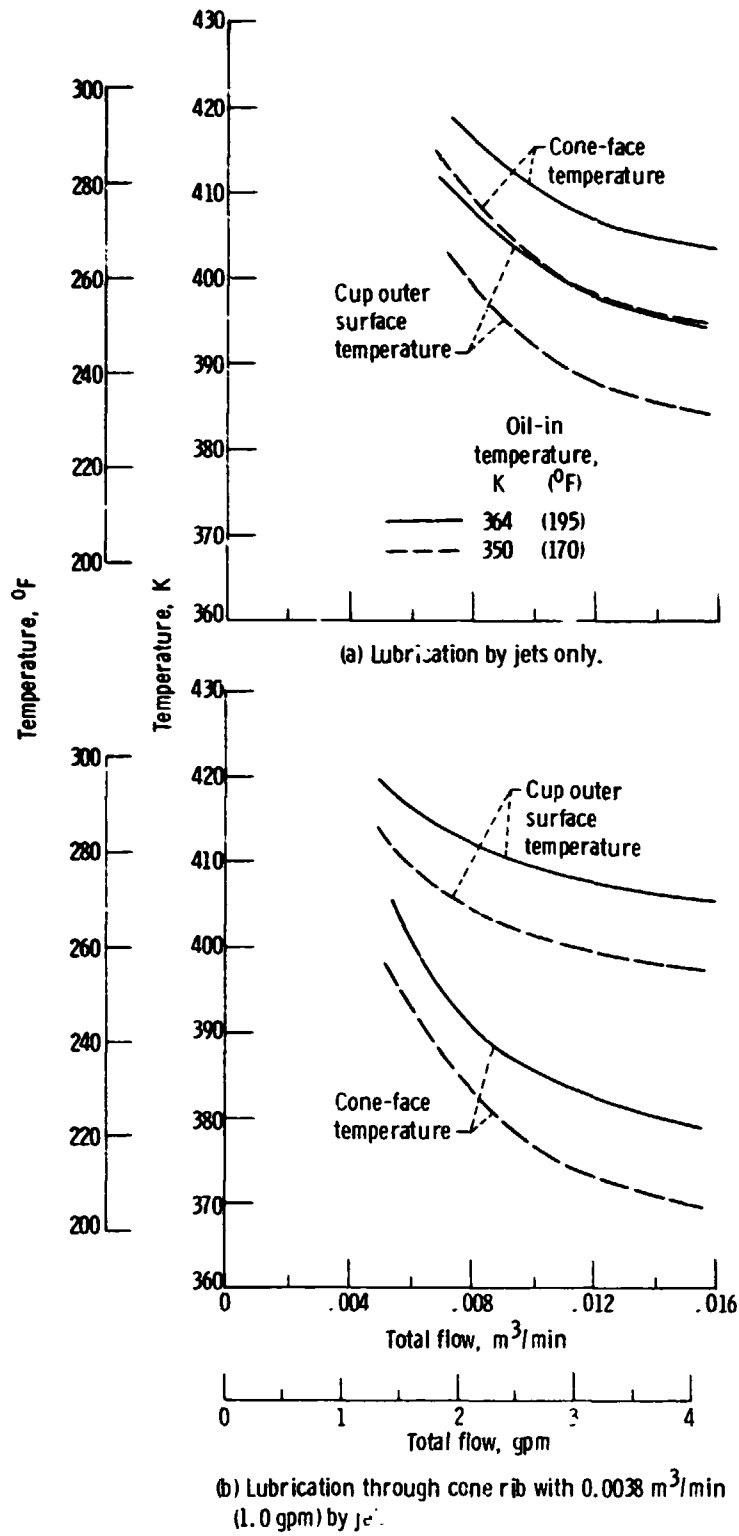

Figure 11. - Effect of oil-in temperature on cone-face and cup outer surface temperatures. Shaft speed, 10 000 rev/min; thrust load, 53 400 N (12 000 lb); radial load, 6 800 N (1 500 lb).

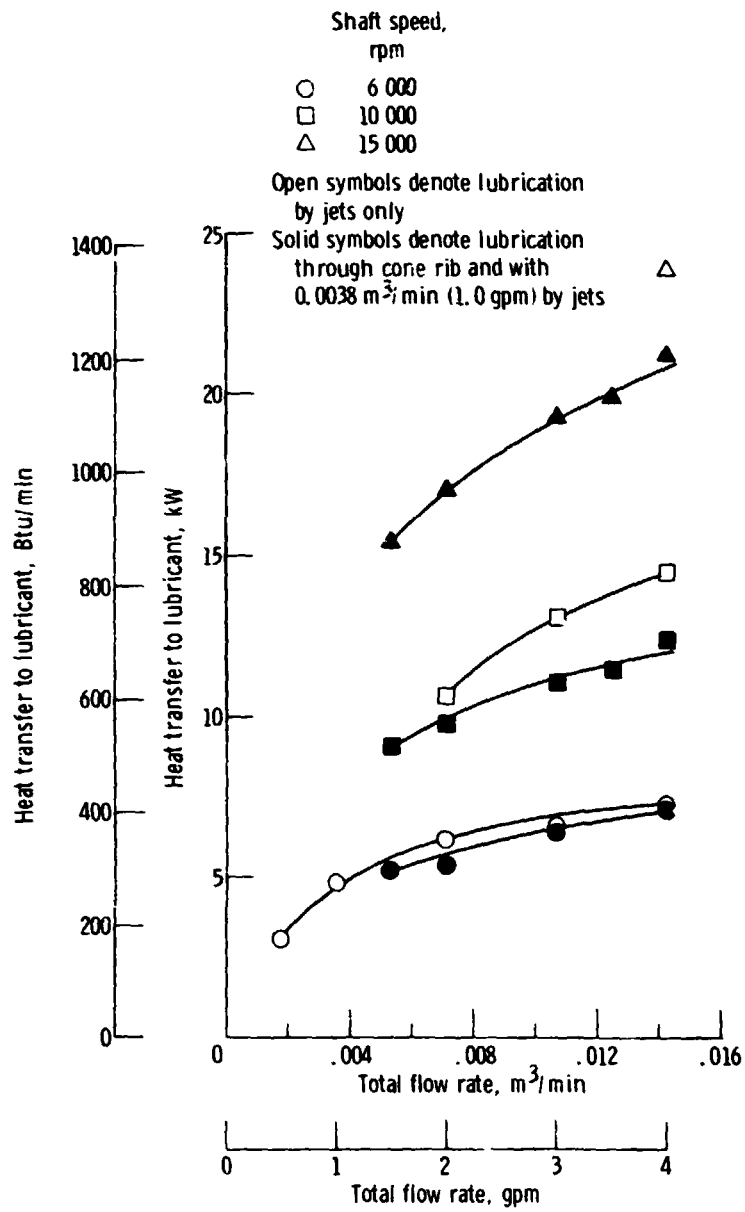

Figure 12. - Heat transferred to lubricant as function of total flow rate. Thrust load, 53 400 N (12 000 lb); radial load, 26 700 N (6000 lb); oil-in temperature, 350 K (170° F).